



SAR Evaluation Report

in accordance with the requirements of
FCC Report and Order: ET Docket 93-62, and OET Bulletin 65 Supplement C

for

PCS WLL TERMINAL

MODEL: DTT1900

FCC ID: PUNDTT-1900

SEPTEMBER 12, 2001

REPORT NO: 01I0934-2

Prepared for
DOWTELECOM INC.
4TH Floor, Woosong Bldg. 361-10, Yatap-Dong
Bundang-Gu, Seongnam-Si,
Gyunggi-Do, Korea

Prepared by
COMPLIANCE CERTIFICATION SERVICES
561F MONTEREY ROAD,
MORGAN HILL, CA 95037, USA
TEL: (408) 463-0885

NVLAP[®]
LAB CODE:200065-0

CERTIFICATE OF COMPLIANCE (SAR EVALUATION)

Dates of Tests: **SEPTEMBER 10, 2001**
Report No: **01U0934-2**

APPLICANT:	DOWTELECOM INC. 4 TH Floor, Woosong Bldg. 361-10, Yatap-Dong Bundang-Gu, Seongnam-Si, Gyunggi-Do, Korea
TRADE NAME:	DOWTELECOM INC.
MODEL:	DTT1900
SERIAL NUMBER:	N/A (PRE-PRODUCTION)
FCC ID:	PUNDDT-1900
CATEGORY:	MOBILE DEVICE

Test Sample is a:	Pre-Production Unit
Tx Frequency:	1850MHz to 1910MHz
Rx Frequency:	1930MHz to 1990MHz
Max. RF Output Power:	25dBm (0.316 Watt) (Conducted)
RF Exposure Categories:	General Population/Uncontrolled
Application Type:	Certification
FCC Classification:	Licensed Base Station for Part 24 (E)
FCC Rule Part(s):	§ 2.1093; ET Docket 93.62

This wireless portable device has been shown to be capable of compliance for localized specific absorption rate (SAR) for uncontrolled environment/general population exposure limits specified in ANSI/IEEE Std. C95.1-1992 and had been tested in accordance with the measurement procedures specified in FCC OET 65 Supplement C (released on 6/29/2001 see Test Report).

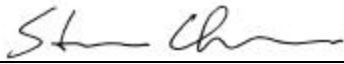

I attest to the accuracy of data. All measurements reported herein were performed by me or were made under my supervision and are correct to the best of my knowledge and belief. I assume full responsibility for the completeness of these measurements and vouch for the qualifications of all persons taking them.

Steve Cheng
EMC Engineering Manager

NVLAP accreditation does not constitute any product endorsement by NVLAP or any agency of the United States Government. CCS certifies that no party to this application has been denied the FCC benefits pursuant to Section 5301 of the Anti-Drug Abuse Act of 1988, 21 U.S.C. 853(a).

TABLE OF CONTENT

1. EUT DESCRIPTION	4
2. REQUIREMENTS FOR COMPLIANCE TESTING DEFINED BY THE FCC.....	5
3. DOSIMETRIC ASSESSMENT SETUP	6
3.1. MEASUREMENT SYSTEM DIAGRAM	7
3.2. SYSTEM COMPONENTS.....	8
3.3. EUT ARRANGEMENT.....	12
4. EUT TUNE-UP PROCEDURE.....	14
5. EVALUATION PROCEDURE.....	15
5.1. SIMULATED TISSUE LIQ UID PARAMETER CONFIRMATION.....	15
5.2. SYSTEM ACCURACY VERIFICATION.....	15
5.3. SAR EVALUATION PROCEDURE	17
5.4. EXPOSURE LIMIT	18
6. RESULTS.....	19
7. REFERENCES	24
8. APPENDIX.....	25
8.1. EUT PHOTOS.....	25
8.2. EQUIPMENTS LIST & CALIBRATION INFO.....	27
8.3. IEEE SCC-34/SC-2 P1528 RECOMMENDED TISSUE DIELECTRIC PARAMET ERS.....	28
8.4. EQUIPMENTS CALIBRATON CERTIFICATE.....	29

1. EUT DESCRIPTION

APPLICANT:	DOWTELECOM INC. 4TH Floor, Woosong Bldg. 361-10, Yatap-Dong Bundang-Gu, Seongnam-Si, Gyeonggi-Do, Korea		
TRADE NAME:	DOWTELECOM INC.	MODEL:	DTT1900
SERIAL NUMBER:	N/A (PRE-PRODUCTION)		
FCC ID:	PUNDDTT-1900		
CATEGORY:	MOBILE DEVICE		

Test Sample is a: Pre-production Unit
EUT Type: CDMA Wireless Local Loop (WLL) Terminal
Trade Name: DOWTELECOM INC.
Model(s): DTT1900
FCC IDENTIFIER: PUNDDTT-1900
S/N: N/A (Pre-Production)
Tx Frequency: 1850MHz to 1910MHz
Application Type: Certification
FCC Classification: Licensed Base Station for Part 24 (E)
FCC Rule Part(s): § 2.1093; ET Docket 93.62
Modulation(s): CDMA
Max. RF Output Power: 25dBm (0.316 Watt) (Conducted)
Antenna Type: TNC-Male omni-directional dipole
Antenna Dimensions: 172mm x 14mm (connector diameter) – 5mm (tip)
Dates of Tests: September 10, 2001
Report Project No.: 0110934-2



¹ Specific Absorption Rate (SAR) is a measure of the rate of energy absorption due to exposure to an RF transmitting source (wireless portable device).

² IEEE/ANSI Std. C95.1-1992 limits are used to determine compliance with FCC ET Docket 93-62.

2. REQUIREMENTS FOR COMPLIANCE TESTING DEFINED BY THE FCC

The US Federal Communications Commission has released the report and order "Guidelines for Evaluating the Environmental Effects of RF Radiation", ET Docket No. 93-62 in August 1996 [1]. The order requires routine SAR evaluation prior to equipment authorization of portable transmitter devices, including portable telephones. For consumer products, the applicable limit is 1.6 mW/g as recommended by the ANSI/IEEE standard C95.1-1992 [6] for an uncontrolled environment (Paragraph 65). According to the Supplement C of OET Bulletin 65 "Evaluating Compliance with FCC Guide-lines for Human Exposure to Radio frequency Electromagnetic Fields", released on Jun 29, 2001 by the FCC, the device should be evaluated at maximum output power (radiated from the antenna) under "worst-case" conditions for normal or intended use, incorporating normal antenna operating positions, device peak performance frequencies and positions for maximum RF energy coupling.

3. DOSIMETRIC ASSESSMENT SETUP

These measurements were performed with the automated near-field scanning system DASY3 from Schmid & Partner Engineering AG (SPEAG). The system is based on a high precision robot (working range greater than 0.9 m) which positions the probes with a positional repeatability of better than ± 0.02 mm. Special E- and H-field probes have been developed for measurements close to material discontinuity, the sensors of which are directly loaded with a Schottky diode and connected via highly resistive lines to the data acquisition unit. The system is described in detail in [3].

The SAR measurements were conducted with the dosimetric probe ET3DV6 SN: 1577 (manufactured by SPEAG), designed in the classical triangular configuration [3] and optimized for dosimetric evaluation. The probe has been calibrated according to the procedure described in [7] with accuracy of better than $\pm 10\%$. The spherical isotropy was evaluated with the procedure described in [8] and found to be better than ± 0.25 dB.

The phantom used was the "Generic Twin Phantom" described in [4]. The ear was simulated as a spacer of 4 mm thickness between the earpiece of the phone and the tissue simulating liquid. The Tissue simulation liquid used for each test is in according with the FCC OET65 supplement C as listed below.

Ingredients (% by weight)	Frequency (MHz)									
	450		835		915		1900		2450	
Tissue Type	Head	Body	Head	Body	Head	Body	Head	Body	Head	Body
Water	38.56	51.16	41.45	52.4	41.05	56.0	54.9	40.4	62.7	73.2
Salt (NaCl)	3.95	1.49	1.45	1.4	1.35	0.76	0.18	0.5	0.5	0.04
Sugar	56.32	46.78	56.0	45.0	56.5	41.76	0.0	58.0	0.0	0.0
HEC	0.98	0.52	1.0	1.0	1.0	1.21	0.0	1.0	0.0	0.0
Bactericide	0.19	0.05	0.1	0.1	0.1	0.27	0.0	0.1	0.0	0.0
Triton X-100	0.0	0.0	0.0	0.0	0.0	0.0	0.0	0.0	36.8	0.0
DGBE	0.0	0.0	0.0	0.0	0.0	0.0	44.92	0.0	0.0	26.7
Dielectric Constant	43.42	58.0	42.54	56.1	42.0	56.8	39.9	54.0	39.8	52.5
Conductivity (S/m)	0.85	0.83	0.91	0.95	1.0	1.07	1.42	1.45	1.88	1.78

3.1. MEASUREMENT SYSTEM DIAGRAM

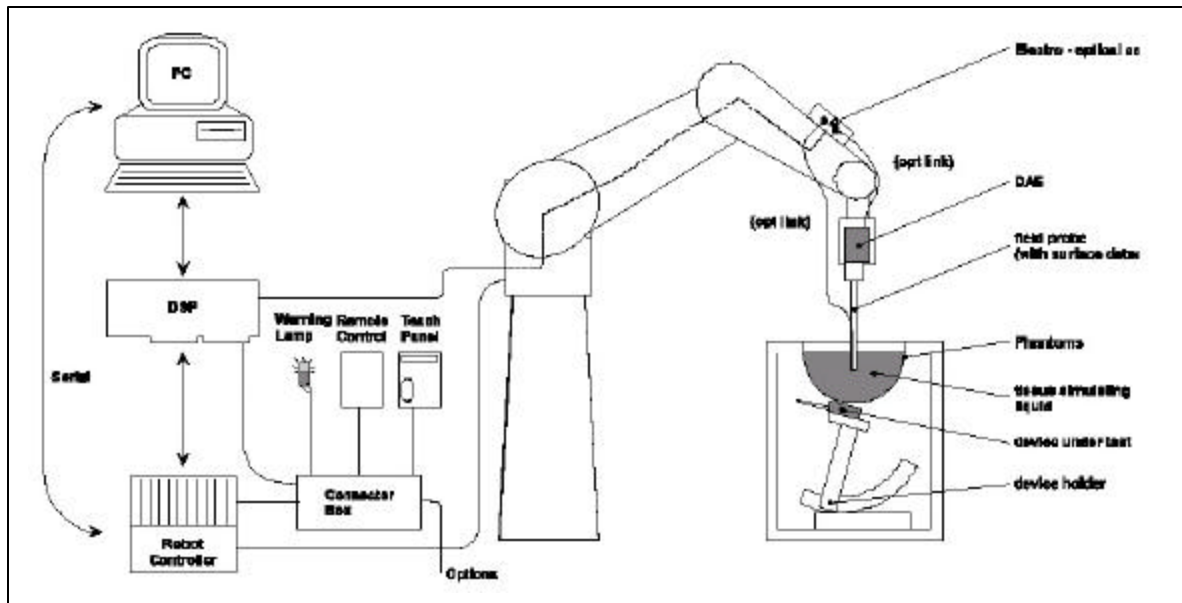

The DASYS3 system for performing compliance tests consist of the following items:

1. A standard high precision 6-axis robot (Stäubli RX family) with controller and software.
2. An arm extension for accommodating the data acquisition electronics (DAE).
3. A dosimetric probe, i.e., an isotropic E-field probe optimized and calibrated for usage in tissue simulating liquid. The probe is equipped with an optical surface detector system.
4. A data acquisition electronic (DAE), which performs the signal amplification, signal multiplexing, AD-conversion, offset measurements, mechanical surface detection, collision detection, etc. The unit is battery powered with standard or rechargeable batteries. The signal is optically transmitted to the EOC.
5. A unit to operate the optical surface detector, which is connected to the EOC. The Electro-optical coupler (EOC) performs the conversion from the optical into a digital electric signal of the DAE. The EOC is connected to the PC plug-in card. The functions of the PC plug-in card based on a DSP is to perform the time critical task such as signal filtering, surveillance of the robot operation fast movement interrupts.
6. A computer operating Windows 95 or larger
7. DASYS3 software
8. Remote control with teaches pendant and additional circuitry for robot safety such as warning lamps, etc.
9. The generic twin phantom enabling testing left-hand and right-hand usage.
10. The device holder for handheld EUT.
11. Tissue simulating liquid mixed according to the given recipes (see Application Note).
12. System validation dipoles to validate the proper functioning of the system.

3.2. SYSTEM COMPONENTS

ET3DV5 Probe Specification

Construction Symmetrical design with triangular core
Built-in optical fiber for surface detection System
Built-in shielding against static charges
Calibration In air from 10 MHz to 2.5 GHz
In brain and muscle simulating tissue at
Frequencies of 450 MHz, 900 MHz and
1.8 GHz (accuracy $\pm 8\%$)
Frequency 10 MHz to > 6 GHz; Linearity: ± 0.2 dB
(30 MHz to 3 GHz)
Directivity ± 0.2 dB in brain tissue (rotation around probe axis)
 ± 0.4 dB in brain tissue (rotation normal probe axis)
Dynamic 5 mW/g to > 100 mW/g;
Range Linearity: ± 0.2 dB
Surface ± 0.2 mm repeatability in air and clear liquids
Detection over diffuse reflecting surfaces.
Dimensions Overall length: 330 mm
Tip length: 16 mm
Body diameter: 12 mm
Tip diameter: 6.8 mm
Distance from probe tip to dipole centers: 2.7 mm
Application General dosimetric up to 3 GHz
Compliance tests of mobile phones
Fast automatic scanning in arbitrary phantoms

The SAR measurements were conducted with the dosimetric probe ET3DV6 designed in the classical triangular configuration and optimized for dosimetric evaluation. The probe is constructed using the thick film technique; with printed resistive lines on ceramic substrates. The probe is equipped with an optical multi-fiber line ending at the front of the probe tip. It is connected to the EOC box on the robot arm and provides an automatic detection of the phantom surface. Half of the fibers are connected to a pulsed infrared transmitter, the other half to a synchronized receiver. As the probe approaches the surface, the reflection from the surface produces a coupling from the transmitting to the receiving fibers. This reflection increases first during the approach, reaches maximum and then decreases. If the probe is flatly touching the surface, the coupling is zero. The distance of the coupling maximum to the surface is independent of the surface reflectivity and largely independent of the surface to probe angle. The DASY3 software reads the reflection during a software approach and looks for the maximum using a 2nd order fitting. The approach is stopped when reaching the maximum.

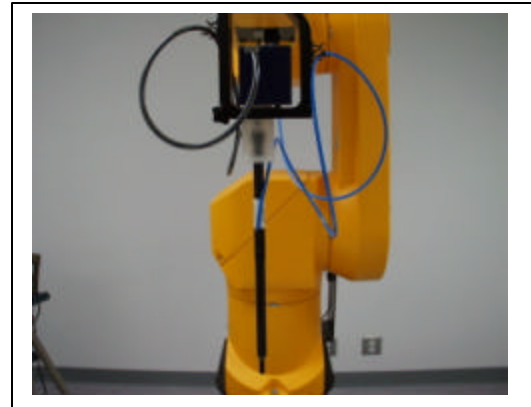

Figure. Photograph of the probe



Figure. Inside view of ET3DV6 E-field Probe

E-Field Probe Calibration Process

Each probe is calibrated according to a dosimetric assessment procedure described in [6] with accuracy better than +/- 10%. The spherical isotropy was evaluated with the procedure described in [7] and found to be better than +/-0.25dB. The sensitivity parameters (NormX, NormY, NormZ), the diode compression parameter (DCP) and the conversion factor (ConvF) of the probe are tested.

The free space E-field from amplified probe outputs is determined in a test chamber. This is performed in a TEM cell for frequencies below 1 GHz, and in a waveguide above 1 GHz for free space. For the free space calibration, the probe is placed in the volumetric center of the cavity and at the proper orientation with the field. The probe is then rotated 360 degrees.

E-field temperature correlation calibration is performed in a flat phantom filled with the appropriate simulated brain tissue. The measured free space E-field in the medium correlates to temperature rise in dielectric medium. For temperature correlation calibration a RF transparent thermistor-based temperature probe is used in conjunction with the E-field probe.

Data Evaluation

The DASY3 software automatically executes the following procedures to calculate the field units from the microvolt readings at the probe connector. The parameters used in the evaluation are stored in the configuration modules of the software:

Probe parameters:	- Sensitivity	Norm _i , a _{i0} , a _{i1} , a _{i2}
	- Conversion factor	ConvF _i
	- Diode compression point	Dcp _i
Device parameters:	- Frequency	f
	- Crest factor	cf
Media parameters:	- Conductivity	σ
	- Density	ρ

These parameters must be set correctly in the software. They can either be found in the component documents or be imported into the software from the configuration files issued for the DASY3 components. In the direct measuring mode of the multi-meter option, the parameters of the actual system setup are used. In the scan visualization and export modes, the parameters stored in the corresponding document files are used.

The first step of the evaluation is a linearization of the filtered input signal to account for the compression characteristics of the detector diode. The compensation depends on the input signal, the diode type and the DC-transmission factor from the diode to the evaluation electronics. If the exciting field is pulsed, the crest factor of the signal must be known to correctly compensate for peak power. The formula for each channel can be given as:

$$V_i = U_i + U_i^2 \cdot \frac{cf}{dcp_i}$$

with	V _i	= compensated signal of channel i	(i = x, y, z)
	U _i	= input signal of channel i	(i = x, y, z)
	cf	= crest factor of exciting field	(DASY parameter)
	dcp _i	= diode compression point	(DASY parameter)

From the compensated input signals the primary field data for each channel can be evaluated:

E-field probes:
$$E_i = \sqrt{\frac{V_i}{\text{Norm}_i \cdot \text{ConvF}}}$$

H-field probes:
$$H_i = \sqrt{V_i} \cdot \frac{a_{i0} + a_{i1}f + a_{i2}f^2}{f}$$

- with V_i = compensated signal of channel i (i = x, y, z)
 Norm_i = sensor sensitivity of channel i (i = x, y, z)
 $\mu\text{V}/(\text{V}/\text{m})^2$ for E-field Probes
 ConvF = sensitivity enhancement in solution
 a_{ij} = sensor sensitivity factors for H-field probes
 f = carrier frequency [GHz]
 E_i = electric field strength of channel i in V/m
 H_i = magnetic field strength of channel i in A/m

The RSS value of the field components gives the total field strength (Hermitian magnitude):

$$E_{\text{tot}} = \sqrt{E_x^2 + E_y^2 + E_z^2}$$

The primary field data are used to calculate the derived field units.

$$\text{SAR} = E_{\text{tot}}^2 \cdot \frac{\sigma}{\rho \cdot 1000}$$

- with SAR = local specific absorption rate in mW/g
 E_{tot} = total field strength in V/m
 σ = conductivity in [mho/m] or [Siemens/m]
 ρ = equivalent tissue density in g/cm^3

Note that the density is normally set to 1 (or 1.06), to account for actual brain density rather than the density of the simulation liquid.

The power flow density is calculated assuming the excitation field as a free space field.

$$P_{\text{pwe}} = \frac{E_{\text{tot}}^2}{3770} \quad \text{or} \quad P_{\text{pwe}} = H_{\text{tot}}^2 \cdot 37.7$$

- with P_{pwe} = equivalent power density of a plane wave in mW/cm^2
 E_{tot} = total electric field strength in V/m
 H_{tot} = total magnetic field strength in A/m

Generic Twin Phantom

The Generic Twin Phantom is constructed of a fiberglass shell integrated in a wooden table. The shape of the shell is based on data from an anatomical study designed to determine the maximum exposure in at least 90% of all users [9][10]. It enables the dosimetric evaluation of left and right hand phone usage as well as body mounted usage at the flat phantom region. A cover prevents the evaporation of the liquid. Reference markings on the Phantom allows the complete setup of all predefined phantom positions and measurement grids by manually teaching three points in the robot. See Figure 8.

Shell Thickness 2 ± 0.1 mm

Filling Volume Approx. 20 liters

Dimensions 810 x 1000 x 500 mm (H x L x W)



Fig. Generic Twin Phantom

Device Holder for Transmitters

In combination with the Generic Twin Phantom V3.0, the Mounting Device enables the rotation of the mounted transmitter in spherical coordinates whereby the rotation points is the ear opening. The devices can be easily, accurately, and repeatedly positioned according to the FCC and CENELEC specifications. The device holder can be locked at different phantom locations (left head, right head, flat phantom).

* Note: A simulating human hand is not used due to the complex anatomical and geometrical structure of the hand that may produced infinite number of configurations [10]. To produce the worst-case condition (the hand absorbs antenna output power), the hand is omitted during the tests.

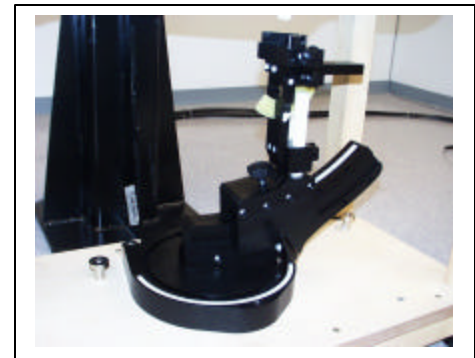

Fig. Device Holder

3.3. EUT ARRANGEMENT

Desk Top Configuration

The EUT is a desktop WLL station, and generally is allocated more than 20 cm away from the user. But in considering the possibility that when it was sited on the desk corner there is a good chance that the people walk around or stand in front of the desk could occasionally expose to the near field radiation. For this reason a pre-determined separation distance of 2.8 cm is set to evaluate the SAR.



Figure. Body Holster Configuration

Measurement Uncertainty

The uncertainty budget has been determined for the DASY3 measurement system according to the NIS81 [13] and the NIST1297 [14] documents and is given in the following Table.

Uncertainty Description	Error	Distrib.	Weight	Std. Dev.	Offset
Probe Uncertainty					
Axial isotropy	± 0.2 dB	U-shape	0.5	±2.4 %	
Spherical isotropy	±0.4 dB	U-shape	0.5	±4.8 %	
Isotropy from gradient	±0.5 dB	U-shape	0		
Spatial resolution	±0.5 %	Normal	1	±0.5 %	
Linearity error	±0.2 dB	Rectangle	1	±2.7 %	
Calibration error	±3.3 %	Normal	1	± 3.3 %	
SAR Evaluation Uncertainty					
Data acquisition error	±1%	Rectangle	1	±0.6 %	
ELF and RF disturbances	±0.25 %	Normal	1	±0.25 %	
Conductivity assessment	±10 %	Rectangle	1	± 5.8 %	
Spatial Peak SAR Evaluation Uncertainty					
Extrapol boundary effect	±3%	Normal	1	±3%	± 5%
Probe positioning error	±0.1 mm	Normal	1	± 1%	
Integrat. and cube orient	±3%	Normal	1	±3%	
Cube shape inaccuracies	±2%	Rectangle	1	±1.2 %	
Device positioning	±6%	Normal	1	± 6%	
Combined Uncertainties			1	±11.7 %	± 5%
Extended uncertainty (K = 2)				± 23.5 %.	

4. EUT TUNE-UP PROCEDURE

The following procedures had been used to prepare the EUT for the SAR test.

Confidential, please refer to the manual tune up procedure.

5. EVALUATION PROCEDURE

5.1. SIMULATED TISSUE LIQUID PARAMETER CONFIRMATION

The dielectric parameters were checked prior to assessment using the HP85070A dielectric probe kit. The dielectric parameters measured are reported in each correspondent section:

5.2. SYSTEM ACCURACY VERIFICATION

Prior to the assessment, the system validation kit was used to test whether the system was operating within its specifications of $\pm 10\%$. The validation results are tabulated below. And also the corresponding SAR plot is attached as well in the SAR plots files.

IEEE P1528 recommended reference value

Frequency (MHz)	1 g SAR	10 g SAR	local SAR at surface (above feedpoint)	local SAR at surface ($v=2\text{cm}$ offset from feedpoint)
300	3.0	2.0	4.4	2.1
450	4.9	3.3	7.2	3.2
835	9.5	6.2	14.1	4.9
900	10.8	6.9	16.4	5.4
1450	29.0	16.0	50.2	6.5
1800	38.1	19.8	69.5	6.8
1900	39.7	20.5	72.1	6.6
2000	41.1	21.1	74.6	6.5
2450	52.4	24.0	104.2	7.7
3000	63.8	25.7	140.2	9.5

System validation result

Simulant	Freq [MHz]	Parameters	Liquid Temp [°C]	Target Value	Measured Value	Deviation [%]	Limit [%]
Muscle	1800	ϵ	22.1	53.3	53.5	0.3752	± 5
		σ	22.1	1.52	1.5	-1.3168	± 5
		1 g SAR	22.1	38.1	38.0	-0.2625	± 10

9/10/01

Dipole 1800 MHz

Generic Twin Phantom; Flat Section; Position: (90°,90°); Frequency: 1800 MHz
Probe: ET3DV6_M - SN1577; ConvF(5.40,5.40,5.40); Crest factor: 1.0; Muscle 1800 MHz: $\sigma = 1.50$ mho/m $\epsilon_r = 53.5$ $\rho = 1.00$ g/cm³
Cube 5x5x7: SAR (1g): 9.50 mW/g, SAR (10g): 5.08 mW/g, (Worst-case extrapolation)
Coarse: Dx = 15.0, Dy = 15.0, Dz = 10.0
Powerdrift: 0.01 dB

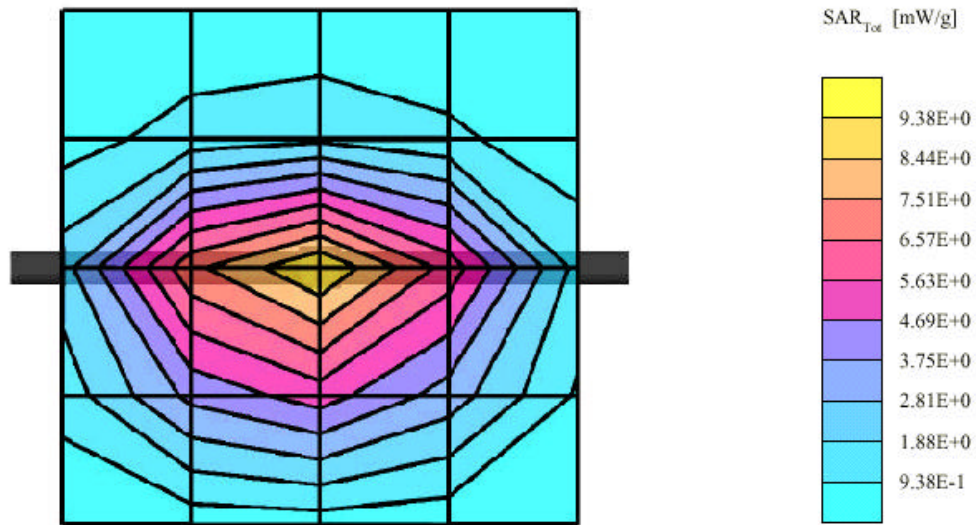

Note: Output Power = 250mW

5.3. SAR EVALUATION PROCEDURE

The evaluation was performed with the following procedure:

Step 1: Measurement of the SAR value at a fixed location above the ear point or central position was used as a reference value for assessing the power drop.

Step 2: The SAR distribution at the exposed side of the head was measured at a distance of 3.9 mm from the inner surface of the shell. The area covered the entire dimension of the head or EUT and the horizontal grid spacing was 20 mm x 20 mm. Based on these data, the area of the maximum absorption was determined by spline interpolation.

Step 3: Around this point, a volume of 32 mm x 32 mm x 34 mm was assessed by measuring 5 x 5 x 7 points. On the basis of this data set, the spatial peak SAR value was evaluated under the following procedure:

1. The data at the surface were extrapolated, since the center of the dipoles is 2.7 mm away from the tip of the probe and the distance between the surface and the lowest measuring point is 1.2 mm. The extrapolation was based on a least square algorithm [11]. A polynomial of the fourth order was calculated through the points in z-axes. This polynomial was then used to evaluate the points between the surface and the probe tip.
2. The maximum interpolated value was searched with a straightforward algorithm. Around this maximum the SAR values averaged over the spatial volumes (1 g or 10 g) were computed by the 3D-Spline interpolation algorithm. The 3D-Spline is composed of three one-dimensional splines with the "Not a knot"-condition (in x, y and z-directions) [11], [12]. The volume was integrated with the trapezoidal-algorithm. One thousand points (10 x 10 x 10) were interpolated to calculate the average.
3. All neighboring volumes were evaluated until no neighboring volume with a higher average value was found.

Step 4: Re-measurement of the SAR value at the same location as in Step 1. If the value changed by more than 5%, the evaluation was repeated.

5.4. EXPOSURE LIMIT

(A) Limits for Occupational/Controlled Exposure (W/kg)

Whole-Body	Partial-Body	Hands, Wrists, Feet and Ankles
0.4	8.0	20.0

(B) Limits for General Population/Uncontrolled Exposure (W/kg)

Whole-Body	Partial-Body	Hands, Wrists, Feet and Ankles
0.08	1.6	4.0

NOTE 1: **Whole-Body SAR** is averaged over the entire body, **partial-body SAR** is averaged over any 1 gram of tissue defined as a tissue volume in the shape of a cube. **SAR for hands, wrists, feet and ankles** is averaged over any 10 grams of tissue defined as a tissue volume in the shape of a cube.

Population/Uncontrolled Environments: are defined as locations where there is the exposure of individuals who have no knowledge or control of their exposure.

Occupational/Controlled Environments: are defined as locations where there is exposure that may be incurred by people who are aware of the potential for exposure, (i.e. as a result of employment or occupation).

NOTE:
POPULATION/UNCONTROLLED ENVIRONMENTS
PARTIAL BODY LIMIT
1.6 mW/g
APPLIED TO THIS PRODUCT

6. RESULTS

This page summarizes the results of the performed dosimetric evaluation. The plots with the corresponding SAR distributions, which reveal information about the location of the maximum SAR with respect to the device could be found in the following pages.

SAR TEST DATA SUMMARY

Ambient TEMPERATURE (°C): 21.1

Relative HUMIDITY (%): 62.8

Summary of worst case SAR reading at 28mm separated distance:

Mode	Position	Ch	Frequency [MHz]	Conducted Power [dBm]	Worst case SAR, averaged over 1g [mW/g]				
					Set-up condition (applicable checked)			Measure d At Distance (28mm)	Limit
					External Di-Pole Antenna	Cheek	Tilted		
PCS	Body	L	1851.25	25	X			1.23	1.6

Measurement Results (1900MHz PCS Body SAR)

Liquid measurement date: 9/10/2001

Simulant	Freq [MHz]	Parameters	Liquid Temp [°C]	Target Value	Measured Value	Deviation [%]	Limit [%]
Body	1900	ϵ	22.1	53.3	51.2	3.9399	± 5
		σ	22.1	1.52	1.58	3.9474	± 5

SAR Measurement result at 28mm separated distance:

Mode	Position	Ch	Frequency [MHz]	Conducted Power [dBm]	Worst case SAR, averaged over 1g [mW/g]				
					Set-up condition (applicable checked)			Measure d At Distance (28mm)	Limit
					External Di-Pole Antenna	Cheek	Tilted		
PCS	Body	L	1851.25	25	X			1.23	1.6
PCS	Body	M	1880	25	X			0.624	1.6
PCS	Body	H	1908.75	25	X			0.931	1.6

Formal Test Plots:

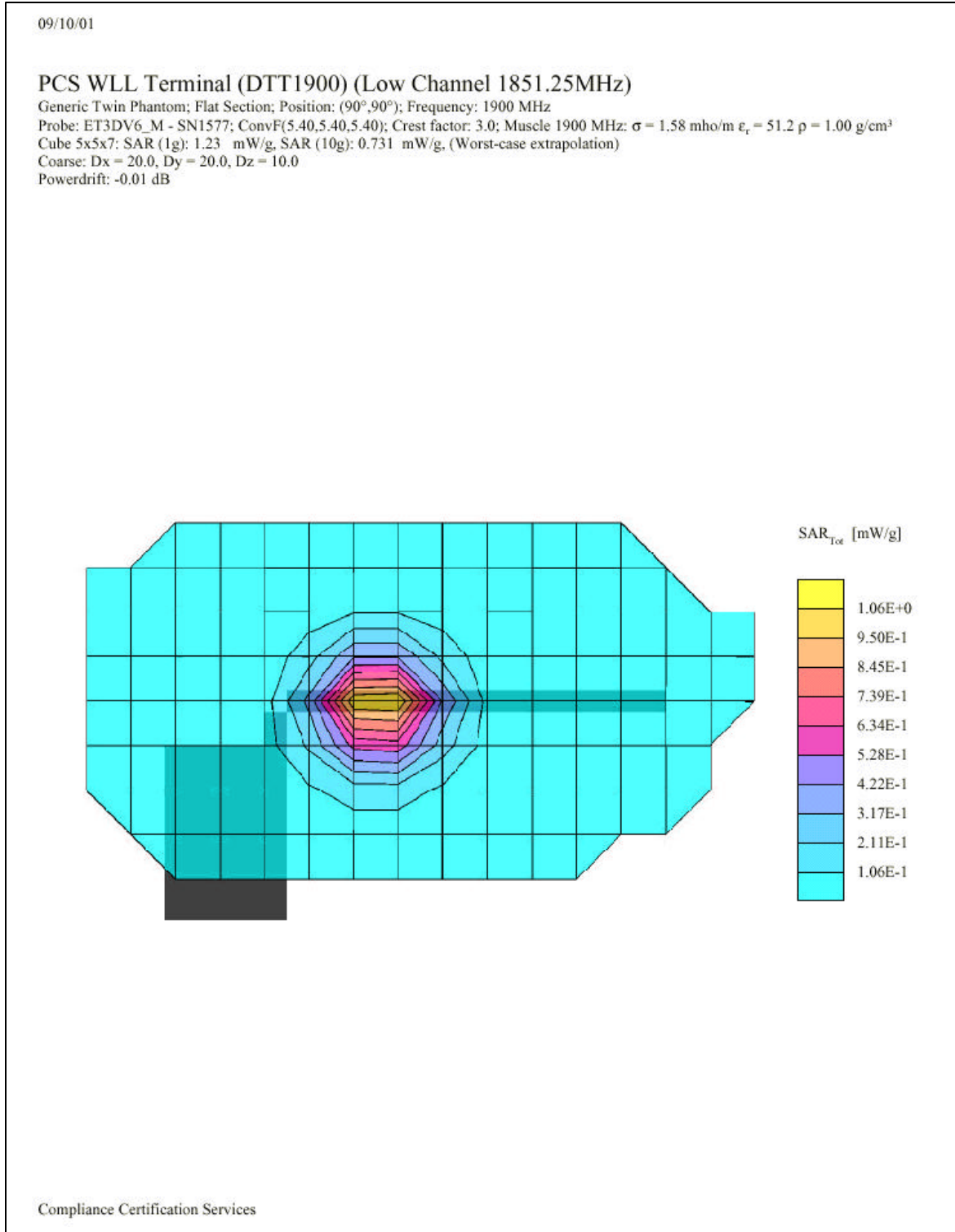

09/10/01

PCS WLL Terminal (DTT1900) (Mid Channel 1880MHz)

Generic Twin Phantom; Flat Section; Position: (90°,90°); Frequency: 1900 MHz

Probe: ET3DV6_M - SN1577; ConvF(5.40,5.40,5.40); Crest factor: 3.0; Muscle 1900 MHz: $\sigma = 1.58 \text{ mho/m}$ $\epsilon_r = 51.2$ $\rho = 1.00 \text{ g/cm}^3$

Cube 5x5x7: SAR (1g): 0.624 mW/g, SAR (10g): 0.372 mW/g. (Worst-case extrapolation)

Coarse: Dx = 20.0, Dy = 20.0, Dz = 10.0

Powerdrift: -0.01 dB

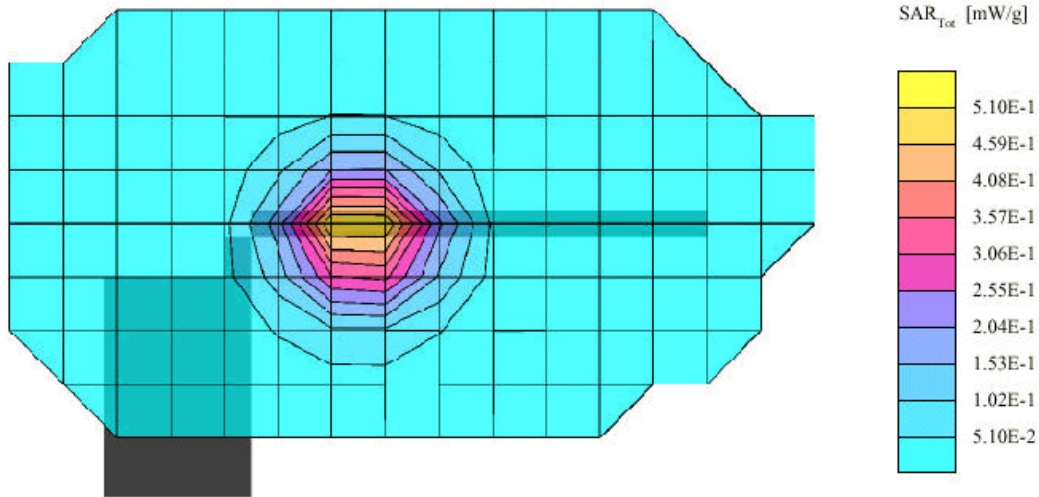

Compliance Certification Services

09/10/01

PCS WLL Terminal (DTT1900) (High Channel 1908.75MHz)

Generic Twin Phantom; Flat Section; Position: (90°,90°); Frequency: 1900 MHz
Probe: ET3DV6_M - SN1577; ConvF(5.40,5.40,5.40); Crest factor: 3.0; Muscle 1900 MHz: $\sigma = 1.58 \text{ mho/m}$ $\epsilon_r = 51.2$ $\rho = 1.00 \text{ g/cm}^3$
Cube 5x5x7: SAR (1g): 0.931 mW/g, SAR (10g): 0.551 mW/g, (Worst-case extrapolation)
Coarse: Dx = 20.0, Dy = 20.0, Dz = 10.0
Powerdrift: -0.06 dB

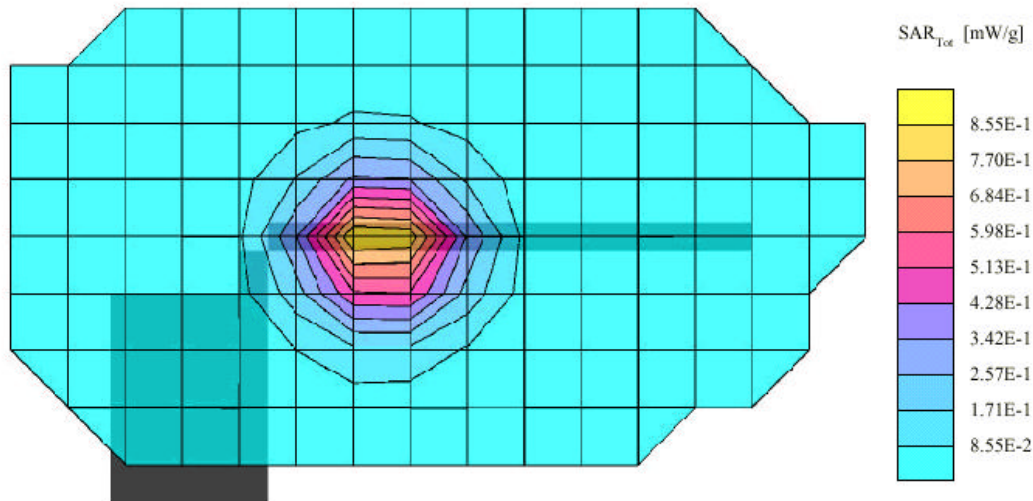

Compliance Certification Services

7. REFERENCES

- [1] Federal Communications Commission, "Report and order: Guidelines for evaluating the environmental effects of radio frequency radiation", Tech. Rep. FCC 96-326, FCC, Washington, D.C. 20554, 1996.
- [2] David L. Means Kwok Chan, Robert F. Cleveland, "Evaluating compliance with FCC guidelines for human exposure to radio frequency electromagnetic fields", Tech. Rep., Federal Communication Commission, Office of Engineering & Technology, Washington, DC, 1997.
- [3] Thomas Schmid, Oliver Egger, and Niels Kuster, "Automated E-field scanning system for dosimetric assessments", IEEE Transactions on Microwave Theory and Techniques, vol. 44, pp. 105-113, Jan. 1996.
- [4] Niels Kuster, Ralph Kastle, and Thomas Schmid, "Dosimetric evaluation of mobile communications equipment with known precision", IEICE Transactions on Communications, vol. E80-B, no. 5, pp. 645-652, May 1997.
- [5] CENELEC, "Considerations for evaluating of human exposure to electromagnetic fields (EMFs) from mobile telecommunication equipment (MTE) in the frequency range 30MHz - 6GHz", Tech. Rep., CENELEC, European Committee for Electro technical Standardization, Brussels, 1997.
- [6] ANSI, ANSI/IEEE C95.1-1992: IEEE Standard for Safety Levels with Respect to Human Exposure to Radio Frequency Electromagnetic Fields, 3 kHz to 300 GHz, The Institute of Electrical and Electronics Engineers, Inc., New York, NY 10017, 1992.
- [7] Katja Pokovic, Thomas Schmid, and Niels Kuster, "Robust setup for precise calibration of E-field probes in tissue simulating liquids at mobile communications frequencies", in ICESOM '97, Dubrovnik, October 15-17, 1997, pp. 120-124.
- [8] Katja Pokovic, Thomas Schmid, and Niels Kuster, "E-field probe with improved isotropy in brain simulating liquids", in Proceedings of the ELMAR, Zadar, Croatia, 23-25 June, 1996, pp. 172-175.
- [9] Volker Hombach, Klaus Meier, Michael Burkhardt, Eberhard Kuhn, and Niels Kuster, "The dependence of EM energy absorption upon human head modeling at 900 MHz", IEEE Transactions on Microwave Theory and Techniques, vol. 44, no. 10, pp. 1865-1873, Oct. 1996.
- [10] Klaus Meier, Ralf Kastle, Volker Hombach, Roger Tay, and Niels Kuster, "The dependence of EM energy absorption upon human head modeling at 1800 MHz", IEEE Transactions on Microwave Theory and Techniques, Oct. 1997, in press.
- [11] W. Gander, Computer mathematics, Birkhaeuser, Basel, 1992.
- [12] W. H. Press, S. A. Teukolsky, W. T. Vetterling, and B. P. Flannery, Numerical Recipes in C, The Art of Scientific Computing, Second Edition, Cambridge University Press, 1992. Dosimetric Evaluation of Sample device, month 1998 9
- [13] NIS81 NAMAS, "The treatment of uncertainty in EMC measurement", Tech. Rep., NAMAS Executive, National Physical Laboratory, Teddington, Middlesex, England, 1994.
- [14] Barry N. Taylor and Christ E. Kuyatt, "Guidelines for evaluating and expressing the uncertainty of NIST measurement results", Tech. Rep., National Institute of Standards and Technology, 1994. Dosimetric Evaluation of Sample device, 1998

8. APPENDIX

8.1. EUT PHOTOS

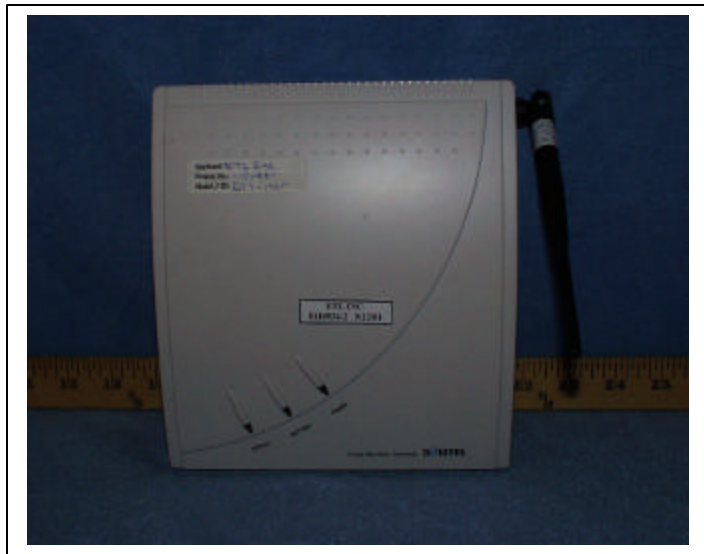



8.2. EQUIPMENTS LIST & CALIBRATION INFO

Type / Model	Cal. Date	S/N:
DASY3 Professional Dosimetric System	N/A	
Robot RX90BL	N/A	F00/5H31A1/A/01
Robot Controller	N/A	D22134001-1
Teach Pendant	N/A	321
Dell Computer Optiplex GX110	N/A	
Pentium III, Windows NT	N/A	
SPEAG EDC3	N/A	
SPEAG DAE3	4/27/01	421
SPEAG E-Field Probe ET3DV6	4/20/01	1577
SPEAG E-Field Probe ET3DV6	4/20/01	1578
SPEAG Dummy Probe	N/A	
SPEAG Generic Twin Phantom	N/A	
SPEAG Light Alignment Sensor	N/A	261
SPEAG Validation Dipole D1800V2	4/19/01	294
SPEAG Validation Dipole D900V2	4/17/01	108
Brain Equivalent Matter (800MHz)	Daily	
Brain Equivalent Matter (1900MHz)	Daily	
Muscle Equivalent Matter (800MHz)	Daily	
Muscle Equivalent Matter (1900MHz)	Daily	
Robot Table	N/A	
Phone Holder	N/A	
Phantom Cover	N/A	
HP Spectrum Analyzer HP8593GM	6/20/01	3009A00791
Microwave Amp. Model: ZHL-42W	N/A	D072701-5
Power Meter HP436A	4/2/01	2709A29209
Power Sensor HP8482A	4/2/01	2349A08568
Signal Generator HP-83732B	3/21/01	US13449049
Network Analyzer HP-8753ES	7/28/01	MY40001647
Dielectric Probe Kit HP85070A	N/A	

8.3. IEEE SCC-34/SC-2 P1528 RECOMMENDED TISSUE DIELECTRIC PARAMETERS

The head tissue dielectric parameters recommended by the IEEE SCC-34/SC-2 in P1528 have been incorporated in the following table. These head parameters are derived from planar layer models simulating the highest expected SAR for the dielectric properties and tissue thickness variations in a human head. Other head and body tissue parameters that have not been specified in P1528 are derived from the tissue dielectric parameters computed from the 4-Cole-Cole equations and extrapolated according to the head parameters specified in P1528.

Target Frequency (MHz)	Head		Body	
	ϵ_r	σ (S/m)	ϵ_r	σ (S/m)
150	52.3	0.76	61.9	0.80
300	45.3	0.87	58.2	0.92
450	43.5	0.87	56.7	0.94
835	41.5	0.90	55.2	0.97
900	41.5	0.97	55.0	1.05
915	41.5	0.98	55.0	1.06
1450	40.5	1.20	54.0	1.30
1610	40.3	1.29	53.8	1.40
1800 – 2000	40.0	1.40	53.3	1.52
2450	39.2	1.80	52.7	1.95
3000	38.5	2.40	52.0	2.73
5800	35.3	5.27	48.2	6.00

(ϵ_r = relative permittivity, σ = conductivity and $\rho = 1000 \text{ kg/m}^3$)

8.4. EQUIPMENTS CALIBRATION CERTIFICATE

Schmid & Partner Engineering AG	
<u>Zeughausstrasse 43, 8004 Zurich, Switzerland, Phone +41 1 245 97 00, Fax +41 1 245 97 79</u>	
Calibration Certificate	
Dosimetric E-Field Probe	
Type:	ET3DV6
Serial Number:	1577
Place of Calibration:	Zurich
Date of Calibration:	Apr. 20, 2001
Calibration Interval:	12 months
<p>Schmid & Partner Engineering AG hereby certifies, that this device has been calibrated on the date indicated above. The calibration was performed in accordance with specifications and procedures of Schmid & Partner Engineering AG.</p> <p>Wherever applicable, the standards used in the calibration process are traceable to international standards. In all other cases the standards of the Laboratory for EMF and Microwave Electronics at the Swiss Federal Institute of Technology (ETH) in Zurich, Switzerland have been applied.</p>	
Calibrated by:	<i>M. Esteban Herrera</i>
Approved by:	<i>J. Garcia</i>

**Schmid & Partner
Engineering AG**

DASY - DOSIMETRIC ASSESSMENT SYSTEM

CALIBRATION REPORT

DATA ACQUISITION ELECTRONICS

MODEL: DAE3 V1

SERIAL NUMBER: 427

This Data Acquisition Unit was calibrated and tested using a FLUKE 702 Process Calibrator. Calibration and verification were performed at an ambient temperature of 23 ± 5 °C and a relative humidity of < 70%.

Measurements were performed using the standard DASY software for converting binary values, offset compensation and noise filtering. Software settings are indicated in the reports.

Results from this calibration relate only to the unit calibrated.

Calibrated by: E. Meyer

Calibration Date: April 27, 2001

DASY Software Version: DASY3 V3.1c