

FCC RF EXPOSURE INFORMATION

Please read this information before use

In August 1996 the Federal Communications Commission (FCC) of the United States with its action in Report and Order FCC 96-326 adopted an updated safety standard for human exposure to radio frequency (RF) electromagnetic energy emitted by FCC regulated transmitters. Those guidelines are consistent with the safety standard previously set by both U.S. and international standards bodies. The design of this phone complies with the FCC guidelines and these international standards.

Use only the supplied or an approved antenna. Unauthorized antennas, modifications, or attachments could impair call quality, damage the phone, or result in violation of FCC regulations.

This wireless local loop terminal has been tested for FCC RF exposure requirements. To comply with FCC RF exposure requirements this device must be operated with a minimum separation distance of 3.0cm (1.2 inches) between the user/nearby persons and the antenna, including hands, wrists, feet, and ankles.

For more information about RF exposure, please visit the FCC website at www.fcc.gov

1. Introduction

Thank you for purchasing this product. Please check whether the product package contains the following items. If there are missing items, please call the service center.

1. Phone

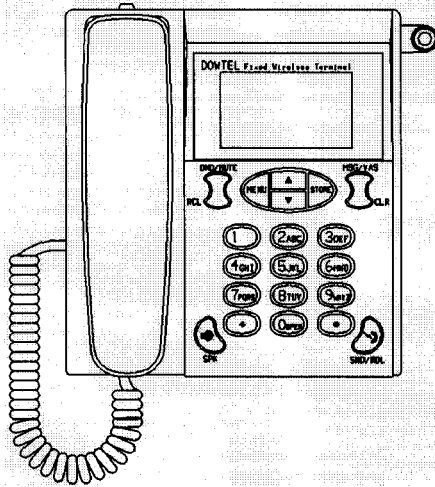

2. Power Supply(SMPS)

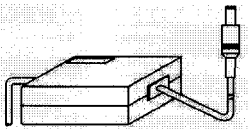

3. Antenna



4. Installation Panel



5. User's Manual

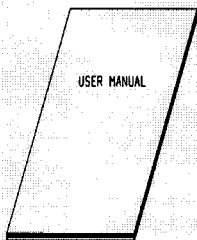

6. Power Cord

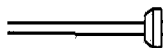

7. Screws

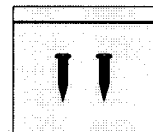

1.1 Installation Procedure

- ① Connect the DC jack to the back panel of phone as shown in the figure below.

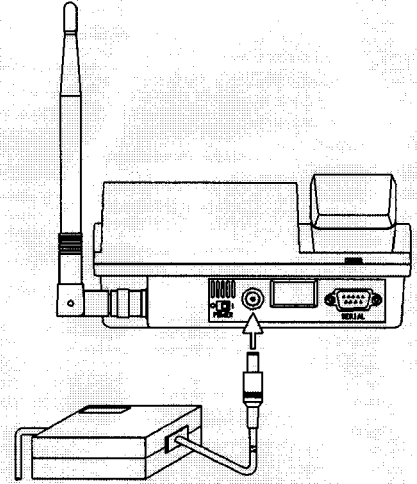
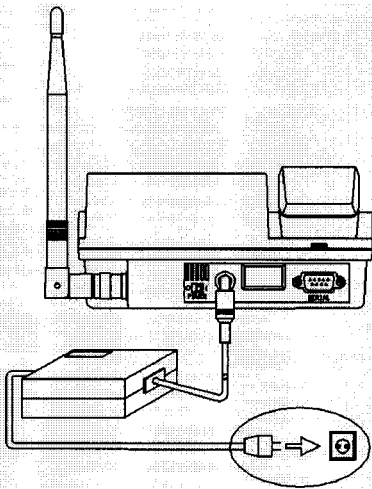

- ② Connect the plug of the SMPS to a power outlet and to SMPS for the phone.

- ③ Turn power on by moving the switch button to the right as shown following figure, and then the phone is initialized with power-up sound.

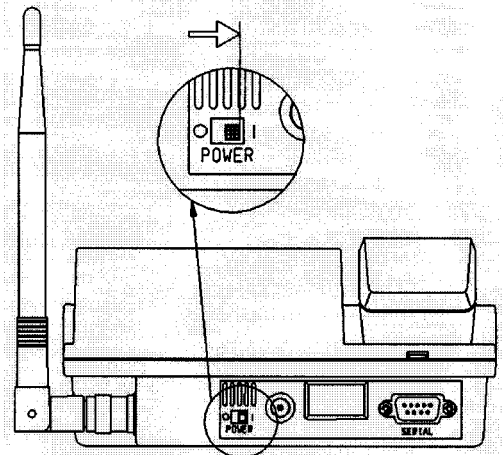

- ④ Adjust the antenna direction until the maximum Antenna power sign is displayed on the LCD screen.
(Each bar indicates the received signal strength. The more bars mean the higher signal strength, the better service condition.)

☞ See 2.1 Power-Up / Power-Down

1.2 Installation of the Wall Bracket

Before finalizing the precise location of the phone, please perform the signal strength test to find the best location after the unit is assembled.

- ① In case of the concrete wall, make 3mm holes with a drill at the marked location and attach the Installation Panel. When install mounting screws, do not screw in all the way. Leave 2mm space between the screw head and the installed panel.

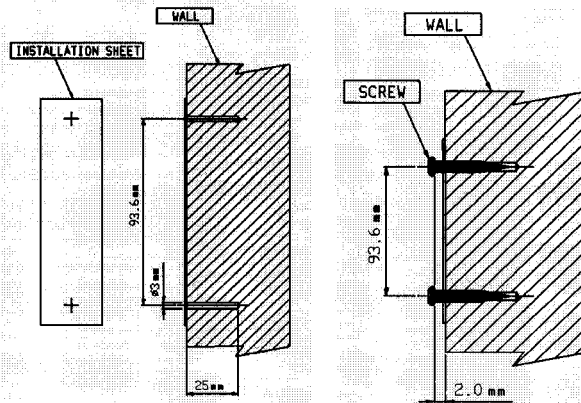

- ② On the bottom of the phone, please find the wall mounting slots(A1 ~A4). Install A1 and A2 onto the top screws. And then push the wall mounting slots A3 and A4 onto the bottom screws so that the phone is finally seated.

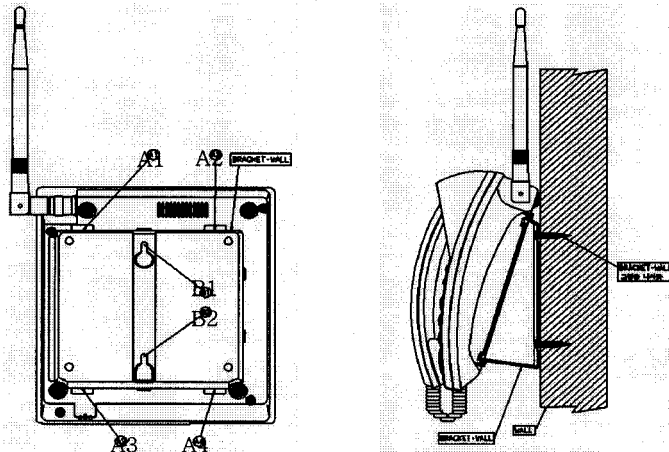

1.3 Panel Overview

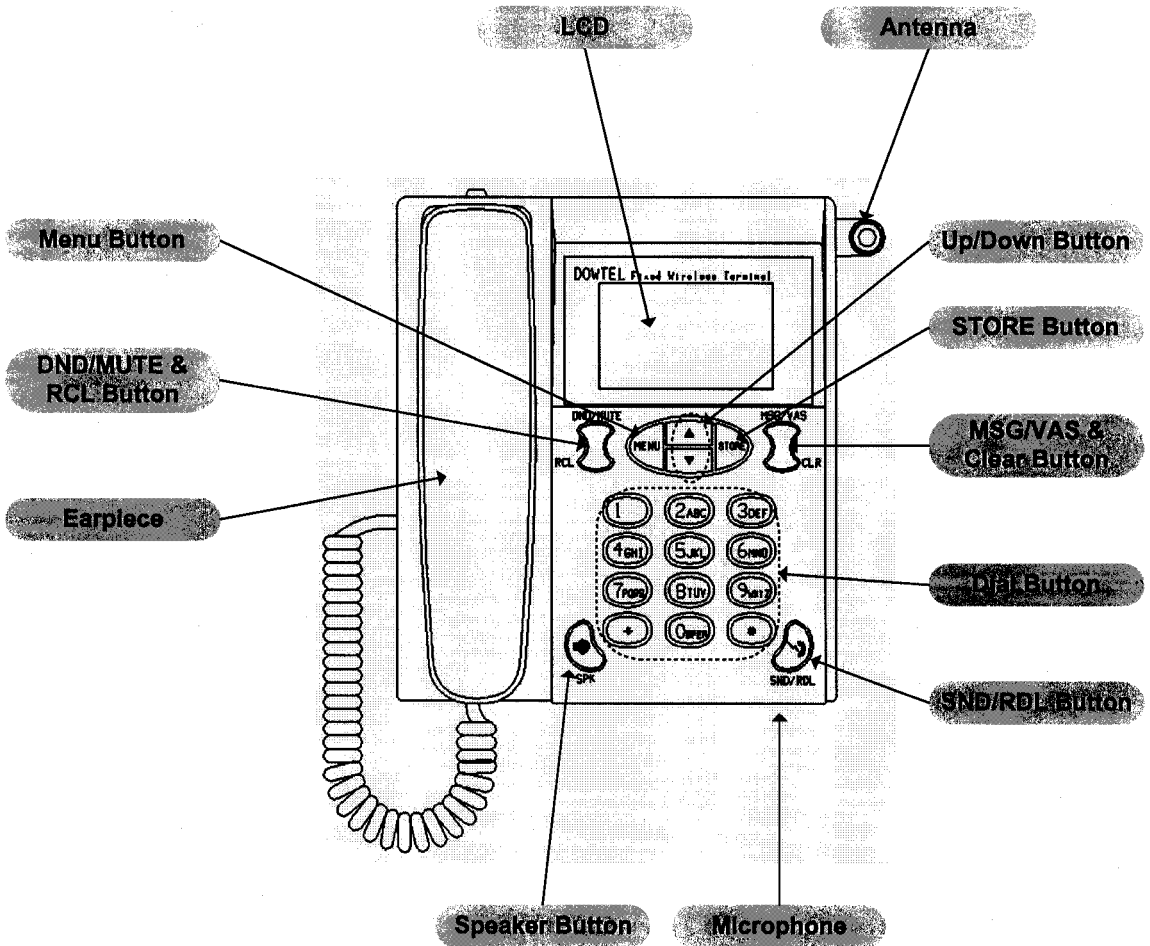

Figure: 1.2 - 1

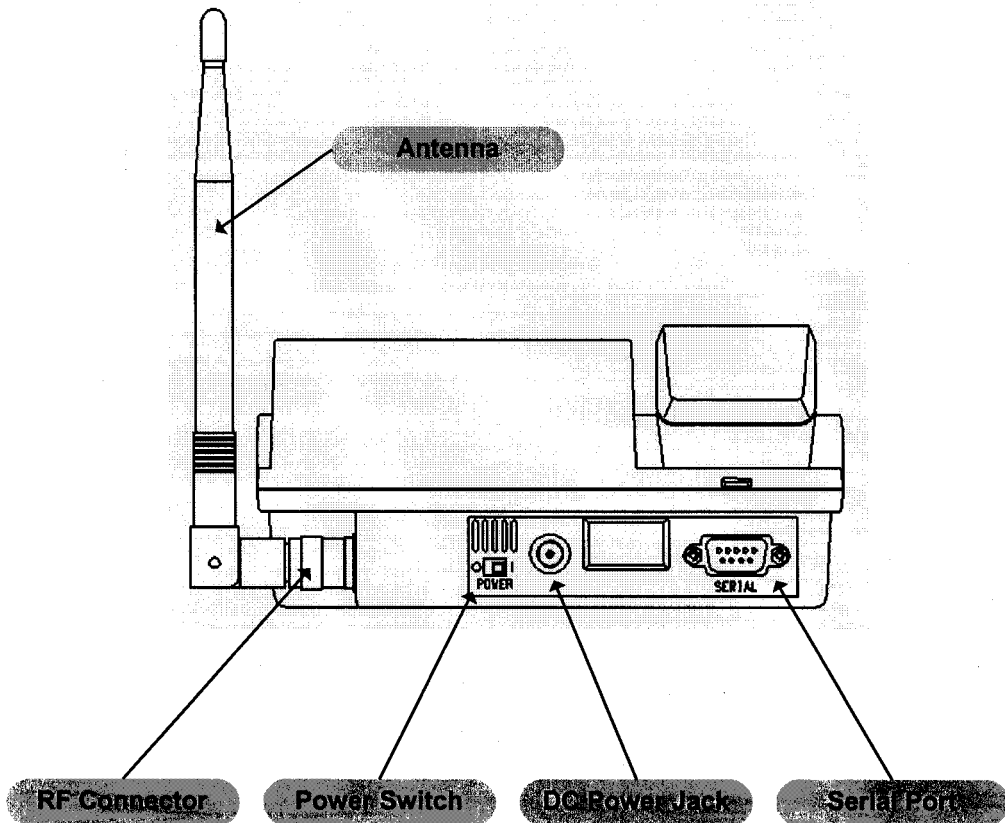

Figure : 1.2 - 2

1.4 Safety Instructions

Basic safety precautions should always be followed to reduce the risk when using this unit.

- **Read and follow all instructions marked on the product.**
- Do not disassemble this unit to reduce the risk of electric shock. When the unit is subsequently used, incorrect reassembly can cause electric shock. When service is required take the unit to an authorized service center.
- Do not hold or contact the antenna while a call.
- Do not overload the wall outlets and the extension cord.
- Do not use this product near the water and never spill any liquid on the unit. This may result in the risk of fire or electric shock.
- Do not place this product on unstable location (cart, stand or table). This may result in the risk of serious damage if this product may fall.
- Do not cover slots and openings on the unit. This product is provided for ventilation and protection against overheating. Do not place this product near the heater or radiator where proper ventilation is not provided.
- This product should be operated from the type of power source marked on the product. If you are not sure of the type of power available, consult with your dealer or local power company.
- Never push objects of any kind into this product, since this may result serious voltage short. It can result in the risk of fire or electric shock.
- During thunderstorms, avoid using this product. There may be a remote risk of an electric shock from lighting.
- Unplug this product from the wall outlets and refer servicing to an authorized service center under the following conditions:
 - When the power supply plug is damaged or frayed.
 - If liquid has been spilled into this product.
 - If this product has been exposed to water or rain.
 - If this product does not work properly when the operating instruction are followed.
 - If this product has been dropped or damaged.
 - If this product exhibits a distinct change in performance.

2. Before Using

2.1 Power-Up / Power-Down

2.1.1 General Power-Up

- ① Manufacturer's logo will be displayed for 1 second when the power is turned on.

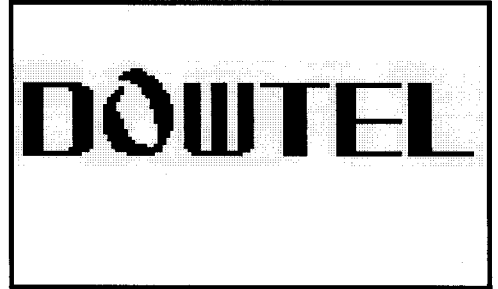

Figure : 2.1.1-1

- ② The screen (figure 2.1.1-2) will be displayed with the power-up sound.

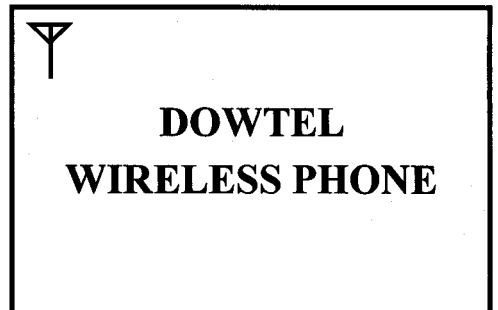

Figure : 2.1.1-2

- ③ If the phone receives the signal from the Service Provider, the screen displays the default date and time set by factory. (figure 2.1.1-3)

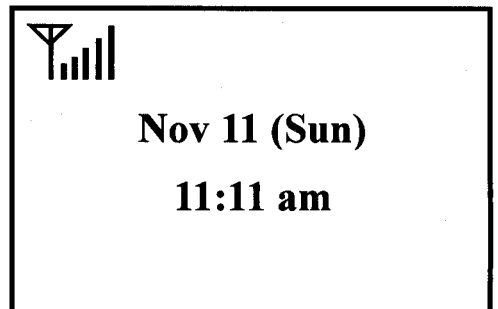

Figure : 2.1.1-3

2.1.2 No Service

If “No Service” message is appeared like the figure 2.1.2, the location where the phone is installed may be the area of which the signal from the Service Provider is not delivered to the phone.

If the number of bar beside the Ant. symbol on the screen in figure 2,1,1-3 is small, it means the received signal strength is weak. < Reference 2.3.1 RSSI Icon>

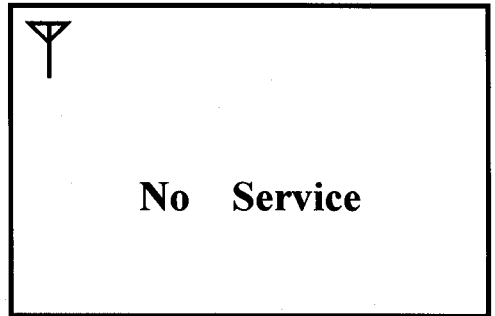

Figure : 2.1.2

In this case, adjust the direction of antenna until the number of bar is displayed as many as possible.

If the condition like figure 2.1.2 is continued or the number of bar is small despite of changing the direction of antenna, please ask the service center.

2.1.3 Registration Required

If “Registration Required” message is appeared like figure 2.1.3, it means this phone cannot be registered to the Service Provider.

In this case, report to the Service Provider immediately.

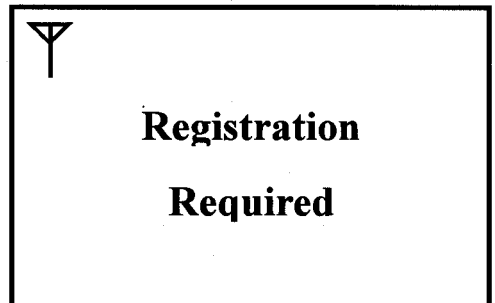

Figure : 2.1.3

2.1.4 Power

Two types power is used in this phone.

- AC power : 100 ~ 240 V
- Internal Battery

If the AC power is suddenly disconnected to the phone by a power failure or any reason, the power source is automatically changed from AC power to internal battery. When the status of power switch of the phone is turned on, the phone normally works as long as you disconnect the AC power.

If you don't want the power entirely, you must turn off the power switch.

2.2 Keypad

As shown in the figure below, there are 12-Dial Button and 10-Function Button in this phone.

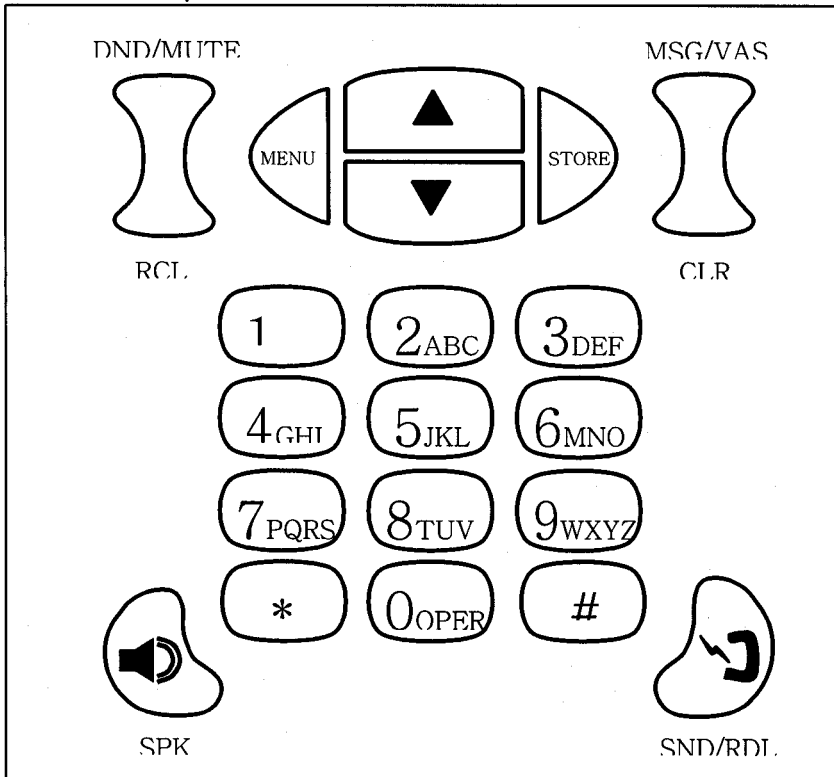
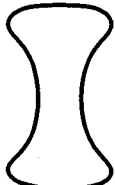

Figure : 2.2.1

2.2.1 DND/MUTE & RCL

DND/MUTE



RCL

DND/MUTE

- Use this button to set on/off the [DND(Do Not Disturb)] function if you don't want to answer the incoming call in idle-state. (Reference 3.8)
- Use this button to set on/off the [MUTE] function if you don't want to send sound to the calling party through the handset or microphone during the conversation.

RCL

Use this button to find the last dialed phone number and to search the stored number in the Phone Book.

<Note>

DND/MUTE & RCL and MSG/VAS & CLR buttons are designed as an one-button as shown in figure 2.2.1. But these buttons separately operate the upper side and bottom side of the button to work their own function.

2.2.2 MENU



Use this button to set the [MENU] mode or return to Idle-state.

2.2.3 UP / DOWN

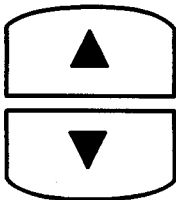

Use this button to set the [MENU] mode, adjust the ringer and voice volume, and store/find the phone number in the Phone Book.

2.2.4 STORE



Use this button to store the Phone Numbers and setting-value under the [MENU] mode.

2.2.5 MSG/VAS & CLR (Clear & Recall)

MSG/VAS

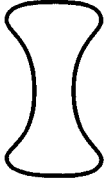

CLR

MSG/VAS

- Use this button if you want to retrieve the text message of SMS(Short Message Service) transmitted and received during the idle-state.
- Use this button to make a call to VMC(Voice Message Center) direct to retrieve the voice mail after picking up the handset or setting the speakerphone on.

CLR

Use this button to erase the number when you dialed incorrectly or when you stored the number in the Phone Book incorrectly.

2.2.6 SPEAKER [SPK]

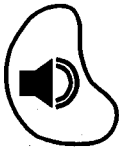

Use this button to make a call or receive a call by using speaker phone.

2.2.7 SEND & REDIAL [SND/RDL]



Use this button to send the dialed number when you make a call and redial the last number dialed.

2.2.8 Dial Button(0~9, *, #)

- Use this button to store the phone number
- There are small alphabets beside the numeric number on the each Dial Button. It is used to store the name related with the phone number when you want to store the phone number.

<Example for use>

If you want to store "DOWTEL3", follow below procedure.

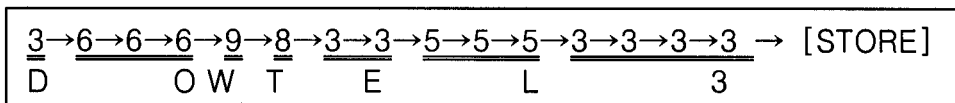

As shown in the example above, the output alphabet character is serially displayed on the LCD screen when you press the button repeatedly.

<Note>

You can store the name with only uppercase character.

2.3 ICON

The various icons are displayed in the first line on the LCD screen to indicate the setting-status and operating-status of the phone.

2.3.1 RSSI Icon



- Indicate the strength of received signal. It is closely related with the quality of service.
- There are 5 bars with different length. It is the best condition if all bars are displayed beside the Antenna symbol.
- When there is only 1-bar on the screen, it means poor service condition. With flashing icon, the phone is capable of only marginally dependable phone operation, means phone can be disconnected.
- When there is no bar on the screen, you cannot make a call because there is no received signal from the service provider in your area.

2.3.2 Connecting Icon



- Indicate the phone is processing a call when you press the [SND/RDL] button to make a call.
- This icon is displayed with the "Connecting..." message.

2.3.3 Off-Hook Icon



- Indicate the Hook Switch Mode of the phone.
- It is displayed when the handset is picked up from the phone.

2.3.4 Speaker Phone Icon



- Indicate the phone is in Speaker Phone Mode.
- It is displayed when you attempt to make a call using the speaker and microphone.

2.3.5 Voice Mute Icon



- Indicate the status that the user's voice, any surrounding sounds, and keypad tone are not transmitted to the calling party.
- When you set this function on during a conversation, No sound will be transmitted.

2.3.6 PC Fax Receiving Mode Icon



- Indicate the status that the phone is set in PC Fax Received Mode to receive the fax using data service.
- "Fax Rcv Mode" message is displayed in the bottom line on the screen with this icon.
- If a call is received, the Fax Utility connected with the phone in the PC is automatically answered and received the fax. And you cannot speak through the handset or speakerphone.
- You can make a call while in this mode.

2.3.7 Modem Receiving Mode Icon



- Indicate the status that the phone is set in Modem Received Mode to transmit/receive the file using data service.
- "Modem Rcv Mode" message is displayed in the bottom line on the screen with this icon.
- If a call is received, the Communication Utility connected with the phone in the PC is automatically answered and received the file. And you cannot speak through the handset or speakerphone.
- You can make a call while in this mode.

2.3.8 Battery Icon



- Indicate the strength of the battery installed inside the phone
- The battery strength is displayed 5-step.
- When the battery strength is weakening, the phone beeps to request the recharge of the battery.

2.3.9 DND (Do Not Disturb) Icon



- Indicate the status that user set DND function on to deny the incoming call when user don't want to answer the incoming call.
- During this icon is flashing, the phone doesn't answer to the incoming call.

2.3.10 Message Icon



- Indicate the status that the phone is received the Text Message and/or Voice Message.
- When the message is received, this icon is displayed on the screen with the indicate-tone.
- You can read the received message and retrieve the voice mail through the Voice Mail Center (VMC) in the system using the [MSG/VAS] button.

2.4 Sound & Tone

2.4.1 Power-up Sound

When you turn on the power of the phone, The phone starts with the beep-sound.

2.4.2 Dial Tone

This sound indicates that the phone is able to connect with the system and you can make or receive a call

2.4.3 Warning Tone

When the phone is unable to connect with the system or the handset is incorrectly placed on the phone, it beeps through the handset or speaker.

2.4.4 Howler Tone

It beeps for 30 seconds through the speaker when same situation is continued even though the warning tone is stopped.

2.4.5 Keypad Tone

When you push the keypad, it beeps through the speaker or handset.

2.4.6 Ring Sound

When a call is being received, it beeps through the speaker.

2.4.7 Alert Beep per 1 min

When you make a call, it beeps every 1minute during the conversation.

2.4.8 Low Battery Warning Tone

When you use the phone using the internal battery, it beeps through the speaker when the battery strength is weak.

2.4.9 SMS/VMS notification tone

It beeps through the speaker when the phone is received the SMS or VMS message.

2.4.10 Error Beep Tone

It beeps when the user push the keypad incorrectly. In this case, the incorrect operating is ignored.

3. Basic Function

3.1 Making Calls

3.1.1 Using the Handset

- ▶ Pick up the handset and dial the phone number you want to make a call.

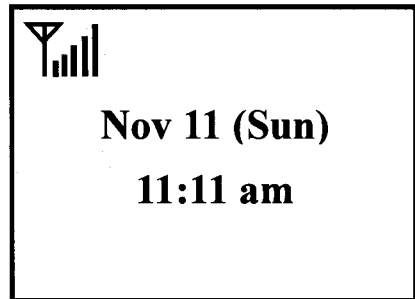

- ▶ Press the [SND/RDL] button

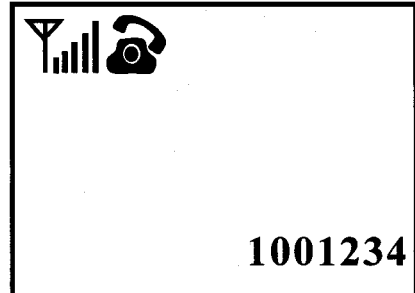

- ▶ The call is connected.

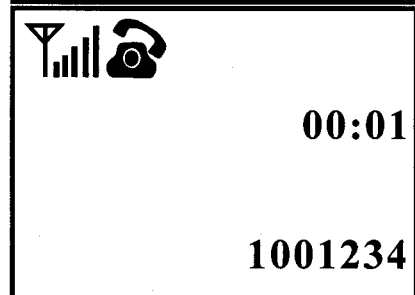
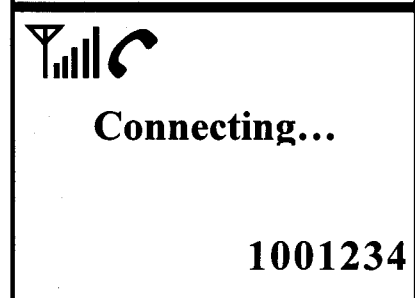

3.1.2 Using the Speaker Phone

- ▶ Press the [SPK] button and dial the phone number you want to make a call.

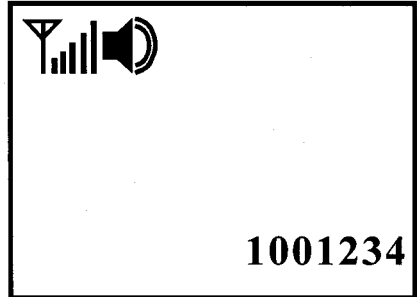

- ▶ Press the [SND/RDL] button.

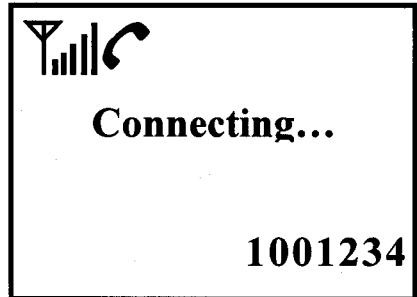

- ▶ The call is connected.

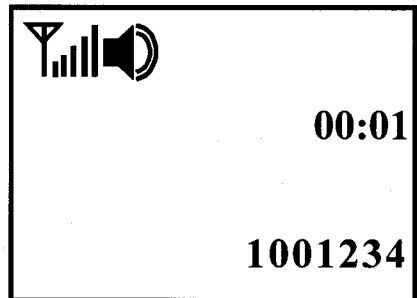

3.1.3 On-Hook Dialing

- ▶ Dial the phone number, and then press the [SND/RDL] button.

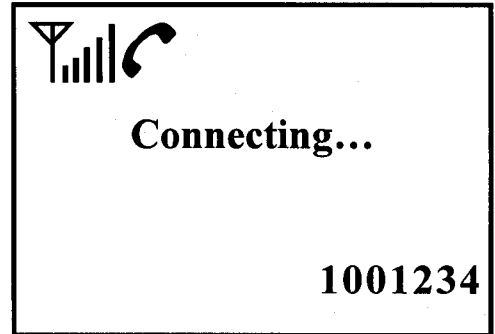

(figure 3.1.3-1)

- ▶ The speaker phone operates automatically, and then the call is connected.

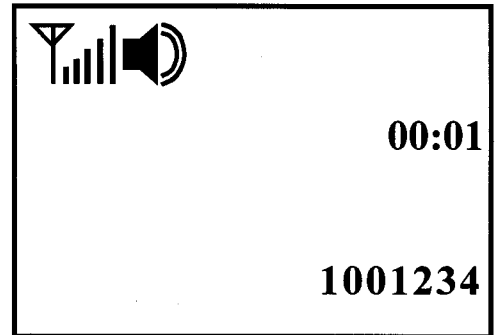

(Figure 3.1.3-2)

3.1.4 Redial the Last Number called

<Method 1>

- ▶ Pick up the handset or press the [SPK] button, and then press [SND/RDL] button.

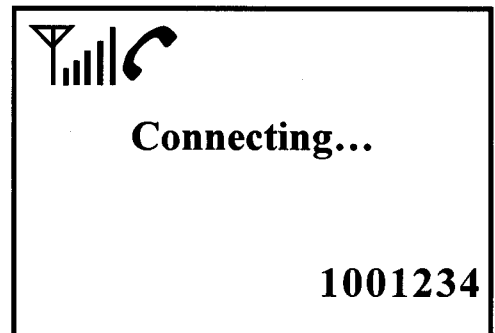

(Figure 3.1.4-1)

- ▶ The last number dialed is connected automatically.

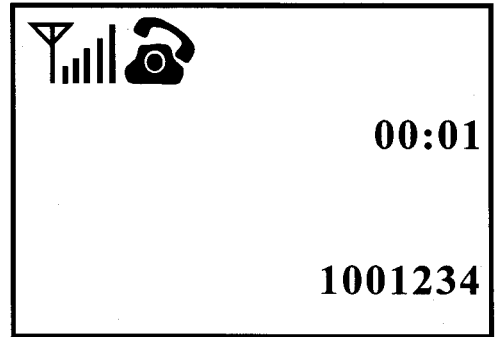

(Figure 3.1.4-2)

<Method 2>

- ▶ Press the [SND/RDL] button, and then the speaker Phone operates automatically.

- ▶ The last number dialed is connected.

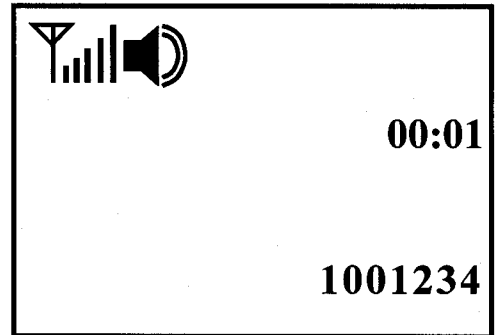

(Figure 3.1.4-3)

3.1.5 Speed Dial

You can store up to 99 phone numbers in this phone using 2-digit addresses (01~99). The stored numbers in the Phone Book allow you to make a call simply by just press these addresses.

And you can search and edit the number in the Phone Book. The method of store/search/edit of the phone number is explained next chapter.

3.1.5.1 One-Touch Dialing

This function allows you to simply make a call just pressing the memory station number ([0] ~ [9]).

<Method 1>

- ▶ Pick up the handset or press the [SPK] button.
- ▶ Press the memory station number stored in the address [1] ~ [9] for over 2 seconds then the stored number dialed, or press the memory station number shortly, and then press the [SND/RDL] button.

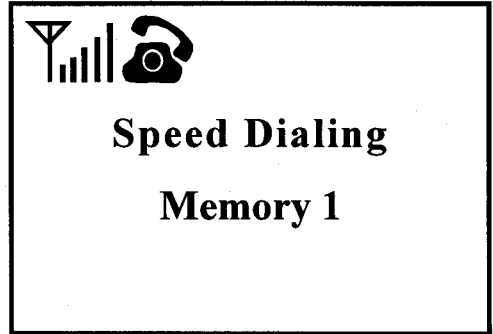

(Figure 3.1.5.1-1)

(Example)

When you want to make a call to the number stored in address [1], press the [SND/RDL] button after press [1] button shortly or press [1] button for over 2 seconds.

- ▶ The number in the Phone Book is connected.

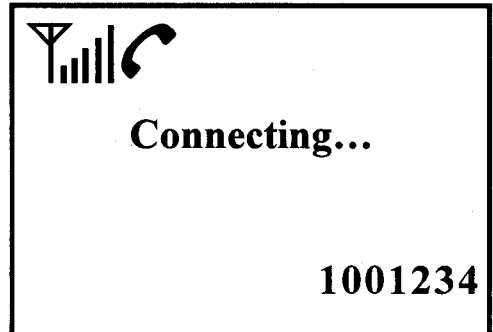

(Figure 3.1.5.1-2)

<Method 2>

- ▶ Press the button of the phone number stored in the address [1] ~ [9], and then press the [SND/RDL] button.

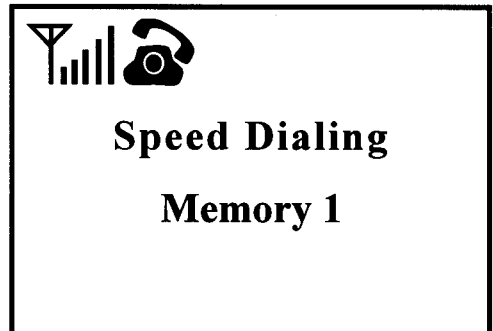

(Figure 3.1.5.1-3)

- ▶ The speaker phone operates automatically and the phone number stored in the Phone Book is connected.

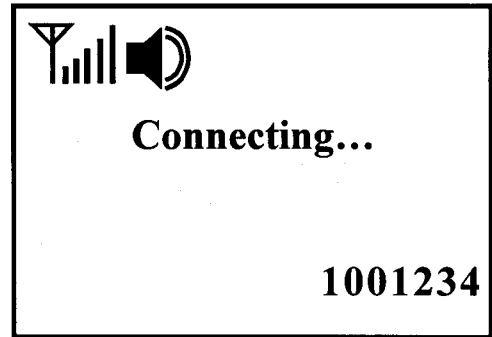

(Figure 3.1.5.1-4)

3.1.5.2 Two-Touch Dialing

This function allows you to simply make a call using the phone numbers stored in addresses 10 through 99.

<Method 1>

- ▶ Pick up the handset or press the [SPK] button.
- ▶ Press the first number shortly, and then press the second number over 2 seconds of the phone number stored in any of address [10] ~ [99].

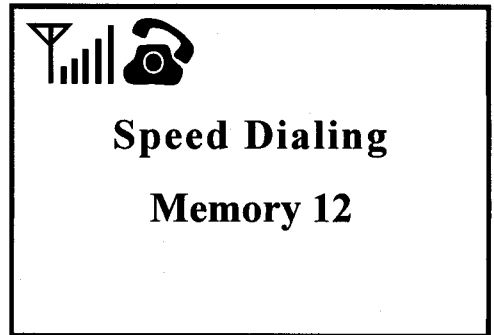

(Figure 3.1.5.2-1)

(Example)

When you want to make a call to the number stored in address [12], press the [1] button shortly and press the [2] button for over 2 seconds or press the two buttons, and then press the [SND/RDL] button.