

# FCC Radio Test Report

## FCC ID: PU5-TP00118A

**Report No.** : BTL-FCCP-3-2010T022  
**Equipment** : Notebook Computer / Tablet PC  
**Model Name** : TP00118A, TP00118A\* (The "\*" can be 0-9、A-Z、a-z、'、-、`、 or Blank, for market use only)  
**Brand Name** : Lenovo  
**Applicant** : Wistron Corporation  
**Address** : 21F., No. 88, Sec. 1, HsinTai 5th Rd., Hsichih Dist, New Taipei City 221, Taiwan  
**Radio Function** : WCDMA Band IV, LTE Band 4, 7, 12, 13, 17, 30, 41, 66  
**FCC Rule Part(s)** : 47 CFR FCC Part 27 Subpart D  
47 CFR FCC Part 27 Subpart F  
47 CFR FCC Part 27 Subpart H  
47 CFR FCC Part 27 Subpart L  
47 CFR FCC Part 27 Subpart M  
**Measurement Procedure(s)** : ANSI C63.26-2015  
ANSI/TIA-603-E-2016  
FCC KDB 971168 D01 Power Meas License Digital Systems v03r01  
**Date of Receipt** : 2020/10/8  
**Date of Test** : 2020/10/8 ~ 2020/11/18  
**Issued Date** : 2020/12/9

The above equipment has been tested and found in compliance with the requirement of the above standards by BTL Inc.

**Prepared by** :

  
Peter Chen, Engineer



**Approved by** :

  
Scott Hsu, Manager

**BTL Inc.**

No.18, Ln. 171, Sec. 2, Jiuzong Rd., Neihu Dist., Taipei City 114, Taiwan

Tel: +886-2-2657-3299

Fax: +886-2-2657-3331

Web: www.newbtl.com

**Declaration**

**BTL** represents to the client that testing is done in accordance with standard procedures as applicable and that test instruments used has been calibrated with standards traceable to international standard(s) and/or national standard(s).

**BTL's** reports apply only to the specific samples tested under conditions. It is manufacture's responsibility to ensure that additional production units of this model are manufactured with the identical electrical and mechanical components. **BTL** shall have no liability for any declarations, inferences or generalizations drawn by the client or others from **BTL** issued reports.

This report is the confidential property of the client. As a mutual protection to the clients, the public and ourselves, the test report shall not be reproduced, except in full, without our written approval.

**BTL's** laboratory quality assurance procedures are in compliance with the **ISO/IEC 17025** requirements, and accredited by the conformity assessment authorities listed in this test report.

**BTL** is not responsible for the sampling stage, so the results only apply to the sample as received.

The information, data and test plan are provided by manufacturer which may affect the validity of results, so it is manufacturer's responsibility to ensure that the apparatus meets the essential requirements of applied standards and in all the possible configurations as representative of its intended use.

**Limitation**

For the use of the authority's logo is limited unless the Test Standard(s)/Scope(s)/Item(s) mentioned in this test report is (are) included in the conformity assessment authorities acceptance respective.

Please note that the measurement uncertainty is provided for informational purpose only and are not use in determining the Pass/Fail results.

**CONTENTS**

REPORT ISSUED HISTORY	4
1 SUMMARY OF TEST RESULTS	5
1.1 TEST FACILITY	6
1.2 MEASUREMENT UNCERTAINTY	6
1.3 TEST ENVIRONMENT CONDITIONS	6
2 GENERAL INFORMATION	7
2.1 DESCRIPTION OF EUT	7
2.2 TEST MODES	8
2.3 BLOCK DIAGRAM SHOWING THE CONFIGURATION OF SYSTEM TESTED	9
2.4 SUPPORT UNITS	9
3 AC POWER LINE CONDUCTED EMISSIONS TEST	10
3.1 LIMIT	10
3.2 TEST PROCEDURE	10
3.3 DEVIATION FROM TEST STANDARD	10
3.4 TEST SETUP	11
3.5 TEST RESULT	11
4 RADIATED SPURIOUS EMISSIONS MEASUREMENT	12
4.1 LIMIT	12
4.2 TEST PROCEDURE	12
4.3 DEVIATION FROM TEST STANDARD	12
4.4 TEST SETUP	13
4.5 EUT OPERATING CONDITIONS	13
4.6 TEST RESULT	13
5 LIST OF MEASURING EQUIPMENTS	14
6 EUT TEST PHOTO	15
7 EUT PHOTOS	15
APPENDIX A AC POWER LINE CONDUCTED EMISSIONS	16
APPENDIX B RADIATED SPURIOUS EMISSIONS	21

### REPORT ISSUED HISTORY

Report Version	Description	Issued Date
R00	Original Issue.	2020/12/9

## 1 SUMMARY OF TEST RESULTS

Test procedures according to the technical standards.

FCC Clause No	Description	Test Result	Judgement	Remark
15.207	AC Power Line Conducted Emissions	APPENDIX A	Pass	-----
2.1053 27.53(a)(4) 27.53(c)(2) 27.53(f) 27.53(g) 27.53(h) 27.53(m)(4)	Radiated Spurious Emissions	APPENDIX B	Pass	-----

**NOTE:**

- (1) "N/A" denotes test is not applicable in this Test Report.
- (2) The report format version is TP.1.1.1.
- (3) The spot check test channels were verified based on the worst channel results reported in the original FCC ID (ZMOL850GL) filing test report.  
Since the RF module has been certificated, after evaluation, above test items were criticized and reconfirmed in this report.
- (4) After spot check, this revision does not change original radio parameters.

### 1.1 TEST FACILITY

The test facilities used to collect the test data in this report:

No. 68-1, Ln. 169, Sec. 2, Datong Rd., Xizhi Dist., New Taipei City 221, Taiwan  
 The test sites and facilities are covered under FCC RN: 355421 and DN: TW1099.

C05     
  CB08     
  CB11     
  CB15     
  CB16

### 1.2 MEASUREMENT UNCERTAINTY

The reported uncertainty of measurement  $y \pm U$ , where expanded uncertainty  $U$  is based on a standard uncertainty multiplied by a coverage factor of  $k = 2$ , providing a level of confidence of approximately **95 %**. The measurement instrumentation uncertainty considerations contained in CISPR 16-4-2. The BTL measurement uncertainty is less than the CISPR 16-4-2  $U_{cispr}$  requirement.

A. AC power line conducted emissions test:

Test Site	Method	Measurement Frequency Range	U (dB)
C05	CISPR	150 kHz ~ 30MHz	3.44

B. Radiated emissions test :

Test Site	Measurement Frequency Range	U,(dB)
CB15	0.03 GHz ~ 0.2 GHz	4.17
	0.2 GHz ~ 1 GHz	4.72
	1 GHz ~ 6 GHz	5.21
	6 GHz ~ 18 GHz	5.51
	18 GHz ~ 26 GHz	3.69
	26 GHz ~ 40 GHz	4.23

NOTE:

Unless specifically mentioned, the uncertainty of measurement has not been taken into account to declare the compliance or non-compliance to the specification.

### 1.3 TEST ENVIRONMENT CONDITIONS

Test Item	Environment Condition	Test Voltage	Tested by
AC Power Line Conducted Emissions	24 °C, 64 %	AC 120V	Nero Hsieh
Radiated Spurious Emissions	Refer to data	AC 120V	John Chuang

## 2 GENERAL INFORMATION

### 2.1 DESCRIPTION OF EUT

Equipment	Notebook Computer / Tablet PC		
Model Name	TP00118A, TP00118A* (The "*" can be 0-9、A-Z、a-z、' - '、 or Blank, for market use only)		
Brand Name	Lenovo		
Model Difference	Different model distribute to different area.		
Power Source	DC voltage supplied from External Power Supply. (Lenovo/ADLX65YDC3D)		
Power Rating	I/P: 100-240V~1.8A 50-60Hz O/P: 20.0V---3.25A 65.0W / 15.0V---3.0A / 9.0V---2.0A / 5.0V---2.0A 10.0W		
Products Covered	1 * Keyboard 1 * Adapter: Lenovo/ADLX65YDC3D		
WIFI+BT Module	Intel® Wi-Fi 6 AX201 / AX201D2W		
WWAN Module	Fibocom / L850-GL		
NFC Module	FOXCONN / T77H747		
Operation Frequency	Band	UL Frequency (MHz)	DL Frequency (MHz)
	WCDMA IV	1710 ~ 1755	2110 ~ 2155
	LTE 4	1710 ~ 1755	2110 ~ 2155
	LTE 7	2500 ~ 2570	2620 ~ 2690
	LTE 12	699 ~ 716	729 ~ 746
	LTE 13	777 ~ 787	746 ~ 756
	LTE 17	704 ~ 716	734 ~ 746
	LTE 30	2305 ~ 2315	2350 ~ 2360
	LTE 41	2496 ~ 2690	-
LTE 66	1710 ~ 1780	2110 ~ 2200	
Test Model	TP00118A		
Sample Status	Engineering Sample		
EUT Modification(s)	N/A		

**NOTE:**

(1) For a more detailed features description, please refer to the manufacturer's specifications or the user's manual.

(2) Table for Filed Antenna:

Antenna	Manufacture	P/N	Type	Connector	Gain (dBi)	Note
Main	Wistron Neweb Corporation	025.901QB.0001	PIFA	I-PEX	-0.55	WCDMA Band IV
					-1.51	LTE Band 4
					-3.89	LTE Band 7
					-3.43	LTE Band 12
					-3.83	LTE Band 13
					-0.86	LTE Band 17
					-1.06	LTE Band 30
					-0.55	LTE Band 41
Aux	Wistron Neweb Corporation	025.901QC.0001	PIFA	I-PEX	-	RX only

**2.2 TEST MODES**

Test Items	Band	Test Mode	Note
AC Power Line Conducted Emissions	-	Normal/Idle	-
Radiated Spurious Emissions	WCDMA Band IV	TX Mode (CH 1537/1638/1738)	-
	LTE Band 4	TX Mode (CH 20050/20175/20300)	-
	LTE Band 7	TX Mode (CH 20850/21100/21350)	-
	LTE Band 12	TX Mode (CH 23060/23095/23130)	-
	LTE Band 13	TX Mode (CH 23230)	-
	LTE Band 17	TX Mode (CH 23780/23790/23800)	-
	LTE Band 30	TX Mode (CH 27710)	-
	LTE Band 41	TX Mode (CH 39750/40620/41490)	-
	LTE Band 66	TX Mode (CH 132072/132322/132572)	-

**NOTE:**

- (1) The Radiated emissions test was verified based on the worst conducted power and Bandwidth test results reported in the original report.
- (2) All X, Y, Z and Stand axes are evaluated, but only the worst case (WCDMA: X axis, LTE Band 4/7/30/41/66: X axis, LTE Band 12/13/17: Stand axis) is recorded.



**2.3 BLOCK DIAGRAM SHOWING THE CONFIGURATION OF SYSTEM TESTED**

Equipment letters and Cable numbers refer to item numbers described in the tables of clause 2.4.

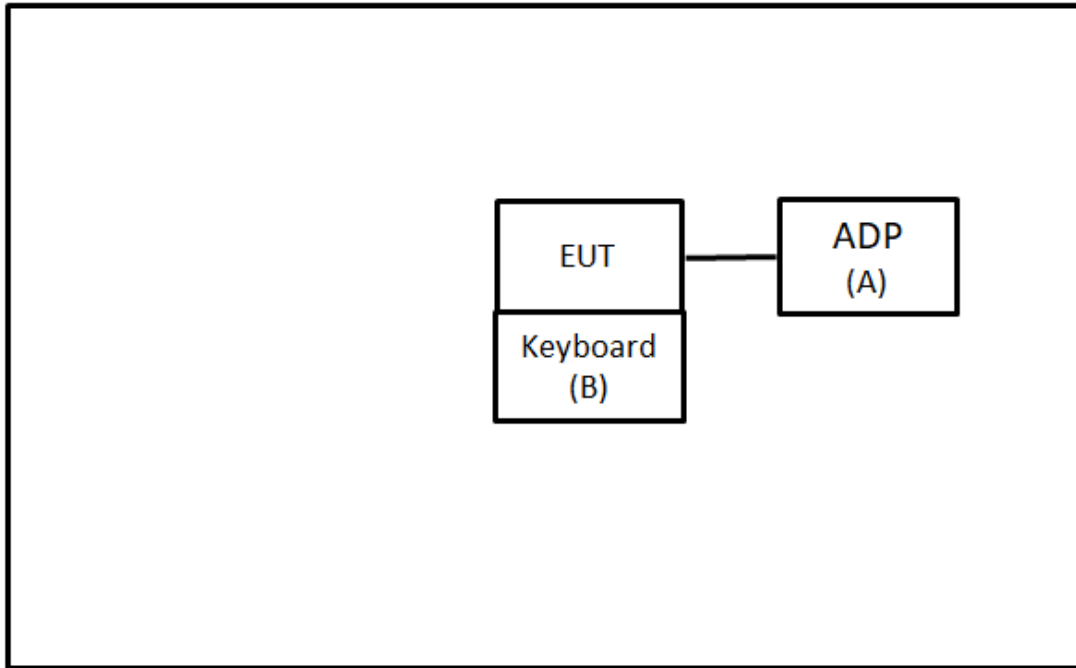

**2.4 SUPPORT UNITS**

Item	Equipment	Brand	Model No.	Series No.	Remarks
A	ADP	Lenovo	PA5352E-1AC3	N/A	Supplied by test requester.
B	Keyboard	N/A	ThinkPad-1	N/A	Supplied by test requester.

Item	Shielded	Ferrite Core	Length	Cable Type	Remarks
-	-	-	-	-	-

### 3 AC POWER LINE CONDUCTED EMISSIONS TEST

#### 3.1 LIMIT

Frequency (MHz)	Limit (dB $\mu$ V)	
	Quasi-peak	Average
0.15 - 0.5	66 - 56 *	56 - 46 *
0.50 - 5.0	56	46
5.0 - 30.0	60	50

**NOTE:**

- (1) The tighter limit applies at the band edges.
- (2) The limit of " \* " marked band means the limitation decreases linearly with the logarithm of the frequency in the range.
- (3) The test result calculated as following:  
 Measurement Value = Reading Level + Correct Factor  
 Correct Factor = Insertion Loss + Cable Loss + Attenuator Factor (if use)  
 Margin Level = Measurement Value – Limit Value  
 Calculation example:

Reading Level		Correct Factor		Measurement Value
38.22	+	3.45	=	41.67

Measurement Value		Limit Value		Margin Level
41.67	-	60	=	-18.33

The following table is the setting of the receiver.

Receiver Parameter	Setting
Attenuation	10 dB
Start Frequency	0.15 MHz
Stop Frequency	30 MHz
IF Bandwidth	9 KHz

#### 3.2 TEST PROCEDURE

- a. The EUT was placed 0.8 m above the horizontal ground plane with the EUT being connected to the power mains through a line impedance stabilization network (LISN).  
 All other support equipment were powered from an additional LISN(s).  
 The LISN provides 50 Ohm/50uH of impedance for the measuring instrument.
- b. Interconnecting cables that hang closer than 40 cm to the ground plane shall be folded back and forth in the center forming a bundle to keep the cable above 40 cm.
- c. Excess I/O cables that are not connected to a peripheral shall be bundled in the center.  
 The end of the cable will be terminated, using the correct terminating impedance.  
 The overall length shall not exceed 1 m.
- d. The LISN is spaced at least 80 cm from the nearest part of the EUT chassis.
- e. For the actual test configuration, please refer to the related Item - EUT TEST PHOTO.

**NOTE:**

- (1) In the results, each reading is marked as Peak, QP or AVG per the detector used.  
 BW=9 kHz (6 dB Bandwidth)
- (2) All readings are Peak unless otherwise stated QP or AVG in column of Note. Both the QP and the AVG readings must be less than the limit for compliance.

#### 3.3 DEVIATION FROM TEST STANDARD

No deviation.

### 3.4 TEST SETUP

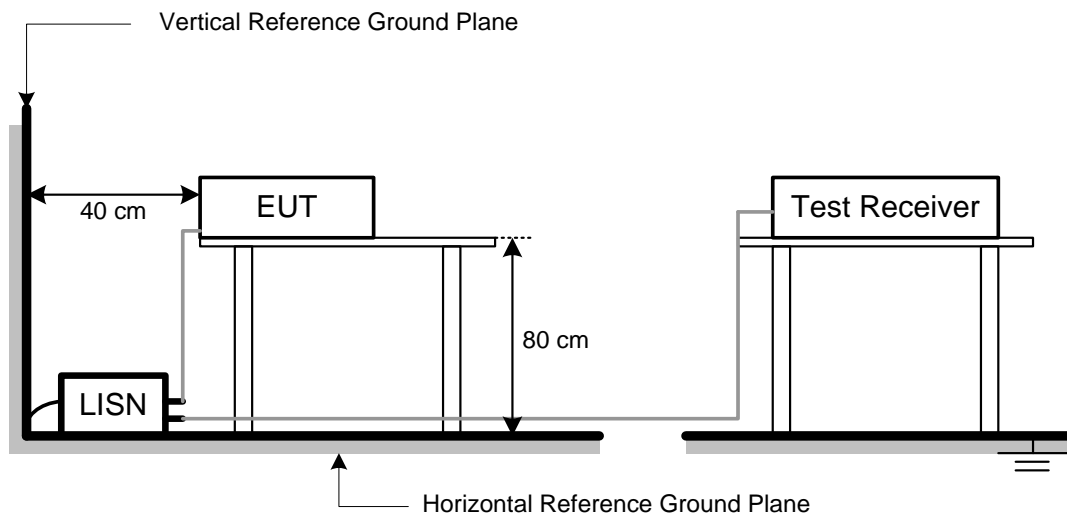

### 3.5 TEST RESULT

Please refer to the APPENDIX A.

## 4 RADIATED SPURIOUS EMISSIONS MEASUREMENT

### 4.1 LIMIT

The power of any emission outside of the authorized operating frequency ranges must be attenuated below the transmitting power (P) by a factor of at least  $43 + 10 \log(P)$  dB. The emission limit equal to -13dBm.

NOTE:

(1) The test result calculated as following:

Measurement Value = Reading Level + Correct Factor

Correct Factor = Antenna Factor + Cable Loss - Amplifier Gain(if use)

Margin Level = Measurement Value - Limit Value

Calculation example:

Reading Level		Correct Factor		Measurement Value
-50.43	+	-2.11	=	-52.54

Measurement Value		Limit Value		Margin Level
-52.54	-	-13	=	-39.54

### 4.2 TEST PROCEDURE

The testing follows FCC KDB 971168 v03r01 Section 6.2.

- a. In the semi-anechoic chamber, EUT placed on the 0.8m height of Turn Table, rotated the table around 360 degrees to search the maximum radiation power and receiver antenna shall be rotated vertical and horizontal polarization and moved height from 1m to 4m to find the maximum polar radiated power. The "Read Value" is the spectrum reading the maximum power value.
- b. The substitution horn antenna is substituted for EUT at the same position and signals generator export the CW signal to the substitution antenna via a TX cable. Rotated the Turn Table and moved receiving antenna to find the maximum radiation power. Adjust output power level of S.G to get a Value of spectrum reading equal to "Read Value " of step a. Record the power level of S.G
- c. EIRP = Output power level of S.G - TX cable loss + Antenna gain of substitution horn.
- d. ERP power can be calculated form EIRP power by subtracting the gain of dipole,  
ERP power = EIRP power - 2.15 dBi.
- e. The resolution bandwidth and video bandwidth of test receiver/spectrum analyzer is 1 MHz / 3 MHz.

### 4.3 DEVIATION FROM TEST STANDARD

No deviation.

## 4.4 TEST SETUP

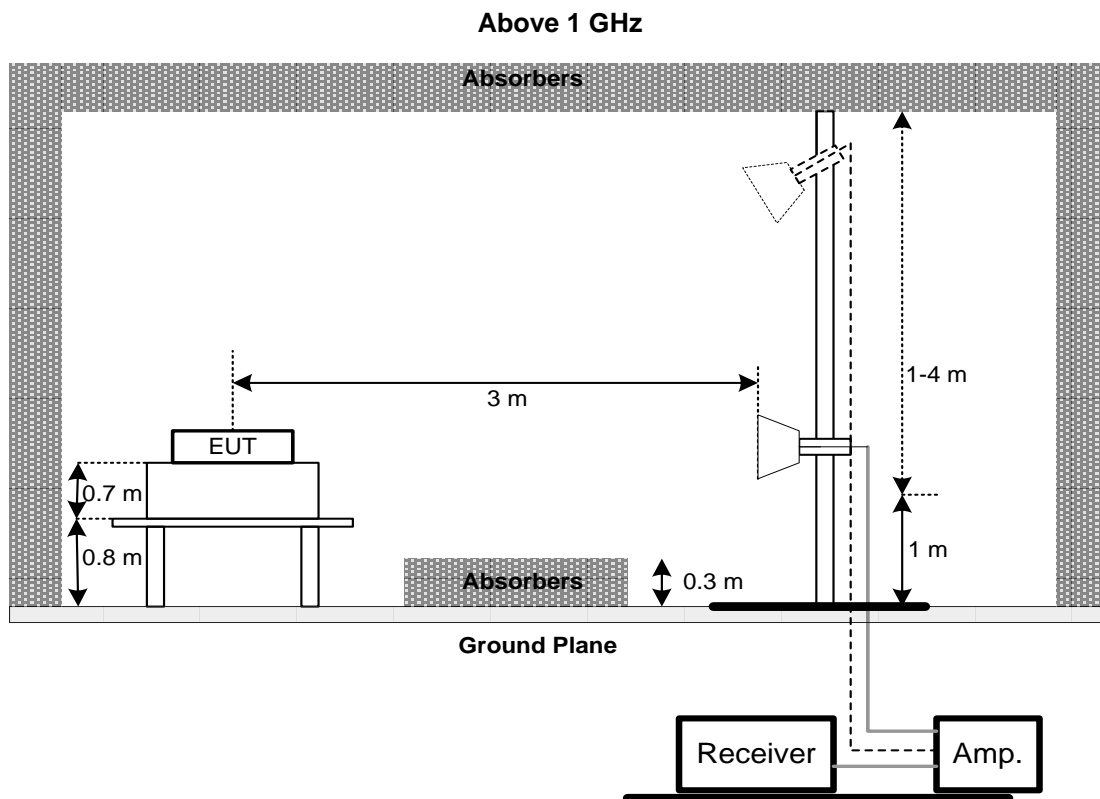
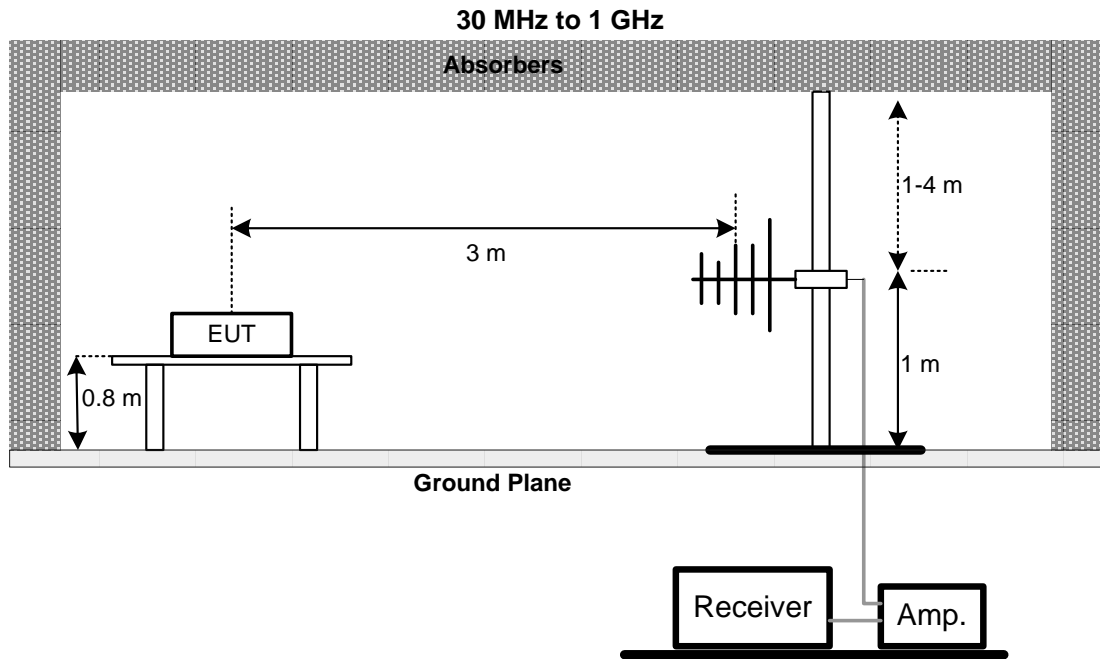

## 4.5 EUT OPERATING CONDITIONS

The EUT was programmed to be in continuously transmitting mode.

## 4.6 TEST RESULT

Please refer to the APPENDIX B

## 5 LIST OF MEASURING EQUIPMENTS

AC Power Line Conducted Emissions						
Item	Kind of Equipment	Manufacturer	Type No.	Serial No.	Calibrated Date	Calibrated Until
1	TWO-LINE V-NETWORK	R&S	ENV216	101050	2020/6/11	2021/6/10
2	Test Cable	EMCI	EMC400-BM-BM-5000	170501	2020/6/8	2021/6/7
3	EMI Test Receiver	R&S	ESR7	101433	2019/12/13	2020/12/12
4	Measurement Software	EZ	EZ EMC (Version NB-03A1-01)	N/A	N/A	N/A

Radiated Emissions						
Item	Kind of Equipment	Manufacturer	Type No.	Serial No.	Calibrated Date	Calibrated Until
1	Preamplifier	EMCI	EMC001340	980555	2020/4/10	2021/4/9
2	Preamplifier	EMCI	EMC02325B	980217	2020/4/10	2021/4/9
3	Preamplifier	EMCI	EMC012645B	980267	2020/4/10	2021/4/9
4	Test Cable	EMCI	EMC-SM-SM-1000	180809	2020/4/10	2021/4/9
5	Test Cable	EMCI	EMC104-SM-SM-3000	151205	2020/4/10	2021/4/9
6	Test Cable	EMCI	EMC-SM-SM-7000	180408	2020/4/10	2021/4/9
7	MXE EMI Receiver	Agilent	N9038A	MY554200087	2020/6/10	2021/6/9
8	Signal Analyzer	Agilent	N9010A	MY56480554	2020/8/25	2021/8/24
9	Loop Ant	EMCO	6502	274	2020/6/16	2021/6/15
10	Horn Ant	SCHWARZBECK	BBHA 9120D	9120D-1342	2020/6/12	2021/6/11
11	Trilog-Broadband Antenna	Schwarzbeck	VULB 9168	VULB 9168-352	2020/7/24	2021/7/23
12	5dB Attenuator	EMCI	EMCI-N-6-05	AT-N0625	2020/7/24	2021/7/23
13	8960 Series 10 Wireless Com Test Set	Agilent	E5515C	GB47390193	2020/6/4	2021/6/3
14	Radio Communication Analyzer (LTE)	Anritsu	MT8820C	6201525878	2020/6/3	2021/6/2
15	Measurement Software	EZ	EZ EMC (Version NB-03A1-01)	N/A	N/A	N/A

Remark: "N/A" denotes no model name, no serial no. or no calibration specified.  
All calibration period of equipment list is one year.

## **6 EUT TEST PHOTO**

Please refer to document Appendix No.: TP-2010T022-1 (APPENDIX-TEST PHOTOS).

## **7 EUT PHOTOS**

Please refer to document Appendix No.: EP-2010T022-1 (APPENDIX-EUT PHOTOS).

## **APPENDIX A AC POWER LINE CONDUCTED EMISSIONS**



Test Mode	Normal	Tested Date	2020/10/27
Test Frequency	-	Phase	Line

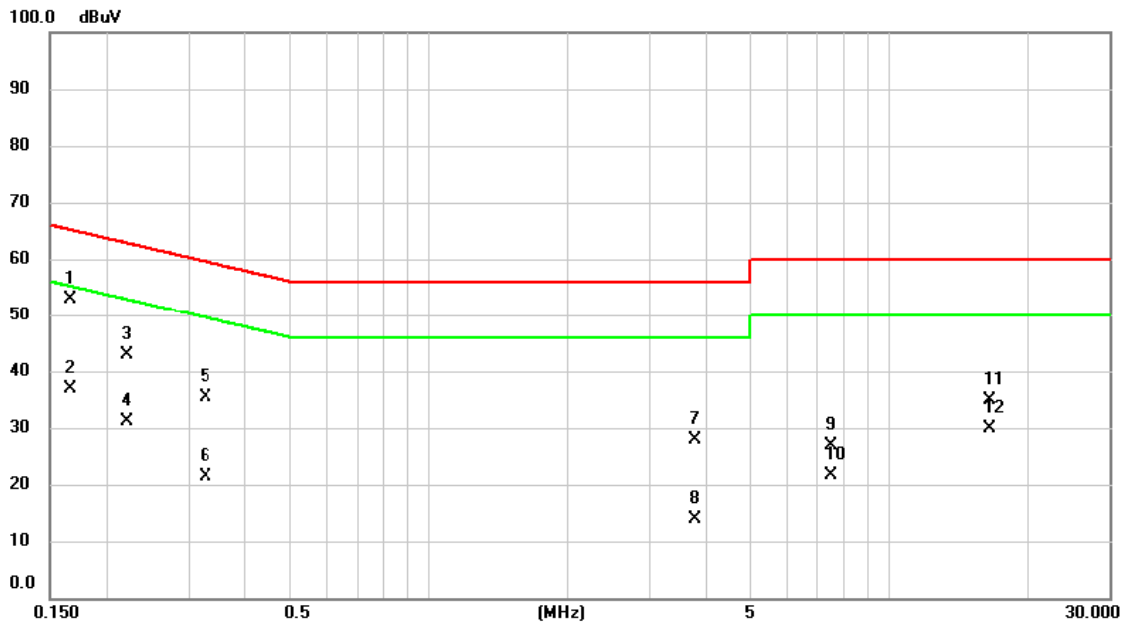

No.	Mk.	Freq. (MHz)	Reading Level (dBuV)	Correct Factor (dB)	Measurement (dBuV)	Limit (dBuV)	Over (dB)	Detector	Comment
1	*	0.1657	43.08	9.68	52.76	65.17	-12.41	QP	
2		0.1657	27.18	9.68	36.86	55.17	-18.31	AVG	
3		0.2197	33.31	9.67	42.98	62.83	-19.85	QP	
4		0.2197	21.38	9.67	31.05	52.83	-21.78	AVG	
5		0.3277	25.72	9.68	35.40	59.51	-24.11	QP	
6		0.3277	11.78	9.68	21.46	49.51	-28.05	AVG	
7		3.7747	18.13	9.79	27.92	56.00	-28.08	QP	
8		3.7747	4.14	9.79	13.93	46.00	-32.07	AVG	
9		7.4940	17.05	9.87	26.92	60.00	-33.08	QP	
10		7.4940	11.73	9.87	21.60	50.00	-28.40	AVG	
11		16.5705	24.90	9.95	34.85	60.00	-25.15	QP	
12		16.5705	19.93	9.95	29.88	50.00	-20.12	AVG	

**REMARKS:**

- (1) Measurement Value = Reading Level + Correct Factor.
- (2) Margin Level = Measurement Value - Limit Value.

Test Mode	Normal	Tested Date	2020/10/27
Test Frequency	-	Phase	Neutral

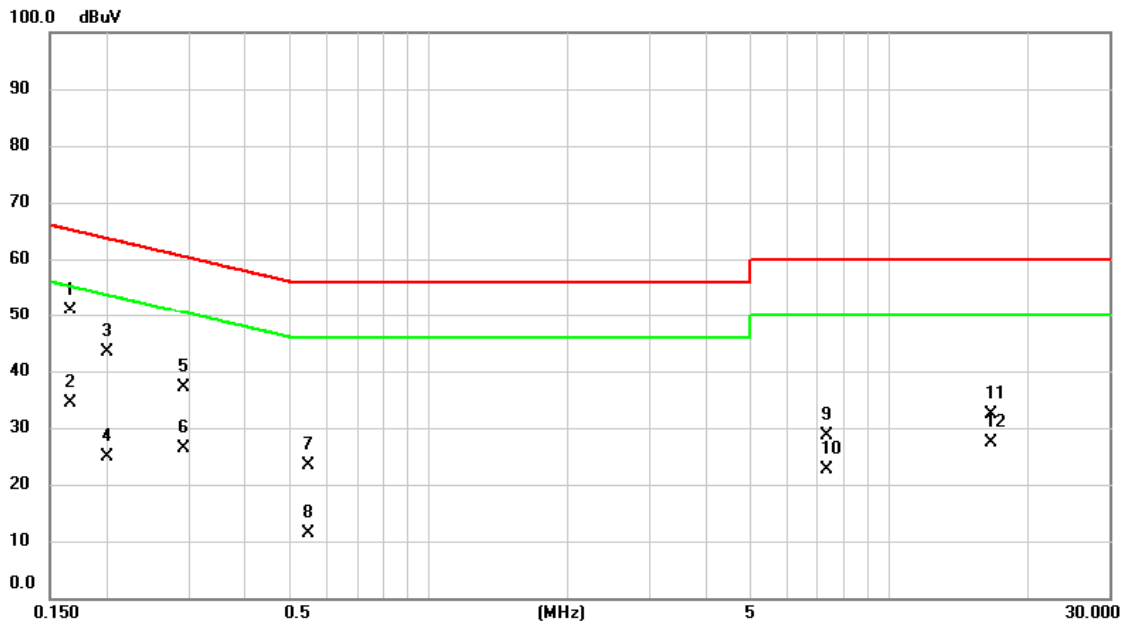

No. Mk.	Freq. MHz	Reading Level dBuV	Correct Factor dB	Measurement dBuV	Limit dBuV	Over dB	Detector	Comment
1 *	0.1658	41.32	9.68	51.00	65.17	-14.17	QP	
2	0.1658	24.67	9.68	34.35	55.17	-20.82	AVG	
3	0.1997	33.74	9.67	43.41	63.62	-20.21	QP	
4	0.1997	15.31	9.67	24.98	53.62	-28.64	AVG	
5	0.2917	27.55	9.69	37.24	60.48	-23.24	QP	
6	0.2917	16.77	9.69	26.46	50.48	-24.02	AVG	
7	0.5482	13.66	9.68	23.34	56.00	-32.66	QP	
8	0.5482	1.64	9.68	11.32	46.00	-34.68	AVG	
9	7.3230	18.87	9.87	28.74	60.00	-31.26	QP	
10	7.3230	12.78	9.87	22.65	50.00	-27.35	AVG	
11	16.5795	22.48	9.95	32.43	60.00	-27.57	QP	
12	16.5795	17.40	9.95	27.35	50.00	-22.65	AVG	

**REMARKS:**

- (1) Measurement Value = Reading Level + Correct Factor.
- (2) Margin Level = Measurement Value - Limit Value.

Test Mode	Idle	Tested Date	2020/10/27
Test Frequency	-	Phase	Line

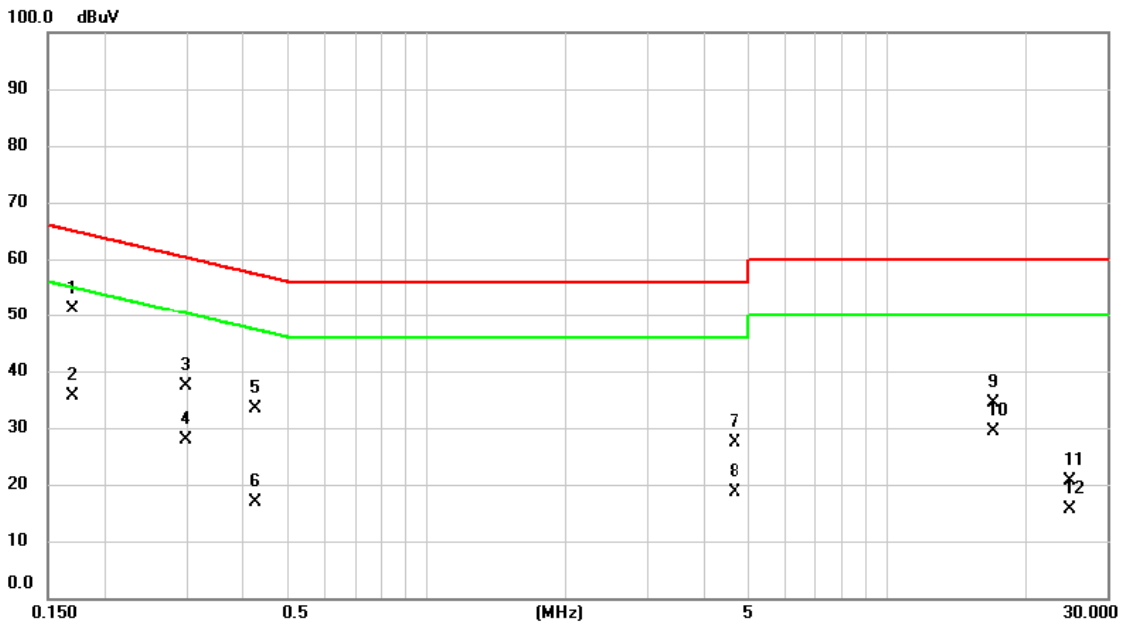

No.	Mk.	Freq. MHz	Reading Level dBuV	Correct Factor dB	Measure- ment dBuV	Limit dBuV	Over dB	Detector	Comment
1	*	0.1703	41.34	9.68	51.02	64.95	-13.93	QP	
2		0.1703	25.94	9.68	35.62	54.95	-19.33	AVG	
3		0.2985	27.81	9.69	37.50	60.28	-22.78	QP	
4		0.2985	18.07	9.69	27.76	50.28	-22.52	AVG	
5		0.4267	23.65	9.68	33.33	57.32	-23.99	QP	
6		0.4267	7.28	9.68	16.96	47.32	-30.36	AVG	
7		4.6500	17.59	9.81	27.40	56.00	-28.60	QP	
8		4.6500	8.88	9.81	18.69	46.00	-27.31	AVG	
9		17.0363	24.46	9.95	34.41	60.00	-25.59	QP	
10		17.0363	19.44	9.95	29.39	50.00	-20.61	AVG	
11		24.8595	10.68	9.94	20.62	60.00	-39.38	QP	
12		24.8595	5.67	9.94	15.61	50.00	-34.39	AVG	

**REMARKS:**

- (1) Measurement Value = Reading Level + Correct Factor.
- (2) Margin Level = Measurement Value - Limit Value.

Test Mode	Idle	Tested Date	2020/10/27
Test Frequency	-	Phase	Neutral

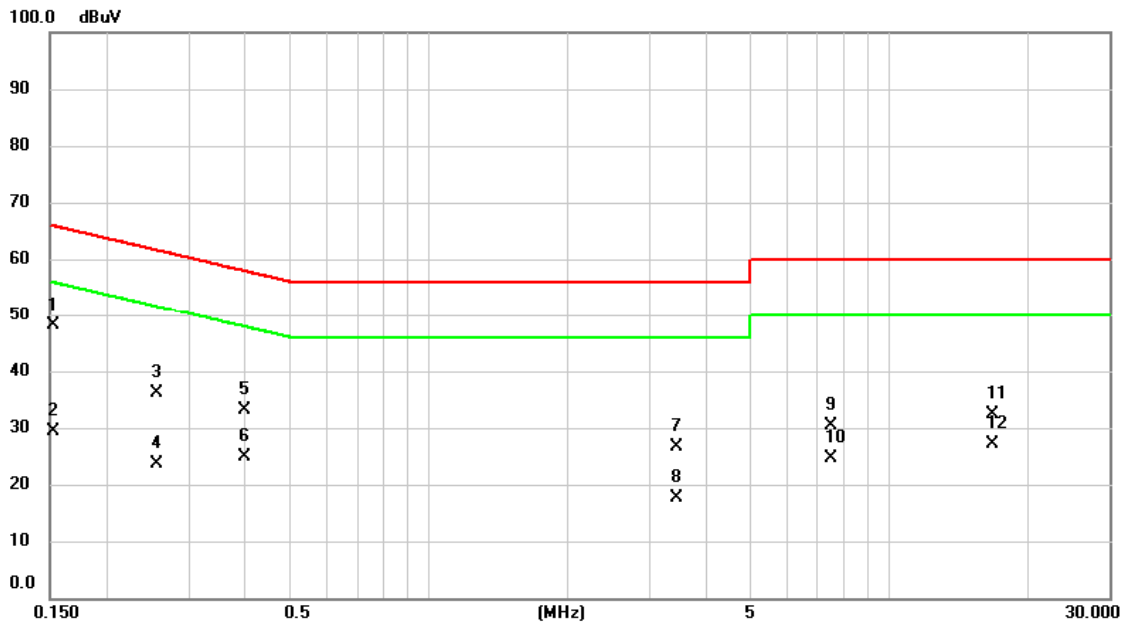

No.	Mk.	Freq. MHz	Reading Level dBuV	Correct Factor dB	Measure- ment dBuV	Limit dBuV	Over dB	Detector	Comment
1	*	0.1522	38.38	9.68	48.06	65.88	-17.82	QP	
2		0.1522	19.69	9.68	29.37	55.88	-26.51	AVG	
3		0.2562	26.48	9.68	36.16	61.55	-25.39	QP	
4		0.2562	13.96	9.68	23.64	51.55	-27.91	AVG	
5		0.3997	23.40	9.68	33.08	57.86	-24.78	QP	
6		0.3997	15.21	9.68	24.89	47.86	-22.97	AVG	
7		3.4440	16.77	9.77	26.54	56.00	-29.46	QP	
8		3.4440	7.85	9.77	17.62	46.00	-28.38	AVG	
9		7.4648	20.43	9.87	30.30	60.00	-29.70	QP	
10		7.4648	14.74	9.87	24.61	50.00	-25.39	AVG	
11		16.6965	22.37	9.95	32.32	60.00	-27.68	QP	
12		16.6965	17.24	9.95	27.19	50.00	-22.81	AVG	

**REMARKS:**

- (1) Measurement Value = Reading Level + Correct Factor.
- (2) Margin Level = Measurement Value - Limit Value.

## **APPENDIX B    RADIATED SPURIOUS EMISSIONS**

Test Mode	WCDMA Band IV	Test Date	2020/10/27
Test Channel	CH1638	Polarization	Vertical
Temp	20°C	Hum.	68%

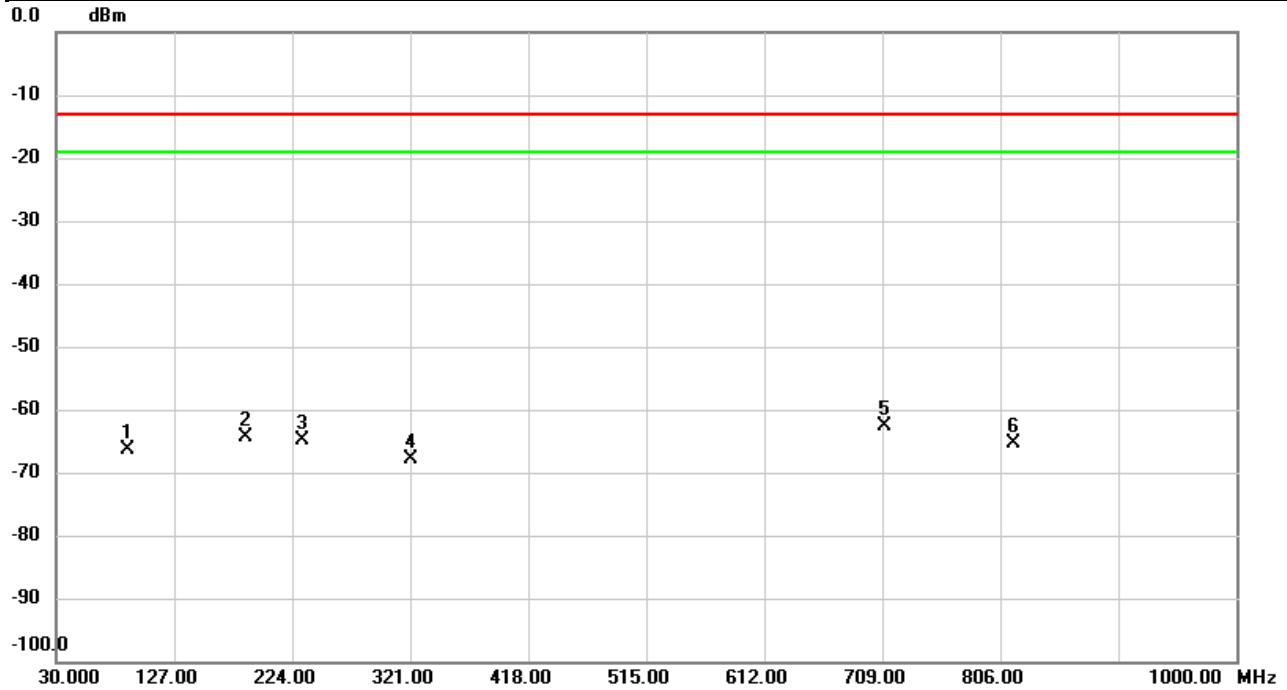

No.	Mk.	Freq. MHz	Reading Level dBm	Correct Factor dB	Measure- ment dBm	Limit dBm	Over dB	Detector	Comment
1		89.1700	-66.79	0.53	-66.26	-13.00	-53.26	peak	
2		186.1700	-70.36	6.11	-64.25	-13.00	-51.25	peak	
3		232.7300	-71.65	6.88	-64.77	-13.00	-51.77	peak	
4		321.9700	-77.09	9.33	-67.76	-13.00	-54.76	peak	
5	*	710.9400	-77.29	14.57	-62.72	-13.00	-49.72	peak	
6		816.6700	-76.89	11.51	-65.38	-13.00	-52.38	peak	

**REMARKS:**

- (1) Measurement Value = Reading Level + Correct Factor.
- (2) Margin Level = Measurement Value - Limit Value.

Test Mode	WCDMA Band IV	Test Date	2020/10/27
Test Channel	CH1638	Polarization	Horizontal
Temp	20°C	Hum.	68%

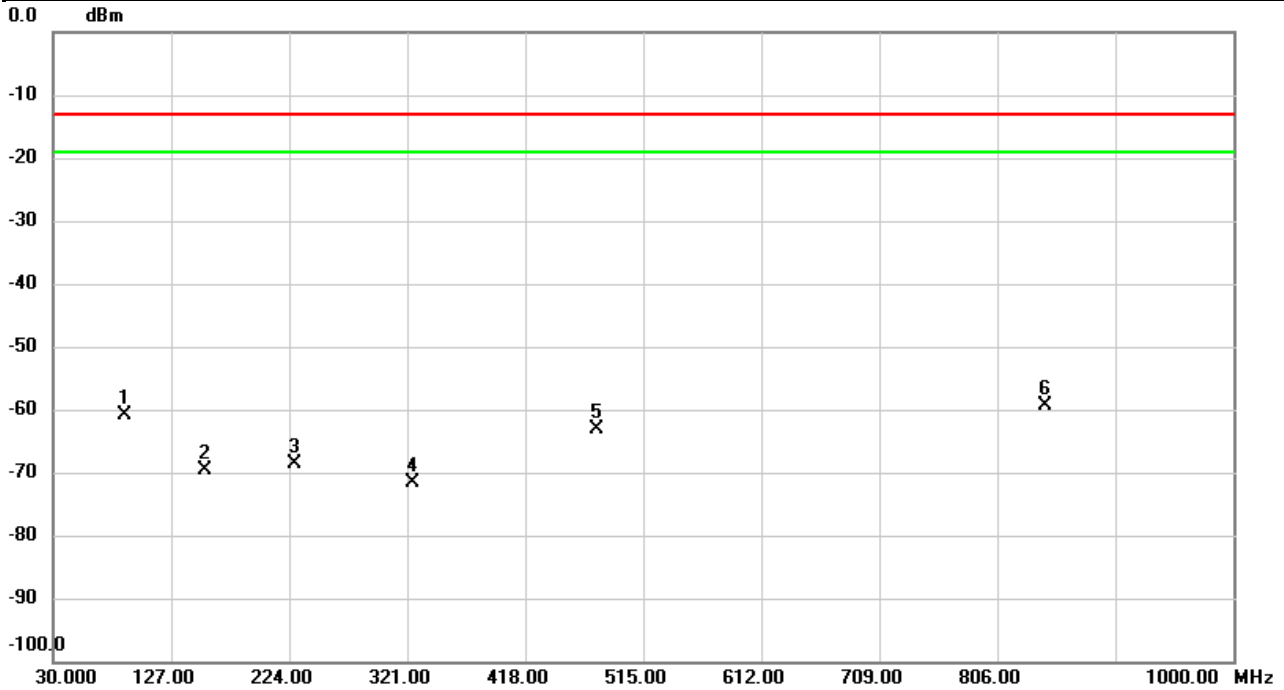

No.	Mk.	Freq. MHz	Reading Level dBm	Correct Factor dB	Measure- ment dBm	Limit dBm	Over dB	Detector	Comment
1		89.1700	-66.93	5.98	-60.95	-13.00	-47.95	peak	
2		154.1600	-74.46	4.94	-69.52	-13.00	-56.52	peak	
3		227.8800	-70.26	1.54	-68.72	-13.00	-55.72	peak	
4		324.8800	-76.22	4.61	-71.61	-13.00	-58.61	peak	
5		476.2000	-77.16	14.02	-63.14	-13.00	-50.14	peak	
6	*	845.7700	-77.80	18.47	-59.33	-13.00	-46.33	peak	

**REMARKS:**

- (1) Measurement Value = Reading Level + Correct Factor.
- (2) Margin Level = Measurement Value - Limit Value.

Test Mode	WCDMA Band IV	Test Date	2020/10/27
Test Channel	CH1537	Polarization	Vertical
Temp	20°C	Hum.	68%

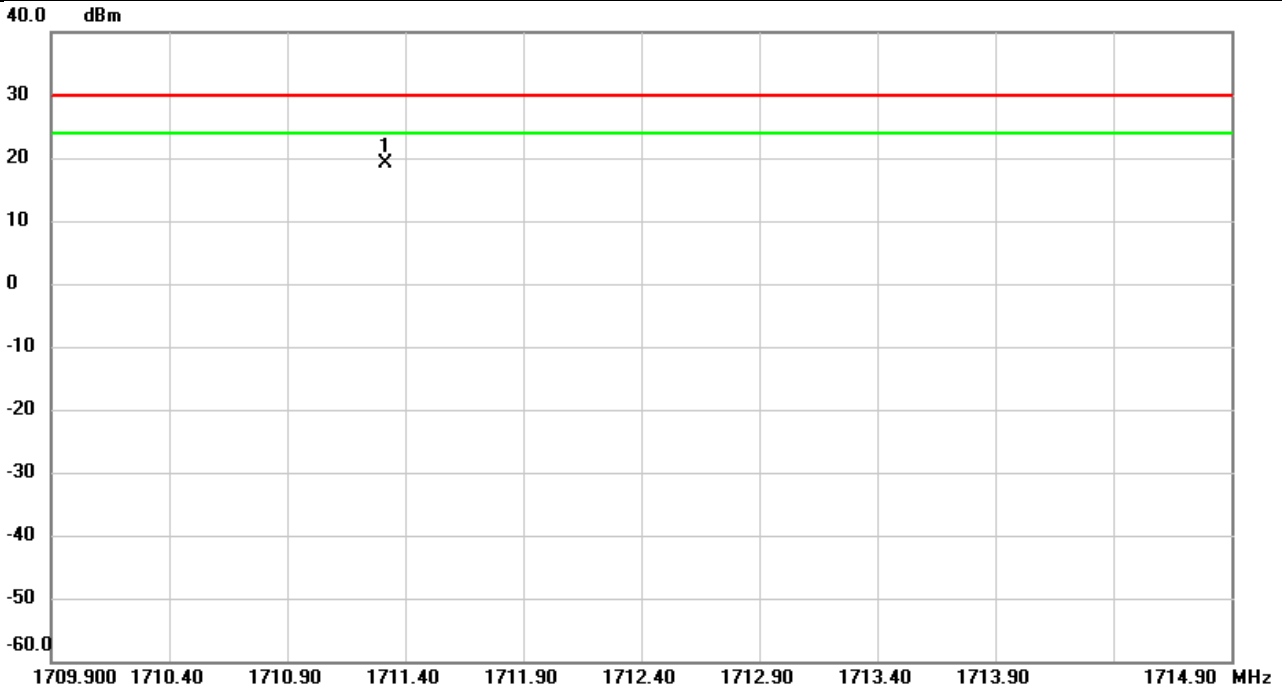

No.	Mk.	Freq. MHz	Reading Level dBm	Correct Factor dB	Measure- ment dBm	Limit dBm	Over dB	Detector	Comment
1	*	1711.320	-20.31	39.47	19.16	30.00	-10.84	peak	

REMARKS:

- (1) Measurement Value = Reading Level + Correct Factor.
- (2) Margin Level = Measurement Value - Limit Value.



Test Mode	WCDMA Band IV	Test Date	2020/10/27
Test Channel	CH1537	Polarization	Horizontal
Temp	20°C	Hum.	68%

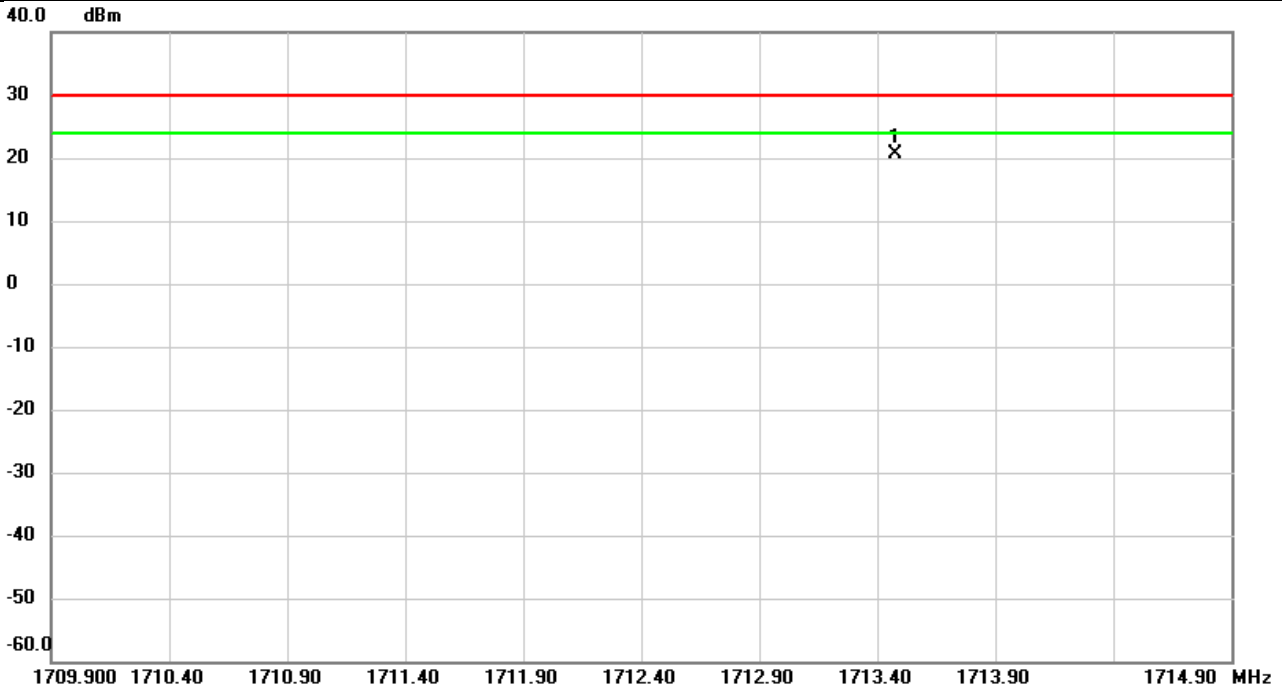

No.	Mk.	Freq.	Reading Level	Correct Factor	Measurement	Limit	Over	Detector	Comment
		MHz	dBm	dB	dBm	dBm	dB		
1	*	1713.475	-19.61	40.12	20.51	30.00	-9.49	peak	

REMARKS:

- (1) Measurement Value = Reading Level + Correct Factor.
- (2) Margin Level = Measurement Value - Limit Value.

Test Mode	WCDMA Band IV	Test Date	2020/10/27
Test Channel	CH1638	Polarization	Vertical
Temp	20°C	Hum.	68%

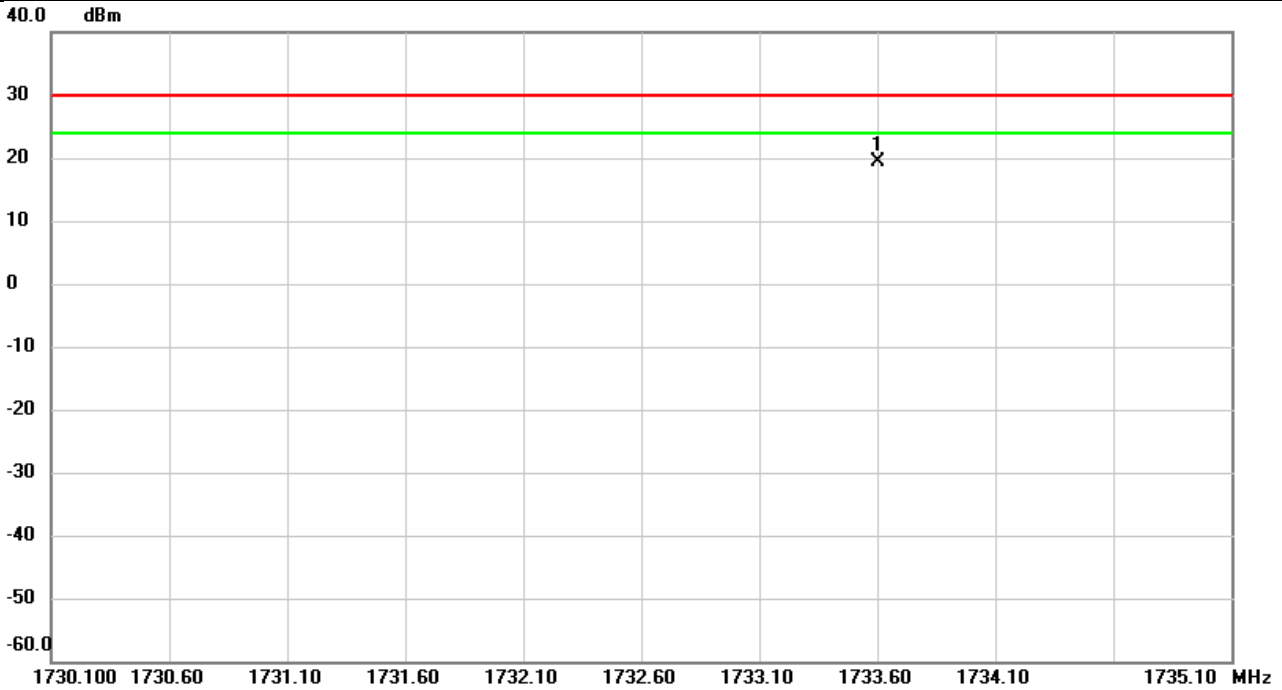

No.	Mk.	Freq.	Reading Level	Correct Factor	Measurement	Limit	Over	Detector	Comment
		MHz	dBm	dB	dBm	dBm	dB		
1	*	1733.605	-20.16	39.57	19.41	30.00	-10.59	peak	

**REMARKS:**

- (1) Measurement Value = Reading Level + Correct Factor.
- (2) Margin Level = Measurement Value - Limit Value.

Test Mode	WCDMA Band IV	Test Date	2020/10/27
Test Channel	CH1638	Polarization	Horizontal
Temp	20°C	Hum.	68%

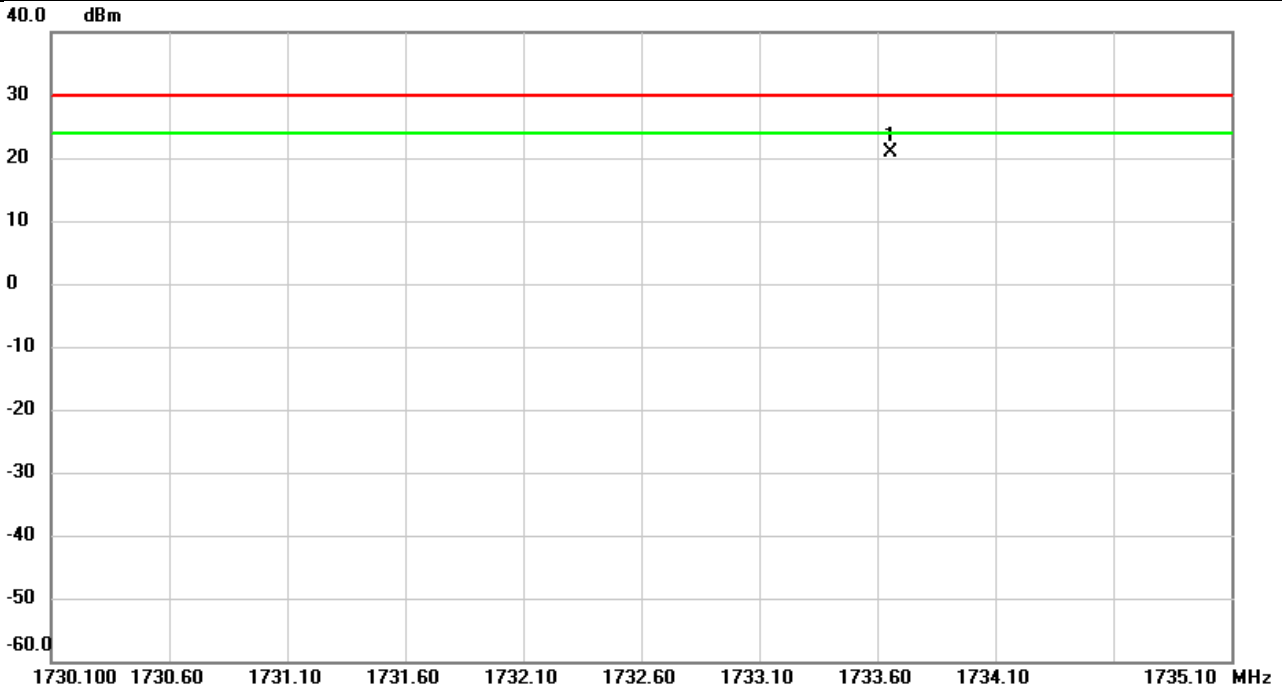

No.	Mk.	Freq. MHz	Reading Level dBm	Correct Factor dB	Measure- ment dBm	Limit dBm	Over dB	Detector	Comment
1	*	1733.655	-19.31	40.19	20.88	30.00	-9.12	peak	

REMARKS:

- (1) Measurement Value = Reading Level + Correct Factor.
- (2) Margin Level = Measurement Value - Limit Value.

Test Mode	WCDMA Band IV	Test Date	2020/10/27
Test Channel	CH1738	Polarization	Vertical
Temp	20°C	Hum.	68%

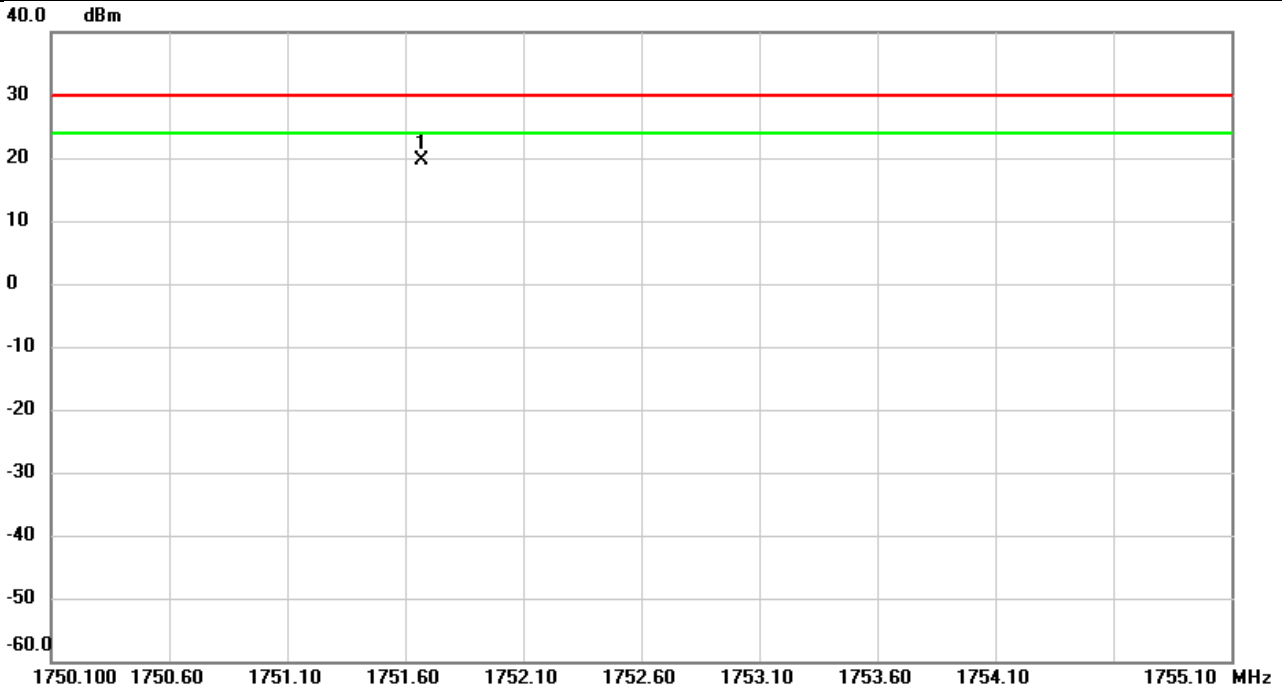

No.	Mk.	Freq.	Reading Level	Correct Factor	Measurement	Limit	Over	Detector	Comment
		MHz	dBm	dB	dBm	dBm	dB		
1	*	1751.670	-20.06	39.65	19.59	30.00	-10.41	peak	

REMARKS:

- (1) Measurement Value = Reading Level + Correct Factor.
- (2) Margin Level = Measurement Value - Limit Value.

Test Mode	WCDMA Band IV	Test Date	2020/10/27
Test Channel	CH1738	Polarization	Horizontal
Temp	20°C	Hum.	68%

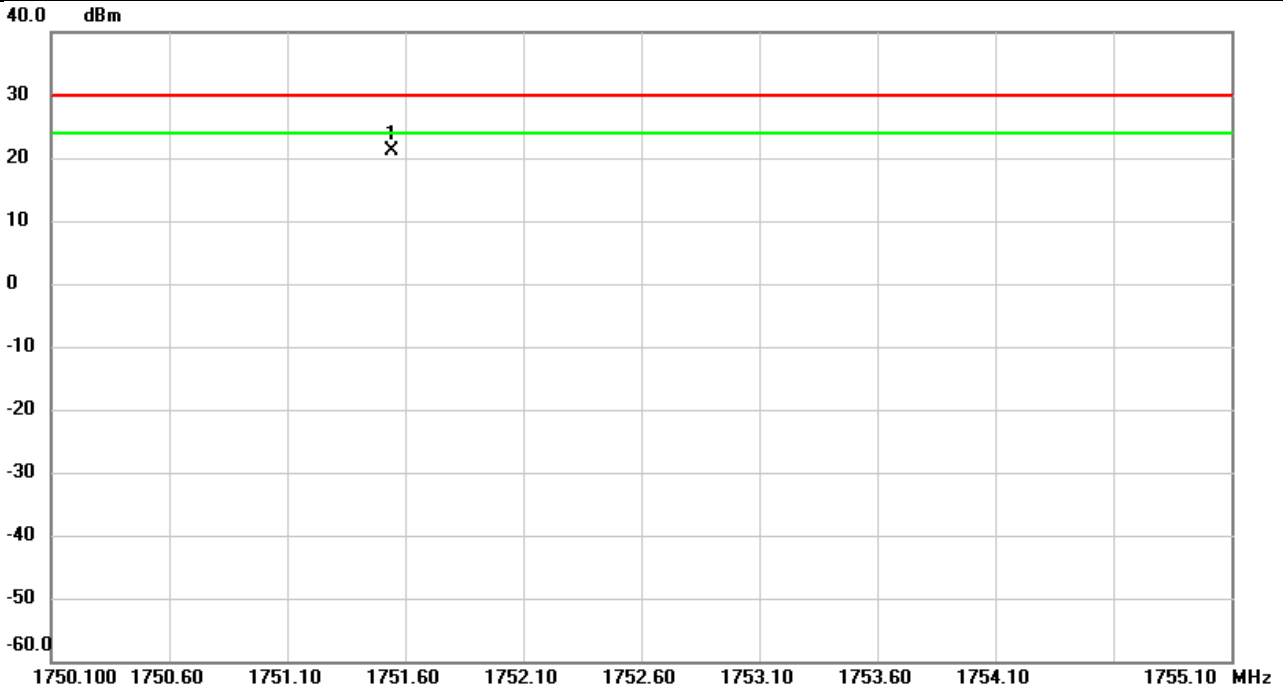

No.	Mk.	Freq.	Reading Level	Correct Factor	Measurement	Limit	Over	Detector	Comment
		MHz	dBm	dB	dBm	dBm	dB		
1	*	1751.540	-19.11	40.26	21.15	30.00	-8.85	peak	

REMARKS:

- (1) Measurement Value = Reading Level + Correct Factor.
- (2) Margin Level = Measurement Value - Limit Value.

Test Mode	WCDMA Band IV	Test Date	2020/10/27
Test Channel	CH1638	Polarization	Vertical
Temp	20°C	Hum.	68%

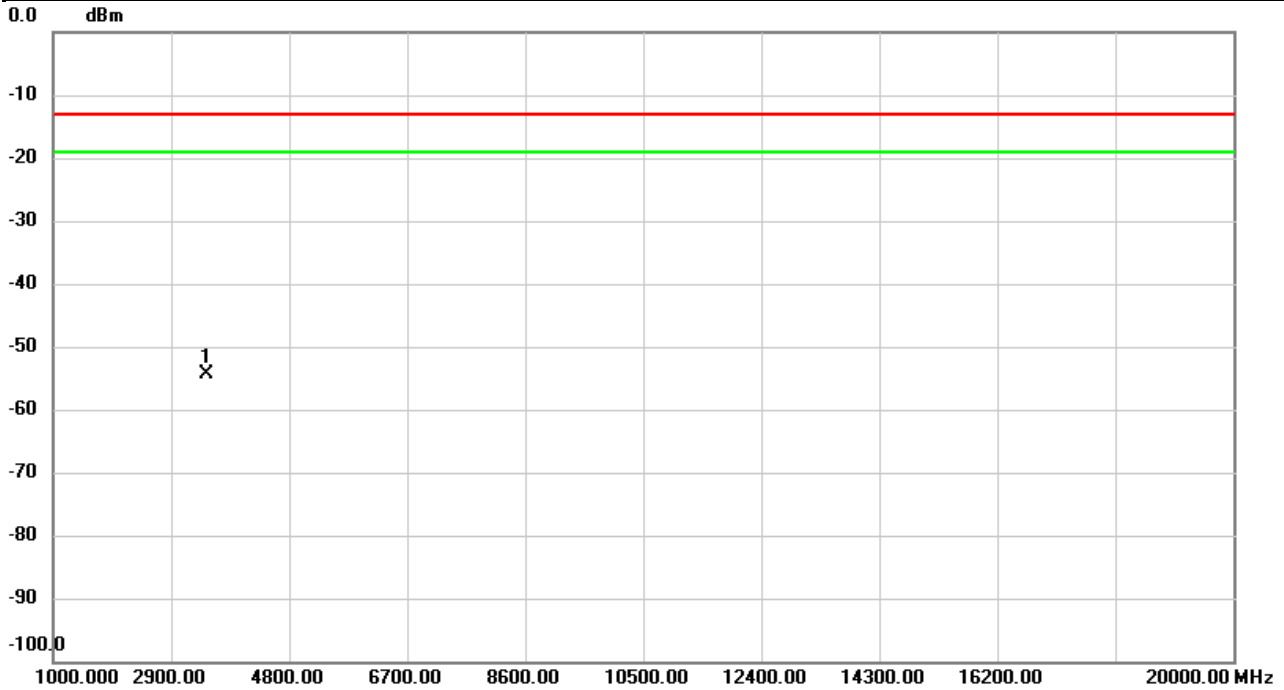

No.	Mk.	Freq.	Reading Level	Correct Factor	Measurement	Limit	Over	Detector	Comment
		MHz	dBm	dB	dBm	dBm	dB		
1	*	3470.000	-52.39	-1.94	-54.33	-13.00	-41.33	peak	

REMARKS:

- (1) Measurement Value = Reading Level + Correct Factor.
- (2) Margin Level = Measurement Value - Limit Value.

Test Mode	WCDMA Band IV	Test Date	2020/10/27
Test Channel	CH1638	Polarization	Horizontal
Temp	20°C	Hum.	68%

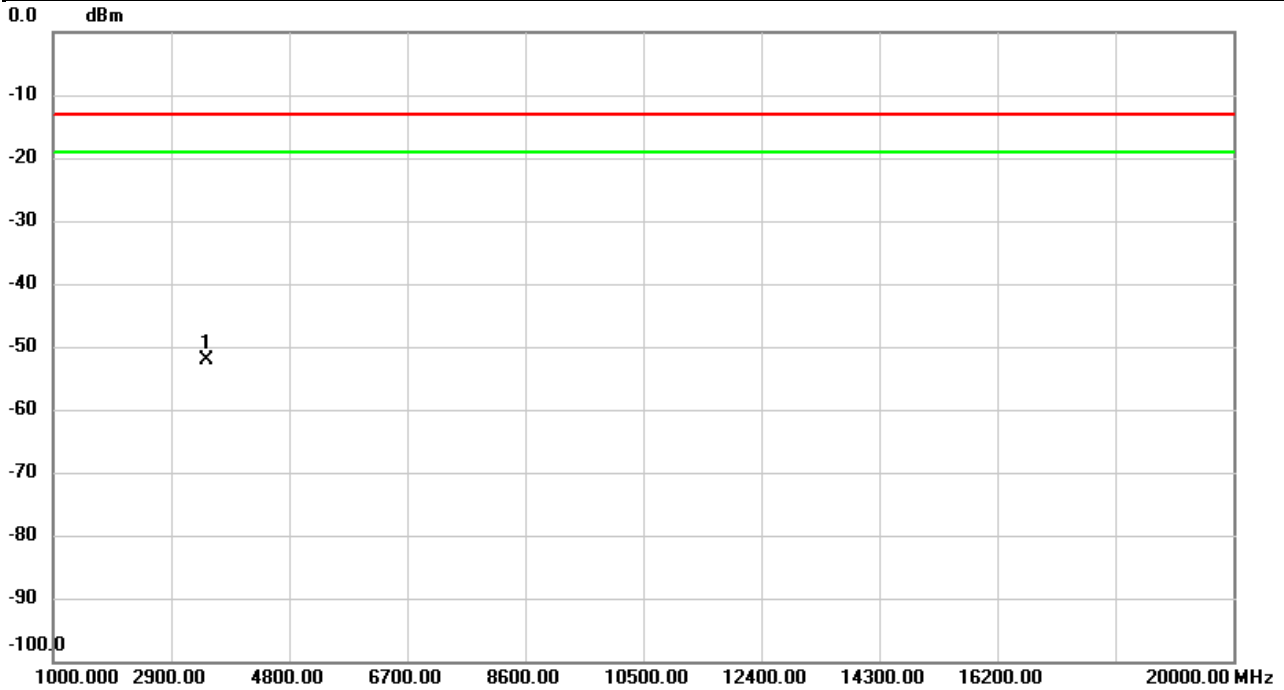

No.	Mk.	Freq.	Reading Level	Correct Factor	Measurement	Limit	Over	Detector	Comment
		MHz	dBm	dB	dBm	dBm	dB		
1	*	3470.000	-50.37	-1.86	-52.23	-13.00	-39.23	peak	

REMARKS:

- (1) Measurement Value = Reading Level + Correct Factor.
- (2) Margin Level = Measurement Value - Limit Value.

Test Mode	LTE Band4	Test Date	2020/10/26
Test Channel	CH20175	Polarization	Vertical
Temp	22°C	Hum.	66%

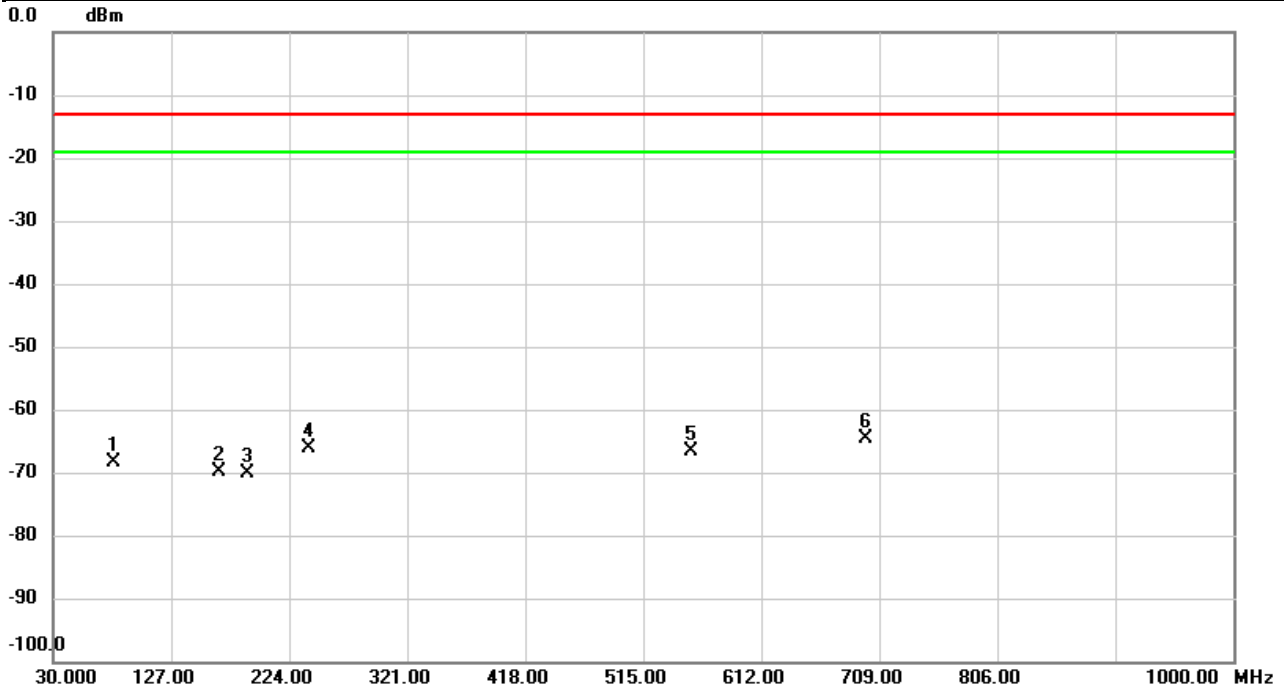

No.	Mk.	Freq. MHz	Reading Level dBm	Correct Factor dB	Measure- ment dBm	Limit dBm	Over dB	Detector	Comment
1		79.4700	-66.29	-2.15	-68.44	-13.00	-55.44	peak	
2		165.8000	-73.18	3.33	-69.85	-13.00	-56.85	peak	
3		189.0800	-74.17	4.00	-70.17	-13.00	-57.17	peak	
4		240.4900	-73.36	7.35	-66.01	-13.00	-53.01	peak	
5		554.7700	-75.89	9.32	-66.57	-13.00	-53.57	peak	
6	*	697.3600	-77.29	12.66	-64.63	-13.00	-51.63	peak	

**REMARKS:**

- (1) Measurement Value = Reading Level + Correct Factor.
- (2) Margin Level = Measurement Value - Limit Value.



Test Mode	LTE Band4	Test Date	2020/10/26
Test Channel	CH20175	Polarization	Horizontal
Temp	22°C	Hum.	66%

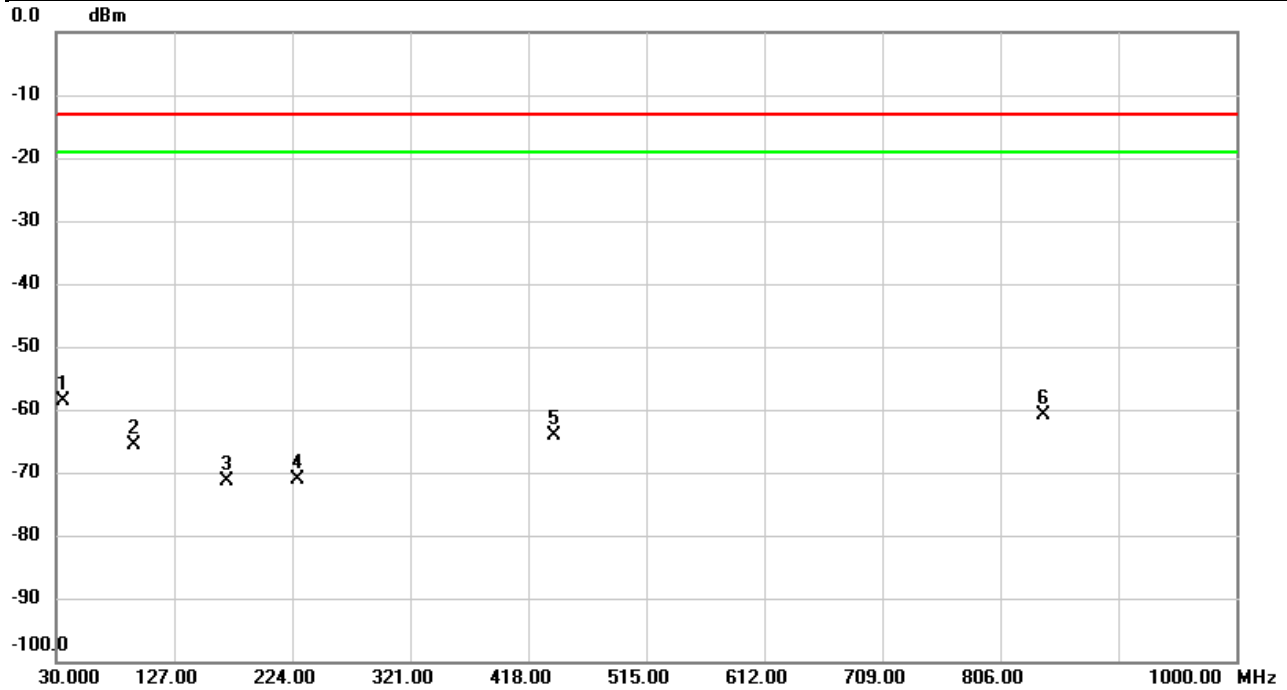

No.	Mk.	Freq. MHz	Reading Level dBm	Correct Factor dB	Measure- ment dBm	Limit dBm	Over dB	Detector	Comment
1	*	35.8200	-73.79	15.22	-58.57	-13.00	-45.57	peak	
2		94.0200	-69.09	3.54	-65.55	-13.00	-52.55	peak	
3		170.6500	-73.43	2.12	-71.31	-13.00	-58.31	peak	
4		228.8500	-70.65	-0.54	-71.19	-13.00	-58.19	peak	
5		439.3400	-75.17	11.03	-64.14	-13.00	-51.14	peak	
6		840.9200	-77.14	16.20	-60.94	-13.00	-47.94	peak	

**REMARKS:**

- (1) Measurement Value = Reading Level + Correct Factor.
- (2) Margin Level = Measurement Value - Limit Value.

Test Mode	LTE Band4	Test Date	2020/10/23
Test Channel	CH20050	Polarization	Vertical
Temp	22°C	Hum.	68%

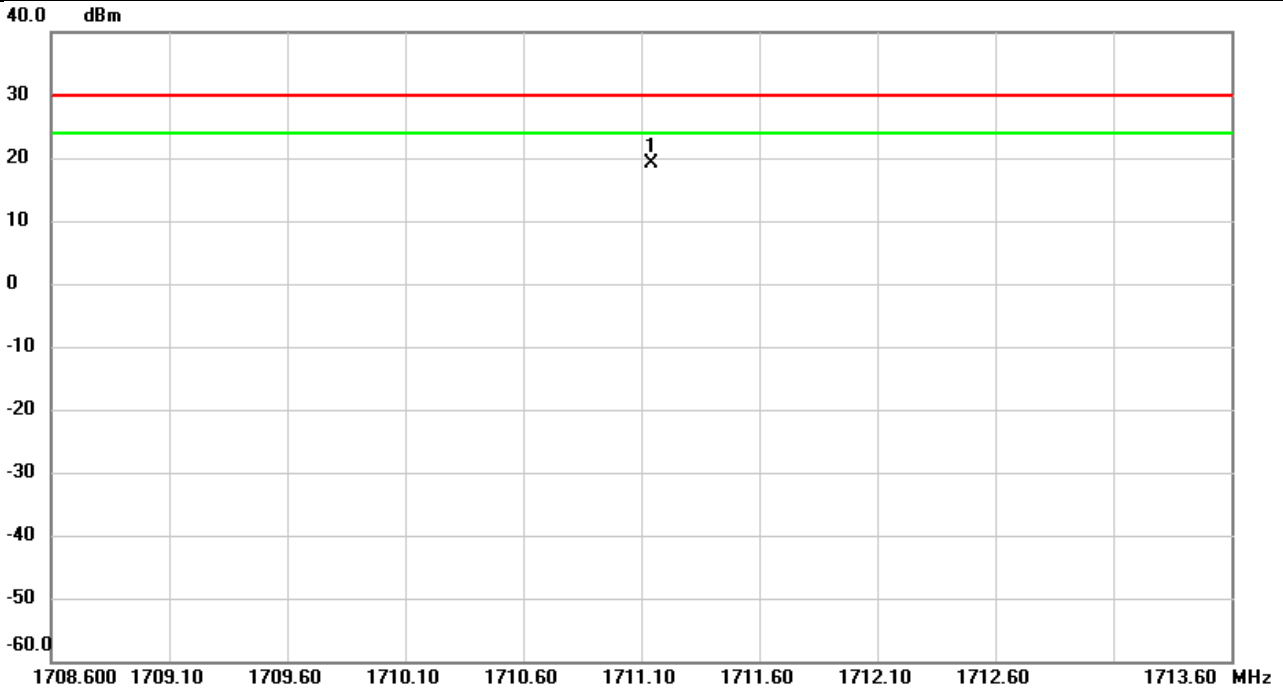

No.	Mk.	Freq.	Reading Level	Correct Factor	Measurement	Limit	Over	Detector	Comment
		MHz	dBm	dB	dBm	dBm	dB		
1	*	1711.145	-20.23	39.47	19.24	30.00	-10.76	peak	

REMARKS:

- (1) Measurement Value = Reading Level + Correct Factor.
- (2) Margin Level = Measurement Value - Limit Value.

Test Mode	LTE Band4	Test Date	2020/10/23
Test Channel	CH20050	Polarization	Horizontal
Temp	22°C	Hum.	68%

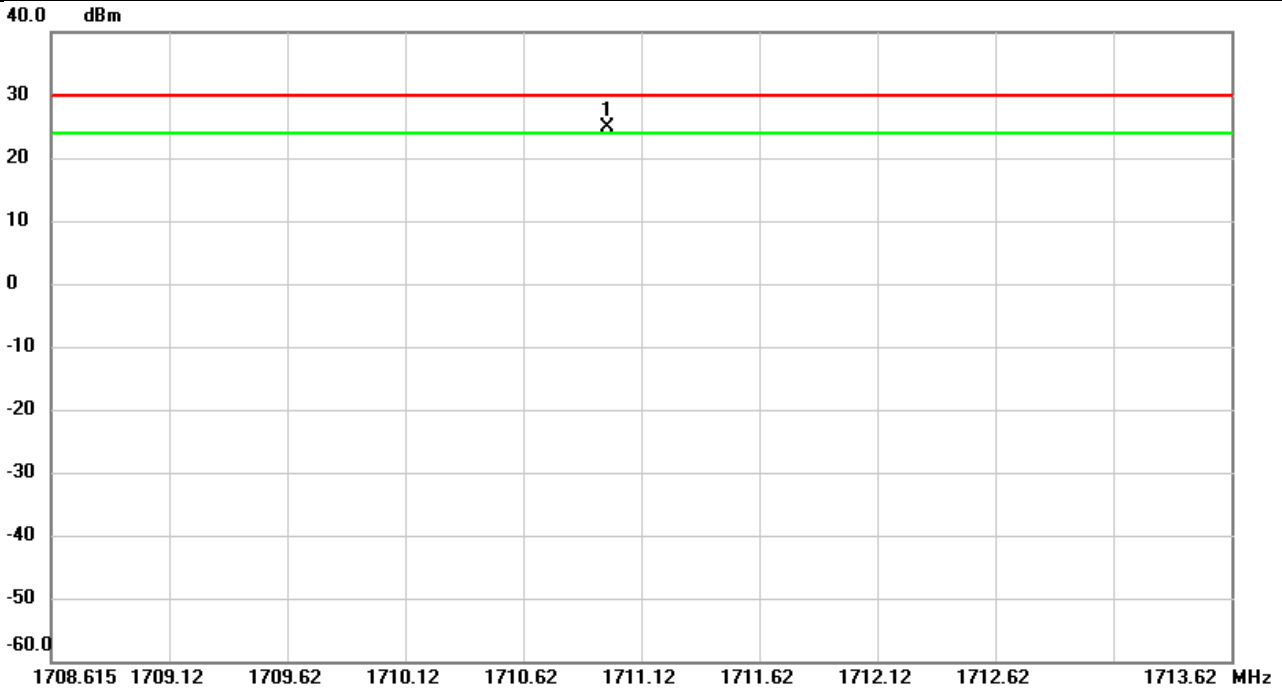

No.	Mk.	Freq.	Reading Level	Correct Factor	Measurement	Limit	Over	Detector	Comment
		MHz	dBm	dB	dBm	dBm	dB		
1	*	1710.970	-15.17	40.11	24.94	30.00	-5.06	peak	

**REMARKS:**

- (1) Measurement Value = Reading Level + Correct Factor.
- (2) Margin Level = Measurement Value - Limit Value.

Test Mode	LTE Band4	Test Date	2020/10/23
Test Channel	CH20175	Polarization	Vertical
Temp	22°C	Hum.	68%

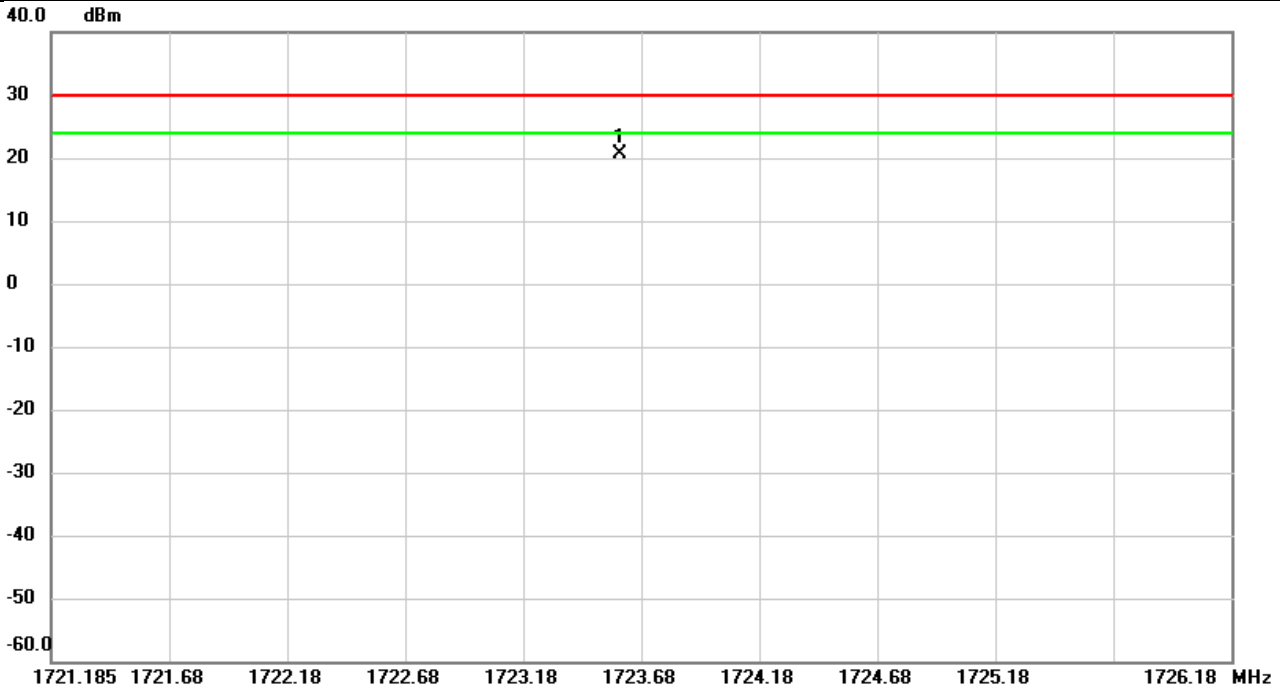

No.	Mk.	Freq.	Reading Level	Correct Factor	Measurement	Limit	Over	Detector	Comment
		MHz	dBm	dB	dBm	dBm	dB		
1	*	1723.595	-18.79	39.53	20.74	30.00	-9.26	peak	

**REMARKS:**

- (1) Measurement Value = Reading Level + Correct Factor.
- (2) Margin Level = Measurement Value - Limit Value.

Test Mode	LTE Band4	Test Date	2020/10/23
Test Channel	CH20175	Polarization	Horizontal
Temp	22°C	Hum.	68%

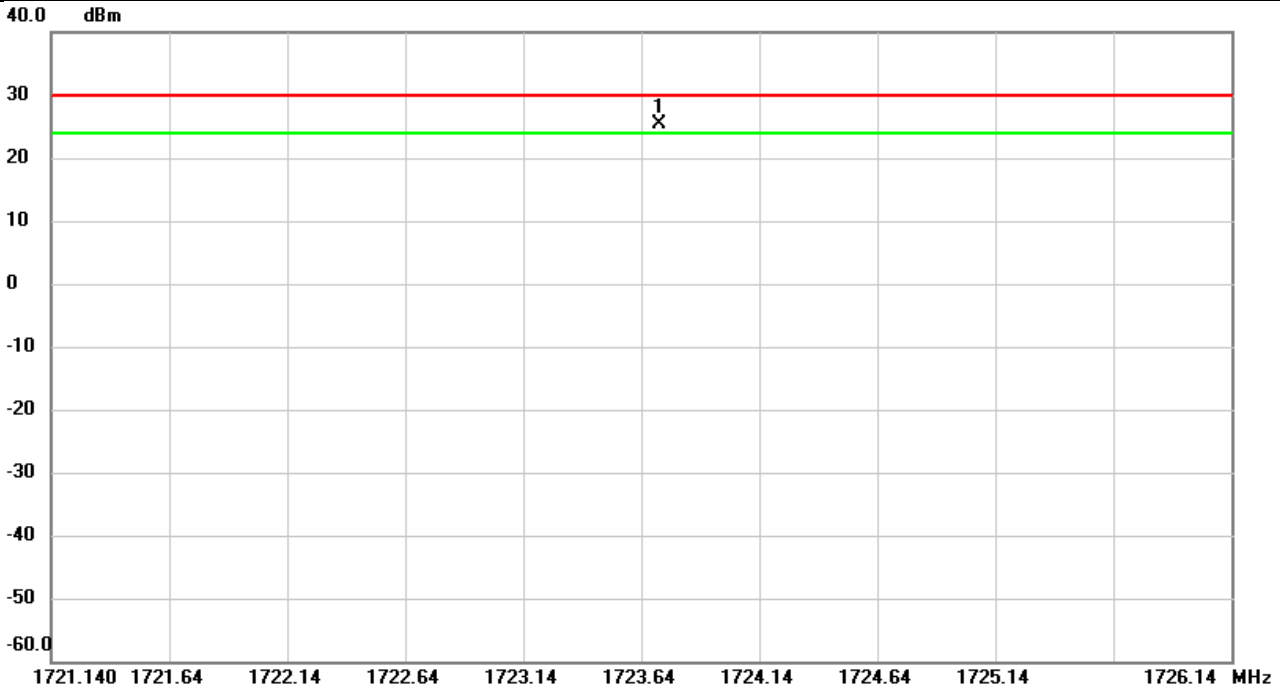

No.	Mk.	Freq.	Reading Level	Correct Factor	Measurement	Limit	Over	Detector	Comment
		MHz	dBm	dB	dBm	dBm	dB		
1	*	1723.715	-14.74	40.15	25.41	30.00	-4.59	peak	

REMARKS:

- (1) Measurement Value = Reading Level + Correct Factor.
- (2) Margin Level = Measurement Value - Limit Value.

Test Mode	LTE Band4	Test Date	2020/10/23
Test Channel	CH20300	Polarization	Vertical
Temp	22°C	Hum.	68%

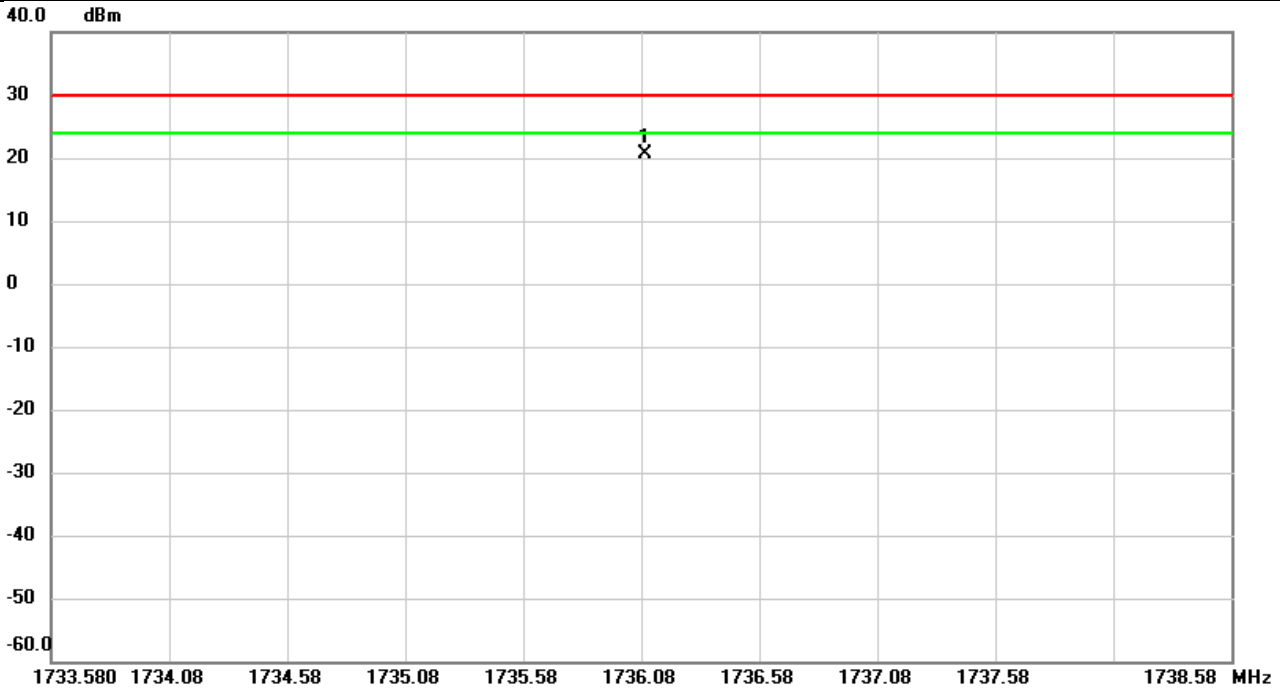

No.	Mk.	Freq.	Reading Level	Correct Factor	Measurement	Limit	Over	Detector	Comment
		MHz	dBm	dB	dBm	dBm	dB		
1	*	1736.100	-18.83	39.58	20.75	30.00	-9.25	peak	

REMARKS:

- (1) Measurement Value = Reading Level + Correct Factor.
- (2) Margin Level = Measurement Value - Limit Value.

Test Mode	LTE Band4	Test Date	2020/10/23
Test Channel	CH20300	Polarization	Horizontal
Temp	22°C	Hum.	68%

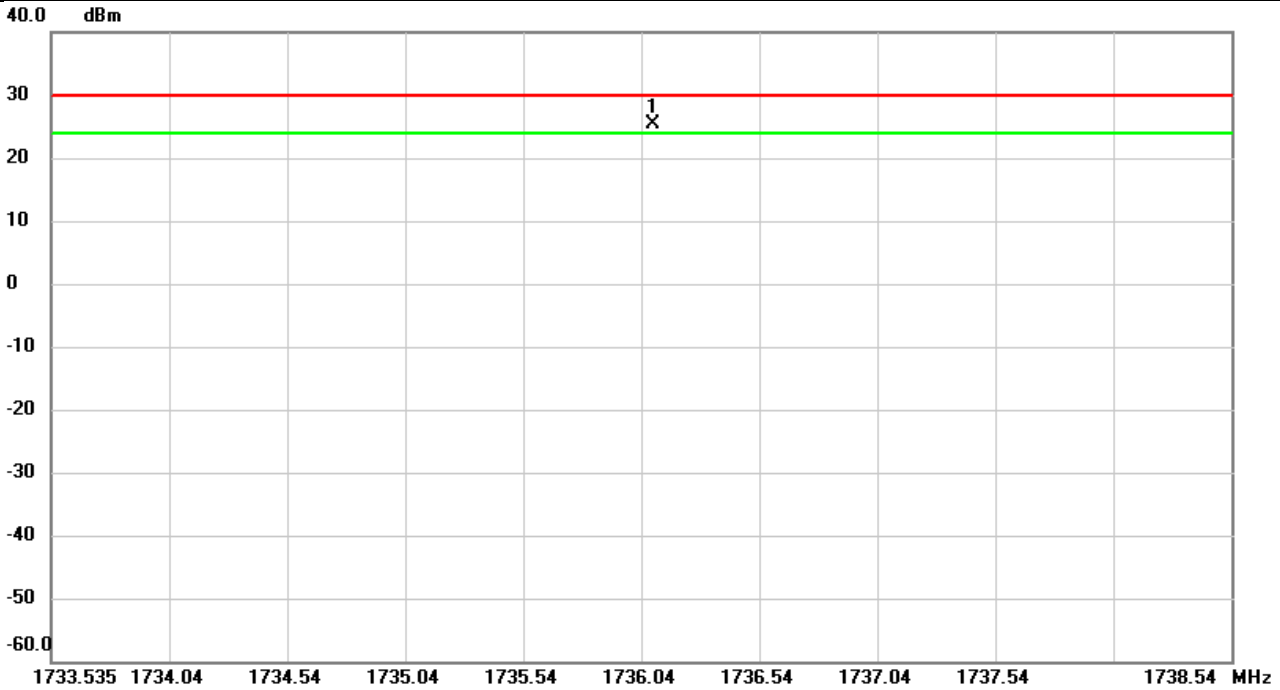

No.	Mk.	Freq.	Reading Level	Correct Factor	Measurement	Limit	Over	Detector	Comment
		MHz	dBm	dB	dBm	dBm	dB		
1	*	1736.085	-14.74	40.20	25.46	30.00	-4.54	peak	

REMARKS:

- (1) Measurement Value = Reading Level + Correct Factor.
- (2) Margin Level = Measurement Value - Limit Value.

Test Mode	LTE Band4	Test Date	2020/10/27
Test Channel	CH20175	Polarization	Vertical
Temp	22°C	Hum.	66%

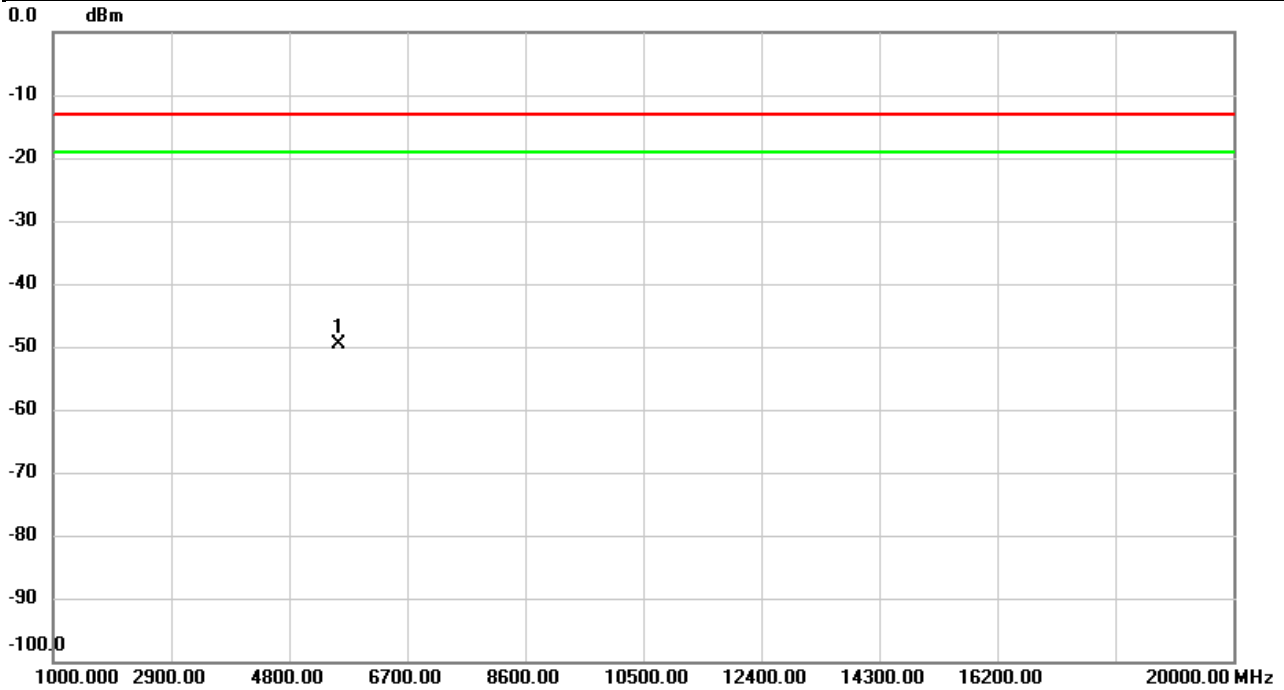

No.	Mk.	Freq.	Reading Level	Correct Factor	Measurement	Limit	Over	Detector	Comment
		MHz	dBm	dB	dBm	dBm	dB		
1	*	5598.000	-52.05	2.46	-49.59	-13.00	-36.59	peak	

REMARKS:

- (1) Measurement Value = Reading Level + Correct Factor.
- (2) Margin Level = Measurement Value - Limit Value.



Test Mode	LTE Band4	Test Date	2020/10/27
Test Channel	CH20175	Polarization	Horizontal
Temp	22°C	Hum.	66%

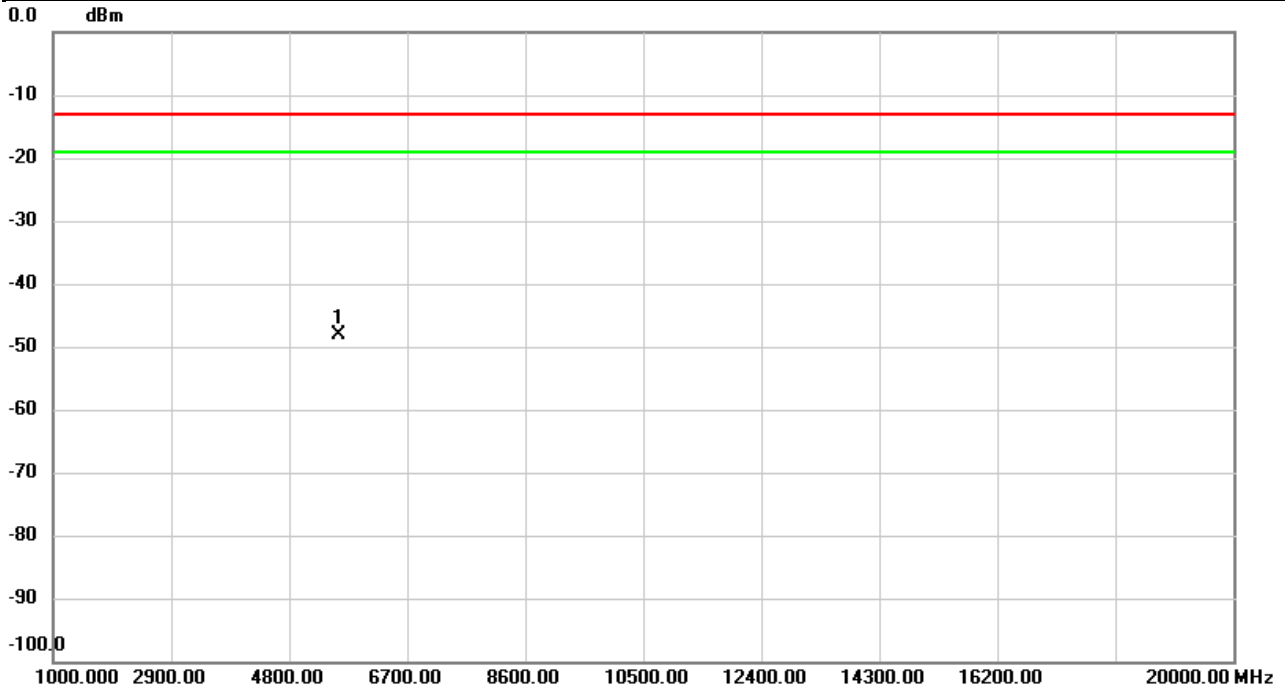

No.	Mk.	Freq.	Reading Level	Correct Factor	Measurement	Limit	Over	Detector	Comment
		MHz	dBm	dB	dBm	dBm	dB		
1	*	5598.000	-50.87	2.85	-48.02	-13.00	-35.02	peak	

REMARKS:

- (1) Measurement Value = Reading Level + Correct Factor.
- (2) Margin Level = Measurement Value - Limit Value.

Test Mode	LTE Band7	Test Date	2020/10/26
Test Channel	CH21100	Polarization	Vertical
Temp	22°C	Hum.	66%

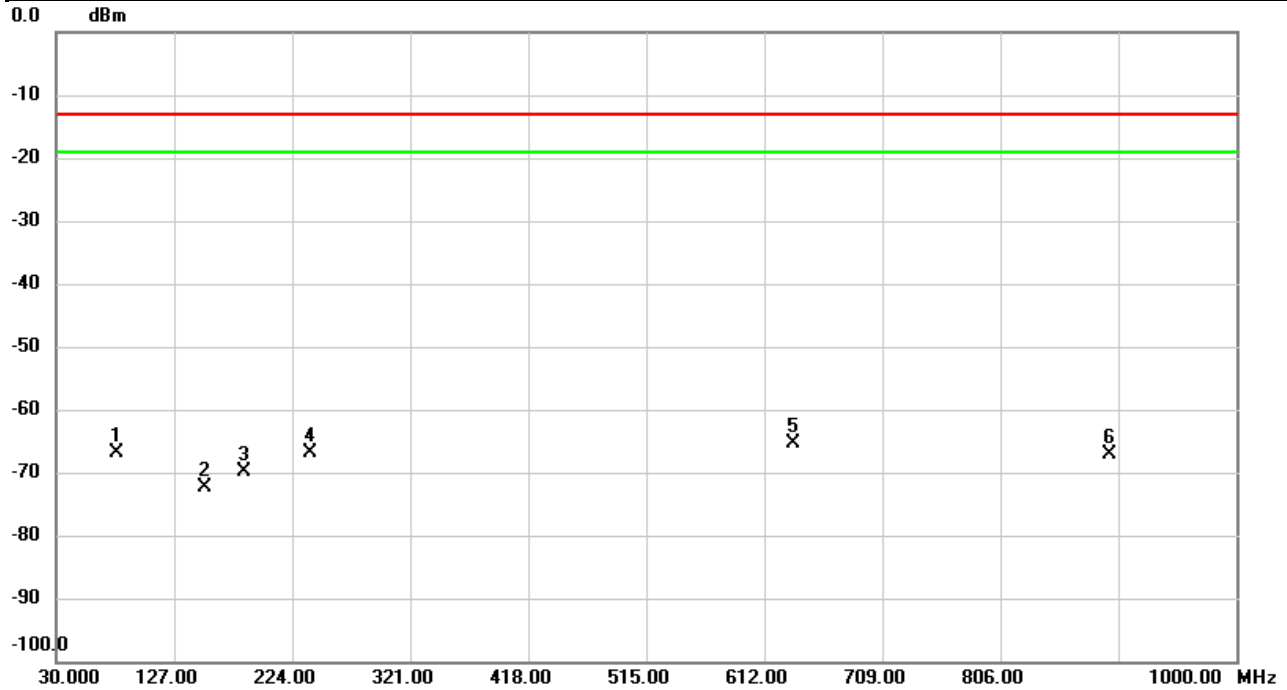

No.	Mk.	Freq. MHz	Reading Level dBm	Correct Factor dB	Measure- ment dBm	Limit dBm	Over dB	Detector	Comment
1		79.4700	-64.65	-2.15	-66.80	-13.00	-53.80	peak	
2		152.2200	-75.47	3.22	-72.25	-13.00	-59.25	peak	
3		184.2300	-73.92	3.93	-69.99	-13.00	-56.99	peak	
4		238.5500	-73.57	6.81	-66.76	-13.00	-53.76	peak	
5	*	635.2800	-78.00	12.54	-65.46	-13.00	-52.46	peak	
6		896.2100	-77.84	10.74	-67.10	-13.00	-54.10	peak	

**REMARKS:**

- (1) Measurement Value = Reading Level + Correct Factor.
- (2) Margin Level = Measurement Value - Limit Value.

Test Mode	LTE Band7	Test Date	2020/10/26
Test Channel	CH21100	Polarization	Horizontal
Temp	22°C	Hum.	66%

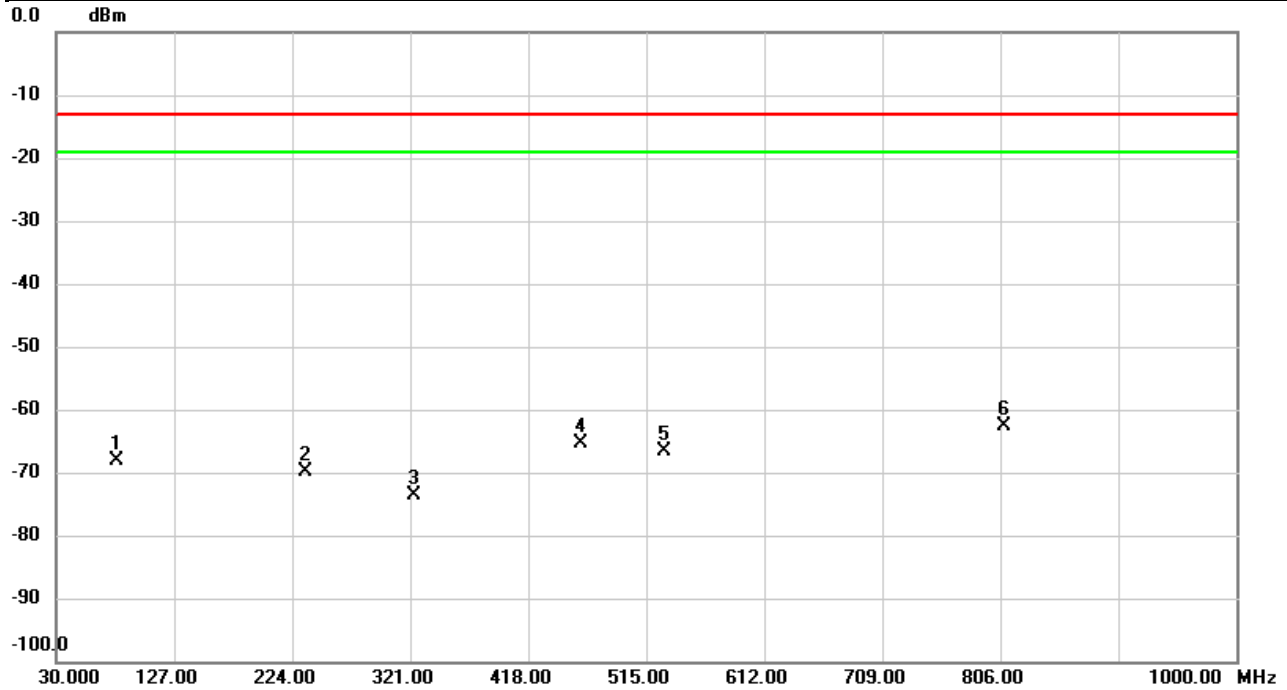

No.	Mk.	Freq. MHz	Reading Level dBm	Correct Factor dB	Measure- ment dBm	Limit dBm	Over dB	Detector	Comment
1		79.4700	-73.67	5.67	-68.00	-13.00	-55.00	peak	
2		234.6700	-69.34	-0.46	-69.80	-13.00	-56.80	peak	
3		323.9100	-75.97	2.40	-73.57	-13.00	-60.57	peak	
4		460.6800	-77.70	12.44	-65.26	-13.00	-52.26	peak	
5		529.5500	-76.23	9.60	-66.63	-13.00	-53.63	peak	
6	*	808.9100	-78.12	15.41	-62.71	-13.00	-49.71	peak	

**REMARKS:**

- (1) Measurement Value = Reading Level + Correct Factor.
- (2) Margin Level = Measurement Value - Limit Value.

Test Mode	LTE Band7	Test Date	2020/10/23
Test Channel	CH20850	Polarization	Vertical
Temp	22°C	Hum.	68%

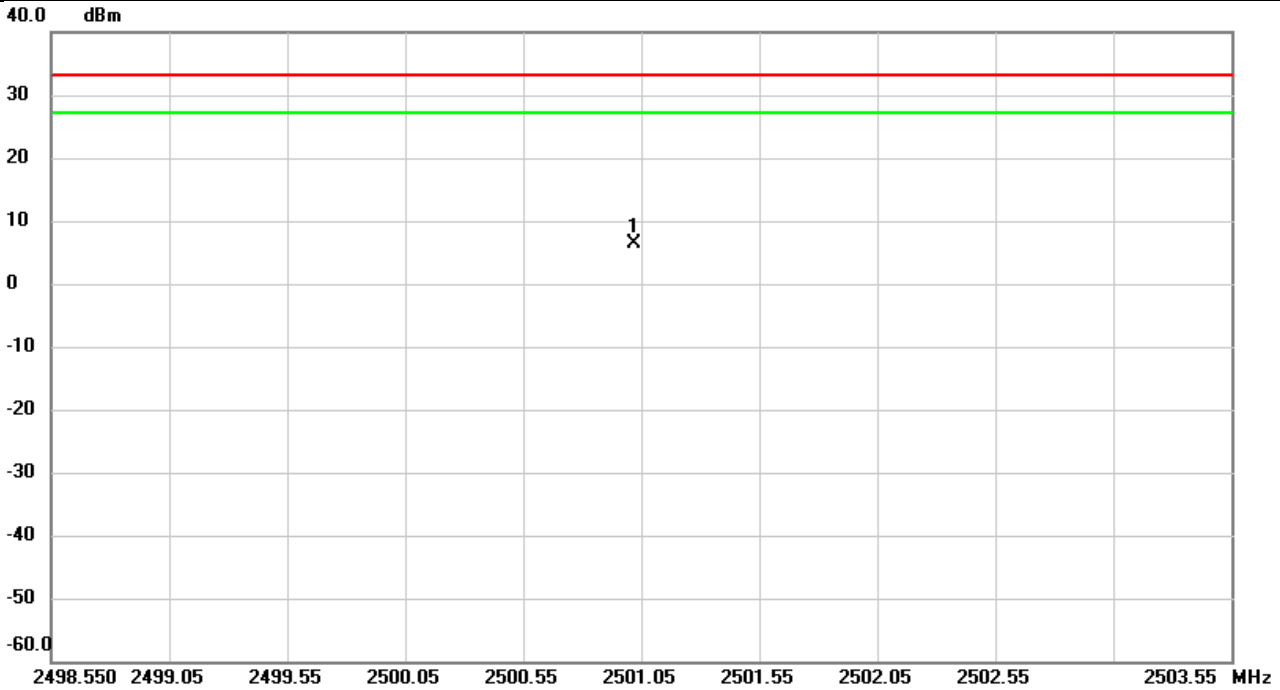

No.	Mk.	Freq.	Reading Level	Correct Factor	Measurement	Limit	Over	Detector	Comment
		MHz	dBm	dB	dBm	dBm	dB		
1	*	2501.020	-35.61	42.09	6.48	33.01	-26.53	peak	

REMARKS:

- (1) Measurement Value = Reading Level + Correct Factor.
- (2) Margin Level = Measurement Value - Limit Value.

Test Mode	LTE Band7	Test Date	2020/10/23
Test Channel	CH20850	Polarization	Horizontal
Temp	22°C	Hum.	68%

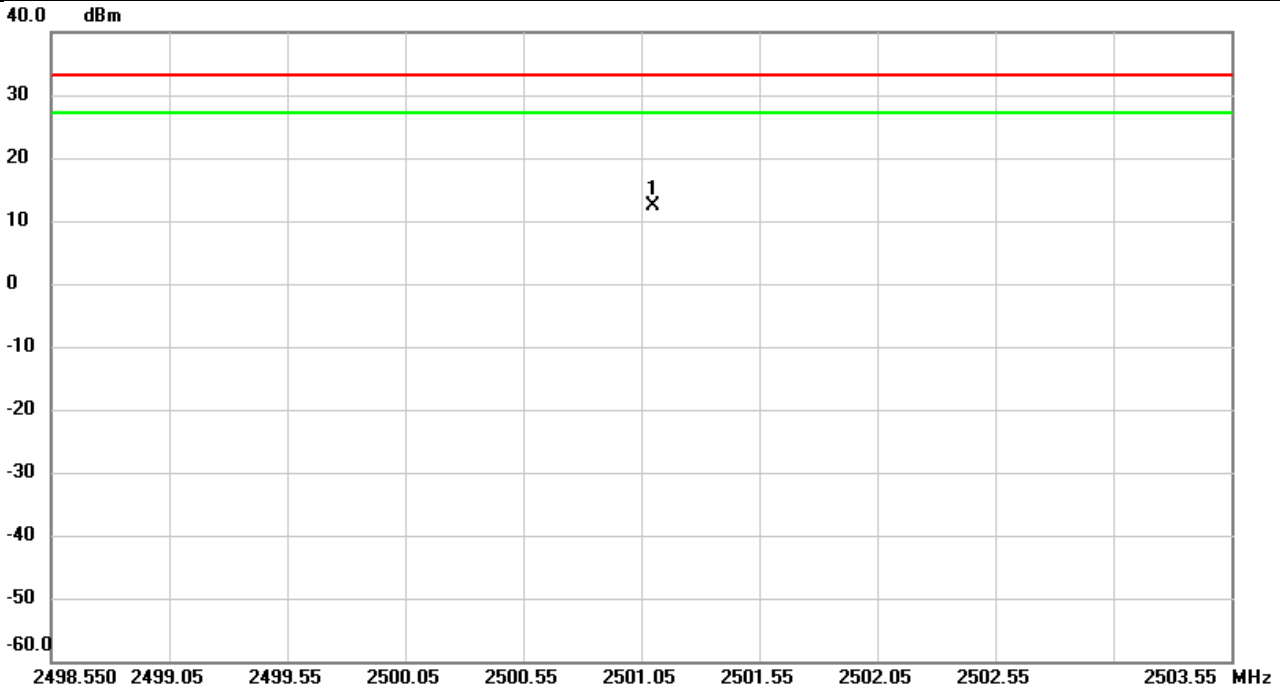

No.	Mk.	Freq. MHz	Reading Level dBm	Correct Factor dB	Measure- ment dBm	Limit dBm	Over dB	Detector	Comment
1	*	2501.100	-29.50	41.83	12.33	33.01	-20.68	peak	

REMARKS:

- (1) Measurement Value = Reading Level + Correct Factor.
- (2) Margin Level = Measurement Value - Limit Value.

Test Mode	LTE Band7	Test Date	2020/10/23
Test Channel	CH21100	Polarization	Vertical
Temp	22°C	Hum.	68%

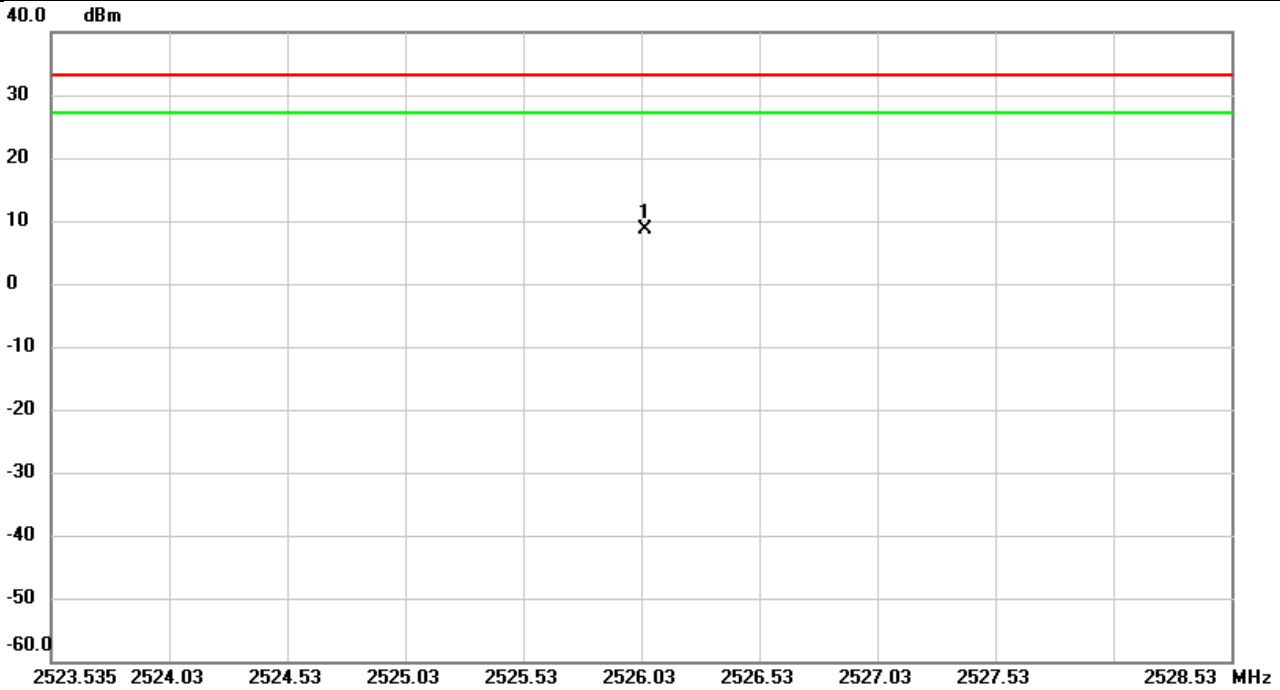

No.	Mk.	Freq.	Reading Level	Correct Factor	Measurement	Limit	Over	Detector	Comment
		MHz	dBm	dB	dBm	dBm	dB		
1	*	2526.050	-33.43	42.10	8.67	33.01	-24.34	peak	

REMARKS:

- (1) Measurement Value = Reading Level + Correct Factor.
- (2) Margin Level = Measurement Value - Limit Value.

Test Mode	LTE Band7	Test Date	2020/10/23
Test Channel	CH21100	Polarization	Horizontal
Temp	22°C	Hum.	68%

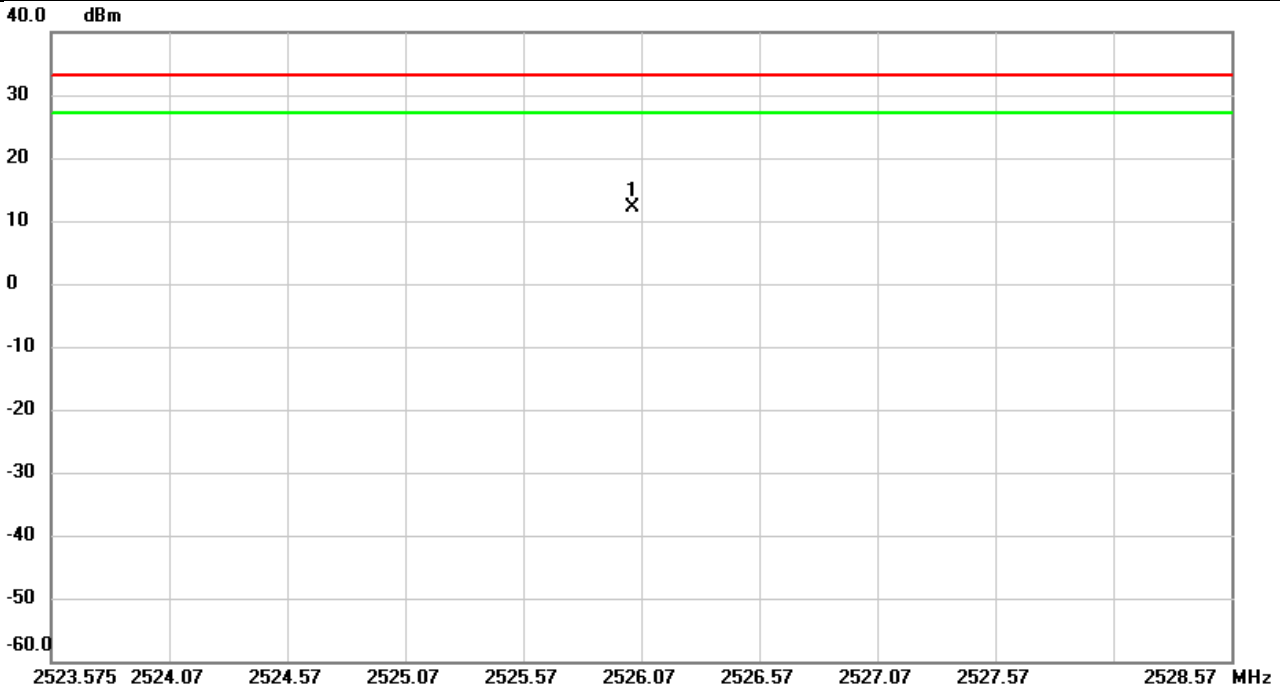

No.	Mk.	Freq. MHz	Reading Level dBm	Correct Factor dB	Measure- ment dBm	Limit dBm	Over dB	Detector	Comment
1	*	2526.035	-29.82	41.94	12.12	33.01	-20.89	peak	

**REMARKS:**

- (1) Measurement Value = Reading Level + Correct Factor.
- (2) Margin Level = Measurement Value - Limit Value.

Test Mode	LTE Band7	Test Date	2020/10/23
Test Channel	CH21350	Polarization	Vertical
Temp	22°C	Hum.	68%

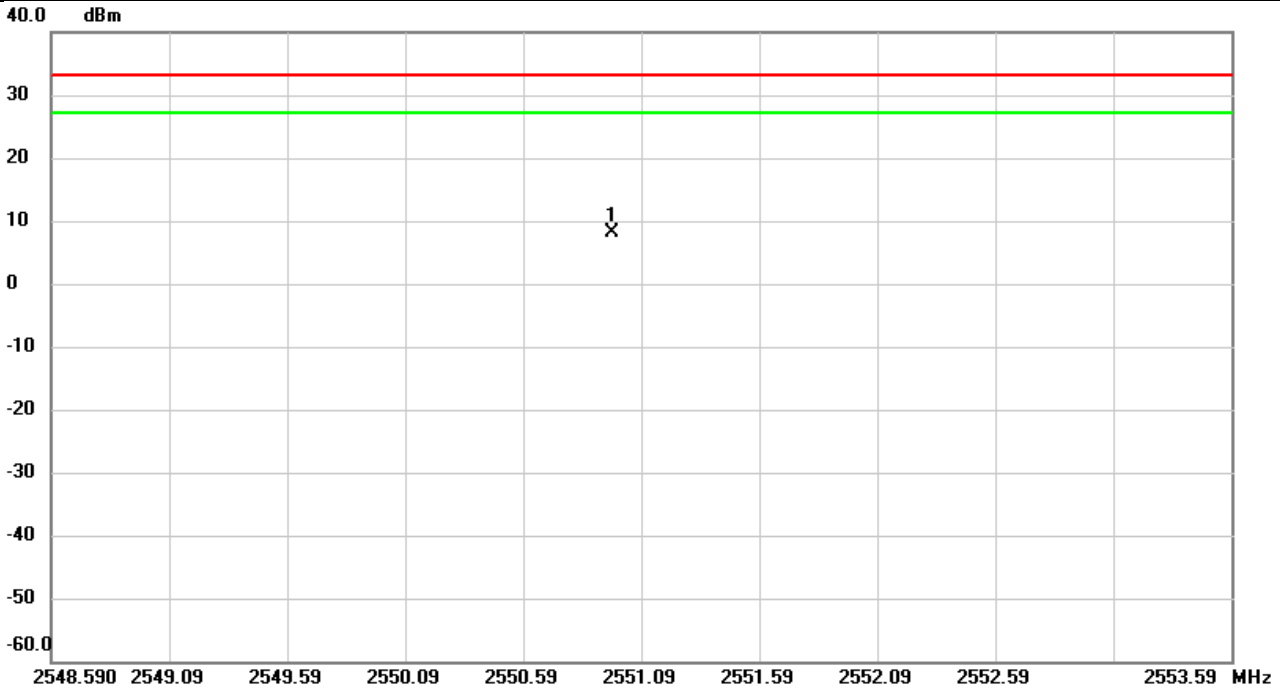

No.	Mk.	Freq.	Reading Level	Correct Factor	Measurement	Limit	Over	Detector	Comment
		MHz	dBm	dB	dBm	dBm	dB		
1	*	2550.965	-34.07	42.12	8.05	33.01	-24.96	peak	

REMARKS:

- (1) Measurement Value = Reading Level + Correct Factor.
- (2) Margin Level = Measurement Value - Limit Value.



Test Mode	LTE Band7	Test Date	2020/10/23
Test Channel	CH21350	Polarization	Horizontal
Temp	22°C	Hum.	68%

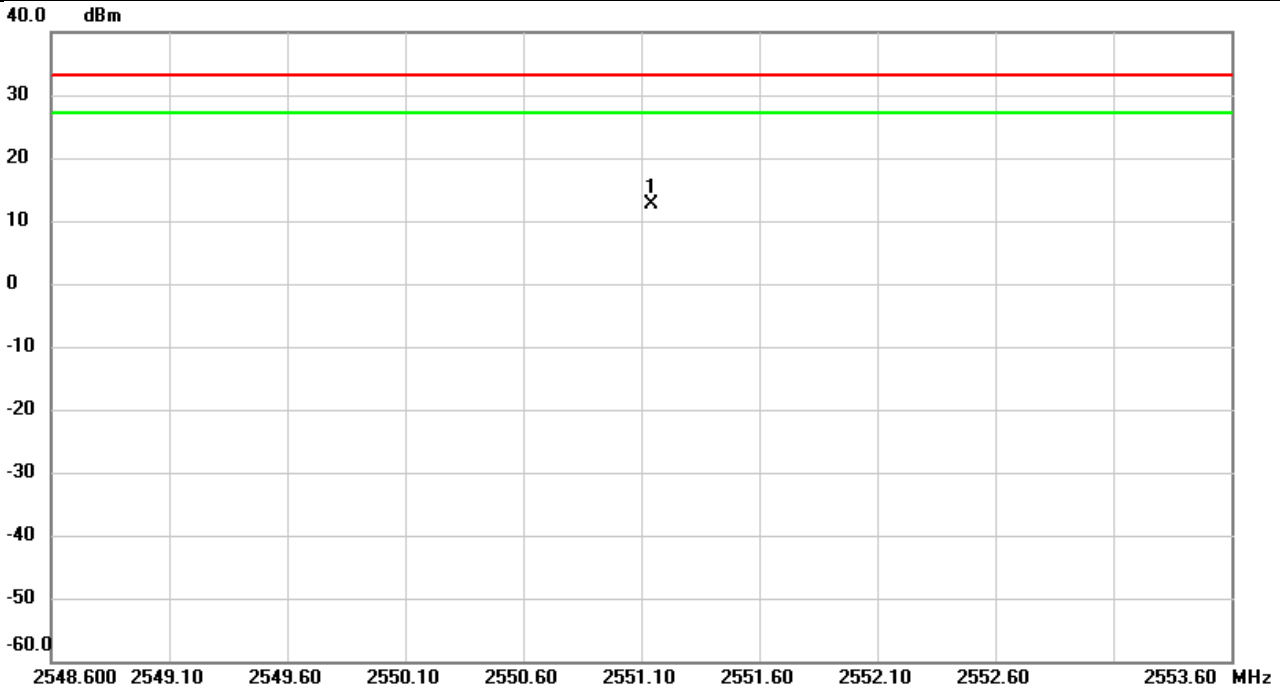

No.	Mk.	Freq.	Reading Level	Correct Factor	Measurement	Limit	Over	Detector	Comment
		MHz	dBm	dB	dBm	dBm	dB		
1	*	2551.145	-29.42	42.06	12.64	33.01	-20.37	peak	

**REMARKS:**

- (1) Measurement Value = Reading Level + Correct Factor.
- (2) Margin Level = Measurement Value - Limit Value.

Test Mode	LTE Band7	Test Date	2020/10/27
Test Channel	CH21100	Polarization	Vertical
Temp	22°C	Hum.	66%

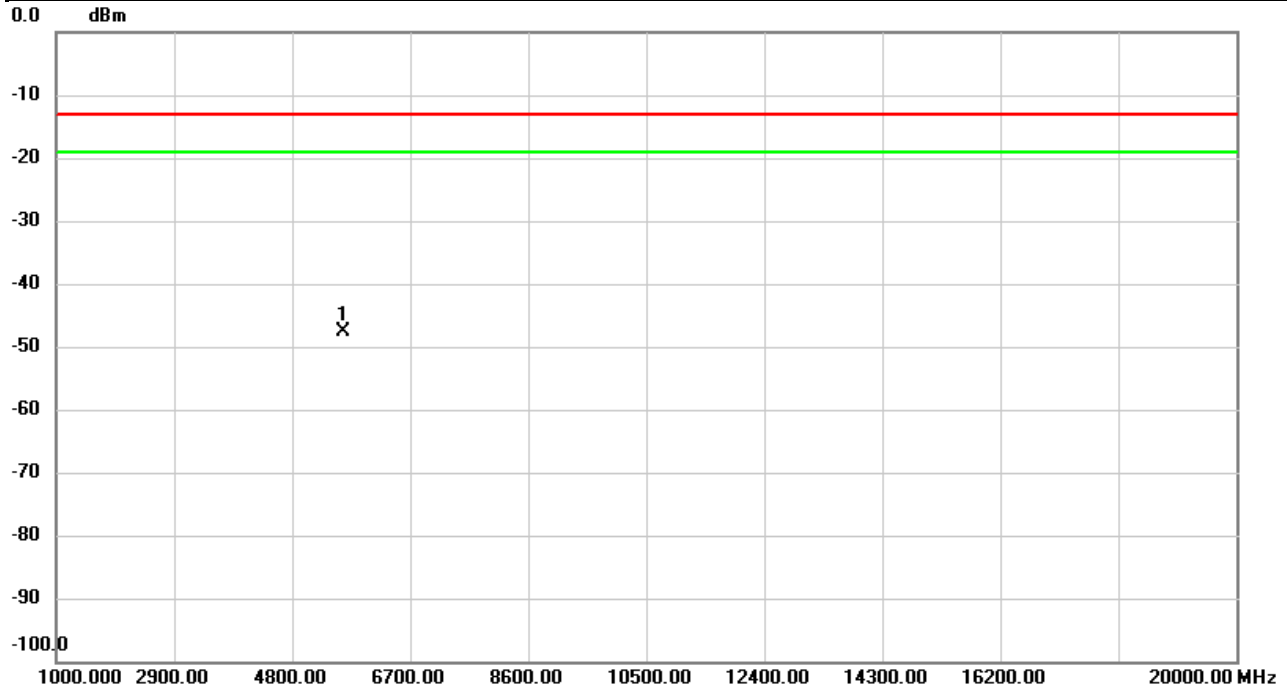

No.	Mk.	Freq.	Reading Level	Correct Factor	Measurement	Limit	Over	Detector	Comment
		MHz	dBm	dB	dBm	dBm	dB		
1	*	5617.000	-50.04	2.43	-47.61	-13.00	-34.61	peak	

REMARKS:  
 (1) Measurement Value = Reading Level + Correct Factor.  
 (2) Margin Level = Measurement Value - Limit Value.

Test Mode	LTE Band7	Test Date	2020/10/27
Test Channel	CH21100	Polarization	Horizontal
Temp	22°C	Hum.	66%

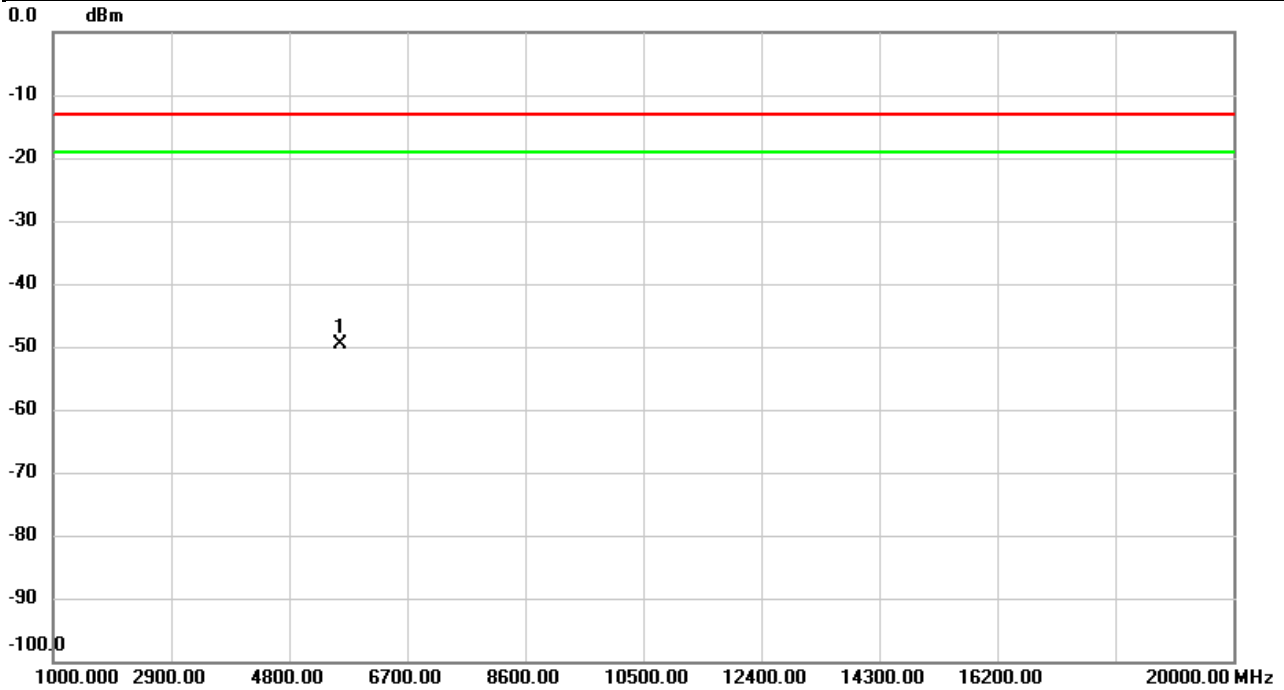

No.	Mk.	Freq.	Reading Level	Correct Factor	Measurement	Limit	Over	Detector	Comment
		MHz	dBm	dB	dBm	dBm	dB		
1	*	5617.000	-52.39	2.81	-49.58	-13.00	-36.58	peak	

REMARKS:

- (1) Measurement Value = Reading Level + Correct Factor.
- (2) Margin Level = Measurement Value - Limit Value.

Test Mode	LTE Band12	Test Date	2020/10/26
Test Channel	CH23095	Polarization	Vertical
Temp	22°C	Hum.	66%

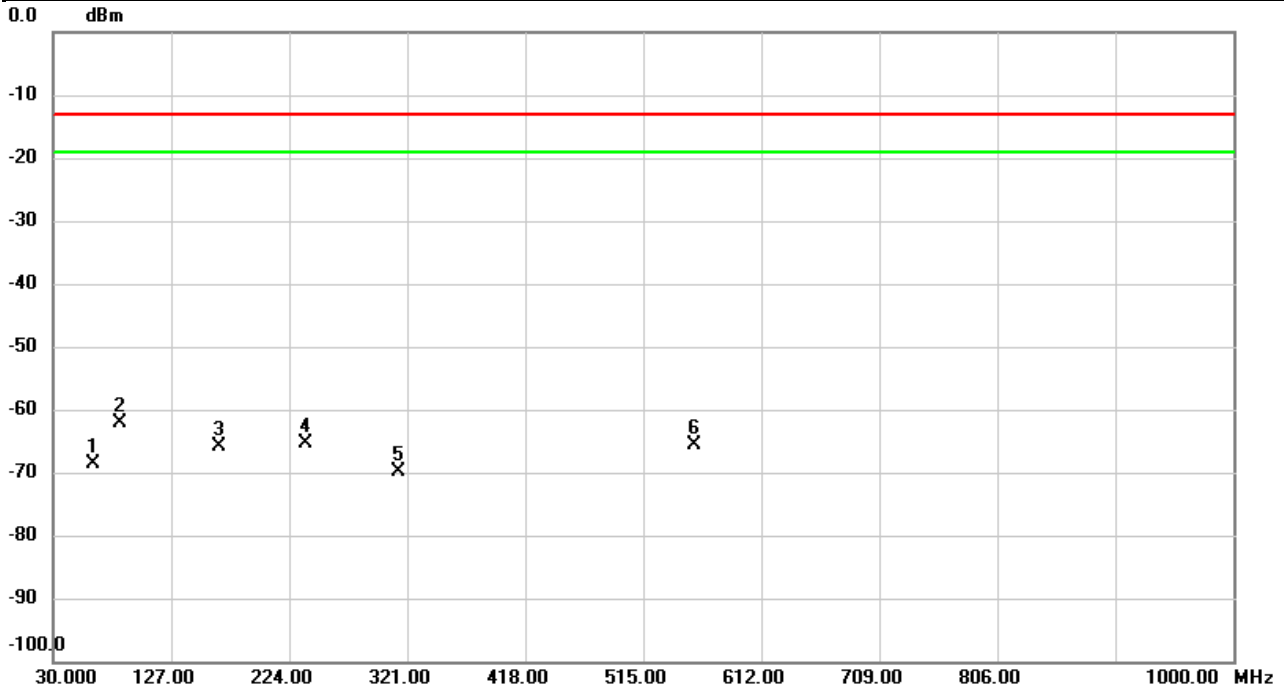

No.	Mk.	Freq.	Reading Level	Correct Factor	Measurement	Limit	Over	Detector	Comment
		MHz	dBm	dB	dBm	dBm	dB		
1		62.9800	-67.07	-1.65	-68.72	-13.00	-55.72	peak	
2	*	84.3200	-60.28	-1.89	-62.17	-13.00	-49.17	peak	
3		165.8000	-69.26	3.33	-65.93	-13.00	-52.93	peak	
4		237.5800	-71.89	6.46	-65.43	-13.00	-52.43	peak	
5		313.2400	-77.21	7.35	-69.86	-13.00	-56.86	peak	
6		557.6800	-75.23	9.50	-65.73	-13.00	-52.73	peak	

**REMARKS:**

- (1) Measurement Value = Reading Level + Correct Factor.
- (2) Margin Level = Measurement Value - Limit Value.

Test Mode	LTE Band12	Test Date	2020/10/26
Test Channel	CH23095	Polarization	Horizontal
Temp	22°C	Hum.	66%

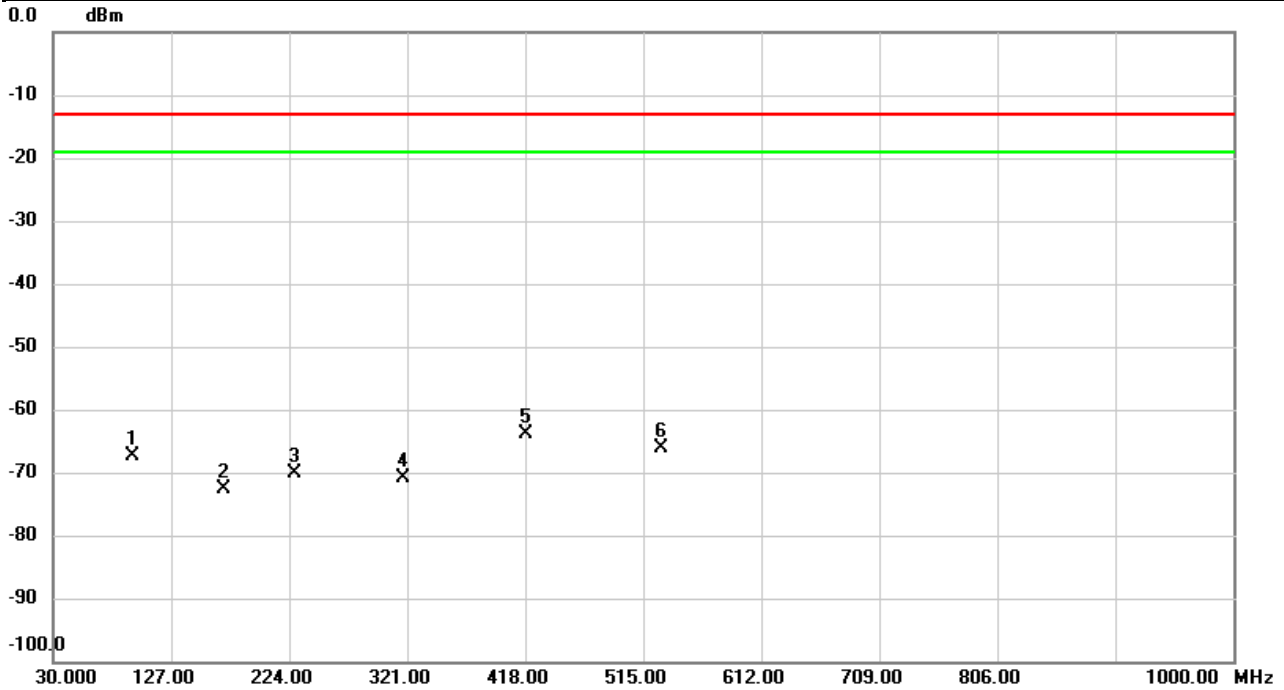

No.	Mk.	Freq.	Reading Level	Correct Factor	Measurement	Limit	Over	Detector	Comment
		MHz	dBm	dB	dBm	dBm	dB		
1		94.9900	-70.87	3.51	-67.36	-13.00	-54.36	peak	
2		169.6800	-74.73	2.18	-72.55	-13.00	-59.55	peak	
3		228.8500	-69.68	-0.54	-70.22	-13.00	-57.22	peak	
4		317.1200	-72.91	1.96	-70.95	-13.00	-57.95	peak	
5	*	418.0000	-72.31	8.40	-63.91	-13.00	-50.91	peak	
6		529.5500	-75.67	9.60	-66.07	-13.00	-53.07	peak	

**REMARKS:**

- (1) Measurement Value = Reading Level + Correct Factor.
- (2) Margin Level = Measurement Value - Limit Value.

Test Mode	LTE Band12	Test Date	2020/10/26
Test Channel	CH23060	Polarization	Vertical
Temp	22°C	Hum.	66%

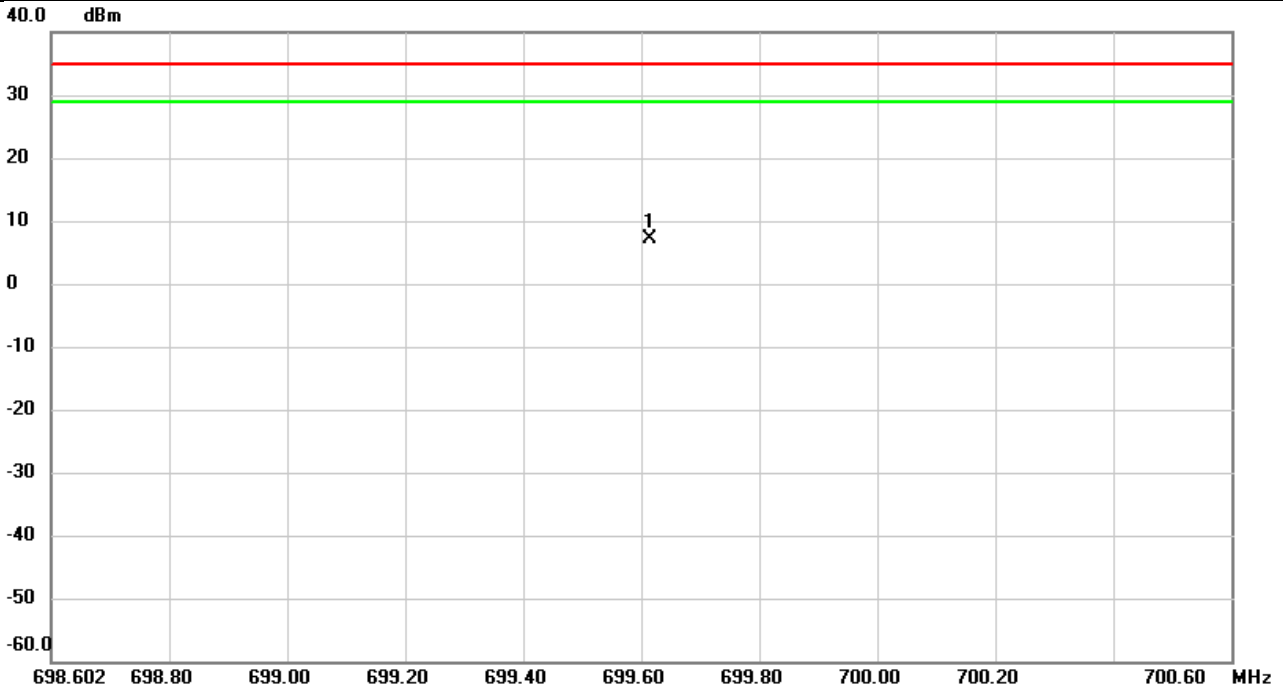

No.	Mk.	Freq.	Reading Level	Correct Factor	Measurement	Limit	Over	Detector	Comment
		MHz	dBm	dB	dBm	dBm	dB		
1	*	699.6160	-25.95	32.96	7.01	34.77	-27.76	peak	

**REMARKS:**

- (1) Measurement Value = Reading Level + Correct Factor.
- (2) Margin Level = Measurement Value - Limit Value.

Test Mode	LTE Band12	Test Date	2020/10/26
Test Channel	CH23060	Polarization	Horizontal
Temp	22°C	Hum.	66%

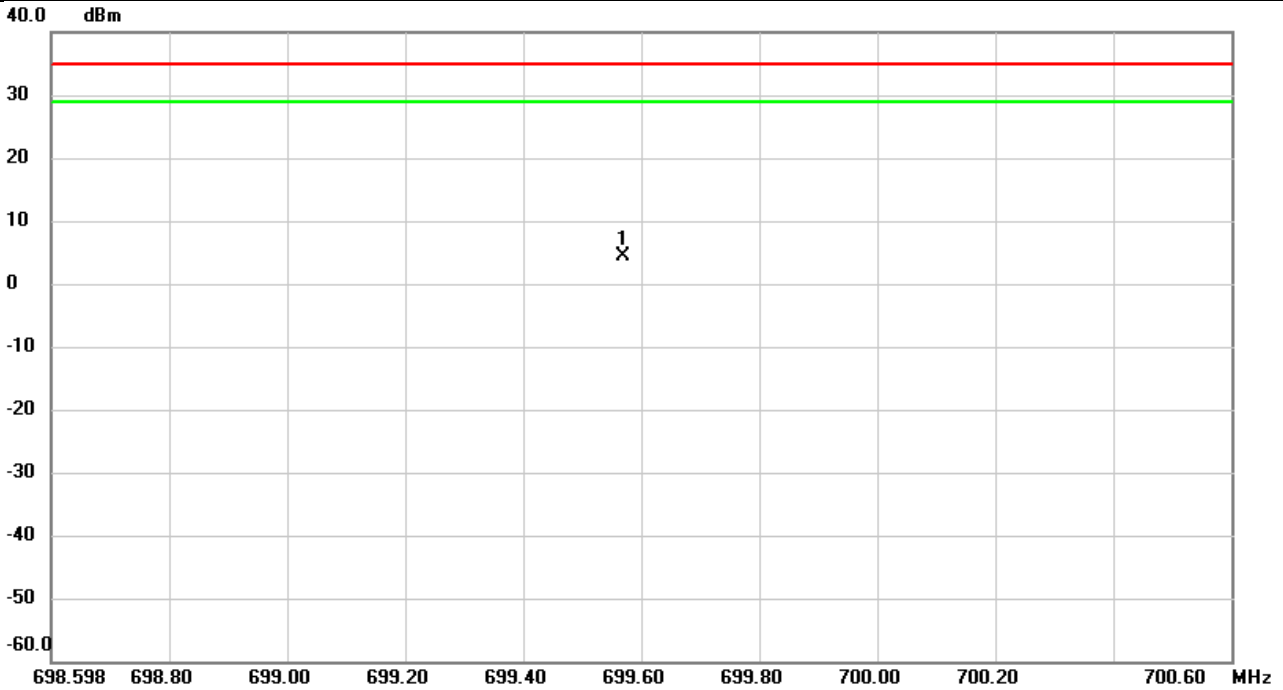

No.	Mk.	Freq.	Reading Level	Correct Factor	Measurement	Limit	Over	Detector	Comment
		MHz	dBm	dB	dBm	dBm	dB		
1	*	699.5660	-26.09	30.44	4.35	34.77	-30.42	peak	

REMARKS:

- (1) Measurement Value = Reading Level + Correct Factor.
- (2) Margin Level = Measurement Value - Limit Value.

Test Mode	LTE Band12	Test Date	2020/10/26
Test Channel	CH23095	Polarization	Vertical
Temp	22°C	Hum.	66%

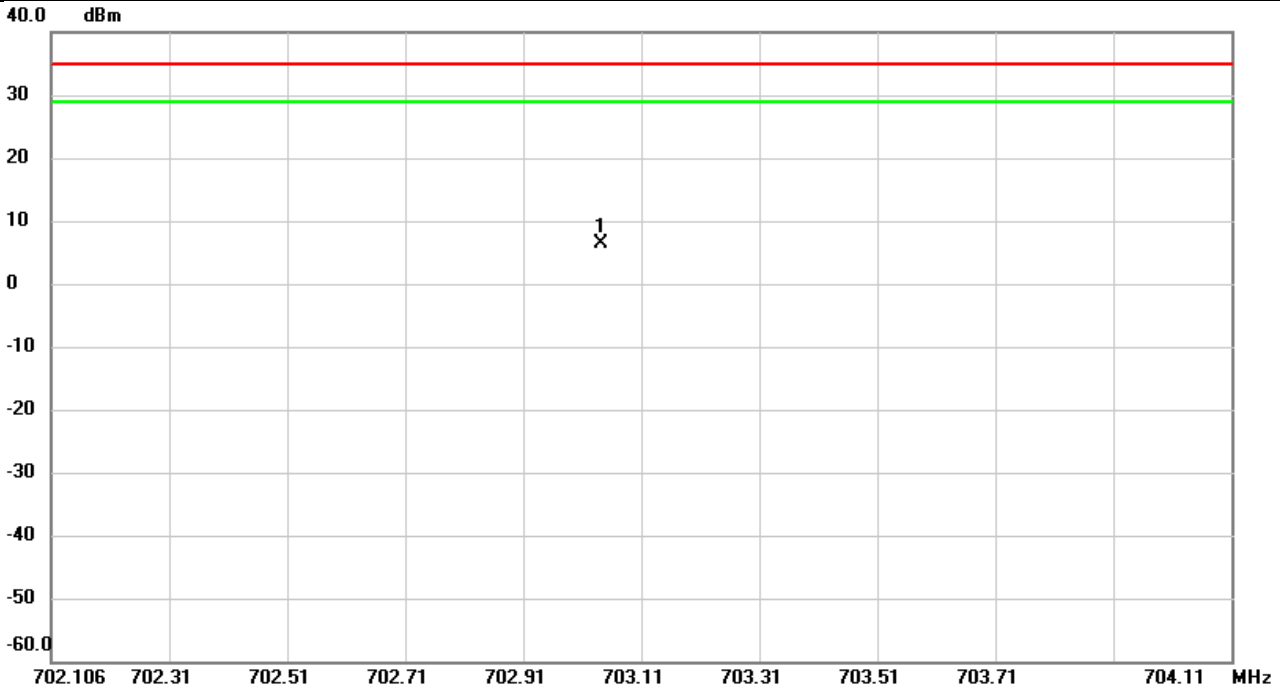

No.	Mk.	Freq.	Reading Level	Correct Factor	Measurement	Limit	Over	Detector	Comment
		MHz	dBm	dB	dBm	dBm	dB		
1	*	703.0380	-26.56	32.99	6.43	34.77	-28.34	peak	

REMARKS:

- (1) Measurement Value = Reading Level + Correct Factor.
- (2) Margin Level = Measurement Value - Limit Value.



Test Mode	LTE Band12	Test Date	2020/10/26
Test Channel	CH23095	Polarization	Horizontal
Temp	22°C	Hum.	66%

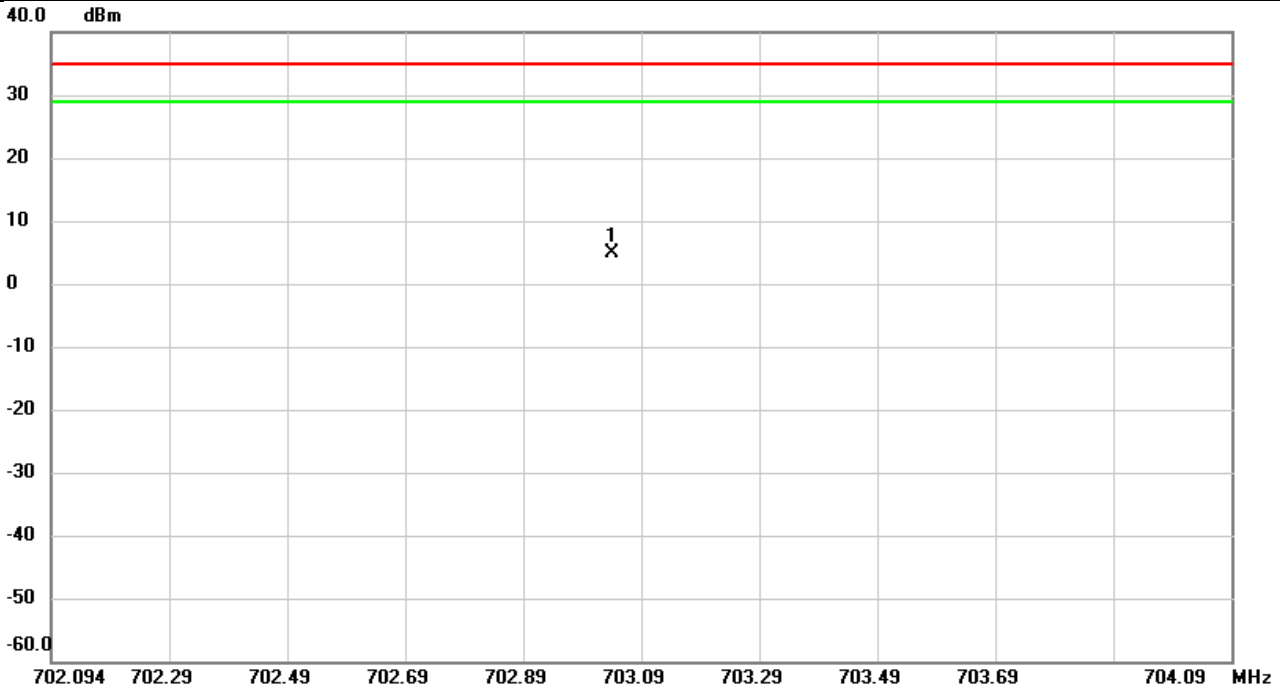

No.	Mk.	Freq.	Reading Level	Correct Factor	Measurement	Limit	Over	Detector	Comment
		MHz	dBm	dB	dBm	dBm	dB		
1	*	703.0440	-25.61	30.54	4.93	34.77	-29.84	peak	

REMARKS:

- (1) Measurement Value = Reading Level + Correct Factor.
- (2) Margin Level = Measurement Value - Limit Value.

Test Mode	LTE Band12	Test Date	2020/10/26
Test Channel	CH23130	Polarization	Vertical
Temp	22°C	Hum.	66%

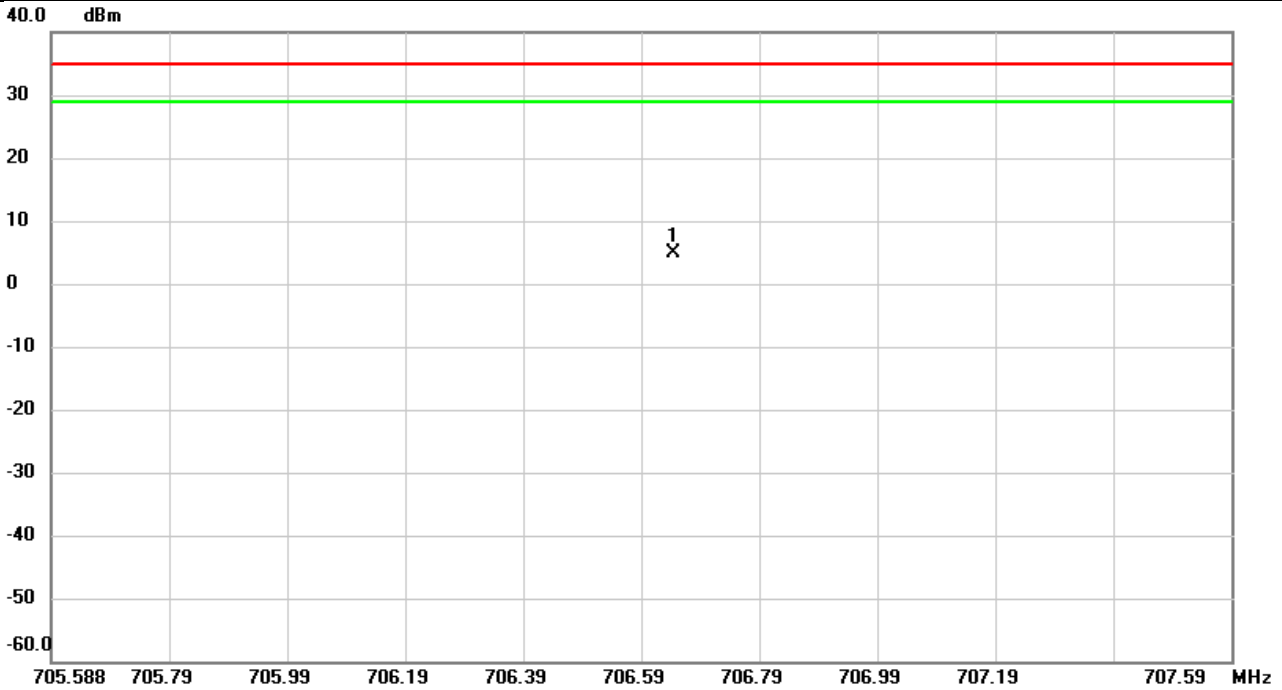

No.	Mk.	Freq. MHz	Reading Level dBm	Correct Factor dB	Measure- ment dBm	Limit dBm	Over dB	Detector	Comment
1	*	706.6420	-28.10	33.03	4.93	34.77	-29.84	peak	

REMARKS:

- (1) Measurement Value = Reading Level + Correct Factor.
- (2) Margin Level = Measurement Value - Limit Value.

Test Mode	LTE Band12	Test Date	2020/10/26
Test Channel	CH23130	Polarization	Horizontal
Temp	22°C	Hum.	66%

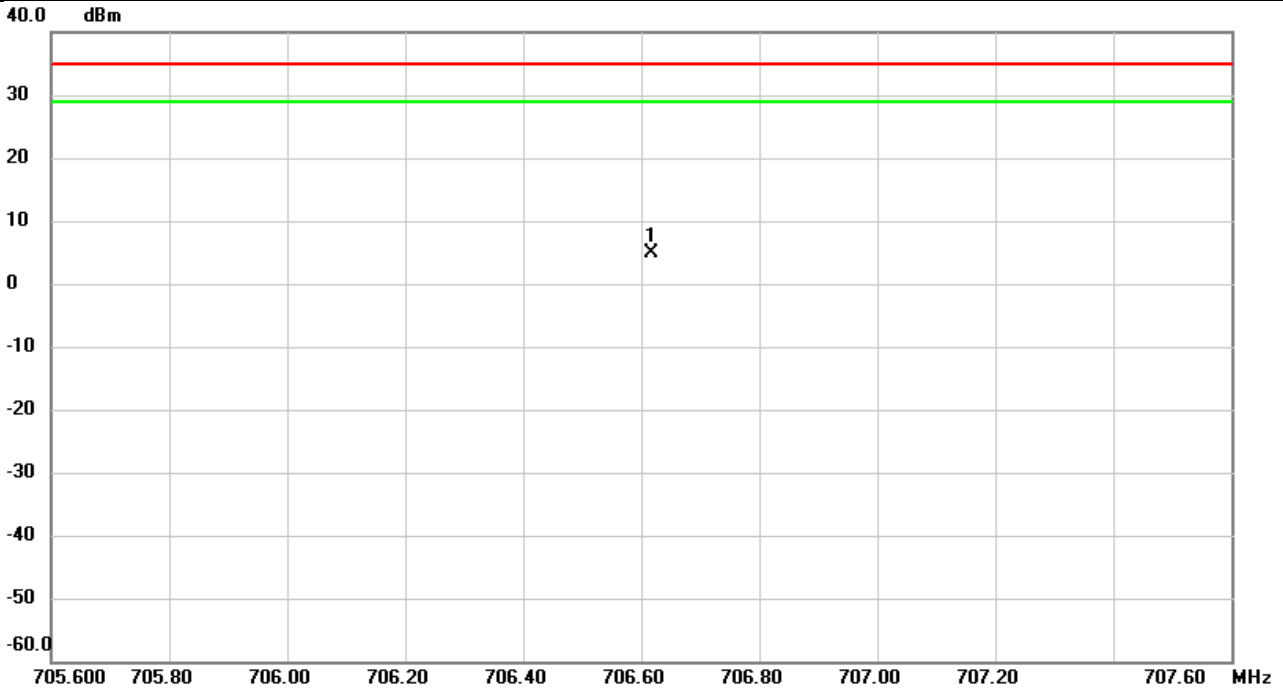

No.	Mk.	Freq.	Reading Level	Correct Factor	Measurement	Limit	Over	Detector	Comment
		MHz	dBm	dB	dBm	dBm	dB		
1	*	706.6180	-25.88	30.67	4.79	34.77	-29.98	peak	

**REMARKS:**

- (1) Measurement Value = Reading Level + Correct Factor.
- (2) Margin Level = Measurement Value - Limit Value.

Test Mode	LTE Band12	Test Date	2020/10/27
Test Channel	CH23095	Polarization	Vertical
Temp	22°C	Hum.	66%

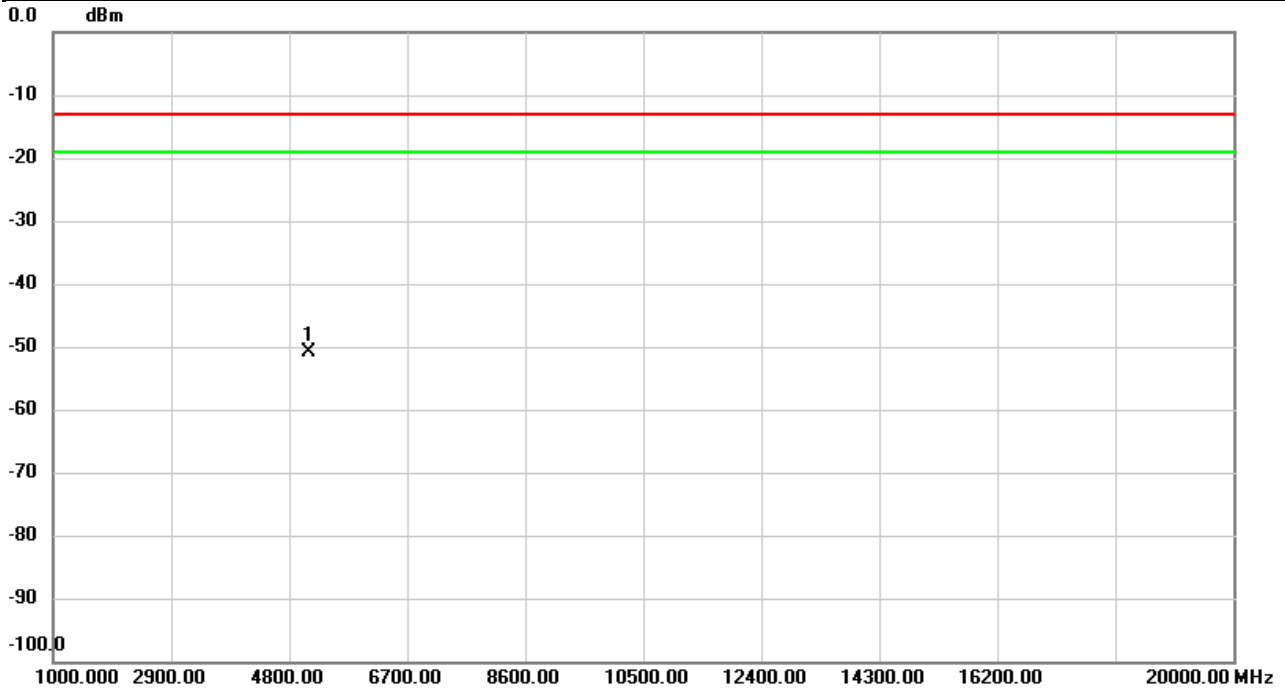

No.	Mk.	Freq.	Reading Level	Correct Factor	Measurement	Limit	Over	Detector	Comment
		MHz	dBm	dB	dBm	dBm	dB		
1	*	5104.000	-53.15	2.40	-50.75	-13.00	-37.75	peak	

REMARKS:

- (1) Measurement Value = Reading Level + Correct Factor.
- (2) Margin Level = Measurement Value - Limit Value.

Test Mode	LTE Band12	Test Date	2020/10/27
Test Channel	CH23095	Polarization	Horizontal
Temp	22°C	Hum.	66%

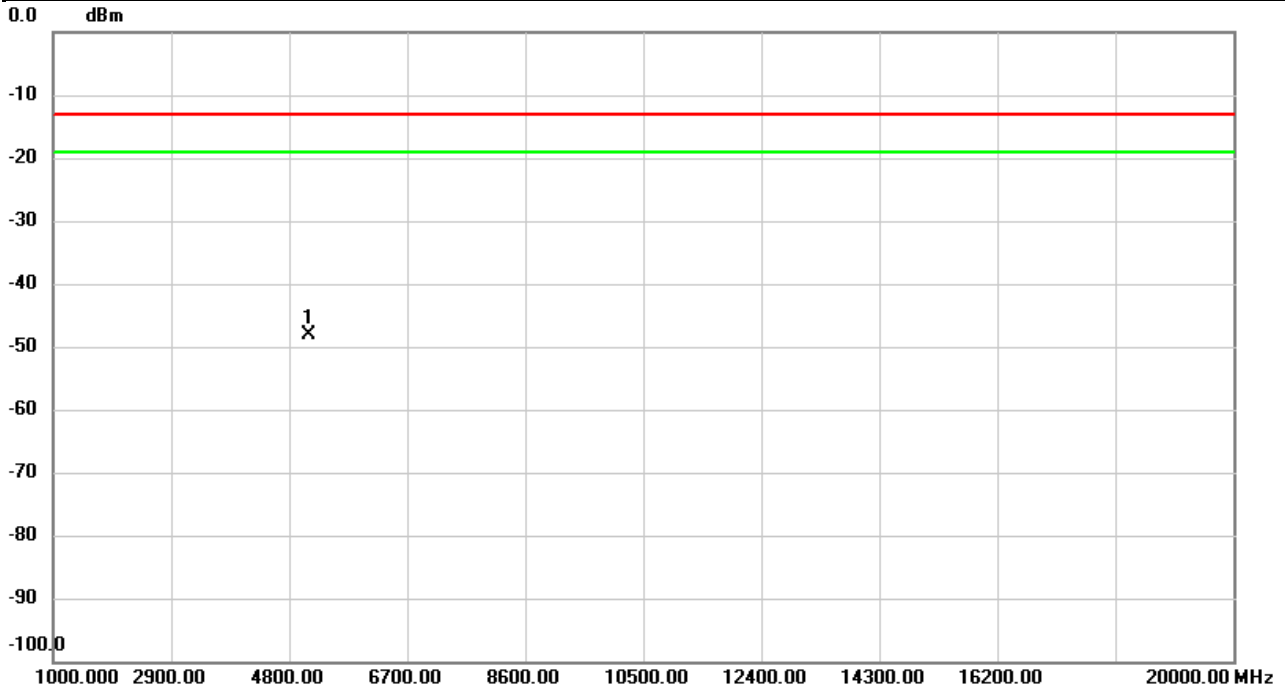

No.	Mk.	Freq.	Reading Level	Correct Factor	Measurement	Limit	Over	Detector	Comment
		MHz	dBm	dB	dBm	dBm	dB		
1	*	5104.000	-51.18	2.95	-48.23	-13.00	-35.23	peak	

REMARKS:

- (1) Measurement Value = Reading Level + Correct Factor.
- (2) Margin Level = Measurement Value - Limit Value.

Test Mode	LTE Band13	Test Date	2020/10/26
Test Channel	CH23230	Polarization	Vertical
Temp	22°C	Hum.	66%

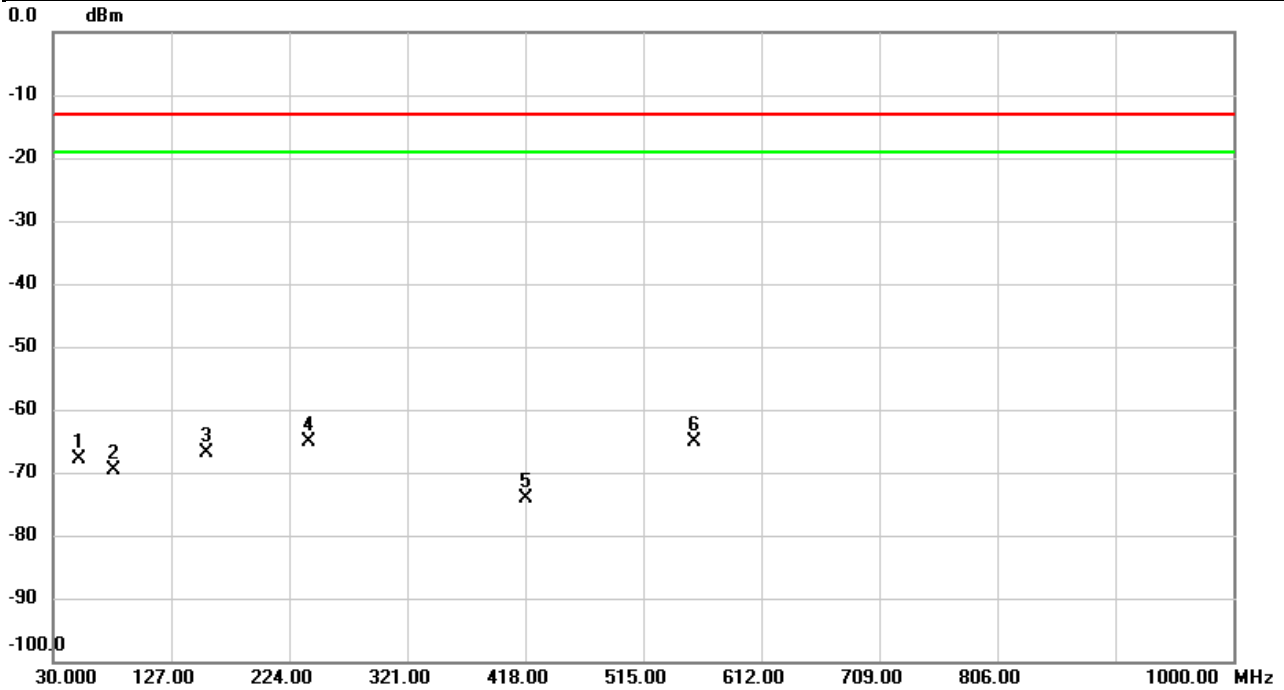

No.	Mk.	Freq. MHz	Reading Level dBm	Correct Factor dB	Measure- ment dBm	Limit dBm	Over dB	Detector	Comment
1		51.3400	-67.14	-0.74	-67.88	-13.00	-54.88	peak	
2		79.4700	-67.35	-2.15	-69.50	-13.00	-56.50	peak	
3		156.1000	-70.20	3.39	-66.81	-13.00	-53.81	peak	
4		240.4900	-72.44	7.35	-65.09	-13.00	-52.09	peak	
5		418.9700	-76.69	2.50	-74.19	-13.00	-61.19	peak	
6	*	556.7100	-74.51	9.44	-65.07	-13.00	-52.07	peak	

**REMARKS:**

- (1) Measurement Value = Reading Level + Correct Factor.
- (2) Margin Level = Measurement Value - Limit Value.

Test Mode	LTE Band13	Test Date	2020/10/26
Test Channel	CH23230	Polarization	Horizontal
Temp	22°C	Hum.	66%

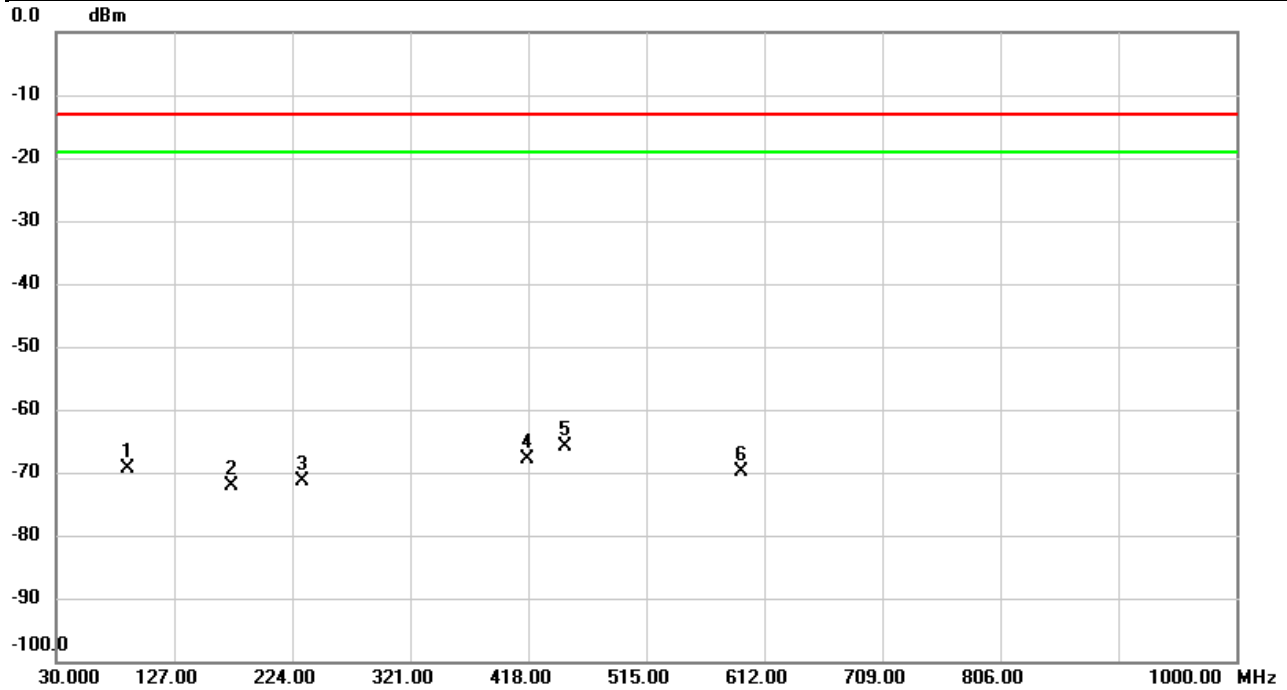

No.	Mk.	Freq.	Reading Level	Correct Factor	Measurement	Limit	Over	Detector	Comment
		MHz	dBm	dB	dBm	dBm	dB		
1		88.2000	-73.51	4.04	-69.47	-13.00	-56.47	peak	
2		173.5600	-73.98	1.91	-72.07	-13.00	-59.07	peak	
3		231.7600	-70.99	-0.45	-71.44	-13.00	-58.44	peak	
4		417.0300	-76.06	8.28	-67.78	-13.00	-54.78	peak	
5	*	448.0700	-77.89	12.11	-65.78	-13.00	-52.78	peak	
6		592.6000	-77.26	7.47	-69.79	-13.00	-56.79	peak	

**REMARKS:**

- (1) Measurement Value = Reading Level + Correct Factor.
- (2) Margin Level = Measurement Value - Limit Value.

Test Mode	LTE Band13	Test Date	2020/10/26
Test Channel	CH23230	Polarization	Vertical
Temp	22°C	Hum.	66%

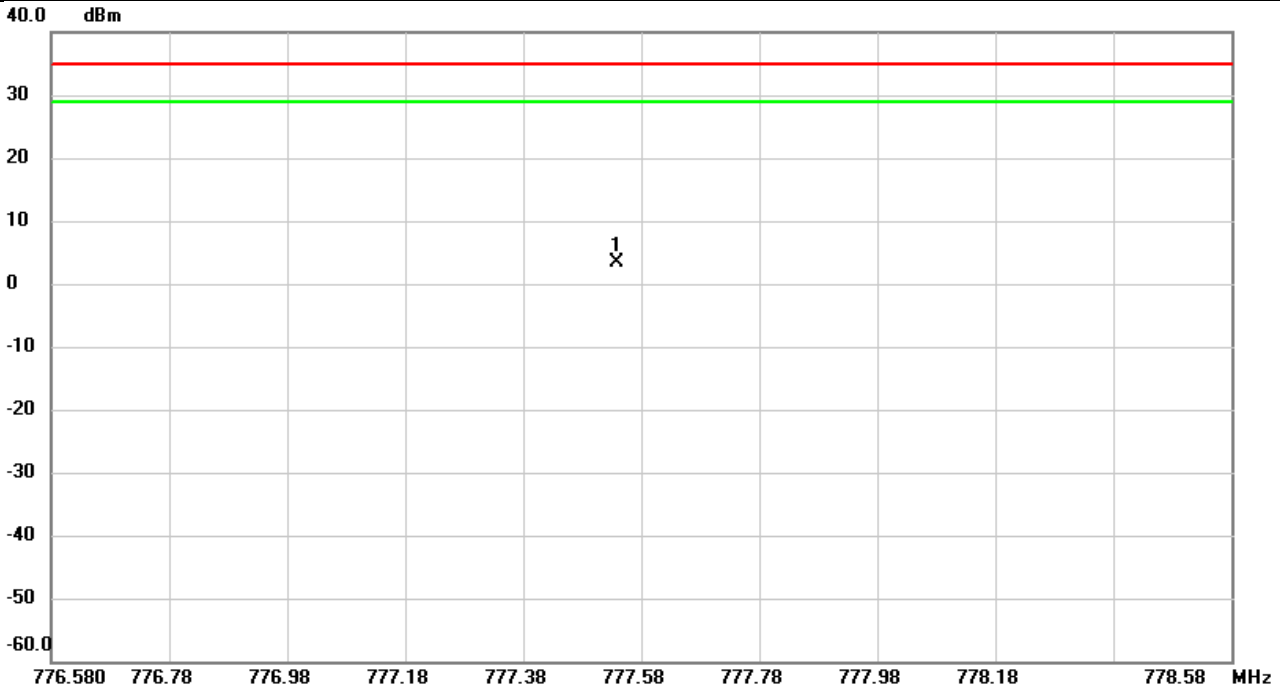

No.	Mk.	Freq.	Reading Level	Correct Factor	Measurement	Limit	Over	Detector	Comment
		MHz	dBm	dB	dBm	dBm	dB		
1	*	777.5400	-30.48	33.94	3.46	34.77	-31.31	peak	

REMARKS:

- (1) Measurement Value = Reading Level + Correct Factor.
- (2) Margin Level = Measurement Value - Limit Value.



Test Mode	LTE Band13	Test Date	2020/10/26
Test Channel	CH23230	Polarization	Horizontal
Temp	22°C	Hum.	66%

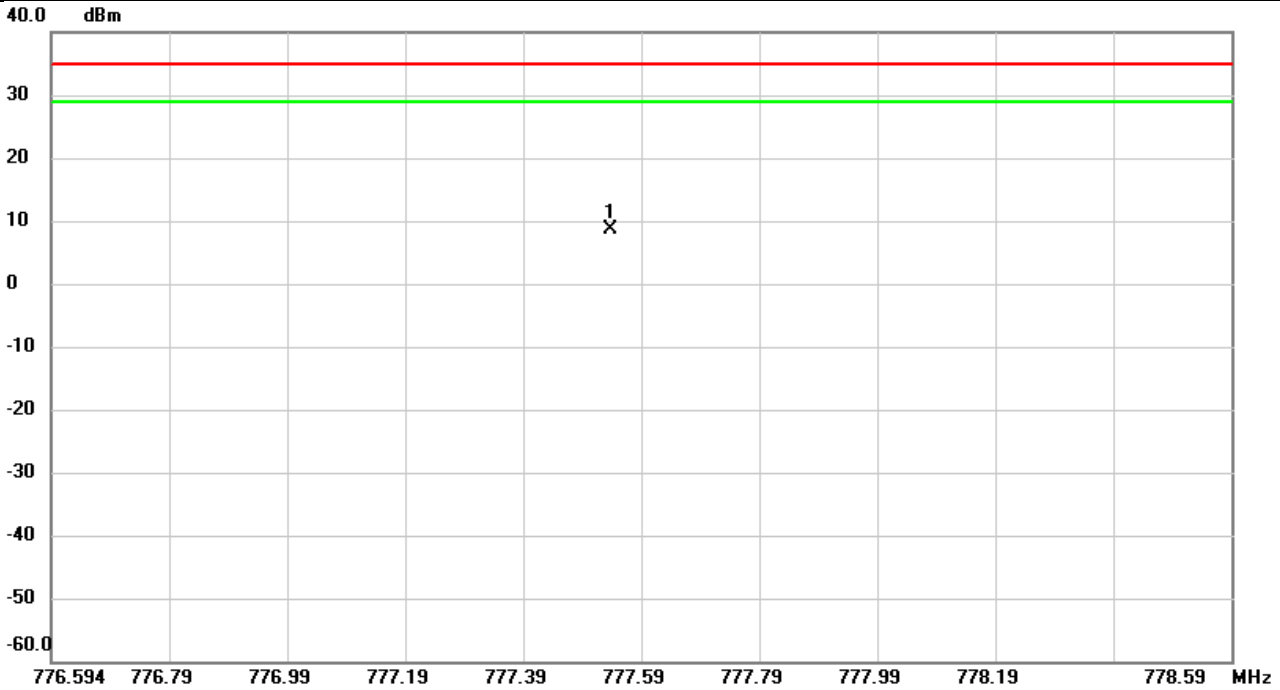

No.	Mk.	Freq.	Reading Level	Correct Factor	Measurement	Limit	Over	Detector	Comment
		MHz	dBm	dB	dBm	dBm	dB		
1	*	777.5420	-24.25	32.95	8.70	34.77	-26.07	peak	

REMARKS:

- (1) Measurement Value = Reading Level + Correct Factor.
- (2) Margin Level = Measurement Value - Limit Value.

Test Mode	LTE Band13	Test Date	2020/10/27
Test Channel	CH23230	Polarization	Vertical
Temp	22°C	Hum.	66%

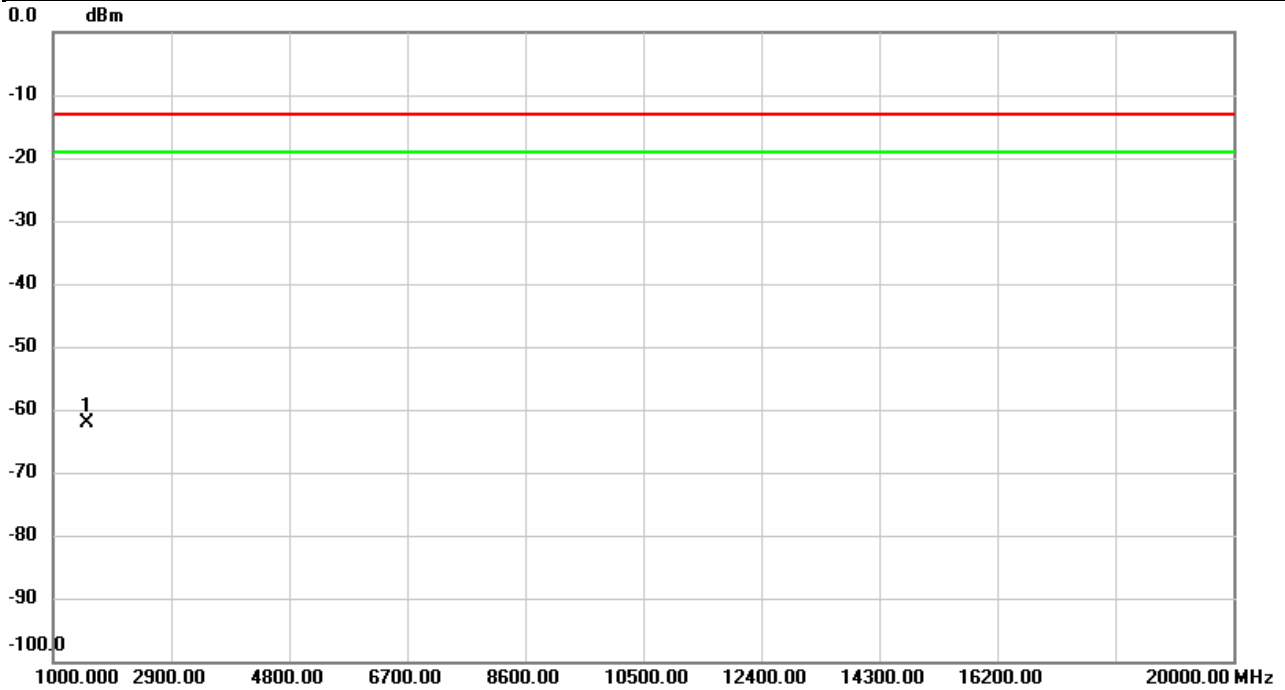

No.	Mk.	Freq.	Reading Level	Correct Factor	Measurement	Limit	Over	Detector	Comment
		MHz	dBm	dB	dBm	dBm	dB		
1	*	1551.000	-53.30	-8.70	-62.00	-13.00	-49.00	peak	

REMARKS:

- (1) Measurement Value = Reading Level + Correct Factor.
- (2) Margin Level = Measurement Value - Limit Value.

Test Mode	LTE Band13	Test Date	2020/10/27
Test Channel	CH23230	Polarization	Horizontal
Temp	20°C	Hum.	68%

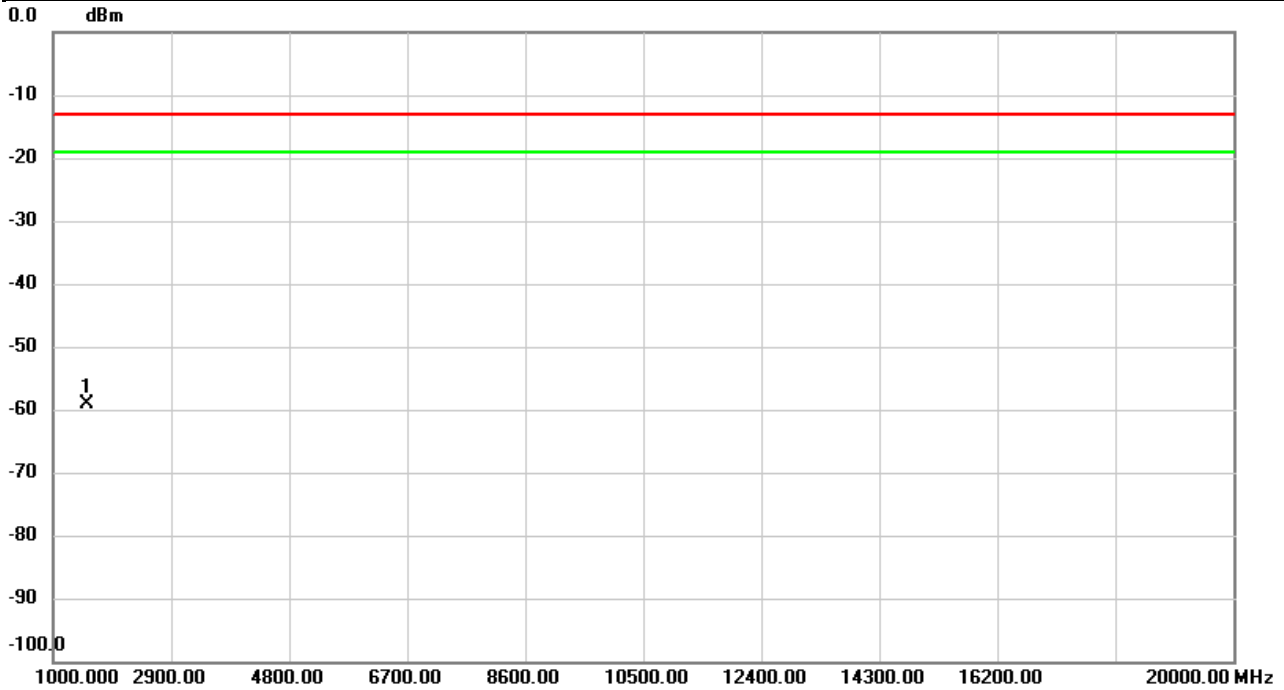

No.	Mk.	Freq. MHz	Reading Level dBm	Correct Factor dB	Measure- ment dBm	Limit dBm	Over dB	Detector	Comment
1	*	1551.000	-51.12	-7.96	-59.08	-13.00	-46.08	peak	

**REMARKS:**

- (1) Measurement Value = Reading Level + Correct Factor.
- (2) Margin Level = Measurement Value - Limit Value.

Test Mode	LTE Band17	Test Date	2020/10/26
Test Channel	CH23790	Polarization	Vertical
Temp	22°C	Hum.	66%

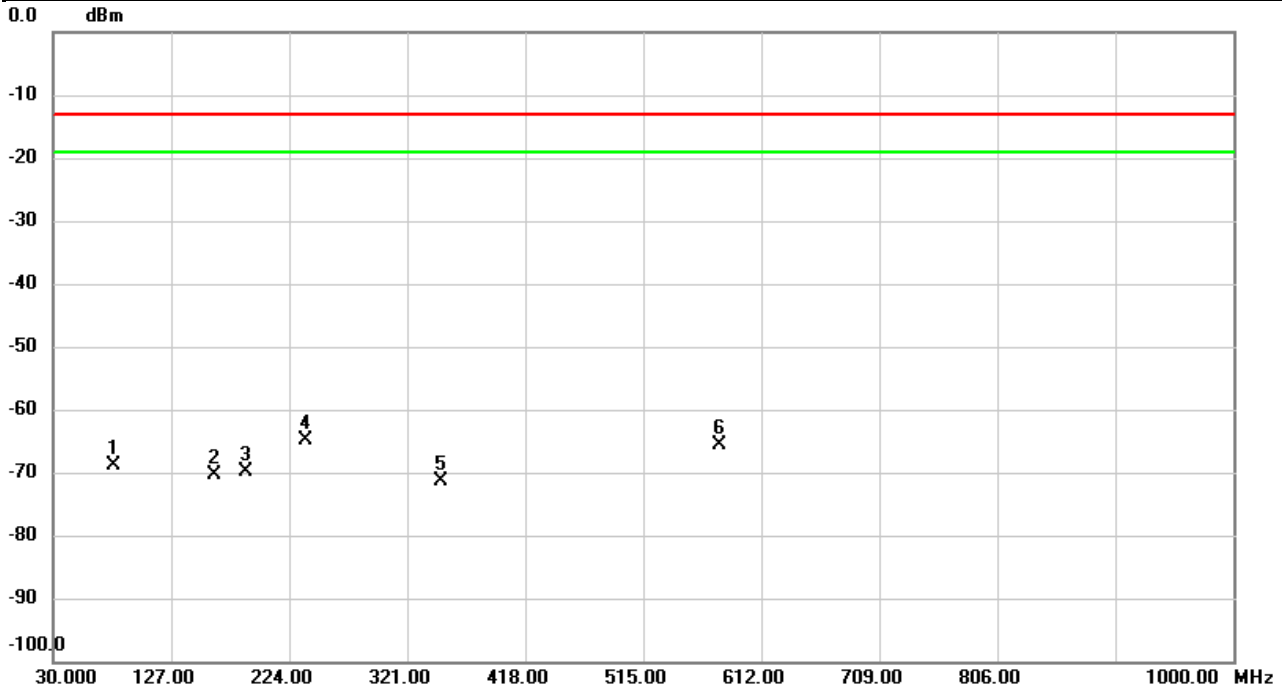

No.	Mk.	Freq. MHz	Reading Level dBm	Correct Factor dB	Measure- ment dBm	Limit dBm	Over dB	Detector	Comment
1		79.4700	-66.68	-2.15	-68.83	-13.00	-55.83	peak	
2		161.9200	-73.82	3.49	-70.33	-13.00	-57.33	peak	
3		188.1100	-73.89	3.99	-69.90	-13.00	-56.90	peak	
4	*	237.5800	-71.34	6.46	-64.88	-13.00	-51.88	peak	
5		349.1300	-77.92	6.66	-71.26	-13.00	-58.26	peak	
6		578.0500	-76.43	10.78	-65.65	-13.00	-52.65	peak	

**REMARKS:**

- (1) Measurement Value = Reading Level + Correct Factor.
- (2) Margin Level = Measurement Value - Limit Value.

Test Mode	LTE Band17	Test Date	2020/10/26
Test Channel	CH23790	Polarization	Horizontal
Temp	22°C	Hum.	66%

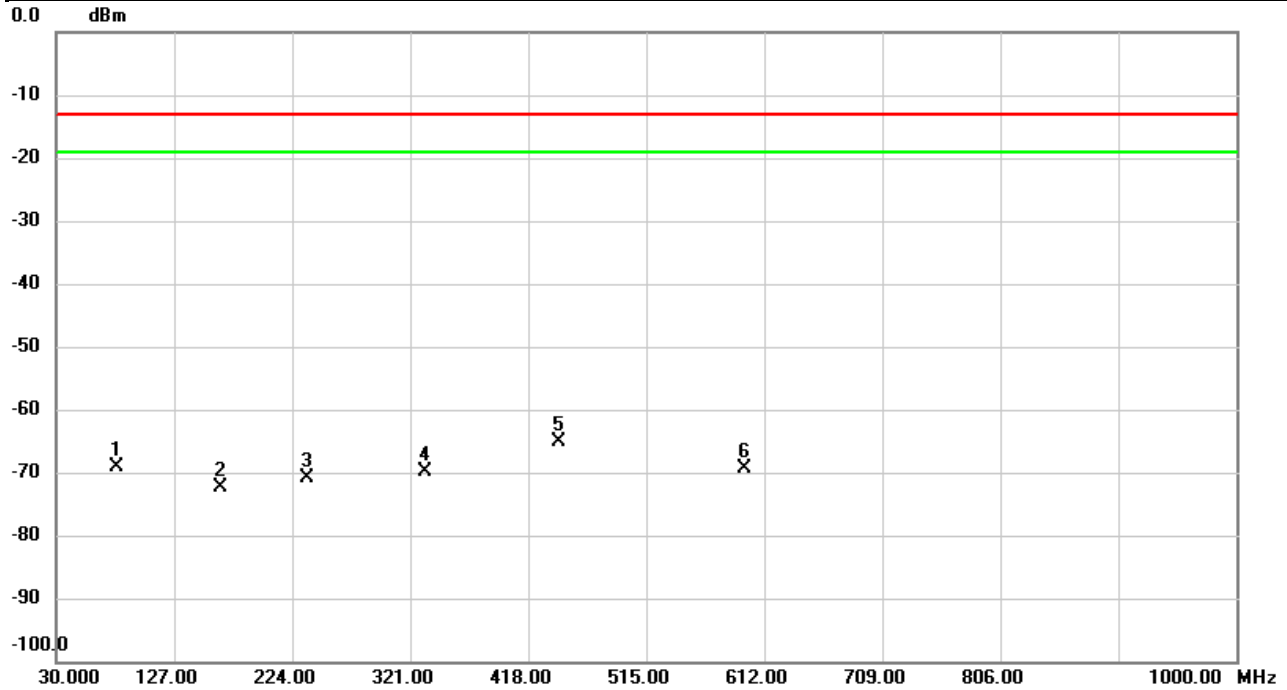

No.	Mk.	Freq. MHz	Reading Level dBm	Correct Factor dB	Measure- ment dBm	Limit dBm	Over dB	Detector	Comment
1		79.4700	-74.68	5.67	-69.01	-13.00	-56.01	peak	
2		164.8300	-74.83	2.41	-72.42	-13.00	-59.42	peak	
3		235.6400	-70.49	-0.46	-70.95	-13.00	-57.95	peak	
4		332.6400	-72.88	2.96	-69.92	-13.00	-56.92	peak	
5	*	443.2200	-76.51	11.51	-65.00	-13.00	-52.00	peak	
6		595.5100	-76.67	7.38	-69.29	-13.00	-56.29	peak	

**REMARKS:**

- (1) Measurement Value = Reading Level + Correct Factor.
- (2) Margin Level = Measurement Value - Limit Value.

Test Mode	LTE Band17	Test Date	2020/10/26
Test Channel	CH23780	Polarization	Vertical
Temp	22°C	Hum.	66%

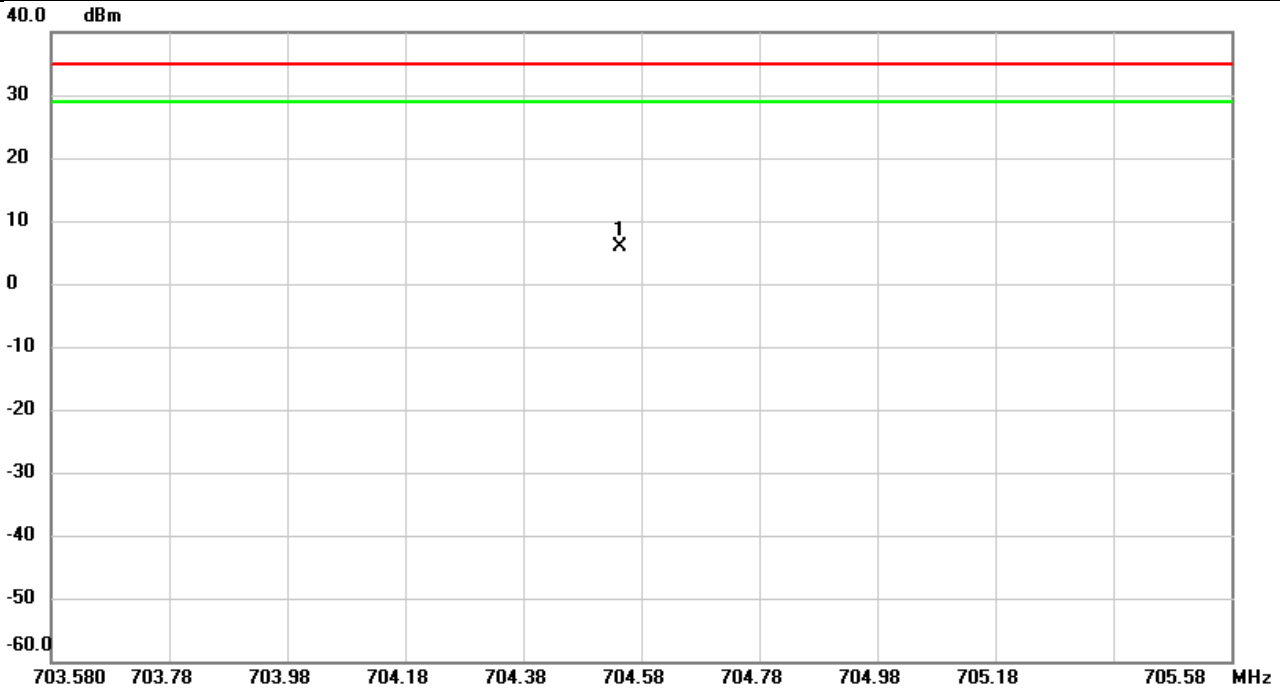

No.	Mk.	Freq.	Reading Level	Correct Factor	Measurement	Limit	Over	Detector	Comment
		MHz	dBm	dB	dBm	dBm	dB		
1	*	704.5440	-27.14	33.00	5.86	34.77	-28.91	peak	

REMARKS:

- (1) Measurement Value = Reading Level + Correct Factor.
- (2) Margin Level = Measurement Value - Limit Value.

Test Mode	LTE Band17	Test Date	2020/10/26
Test Channel	CH23780	Polarization	Horizontal
Temp	22°C	Hum.	66%

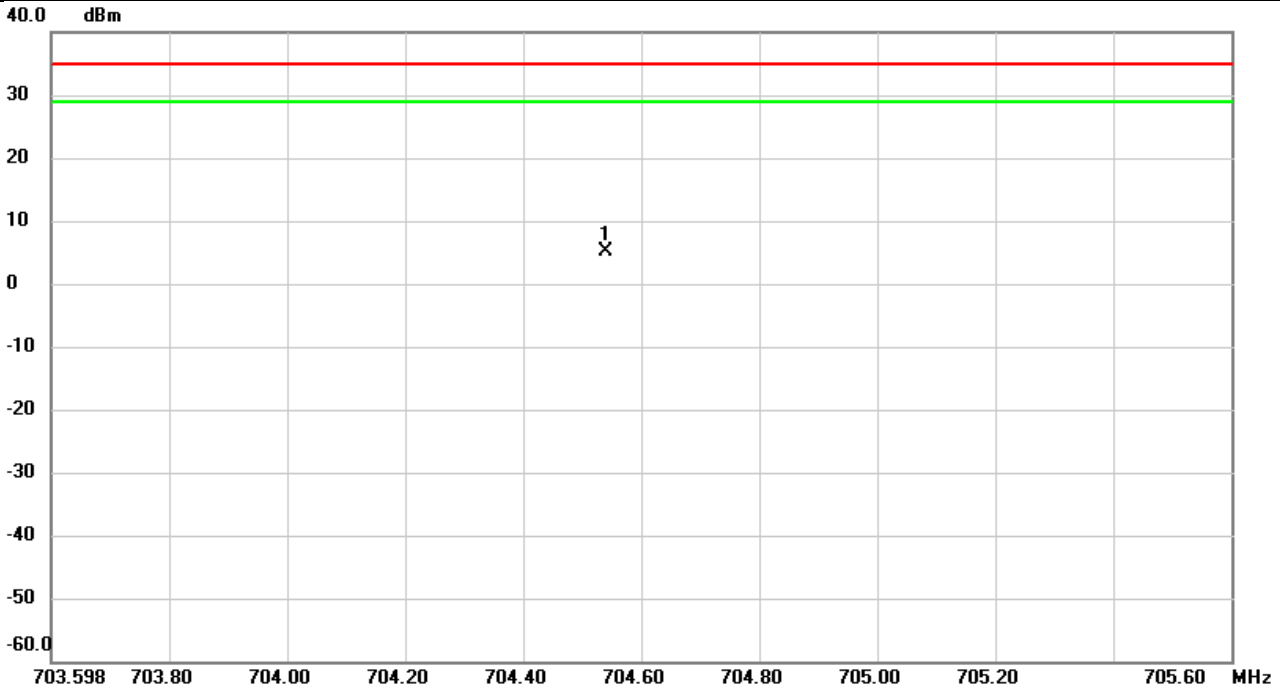

No.	Mk.	Freq.	Reading Level	Correct Factor	Measurement	Limit	Over	Detector	Comment
		MHz	dBm	dB	dBm	dBm	dB		
1	*	704.5380	-25.43	30.59	5.16	34.77	-29.61	peak	

REMARKS:

- (1) Measurement Value = Reading Level + Correct Factor.
- (2) Margin Level = Measurement Value - Limit Value.

Test Mode	LTE Band17	Test Date	2020/10/26
Test Channel	CH23790	Polarization	Vertical
Temp	22°C	Hum.	66%

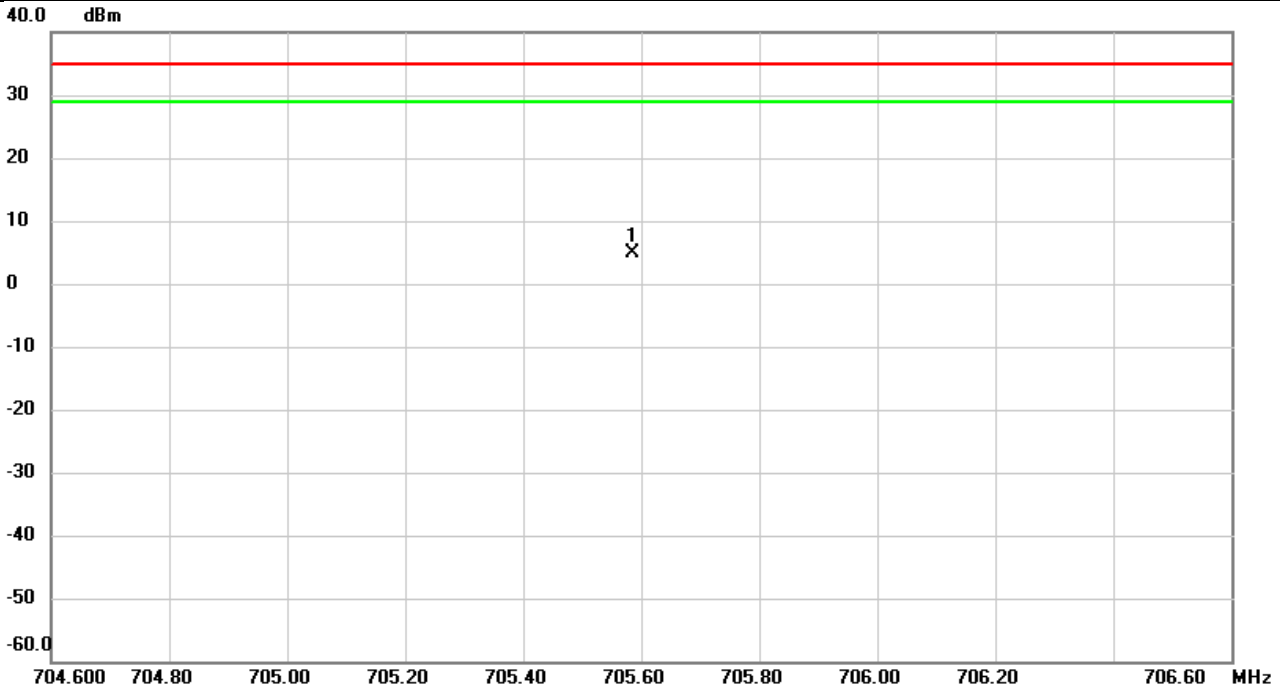

No.	Mk.	Freq.	Reading Level	Correct Factor	Measurement	Limit	Over	Detector	Comment
		MHz	dBm	dB	dBm	dBm	dB		
1	*	705.5860	-28.15	33.01	4.86	34.77	-29.91	peak	

REMARKS:

- (1) Measurement Value = Reading Level + Correct Factor.
- (2) Margin Level = Measurement Value - Limit Value.



Test Mode	LTE Band17	Test Date	2020/10/26
Test Channel	CH23790	Polarization	Horizontal
Temp	22°C	Hum.	66%

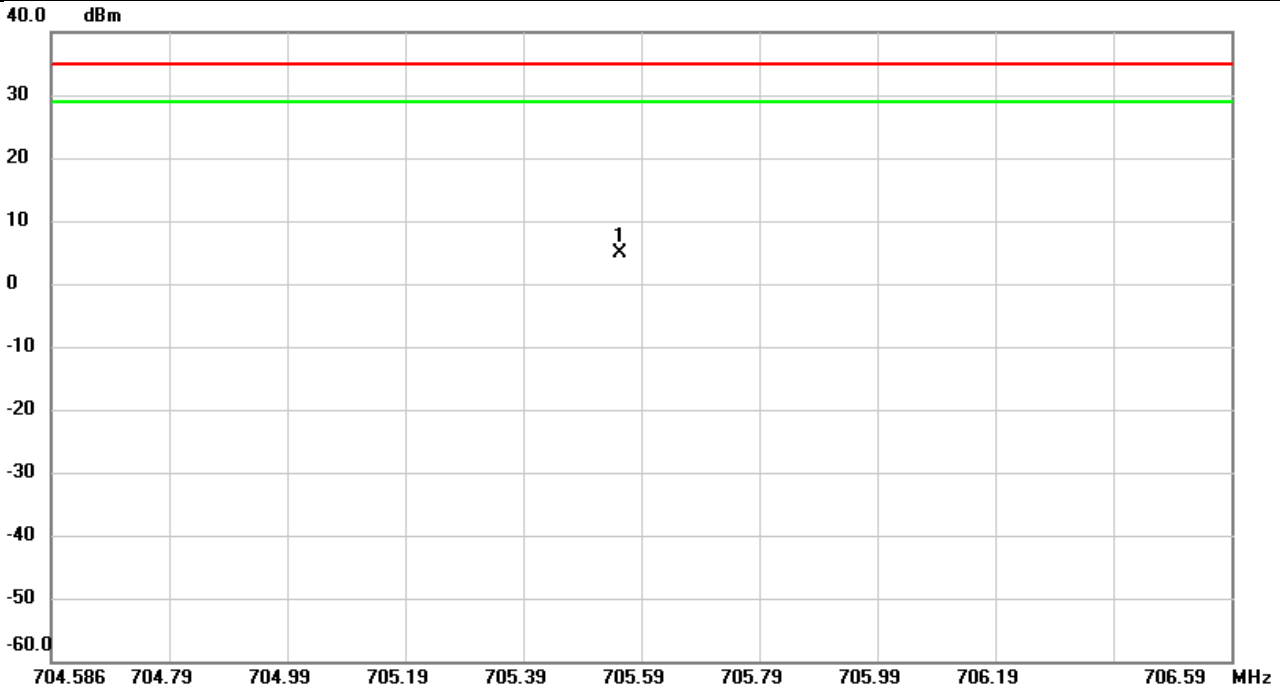

No.	Mk.	Freq. MHz	Reading Level dBm	Correct Factor dB	Measure- ment dBm	Limit dBm	Over dB	Detector	Comment
1	*	705.5500	-25.69	30.63	4.94	34.77	-29.83	peak	

REMARKS:

- (1) Measurement Value = Reading Level + Correct Factor.
- (2) Margin Level = Measurement Value - Limit Value.

Test Mode	LTE Band17	Test Date	2020/10/26
Test Channel	CH23800	Polarization	Vertical
Temp	22°C	Hum.	66%

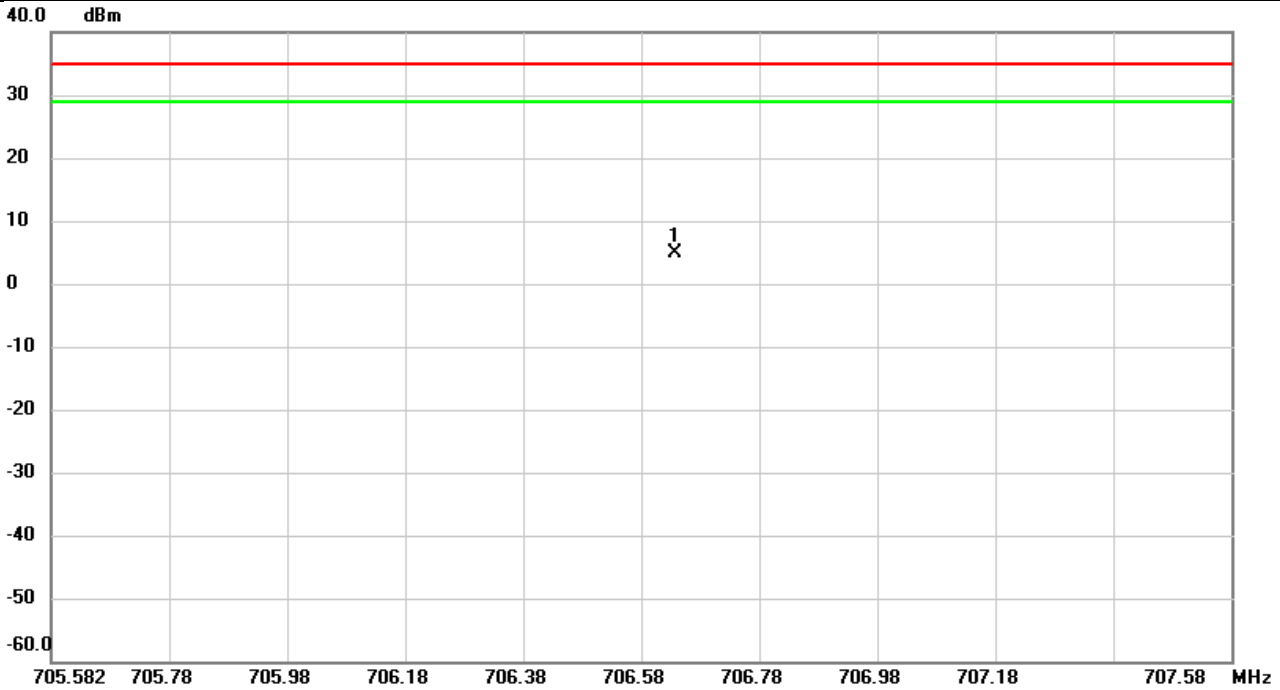

No.	Mk.	Freq.	Reading Level	Correct Factor	Measurement	Limit	Over	Detector	Comment
		MHz	dBm	dB	dBm	dBm	dB		
1	*	706.6380	-28.06	33.03	4.97	34.77	-29.80	peak	

REMARKS:

- (1) Measurement Value = Reading Level + Correct Factor.
- (2) Margin Level = Measurement Value - Limit Value.

Test Mode	LTE Band17	Test Date	2020/10/26
Test Channel	CH23800	Polarization	Horizontal
Temp	22°C	Hum.	66%

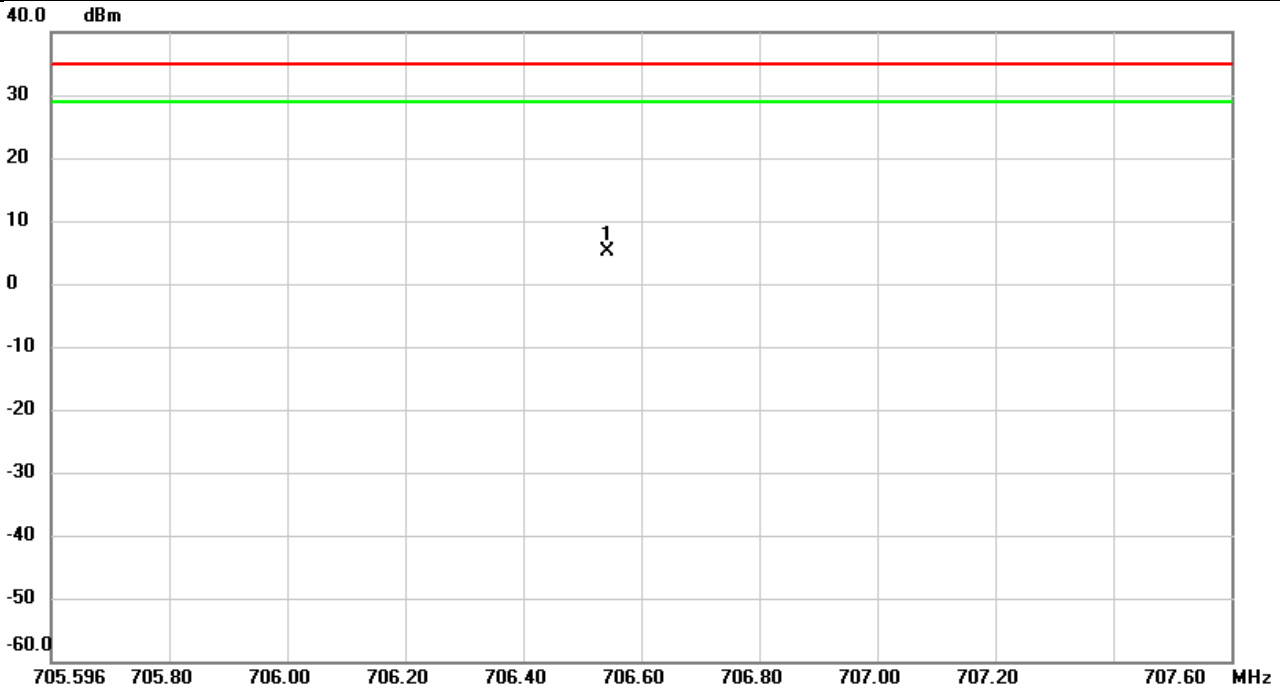

No.	Mk.	Freq.	Reading Level	Correct Factor	Measurement	Limit	Over	Detector	Comment
		MHz	dBm	dB	dBm	dBm	dB		
1	*	706.5400	-25.52	30.66	5.14	34.77	-29.63	peak	

REMARKS:

- (1) Measurement Value = Reading Level + Correct Factor.
- (2) Margin Level = Measurement Value - Limit Value.

Test Mode	LTE Band17	Test Date	2020/10/27
Test Channel	CH23790	Polarization	Vertical
Temp	20°C	Hum.	68%

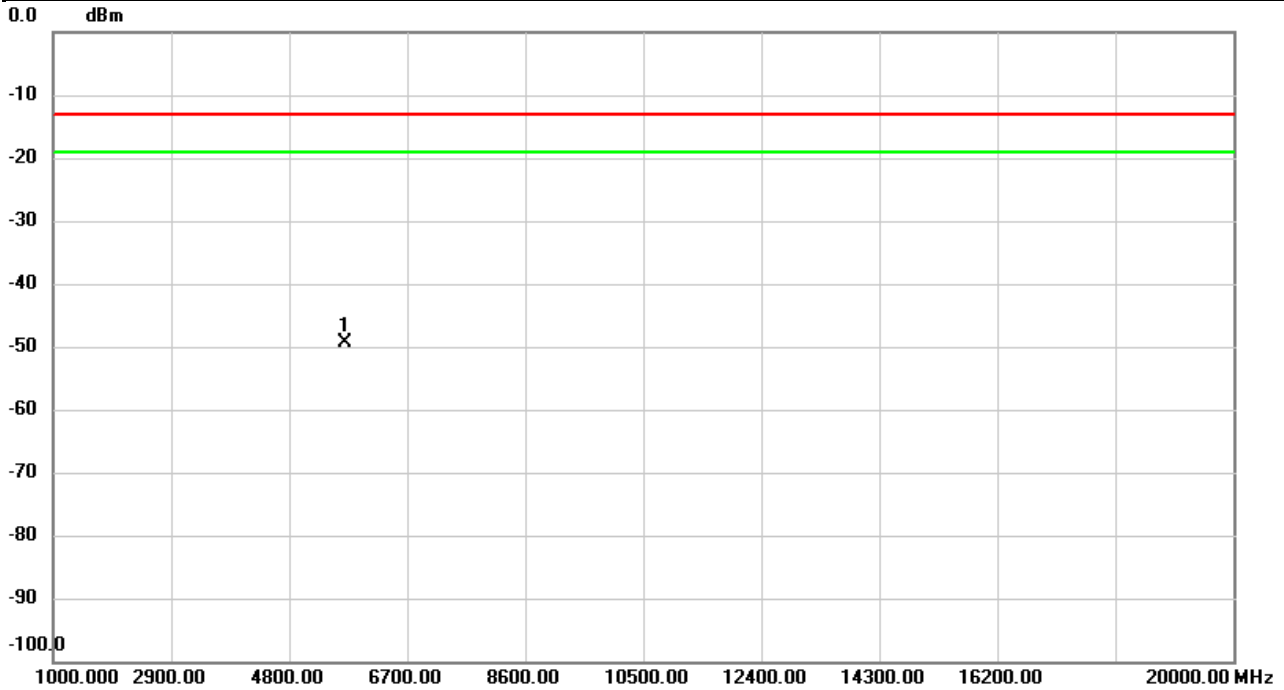

No.	Mk.	Freq.	Reading Level	Correct Factor	Measurement	Limit	Over	Detector	Comment
		MHz	dBm	dB	dBm	dBm	dB		
1	*	5693.000	-51.68	2.34	-49.34	-13.00	-36.34	peak	

REMARKS:

- (1) Measurement Value = Reading Level + Correct Factor.
- (2) Margin Level = Measurement Value - Limit Value.

Test Mode	LTE Band17	Test Date	2020/10/27
Test Channel	CH23790	Polarization	Horizontal
Temp	20°C	Hum.	68%

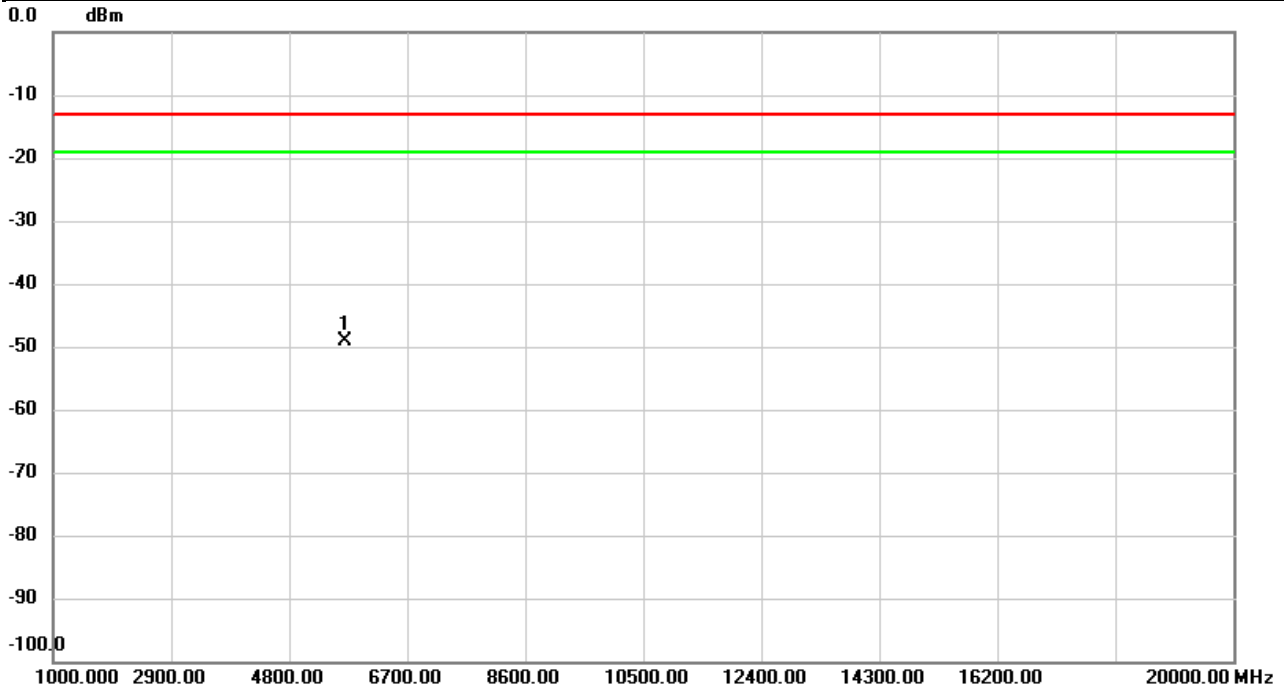

No.	Mk.	Freq.	Reading Level	Correct Factor	Measurement	Limit	Over	Detector	Comment
		MHz	dBm	dB	dBm	dBm	dB		
1	*	5693.000	-51.80	2.58	-49.22	-13.00	-36.22	peak	

REMARKS:

- (1) Measurement Value = Reading Level + Correct Factor.
- (2) Margin Level = Measurement Value - Limit Value.

Test Mode	LTE Band30	Test Date	2020/10/26
Test Channel	CH27710	Polarization	Vertical
Temp	22°C	Hum.	66%

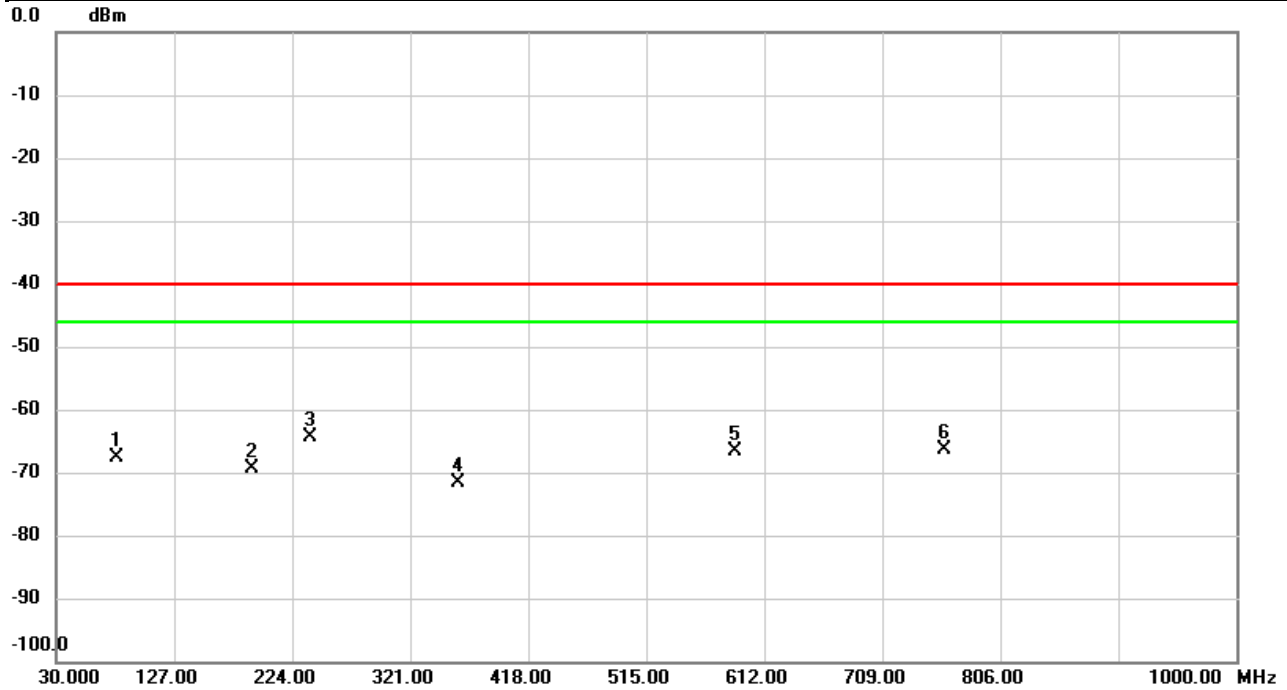

No.	Mk.	Freq.	Reading Level	Correct Factor	Measurement	Limit	Over	Detector	Comment
		MHz	dBm	dB	dBm	dBm	dB		
1		79.4700	-65.49	-2.15	-67.64	-40.00	-27.64	peak	
2		191.0200	-73.24	3.86	-69.38	-40.00	-29.38	peak	
3	*	238.5500	-71.28	6.81	-64.47	-40.00	-24.47	peak	
4		360.7700	-77.23	5.73	-71.50	-40.00	-31.50	peak	
5		587.7500	-77.90	11.38	-66.52	-40.00	-26.52	peak	
6		759.4400	-77.55	11.10	-66.45	-40.00	-26.45	peak	

**REMARKS:**

- (1) Measurement Value = Reading Level + Correct Factor.
- (2) Margin Level = Measurement Value - Limit Value.

Test Mode	LTE Band30	Test Date	2020/10/26
Test Channel	CH27710	Polarization	Horizontal
Temp	22°C	Hum.	66%

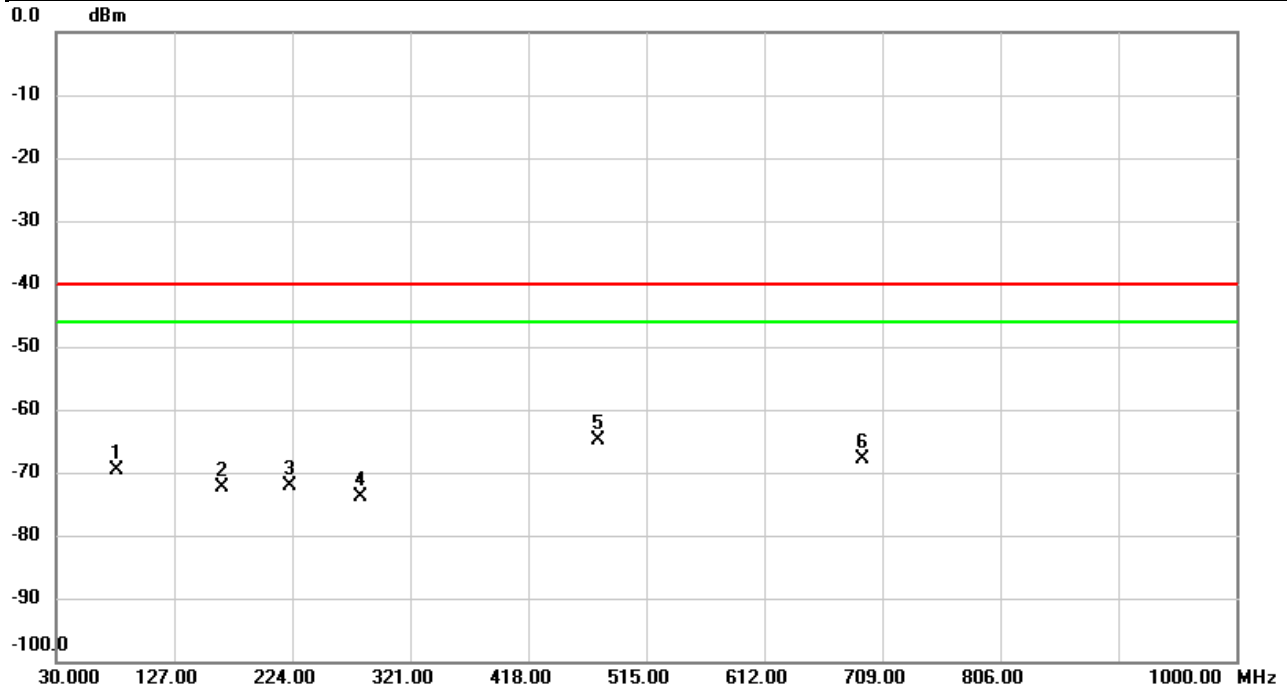

No.	Mk.	Freq. MHz	Reading Level dBm	Correct Factor dB	Measure- ment dBm	Limit dBm	Over dB	Detector	Comment
1		79.4700	-75.36	5.67	-69.69	-40.00	-29.69	peak	
2		165.8000	-74.77	2.36	-72.41	-40.00	-32.41	peak	
3		222.0600	-71.13	-1.06	-72.19	-40.00	-32.19	peak	
4		280.2600	-74.22	0.24	-73.98	-40.00	-33.98	peak	
5	*	475.2300	-76.84	11.91	-64.93	-40.00	-24.93	peak	
6		692.5100	-76.98	9.05	-67.93	-40.00	-27.93	peak	

**REMARKS:**

- (1) Measurement Value = Reading Level + Correct Factor.
- (2) Margin Level = Measurement Value - Limit Value.

Test Mode	LTE Band30	Test Date	2020/10/26
Test Channel	CH27710	Polarization	Vertical
Temp	22°C	Hum.	66%

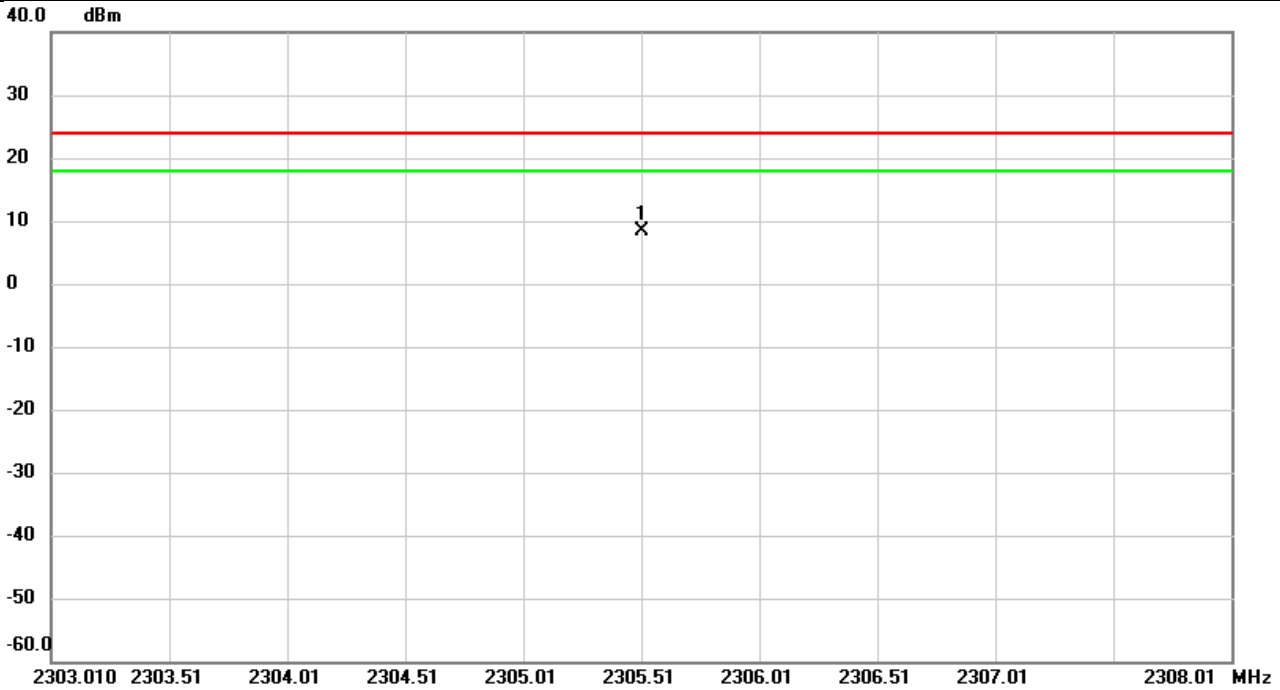

No.	Mk.	Freq. MHz	Reading Level dBm	Correct Factor dB	Measure- ment dBm	Limit dBm	Over dB	Detector	Comment
1	*	2305.515	-33.11	41.55	8.44	23.98	-15.54	peak	

REMARKS:

- (1) Measurement Value = Reading Level + Correct Factor.
- (2) Margin Level = Measurement Value - Limit Value.



Test Mode	LTE Band30	Test Date	2020/10/26
Test Channel	CH27710	Polarization	Horizontal
Temp	22°C	Hum.	66%

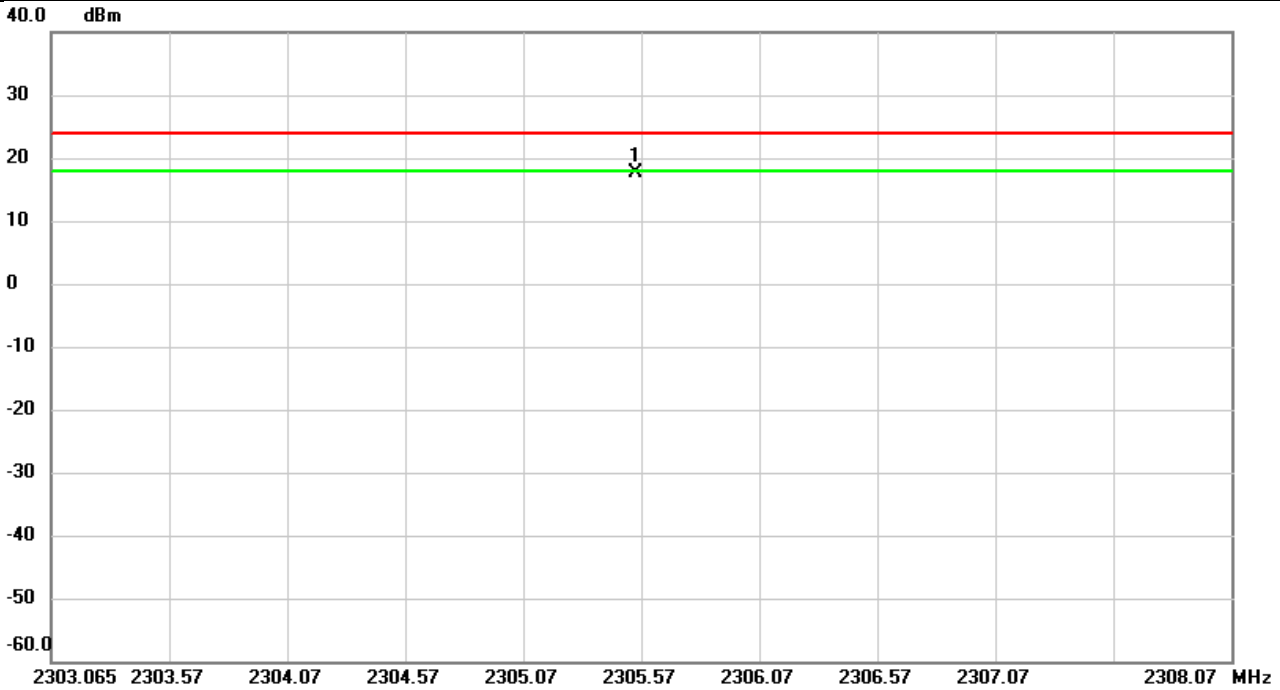

No.	Mk.	Freq.	Reading Level	Correct Factor	Measurement	Limit	Over	Detector	Comment
		MHz	dBm	dB	dBm	dBm	dB		
1	*	2305.540	-23.87	41.56	17.69	23.98	-6.29	peak	

REMARKS:

- (1) Measurement Value = Reading Level + Correct Factor.
- (2) Margin Level = Measurement Value - Limit Value.

Test Mode	LTE Band30	Test Date	2020/10/27
Test Channel	CH27710	Polarization	Vertical
Temp	20°C	Hum.	68%

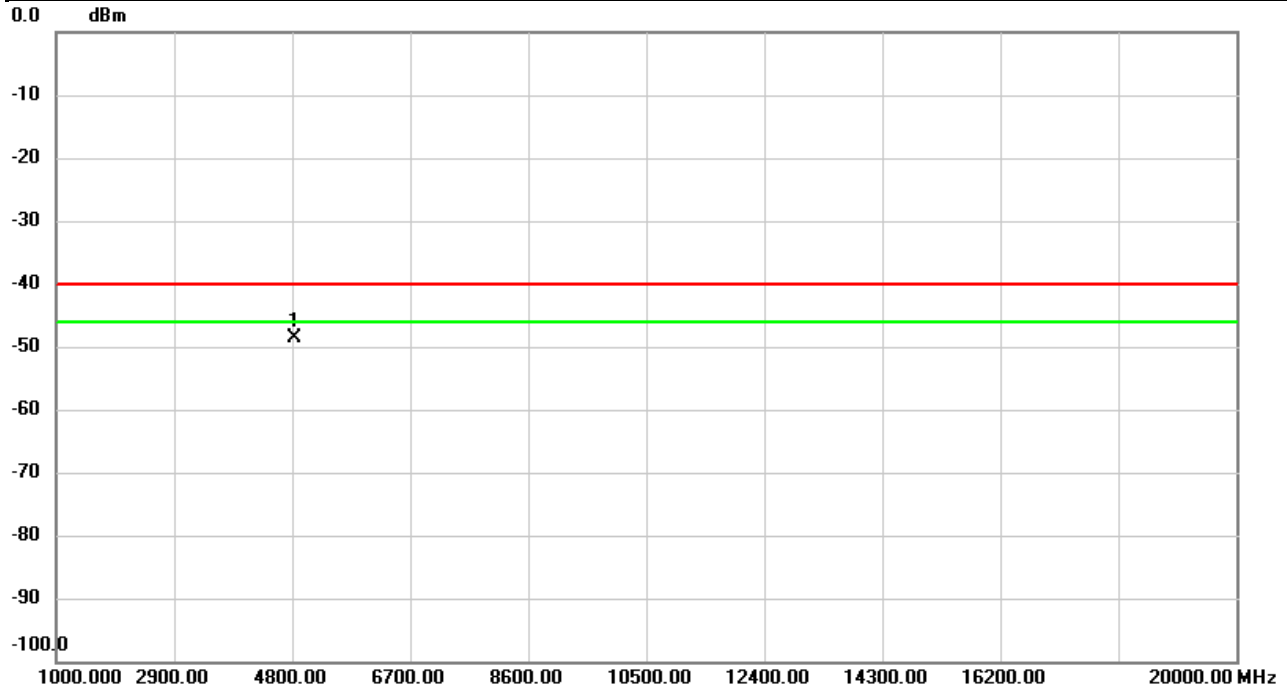

No.	Mk.	Freq.	Reading Level	Correct Factor	Measurement	Limit	Over	Detector	Comment
		MHz	dBm	dB	dBm	dBm	dB		
1	*	4838.000	-50.34	1.67	-48.67	-40.00	-8.67	peak	

REMARKS:

- (1) Measurement Value = Reading Level + Correct Factor.
- (2) Margin Level = Measurement Value - Limit Value.

Test Mode	LTE Band30	Test Date	2020/10/27
Test Channel	CH27710	Polarization	Horizontal
Temp	20°C	Hum.	68%

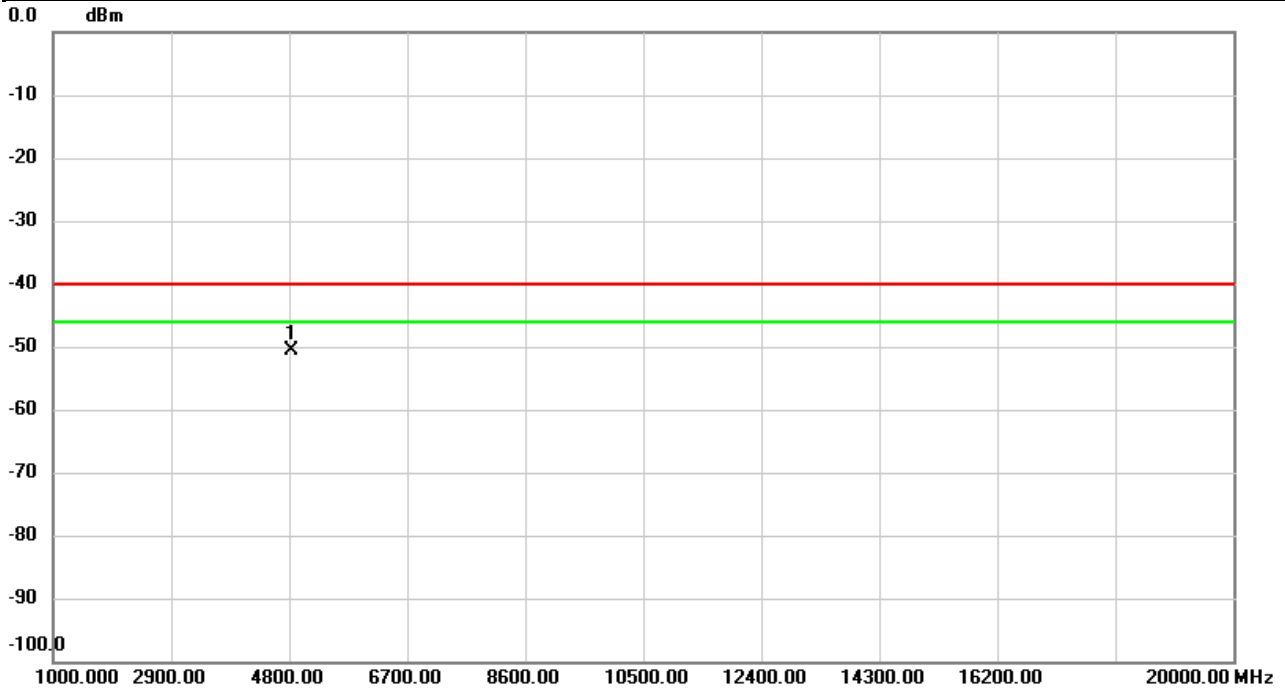

No.	Mk.	Freq.	Reading Level	Correct Factor	Measurement	Limit	Over	Detector	Comment
		MHz	dBm	dB	dBm	dBm	dB		
1	*	4838.000	-52.61	1.97	-50.64	-40.00	-10.64	peak	

REMARKS:

- (1) Measurement Value = Reading Level + Correct Factor.
- (2) Margin Level = Measurement Value - Limit Value.

Test Mode	LTE Band41	Test Date	2020/10/26
Test Channel	CH40620	Polarization	Vertical
Temp	22°C	Hum.	66%

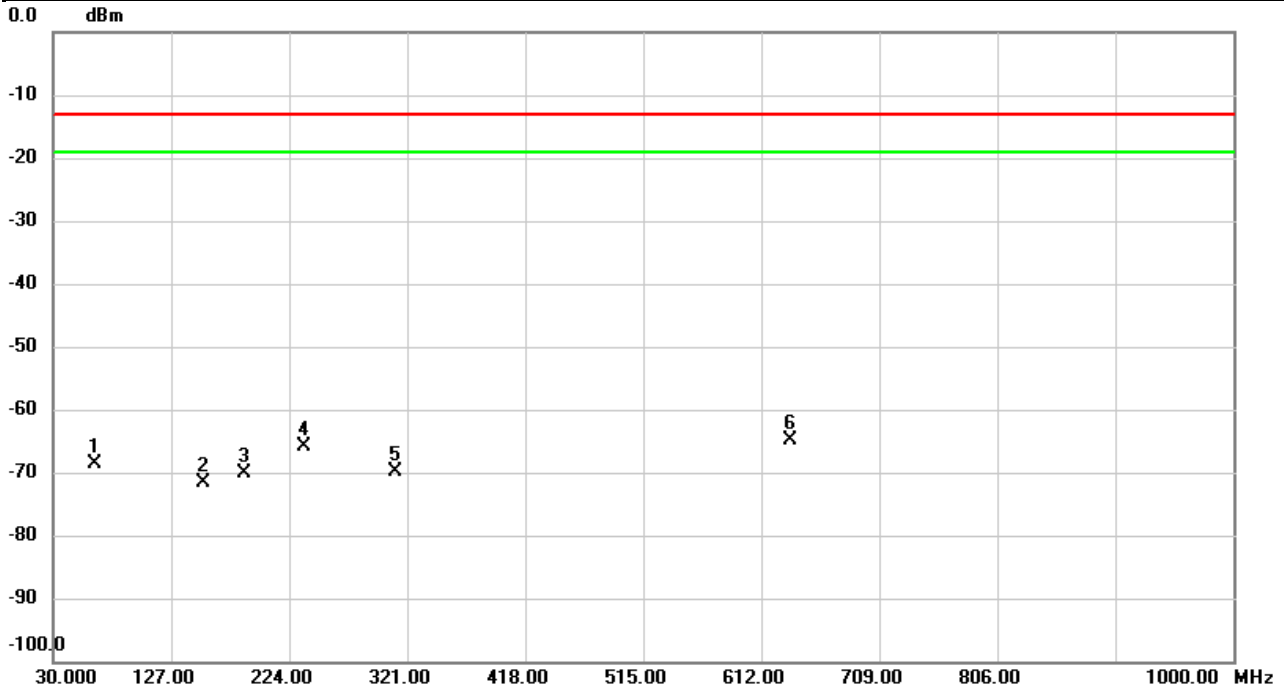

No.	Mk.	Freq. MHz	Reading Level dBm	Correct Factor dB	Measure- ment dBm	Limit dBm	Over dB	Detector	Comment
1		63.9500	-66.95	-1.76	-68.71	-13.00	-55.71	peak	
2		153.1900	-74.86	3.26	-71.60	-13.00	-58.60	peak	
3		187.1400	-73.97	3.97	-70.00	-13.00	-57.00	peak	
4		236.6100	-71.98	6.12	-65.86	-13.00	-52.86	peak	
5		311.3000	-77.31	7.39	-69.92	-13.00	-56.92	peak	
6	*	636.2500	-77.53	12.55	-64.98	-13.00	-51.98	peak	

**REMARKS:**

- (1) Measurement Value = Reading Level + Correct Factor.
- (2) Margin Level = Measurement Value - Limit Value.

Test Mode	LTE Band41	Test Date	2020/10/26
Test Channel	CH40620	Polarization	Horizontal
Temp	22°C	Hum.	66%

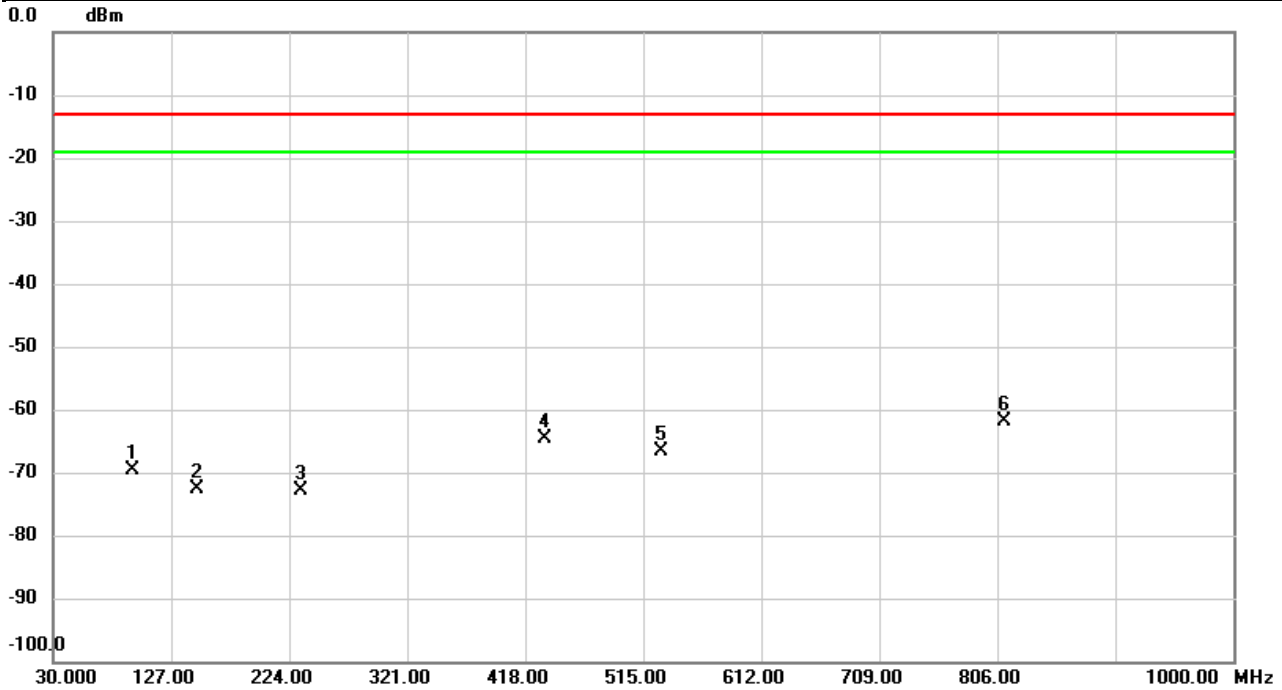

No.	Mk.	Freq. MHz	Reading Level dBm	Correct Factor dB	Measure- ment dBm	Limit dBm	Over dB	Detector	Comment
1		94.9900	-73.08	3.51	-69.57	-13.00	-56.57	peak	
2		148.3400	-75.38	2.87	-72.51	-13.00	-59.51	peak	
3		233.7000	-72.37	-0.46	-72.83	-13.00	-59.83	peak	
4		433.5200	-74.91	10.32	-64.59	-13.00	-51.59	peak	
5		529.5500	-76.18	9.60	-66.58	-13.00	-53.58	peak	
6	*	811.8200	-77.33	15.48	-61.85	-13.00	-48.85	peak	

**REMARKS:**

- (1) Measurement Value = Reading Level + Correct Factor.
- (2) Margin Level = Measurement Value - Limit Value.

Test Mode	LTE Band41	Test Date	2020/10/26
Test Channel	CH39750	Polarization	Vertical
Temp	22°C	Hum.	66%

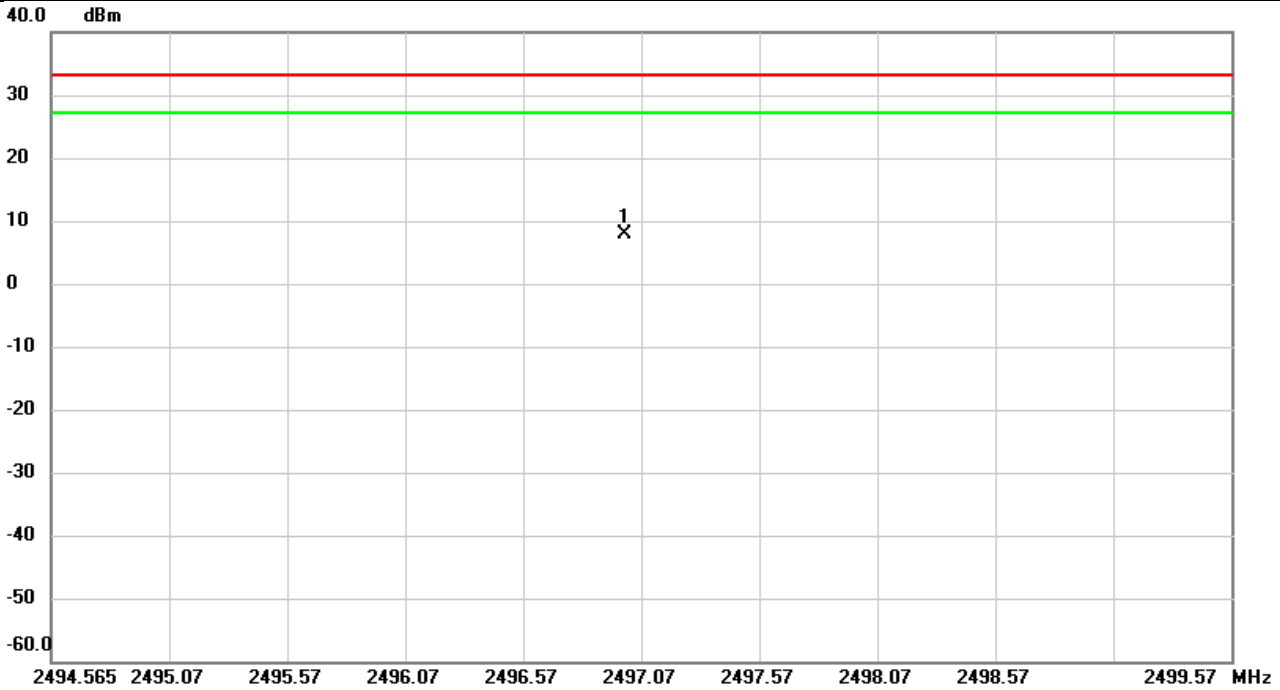

No.	Mk.	Freq. MHz	Reading Level dBm	Correct Factor dB	Measure- ment dBm	Limit dBm	Over dB	Detector	Comment
1	*	2496.995	-34.25	42.08	7.83	33.01	-25.18	peak	

**REMARKS:**

- (1) Measurement Value = Reading Level + Correct Factor.
- (2) Margin Level = Measurement Value - Limit Value.

Test Mode	LTE Band41	Test Date	2020/10/26
Test Channel	CH39750	Polarization	Horizontal
Temp	22°C	Hum.	66%

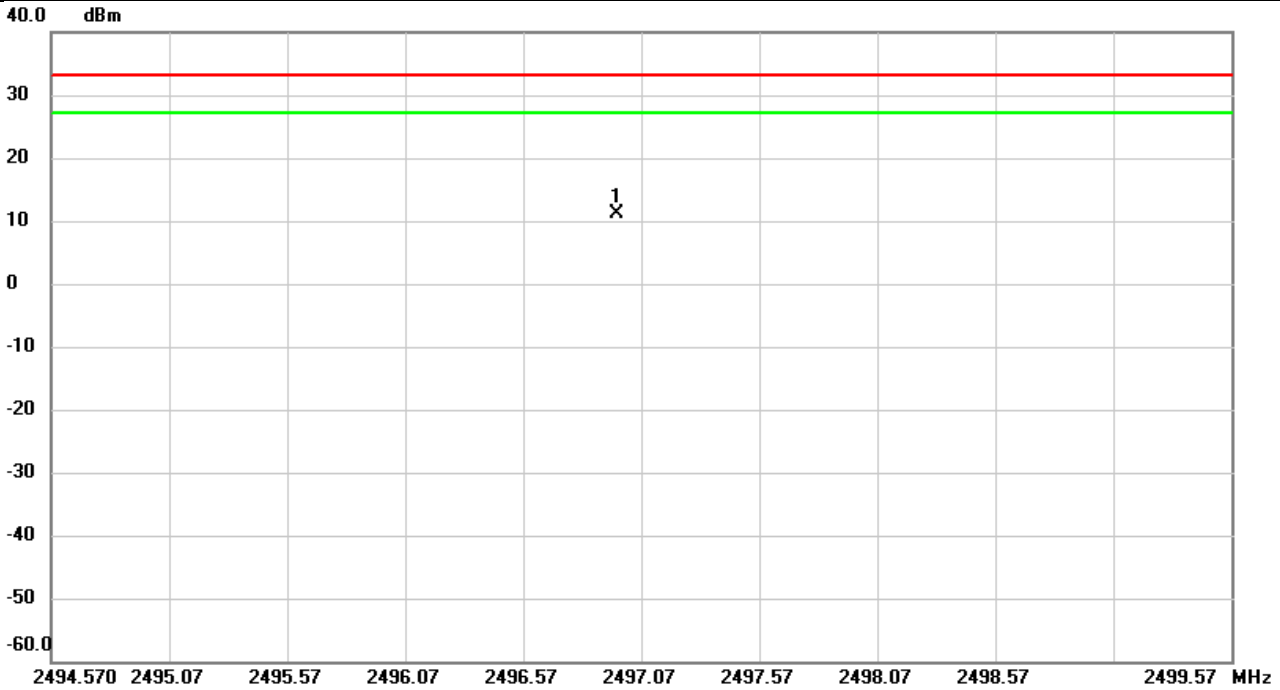

No.	Mk.	Freq. MHz	Reading Level dBm	Correct Factor dB	Measure- ment dBm	Limit dBm	Over dB	Detector	Comment
1	*	2496.970	-30.58	41.82	11.24	33.01	-21.77	peak	

**REMARKS:**

- (1) Measurement Value = Reading Level + Correct Factor.
- (2) Margin Level = Measurement Value - Limit Value.

Test Mode	LTE Band41	Test Date	2020/10/26
Test Channel	CH40620	Polarization	Vertical
Temp	22°C	Hum.	66%

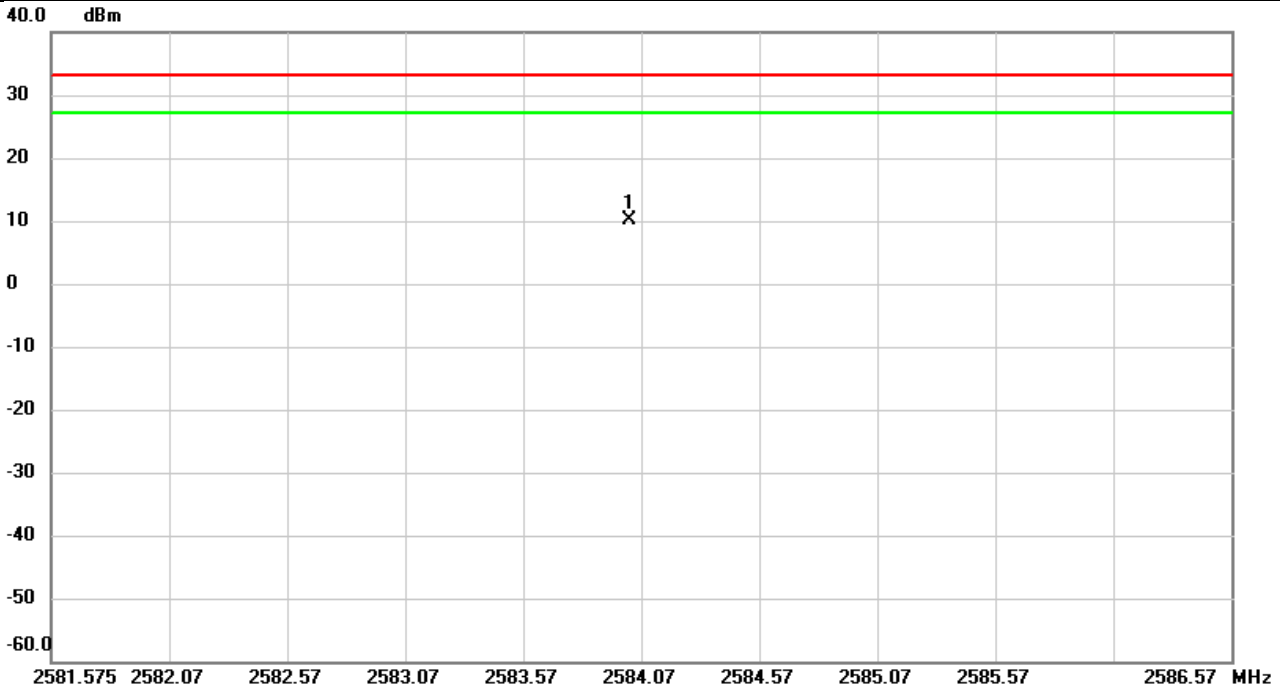

No.	Mk.	Freq.	Reading Level	Correct Factor	Measurement	Limit	Over	Detector	Comment
		MHz	dBm	dB	dBm	dBm	dB		
1	*	2584.025	-32.02	42.14	10.12	33.01	-22.89	peak	

REMARKS:

- (1) Measurement Value = Reading Level + Correct Factor.
- (2) Margin Level = Measurement Value - Limit Value.



Test Mode	LTE Band41	Test Date	2020/10/26
Test Channel	CH40620	Polarization	Horizontal
Temp	22°C	Hum.	66%

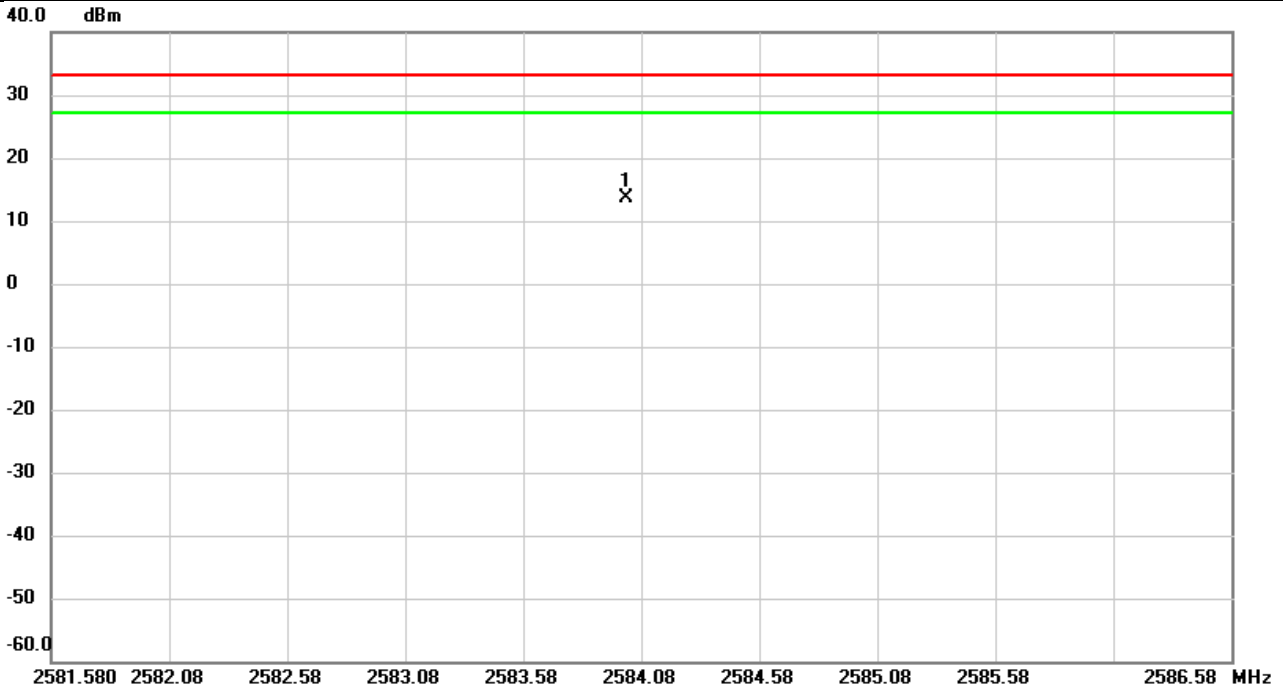

No.	Mk.	Freq.	Reading Level	Correct Factor	Measurement	Limit	Over	Detector	Comment
		MHz	dBm	dB	dBm	dBm	dB		
1	*	2584.015	-28.69	42.22	13.53	33.01	-19.48	peak	

REMARKS:

- (1) Measurement Value = Reading Level + Correct Factor.
- (2) Margin Level = Measurement Value - Limit Value.

Test Mode	LTE Band41	Test Date	2020/10/26
Test Channel	CH41490	Polarization	Vertical
Temp	22°C	Hum.	66%

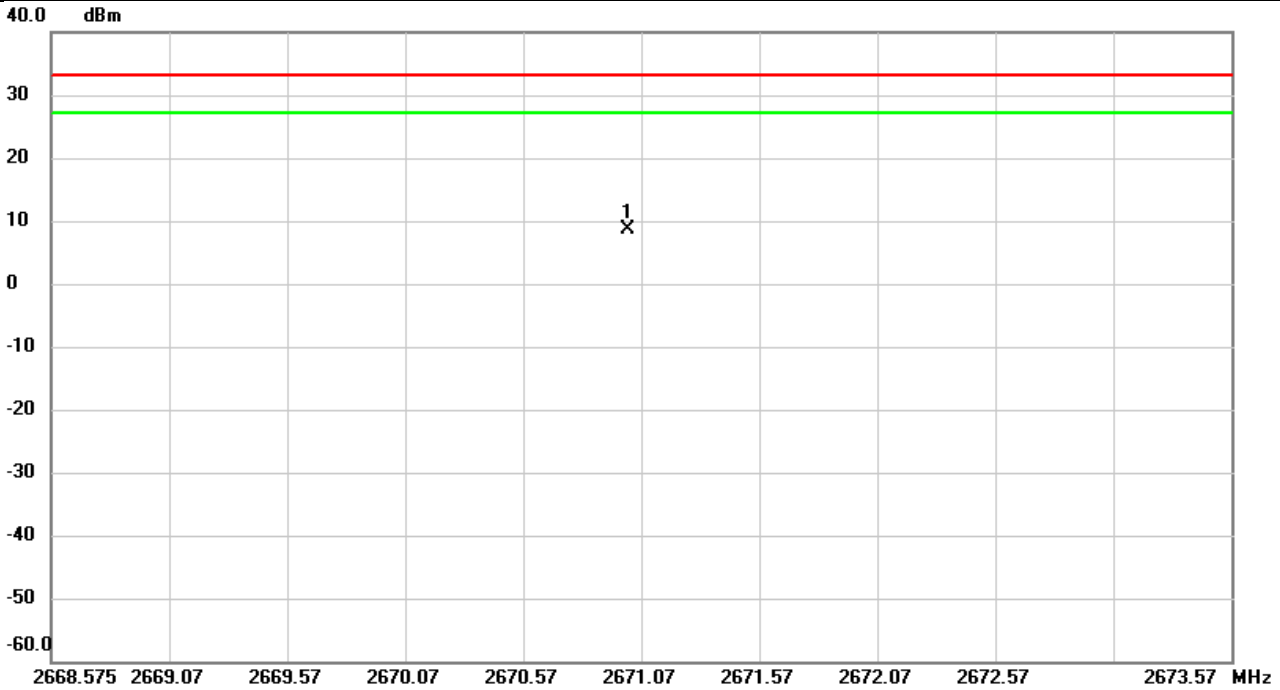

No.	Mk.	Freq.	Reading Level	Correct Factor	Measurement	Limit	Over	Detector	Comment
		MHz	dBm	dB	dBm	dBm	dB		
1	*	2671.020	-33.47	42.18	8.71	33.01	-24.30	peak	

REMARKS:

- (1) Measurement Value = Reading Level + Correct Factor.
- (2) Margin Level = Measurement Value - Limit Value.

Test Mode	LTE Band41	Test Date	2020/10/26
Test Channel	CH41490	Polarization	Horizontal
Temp	22°C	Hum.	66%

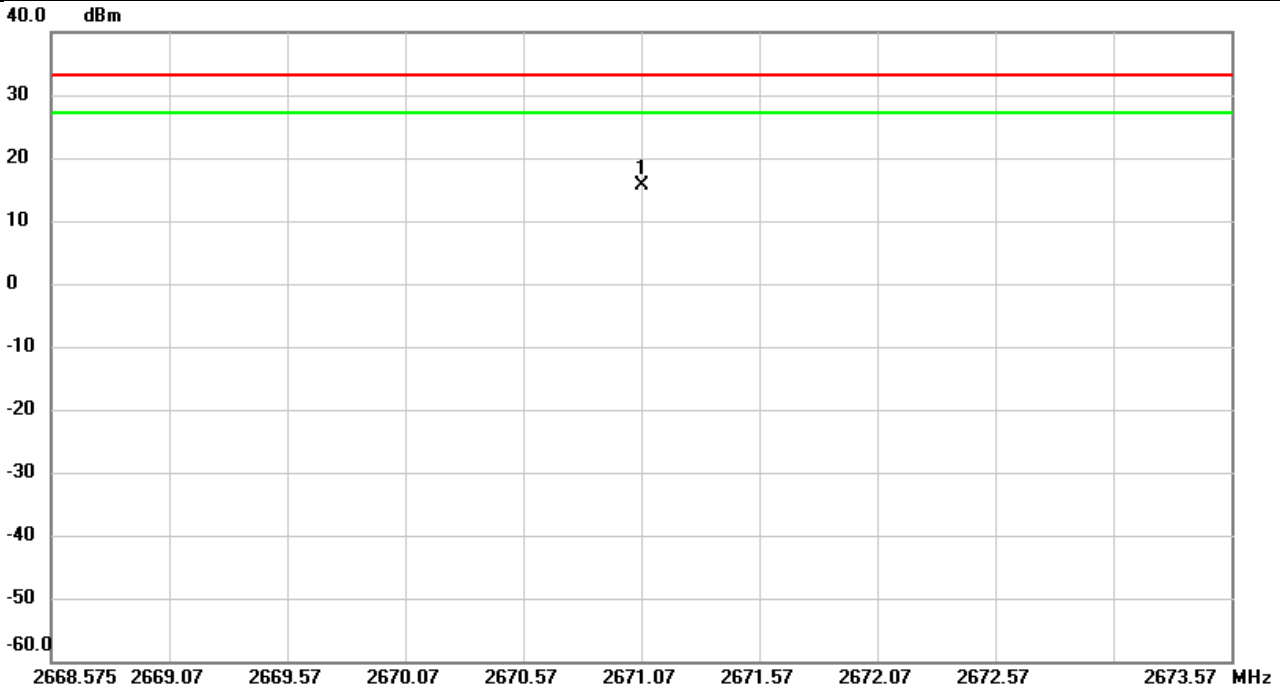

No.	Mk.	Freq.	Reading Level	Correct Factor	Measurement	Limit	Over	Detector	Comment
		MHz	dBm	dB	dBm	dBm	dB		
1	*	2671.080	-26.91	42.63	15.72	33.01	-17.29	peak	

**REMARKS:**

- (1) Measurement Value = Reading Level + Correct Factor.
- (2) Margin Level = Measurement Value - Limit Value.

Test Mode	LTE Band41	Test Date	2020/10/27
Test Channel	CH40620	Polarization	Vertical
Temp	20°C	Hum.	68%

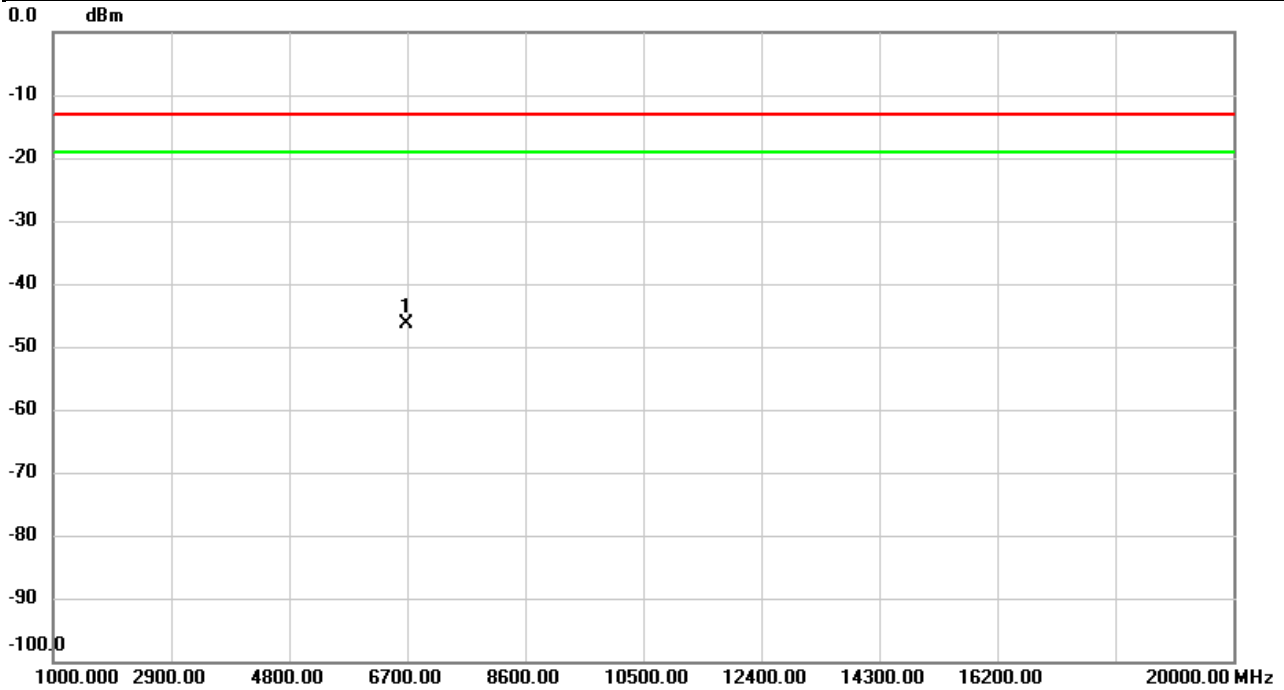

No.	Mk.	Freq.	Reading Level	Correct Factor	Measurement	Limit	Over	Detector	Comment
		MHz	dBm	dB	dBm	dBm	dB		
1	*	6681.000	-51.04	4.55	-46.49	-13.00	-33.49	peak	

REMARKS:

- (1) Measurement Value = Reading Level + Correct Factor.
- (2) Margin Level = Measurement Value - Limit Value.

Test Mode	LTE Band41	Test Date	2020/10/27
Test Channel	CH40620	Polarization	Horizontal
Temp	20°C	Hum.	68%

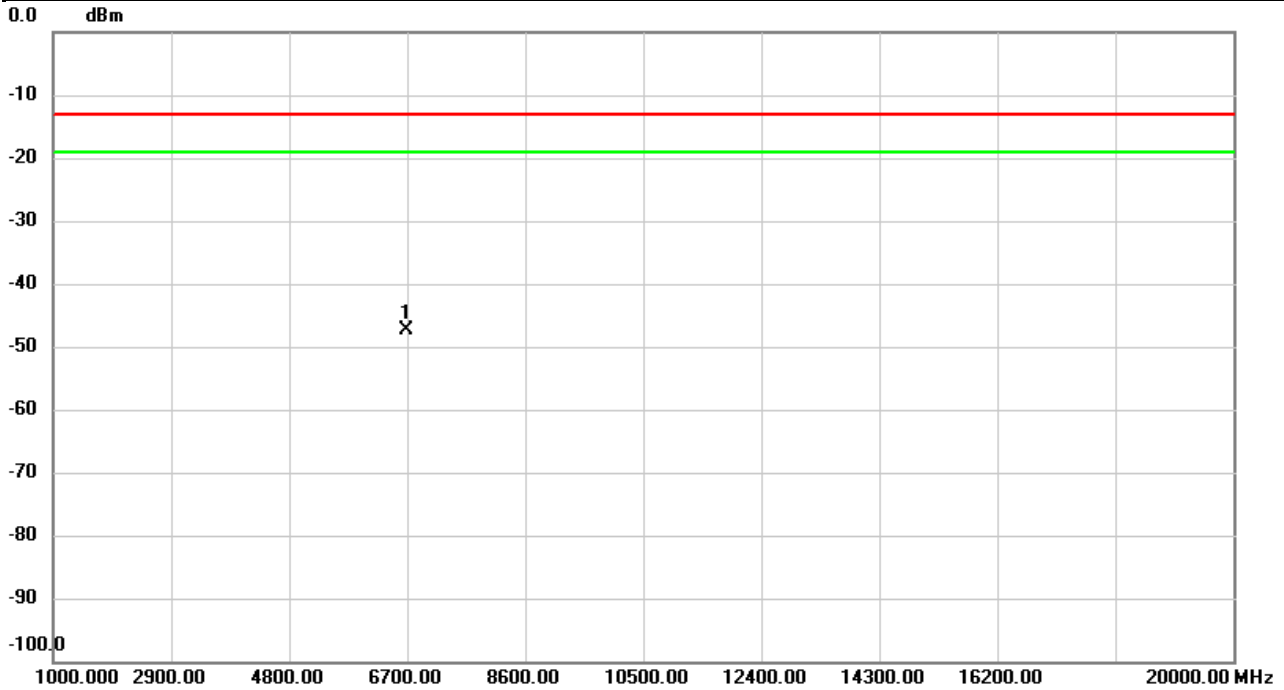

No.	Mk.	Freq. MHz	Reading Level dBm	Correct Factor dB	Measure- ment dBm	Limit dBm	Over dB	Detector	Comment
1	*	6681.000	-52.77	5.51	-47.26	-13.00	-34.26	peak	

**REMARKS:**

- (1) Measurement Value = Reading Level + Correct Factor.
- (2) Margin Level = Measurement Value - Limit Value.

Test Mode	LTE Band66	Test Date	2020/10/27
Test Channel	CH132322	Polarization	Vertical
Temp	20°C	Hum.	68%

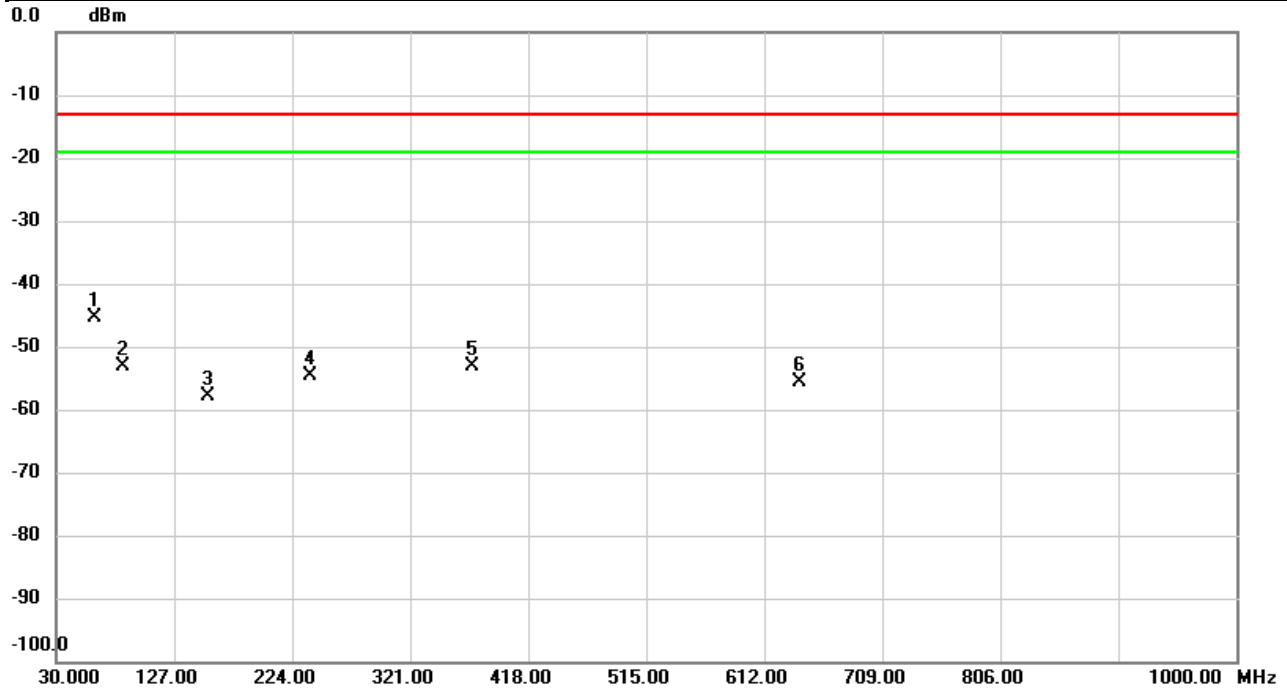

No.	Mk.	Freq. MHz	Reading Level dBm	Correct Factor dB	Measure- ment dBm	Limit dBm	Over dB	Detector	Comment
1	*	61.0400	-43.99	-1.44	-45.43	-13.00	-32.43	peak	
2		84.3200	-51.27	-1.89	-53.16	-13.00	-40.16	peak	
3		154.1600	-61.22	3.31	-57.91	-13.00	-44.91	peak	
4		238.5500	-61.51	6.81	-54.70	-13.00	-41.70	peak	
5		371.4400	-58.07	4.83	-53.24	-13.00	-40.24	peak	
6		641.1000	-68.12	12.60	-55.52	-13.00	-42.52	peak	

**REMARKS:**

- (1) Measurement Value = Reading Level + Correct Factor.
- (2) Margin Level = Measurement Value - Limit Value.

Test Mode	LTE Band66	Test Date	2020/10/27
Test Channel	CH132322	Polarization	Horizontal
Temp	20°C	Hum.	68%

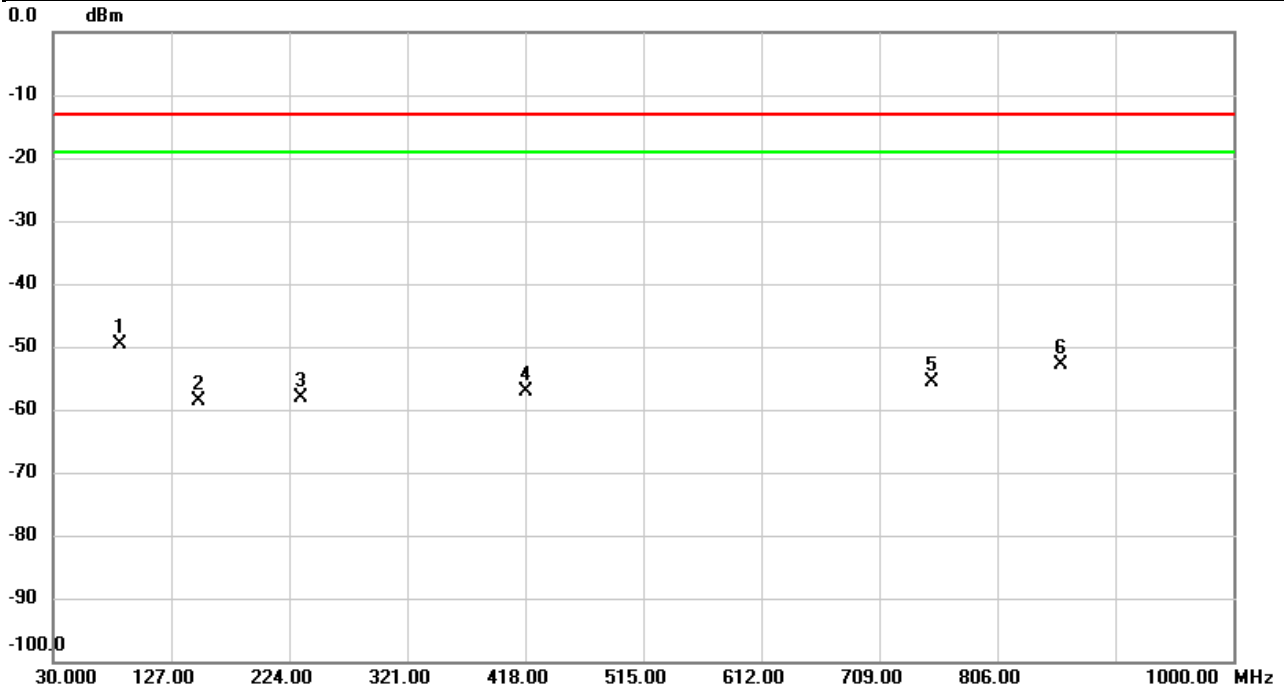

No.	Mk.	Freq.	Reading Level	Correct Factor	Measurement	Limit	Over	Detector	Comment
		MHz	dBm	dB	dBm	dBm	dB		
1	*	84.3200	-54.52	4.85	-49.67	-13.00	-36.67	peak	
2		149.3100	-61.50	2.89	-58.61	-13.00	-45.61	peak	
3		233.7000	-57.56	-0.46	-58.02	-13.00	-45.02	peak	
4		418.9700	-65.71	8.52	-57.19	-13.00	-44.19	peak	
5		751.6800	-68.44	12.84	-55.60	-13.00	-42.60	peak	
6		858.3800	-69.20	16.30	-52.90	-13.00	-39.90	peak	

**REMARKS:**

- (1) Measurement Value = Reading Level + Correct Factor.
- (2) Margin Level = Measurement Value - Limit Value.

Test Mode	LTE Band66	Test Date	2020/10/27
Test Channel	CH132072	Polarization	Vertical
Temp	22°C	Hum.	66%

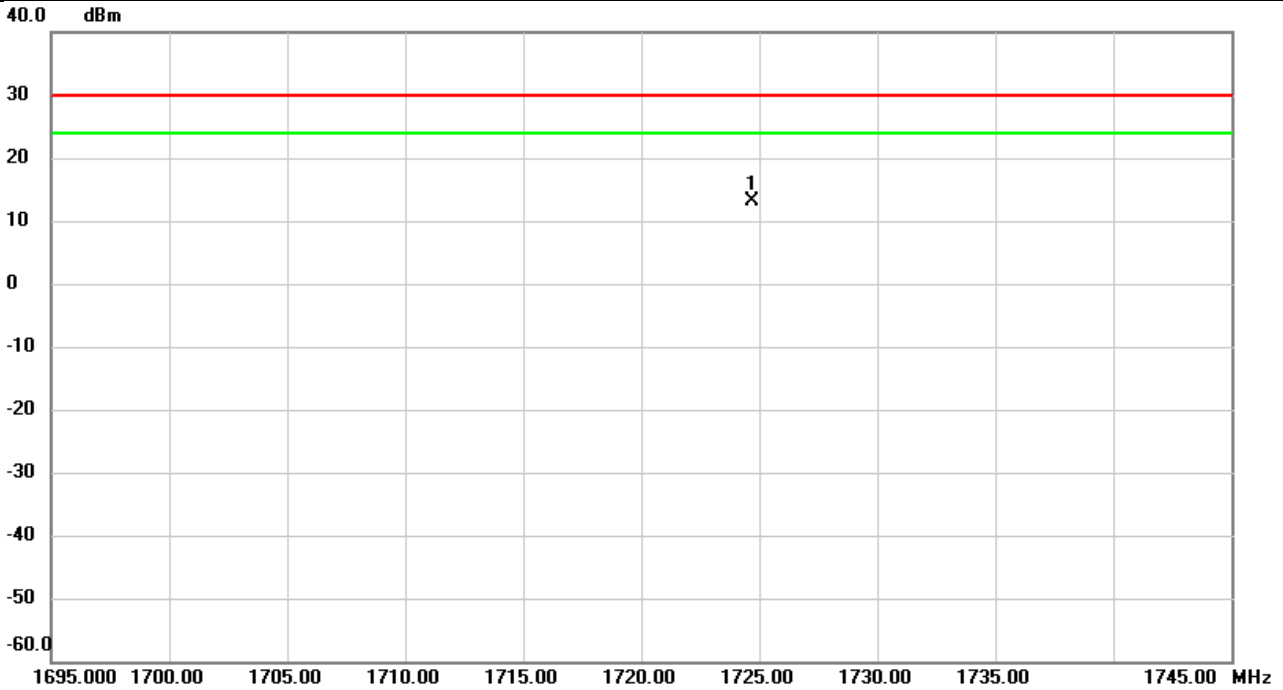

No.	Mk.	Freq.	Reading Level	Correct Factor	Measurement	Limit	Over	Detector	Comment
		MHz	dBm	dB	dBm	dBm	dB		
1	*	1724.700	-26.46	39.53	13.07	30.00	-16.93	peak	

REMARKS:

- (1) Measurement Value = Reading Level + Correct Factor.
- (2) Margin Level = Measurement Value - Limit Value.



Test Mode	LTE Band66	Test Date	2020/10/27
Test Channel	CH132072	Polarization	Horizontal
Temp	22°C	Hum.	66%

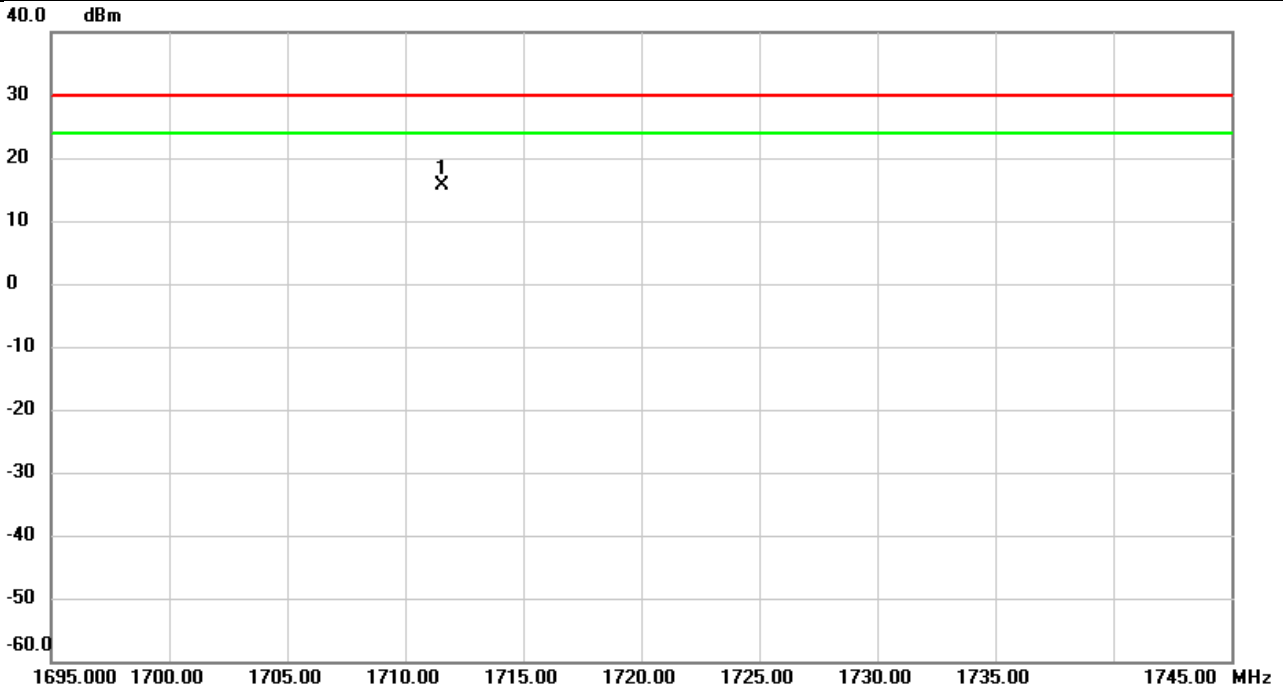

No.	Mk.	Freq.	Reading Level	Correct Factor	Measurement	Limit	Over	Detector	Comment
		MHz	dBm	dB	dBm	dBm	dB		
1	*	1711.600	-24.60	40.11	15.51	30.00	-14.49	peak	

REMARKS:

- (1) Measurement Value = Reading Level + Correct Factor.
- (2) Margin Level = Measurement Value - Limit Value.

Test Mode	LTE Band66	Test Date	2020/10/27
Test Channel	CH132322	Polarization	Vertical
Temp	22°C	Hum.	66%

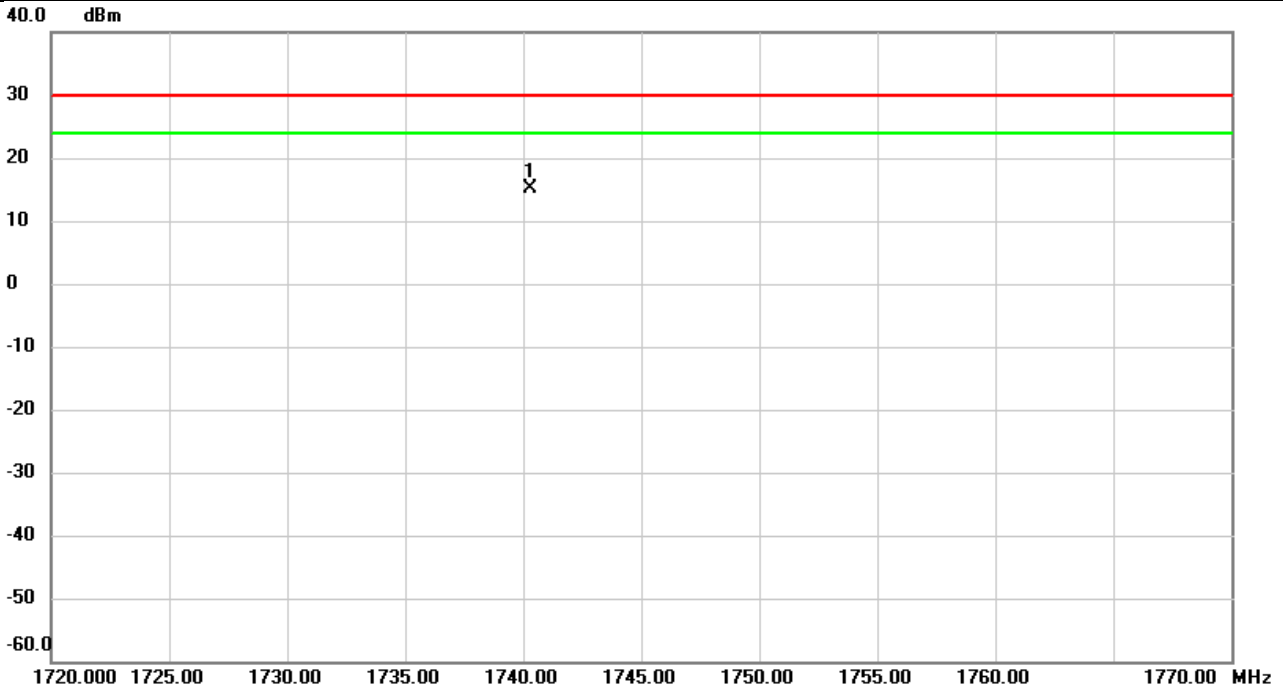

No.	Mk.	Freq.	Reading Level	Correct Factor	Measurement	Limit	Over	Detector	Comment
		MHz	dBm	dB	dBm	dBm	dB		
1	*	1740.300	-24.58	39.60	15.02	30.00	-14.98	peak	

REMARKS:

- (1) Measurement Value = Reading Level + Correct Factor.
- (2) Margin Level = Measurement Value - Limit Value.

Test Mode	LTE Band66	Test Date	2020/10/27
Test Channel	CH132322	Polarization	Horizontal
Temp	22°C	Hum.	66%

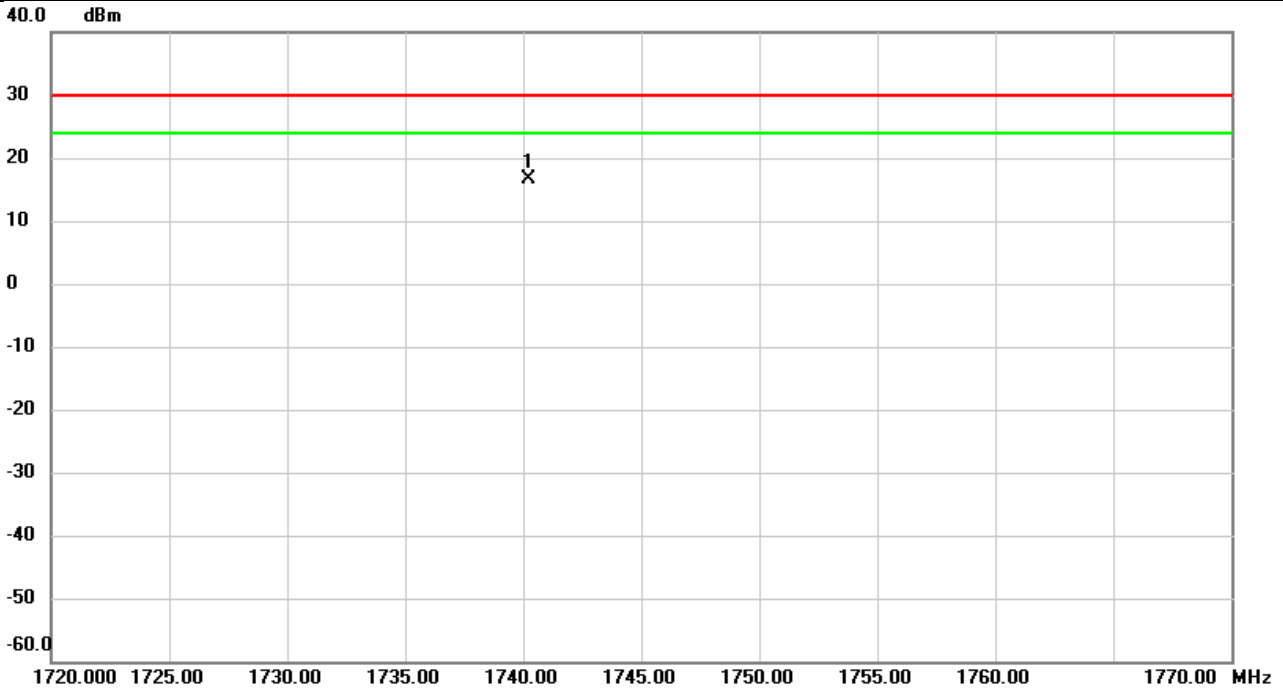

No.	Mk.	Freq.	Reading Level	Correct Factor	Measurement	Limit	Over	Detector	Comment
		MHz	dBm	dB	dBm	dBm	dB		
1	*	1740.200	-23.64	40.21	16.57	30.00	-13.43	peak	

REMARKS:

- (1) Measurement Value = Reading Level + Correct Factor.
- (2) Margin Level = Measurement Value - Limit Value.

Test Mode	LTE Band66	Test Date	2020/10/27
Test Channel	CH132572	Polarization	Vertical
Temp	22°C	Hum.	66%

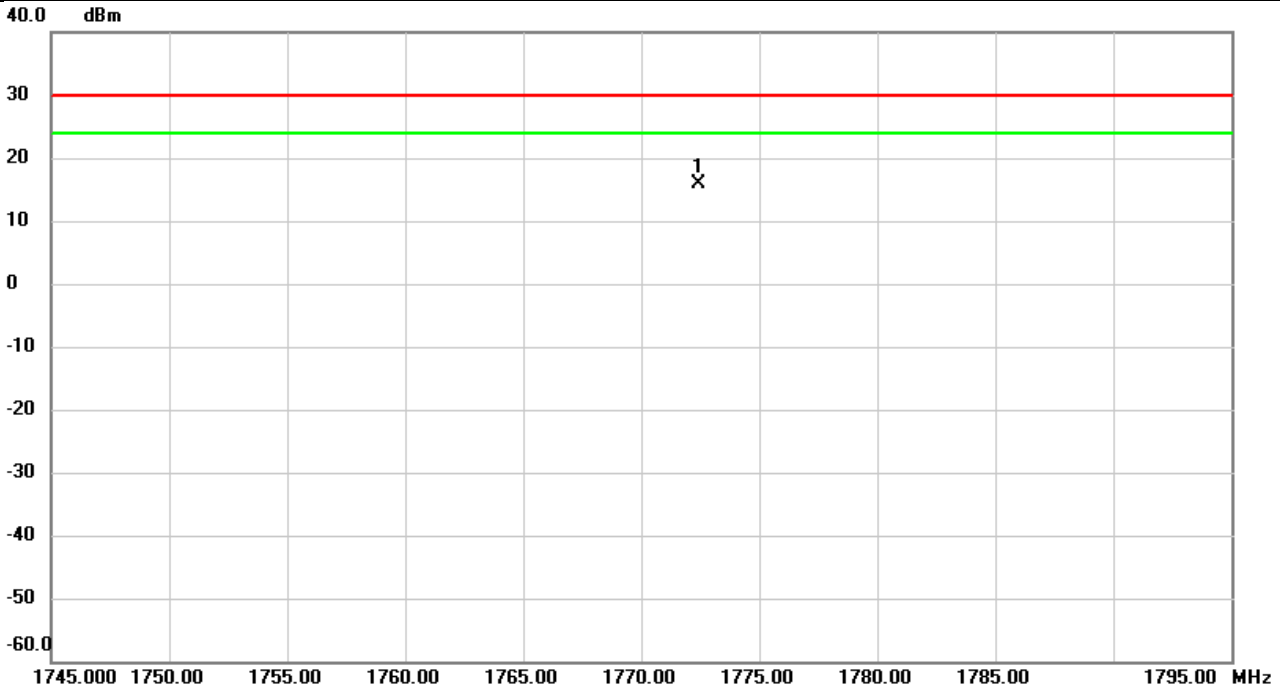

No.	Mk.	Freq. MHz	Reading Level dBm	Correct Factor dB	Measure- ment dBm	Limit dBm	Over dB	Detector	Comment
1	*	1772.450	-23.76	39.74	15.98	30.00	-14.02	peak	

REMARKS:

- (1) Measurement Value = Reading Level + Correct Factor.
- (2) Margin Level = Measurement Value - Limit Value.

Test Mode	LTE Band66	Test Date	2020/10/27
Test Channel	CH132572	Polarization	Horizontal
Temp	22°C	Hum.	66%

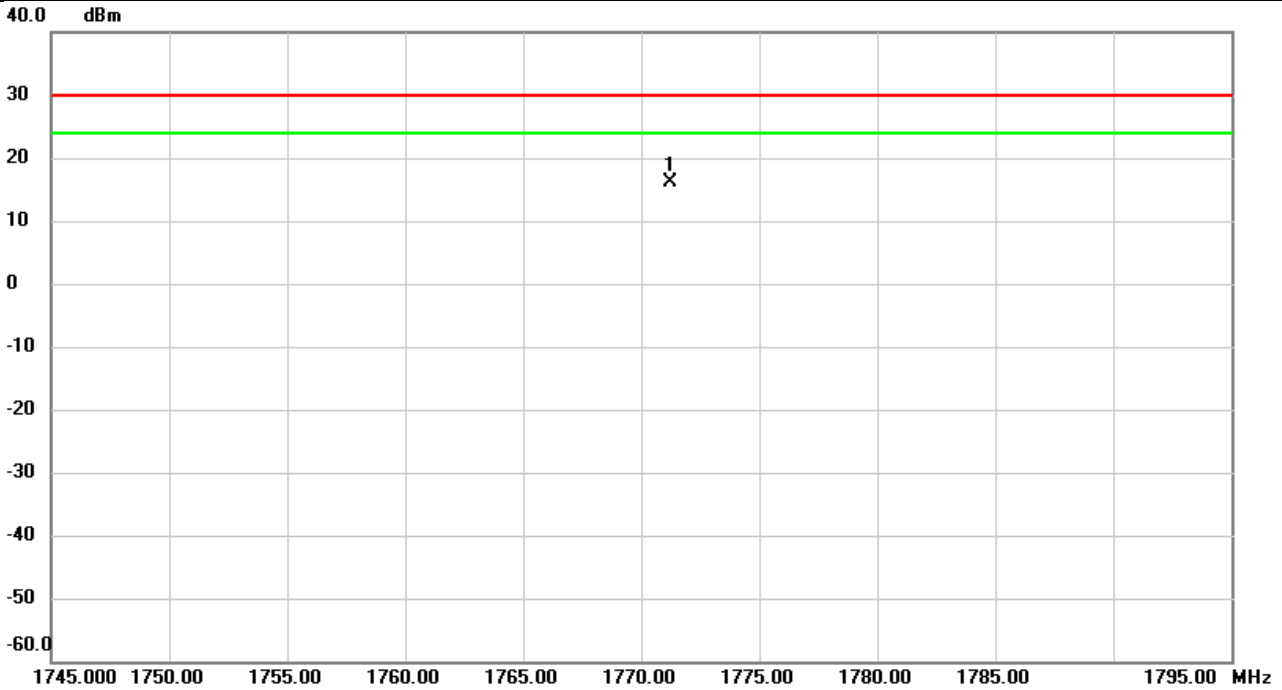

No.	Mk.	Freq. MHz	Reading Level dBm	Correct Factor dB	Measure- ment dBm	Limit dBm	Over dB	Detector	Comment
1	*	1771.200	-24.23	40.33	16.10	30.00	-13.90	peak	

REMARKS:

- (1) Measurement Value = Reading Level + Correct Factor.
- (2) Margin Level = Measurement Value - Limit Value.

Test Mode	LTE Band66	Test Date	2020/10/27
Test Channel	CH132322	Polarization	Vertical
Temp	20°C	Hum.	68%

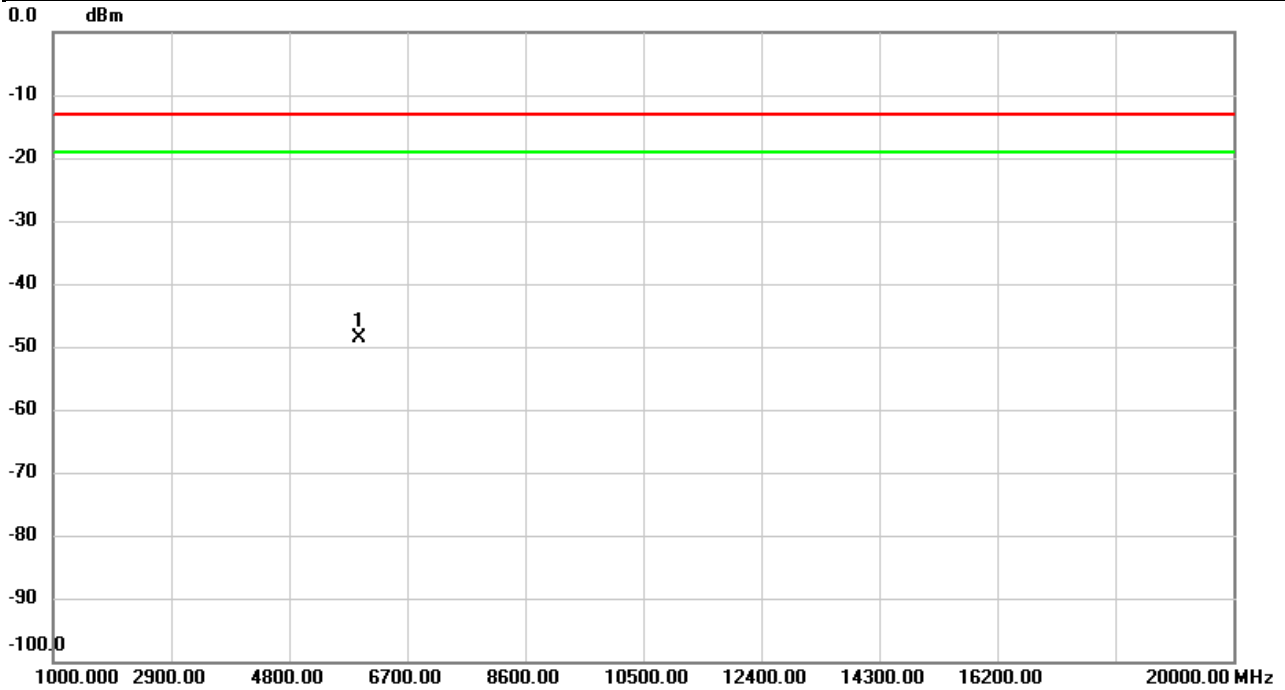

No.	Mk.	Freq.	Reading Level	Correct Factor	Measurement	Limit	Over	Detector	Comment
		MHz	dBm	dB	dBm	dBm	dB		
1	*	5921.000	-51.62	2.93	-48.69	-13.00	-35.69	peak	

**REMARKS:**

- (1) Measurement Value = Reading Level + Correct Factor.
- (2) Margin Level = Measurement Value - Limit Value.

Test Mode	LTE Band66	Test Date	2020/10/27
Test Channel	CH132322	Polarization	Horizontal
Temp	20°C	Hum.	68%

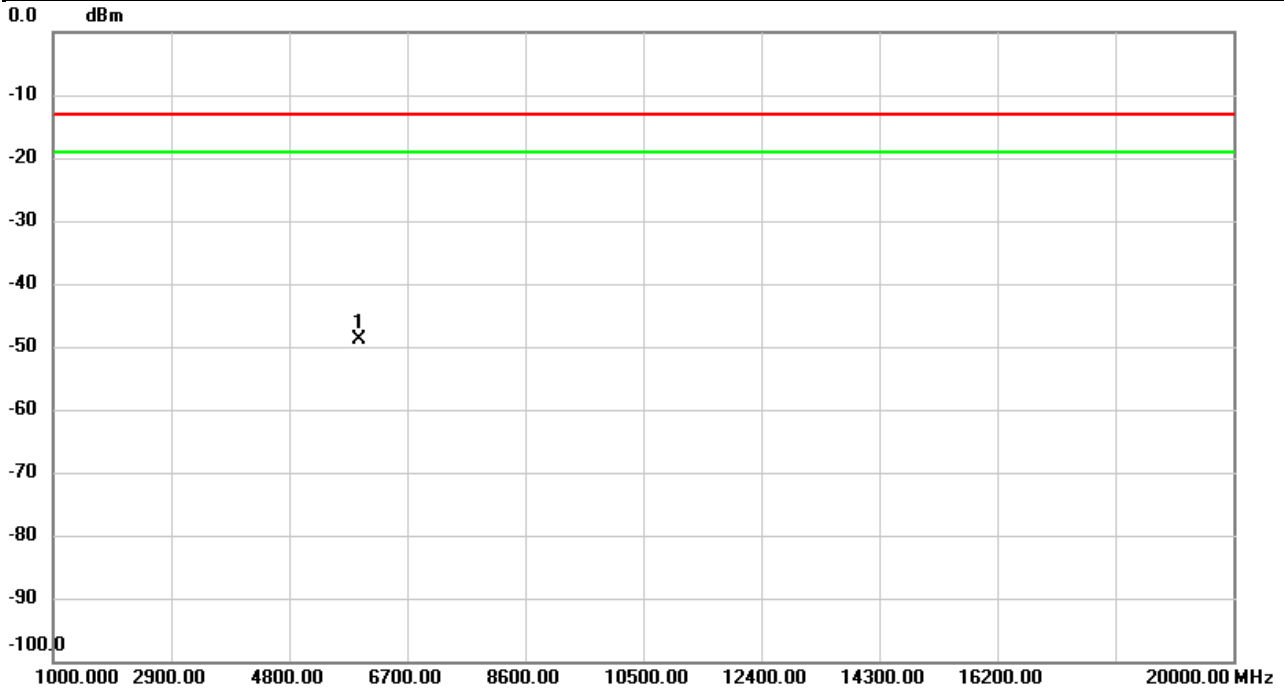

No.	Mk.	Freq.	Reading Level	Correct Factor	Measurement	Limit	Over	Detector	Comment
		MHz	dBm	dB	dBm	dBm	dB		
1	*	5921.000	-52.52	3.54	-48.98	-13.00	-35.98	peak	

**REMARKS:**

- (1) Measurement Value = Reading Level + Correct Factor.
- (2) Margin Level = Measurement Value - Limit Value.

**End of Test Report**