

# FCC Test Report

Product Name	Intel® Dual Band Wireless-AC 8260
Model No	8260D2W
FCC ID.	PD98260D2

Applicant	Intel Mobile Communications France SAS
Address	Le Navigator B 505 route des Lucioles CS 70293 06905 Sophia Antipolis cedex

Date of Receipt	Mar. 30, 2015
Issue Date	May 15, 2015
Report No.	1540115R-RFUSP01V00
Report Version	V1.0



The test results relate only to the samples tested.

The test results shown in the test report are traceable to the national/international standard through the calibration report of the equipment and evaluated measurement uncertainty herein.

This report must not be used to claim product endorsement by TAF or any agency of the government.

The test report shall not be reproduced without the written approval of QuieTek Corporation.

# Test Report

Issue Date: May 15, 2015

Report No.: 1540115R-RFUSP01V00



Product Name	Intel® Dual Band Wireless-AC 8260
Applicant	Intel Mobile Communications France SAS
Address	Le Navigator B 505 route des Lucioles CS 70293 06905 Sophia Antipolis cedex
Manufacturer	Intel Mobile Communications France SAS
Model No.	8260D2W
EUT Rated Voltage	DC 3.3V
EUT Test Voltage	AC 120V/60Hz
Trade Name	Intel
Applicable Standard	FCC CFR Title 47 Part 15 Subpart C: 2013 ANSI C63.4: 2009, ANSI C63.10: 2009 KDB 558074 D01 DTS Meas Guidance v03r02
Test Result	Complied

Documented By : Rita Huang

( Senior Adm. Specialist / Rita Huang )

Tested By : Alan Chen

( Engineer / Alan Chen )

Approved By : [Signature]

( Director / Vincent Lin )

## TABLE OF CONTENTS

Description	Page
<b>1. GENERAL INFORMATION .....</b>	<b>5</b>
1.1. EUT Description .....	5
1.2. Operational Description .....	8
1.3. Tested System Details .....	9
1.4. Configuration of Tested System .....	9
1.5. EUT Exercise Software .....	9
1.6. Test Facility .....	10
<b>2. Conducted Emission.....</b>	<b>11</b>
2.1. Test Equipment .....	11
2.2. Test Setup .....	11
2.3. Limits .....	12
2.4. Test Procedure .....	12
2.5. Uncertainty .....	12
2.6. Test Result of Conducted Emission.....	13
<b>3. Peak Power Output .....</b>	<b>29</b>
3.1. Test Equipment .....	29
3.2. Test Setup .....	29
3.3. Limits .....	29
3.4. Test Procedure .....	30
3.5. Uncertainty .....	30
3.6. Test Result of Peak Power Output.....	31
<b>4. Radiated Emission.....</b>	<b>63</b>
4.1. Test Equipment .....	63
4.2. Test Setup .....	64
4.3. Limits .....	65
4.4. Test Procedure .....	66
4.5. Uncertainty .....	66
4.6. Test Result of Radiated Emission.....	67
<b>5. RF antenna conducted test.....</b>	<b>171</b>
5.1. Test Equipment .....	171
5.2. Test Setup .....	171
5.3. Limits .....	171
5.4. Test Procedure .....	172
5.5. Uncertainty .....	172
5.6. Test Result of RF antenna conducted test.....	173
<b>6. Band Edge .....</b>	<b>247</b>
6.1. Test Equipment .....	247
6.2. Test Setup .....	248
6.3. Limits .....	248
6.4. Test Procedure .....	249
6.5. Uncertainty .....	249
6.6. Test Result of Band Edge .....	250

<b>7.</b>	<b>Occupied Bandwidth .....</b>	<b>482</b>
7.1.	Test Equipment .....	482
7.2.	Test Setup .....	482
7.3.	Limits .....	482
7.4.	Test Procedure .....	482
7.5.	Uncertainty .....	482
7.6.	Test Result of Occupied Bandwidth .....	483
<b>8.</b>	<b>Power Density .....</b>	<b>561</b>
8.1.	Test Equipment .....	561
8.2.	Test Setup .....	561
8.3.	Limits .....	561
8.4.	Test Procedure .....	561
8.5.	Uncertainty .....	561
8.6.	Test Result of Power Density .....	562
<b>9.</b>	<b>EMI Reduction Method During Compliance Testing .....</b>	<b>640</b>

Attachment 1: EUT Test Photographs

Attachment 2: EUT Detailed Photographs

## 1. GENERAL INFORMATION

### 1.1. EUT Description

Product Name	Intel® Dual Band Wireless-AC 8260
Trade Name	Intel
Model No.	8260D2W
FCC ID.	PD98260D2
Frequency Range	802.11b/g/n-20MHz:2412-2467MHz,802.11n-40MHz:2422-2457MHz 802.11a/n-20MHz:5745-5825MHz ,802.11n-40MHz:5755-5795MHz 802.11ac-80MHz: 5775MHz,
Number of Channels	802.11b/g/n-20MHz: 12, n-40MHz: 8 802.11a/n-20MHz: 5, n-40MHz: 2 802.11ac-80MHz: 1
Data Speed	802.11b: 1-11Mbps, 802.11a/g: 6-54Mbps, 802.11n: up to 300Mbps 802.11ac-80MHz: up to 866.7MHz
Channel separation	802.11b/g/n-20MHz: 5 MHz, 802.11a/n-20MHz: 20MHz 802.11n-40MHz: 40MHz, 802.11ac-80MHz: 80MHz
Type of Modulation	802.11b:DSSS, DBPSK, DQPSK, CCK 802.11a/g/n/ac: OFDM, BPSK, QPSK, 16QAM, 64QAM, 256QAM
Antenna Type	PIFA Antenna
Antenna Gain	Refer to the table “Antenna List”
Channel Control	Auto

#### Antenna List

No.	Manufacturer	Part No.	Antenna Type	Peak Gain
1	SkyCross	N/A (Main) N/A (Aux )	PIFA	3.24 dBi in 2.4GHz 4.97 dBi in 5.725~5.850GHz

Note: The antenna of EUT is conform to FCC 15.203

802.11b/g/n-20MHz Center Frequency of Each Channel:

Channel	Frequency	Channel	Frequency	Channel	Frequency	Channel	Frequency
Channel 01:	2412 MHz	Channel 02:	2417 MHz	Channel 03:	2422 MHz	Channel 04:	2427 MHz
Channel 05:	2432 MHz	Channel 06:	2437 MHz	Channel 07:	2442 MHz	Channel 08:	2447 MHz
Channel 09:	2452 MHz	Channel 10:	2457 MHz	Channel 11:	2462 MHz	Channel 12:	2467 MHz

802.11a/n-20MHz Center Working Frequency of Each Channel:

Channel	Frequency	Channel	Frequency	Channel	Frequency	Channel	Frequency
Channel 149:	5745 MHz	Channel 153:	5765 MHz	Channel 157:	5785 MHz	Channel 161:	5805 MHz
Channel 165:	5825 MHz						

802.11n-40MHz (2.4G Band) Center Working Frequency of Each Channel:

Channel	Frequency	Channel	Frequency	Channel	Frequency	Channel	Frequency
Channel 3:	2422 MHz	Channel 4:	2427 MHz	Channel 5:	2432 MHz	Channel 6:	2437 MHz
Channel 7:	2442 MHz	Channel 8:	2447 MHz	Channel 9:	2452 MHz	Channel 10:	2457 MHz

802.11n-40MHz (5G Band) Center Working Frequency of Each Channel:

Channel	Frequency	Channel	Frequency
Channel 151:	5755 MHz	Channel 159:	5795 MHz

802.11ac-80MHz Center Working Frequency of Each Channel:

Channel	Frequency
Channel 155:	5775 MHz

**Duty Cycle**

Formula:

$$\text{Duty cycle} = \text{Ton} / (\text{Ton} + \text{Toff})$$

$$\text{Duty Factor} = 10 \text{ Log} (1/\text{Duty Cycle})$$

Results:

2.4GHz band	Duty Cycle	Duty Factor (dB)	5GHz band	Duty Cycle	Duty Factor (dB)
802.11b	0.982	0.079	802.11a	0.982	0.079
802.11g	0.988	0.052	802.11n-20	0.98	0.088
802.11n-20	0.983	0.074	802.11n-40	0.966	0.150
802.11n-40	0.94	0.269	802.11ac-80	0.799	0.975

Note:

1. This device is an Intel® Dual Band Wireless-AC 8260 with a built-in 2.4GHz and 5GHz WLAN transceiver.
2. Regarding to the operation frequency, the lowest, middle and highest frequency are selected to perform the test.
3. These tests are conducted on a sample for the purpose of demonstrating compliance of 802.11a/b/g/n transmitter with Part 15 Subpart C Paragraph 15.247 of spread spectrum devices.

Test Mode:	Mode 1 SISO A: Transmit (802.11b 1Mbps)
	Mode 1 SISO A: Transmit (802.11g 6Mbps)
	Mode 1 SISO A: Transmit - 802.11a 6Mbps
	Mode 1 SISO A: Transmit - 802.11n-20BW_7.2Mbps(2.4G Band)
	Mode 1 SISO A: Transmit - 802.11n-40BW_15Mbps(2.4G Band)
	Mode 1 SISO A: Transmit - 802.11n-20BW_7.2Mbps(5G Band)
	Mode 1 SISO A: Transmit - 802.11n-40BW_15Mbps(5G Band)
	Mode 1 SISO A: Transmit - 802.11ac-80BW_32.5Mbps(5G Band)
	Mode 2 SISO B: Transmit (802.11b 1Mbps)
	Mode 2 SISO B: Transmit (802.11g 6Mbps)
	Mode 2 SISO B: Transmit - 802.11a 6Mbps
	Mode 2 SISO B: Transmit - 802.11n-20BW_7.2Mbps(2.4G Band)
	Mode 2 SISO B: Transmit - 802.11n-40BW_15Mbps(2.4G Band)
	Mode 2 SISO B: Transmit - 802.11n-20BW_7.2Mbps(5G Band)
	Mode 2 SISO B: Transmit - 802.11n-40BW_15Mbps(5G Band)
	Mode 2 SISO B: Transmit - 802.11ac-80BW_32.5Mbps(5G Band)
	Mode 3 MIMO: Transmit - 802.11n-20BW_14.4Mbps(2.4G Band)
	Mode 3 MIMO: Transmit - 802.11n-40BW_30Mbps(2.4G Band)
	Mode 3 MIMO: Transmit - 802.11n-20BW_14.4Mbps(5G Band)
	Mode 3 MIMO: Transmit - 802.11n-40BW_30Mbps(5G Band)
	Mode 3 MIMO: Transmit - 802.11ac-80BW_65Mbps(5G Band)
	Mode 4 Beamforming: Transmit - 802.11n-20BW_14.4Mbps(2.4G Band)
	Mode 4 Beamforming: Transmit - 802.11n-40BW_30Mbps(2.4G Band)
	Mode 4 Beamforming: Transmit - 802.11n-20BW_14.4Mbps(5G Band)
	Mode 4 Beamforming: Transmit - 802.11n-40BW_30Mbps(5G Band)
	Mode 4 Beamforming: Transmit - 802.11ac-80BW_65Mbps(5G Band)

### 1.3. Tested System Details

The types for all equipment, plus descriptions of all cables used in the tested system (including inserted cards) are:

	Product	Manufacturer	Model No.	Serial No.	Power Cord
1	Notebook PC	DELL	N/A	N/A	Non-Shielded, 1.8m
2	Test Fixture	Intel	N/A	N/A	N/A

Signal Cable Type	Signal cable Description
A	Test Fixture Cable
	Non-Shielded, 1.0m

### 1.4. Configuration of Tested System

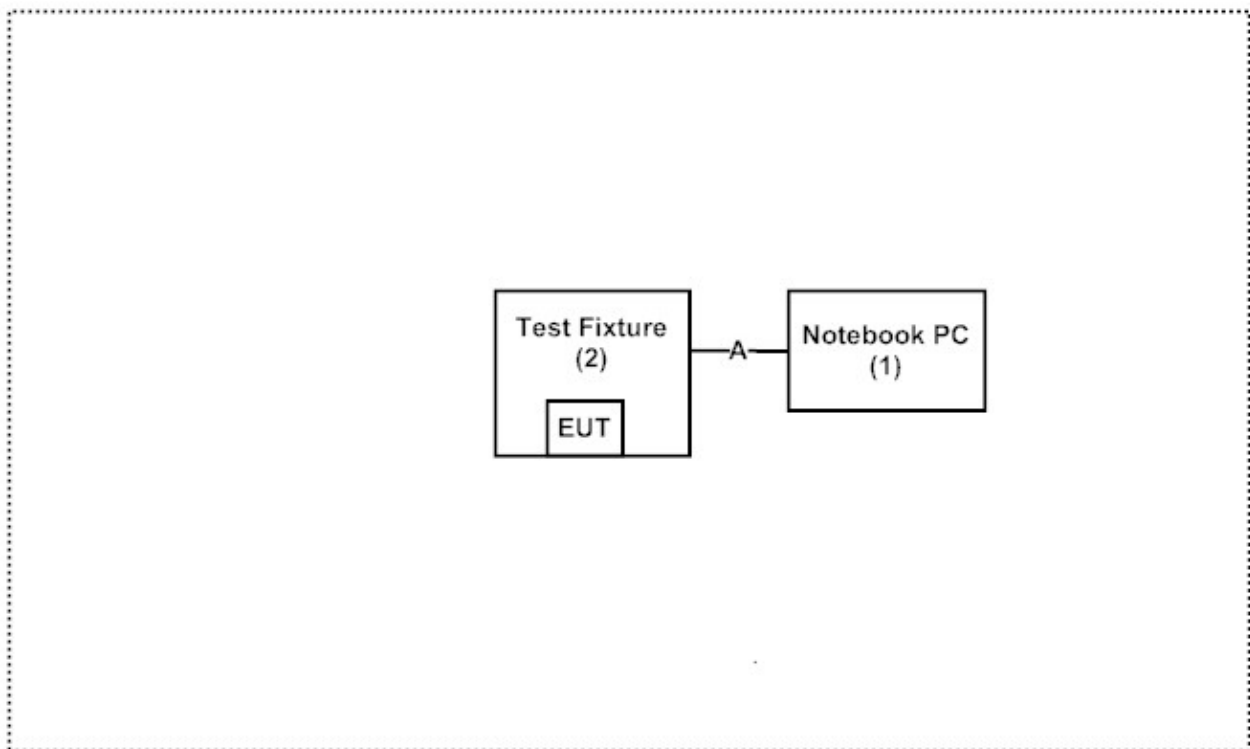

### 1.5. EUT Exercise Software

- (1) Setup the EUT as shown in Section 1.3.
- (2) Execute software “DRTU (Ver 1.8.1-01253)” on the EUT.
- (3) Configure the test mode, the test channel, and the data rate.
- (4) Press “OK” to start the continuous Transmit.
- (5) Verify that the EUT works properly.



**1.6. Test Facility**

Ambient conditions in the laboratory:

Items	Required (IEC 68-1)	Actual
Temperature (°C)	15-35	20-35
Humidity (%RH)	25-75	50-65
Barometric pressure (mbar)	860-1060	950-1000

The related certificate for our laboratories about the test site and management system can be downloaded from Quietek Corporation's Web Site : <http://www.quietek.com/chinese/about/certificates.aspx?bval=5>  
The address and introduction of Quietek Corporation's laboratories can be founded in our Web site : <http://www.quietek.com/>

Site Description: File on  
Federal Communications Commission  
FCC Engineering Laboratory  
7435 Oakland Mills Road  
Columbia, MD 21046  
Registration Number: 92195

Site Name: Quietek Corporation  
Site Address: No.5-22, Ruishukeng,  
Linkou Dist. New Taipei City 24451,  
Taiwan, R.O.C.  
TEL: 886-2-8601-3788 / FAX : 886-2-8601-3789  
E-Mail : [service@quietek.com](mailto:service@quietek.com)

FCC Accreditation Number: TW1014

## 2. Conducted Emission

### 2.1. Test Equipment

	Equipment	Manufacturer	Model No. / Serial No.	Last Cal.	Remark
X	Test Receiver	R & S	ESCS 30 / 825442/018	Sep., 2014	
X	Artificial Mains Network	R & S	ENV4200 / 848411/10	Feb., 2015	Peripherals
X	LISN	R & S	ESH3-Z5 / 825562/002	Feb., 2015	EUT
	DC LISN	Schwarzbeck	8226 / 176	Mar., 2015	EUT
X	Pulse Limiter	R & S	ESH3-Z2 / 357.8810.52	Feb., 2015	
	No.1 Shielded Room				

Note:

1. All equipments are calibrated every one year.
2. The test instruments marked by "X" are used to measure the final test results.

### 2.2. Test Setup

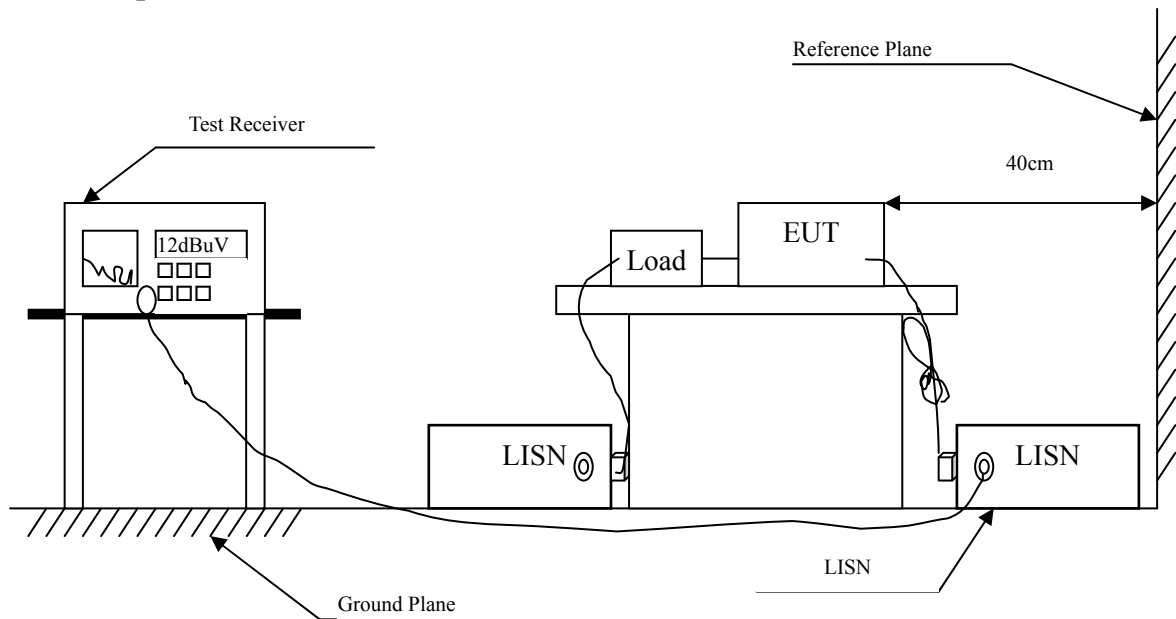

**2.3. Limits**

<b>FCC Part 15 Subpart C Paragraph 15.207 (dBuV) Limit</b>		
Frequency MHz	Limits	
	QP	AVG
0.15 - 0.50	66-56	56-46
0.50-5.0	56	46
5.0 - 30	60	50

**2.4. Test Procedure**

The EUT and simulators are connected to the main power through a line impedance stabilization network (L.I.S.N.). This provides a 50 ohm /50uH coupling impedance for the measuring equipment. The peripheral devices are also connected to the main power through a LISN that provides a 50ohm /50uH coupling impedance with 50ohm termination. (Please refers to the block diagram of the test setup and photographs.)

Both sides of A.C. line are checked for maximum conducted interference. In order to find the maximum emission, the relative positions of equipment and all of the interface cables must be changed according to ANSI C63.4: 2009 on conducted measurement.

Conducted emissions were invested over the frequency range from 0.15MHz to 30MHz using a receiver bandwidth of 9kHz.

**2.5. Uncertainty**

± 2.26 dB

**2.6. Test Result of Conducted Emission**

Product : Intel® Dual Band Wireless-AC 8260  
 Test Item : Conducted Emission Test  
 Power Line : Line 1  
 Test Mode : Mode 1 SISO A: Transmit - 802.11n-40BW\_15Mbps(2.4G Band) (2437MHz)

Frequency MHz	Correct Factor dB	Reading Level dBuV	Measurement Level dBuV	Margin dB	Limit dBuV
<b>Line 1</b>					
<b>Quasi-Peak</b>					
0.181	9.662	33.540	43.202	-21.912	65.114
0.212	9.661	30.860	40.521	-23.708	64.229
0.576	9.681	30.670	40.351	-15.649	56.000
1.587	9.746	20.780	30.526	-25.474	56.000
2.337	9.783	21.950	31.733	-24.267	56.000
4.244	9.836	14.030	23.866	-32.134	56.000
<b>Average</b>					
0.181	9.662	23.550	33.212	-21.902	55.114
0.212	9.661	22.200	31.861	-22.368	54.229
0.576	9.681	26.970	36.651	-9.349	46.000
1.587	9.746	15.350	25.096	-20.904	46.000
2.337	9.783	14.480	24.263	-21.737	46.000
4.244	9.836	4.730	14.566	-31.434	46.000

Note:

1. All Reading Levels are Quasi-Peak and average value.
2. “” means the worst emission level.
3. Measurement Level = Reading Level + Correct Factor

Product : Intel® Dual Band Wireless-AC 8260  
 Test Item : Conducted Emission Test  
 Power Line : Line 2  
 Test Mode : Mode 1 SISO A: Transmit - 802.11n-40BW\_15Mbps(2.4G Band) (2437MHz)

Frequency MHz	Correct Factor dB	Reading Level dBuV	Measurement Level dBuV	Margin dB	Limit dBuV
<b>Line 2</b>					
<b>Quasi-Peak</b>					
0.154	9.670	35.750	45.420	-20.466	65.886
0.185	9.661	31.000	40.661	-24.339	65.000
0.548	9.679	31.520	41.199	-14.801	56.000
1.576	9.745	19.830	29.575	-26.425	56.000
2.322	9.783	23.020	32.803	-23.197	56.000
18.334	10.167	14.350	24.517	-35.483	60.000
<b>Average</b>					
0.154	9.670	22.310	31.980	-23.906	55.886
0.185	9.661	18.960	28.621	-26.379	55.000
0.548	9.679	29.420	39.099	-6.901	46.000
1.576	9.745	12.970	22.715	-23.285	46.000
2.322	9.783	14.600	24.383	-21.617	46.000
18.334	10.167	4.320	14.487	-35.513	50.000

Note:

1. All Reading Levels are Quasi-Peak and average value.
2. "■" means the worst emission level.
3. Measurement Level = Reading Level + Correct Factor

Product : Intel® Dual Band Wireless-AC 8260  
 Test Item : Conducted Emission Test  
 Power Line : Line 1  
 Test Mode : Mode 1 SISO A: Transmit - 802.11ac-80BW\_32.5Mbps(5G Band) (5775MHz)

Frequency MHz	Correct Factor dB	Reading Level dBuV	Measurement Level dBuV	Margin dB	Limit dBuV
<b>Line 1</b>					
<b>Quasi-Peak</b>					
0.150	9.671	37.200	46.871	-19.129	66.000
0.177	9.663	31.310	40.973	-24.256	65.229
0.209	9.661	29.790	39.451	-24.863	64.314
0.568	9.680	29.690	39.370	-16.630	56.000
2.345	9.783	20.130	29.913	-26.087	56.000
18.904	10.052	12.050	22.102	-37.898	60.000
<b>Average</b>					
0.150	9.671	30.480	40.151	-15.849	56.000
0.177	9.663	22.920	32.583	-22.646	55.229
0.209	9.661	22.410	32.071	-22.243	54.314
0.568	9.680	20.990	30.670	-15.330	46.000
2.345	9.783	10.320	20.103	-25.897	46.000
18.904	10.052	5.580	15.632	-34.368	50.000

Note:

1. All Reading Levels are Quasi-Peak and average value.
2. “ “ means the worst emission level.
3. Measurement Level = Reading Level + Correct Factor

Product : Intel® Dual Band Wireless-AC 8260  
 Test Item : Conducted Emission Test  
 Power Line : Line 2  
 Test Mode : Mode 1 SISO A: Transmit - 802.11ac-80BW\_32.5Mbps(5G Band) (5775MHz)

Frequency MHz	Correct Factor dB	Reading Level dBuV	Measurement Level dBuV	Margin dB	Limit dBuV
<b>Line 2</b>					
<b>Quasi-Peak</b>					
0.150	9.671	36.650	46.321	-19.679	66.000
0.181	9.662	32.960	42.622	-22.492	65.114
0.541	9.679	28.470	38.149	-17.851	56.000
0.568	9.680	28.610	38.290	-17.710	56.000
2.361	9.783	21.160	30.943	-25.057	56.000
19.377	10.186	11.950	22.136	-37.864	60.000
<b>Average</b>					
0.150	9.671	28.540	38.211	-17.789	56.000
0.181	9.662	16.730	26.392	-28.722	55.114
0.541	9.679	24.960	34.639	-11.361	46.000
0.568	9.680	23.240	32.920	-13.080	46.000
2.361	9.783	11.660	21.443	-24.557	46.000
19.377	10.186	2.690	12.876	-37.124	50.000

Note:

1. All Reading Levels are Quasi-Peak and average value.
2. “ “ means the worst emission level.
3. Measurement Level = Reading Level + Correct Factor

Product : Intel® Dual Band Wireless-AC 8260  
 Test Item : Conducted Emission Test  
 Power Line : Line 1  
 Test Mode : Mode 2 SISO B: Transmit - 802.11n-40BW\_15Mbps(2.4G Band) (2437MHz)

Frequency MHz	Correct Factor dB	Reading Level dBuV	Measurement Level dBuV	Margin dB	Limit dBuV
<b>Line 1</b>					
<b>Quasi-Peak</b>					
0.185	9.661	32.560	42.221	-22.779	65.000
0.216	9.661	28.470	38.131	-25.983	64.114
0.548	9.679	31.390	41.069	-14.931	56.000
1.580	9.746	20.000	29.746	-26.254	56.000
2.373	9.784	20.290	30.074	-25.926	56.000
19.627	10.058	11.050	21.108	-38.892	60.000
<b>Average</b>					
0.185	9.661	21.870	31.531	-23.469	55.000
0.216	9.661	19.060	28.721	-25.393	54.114
0.548	9.679	30.020	39.699	-6.301	46.000
1.580	9.746	16.780	26.526	-19.474	46.000
2.373	9.784	11.370	21.154	-24.846	46.000
19.627	10.058	4.120	14.178	-35.822	50.000

Note:

1. All Reading Levels are Quasi-Peak and average value.
2. “ “ means the worst emission level.
3. Measurement Level = Reading Level + Correct Factor



Product : Intel® Dual Band Wireless-AC 8260  
 Test Item : Conducted Emission Test  
 Power Line : Line 2  
 Test Mode : Mode 2 SISO B: Transmit - 802.11n-40BW\_15Mbps(2.4G Band) (2437MHz)

Frequency MHz	Correct Factor dB	Reading Level dBuV	Measurement Level dBuV	Margin dB	Limit dBuV
<b>Line 2</b>					
<b>Quasi-Peak</b>					
0.150	9.671	35.970	45.641	-20.359	66.000
0.185	9.661	30.990	40.651	-24.349	65.000
0.552	9.680	29.100	38.780	-17.220	56.000
1.978	9.767	20.170	29.937	-26.063	56.000
2.369	9.784	20.830	30.614	-25.386	56.000
19.252	10.185	12.620	22.805	-37.195	60.000
<b>Average</b>					
0.150	9.671	17.250	26.921	-29.079	56.000
0.185	9.661	17.590	27.251	-27.749	55.000
0.552	9.680	21.390	31.070	-14.930	46.000
1.978	9.767	12.100	21.867	-24.133	46.000
2.369	9.784	13.690	23.474	-22.526	46.000
19.252	10.185	3.950	14.135	-35.865	50.000

Note:

1. All Reading Levels are Quasi-Peak and average value.
2. "■" means the worst emission level.
3. Measurement Level = Reading Level + Correct Factor

Product : Intel® Dual Band Wireless-AC 8260  
 Test Item : Conducted Emission Test  
 Power Line : Line 1  
 Test Mode : Mode 2 SISO B: Transmit - 802.11ac-80BW\_32.5Mbps(5G Band) (5775MHz)

Frequency MHz	Correct Factor dB	Reading Level dBuV	Measurement Level dBuV	Margin dB	Limit dBuV
<b>Line 1</b>					
<b>Quasi-Peak</b>					
0.181	9.662	33.990	43.652	-21.462	65.114
0.212	9.661	31.230	40.891	-23.338	64.229
0.240	9.663	25.890	35.553	-27.876	63.429
0.556	9.680	27.050	36.730	-19.270	56.000
2.337	9.783	20.830	30.613	-25.387	56.000
19.638	10.058	10.950	21.008	-38.992	60.000
<b>Average</b>					
0.181	9.662	27.390	37.052	-18.062	55.114
0.212	9.661	21.190	30.851	-23.378	54.229
0.240	9.663	15.470	25.133	-28.296	53.429
0.556	9.680	14.240	23.920	-22.080	46.000
2.337	9.783	17.520	27.303	-18.697	46.000
19.638	10.058	2.410	12.468	-37.532	50.000

Note:

1. All Reading Levels are Quasi-Peak and average value.
2. “ “ means the worst emission level.
3. Measurement Level = Reading Level + Correct Factor

Product : Intel® Dual Band Wireless-AC 8260  
 Test Item : Conducted Emission Test  
 Power Line : Line 2  
 Test Mode : Mode 2 SISO B: Transmit - 802.11ac-80BW\_32.5Mbps(5G Band) (5775MHz)

Frequency MHz	Correct Factor dB	Reading Level dBuV	Measurement Level dBuV	Margin dB	Limit dBuV
<b>Line 2</b>					
<b>Quasi-Peak</b>					
0.181	9.662	32.640	42.302	-22.812	65.114
0.212	9.661	28.890	38.551	-25.678	64.229
0.244	9.663	25.180	34.843	-28.471	63.314
0.545	9.679	28.910	38.589	-17.411	56.000
2.365	9.784	20.810	30.594	-25.406	56.000
19.240	10.185	11.360	21.545	-38.455	60.000
<b>Average</b>					
0.181	9.662	24.960	34.622	-20.492	55.114
0.212	9.661	20.580	30.241	-23.988	54.229
0.244	9.663	17.960	27.623	-25.691	53.314
0.545	9.679	27.290	36.969	-9.031	46.000
2.365	9.784	15.040	24.824	-21.176	46.000
19.240	10.185	5.340	15.525	-34.475	50.000

Note:

1. All Reading Levels are Quasi-Peak and average value.
2. “ “ means the worst emission level.
3. Measurement Level = Reading Level + Correct Factor

Product : Intel® Dual Band Wireless-AC 8260  
 Test Item : Conducted Emission Test  
 Power Line : Line 1  
 Test Mode : Mode 3 MIMO: Transmit - 802.11n-40BW\_30Mbps(2.4G Band) (2437MHz)

Frequency MHz	Correct Factor dB	Reading Level dBuV	Measurement Level dBuV	Margin dB	Limit dBuV
<b>Line 1</b>					
<b>Quasi-Peak</b>					
0.181	9.662	34.050	43.712	-21.402	65.114
0.209	9.661	28.080	37.741	-26.573	64.314
0.545	9.679	31.060	40.739	-15.261	56.000
0.576	9.681	30.760	40.441	-15.559	56.000
2.287	9.782	20.220	30.002	-25.998	56.000
19.306	10.055	13.040	23.095	-36.905	60.000
<b>Average</b>					
0.181	9.662	26.180	35.842	-19.272	55.114
0.209	9.661	20.360	30.021	-24.293	54.314
0.545	9.679	31.050	40.729	-5.271	46.000
0.576	9.681	29.900	39.581	-6.419	46.000
2.287	9.782	11.010	20.792	-25.208	46.000
19.306	10.055	7.480	17.535	-32.465	50.000

Note:

1. All Reading Levels are Quasi-Peak and average value.
2. "■" means the worst emission level.
3. Measurement Level = Reading Level + Correct Factor

Product : Intel® Dual Band Wireless-AC 8260  
 Test Item : Conducted Emission Test  
 Power Line : Line 2  
 Test Mode : Mode 3 MIMO: Transmit - 802.11n-40BW\_30Mbps(2.4G Band) (2437MHz)

Frequency MHz	Correct Factor dB	Reading Level dBuV	Measurement Level dBuV	Margin dB	Limit dBuV
<b>Line 2</b>					
<b>Quasi-Peak</b>					
0.154	9.670	35.520	45.190	-20.696	65.886
0.185	9.661	30.360	40.021	-24.979	65.000
0.216	9.661	25.130	34.791	-29.323	64.114
0.548	9.679	30.190	39.869	-16.131	56.000
2.341	9.783	21.500	31.283	-24.717	56.000
18.974	10.182	12.060	22.242	-37.758	60.000
<b>Average</b>					
0.154	9.670	24.580	34.250	-21.636	55.886
0.185	9.661	14.080	23.741	-31.259	55.000
0.216	9.661	9.370	19.031	-35.083	54.114
0.548	9.679	29.640	39.319	-6.681	46.000
2.341	9.783	11.170	20.953	-25.047	46.000
18.974	10.182	3.060	13.242	-36.758	50.000

Note:

1. All Reading Levels are Quasi-Peak and average value.
2. "■" means the worst emission level.
3. Measurement Level = Reading Level + Correct Factor

Product : Intel® Dual Band Wireless-AC 8260  
 Test Item : Conducted Emission Test  
 Power Line : Line 1  
 Test Mode : Mode 3 MIMO: Transmit - 802.11ac-80BW\_65Mbps(5G Band) (5775MHz)

Frequency MHz	Correct Factor dB	Reading Level dBuV	Measurement Level dBuV	Margin dB	Limit dBuV
<b>Line 1</b>					
<b>Quasi-Peak</b>					
0.150	9.671	37.200	46.871	-19.129	66.000
0.177	9.663	31.310	40.973	-24.256	65.229
0.209	9.661	29.790	39.451	-24.863	64.314
0.568	9.680	29.690	39.370	-16.630	56.000
2.345	9.783	20.130	29.913	-26.087	56.000
18.904	10.052	12.050	22.102	-37.898	60.000
<b>Average</b>					
0.150	9.671	30.480	40.151	-15.849	56.000
0.177	9.663	22.920	32.583	-22.646	55.229
0.209	9.661	22.410	32.071	-22.243	54.314
0.568	9.680	20.990	30.670	-15.330	46.000
2.345	9.783	10.320	20.103	-25.897	46.000
18.904	10.052	5.580	15.632	-34.368	50.000

Note:

1. All Reading Levels are Quasi-Peak and average value.
2. “ “ means the worst emission level.
3. Measurement Level = Reading Level + Correct Factor

Product : Intel® Dual Band Wireless-AC 8260  
 Test Item : Conducted Emission Test  
 Power Line : Line 2  
 Test Mode : Mode 3 MIMO: Transmit - 802.11ac-80BW\_65Mbps(5G Band) (5775MHz)

Frequency MHz	Correct Factor dB	Reading Level dBuV	Measurement Level dBuV	Margin dB	Limit dBuV
<b>Line 2</b>					
<b>Quasi-Peak</b>					
0.150	9.671	36.650	46.321	-19.679	66.000
0.181	9.662	32.960	42.622	-22.492	65.114
0.541	9.679	28.470	38.149	-17.851	56.000
0.568	9.680	28.610	38.290	-17.710	56.000
2.361	9.783	21.160	30.943	-25.057	56.000
19.377	10.186	11.950	22.136	-37.864	60.000
<b>Average</b>					
0.150	9.671	28.540	38.211	-17.789	56.000
0.181	9.662	16.730	26.392	-28.722	55.114
0.541	9.679	24.960	34.639	-11.361	46.000
0.568	9.680	23.240	32.920	-13.080	46.000
2.361	9.783	11.660	21.443	-24.557	46.000
19.377	10.186	2.690	12.876	-37.124	50.000

Note:

1. All Reading Levels are Quasi-Peak and average value.
2. “ ” means the worst emission level.
3. Measurement Level = Reading Level + Correct Factor

Product : Intel® Dual Band Wireless-AC 8260  
Test Item : Conducted Emission Test  
Power Line : Line 1  
Test Mode : Mode 4 Beamforming: Transmit - 802.11n-40BW\_30Mbps(2.4G Band) (2437MHz)

Frequency MHz	Correct Factor dB	Reading Level dBuV	Measurement Level dBuV	Margin dB	Limit dBuV
<b>Line 1</b>					
<b>Quasi-Peak</b>					
0.158	9.668	24.760	34.428	-31.343	65.771
0.185	9.661	30.260	39.921	-25.079	65.000
0.361	9.669	18.950	28.619	-31.352	59.971
0.568	9.680	30.540	40.220	-15.780	56.000
2.009	9.769	20.070	29.839	-26.161	56.000
19.349	10.056	11.960	22.016	-37.984	60.000
<b>Average</b>					
0.158	9.668	14.530	24.198	-31.573	55.771
0.185	9.661	18.250	27.911	-27.089	55.000
0.361	9.669	14.570	24.239	-25.732	49.971
0.568	9.680	26.890	36.570	-9.430	46.000
2.009	9.769	13.420	23.189	-22.811	46.000
19.349	10.056	1.070	11.126	-38.874	50.000

Note:

1. All Reading Levels are Quasi-Peak and average value.
2. "■" means the worst emission level.
3. Measurement Level = Reading Level + Correct Factor



Product : Intel® Dual Band Wireless-AC 8260  
 Test Item : Conducted Emission Test  
 Power Line : Line 2  
 Test Mode : Mode 4 Beamforming: Transmit - 802.11n-40BW\_30Mbps(2.4G Band) (2437MHz)

Frequency MHz	Correct Factor dB	Reading Level dBuV	Measurement Level dBuV	Margin dB	Limit dBuV
<b>Line 2</b>					
<b>Quasi-Peak</b>					
0.150	9.671	37.260	46.931	-19.069	66.000
0.173	9.664	21.600	31.264	-34.079	65.343
0.205	9.661	21.850	31.511	-32.918	64.429
0.568	9.680	28.960	38.640	-17.360	56.000
2.392	9.784	20.730	30.514	-25.486	56.000
19.650	10.199	10.460	20.659	-39.341	60.000
<b>Average</b>					
0.150	9.671	24.380	34.051	-21.949	56.000
0.173	9.664	15.480	25.144	-30.199	55.343
0.205	9.661	13.320	22.981	-31.448	54.429
0.568	9.680	26.050	35.730	-10.270	46.000
2.392	9.784	11.130	20.914	-25.086	46.000
19.650	10.199	3.850	14.049	-35.951	50.000

Note:

1. All Reading Levels are Quasi-Peak and average value.
2. "■" means the worst emission level.
3. Measurement Level = Reading Level + Correct Factor

Product : Intel® Dual Band Wireless-AC 8260  
 Test Item : Conducted Emission Test  
 Power Line : Line 1  
 Test Mode : Mode 4 Beamforming: Transmit - 802.11ac-80BW\_65Mbps(5G Band) (5775MHz)

Frequency MHz	Correct Factor dB	Reading Level dBuV	Measurement Level dBuV	Margin dB	Limit dBuV
<b>Line 1</b>					
<b>Quasi-Peak</b>					
0.185	9.661	30.760	40.421	-24.579	65.000
0.216	9.661	25.190	34.851	-29.263	64.114
0.548	9.679	29.650	39.329	-16.671	56.000
0.572	9.681	31.270	40.951	-15.049	56.000
2.408	9.785	20.030	29.815	-26.185	56.000
19.291	10.055	12.210	22.265	-37.735	60.000
<b>Average</b>					
0.185	9.661	17.750	27.411	-27.589	55.000
0.216	9.661	17.140	26.801	-27.313	54.114
0.548	9.679	27.680	37.359	-8.641	46.000
0.572	9.681	27.920	37.601	-8.399	46.000
2.408	9.785	12.710	22.495	-23.505	46.000
19.291	10.055	1.770	11.825	-38.175	50.000

Note:

1. All Reading Levels are Quasi-Peak and average value.
2. “ “ means the worst emission level.
3. Measurement Level = Reading Level + Correct Factor

Product : Intel® Dual Band Wireless-AC 8260  
 Test Item : Conducted Emission Test  
 Power Line : Line 2  
 Test Mode : Mode 4 Beamforming: Transmit - 802.11ac-80BW\_65Mbps(5G Band) (5775MHz)

Frequency MHz	Correct Factor dB	Reading Level dBuV	Measurement Level dBuV	Margin dB	Limit dBuV
<b>Line 2</b>					
<b>Quasi-Peak</b>					
0.177	9.663	31.230	40.893	-24.336	65.229
0.185	9.661	29.540	39.201	-25.799	65.000
0.209	9.661	28.730	38.391	-25.923	64.314
0.545	9.679	29.360	39.039	-16.961	56.000
2.302	9.782	20.150	29.932	-26.068	56.000
18.388	10.167	9.310	19.477	-40.523	60.000
<b>Average</b>					
0.177	9.663	24.550	34.213	-21.016	55.229
0.185	9.661	19.240	28.901	-26.099	55.000
0.209	9.661	20.360	30.021	-24.293	54.314
0.545	9.679	28.410	38.089	-7.911	46.000
2.302	9.782	14.470	24.252	-21.748	46.000
18.388	10.167	3.050	13.217	-36.783	50.000

Note:

1. All Reading Levels are Quasi-Peak and average value.
2. “ “ means the worst emission level.
3. Measurement Level = Reading Level + Correct Factor

### 3. Peak Power Output

#### 3.1. Test Equipment

	Equipment	Manufacturer	Model No./Serial No.	Last Cal.
X	Power Meter	Anritsu	ML2495A/6K00003357	May, 2014
X	Power Sensor	Anritsu	MA2411B/0738448	Jun., 2014
	Spectrum Analyzer	R&S	FSP40 / 100170	Jun., 2014
	Spectrum Analyzer	Agilent	E4407B / US39440758	Jun., 2014
X	Spectrum Analyzer	Agilent	N9010A / MY48030495	Apr., 2014

Note:

1. All equipments are calibrated with traceable calibrations. Each calibration is traceable to the national or international standards.
2. The test instruments marked with “X” are used to measure the final test results.

#### 3.2. Test Setup

##### Conduction Power Measurement (for $\leq 40$ MHz)

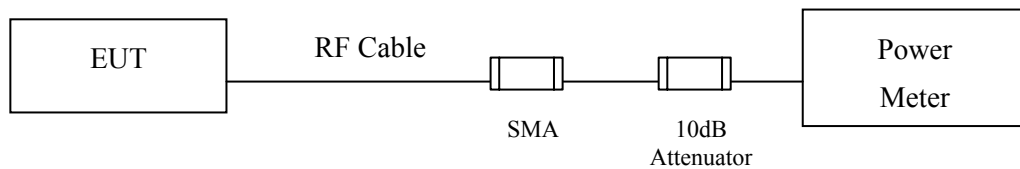

##### Conduction Power Measurement (for 80 MHz)

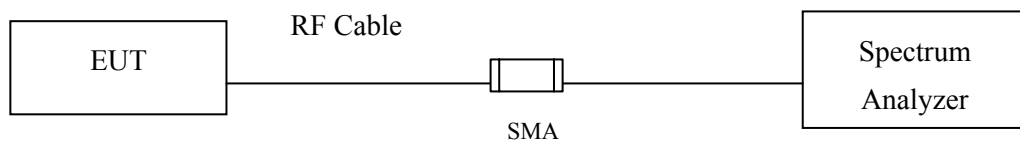

#### 3.3. Limits

The maximum peak power shall be less 1 Watt.

### 3.4. Test Procedure

The EUT was tested according to DTS test procedure of KDB 558074 for compliance to FCC 47CFR 15.247 requirements.

**BW ≤ 40MHz:** The maximum peak conducted output power using KDB 558074 D01 DTS Meas Guidance v03r02 section 9.1.2 PKPM1 Peak power meter method

Note: the power meter have a video bandwidth that is greater than or equal to the measurement bandwidth, (Anritsu/ MA2411B video bandwidth: 50MHz)

**BW=80MHz:** The maximum average conducted output power using KDB 558074 D01 DTS Meas Guidance v03r02 section 9.2.2.2 Method AVGSA-1, Measurement using a spectrum analyzer (SA) for 802.11ac. (Trace averaging with the EUT transmitting at full power throughout each sweep).

### 3.5. Uncertainty

Power sensor/meter method: ± 0.517 dB

Spectrum analyzer method: ± 1.27 dB

### 3.6. Test Result of Peak Power Output

Product : Intel® Dual Band Wireless-AC 8260  
 Test Item : Peak Power Output Data  
 Test Site : No.3 OATS  
 Test Mode : Mode 1 SISO A: Transmit (802.11b 1Mbps)

Channel No	Frequency (MHz)	Average Power For different Data Rate (Mbps)				Peak Power	Required Limit	Result
		1	2	5.5	11			
		Measurement Level (dBm)						
01	2412	21.2	--	--	--	22.8	<30dBm	Pass
06	2437	21.02	20.97	20.92	20.87	22.58	<30dBm	Pass
11	2462	20.71	--	--	--	22.33	<30dBm	Pass
12	2467	15.18	--	--	--	17.56	<30dBm	Pass

Note: Peak Power Output Value = Reading value on power meter + cable loss

Product : Intel® Dual Band Wireless-AC 8260  
 Test Item : Peak Power Output Data  
 Test Site : No.3 OATS  
 Test Mode : Mode 1 SISO A: Transmit (802.11g 6Mbps)

Channel No	Frequency (MHz)	Average Power For different Data Rate (Mbps)								Peak Power	Required Limit	Result
		6	9	12	18	24	36	48	54			
		Measurement Level (dBm)										
01	2412	19.76	--	--	--	--	--	--	--	23.58	<30dBm	Pass
06	2437	20.98	20.92	20.86	20.8	20.74	20.68	20.62	20.56	23.9	<30dBm	Pass
10	2457	19.47	--	--	--	--	--	--	--	23.39	<30dBm	Pass
11	2462	18.19	--	--	--	--	--	--	--	22.78	<30dBm	Pass
12	2467	12.55	--	--	--	--	--	--	--	17.63	<30dBm	Pass

Note: Peak Power Output Value = Reading value on power meter + cable loss

Product : Intel® Dual Band Wireless-AC 8260  
 Test Item : Peak Power Output Data  
 Test Site : No.3 OATS  
 Test Mode : Mode 1 SISO A: Transmit - 802.11a 6Mbps

Channel No	Frequency (MHz)	Average Power For different Data Rate (Mbps)								Peak Power	Required Limit	Result
		6	9	12	18	24	36	48	54			
		Measurement Level (dBm)										
149	5745	20.88	--	--	--	--	--	--	--	23.53	<30dBm	Pass
157	5785	20.55	20.43	20.37	20.28	20.11	19.93	19.84	19.76	23.46	<30dBm	Pass
165	5825	20.49	--	--	--	--	--	--	--	23.33	<30dBm	Pass

Note: Peak Power Output Value = Reading value on power meter + cable loss



Product : Intel® Dual Band Wireless-AC 8260  
 Test Item : Peak Power Output Data  
 Test Site : No.3 OATS  
 Test Mode : Mode 1 SISO A: Transmit - 802.11n-20BW\_7.2Mbps(2.4G Band)

Channel No	Frequency (MHz)	Average Power For different Data Rate (Mbps)								Peak Power	Required Limit	Result
		HT0	HT1	HT2	HT3	HT4	HT5	HT6	HT7	HT0		
		Measurement Level (dBm)										
01	2412	18.93	--	--	--	--	--	--	--	23.3	<30dBm	Pass
06	2437	21.13	21.07	21.01	20.95	20.89	20.83	20.77	20.71	23.95	<30dBm	Pass
10	2457	18.66	--	--	--	--	--	--	--	23.12	<30dBm	Pass
11	2462	17.08	--	--	--	--	--	--	--	22.15	<30dBm	Pass
12	2467	12.2	--	--	--	--	--	--	--	17.51	<30dBm	Pass

Note: Peak Power Output Value = Reading value on power meter + cable loss

Product : Intel® Dual Band Wireless-AC 8260  
 Test Item : Peak Power Output Data  
 Test Site : No.3 OATS  
 Test Mode : Mode 1 SISO A: Transmit - 802.11n-40BW\_15Mbps(2.4G Band)

Channel No	Frequency (MHz)	Average Power For different Data Rate (Mbps)								Peak Power	Required Limit	Result
		HT0	HT1	HT2	HT3	HT4	HT5	HT6	HT7	HT0		
		Measurement Level (dBm)										
03	2422	16.69	--	--	--	--	--	--	--	20.19	<30dBm	Pass
04	2427	17.34	--	--	--	--	--	--	--	20.94	<30dBm	Pass
06	2437	18.32	18.27	18.22	18.17	18.12	18.07	18.02	17.97	21.61	<30dBm	Pass
08	2447	17.26	--	--	--	--	--	--	--	20.69	<30dBm	Pass
09	2452	14.58	--	--	--	--	--	--	--	18.16	<30dBm	Pass
10	2457	11.23	--	--	--	--	--	--	--	14.97	<30dBm	Pass

Note: Peak Power Output Value = Reading value on power meter + cable loss

Product : Intel® Dual Band Wireless-AC 8260  
 Test Item : Peak Power Output Data  
 Test Site : No.3 OATS  
 Test Mode : Mode 1 SISO A: Transmit - 802.11n-20BW\_7.2Mbps(5G Band)

Channel No	Frequency (MHz)	Average Power For different Data Rate (Mbps)									Peak Power	Required Limit	Result
		HT0	HT1	HT2	HT3	HT4	HT5	HT6	HT7	HT0			
		Measurement Level (dBm)											
149	5745	20.88	--	--	--	--	--	--	--	22.74	<30dBm	Pass	
157	5785	20.71	20.66	20.58	20.47	20.31	20.24	20.16	20.04	22.61	<30dBm	Pass	
165	5825	20.68	--	--	--	--	--	--	--	22.59	<30dBm	Pass	

1. Note: Peak Power Output Value = Reading value on power meter + cable loss

Product : Intel® Dual Band Wireless-AC 8260  
 Test Item : Peak Power Output Data  
 Test Site : No.3 OATS  
 Test Mode : Mode 1 SISO A: Transmit - 802.11n-40BW\_15Mbps(5G Band)

Channel No	Frequency (MHz)	Average Power									Peak Power	Required Limit	Result
		For different Data Rate (Mbps)											
		HT0	HT1	HT2	HT3	HT4	HT5	HT6	HT7	HT0			
Measurement Level (dBm)													
151	5755	20.91	20.84	20.71	20.65	20.53	20.42	20.38	20.29	23.21	<30dBm	Pass	
159	5795	20.88	--	--	--	--	--	--	--	23.16	<30dBm	Pass	

Note: Peak Power Output Value = Reading value on power meter + cable loss

Product : Intel® Dual Band Wireless-AC 8260  
 Test Item : Peak Power Output Data  
 Test Site : No.3 OATS  
 Test Mode : Mode 1 SISO A: Transmit - 802.11ac-80BW\_32.5Mbps(5G Band)

Channel No	Frequency (MHz)	Average Power For different Data Rate (Mbps)										Required Limit	Result
		VTH0	VTH1	VTH2	VTH3	VTH4	VTH5	VTH6	VTH7	VTH8	VTH9		
		Measurement Level (dBm)											
155	5775	20.89	20.53	20.47	20.36	20.27	20.15	20.04	19.93	20.61	20.61	<30dBm	Pass

Note: Peak Power Output Value = Reading value on power meter + cable loss

**Figure Channel 155:**

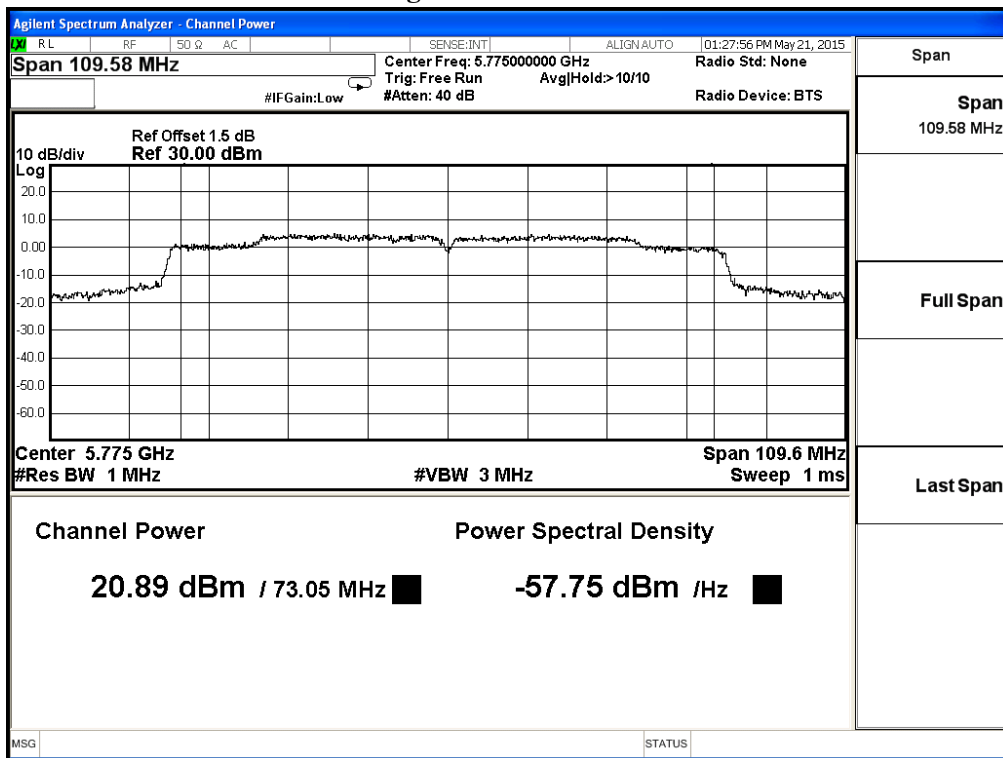

Product : Intel® Dual Band Wireless-AC 8260  
 Test Item : Peak Power Output Data  
 Test Site : No.3 OATS  
 Test Mode : Mode 2 SISO B: Transmit (802.11b 1Mbps)

Channel No	Frequency (MHz)	Average Power For different Data Rate (Mbps)				Peak Power	Required Limit	Result
		1	2	5.5	11			
		Measurement Level (dBm)						
01	2412	21.08	--	--	--	22.71	<30dBm	Pass
06	2437	20.83	20.79	20.75	20.71	22.46	<30dBm	Pass
10	2457	20.77	--	--	--	22.43	<30dBm	Pass
11	2462	18.02	--	--	--	19.81	<30dBm	Pass
12	2467	13.69	--	--	--	15.43	<30dBm	Pass

Note: Peak Power Output Value = Reading value on power meter + cable loss

Product : Intel® Dual Band Wireless-AC 8260  
 Test Item : Peak Power Output Data  
 Test Site : No.3 OATS  
 Test Mode : Mode 2 SISO B: Transmit (802.11g 6Mbps)

Channel No	Frequency (MHz)	Average Power For different Data Rate (Mbps)								Peak Power	Required Limit	Result
		6	9	12	18	24	36	48	54			
		Measurement Level (dBm)										
01	2412	18.27	--	--	--	--	--	--	--	22.92	<30dBm	Pass
06	2437	21.07	21.01	20.95	20.89	20.83	20.77	20.71	20.65	23.79	<30dBm	Pass
10	2457	18.45	--	--	--	--	--	--	--	22.83	<30dBm	Pass
11	2462	17.05	--	--	--	--	--	--	--	21.94	<30dBm	Pass
12	2467	11.47	--	--	--	--	--	--	--	16.84	<30dBm	Pass

Note: Peak Power Output Value = Reading value on power meter + cable loss

Product : Intel® Dual Band Wireless-AC 8260  
 Test Item : Peak Power Output Data  
 Test Site : No.3 OATS  
 Test Mode : Mode 2 SISO B: Transmit - 802.11a 6Mbps

Channel No	Frequency (MHz)	Average Power For different Data Rate (Mbps)								Peak Power	Required Limit	Result
		6	9	12	18	24	36	48	54			
		Measurement Level (dBm)										
149	5745	20.56	--	--	--	--	--	--	--	23.64	<30dBm	Pass
157	5785	20.53	20.46	20.37	20.28	20.14	20.06	19.93	19.84	23.58	<30dBm	Pass
165	5825	20.83	--	--	--	--	--	--	--	23.41	<30dBm	Pass

Note: Peak Power Output Value = Reading value on power meter + cable loss



Product : Intel® Dual Band Wireless-AC 8260  
 Test Item : Peak Power Output Data  
 Test Site : No.3 OATS  
 Test Mode : Mode 2 SISO B: Transmit - 802.11n-20BW\_7.2Mbps(2.4G Band)

Channel No	Frequency (MHz)	Average Power For different Data Rate (Mbps)								Peak Power	Required Limit	Result
		HT0	HT1	HT2	HT3	HT4	HT5	HT6	HT7	HT0		
		Measurement Level (dBm)										
01	2412	17.9	--	--	--	--	--	--	--	22.71	<30dBm	Pass
02	2417	19.96	--	--	--	--	--	--	--	23.72	<30dBm	Pass
06	2437	20.98	20.92	20.86	20.8	20.74	20.68	20.62	20.56	23.88	<30dBm	Pass
09	2452	18.75	--	--	--	--	--	--	--	23.12	<30dBm	Pass
10	2457	17.86	--	--	--	--	--	--	--	22.65	<30dBm	Pass
11	2462	15.91	--	--	--	--	--	--	--	20.91	<30dBm	Pass
12	2467	11.08	--	--	--	--	--	--	--	16.77	<30dBm	Pass

Note: Peak Power Output Value =Reading value on power meter + cable loss

Product : Intel® Dual Band Wireless-AC 8260  
 Test Item : Peak Power Output Data  
 Test Site : No.3 OATS  
 Test Mode : Mode 2 SISO B: Transmit - 802.11n-40BW\_15Mbps(2.4G Band)

Channel No	Frequency (MHz)	Average Power For different Data Rate (Mbps)								Peak Power	Required Limit	Result
		HT0	HT1	HT2	HT3	HT4	HT5	HT6	HT7	HT0		
		Measurement Level (dBm)										
03	2422	14.72	--	--	--	--	--	--	--	18.32	<30dBm	Pass
04	2427	16.65	--	--	--	--	--	--	--	20.22	<30dBm	Pass
06	2437	17.38	17.31	17.24	17.17	17.1	17.03	16.96	16.89	20.83	<30dBm	Pass
08	2447	16.52	--	--	--	--	--	--	--	20.03	<30dBm	Pass
09	2452	14.02	--	--	--	--	--	--	--	14.67	<30dBm	Pass
10	2457	7.87	--	--	--	--	--	--	--	11.73	<30dBm	Pass

Note: Peak Power Output Value = Reading value on power meter + cable loss

Product : Intel® Dual Band Wireless-AC 8260  
 Test Item : Peak Power Output Data  
 Test Site : No.3 OATS  
 Test Mode : Mode 2 SISO B: Transmit - 802.11n-20BW\_7.2Mbps(5G Band)

Channel No	Frequency (MHz)	Average Power For different Data Rate (Mbps)									Peak Power	Required Limit	Result
		HT0	HT1	HT2	HT3	HT4	HT5	HT6	HT7	HT0			
		Measurement Level (dBm)											
149	5745	20.48	--	--	--	--	--	--	--	23.32	<30dBm	Pass	
157	5785	20.46	20.35	20.28	20.17	20.08	19.97	19.83	19.74	23.51	<30dBm	Pass	
165	5825	20.48	--	--	--	--	--	--	--	23.36	<30dBm	Pass	

Note: Peak Power Output Value = Reading value on power meter + cable loss

Product : Intel® Dual Band Wireless-AC 8260  
 Test Item : Peak Power Output Data  
 Test Site : No.3 OATS  
 Test Mode : Mode 2 SISO B: Transmit - 802.11n-40BW\_15Mbps(5G Band)

Channel No	Frequency (MHz)	Average Power									Peak Power	Required Limit	Result
		For different Data Rate (Mbps)											
		HT0	HT1	HT2	HT3	HT4	HT5	HT6	HT7	HT0			
Measurement Level (dBm)													
151	5755	20.72	20.64	20.53	20.47	20.31	20.28	20.11	20.06	23.47	<30dBm	Pass	
159	5795	20.66	--	--	--	--	--	--	--	23.46	<30dBm	Pass	

Note: Peak Power Output Value = Reading value on power meter + cable loss

Product : Intel® Dual Band Wireless-AC 8260  
 Test Item : Peak Power Output Data  
 Test Site : No.3 OATS  
 Test Mode : Mode 2 SISO B: Transmit - 802.11ac-80BW\_32.5Mbps(5G Band)

Channel No	Frequency (MHz)	Average Power For different Data Rate (Mbps)										Required Limit	Result
		VTH0	VTH1	VTH2	VTH3	VTH4	VTH5	VTH6	VTH7	VTH8	VTH9		
		Measurement Level (dBm)											
155	5775	20.76	20.58	20.46	20.37	20.21	20.18	20.06	19.97	20.63	20.63	<30dBm	Pass

Note: Peak Power Output Value = Reading value on power meter + cable loss

**Figure Channel 155:**

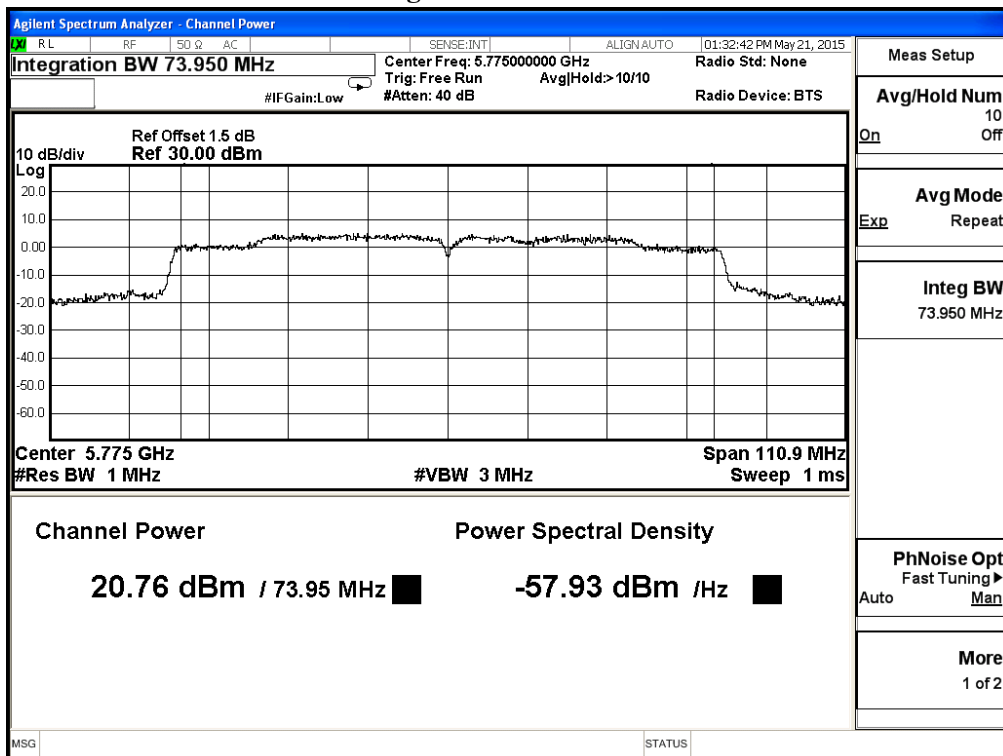

Product : Intel® Dual Band Wireless-AC 8260  
 Test Item : Peak Power Output Data  
 Test Site : No.3 OATS  
 Test Mode : Mode 3 MIMO: Transmit - 802.11n-20BW\_14.4Mbps(2.4G Band)

Chain A

Channel No	Frequency (MHz)	Average Power For different Data Rate (Mbps)								Peak Power	Required Limit	Result
		HT8	HT9	HT10	HT11	HT12	HT13	HT14	HT15	HT8		
		Measurement Level (dBm)										
01	2412	17.34	--	--	--	--	--	--	--	22.16	<30dBm	Pass
06	2437	18.02	17.97	17.92	17.87	17.82	17.77	17.72	17.67	22.42	<30dBm	Pass
10	2457	17.97	--	--	--	--	--	--	--	22.5	<30dBm	Pass
11	2462	16.3	--	--	--	--	--	--	--	21.17	<30dBm	Pass
12	2467	12.33	--	--	--	--	--	--	--	17.52	<30dBm	Pass

Note: Peak Power Output Value =Reading value on power meter + cable loss

Chain B

Channel No	Frequency (MHz)	Average Power For different Data Rate (Mbps)								Peak Power	Required Limit	Result
		HT8	HT9	HT10	HT11	HT12	HT13	HT14	HT15	HT8		
		Measurement Level (dBm)										
01	2412	17.11	--	--	--	--	--	--	--	22.02	<30dBm	Pass
06	2437	18.03	17.97	17.91	17.85	17.79	17.73	17.67	17.61	22.43	<30dBm	Pass
10	2457	17.97	--	--	--	--	--	--	--	22.5	<30dBm	Pass
11	2462	16.28	--	--	--	--	--	--	--	21.12	<30dBm	Pass
12	2467	12.2	--	--	--	--	--	--	--	17.46	<30dBm	Pass

Note: Peak Power Output Value =Reading value on power meter + cable loss

**CHAIN A+B**

Channel	Frequency (MHz)	Data Rata (Mbps)	Chain A Power (dBm)	Chain B Power (dBm)	Chain A+B Power (dBm)	Limit (dBm)	Result
1	2412	HT8	22.16	22.02	25.10	<30dBm	Pass
6	2437	HT8	22.42	22.43	25.44	<30dBm	Pass
10	2457	HT8	22.50	22.50	25.51	<30dBm	Pass
11	2462	HT8	21.17	21.12	24.16	<30dBm	Pass
12	2467	HT8	17.52	17.46	20.50	<30dBm	Pass

Note: Peak Power Output Value (dBm) = 10\*LOG (Chain A (mW)+ Chain B (mW))

Product : Intel® Dual Band Wireless-AC 8260  
 Test Item : Peak Power Output Data  
 Test Site : No.3 OATS  
 Test Mode : Mode 3 MIMO: Transmit - 802.11n-40BW\_30Mbps(2.4G Band)

Chain A

Channel No	Frequency (MHz)	Average Power For different Data Rate (Mbps)								Peak Power	Required Limit	Result
		HT8	HT9	HT10	HT11	HT12	HT13	HT14	HT15	HT8		
		Measurement Level (dBm)										
03	2422	14.85	--	--	--	--	--	--	--	18.62	<30dBm	Pass
04	2427	15.48	--	--	--	--	--	--	--	19.95	<30dBm	Pass
06	2437	17.23	17.18	17.13	17.08	17.03	16.98	16.93	16.88	20.85	<30dBm	Pass
09	2452	16.01	--	--	--	--	--	--	--	20.71	<30dBm	Pass
10	2457	11.12	--	--	--	--	--	--	--	15.19	<30dBm	Pass

Note: Peak Power Output Value =Reading value on power meter + cable loss

Chain B

Channel No	Frequency (MHz)	Average Power For different Data Rate (Mbps)								Peak Power	Required Limit	Result
		HT8	HT9	HT10	HT11	HT12	HT13	HT14	HT15	HT8		
		Measurement Level (dBm)										
03	2422	14.56	--	--	--	--	--	--	--	18.32	<30dBm	Pass
04	2427	15.49	--	--	--	--	--	--	--	19.94	<30dBm	Pass
06	2437	17.26	17.22	17.18	17.14	17.1	17.06	17.02	16.98	20.82	<30dBm	Pass
09	2452	15.84	--	--	--	--	--	--	--	20.65	<30dBm	Pass
10	2457	10.96	--	--	--	--	--	--	--	15.11	<30dBm	Pass

Note: Peak Power Output Value =Reading value on power meter + cable loss



**CHAIN A+B**

Channel	Frequency (MHz)	Data Rate (Mbps)	Chain A Power (dBm)	Chain B Power (dBm)	Chain A+B Power (dBm)	Limit (dBm)	Result
3	2422	HT8	18.62	18.32	21.48	<30dBm	Pass
4	2427	HT8	19.95	19.94	22.96	<30dBm	Pass
6	2437	HT8	20.85	20.82	23.85	<30dBm	Pass
9	2452	HT8	20.71	20.65	23.69	<30dBm	Pass
10	2457	HT8	15.19	15.11	18.16	<30dBm	Pass

Note: Peak Power Output Value (dBm) = 10\*LOG (Chain A (mW)+ Chain B (mW))

Product : Intel® Dual Band Wireless-AC 8260  
 Test Item : Peak Power Output Data  
 Test Site : No.3 OATS  
 Test Mode : Mode 3 MIMO: Transmit - 802.11n-20BW\_14.4Mbps(5G Band)

**Chain A**

Channel No	Frequency (MHz)	Average Power For different Data Rate (Mbps)									Peak Power	Required Limit	Result
		HT8	HT9	HT10	HT11	HT12	HT13	HT14	HT15	HT8			
		Measurement Level (dBm)											
149	5745	18.13	--	--	--	--	--	--	--	22.71	<30dBm	Pass	
157	5785	18.06	17.94	17.84	17.73	17.65	17.58	17.43	17.37	22.92	<30dBm	Pass	
165	5825	18.03	--	--	--	--	--	--	--	22.53	<30dBm	Pass	

Note: Peak Power Output Value =Reading value on power meter + cable loss

**Chain B**

Channel No	Frequency (MHz)	Average Power For different Data Rate (Mbps)									Peak Power	Required Limit	Result
		HT8	HT9	HT10	HT11	HT12	HT13	HT14	HT15	HT8			
		Measurement Level (dBm)											
149	5745	18.1	--	--	--	--	--	--	--	22.66	<30dBm	Pass	
157	5785	17.97	17.85	17.74	17.68	17.52	17.49	17.33	17.28	22.89	<30dBm	Pass	
165	5825	17.96	--	--	--	--	--	--	--	22.41	<30dBm	Pass	

Note: Peak Power Output Value =Reading value on power meter + cable loss

**CHAIN A+B**

Channel	Frequency (MHz)	Data Rata (Mbps)	Chain A Power (dBm)	Chain B Power (dBm)	Chain A+B Power (dBm)	Limit (dBm)	Result
149	5745	HT8	22.71	22.66	25.70	<30dBm	Pass
157	5785	HT8	22.92	22.89	25.92	<30dBm	Pass
165	5825	HT8	22.53	22.41	25.48	<30dBm	Pass

Note: Peak Power Output Value (dBm) = 10\*LOG (Chain A (mW)+ Chain B (mW))

Product : Intel® Dual Band Wireless-AC 8260  
 Test Item : Peak Power Output Data  
 Test Site : No.3 OATS  
 Test Mode : Mode 3 MIMO: Transmit - 802.11n-40BW\_30Mbps(5G Band)

**Chain A**

Channel No	Frequency (MHz)	Average Power For different Data Rate (Mbps)									Peak Power	Required Limit	Result
		HT8	HT9	HT10	HT11	HT12	HT13	HT14	HT15	HT8			
		Measurement Level (dBm)											
151	5755	18.12	--	--	--	--	--	--	--	22.69	<30dBm	Pass	
159	5795	18.28	18.17	18.05	17.94	17.84	17.76	17.66	17.52	22.72	<30dBm	Pass	

Note: Peak Power Output Value =Reading value on power meter + cable loss

**Chain B**

Channel No	Frequency (MHz)	Average Power For different Data Rate (Mbps)									Peak Power	Required Limit	Result
		HT8	HT9	HT10	HT11	HT12	HT13	HT14	HT15	HT8			
		Measurement Level (dBm)											
151	5755	18.07	--	--	--	--	--	--	--	22.73	<30dBm	Pass	
159	5795	18.03	17.97	17.84	17.76	17.61	17.58	17.43	17.37	22.66	<30dBm	Pass	

Note: Peak Power Output Value =Reading value on power meter + cable loss

**CHAIN A+B**

Channel	Frequency (MHz)	Data Rata (Mbps)	Chain A Power (dBm)	Chain B Power (dBm)	Chain A+B Power (dBm)	Limit (dBm)	Result
151	5755	HT8	22.69	22.73	25.72	<30dBm	Pass
159	5795	HT8	22.72	22.66	25.70	<30dBm	Pass

Note: Peak Power Output Value (dBm) = 10\*LOG (Chain A (mW)+ Chain B (mW))

Product : Intel® Dual Band Wireless-AC 8260  
 Test Item : Peak Power Output Data  
 Test Site : No.3 OATS  
 Test Mode : Mode 3 MIMO: Transmit - 802.11ac-80BW\_65Mbps(5G Band)

**Chain A**

Channel No	Frequency (MHz)	Average Power											Required Limit	Result
		For different Data Rate (Mbps)												
		VTH0	VTH1	VTH2	VTH3	VTH4	VTH5	VTH6	VTH7	VTH8	VTH9	VTH0		
Measurement Level (dBm)														
155	5775	20.76	20.64	20.53	20.48	20.31	20.26	20.11	20.05	19.94	19.83	20.74	<30dBm	Pass

Note: Peak Power Output Value =Reading value on power meter + cable loss

**Chain B**

Channel No	Frequency (MHz)	Average Power											Required Limit	Result
		For different Data Rate (Mbps)												
		VTH0	VTH1	VTH2	VTH3	VTH4	VTH5	VTH6	VTH7	VTH8	VTH9	VTH0		
Measurement Level (dBm)														
155	5775	20.60	20.53	20.47	20.36	20.28	20.17	20.06	19.97	19.83	19.77	20.73	<30dBm	Pass

Note: Peak Power Output Value =Reading value on power meter + cable loss

**(CHAIN A+ B)**

Channel Number	Frequency (MHz)	Data Rata (Mbps)	Chain A Power (dBm)	Chain B Power (dBm)	Output Power (dBm)	Output Power Limit
						(dBm)
155	5775	VTH0	20.76	20.60	23.69	30

Note:

1. Power Output Value =Reading value on average power meter + cable loss
2. Output Power (dBm) = 10LOG (Chain A Power (mW)+ Chain B Power (mW))

Figure Channel 155: (Chain A)

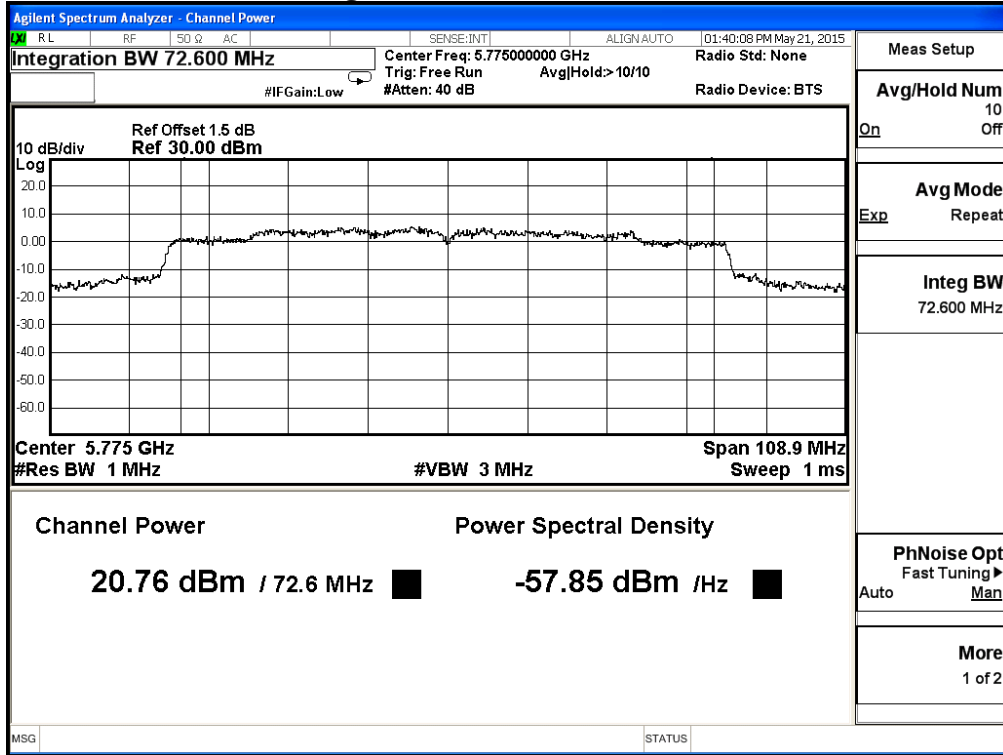
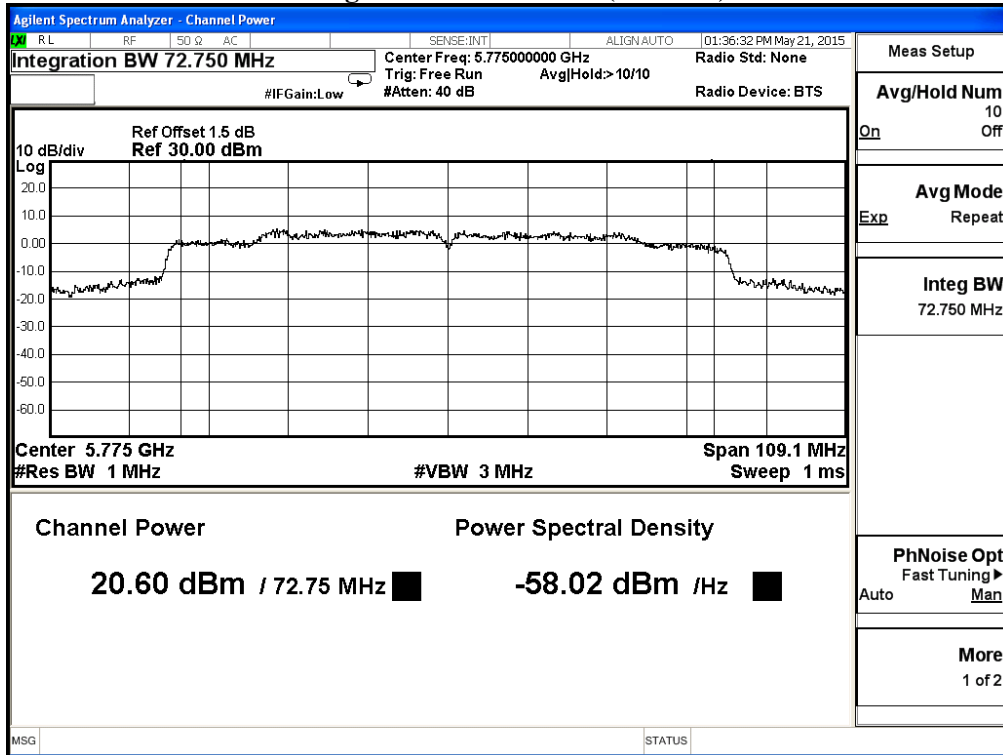

Figure Channel 155: (Chain B)



Product : Intel® Dual Band Wireless-AC 8260  
 Test Item : Peak Power Output Data  
 Test Site : No.3 OATS  
 Test Mode : Mode 4 Beamforming: Transmit - 802.11n-20BW\_14.4Mbps(2.4G Band)

Chain A

Channel No	Frequency (MHz)	Average Power For different Data Rate (Mbps)								Peak Power	Required Limit	Result
		HT8	HT9	HT10	HT11	HT12	HT13	HT14	HT15	HT8		
		Measurement Level (dBm)										
01	2412	17.12	--	--	--	--	--	--	--	22	<30dBm	Pass
06	2437	17.86	17.82	17.78	17.74	17.7	17.66	17.62	17.58	22.43	<30dBm	Pass
10	2457	18.02	--	--	--	--	--	--	--	22.57	<30dBm	Pass
11	2462	16.07	--	--	--	--	--	--	--	21.22	<30dBm	Pass
12	2467	10.63	--	--	--	--	--	--	--	16.18	<30dBm	Pass

Note: Peak Power Output Value =Reading value on power meter + cable loss

Chain B

Channel No	Frequency (MHz)	Average Power For different Data Rate (Mbps)								Peak Power	Required Limit	Result
		HT8	HT9	HT10	HT11	HT12	HT13	HT14	HT15	HT8		
		Measurement Level (dBm)										
01	2412	16.91	--	--	--	--	--	--	--	21.91	<30dBm	Pass
06	2437	17.92	17.86	17.8	17.74	17.68	17.62	17.56	17.5	22.67	<30dBm	Pass
10	2457	18.06	--	--	--	--	--	--	--	22.54	<30dBm	Pass
11	2462	16.11	--	--	--	--	--	--	--	21.17	<30dBm	Pass
12	2467	10.54	--	--	--	--	--	--	--	15.91	<30dBm	Pass

Note: Peak Power Output Value =Reading value on power meter + cable loss

**CHAIN A+B**

Channel	Frequency (MHz)	Data Rate (Mbps)	Chain A Power (dBm)	Chain B Power (dBm)	Chain A+B Power (dBm)	Limit (dBm)	Result
1	2412	HT8	22.00	21.91	24.97	<30dBm	Pass
6	2437	HT8	22.43	22.67	25.56	<30dBm	Pass
10	2457	HT8	22.57	22.54	25.57	<30dBm	Pass
11	2462	HT8	21.22	21.17	24.21	<30dBm	Pass
12	2467	HT8	16.18	15.91	19.06	<30dBm	Pass

Note: Peak Power Output Value (dBm) = 10\*LOG (Chain A (mW)+ Chain B (mW))

Product : Intel® Dual Band Wireless-AC 8260  
 Test Item : Peak Power Output Data  
 Test Site : No.3 OATS  
 Test Mode : Mode 4 Beamforming: Transmit - 802.11n-40BW\_30Mbps(2.4G Band)

Chain A

Channel No	Frequency (MHz)	Average Power For different Data Rate (Mbps)								Peak Power	Required Limit	Result
		HT8	HT9	HT10	HT11	HT12	HT13	HT14	HT15	HT8		
		Measurement Level (dBm)										
03	2422	11.62	--	--	--	--	--	--	--	15.3	<30dBm	Pass
04	2427	12.79	--	--	--	--	--	--	--	16.53	<30dBm	Pass
05	2432	13.85	--	--	--	--	--	--	--	17.56	<30dBm	Pass
06	2437	14.59	14.57	14.55	14.53	14.51	14.49	14.47	14.45	18.37	<30dBm	Pass
09	2452	15.62	--	--	--	--	--	--	--	19.35	<30dBm	Pass
10	2457	9.72	--	--	--	--	--	--	--	13.76	<30dBm	Pass

Note: Peak Power Output Value =Reading value on power meter + cable loss

Chain B

Channel No	Frequency (MHz)	Average Power For different Data Rate (Mbps)								Peak Power	Required Limit	Result
		HT8	HT9	HT10	HT11	HT12	HT13	HT14	HT15	HT8		
		Measurement Level (dBm)										
03	2422	11.42	--	--	--	--	--	--	--	15.06	<30dBm	Pass
04	2427	12.84	--	--	--	--	--	--	--	16.62	<30dBm	Pass
05	2432	13.88	--	--	--	--	--	--	--	17.57	<30dBm	Pass
06	2437	14.6	14.52	14.44	14.36	14.28	14.2	14.12	14.04	18.41	<30dBm	Pass
09	2452	15.48	--	--	--	--	--	--	--	19.14	<30dBm	Pass
10	2457	9.53	--	--	--	--	--	--	--	13.53	<30dBm	Pass

Note: Peak Power Output Value =Reading value on power meter + cable loss



**CHAIN A+B**

Channel	Frequency (MHz)	Data Rate (Mbps)	Chain A Power (dBm)	Chain B Power (dBm)	Chain A+B Power (dBm)	Limit (dBm)	Result
3	2422	HT8	15.30	15.06	18.19	<30dBm	Pass
4	2427	HT8	16.53	16.62	19.59	<30dBm	Pass
5	2432	HT8	17.56	17.57	20.58	<30dBm	Pass
6	2437	HT8	18.37	18.41	21.40	<30dBm	Pass
9	2452	HT8	19.35	19.14	22.26	<30dBm	Pass
10	2457	HT8	13.76	13.53	16.66	<30dBm	Pass

Note: Peak Power Output Value (dBm) = 10\*LOG (Chain A (mW)+ Chain B (mW))

Product : Intel® Dual Band Wireless-AC 8260  
 Test Item : Peak Power Output Data  
 Test Site : No.3 OATS  
 Test Mode : Mode 4 Beamforming: Transmit - 802.11n-20BW\_14.4Mbps(5G Band)

**Chain A**

Channel No	Frequency (MHz)	Average Power For different Data Rate (Mbps)									Peak Power	Required Limit	Result
		HT8	HT9	HT10	HT11	HT12	HT13	HT14	HT15	HT8			
		Measurement Level (dBm)											
149	5745	17.98	--	--	--	--	--	--	--	22.43	<30dBm	Pass	
157	5785	17.88	17.75	17.65	17.53	17.48	17.34	17.22	17.16	22.41	<30dBm	Pass	
165	5825	17.92	--	--	--	--	--	--	--	22.39	<30dBm	Pass	

Note: Peak Power Output Value =Reading value on power meter + cable loss

**Chain B**

Channel No	Frequency (MHz)	Average Power For different Data Rate (Mbps)									Peak Power	Required Limit	Result
		HT8	HT9	HT10	HT11	HT12	HT13	HT14	HT15	HT8			
		Measurement Level (dBm)											
149	5745	17.88	--	--	--	--	--	--	--	22.36	<30dBm	Pass	
157	5785	17.89	17.73	17.68	17.54	17.52	17.46	17.36	17.29	22.39	<30dBm	Pass	
165	5825	17.79	--	--	--	--	--	--	--	22.38	<30dBm	Pass	

Note: Peak Power Output Value =Reading value on power meter + cable loss

**CHAIN A+B**

Channel	Frequency (MHz)	Data Rata (Mbps)	Chain A Power (dBm)	Chain B Power (dBm)	Chain A+B Power (dBm)	Limit (dBm)	Result
149	5745	HT8	22.43	22.36	25.41	<30dBm	Pass
157	5785	HT8	22.41	22.39	25.41	<30dBm	Pass
165	5825	HT8	22.39	22.38	25.40	<30dBm	Pass

Note: Peak Power Output Value (dBm) = 10\*LOG (Chain A (mW)+ Chain B (mW))

Product : Intel® Dual Band Wireless-AC 8260  
 Test Item : Peak Power Output Data  
 Test Site : No.3 OATS  
 Test Mode : Mode 4 Beamforming: Transmit - 802.11n-40BW\_30Mbps(5G Band)

**Chain A**

Channel No	Frequency (MHz)	Average Power For different Data Rate (Mbps)									Peak Power	Required Limit	Result
		HT8	HT9	HT10	HT11	HT12	HT13	HT14	HT15	HT8			
		Measurement Level (dBm)											
151	5755	18.75	--	--	--	--	--	--	--	22.19	<30dBm	Pass	
159	5795	18.75	18.66	18.57	18.43	18.34	18.27	18.14	18.08	22.22	<30dBm	Pass	

Note: Peak Power Output Value =Reading value on power meter + cable loss

**Chain B**

Channel No	Frequency (MHz)	Average Power For different Data Rate (Mbps)									Peak Power	Required Limit	Result
		HT8	HT9	HT10	HT11	HT12	HT13	HT14	HT15	HT8			
		Measurement Level (dBm)											
151	5755	17.89	--	--	--	--	--	--	--	22.06	<30dBm	Pass	
159	5795	17.86	17.74	17.63	17.52	17.41	17.32	17.29	17.11	22.19	<30dBm	Pass	

Note: Peak Power Output Value =Reading value on power meter + cable loss

**CHAIN A+B**

Channel	Frequency (MHz)	Data Rata (Mbps)	Chain A Power (dBm)	Chain B Power (dBm)	Chain A+B Power (dBm)	Limit (dBm)	Result
151	5755	HT8	22.19	22.06	25.14	<30dBm	Pass
159	5795	HT8	22.22	22.19	25.22	<30dBm	Pass

Note: Peak Power Output Value (dBm) = 10\*LOG (Chain A (mW)+ Chain B (mW))

Product : Intel® Dual Band Wireless-AC 8260  
 Test Item : Peak Power Output Data  
 Test Site : No.3 OATS  
 Test Mode : Mode 4 Beamforming: Transmit - 802.11ac-80BW\_65Mbps(5G Band)

**Chain A**

Channel No	Frequency (MHz)	Average Power For different Data Rate (Mbps)									Required Limit	Result
		VTH0	VTH1	VTH2	VTH3	VTH4	VTH5	VTH6	VTH7	VTH0		
		Average Power For different Data Rate (Mbps)										
155	5775	20.74	20.67	20.54	20.43	20.37	20.26	20.14	20.07	20.74	<30dBm	Pass

Note: Peak Power Output Value =Reading value on power meter + cable loss

**Chain B**

Channel No	Frequency (MHz)	Average Power For different Data Rate (Mbps)									Required Limit	Result
		VTH0	VTH1	VTH2	VTH3	VTH4	VTH5	VTH6	VTH7	VTH0		
		Average Power For different Data Rate (Mbps)										
155	5775	20.83	20.74	20.68	20.54	20.46	20.34	20.21	20.18	20.88	<30dBm	Pass

Note: Peak Power Output Value =Reading value on power meter + cable loss

**(CHAIN A+ B)**

Channel Number	Frequency (MHz)	Data Rata (Mbps)	Chain A Power (dBm)	Chain B Power (dBm)	Output Power (dBm)	Output Power Limit
						(dBm)
155	5775	VTH0	20.74	20.83	23.79	30

Note:

1. Power Output Value =Reading value on average power meter + cable loss
2. Output Power (dBm) = 10LOG (Chain A Power (mW)+ Chain B Power (mW))

Figure Channel 155: (Chain A)

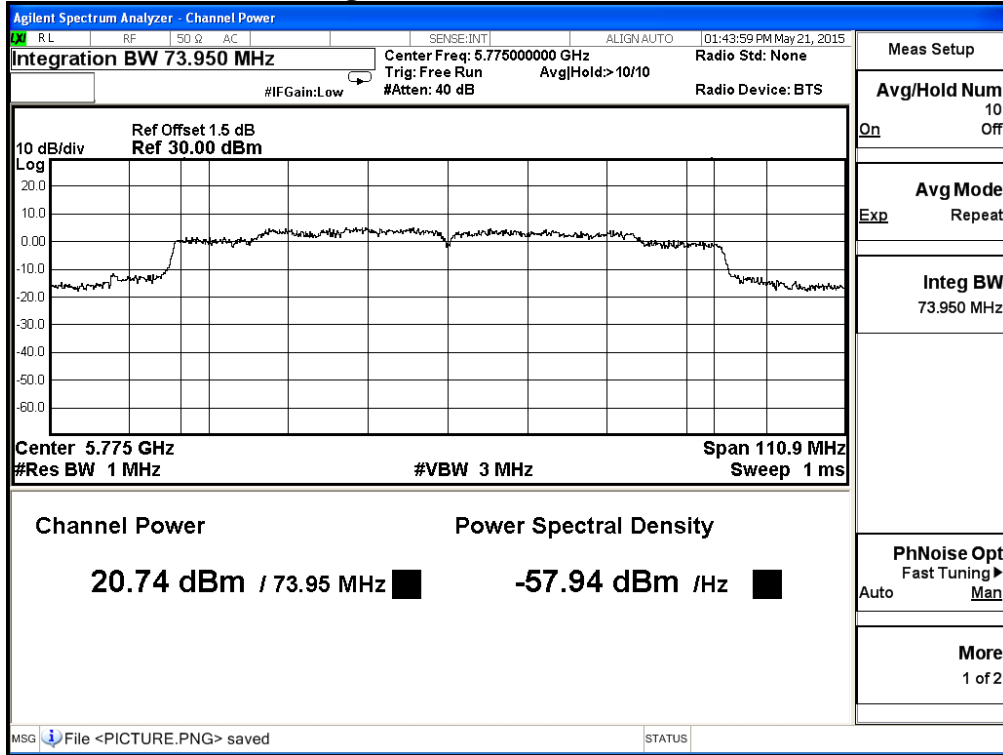
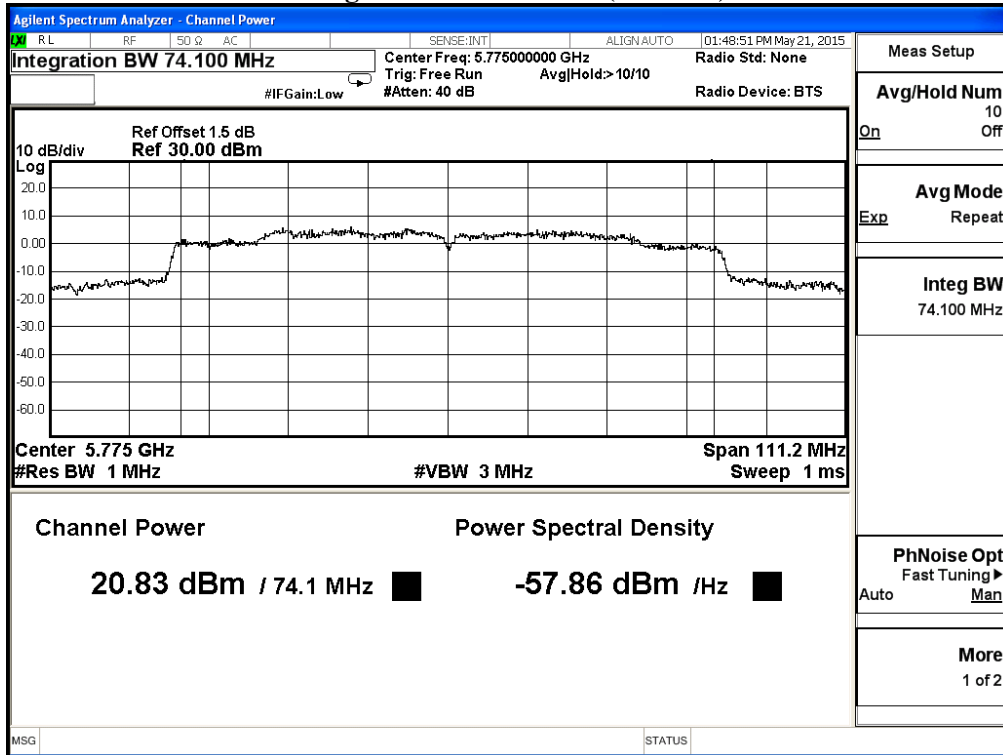

Figure Channel 155: (Chain B)



#### 4. Radiated Emission

##### 4.1. Test Equipment

The following test equipments are used during the radiated emission test:

Test Site		Equipment	Manufacturer	Model No./Serial No.	Last Cal.
☒ Site # 3	X	Magnetic Loop Antenna	Teseq	HLA6121/ 37133	Sep, 2014
	X	Bilog Antenna	Schaffner Chase	CBL6112B/ 2707	Jun, 2014
	X	EMI Test Receiver	R&S	ESCS 30/838251/ 001	Jun, 2014
	X	Coaxial Cable	QTK(Armist)	RG 214/ LC003-RG	Jun, 2014
	X	Coaxial signal switch	Armist	MP59B/ 6200798682	Jun, 2014

Test Site		Equipment	Manufacturer	Model No./Serial No.	Last Cal.
☒ CB # 8	X	Spectrum Analyzer	R&S	FSP40/ 100339	Oct, 2014
	X	Horn Antenna	ETS-Lindgren	3117/ 35205	Mar., 2015
	X	Horn Antenna	Schwarzbeck	BBHA9170/209	Jan, 2015
	X	Horn Antenna	TRC	AH-0801/95051	Aug, 2014
	X	Pre-Amplifier	EMCI	EMC012630SE/980210	Jan, 2015
	X	Pre-Amplifier	MITEQ	JS41-001040000-58-5P/153945	Jul, 2014
	X	Pre-Amplifier	NARDA	DBL-1840N506/013	Jul, 2014

- Note:
1. All equipments are calibrated with traceable calibrations. Each calibration is traceable to the national or international standards.
  2. The test instruments marked with "X" are used to measure the final test results.

## 4.2. Test Setup

### Radiated Emission Below 1GHz

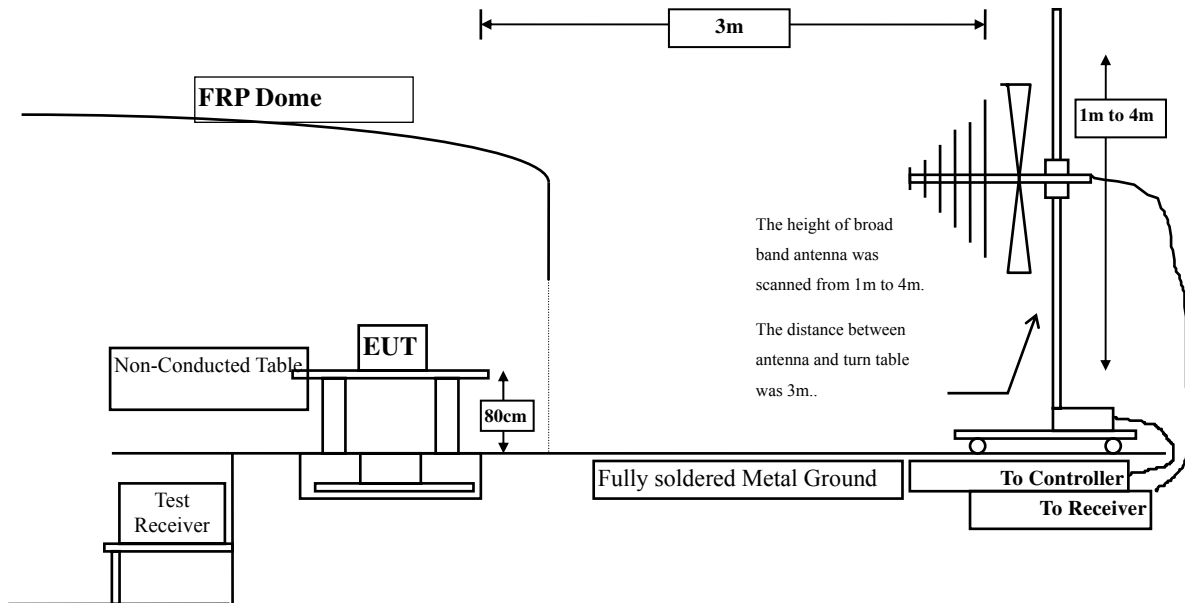

### Radiated Emission Above 1GHz

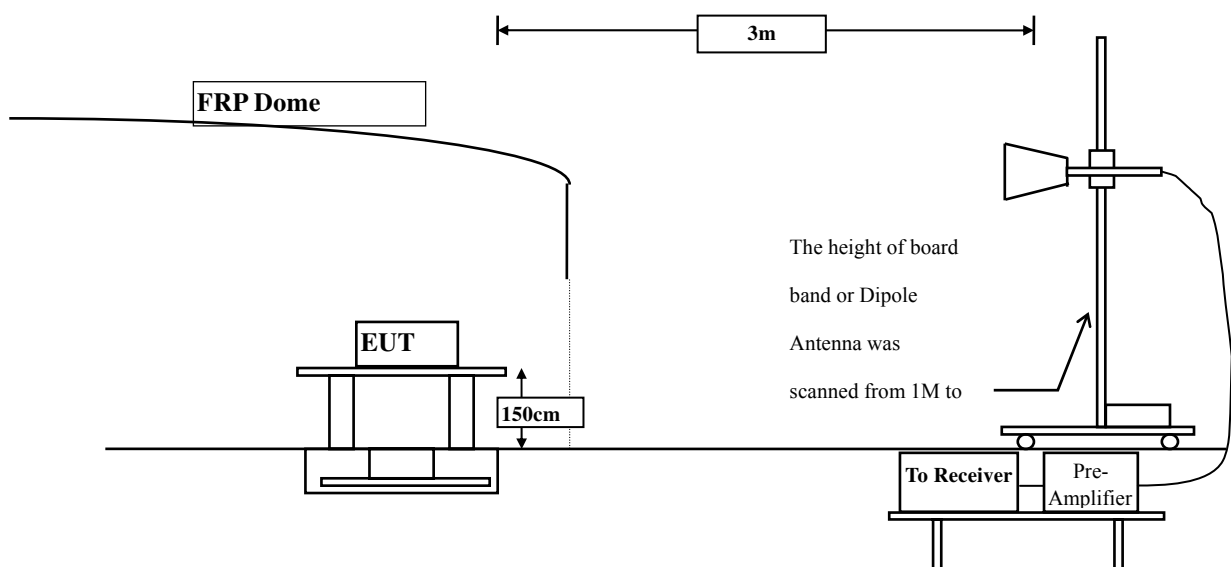

**4.3. Limits**

Emissions radiated outside of the specified frequency bands, except for harmonics, shall be attenuated by at least 20dB below the level of the fundamental or to the general radiated emission limits in paragraph 15.209, whichever is the lesser attenuation.

<b>FCC Part 15 Subpart C Paragraph 15.209(a) Limits</b>		
Frequency MHz	Field strength (microvolts/meter)	Measurement distance (meter)
0.009-0.490	2400/F(kHz)	300
0.490-1.705	24000/F(kHz)	30
1.705-30	30	30
30-88	100	3
88-216	150	3
216-960	200	3
Above 960	500	3

Remarks: E field strength (dBuV/m) = 20 log E field strength (uV/m)



#### **4.4. Test Procedure**

The EUT was setup according to ANSI C63.10: 2009 and tested according to DTS test procedure of KDB558074 for compliance to FCC 47CFR 15.247 requirements.

Measuring the frequency range below 1GHz, the EUT is placed on a turn table which is 0.8 meter above ground, when measuring the frequency range above 1GHz, the EUT is placed on a turn table which is 1.5 meter above ground.

The turn table is rotated 360 degrees to determine the position of the maximum emission level.

The EUT was positioned such that the distance from antenna to the EUT was 3 meters.

The antenna is scanned between 1 meter and 4 meters to find out the maximum emission level. This is repeated for both horizontal and vertical polarization of the antenna. In order to find the maximum emission, all of the interface cables were manipulated according to ANSI C63.10: 2009 on radiated measurement.

The resolution bandwidth below 30MHz setting on the field strength meter is 9kHz and 30MHz~1GHz is 120kHz and above 1GHz is 1MHz.

Radiated emission measurements below 30MHz are made using Loop Antenna and 30MHz~1GHz are made using broadband Bilog antenna and above 1GHz are made using Horn Antennas.

The measurement is divided into the Preliminary Measurement and the Final Measurement.

The suspected frequencies are searched for in Preliminary Measurement with the measurement antenna kept pointed at the source of the emission both in azimuth and elevation, with the polarization of the antenna oriented for maximum response. The antenna is pointed at an angle towards the source of the emission, and the EUT is rotated in both height and polarization to maximize the measured emission. The emission is kept within the illumination area of the 3 dB bandwidth of the antenna.

The worst radiated emission is measured in the Open Area Test Site on the Final Measurement.

The measurement frequency range from 9kHz - 10th Harmonic of fundamental was investigated.

#### **4.5. Uncertainty**

± 3.9 dB above 1GHz

± 3.8 dB below 1GHz

**4.6. Test Result of Radiated Emission**

Product : Intel® Dual Band Wireless-AC 8260  
 Test Item : Harmonic Radiated Emission Data  
 Test Site : No.3 OATS  
 Test Mode : Mode 1 SISO A: Transmit (802.11b 1Mbps) (2412MHz)

Frequency MHz	Correct Factor dB	Reading Level dBuV	Measurement Level dBuV/m	Margin dB	Limit dBuV/m
<b>Horizontal</b>					
<b>Peak Detector:</b>					
4824.000	3.261	39.280	42.541	-31.459	74.000
7236.000	10.650	37.060	47.710	-26.290	74.000
9648.000	13.337	37.180	50.516	-23.484	74.000
<b>Average Detector:</b>					
--					
<b>Vertical</b>					
<b>Peak Detector:</b>					
4824.000	6.421	42.260	48.681	-25.319	74.000
7236.000	11.495	35.890	47.385	-26.615	74.000
9648.000	13.807	37.250	51.056	-22.944	74.000
<b>Average Detector:</b>					
--					

Note:

1. All Readings below 1GHz are Quasi-Peak, above 1GHz are performed with peak and/or average measurements as necessary.
2. Peak measurements: RBW = 1MHz, VBW = 3 MHz, Sweep: Auto.
3. Average measurements: RBW = 1MHz, VBW = 10 Hz, Sweep: Auto.
4. Measurement Level = Reading Level + Correct Factor.
5. Correct Factor = Antenna factor + Cable loss – Amplifier gain.
6. The average measurement was not performed when the peak measured data under the limit of average detection.
7. The emission levels of other frequencies are very lower than the limit and not show in test report.

Product : Intel® Dual Band Wireless-AC 8260  
 Test Item : Harmonic Radiated Emission Data  
 Test Site : No.3 OATS  
 Test Mode : Mode 1 SISO A: Transmit (802.11b 1Mbps) (2437 MHz)

Frequency MHz	Correct Factor dB	Reading Level dBuV	Measurement Level dBuV/m	Margin dB	Limit dBuV/m
<b>Horizontal</b>					
<b>Peak Detector:</b>					
4874.000	3.038	39.480	42.517	-31.483	74.000
7311.000	11.795	36.670	48.464	-25.536	74.000
9748.000	12.635	37.340	49.975	-24.025	74.000
<b>Average Detector:</b>					
--					
<b>Vertical</b>					
<b>Peak Detector:</b>					
4874.000	5.812	42.030	47.841	-26.159	74.000
7311.000	12.630	37.640	50.269	-23.731	74.000
9748.000	13.126	36.970	50.096	-23.904	74.000
<b>Average Detector:</b>					
--					

Note:

1. All Readings below 1GHz are Quasi-Peak, above 1GHz are performed with peak and/or average measurements as necessary.
2. Peak measurements: RBW = 1MHz, VBW = 3 MHz, Sweep: Auto.
3. Average measurements: RBW = 1MHz, VBW = 10 Hz, Sweep: Auto.
4. Measurement Level = Reading Level + Correct Factor.
5. Correct Factor = Antenna factor + Cable loss – Amplifier gain.
6. The average measurement was not performed when the peak measured data under the limit of average detection.
7. The emission levels of other frequencies are very lower than the limit and not show in test report.

Product : Intel® Dual Band Wireless-AC 8260  
 Test Item : Harmonic Radiated Emission Data  
 Test Site : No.3 OATS  
 Test Mode : Mode 1 SISO A: Transmit (802.11b 1Mbps) (2462 MHz)

Frequency MHz	Correct Factor dB	Reading Level dBuV	Measurement Level dBuV/m	Margin dB	Limit dBuV/m
<b>Horizontal</b>					
<b>Peak Detector:</b>					
4924.000	2.858	39.870	42.727	-31.273	74.000
7386.000	12.127	37.080	49.208	-24.792	74.000
9848.000	12.852	36.590	49.443	-24.557	74.000
<b>Average Detector:</b>					
--					
<b>Vertical</b>					
<b>Peak Detector:</b>					
4924.000	5.521	41.640	47.160	-26.840	74.000
7386.000	13.254	37.510	50.764	-23.236	74.000
9848.000	13.367	37.320	50.687	-23.313	74.000
<b>Average Detector:</b>					
--					

Note:

1. All Readings below 1GHz are Quasi-Peak, above 1GHz are performed with peak and/or average measurements as necessary.
2. Peak measurements: RBW = 1MHz, VBW = 3 MHz, Sweep: Auto.
3. Average measurements: RBW = 1MHz, VBW = 10 Hz, Sweep: Auto.
4. Measurement Level = Reading Level + Correct Factor.
5. Correct Factor = Antenna factor + Cable loss – Amplifier gain.
6. The average measurement was not performed when the peak measured data under the limit of average detection.
7. The emission levels of other frequencies are very lower than the limit and not show in test report.

Product : Intel® Dual Band Wireless-AC 8260  
 Test Item : Harmonic Radiated Emission Data  
 Test Site : No.3 OATS  
 Test Mode : Mode 1 SISO A: Transmit (802.11b 1Mbps) (2467 MHz)

Frequency MHz	Correct Factor dB	Reading Level dBuV	Measurement Level dBuV/m	Margin dB	Limit dBuV/m
<b>Horizontal</b>					
<b>Peak Detector:</b>					
4934.000	2.830	37.450	40.281	-33.719	74.000
7401.000	12.218	36.650	48.868	-25.132	74.000
9868.000	13.043	36.480	49.522	-24.478	74.000
<b>Average Detector:</b>					
--					
<b>Vertical</b>					
<b>Peak Detector:</b>					
4934.000	5.530	37.550	43.081	-30.919	74.000
7401.000	13.345	36.750	50.096	-23.904	74.000
9868.000	13.602	36.530	50.131	-23.869	74.000
<b>Average Detector:</b>					
--					

Note:

1. All Readings below 1GHz are Quasi-Peak, above 1GHz are performed with peak and/or average measurements as necessary.
2. Peak measurements: RBW = 1MHz, VBW = 3 MHz, Sweep: Auto.
3. Average measurements: RBW = 1MHz, VBW = 10 Hz, Sweep: Auto.
4. Measurement Level = Reading Level + Correct Factor.
5. Correct Factor = Antenna factor + Cable loss – Amplifier gain.
6. The average measurement was not performed when the peak measured data under the limit of average detection.
7. The emission levels of other frequencies are very lower than the limit and not show in test report.

Product : Intel® Dual Band Wireless-AC 8260  
 Test Item : Harmonic Radiated Emission Data  
 Test Site : No.3 OATS  
 Test Mode : Mode 1 SISO A: Transmit (802.11g 6Mbps) (2412MHz)

Frequency MHz	Correct Factor dB	Reading Level dBuV	Measurement Level dBuV/m	Margin dB	Limit dBuV/m
<b>Horizontal</b>					
<b>Peak Detector:</b>					
4824.000	3.261	39.620	42.881	-31.119	74.000
7236.000	10.650	39.310	49.960	-24.040	74.000
9648.000	13.337	37.140	50.476	-23.524	74.000
<b>Average Detector:</b>					
--					
<b>Vertical</b>					
<b>Peak Detector:</b>					
4824.000	6.421	40.990	47.411	-26.589	74.000
7236.000	11.495	38.840	50.335	-23.665	74.000
9648.000	13.807	36.710	50.516	-23.484	74.000
<b>Average Detector:</b>					
--					

Note:

1. All Readings below 1GHz are Quasi-Peak, above 1GHz are performed with peak and/or average measurements as necessary.
2. Peak measurements: RBW = 1MHz, VBW = 3 MHz, Sweep: Auto.
3. Average measurements: RBW = 1MHz, VBW = 10 Hz, Sweep: Auto.
4. Measurement Level = Reading Level + Correct Factor.
5. Correct Factor = Antenna factor + Cable loss – Amplifier gain.
6. The average measurement was not performed when the peak measured data under the limit of average detection.
7. The emission levels of other frequencies are very lower than the limit and not show in test report.

Product : Intel® Dual Band Wireless-AC 8260  
 Test Item : Harmonic Radiated Emission Data  
 Test Site : No.3 OATS  
 Test Mode : Mode 1 SISO A: Transmit (802.11g 6Mbps) (2437 MHz)

Frequency MHz	Correct Factor dB	Reading Level dBuV	Measurement Level dBuV/m	Margin dB	Limit dBuV/m
<b>Horizontal</b>					
<b>Peak Detector:</b>					
4874.000	3.038	39.660	42.697	-31.303	74.000
7311.000	11.795	39.250	51.044	-22.956	74.000
9748.000	12.635	37.270	49.905	-24.095	74.000
<b>Average Detector:</b>					
--					
<b>Vertical</b>					
<b>Peak Detector:</b>					
4874.000	5.812	41.190	47.001	-26.999	74.000
7311.000	12.630	39.240	51.869	-22.131	74.000
9748.000	13.126	36.750	49.876	-24.124	74.000
<b>Average Detector:</b>					
--					

Note:

1. All Readings below 1GHz are Quasi-Peak, above 1GHz are performed with peak and/or average measurements as necessary.
2. Peak measurements: RBW = 1MHz, VBW = 3 MHz, Sweep: Auto.
3. Average measurements: RBW = 1MHz, VBW = 10 Hz, Sweep: Auto.
4. Measurement Level = Reading Level + Correct Factor.
5. Correct Factor = Antenna factor + Cable loss – Amplifier gain.
6. The average measurement was not performed when the peak measured data under the limit of average detection.
7. The emission levels of other frequencies are very lower than the limit and not show in test report.

Product : Intel® Dual Band Wireless-AC 8260  
 Test Item : Harmonic Radiated Emission Data  
 Test Site : No.3 OATS  
 Test Mode : Mode 1 SISO A: Transmit (802.11g 6Mbps) (2462 MHz)

Frequency MHz	Correct Factor dB	Reading Level dBuV	Measurement Level dBuV/m	Margin dB	Limit dBuV/m
<b>Horizontal</b>					
<b>Peak Detector:</b>					
4924.000	2.858	39.440	42.297	-31.703	74.000
7386.000	12.127	40.060	52.188	-21.812	74.000
9848.000	12.852	37.110	49.963	-24.037	74.000
<b>Average Detector:</b>					
--					
<b>Vertical</b>					
<b>Peak Detector:</b>					
4924.000	5.521	41.090	46.610	-27.390	74.000
7386.000	13.254	39.580	52.834	-21.166	74.000
9848.000	13.367	36.940	50.307	-23.693	74.000
<b>Average Detector:</b>					
--					

Note:

1. All Readings below 1GHz are Quasi-Peak, above 1GHz are performed with peak and/or average measurements as necessary.
2. Peak measurements: RBW = 1MHz, VBW = 3 MHz, Sweep: Auto.
3. Average measurements: RBW = 1MHz, VBW = 10 Hz, Sweep: Auto.
4. Measurement Level = Reading Level + Correct Factor.
5. Correct Factor = Antenna factor + Cable loss – Amplifier gain.
6. The average measurement was not performed when the peak measured data under the limit of average detection.
7. The emission levels of other frequencies are very lower than the limit and not show in test report.



Product : Intel® Dual Band Wireless-AC 8260  
 Test Item : Harmonic Radiated Emission Data  
 Test Site : No.3 OATS  
 Test Mode : Mode 1 SISO A: Transmit (802.11g 6Mbps) (2467 MHz)

Frequency MHz	Correct Factor dB	Reading Level dBuV	Measurement Level dBuV/m	Margin dB	Limit dBuV/m
<b>Horizontal</b>					
<b>Peak Detector:</b>					
4934.000	2.830	37.480	40.311	-33.689	74.000
7401.000	12.218	36.710	48.928	-25.072	74.000
9868.000	13.043	36.480	49.522	-24.478	74.000
<b>Average Detector:</b>					
--					
<b>Vertical</b>					
<b>Peak Detector:</b>					
4934.000	5.530	37.750	43.281	-30.719	74.000
7401.000	13.345	36.720	50.066	-23.934	74.000
9868.000	13.602	36.570	50.171	-23.829	74.000
<b>Average Detector:</b>					
--					

Note:

1. All Readings below 1GHz are Quasi-Peak, above 1GHz are performed with peak and/or average measurements as necessary.
2. Peak measurements: RBW = 1MHz, VBW = 3 MHz, Sweep: Auto.
3. Average measurements: RBW = 1MHz, VBW = 10 Hz, Sweep: Auto.
4. Measurement Level = Reading Level + Correct Factor.
5. Correct Factor = Antenna factor + Cable loss – Amplifier gain.
6. The average measurement was not performed when the peak measured data under the limit of average detection.
7. The emission levels of other frequencies are very lower than the limit and not show in test report.

Product : Intel® Dual Band Wireless-AC 8260  
 Test Item : Harmonic Radiated Emission Data  
 Test Site : No.3 OATS  
 Test Mode : Mode 1 SISO A: Transmit - 802.11a 6Mbps (5745 MHz)

Frequency	Correct	Reading	Measurement	Margin	Limit
MHz	Factor	Level	Level	dB	dBuV/m
	dB	dBuV	dBuV/m		

**Horizontal**

**Peak Detector:**

11490.000	17.106	35.610	52.717	-21.283	74.000
-----------	--------	--------	--------	---------	--------

**Average**

**Detector:**

--

**Vertical**

**Peak Detector:**

11490.000	18.034	35.550	53.585	-20.415	74.000
-----------	--------	--------	--------	---------	--------

**Average**

**Detector:**

--

Note:

1. All Readings below 1GHz are Quasi-Peak, above 1GHz are performed with peak and/or average measurements as necessary.
2. Peak measurements: RBW = 1MHz, VBW = 3 MHz, Sweep: Auto.
3. Average measurements: RBW = 1MHz, VBW = 10 Hz, Sweep: Auto.
4. Measurement Level = Reading Level + Correct Factor.
5. Correct Factor = Antenna factor + Cable loss – Amplifier gain.
6. The average measurement was not performed when the peak measured data under the limit of average detection.
7. The emission levels of other frequencies are very lower than the limit and not show in test report.

Product : Intel® Dual Band Wireless-AC 8260  
 Test Item : Harmonic Radiated Emission Data  
 Test Site : No.3 OATS  
 Test Mode : Mode 1 SISO A: Transmit - 802.11a 6Mbps (5785 MHz)

Frequency MHz	Correct Factor dB	Reading Level dBuV	Measurement Level dBuV/m	Margin dB	Limit dBuV/m
------------------	-------------------------	--------------------------	--------------------------------	--------------	-----------------

**Horizontal**

**Peak Detector:**

11570.000	16.809	35.490	52.299	-21.701	74.000
-----------	--------	--------	--------	---------	--------

**Average**

**Detector:**

--

**Vertical**

**Peak Detector:**

11570.000	17.698	36.120	53.818	-20.182	74.000
-----------	--------	--------	--------	---------	--------

**Average**

**Detector:**

--

Note:

1. All Readings below 1GHz are Quasi-Peak, above 1GHz are performed with peak and/or average measurements as necessary.
2. Peak measurements: RBW = 1MHz, VBW = 3 MHz, Sweep: Auto.
3. Average measurements: RBW = 1MHz, VBW = 10 Hz, Sweep: Auto.
4. Measurement Level = Reading Level + Correct Factor.
5. Correct Factor = Antenna factor + Cable loss – Amplifier gain.
6. The average measurement was not performed when the peak measured data under the limit of average detection.
7. The emission levels of other frequencies are very lower than the limit and not show in test report.

Product : Intel® Dual Band Wireless-AC 8260  
Test Item : Harmonic Radiated Emission Data  
Test Site : No.3 OATS  
Test Mode : Mode 1 SISO A: Transmit - 802.11a 6Mbps (5825 MHz)

Frequency MHz	Correct Factor dB	Reading Level dBuV	Measurement Level dBuV/m	Margin dB	Limit dBuV/m
<b>Horizontal</b>					
<b>Peak Detector:</b>					
11650.000	16.158	35.670	51.828	-22.172	74.000
<b>Average Detector:</b>					
--					
<b>Vertical</b>					
<b>Peak Detector:</b>					
11650.000	17.274	35.430	52.705	-21.295	74.000
<b>Average Detector:</b>					
--					

Note:

1. All Readings below 1GHz are Quasi-Peak, above 1GHz are performed with peak and/or average measurements as necessary.
2. Peak measurements: RBW = 1MHz, VBW = 3 MHz, Sweep: Auto.
3. Average measurements: RBW = 1MHz, VBW = 10 Hz, Sweep: Auto.
4. Measurement Level = Reading Level + Correct Factor.
5. Correct Factor = Antenna factor + Cable loss – Amplifier gain.
6. The average measurement was not performed when the peak measured data under the limit of average detection.
7. The emission levels of other frequencies are very lower than the limit and not show in test report.

Product : Intel® Dual Band Wireless-AC 8260  
 Test Item : Harmonic Radiated Emission Data  
 Test Site : No.3 OATS  
 Test Mode : Mode 1 SISO A: Transmit - 802.11n-20BW\_7.2Mbps(2.4G Band) (2412MHz)

Frequency MHz	Correct Factor dB	Reading Level dBuV	Measurement Level dBuV/m	Margin dB	Limit dBuV/m
<b>Horizontal</b>					
<b>Peak Detector:</b>					
4824.000	3.261	38.510	41.771	-32.229	74.000
7236.000	10.650	39.640	50.290	-23.710	74.000
9648.000	13.337	37.320	50.656	-23.344	74.000
<b>Average Detector:</b>					
--					
<b>Vertical</b>					
<b>Peak Detector:</b>					
4824.000	6.421	40.210	46.631	-27.369	74.000
7236.000	11.495	38.240	49.735	-24.265	74.000
9648.000	13.807	37.090	50.896	-23.104	74.000
<b>Average Detector:</b>					
--					

Note:

1. All Readings below 1GHz are Quasi-Peak, above 1GHz are performed with peak and/or average measurements as necessary.
2. Peak measurements: RBW = 1MHz, VBW = 3 MHz, Sweep: Auto.
3. Average measurements: RBW = 1MHz, VBW = 10 Hz, Sweep: Auto.
4. Measurement Level = Reading Level + Correct Factor.
5. Correct Factor = Antenna factor + Cable loss – Amplifier gain.
6. The average measurement was not performed when the peak measured data under the limit of average detection.
7. The emission levels of other frequencies are very lower than the limit and not show in test report.

Product : Intel® Dual Band Wireless-AC 8260  
 Test Item : Harmonic Radiated Emission Data  
 Test Site : No.3 OATS  
 Test Mode : Mode 1 SISO A: Transmit - 802.11n-20BW\_7.2Mbps(2.4G Band) (2437 MHz)

Frequency MHz	Correct Factor dB	Reading Level dBuV	Measurement Level dBuV/m	Margin dB	Limit dBuV/m
------------------	-------------------------	--------------------------	--------------------------------	--------------	-----------------

**Horizontal**

**Peak Detector:**

4874.000	3.038	38.480	41.517	-32.483	74.000
7311.000	11.795	39.470	51.264	-22.736	74.000
9748.000	12.635	36.750	49.385	-24.615	74.000

**Average  
Detector:**

--

**Vertical**

**Peak Detector:**

4874.000	5.812	40.660	46.471	-27.529	74.000
7311.000	12.630	38.150	50.779	-23.221	74.000
9748.000	13.126	36.470	49.596	-24.404	74.000

**Average  
Detector:**

--

Note:

1. All Readings below 1GHz are Quasi-Peak, above 1GHz are performed with peak and/or average measurements as necessary.
2. Peak measurements: RBW = 1MHz, VBW = 3 MHz, Sweep: Auto.
3. Average measurements: RBW = 1MHz, VBW = 10 Hz, Sweep: Auto.
4. Measurement Level = Reading Level + Correct Factor.
5. Correct Factor = Antenna factor + Cable loss –Amplifier gain.
6. The average measurement was not performed when the peak measured data under the limit of average detection.
7. The emission levels of other frequencies are very lower than the limit and not show in test report.

Product : Intel® Dual Band Wireless-AC 8260  
 Test Item : Harmonic Radiated Emission Data  
 Test Site : No.3 OATS  
 Test Mode : Mode 1 SISO A: Transmit - 802.11n-20BW\_7.2Mbps(2.4G Band) (2462 MHz)

Frequency MHz	Correct Factor dB	Reading Level dBuV	Measurement Level dBuV/m	Margin dB	Limit dBuV/m
<b>Horizontal</b>					
<b>Peak Detector:</b>					
4924.000	2.858	38.380	41.237	-32.763	74.000
7386.000	12.127	39.480	51.608	-22.392	74.000
9848.000	12.852	37.590	50.443	-23.557	74.000
<b>Average Detector:</b>					
--					
<b>Vertical</b>					
<b>Peak Detector:</b>					
4924.000	5.521	40.580	46.100	-27.900	74.000
7386.000	13.254	38.510	51.764	-22.236	74.000
9848.000	13.367	36.280	49.647	-24.353	74.000
<b>Average Detector:</b>					
--					

Note:

1. All Readings below 1GHz are Quasi-Peak, above 1GHz are performed with peak and/or average measurements as necessary.
2. Peak measurements: RBW = 1MHz, VBW = 3 MHz, Sweep: Auto.
3. Average measurements: RBW = 1MHz, VBW = 10 Hz, Sweep: Auto.
4. Measurement Level = Reading Level + Correct Factor.
5. Correct Factor = Antenna factor + Cable loss – Amplifier gain.
6. The average measurement was not performed when the peak measured data under the limit of average detection.
7. The emission levels of other frequencies are very lower than the limit and not show in test report.

Product : Intel® Dual Band Wireless-AC 8260  
 Test Item : Harmonic Radiated Emission Data  
 Test Site : No.3 OATS  
 Test Mode : Mode 1 SISO A: Transmit - 802.11n-20BW\_7.2Mbps(2.4G Band) (2467 MHz)

Frequency MHz	Correct Factor dB	Reading Level dBuV	Measurement Level dBuV/m	Margin dB	Limit dBuV/m
<b>Horizontal</b>					
<b>Peak Detector:</b>					
4934.000	2.830	37.680	40.511	-33.489	74.000
7401.000	12.218	36.870	49.088	-24.912	74.000
9868.000	13.043	36.520	49.562	-24.438	74.000
<b>Average Detector:</b>					
--					
<b>Vertical</b>					
<b>Peak Detector:</b>					
4934.000	5.530	37.670	43.201	-30.799	74.000
7401.000	13.345	36.680	50.026	-23.974	74.000
9868.000	13.602	36.510	50.111	-23.889	74.000
<b>Average Detector:</b>					
--					

Note:

1. All Readings below 1GHz are Quasi-Peak, above 1GHz are performed with peak and/or average measurements as necessary.
2. Peak measurements: RBW = 1MHz, VBW = 3 MHz, Sweep: Auto.
3. Average measurements: RBW = 1MHz, VBW = 10 Hz, Sweep: Auto.
4. Measurement Level = Reading Level + Correct Factor.
5. Correct Factor = Antenna factor + Cable loss – Amplifier gain.
6. The average measurement was not performed when the peak measured data under the limit of average detection.
7. The emission levels of other frequencies are very lower than the limit and not show in test report.



Product : Intel® Dual Band Wireless-AC 8260  
 Test Item : Harmonic Radiated Emission Data  
 Test Site : No.3 OATS  
 Test Mode : Mode 1 SISO A: Transmit - 802.11n-40BW\_15Mbps(2.4G Band) (2422MHz)

Frequency MHz	Correct Factor dB	Reading Level dBuV	Measurement Level dBuV/m	Margin dB	Limit dBuV/m
<b>Horizontal</b>					
<b>Peak Detector:</b>					
4844.000	3.171	38.480	41.651	-32.349	74.000
7266.000	11.162	37.120	48.282	-25.718	74.000
9688.000	12.964	36.580	49.545	-24.455	74.000
<b>Average Detector:</b>					
--					
<b>Vertical</b>					
<b>Peak Detector:</b>					
4844.000	6.178	38.780	44.958	-29.042	74.000
7266.000	11.982	36.740	48.722	-25.278	74.000
9688.000	13.507	36.690	50.198	-23.802	74.000
<b>Average Detector:</b>					
--					

Note:

1. All Readings below 1GHz are Quasi-Peak, above 1GHz are performed with peak and/or average measurements as necessary.
2. Peak measurements: RBW = 1MHz, VBW = 3 MHz, Sweep: Auto.
3. Average measurements: RBW = 1MHz, VBW = 10 Hz, Sweep: Auto.
4. Measurement Level = Reading Level + Correct Factor.
5. Correct Factor = Antenna factor + Cable loss – Amplifier gain.
6. The average measurement was not performed when the peak measured data under the limit of average detection.
7. The emission levels of other frequencies are very lower than the limit and not show in test report.

Product : Intel® Dual Band Wireless-AC 8260  
 Test Item : Harmonic Radiated Emission Data  
 Test Site : No.3 OATS  
 Test Mode : Mode 1 SISO A: Transmit - 802.11n-40BW\_15Mbps(2.4G Band) (2437 MHz)

Frequency MHz	Correct Factor dB	Reading Level dBuV	Measurement Level dBuV/m	Margin dB	Limit dBuV/m
<b>Horizontal</b>					
<b>Peak Detector:</b>					
4874.000	3.038	38.260	41.297	-32.703	74.000
7311.000	11.795	37.140	48.934	-25.066	74.000
9748.000	12.635	36.680	49.315	-24.685	74.000
<b>Average Detector:</b>					
--					
<b>Vertical</b>					
<b>Peak Detector:</b>					
4874.000	5.812	38.710	44.521	-29.479	74.000
7311.000	12.630	36.640	49.269	-24.731	74.000
9748.000	13.126	36.370	49.496	-24.504	74.000
<b>Average Detector:</b>					
--					

Note:

1. All Readings below 1GHz are Quasi-Peak, above 1GHz are performed with peak and/or average measurements as necessary.
2. Peak measurements: RBW = 1MHz, VBW = 3 MHz, Sweep: Auto.
3. Average measurements: RBW = 1MHz, VBW = 10 Hz, Sweep: Auto.
4. Measurement Level = Reading Level + Correct Factor.
5. Correct Factor = Antenna factor + Cable loss – Amplifier gain.
6. The average measurement was not performed when the peak measured data under the limit of average detection.
7. The emission levels of other frequencies are very lower than the limit and not show in test report.

Product : Intel® Dual Band Wireless-AC 8260  
 Test Item : Harmonic Radiated Emission Data  
 Test Site : No.3 OATS  
 Test Mode : Mode 1 SISO A: Transmit - 802.11n-40BW\_15Mbps(2.4G Band) (2452 MHz)

Frequency MHz	Correct Factor dB	Reading Level dBuV	Measurement Level dBuV/m	Margin dB	Limit dBuV/m
<b>Horizontal</b>					
<b>Peak Detector:</b>					
4904.000	2.914	38.840	41.755	-32.245	74.000
7356.000	11.995	37.540	49.534	-24.466	74.000
9808.000	12.475	37.110	49.585	-24.415	74.000
<b>Average Detector:</b>					
--					
<b>Vertical</b>					
<b>Peak Detector:</b>					
4904.000	5.530	40.670	46.201	-27.799	74.000
7356.000	13.005	38.490	51.494	-22.506	74.000
9808.000	12.901	36.340	49.241	-24.759	74.000
<b>Average Detector:</b>					
--					

Note:

1. All Readings below 1GHz are Quasi-Peak, above 1GHz are performed with peak and/or average measurements as necessary.
2. Peak measurements: RBW = 1MHz, VBW = 3 MHz, Sweep: Auto.
3. Average measurements: RBW = 1MHz, VBW = 10 Hz, Sweep: Auto.
4. Measurement Level = Reading Level + Correct Factor.
5. Correct Factor = Antenna factor + Cable loss – Amplifier gain.
6. The average measurement was not performed when the peak measured data under the limit of average detection.
7. The emission levels of other frequencies are very lower than the limit and not show in test report.

Product : Intel® Dual Band Wireless-AC 8260  
 Test Item : Harmonic Radiated Emission Data  
 Test Site : No.3 OATS  
 Test Mode : Mode 1 SISO A: Transmit - 802.11n-40BW\_15Mbps(2.4G Band) (2457 MHz)

Frequency MHz	Correct Factor dB	Reading Level dBuV	Measurement Level dBuV/m	Margin dB	Limit dBuV/m
<b>Horizontal</b>					
<b>Peak Detector:</b>					
4914.000	2.883	37.650	40.533	-33.467	74.000
7371.000	12.062	36.840	48.902	-25.098	74.000
9828.000	12.664	36.920	49.584	-24.416	74.000
<b>Average Detector:</b>					
--					
<b>Vertical</b>					
<b>Peak Detector:</b>					
4914.000	5.508	37.840	43.348	-30.652	74.000
7371.000	13.130	36.810	49.940	-24.060	74.000
9828.000	13.135	36.620	49.755	-24.245	74.000
<b>Average Detector:</b>					
--					

Note:

1. All Readings below 1GHz are Quasi-Peak, above 1GHz are performed with peak and/or average measurements as necessary.
2. Peak measurements: RBW = 1MHz, VBW = 3 MHz, Sweep: Auto.
3. Average measurements: RBW = 1MHz, VBW = 10 Hz, Sweep: Auto.
4. Measurement Level = Reading Level + Correct Factor.
5. Correct Factor = Antenna factor + Cable loss – Amplifier gain.
6. The average measurement was not performed when the peak measured data under the limit of average detection.
7. The emission levels of other frequencies are very lower than the limit and not show in test report.

Product : Intel® Dual Band Wireless-AC 8260  
Test Item : Harmonic Radiated Emission Data  
Test Site : No.3 OATS  
Test Mode : Mode 1 SISO A: Transmit - 802.11n-20BW\_7.2Mbps(5G Band) (5745MHz)

Frequency MHz	Correct Factor dB	Reading Level dBuV	Measurement Level dBuV/m	Margin dB	Limit dBuV/m
<b>Horizontal</b>					
<b>Peak Detector:</b>					
11490.000	17.106	35.140	52.247	-21.753	74.000
<b>Average Detector:</b>					
--					
<b>Vertical</b>					
<b>Peak Detector:</b>					
11490.000	18.034	35.310	53.345	-20.655	74.000
<b>Average Detector:</b>					
--					

Note:

1. All Readings below 1GHz are Quasi-Peak, above 1GHz are performed with peak and/or average measurements as necessary.
2. Peak measurements: RBW = 1MHz, VBW = 3 MHz, Sweep: Auto.
3. Average measurements: RBW = 1MHz, VBW = 10 Hz, Sweep: Auto.
4. Measurement Level = Reading Level + Correct Factor.
5. Correct Factor = Antenna factor + Cable loss –Amplifier gain.
6. The average measurement was not performed when the peak measured data under the limit of average detection.
7. The emission levels of other frequencies are very lower than the limit and not show in test report.

Product : Intel® Dual Band Wireless-AC 8260  
 Test Item : Harmonic Radiated Emission Data  
 Test Site : No.3 OATS  
 Test Mode : Mode 1 SISO A: Transmit - 802.11n-20BW\_7.2Mbps(5G Band) (5785 MHz)

Frequency MHz	Correct Factor dB	Reading Level dBuV	Measurement Level dBuV/m	Margin dB	Limit dBuV/m
<b>Horizontal</b>					
<b>Peak Detector:</b>					
11570.000	16.809	35.380	52.189	-21.811	74.000
<b>Average Detector:</b>					
--					
<b>Vertical</b>					
<b>Peak Detector:</b>					
11570.000	17.698	35.660	53.358	-20.642	74.000
<b>Average Detector:</b>					
--					

Note:

1. All Readings below 1GHz are Quasi-Peak, above 1GHz are performed with peak and/or average measurements as necessary.
2. Peak measurements: RBW = 1MHz, VBW = 3 MHz, Sweep: Auto.
3. Average measurements: RBW = 1MHz, VBW = 10 Hz, Sweep: Auto.
4. Measurement Level = Reading Level + Correct Factor.
5. Correct Factor = Antenna factor + Cable loss – Amplifier gain.
6. The average measurement was not performed when the peak measured data under the limit of average detection.
7. The emission levels of other frequencies are very lower than the limit and not show in test report.

Product : Intel® Dual Band Wireless-AC 8260  
 Test Item : Harmonic Radiated Emission Data  
 Test Site : No.3 OATS  
 Test Mode : Mode 1 SISO A: Transmit - 802.11n-20BW\_7.2Mbps(5G Band) (5825 MHz)

Frequency MHz	Correct Factor dB	Reading Level dBuV	Measurement Level dBuV/m	Margin dB	Limit dBuV/m
<b>Horizontal</b>					
<b>Peak Detector:</b>					
11650.000	16.158	35.470	51.628	-22.372	74.000
<b>Average Detector:</b>					
--					
<b>Vertical</b>					
<b>Peak Detector:</b>					
11650.000	17.274	35.540	52.815	-21.185	74.000
<b>Average Detector:</b>					
--					

Note:

1. All Readings below 1GHz are Quasi-Peak, above 1GHz are performed with peak and/or average measurements as necessary.
2. Peak measurements: RBW = 1MHz, VBW = 3 MHz, Sweep: Auto.
3. Average measurements: RBW = 1MHz, VBW = 10 Hz, Sweep: Auto.
4. Measurement Level = Reading Level + Correct Factor.
5. Correct Factor = Antenna factor + Cable loss – Amplifier gain.
6. The average measurement was not performed when the peak measured data under the limit of average detection.
7. The emission levels of other frequencies are very lower than the limit and not show in test report.

Product : Intel® Dual Band Wireless-AC 8260  
 Test Item : Harmonic Radiated Emission Data  
 Test Site : No.3 OATS  
 Test Mode : Mode 1 SISO A: Transmit - 802.11n-40BW\_15Mbps(5G Band) (5755MHz)

Frequency MHz	Correct Factor dB	Reading Level dBuV	Measurement Level dBuV/m	Margin dB	Limit dBuV/m
<b>Horizontal</b>					
<b>Peak Detector:</b>					
11510.000	17.124	35.520	52.644	-21.356	74.000
<b>Average Detector:</b>					
--					
<b>Vertical</b>					
<b>Peak Detector:</b>					
11510.000	18.081	35.430	53.511	-20.489	74.000
<b>Average Detector:</b>					
--					

Note:

1. All Readings below 1GHz are Quasi-Peak, above 1GHz are performed with peak and/or average measurements as necessary.
2. Peak measurements: RBW = 1MHz, VBW = 3 MHz, Sweep: Auto.
3. Average measurements: RBW = 1MHz, VBW = 10 Hz, Sweep: Auto.
4. Measurement Level = Reading Level + Correct Factor.
5. Correct Factor = Antenna factor + Cable loss – Amplifier gain.
6. The average measurement was not performed when the peak measured data under the limit of average detection.
7. The emission levels of other frequencies are very lower than the limit and not show in test report.



Product : Intel® Dual Band Wireless-AC 8260  
Test Item : Harmonic Radiated Emission Data  
Test Site : No.3 OATS  
Test Mode : Mode 1 SISO A: Transmit - 802.11n-40BW\_15Mbps(5G Band) (5795 MHz)

Frequency MHz	Correct Factor dB	Reading Level dBuV	Measurement Level dBuV/m	Margin dB	Limit dBuV/m
<b>Horizontal</b>					
<b>Peak Detector:</b>					
11590.000	16.701	35.760	52.460	-21.540	74.000
<b>Average Detector:</b>					
--					
<b>Vertical</b>					
<b>Peak Detector:</b>					
11590.000	17.567	35.410	52.976	-21.024	74.000
<b>Average Detector:</b>					
--					

Note:

1. All Readings below 1GHz are Quasi-Peak, above 1GHz are performed with peak and/or average measurements as necessary.
2. Peak measurements: RBW = 1MHz, VBW = 3 MHz, Sweep: Auto.
3. Average measurements: RBW = 1MHz, VBW = 10 Hz, Sweep: Auto.
4. Measurement Level = Reading Level + Correct Factor.
5. Correct Factor = Antenna factor + Cable loss – Amplifier gain.
6. The average measurement was not performed when the peak measured data under the limit of average detection.
7. The emission levels of other frequencies are very lower than the limit and not show in test report.

Product : Intel® Dual Band Wireless-AC 8260  
 Test Item : Harmonic Radiated Emission Data  
 Test Site : No.3 OATS  
 Test Mode : Mode 1 SISO A: Transmit - 802.11ac-80BW\_32.5Mbps(5G Band) (5775 MHz)

Frequency MHz	Correct Factor dB	Reading Level dBuV	Measurement Level dBuV/m	Margin dB	Limit dBuV/m
<b>Horizontal</b>					
<b>Peak Detector:</b>					
11530.000	17.018	35.970	52.989	-21.011	74.000
<b>Average Detector:</b>					
--					
<b>Vertical</b>					
<b>Peak Detector:</b>					
11530.000	17.952	35.310	53.263	-20.737	74.000
<b>Average Detector:</b>					
--					

Note:

1. All Readings below 1GHz are Quasi-Peak, above 1GHz are performed with peak and/or average measurements as necessary.
2. Peak measurements: RBW = 1MHz, VBW = 3 MHz, Sweep: Auto.
3. Average measurements: RBW = 1MHz, VBW = 10 Hz, Sweep: Auto.
4. Measurement Level = Reading Level + Correct Factor.
5. Correct Factor = Antenna factor + Cable loss – Amplifier gain.
6. The average measurement was not performed when the peak measured data under the limit of average detection.
7. The emission levels of other frequencies are very lower than the limit and not show in test report.

Product : Intel® Dual Band Wireless-AC 8260  
 Test Item : Harmonic Radiated Emission Data  
 Test Site : No.3 OATS  
 Test Mode : Mode 2 SISO B: Transmit (802.11b 1Mbps) (2412MHz)

Frequency MHz	Correct Factor dB	Reading Level dBuV	Measurement Level dBuV/m	Margin dB	Limit dBuV/m
<b>Horizontal</b>					
<b>Peak Detector:</b>					
4824.000	3.261	39.560	42.821	-31.179	74.000
7236.000	10.650	37.150	47.800	-26.200	74.000
9648.000	13.337	37.360	50.696	-23.304	74.000
<b>Average Detector:</b>					
--					
<b>Vertical</b>					
<b>Peak Detector:</b>					
4824.000	6.421	42.520	48.941	-25.059	74.000
7236.000	11.495	36.180	47.675	-26.325	74.000
9648.000	13.807	37.410	51.216	-22.784	74.000
<b>Average Detector:</b>					
--					

Note:

1. All Readings below 1GHz are Quasi-Peak, above 1GHz are performed with peak and/or average measurements as necessary.
2. Peak measurements: RBW = 1MHz, VBW = 3 MHz, Sweep: Auto.
3. Average measurements: RBW = 1MHz, VBW = 10 Hz, Sweep: Auto.
4. Measurement Level = Reading Level + Correct Factor.
5. Correct Factor = Antenna factor + Cable loss – Amplifier gain.
6. The average measurement was not performed when the peak measured data under the limit of average detection.
7. The emission levels of other frequencies are very lower than the limit and not show in test report.

Product : Intel® Dual Band Wireless-AC 8260  
 Test Item : Harmonic Radiated Emission Data  
 Test Site : No.3 OATS  
 Test Mode : Mode 2 SISO B: Transmit (802.11b 1Mbps) (2437 MHz)

Frequency MHz	Correct Factor dB	Reading Level dBuV	Measurement Level dBuV/m	Margin dB	Limit dBuV/m
<b>Horizontal</b>					
<b>Peak Detector:</b>					
4874.000	3.038	39.670	42.707	-31.293	74.000
7311.000	11.795	36.840	48.634	-25.366	74.000
9748.000	12.635	37.650	50.285	-23.715	74.000
<b>Average Detector:</b>					
--					
<b>Vertical</b>					
<b>Peak Detector:</b>					
4874.000	5.812	42.120	47.931	-26.069	74.000
7311.000	12.630	37.880	50.509	-23.491	74.000
9748.000	13.126	37.210	50.336	-23.664	74.000
<b>Average Detector:</b>					
--					

Note:

1. All Readings below 1GHz are Quasi-Peak, above 1GHz are performed with peak and/or average measurements as necessary.
2. Peak measurements: RBW = 1MHz, VBW = 3 MHz, Sweep: Auto.
3. Average measurements: RBW = 1MHz, VBW = 10 Hz, Sweep: Auto.
4. Measurement Level = Reading Level + Correct Factor.
5. Correct Factor = Antenna factor + Cable loss –Amplifier gain.
6. The average measurement was not performed when the peak measured data under the limit of average detection.
7. The emission levels of other frequencies are very lower than the limit and not show in test report.

Product : Intel® Dual Band Wireless-AC 8260  
 Test Item : Harmonic Radiated Emission Data  
 Test Site : No.3 OATS  
 Test Mode : Mode 2 SISO B: Transmit (802.11b 1Mbps) (2462 MHz)

Frequency MHz	Correct Factor dB	Reading Level dBuV	Measurement Level dBuV/m	Margin dB	Limit dBuV/m
<b>Horizontal</b>					
<b>Peak Detector:</b>					
4924.000	2.858	40.120	42.977	-31.023	74.000
7386.000	12.127	37.250	49.378	-24.622	74.000
9848.000	12.852	36.750	49.603	-24.397	74.000
<b>Average Detector:</b>					
--					
<b>Vertical</b>					
<b>Peak Detector:</b>					
4924.000	5.521	41.870	47.390	-26.610	74.000
7386.000	13.254	37.680	50.934	-23.066	74.000
9848.000	13.367	37.460	50.827	-23.173	74.000
<b>Average Detector:</b>					
--					

Note:

1. All Readings below 1GHz are Quasi-Peak, above 1GHz are performed with peak and/or average measurements as necessary.
2. Peak measurements: RBW = 1MHz, VBW = 3 MHz, Sweep: Auto.
3. Average measurements: RBW = 1MHz, VBW = 10 Hz, Sweep: Auto.
4. Measurement Level = Reading Level + Correct Factor.
5. Correct Factor = Antenna factor + Cable loss – Amplifier gain.
6. The average measurement was not performed when the peak measured data under the limit of average detection.
7. The emission levels of other frequencies are very lower than the limit and not show in test report.

Product : Intel® Dual Band Wireless-AC 8260  
 Test Item : Harmonic Radiated Emission Data  
 Test Site : No.3 OATS  
 Test Mode : Mode 2 SISO B: Transmit (802.11b 1Mbps) (2467 MHz)

Frequency MHz	Correct Factor dB	Reading Level dBuV	Measurement Level dBuV/m	Margin dB	Limit dBuV/m
<b>Horizontal</b>					
<b>Peak Detector:</b>					
4934.000	2.830	37.570	40.401	-33.599	74.000
7401.000	12.218	36.750	48.968	-25.032	74.000
9868.000	13.043	36.690	49.732	-24.268	74.000
<b>Average Detector:</b>					
--					
<b>Vertical</b>					
<b>Peak Detector:</b>					
4934.000	5.530	37.650	43.181	-30.819	74.000
7401.000	13.345	36.720	50.066	-23.934	74.000
9868.000	13.602	36.380	49.981	-24.019	74.000
<b>Average Detector:</b>					
--					

Note:

1. All Readings below 1GHz are Quasi-Peak, above 1GHz are performed with peak and/or average measurements as necessary.
2. Peak measurements: RBW = 1MHz, VBW = 3 MHz, Sweep: Auto.
3. Average measurements: RBW = 1MHz, VBW = 10 Hz, Sweep: Auto.
4. Measurement Level = Reading Level + Correct Factor.
5. Correct Factor = Antenna factor + Cable loss – Amplifier gain.
6. The average measurement was not performed when the peak measured data under the limit of average detection.
7. The emission levels of other frequencies are very lower than the limit and not show in test report.

Product : Intel® Dual Band Wireless-AC 8260  
 Test Item : Harmonic Radiated Emission Data  
 Test Site : No.3 OATS  
 Test Mode : Mode 2 SISO B: Transmit (802.11g 6Mbps) (2412MHz)

Frequency MHz	Correct Factor dB	Reading Level dBuV	Measurement Level dBuV/m	Margin dB	Limit dBuV/m
<b>Horizontal</b>					
<b>Peak Detector:</b>					
4824.000	3.261	39.840	43.101	-30.899	74.000
7236.000	10.650	39.450	50.100	-23.900	74.000
9648.000	13.337	37.260	50.596	-23.404	74.000
<b>Average Detector:</b>					
--					
<b>Vertical</b>					
<b>Peak Detector:</b>					
4824.000	6.421	41.260	47.681	-26.319	74.000
7236.000	11.495	39.120	50.615	-23.385	74.000
9648.000	13.807	36.840	50.646	-23.354	74.000
<b>Average Detector:</b>					
--					

Note:

1. All Readings below 1GHz are Quasi-Peak, above 1GHz are performed with peak and/or average measurements as necessary.
2. Peak measurements: RBW = 1MHz, VBW = 3 MHz, Sweep: Auto.
3. Average measurements: RBW = 1MHz, VBW = 10 Hz, Sweep: Auto.
4. Measurement Level = Reading Level + Correct Factor.
5. Correct Factor = Antenna factor + Cable loss – Amplifier gain.
6. The average measurement was not performed when the peak measured data under the limit of average detection.
7. The emission levels of other frequencies are very lower than the limit and not show in test report.

Product : Intel® Dual Band Wireless-AC 8260  
 Test Item : Harmonic Radiated Emission Data  
 Test Site : No.3 OATS  
 Test Mode : Mode 2 SISO B: Transmit (802.11g 6Mbps) (2437 MHz)

Frequency MHz	Correct Factor dB	Reading Level dBuV	Measurement Level dBuV/m	Margin dB	Limit dBuV/m
<b>Horizontal</b>					
<b>Peak Detector:</b>					
4874.000	3.038	39.850	42.887	-31.113	74.000
7311.000	11.795	39.420	51.214	-22.786	74.000
9748.000	12.635	37.350	49.985	-24.015	74.000
<b>Average Detector:</b>					
--					
<b>Vertical</b>					
<b>Peak Detector:</b>					
4874.000	5.812	41.560	47.371	-26.629	74.000
7311.000	12.630	39.450	52.079	-21.921	74.000
9748.000	13.126	36.960	50.086	-23.914	74.000
<b>Average Detector:</b>					
--					

Note:

1. All Readings below 1GHz are Quasi-Peak, above 1GHz are performed with peak and/or average measurements as necessary.
2. Peak measurements: RBW = 1MHz, VBW = 3 MHz, Sweep: Auto.
3. Average measurements: RBW = 1MHz, VBW = 10 Hz, Sweep: Auto.
4. Measurement Level = Reading Level + Correct Factor.
5. Correct Factor = Antenna factor + Cable loss – Amplifier gain.
6. The average measurement was not performed when the peak measured data under the limit of average detection.
7. The emission levels of other frequencies are very lower than the limit and not show in test report.



Product : Intel® Dual Band Wireless-AC 8260  
 Test Item : Harmonic Radiated Emission Data  
 Test Site : No.3 OATS  
 Test Mode : Mode 2 SISO B: Transmit (802.11g 6Mbps) (2462 MHz)

Frequency MHz	Correct Factor dB	Reading Level dBuV	Measurement Level dBuV/m	Margin dB	Limit dBuV/m
<b>Horizontal</b>					
<b>Peak Detector:</b>					
4924.000	2.858	39.650	42.507	-31.493	74.000
7386.000	12.127	40.250	52.378	-21.622	74.000
9848.000	12.852	37.350	50.203	-23.797	74.000
<b>Average Detector:</b>					
--					
<b>Vertical</b>					
<b>Peak Detector:</b>					
4924.000	5.521	41.360	46.880	-27.120	74.000
7386.000	13.254	39.680	52.934	-21.066	74.000
9848.000	13.367	37.150	50.517	-23.483	74.000
<b>Average Detector:</b>					
--					

Note:

1. All Readings below 1GHz are Quasi-Peak, above 1GHz are performed with peak and/or average measurements as necessary.
2. Peak measurements: RBW = 1MHz, VBW = 3 MHz, Sweep: Auto.
3. Average measurements: RBW = 1MHz, VBW = 10 Hz, Sweep: Auto.
4. Measurement Level = Reading Level + Correct Factor.
5. Correct Factor = Antenna factor + Cable loss – Amplifier gain.
6. The average measurement was not performed when the peak measured data under the limit of average detection.
7. The emission levels of other frequencies are very lower than the limit and not show in test report.

Product : Intel® Dual Band Wireless-AC 8260  
 Test Item : Harmonic Radiated Emission Data  
 Test Site : No.3 OATS  
 Test Mode : Mode 2 SISO B: Transmit (802.11g 6Mbps) (2467 MHz)

Frequency MHz	Correct Factor dB	Reading Level dBuV	Measurement Level dBuV/m	Margin dB	Limit dBuV/m
<b>Horizontal</b>					
<b>Peak Detector:</b>					
4934.000	2.830	37.540	40.371	-33.629	74.000
7401.000	12.218	36.640	48.858	-25.142	74.000
9868.000	13.043	36.710	49.752	-24.248	74.000
<b>Average Detector:</b>					
--					
<b>Vertical</b>					
<b>Peak Detector:</b>					
4934.000	5.530	37.940	43.471	-30.529	74.000
7401.000	13.345	37.050	50.396	-23.604	74.000
9868.000	13.602	36.910	50.511	-23.489	74.000
<b>Average Detector:</b>					
--					

Note:

1. All Readings below 1GHz are Quasi-Peak, above 1GHz are performed with peak and/or average measurements as necessary.
2. Peak measurements: RBW = 1MHz, VBW = 3 MHz, Sweep: Auto.
3. Average measurements: RBW = 1MHz, VBW = 10 Hz, Sweep: Auto.
4. Measurement Level = Reading Level + Correct Factor.
5. Correct Factor = Antenna factor + Cable loss – Amplifier gain.
6. The average measurement was not performed when the peak measured data under the limit of average detection.
7. The emission levels of other frequencies are very lower than the limit and not show in test report.

Product : Intel® Dual Band Wireless-AC 8260  
Test Item : Harmonic Radiated Emission Data  
Test Site : No.3 OATS  
Test Mode : Mode 2 SISO B: Transmit - 802.11a 6Mbps (5745 MHz)

Frequency	Correct	Reading	Measurement	Margin	Limit
MHz	Factor	Level	Level	dB	dBuV/m
	dB	dBuV	dBuV/m		

**Horizontal**

**Peak Detector:**

11490.000	17.106	35.840	52.947	-21.053	74.000
-----------	--------	--------	--------	---------	--------

**Average**

**Detector:**

--

**Vertical**

**Peak Detector:**

11490.000	18.034	35.680	53.715	-20.285	74.000
-----------	--------	--------	--------	---------	--------

**Average**

**Detector:**

--

Note:

1. All Readings below 1GHz are Quasi-Peak, above 1GHz are performed with peak and/or average measurements as necessary.
2. Peak measurements: RBW = 1MHz, VBW = 3 MHz, Sweep: Auto.
3. Average measurements: RBW = 1MHz, VBW = 10 Hz, Sweep: Auto.
4. Measurement Level = Reading Level + Correct Factor.
5. Correct Factor = Antenna factor + Cable loss –Amplifier gain.
6. The average measurement was not performed when the peak measured data under the limit of average detection.
7. The emission levels of other frequencies are very lower than the limit and not show in test report.

Product : Intel® Dual Band Wireless-AC 8260  
 Test Item : Harmonic Radiated Emission Data  
 Test Site : No.3 OATS  
 Test Mode : Mode 2 SISO B: Transmit - 802.11a 6Mbps (5785 MHz)

Frequency	Correct	Reading	Measurement	Margin	Limit
MHz	Factor	Level	Level	dB	dBuV/m
	dB	dBuV	dBuV/m		

**Horizontal**

**Peak Detector:**

11570.000	16.809	35.690	52.499	-21.501	74.000
-----------	--------	--------	--------	---------	--------

**Average**

**Detector:**

--

**Vertical**

**Peak Detector:**

11570.000	17.698	36.240	53.938	-20.062	74.000
-----------	--------	--------	--------	---------	--------

**Average**

**Detector:**

--

Note:

1. All Readings below 1GHz are Quasi-Peak, above 1GHz are performed with peak and/or average measurements as necessary.
2. Peak measurements: RBW = 1MHz, VBW = 3 MHz, Sweep: Auto.
3. Average measurements: RBW = 1MHz, VBW = 10 Hz, Sweep: Auto.
4. Measurement Level = Reading Level + Correct Factor.
5. Correct Factor = Antenna factor + Cable loss –Amplifier gain.
6. The average measurement was not performed when the peak measured data under the limit of average detection.
7. The emission levels of other frequencies are very lower than the limit and not show in test report.

Product : Intel® Dual Band Wireless-AC 8260  
Test Item : Harmonic Radiated Emission Data  
Test Site : No.3 OATS  
Test Mode : Mode 2 SISO B: Transmit - 802.11a 6Mbps (5825 MHz)

Frequency MHz	Correct Factor dB	Reading Level dBuV	Measurement Level dBuV/m	Margin dB	Limit dBuV/m
<b>Horizontal</b>					
<b>Peak Detector:</b>					
11650.000	16.158	35.770	51.928	-22.072	74.000
<b>Average Detector:</b>					
--					
<b>Vertical</b>					
<b>Peak Detector:</b>					
11650.000	17.274	35.580	52.855	-21.145	74.000
<b>Average Detector:</b>					
--					

Note:

1. All Readings below 1GHz are Quasi-Peak, above 1GHz are performed with peak and/or average measurements as necessary.
2. Peak measurements: RBW = 1MHz, VBW = 3 MHz, Sweep: Auto.
3. Average measurements: RBW = 1MHz, VBW = 10 Hz, Sweep: Auto.
4. Measurement Level = Reading Level + Correct Factor.
5. Correct Factor = Antenna factor + Cable loss –Amplifier gain.
6. The average measurement was not performed when the peak measured data under the limit of average detection.
7. The emission levels of other frequencies are very lower than the limit and not show in test report.

Product : Intel® Dual Band Wireless-AC 8260  
 Test Item : Harmonic Radiated Emission Data  
 Test Site : No.3 OATS  
 Test Mode : Mode 2 SISO B: Transmit - 802.11n-20BW\_7.2Mbps(2.4G Band) (2412MHz)

Frequency MHz	Correct Factor dB	Reading Level dBuV	Measurement Level dBuV/m	Margin dB	Limit dBuV/m
<b>Horizontal</b>					
<b>Peak Detector:</b>					
4824.000	3.261	38.620	41.881	-32.119	74.000
7236.000	10.650	39.810	50.460	-23.540	74.000
9648.000	13.337	37.540	50.876	-23.124	74.000
<b>Average Detector:</b>					
--					
<b>Vertical</b>					
<b>Peak Detector:</b>					
4824.000	6.421	40.420	46.841	-27.159	74.000
7236.000	11.495	38.450	49.945	-24.055	74.000
9648.000	13.807	37.240	51.046	-22.954	74.000
<b>Average Detector:</b>					
--					

Note:

1. All Readings below 1GHz are Quasi-Peak, above 1GHz are performed with peak and/or average measurements as necessary.
2. Peak measurements: RBW = 1MHz, VBW = 3 MHz, Sweep: Auto.
3. Average measurements: RBW = 1MHz, VBW = 10 Hz, Sweep: Auto.
4. Measurement Level = Reading Level + Correct Factor.
5. Correct Factor = Antenna factor + Cable loss – Amplifier gain.
6. The average measurement was not performed when the peak measured data under the limit of average detection.
7. The emission levels of other frequencies are very lower than the limit and not show in test report.

Product : Intel® Dual Band Wireless-AC 8260  
 Test Item : Harmonic Radiated Emission Data  
 Test Site : No.3 OATS  
 Test Mode : Mode 2 SISO B: Transmit - 802.11n-20BW\_7.2Mbps(2.4G Band) (2437 MHz)

Frequency MHz	Correct Factor dB	Reading Level dBuV	Measurement Level dBuV/m	Margin dB	Limit dBuV/m
<b>Horizontal</b>					
<b>Peak Detector:</b>					
4874.000	3.038	38.560	41.597	-32.403	74.000
7311.000	11.795	39.640	51.434	-22.566	74.000
9748.000	12.635	36.850	49.485	-24.515	74.000
<b>Average Detector:</b>					
--					
<b>Vertical</b>					
<b>Peak Detector:</b>					
4874.000	5.812	40.950	46.761	-27.239	74.000
7311.000	12.630	38.450	51.079	-22.921	74.000
9748.000	13.126	36.680	49.806	-24.194	74.000
<b>Average Detector:</b>					
--					

Note:

1. All Readings below 1GHz are Quasi-Peak, above 1GHz are performed with peak and/or average measurements as necessary.
2. Peak measurements: RBW = 1MHz, VBW = 3 MHz, Sweep: Auto.
3. Average measurements: RBW = 1MHz, VBW = 10 Hz, Sweep: Auto.
4. Measurement Level = Reading Level + Correct Factor.
5. Correct Factor = Antenna factor + Cable loss –Amplifier gain.
6. The average measurement was not performed when the peak measured data under the limit of average detection.
7. The emission levels of other frequencies are very lower than the limit and not show in test report.

Product : Intel® Dual Band Wireless-AC 8260  
 Test Item : Harmonic Radiated Emission Data  
 Test Site : No.3 OATS  
 Test Mode : Mode 2 SISO B: Transmit - 802.11n-20BW\_7.2Mbps(2.4G Band) (2462 MHz)

Frequency MHz	Correct Factor dB	Reading Level dBuV	Measurement Level dBuV/m	Margin dB	Limit dBuV/m
<b>Horizontal</b>					
<b>Peak Detector:</b>					
4924.000	2.858	38.650	41.507	-32.493	74.000
7386.000	12.127	39.670	51.798	-22.202	74.000
9848.000	12.852	37.840	50.693	-23.307	74.000
<b>Average Detector:</b>					
--					
<b>Vertical</b>					
<b>Peak Detector:</b>					
4924.000	5.521	40.750	46.270	-27.730	74.000
7386.000	13.254	38.640	51.894	-22.106	74.000
9848.000	13.367	36.420	49.787	-24.213	74.000
<b>Average Detector:</b>					
--					

Note:

1. All Readings below 1GHz are Quasi-Peak, above 1GHz are performed with peak and/or average measurements as necessary.
2. Peak measurements: RBW = 1MHz, VBW = 3 MHz, Sweep: Auto.
3. Average measurements: RBW = 1MHz, VBW = 10 Hz, Sweep: Auto.
4. Measurement Level = Reading Level + Correct Factor.
5. Correct Factor = Antenna factor + Cable loss – Amplifier gain.
6. The average measurement was not performed when the peak measured data under the limit of average detection.
7. The emission levels of other frequencies are very lower than the limit and not show in test report.



Product : Intel® Dual Band Wireless-AC 8260  
 Test Item : Harmonic Radiated Emission Data  
 Test Site : No.3 OATS  
 Test Mode : Mode 2 SISO B: Transmit - 802.11n-20BW\_7.2Mbps(2.4G Band) (2467 MHz)

Frequency MHz	Correct Factor dB	Reading Level dBuV	Measurement Level dBuV/m	Margin dB	Limit dBuV/m
<b>Horizontal</b>					
<b>Peak Detector:</b>					
4934.000	2.830	37.510	40.341	-33.659	74.000
7401.000	12.218	36.940	49.158	-24.842	74.000
9868.000	13.043	36.840	49.882	-24.118	74.000
<b>Average Detector:</b>					
--					
<b>Vertical</b>					
<b>Peak Detector:</b>					
4934.000	5.530	37.520	43.051	-30.949	74.000
7401.000	13.345	36.670	50.016	-23.984	74.000
9868.000	13.602	36.620	50.221	-23.779	74.000
<b>Average Detector:</b>					
--					

Note:

1. All Readings below 1GHz are Quasi-Peak, above 1GHz are performed with peak and/or average measurements as necessary.
2. Peak measurements: RBW = 1MHz, VBW = 3 MHz, Sweep: Auto.
3. Average measurements: RBW = 1MHz, VBW = 10 Hz, Sweep: Auto.
4. Measurement Level = Reading Level + Correct Factor.
5. Correct Factor = Antenna factor + Cable loss – Amplifier gain.
6. The average measurement was not performed when the peak measured data under the limit of average detection.
7. The emission levels of other frequencies are very lower than the limit and not show in test report.

Product : Intel® Dual Band Wireless-AC 8260  
 Test Item : Harmonic Radiated Emission Data  
 Test Site : No.3 OATS  
 Test Mode : Mode 2 SISO B: Transmit - 802.11n-40BW\_15Mbps(2.4G Band) (2422MHz)

Frequency MHz	Correct Factor dB	Reading Level dBuV	Measurement Level dBuV/m	Margin dB	Limit dBuV/m
<b>Horizontal</b>					
<b>Peak Detector:</b>					
4844.000	3.171	38.640	41.811	-32.189	74.000
7266.000	11.162	37.260	48.422	-25.578	74.000
9688.000	12.964	36.730	49.695	-24.305	74.000
<b>Average Detector:</b>					
--					
<b>Vertical</b>					
<b>Peak Detector:</b>					
4844.000	6.178	39.050	45.228	-28.772	74.000
7266.000	11.982	36.820	48.802	-25.198	74.000
9688.000	13.507	36.840	50.348	-23.652	74.000
<b>Average Detector:</b>					
--					

Note:

1. All Readings below 1GHz are Quasi-Peak, above 1GHz are performed with peak and/or average measurements as necessary.
2. Peak measurements: RBW = 1MHz, VBW = 3 MHz, Sweep: Auto.
3. Average measurements: RBW = 1MHz, VBW = 10 Hz, Sweep: Auto.
4. Measurement Level = Reading Level + Correct Factor.
5. Correct Factor = Antenna factor + Cable loss –Amplifier gain.
6. The average measurement was not performed when the peak measured data under the limit of average detection.
7. The emission levels of other frequencies are very lower than the limit and not show in test report.

Product : Intel® Dual Band Wireless-AC 8260  
 Test Item : Harmonic Radiated Emission Data  
 Test Site : No.3 OATS  
 Test Mode : Mode 2 SISO B: Transmit - 802.11n-40BW\_15Mbps(2.4G Band) (2437 MHz)

Frequency MHz	Correct Factor dB	Reading Level dBuV	Measurement Level dBuV/m	Margin dB	Limit dBuV/m
<b>Horizontal</b>					
<b>Peak Detector:</b>					
4874.000	3.038	38.540	41.577	-32.423	74.000
7311.000	11.795	37.290	49.084	-24.916	74.000
9748.000	12.635	36.840	49.475	-24.525	74.000
<b>Average Detector:</b>					
--					
<b>Vertical</b>					
<b>Peak Detector:</b>					
4874.000	5.812	38.950	44.761	-29.239	74.000
7311.000	12.630	36.810	49.439	-24.561	74.000
9748.000	13.126	36.450	49.576	-24.424	74.000
<b>Average Detector:</b>					
--					

Note:

1. All Readings below 1GHz are Quasi-Peak, above 1GHz are performed with peak and/or average measurements as necessary.
2. Peak measurements: RBW = 1MHz, VBW = 3 MHz, Sweep: Auto.
3. Average measurements: RBW = 1MHz, VBW = 10 Hz, Sweep: Auto.
4. Measurement Level = Reading Level + Correct Factor.
5. Correct Factor = Antenna factor + Cable loss – Amplifier gain.
6. The average measurement was not performed when the peak measured data under the limit of average detection.
7. The emission levels of other frequencies are very lower than the limit and not show in test report.

Product : Intel® Dual Band Wireless-AC 8260  
 Test Item : Harmonic Radiated Emission Data  
 Test Site : No.3 OATS  
 Test Mode : Mode 2 SISO B: Transmit - 802.11n-40BW\_15Mbps(2.4G Band) (2452 MHz)

Frequency MHz	Correct Factor dB	Reading Level dBuV	Measurement Level dBuV/m	Margin dB	Limit dBuV/m
<b>Horizontal</b>					
<b>Peak Detector:</b>					
4904.000	2.914	39.040	41.955	-32.045	74.000
7356.000	11.995	37.680	49.674	-24.326	74.000
9808.000	12.475	37.240	49.715	-24.285	74.000
<b>Average Detector:</b>					
--					
<b>Vertical</b>					
<b>Peak Detector:</b>					
4904.000	5.530	40.840	46.371	-27.629	74.000
7356.000	13.005	38.670	51.674	-22.326	74.000
9808.000	12.901	36.460	49.361	-24.639	74.000
<b>Average Detector:</b>					
--					

Note:

1. All Readings below 1GHz are Quasi-Peak, above 1GHz are performed with peak and/or average measurements as necessary.
2. Peak measurements: RBW = 1MHz, VBW = 3 MHz, Sweep: Auto.
3. Average measurements: RBW = 1MHz, VBW = 10 Hz, Sweep: Auto.
4. Measurement Level = Reading Level + Correct Factor.
5. Correct Factor = Antenna factor + Cable loss – Amplifier gain.
6. The average measurement was not performed when the peak measured data under the limit of average detection.
7. The emission levels of other frequencies are very lower than the limit and not show in test report.

Product : Intel® Dual Band Wireless-AC 8260  
 Test Item : Harmonic Radiated Emission Data  
 Test Site : No.3 OATS  
 Test Mode : **Mode 2 SISO B: Transmit - 802.11n-40BW\_15Mbps(2.4G Band) (2457 MHz)**

Frequency MHz	Correct Factor dB	Reading Level dBuV	Measurement Level dBuV/m	Margin dB	Limit dBuV/m
<b>Horizontal</b>					
<b>Peak Detector:</b>					
4914.000	2.883	37.520	40.403	-33.597	74.000
7371.000	12.062	36.480	48.542	-25.458	74.000
9828.000	12.664	36.840	49.504	-24.496	74.000
<b>Average Detector:</b>					
--					
<b>Vertical</b>					
<b>Peak Detector:</b>					
4914.000	5.508	37.250	42.758	-31.242	74.000
7371.000	13.130	36.480	49.610	-24.390	74.000
9828.000	13.135	36.420	49.555	-24.445	74.000
<b>Average Detector:</b>					
--					

Note:

1. All Readings below 1GHz are Quasi-Peak, above 1GHz are performed with peak and/or average measurements as necessary.
2. Peak measurements: RBW = 1MHz, VBW = 3 MHz, Sweep: Auto.
3. Average measurements: RBW = 1MHz, VBW = 10 Hz, Sweep: Auto.
4. Measurement Level = Reading Level + Correct Factor.
5. Correct Factor = Antenna factor + Cable loss –Amplifier gain.
6. The average measurement was not performed when the peak measured data under the limit of average detection.
7. The emission levels of other frequencies are very lower than the limit and not show in test report.

Product : Intel® Dual Band Wireless-AC 8260  
Test Item : Harmonic Radiated Emission Data  
Test Site : No.3 OATS  
Test Mode : Mode 2 SISO B: Transmit - 802.11n-20BW\_7.2Mbps(5G Band) (5745MHz)

Frequency MHz	Correct Factor dB	Reading Level dBuV	Measurement Level dBuV/m	Margin dB	Limit dBuV/m
<b>Horizontal</b>					
<b>Peak Detector:</b>					
11490.000	17.106	35.270	52.377	-21.623	74.000
<b>Average Detector:</b>					
--					
<b>Vertical</b>					
<b>Peak Detector:</b>					
11490.000	18.034	35.420	53.455	-20.545	74.000
<b>Average Detector:</b>					
--					

Note:

1. All Readings below 1GHz are Quasi-Peak, above 1GHz are performed with peak and/or average measurements as necessary.
2. Peak measurements: RBW = 1MHz, VBW = 3 MHz, Sweep: Auto.
3. Average measurements: RBW = 1MHz, VBW = 10 Hz, Sweep: Auto.
4. Measurement Level = Reading Level + Correct Factor.
5. Correct Factor = Antenna factor + Cable loss –Amplifier gain.
6. The average measurement was not performed when the peak measured data under the limit of average detection.
7. The emission levels of other frequencies are very lower than the limit and not show in test report.

Product : Intel® Dual Band Wireless-AC 8260  
Test Item : Harmonic Radiated Emission Data  
Test Site : No.3 OATS  
Test Mode : Mode 2 SISO B: Transmit - 802.11n-20BW\_7.2Mbps(5G Band) (5785 MHz)

Frequency MHz	Correct Factor dB	Reading Level dBuV	Measurement Level dBuV/m	Margin dB	Limit dBuV/m
<b>Horizontal</b>					
<b>Peak Detector:</b>					
11570.000	16.809	35.620	52.429	-21.571	74.000
<b>Average Detector:</b>					
--					
<b>Vertical</b>					
<b>Peak Detector:</b>					
11570.000	17.698	35.810	53.508	-20.492	74.000
<b>Average Detector:</b>					
--					

Note:

1. All Readings below 1GHz are Quasi-Peak, above 1GHz are performed with peak and/or average measurements as necessary.
2. Peak measurements: RBW = 1MHz, VBW = 3 MHz, Sweep: Auto.
3. Average measurements: RBW = 1MHz, VBW = 10 Hz, Sweep: Auto.
4. Measurement Level = Reading Level + Correct Factor.
5. Correct Factor = Antenna factor + Cable loss –Amplifier gain.
6. The average measurement was not performed when the peak measured data under the limit of average detection.
7. The emission levels of other frequencies are very lower than the limit and not show in test report.

Product : Intel® Dual Band Wireless-AC 8260  
 Test Item : Harmonic Radiated Emission Data  
 Test Site : No.3 OATS  
 Test Mode : Mode 2 SISO B: Transmit - 802.11n-20BW\_7.2Mbps(5G Band) (5825 MHz)

Frequency MHz	Correct Factor dB	Reading Level dBuV	Measurement Level dBuV/m	Margin dB	Limit dBuV/m
<b>Horizontal</b>					
<b>Peak Detector:</b>					
11650.000	16.158	35.620	51.778	-22.222	74.000
<b>Average Detector:</b>					
--					
<b>Vertical</b>					
<b>Peak Detector:</b>					
11650.000	17.274	35.720	52.995	-21.005	74.000
<b>Average Detector:</b>					
--					

Note:

1. All Readings below 1GHz are Quasi-Peak, above 1GHz are performed with peak and/or average measurements as necessary.
2. Peak measurements: RBW = 1MHz, VBW = 3 MHz, Sweep: Auto.
3. Average measurements: RBW = 1MHz, VBW = 10 Hz, Sweep: Auto.
4. Measurement Level = Reading Level + Correct Factor.
5. Correct Factor = Antenna factor + Cable loss – Amplifier gain.
6. The average measurement was not performed when the peak measured data under the limit of average detection.
7. The emission levels of other frequencies are very lower than the limit and not show in test report.



Product : Intel® Dual Band Wireless-AC 8260  
 Test Item : Harmonic Radiated Emission Data  
 Test Site : No.3 OATS  
 Test Mode : Mode 2 SISO B: Transmit - 802.11n-40BW\_15Mbps(5G Band) (5755MHz)

Frequency MHz	Correct Factor dB	Reading Level dBuV	Measurement Level dBuV/m	Margin dB	Limit dBuV/m
<b>Horizontal</b>					
<b>Peak Detector:</b>					
11510.000	17.124	35.750	52.874	-21.126	74.000
<b>Average Detector:</b>					
--					
<b>Vertical</b>					
<b>Peak Detector:</b>					
11510.000	18.081	35.720	53.801	-20.199	74.000
<b>Average Detector:</b>					
--					

Note:

1. All Readings below 1GHz are Quasi-Peak, above 1GHz are performed with peak and/or average measurements as necessary.
2. Peak measurements: RBW = 1MHz, VBW = 3 MHz, Sweep: Auto.
3. Average measurements: RBW = 1MHz, VBW = 10 Hz, Sweep: Auto.
4. Measurement Level = Reading Level + Correct Factor.
5. Correct Factor = Antenna factor + Cable loss – Amplifier gain.
6. The average measurement was not performed when the peak measured data under the limit of average detection.
7. The emission levels of other frequencies are very lower than the limit and not show in test report.

Product : Intel® Dual Band Wireless-AC 8260  
Test Item : Harmonic Radiated Emission Data  
Test Site : No.3 OATS  
Test Mode : Mode 2 SISO B: Transmit - 802.11n-40BW\_15Mbps(5G Band) (5795 MHz)

Frequency MHz	Correct Factor dB	Reading Level dBuV	Measurement Level dBuV/m	Margin dB	Limit dBuV/m
<b>Horizontal</b>					
<b>Peak Detector:</b>					
11590.000	16.701	35.940	52.640	-21.360	74.000
<b>Average Detector:</b>					
--					
<b>Vertical</b>					
<b>Peak Detector:</b>					
11590.000	17.567	35.640	53.206	-20.794	74.000
<b>Average Detector:</b>					
--					

Note:

1. All Readings below 1GHz are Quasi-Peak, above 1GHz are performed with peak and/or average measurements as necessary.
2. Peak measurements: RBW = 1MHz, VBW = 3 MHz, Sweep: Auto.
3. Average measurements: RBW = 1MHz, VBW = 10 Hz, Sweep: Auto.
4. Measurement Level = Reading Level + Correct Factor.
5. Correct Factor = Antenna factor + Cable loss –Amplifier gain.
6. The average measurement was not performed when the peak measured data under the limit of average detection.
7. The emission levels of other frequencies are very lower than the limit and not show in test report.

Product : Intel® Dual Band Wireless-AC 8260  
Test Item : Harmonic Radiated Emission Data  
Test Site : No.3 OATS  
Test Mode : Mode 2 SISO B: Transmit - 802.11ac-80BW\_32.5Mbps(5G Band) (5775 MHz)

Frequency MHz	Correct Factor dB	Reading Level dBuV	Measurement Level dBuV/m	Margin dB	Limit dBuV/m
<b>Horizontal</b>					
<b>Peak Detector:</b>					
11550.000	17.018	36.270	53.289	-20.711	74.000
<b>Average Detector:</b>					
--					
<b>Vertical</b>					
<b>Peak Detector:</b>					
11550.000	17.952	35.480	53.433	-20.567	74.000
<b>Average Detector:</b>					
--					

Note:

1. All Readings below 1GHz are Quasi-Peak, above 1GHz are performed with peak and/or average measurements as necessary.
2. Peak measurements: RBW = 1MHz, VBW = 3 MHz, Sweep: Auto.
3. Average measurements: RBW = 1MHz, VBW = 10 Hz, Sweep: Auto.
4. Measurement Level = Reading Level + Correct Factor.
5. Correct Factor = Antenna factor + Cable loss –Amplifier gain.
6. The average measurement was not performed when the peak measured data under the limit of average detection.
7. The emission levels of other frequencies are very lower than the limit and not show in test report.

Product : Intel® Dual Band Wireless-AC 8260  
 Test Item : Harmonic Radiated Emission Data  
 Test Site : No.3 OATS  
 Test Mode : Mode 3 MIMO: Transmit - 802.11n-20BW\_14.4Mbps(2.4G Band) (2412MHz)

Frequency MHz	Correct Factor dB	Reading Level dBuV	Measurement Level dBuV/m	Margin dB	Limit dBuV/m
<b>Horizontal</b>					
<b>Peak Detector:</b>					
4824.000	3.261	38.420	41.681	-32.319	74.000
7236.000	10.650	39.650	50.300	-23.700	74.000
9648.000	13.337	37.350	50.686	-23.314	74.000
<b>Average Detector:</b>					
--					
<b>Vertical</b>					
<b>Peak Detector:</b>					
4824.000	6.421	40.150	46.571	-27.429	74.000
7236.000	11.495	38.250	49.745	-24.255	74.000
9648.000	13.807	37.110	50.916	-23.084	74.000
<b>Average Detector:</b>					
--					

Note:

1. All Readings below 1GHz are Quasi-Peak, above 1GHz are performed with peak and/or average measurements as necessary.
2. Peak measurements: RBW = 1MHz, VBW = 3 MHz, Sweep: Auto.
3. Average measurements: RBW = 1MHz, VBW = 10 Hz, Sweep: Auto.
4. Measurement Level = Reading Level + Correct Factor.
5. Correct Factor = Antenna factor + Cable loss – Amplifier gain.
6. The average measurement was not performed when the peak measured data under the limit of average detection.
7. The emission levels of other frequencies are very lower than the limit and not show in test report.

Product : Intel® Dual Band Wireless-AC 8260  
 Test Item : Harmonic Radiated Emission Data  
 Test Site : No.3 OATS  
 Test Mode : Mode 3 MIMO: Transmit - 802.11n-20BW\_14.4Mbps(2.4G Band) (2437 MHz)

Frequency MHz	Correct Factor dB	Reading Level dBuV	Measurement Level dBuV/m	Margin dB	Limit dBuV/m
<b>Horizontal</b>					
<b>Peak Detector:</b>					
4874.000	3.038	38.410	41.447	-32.553	74.000
7311.000	11.795	39.340	51.134	-22.866	74.000
9748.000	12.635	36.690	49.325	-24.675	74.000
<b>Average Detector:</b>					
--					
<b>Vertical</b>					
<b>Peak Detector:</b>					
4874.000	5.812	40.790	46.601	-27.399	74.000
7311.000	12.630	38.270	50.899	-23.101	74.000
9748.000	13.126	36.520	49.646	-24.354	74.000
<b>Average Detector:</b>					
--					

Note:

1. All Readings below 1GHz are Quasi-Peak, above 1GHz are performed with peak and/or average measurements as necessary.
2. Peak measurements: RBW = 1MHz, VBW = 3 MHz, Sweep: Auto.
3. Average measurements: RBW = 1MHz, VBW = 10 Hz, Sweep: Auto.
4. Measurement Level = Reading Level + Correct Factor.
5. Correct Factor = Antenna factor + Cable loss – Amplifier gain.
6. The average measurement was not performed when the peak measured data under the limit of average detection.
7. The emission levels of other frequencies are very lower than the limit and not show in test report.

Product : Intel® Dual Band Wireless-AC 8260  
 Test Item : Harmonic Radiated Emission Data  
 Test Site : No.3 OATS  
 Test Mode : Mode 3 MIMO: Transmit - 802.11n-20BW\_14.4Mbps(2.4G Band) (2462 MHz)

Frequency MHz	Correct Factor dB	Reading Level dBuV	Measurement Level dBuV/m	Margin dB	Limit dBuV/m
<b>Horizontal</b>					
<b>Peak Detector:</b>					
4924.000	2.858	38.460	41.317	-32.683	74.000
7386.000	12.127	39.540	51.668	-22.332	74.000
9848.000	12.852	37.590	50.443	-23.557	74.000
<b>Average Detector:</b>					
--					
<b>Vertical</b>					
<b>Peak Detector:</b>					
4924.000	5.521	40.610	46.130	-27.870	74.000
7386.000	13.254	38.390	51.644	-22.356	74.000
9848.000	13.367	36.410	49.777	-24.223	74.000
<b>Average Detector:</b>					
--					

Note:

1. All Readings below 1GHz are Quasi-Peak, above 1GHz are performed with peak and/or average measurements as necessary.
2. Peak measurements: RBW = 1MHz, VBW = 3 MHz, Sweep: Auto.
3. Average measurements: RBW = 1MHz, VBW = 10 Hz, Sweep: Auto.
4. Measurement Level = Reading Level + Correct Factor.
5. Correct Factor = Antenna factor + Cable loss – Amplifier gain.
6. The average measurement was not performed when the peak measured data under the limit of average detection.
7. The emission levels of other frequencies are very lower than the limit and not show in test report.

Product : Intel® Dual Band Wireless-AC 8260  
 Test Item : Harmonic Radiated Emission Data  
 Test Site : No.3 OATS  
 Test Mode : Mode 3 MIMO: Transmit - 802.11n-20BW\_14.4Mbps(2.4G Band) (2467 MHz)

Frequency MHz	Correct Factor dB	Reading Level dBuV	Measurement Level dBuV/m	Margin dB	Limit dBuV/m
<b>Horizontal</b>					
<b>Peak Detector:</b>					
4934.000	2.830	37.580	40.411	-33.589	74.000
7401.000	12.218	36.760	48.978	-25.022	74.000
9868.000	13.043	36.480	49.522	-24.478	74.000
<b>Average Detector:</b>					
--					
<b>Vertical</b>					
<b>Peak Detector:</b>					
4934.000	5.530	37.420	42.951	-31.049	74.000
7401.000	13.345	36.510	49.856	-24.144	74.000
9868.000	13.602	36.380	49.981	-24.019	74.000
<b>Average Detector:</b>					
--					

Note:

1. All Readings below 1GHz are Quasi-Peak, above 1GHz are performed with peak and/or average measurements as necessary.
2. Peak measurements: RBW = 1MHz, VBW = 3 MHz, Sweep: Auto.
3. Average measurements: RBW = 1MHz, VBW = 10 Hz, Sweep: Auto.
4. Measurement Level = Reading Level + Correct Factor.
5. Correct Factor = Antenna factor + Cable loss – Amplifier gain.
6. The average measurement was not performed when the peak measured data under the limit of average detection.
7. The emission levels of other frequencies are very lower than the limit and not show in test report.

Product : Intel® Dual Band Wireless-AC 8260  
 Test Item : Harmonic Radiated Emission Data  
 Test Site : No.3 OATS  
 Test Mode : Mode 3 MIMO: Transmit - 802.11n-40BW\_30Mbps(2.4G Band) (2422MHz)

Frequency MHz	Correct Factor dB	Reading Level dBuV	Measurement Level dBuV/m	Margin dB	Limit dBuV/m
<b>Horizontal</b>					
<b>Peak Detector:</b>					
4844.000	3.171	38.510	41.681	-32.319	74.000
7266.000	11.162	37.030	48.192	-25.808	74.000
9688.000	12.964	36.510	49.475	-24.525	74.000
<b>Average Detector:</b>					
--					
<b>Vertical</b>					
<b>Peak Detector:</b>					
4844.000	6.178	39.010	45.188	-28.812	74.000
7266.000	11.982	36.710	48.692	-25.308	74.000
9688.000	13.507	36.680	50.188	-23.812	74.000
<b>Average Detector:</b>					
--					

Note:

1. All Readings below 1GHz are Quasi-Peak, above 1GHz are performed with peak and/or average measurements as necessary.
2. Peak measurements: RBW = 1MHz, VBW = 3 MHz, Sweep: Auto.
3. Average measurements: RBW = 1MHz, VBW = 10 Hz, Sweep: Auto.
4. Measurement Level = Reading Level + Correct Factor.
5. Correct Factor = Antenna factor + Cable loss – Amplifier gain.
6. The average measurement was not performed when the peak measured data under the limit of average detection.
7. The emission levels of other frequencies are very lower than the limit and not show in test report.



Product : Intel® Dual Band Wireless-AC 8260  
 Test Item : Harmonic Radiated Emission Data  
 Test Site : No.3 OATS  
 Test Mode : Mode 3 MIMO: Transmit - 802.11n-40BW\_30Mbps(2.4G Band) (2437 MHz)

Frequency MHz	Correct Factor dB	Reading Level dBuV	Measurement Level dBuV/m	Margin dB	Limit dBuV/m
<b>Horizontal</b>					
<b>Peak Detector:</b>					
4874.000	3.038	38.350	41.387	-32.613	74.000
7311.000	11.795	37.120	48.914	-25.086	74.000
9748.000	12.635	36.640	49.275	-24.725	74.000
<b>Average Detector:</b>					
--					
<b>Vertical</b>					
<b>Peak Detector:</b>					
4874.000	5.812	38.690	44.501	-29.499	74.000
7311.000	12.630	36.650	49.279	-24.721	74.000
9748.000	13.126	36.310	49.436	-24.564	74.000
<b>Average Detector:</b>					
--					

Note:

1. All Readings below 1GHz are Quasi-Peak, above 1GHz are performed with peak and/or average measurements as necessary.
2. Peak measurements: RBW = 1MHz, VBW = 3 MHz, Sweep: Auto.
3. Average measurements: RBW = 1MHz, VBW = 10 Hz, Sweep: Auto.
4. Measurement Level = Reading Level + Correct Factor.
5. Correct Factor = Antenna factor + Cable loss – Amplifier gain.
6. The average measurement was not performed when the peak measured data under the limit of average detection.
7. The emission levels of other frequencies are very lower than the limit and not show in test report.

Product : Intel® Dual Band Wireless-AC 8260  
 Test Item : Harmonic Radiated Emission Data  
 Test Site : No.3 OATS  
 Test Mode : Mode 3 MIMO: Transmit - 802.11n-40BW\_30Mbps(2.4G Band) (2452 MHz)

Frequency MHz	Correct Factor dB	Reading Level dBuV	Measurement Level dBuV/m	Margin dB	Limit dBuV/m
<b>Horizontal</b>					
<b>Peak Detector:</b>					
4904.000	2.914	38.850	41.765	-32.235	74.000
7356.000	11.995	37.610	49.604	-24.396	74.000
9808.000	12.475	37.060	49.535	-24.465	74.000
<b>Average Detector:</b>					
--					
<b>Vertical</b>					
<b>Peak Detector:</b>					
4904.000	5.530	40.560	46.091	-27.909	74.000
7356.000	13.005	38.450	51.454	-22.546	74.000
9808.000	12.901	36.270	49.171	-24.829	74.000
<b>Average Detector:</b>					
--					

Note:

1. All Readings below 1GHz are Quasi-Peak, above 1GHz are performed with peak and/or average measurements as necessary.
2. Peak measurements: RBW = 1MHz, VBW = 3 MHz, Sweep: Auto.
3. Average measurements: RBW = 1MHz, VBW = 10 Hz, Sweep: Auto.
4. Measurement Level = Reading Level + Correct Factor.
5. Correct Factor = Antenna factor + Cable loss – Amplifier gain.
6. The average measurement was not performed when the peak measured data under the limit of average detection.
7. The emission levels of other frequencies are very lower than the limit and not show in test report.

Product : Intel® Dual Band Wireless-AC 8260  
 Test Item : Harmonic Radiated Emission Data  
 Test Site : No.3 OATS  
 Test Mode : **Mode 3** MIMO: Transmit - 802.11n-40BW\_30Mbps(2.4G Band) (2457 MHz)

Frequency MHz	Correct Factor dB	Reading Level dBuV	Measurement Level dBuV/m	Margin dB	Limit dBuV/m
<b>Horizontal</b>					
<b>Peak Detector:</b>					
4914.000	2.883	37.410	40.293	-33.707	74.000
7371.000	12.062	36.580	48.642	-25.358	74.000
9828.000	12.664	36.790	49.454	-24.546	74.000
<b>Average Detector:</b>					
--					
<b>Vertical</b>					
<b>Peak Detector:</b>					
4914.000	5.508	37.670	43.178	-30.822	74.000
7371.000	13.130	36.590	49.720	-24.280	74.000
9828.000	13.135	36.480	49.615	-24.385	74.000
<b>Average Detector:</b>					
--					

Note:

1. All Readings below 1GHz are Quasi-Peak, above 1GHz are performed with peak and/or average measurements as necessary.
2. Peak measurements: RBW = 1MHz, VBW = 3 MHz, Sweep: Auto.
3. Average measurements: RBW = 1MHz, VBW = 10 Hz, Sweep: Auto.
4. Measurement Level = Reading Level + Correct Factor.
5. Correct Factor = Antenna factor + Cable loss –Amplifier gain.
6. The average measurement was not performed when the peak measured data under the limit of average detection.
7. The emission levels of other frequencies are very lower than the limit and not show in test report.

Product : Intel® Dual Band Wireless-AC 8260  
Test Item : Harmonic Radiated Emission Data  
Test Site : No.3 OATS  
Test Mode : Mode 3 MIMO: Transmit - 802.11n-20BW\_14.4Mbps(5G Band) (5745MHz)

Frequency MHz	Correct Factor dB	Reading Level dBuV	Measurement Level dBuV/m	Margin dB	Limit dBuV/m
<b>Horizontal</b>					
<b>Peak Detector:</b>					
11490.000	17.106	35.180	52.287	-21.713	74.000
<b>Average Detector:</b>					
--					
<b>Vertical</b>					
<b>Peak Detector:</b>					
11490.000	18.034	35.340	53.375	-20.625	74.000
<b>Average Detector:</b>					
--					

Note:

1. All Readings below 1GHz are Quasi-Peak, above 1GHz are performed with peak and/or average measurements as necessary.
2. Peak measurements: RBW = 1MHz, VBW = 3 MHz, Sweep: Auto.
3. Average measurements: RBW = 1MHz, VBW = 10 Hz, Sweep: Auto.
4. Measurement Level = Reading Level + Correct Factor.
5. Correct Factor = Antenna factor + Cable loss –Amplifier gain.
6. The average measurement was not performed when the peak measured data under the limit of average detection.
7. The emission levels of other frequencies are very lower than the limit and not show in test report.

Product : Intel® Dual Band Wireless-AC 8260  
 Test Item : Harmonic Radiated Emission Data  
 Test Site : No.3 OATS  
 Test Mode : Mode 3 MIMO: Transmit - 802.11n-20BW\_14.4Mbps(5G Band) (5785 MHz)

Frequency MHz	Correct Factor dB	Reading Level dBuV	Measurement Level dBuV/m	Margin dB	Limit dBuV/m
<b>Horizontal</b>					
<b>Peak Detector:</b>					
11570.000	16.809	35.480	52.289	-21.711	74.000
<b>Average Detector:</b>					
--					
<b>Vertical</b>					
<b>Peak Detector:</b>					
11570.000	17.698	35.640	53.338	-20.662	74.000
<b>Average Detector:</b>					
--					

Note:

1. All Readings below 1GHz are Quasi-Peak, above 1GHz are performed with peak and/or average measurements as necessary.
2. Peak measurements: RBW = 1MHz, VBW = 3 MHz, Sweep: Auto.
3. Average measurements: RBW = 1MHz, VBW = 10 Hz, Sweep: Auto.
4. Measurement Level = Reading Level + Correct Factor.
5. Correct Factor = Antenna factor + Cable loss – Amplifier gain.
6. The average measurement was not performed when the peak measured data under the limit of average detection.
7. The emission levels of other frequencies are very lower than the limit and not show in test report.

Product : Intel® Dual Band Wireless-AC 8260  
 Test Item : Harmonic Radiated Emission Data  
 Test Site : No.3 OATS  
 Test Mode : Mode 3 MIMO: Transmit - 802.11n-20BW\_14.4Mbps(5G Band) (5825 MHz)

Frequency MHz	Correct Factor dB	Reading Level dBuV	Measurement Level dBuV/m	Margin dB	Limit dBuV/m
<b>Horizontal</b>					
<b>Peak Detector:</b>					
11650.000	16.158	35.450	51.608	-22.392	74.000
<b>Average Detector:</b>					
--					
<b>Vertical</b>					
<b>Peak Detector:</b>					
11650.000	17.274	35.540	52.815	-21.185	74.000
<b>Average Detector:</b>					
--					

Note:

1. All Readings below 1GHz are Quasi-Peak, above 1GHz are performed with peak and/or average measurements as necessary.
2. Peak measurements: RBW = 1MHz, VBW = 3 MHz, Sweep: Auto.
3. Average measurements: RBW = 1MHz, VBW = 10 Hz, Sweep: Auto.
4. Measurement Level = Reading Level + Correct Factor.
5. Correct Factor = Antenna factor + Cable loss – Amplifier gain.
6. The average measurement was not performed when the peak measured data under the limit of average detection.
7. The emission levels of other frequencies are very lower than the limit and not show in test report.

Product : Intel® Dual Band Wireless-AC 8260  
 Test Item : Harmonic Radiated Emission Data  
 Test Site : No.3 OATS  
 Test Mode : Mode 3 MIMO: Transmit - 802.11n-40BW\_30Mbps(5G Band) (5755MHz)

Frequency MHz	Correct Factor dB	Reading Level dBuV	Measurement Level dBuV/m	Margin dB	Limit dBuV/m
<b>Horizontal</b>					
<b>Peak Detector:</b>					
11510.000	17.124	35.580	52.704	-21.296	74.000
<b>Average Detector:</b>					
--					
<b>Vertical</b>					
<b>Peak Detector:</b>					
11510.000	18.081	35.640	53.721	-20.279	74.000
<b>Average Detector:</b>					
--					

Note:

1. All Readings below 1GHz are Quasi-Peak, above 1GHz are performed with peak and/or average measurements as necessary.
2. Peak measurements: RBW = 1MHz, VBW = 3 MHz, Sweep: Auto.
3. Average measurements: RBW = 1MHz, VBW = 10 Hz, Sweep: Auto.
4. Measurement Level = Reading Level + Correct Factor.
5. Correct Factor = Antenna factor + Cable loss –Amplifier gain.
6. The average measurement was not performed when the peak measured data under the limit of average detection.
7. The emission levels of other frequencies are very lower than the limit and not show in test report.

Product : Intel® Dual Band Wireless-AC 8260  
 Test Item : Harmonic Radiated Emission Data  
 Test Site : No.3 OATS  
 Test Mode : Mode 3 MIMO: Transmit - 802.11n-40BW\_30Mbps(5G Band) (5795 MHz)

Frequency MHz	Correct Factor dB	Reading Level dBuV	Measurement Level dBuV/m	Margin dB	Limit dBuV/m
<b>Horizontal</b>					
<b>Peak Detector:</b>					
11590.000	16.701	35.790	52.490	-21.510	74.000
<b>Average Detector:</b>					
--					
<b>Vertical</b>					
<b>Peak Detector:</b>					
11590.000	17.567	35.480	53.046	-20.954	74.000
<b>Average Detector:</b>					
--					

Note:

1. All Readings below 1GHz are Quasi-Peak, above 1GHz are performed with peak and/or average measurements as necessary.
2. Peak measurements: RBW = 1MHz, VBW = 3 MHz, Sweep: Auto.
3. Average measurements: RBW = 1MHz, VBW = 10 Hz, Sweep: Auto.
4. Measurement Level = Reading Level + Correct Factor.
5. Correct Factor = Antenna factor + Cable loss – Amplifier gain.
6. The average measurement was not performed when the peak measured data under the limit of average detection.
7. The emission levels of other frequencies are very lower than the limit and not show in test report.



Product : Intel® Dual Band Wireless-AC 8260  
Test Item : Harmonic Radiated Emission Data  
Test Site : No.3 OATS  
Test Mode : Mode 3 MIMO: Transmit - 802.11ac-80BW\_65Mbps(5G Band) (5775 MHz)

Frequency MHz	Correct Factor dB	Reading Level dBuV	Measurement Level dBuV/m	Margin dB	Limit dBuV/m
<b>Horizontal</b>					
<b>Peak Detector:</b>					
11530.000	17.018	36.120	53.139	-20.861	74.000
<b>Average Detector:</b>					
--					
<b>Vertical</b>					
<b>Peak Detector:</b>					
11530.000	17.952	35.270	53.223	-20.777	74.000
<b>Average Detector:</b>					
--					

Note:

1. All Readings below 1GHz are Quasi-Peak, above 1GHz are performed with peak and/or average measurements as necessary.
2. Peak measurements: RBW = 1MHz, VBW = 3 MHz, Sweep: Auto.
3. Average measurements: RBW = 1MHz, VBW = 10 Hz, Sweep: Auto.
4. Measurement Level = Reading Level + Correct Factor.
5. Correct Factor = Antenna factor + Cable loss –Amplifier gain.
6. The average measurement was not performed when the peak measured data under the limit of average detection.
7. The emission levels of other frequencies are very lower than the limit and not show in test report.

Product : Intel® Dual Band Wireless-AC 8260  
 Test Item : Harmonic Radiated Emission Data  
 Test Site : No.3 OATS  
 Test Mode : Mode 4 Beamforming: Transmit - 802.11n-20BW\_14.4Mbps(2.4G Band) (2412MHz)

Frequency MHz	Correct Factor dB	Reading Level dBuV	Measurement Level dBuV/m	Margin dB	Limit dBuV/m
<b>Horizontal</b>					
<b>Peak Detector:</b>					
4824.000	3.261	38.450	41.711	-32.289	74.000
7236.000	10.650	39.650	50.300	-23.700	74.000
9648.000	13.337	37.440	50.776	-23.224	74.000
<b>Average Detector:</b>					
--					
<b>Vertical</b>					
<b>Peak Detector:</b>					
4824.000	6.421	40.280	46.701	-27.299	74.000
7236.000	11.495	38.270	49.765	-24.235	74.000
9648.000	13.807	37.150	50.956	-23.044	74.000
<b>Average Detector:</b>					
--					

Note:

1. All Readings below 1GHz are Quasi-Peak, above 1GHz are performed with peak and/or average measurements as necessary.
2. Peak measurements: RBW = 1MHz, VBW = 3 MHz, Sweep: Auto.
3. Average measurements: RBW = 1MHz, VBW = 10 Hz, Sweep: Auto.
4. Measurement Level = Reading Level + Correct Factor.
5. Correct Factor = Antenna factor + Cable loss – Amplifier gain.
6. The average measurement was not performed when the peak measured data under the limit of average detection.
7. The emission levels of other frequencies are very lower than the limit and not show in test report.

Product : Intel® Dual Band Wireless-AC 8260  
 Test Item : Harmonic Radiated Emission Data  
 Test Site : No.3 OATS  
 Test Mode : Mode 4 Beamforming: Transmit - 802.11n-20BW\_14.4Mbps(2.4G Band) (2437 MHz)

Frequency MHz	Correct Factor dB	Reading Level dBuV	Measurement Level dBuV/m	Margin dB	Limit dBuV/m
------------------	-------------------------	--------------------------	--------------------------------	--------------	-----------------

**Horizontal**

**Peak Detector:**

4874.000	3.038	38.380	41.417	-32.583	74.000
7311.000	11.795	39.450	51.244	-22.756	74.000
9748.000	12.635	36.670	49.305	-24.695	74.000

**Average  
Detector:**

--

**Vertical**

**Peak Detector:**

4874.000	5.812	40.840	46.651	-27.349	74.000
7311.000	12.630	38.310	50.939	-23.061	74.000
9748.000	13.126	36.410	49.536	-24.464	74.000

**Average  
Detector:**

--

Note:

1. All Readings below 1GHz are Quasi-Peak, above 1GHz are performed with peak and/or average measurements as necessary.
2. Peak measurements: RBW = 1MHz, VBW = 3 MHz, Sweep: Auto.
3. Average measurements: RBW = 1MHz, VBW = 10 Hz, Sweep: Auto.
4. Measurement Level = Reading Level + Correct Factor.
5. Correct Factor = Antenna factor + Cable loss – Amplifier gain.
6. The average measurement was not performed when the peak measured data under the limit of average detection.
7. The emission levels of other frequencies are very lower than the limit and not show in test report.

Product : Intel® Dual Band Wireless-AC 8260  
 Test Item : Harmonic Radiated Emission Data  
 Test Site : No.3 OATS  
 Test Mode : Mode 4 Beamforming: Transmit - 802.11n-20BW\_14.4Mbps(2.4G Band) (2462 MHz)

Frequency MHz	Correct Factor dB	Reading Level dBuV	Measurement Level dBuV/m	Margin dB	Limit dBuV/m
<b>Horizontal</b>					
<b>Peak Detector:</b>					
4924.000	2.858	38.450	41.307	-32.693	74.000
7386.000	12.127	39.550	51.678	-22.322	74.000
9848.000	12.852	37.560	50.413	-23.587	74.000
<b>Average Detector:</b>					
--					
<b>Vertical</b>					
<b>Peak Detector:</b>					
4924.000	5.521	40.560	46.080	-27.920	74.000
7386.000	13.254	38.470	51.724	-22.276	74.000
9848.000	13.367	36.290	49.657	-24.343	74.000
<b>Average Detector:</b>					
--					

Note:

1. All Readings below 1GHz are Quasi-Peak, above 1GHz are performed with peak and/or average measurements as necessary.
2. Peak measurements: RBW = 1MHz, VBW = 3 MHz, Sweep: Auto.
3. Average measurements: RBW = 1MHz, VBW = 10 Hz, Sweep: Auto.
4. Measurement Level = Reading Level + Correct Factor.
5. Correct Factor = Antenna factor + Cable loss – Amplifier gain.
6. The average measurement was not performed when the peak measured data under the limit of average detection.
7. The emission levels of other frequencies are very lower than the limit and not show in test report.

Product : Intel® Dual Band Wireless-AC 8260  
 Test Item : Harmonic Radiated Emission Data  
 Test Site : No.3 OATS  
 Test Mode : Mode 4 Beamforming: Transmit - 802.11n-20BW\_14.4Mbps(2.4G Band) (2467 MHz)

Frequency MHz	Correct Factor dB	Reading Level dBuV	Measurement Level dBuV/m	Margin dB	Limit dBuV/m
<b>Horizontal</b>					
<b>Peak Detector:</b>					
4934.000	2.830	38.070	40.901	-33.099	74.000
7401.000	12.218	37.190	49.408	-24.592	74.000
9868.000	13.043	37.060	50.102	-23.898	74.000
<b>Average Detector:</b>					
--					
<b>Vertical</b>					
<b>Peak Detector:</b>					
4934.000	5.530	37.920	43.451	-30.549	74.000
7401.000	13.345	36.870	50.216	-23.784	74.000
9868.000	13.602	36.920	50.521	-23.479	74.000
<b>Average Detector:</b>					
--					

Note:

1. All Readings below 1GHz are Quasi-Peak, above 1GHz are performed with peak and/or average measurements as necessary.
2. Peak measurements: RBW = 1MHz, VBW = 3 MHz, Sweep: Auto.
3. Average measurements: RBW = 1MHz, VBW = 10 Hz, Sweep: Auto.
4. Measurement Level = Reading Level + Correct Factor.
5. Correct Factor = Antenna factor + Cable loss – Amplifier gain.
6. The average measurement was not performed when the peak measured data under the limit of average detection.
7. The emission levels of other frequencies are very lower than the limit and not show in test report.

Product : Intel® Dual Band Wireless-AC 8260  
Test Item : Harmonic Radiated Emission Data  
Test Site : No.3 OATS  
Test Mode : Mode 4 Beamforming: Transmit - 802.11n-20BW\_14.4Mbps(2.4G Band) (2422MHz)

Frequency MHz	Correct Factor dB	Reading Level dBuV	Measurement Level dBuV/m	Margin dB	Limit dBuV/m
<b>Horizontal</b>					
<b>Peak Detector:</b>					
4844.000	3.171	38.450	41.621	-32.379	74.000
7266.000	11.162	37.120	48.282	-25.718	74.000
9688.000	12.964	36.540	49.505	-24.495	74.000
<b>Average Detector:</b>					
--					
<b>Vertical</b>					
<b>Peak Detector:</b>					
4844.000	6.178	38.850	45.028	-28.972	74.000
7266.000	11.982	36.560	48.542	-25.458	74.000
9688.000	13.507	36.670	50.178	-23.822	74.000
<b>Average Detector:</b>					
--					

Note:

1. All Readings below 1GHz are Quasi-Peak, above 1GHz are performed with peak and/or average measurements as necessary.
2. Peak measurements: RBW = 1MHz, VBW = 3 MHz, Sweep: Auto.
3. Average measurements: RBW = 1MHz, VBW = 10 Hz, Sweep: Auto.
4. Measurement Level = Reading Level + Correct Factor.
5. Correct Factor = Antenna factor + Cable loss – Amplifier gain.
6. The average measurement was not performed when the peak measured data under the limit of average detection.
7. The emission levels of other frequencies are very lower than the limit and not show in test report.

Product : Intel® Dual Band Wireless-AC 8260  
 Test Item : Harmonic Radiated Emission Data  
 Test Site : No.3 OATS  
 Test Mode : Mode 4 Beamforming: Transmit - 802.11n-20BW\_14.4Mbps(2.4G Band) (2437 MHz)

Frequency MHz	Correct Factor dB	Reading Level dBuV	Measurement Level dBuV/m	Margin dB	Limit dBuV/m
<b>Horizontal</b>					
<b>Peak Detector:</b>					
4874.000	3.038	38.340	41.377	-32.623	74.000
7311.000	11.795	37.120	48.914	-25.086	74.000
9748.000	12.635	36.640	49.275	-24.725	74.000
<b>Average Detector:</b>					
--					
<b>Vertical</b>					
<b>Peak Detector:</b>					
4874.000	5.812	38.750	44.561	-29.439	74.000
7311.000	12.630	36.680	49.309	-24.691	74.000
9748.000	13.126	36.240	49.366	-24.634	74.000
<b>Average Detector:</b>					
--					

Note:

1. All Readings below 1GHz are Quasi-Peak, above 1GHz are performed with peak and/or average measurements as necessary.
2. Peak measurements: RBW = 1MHz, VBW = 3 MHz, Sweep: Auto.
3. Average measurements: RBW = 1MHz, VBW = 10 Hz, Sweep: Auto.
4. Measurement Level = Reading Level + Correct Factor.
5. Correct Factor = Antenna factor + Cable loss – Amplifier gain.
6. The average measurement was not performed when the peak measured data under the limit of average detection.
7. The emission levels of other frequencies are very lower than the limit and not show in test report.

Product : Intel® Dual Band Wireless-AC 8260  
 Test Item : Harmonic Radiated Emission Data  
 Test Site : No.3 OATS  
 Test Mode : Mode 4 Beamforming: Transmit - 802.11n-20BW\_14.4Mbps(2.4G Band) (2452 MHz)

Frequency MHz	Correct Factor dB	Reading Level dBuV	Measurement Level dBuV/m	Margin dB	Limit dBuV/m
<b>Horizontal</b>					
<b>Peak Detector:</b>					
4904.000	2.914	38.690	41.605	-32.395	74.000
7356.000	11.995	37.440	49.434	-24.566	74.000
9808.000	12.475	37.080	49.555	-24.445	74.000
<b>Average Detector:</b>					
--					
<b>Vertical</b>					
<b>Peak Detector:</b>					
4904.000	5.530	40.660	46.191	-27.809	74.000
7356.000	13.005	38.470	51.474	-22.526	74.000
9808.000	12.901	36.320	49.221	-24.779	74.000
<b>Average Detector:</b>					
--					

Note:

1. All Readings below 1GHz are Quasi-Peak, above 1GHz are performed with peak and/or average measurements as necessary.
2. Peak measurements: RBW = 1MHz, VBW = 3 MHz, Sweep: Auto.
3. Average measurements: RBW = 1MHz, VBW = 10 Hz, Sweep: Auto.
4. Measurement Level = Reading Level + Correct Factor.
5. Correct Factor = Antenna factor + Cable loss – Amplifier gain.
6. The average measurement was not performed when the peak measured data under the limit of average detection.
7. The emission levels of other frequencies are very lower than the limit and not show in test report.



Product : Intel® Dual Band Wireless-AC 8260  
 Test Item : Harmonic Radiated Emission Data  
 Test Site : No.3 OATS  
 Test Mode : Mode 4 Beamforming: Transmit - 802.11n-20BW\_14.4Mbps(2.4G Band) (2457 MHz)

Frequency MHz	Correct Factor dB	Reading Level dBuV	Measurement Level dBuV/m	Margin dB	Limit dBuV/m
<b>Horizontal</b>					
<b>Peak Detector:</b>					
4914.000	2.883	38.150	41.033	-32.967	74.000
7371.000	12.062	36.770	48.832	-25.168	74.000
9828.000	12.664	36.690	49.354	-24.646	74.000
<b>Average Detector:</b>					
--					
<b>Vertical</b>					
<b>Peak Detector:</b>					
4914.000	5.508	37.760	43.268	-30.732	74.000
7371.000	13.130	36.860	49.990	-24.010	74.000
9828.000	13.135	36.610	49.745	-24.255	74.000
<b>Average Detector:</b>					
--					

Note:

1. All Readings below 1GHz are Quasi-Peak, above 1GHz are performed with peak and/or average measurements as necessary.
2. Peak measurements: RBW = 1MHz, VBW = 3 MHz, Sweep: Auto.
3. Average measurements: RBW = 1MHz, VBW = 10 Hz, Sweep: Auto.
4. Measurement Level = Reading Level + Correct Factor.
5. Correct Factor = Antenna factor + Cable loss –Amplifier gain.
6. The average measurement was not performed when the peak measured data under the limit of average detection.
7. The emission levels of other frequencies are very lower than the limit and not show in test report.

Product : Intel® Dual Band Wireless-AC 8260  
Test Item : Harmonic Radiated Emission Data  
Test Site : No.3 OATS  
Test Mode : Mode 4 Beamforming: Transmit - 802.11n-20BW\_14.4Mbps(5G Band) (5745MHz)

Frequency MHz	Correct Factor dB	Reading Level dBuV	Measurement Level dBuV/m	Margin dB	Limit dBuV/m
<b>Horizontal</b>					
<b>Peak Detector:</b>					
11490.000	17.106	35.640	52.747	-21.253	74.000
<b>Average Detector:</b>					
--					
<b>Vertical</b>					
<b>Peak Detector:</b>					
11490.000	18.034	35.470	53.505	-20.495	74.000
<b>Average Detector:</b>					
--					

Note:

1. All Readings below 1GHz are Quasi-Peak, above 1GHz are performed with peak and/or average measurements as necessary.
2. Peak measurements: RBW = 1MHz, VBW = 3 MHz, Sweep: Auto.
3. Average measurements: RBW = 1MHz, VBW = 10 Hz, Sweep: Auto.
4. Measurement Level = Reading Level + Correct Factor.
5. Correct Factor = Antenna factor + Cable loss –Amplifier gain.
6. The average measurement was not performed when the peak measured data under the limit of average detection.
7. The emission levels of other frequencies are very lower than the limit and not show in test report.

Product : Intel® Dual Band Wireless-AC 8260  
Test Item : Harmonic Radiated Emission Data  
Test Site : No.3 OATS  
Test Mode : Mode 4 Beamforming: Transmit - 802.11n-20BW\_14.4Mbps(5G Band) (5785 MHz)

Frequency MHz	Correct Factor dB	Reading Level dBuV	Measurement Level dBuV/m	Margin dB	Limit dBuV/m
<b>Horizontal</b>					
<b>Peak Detector:</b>					
11570.000	16.809	35.480	52.289	-21.711	74.000
<b>Average Detector:</b>					
--					
<b>Vertical</b>					
<b>Peak Detector:</b>					
11570.000	17.698	36.080	53.778	-20.222	74.000
<b>Average Detector:</b>					
--					

Note:

1. All Readings below 1GHz are Quasi-Peak, above 1GHz are performed with peak and/or average measurements as necessary.
2. Peak measurements: RBW = 1MHz, VBW = 3 MHz, Sweep: Auto.
3. Average measurements: RBW = 1MHz, VBW = 10 Hz, Sweep: Auto.
4. Measurement Level = Reading Level + Correct Factor.
5. Correct Factor = Antenna factor + Cable loss –Amplifier gain.
6. The average measurement was not performed when the peak measured data under the limit of average detection.
7. The emission levels of other frequencies are very lower than the limit and not show in test report.

Product : Intel® Dual Band Wireless-AC 8260  
 Test Item : Harmonic Radiated Emission Data  
 Test Site : No.3 OATS  
 Test Mode : Mode 4 Beamforming: Transmit - 802.11n-20BW\_14.4Mbps(5G Band) (5825 MHz)

Frequency MHz	Correct Factor dB	Reading Level dBuV	Measurement Level dBuV/m	Margin dB	Limit dBuV/m
<b>Horizontal</b>					
<b>Peak Detector:</b>					
11650.000	16.158	35.490	51.648	-22.352	74.000
<b>Average Detector:</b>					
--					
<b>Vertical</b>					
<b>Peak Detector:</b>					
11650.000	17.274	35.570	52.845	-21.155	74.000
<b>Average Detector:</b>					
--					

Note:

1. All Readings below 1GHz are Quasi-Peak, above 1GHz are performed with peak and/or average measurements as necessary.
2. Peak measurements: RBW = 1MHz, VBW = 3 MHz, Sweep: Auto.
3. Average measurements: RBW = 1MHz, VBW = 10 Hz, Sweep: Auto.
4. Measurement Level = Reading Level + Correct Factor.
5. Correct Factor = Antenna factor + Cable loss – Amplifier gain.
6. The average measurement was not performed when the peak measured data under the limit of average detection.
7. The emission levels of other frequencies are very lower than the limit and not show in test report.

Product : Intel® Dual Band Wireless-AC 8260  
Test Item : Harmonic Radiated Emission Data  
Test Site : No.3 OATS  
Test Mode : Mode 4 Beamforming: Transmit - 802.11n-40BW\_30Mbps(5G Band) (5755MHz)

Frequency MHz	Correct Factor dB	Reading Level dBuV	Measurement Level dBuV/m	Margin dB	Limit dBuV/m
<b>Horizontal</b>					
<b>Peak Detector:</b>					
11510.000	17.124	35.580	52.704	-21.296	74.000
<b>Average Detector:</b>					
--					
<b>Vertical</b>					
<b>Peak Detector:</b>					
11510.000	18.081	35.620	53.701	-20.299	74.000
<b>Average Detector:</b>					
--					

Note:

1. All Readings below 1GHz are Quasi-Peak, above 1GHz are performed with peak and/or average measurements as necessary.
2. Peak measurements: RBW = 1MHz, VBW = 3 MHz, Sweep: Auto.
3. Average measurements: RBW = 1MHz, VBW = 10 Hz, Sweep: Auto.
4. Measurement Level = Reading Level + Correct Factor.
5. Correct Factor = Antenna factor + Cable loss –Amplifier gain.
6. The average measurement was not performed when the peak measured data under the limit of average detection.
7. The emission levels of other frequencies are very lower than the limit and not show in test report.

Product : Intel® Dual Band Wireless-AC 8260  
Test Item : Harmonic Radiated Emission Data  
Test Site : No.3 OATS  
Test Mode : Mode 4 Beamforming: Transmit - 802.11n-40BW\_30Mbps(5G Band) (5795 MHz)

Frequency MHz	Correct Factor dB	Reading Level dBuV	Measurement Level dBuV/m	Margin dB	Limit dBuV/m
<b>Horizontal</b>					
<b>Peak Detector:</b>					
11590.000	16.701	35.750	52.450	-21.550	74.000
<b>Average Detector:</b>					
--					
<b>Vertical</b>					
<b>Peak Detector:</b>					
--					
<b>Average Detector:</b>					
11590.000	17.567	35.430	52.996	-21.004	74.000

Note:

1. All Readings below 1GHz are Quasi-Peak, above 1GHz are performed with peak and/or average measurements as necessary.
2. Peak measurements: RBW = 1MHz, VBW = 3 MHz, Sweep: Auto.
3. Average measurements: RBW = 1MHz, VBW = 10 Hz, Sweep: Auto.
4. Measurement Level = Reading Level + Correct Factor.
5. Correct Factor = Antenna factor + Cable loss –Amplifier gain.
6. The average measurement was not performed when the peak measured data under the limit of average detection.
7. The emission levels of other frequencies are very lower than the limit and not show in test report.

Product : Intel® Dual Band Wireless-AC 8260  
Test Item : Harmonic Radiated Emission Data  
Test Site : No.3 OATS  
Test Mode : Mode 4 Beamforming: Transmit - 802.11ac-80BW\_65Mbps(5G Band) (5775 MHz)

Frequency MHz	Correct Factor dB	Reading Level dBuV	Measurement Level dBuV/m	Margin dB	Limit dBuV/m
<b>Horizontal</b>					
<b>Peak Detector:</b>					
11550.000	17.018	36.120	53.139	-20.861	74.000
<b>Average Detector:</b>					
--					
<b>Vertical</b>					
<b>Peak Detector:</b>					
11550.000	17.952	35.290	53.243	-20.757	74.000
<b>Average Detector:</b>					
--					

Note:

1. All Readings below 1GHz are Quasi-Peak, above 1GHz are performed with peak and/or average measurements as necessary.
2. Peak measurements: RBW = 1MHz, VBW = 3 MHz, Sweep: Auto.
3. Average measurements: RBW = 1MHz, VBW = 10 Hz, Sweep: Auto.
4. Measurement Level = Reading Level + Correct Factor.
5. Correct Factor = Antenna factor + Cable loss –Amplifier gain.
6. The average measurement was not performed when the peak measured data under the limit of average detection.
7. The emission levels of other frequencies are very lower than the limit and not show in test report.

Product : Intel® Dual Band Wireless-AC 8260  
 Test Item : General Radiated Emission Data  
 Test Site : No.3 OATS  
 Test Mode : Mode 1 SISO A: Transmit (802.11b 1Mbps) (2437 MHz)

Frequency MHz	Correct Factor dB	Reading Level dBuV	Measurement Level dBuV/m	Margin dB	Limit dBuV/m
<b>Horizontal</b>					
159.980	-10.030	38.186	28.155	-15.345	43.500
282.200	-6.074	35.801	29.727	-16.273	46.000
419.940	-0.254	34.961	34.707	-11.293	46.000
602.300	3.794	31.924	35.718	-10.282	46.000
759.440	5.140	31.038	36.178	-9.822	46.000
947.620	6.971	24.158	31.129	-14.871	46.000
<b>Vertical</b>					
179.380	-0.824	30.433	29.609	-13.891	43.500
321.000	-4.153	35.747	31.594	-14.406	46.000
489.780	-2.262	37.144	34.882	-11.118	46.000
643.040	-2.610	38.988	36.378	-9.622	46.000
807.940	3.361	34.120	37.481	-8.519	46.000
968.960	3.936	27.294	31.230	-22.770	54.000

Note:

1. All Readings below 1GHz are Quasi-Peak, above 1GHz are performed with peak and/or average measurements as necessary.
2. Peak measurements: RBW = 1MHz, VBW = 3 MHz, Sweep: Auto.
3. Average measurements: RBW = 1MHz, VBW = 10 Hz, Sweep: Auto.
4. Measurement Level = Reading Level + Correct Factor.
5. Correct Factor = Antenna factor + Cable loss – Amplifier gain.
6. The average measurement was not performed when the peak measured data under the limit of average detection.
7. The emission levels of other frequencies are very lower than the limit and not show in test report.
8. No emission found between lowest internal used/generated frequency to 30MHz.



Product : Intel® Dual Band Wireless-AC 8260  
 Test Item : General Radiated Emission Data  
 Test Site : No.3 OATS  
 Test Mode : Mode 1 SISO A: Transmit (802.11g 6Mbps) (2437 MHz)

Frequency MHz	Correct Factor dB	Reading Level dBuV	Measurement Level dBuV/m	Margin dB	Limit dBuV/m
<b>Horizontal</b>					
169.680	-9.726	38.574	28.848	-14.652	43.500
307.420	-4.120	37.237	33.117	-12.883	46.000
443.220	-0.031	37.987	37.956	-8.044	46.000
598.420	3.524	35.848	39.372	-6.628	46.000
755.560	5.039	34.147	39.186	-6.814	46.000
935.980	6.760	24.583	31.343	-14.657	46.000
<b>Vertical</b>					
179.380	-0.824	31.506	30.682	-12.818	43.500
303.540	-3.998	40.029	36.031	-9.969	46.000
460.680	-1.930	39.563	37.633	-8.367	46.000
594.540	0.175	38.185	38.360	-7.640	46.000
807.940	3.361	34.900	38.261	-7.739	46.000
967.020	3.889	26.221	30.110	-23.890	54.000

Note:

1. All Readings below 1GHz are Quasi-Peak, above 1GHz are performed with peak and/or average measurements as necessary.
2. Peak measurements: RBW = 1MHz, VBW = 3 MHz, Sweep: Auto.
3. Average measurements: RBW = 1MHz, VBW = 10 Hz, Sweep: Auto.
4. Measurement Level = Reading Level + Correct Factor.
5. Correct Factor = Antenna factor + Cable loss – Amplifier gain.
6. The average measurement was not performed when the peak measured data under the limit of average detection.
7. The emission levels of other frequencies are very lower than the limit and not show in test report.
8. No emission found between lowest internal used/generated frequency to 30MHz.

Product : Intel® Dual Band Wireless-AC 8260  
 Test Item : General Radiated Emission Data  
 Test Site : No.3 OATS  
 Test Mode : Mode 1 SISO A: Transmit - 802.11a 6Mbps (5785MHz)

Frequency MHz	Correct Factor dB	Reading Level dBuV	Measurement Level dBuV/m	Margin dB	Limit dBuV/m
<b>Horizontal</b>					
171.620	-9.641	37.480	27.839	-15.661	43.500
305.480	-3.836	36.049	32.213	-13.787	46.000
452.920	1.290	32.886	34.176	-11.824	46.000
621.700	1.817	35.376	37.193	-8.807	46.000
782.720	5.387	30.871	36.258	-9.742	46.000
967.020	7.299	23.716	31.015	-22.985	54.000
<b>Vertical</b>					
191.020	-5.629	30.341	24.712	-18.788	43.500
353.980	-1.124	31.893	30.769	-15.231	46.000
515.000	0.081	34.499	34.580	-11.420	46.000
670.200	-0.898	37.233	36.335	-9.665	46.000
780.780	2.769	33.138	35.907	-10.093	46.000
937.920	3.110	26.465	29.575	-16.425	46.000

Note:

1. All Readings below 1GHz are Quasi-Peak, above 1GHz are performed with peak and/or average measurements as necessary.
2. Peak measurements: RBW = 1MHz, VBW = 3 MHz, Sweep: Auto.
3. Average measurements: RBW = 1MHz, VBW = 10 Hz, Sweep: Auto.
4. Measurement Level = Reading Level + Correct Factor.
5. Correct Factor = Antenna factor + Cable loss – Amplifier gain.
6. The average measurement was not performed when the peak measured data under the limit of average detection.
7. The emission levels of other frequencies are very lower than the limit and not show in test report.
8. No emission found between lowest internal used/generated frequency to 30MHz.

Product : Intel® Dual Band Wireless-AC 8260  
 Test Item : General Radiated Emission Data  
 Test Site : No.3 OATS  
 Test Mode : Mode 1 SISO A: Transmit - 802.11n-20BW\_7.2Mbps(2.4G Band) (2437 MHz)

Frequency MHz	Correct Factor dB	Reading Level dBuV	Measurement Level dBuV/m	Margin dB	Limit dBuV/m
<b>Horizontal</b>					
191.020	-9.679	39.073	29.394	-14.106	43.500
353.980	-1.274	35.338	34.064	-11.936	46.000
483.960	1.462	36.360	37.822	-8.178	46.000
639.160	1.046	36.602	37.648	-8.352	46.000
784.660	5.526	32.493	38.019	-7.981	46.000
955.380	6.596	24.460	31.056	-14.944	46.000
<b>Vertical</b>					
189.080	-5.617	35.877	30.260	-13.240	43.500
330.700	-2.244	38.894	36.651	-9.349	46.000
493.660	-1.656	39.588	37.933	-8.067	46.000
668.260	-0.927	38.297	37.370	-8.630	46.000
821.520	3.036	34.306	37.342	-8.658	46.000
965.080	3.832	28.496	32.328	-21.672	54.000

Note:

1. All Readings below 1GHz are Quasi-Peak, above 1GHz are performed with peak and/or average measurements as necessary.
2. Peak measurements: RBW = 1MHz, VBW = 3 MHz, Sweep: Auto.
3. Average measurements: RBW = 1MHz, VBW = 10 Hz, Sweep: Auto.
4. Measurement Level = Reading Level + Correct Factor.
5. Correct Factor = Antenna factor + Cable loss – Amplifier gain.
6. The average measurement was not performed when the peak measured data under the limit of average detection.
7. The emission levels of other frequencies are very lower than the limit and not show in test report.
8. No emission found between lowest internal used/generated frequency to 30MHz.

Product : Intel® Dual Band Wireless-AC 8260  
 Test Item : General Radiated Emission Data  
 Test Site : No.3 OATS  
 Test Mode : Mode 1 SISO A: Transmit - 802.11n-40BW\_15Mbps(2.4G Band) (2437 MHz)

Frequency MHz	Correct Factor dB	Reading Level dBuV	Measurement Level dBuV/m	Margin dB	Limit dBuV/m
<b>Horizontal</b>					
189.080	-10.027	39.345	29.318	-14.182	43.500
338.460	-3.380	36.385	33.004	-12.996	46.000
489.780	1.498	34.786	36.284	-9.716	46.000
625.580	1.419	35.397	36.817	-9.183	46.000
792.420	6.391	30.319	36.710	-9.290	46.000
963.140	7.021	23.846	30.867	-23.133	54.000
<b>Vertical</b>					
192.960	-5.655	35.615	29.960	-13.540	43.500
346.220	-0.527	33.592	33.065	-12.935	46.000
489.780	-2.262	39.043	36.781	-9.219	46.000
644.980	-3.223	40.272	37.049	-8.951	46.000
790.480	2.693	34.319	37.012	-8.988	46.000
949.560	3.156	31.846	35.002	-10.998	46.000

Note:

1. All Readings below 1GHz are Quasi-Peak, above 1GHz are performed with peak and/or average measurements as necessary.
2. Peak measurements: RBW = 1MHz, VBW = 3 MHz, Sweep: Auto.
3. Average measurements: RBW = 1MHz, VBW = 10 Hz, Sweep: Auto.
4. Measurement Level = Reading Level + Correct Factor.
5. Correct Factor = Antenna factor + Cable loss – Amplifier gain.
6. The average measurement was not performed when the peak measured data under the limit of average detection.
7. The emission levels of other frequencies are very lower than the limit and not show in test report.
8. No emission found between lowest internal used/generated frequency to 30MHz.

Product : Intel® Dual Band Wireless-AC 8260  
 Test Item : General Radiated Emission Data  
 Test Site : No.3 OATS  
 Test Mode : Mode 1 SISO A: Transmit - 802.11n-20BW\_7.2Mbps(5G Band) (5785 MHz)

Frequency MHz	Correct Factor dB	Reading Level dBuV	Measurement Level dBuV/m	Margin dB	Limit dBuV/m
<b>Horizontal</b>					
177.440	-10.838	36.887	26.049	-17.451	43.500
332.640	-3.895	37.220	33.325	-12.675	46.000
464.560	2.914	34.355	37.269	-8.731	46.000
606.180	4.196	34.326	38.522	-7.478	46.000
749.740	3.963	33.395	37.358	-8.642	46.000
937.920	6.750	25.455	32.205	-13.795	46.000
<b>Vertical</b>					
191.020	-5.629	31.172	25.543	-17.957	43.500
330.700	-2.244	34.976	32.733	-13.267	46.000
462.620	-2.571	39.579	37.008	-8.992	46.000
619.760	0.474	34.959	35.433	-10.567	46.000
776.900	2.067	35.297	37.364	-8.636	46.000
953.440	3.015	28.132	31.147	-14.853	46.000

Note:

1. All Readings below 1GHz are Quasi-Peak, above 1GHz are performed with peak and/or average measurements as necessary.
2. Peak measurements: RBW = 1MHz, VBW = 3 MHz, Sweep: Auto.
3. Average measurements: RBW = 1MHz, VBW = 10 Hz, Sweep: Auto.
4. Measurement Level = Reading Level + Correct Factor.
5. Correct Factor = Antenna factor + Cable loss – Amplifier gain.
6. The average measurement was not performed when the peak measured data under the limit of average detection.
7. The emission levels of other frequencies are very lower than the limit and not show in test report.
8. No emission found between lowest internal used/generated frequency to 30MHz.

Product : Intel® Dual Band Wireless-AC 8260  
 Test Item : General Radiated Emission Data  
 Test Site : No.3 OATS  
 Test Mode : Mode 1 SISO A: Transmit - 802.11n-40BW\_15Mbps(5G Band) (5755MHz)

Frequency MHz	Correct Factor dB	Reading Level dBuV	Measurement Level dBuV/m	Margin dB	Limit dBuV/m
<b>Horizontal</b>					
189.080	-10.027	39.345	29.318	-14.182	43.500
338.460	-3.380	36.385	33.004	-12.996	46.000
489.780	1.498	34.786	36.284	-9.716	46.000
625.580	1.419	35.397	36.817	-9.183	46.000
792.420	6.391	30.319	36.710	-9.290	46.000
963.140	7.021	23.846	30.867	-23.133	54.000
<b>Vertical</b>					
192.960	-5.655	35.615	29.960	-13.540	43.500
346.220	-0.527	33.592	33.065	-12.935	46.000
489.780	-2.262	39.043	36.781	-9.219	46.000
644.980	-3.223	40.272	37.049	-8.951	46.000
790.480	2.693	34.319	37.012	-8.988	46.000
949.560	3.156	31.846	35.002	-10.998	46.000

Note:

1. All Readings below 1GHz are Quasi-Peak, above 1GHz are performed with peak and/or average measurements as necessary.
2. Peak measurements: RBW = 1MHz, VBW = 3 MHz, Sweep: Auto.
3. Average measurements: RBW = 1MHz, VBW = 10 Hz, Sweep: Auto.
4. Measurement Level = Reading Level + Correct Factor.
5. Correct Factor = Antenna factor + Cable loss – Amplifier gain.
6. The average measurement was not performed when the peak measured data under the limit of average detection.
7. The emission levels of other frequencies are very lower than the limit and not show in test report.
8. No emission found between lowest internal used/generated frequency to 30MHz.

Product : Intel® Dual Band Wireless-AC 8260  
 Test Item : General Radiated Emission Data  
 Test Site : No.3 OATS  
 Test Mode : Mode 1 SISO A: Transmit - 802.11ac-80BW\_32.5Mbps(5G Band) (5775MHz)

Frequency MHz	Correct Factor dB	Reading Level dBuV	Measurement Level dBuV/m	Margin dB	Limit dBuV/m
<b>Horizontal</b>					
189.080	-10.027	38.883	28.856	-14.644	43.500
324.880	-4.510	39.531	35.021	-10.979	46.000
456.800	2.432	36.138	38.570	-7.430	46.000
637.220	1.572	37.089	38.661	-7.339	46.000
780.780	5.259	32.293	37.552	-8.448	46.000
935.980	6.760	25.113	31.873	-14.127	46.000
<b>Vertical</b>					
185.200	-5.401	33.407	28.006	-15.494	43.500
313.240	-4.090	38.151	34.061	-11.939	46.000
464.560	-3.486	39.325	35.839	-10.161	46.000
629.460	-1.028	39.929	38.901	-7.099	46.000
807.940	3.361	34.935	38.296	-7.704	46.000
965.080	3.832	27.496	31.328	-22.672	54.000

Note:

1. All Readings below 1GHz are Quasi-Peak, above 1GHz are performed with peak and/or average measurements as necessary.
2. Peak measurements: RBW = 1MHz, VBW = 3 MHz, Sweep: Auto.
3. Average measurements: RBW = 1MHz, VBW = 10 Hz, Sweep: Auto.
4. Measurement Level = Reading Level + Correct Factor.
5. Correct Factor = Antenna factor + Cable loss – Amplifier gain.
6. The average measurement was not performed when the peak measured data under the limit of average detection.
7. The emission levels of other frequencies are very lower than the limit and not show in test report.
8. No emission found between lowest internal used/generated frequency to 30MHz.

Product : Intel® Dual Band Wireless-AC 8260  
 Test Item : General Radiated Emission Data  
 Test Site : No.3 OATS  
 Test Mode : Mode 2 SISO B: Transmit (802.11b 1Mbps) (2437 MHz)

Frequency MHz	Correct Factor dB	Reading Level dBuV	Measurement Level dBuV/m	Margin dB	Limit dBuV/m
<b>Horizontal</b>					
177.440	-10.838	38.160	27.322	-16.178	43.500
303.540	-4.068	37.610	33.542	-12.458	46.000
450.980	0.835	37.093	37.928	-8.072	46.000
588.720	3.289	35.484	38.773	-7.227	46.000
751.680	4.332	33.997	38.329	-7.671	46.000
941.800	6.790	23.542	30.332	-15.668	46.000
<b>Vertical</b>					
185.200	-5.401	34.237	28.836	-14.664	43.500
317.120	-4.119	38.562	34.442	-11.558	46.000
470.380	-3.540	42.280	38.740	-7.260	46.000
633.340	-1.450	39.087	37.637	-8.363	46.000
782.720	2.757	34.743	37.500	-8.500	46.000
968.960	3.936	27.268	31.204	-22.796	54.000

Note:

1. All Readings below 1GHz are Quasi-Peak, above 1GHz are performed with peak and/or average measurements as necessary.
2. Peak measurements: RBW = 1MHz, VBW = 3 MHz, Sweep: Auto.
3. Average measurements: RBW = 1MHz, VBW = 10 Hz, Sweep: Auto.
4. Measurement Level = Reading Level + Correct Factor.
5. Correct Factor = Antenna factor + Cable loss – Amplifier gain.
6. The average measurement was not performed when the peak measured data under the limit of average detection.
7. The emission levels of other frequencies are very lower than the limit and not show in test report.
8. No emission found between lowest internal used/generated frequency to 30MHz.



Product : Intel® Dual Band Wireless-AC 8260  
 Test Item : General Radiated Emission Data  
 Test Site : No.3 OATS  
 Test Mode : Mode 2 SISO B: Transmit (802.11g 6Mbps) (2437 MHz)

Frequency MHz	Correct Factor dB	Reading Level dBuV	Measurement Level dBuV/m	Margin dB	Limit dBuV/m
<b>Horizontal</b>					
200.720	-9.846	40.264	30.418	-13.082	43.500
338.460	-3.380	37.621	34.240	-11.760	46.000
472.320	2.932	34.830	37.762	-8.238	46.000
623.640	1.606	36.070	37.676	-8.324	46.000
769.140	5.118	31.094	36.212	-9.788	46.000
941.800	6.790	24.480	31.270	-14.730	46.000
<b>Vertical</b>					
185.200	-5.401	36.803	31.402	-12.098	43.500
324.880	-3.120	38.198	35.078	-10.922	46.000
478.140	-3.423	40.231	36.808	-9.192	46.000
643.040	-2.610	38.962	36.352	-9.648	46.000
800.180	2.637	35.338	37.975	-8.025	46.000
961.200	3.310	27.348	30.658	-23.342	54.000

Note:

1. All Readings below 1GHz are Quasi-Peak, above 1GHz are performed with peak and/or average measurements as necessary.
2. Peak measurements: RBW = 1MHz, VBW = 3 MHz, Sweep: Auto.
3. Average measurements: RBW = 1MHz, VBW = 10 Hz, Sweep: Auto.
4. Measurement Level = Reading Level + Correct Factor.
5. Correct Factor = Antenna factor + Cable loss – Amplifier gain.
6. The average measurement was not performed when the peak measured data under the limit of average detection.
7. The emission levels of other frequencies are very lower than the limit and not show in test report.
8. No emission found between lowest internal used/generated frequency to 30MHz.

Product : Intel® Dual Band Wireless-AC 8260  
 Test Item : General Radiated Emission Data  
 Test Site : No.3 OATS  
 Test Mode : Mode 2 SISO B: Transmit - 802.11a 6Mbps (5785MHz)

Frequency MHz	Correct Factor dB	Reading Level dBuV	Measurement Level dBuV/m	Margin dB	Limit dBuV/m
<b>Horizontal</b>					
200.720	-9.846	39.662	29.816	-13.684	43.500
295.780	-4.747	40.306	35.559	-10.441	46.000
433.520	0.841	37.814	38.655	-7.345	46.000
575.140	3.025	35.993	39.018	-6.982	46.000
761.380	5.145	33.893	39.037	-6.963	46.000
953.440	6.735	22.050	28.785	-17.215	46.000
<b>Vertical</b>					
206.540	-5.509	36.892	31.383	-12.117	43.500
336.520	-1.999	38.133	36.134	-9.866	46.000
468.440	-3.566	39.207	35.641	-10.359	46.000
639.160	-1.374	38.829	37.455	-8.545	46.000
827.340	2.711	35.600	38.311	-7.689	46.000
949.560	3.156	32.502	35.658	-10.342	46.000

Note:

1. All Readings below 1GHz are Quasi-Peak, above 1GHz are performed with peak and/or average measurements as necessary.
2. Peak measurements: RBW = 1MHz, VBW = 3 MHz, Sweep: Auto.
3. Average measurements: RBW = 1MHz, VBW = 10 Hz, Sweep: Auto.
4. Measurement Level = Reading Level + Correct Factor.
5. Correct Factor = Antenna factor + Cable loss – Amplifier gain.
6. The average measurement was not performed when the peak measured data under the limit of average detection.
7. The emission levels of other frequencies are very lower than the limit and not show in test report.
8. No emission found between lowest internal used/generated frequency to 30MHz.

Product : Intel® Dual Band Wireless-AC 8260  
 Test Item : General Radiated Emission Data  
 Test Site : No.3 OATS  
 Test Mode : Mode 2 SISO B: Transmit - 802.11n-20BW\_7.2Mbps(2.4G Band) (2437 MHz)

Frequency MHz	Correct Factor dB	Reading Level dBuV	Measurement Level dBuV/m	Margin dB	Limit dBuV/m
<b>Horizontal</b>					
175.500	-9.792	41.582	31.790	-11.710	43.500
315.180	-4.628	41.068	36.440	-9.560	46.000
464.560	2.914	35.122	38.036	-7.964	46.000
617.820	2.438	35.031	37.469	-8.531	46.000
765.260	5.091	32.119	37.210	-8.790	46.000
935.980	6.760	23.996	30.756	-15.244	46.000
<b>Vertical</b>					
202.660	-5.573	37.642	32.070	-11.430	43.500
338.460	-1.640	38.913	37.272	-8.728	46.000
472.320	-3.508	40.938	37.430	-8.570	46.000
615.880	1.473	37.615	39.088	-6.912	46.000
788.540	2.714	36.100	38.814	-7.186	46.000
968.960	3.936	26.253	30.189	-23.811	54.000

Note:

1. All Readings below 1GHz are Quasi-Peak, above 1GHz are performed with peak and/or average measurements as necessary.
2. Peak measurements: RBW = 1MHz, VBW = 3 MHz, Sweep: Auto.
3. Average measurements: RBW = 1MHz, VBW = 10 Hz, Sweep: Auto.
4. Measurement Level = Reading Level + Correct Factor.
5. Correct Factor = Antenna factor + Cable loss – Amplifier gain.
6. The average measurement was not performed when the peak measured data under the limit of average detection.
7. The emission levels of other frequencies are very lower than the limit and not show in test report.
8. No emission found between lowest internal used/generated frequency to 30MHz.

Product : Intel® Dual Band Wireless-AC 8260  
 Test Item : General Radiated Emission Data  
 Test Site : No.3 OATS  
 Test Mode : Mode 2 SISO B: Transmit - 802.11n-40BW\_15Mbps(2.4G Band) (2437 MHz)

Frequency MHz	Correct Factor dB	Reading Level dBuV	Measurement Level dBuV/m	Margin dB	Limit dBuV/m
<b>Horizontal</b>					
187.140	-11.217	36.461	25.244	-18.256	43.500
309.360	-4.463	35.851	31.388	-14.612	46.000
447.100	-0.067	37.058	36.991	-9.009	46.000
604.240	4.289	34.548	38.838	-7.162	46.000
767.200	5.099	32.627	37.727	-8.273	46.000
943.740	6.843	24.056	30.899	-15.101	46.000
<b>Vertical</b>					
179.380	-0.824	29.595	28.771	-14.729	43.500
309.360	-4.043	37.502	33.459	-12.541	46.000
476.200	-3.462	39.296	35.834	-10.166	46.000
629.460	-1.028	36.950	35.922	-10.078	46.000
794.360	2.657	34.955	37.612	-8.388	46.000
967.020	3.889	27.357	31.246	-22.754	54.000

Note:

1. All Readings below 1GHz are Quasi-Peak, above 1GHz are performed with peak and/or average measurements as necessary.
2. Peak measurements: RBW = 1MHz, VBW = 3 MHz, Sweep: Auto.
3. Average measurements: RBW = 1MHz, VBW = 10 Hz, Sweep: Auto.
4. Measurement Level = Reading Level + Correct Factor.
5. Correct Factor = Antenna factor + Cable loss – Amplifier gain.
6. The average measurement was not performed when the peak measured data under the limit of average detection.
7. The emission levels of other frequencies are very lower than the limit and not show in test report.
8. No emission found between lowest internal used/generated frequency to 30MHz.

Product : Intel® Dual Band Wireless-AC 8260  
 Test Item : General Radiated Emission Data  
 Test Site : No.3 OATS  
 Test Mode : Mode 2 SISO B: Transmit - 802.11n-20BW\_7.2Mbps(5G Band) (5785 MHz)

Frequency MHz	Correct Factor dB	Reading Level dBuV	Measurement Level dBuV/m	Margin dB	Limit dBuV/m
<b>Horizontal</b>					
173.560	-9.543	39.110	29.567	-13.933	43.500
342.340	-2.566	35.463	32.897	-13.103	46.000
464.560	2.914	33.900	36.814	-9.186	46.000
621.700	1.817	36.564	38.381	-7.619	46.000
767.200	5.099	33.337	38.437	-7.563	46.000
926.280	6.832	25.212	32.044	-13.956	46.000
<b>Vertical</b>					
173.560	-2.713	28.086	25.373	-18.127	43.500
321.000	-4.153	36.414	32.261	-13.739	46.000
516.940	0.380	36.172	36.552	-9.448	46.000
627.520	-0.327	37.748	37.421	-8.579	46.000
743.920	0.718	37.022	37.740	-8.260	46.000
920.460	3.272	27.501	30.773	-15.227	46.000

Note:

1. All Readings below 1GHz are Quasi-Peak, above 1GHz are performed with peak and/or average measurements as necessary.
2. Peak measurements: RBW = 1MHz, VBW = 3 MHz, Sweep: Auto.
3. Average measurements: RBW = 1MHz, VBW = 10 Hz, Sweep: Auto.
4. Measurement Level = Reading Level + Correct Factor.
5. Correct Factor = Antenna factor + Cable loss – Amplifier gain.
6. The average measurement was not performed when the peak measured data under the limit of average detection.
7. The emission levels of other frequencies are very lower than the limit and not show in test report.
8. No emission found between lowest internal used/generated frequency to 30MHz.

Product : Intel® Dual Band Wireless-AC 8260  
 Test Item : General Radiated Emission Data  
 Test Site : No.3 OATS  
 Test Mode : Mode 2 SISO B: Transmit - 802.11n-40BW\_15Mbps(5G Band) (5755MHz)

Frequency MHz	Correct Factor dB	Reading Level dBuV	Measurement Level dBuV/m	Margin dB	Limit dBuV/m
<b>Horizontal</b>					
187.140	-11.217	36.461	25.244	-18.256	43.500
309.360	-4.463	35.851	31.388	-14.612	46.000
447.100	-0.067	37.058	36.991	-9.009	46.000
604.240	4.289	34.548	38.838	-7.162	46.000
767.200	5.099	32.627	37.727	-8.273	46.000
943.740	6.843	24.056	30.899	-15.101	46.000
<b>Vertical</b>					
179.380	-0.824	29.595	28.771	-14.729	43.500
309.360	-4.043	37.502	33.459	-12.541	46.000
476.200	-3.462	39.296	35.834	-10.166	46.000
629.460	-1.028	36.950	35.922	-10.078	46.000
794.360	2.657	34.955	37.612	-8.388	46.000
967.020	3.889	27.357	31.246	-22.754	54.000

Note:

1. All Readings below 1GHz are Quasi-Peak, above 1GHz are performed with peak and/or average measurements as necessary.
2. Peak measurements: RBW = 1MHz, VBW = 3 MHz, Sweep: Auto.
3. Average measurements: RBW = 1MHz, VBW = 10 Hz, Sweep: Auto.
4. Measurement Level = Reading Level + Correct Factor.
5. Correct Factor = Antenna factor + Cable loss – Amplifier gain.
6. The average measurement was not performed when the peak measured data under the limit of average detection.
7. The emission levels of other frequencies are very lower than the limit and not show in test report.
8. No emission found between lowest internal used/generated frequency to 30MHz.

Product : Intel® Dual Band Wireless-AC 8260  
 Test Item : General Radiated Emission Data  
 Test Site : No.3 OATS  
 Test Mode : Mode 2 SISO B: Transmit - 802.11ac-80BW\_32.5Mbps(5G Band) (5775MHz)

Frequency MHz	Correct Factor dB	Reading Level dBuV	Measurement Level dBuV/m	Margin dB	Limit dBuV/m
<b>Horizontal</b>					
189.080	-10.027	36.779	26.752	-16.748	43.500
324.880	-4.510	37.182	32.672	-13.328	46.000
441.280	0.444	36.733	37.177	-8.823	46.000
594.540	3.555	34.568	38.123	-7.877	46.000
767.200	5.099	32.909	38.009	-7.991	46.000
937.920	6.750	24.580	31.330	-14.670	46.000
<b>Vertical</b>					
191.020	-5.629	33.167	27.538	-15.962	43.500
350.100	-1.278	34.837	33.559	-12.441	46.000
489.780	-2.262	39.102	36.840	-9.160	46.000
639.160	-1.374	38.759	37.385	-8.615	46.000
802.120	2.966	35.565	38.531	-7.469	46.000
968.960	3.936	28.142	32.078	-21.922	54.000

Note:

1. All Readings below 1GHz are Quasi-Peak, above 1GHz are performed with peak and/or average measurements as necessary.
2. Peak measurements: RBW = 1MHz, VBW = 3 MHz, Sweep: Auto.
3. Average measurements: RBW = 1MHz, VBW = 10 Hz, Sweep: Auto.
4. Measurement Level = Reading Level + Correct Factor.
5. Correct Factor = Antenna factor + Cable loss – Amplifier gain.
6. The average measurement was not performed when the peak measured data under the limit of average detection.
7. The emission levels of other frequencies are very lower than the limit and not show in test report.
8. No emission found between lowest internal used/generated frequency to 30MHz.

Product : Intel® Dual Band Wireless-AC 8260  
 Test Item : General Radiated Emission Data  
 Test Site : No.3 OATS  
 Test Mode : Mode 3 MIMO: Transmit - 802.11n-20BW\_14.4Mbps(2.4G Band) (2437 MHz)

Frequency MHz	Correct Factor dB	Reading Level dBuV	Measurement Level dBuV/m	Margin dB	Limit dBuV/m
<b>Horizontal</b>					
191.020	-9.679	41.111	31.432	-12.068	43.500
322.940	-4.536	41.000	36.465	-9.535	46.000
470.380	3.550	35.543	39.093	-6.907	46.000
619.760	2.074	37.600	39.674	-6.326	46.000
790.480	6.363	31.089	37.452	-8.548	46.000
963.140	7.021	25.493	32.514	-21.486	54.000
<b>Vertical</b>					
181.320	-1.910	35.062	33.152	-10.348	43.500
330.700	-2.244	38.877	36.634	-9.366	46.000
474.260	-3.486	43.224	39.738	-6.262	46.000
623.640	0.376	40.135	40.511	-5.489	46.000
796.300	2.639	34.783	37.422	-8.578	46.000
959.260	3.100	28.991	32.091	-13.909	46.000

Note:

1. All Readings below 1GHz are Quasi-Peak, above 1GHz are performed with peak and/or average measurements as necessary.
2. Peak measurements: RBW = 1MHz, VBW = 3 MHz, Sweep: Auto.
3. Average measurements: RBW = 1MHz, VBW = 10 Hz, Sweep: Auto.
4. Measurement Level = Reading Level + Correct Factor.
5. Correct Factor = Antenna factor + Cable loss – Amplifier gain.
6. The average measurement was not performed when the peak measured data under the limit of average detection.
7. The emission levels of other frequencies are very lower than the limit and not show in test report.
8. No emission found between lowest internal used/generated frequency to 30MHz.



Product : Intel® Dual Band Wireless-AC 8260  
 Test Item : General Radiated Emission Data  
 Test Site : No.3 OATS  
 Test Mode : Mode 3 MIMO: Transmit - 802.11n-40BW\_30Mbps(2.4G Band) (2437 MHz)

Frequency MHz	Correct Factor dB	Reading Level dBuV	Measurement Level dBuV/m	Margin dB	Limit dBuV/m
<b>Horizontal</b>					
177.440	-10.838	40.652	29.814	-13.686	43.500
330.700	-4.284	37.959	33.676	-12.324	46.000
466.500	3.156	35.735	38.891	-7.109	46.000
608.120	3.925	34.098	38.023	-7.977	46.000
782.720	5.387	32.737	38.124	-7.876	46.000
935.980	6.760	25.790	32.550	-13.450	46.000
<b>Vertical</b>					
181.320	-1.910	30.830	28.920	-14.580	43.500
303.540	-3.998	41.355	37.357	-8.643	46.000
454.860	-4.096	42.510	38.413	-7.587	46.000
619.760	0.474	36.993	37.467	-8.533	46.000
796.300	2.639	35.117	37.756	-8.244	46.000
951.500	3.083	29.151	32.234	-13.766	46.000

Note:

1. All Readings below 1GHz are Quasi-Peak, above 1GHz are performed with peak and/or average measurements as necessary.
2. Peak measurements: RBW = 1MHz, VBW = 3 MHz, Sweep: Auto.
3. Average measurements: RBW = 1MHz, VBW = 10 Hz, Sweep: Auto.
4. Measurement Level = Reading Level + Correct Factor.
5. Correct Factor = Antenna factor + Cable loss – Amplifier gain.
6. The average measurement was not performed when the peak measured data under the limit of average detection.
7. The emission levels of other frequencies are very lower than the limit and not show in test report.
8. No emission found between lowest internal used/generated frequency to 30MHz.

Product : Intel® Dual Band Wireless-AC 8260  
 Test Item : General Radiated Emission Data  
 Test Site : No.3 OATS  
 Test Mode : Mode 3 MIMO: Transmit - 802.11n-20BW\_14.4Mbps(5G Band) (5785 MHz)

Frequency MHz	Correct Factor dB	Reading Level dBuV	Measurement Level dBuV/m	Margin dB	Limit dBuV/m
<b>Horizontal</b>					
208.480	-10.485	40.918	30.432	-13.068	43.500
332.640	-3.895	37.497	33.602	-12.398	46.000
454.860	1.754	36.186	37.939	-8.061	46.000
619.760	2.074	36.621	38.695	-7.305	46.000
761.380	5.145	34.185	39.329	-6.671	46.000
951.500	6.993	25.655	32.648	-13.352	46.000
<b>Vertical</b>					
173.560	-2.713	33.487	30.774	-12.726	43.500
282.200	-5.794	38.252	32.458	-13.542	46.000
386.960	-0.708	37.443	36.735	-9.265	46.000
544.100	1.503	36.316	37.819	-8.181	46.000
728.400	-0.799	37.684	36.884	-9.116	46.000
920.460	3.272	27.173	30.445	-15.555	46.000

Note:

1. All Readings below 1GHz are Quasi-Peak, above 1GHz are performed with peak and/or average measurements as necessary.
2. Peak measurements: RBW = 1MHz, VBW = 3 MHz, Sweep: Auto.
3. Average measurements: RBW = 1MHz, VBW = 10 Hz, Sweep: Auto.
4. Measurement Level = Reading Level + Correct Factor.
5. Correct Factor = Antenna factor + Cable loss – Amplifier gain.
6. The average measurement was not performed when the peak measured data under the limit of average detection.
7. The emission levels of other frequencies are very lower than the limit and not show in test report.
8. No emission found between lowest internal used/generated frequency to 30MHz.

Product : Intel® Dual Band Wireless-AC 8260  
 Test Item : General Radiated Emission Data  
 Test Site : No.3 OATS  
 Test Mode : Mode 3 MIMO: Transmit - 802.11n-40BW\_30Mbps(5G Band) (5755MHz)

Frequency MHz	Correct Factor dB	Reading Level dBuV	Measurement Level dBuV/m	Margin dB	Limit dBuV/m
<b>Horizontal</b>					
210.420	-10.427	38.910	28.483	-15.017	43.500
363.680	0.189	33.772	33.961	-12.039	46.000
483.960	1.462	38.174	39.636	-6.364	46.000
625.580	1.419	36.956	38.376	-7.624	46.000
784.660	5.526	32.238	37.764	-8.236	46.000
949.560	7.036	23.409	30.445	-15.555	46.000
<b>Vertical</b>					
183.260	-3.735	31.665	27.930	-15.570	43.500
272.500	-6.388	39.717	33.329	-12.671	46.000
412.180	-5.121	41.204	36.083	-9.917	46.000
619.760	0.474	35.602	36.076	-9.924	46.000
759.440	2.110	35.674	37.784	-8.216	46.000
930.160	3.830	32.412	36.242	-9.758	46.000

Note:

1. All Readings below 1GHz are Quasi-Peak, above 1GHz are performed with peak and/or average measurements as necessary.
2. Peak measurements: RBW = 1MHz, VBW = 3 MHz, Sweep: Auto.
3. Average measurements: RBW = 1MHz, VBW = 10 Hz, Sweep: Auto.
4. Measurement Level = Reading Level + Correct Factor.
5. Correct Factor = Antenna factor + Cable loss – Amplifier gain.
6. The average measurement was not performed when the peak measured data under the limit of average detection.
7. The emission levels of other frequencies are very lower than the limit and not show in test report.
8. No emission found between lowest internal used/generated frequency to 30MHz.

Product : Intel® Dual Band Wireless-AC 8260  
 Test Item : General Radiated Emission Data  
 Test Site : No.3 OATS  
 Test Mode : Mode 3 MIMO: Transmit - 802.11ac-80BW\_65Mbps(5G Band) (5775MHz)

Frequency MHz	Correct Factor dB	Reading Level dBuV	Measurement Level dBuV/m	Margin dB	Limit dBuV/m
<b>Horizontal</b>					
173.560	-9.543	37.789	28.246	-15.254	43.500
324.880	-4.510	38.345	33.835	-12.165	46.000
441.280	0.444	35.161	35.605	-10.395	46.000
598.420	3.524	34.461	37.985	-8.015	46.000
773.020	5.145	31.634	36.779	-9.221	46.000
941.800	6.790	24.365	31.155	-14.845	46.000
<b>Vertical</b>					
194.900	-5.673	33.500	27.827	-15.673	43.500
350.100	-1.278	35.584	34.306	-11.694	46.000
482.020	-3.046	37.911	34.865	-11.135	46.000
629.460	-1.028	38.652	37.624	-8.376	46.000
800.180	2.637	34.437	37.074	-8.926	46.000
953.440	3.015	25.136	28.151	-17.849	46.000

Note:

1. All Readings below 1GHz are Quasi-Peak, above 1GHz are performed with peak and/or average measurements as necessary.
2. Peak measurements: RBW = 1MHz, VBW = 3 MHz, Sweep: Auto.
3. Average measurements: RBW = 1MHz, VBW = 10 Hz, Sweep: Auto.
4. Measurement Level = Reading Level + Correct Factor.
5. Correct Factor = Antenna factor + Cable loss – Amplifier gain.
6. The average measurement was not performed when the peak measured data under the limit of average detection.
7. The emission levels of other frequencies are very lower than the limit and not show in test report.
8. No emission found between lowest internal used/generated frequency to 30MHz.

Product : Intel® Dual Band Wireless-AC 8260  
 Test Item : General Radiated Emission Data  
 Test Site : No.3 OATS  
 Test Mode : Mode 4 Beamforming: Transmit - 802.11n-20BW\_14.4Mbps(2.4G Band) (2437 MHz)

Frequency MHz	Correct Factor dB	Reading Level dBuV	Measurement Level dBuV/m	Margin dB	Limit dBuV/m
<b>Horizontal</b>					
173.560	-9.543	42.876	33.333	-10.167	43.500
307.420	-4.120	34.020	29.900	-16.100	46.000
452.920	1.290	34.994	36.284	-9.716	46.000
586.780	3.246	33.182	36.428	-9.572	46.000
757.500	5.107	22.125	27.232	-18.768	46.000
910.760	6.484	25.449	31.933	-14.067	46.000
<b>Vertical</b>					
192.960	-5.655	27.921	22.266	-21.234	43.500
352.040	-1.292	27.369	26.077	-19.923	46.000
495.600	-1.237	37.736	36.499	-9.501	46.000
631.400	-1.454	38.302	36.848	-9.152	46.000
763.320	1.913	35.257	37.170	-8.830	46.000
914.640	-0.980	27.694	26.714	-19.286	46.000

Note:

1. All Readings below 1GHz are Quasi-Peak, above 1GHz are performed with peak and/or average measurements as necessary.
2. Peak measurements: RBW = 1MHz, VBW = 3 MHz, Sweep: Auto.
3. Average measurements: RBW = 1MHz, VBW = 10 Hz, Sweep: Auto.
4. Measurement Level = Reading Level + Correct Factor.
5. Correct Factor = Antenna factor + Cable loss – Amplifier gain.
6. The average measurement was not performed when the peak measured data under the limit of average detection.
7. The emission levels of other frequencies are very lower than the limit and not show in test report.
8. No emission found between lowest internal used/generated frequency to 30MHz.

Product : Intel® Dual Band Wireless-AC 8260  
 Test Item : General Radiated Emission Data  
 Test Site : No.3 OATS  
 Test Mode : Mode 4 Beamforming: Transmit - 802.11n-40BW\_30Mbps(2.4G Band) (2437 MHz)

Frequency MHz	Correct Factor dB	Reading Level dBuV	Measurement Level dBuV/m	Margin dB	Limit dBuV/m
<b>Horizontal</b>					
227.880	-8.769	32.875	24.107	-21.893	46.000
355.920	-1.242	32.563	31.321	-14.679	46.000
485.900	1.316	35.446	36.762	-9.238	46.000
629.460	1.212	35.402	36.614	-9.386	46.000
778.840	5.180	30.634	35.814	-10.186	46.000
935.980	6.760	21.546	28.306	-17.694	46.000
<b>Vertical</b>					
161.920	-4.964	33.136	28.172	-15.328	43.500
293.840	-4.990	39.587	34.597	-11.403	46.000
441.280	-6.836	44.437	37.601	-8.399	46.000
588.720	-2.201	40.387	38.186	-7.814	46.000
761.380	1.925	36.823	38.747	-7.253	46.000
903.000	1.418	31.631	33.049	-12.951	46.000

Note:

1. All Readings below 1GHz are Quasi-Peak, above 1GHz are performed with peak and/or average measurements as necessary.
2. Peak measurements: RBW = 1MHz, VBW = 3 MHz, Sweep: Auto.
3. Average measurements: RBW = 1MHz, VBW = 10 Hz, Sweep: Auto.
4. Measurement Level = Reading Level + Correct Factor.
5. Correct Factor = Antenna factor + Cable loss – Amplifier gain.
6. The average measurement was not performed when the peak measured data under the limit of average detection.
7. The emission levels of other frequencies are very lower than the limit and not show in test report.
8. No emission found between lowest internal used/generated frequency to 30MHz.

Product : Intel® Dual Band Wireless-AC 8260  
 Test Item : General Radiated Emission Data  
 Test Site : No.3 OATS  
 Test Mode : Mode 4 Beamforming: Transmit - 802.11n-20BW\_14.4Mbps(5G Band) (5785 MHz)

Frequency MHz	Correct Factor dB	Reading Level dBuV	Measurement Level dBuV/m	Margin dB	Limit dBuV/m
<b>Horizontal</b>					
202.660	-10.183	41.337	31.155	-12.345	43.500
322.940	-4.536	38.916	34.381	-11.619	46.000
476.200	1.988	35.890	37.878	-8.122	46.000
617.820	2.438	35.103	37.541	-8.459	46.000
769.140	5.118	31.467	36.585	-9.415	46.000
941.800	6.790	23.844	30.634	-15.366	46.000
<b>Vertical</b>					
187.140	-5.607	30.619	25.012	-18.488	43.500
319.060	-4.135	35.922	31.787	-14.213	46.000
474.260	-3.486	40.626	37.140	-8.860	46.000
631.400	-1.454	34.336	32.882	-13.118	46.000
796.300	2.639	35.890	38.529	-7.471	46.000
968.960	3.936	28.193	32.129	-21.871	54.000

Note:

1. All Readings below 1GHz are Quasi-Peak, above 1GHz are performed with peak and/or average measurements as necessary.
2. Peak measurements: RBW = 1MHz, VBW = 3 MHz, Sweep: Auto.
3. Average measurements: RBW = 1MHz, VBW = 10 Hz, Sweep: Auto.
4. Measurement Level = Reading Level + Correct Factor.
5. Correct Factor = Antenna factor + Cable loss – Amplifier gain.
6. The average measurement was not performed when the peak measured data under the limit of average detection.
7. The emission levels of other frequencies are very lower than the limit and not show in test report.
8. No emission found between lowest internal used/generated frequency to 30MHz.

Product : Intel® Dual Band Wireless-AC 8260  
 Test Item : General Radiated Emission Data  
 Test Site : No.3 OATS  
 Test Mode : Mode 4 Beamforming: Transmit - 802.11n-40BW\_30Mbps(5G Band) (5755MHz)

Frequency MHz	Correct Factor dB	Reading Level dBuV	Measurement Level dBuV/m	Margin dB	Limit dBuV/m
<b>Horizontal</b>					
167.740	-9.816	38.385	28.569	-14.931	43.500
326.820	-4.499	38.054	33.555	-12.445	46.000
449.040	0.386	37.765	38.151	-7.849	46.000
631.400	1.266	35.481	36.747	-9.253	46.000
769.140	5.118	32.463	37.581	-8.419	46.000
945.680	6.910	22.403	29.313	-16.687	46.000
<b>Vertical</b>					
200.720	-5.676	34.764	29.088	-14.412	43.500
361.740	-0.646	33.760	33.113	-12.887	46.000
501.420	-0.101	38.374	38.273	-7.727	46.000
660.500	-1.111	37.368	36.257	-9.743	46.000
811.820	2.851	30.683	33.534	-12.466	46.000
968.960	3.936	25.296	29.232	-24.768	54.000

Note:

1. All Readings below 1GHz are Quasi-Peak, above 1GHz are performed with peak and/or average measurements as necessary.
2. Peak measurements: RBW = 1MHz, VBW = 3 MHz, Sweep: Auto.
3. Average measurements: RBW = 1MHz, VBW = 10 Hz, Sweep: Auto.
4. Measurement Level = Reading Level + Correct Factor.
5. Correct Factor = Antenna factor + Cable loss – Amplifier gain.
6. The average measurement was not performed when the peak measured data under the limit of average detection.
7. The emission levels of other frequencies are very lower than the limit and not show in test report.
8. No emission found between lowest internal used/generated frequency to 30MHz.



Product : Intel® Dual Band Wireless-AC 8260  
 Test Item : General Radiated Emission Data  
 Test Site : No.3 OATS  
 Test Mode : Mode 4 Beamforming: Transmit - 802.11ac-80BW\_65Mbps(5G Band) (5775MHz)

Frequency MHz	Correct Factor dB	Reading Level dBuV	Measurement Level dBuV/m	Margin dB	Limit dBuV/m
<b>Horizontal</b>					
167.740	-9.816	37.930	28.114	-15.386	43.500
299.660	-4.751	37.216	32.465	-13.535	46.000
429.640	0.630	38.180	38.809	-7.191	46.000
588.720	3.289	35.782	39.071	-6.929	46.000
765.260	5.091	32.720	37.811	-8.189	46.000
937.920	6.750	26.168	32.918	-13.082	46.000
<b>Vertical</b>					
177.440	-1.248	32.033	30.785	-12.715	43.500
313.240	-4.090	37.408	33.318	-12.682	46.000
480.080	-3.390	37.904	34.514	-11.486	46.000
610.060	2.087	36.403	38.490	-7.510	46.000
776.900	2.067	37.077	39.144	-6.856	46.000
974.780	-2.051	31.984	29.933	-24.067	54.000

Note:

1. All Readings below 1GHz are Quasi-Peak, above 1GHz are performed with peak and/or average measurements as necessary.
2. Peak measurements: RBW = 1MHz, VBW = 3 MHz, Sweep: Auto.
3. Average measurements: RBW = 1MHz, VBW = 10 Hz, Sweep: Auto.
4. Measurement Level = Reading Level + Correct Factor.
5. Correct Factor = Antenna factor + Cable loss – Amplifier gain.
6. The average measurement was not performed when the peak measured data under the limit of average detection.
7. The emission levels of other frequencies are very lower than the limit and not show in test report.
8. No emission found between lowest internal used/generated frequency to 30MHz.

**5. RF antenna conducted test**

**5.1. Test Equipment**

	Equipment	Manufacturer	Model No./Serial No.	Last Cal.
X	Spectrum Analyzer	R&S	FSP40 / 100170	Jun, 2014
	Spectrum Analyzer	Agilent	E4407B / US39440758	Jun, 2014
	Spectrum Analyzer	Agilent	N9010A / MY48030495	Apr., 2015

- Note:
1. All equipments are calibrated with traceable calibrations. Each calibration is traceable to the national or international standards.
  2. The test instruments marked with “X” are used to measure the final test results.

**5.2. Test Setup**

**RF antenna Conducted Measurement:**

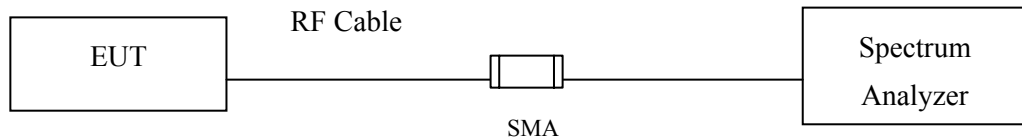

**5.3. Limits**

In any 100 kHz bandwidth outside the frequency band in which the spread spectrum intentional radiator is operating, the radio frequency power that is produced by the intentional radiator shall be at least 20 dB below that in the 100 kHz bandwidth within the band that contains the highest level of the desired power, based on either an RF conducted or a radiated measurement. Attenuation below the general limits specified in Section 15.209(a) is not required. In addition, radiated emissions which fall in the restricted bands, as defined in Section 15.205(a), must also comply with the radiated emission limits specified in Section 15.209(a) (see Section 15.205(c)).

Note: Channel 5775 MHz was tested using the procedure in KDB 558074, section 9.2.2.2.

Non-restricted frequency bands must comply with the KDB 558074, section 11.1 b) requirement.

#### **5.4. Test Procedure**

The EUT was tested according to DTS test procedure of Jan. 2012 KDB558074 for compliance to FCC 47CFR 15.247 requirements.

Set RBW = 100 kHz, Set VBW  $\geq 3 \times$  RBW, scan up through 10th harmonic.

#### **5.5. Uncertainty**

The measurement uncertainty

Conducted is defined as  $\pm 1.27\text{dB}$

**5.6. Test Result of RF antenna conducted test**

Product : Intel® Dual Band Wireless-AC 8260  
 Test Item : RF antenna conducted test  
 Test Site : No.3 OATS  
 Test Mode : Mode 1 SISO A: Transmit (802.11b 1Mbps)

**Channel 01 (2412MHz) 30MHz-25GHz**

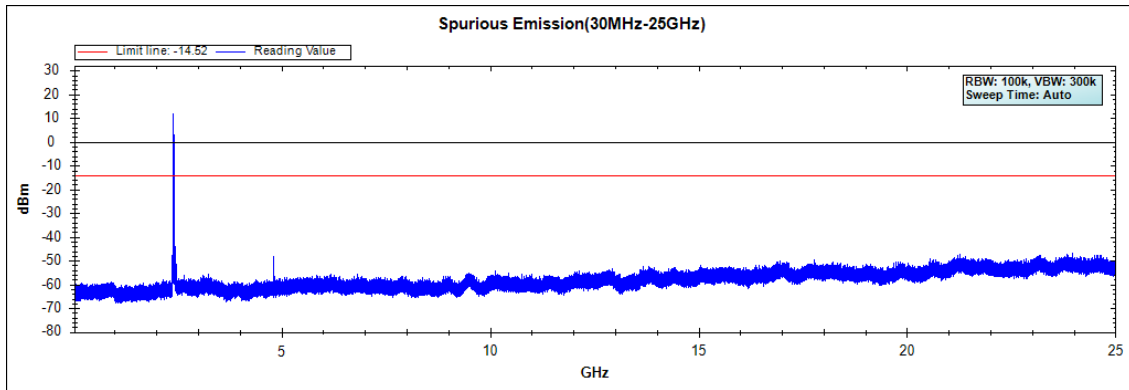

**Channel 06 (2437MHz) 30MHz -25GHz**

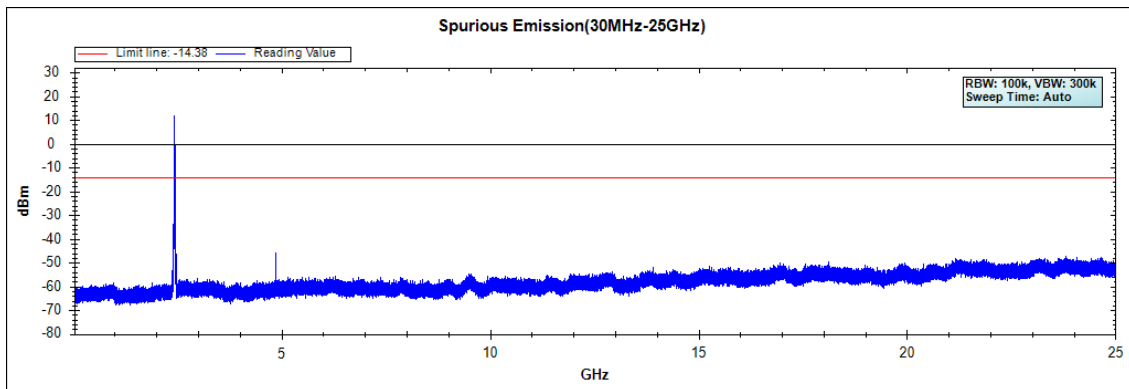

**Channel 11 (2462MHz) 30MHz -25GHz**

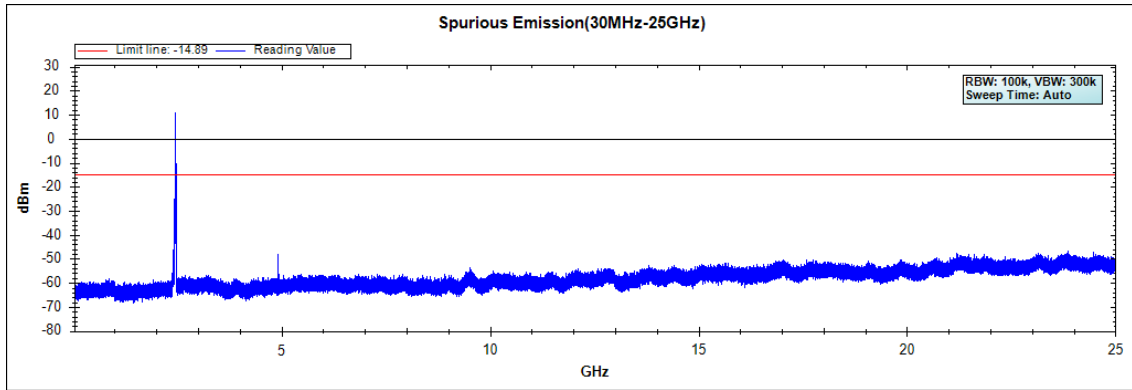

**Channel 12 (2467MHz) 30MHz -25GHz**

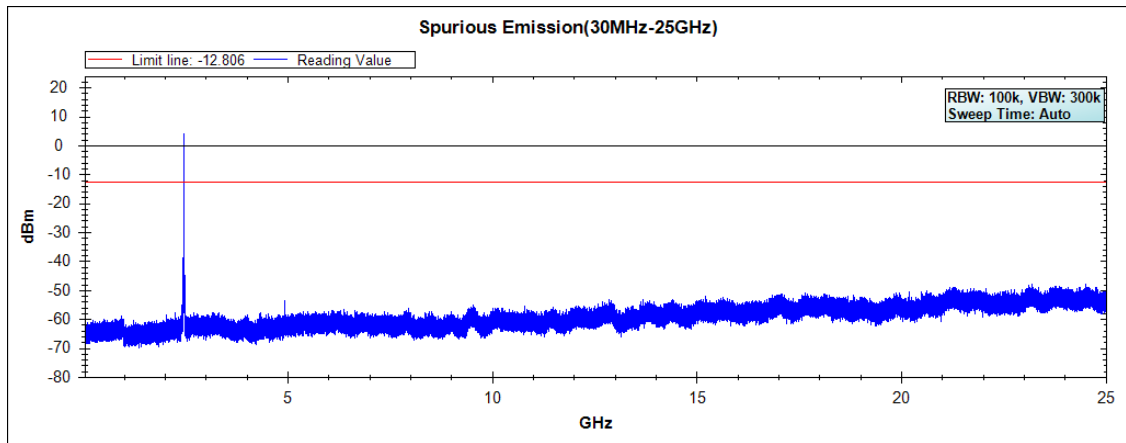

Note: The above test pattern is synthesized by multiple of the frequency range.

Product : Intel® Dual Band Wireless-AC 8260  
Test Item : RF Antenna Conducted Spurious  
Test Site : No.3 OATS  
Test Mode : Mode 1 SISO A: Transmit (802.11g 6Mbps)

**Channel 01 (2412MHz) 30MHz -25GHz**

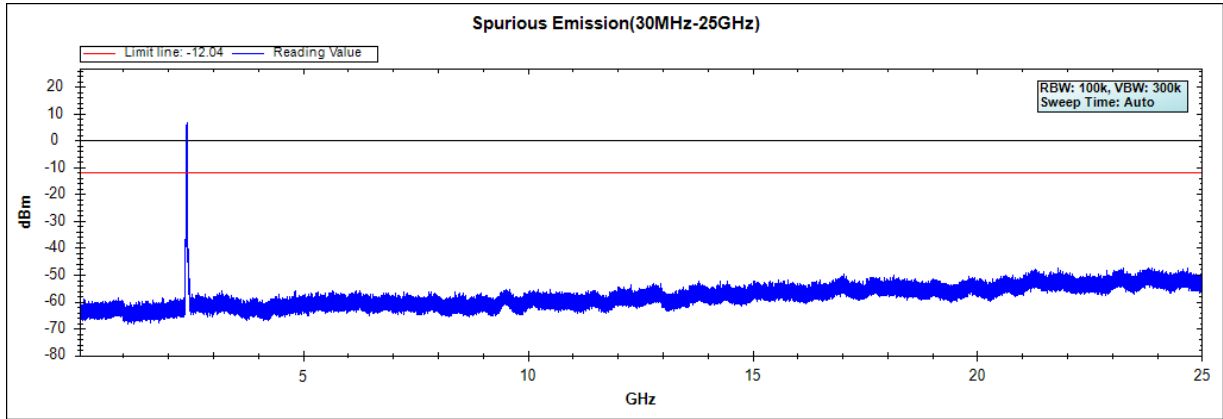

**Channel 06 (2437MHz) 30MHz -25GHz**

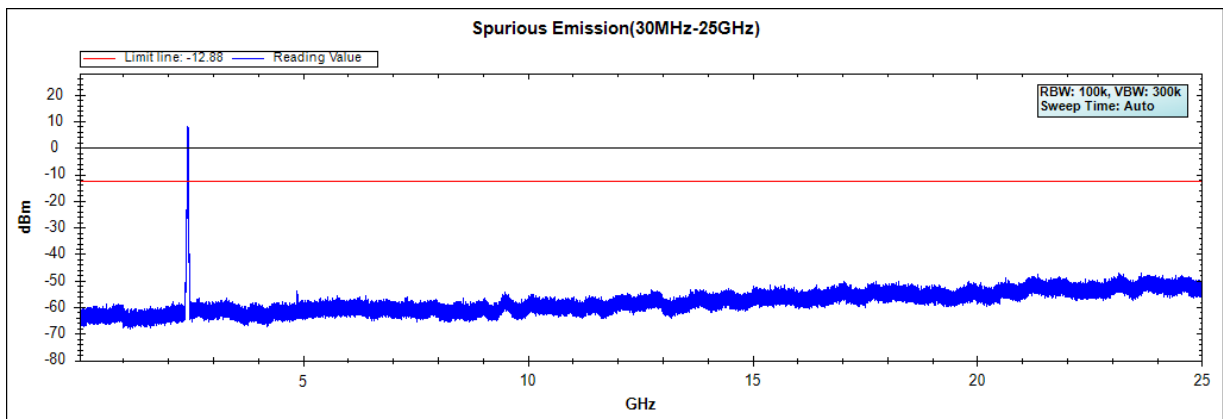

**Channel 11 (2462MHz) 30MHz -25GHz**

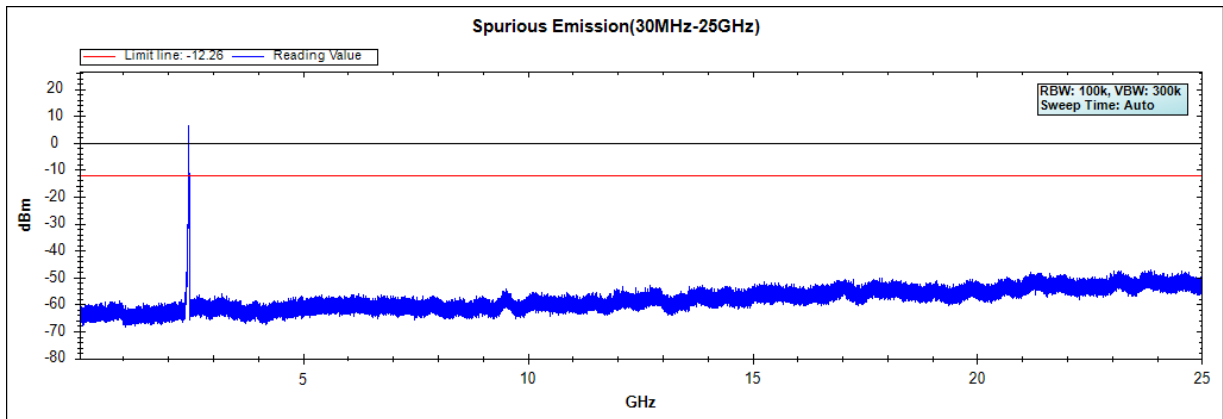

**Channel 12 (2467MHz) 30MHz -25GHz**

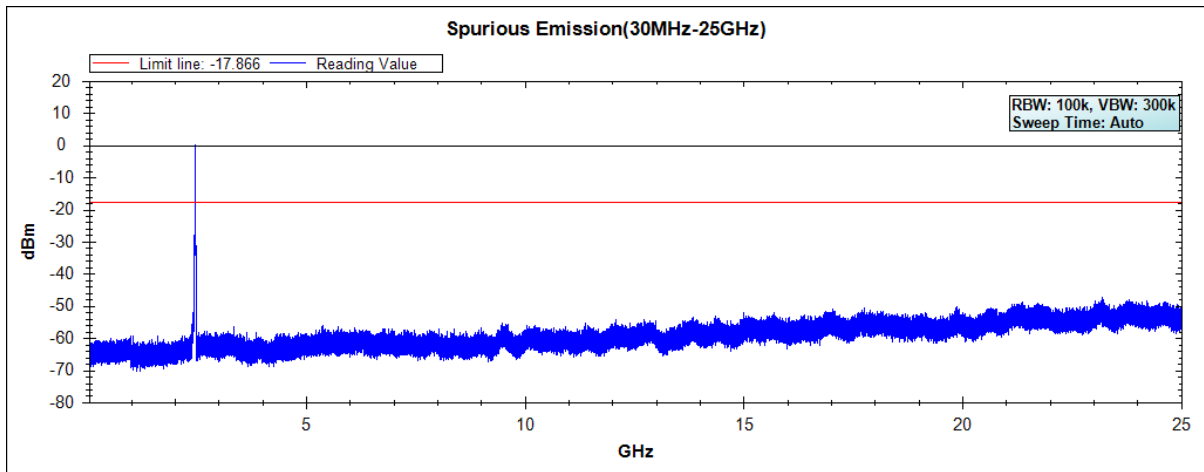

Note: The above test pattern is synthesized by multiple of the frequency range.

Product : Intel® Dual Band Wireless-AC 8260  
 Test Item : RF Antenna Conducted Spurious  
 Test Site : No.3 OATS  
 Test Mode : Mode 1 SISO A: Transmit - 802.11a 6Mbps

**Channel 149 (5745MHz) 30MHz -40GHz**

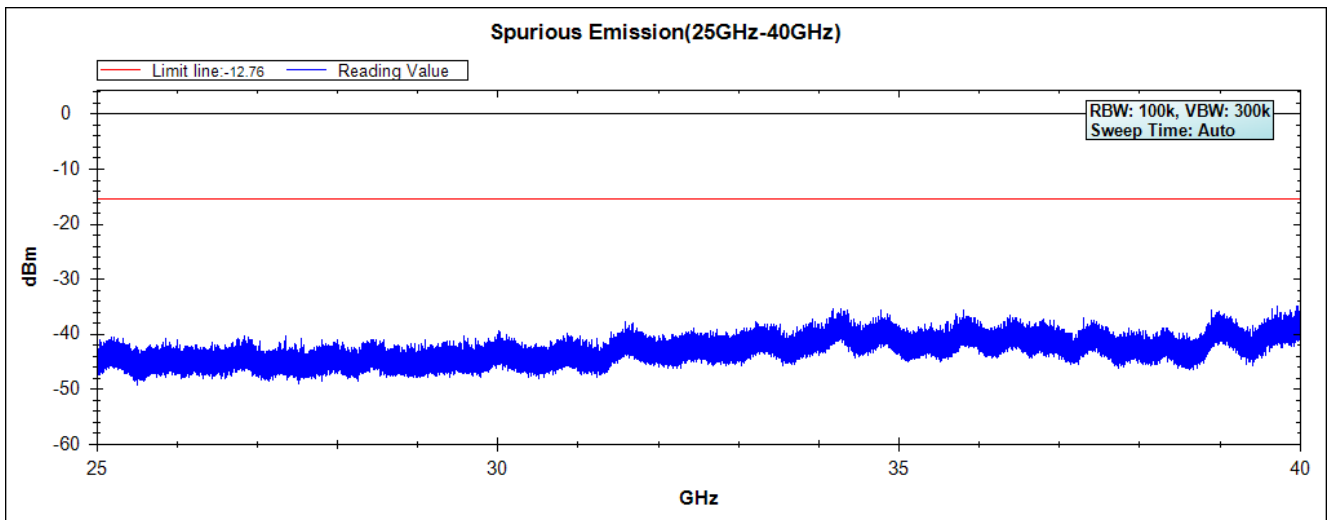
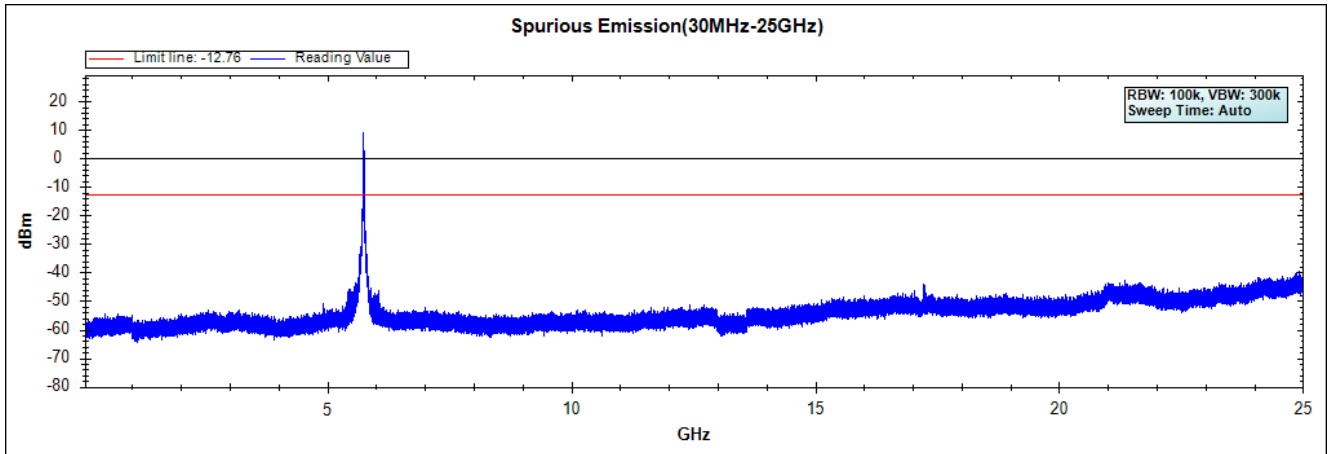

Note: The above test pattern is synthesized by multiple of the frequency range.



**Channel 157 (5785MHz) 30MHz -40GHz**

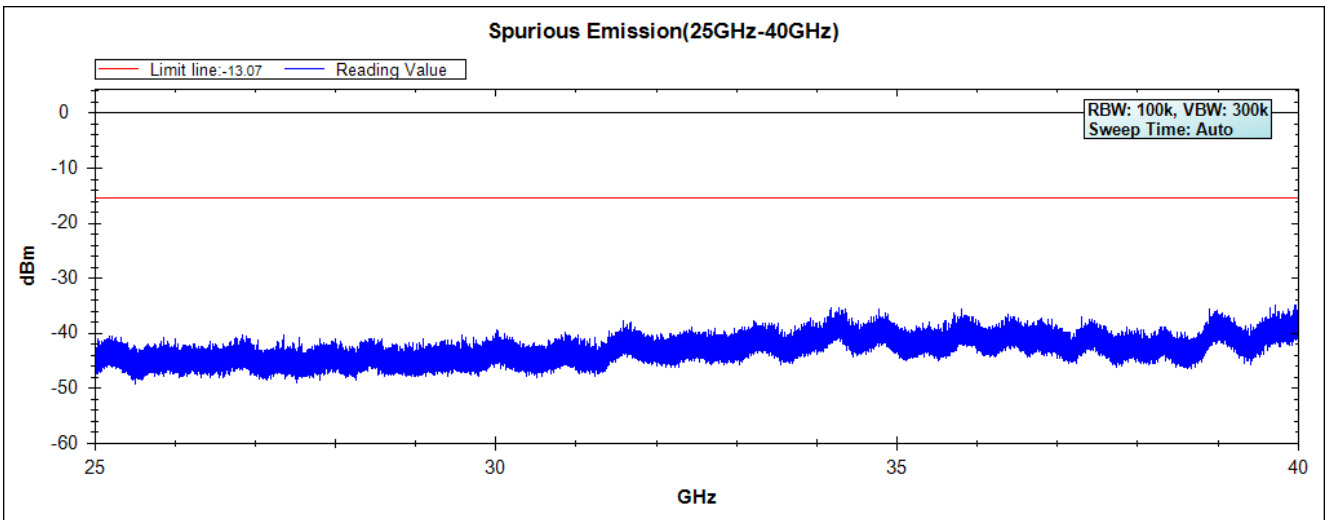
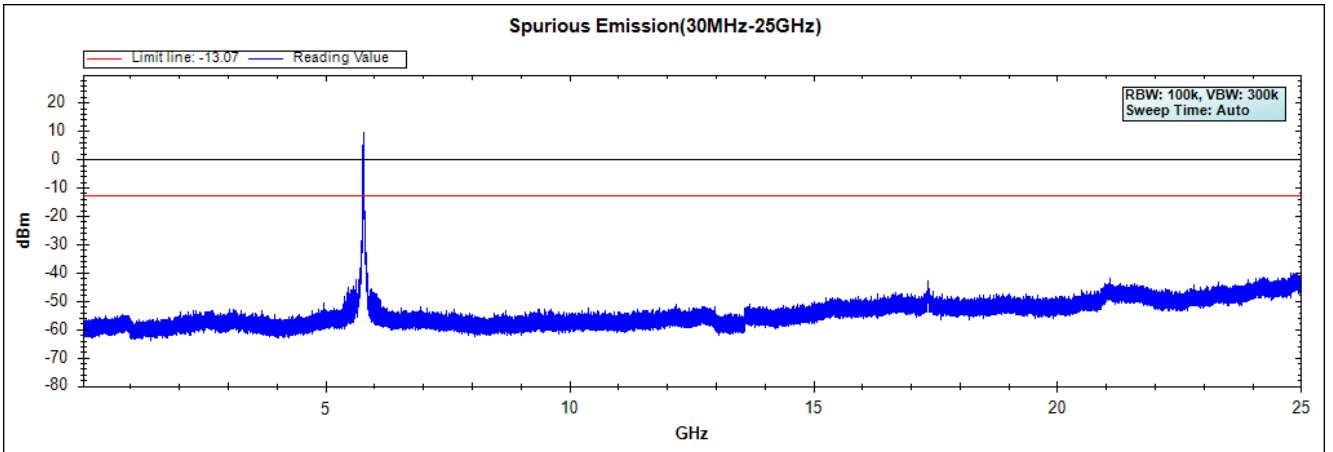

Note: The above test pattern is synthesized by multiple of the frequency range.

Channel 165 (5825MHz) 30MHz -40GHz

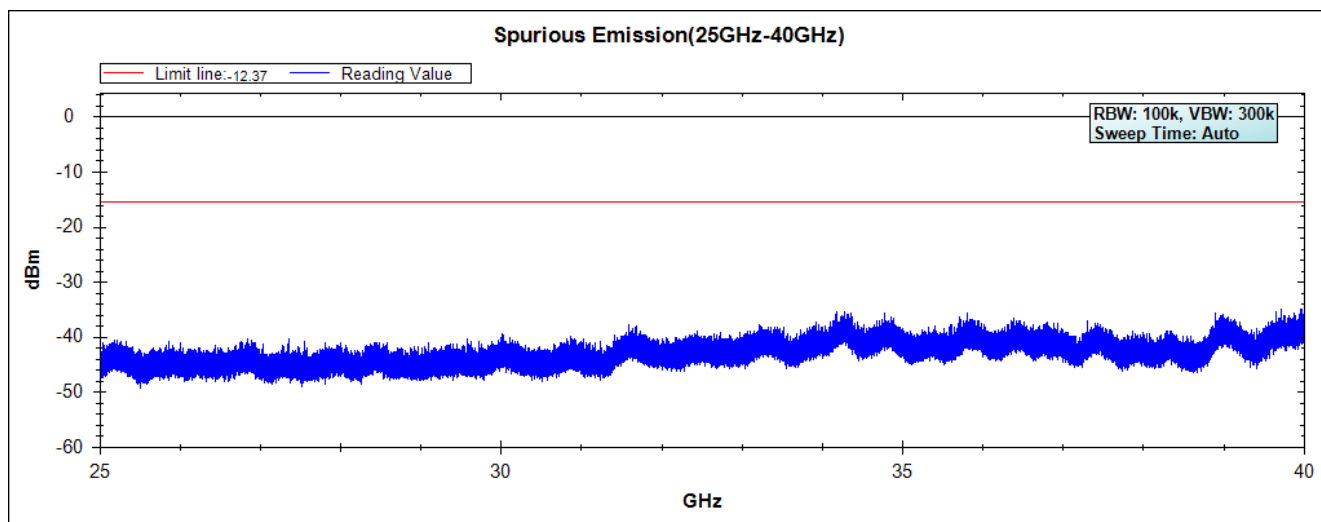
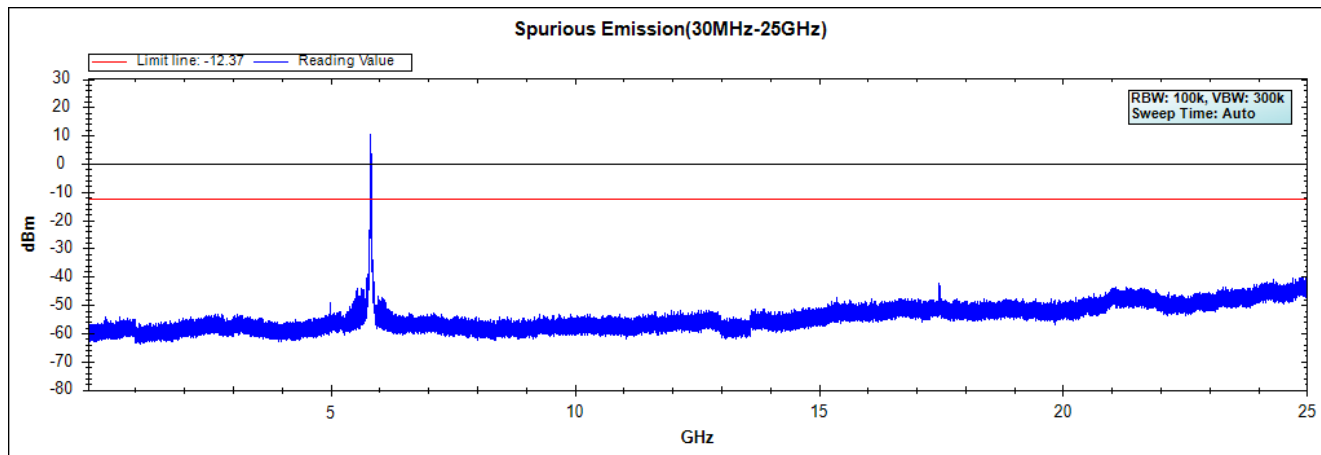

Note: The above test pattern is synthesized by multiple of the frequency range.

Product : Intel® Dual Band Wireless-AC 8260  
 Test Item : RF Antenna Conducted Spurious  
 Test Site : No.3 OATS  
 Test Mode : Mode 1 SISO A: Transmit - 802.11n-20BW\_7.2Mbps(2.4G Band)

**Channel 01 (2412MHz) 30MHz -25GHz**

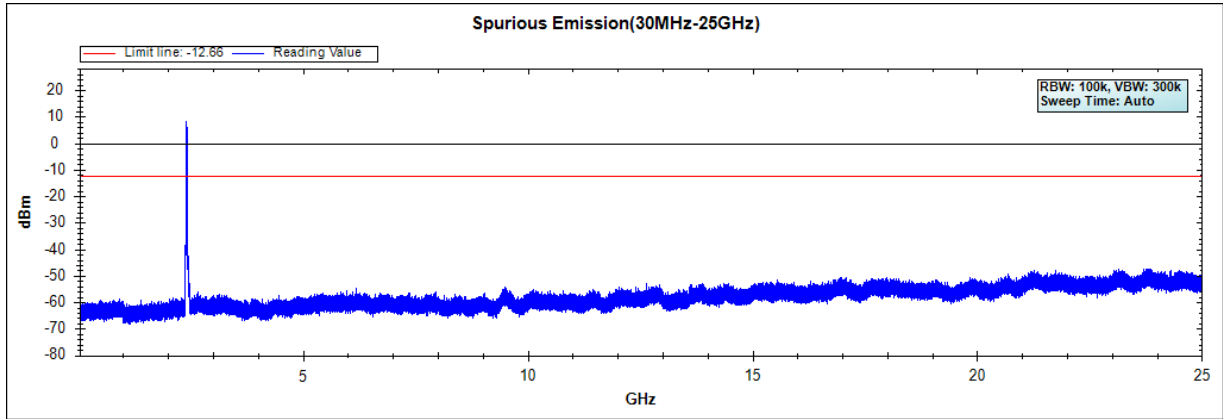

**Channel 06 (2437MHz) 30MHz -25GHz**

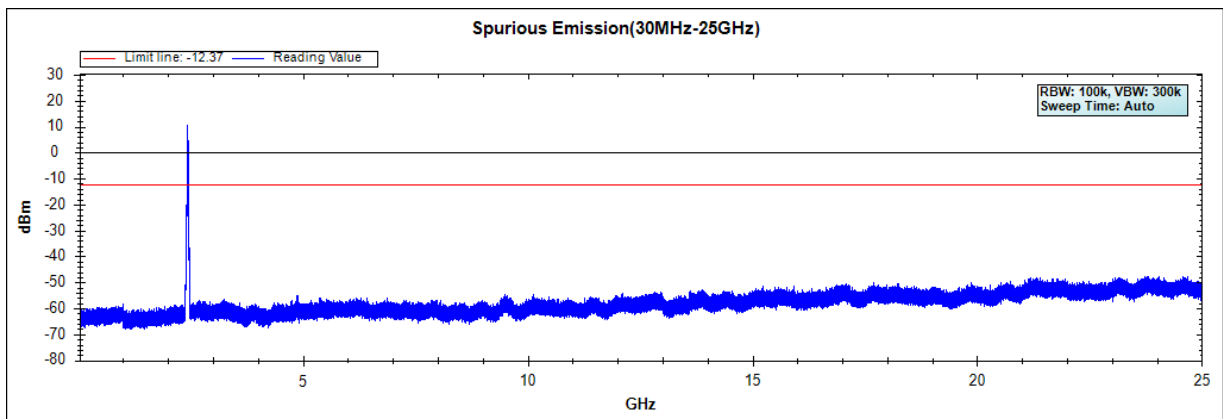

**Channel 11 (2462MHz) 30MHz -25GHz**

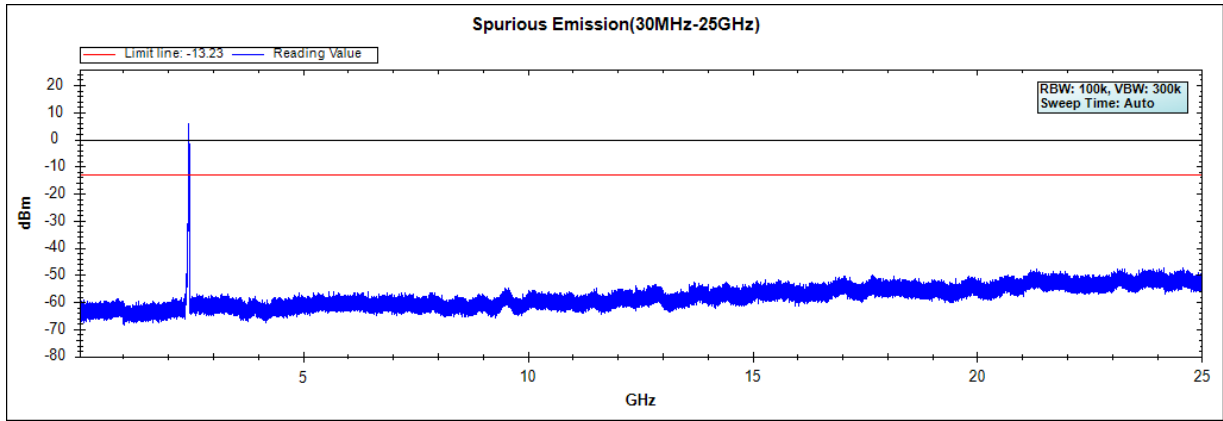

**Channel 12 (2467MHz) 30MHz -25GHz**

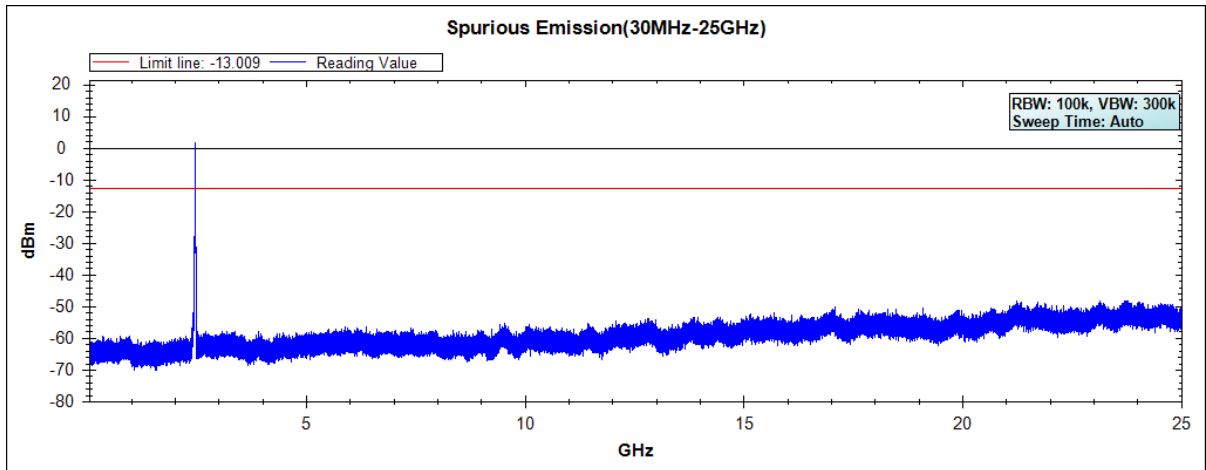

Note: The above test pattern is synthesized by multiple of the frequency range.

Product : Intel® Dual Band Wireless-AC 8260  
Test Item : RF Antenna Conducted Spurious  
Test Site : No.3 OATS  
Test Mode : Mode 1 SISO A: Transmit - 802.11n-40BW\_15Mbps(2.4G Band)

**Channel 03 (2422MHz) 30MHz -25GHz**

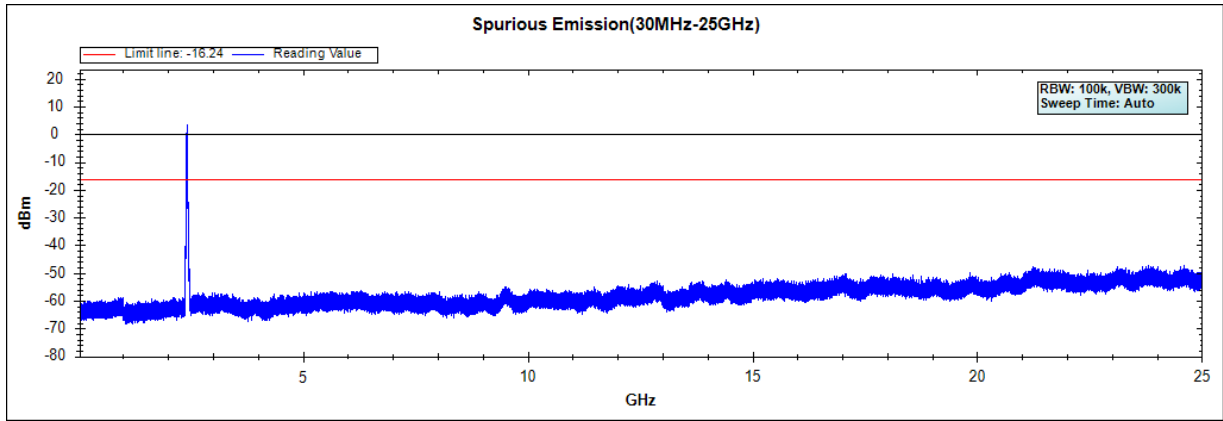

**Channel 06 (2437MHz) 30MHz -25GHz**

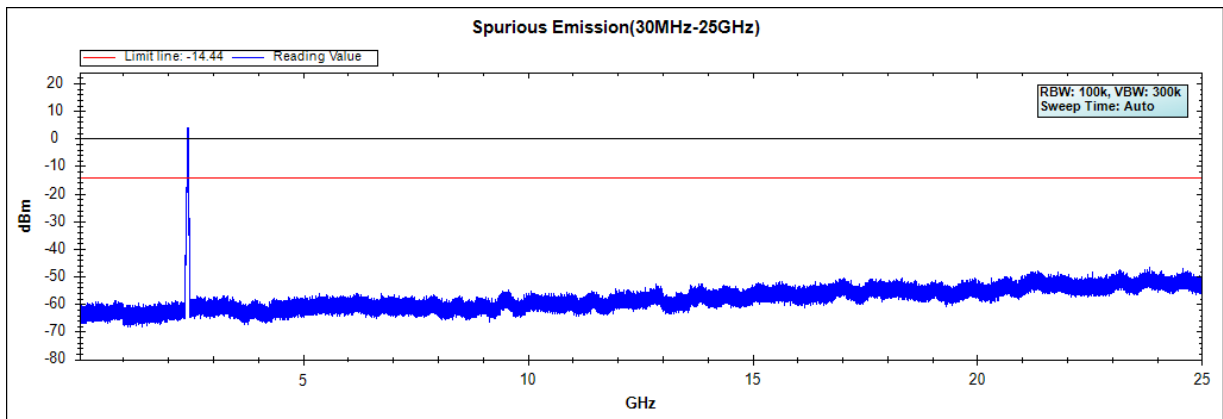

**Channel 09 (2452MHz) 30MHz -25GHz**

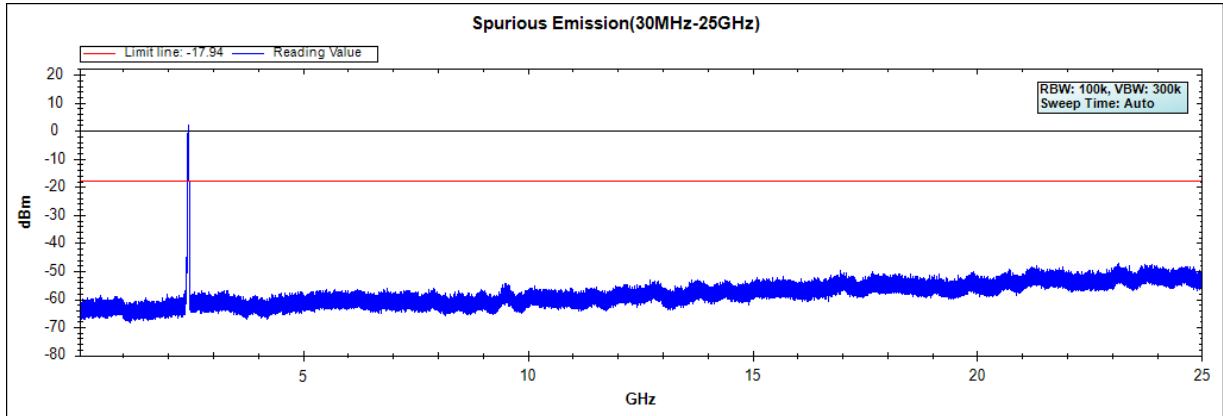

**Channel 10 (2457MHz) 30MHz -25GHz**

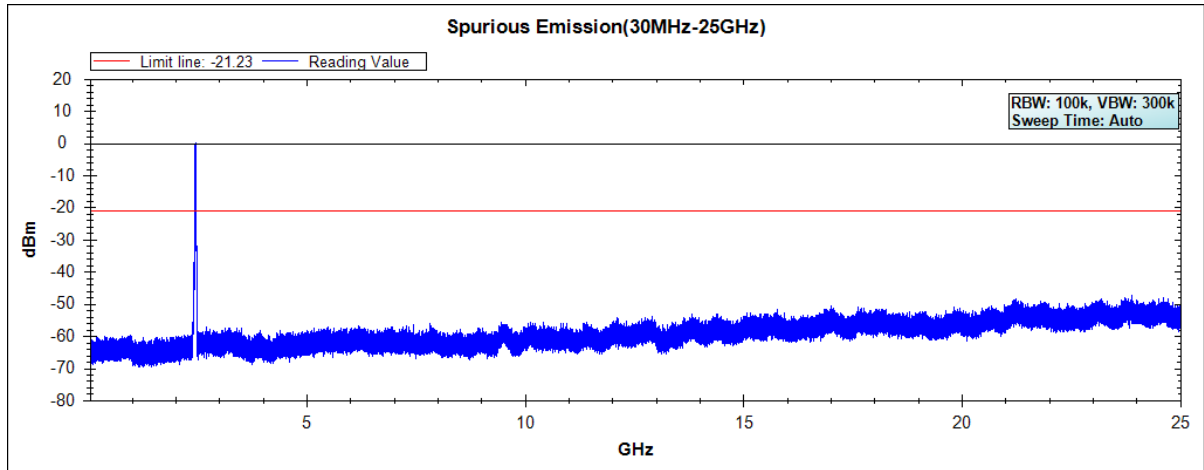

Note: The above test pattern is synthesized by multiple of the frequency range.

Product : Intel® Dual Band Wireless-AC 8260  
 Test Item : RF Antenna Conducted Spurious  
 Test Site : No.3 OATS  
 Test Mode : Mode 1 SISO A: Transmit - 802.11n-20BW\_7.2Mbps(5G Band)

**Channel 49 (5745MHz) 30MHz -40GHz**

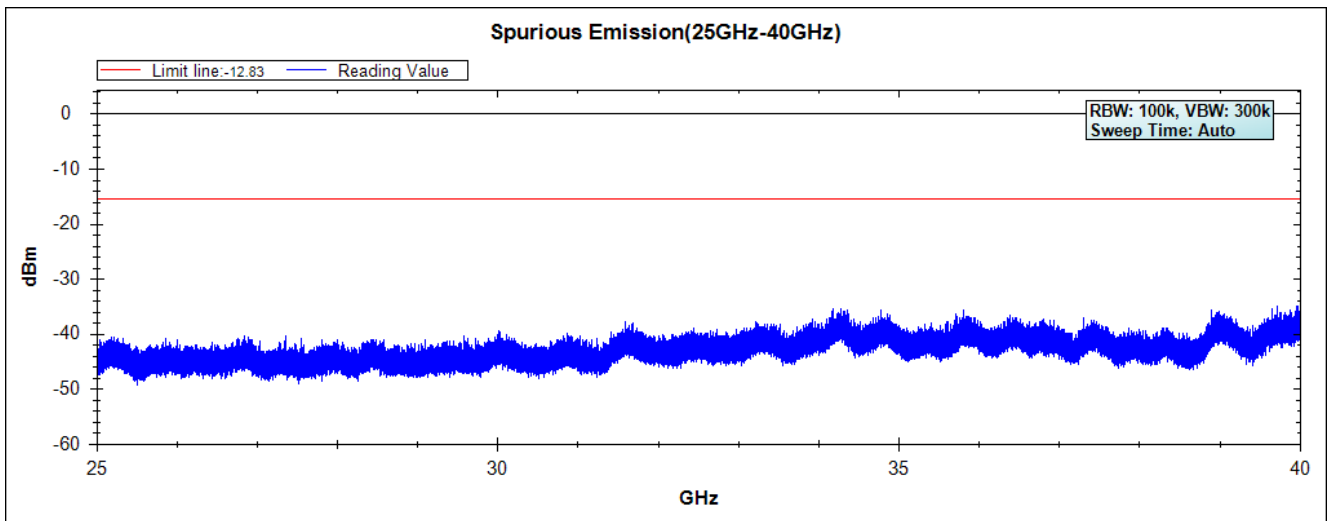
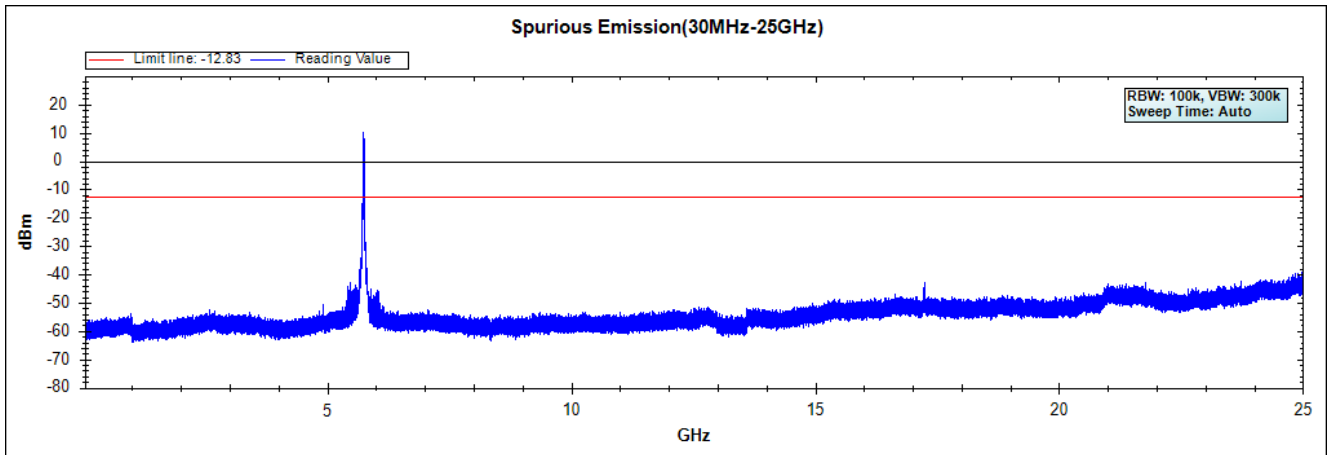

Note: The above test pattern is synthesized by multiple of the frequency range

Channel 157 (5785MHz) 30MHz -40GHz

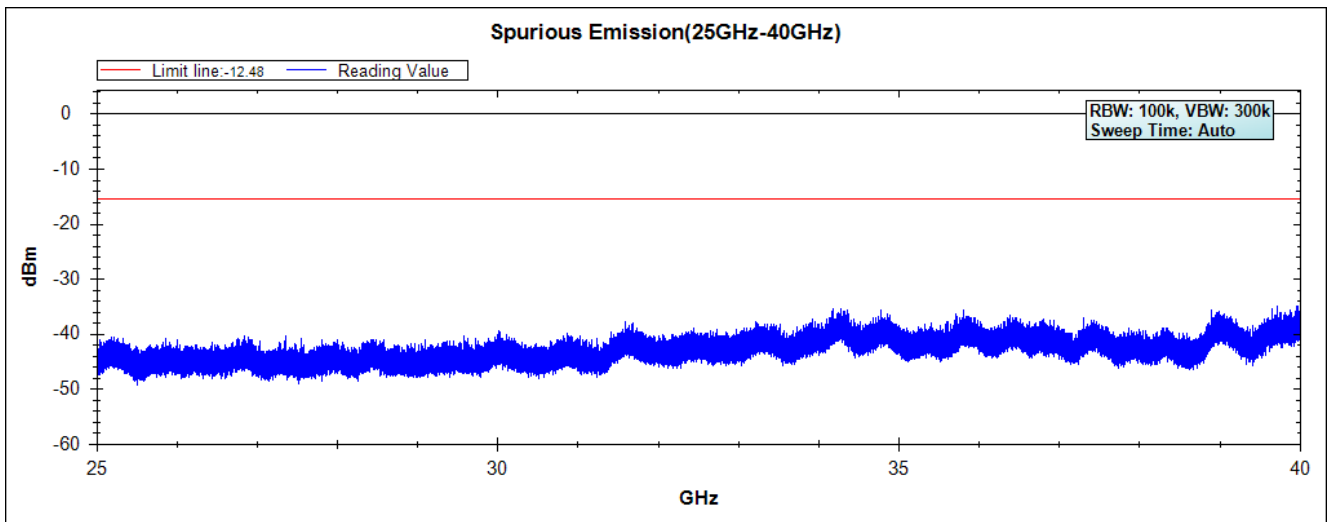
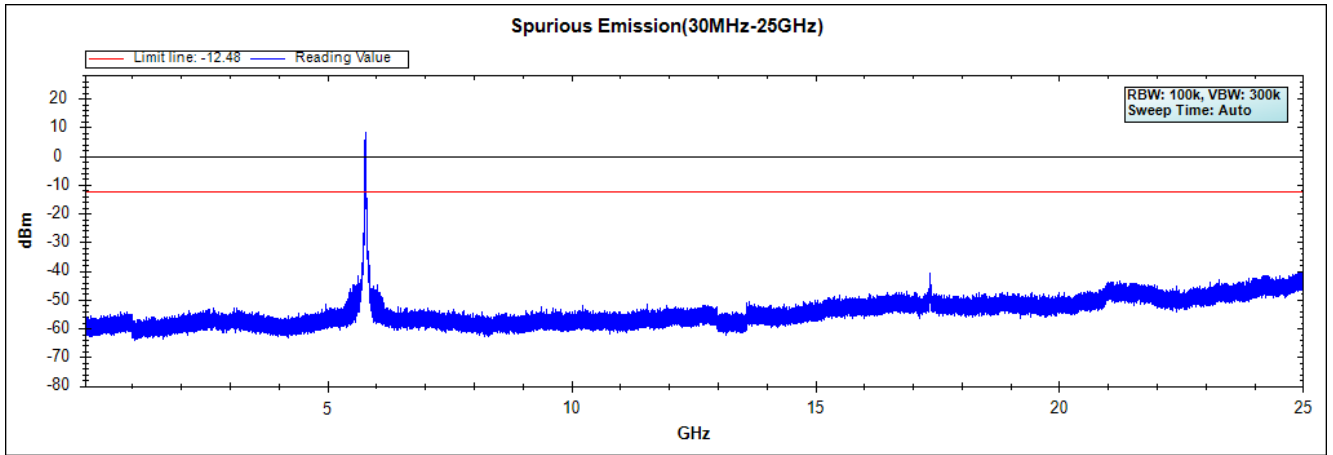

Note: The above test pattern is synthesized by multiple of the frequency range



**Channel 165 (5825MHz) 30MHz -40GHz**

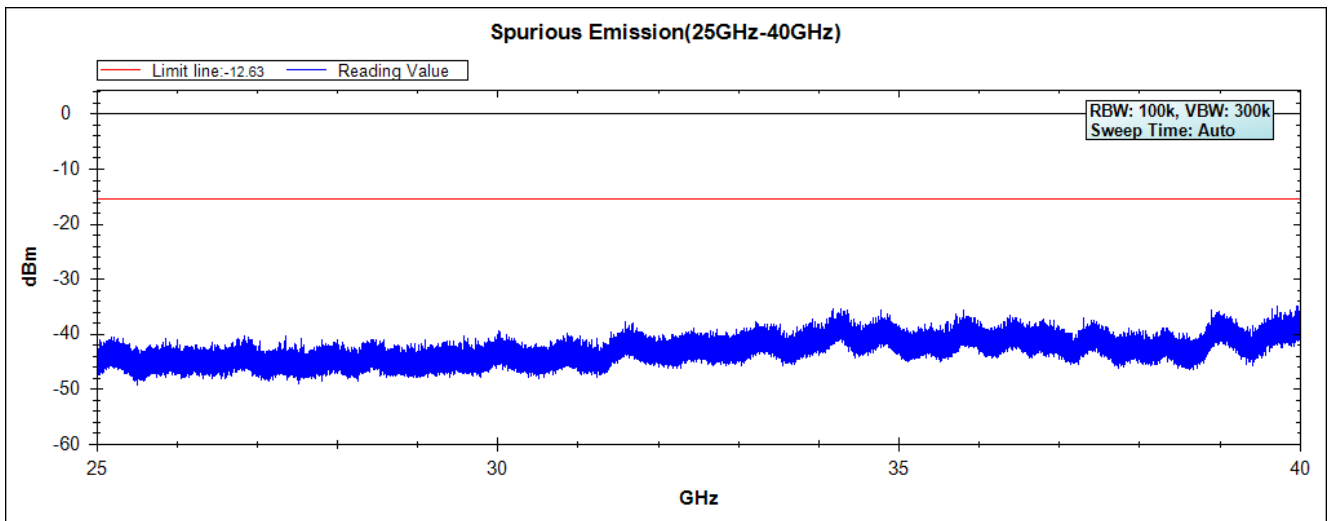
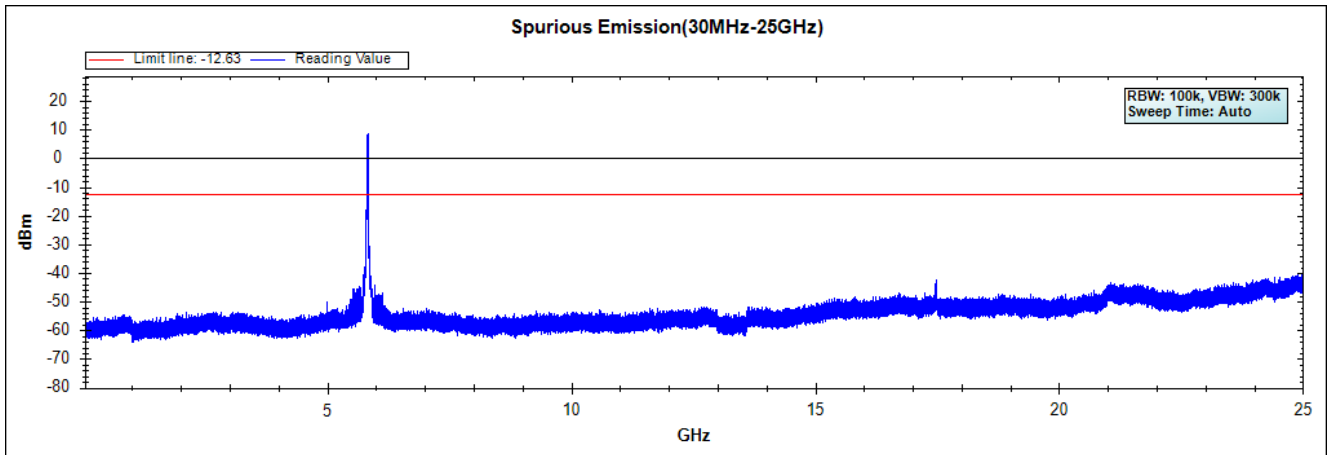

Note: The above test pattern is synthesized by multiple of the frequency range

Product : Intel® Dual Band Wireless-AC 8260  
Test Item : RF Antenna Conducted Spurious  
Test Site : No.3 OATS  
Test Mode : Mode 1 SISO A: Transmit - 802.11n-40BW\_15Mbps(5G Band)

**Channel 151 (5755MHz) 30MHz -40GHz**

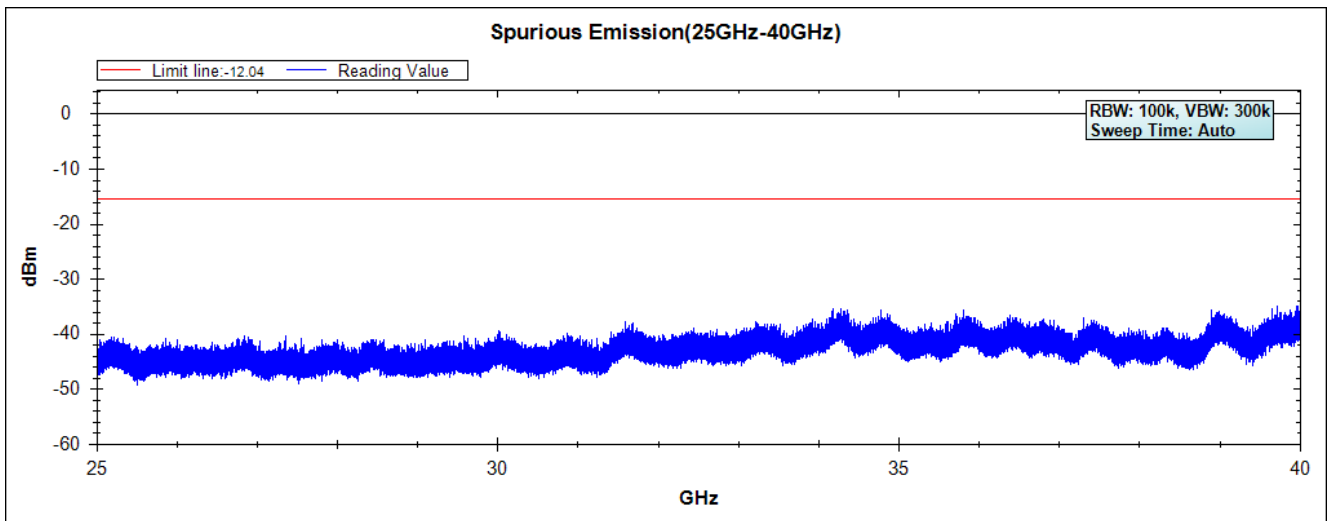
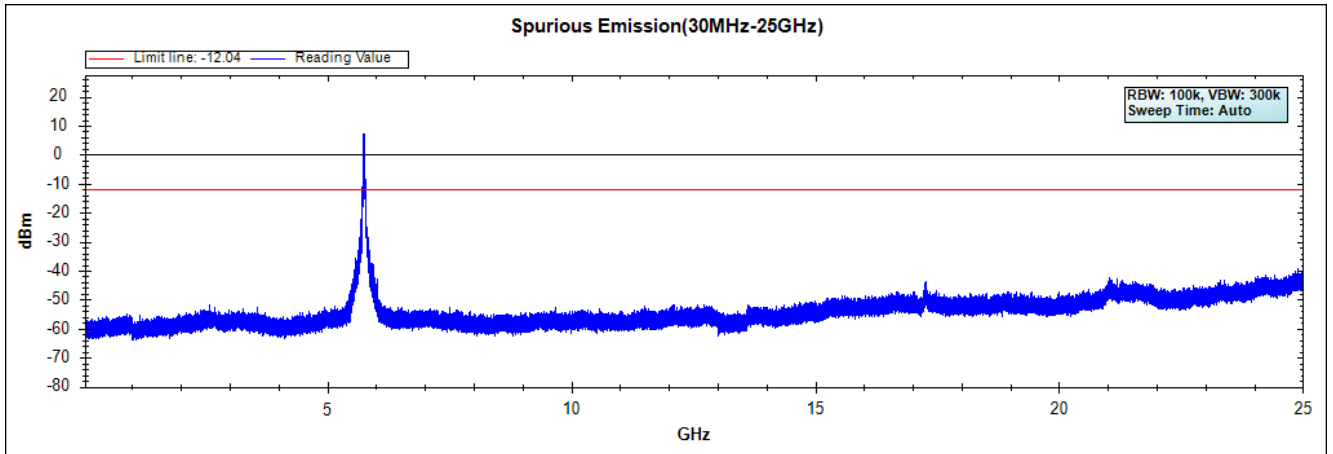

Note: The above test pattern is synthesized by multiple of the frequency range

Channel 159 (5795MHz) 30MHz -40GHz

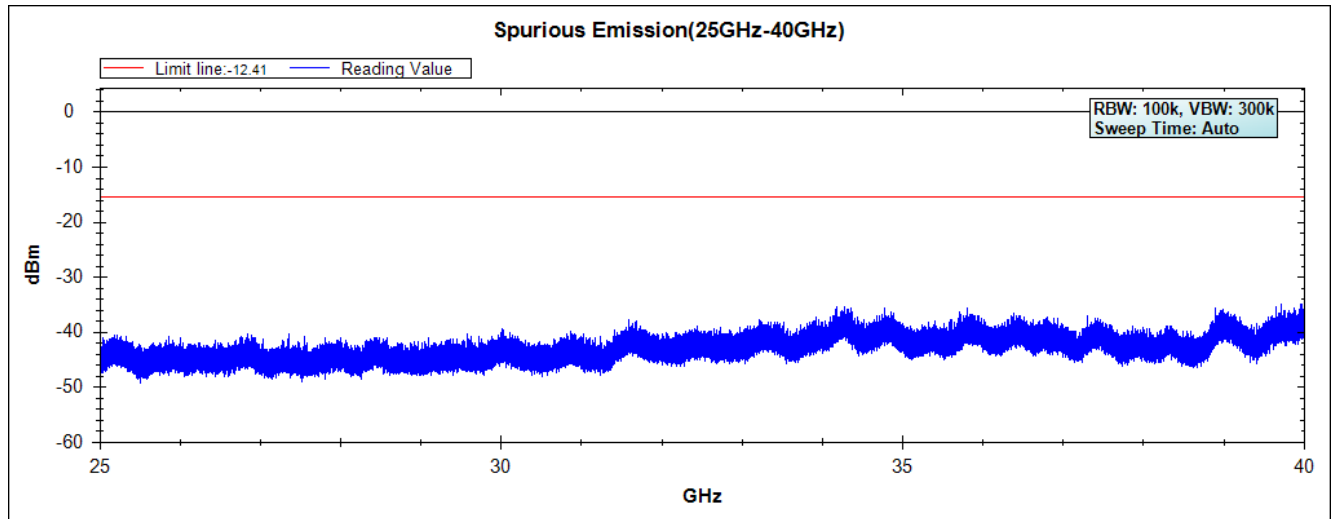
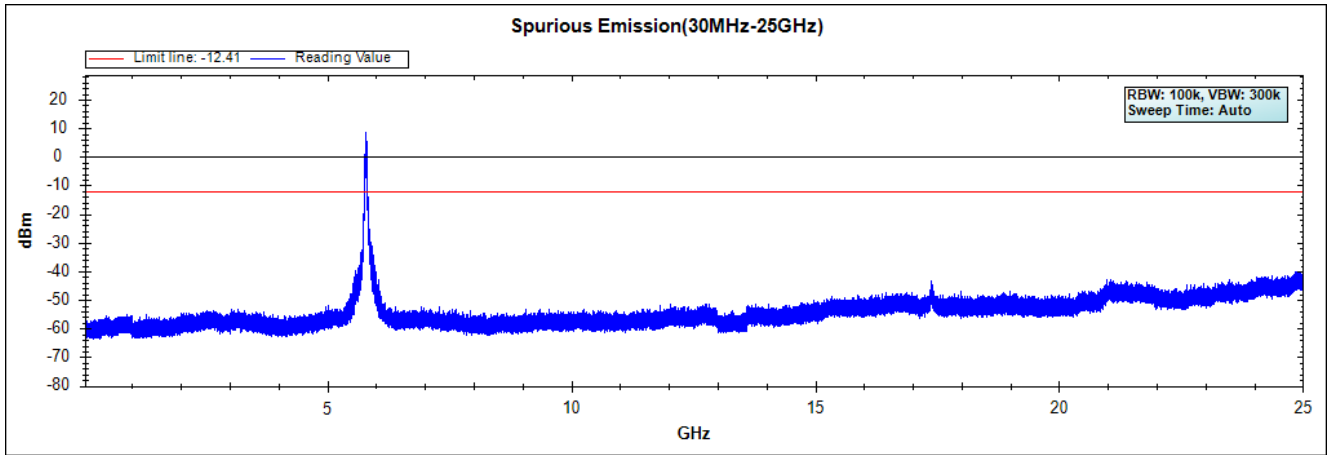

Note: The above test pattern is synthesized by multiple of the frequency range

Product : Intel® Dual Band Wireless-AC 8260  
Test Item : RF Antenna Conducted Spurious  
Test Site : No.3 OATS  
Test Mode : Mode 1 SISO A: Transmit - 802.11ac-80BW\_32.5Mbps(5G Band)

**Channel 155 (5775MHz) 30MHz -40GHz**

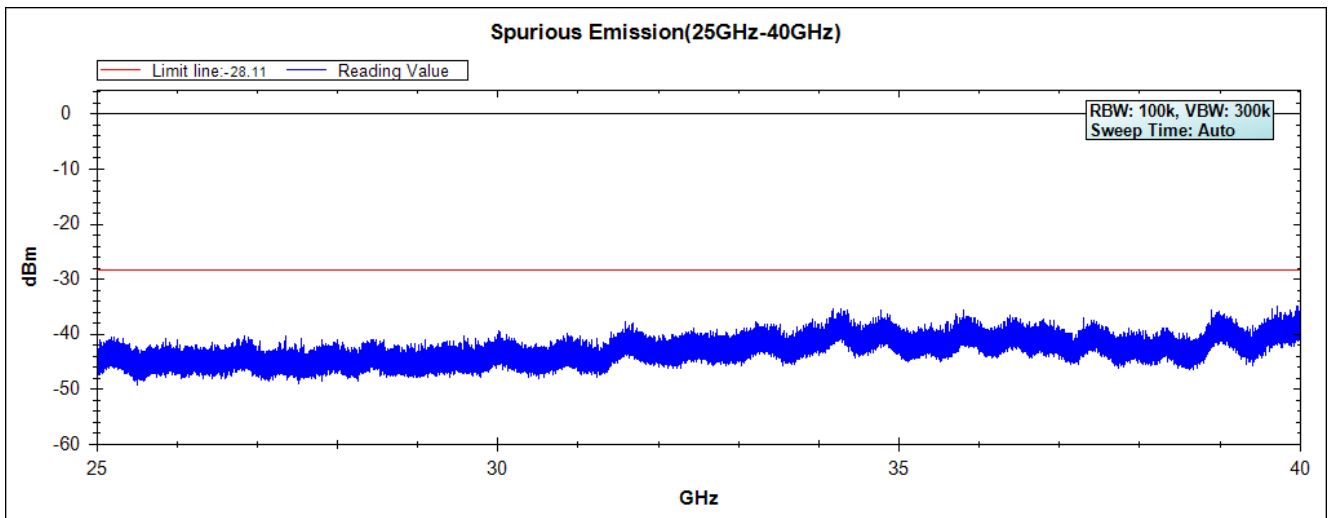
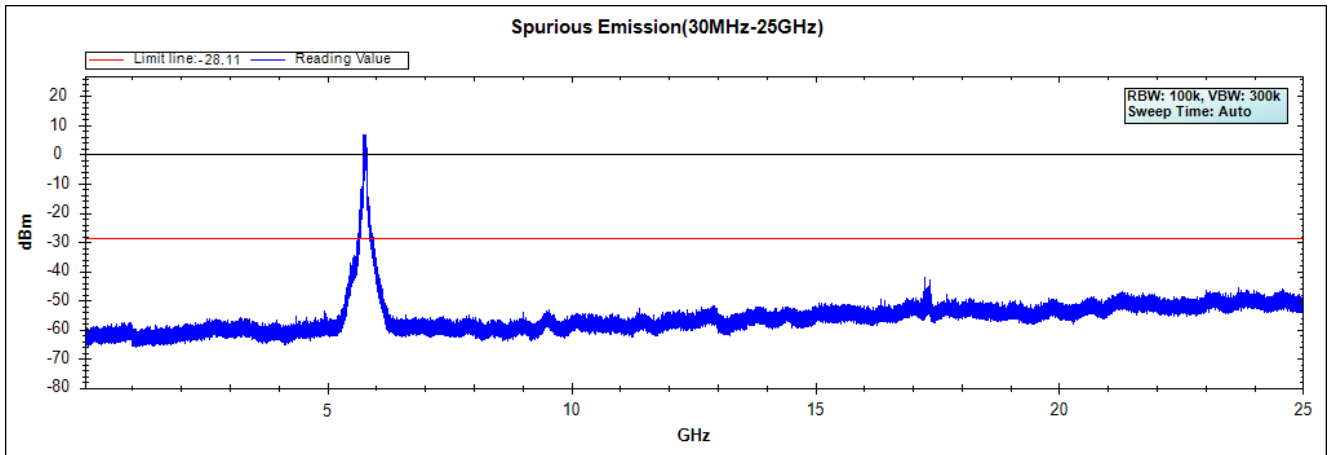

Note: The above test pattern is synthesized by multiple of the frequency range

Product : Intel® Dual Band Wireless-AC 8260  
Test Item : RF antenna conducted test  
Test Site : No.3 OATS  
Test Mode : Mode 2 SISO B: Transmit (802.11b 1Mbps)

**Channel 01 (2412MHz) 30MHz-25GHz**

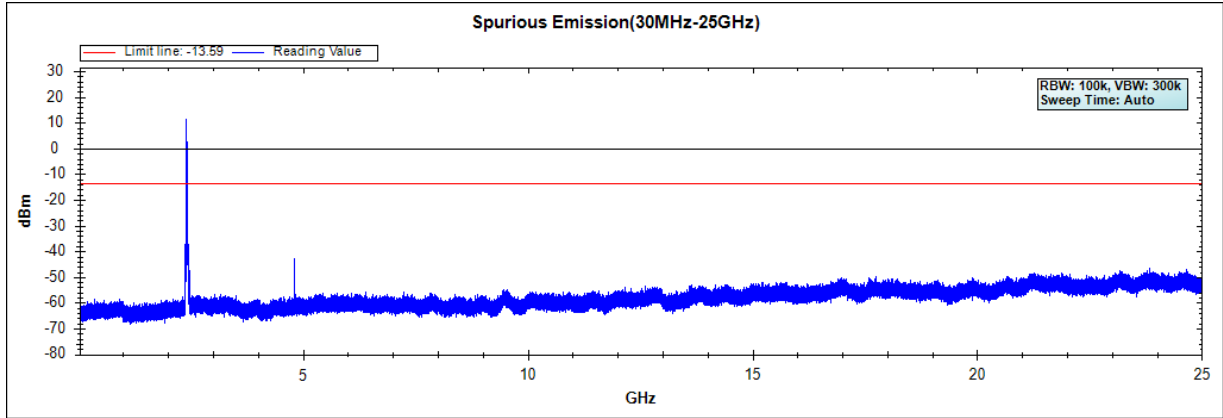

**Channel 06 (2437MHz) 30MHz -25GHz**

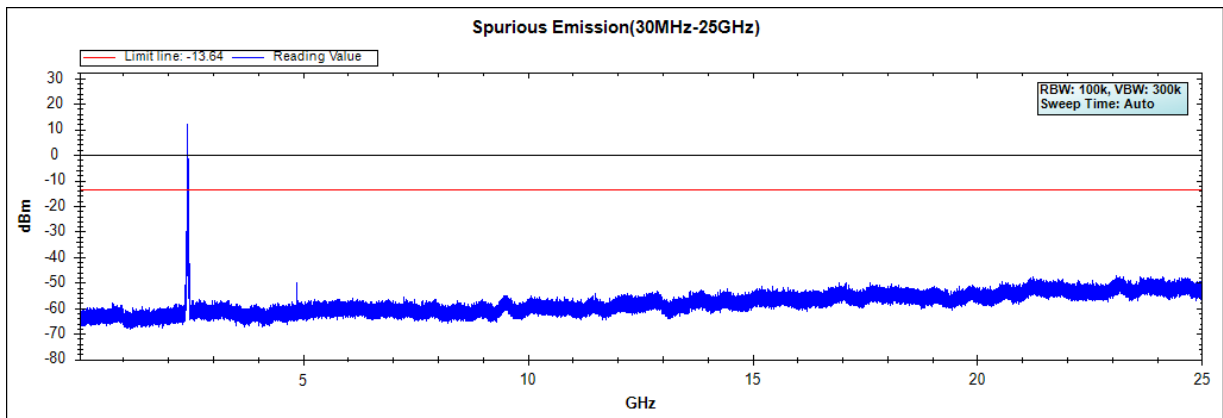

**Channel 11 (2462MHz) 30MHz -25GHz**

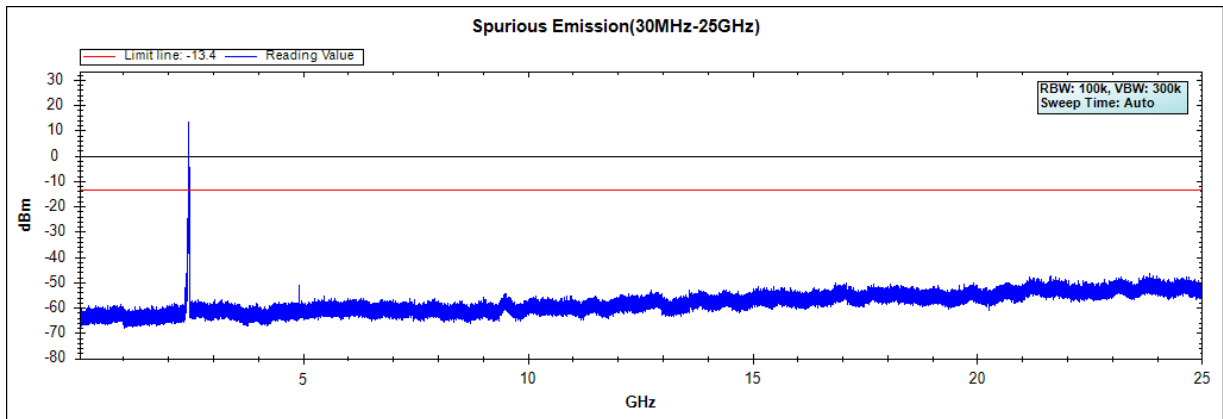

**Channel 12 (2467MHz) 30MHz -25GHz**

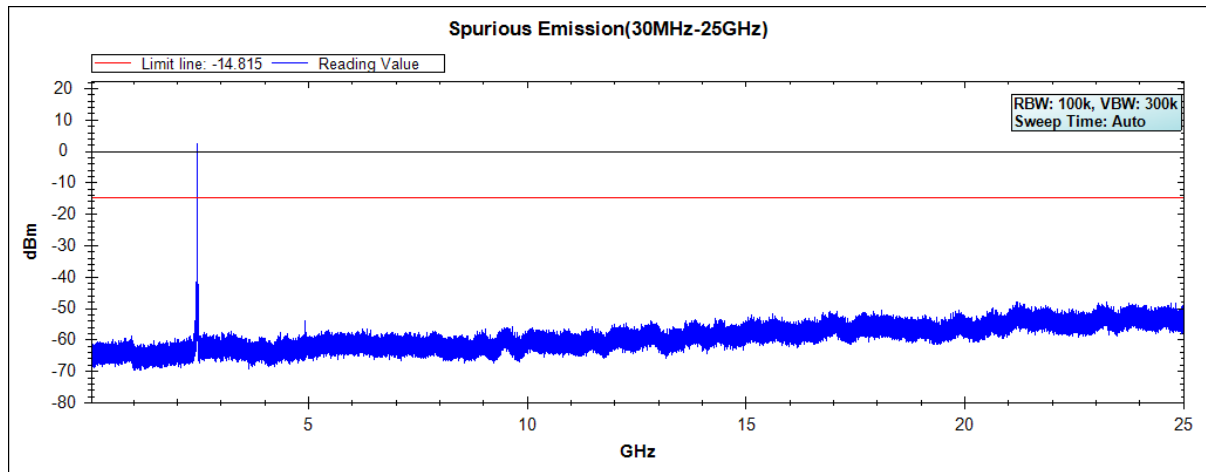

Note: The above test pattern is synthesized by multiple of the frequency range.

Product : Intel® Dual Band Wireless-AC 8260  
Test Item : RF Antenna Conducted Spurious  
Test Site : No.3 OATS  
Test Mode : Mode 2 SISO B: Transmit (802.11g 6Mbps)

**Channel 01 (2412MHz) 30MHz -25GHz**

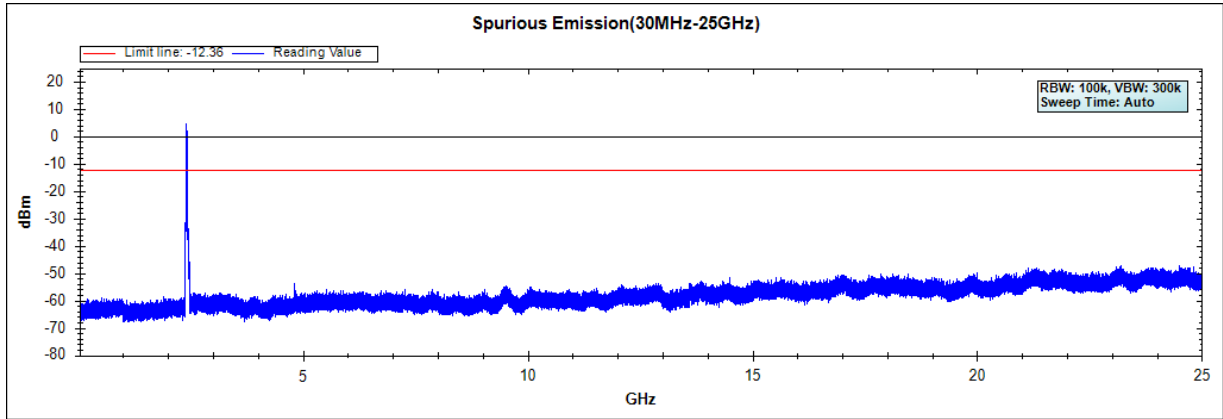

**Channel 06 (2437MHz) 30MHz -25GHz**

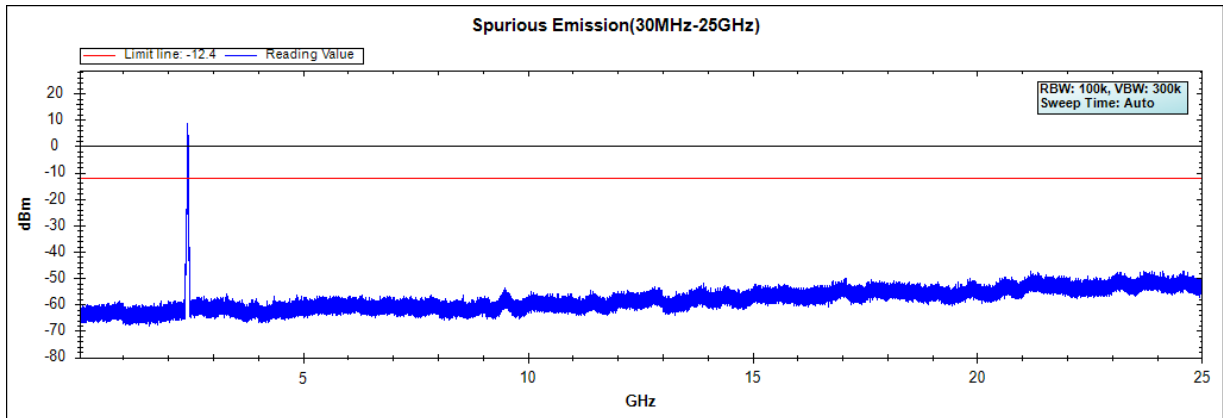

**Channel 11 (2462MHz) 30MHz -25GHz**

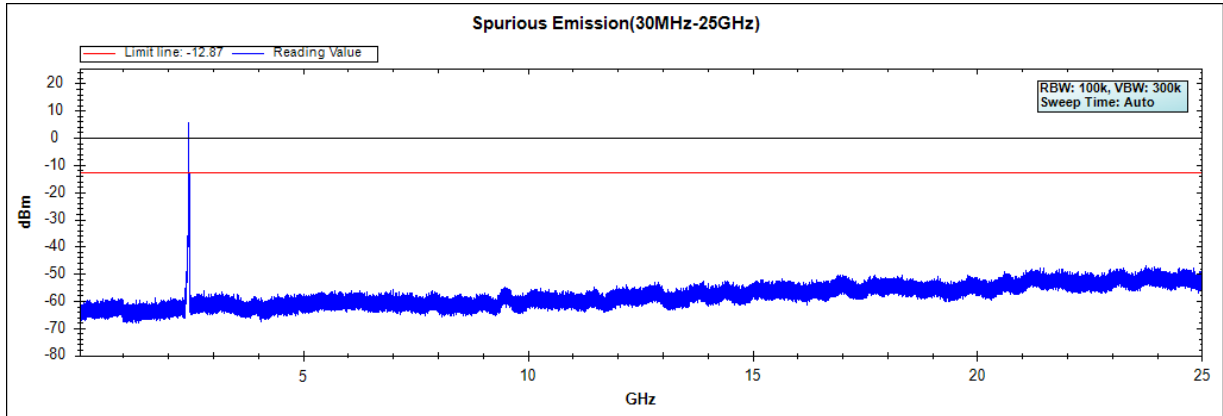

**Channel 12 (2467MHz) 30MHz -25GHz**

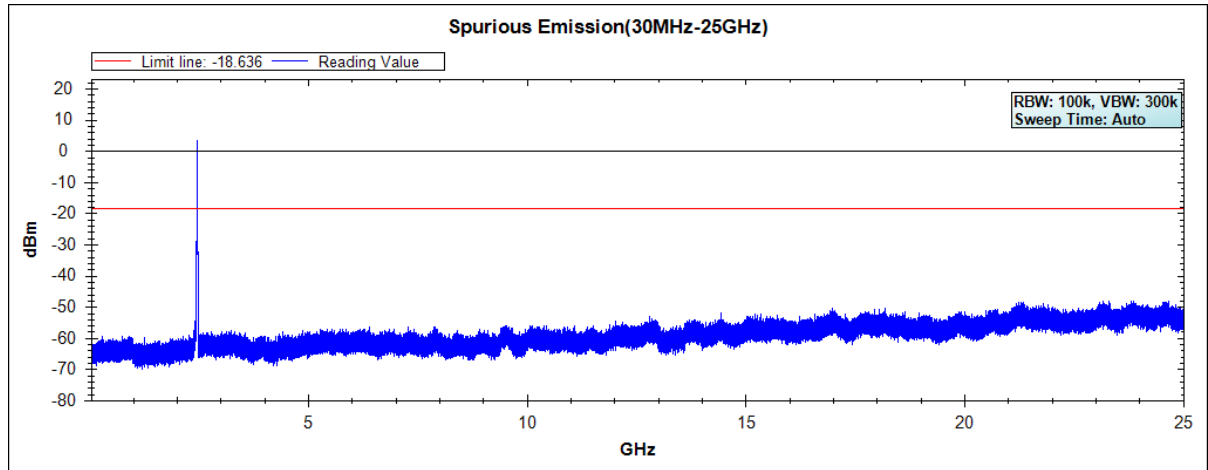

Note: The above test pattern is synthesized by multiple of the frequency range.



Product : Intel® Dual Band Wireless-AC 8260  
 Test Item : RF Antenna Conducted Spurious  
 Test Site : No.3 OATS  
 Test Mode : Mode 2 SISO B: Transmit - 802.11a 6Mbps

**Channel 149 (5745MHz) 30MHz -40GHz**

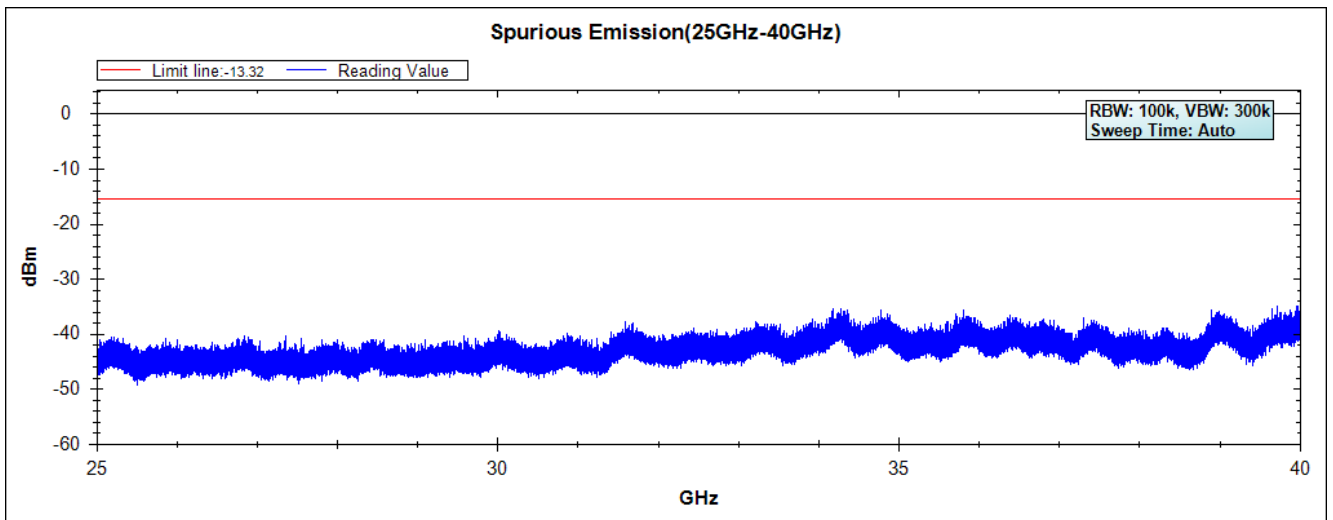
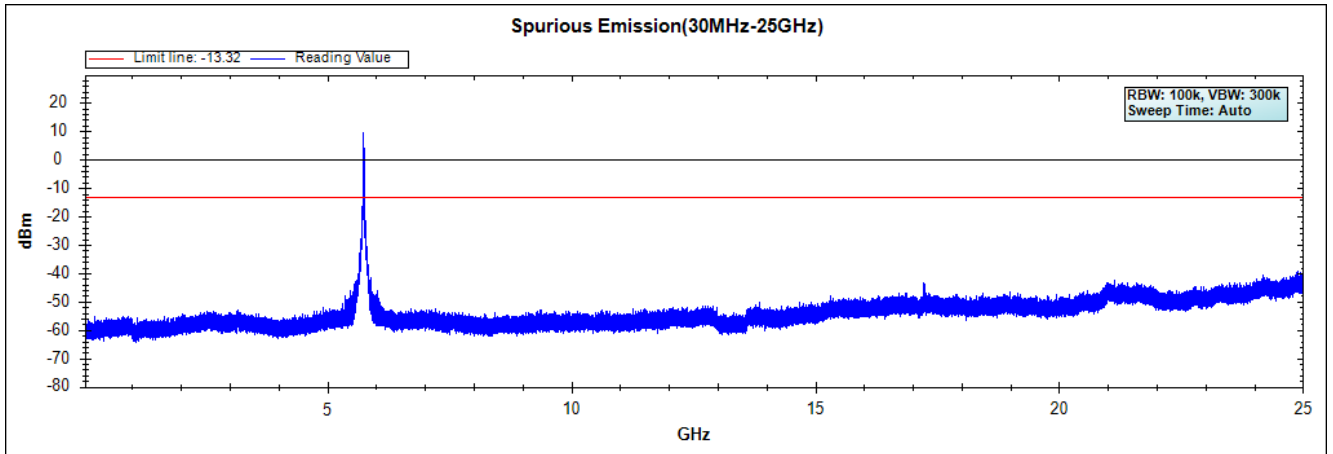

Note: The above test pattern is synthesized by multiple of the frequency range.

**Channel 157 (5785MHz) 30MHz -40GHz**

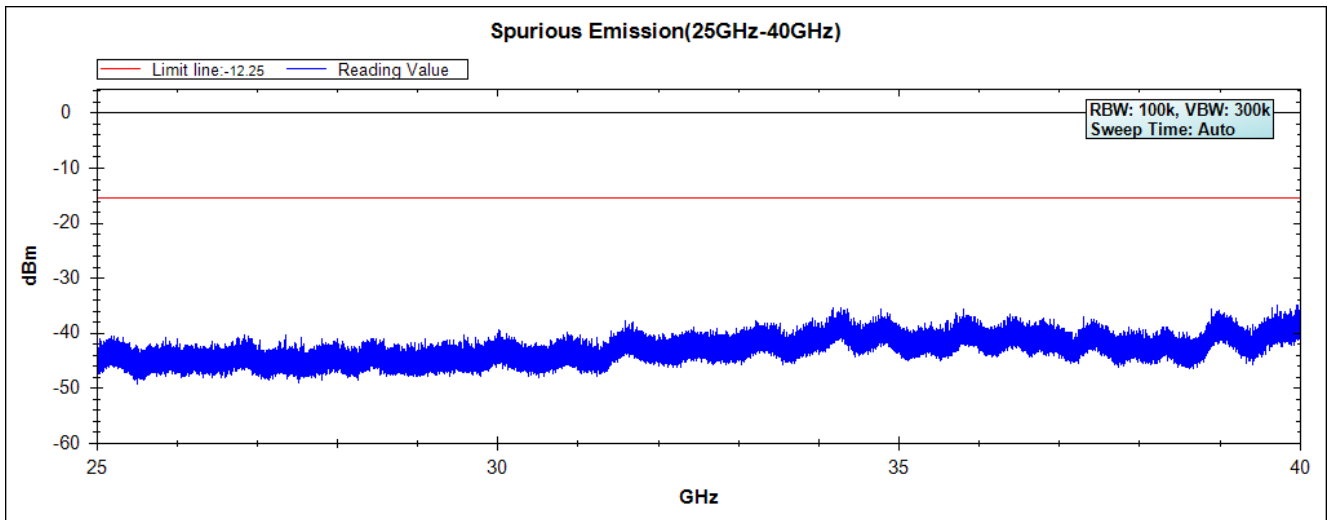
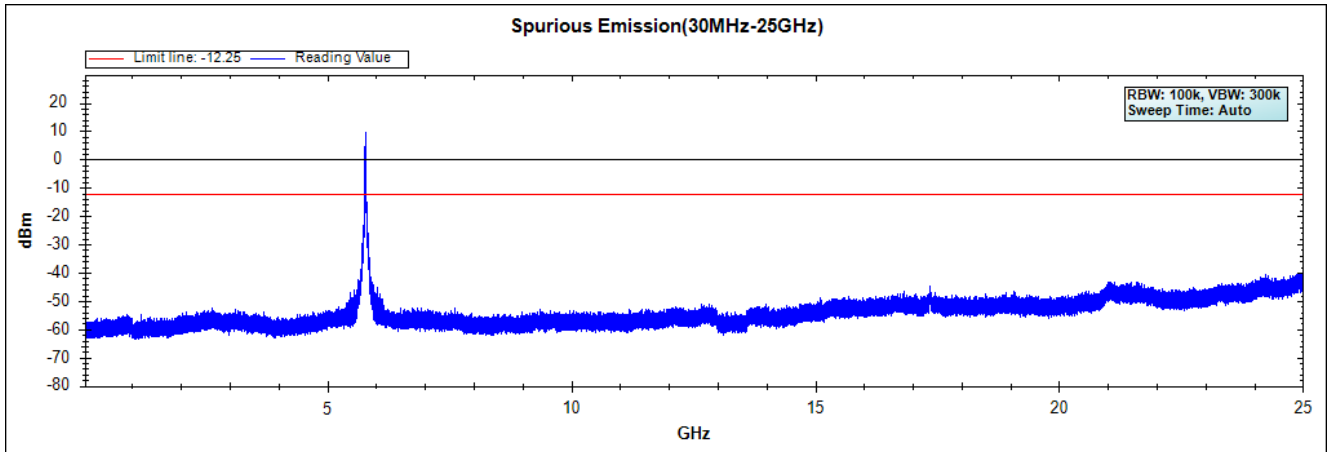

Note: The above test pattern is synthesized by multiple of the frequency range.

Channel 165 (5825MHz) 30MHz -40GHz

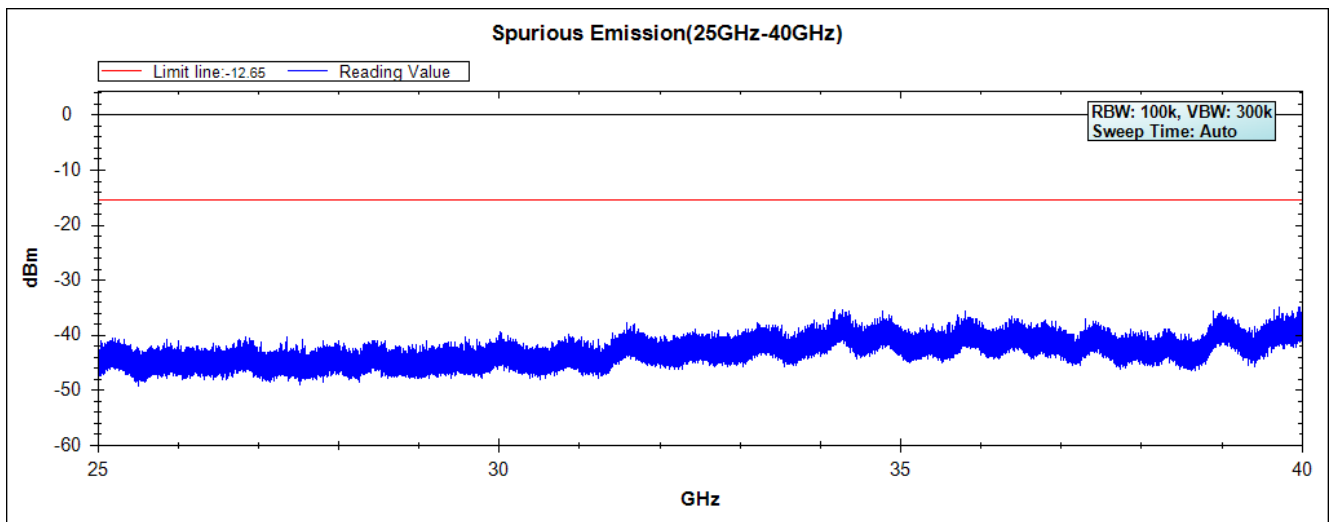
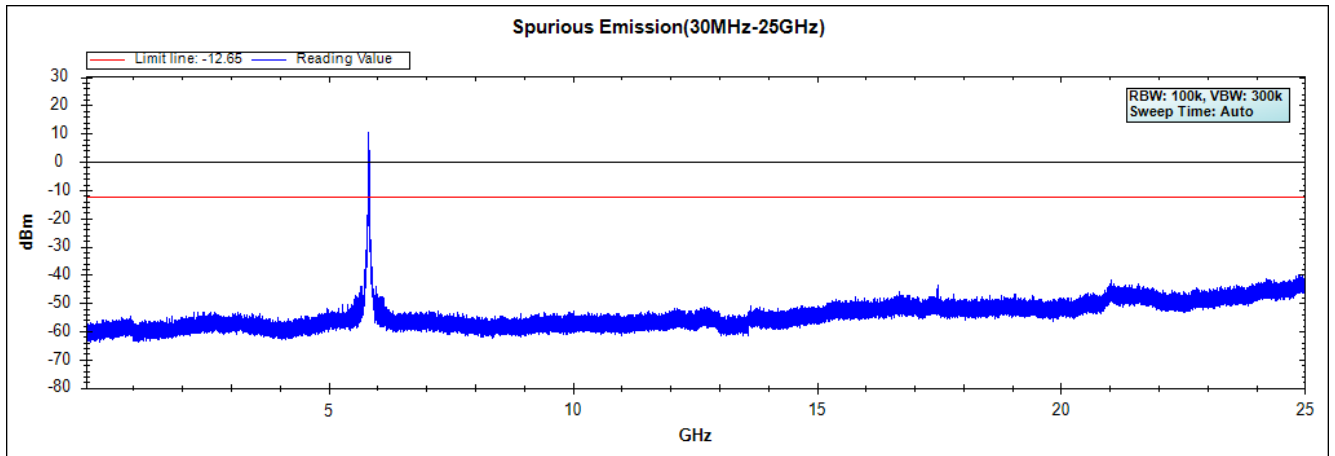

Note: The above test pattern is synthesized by multiple of the frequency range.

Product : Intel® Dual Band Wireless-AC 8260  
Test Item : RF Antenna Conducted Spurious  
Test Site : No.3 OATS  
Test Mode : Mode 2 SISO B: Transmit - 802.11n-20BW\_7.2Mbps(2.4G Band)

**Channel 01 (2412MHz) 30MHz -25GHz**

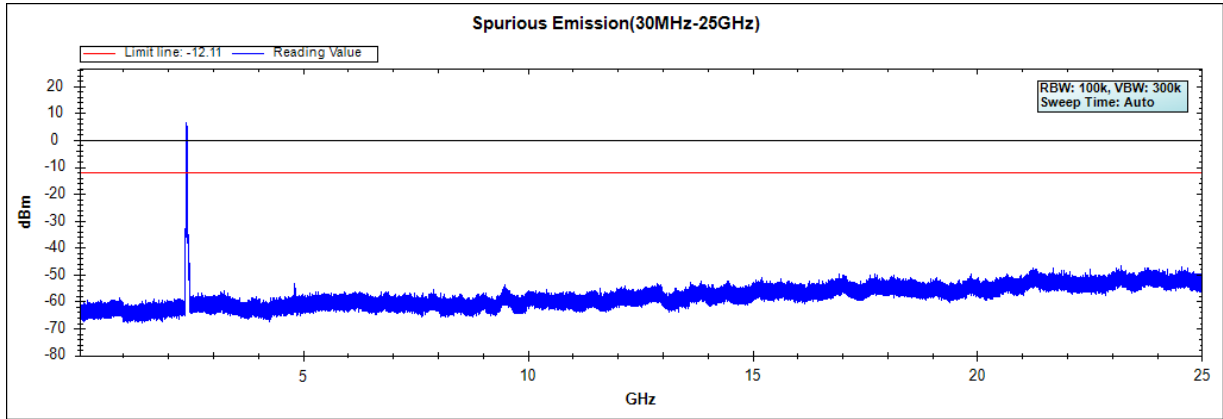

**Channel 06 (2437MHz) 30MHz -25GHz**

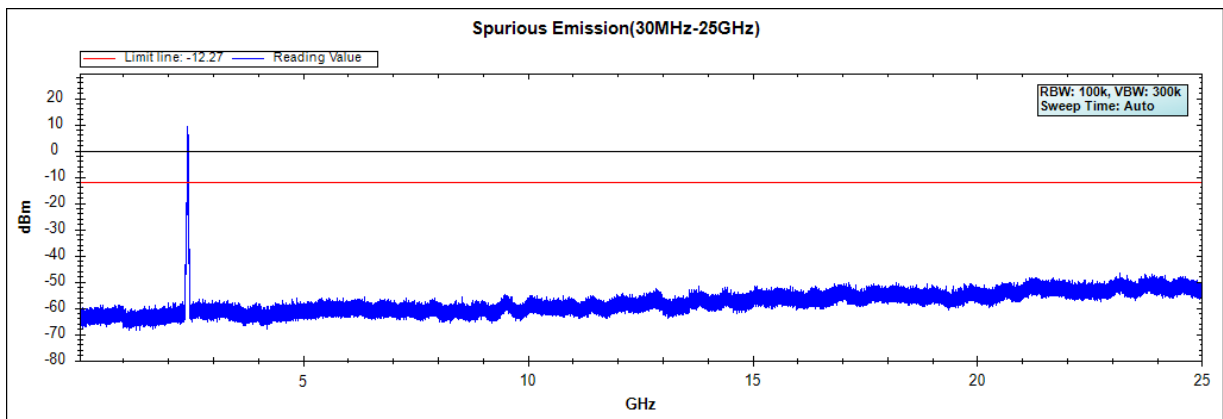

**Channel 11 (2462MHz) 30MHz -25GHz**

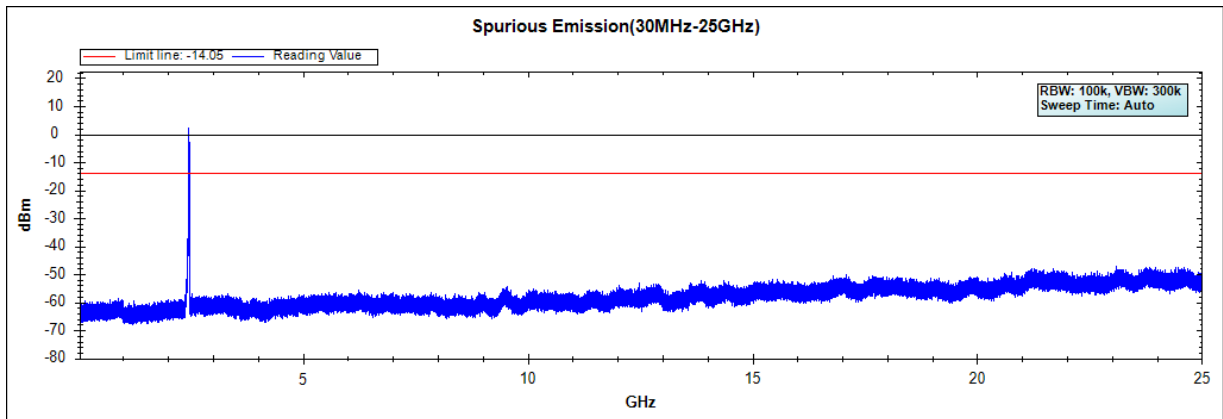

**Channel 12 (2467MHz) 30MHz -25GHz**

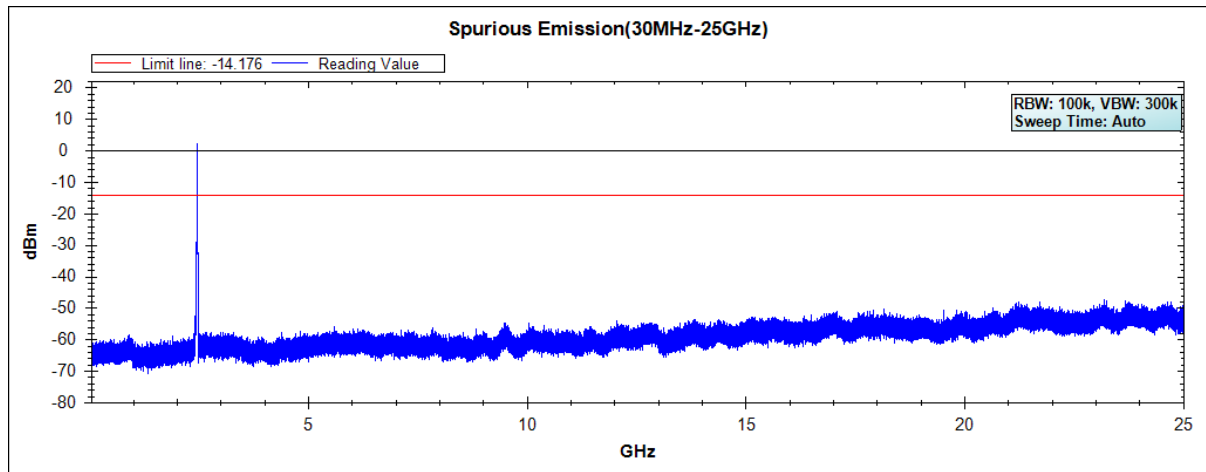

Note: The above test pattern is synthesized by multiple of the frequency range.

Product : Intel® Dual Band Wireless-AC 8260  
Test Item : RF Antenna Conducted Spurious  
Test Site : No.3 OATS  
Test Mode : Mode 2 SISO B: Transmit - 802.11n-40BW\_15Mbps(2.4G Band)

**Channel 03 (2422MHz) 30MHz -25GHz**

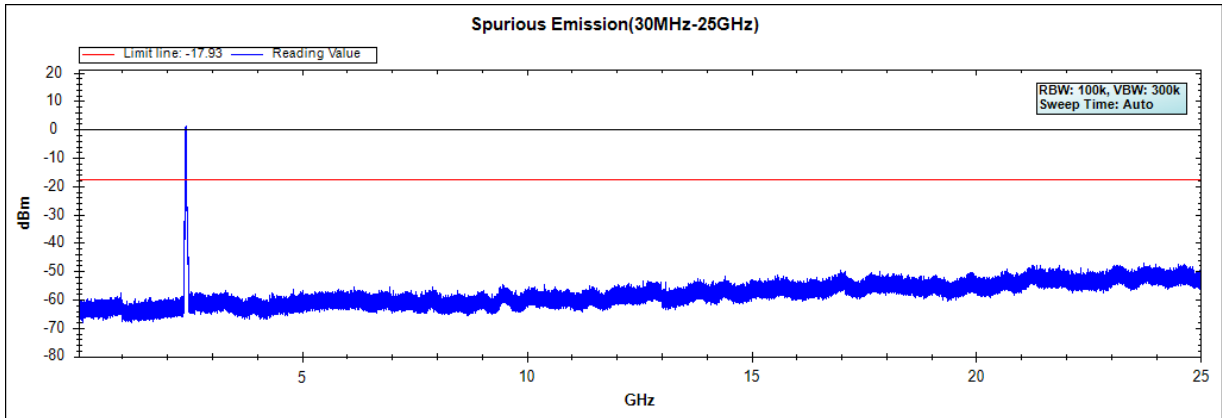

**Channel 06 (2437MHz) 30MHz -25GHz**

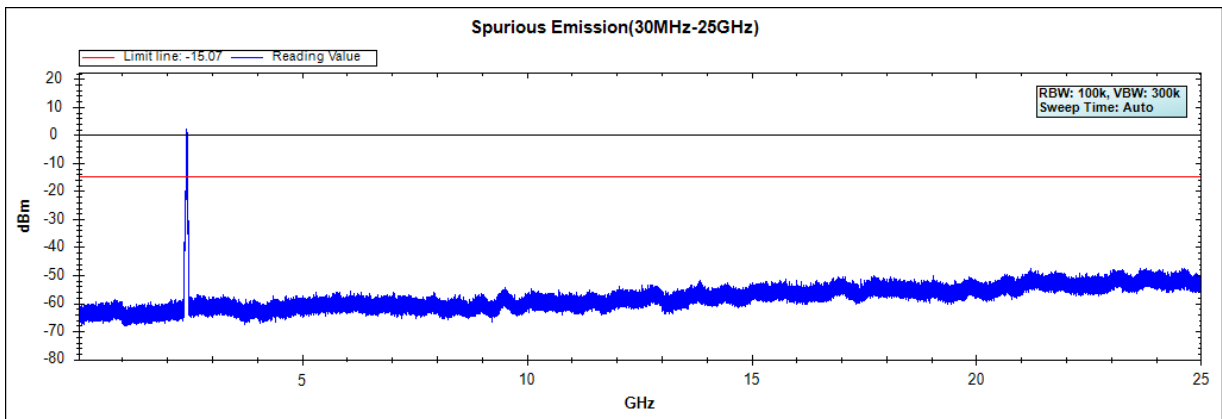

**Channel 09 (2452MHz) 30MHz -25GHz**

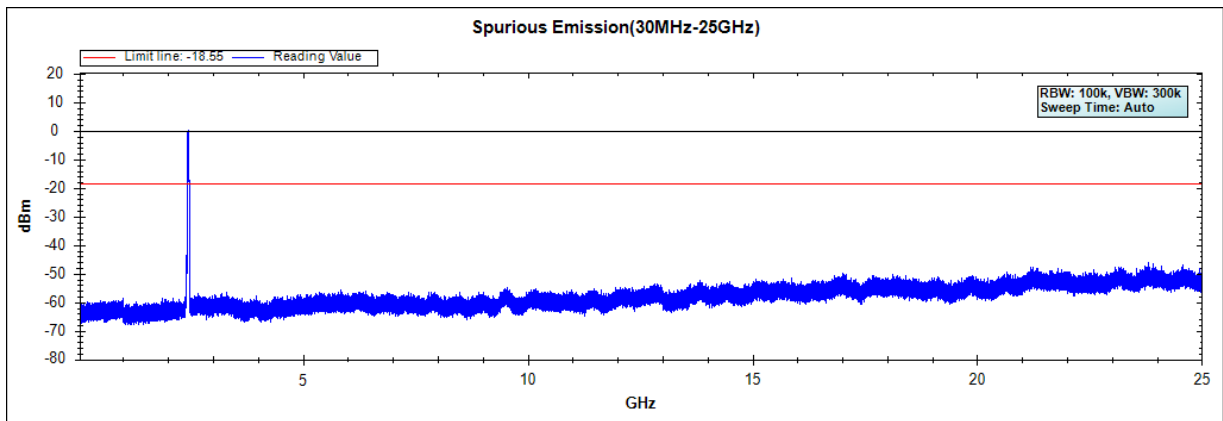

**Channel 10 (2457MHz) 30MHz -25GHz**

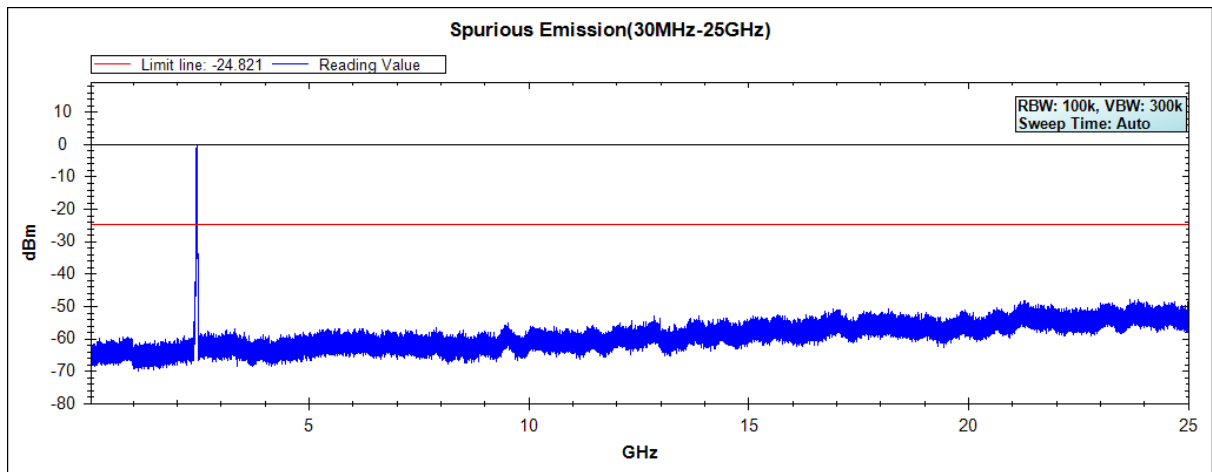

Note: The above test pattern is synthesized by multiple of the frequency range.

Product : Intel® Dual Band Wireless-AC 8260  
 Test Item : RF Antenna Conducted Spurious  
 Test Site : No.3 OATS  
 Test Mode : Mode 2 SISO B: Transmit - 802.11n-20BW\_7.2Mbps(5G Band)

**Channel 49 (5745MHz) 30MHz -40GHz**

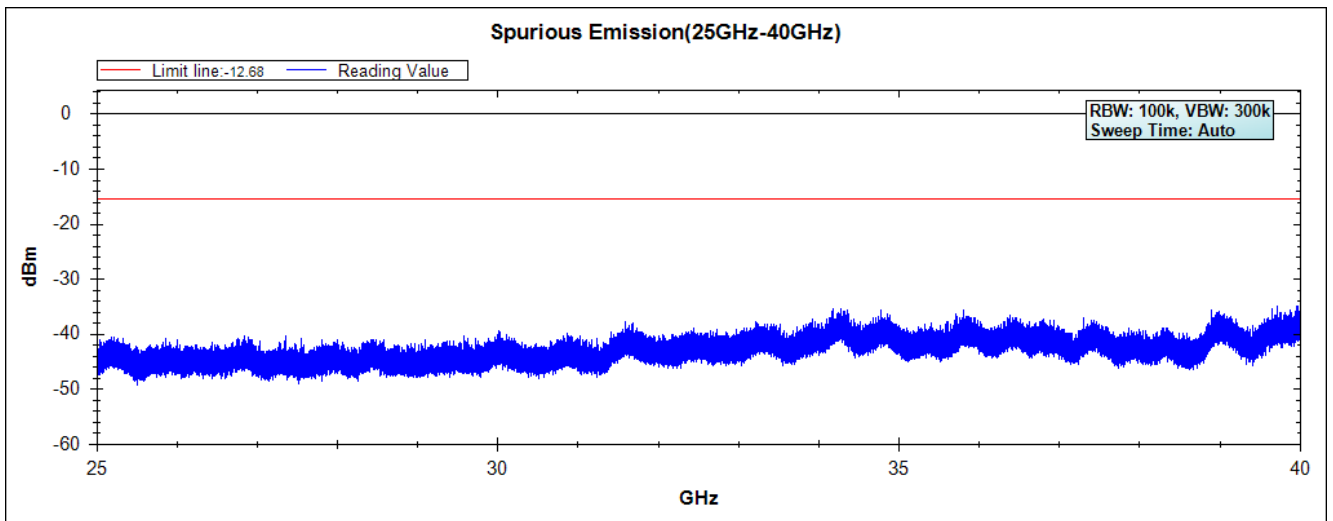
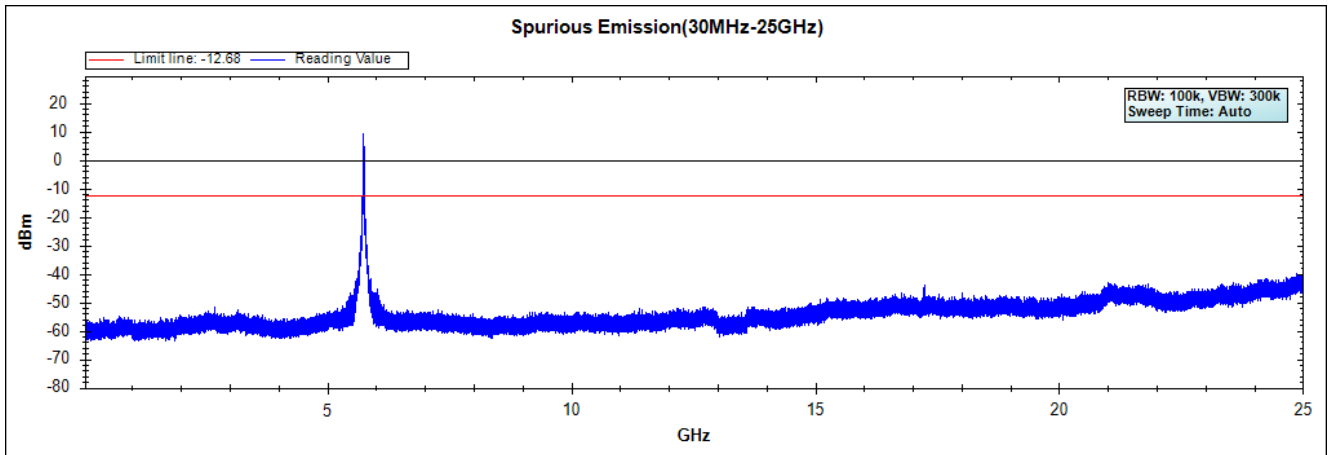

Note: The above test pattern is synthesized by multiple of the frequency range



**Channel 157 (5785MHz) 30MHz -40GHz**

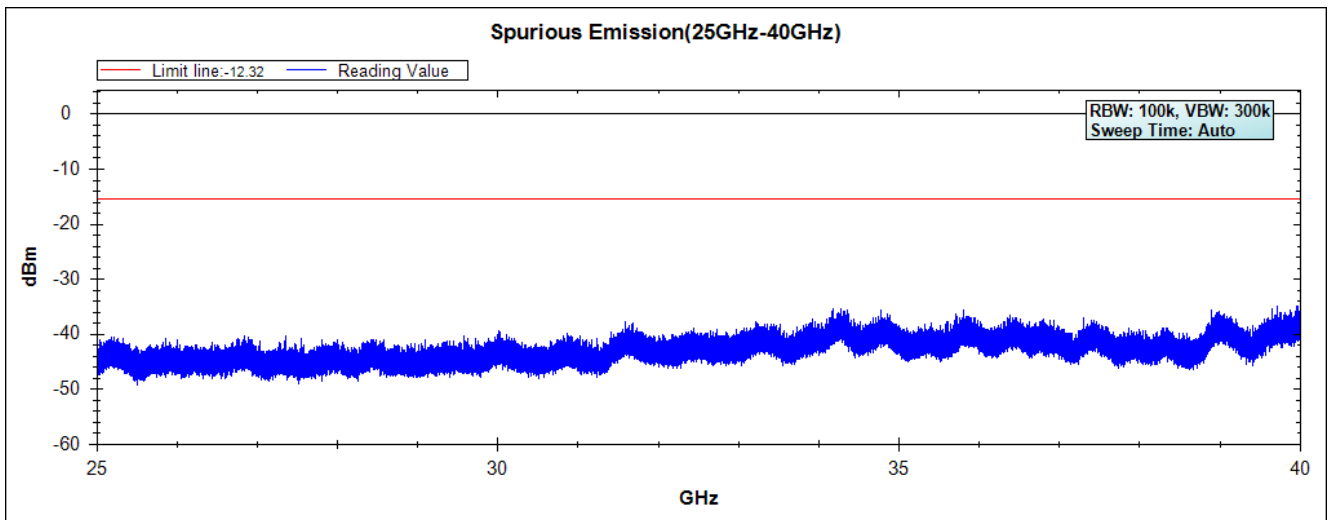
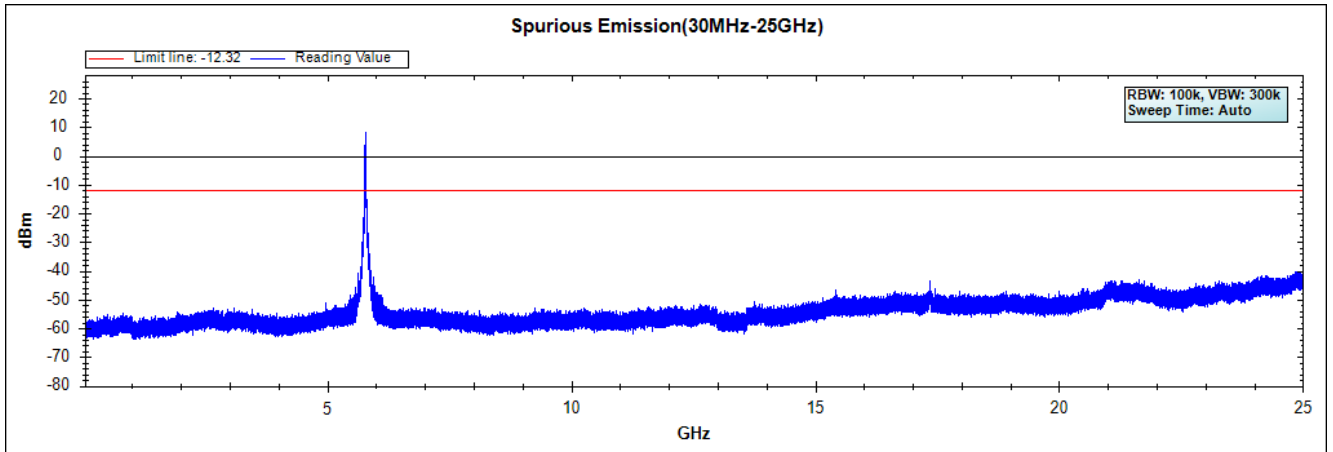

Note: The above test pattern is synthesized by multiple of the frequency range

Channel 165 (5825MHz) 30MHz -40GHz

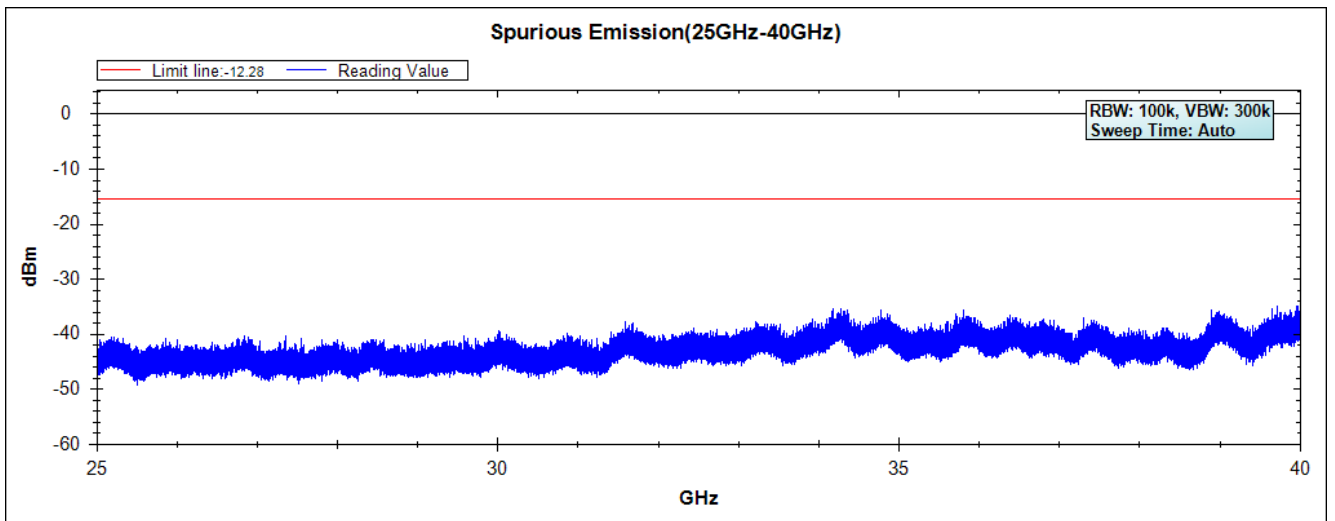
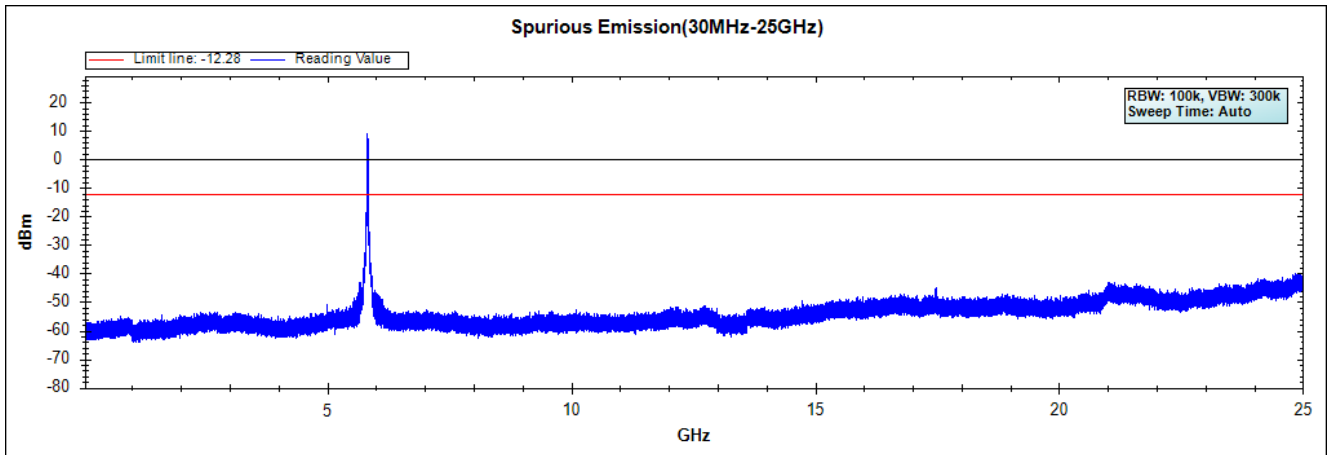

Note: The above test pattern is synthesized by multiple of the frequency range

Product : Intel® Dual Band Wireless-AC 8260  
 Test Item : RF Antenna Conducted Spurious  
 Test Site : No.3 OATS  
 Test Mode : Mode 2 SISO B: Transmit - 802.11n-40BW\_15Mbps(5G Band)

**Channel 151 (5755MHz) 30MHz -40GHz**

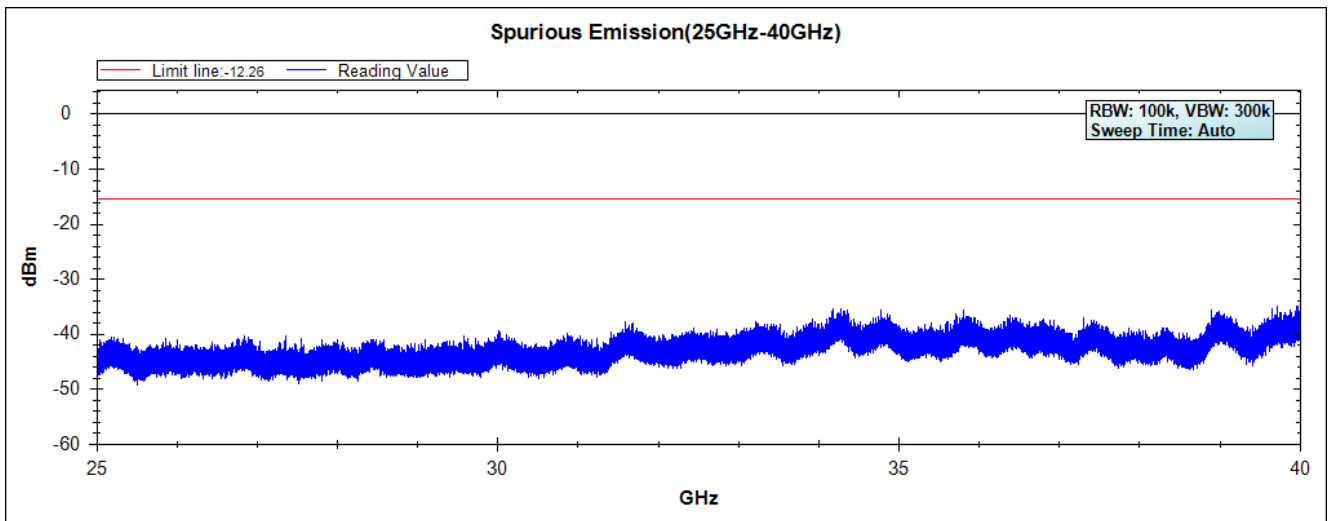
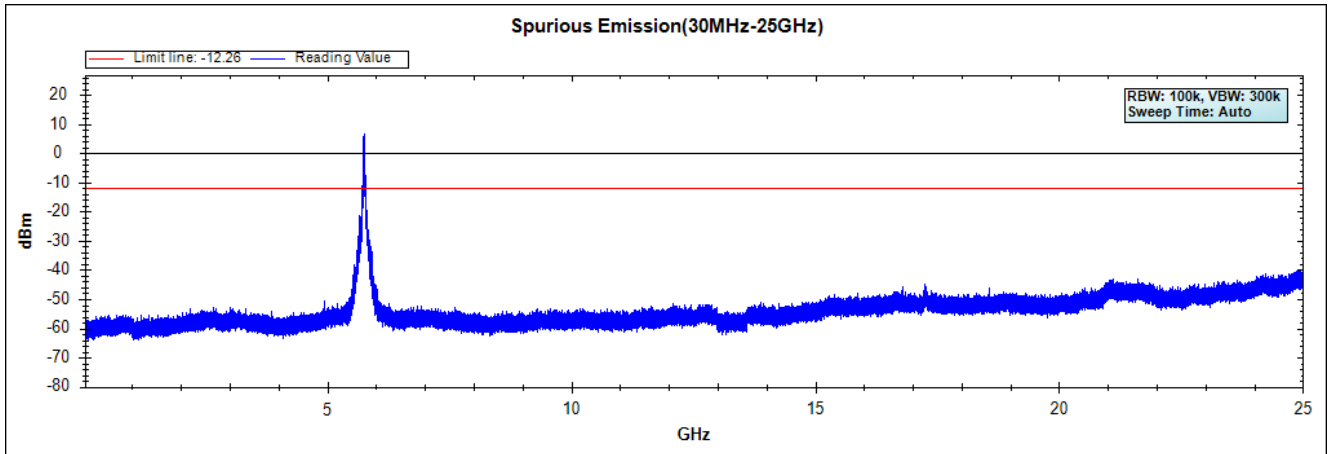

Note: The above test pattern is synthesized by multiple of the frequency range

Channel 159 (5795MHz) 30MHz -40GHz

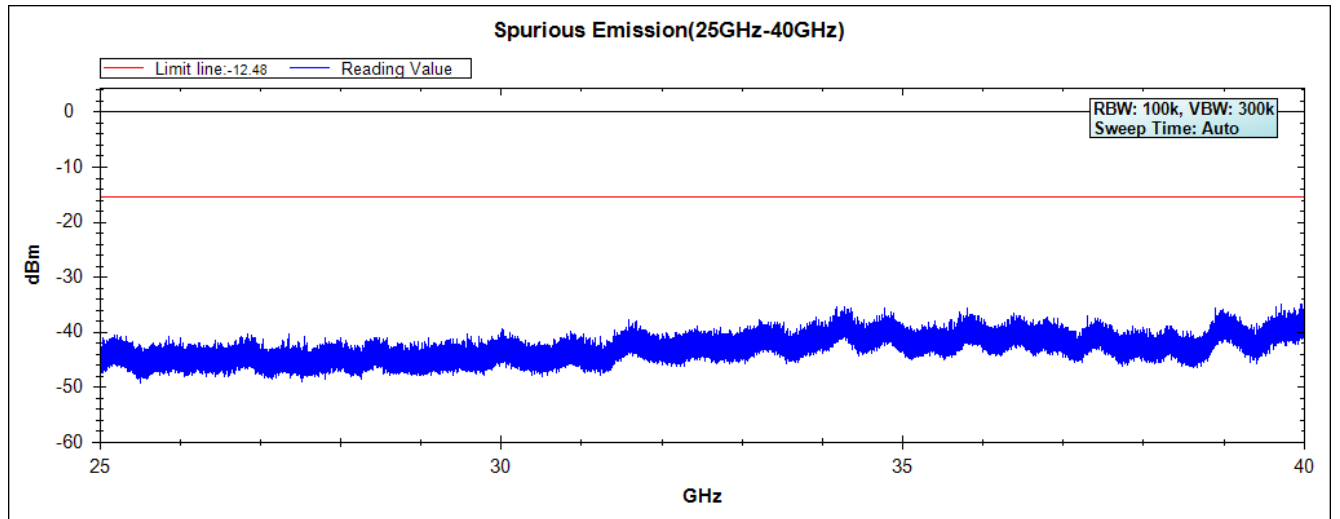
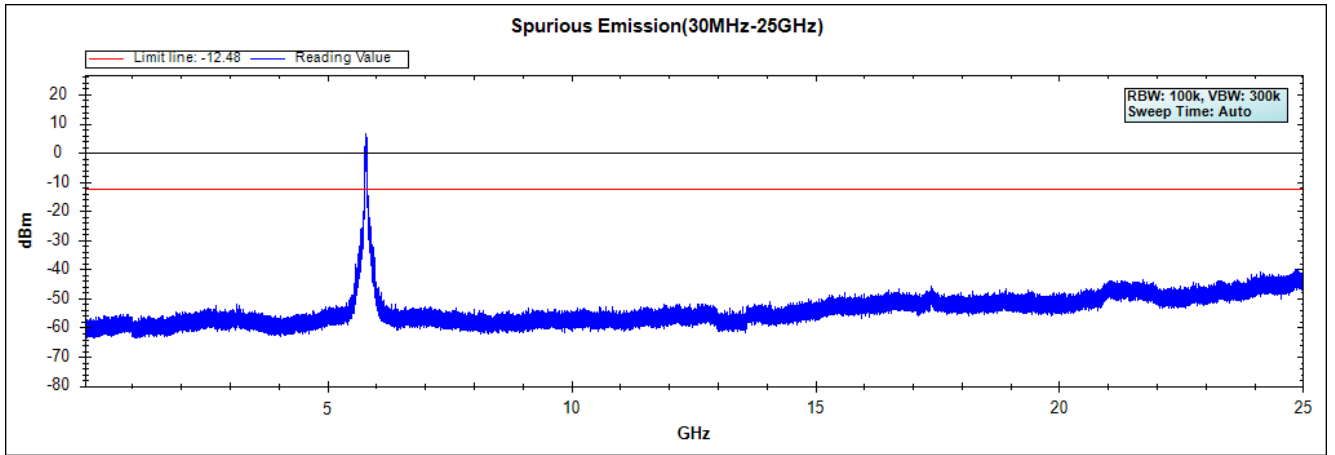

Note: The above test pattern is synthesized by multiple of the frequency range

Product : Intel® Dual Band Wireless-AC 8260  
 Test Item : RF Antenna Conducted Spurious  
 Test Site : No.3 OATS  
 Test Mode : Mode 2 SISO B: Transmit - 802.11ac-80BW\_32.5Mbps(5G Band)

**Channel 155 (5775MHz) 30MHz -40GHz**

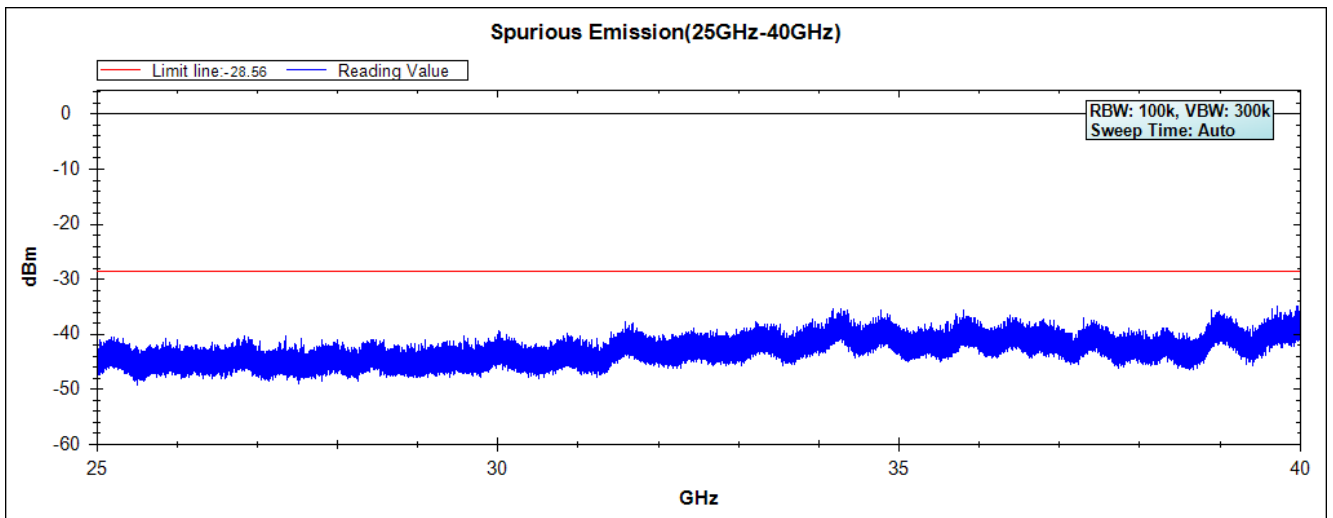
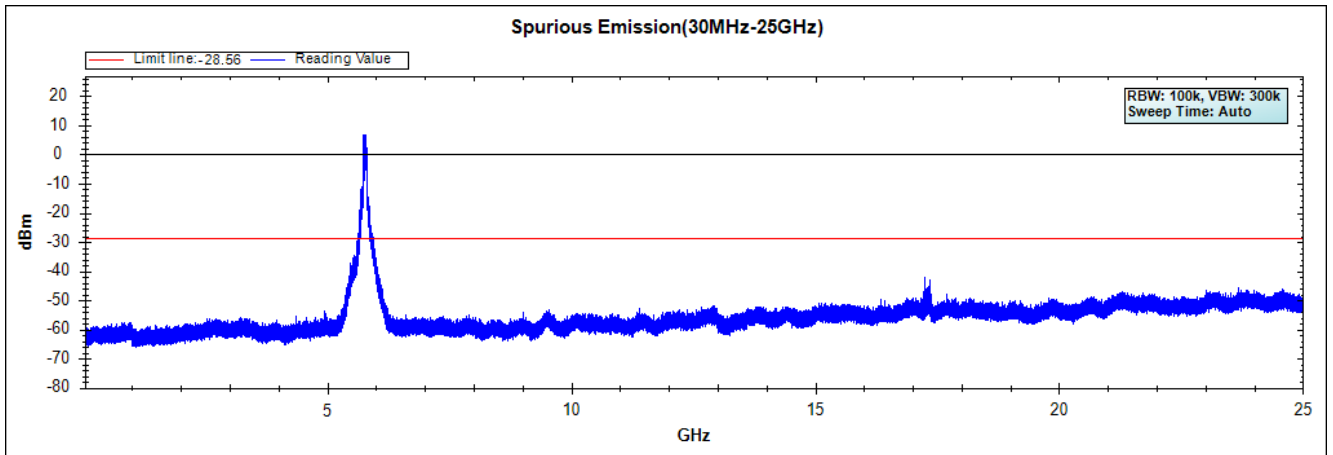

Note: The above test pattern is synthesized by multiple of the frequency range

Product : Intel® Dual Band Wireless-AC 8260  
 Test Item : RF Antenna Conducted Spurious  
 Test Site : No.3 OATS  
 Test Mode : Mode 3 MIMO: Transmit - 802.11n-20BW\_14.4Mbps(2.4G Band)

**Chaia A**

**Channel 01 (2412MHz) 30MHz -25GHz**

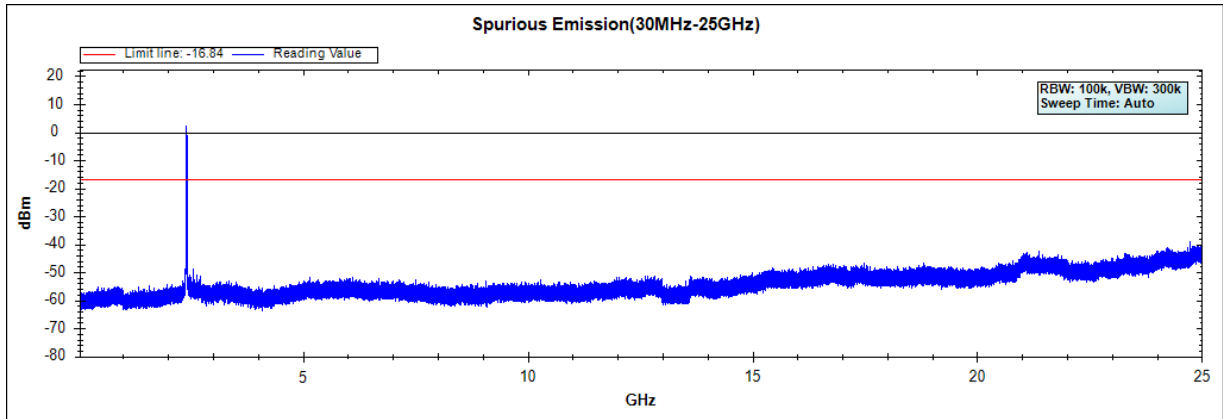

**Channel 06 (2437MHz) 30MHz -25GHz**

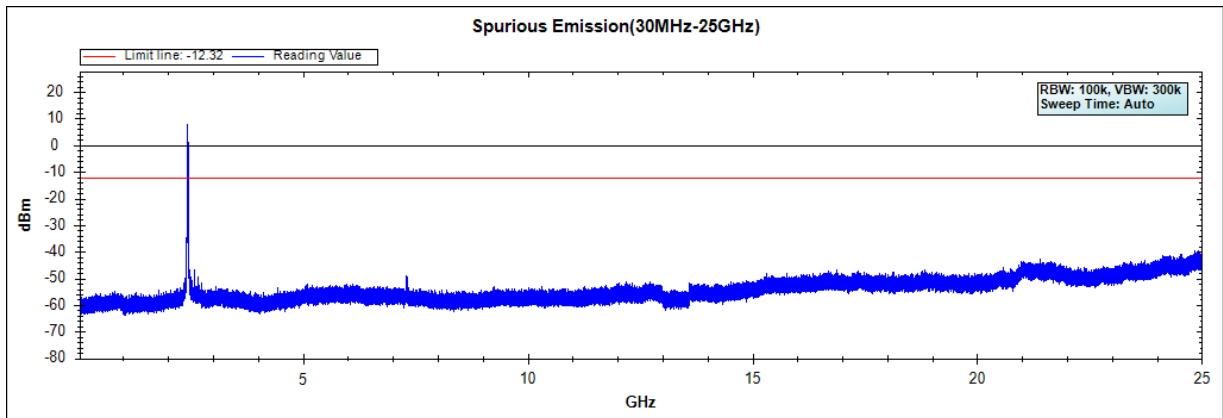

**Channel 11 (2462MHz) 30MHz -25GHz**

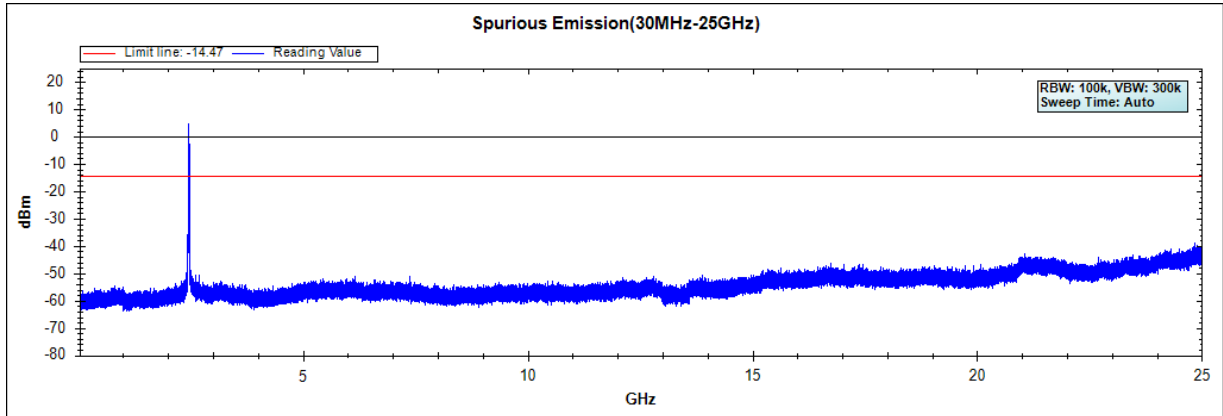

**Channel 12 (2467MHz) 30MHz -25GHz**

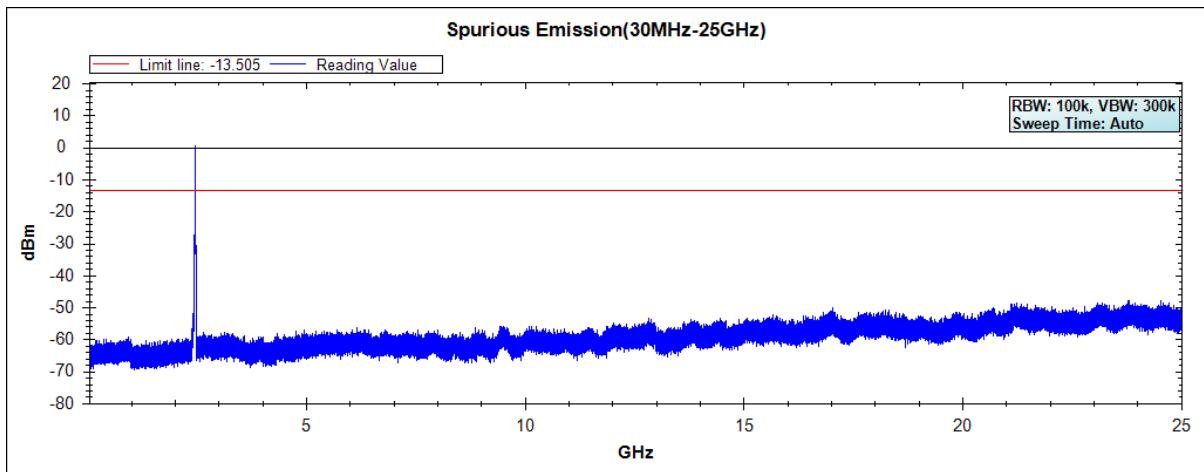

Note: The above test pattern is synthesized by multiple of the frequency range.

Product : Intel® Dual Band Wireless-AC 8260  
Test Item : RF Antenna Conducted Spurious  
Test Site : No.3 OATS  
Test Mode : Mode 3 MIMO: Transmit - 802.11n-40BW\_30Mbps(2.4G Band)

**Chaia A**

**Channel 03 (2422MHz) 30MHz -25GHz**

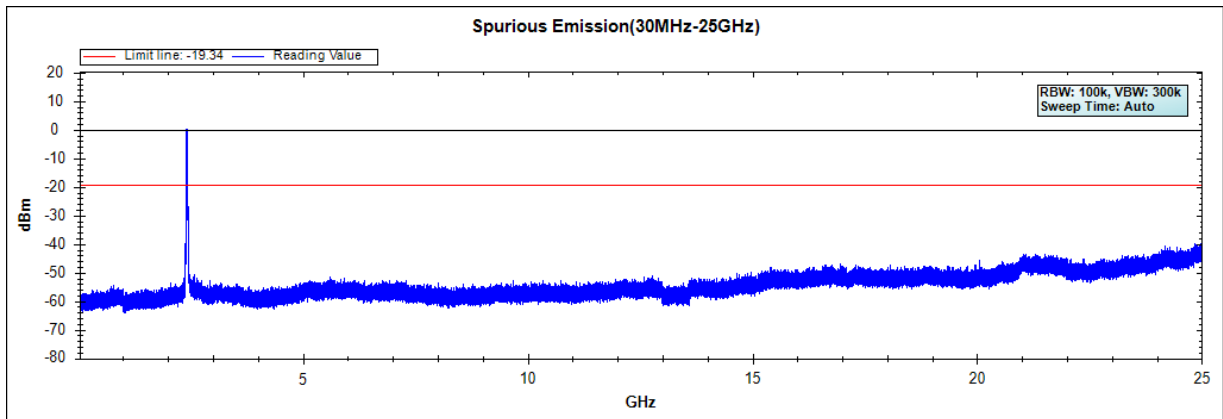

**Channel 06 (2437MHz) 30MHz -25GHz**

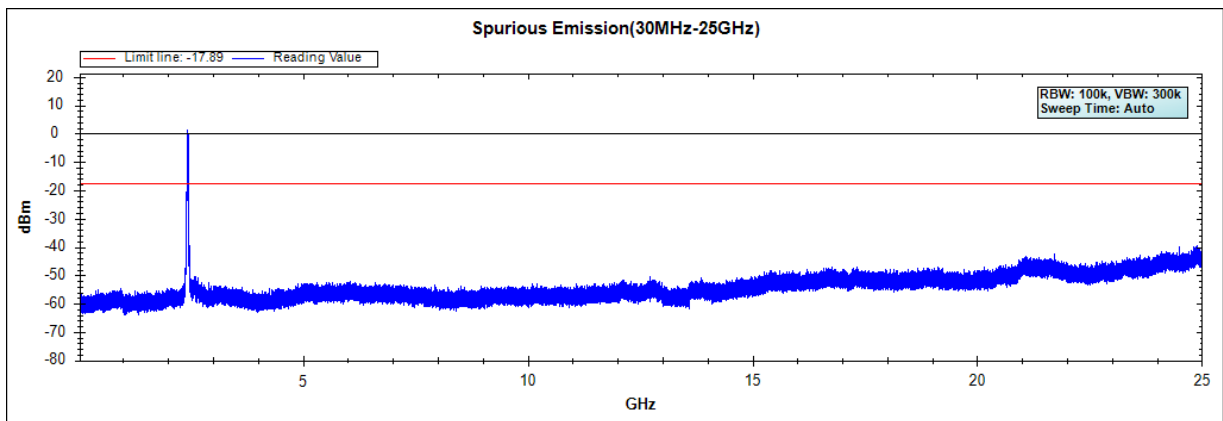



**Channel 09 (2452MHz) 30MHz -25GHz**

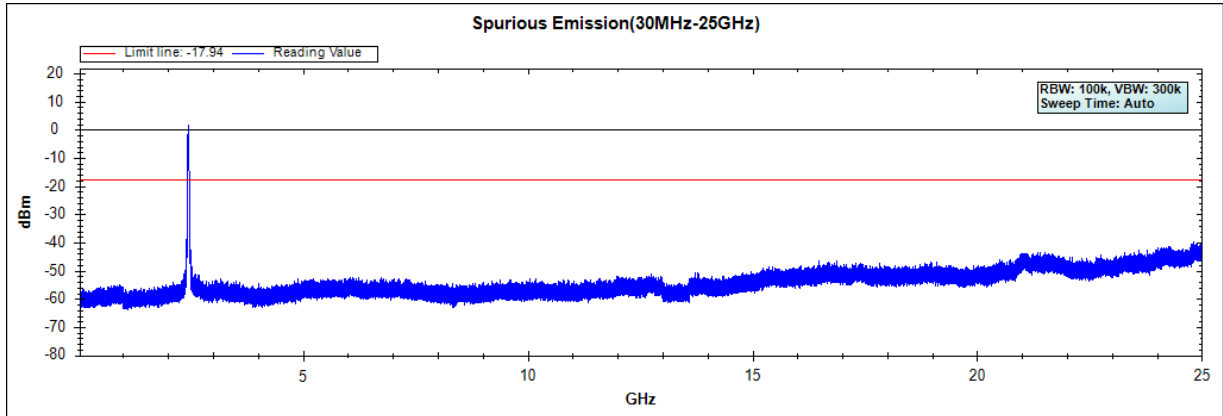

**Channel 10 (2457MHz) 30MHz -25GHz**

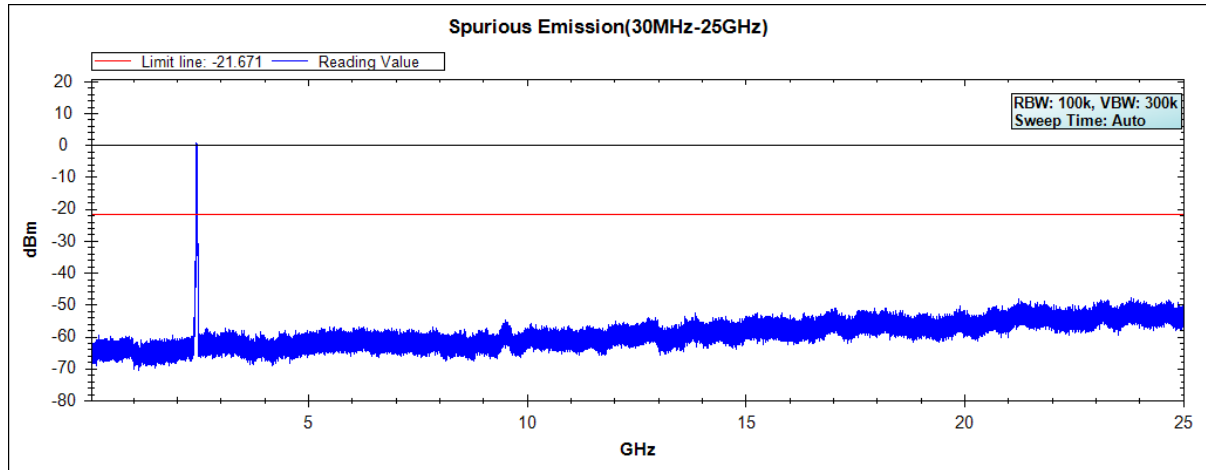

Note: The above test pattern is synthesized by multiple of the frequency range.

Product : Intel® Dual Band Wireless-AC 8260  
Test Item : RF Antenna Conducted Spurious  
Test Site : No.3 OATS  
Test Mode : Mode 3 MIMO: Transmit - 802.11n-20BW\_14.4Mbps(5G Band)

**Chaia A**

**Channel 49 (5745MHz) 30MHz -40GHz**

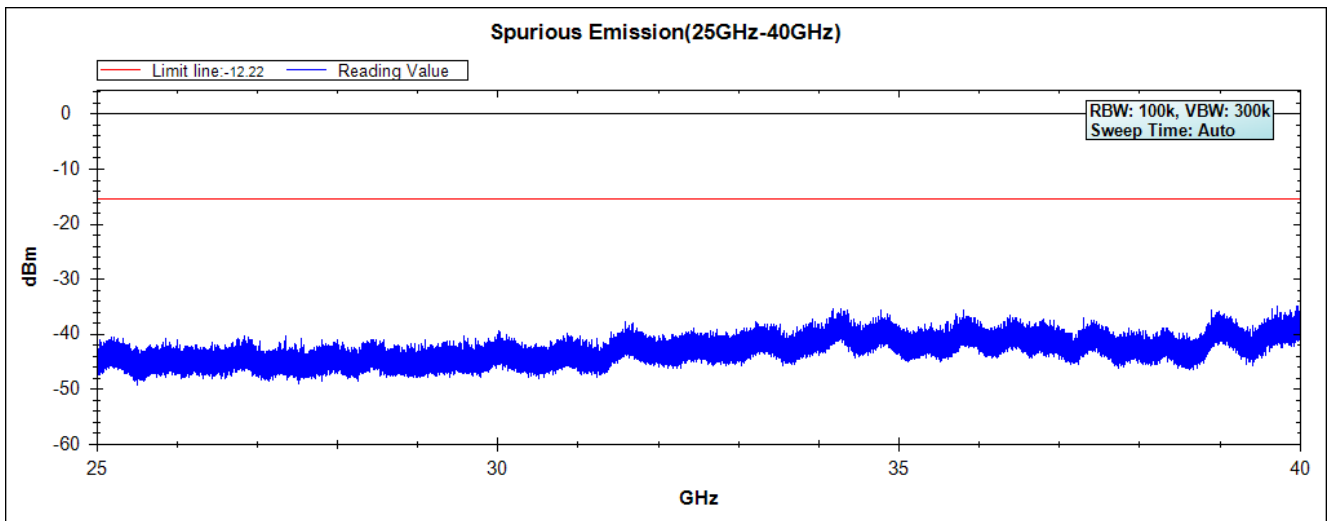
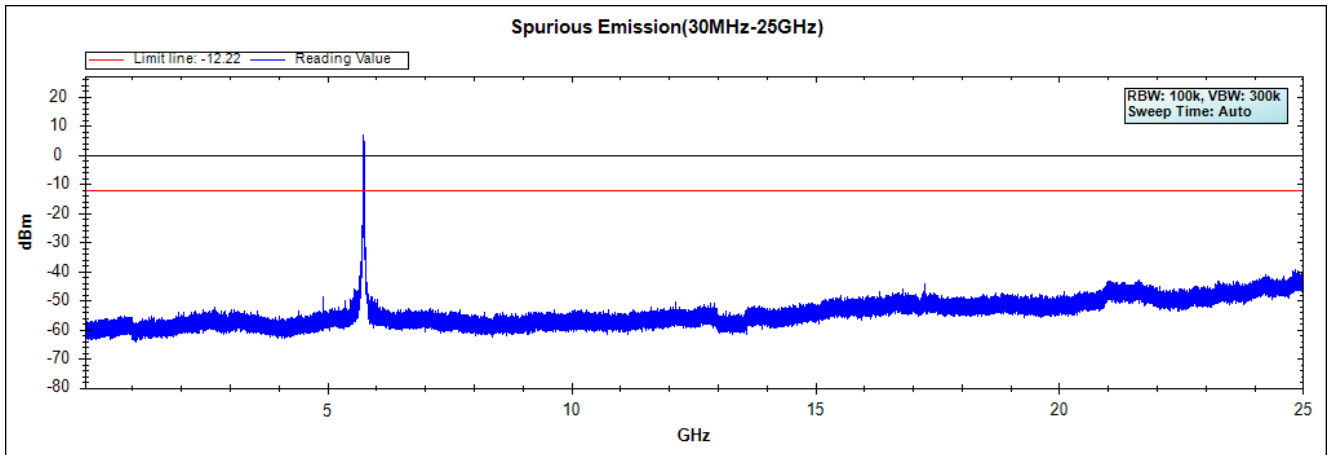

Note: The above test pattern is synthesized by multiple of the frequency range

Channel 157 (5785MHz) 30MHz -40GHz

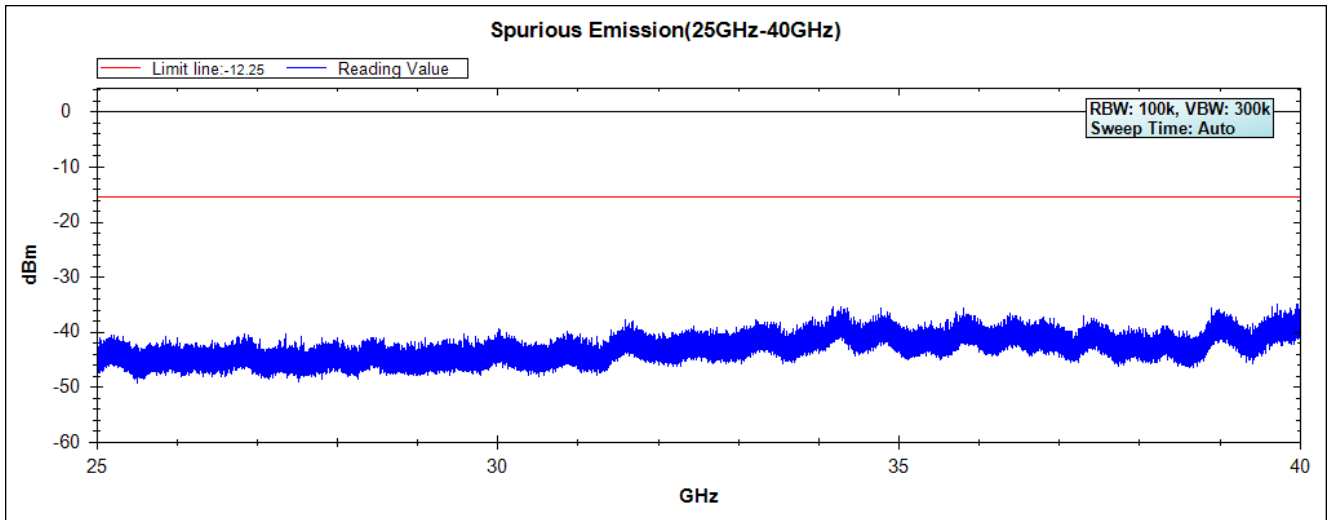
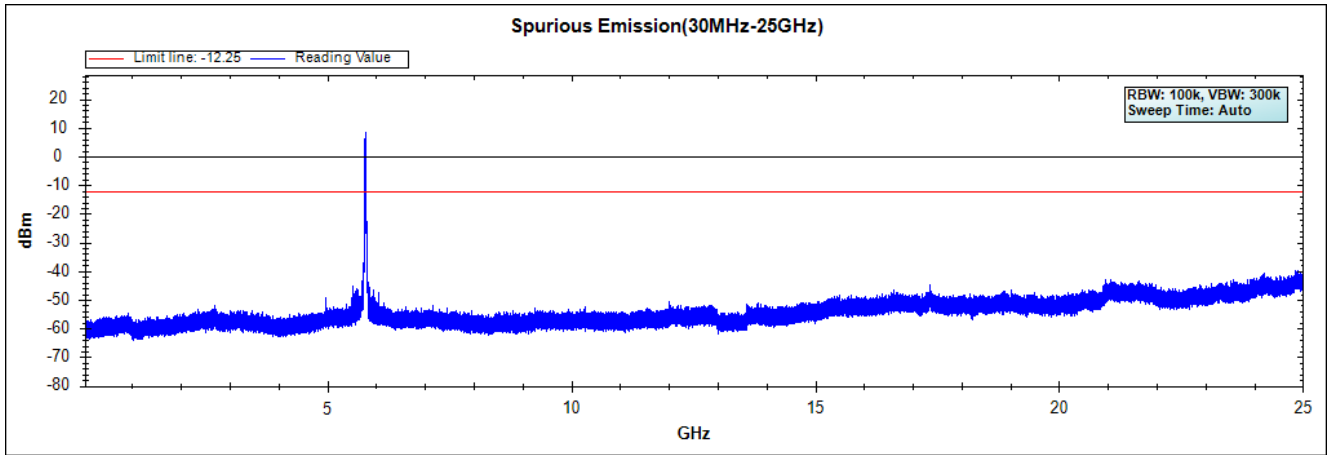

Note: The above test pattern is synthesized by multiple of the frequency range

Channel 165 (5825MHz) 30MHz -40GHz

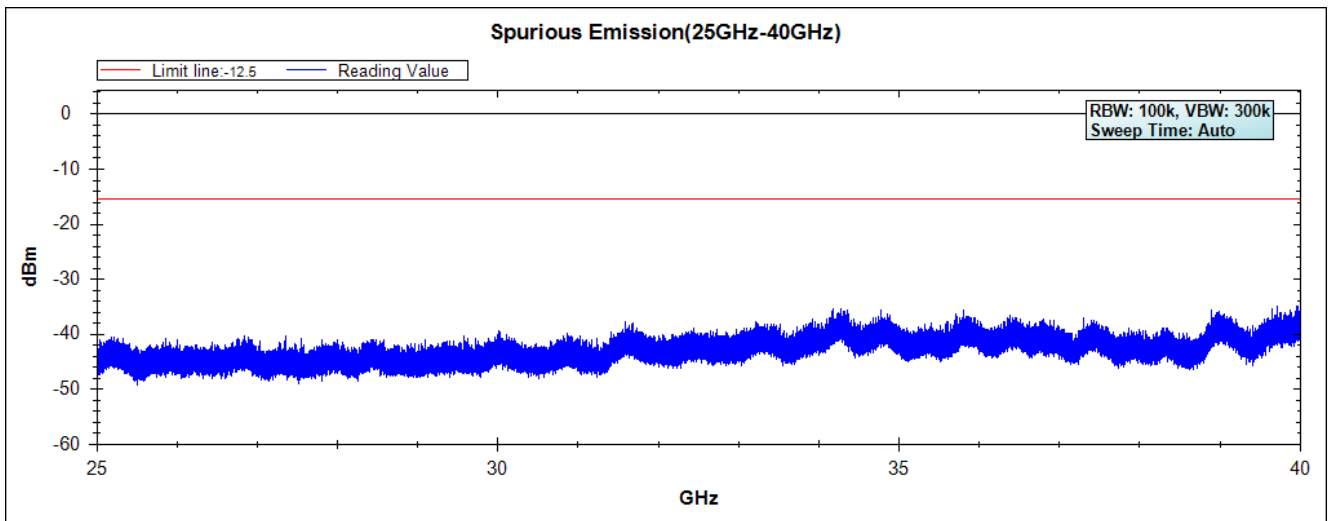
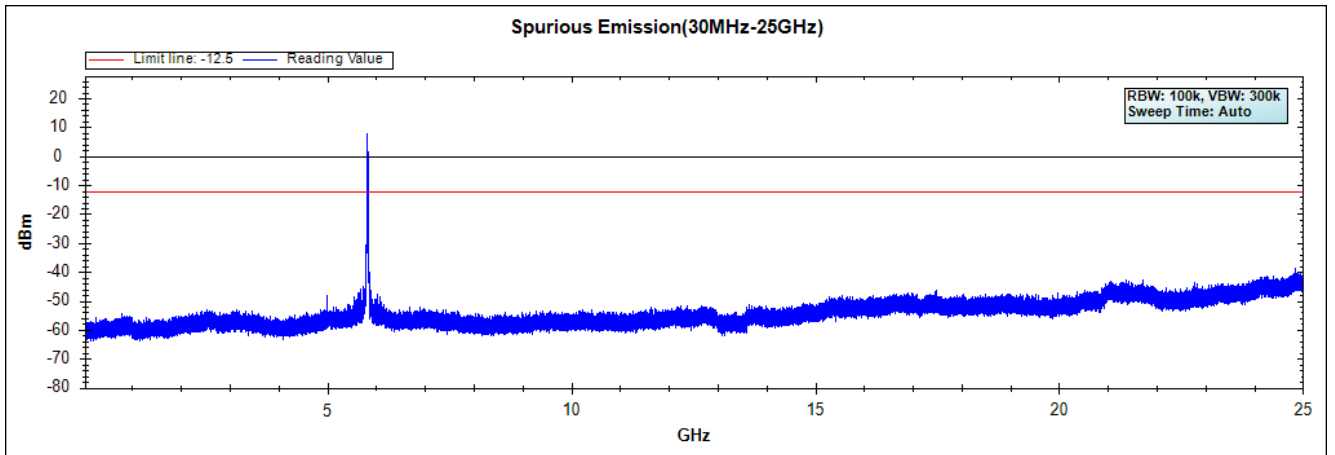

Note: The above test pattern is synthesized by multiple of the frequency range

Product : Intel® Dual Band Wireless-AC 8260  
 Test Item : RF Antenna Conducted Spurious  
 Test Site : No.3 OATS  
 Test Mode : Mode 3 MIMO: Transmit - 802.11n-40BW\_30Mbps(5G Band)

**Chaia A**

**Channel 151 (5755MHz) 30MHz -40GHz**

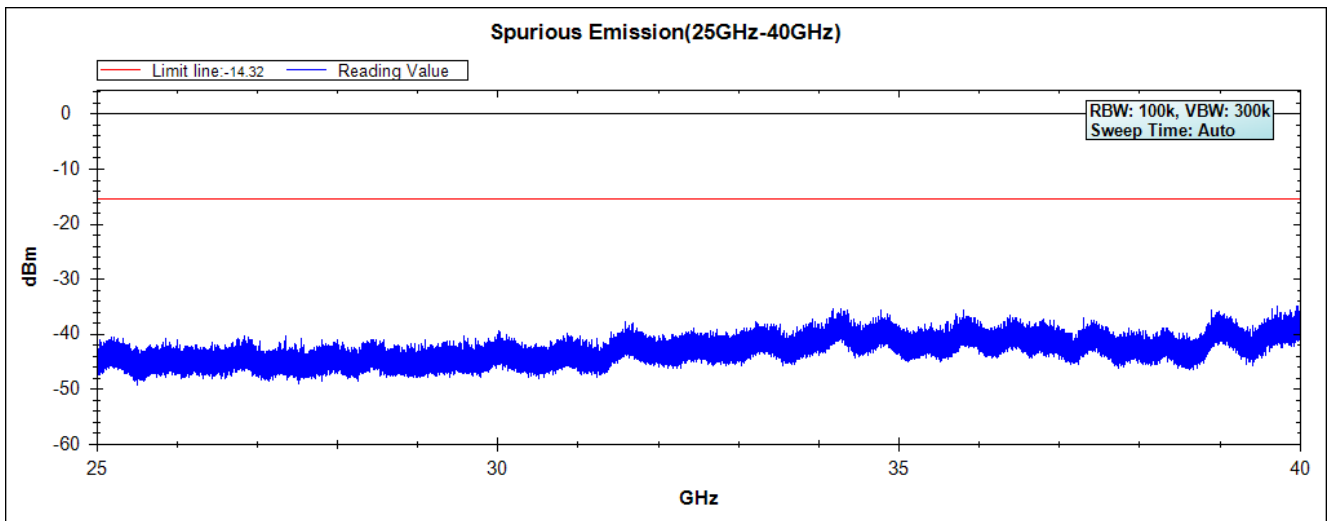
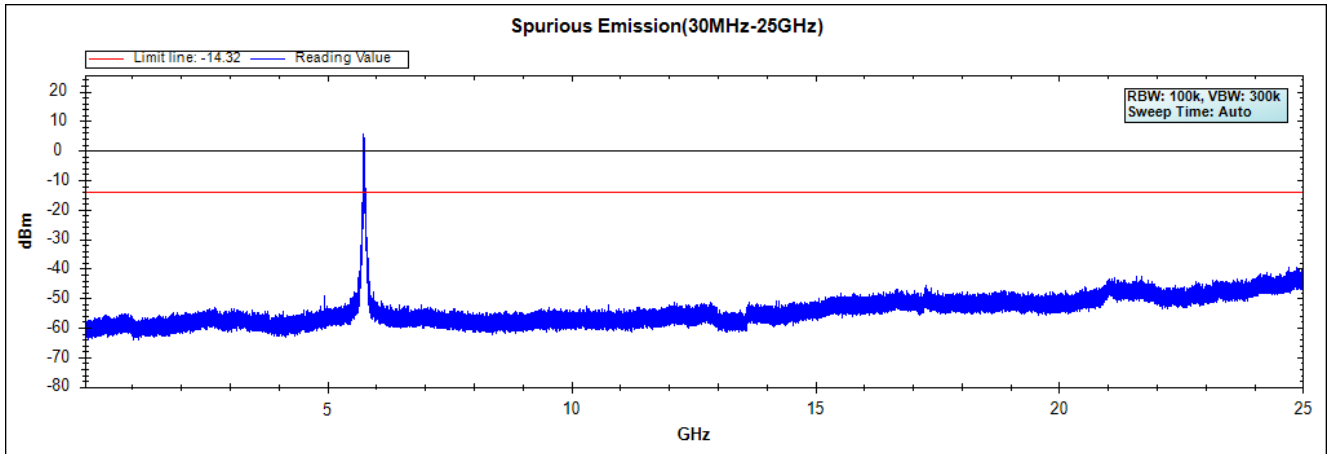

Note: The above test pattern is synthesized by multiple of the frequency range

Channel 159 (5795MHz) 30MHz -40GHz

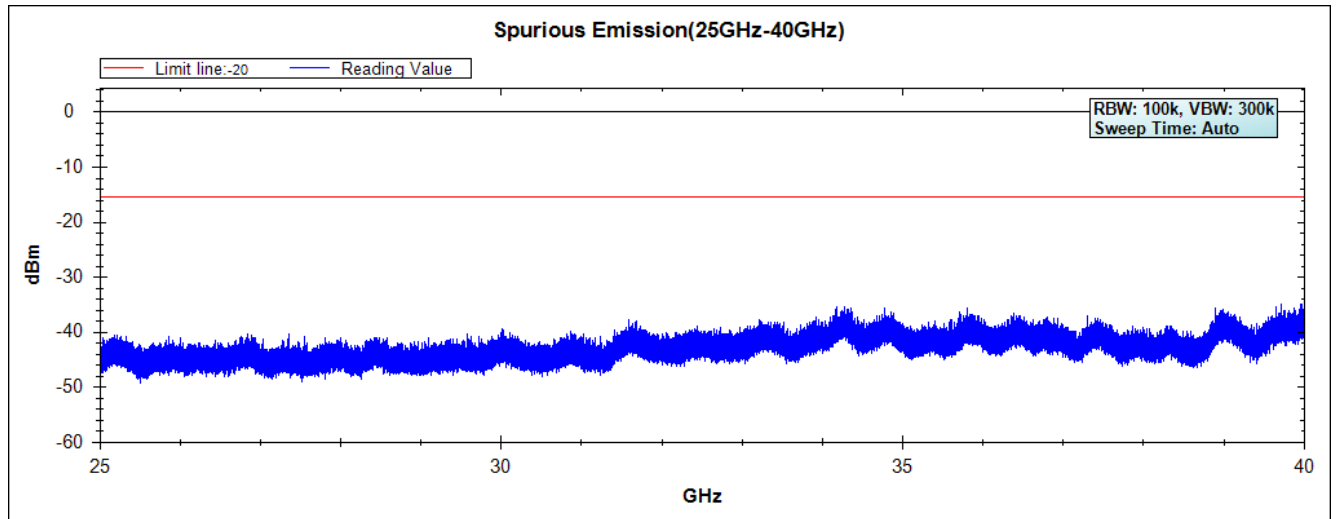
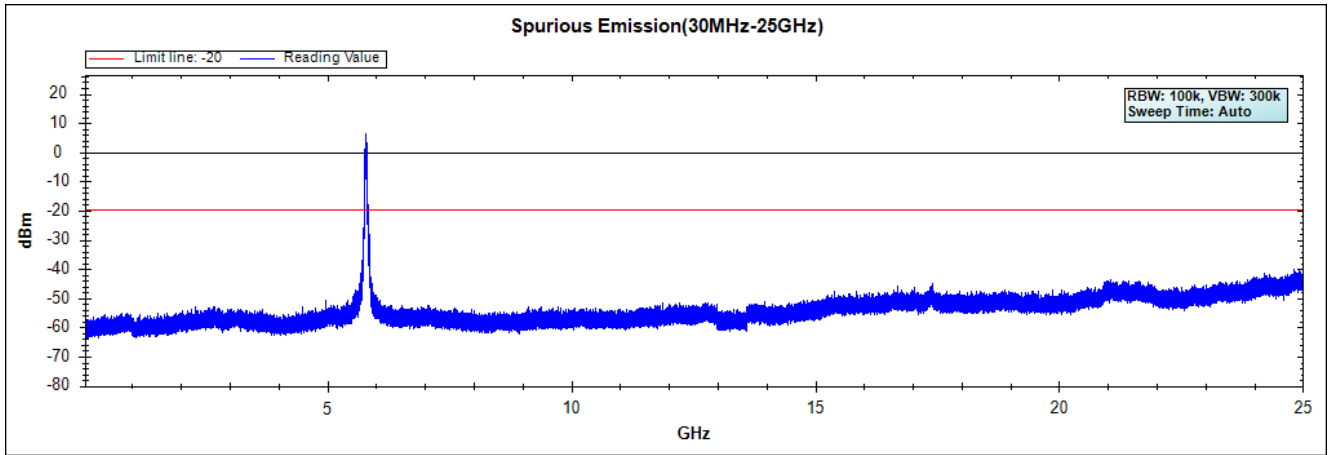

Note: The above test pattern is synthesized by multiple of the frequency range

Product : Intel® Dual Band Wireless-AC 8260  
Test Item : RF Antenna Conducted Spurious  
Test Site : No.3 OATS  
Test Mode : Mode 3 MIMO: Transmit - 802.11ac-80BW\_65Mbps(5G Band)

**Chaia A**

**Channel 155 (5775MHz) 30MHz -40GHz**

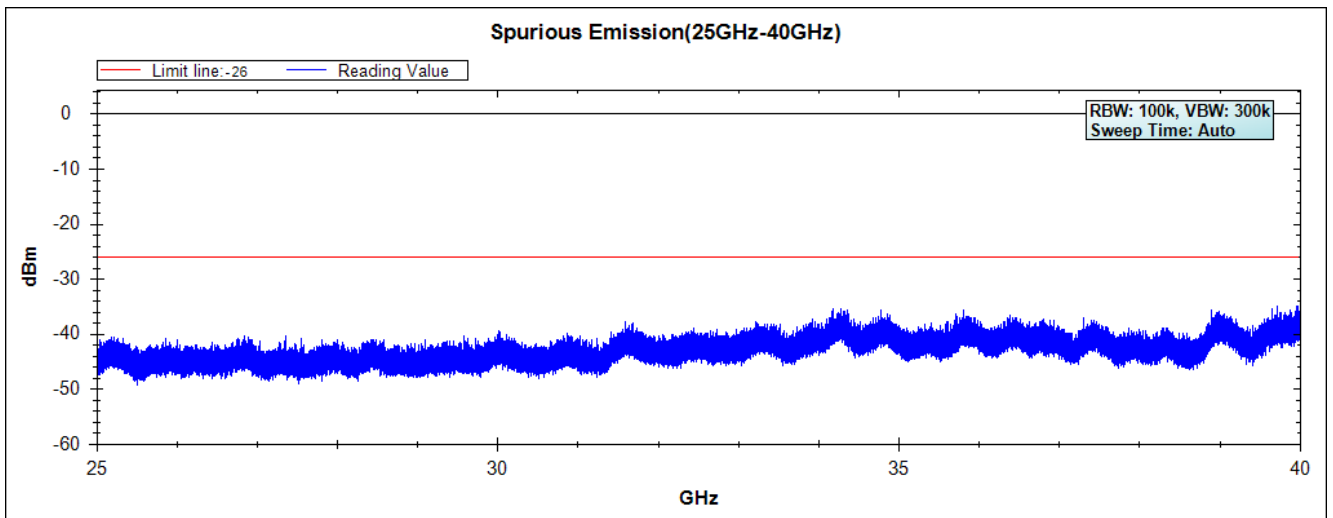
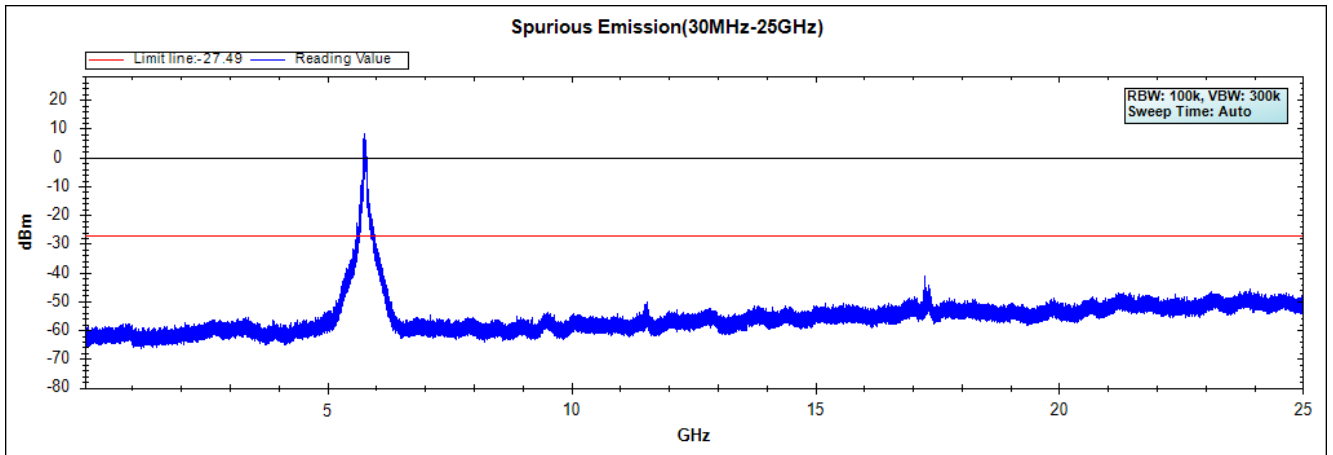

Note: The above test pattern is synthesized by multiple of the frequency range

Product : Intel® Dual Band Wireless-AC 8260  
Test Item : RF Antenna Conducted Spurious  
Test Site : No.3 OATS  
Test Mode : Mode 3 MIMO: Transmit - 802.11n-20BW\_14.4Mbps(2.4G Band)

**Chaia B**

**Channel 01 (2412MHz) 30MHz -25GHz**

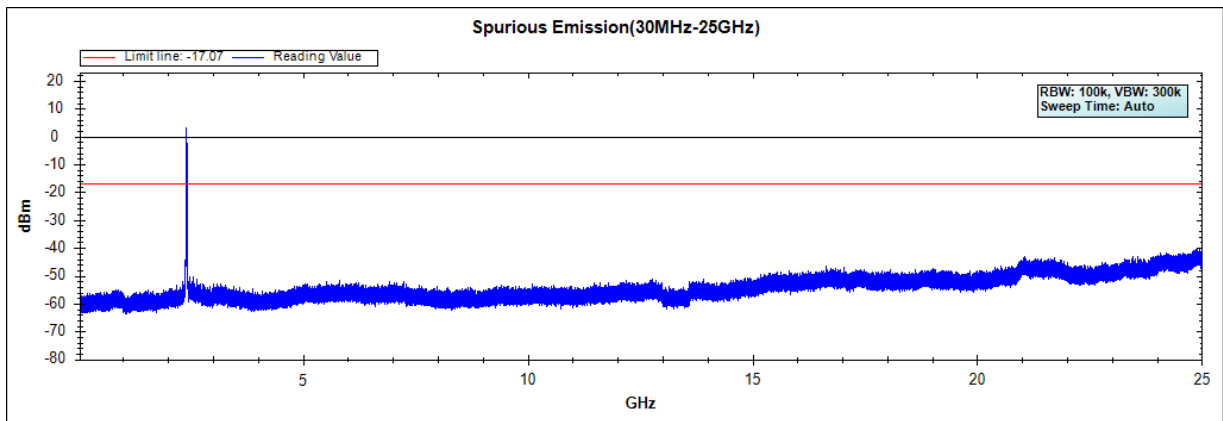

**Channel 06 (2437MHz) 30MHz -25GHz**

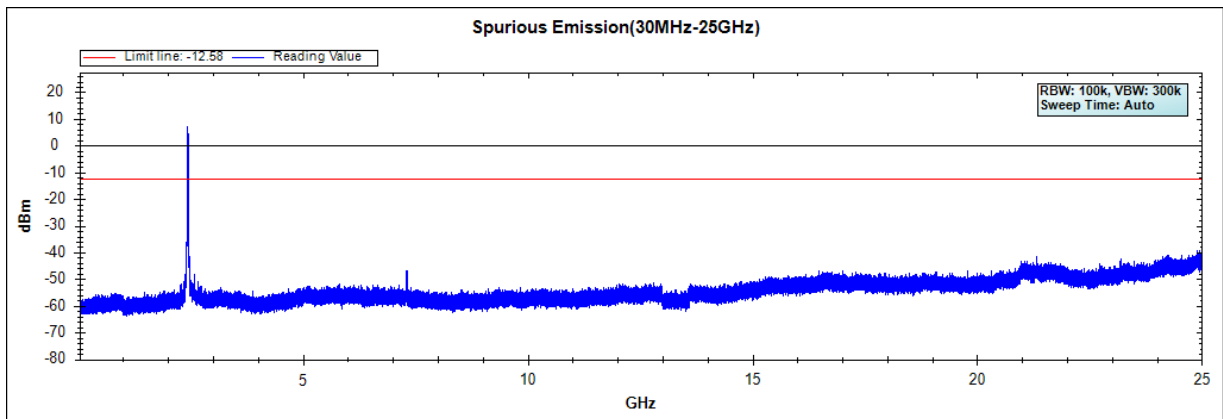



**Channel 11 (2462MHz) 30MHz -25GHz**

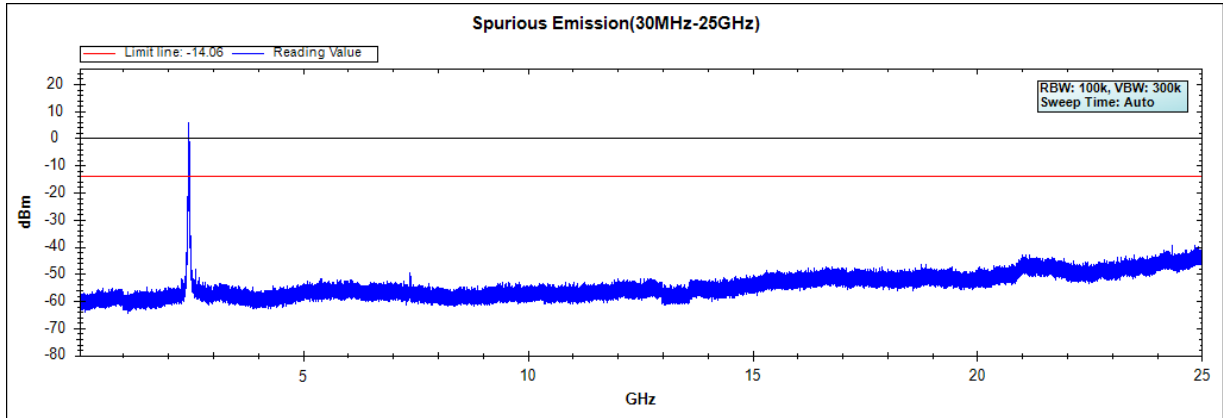

**Channel 12 (2467MHz) 30MHz -25GHz**

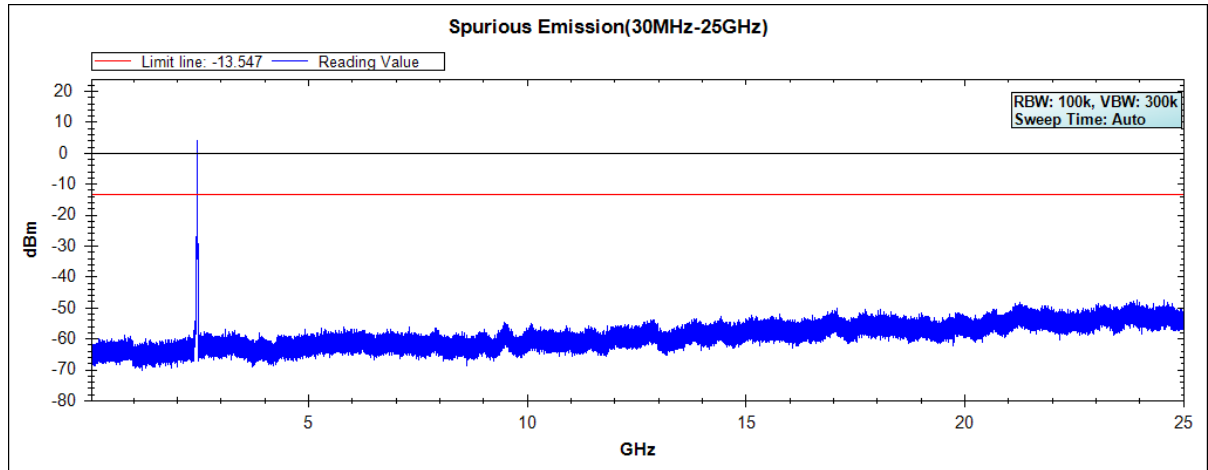

Note: The above test pattern is synthesized by multiple of the frequency range.

Product : Intel® Dual Band Wireless-AC 8260  
Test Item : RF Antenna Conducted Spurious  
Test Site : No.3 OATS  
Test Mode : Mode 3 MIMO: Transmit - 802.11n-40BW\_30Mbps(2.4G Band)

**Chaia B**

**Channel 03 (2422MHz) 30MHz -25GHz**

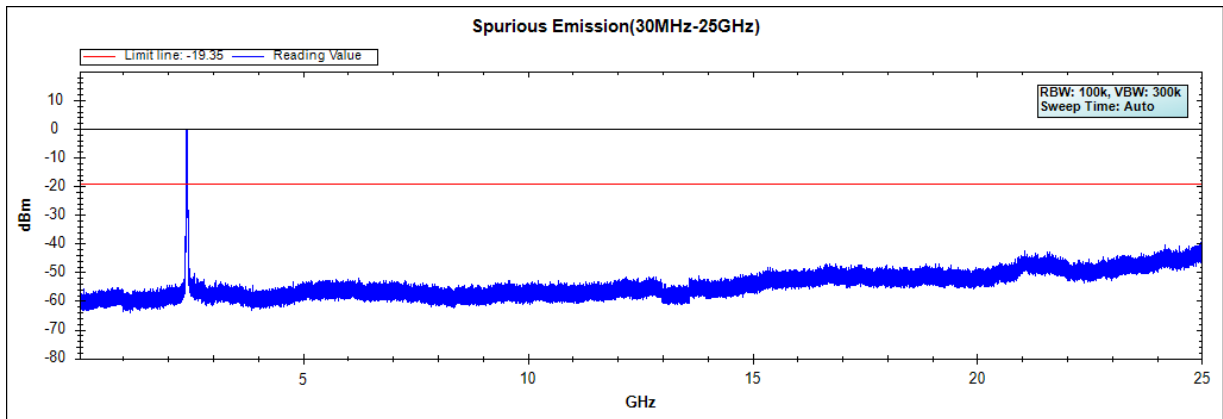

**Channel 06 (2437MHz) 30MHz -25GHz**

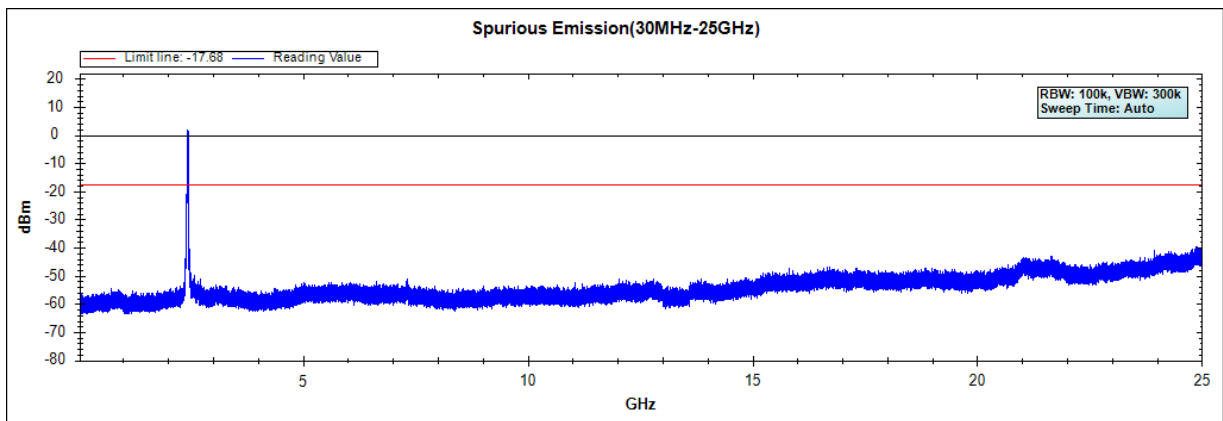

**Channel 09 (2452MHz) 30MHz -25GHz**

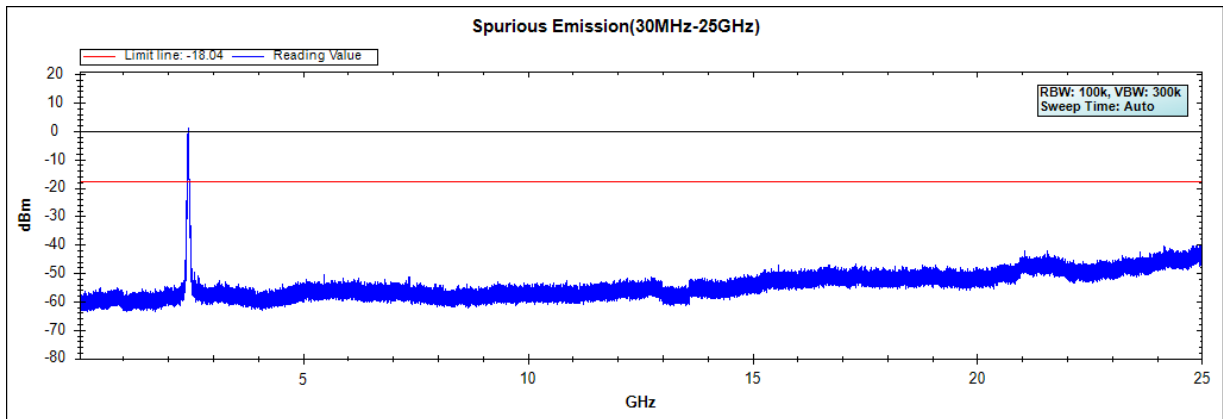

**Channel 10 (2457MHz) 30MHz -25GHz**

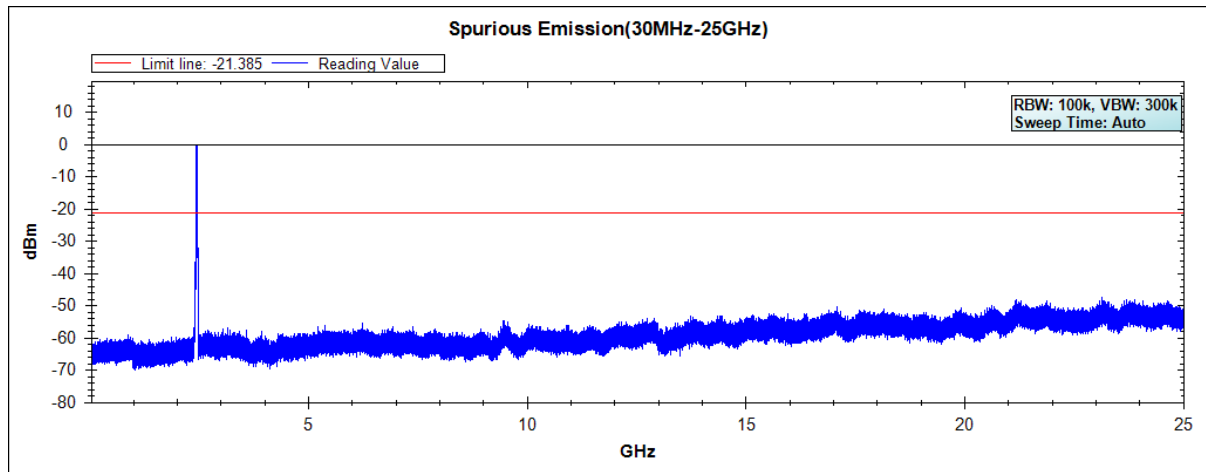

Note: The above test pattern is synthesized by multiple of the frequency range.

Product : Intel® Dual Band Wireless-AC 8260  
 Test Item : RF Antenna Conducted Spurious  
 Test Site : No.3 OATS  
 Test Mode : Mode 3 MIMO: Transmit - 802.11n-20BW\_14.4Mbps(5G Band)

**Chaia B**

**Channel 49 (5745MHz) 30MHz -40GHz**

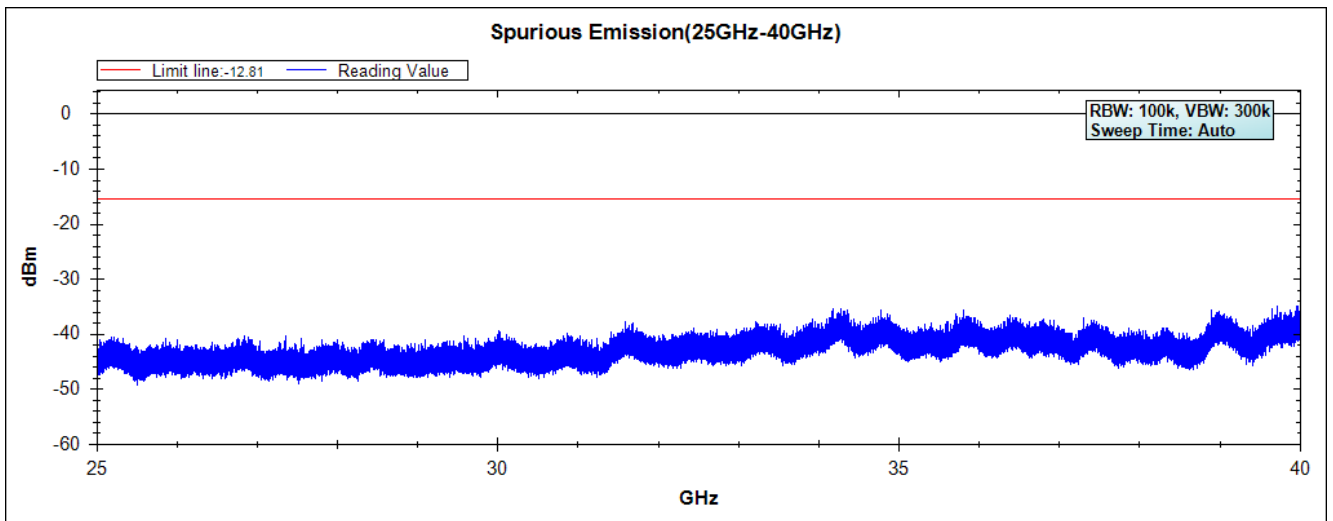
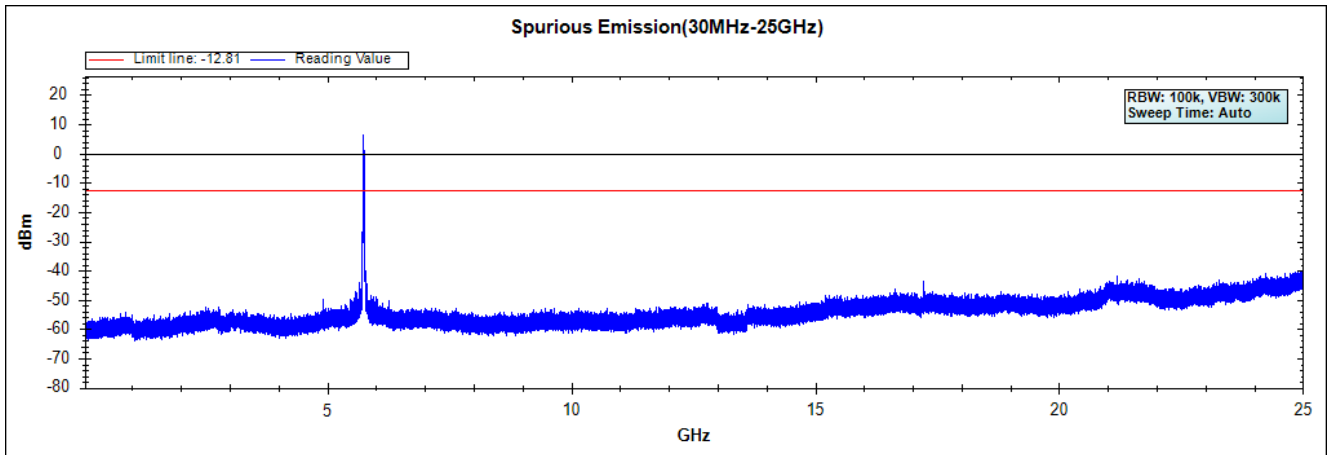

Note: The above test pattern is synthesized by multiple of the frequency range

Channel 157 (5785MHz) 30MHz -40GHz

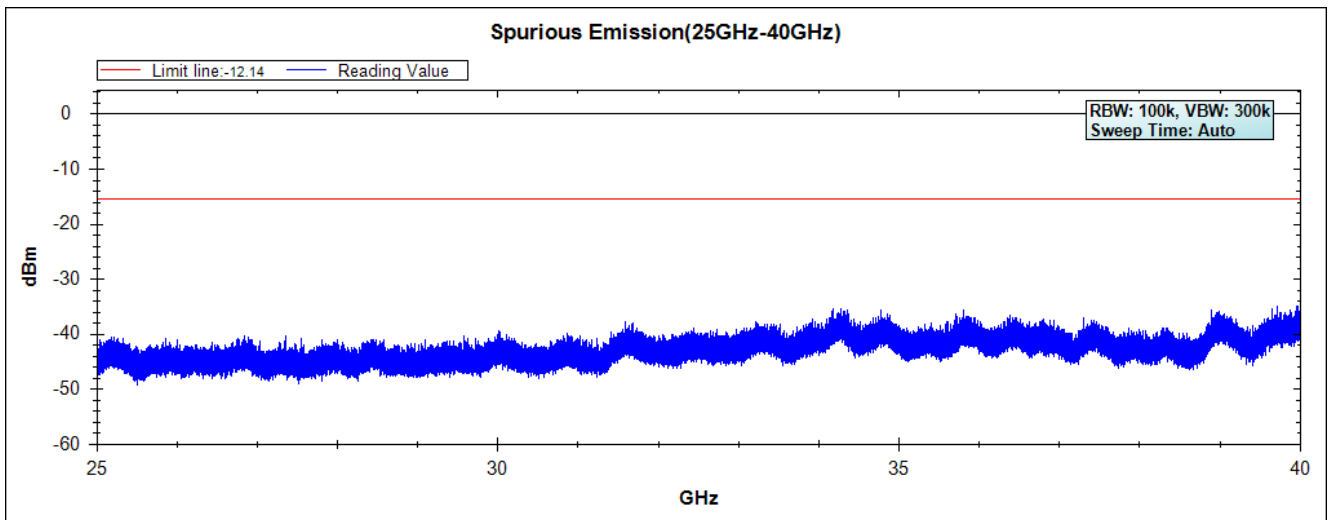
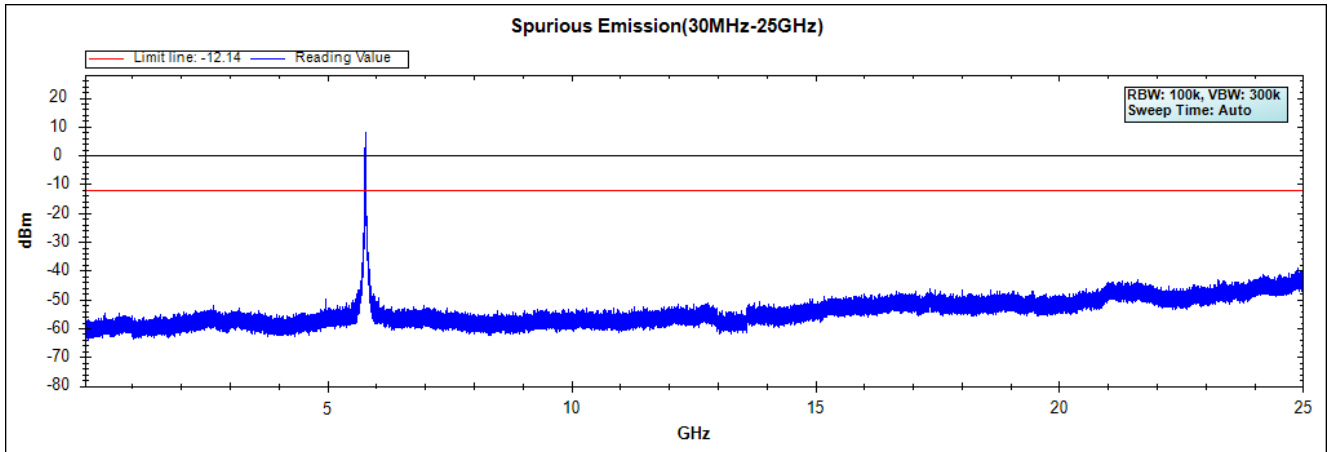

Note: The above test pattern is synthesized by multiple of the frequency range

Channel 165 (5825MHz) 30MHz -40GHz

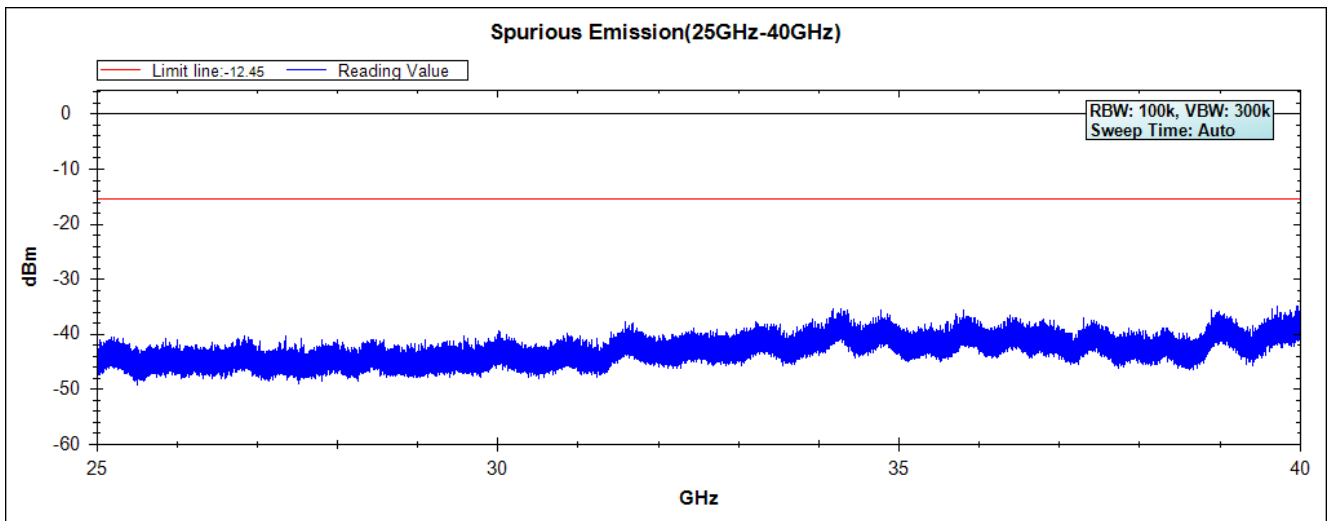
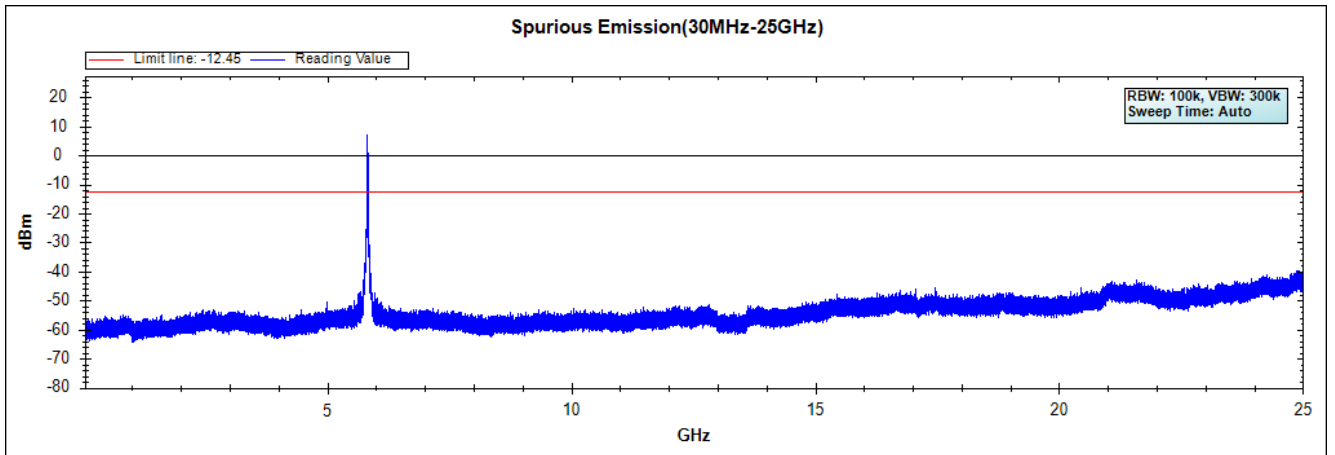

Note: The above test pattern is synthesized by multiple of the frequency range

Product : Intel® Dual Band Wireless-AC 8260  
 Test Item : RF Antenna Conducted Spurious  
 Test Site : No.3 OATS  
 Test Mode : Mode 3 MIMO: Transmit - 802.11n-40BW\_30Mbps(5G Band)

**Chaia B**

**Channel 151 (5755MHz) 30MHz -40GHz**

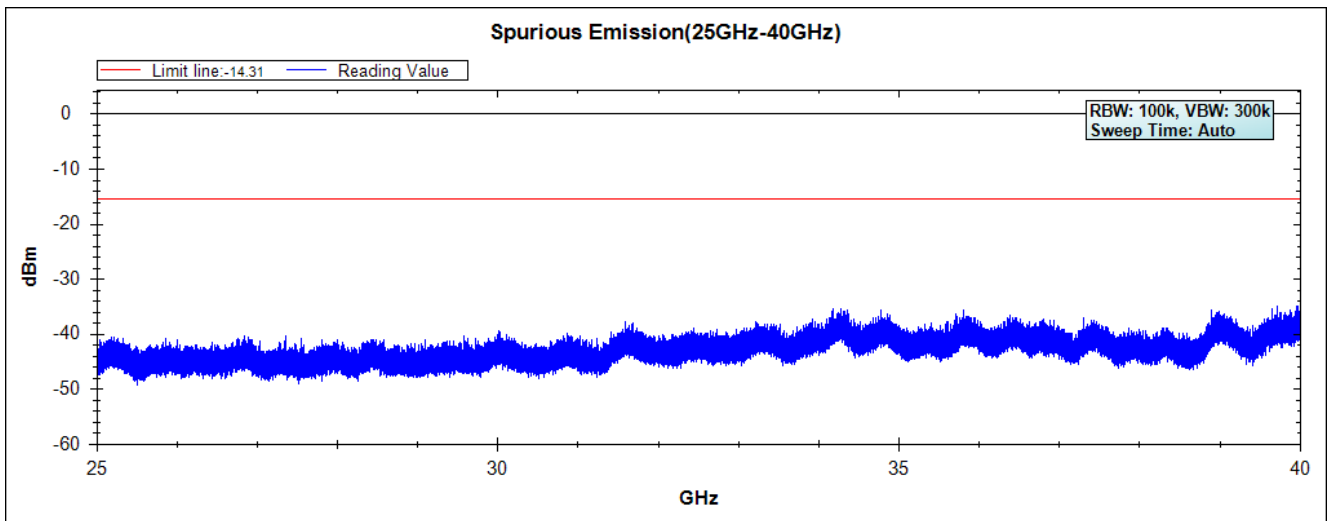
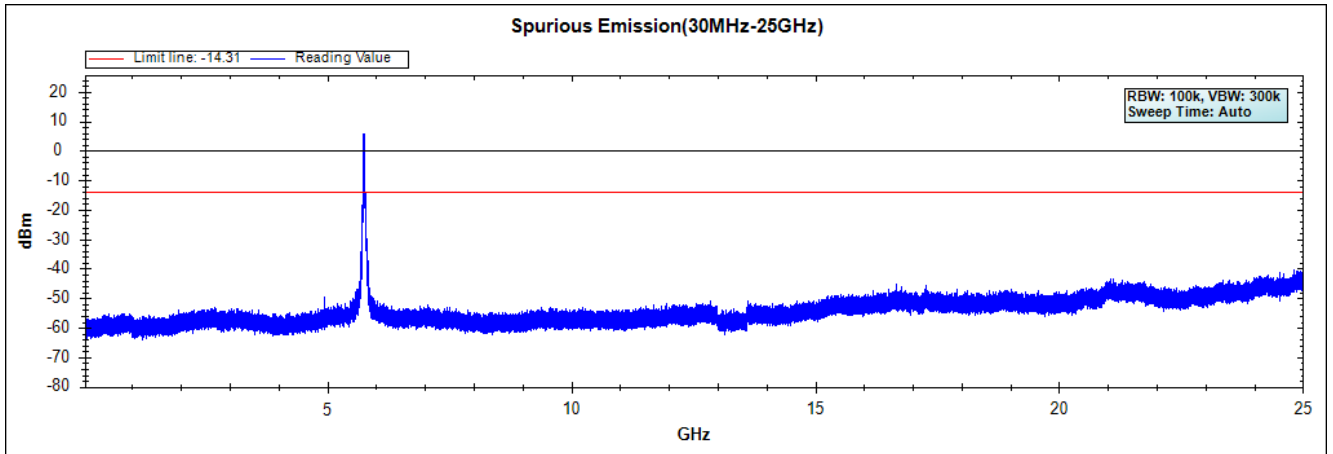

Note: The above test pattern is synthesized by multiple of the frequency range

Channel 159 (5795MHz) 30MHz -40GHz

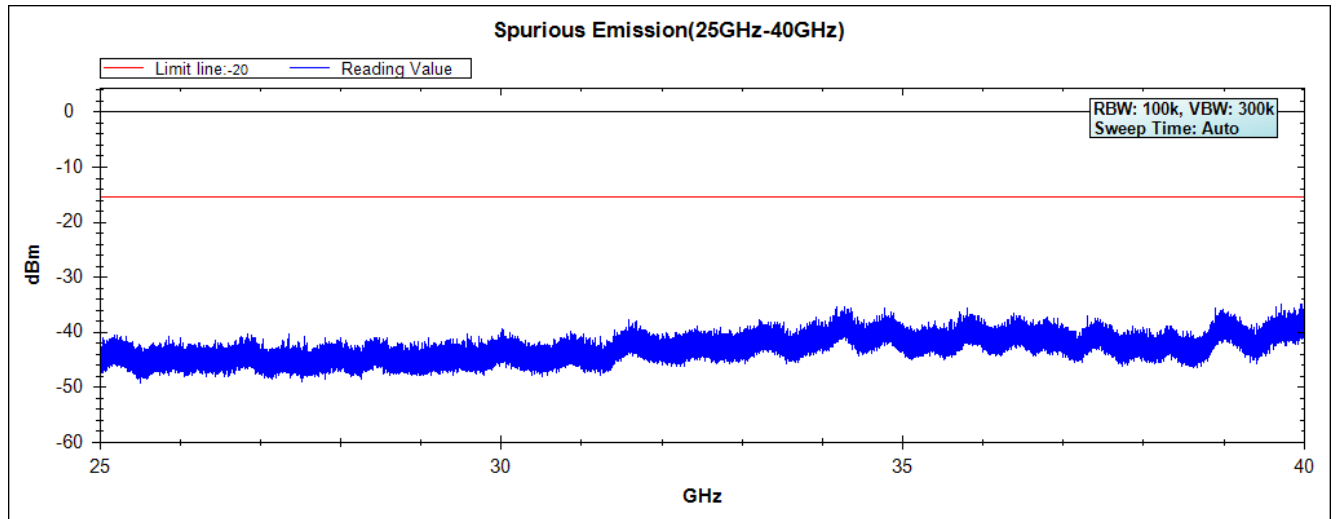
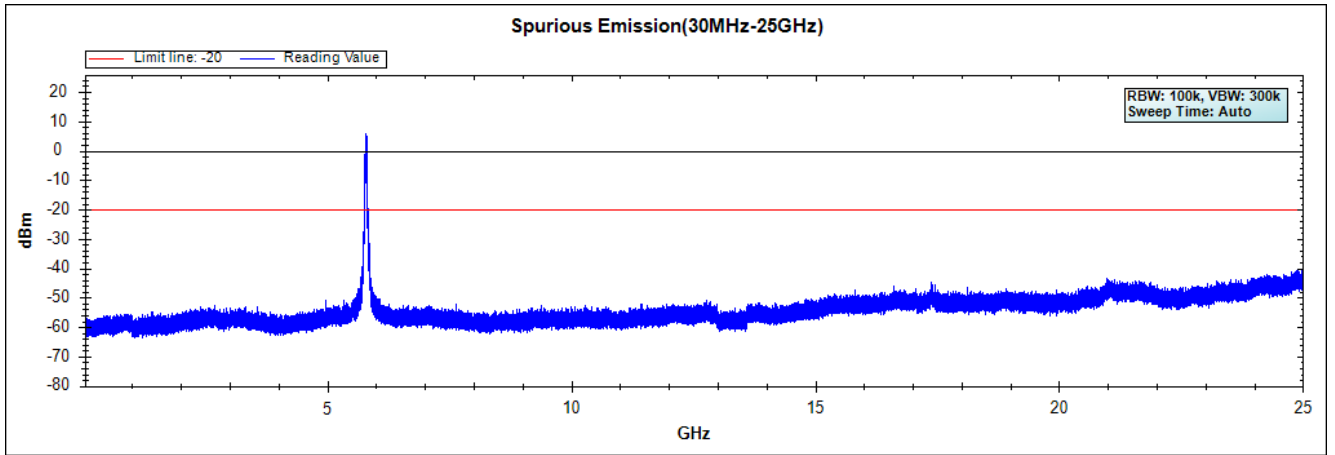

Note: The above test pattern is synthesized by multiple of the frequency range



Product : Intel® Dual Band Wireless-AC 8260  
Test Item : RF Antenna Conducted Spurious  
Test Site : No.3 OATS  
Test Mode : Mode 3 MIMO: Transmit - 802.11ac-80BW\_65Mbps(5G Band)

**Chaia B**

**Channel 155 (5775MHz) 30MHz -40GHz**

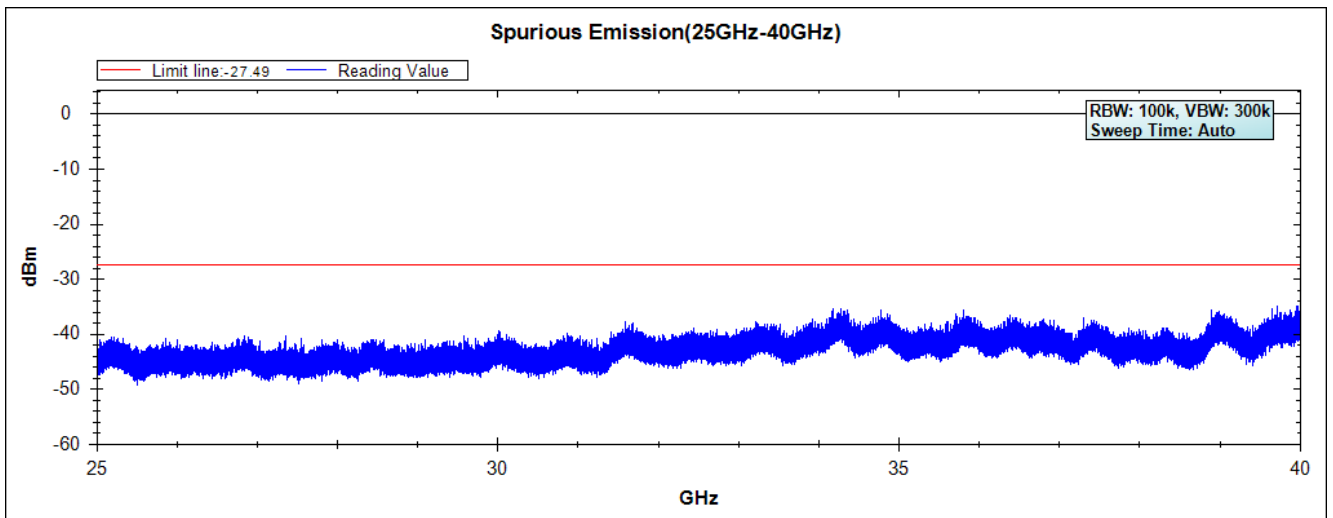
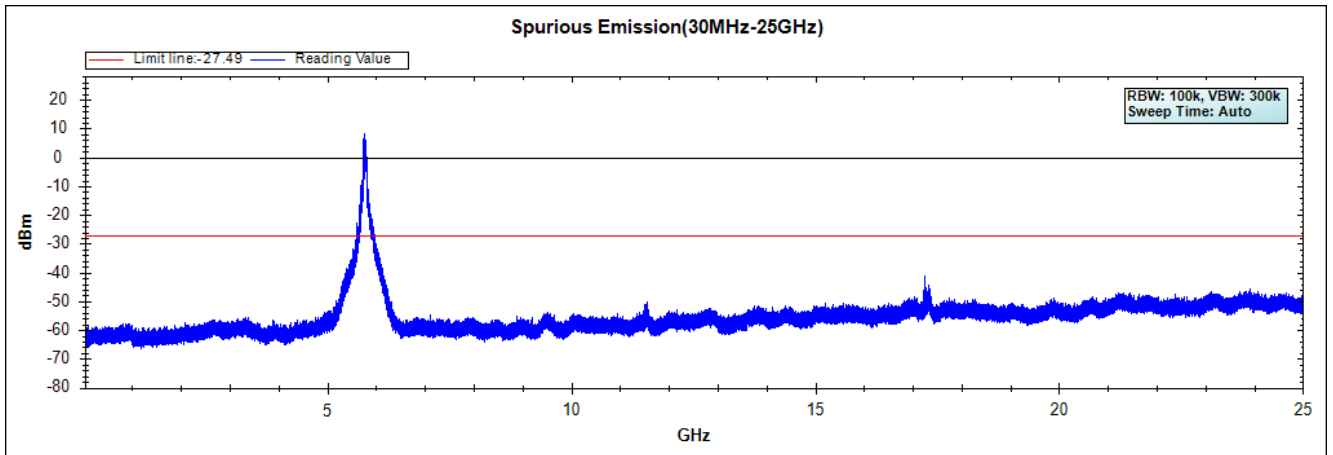

Note: The above test pattern is synthesized by multiple of the frequency range

Product : Intel® Dual Band Wireless-AC 8260  
Test Item : RF Antenna Conducted Spurious  
Test Site : No.3 OATS  
Test Mode : Mode 4 Beamforming: Transmit - 802.11n-20BW\_14.4Mbps(2.4G Band)

Chaia A

Channel 01 (2412MHz) 30MHz -25GHz

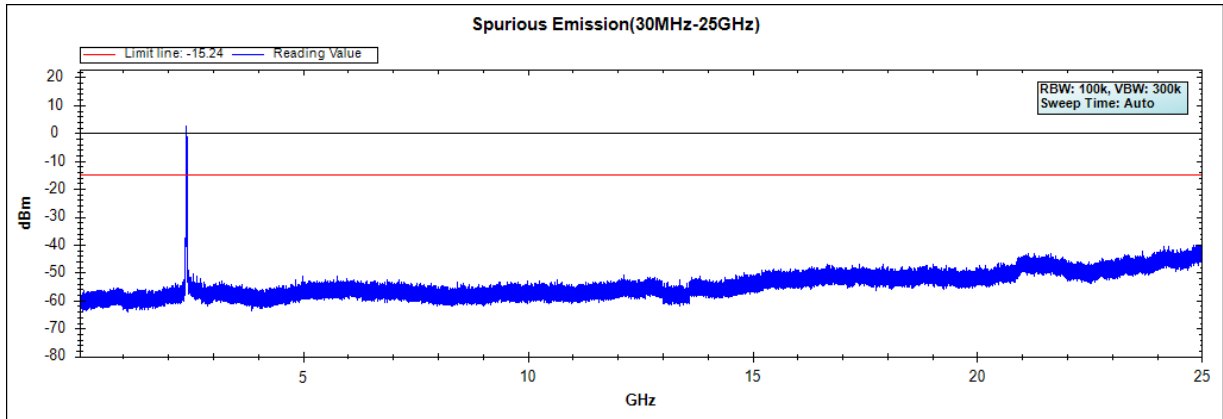

Channel 06 (2437MHz) 30MHz -25GHz

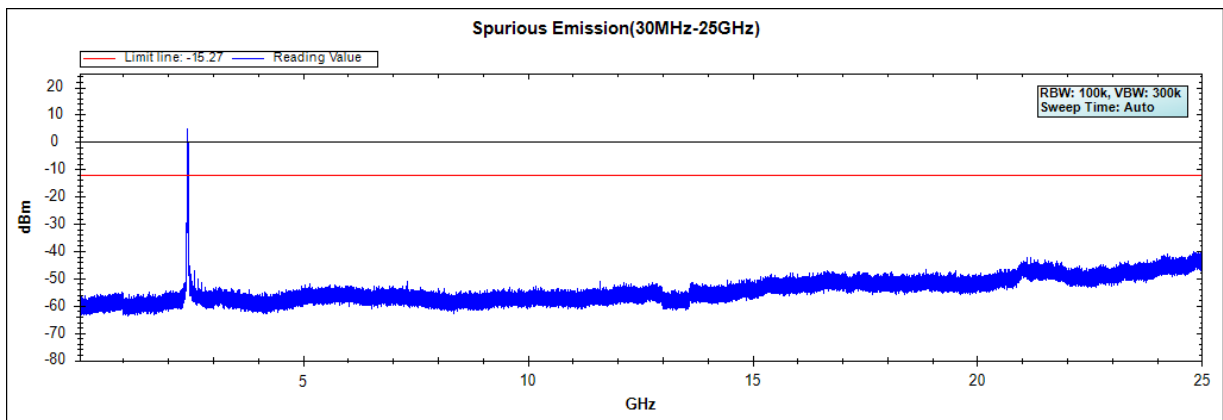

**Channel 11 (2462MHz) 30MHz -25GHz**

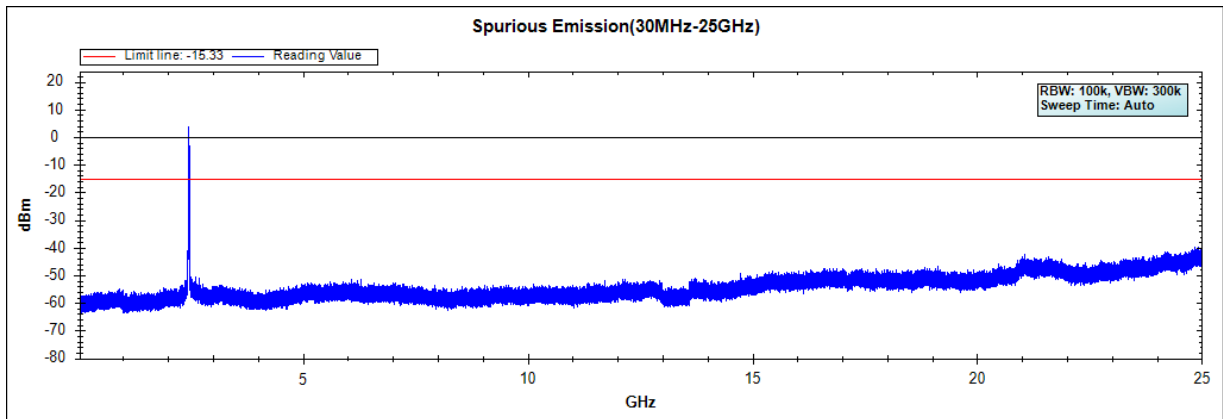

**Channel 12 (2467MHz) 30MHz -25GHz**

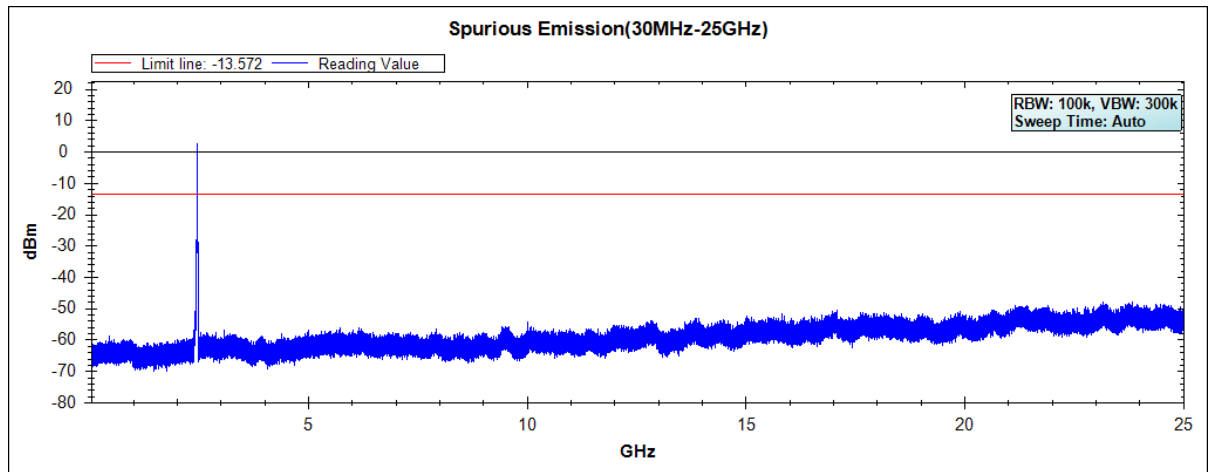

Note: The above test pattern is synthesized by multiple of the frequency range.

Product : Intel® Dual Band Wireless-AC 8260  
Test Item : RF Antenna Conducted Spurious  
Test Site : No.3 OATS  
Test Mode : Mode 4 Beamforming: Transmit - 802.11n-40BW\_30Mbps(2.4G Band)

**Chaia A**

**Channel 03 (2422MHz) 30MHz -25GHz**

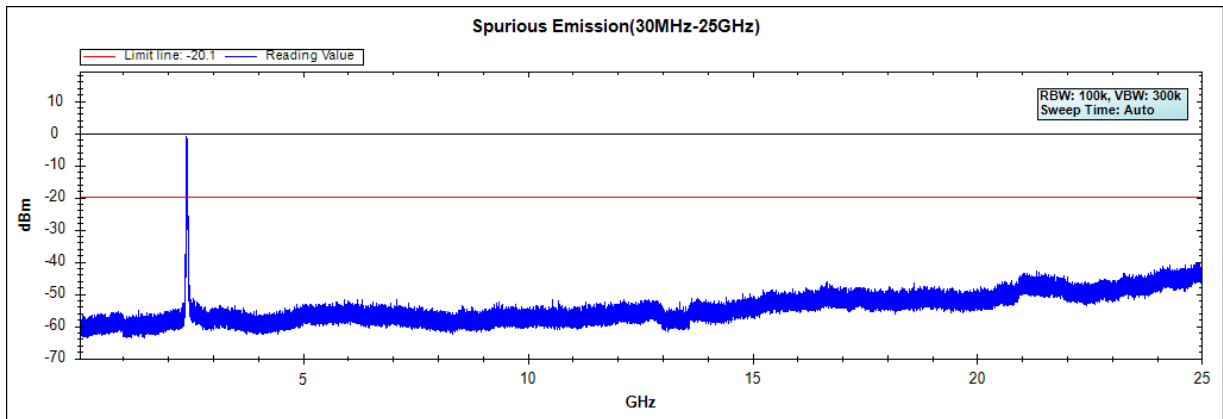

**Channel 06 (2437MHz) 30MHz -25GHz**

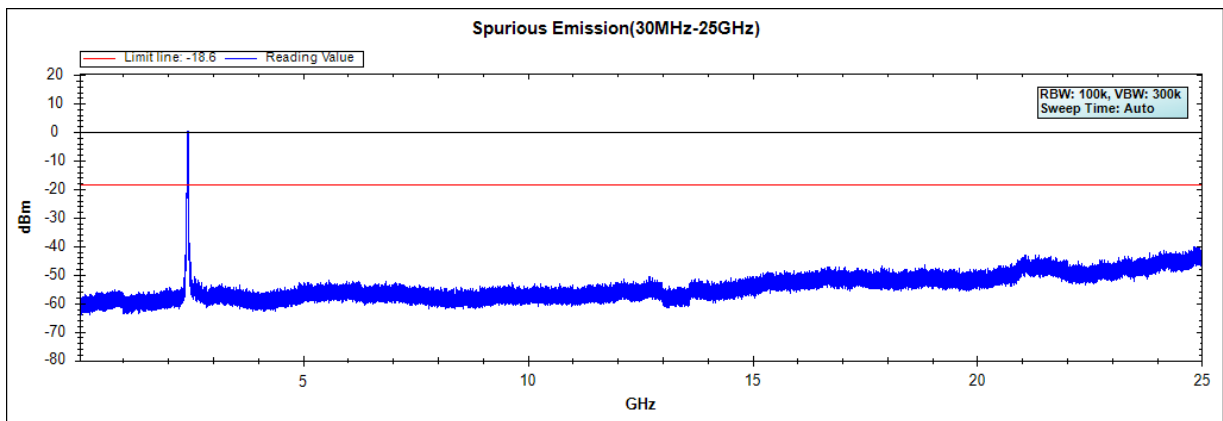

**Channel 09 (2452MHz) 30MHz -25GHz**

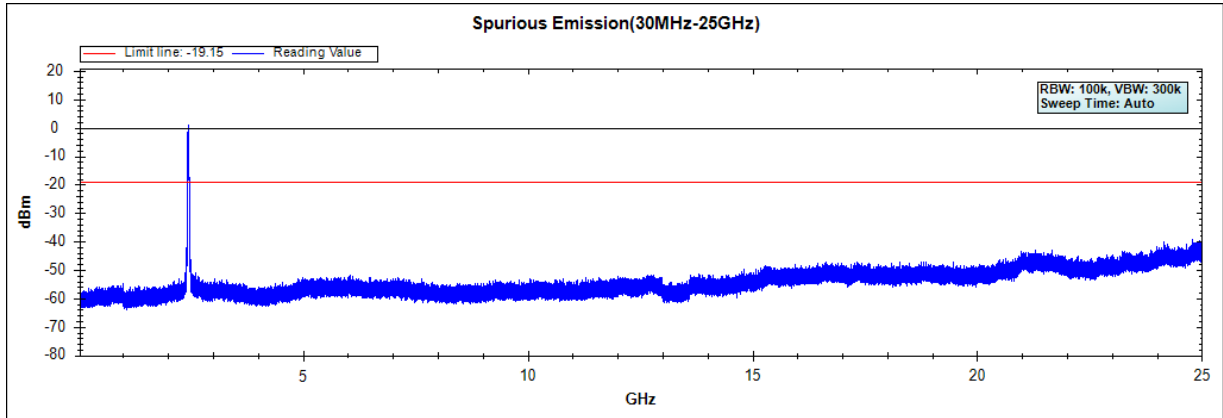

**Channel 10 (2457MHz) 30MHz -25GHz**

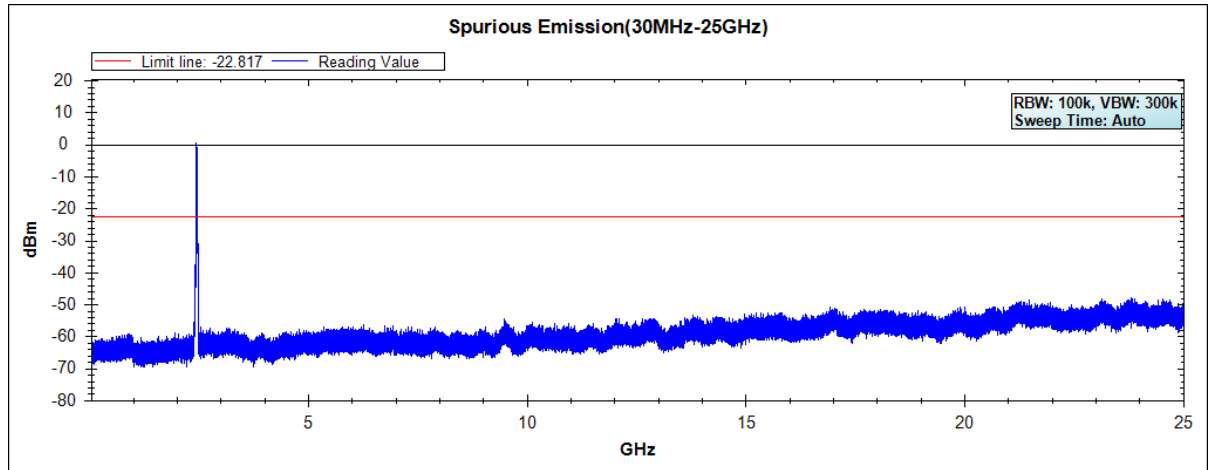

Note: The above test pattern is synthesized by multiple of the frequency range.

Product : Intel® Dual Band Wireless-AC 8260  
 Test Item : RF Antenna Conducted Spurious  
 Test Site : No.3 OATS  
 Test Mode : Mode 4 Beamforming: Transmit - 802.11n-20BW\_14.4Mbps(5G Band)

**Chaia A**

**Channel 49 (5745MHz) 30MHz -40GHz**

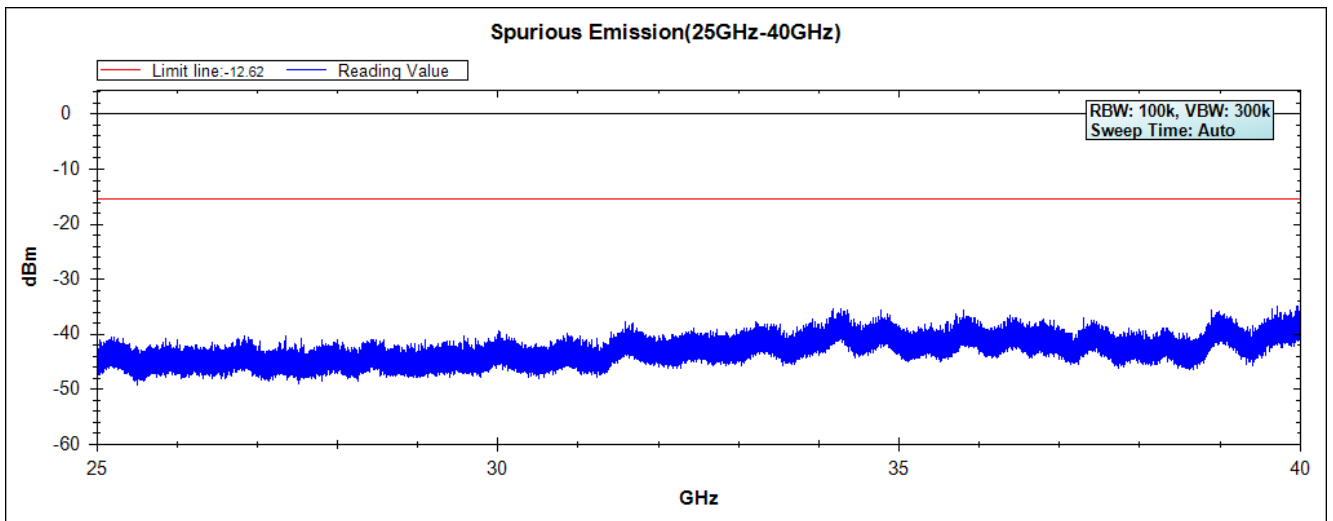
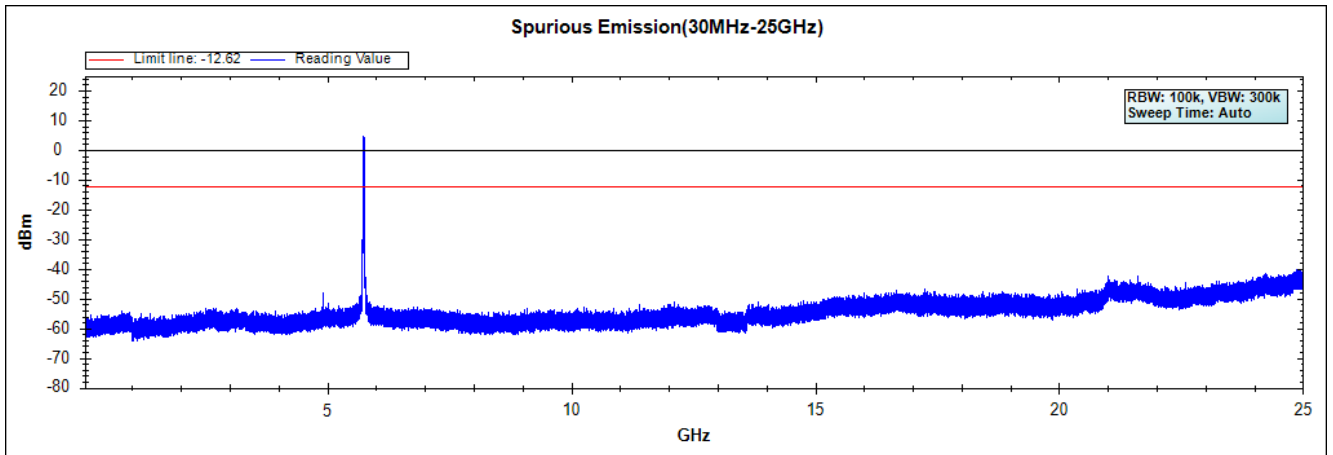

Note: The above test pattern is synthesized by multiple of the frequency range

**Channel 157 (5785MHz) 30MHz -40GHz**

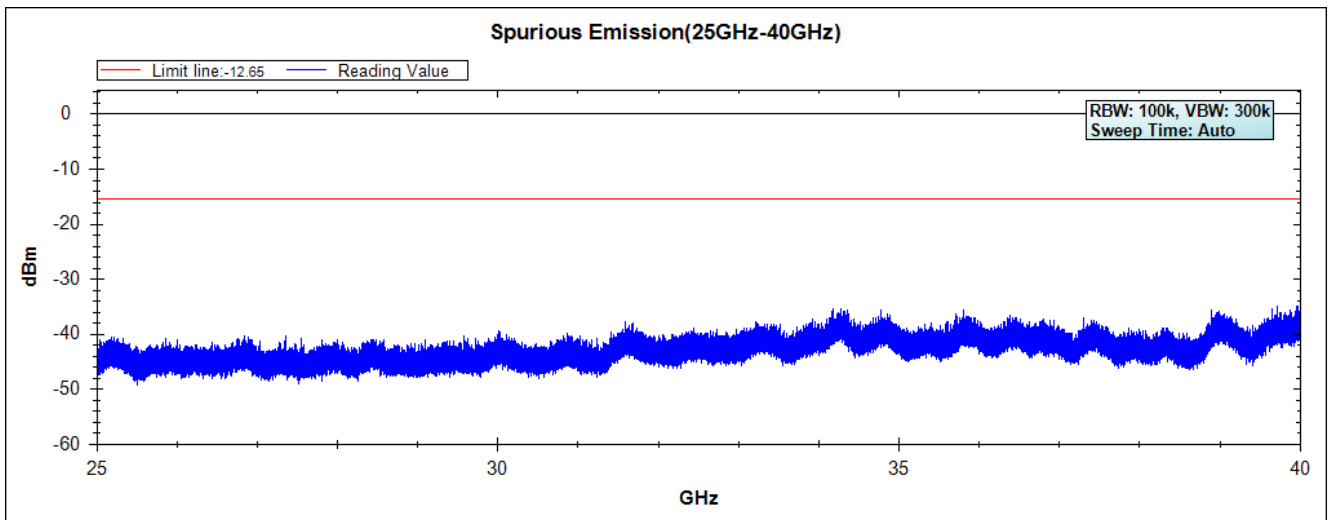
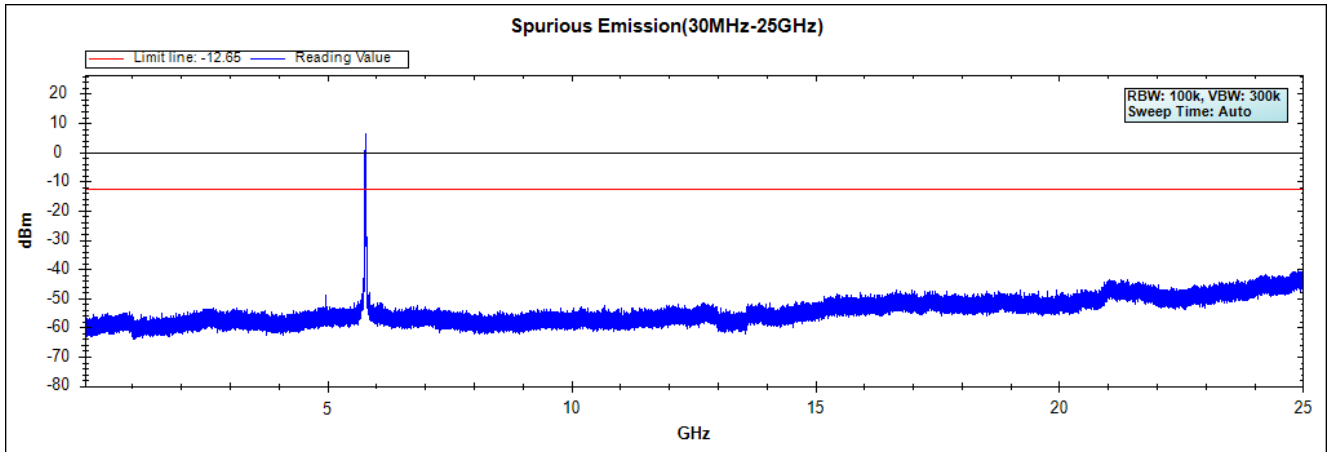

Note: The above test pattern is synthesized by multiple of the frequency range

Channel 165 (5825MHz) 30MHz -40GHz

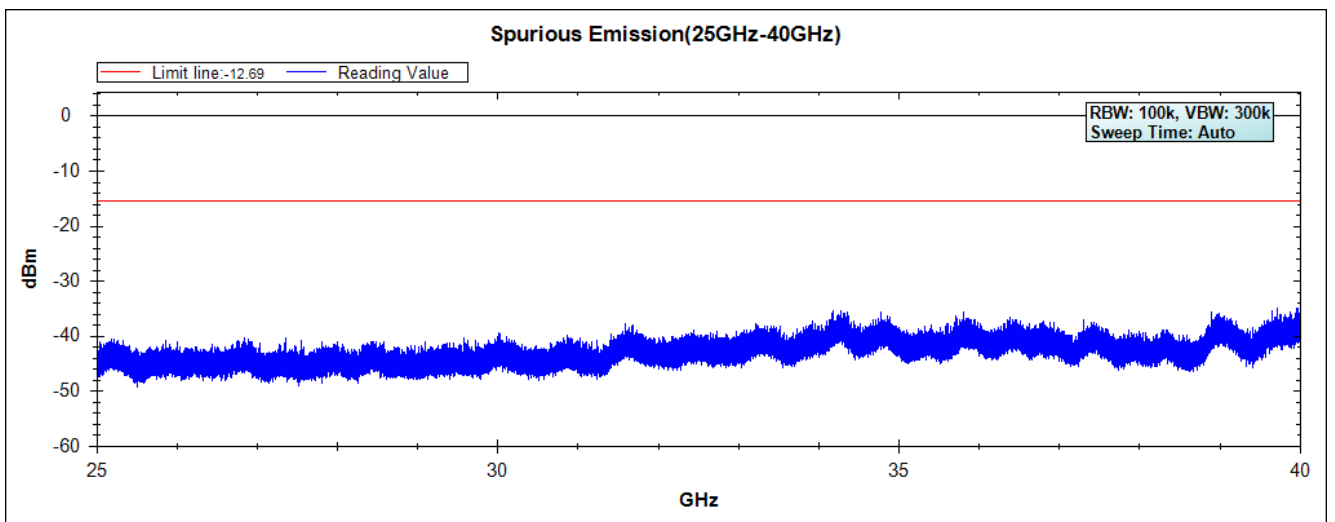
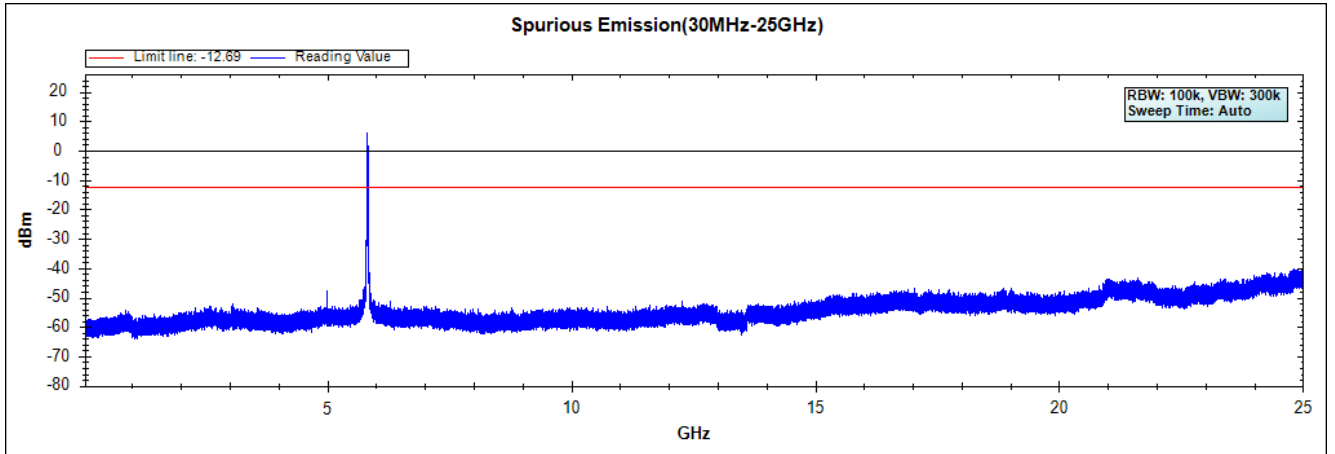

Note: The above test pattern is synthesized by multiple of the frequency range



Product : Intel® Dual Band Wireless-AC 8260  
Test Item : RF Antenna Conducted Spurious  
Test Site : No.3 OATS  
Test Mode : Mode 4 Beamforming: Transmit - 802.11n-40BW\_30Mbps(5G Band)

**Chaia A**

**Channel 151 (5755MHz) 30MHz -40GHz**

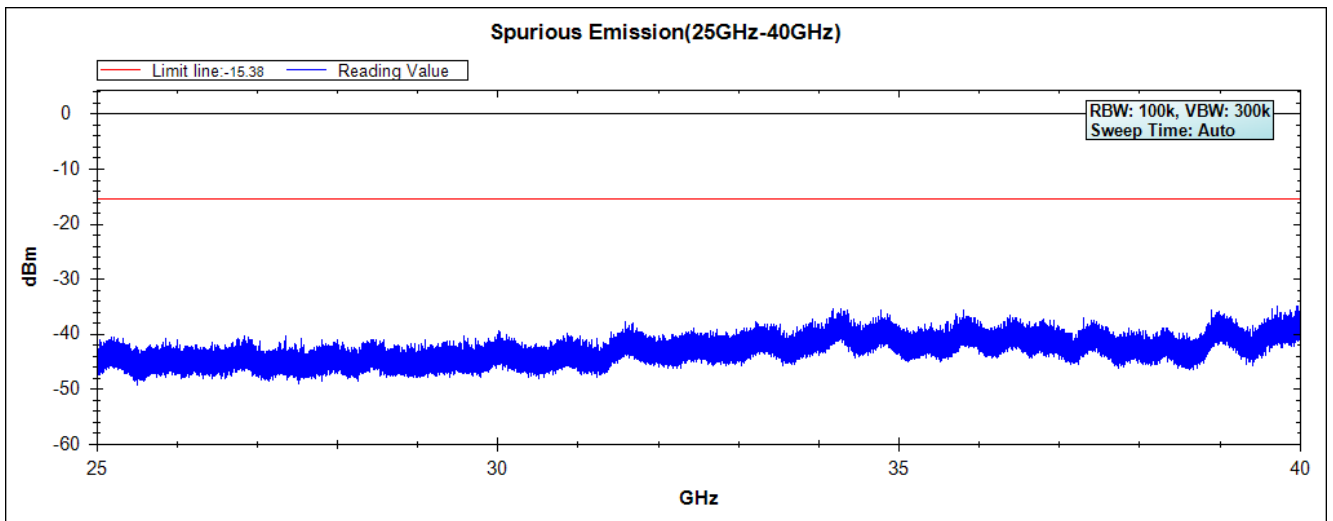
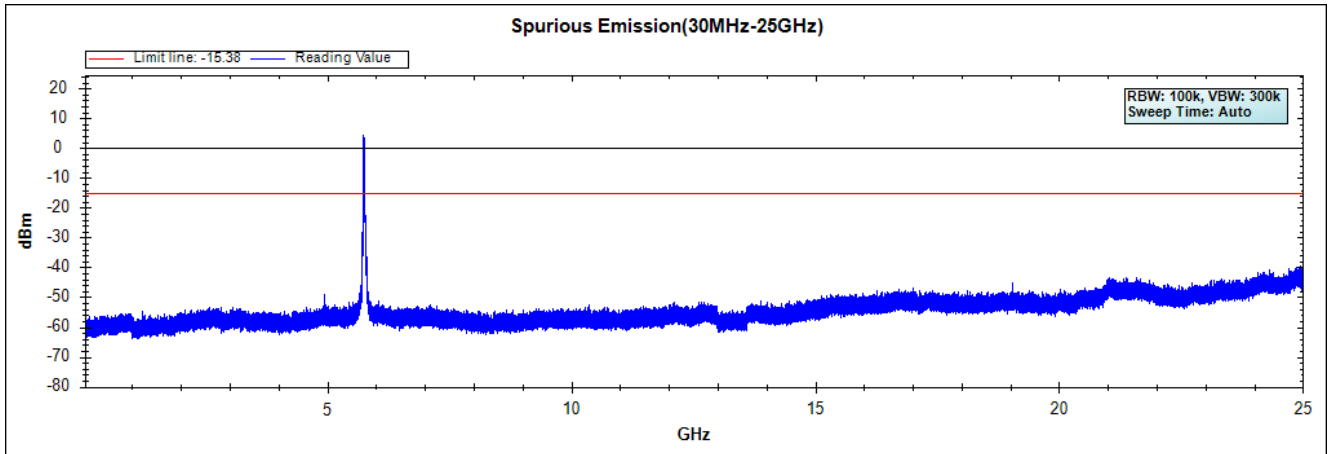

Note: The above test pattern is synthesized by multiple of the frequency range

Channel 159 (5795MHz) 30MHz -40GHz

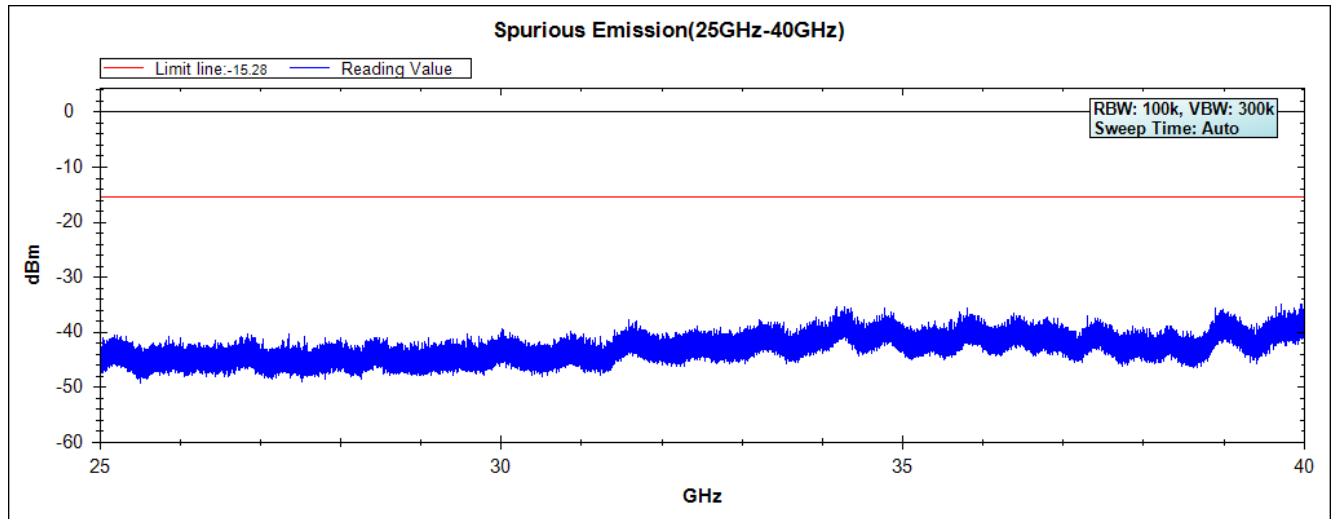
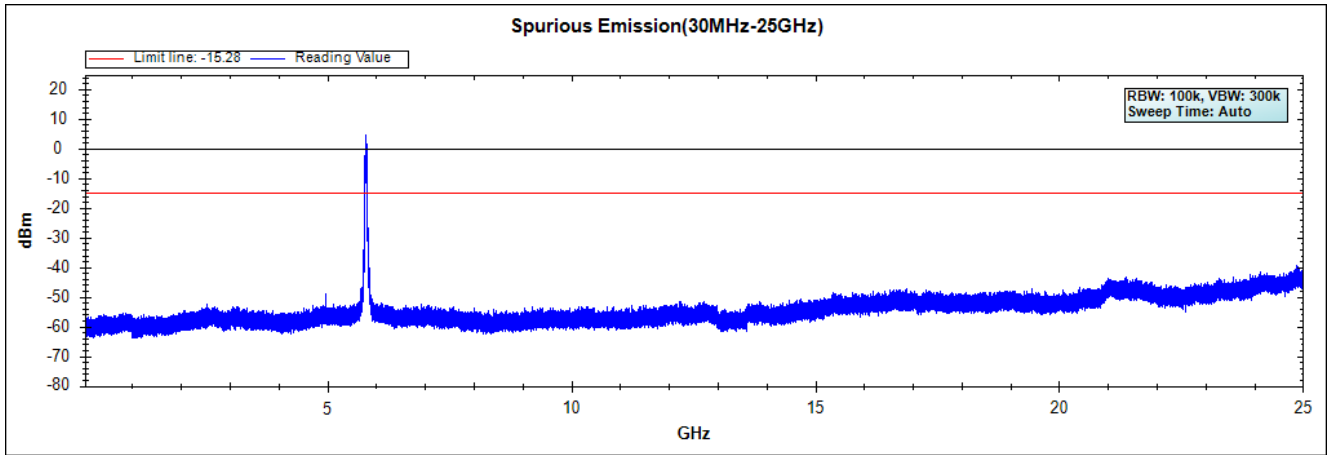

Note: The above test pattern is synthesized by multiple of the frequency range

Product : Intel® Dual Band Wireless-AC 8260  
 Test Item : RF Antenna Conducted Spurious  
 Test Site : No.3 OATS  
 Test Mode : Mode 4 Beamforming: Transmit - 802.11ac-80BW\_65Mbps(5G Band)

**Chaia A**

**Channel 155 (5775MHz) 30MHz -40GHz**

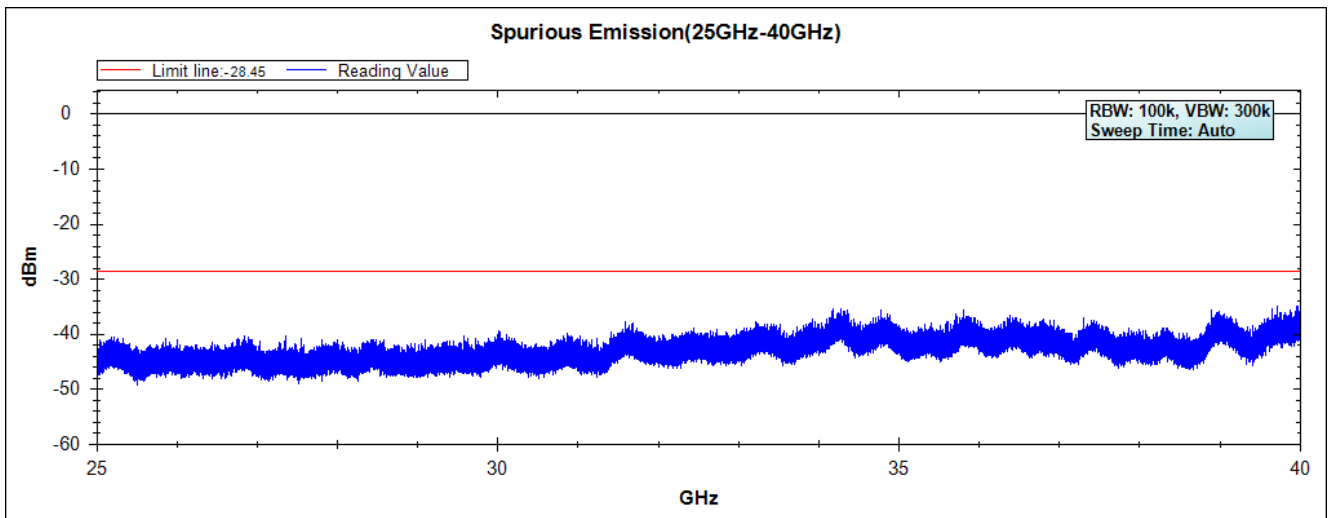
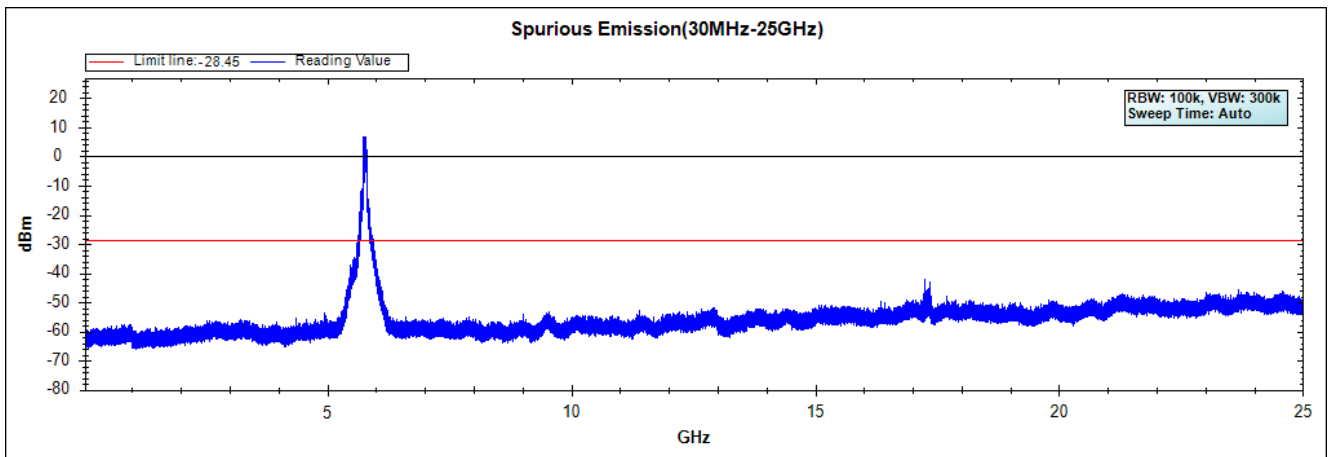

Note: The above test pattern is synthesized by multiple of the frequency range

Product : Intel® Dual Band Wireless-AC 8260  
Test Item : RF Antenna Conducted Spurious  
Test Site : No.3 OATS  
Test Mode : Mode 4 Beamforming: Transmit - 802.11n-20BW\_14.4Mbps(2.4G Band)

**Chaia B**

**Channel 01 (2412MHz) 30MHz -25GHz**

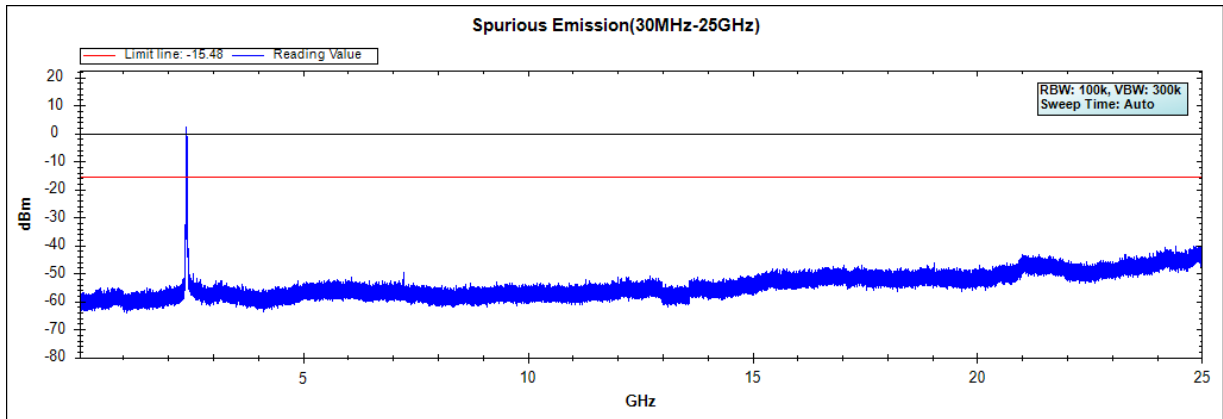

**Channel 06 (2437MHz) 30MHz -25GHz**

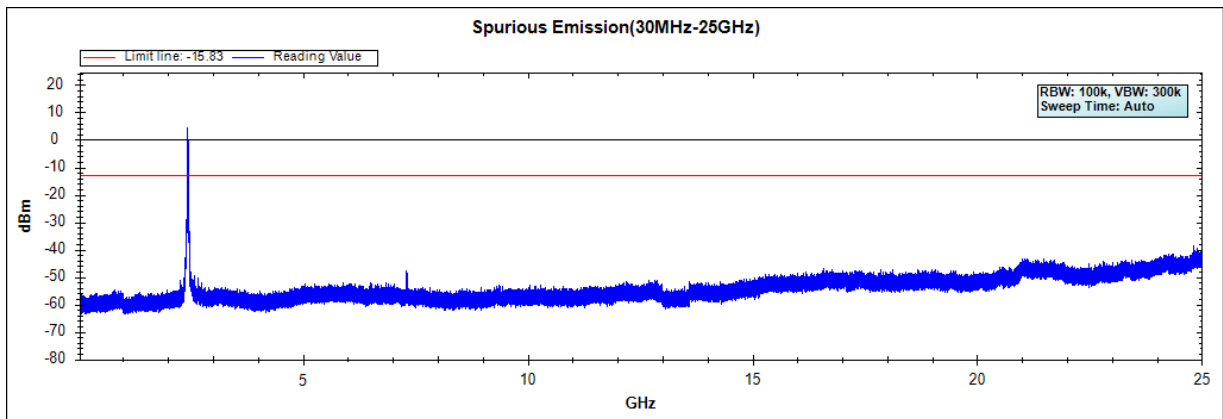

**Channel 11 (2462MHz) 30MHz -25GHz**

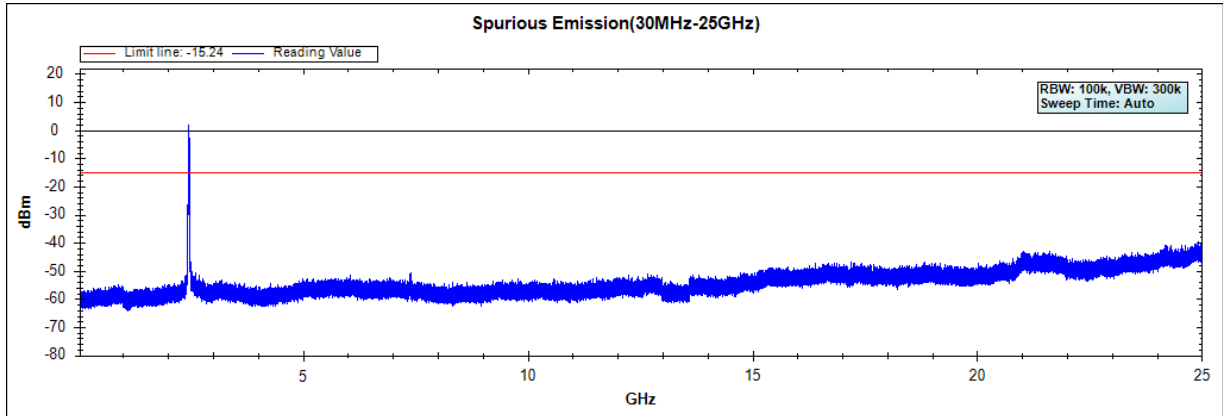

**Channel 12 (2467MHz) 30MHz -25GHz**

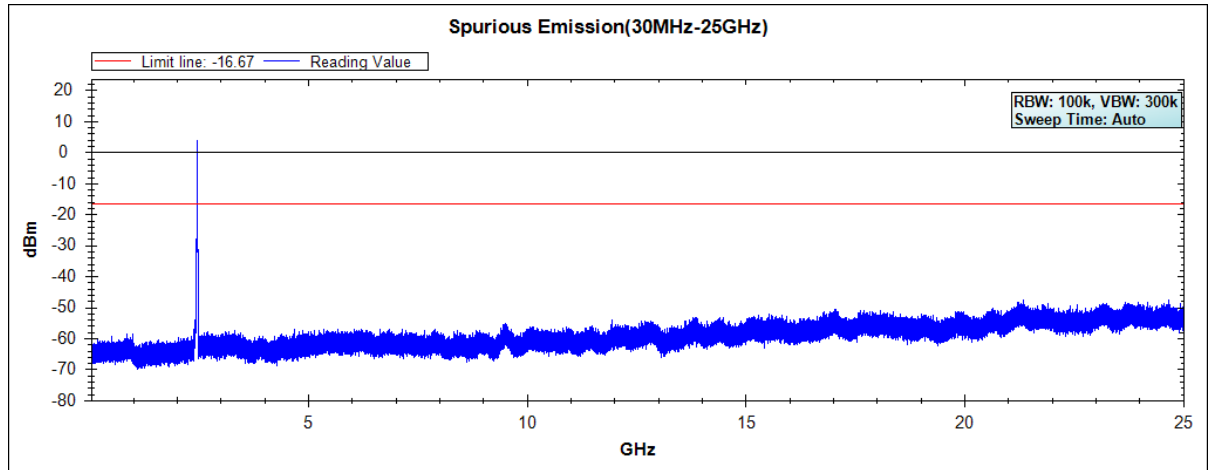

Note: The above test pattern is synthesized by multiple of the frequency range.

Product : Intel® Dual Band Wireless-AC 8260  
 Test Item : RF Antenna Conducted Spurious  
 Test Site : No.3 OATS  
 Test Mode : Mode 4 Beamforming: Transmit - 802.11n-40BW\_30Mbps(2.4G Band)

**Chaia B**

**Channel 03 (2422MHz) 30MHz -25GHz**

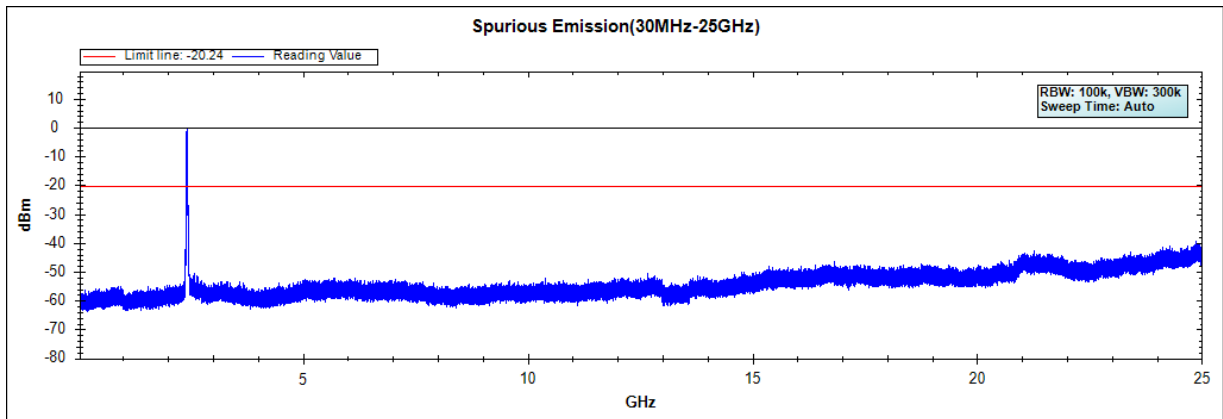

**Channel 06 (2437MHz) 30MHz -25GHz**

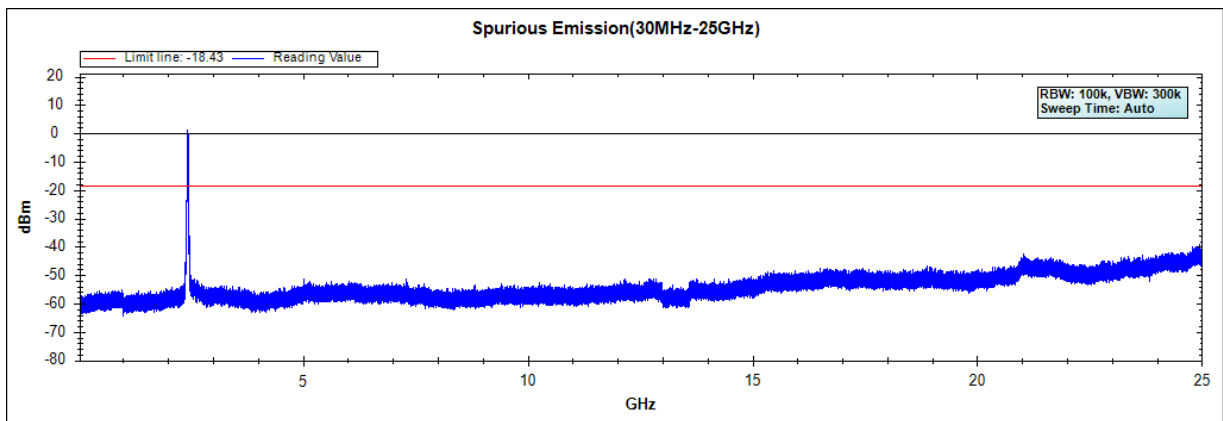

**Channel 09 (2452MHz) 30MHz -25GHz**

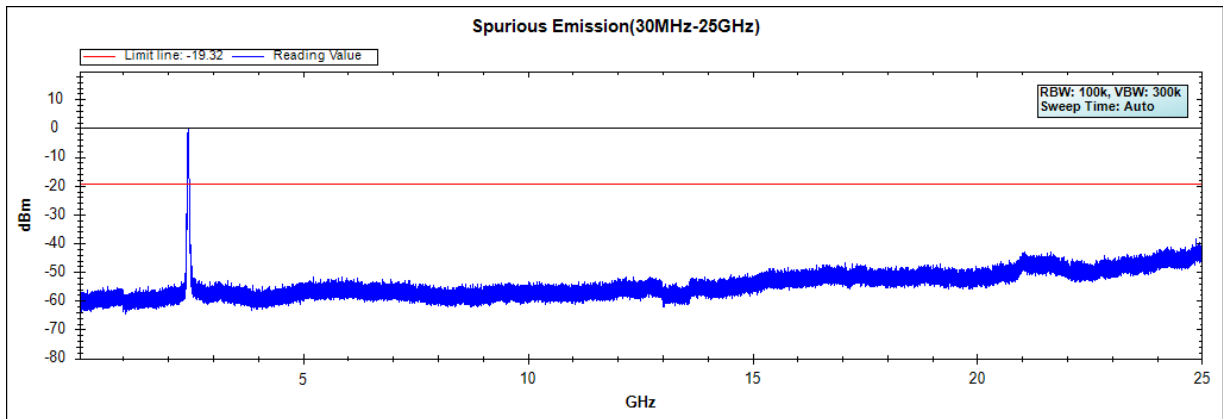

**Channel 10 (2457MHz) 30MHz -25GHz**

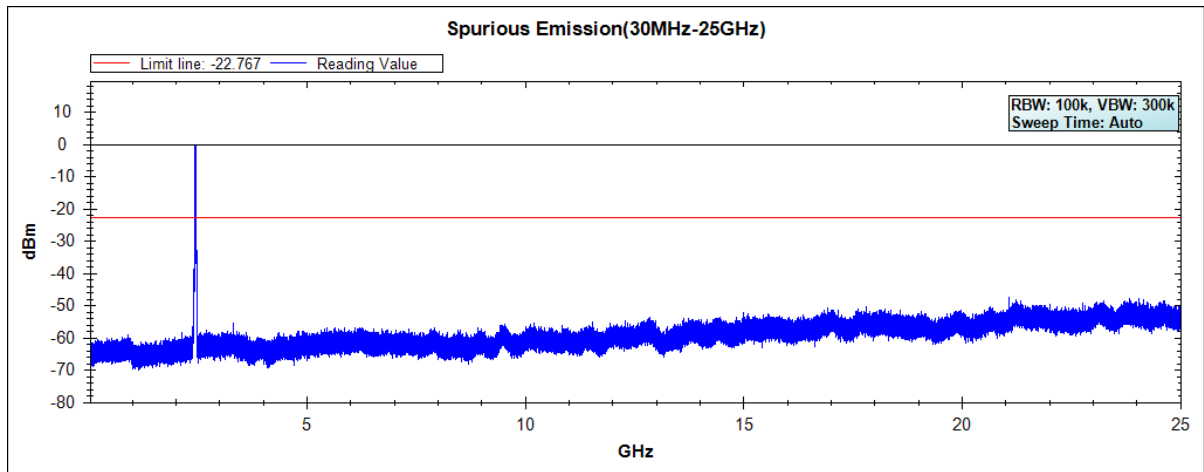

Note: The above test pattern is synthesized by multiple of the frequency range.

Product : Intel® Dual Band Wireless-AC 8260  
Test Item : RF Antenna Conducted Spurious  
Test Site : No.3 OATS  
Test Mode : Mode 4 Beamforming: Transmit - 802.11n-20BW\_14.4Mbps(5G Band)

**Chaia B**

**Channel 49 (5745MHz) 30MHz -40GHz**

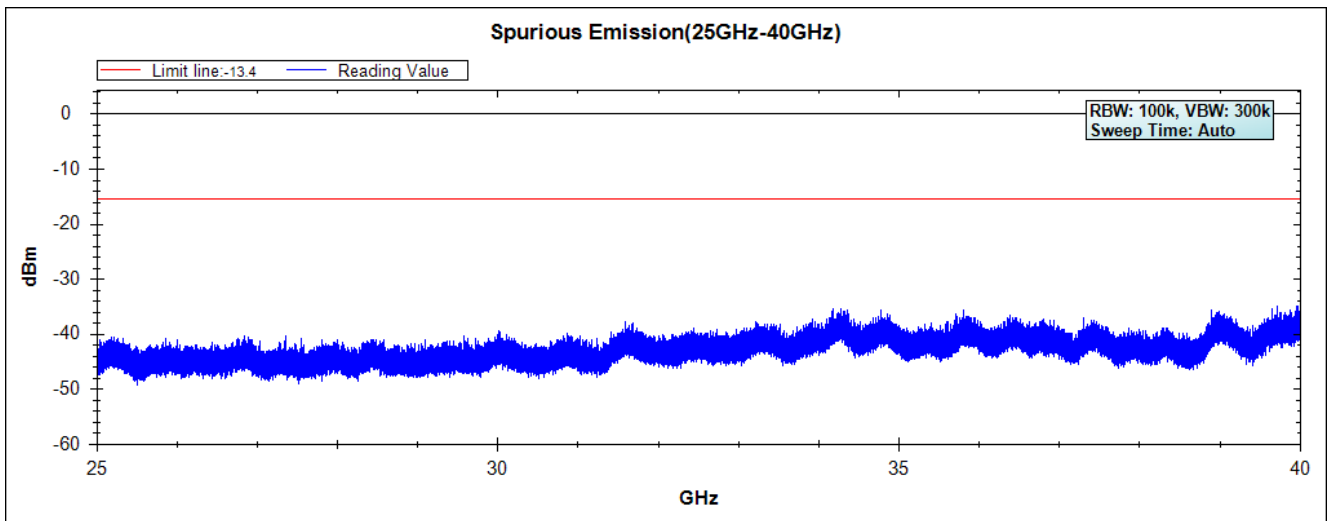
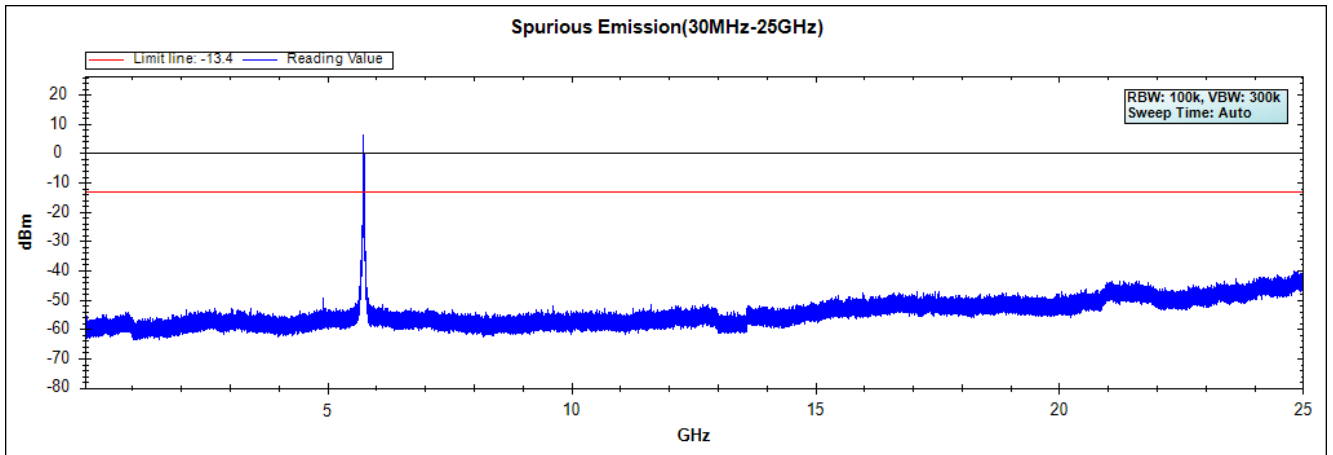

Note: The above test pattern is synthesized by multiple of the frequency range



Channel 157 (5785MHz) 30MHz -40GHz

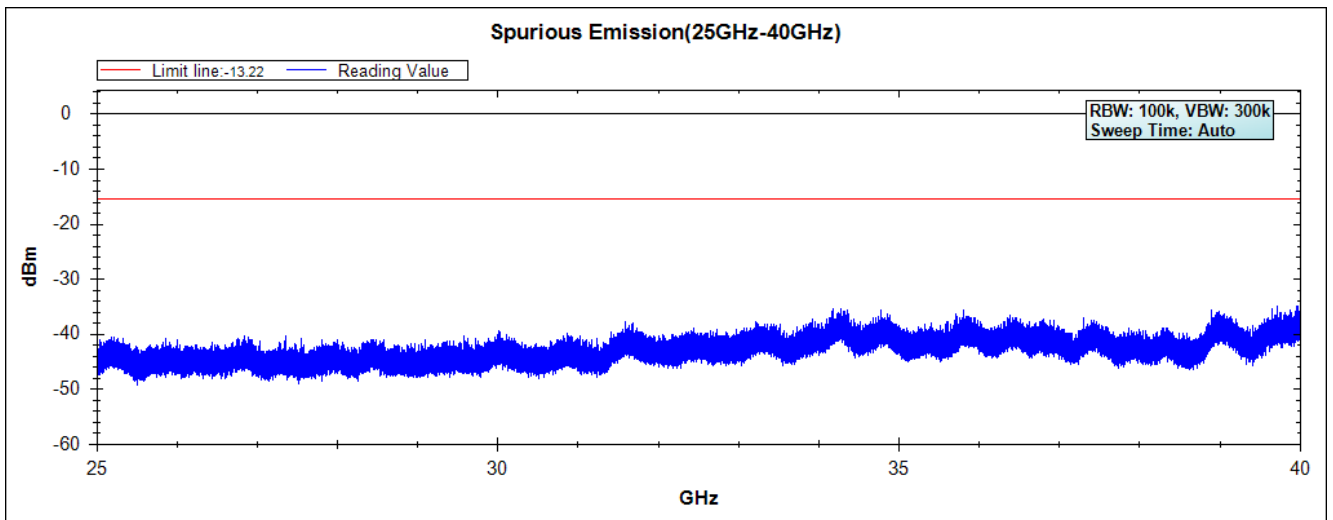
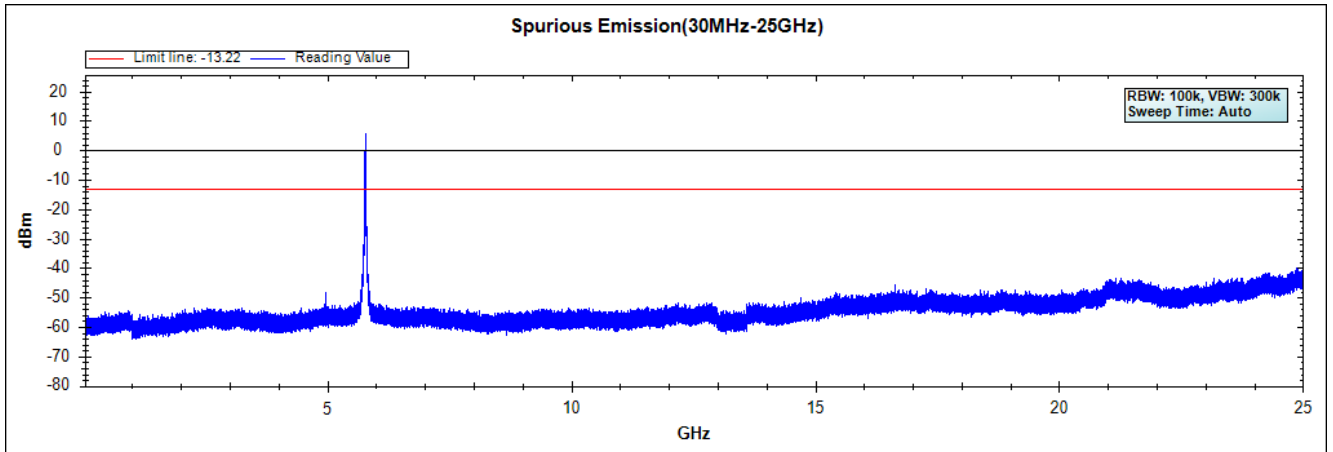

Note: The above test pattern is synthesized by multiple of the frequency range

Channel 165 (5825MHz) 30MHz -40GHz

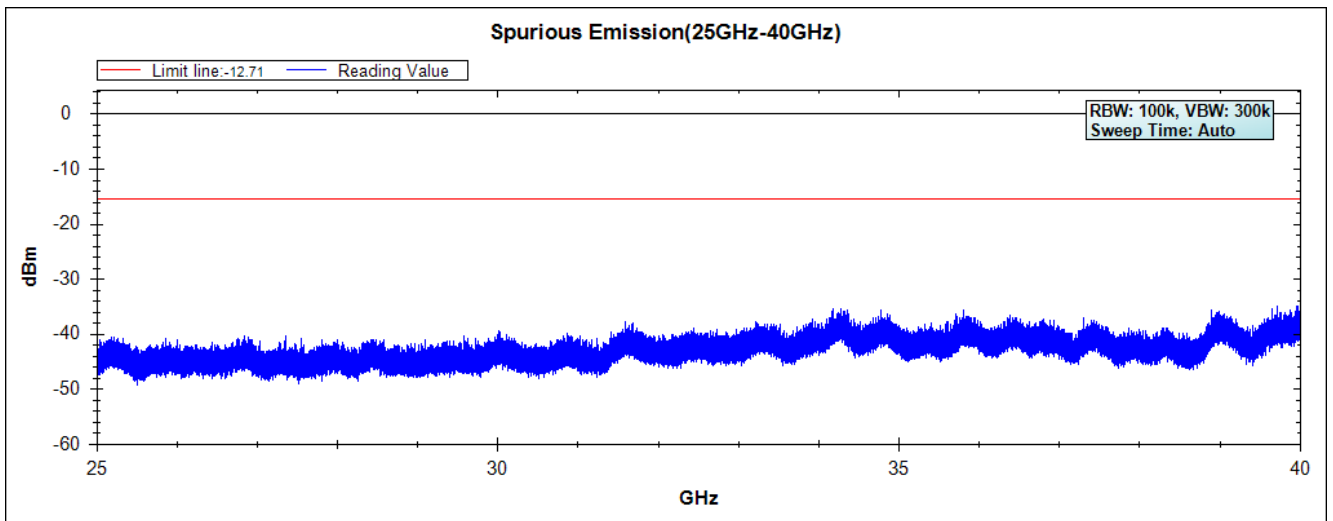
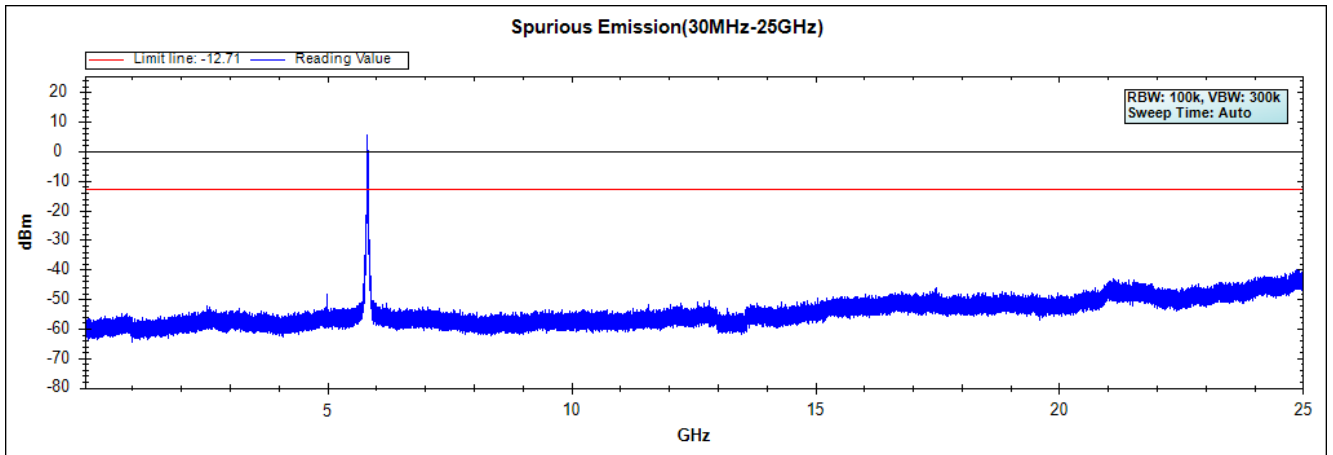

Note: The above test pattern is synthesized by multiple of the frequency range

Product : Intel® Dual Band Wireless-AC 8260  
Test Item : RF Antenna Conducted Spurious  
Test Site : No.3 OATS  
Test Mode : Mode 4 Beamforming: Transmit - 802.11n-40BW\_30Mbps(5G Band)

**Chaia B**

**Channel 151 (5755MHz) 30MHz -40GHz**

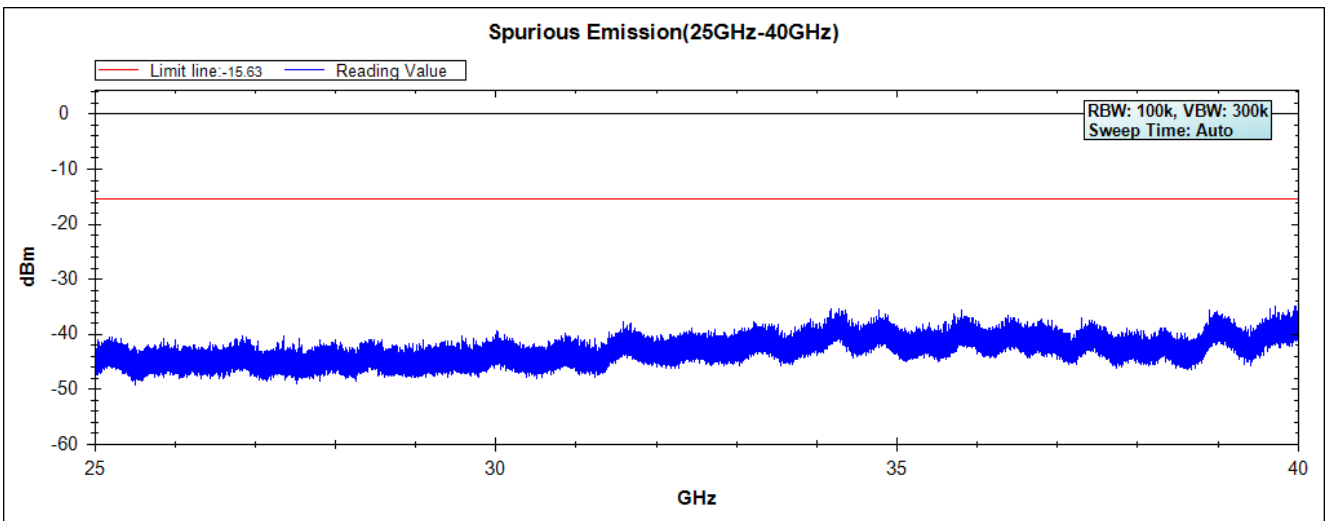
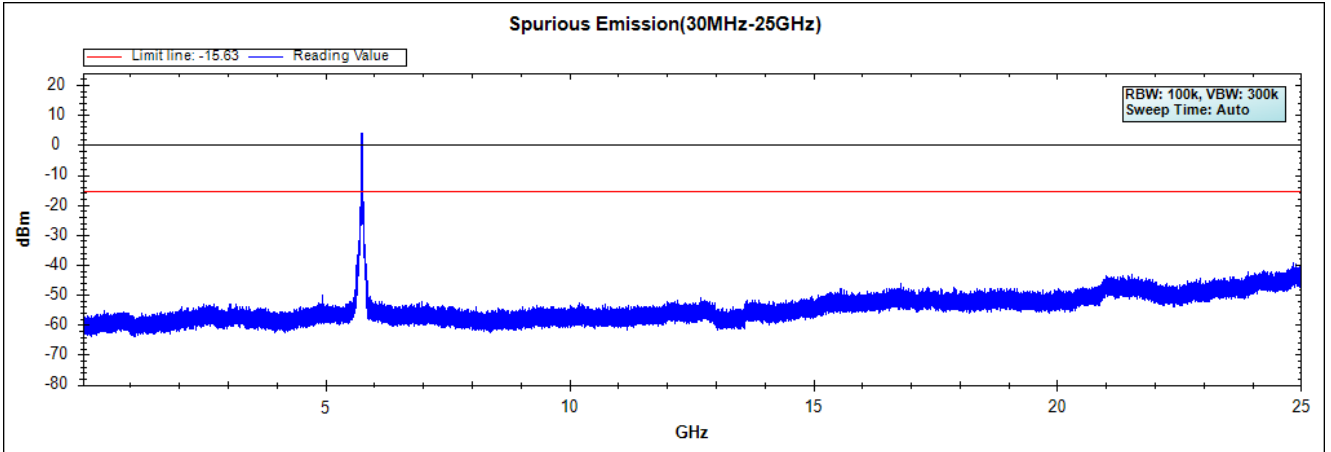

Note: The above test pattern is synthesized by multiple of the frequency range

Channel 159 (5795MHz) 30MHz -40GHz

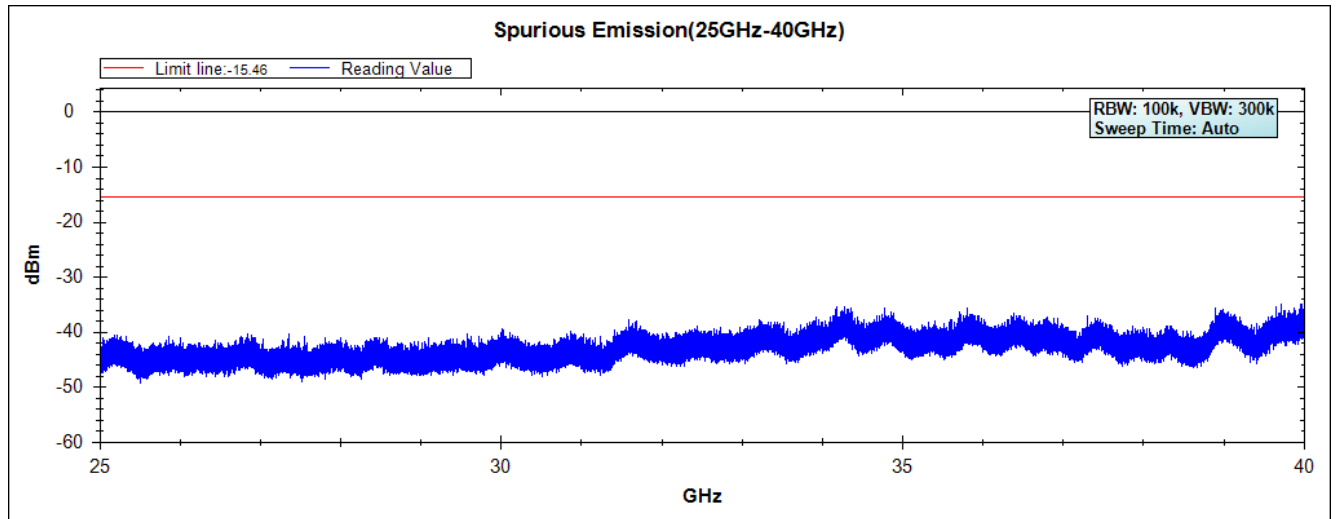
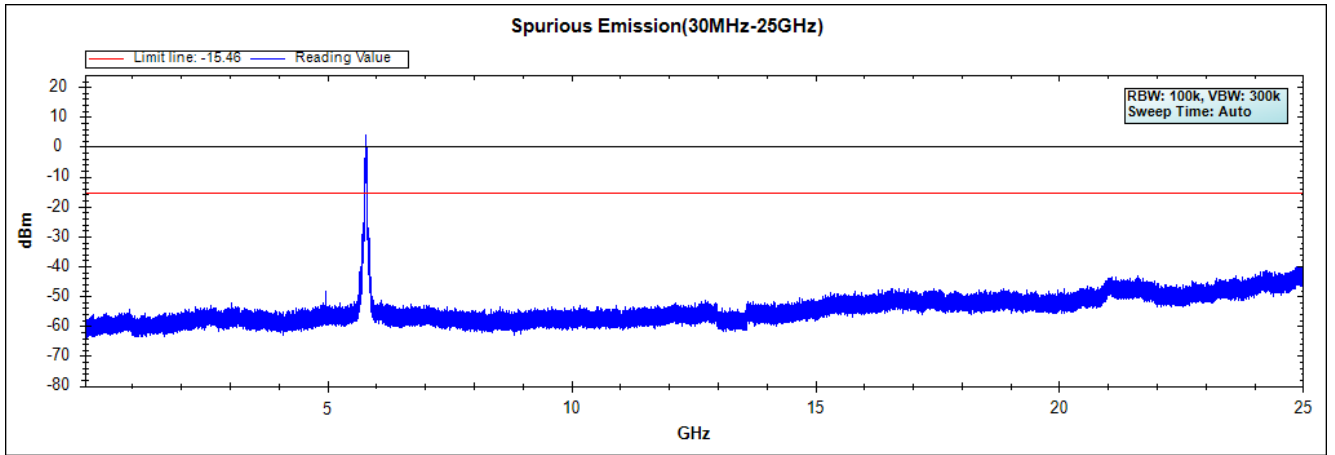

Note: The above test pattern is synthesized by multiple of the frequency range

Product : Intel® Dual Band Wireless-AC 8260  
Test Item : RF Antenna Conducted Spurious  
Test Site : No.3 OATS  
Test Mode : Mode 4 Beamforming: Transmit - 802.11ac-80BW\_65Mbps(5G Band)

**Chaia B**

**Channel 155 (5775MHz) 30MHz -40GHz**

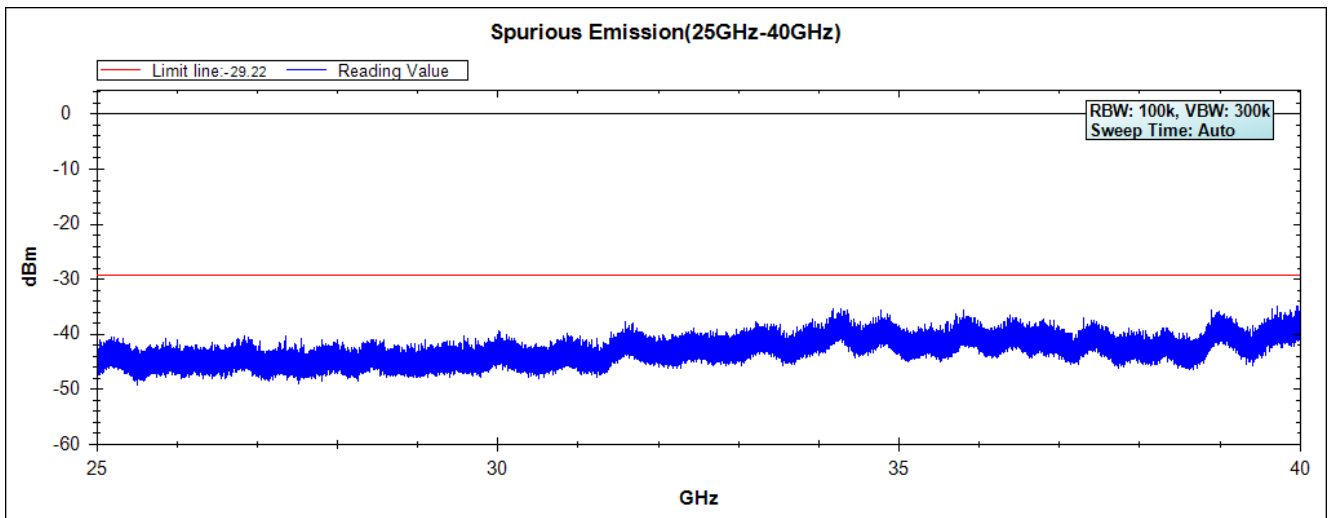
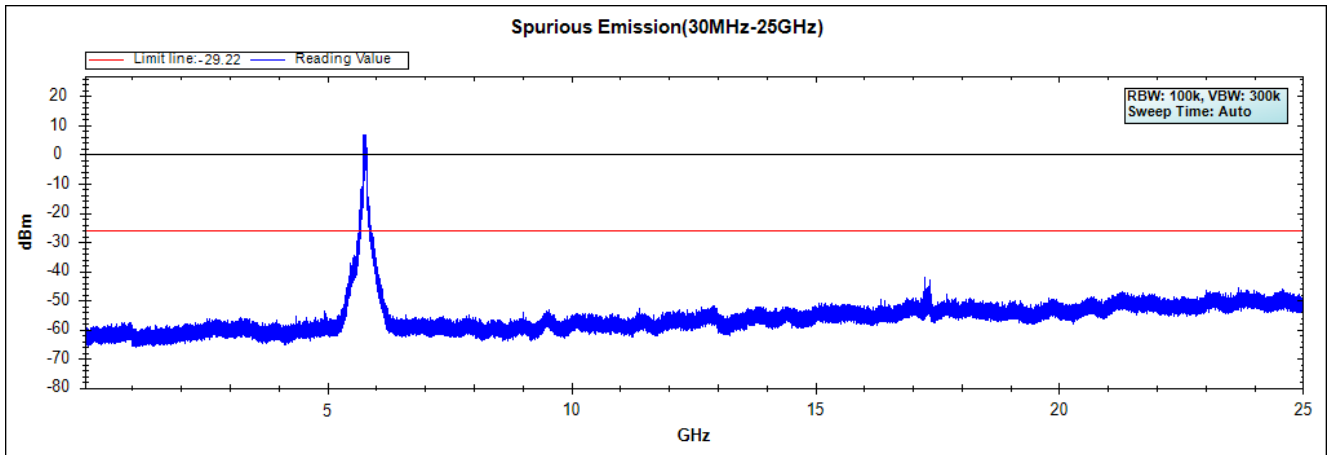

Note: The above test pattern is synthesized by multiple of the frequency range

**6. Band Edge**

**6.1. Test Equipment**

**RF Conducted Measurement**

The following test equipments are used during the band edge tests:

	Equipment	Manufacturer	Model No./Serial No.	Last Cal.
	Spectrum Analyzer	R&S	FSP40 / 100170	Jun, 2014
	Spectrum Analyzer	Agilent	E4407B / US39440758	Jun, 2014
X	Spectrum Analyzer	Agilent	N9010A / MY48030495	Apr., 2015
	8-WAY Power Divider	JFW	50PD-647 / 526770 0916	Apr., 2015

Note:

1. All equipments are calibrated with traceable calibrations. Each calibration is traceable to the national or international standards.
2. The test instruments marked with “X” are used to measure the final test results.

**RF Radiated Measurement:**

The following test equipments are used during the band edge tests:

Test Site		Equipment	Manufacturer	Model No./Serial No.	Last Cal.
☒ CB # 8	X	Spectrum Analyzer	R&S	FSP40/ 100339	Oct, 2014
	X	Horn Antenna	ETS-Lindgren	3117/ 35205	Mar., 2015
	X	Horn Antenna	Schwarzbeck	BBHA9170/209	Jan, 2015
	X	Horn Antenna	TRC	AH-0801/95051	Aug, 2014
	X	Pre-Amplifier	EMCI	EMC012630SE/980210	Jan, 2015
	X	Pre-Amplifier	MITEQ	JS41-001040000-58-5P/153945	Jul, 2014
	X	Pre-Amplifier	NARDA	DBL-1840N506/013	Jul, 2014

- Note:
1. All instruments are calibrated every one year.
  2. The test instruments marked by “X” are used to measure the final test results.

## 6.2. Test Setup

### RF Conducted Measurement

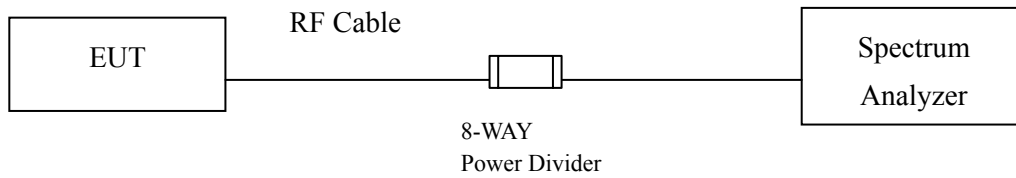

### RF Radiated Measurement:

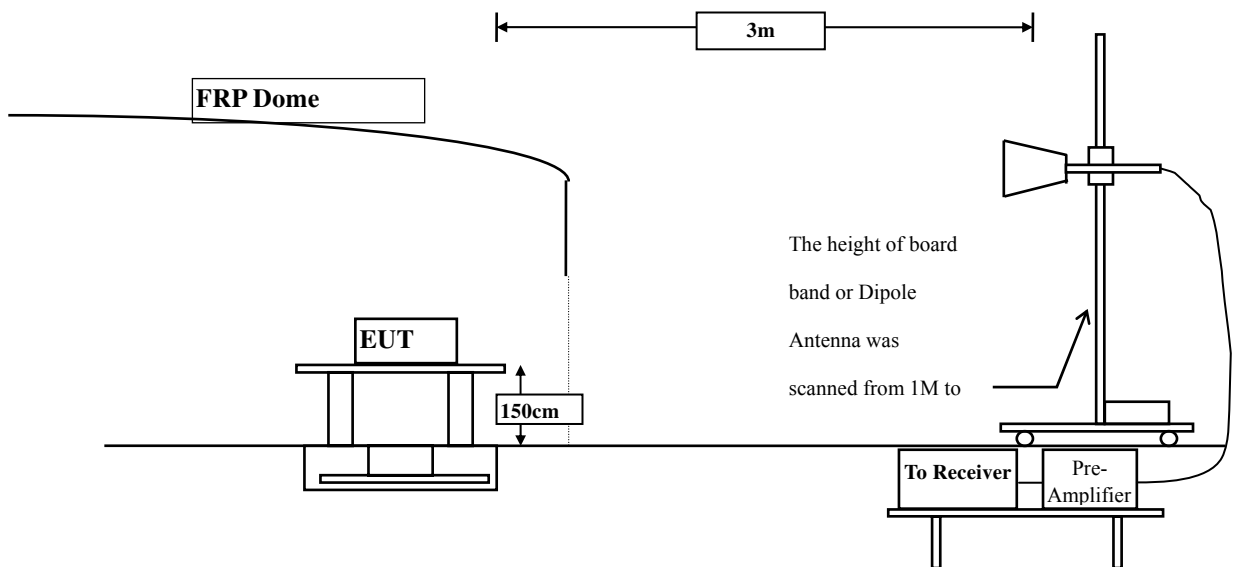

## 6.3. Limits

Emissions radiated outside of the specified frequency bands, except for harmonics, shall be attenuated by at least 20dB below the level of the fundamental or to the general radiated emission limits in paragraph 15.209, whichever is the lesser attenuation.

#### **6.4. Test Procedure**

The EUT was setup according to ANSI C63.10, 2009 and tested according to DTS test procedure of KDB558074 for compliance to FCC 47CFR 15.247 requirements.

The EUT is placed on a turn table which is 1.5 meter above ground. The turn table is rotated 360 degrees to determine the position of the maximum emission level. The EUT was positioned such that the distance from antenna to the EUT was 3 meters.

The antenna is scanned from 1 meter to 4 meters to find out the maximum emission level. This is repeated for both horizontal and vertical polarization of the antenna. In order to find the maximum emission, all of the interface cables were manipulated according to ANSI C63.10:2009 on radiated measurement.

#### **6.5. Uncertainty**

± 3.9 dB above 1GHz

± 3.8 dB below 1GHz



### 6.6. Test Result of Band Edge

Product : Intel® Dual Band Wireless-AC 8260  
 Test Item : Band Edge  
 Test Site : No.3 OATS  
 Test Mode : Mode 1 SISO A: Transmit (802.11b 1Mbps)

#### RF Radiated Measurement (Horizontal):

Channel No.	Frequency (MHz)	Correct Factor (dB)	Reading Level (dBuV)	Emission Level (dBuV/m)	Peak Limit (dBuV/m)	Average Limit (dBuV/m)	Result
01 (Peak)	2390.000	33.739	33.742	67.481	74.00	54.00	Pass
01 (Peak)	2400.000	33.752	46.901	80.652	--	--	Pass
01 (Peak)	2413.800	33.776	76.752	110.528	--	--	Pass
01 (Average)	2387.400	33.737	19.243	52.980	74.00	54.00	Pass
01 (Average)	2390.000	33.739	19.561	53.300	74.00	54.00	Pass
01 (Average)	2400.000	33.752	39.001	72.752	--	--	Pass
01 (Average)	2411.400	33.771	72.969	106.739	--	--	Pass

Figure Channel 01:

Horizontal (Peak)

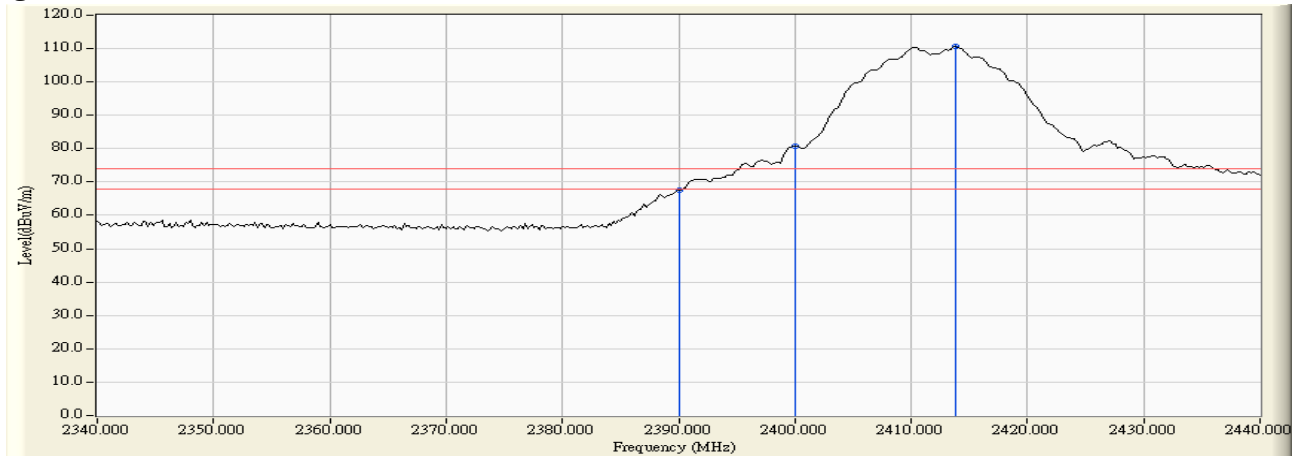
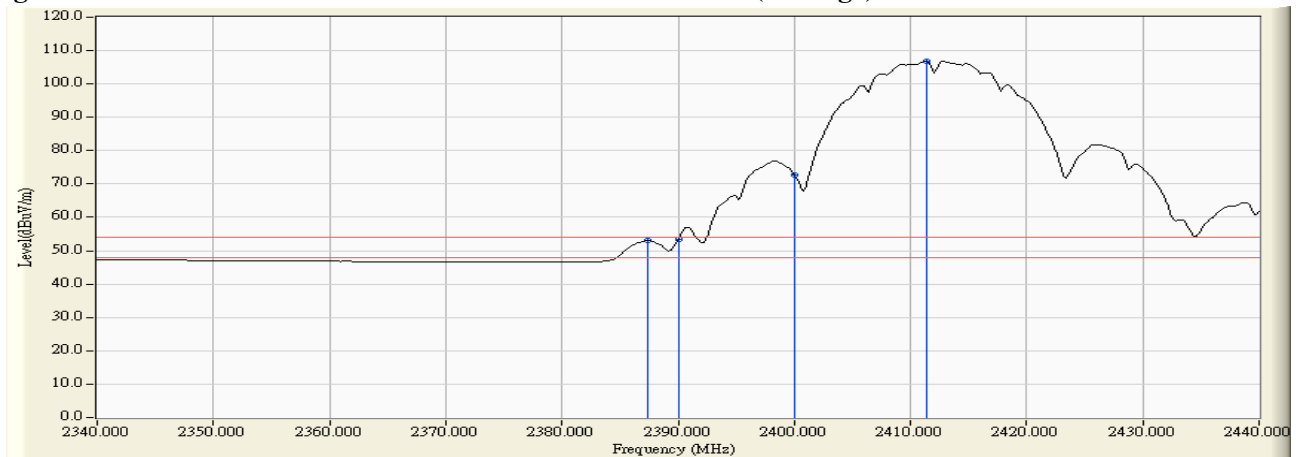

Figure Channel 01:

Horizontal (Average)



Note:

1. All readings above 1GHz are performed with peak and/or average measurements as necessary.
2. Peak measurements: RBW = 1MHz, VBW = 3 MHz, Sweep: Auto.
3. Average measurements: RBW = 1MHz, VBW = 10 Hz, Sweep: Auto.
4. “ \* ”, means this data is the worst emission level.
5. Measurement Level = Reading Level + Correct Factor.
6. The average measurement was not performed when the peak measured data under the limit of average detection.

Product : Intel® Dual Band Wireless-AC 8260  
 Test Item : Band Edge  
 Test Site : No.3 OATS  
 Test Mode : Mode 1 SISO A: Transmit (802.11b 1Mbps)

**RF Radiated Measurement (Vertical):**

Channel No.	Frequency (MHz)	Correct Factor (dB)	Reading Level (dBuV)	Emission Level (dBuV/m)	Peak Limit (dBuV/m)	Average Limit (dBuV/m)	Result
01 (Peak)	2390.000	32.267	32.284	64.551	74.00	54.00	Pass
01 (Peak)	2400.000	32.241	46.042	78.283	--	--	Pass
01 (Peak)	2413.800	32.257	75.785	108.042	--	--	Pass
01 (Average)	2390.000	32.267	18.854	51.121	74.00	54.00	Pass
01 (Average)	2400.000	32.241	37.470	69.711	74.00	54.00	Pass
01 (Average)	2411.400	32.247	70.684	102.930	--	--	Pass

**Figure Channel 01:**

**Vertical (Peak)**

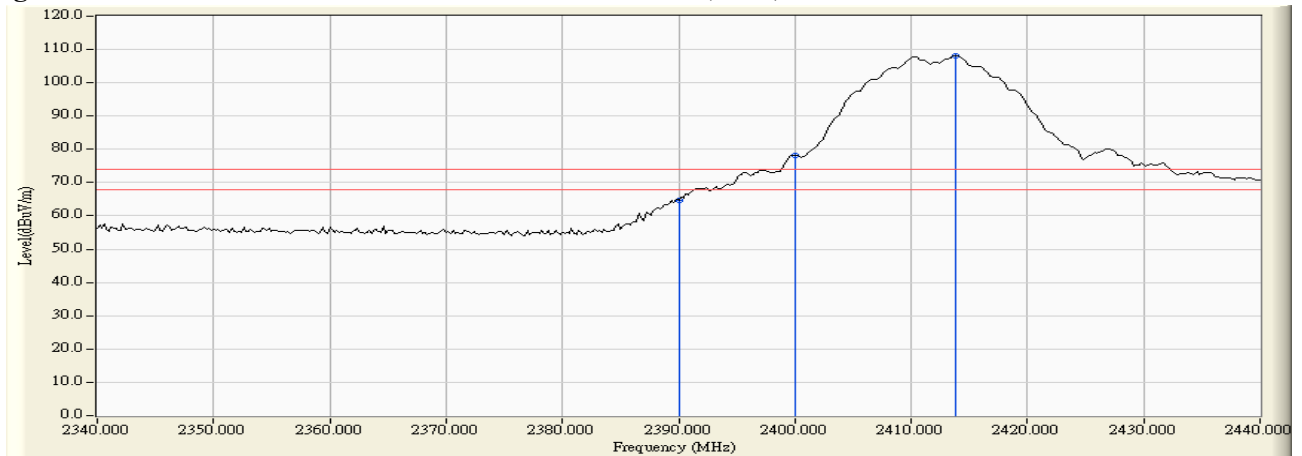

**Figure Channel 01:**

**Vertical (Average)**

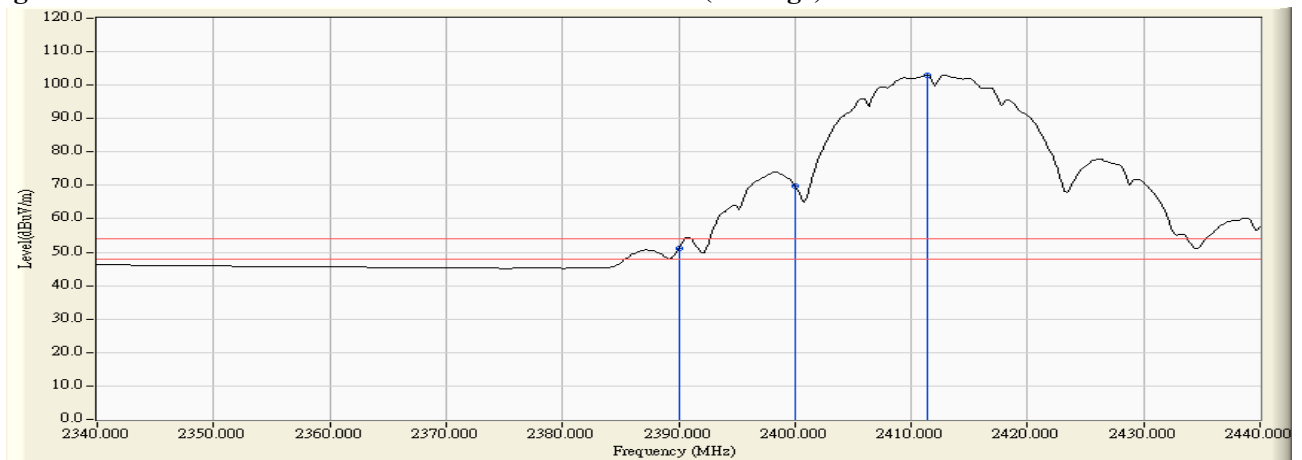

Note:

1. All readings above 1GHz are performed with peak and/or average measurements as necessary.
2. Peak measurements: RBW = 1MHz, VBW = 3 MHz, Sweep: Auto.
3. Average measurements: RBW = 1MHz, VBW = 10 Hz, Sweep: Auto.
4. “ \* ”, means this data is the worst emission level.
5. Measurement Level = Reading Level + Correct Factor.
6. The average measurement was not performed when the peak measured data under the limit of average detection.

Product : Intel® Dual Band Wireless-AC 8260  
 Test Item : Band Edge  
 Test Site : No.3 OATS  
 Test Mode : Mode 1 SISO A: Transmit (802.11b 1Mbps)

**RF Radiated Measurement (Horizontal):**

Channel No.	Frequency (MHz)	Correct Factor (dB)	Reading Level (dBuV)	Emission Level (dBuV/m)	Peak Limit (dBuV/m)	Average Limit (dBuV/m)	Result
11 (Peak)	2463.700	33.897	77.574	111.471	--	--	Pass
11 (Peak)	2483.500	33.951	38.680	72.630	74.00	54.00	Pass
11 (Average)	2462.700	33.895	72.181	106.075	--	--	Pass
11 (Average)	2483.500	33.951	18.472	52.422	74.00	54.00	Pass

**Figure Channel 11: Horizontal (Peak)**

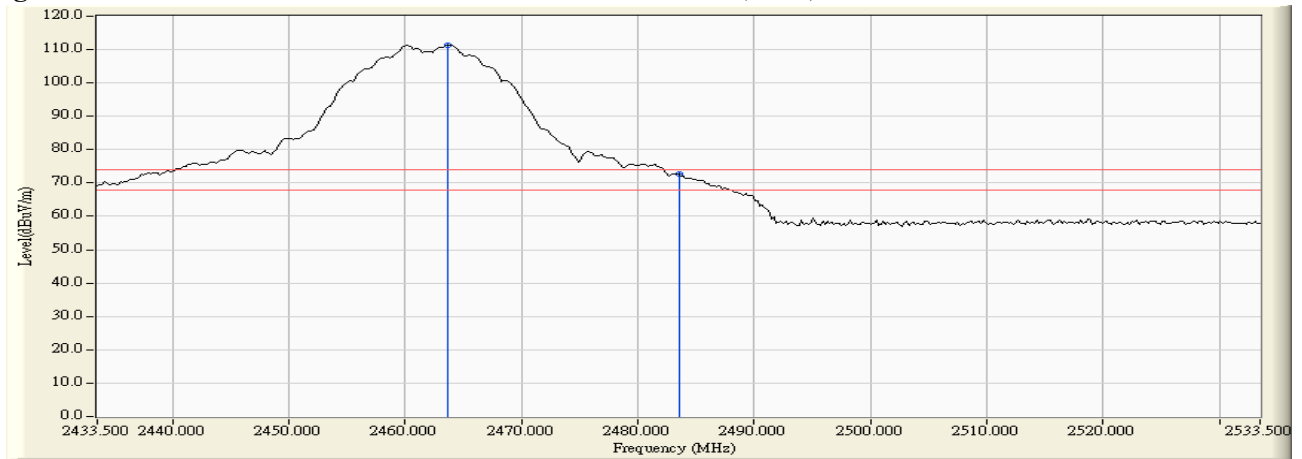

**Figure Channel 1: Horizontal (Average)**

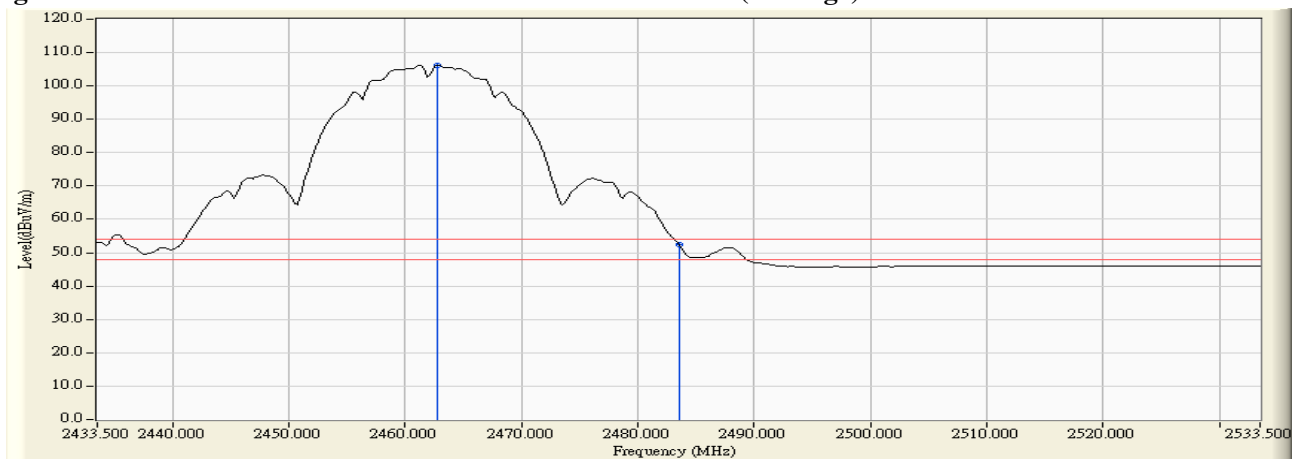

Note:

1. All readings above 1GHz are performed with peak and/or average measurements as necessary.
2. Peak measurements: RBW = 1MHz, VBW = 3 MHz, Sweep: Auto.
3. Average measurements: RBW = 1MHz, VBW = 10 Hz, Sweep: Auto.
4. “ \* ”, means this data is the worst emission level.
5. Measurement Level = Reading Level + Correct Factor.
6. The average measurement was not performed when the peak measured data under the limit of average detection.

Product : Intel® Dual Band Wireless-AC 8260  
 Test Item : Band Edge  
 Test Site : No.3 OATS  
 Test Mode : Mode 1 SISO A: Transmit (802.11b 1Mbps)

**RF Radiated Measurement (Vertical):**

Channel No.	Frequency (MHz)	Correct Factor (dB)	Reading Level (dBuV)	Emission Level (dBuV/m)	Peak Limit (dBuV/m)	Average Limit (dBuV/m)	Result
11 (Peak)	2463.700	32.489	77.548	110.037	--	--	Pass
11 (Peak)	2483.500	32.586	39.166	71.751	74.00	54.00	Pass
11 (Average)	2462.700	32.484	72.081	104.565	--	--	Pass
11 (Average)	2483.500	32.586	19.390	51.975	74.00	54.00	Pass

**Figure Channel 11: Vertical (Peak)**

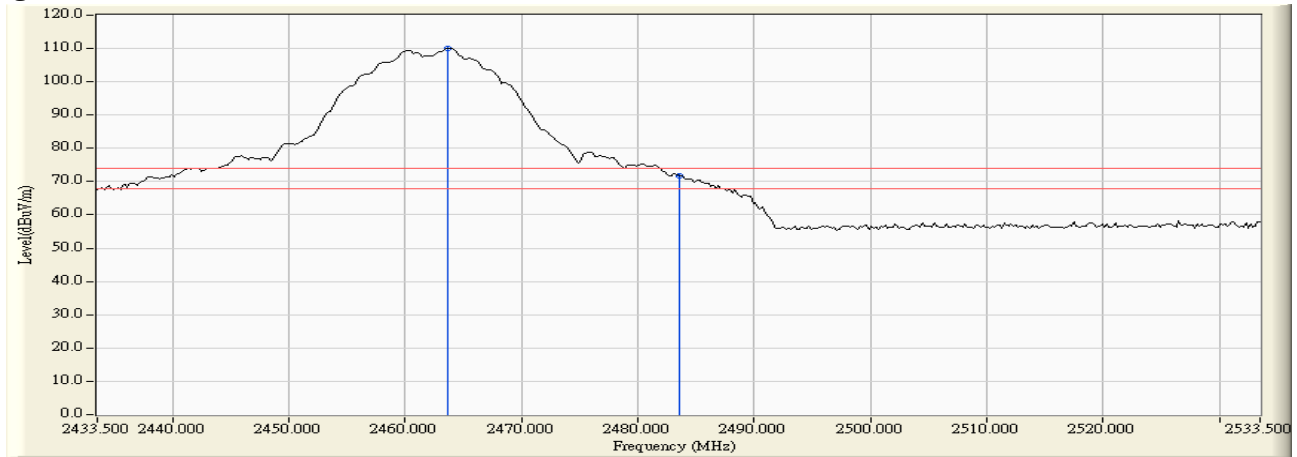

**Figure Channel 11: Vertical (Average)**

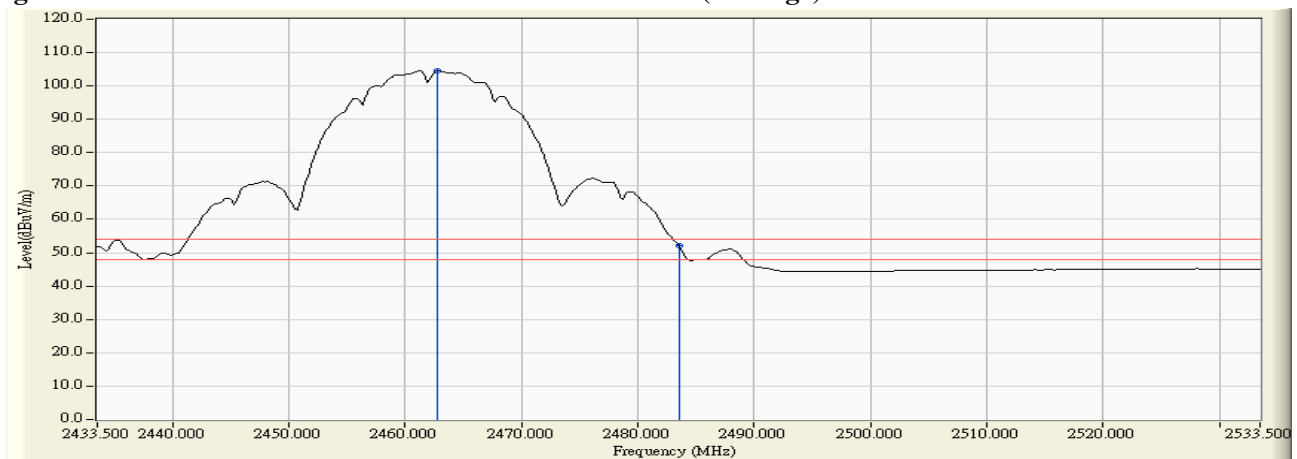

Note:

1. All readings above 1GHz are performed with peak and/or average measurements as necessary.
2. Peak measurements: RBW = 1MHz, VBW = 3 MHz, Sweep: Auto.
3. Average measurements: RBW = 1MHz, VBW = 10 Hz, Sweep: Auto.
4. “ \* ”, means this data is the worst emission level.
5. Measurement Level = Reading Level + Correct Factor.
6. The average measurement was not performed when the peak measured data under the limit of average detection.



Product : Intel® Dual Band Wireless-AC 8260  
 Test Item : Band Edge  
 Test Site : No.3 OATS  
 Test Mode : Mode 1 SISO A: Transmit (802.11b 1Mbps)

**RF Radiated Measurement (Horizontal):**

Channel No.	Frequency (MHz)	Correct Factor (dB)	Reading Level (dBuV)	Emission Level (dBuV/m)	Peak Limit (dBuV/m)	Average Limit (dBuV/m)	Result
12 (Peak)	2465.300	33.901	74.138	108.039	--	--	Pass
12 (Peak)	2483.500	33.951	38.905	72.855	74.00	54.00	Pass
12 (Average)	2466.300	33.904	68.506	102.410	--	--	Pass
12 (Average)	2483.500	33.951	17.517	51.467	74.00	54.00	Pass

**Figure Channel 12: Horizontal (Peak)**

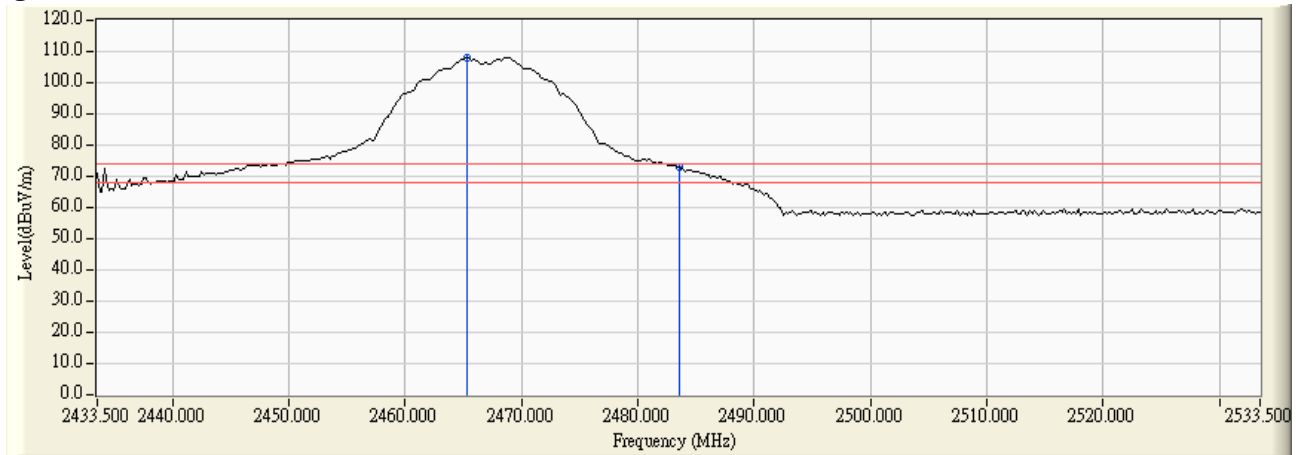

**Figure Channel 2: Horizontal (Average)**

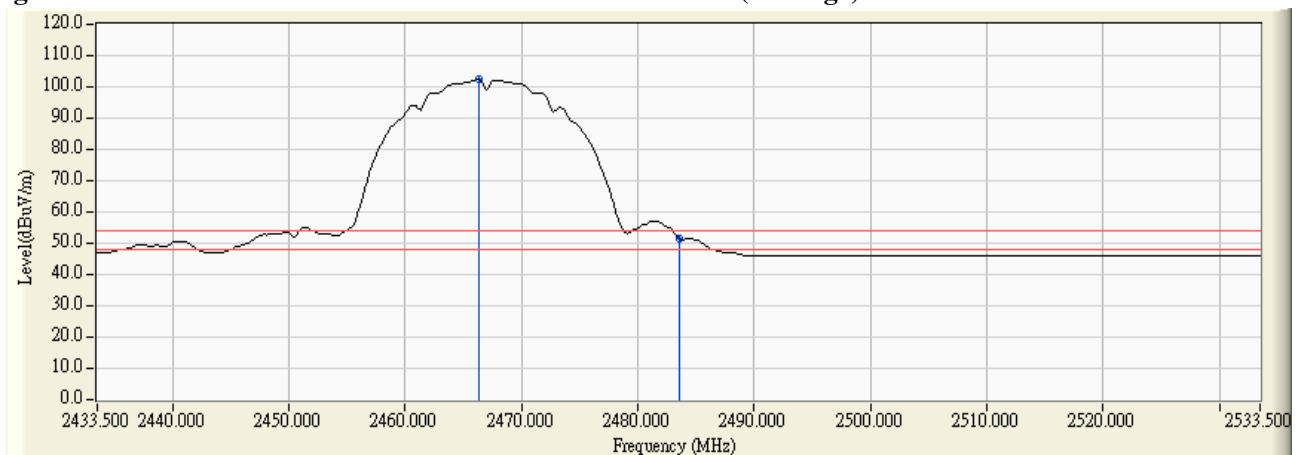

Note:

1. All readings above 1GHz are performed with peak and/or average measurements as necessary.
2. Peak measurements: RBW = 1MHz, VBW = 3 MHz, Sweep: Auto.
3. Average measurements: RBW = 1MHz, VBW = 10 Hz, Sweep: Auto.
4. “ \* ”, means this data is the worst emission level.
5. Measurement Level = Reading Level + Correct Factor.
6. The average measurement was not performed when the peak measured data under the limit of average detection.

Product : Intel® Dual Band Wireless-AC 8260  
 Test Item : Band Edge  
 Test Site : No.3 OATS  
 Test Mode : Mode 1 SISO A: Transmit (802.11b 1Mbps)

**RF Radiated Measurement (Vertical):**

Channel No.	Frequency (MHz)	Correct Factor (dB)	Reading Level (dBuV)	Emission Level (dBuV/m)	Peak Limit (dBuV/m)	Average Limit (dBuV/m)	Result
12 (Peak)	2468.700	32.513	71.574	104.087	--	--	Pass
12 (Peak)	2483.500	32.586	35.589	68.174	74.00	54.00	Pass
12 (Average)	2466.300	32.501	66.443	98.944	--	--	Pass
12 (Average)	2483.500	32.586	15.746	48.331	74.00	54.00	Pass

**Figure Channel 12: Vertical (Peak)**

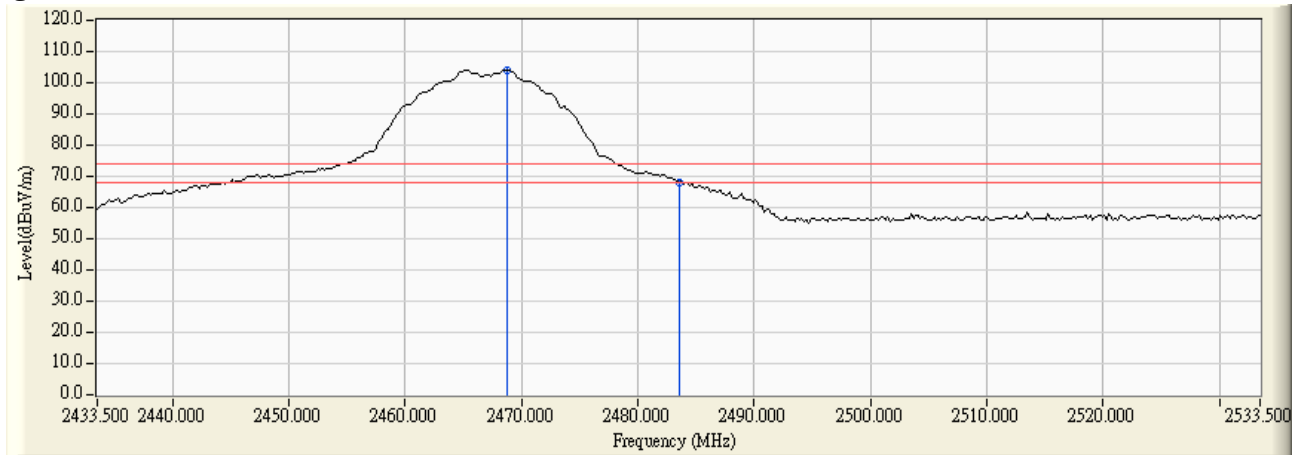

**Figure Channel 12: Vertical (Average)**

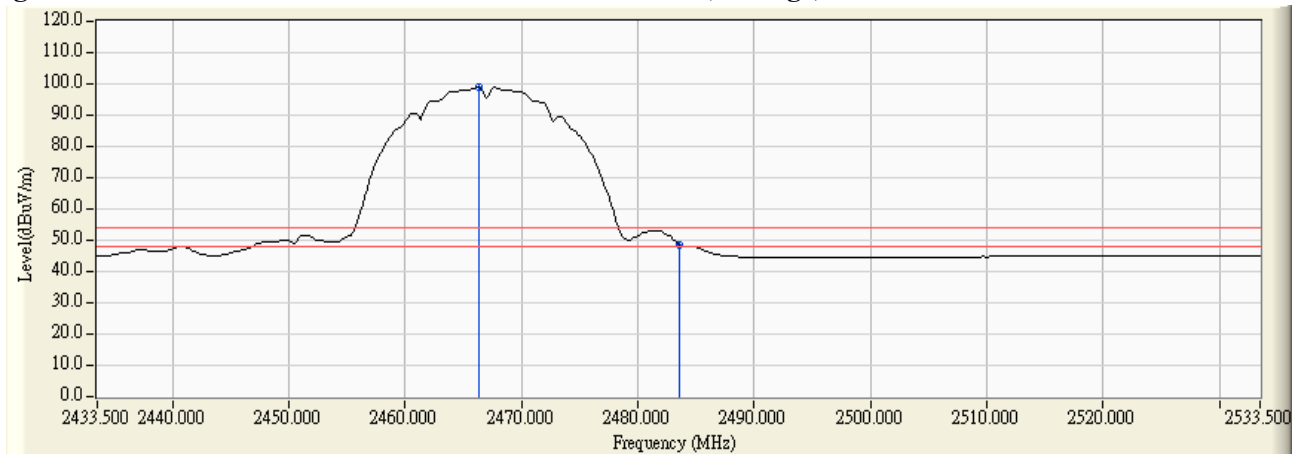

Note:

1. All readings above 1GHz are performed with peak and/or average measurements as necessary.
2. Peak measurements: RBW = 1MHz, VBW = 3 MHz, Sweep: Auto.
3. Average measurements: RBW = 1MHz, VBW = 10 Hz, Sweep: Auto.
4. “ \* ”, means this data is the worst emission level.
5. Measurement Level = Reading Level + Correct Factor.
6. The average measurement was not performed when the peak measured data under the limit of average detection.

Product : Intel® Dual Band Wireless-AC 8260  
 Test Item : Band Edge  
 Test Site : No.3 OATS  
 Test Mode : Mode 1 SISO A: Transmit (802.11g 6Mbps)

**RF Radiated Measurement (Horizontal):**

Channel No.	Frequency (MHz)	Correct Factor (dB)	Reading Level (dBuV)	Emission Level (dBuV/m)	Peak Limit (dBuV/m)	Average Limit (dBuV/m)	Result
01 (Peak)	2390.000	33.739	39.656	73.395	74.00	54.00	Pass
01 (Peak)	2400.000	33.752	56.160	89.911	--	--	Pass
01 (Peak)	2414.600	33.778	77.914	111.692	--	--	Pass
01 (Average)	2390.000	33.739	19.456	53.195	74.00	54.00	Pass
01 (Average)	2400.000	33.752	40.220	73.971	--	--	Pass
01 (Average)	2414.800	33.778	66.907	100.686	--	--	Pass

**Figure Channel 01: Horizontal (Peak)**

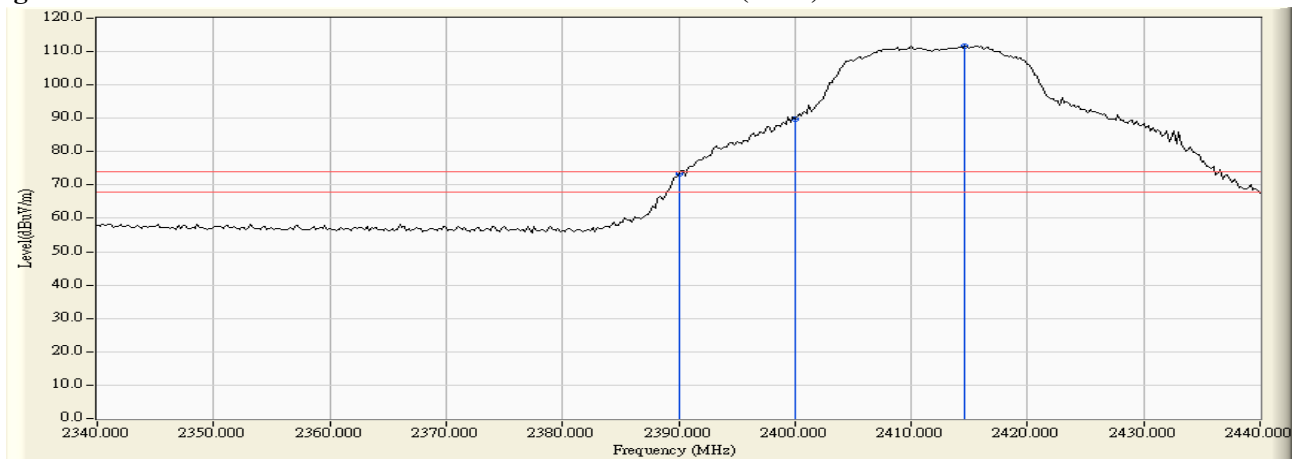

**Figure Channel 01: Horizontal (Average)**

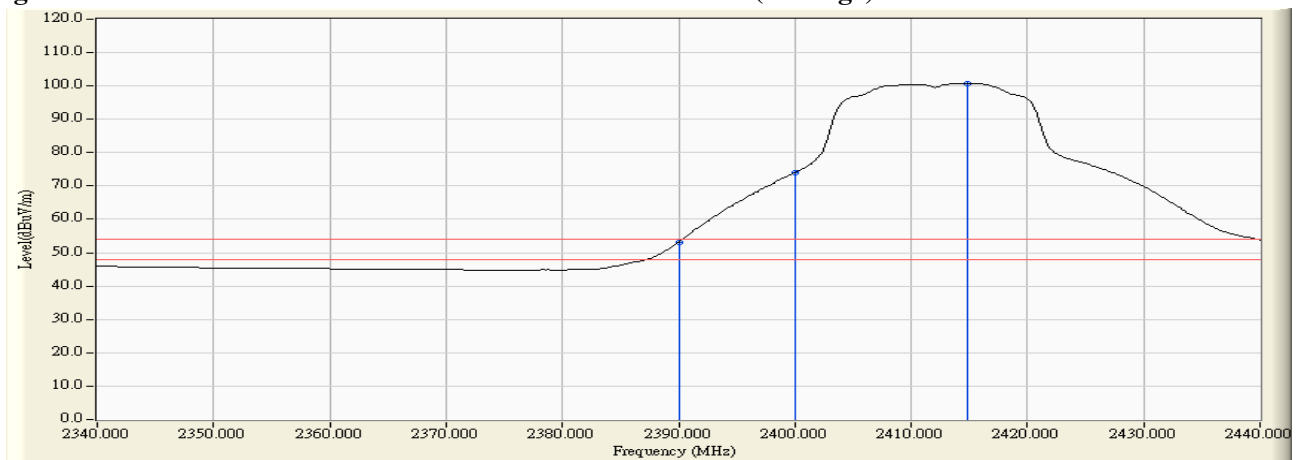

Note:

1. All readings above 1GHz are performed with peak and/or average measurements as necessary.
2. Peak measurements: RBW = 1MHz, VBW = 3 MHz, Sweep: Auto.
3. Average measurements: RBW = 1MHz, VBW = 10 Hz, Sweep: Auto.
4. “ \* ”, means this data is the worst emission level.
5. Measurement Level = Reading Level + Correct Factor.
6. The average measurement was not performed when the peak measured data under the limit of average detection.

Product : Intel® Dual Band Wireless-AC 8260  
 Test Item : Band Edge  
 Test Site : No.3 OATS  
 Test Mode : Mode 1 SISO A: Transmit (802.11g 6Mbps)

**RF Radiated Measurement (Vertical):**

Channel No.	Frequency (MHz)	Correct Factor (dB)	Reading Level (dBuV)	Emission Level (dBuV/m)	Peak Limit (dBuV/m)	Average Limit (dBuV/m)	Result
01 (Peak)	2390.000	32.267	36.118	68.385	74.00	54.00	Pass
01 (Peak)	2400.000	32.241	53.943	86.184	--	--	Pass
01 (Peak)	2410.200	32.244	76.121	108.365	--	--	Pass
01 (Average)	2390.000	32.267	18.072	50.339	74.00	54.00	Pass
01 (Average)	2400.000	32.241	38.585	70.826	--	--	Pass
01 (Average)	2414.400	32.260	65.274	97.534	--	--	Pass

**Figure Channel 01:**

**Vertical (Peak)**

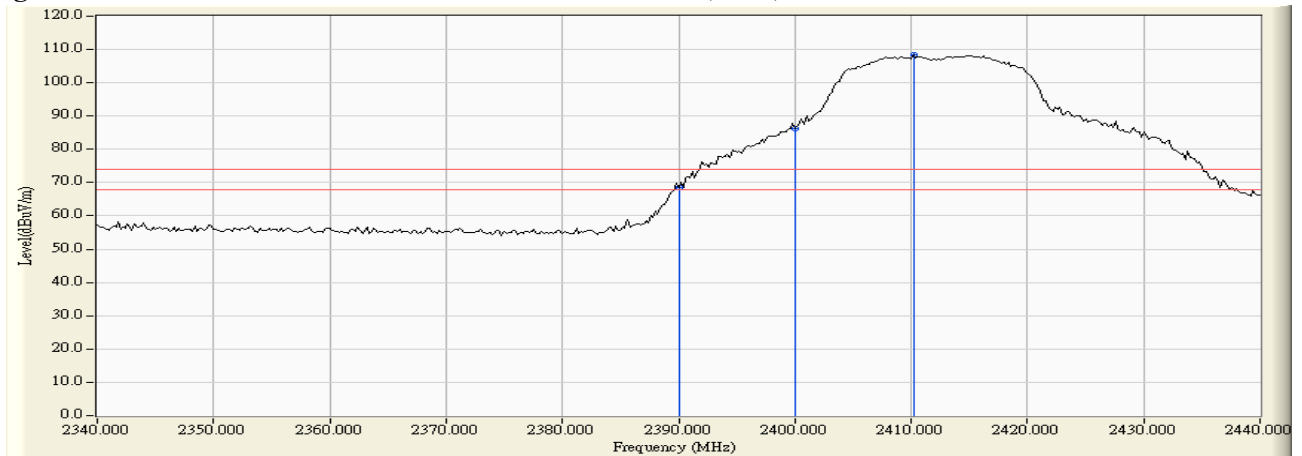

**Figure Channel 01:**

**Vertical (Average)**

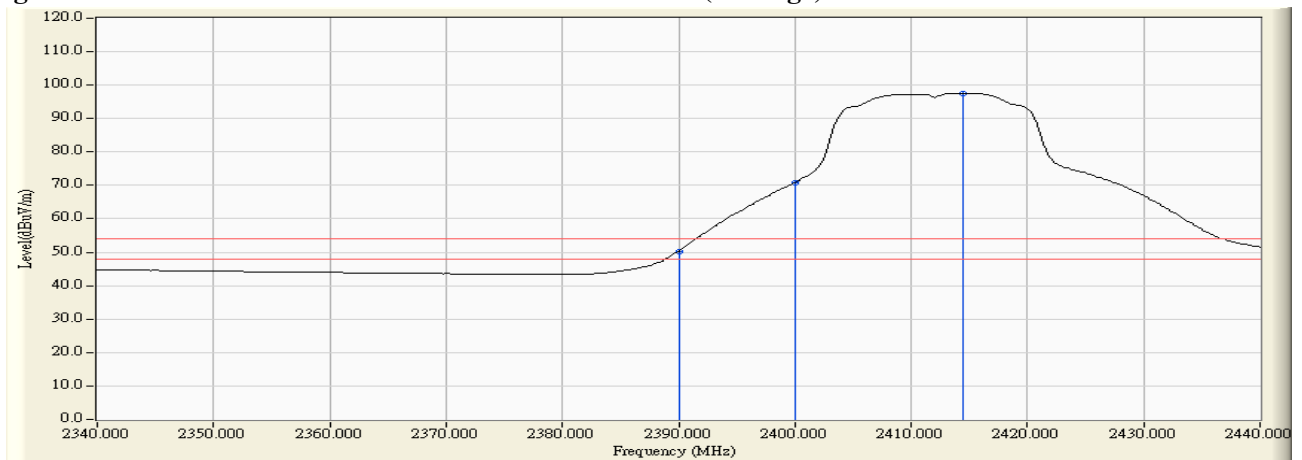

Note:

1. All readings above 1GHz are performed with peak and/or average measurements as necessary.
2. Peak measurements: RBW = 1MHz, VBW = 3 MHz, Sweep: Auto.
3. Average measurements: RBW = 1MHz, VBW = 10 Hz, Sweep: Auto.
4. “ \* ”, means this data is the worst emission level.
5. Measurement Level = Reading Level + Correct Factor.
6. The average measurement was not performed when the peak measured data under the limit of average detection.



Product : Intel® Dual Band Wireless-AC 8260  
 Test Item : Band Edge  
 Test Site : No.3 OATS  
 Test Mode : Mode 1 SISO A: Transmit (802.11g 6Mbps)

**RF Radiated Measurement (Horizontal):**

Channel No.	Frequency (MHz)	Correct Factor (dB)	Reading Level (dBuV)	Emission Level (dBuV/m)	Peak Limit (dBuV/m)	Average Limit (dBuV/m)	Result
10 (Peak)	2460.700	33.890	78.909	112.798	--	--	Pass
10 (Peak)	2483.500	33.951	35.248	69.198	74.00	54.00	Pass
10 (Peak)	2485.300	33.954	36.141	70.096	74.00	54.00	Pass
10 (Average)	2460.500	33.889	67.956	101.845	--	--	Pass
10 (Average)	2483.500	33.951	19.164	53.114	74.00	54.00	Pass

**Figure Channel 10: Horizontal (Peak)**

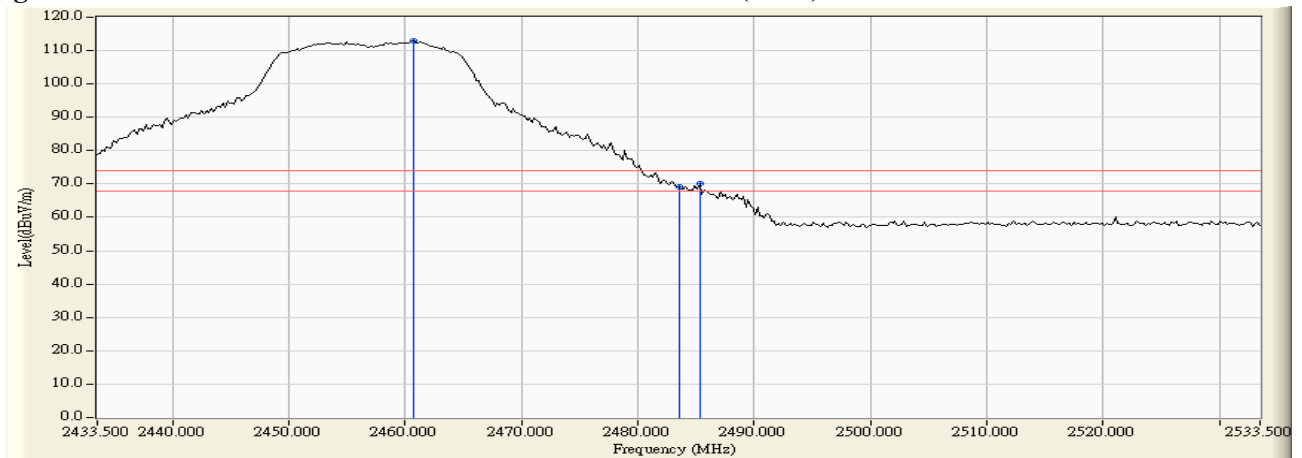

**Figure Channel 10: Horizontal (Average)**

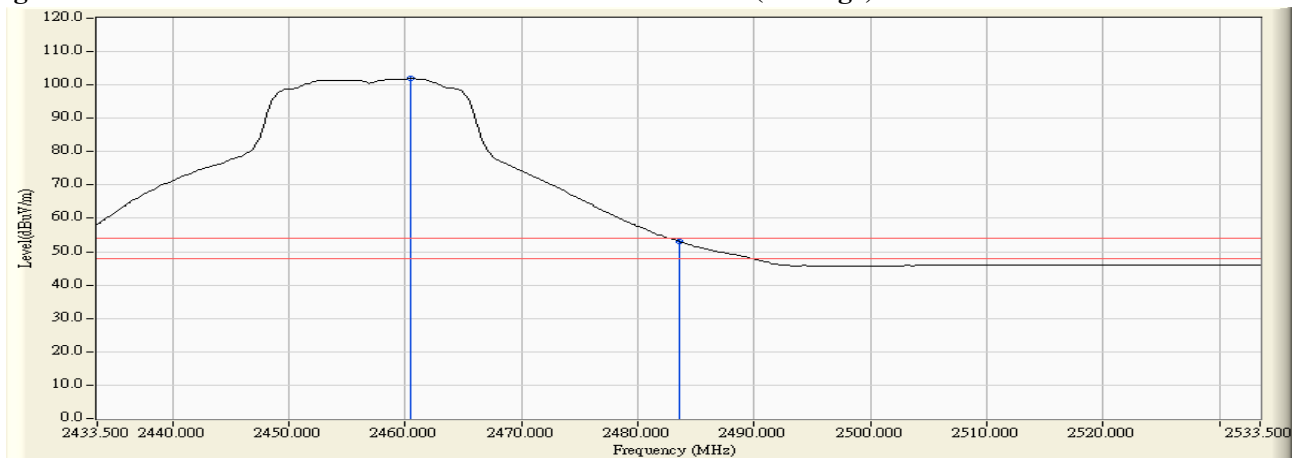

Note:

1. All readings above 1GHz are performed with peak and/or average measurements as necessary.
2. Peak measurements: RBW = 1MHz, VBW = 3 MHz, Sweep: Auto.
3. Average measurements: RBW = 1MHz, VBW = 10 Hz, Sweep: Auto.
4. “ \* ”, means this data is the worst emission level.
5. Measurement Level = Reading Level + Correct Factor.
6. The average measurement was not performed when the peak measured data under the limit of average detection.

Product : Intel® Dual Band Wireless-AC 8260  
 Test Item : Band Edge  
 Test Site : No.3 OATS  
 Test Mode : Mode 1 SISO A: Transmit (802.11g 6Mbps)

**RF Radiated Measurement (Vertical):**

Channel No.	Frequency (MHz)	Correct Factor (dB)	Reading Level (dBuV)	Emission Level (dBuV/m)	Peak Limit (dBuV/m)	Average Limit (dBuV/m)	Result
10 (Peak)	2460.700	32.475	78.424	110.898	--	--	Pass
10 (Peak)	2483.500	32.586	35.035	67.620	74.00	54.00	Pass
10 (Average)	2460.700	32.475	67.427	99.901	--	--	Pass
10 (Average)	2483.500	32.586	19.481	52.066	74.00	54.00	Pass

**Figure Channel 10: Vertical (Peak)**

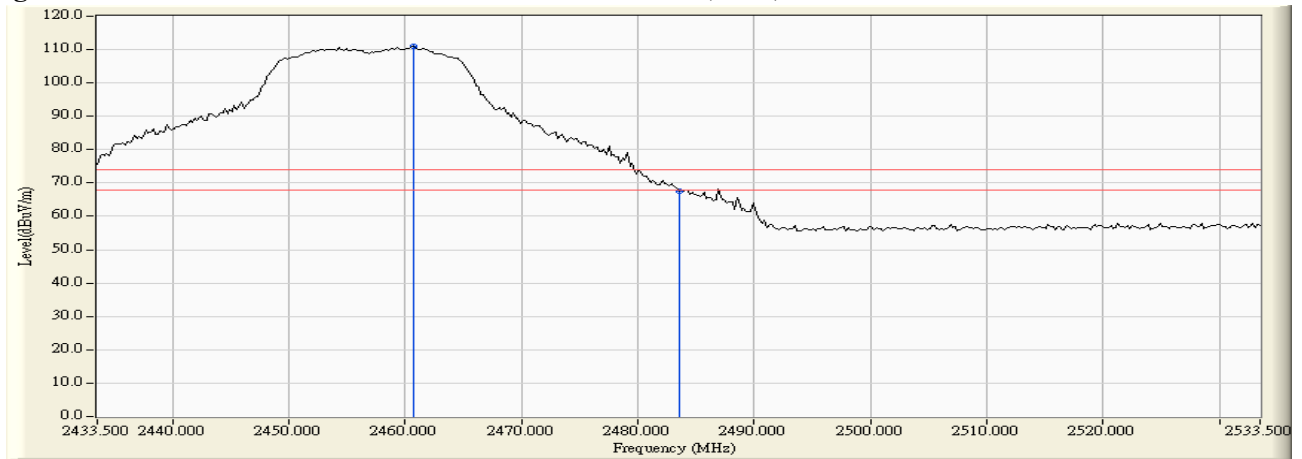

**Figure Channel 10: Vertical (Average)**

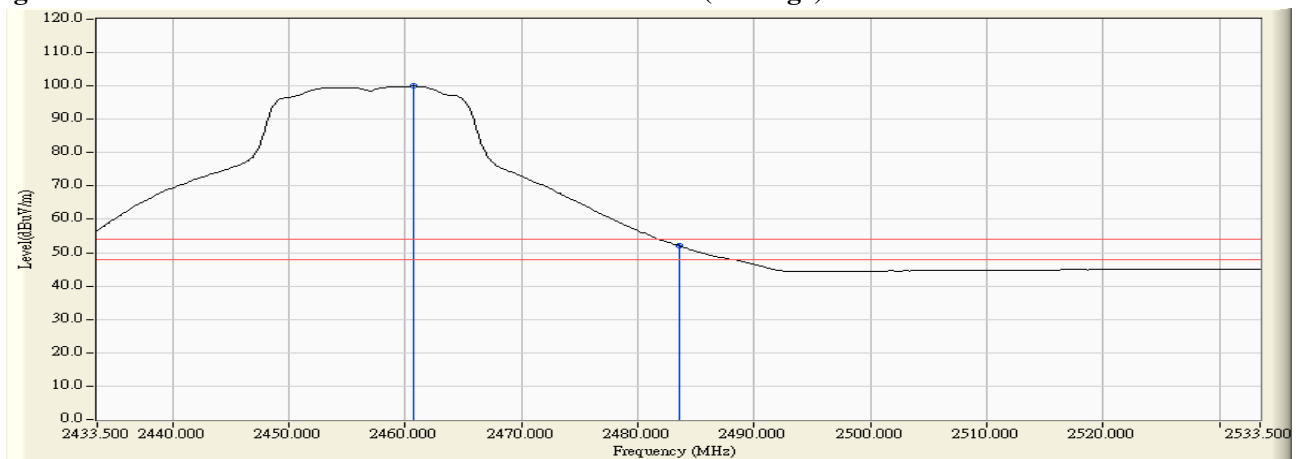

Note:

1. All readings above 1GHz are performed with peak and/or average measurements as necessary.
2. Peak measurements: RBW = 1MHz, VBW = 3 MHz, Sweep: Auto.
3. Average measurements: RBW = 1MHz, VBW = 10 Hz, Sweep: Auto.
4. “ \* ”, means this data is the worst emission level.
5. Measurement Level = Reading Level + Correct Factor.
6. The average measurement was not performed when the peak measured data under the limit of average detection.

Product : Intel® Dual Band Wireless-AC 8260  
 Test Item : Band Edge  
 Test Site : No.3 OATS  
 Test Mode : Mode 1 SISO A: Transmit (802.11g 6Mbps)

**RF Radiated Measurement (Horizontal):**

Channel No.	Frequency (MHz)	Correct Factor (dB)	Reading Level (dBuV)	Emission Level (dBuV/m)	Peak Limit (dBuV/m)	Average Limit (dBuV/m)	Result
11 (Peak)	2464.300	33.899	77.761	111.660	--	--	Pass
11 (Peak)	2483.500	33.951	36.895	70.845	74.00	54.00	Pass
11 (Average)	2463.700	33.897	66.551	100.448	--	--	Pass
11 (Average)	2483.500	33.951	19.385	53.335	74.00	54.00	Pass

**Figure Channel 11: Horizontal (Peak)**

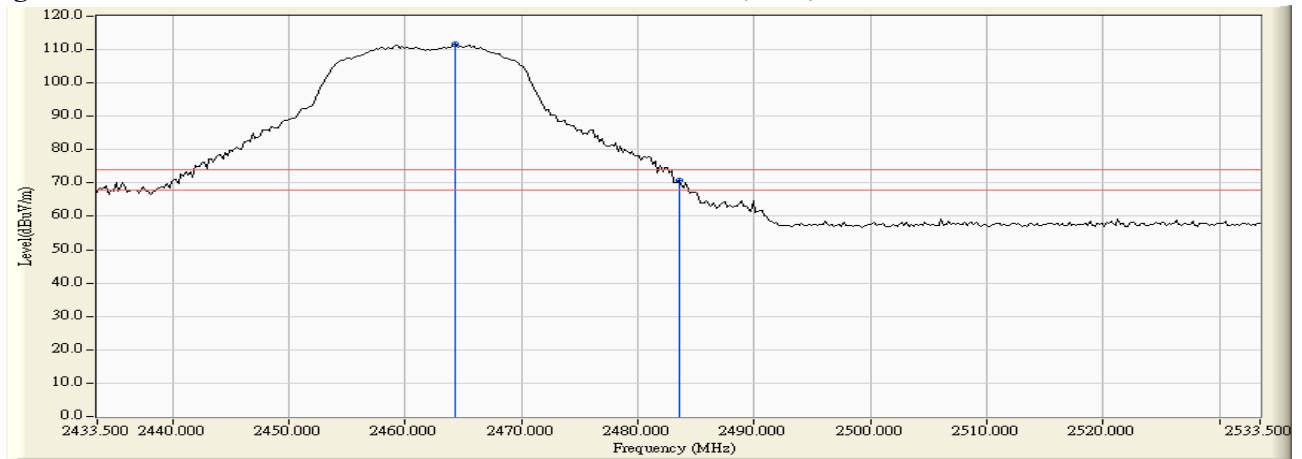

**Figure Channel 11: Horizontal (Average)**

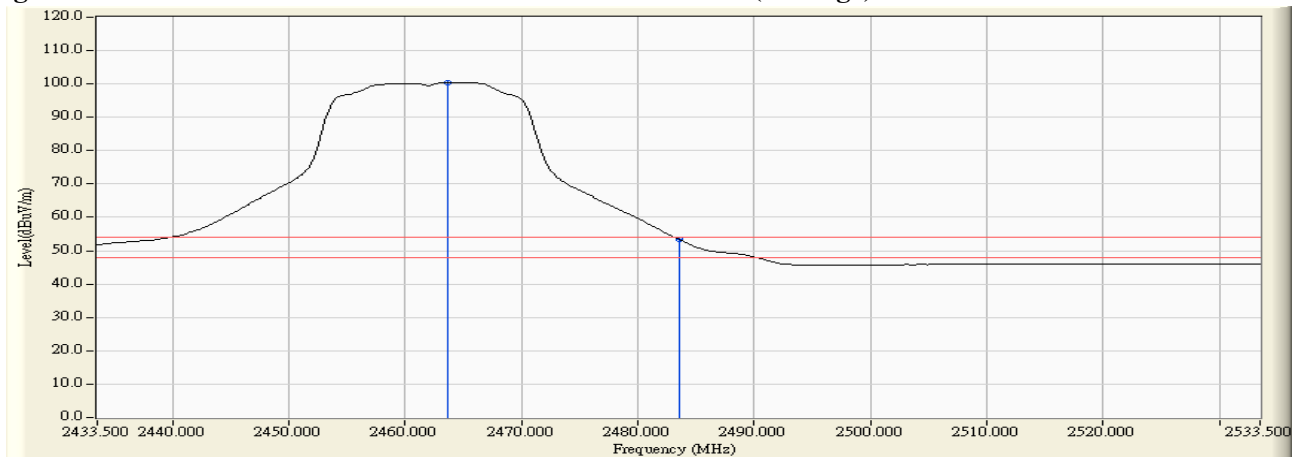

Note:

1. All readings above 1GHz are performed with peak and/or average measurements as necessary.
2. Peak measurements: RBW = 1MHz, VBW = 3 MHz, Sweep: Auto.
3. Average measurements: RBW = 1MHz, VBW = 10 Hz, Sweep: Auto.
4. “ \* ”, means this data is the worst emission level.
5. Measurement Level = Reading Level + Correct Factor.
6. The average measurement was not performed when the peak measured data under the limit of average detection.

Product : Intel® Dual Band Wireless-AC 8260  
 Test Item : Band Edge  
 Test Site : No.3 OATS  
 Test Mode : Mode 1 SISO A: Transmit (802.11g 6Mbps)

**RF Radiated Measurement (Vertical):**

Channel No.	Frequency (MHz)	Correct Factor (dB)	Reading Level (dBuV)	Emission Level (dBuV/m)	Peak Limit (dBuV/m)	Average Limit (dBuV/m)	Result
11 (Peak)	2465.500	32.497	77.402	109.899	--	--	Pass
11 (Peak)	2483.500	32.586	36.032	68.617	74.00	54.00	Pass
11 (Average)	2465.300	32.496	66.274	98.770	--	--	Pass
11 (Average)	2483.500	32.586	19.724	52.309	74.00	54.00	Pass

**Figure Channel 11: Vertical (Peak)**

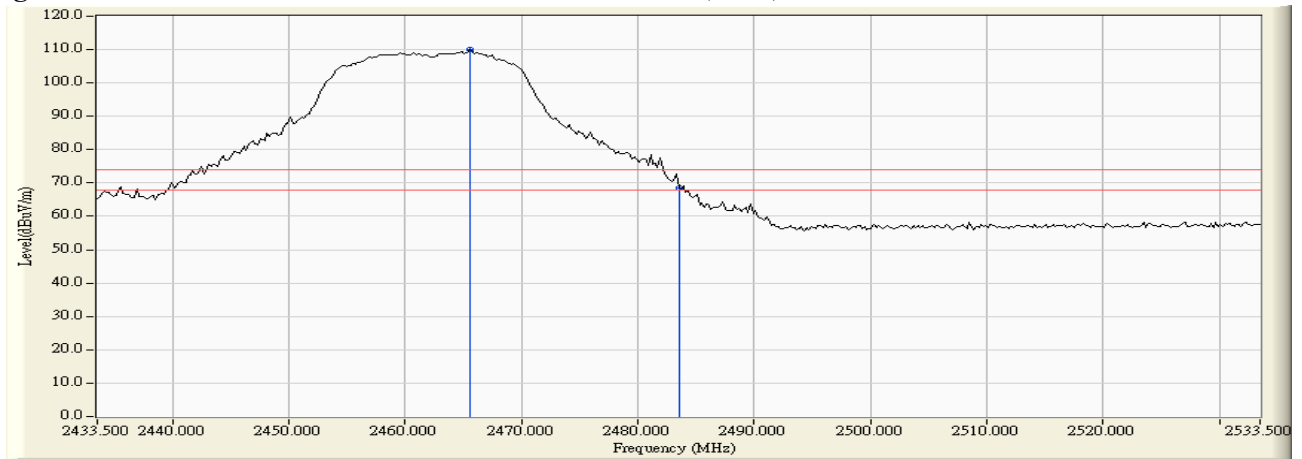

**Figure Channel 11: Vertical (Average)**

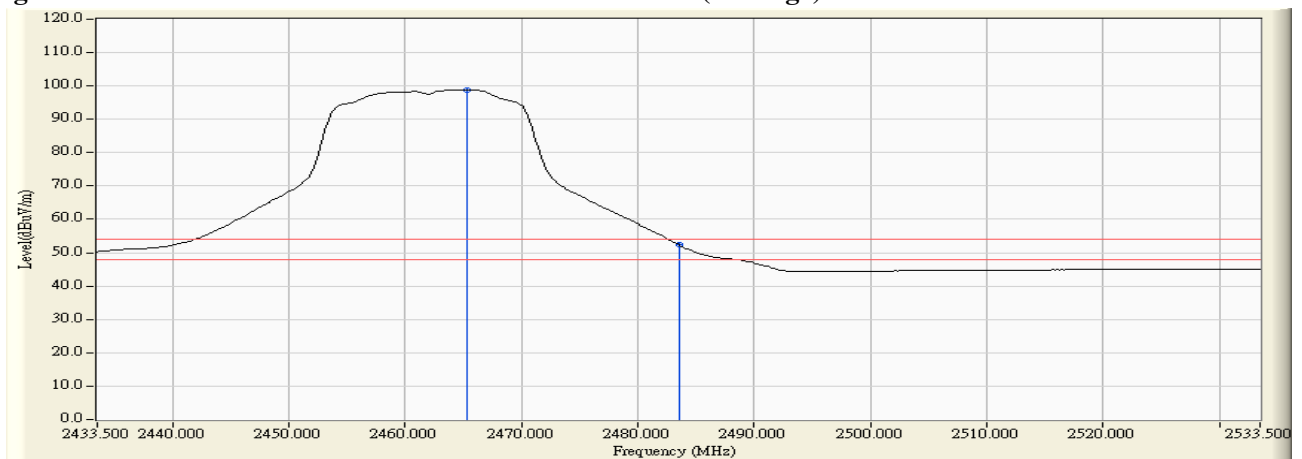

Note:

1. All readings above 1GHz are performed with peak and/or average measurements as necessary.
2. Peak measurements: RBW = 1MHz, VBW = 3 MHz, Sweep: Auto.
3. Average measurements: RBW = 1MHz, VBW = 10 Hz, Sweep: Auto.
4. “ \* ”, means this data is the worst emission level.
5. Measurement Level = Reading Level + Correct Factor.
6. The average measurement was not performed when the peak measured data under the limit of average detection.



Product : Intel® Dual Band Wireless-AC 8260  
 Test Item : Band Edge  
 Test Site : No.3 OATS  
 Test Mode : Mode 1 SISO A: Transmit (802.11g 6Mbps)

**RF Radiated Measurement (Horizontal):**

Channel No.	Frequency (MHz)	Correct Factor (dB)	Reading Level (dBuV)	Emission Level (dBuV/m)	Peak Limit (dBuV/m)	Average Limit (dBuV/m)	Result
12 (Peak)	2469.300	33.911	72.580	106.492	--	--	Pass
12 (Peak)	2483.500	33.951	37.378	71.328	74.00	54.00	Pass
12 (Average)	2468.900	33.911	62.041	95.952	--	--	Pass
12 (Average)	2483.500	33.951	19.301	53.251	74.00	54.00	Pass

**Figure Channel 12: Horizontal (Peak)**

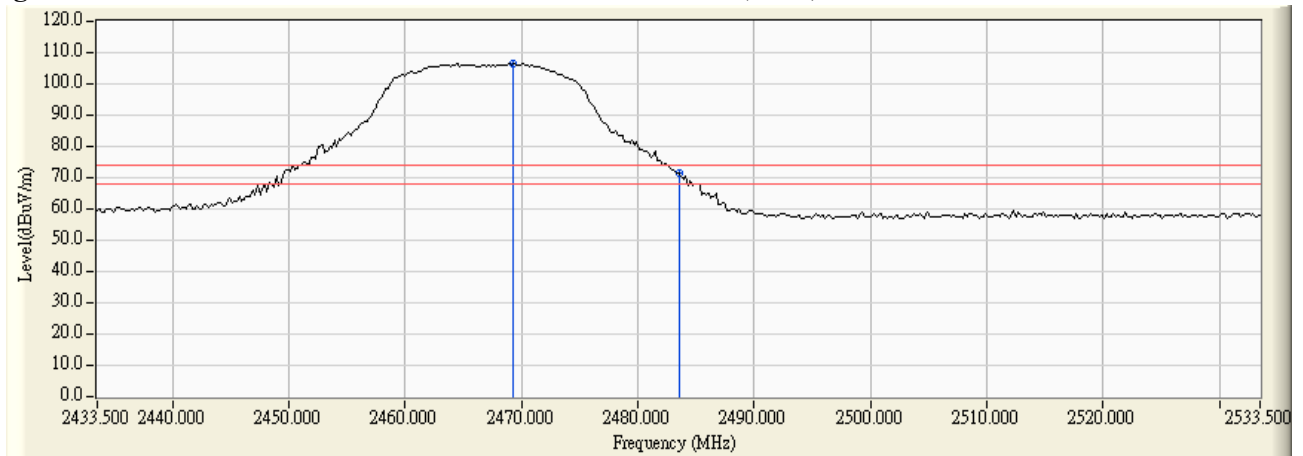

**Figure Channel 12: Horizontal (Average)**

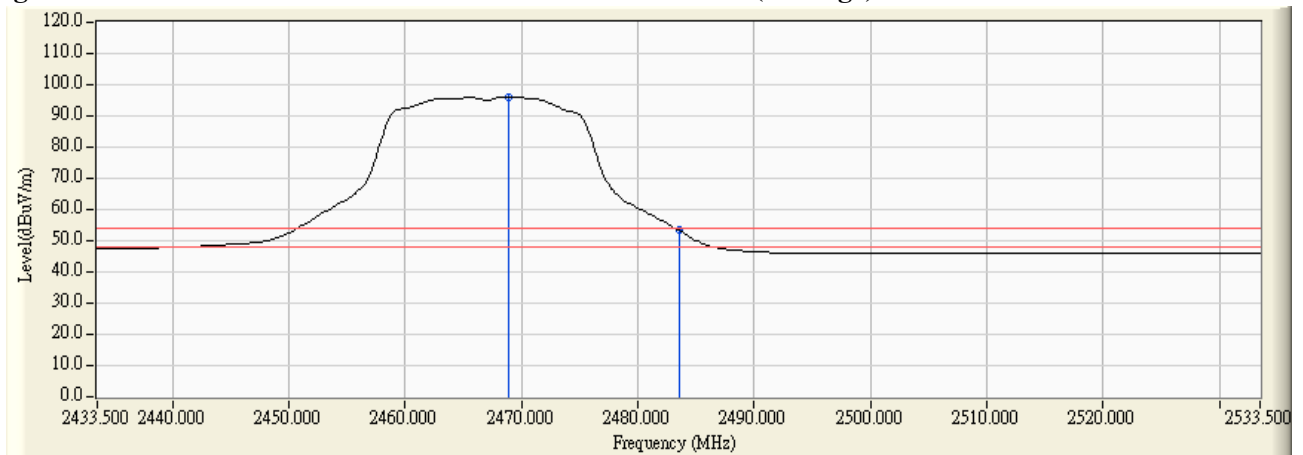

Note:

1. All readings above 1GHz are performed with peak and/or average measurements as necessary.
2. Peak measurements: RBW = 1MHz, VBW = 3 MHz, Sweep: Auto.
3. Average measurements: RBW = 1MHz, VBW = 10 Hz, Sweep: Auto.
4. “ \* ”, means this data is the worst emission level.
5. Measurement Level = Reading Level + Correct Factor.
6. The average measurement was not performed when the peak measured data under the limit of average detection.

Product : Intel® Dual Band Wireless-AC 8260  
 Test Item : Band Edge  
 Test Site : No.3 OATS  
 Test Mode : Mode 1 SISO A: Transmit (802.11g 6Mbps)

**RF Radiated Measurement (Vertical):**

Channel No.	Frequency (MHz)	Correct Factor (dB)	Reading Level (dBuV)	Emission Level (dBuV/m)	Peak Limit (dBuV/m)	Average Limit (dBuV/m)	Result
12 (Peak)	2470.100	32.520	70.407	102.927	--	--	Pass
12 (Peak)	2483.500	32.586	35.054	67.639	74.00	54.00	Pass
12 (Average)	2469.100	32.514	59.939	92.454	--	--	Pass
12 (Average)	2483.500	32.586	17.290	49.875	74.00	54.00	Pass

**Figure Channel 12: Vertical (Peak)**

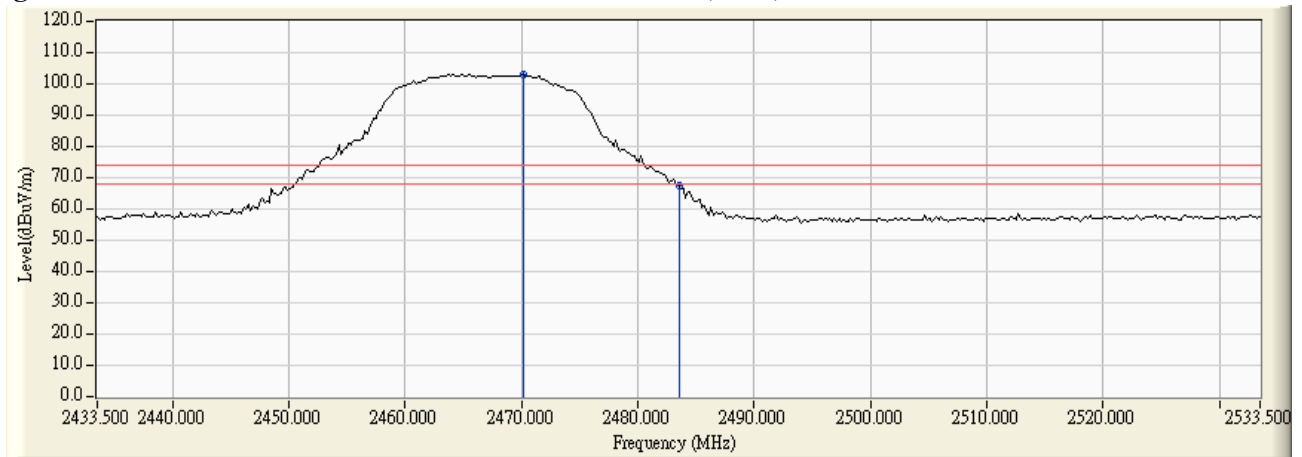

**Figure Channel 12: Vertical (Average)**

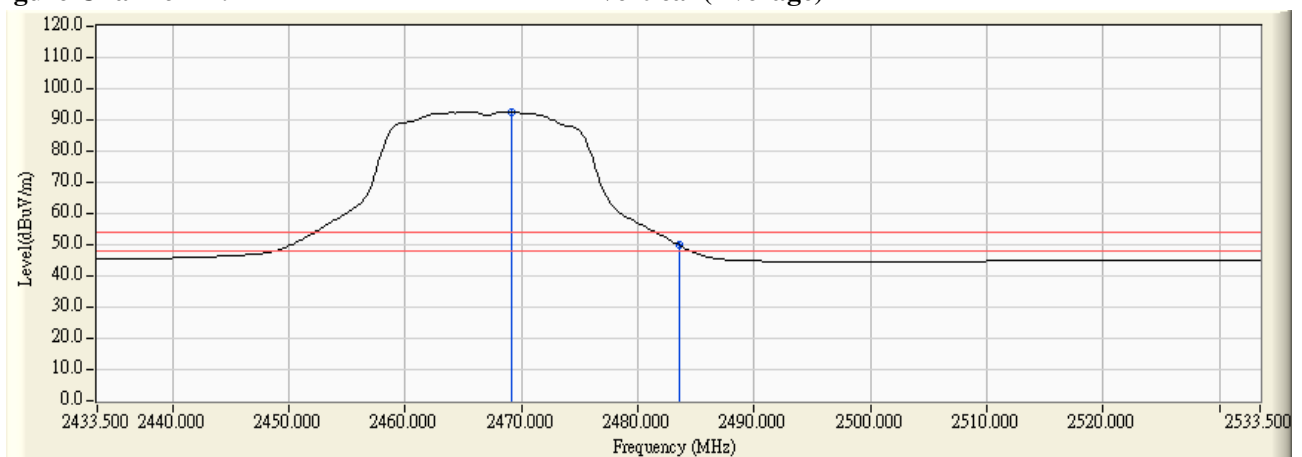

Note:

1. All readings above 1GHz are performed with peak and/or average measurements as necessary.
2. Peak measurements: RBW = 1MHz, VBW = 3 MHz, Sweep: Auto.
3. Average measurements: RBW = 1MHz, VBW = 10 Hz, Sweep: Auto.
4. “ \* ”, means this data is the worst emission level.
5. Measurement Level = Reading Level + Correct Factor.
6. The average measurement was not performed when the peak measured data under the limit of average detection.

Product : Intel® Dual Band Wireless-AC 8260  
 Test Item : Band Edge  
 Test Site : No.3 OATS  
 Test Mode : Mode 1 SISO A: Transmit - 802.11n-20BW\_7.2Mbps(2.4G Band)

**RF Radiated Measurement (Horizontal):**

Channel No.	Frequency (MHz)	Correct Factor (dB)	Reading Level (dBuV)	Emission Level (dBuV/m)	Peak Limit (dBuV/m)	Average Limit (dBuV/m)	Result
01 (Peak)	2390.000	33.739	38.196	71.935	74.00	54.00	Pass
01 (Peak)	2400.000	33.752	55.253	89.004	74.00	54.00	Pass
01 (Peak)	2415.000	33.779	76.780	110.559	--	--	Pass
01 (Average)	2390.000	33.739	18.777	52.516	74.00	54.00	Pass
01 (Average)	2400.000	33.752	36.826	70.577	74.00	54.00	Pass
01 (Average)	2414.400	33.778	65.952	99.730	--	--	Pass

**Figure Channel 01: Horizontal (Peak)**

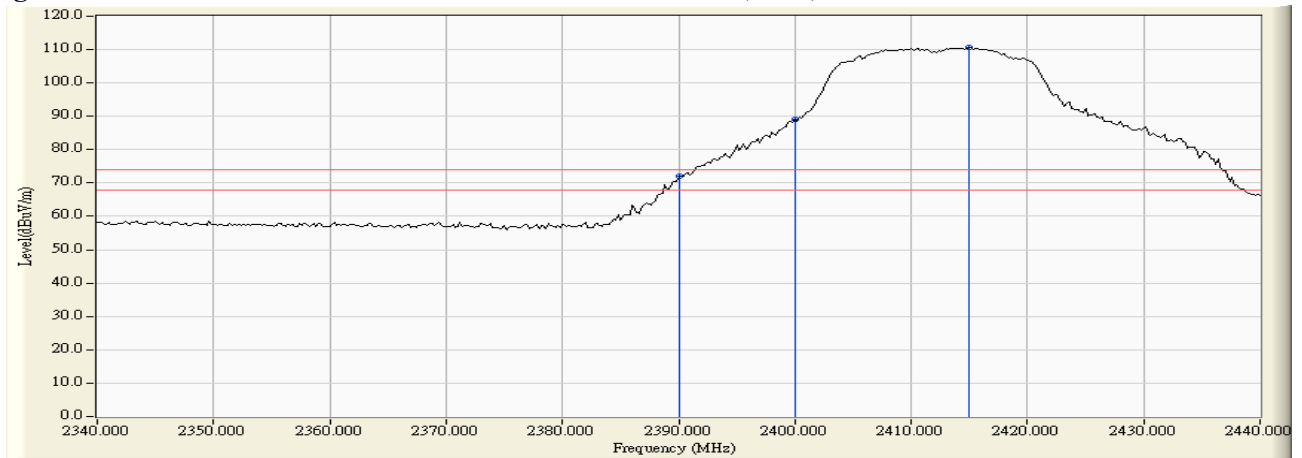

**Figure Channel 01: Horizontal (Average)**

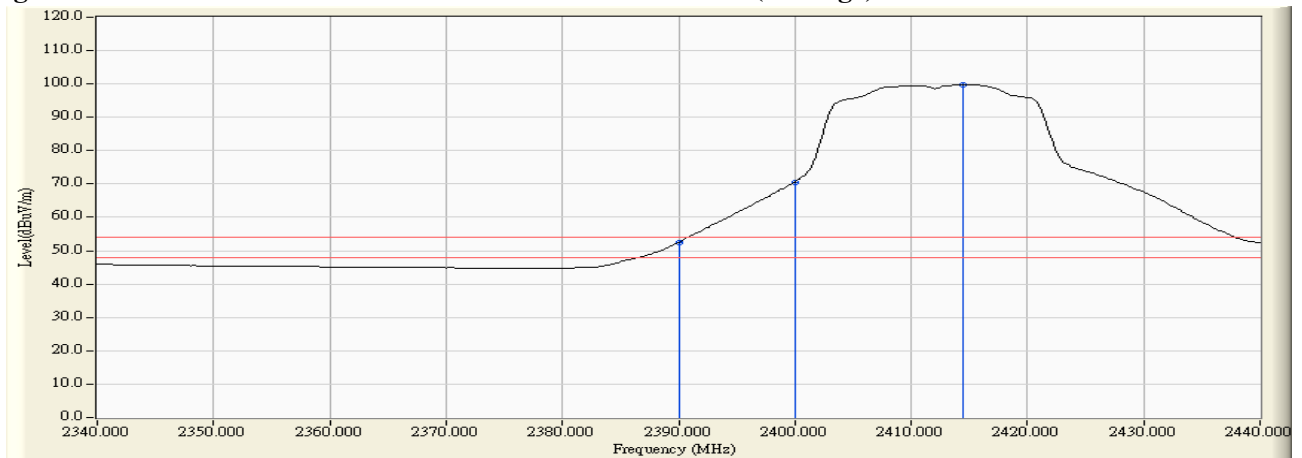

Note:

1. All readings above 1GHz are performed with peak and/or average measurements as necessary.
2. Peak measurements: RBW = 1MHz, VBW = 3 MHz, Sweep: Auto.
3. Average measurements: RBW = 1MHz, VBW = 10 Hz, Sweep: Auto.
4. “ \* ”, means this data is the worst emission level.
5. Measurement Level = Reading Level + Correct Factor.
6. The average measurement was not performed when the peak measured data under the limit of average detection.

Product : Intel® Dual Band Wireless-AC 8260  
 Test Item : Band Edge  
 Test Site : No.3 OATS  
 Test Mode : Mode 1 SISO A: Transmit - 802.11n-20BW\_7.2Mbps(2.4G Band)

**RF Radiated Measurement (Vertical):**

Channel No.	Frequency (MHz)	Correct Factor (dB)	Reading Level (dBuV)	Emission Level (dBuV/m)	Peak Limit (dBuV/m)	Average Limit (dBuV/m)	Result
01 (Peak)	2390.000	32.267	35.791	68.058	74.00	54.00	Pass
01 (Peak)	2400.000	32.241	51.908	84.149	74.00	54.00	Pass
01 (Peak)	2414.200	32.259	75.174	107.433	--	--	Pass
01 (Average)	2390.000	32.267	17.225	49.492	74.00	54.00	Pass
01 (Average)	2400.000	32.241	34.834	67.075	74.00	54.00	Pass
01 (Average)	2414.400	32.260	64.104	96.364	--	--	Pass

**Figure Channel 01:**

**Vertical (Peak)**

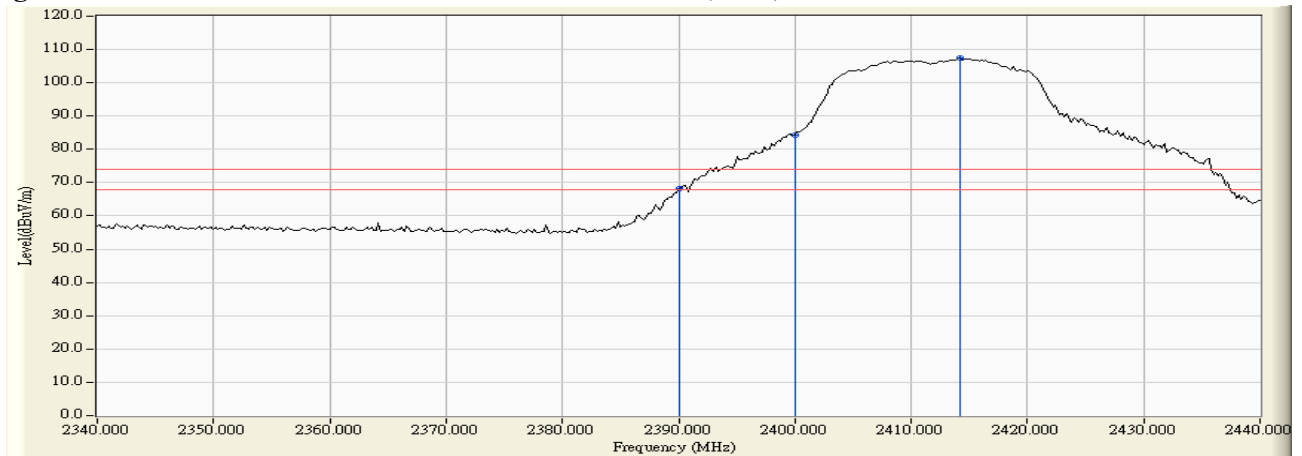

**Figure Channel 01:**

**Vertical (Average)**

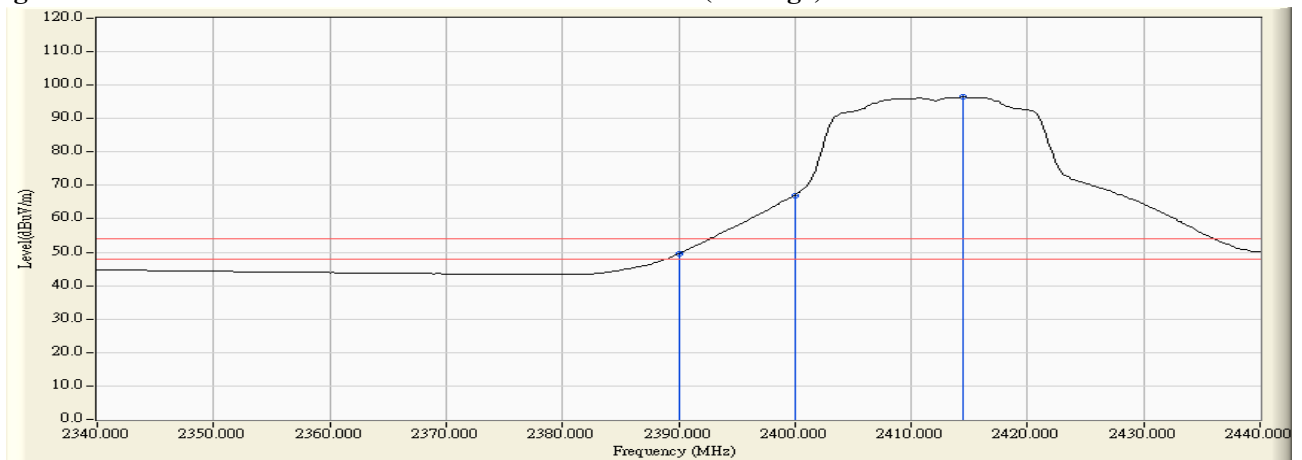

Note:

1. All readings above 1GHz are performed with peak and/or average measurements as necessary.
2. Peak measurements: RBW = 1MHz, VBW = 3 MHz, Sweep: Auto.
3. Average measurements: RBW = 1MHz, VBW = 10 Hz, Sweep: Auto.
4. “ \* ”, means this data is the worst emission level.
5. Measurement Level = Reading Level + Correct Factor.
6. The average measurement was not performed when the peak measured data under the limit of average detection.



Product : Intel® Dual Band Wireless-AC 8260  
 Test Item : Band Edge  
 Test Site : No.3 OATS  
 Test Mode : Mode 1 SISO A: Transmit - 802.11n-20BW\_7.2Mbps(2.4G Band)

**RF Radiated Measurement (Horizontal):**

Channel No.	Frequency (MHz)	Correct Factor (dB)	Reading Level (dBuV)	Emission Level (dBuV/m)	Peak Limit (dBuV/m)	Average Limit (dBuV/m)	Result
10 (Peak)	2453.900	33.872	79.156	113.028	--	--	Pass
10 (Peak)	2483.500	33.951	33.701	67.651	74.00	54.00	Pass
10 (Average)	2455.300	33.876	67.602	101.478	--	--	Pass
10 (Average)	2483.500	33.951	18.416	52.366	74.00	54.00	Pass

**Figure Channel 10: Horizontal (Peak)**

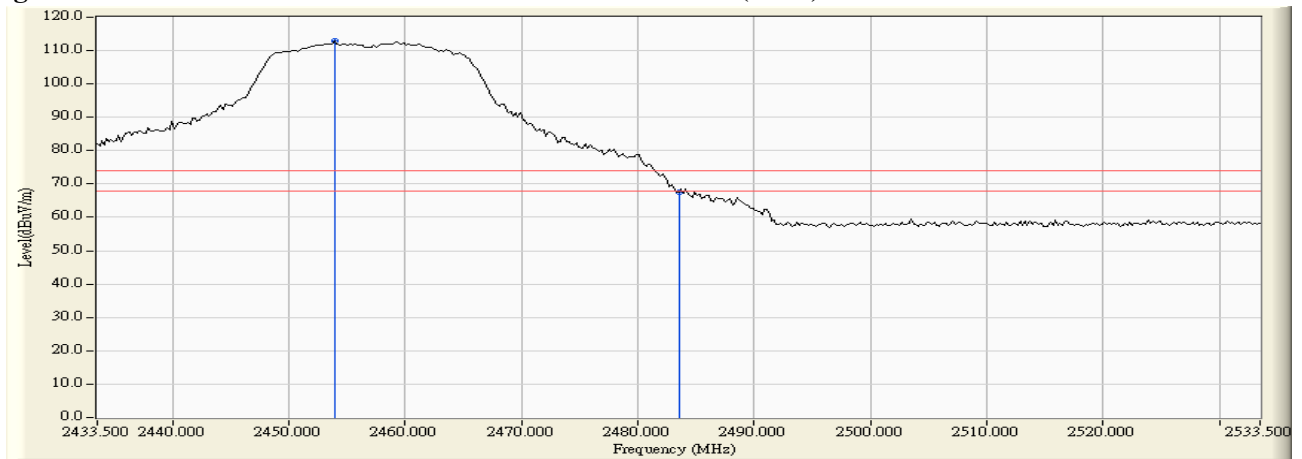

**Figure Channel 10: Horizontal (Average)**

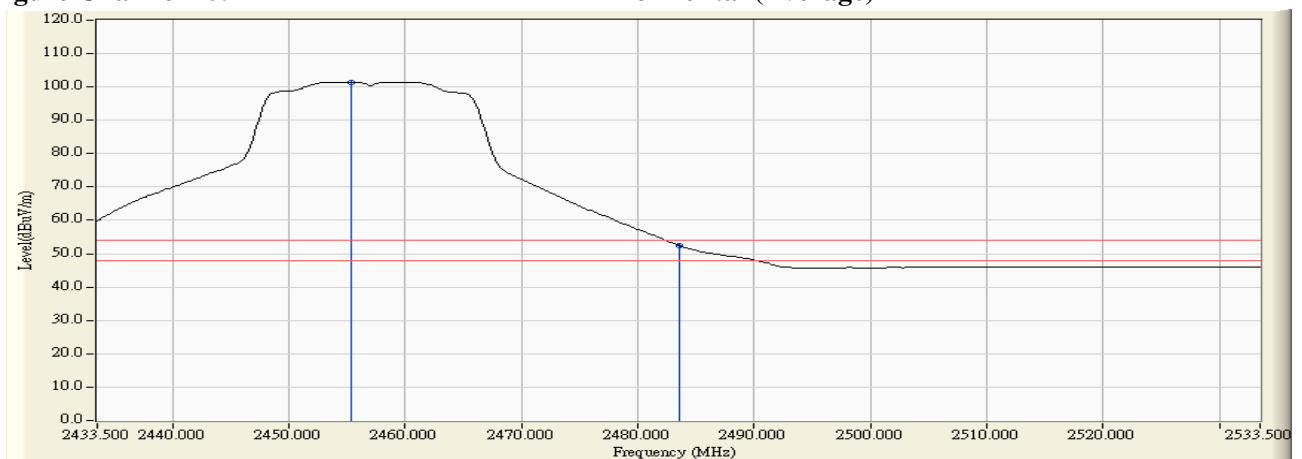

Note:

1. All readings above 1GHz are performed with peak and/or average measurements as necessary.
2. Peak measurements: RBW = 1MHz, VBW = 3 MHz, Sweep: Auto.
3. Average measurements: RBW = 1MHz, VBW = 10 Hz, Sweep: Auto.
4. “ \* ”, means this data is the worst emission level.
5. Measurement Level = Reading Level + Correct Factor.
6. The average measurement was not performed when the peak measured data under the limit of average detection.

Product : Intel® Dual Band Wireless-AC 8260  
 Test Item : Band Edge  
 Test Site : No.3 OATS  
 Test Mode : Mode 1 SISO A: Transmit - 802.11n-20BW\_7.2Mbps(2.4G Band)

**RF Radiated Measurement (Vertical):**

Channel No.	Frequency (MHz)	Correct Factor (dB)	Reading Level (dBuV)	Emission Level (dBuV/m)	Peak Limit (dBuV/m)	Average Limit (dBuV/m)	Result
10 (Peak)	2459.700	32.469	76.583	109.052	--	--	Pass
10 (Peak)	2483.500	32.586	32.850	65.435	74.00	54.00	Pass
10 (Average)	2455.300	32.449	65.983	98.431	--	--	Pass
10 (Average)	2483.500	32.586	17.424	50.009	74.00	54.00	Pass

**Figure Channel 10: Vertical (Peak)**

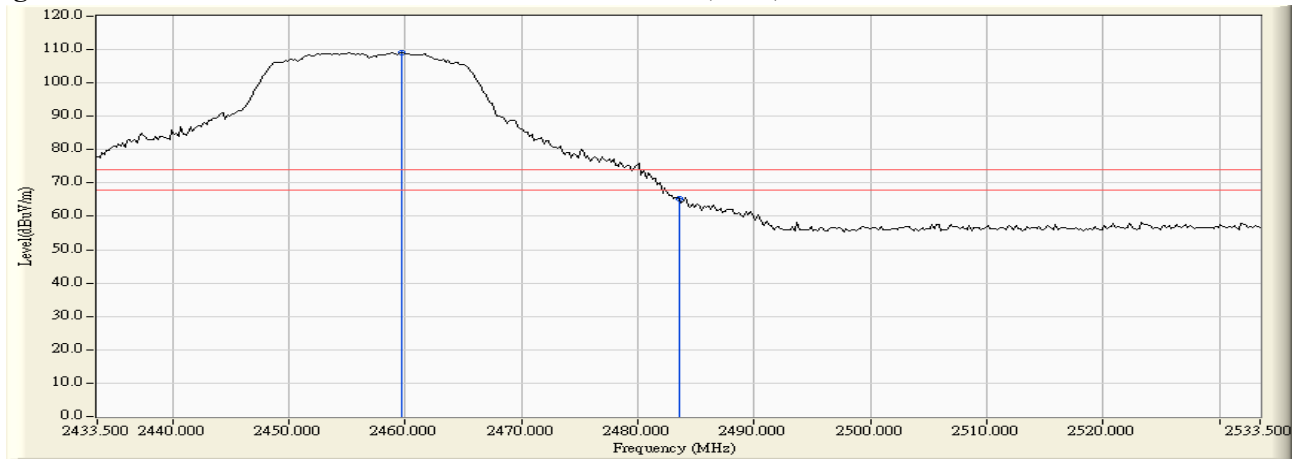

**Figure Channel 10: Vertical (Average)**

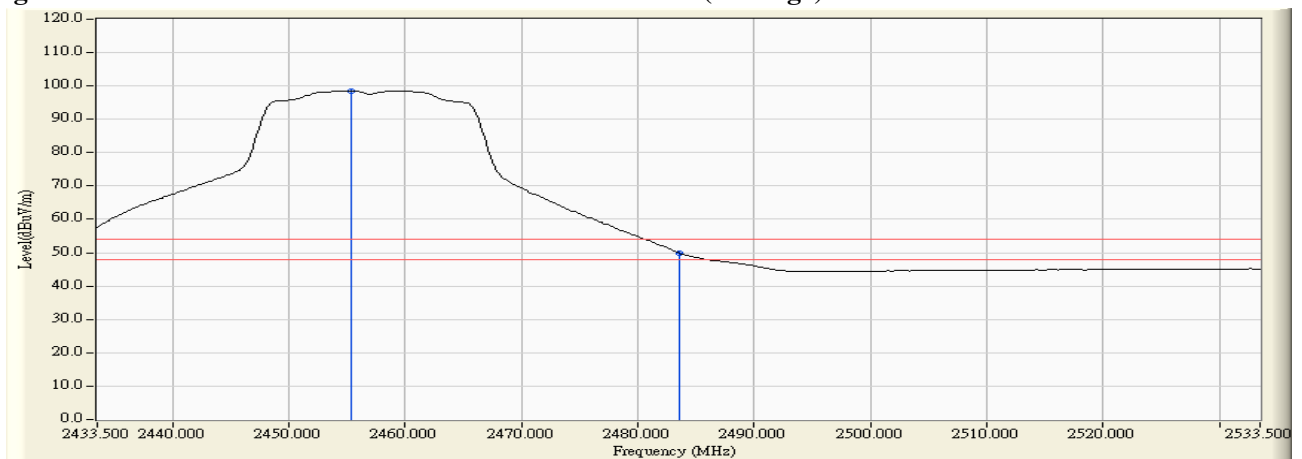

Note:

1. All readings above 1GHz are performed with peak and/or average measurements as necessary.
2. Peak measurements: RBW = 1MHz, VBW = 3 MHz, Sweep: Auto.
3. Average measurements: RBW = 1MHz, VBW = 10 Hz, Sweep: Auto.
4. “ \* ”, means this data is the worst emission level.
5. Measurement Level = Reading Level + Correct Factor.
6. The average measurement was not performed when the peak measured data under the limit of average detection.

Product : Intel® Dual Band Wireless-AC 8260  
 Test Item : Band Edge  
 Test Site : No.3 OATS  
 Test Mode : Mode 1 SISO A: Transmit - 802.11n-20BW\_7.2Mbps(2.4G Band)

**RF Radiated Measurement (Horizontal):**

Channel No.	Frequency (MHz)	Correct Factor (dB)	Reading Level (dBuV)	Emission Level (dBuV/m)	Peak Limit (dBuV/m)	Average Limit (dBuV/m)	Result
11 (Peak)	2458.900	33.885	77.341	111.226	--	--	Pass
11 (Peak)	2483.500	33.951	37.110	71.060	74.00	54.00	Pass
11 (Average)	2465.300	33.901	66.037	99.938	--	--	Pass
11 (Average)	2483.500	33.951	19.442	53.392	74.00	54.00	Pass

**Figure Channel 11: Horizontal (Peak)**

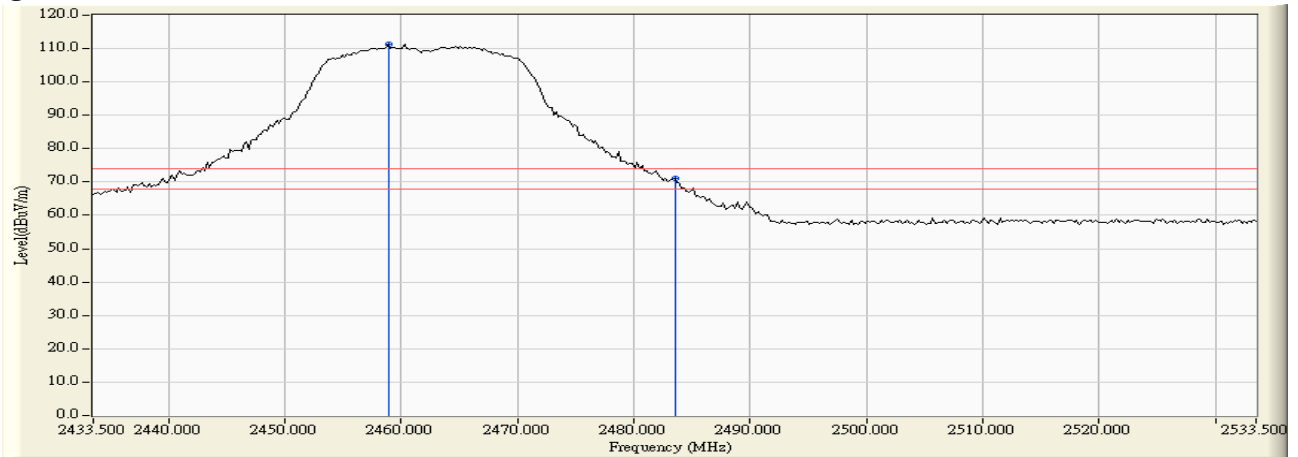

**Figure Channel 11: Horizontal (Average)**

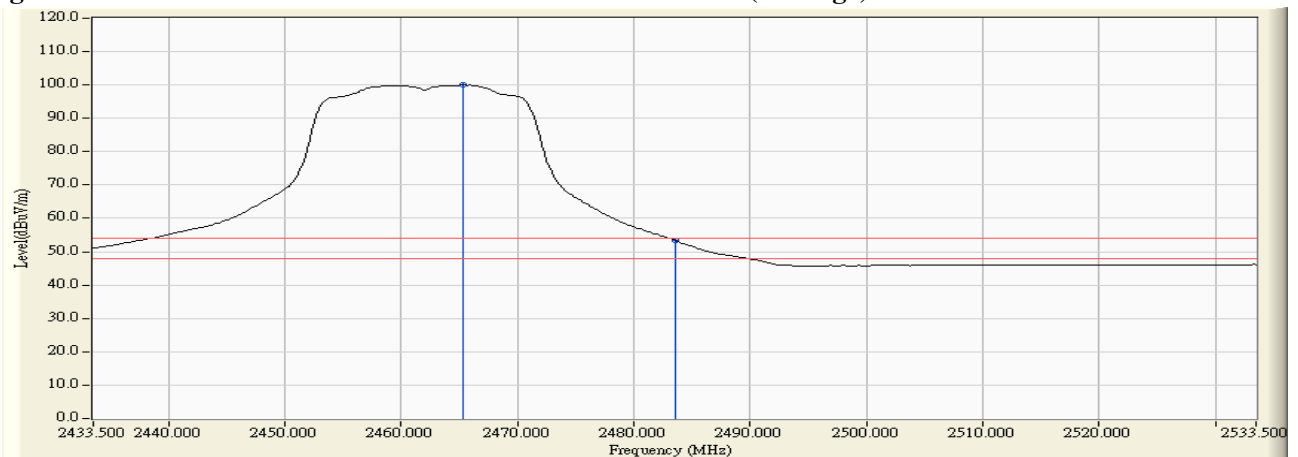

Note:

1. All readings above 1GHz are performed with peak and/or average measurements as necessary.
2. Peak measurements: RBW = 1MHz, VBW = 3 MHz, Sweep: Auto.
3. Average measurements: RBW = 1MHz, VBW = 10 Hz, Sweep: Auto.
4. “ \* ”, means this data is the worst emission level.
5. Measurement Level = Reading Level + Correct Factor.
6. The average measurement was not performed when the peak measured data under the limit of average detection.

Product : Intel® Dual Band Wireless-AC 8260  
 Test Item : Band Edge  
 Test Site : No.3 OATS  
 Test Mode : Mode 1 SISO A: Transmit - 802.11n-20BW\_7.2Mbps(2.4G Band)

**RF Radiated Measurement (Vertical):**

Channel No.	Frequency (MHz)	Correct Factor (dB)	Reading Level (dBuV)	Emission Level (dBuV/m)	Peak Limit (dBuV/m)	Average Limit (dBuV/m)	Result
11 (Peak)	2464.300	32.492	75.149	107.641	--	--	Pass
11 (Peak)	2483.500	32.586	34.195	66.780	74.00	54.00	Pass
11 (Average)	2464.700	32.494	64.244	96.737	--	--	Pass
11 (Average)	2483.500	32.586	17.841	50.426	74.00	54.00	Pass

**Figure Channel 11: Vertical (Peak)**

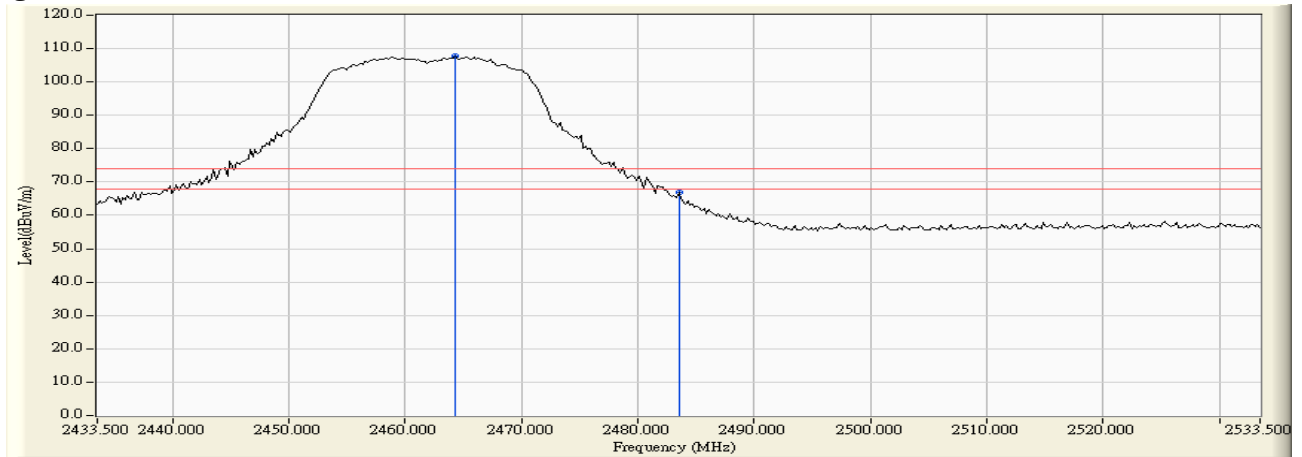

**Figure Channel 11: Vertical (Average)**

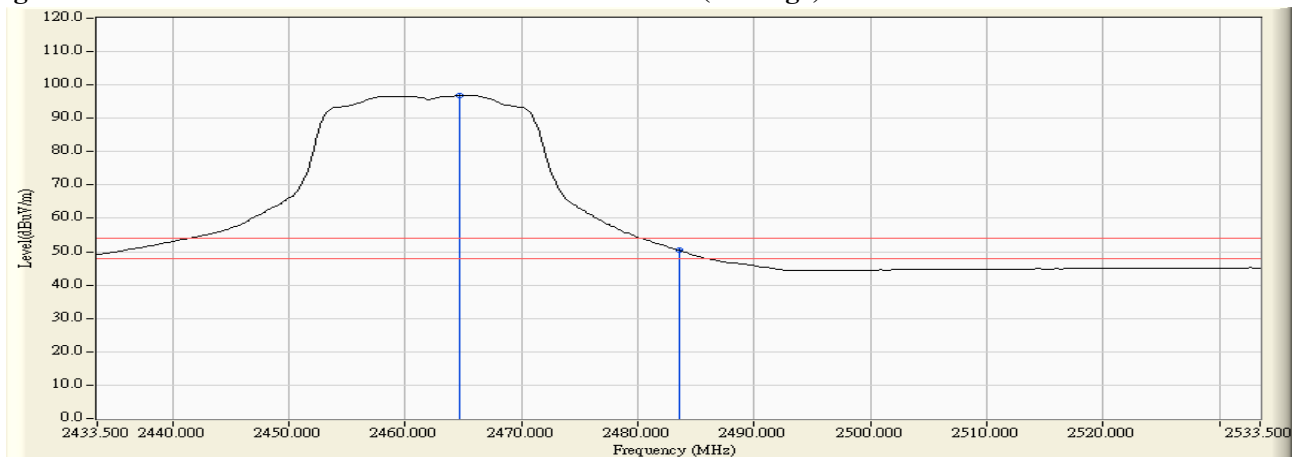

Note:

1. All readings above 1GHz are performed with peak and/or average measurements as necessary.
2. Peak measurements: RBW = 1MHz, VBW = 3 MHz, Sweep: Auto.
3. Average measurements: RBW = 1MHz, VBW = 10 Hz, Sweep: Auto.
4. “ \* ”, means this data is the worst emission level.
5. Measurement Level = Reading Level + Correct Factor.
6. The average measurement was not performed when the peak measured data under the limit of average detection.



Product : Intel® Dual Band Wireless-AC 8260  
 Test Item : Band Edge  
 Test Site : No.3 OATS  
 Test Mode : Mode 1 SISO A: Transmit - 802.11n-20BW\_7.2Mbps(2.4G Band)

**RF Radiated Measurement (Horizontal):**

Channel No.	Frequency (MHz)	Correct Factor (dB)	Reading Level (dBuV)	Emission Level (dBuV/m)	Peak Limit (dBuV/m)	Average Limit (dBuV/m)	Result
12 (Peak)	2463.700	33.897	72.258	106.155	--	--	Pass
12 (Peak)	2483.500	33.951	36.883	70.833	74.00	54.00	Pass
12 (Average)	2468.500	33.909	61.349	95.259	--	--	Pass
12 (Average)	2483.500	33.951	18.886	52.836	74.00	54.00	Pass

**Figure Channel 12: Horizontal (Peak)**

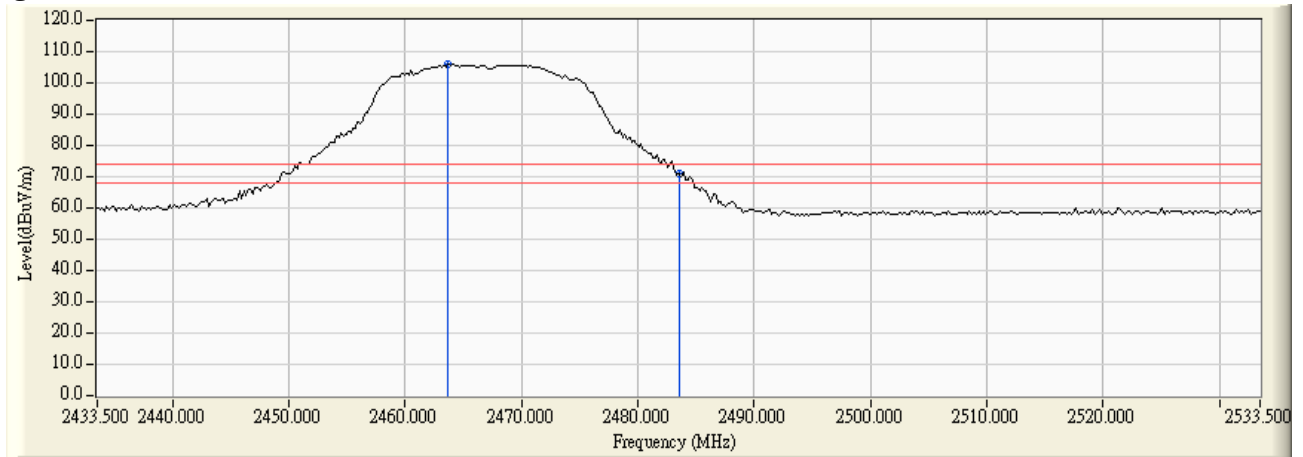

**Figure Channel 12: Horizontal (Average)**

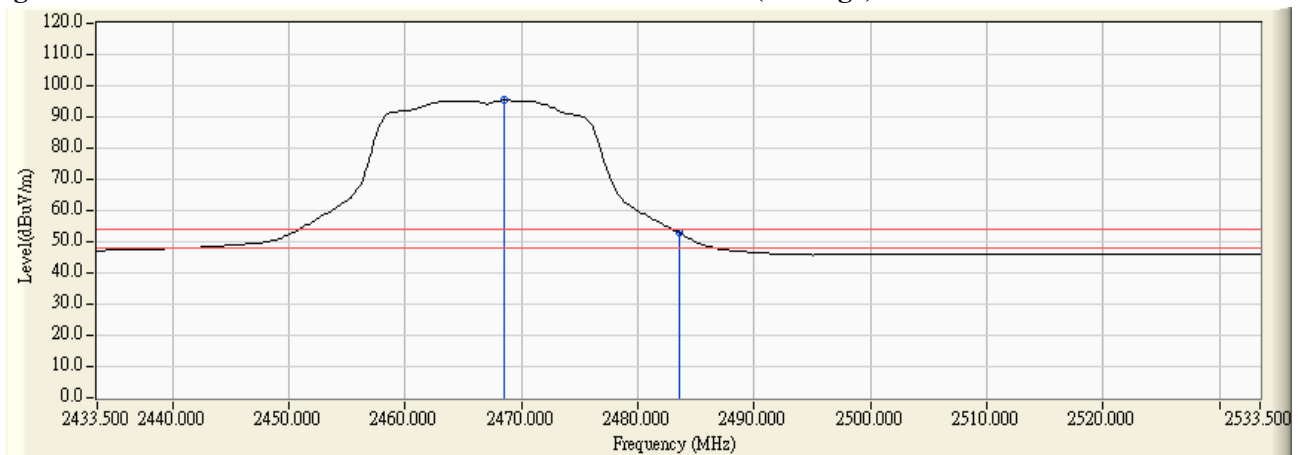

Note:

1. All readings above 1GHz are performed with peak and/or average measurements as necessary.
2. Peak measurements: RBW = 1MHz, VBW = 3 MHz, Sweep: Auto.
3. Average measurements: RBW = 1MHz, VBW = 10 Hz, Sweep: Auto.
4. “ \* ”, means this data is the worst emission level.
5. Measurement Level = Reading Level + Correct Factor.
6. The average measurement was not performed when the peak measured data under the limit of average detection.

Product : Intel® Dual Band Wireless-AC 8260  
 Test Item : Band Edge  
 Test Site : No.3 OATS  
 Test Mode : Mode 1 SISO A: Transmit - 802.11n-20BW\_7.2Mbps(2.4G Band)

**RF Radiated Measurement (Vertical):**

Channel No.	Frequency (MHz)	Correct Factor (dB)	Reading Level (dBuV)	Emission Level (dBuV/m)	Peak Limit (dBuV/m)	Average Limit (dBuV/m)	Result
12 (Peak)	2465.300	32.496	70.938	103.434	--	--	Pass
12 (Peak)	2483.500	32.586	32.718	65.303	74.00	54.00	Pass
12 (Peak)	2483.900	32.587	35.382	67.969	74.00	54.00	Pass
12 (Average)	2468.900	32.514	59.355	91.869	--	--	Pass
12 (Average)	2483.500	32.586	17.077	49.662	74.00	54.00	Pass

**Figure Channel 12: Vertical (Peak)**

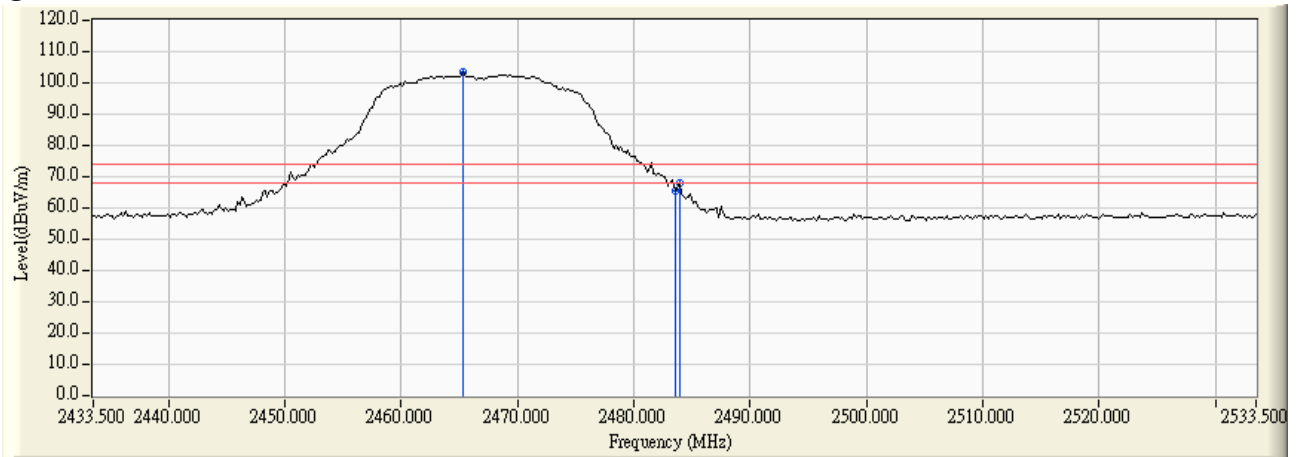

**Figure Channel 12: Vertical (Average)**

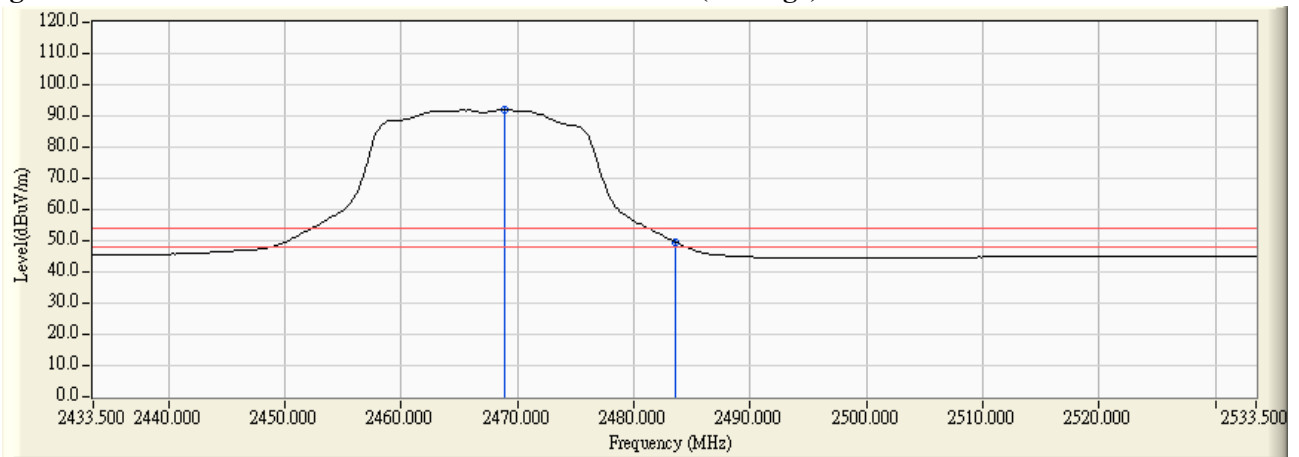

Note:

1. All readings above 1GHz are performed with peak and/or average measurements as necessary.
2. Peak measurements: RBW = 1MHz, VBW = 3 MHz, Sweep: Auto.
3. Average measurements: RBW = 1MHz, VBW = 10 Hz, Sweep: Auto.
4. “ \* ”, means this data is the worst emission level.
5. Measurement Level = Reading Level + Correct Factor.
6. The average measurement was not performed when the peak measured data under the limit of average detection.

Product : Intel® Dual Band Wireless-AC 8260  
 Test Item : Band Edge  
 Test Site : No.3 OATS  
 Test Mode : Mode 1 SISO A: Transmit - 802.11n-40BW\_15Mbps(2.4G Band)

**RF Radiated Measurement (Horizontal):**

Channel No.	Frequency (MHz)	Correct Factor (dB)	Reading Level (dBuV)	Emission Level (dBuV/m)	Peak Limit (dBuV/m)	Average Limit (dBuV/m)	Result
03 (Peak)	2390.000	33.739	33.172	66.911	74.00	54.00	Pass
03 (Peak)	2400.000	33.752	46.528	80.279	74.00	54.00	Pass
03 (Peak)	2433.200	33.822	71.613	105.435	--	--	Pass
03 (Average)	2390.000	33.739	19.426	53.165	74.00	54.00	Pass
03 (Average)	2400.000	33.752	32.982	66.733	74.00	54.00	Pass
03 (Average)	2433.400	33.823	59.582	93.404	--	--	Pass

**Figure Channel 03:**

**Horizontal (Peak)**

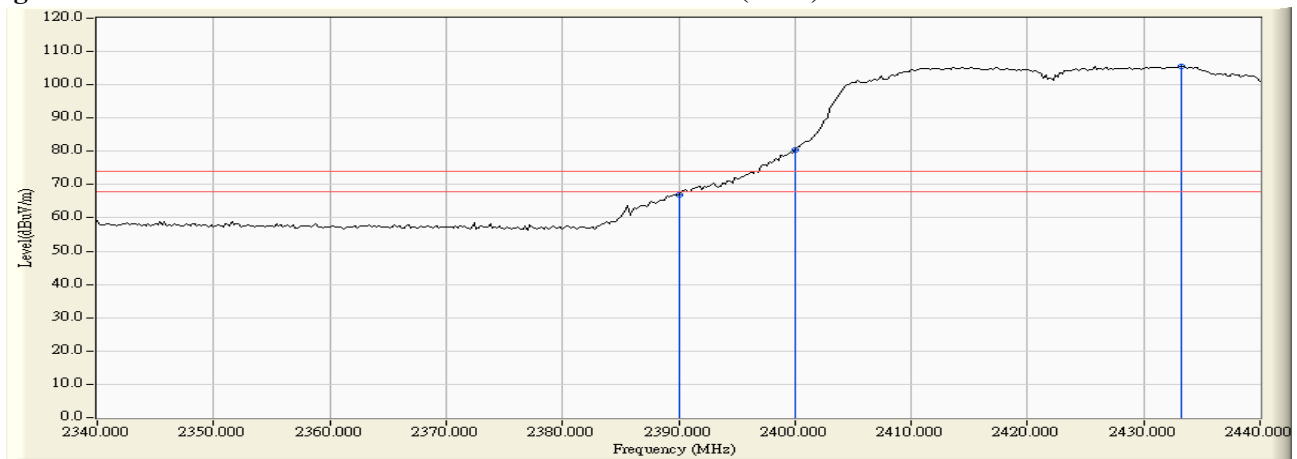

**Figure Channel 03:**

**Horizontal (Average)**

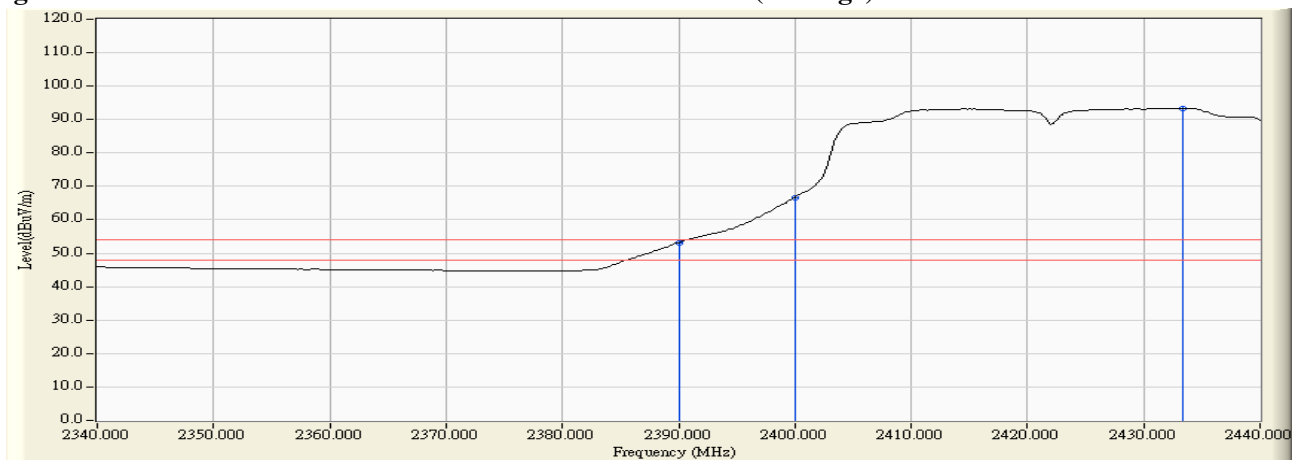

Note:

1. All readings above 1GHz are performed with peak and/or average measurements as necessary.
2. Peak measurements: RBW = 1MHz, VBW = 3 MHz, Sweep: Auto.
3. Average measurements: RBW = 1MHz, VBW = 10 Hz, Sweep: Auto.
4. “ \* ”, means this data is the worst emission level.
5. Measurement Level = Reading Level + Correct Factor.
6. The average measurement was not performed when the peak measured data under the limit of average detection.

Product : Intel® Dual Band Wireless-AC 8260  
 Test Item : Band Edge  
 Test Site : No.3 OATS  
 Test Mode : Mode 1 SISO A: Transmit - 802.11n-40BW\_15Mbps(2.4G Band)

**RF Radiated Measurement (Vertical):**

Channel No.	Frequency (MHz)	Correct Factor (dB)	Reading Level (dBuV)	Emission Level (dBuV/m)	Peak Limit (dBuV/m)	Average Limit (dBuV/m)	Result
03 (Peak)	2390.000	32.267	31.503	63.770	74.00	54.00	Pass
03 (Peak)	2400.000	32.241	44.625	76.866	74.00	54.00	Pass
03 (Peak)	2433.200	32.344	70.075	102.420	--	--	Pass
03 (Average)	2390.000	32.267	17.978	50.245	74.00	54.00	Pass
03 (Average)	2400.000	32.241	31.297	63.538	74.00	54.00	Pass
03 (Average)	2433.400	32.346	58.416	90.761	--	--	Pass

**Figure Channel 03:**

**Vertical (Peak)**

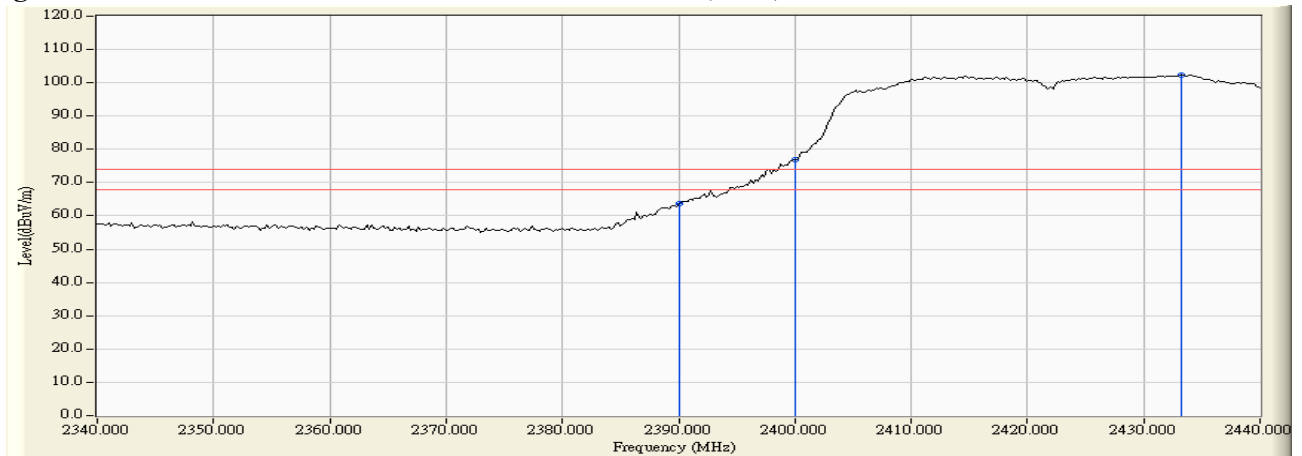

**Figure Channel 03:**

**Vertical (Average)**

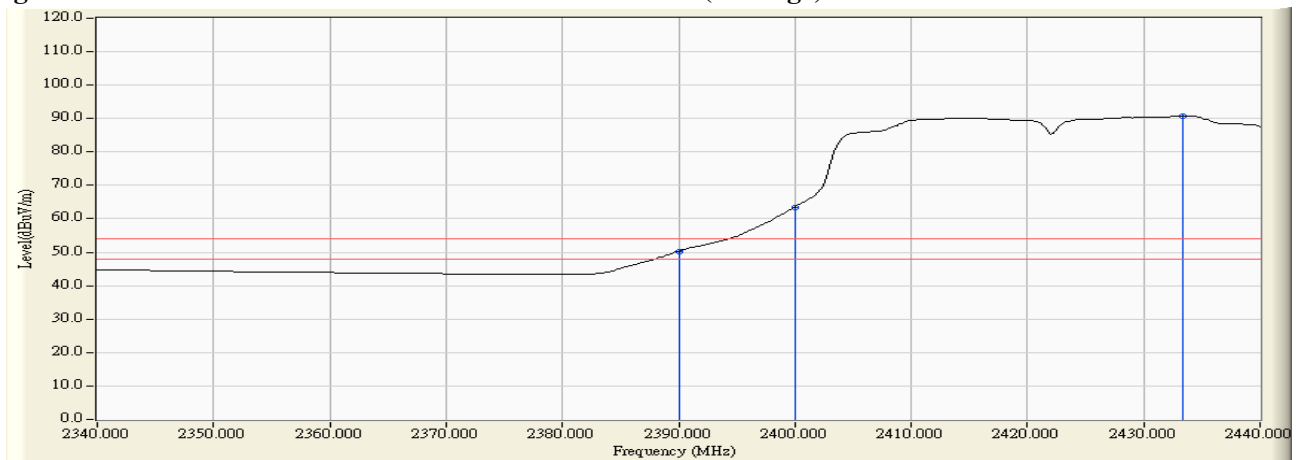

Note:

1. All readings above 1GHz are performed with peak and/or average measurements as necessary.
2. Peak measurements: RBW = 1MHz, VBW = 3 MHz, Sweep: Auto.
3. Average measurements: RBW = 1MHz, VBW = 10 Hz, Sweep: Auto.
4. “ \* ”, means this data is the worst emission level.
5. Measurement Level = Reading Level + Correct Factor.
6. The average measurement was not performed when the peak measured data under the limit of average detection.



Product : Intel® Dual Band Wireless-AC 8260  
 Test Item : Band Edge  
 Test Site : No.3 OATS  
 Test Mode : Mode 1 SISO A: Transmit - 802.11n-40BW\_15Mbps(2.4G Band)

**RF Radiated Measurement (Horizontal):**

Channel No.	Frequency (MHz)	Correct Factor (dB)	Reading Level (dBuV)	Emission Level (dBuV/m)	Peak Limit (dBuV/m)	Average Limit (dBuV/m)	Result
04 (Peak)	2390.000	33.739	31.975	65.714	74.00	54.00	Pass
04 (Peak)	2400.000	33.752	38.798	72.549	74.00	54.00	Pass
04 (Peak)	2437.400	33.832	72.564	106.396	--	--	Pass
04 (Average)	2390.000	33.739	18.589	52.328	74.00	54.00	Pass
04 (Average)	2400.000	33.752	25.213	58.964	74.00	54.00	Pass
04 (Average)	2438.200	33.833	60.773	94.607	--	--	Pass

**Figure Channel 04: Horizontal (Peak)**

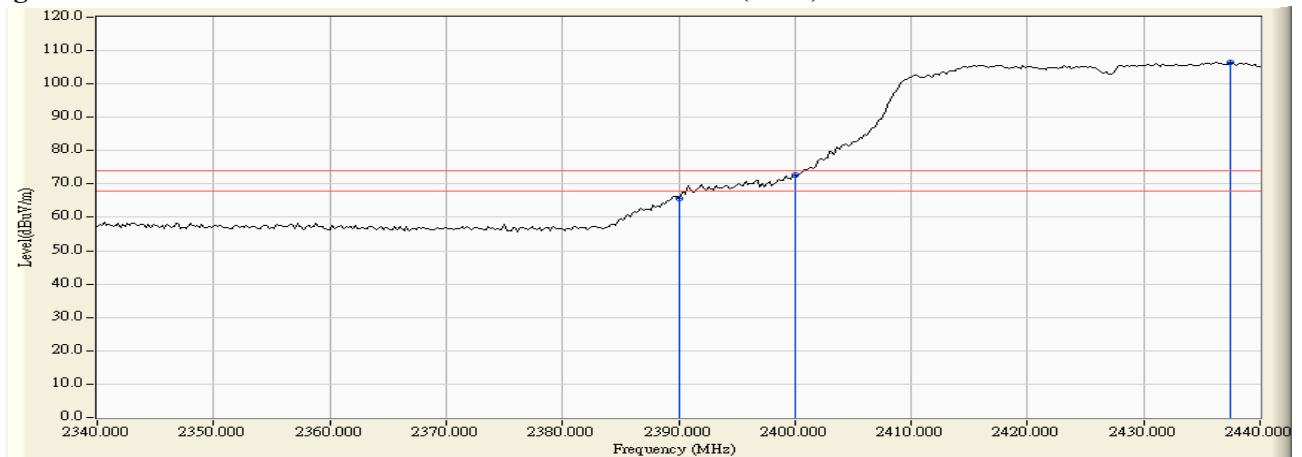

**Figure Channel 04: Horizontal (Average)**

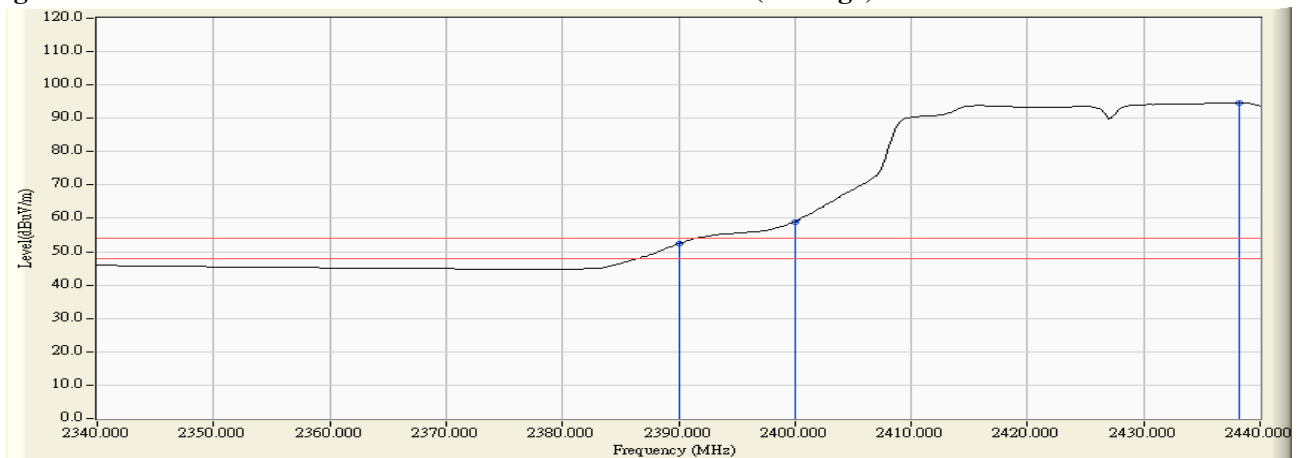

Note:

1. All readings above 1GHz are performed with peak and/or average measurements as necessary.
2. Peak measurements: RBW = 1MHz, VBW = 3 MHz, Sweep: Auto.
3. Average measurements: RBW = 1MHz, VBW = 10 Hz, Sweep: Auto.
4. “ \* ”, means this data is the worst emission level.
5. Measurement Level = Reading Level + Correct Factor.
6. The average measurement was not performed when the peak measured data under the limit of average detection.

Product : Intel® Dual Band Wireless-AC 8260  
 Test Item : Band Edge  
 Test Site : No.3 OATS  
 Test Mode : Mode 1 SISO A: Transmit - 802.11n-40BW\_15Mbps(2.4G Band)

**RF Radiated Measurement (Vertical):**

Channel No.	Frequency (MHz)	Correct Factor (dB)	Reading Level (dBuV)	Emission Level (dBuV/m)	Peak Limit (dBuV/m)	Average Limit (dBuV/m)	Result
04 (Peak)	2390.000	32.267	33.141	65.408	74.00	54.00	Pass
04 (Peak)	2400.000	32.241	37.927	70.168	74.00	54.00	Pass
04 (Peak)	2436.400	32.359	72.373	104.732	--	--	Pass
04 (Average)	2390.000	32.267	17.032	49.299	74.00	54.00	Pass
04 (Average)	2400.000	32.241	23.354	55.595	74.00	54.00	Pass
04 (Average)	2438.200	32.367	59.356	91.723	--	--	Pass

**Figure Channel 04:**

**Vertical (Peak)**

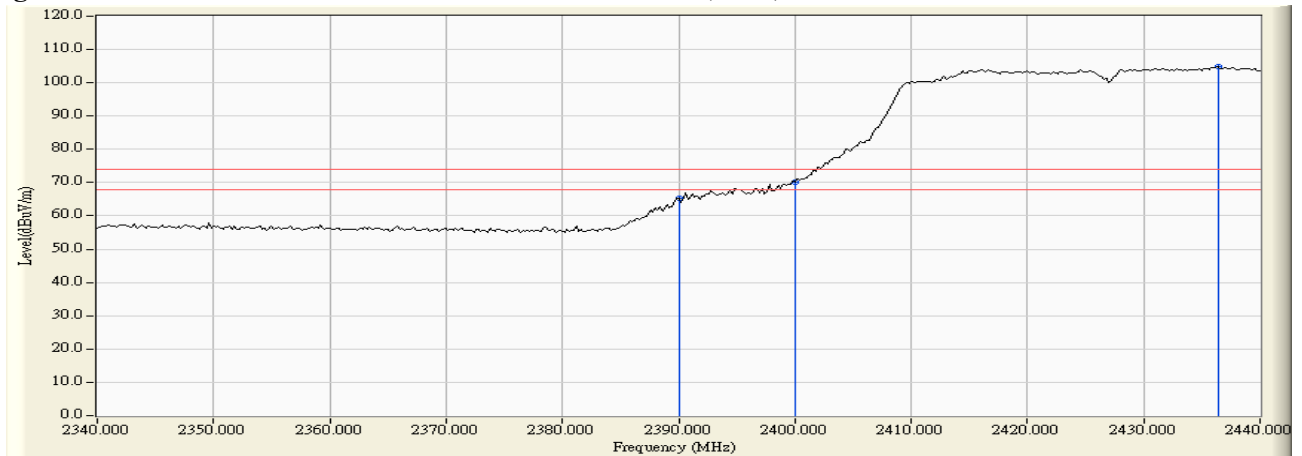

**Figure Channel 04:**

**Vertical (Average)**

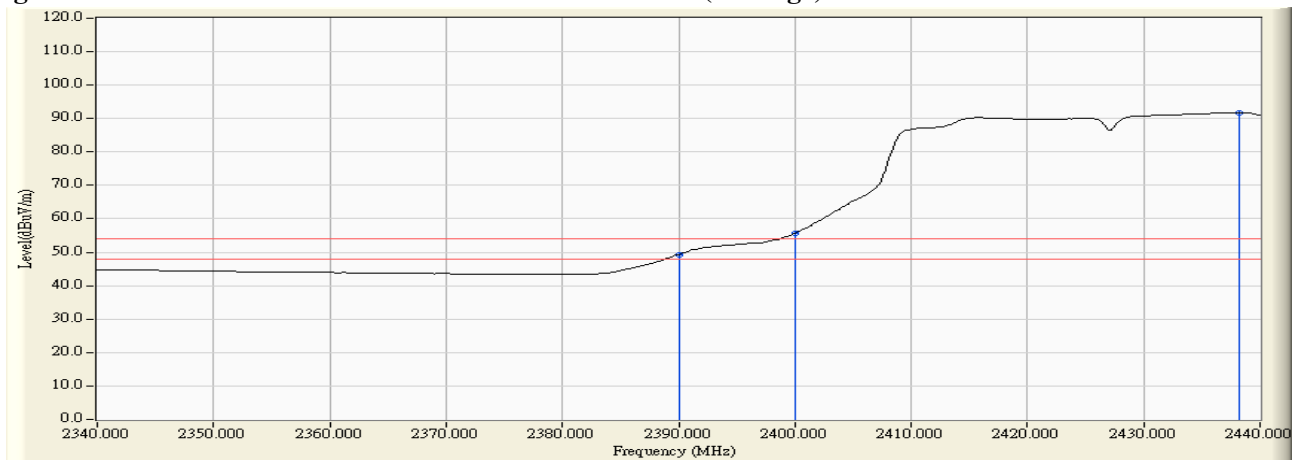

Note:

1. All readings above 1GHz are performed with peak and/or average measurements as necessary.
2. Peak measurements: RBW = 1MHz, VBW = 3 MHz, Sweep: Auto.
3. Average measurements: RBW = 1MHz, VBW = 10 Hz, Sweep: Auto.
4. “ \* ”, means this data is the worst emission level.
5. Measurement Level = Reading Level + Correct Factor.
6. The average measurement was not performed when the peak measured data under the limit of average detection.

Product : Intel® Dual Band Wireless-AC 8260  
 Test Item : Band Edge  
 Test Site : No.3 OATS  
 Test Mode : Mode 1 SISO A: Transmit - 802.11n-40BW\_15Mbps(2.4G Band)

**RF Radiated Measurement (Horizontal):**

Channel No.	Frequency (MHz)	Correct Factor (dB)	Reading Level (dBuV)	Emission Level (dBuV/m)	Peak Limit (dBuV/m)	Average Limit (dBuV/m)	Result
08 (Peak)	2436.900	33.831	75.848	109.679	--	--	Pass
08 (Peak)	2483.500	33.951	32.971	66.921	74.00	54.00	Pass
08 (Average)	2435.700	33.828	63.895	97.723	--	--	Pass
08 (Average)	2483.500	33.951	19.250	53.200	74.00	54.00	Pass

**Figure Channel 08: Horizontal (Peak)**

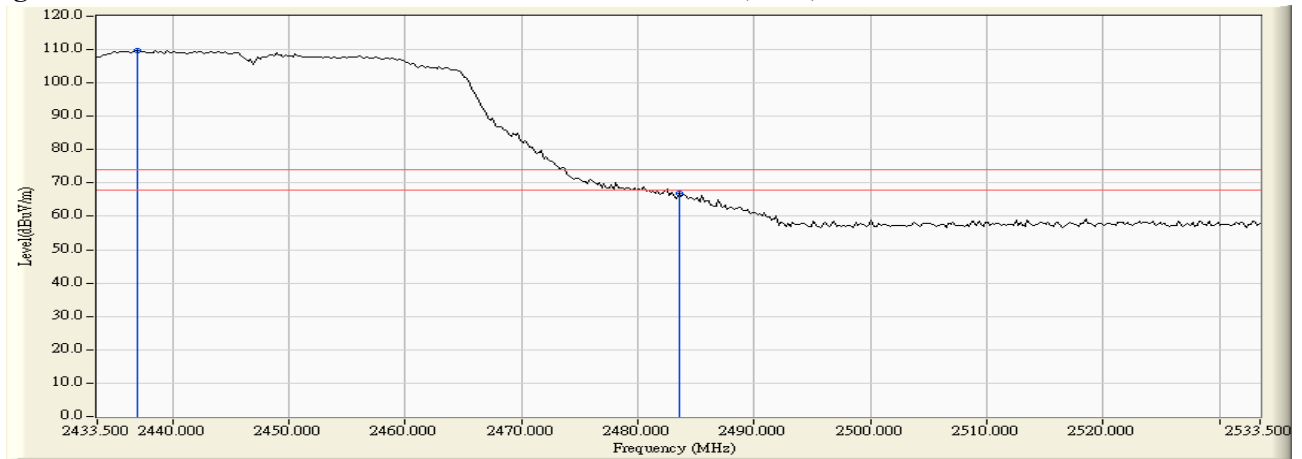

**Figure Channel 08: Horizontal (Average)**

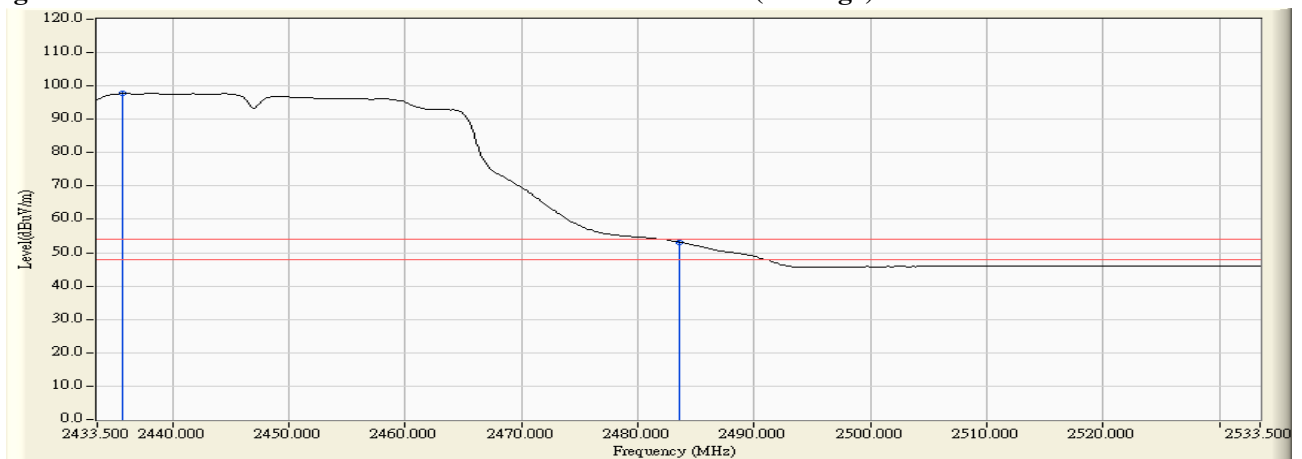

Note:

1. All readings above 1GHz are performed with peak and/or average measurements as necessary.
2. Peak measurements: RBW = 1MHz, VBW = 3 MHz, Sweep: Auto.
3. Average measurements: RBW = 1MHz, VBW = 10 Hz, Sweep: Auto.
4. “ \* ”, means this data is the worst emission level.
5. Measurement Level = Reading Level + Correct Factor.
6. The average measurement was not performed when the peak measured data under the limit of average detection.

Product : Intel® Dual Band Wireless-AC 8260  
 Test Item : Band Edge  
 Test Site : No.3 OATS  
 Test Mode : Mode 1 SISO A: Transmit - 802.11n-40BW\_15Mbps(2.4G Band)

**RF Radiated Measurement (Vertical):**

Channel No.	Frequency (MHz)	Correct Factor (dB)	Reading Level (dBuV)	Emission Level (dBuV/m)	Peak Limit (dBuV/m)	Average Limit (dBuV/m)	Result
08 (Peak)	2436.900	32.362	73.325	105.686	--	--	Pass
08 (Peak)	2483.500	32.586	30.220	62.805	74.00	54.00	Pass
08 (Average)	2444.700	32.397	61.475	93.872	--	--	Pass
08 (Average)	2483.500	32.586	17.170	49.755	74.00	54.00	Pass

**Figure Channel 08: Vertical (Peak)**

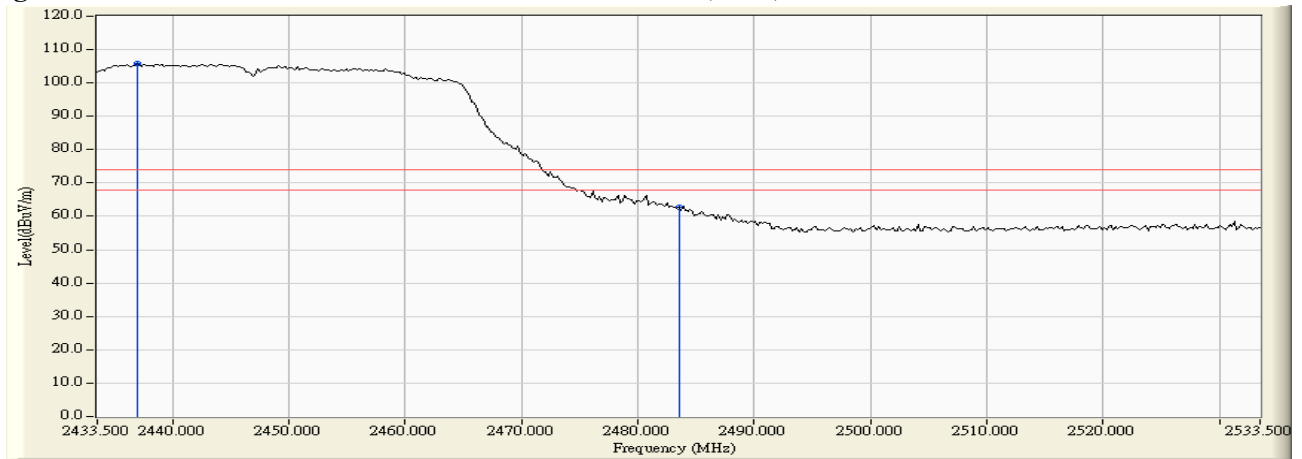

**Figure Channel 08: Vertical (Average)**

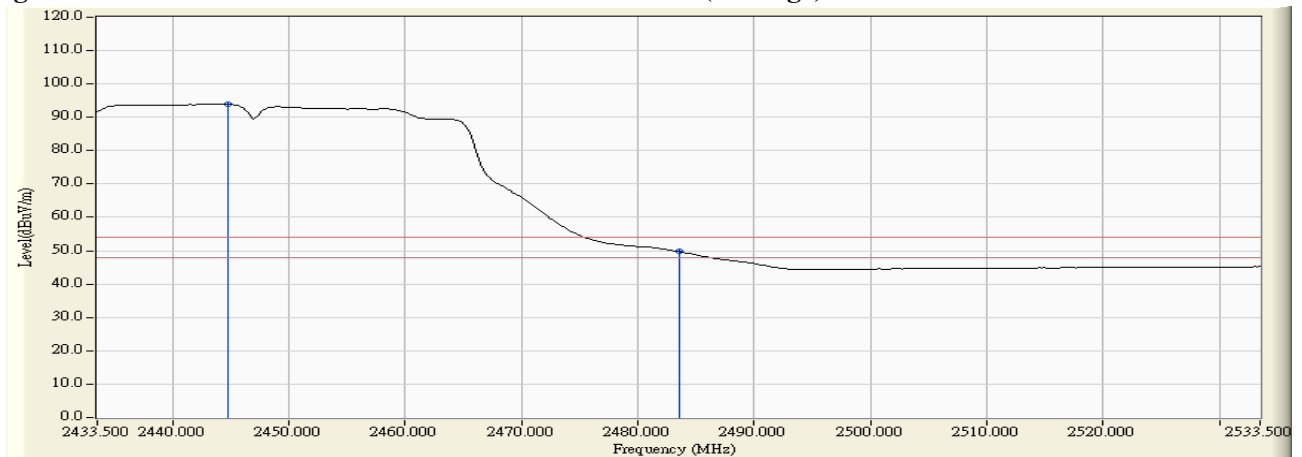

Note:

1. All readings above 1GHz are performed with peak and/or average measurements as necessary.
2. Peak measurements: RBW = 1MHz, VBW = 3 MHz, Sweep: Auto.
3. Average measurements: RBW = 1MHz, VBW = 10 Hz, Sweep: Auto.
4. “ \* ”, means this data is the worst emission level.
5. Measurement Level = Reading Level + Correct Factor.
6. The average measurement was not performed when the peak measured data under the limit of average detection.



Product : Intel® Dual Band Wireless-AC 8260  
 Test Item : Band Edge  
 Test Site : No.3 OATS  
 Test Mode : Mode 1 SISO A: Transmit - 802.11n-40BW\_15Mbps(2.4G Band)

**RF Radiated Measurement (Horizontal):**

Channel No.	Frequency (MHz)	Correct Factor (dB)	Reading Level (dBuV)	Emission Level (dBuV/m)	Peak Limit (dBuV/m)	Average Limit (dBuV/m)	Result
09 (Peak)	2444.500	33.848	73.089	106.937	--	--	Pass
09 (Peak)	2483.500	33.951	33.734	67.684	74.00	54.00	Pass
09 (Average)	2443.300	33.845	61.143	94.988	--	--	Pass
09 (Average)	2483.500	33.951	19.314	53.264	74.00	54.00	Pass

**Figure Channel 09: Horizontal (Peak)**

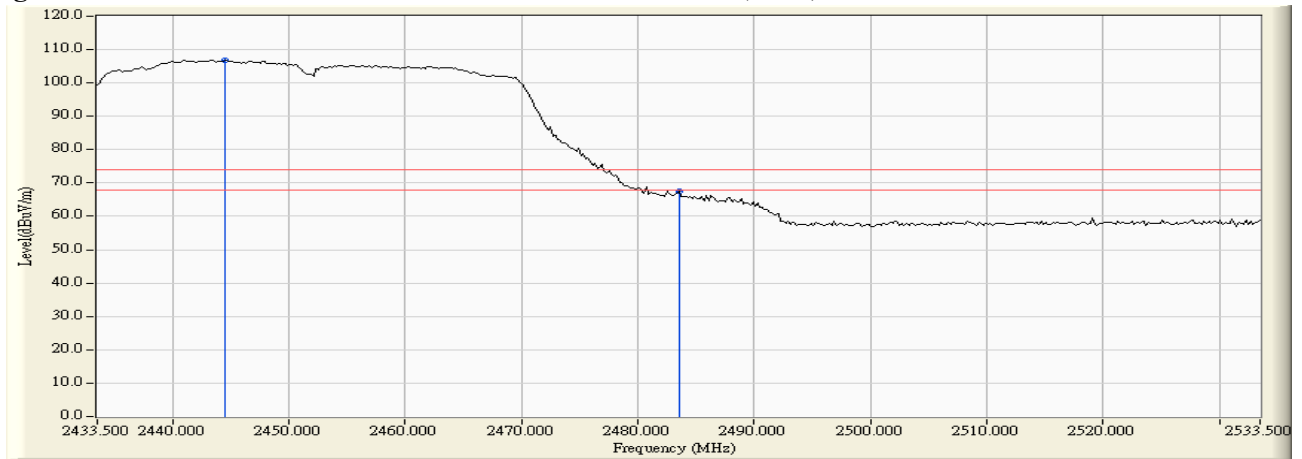

**Figure Channel 09: Horizontal (Average)**

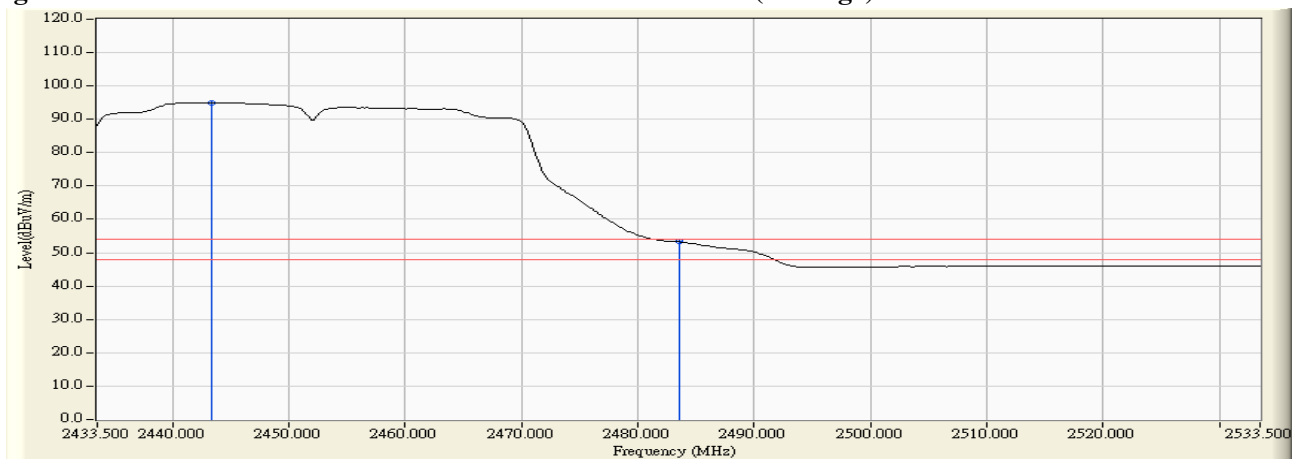

Note:

1. All readings above 1GHz are performed with peak and/or average measurements as necessary.
2. Peak measurements: RBW = 1MHz, VBW = 3 MHz, Sweep: Auto.
3. Average measurements: RBW = 1MHz, VBW = 10 Hz, Sweep: Auto.
4. “ \* ”, means this data is the worst emission level.
5. Measurement Level = Reading Level + Correct Factor.
6. The average measurement was not performed when the peak measured data under the limit of average detection.

Product : Intel® Dual Band Wireless-AC 8260  
 Test Item : Band Edge  
 Test Site : No.3 OATS  
 Test Mode : Mode 1 SISO A: Transmit - 802.11n-40BW\_15Mbps(2.4G Band)

**RF Radiated Measurement (Vertical):**

Channel No.	Frequency (MHz)	Correct Factor (dB)	Reading Level (dBuV)	Emission Level (dBuV/m)	Peak Limit (dBuV/m)	Average Limit (dBuV/m)	Result
09 (Peak)	2444.300	32.395	70.811	103.206	--	--	Pass
09 (Peak)	2483.500	32.586	30.783	63.368	74.00	54.00	Pass
09 (Average)	2445.500	32.402	58.830	91.231	--	--	Pass
09 (Average)	2483.500	32.586	17.271	49.856	74.00	54.00	Pass

**Figure Channel 09: Vertical (Peak)**

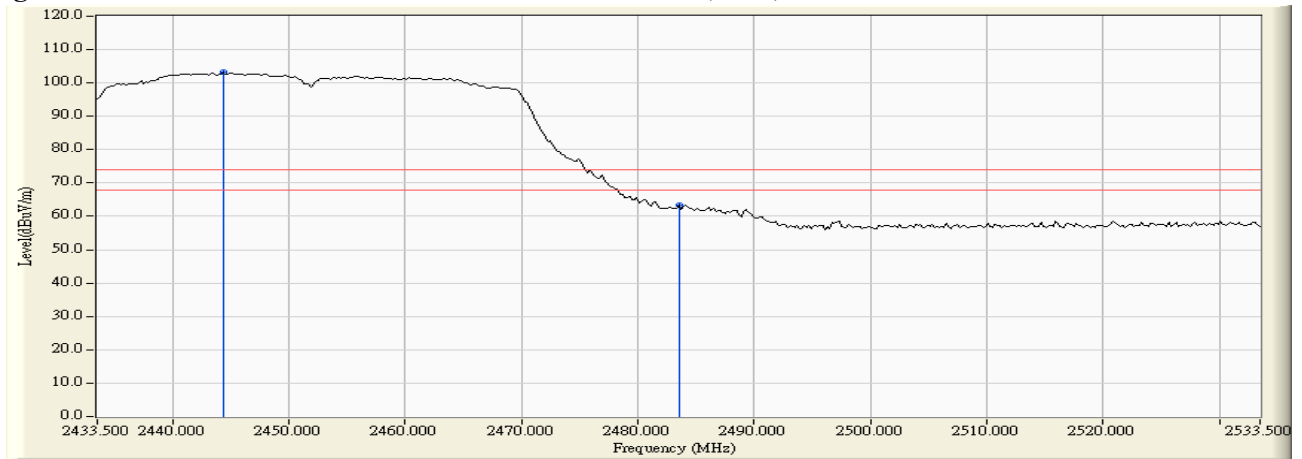

**Figure Channel 09: Vertical (Average)**

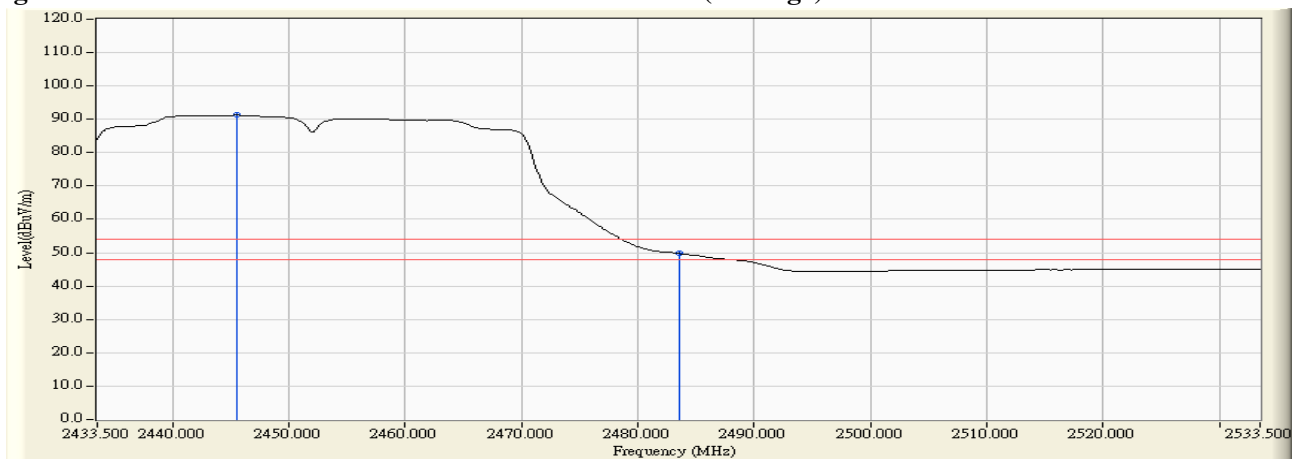

Note:

1. All readings above 1GHz are performed with peak and/or average measurements as necessary.
2. Peak measurements: RBW = 1MHz, VBW = 3 MHz, Sweep: Auto.
3. Average measurements: RBW = 1MHz, VBW = 10 Hz, Sweep: Auto.
4. “ \* ”, means this data is the worst emission level.
5. Measurement Level = Reading Level + Correct Factor.
6. The average measurement was not performed when the peak measured data under the limit of average detection.

Product : Intel® Dual Band Wireless-AC 8260  
 Test Item : Band Edge  
 Test Site : No.3 OATS  
 Test Mode : Mode 1 SISO A: Transmit - 802.11n-40BW\_15Mbps(2.4G Band)

**RF Radiated Measurement (Horizontal):**

Channel No.	Frequency (MHz)	Correct Factor (dB)	Reading Level (dBuV)	Emission Level (dBuV/m)	Peak Limit (dBuV/m)	Average Limit (dBuV/m)	Result
10 (Peak)	2444.500	33.848	73.089	106.937	--	--	Pass
10 (Peak)	2483.500	33.951	33.734	67.684	74.00	54.00	Pass
10 (Average)	2443.300	33.845	61.143	94.988	--	--	Pass
10 (Average)	2483.500	33.951	19.314	53.264	74.00	54.00	Pass

**Figure Channel 10: Horizontal (Peak)**

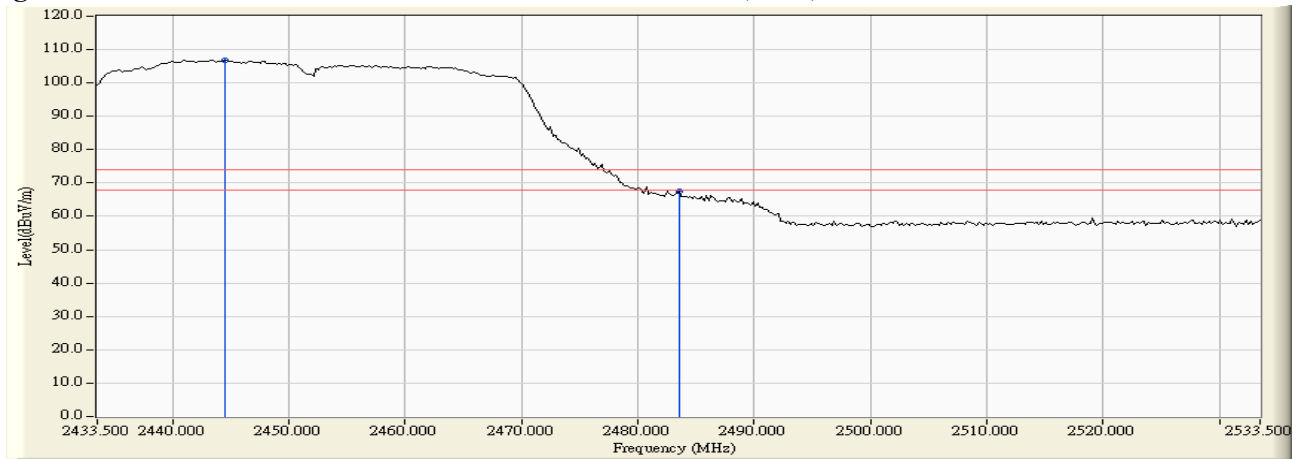

**Figure Channel 10: Horizontal (Average)**

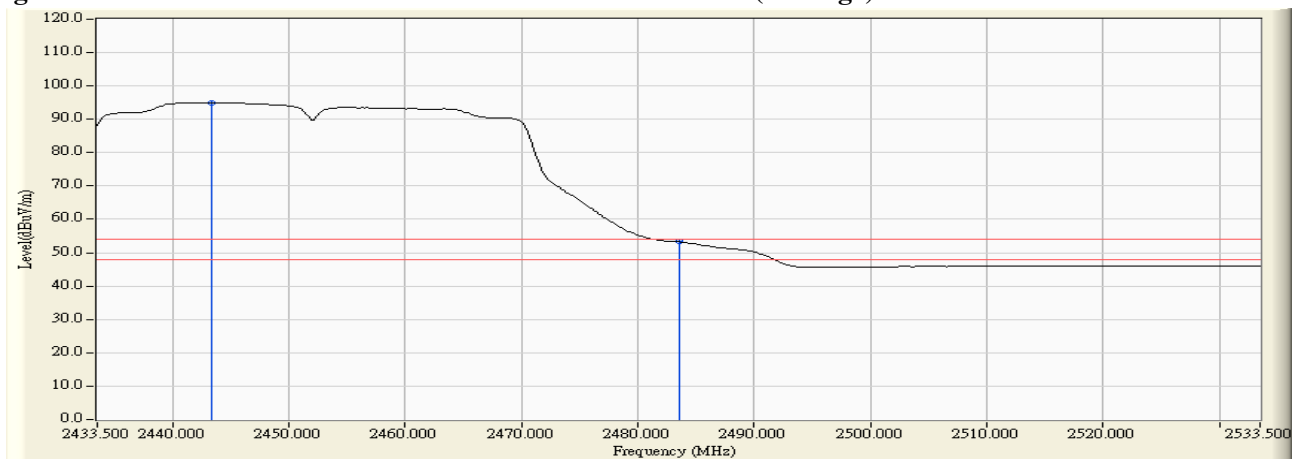

Note:

1. All readings above 1GHz are performed with peak and/or average measurements as necessary.
2. Peak measurements: RBW = 1MHz, VBW = 3 MHz, Sweep: Auto.
3. Average measurements: RBW = 1MHz, VBW = 10 Hz, Sweep: Auto.
4. “ \* ”, means this data is the worst emission level.
5. Measurement Level = Reading Level + Correct Factor.
6. The average measurement was not performed when the peak measured data under the limit of average detection.

Product : Intel® Dual Band Wireless-AC 8260  
 Test Item : Band Edge  
 Test Site : No.3 OATS  
 Test Mode : Mode 1 SISO A: Transmit - 802.11n-40BW\_15Mbps(2.4G Band)

**RF Radiated Measurement (Vertical):**

Channel No.	Frequency (MHz)	Correct Factor (dB)	Reading Level (dBuV)	Emission Level (dBuV/m)	Peak Limit (dBuV/m)	Average Limit (dBuV/m)	Result
10 (Peak)	2444.300	32.395	70.811	103.206	--	--	Pass
10 (Peak)	2483.500	32.586	30.783	63.368	74.00	54.00	Pass
10 (Average)	2445.500	32.402	58.830	91.231	--	--	Pass
10 (Average)	2483.500	32.586	17.271	49.856	74.00	54.00	Pass

**Figure Channel 10: Vertical (Peak)**

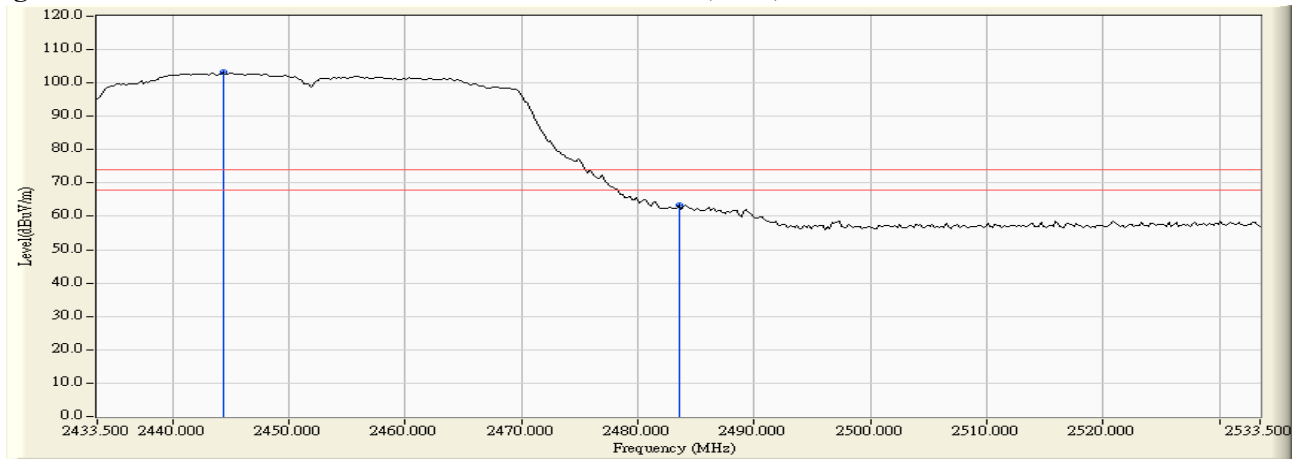

**Figure Channel 10: Vertical (Average)**

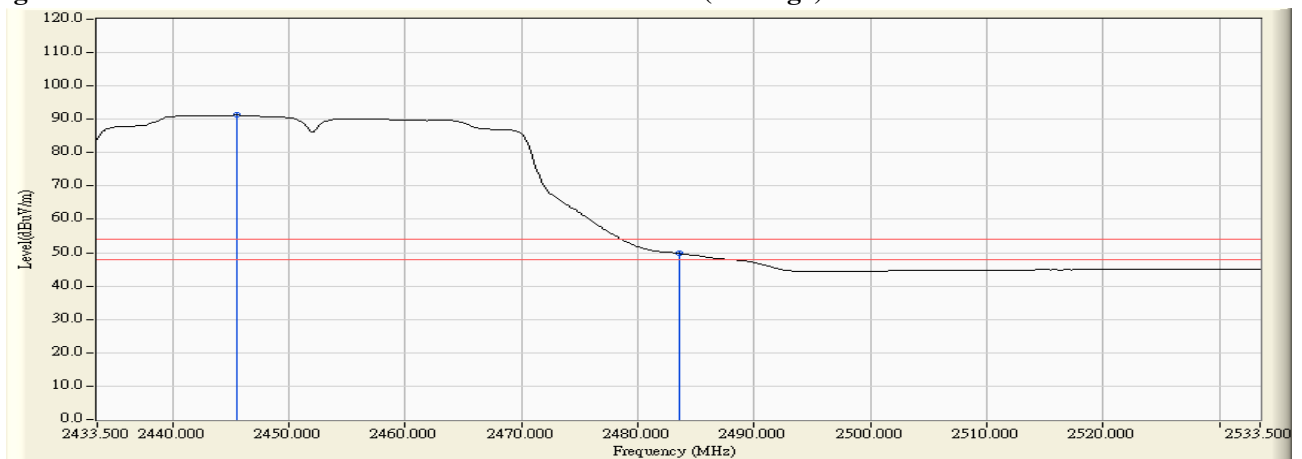

Note:

1. All readings above 1GHz are performed with peak and/or average measurements as necessary.
2. Peak measurements: RBW = 1MHz, VBW = 3 MHz, Sweep: Auto.
3. Average measurements: RBW = 1MHz, VBW = 10 Hz, Sweep: Auto.
4. “ \* ”, means this data is the worst emission level.
5. Measurement Level = Reading Level + Correct Factor.
6. The average measurement was not performed when the peak measured data under the limit of average detection.



Product : Intel® Dual Band Wireless-AC 8260  
 Test Item : Band Edge  
 Test Site : No.3 OATS  
 Test Mode : Mode 1 SISO A: Transmit - 802.11a 6Mbps

Test Frequency (MHz)	Measurement Level $\Delta$ (dB)	Limit $\Delta$ (dB)	Result
5745	33.86	>20	PASS

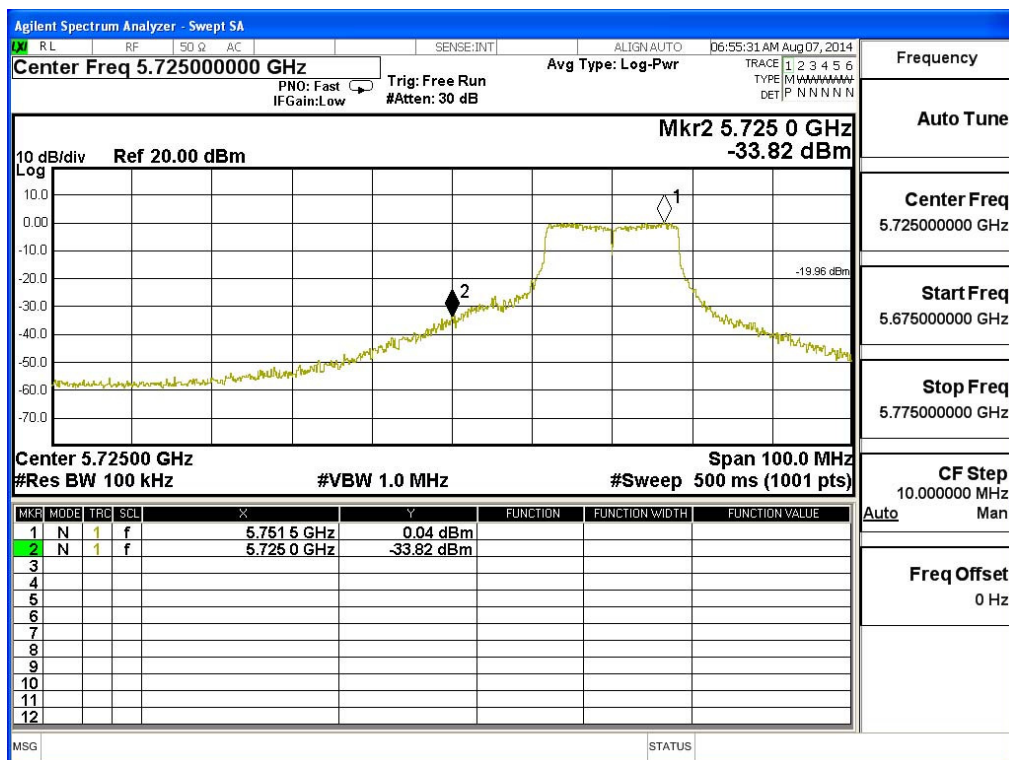

Product : Intel® Dual Band Wireless-AC 8260  
 Test Item : Band Edge  
 Test Site : No.3 OATS  
 Test Mode : Mode 1 SISO A: Transmit - 802.11a 6Mbps

Test Frequency (MHz)	Measurement Level $\Delta$ (dB)	Limit $\Delta$ (dB)	Result
5825	40.57	>20	PASS



Product : Intel® Dual Band Wireless-AC 8260  
 Test Item : Band Edge  
 Test Site : No.3 OATS  
 Test Mode : Mode 1 SISO A: Transmit - 802.11n-20BW\_7.2Mbps(5G Band)

Test Frequency (MHz)	Measurement Level $\Delta$ (dB)	Limit $\Delta$ (dB)	Result
5745	33.42	>20	PASS

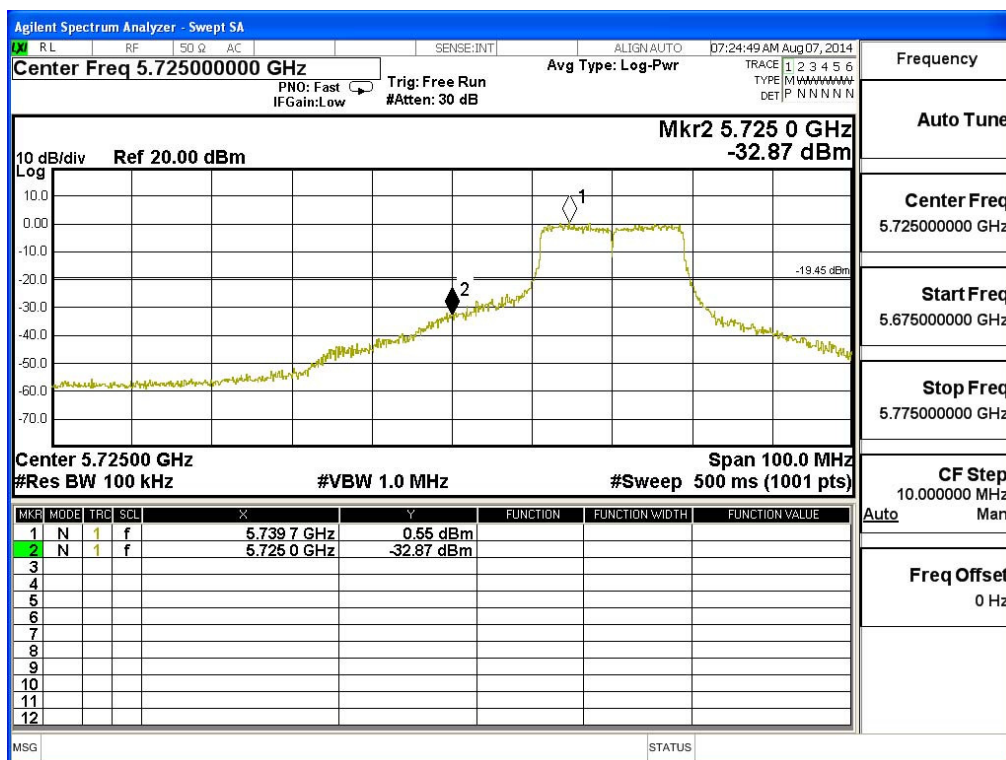

Product : Intel® Dual Band Wireless-AC 8260  
 Test Item : Band Edge  
 Test Site : No.3 OATS  
 Test Mode : Mode 1 SISO A: Transmit - 802.11n-20BW\_7.2Mbps(5G Band)

Test Frequency (MHz)	Measurement Level $\Delta$ (dB)	Limit $\Delta$ (dB)	Result
5825	40.63	>20	PASS



Product : Intel® Dual Band Wireless-AC 8260  
 Test Item : Band Edge  
 Test Site : No.3 OATS  
 Test Mode : Mode 1 SISO A: Transmit - 802.11n-40BW\_15Mbps(5G Band)

Test Frequency (MHz)	Measurement Level $\Delta$ (dB)	Limit $\Delta$ (dB)	Result
5755	28.78	>20	PASS



Product : Intel® Dual Band Wireless-AC 8260  
 Test Item : Band Edge  
 Test Site : No.3 OATS  
 Test Mode : Mode 1 SISO A: Transmit - 802.11n-40BW\_15Mbps(5G Band)

Test Frequency (MHz)	Measurement Level $\Delta$ (dB)	Limit $\Delta$ (dB)	Result
5795	51.02	>20	PASS

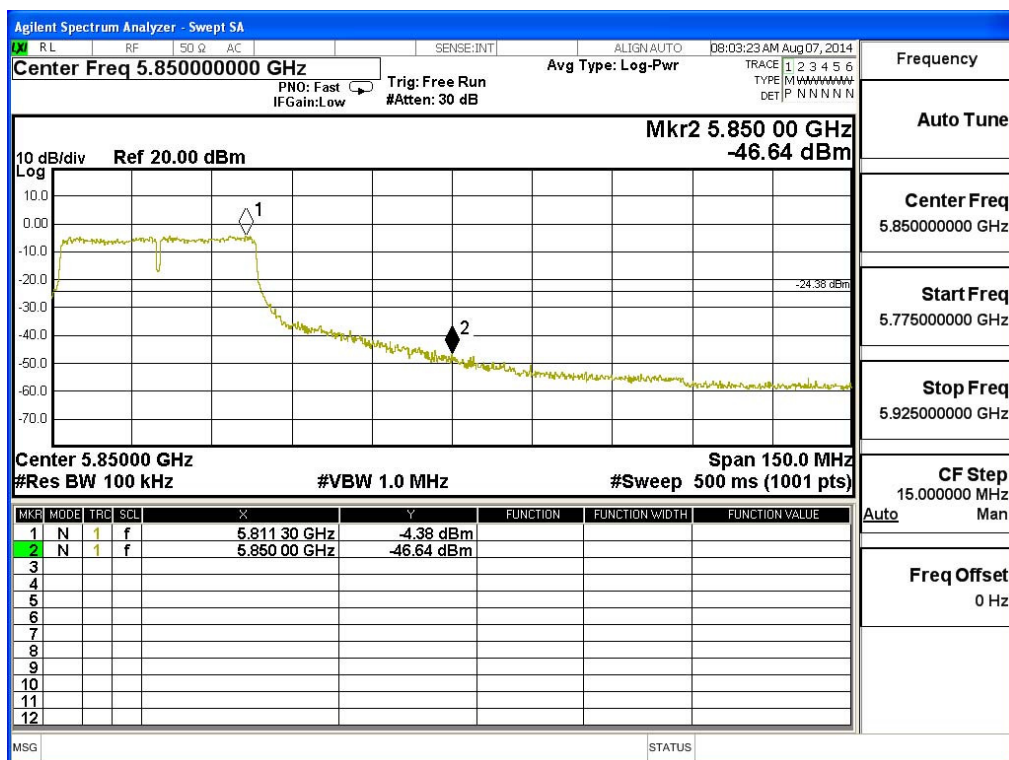

Product : Intel® Dual Band Wireless-AC 8260  
 Test Item : Band Edge  
 Test Site : No.3 OATS  
 Test Mode : Mode 1 SISO A: Transmit - 802.11ac-80BW\_32.5Mbps(5G Band)

Test Frequency (MHz)	Measurement Level $\Delta$ (dB)	Limit $\Delta$ (dB)	Result
5775	33.983	>30	PASS

