

# FCC Test Report

Product Name	Intel® Dual Band Wireless-AC 8260
Model No	8260NGW
FCC ID.	PD98260NG, PD98260NGU

\*FCC ID: PD98260NG (for OEM factory install)

\*FCC ID: PD98260NGU (for User Installation w/bios lock feature.)

Applicant	Intel Mobile Communications
Address	100 Center Point Circle, Suite 200 Columbia, South Carolina 29210 USA

Date of Receipt	Mar. 30, 2015
Issue Date	May 13, 2015
Report No.	1540055R-RFUSP01V00
Report Version	V1.0



The test results relate only to the samples tested.

The test results shown in the test report are traceable to the national/international standard through the calibration report of the equipment and evaluated measurement uncertainty herein.

This report must not be used to claim product endorsement by TAF or any agency of the government.

The test report shall not be reproduced without the written approval of Quietek Corporation.

# Test Report

Issue Date: May 13, 2015

Report No.: 1540055R-RFUSP01V00



Product Name	Intel® Dual Band Wireless-AC 8260
Applicant	Intel Mobile Communications
Address	100 Center Point Circle, Suite 200 Columbia, South Carolina 29210 USA
Manufacturer	Intel Mobile Communications
Model No.	8260NGW
EUT Rated Voltage	DC 3.3V (via Mini-PCI Express slot)
EUT Test Voltage	AC 120V/60Hz
Trade Name	Intel
Applicable Standard	FCC CFR Title 47 Part 15 Subpart C: 2013 ANSI C63.4: 2009, ANSI C63.10: 2009 KDB 558074 D01 DTS Meas Guidance v03r02
Test Result	Complied

Documented By : Jinn Chen  
 ( Senior Adm. Specialist / Jinn Chen )

Tested By : Alan Chen  
 ( Engineer / Alan Chen )

Approved By : [Signature]  
 ( Director / Vincent Lin )

## TABLE OF CONTENTS

Description	Page
<b>1. GENERAL INFORMATION .....</b>	<b>5</b>
1.1. EUT Description.....	5
1.2. Operational Description .....	8
1.3. Tested System Details.....	9
1.4. Configuration of Tested System .....	9
1.5. EUT Exercise Software .....	9
1.6. Test Facility .....	10
<b>2. Conducted Emission.....</b>	<b>11</b>
2.1. Test Equipment.....	11
2.2. Test Setup .....	11
2.3. Limits .....	12
2.4. Test Procedure .....	12
2.5. Uncertainty .....	12
2.6. Test Result of Conducted Emission.....	13
<b>3. Peak Power Output .....</b>	<b>29</b>
3.1. Test Equipment.....	29
3.2. Test Setup .....	29
3.3. Limits .....	29
3.4. Test Procedure .....	30
3.5. Uncertainty .....	30
3.6. Test Result of Peak Power Output.....	31
<b>4. Radiated Emission.....</b>	<b>65</b>
4.1. Test Equipment.....	65
4.2. Test Setup .....	66
4.3. Limits .....	67
4.4. Test Procedure .....	68
4.5. Uncertainty .....	68
4.6. Test Result of Radiated Emission.....	69
<b>5. RF antenna conducted test.....</b>	<b>173</b>
5.1. Test Equipment.....	173
5.2. Test Setup .....	173
5.3. Limits .....	173
5.4. Test Procedure .....	174
5.5. Uncertainty .....	174
5.6. Test Result of RF antenna conducted test.....	175
<b>6. Band Edge .....</b>	<b>249</b>
6.1. Test Equipment.....	249
6.2. Test Setup .....	250
6.3. Limits .....	250
6.4. Test Procedure .....	251
6.5. Uncertainty .....	251
6.6. Test Result of Band Edge .....	252

---

<b>7.</b>	<b>Occupied Bandwidth .....</b>	<b>518</b>
7.1.	Test Equipment .....	518
7.2.	Test Setup .....	518
7.3.	Limits .....	518
7.4.	Test Procedure .....	518
7.5.	Uncertainty .....	518
7.6.	Test Result of Occupied Bandwidth .....	519
<b>8.</b>	<b>Power Density .....</b>	<b>597</b>
8.1.	Test Equipment .....	597
8.2.	Test Setup .....	597
8.3.	Limits .....	597
8.4.	Test Procedure .....	597
8.5.	Uncertainty .....	597
8.6.	Test Result of Power Density .....	598
<b>9.</b>	<b>EMI Reduction Method During Compliance Testing .....</b>	<b>676</b>

Attachment 1: EUT Test Photographs

Attachment 2: EUT Detailed Photographs

## 1. GENERAL INFORMATION

### 1.1. EUT Description

Product Name	Intel® Dual Band Wireless-AC 8260
Trade Name	Intel
Model No.	8260NGW
FCC ID.	PD98260NG, PD98260NGU
Frequency Range	802.11b/g/n-20MHz:2412-2467MHz,802.11n-40MHz:2422-2457MHz 802.11a/n-20MHz:5745-5825MHz ,802.11n-40MHz:5755-5795MHz 802.11ac-80MHz: 5775MHz,
Number of Channels	802.11b/g/n-20MHz: 12, n-40MHz: 8 802.11a/n-20MHz: 5, n-40MHz: 2 802.11ac-80MHz: 1
Data Speed	802.11b: 1-11Mbps, 802.11a/g: 6-54Mbps, 802.11n: up to 300Mbps 802.11ac-80MHz: up to 866.7MHz
Channel separation	802.11b/g/n-20MHz: 5 MHz, 802.11a/n-20MHz: 20MHz 802.11n-40MHz: 40MHz, 802.11ac-80MHz: 80MHz
Type of Modulation	802.11b:DSSS, DBPSK, DQPSK, CCK 802.11a/g/n/ac: OFDM, BPSK, QPSK, 16QAM, 64QAM, 256QAM
Antenna Type	PIFA Antenna
Antenna Gain	Refer to the table “Antenna List”
Channel Control	Auto

#### Antenna List

No.	Manufacturer	Part No.	Antenna Type	Peak Gain
1	SkyCross	N/A (Main) N/A (Aux)	PIFA Antenna	3.24 dBi in 2.4GHz 4.97 dBi in 5.725~5.850GHz

Note: The antenna of EUT is conform to FCC 15.203

802.11b/g/n-20MHz Center Frequency of Each Channel:

Channel	Frequency	Channel	Frequency	Channel	Frequency	Channel	Frequency
Channel 01:	2412 MHz	Channel 02:	2417 MHz	Channel 03:	2422 MHz	Channel 04:	2427 MHz
Channel 05:	2432 MHz	Channel 06:	2437 MHz	Channel 07:	2442 MHz	Channel 08:	2447 MHz
Channel 09:	2452 MHz	Channel 10:	2457 MHz	Channel 11:	2462 MHz	Channel 12:	2467 MHz

802.11a/n-20MHz Center Working Frequency of Each Channel:

Channel	Frequency	Channel	Frequency	Channel	Frequency	Channel	Frequency
Channel 149:	5745 MHz	Channel 153:	5765 MHz	Channel 157:	5785 MHz	Channel 161:	5805 MHz
Channel 165:	5825 MHz						

802.11n-40MHz (2.4G Band) Center Working Frequency of Each Channel:

Channel	Frequency	Channel	Frequency	Channel	Frequency	Channel	Frequency
Channel 3:	2422 MHz	Channel 4:	2427 MHz	Channel 5:	2432 MHz	Channel 6:	2437 MHz
Channel 7:	2442 MHz	Channel 8:	2447 MHz	Channel 9:	2452 MHz	Channel 10:	2457 MHz

802.11n-40MHz (5G Band) Center Working Frequency of Each Channel:

Channel	Frequency	Channel	Frequency
Channel 151:	5755 MHz	Channel 159:	5795 MHz

802.11ac-80MHz Center Working Frequency of Each Channel:

Channel	Frequency
Channel 155:	5775 MHz

**Duty Cycle**

Formula:

$$\text{Duty cycle} = \text{Ton} / (\text{Ton} + \text{Toff})$$

$$\text{Duty Factor} = 10 \text{ Log} (1/\text{Duty Cycle})$$

Results:

2.4GHz band	Duty Cycle	Duty Factor (dB)	5GHz band	Duty Cycle	Duty Factor (dB)
802.11b	0.99	0.05	802.11a	0.98	0.08
802.11g	0.98	0.08	802.11n-20	0.98	0.09
802.11n-20	0.98	0.07	802.11n-40	0.97	0.15
802.11n-40	0.94	0.27	802.11ac-80	0.93	0.31

Note:

1. This device is an Intel® Dual Band Wireless-AC 8260 with a built-in 2.4GHz and 5GHz WLAN transceiver.
2. Regarding to the operation frequency, the lowest, middle and highest frequency are selected to perform the test.
3. These tests are conducted on a sample for the purpose of demonstrating compliance of 802.11a/b/g/n/ac transmitter with Part 15 Subpart C Paragraph 15.247 of spread spectrum devices.

Test Mode:	Mode 1 SISO A: Transmit (802.11b 1Mbps)
	Mode 1 SISO A: Transmit (802.11g 6Mbps)
	Mode 1 SISO A: Transmit - 802.11a 6Mbps
	Mode 1 SISO A: Transmit - 802.11n-20BW_7.2Mbps(2.4G Band)
	Mode 1 SISO A: Transmit - 802.11n-40BW_15Mbps(2.4G Band)
	Mode 1 SISO A: Transmit - 802.11n-20BW_7.2Mbps(5G Band)
	Mode 1 SISO A: Transmit - 802.11n-40BW_15Mbps(5G Band)
	Mode 1 SISO A: Transmit - 802.11ac-80BW_32.5Mbps(5G Band)
	Mode 2 SISO B: Transmit (802.11b 1Mbps)
	Mode 2 SISO B: Transmit (802.11g 6Mbps)
	Mode 2 SISO B: Transmit - 802.11a 6Mbps
	Mode 2 SISO B: Transmit - 802.11n-20BW_7.2Mbps(2.4G Band)
	Mode 2 SISO B: Transmit - 802.11n-40BW_15Mbps(2.4G Band)
	Mode 2 SISO B: Transmit - 802.11n-20BW_7.2Mbps(5G Band)
	Mode 2 SISO B: Transmit - 802.11n-40BW_15Mbps(5G Band)
	Mode 2 SISO B: Transmit - 802.11ac-80BW_32.5Mbps(5G Band)
	Mode 3 MIMO: Transmit - 802.11n-20BW_14.4Mbps(2.4G Band)
	Mode 3 MIMO: Transmit - 802.11n-40BW_30Mbps(2.4G Band)
	Mode 3 MIMO: Transmit - 802.11n-20BW_14.4Mbps(5G Band)
	Mode 3 MIMO: Transmit - 802.11n-40BW_30Mbps(5G Band)
	Mode 3 MIMO: Transmit - 802.11ac-80BW_65Mbps(5G Band)
	Mode 4 Beamforming: Transmit - 802.11n-20BW_14.4Mbps(2.4G Band)
	Mode 4 Beamforming: Transmit - 802.11n-40BW_30Mbps(2.4G Band)
	Mode 4 Beamforming: Transmit - 802.11n-20BW_14.4Mbps(5G Band)
	Mode 4 Beamforming: Transmit - 802.11n-40BW_30Mbps(5G Band)
	Mode 4 Beamforming: Transmit - 802.11ac-80BW_65Mbps(5G Band)

### 1.3. Tested System Details

The types for all equipment, plus descriptions of all cables used in the tested system (including inserted cards) are:

	Product	Manufacturer	Model No.	Serial No.	Power Cord
1	Notebook PC	DELL	N/A	N/A	Non-Shielded, 1.8m
2	Test Fixture	Intel	N/A	N/A	N/A

Signal Cable Type	Signal cable Description
A	Test Fixture Cable
	Non-Shielded, 1.0m

### 1.4. Configuration of Tested System

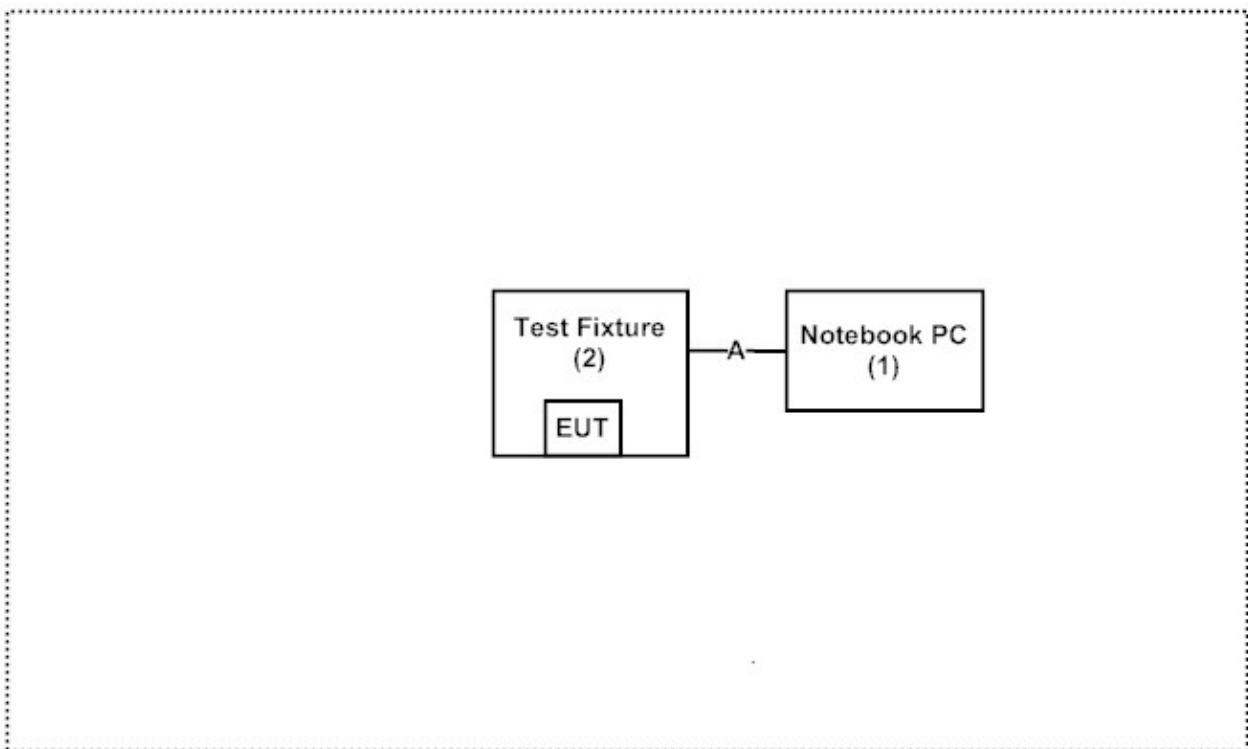

### 1.5. EUT Exercise Software

- (1) Setup the EUT and Peripherals as shown on 1.4
- (2) Execute software “DRTU (Ver 1.8.1-01253)” on the Notebook PC.
- (3) Configure the test mode, the test channel, and the data rate.
- (4) Press “OK” to start the continuous Transmit.
- (5) Verify that the EUT works properly.



**1.6. Test Facility**

Ambient conditions in the laboratory:

Items	Required (IEC 68-1)	Actual
Temperature (°C)	15-35	20-35
Humidity (%RH)	25-75	50-65
Barometric pressure (mbar)	860-1060	950-1000

The related certificate for our laboratories about the test site and management system can be downloaded from QuieTek Corporation's Web Site : <http://www.quietek.com/chinese/about/certificates.aspx?bval=5>  
 The address and introduction of QuieTek Corporation's laboratories can be founded in our Web site : <http://www.quietek.com/>

Site Description: File on  
 Federal Communications Commission  
 FCC Engineering Laboratory  
 7435 Oakland Mills Road  
 Columbia, MD 21046  
 Registration Number: 92195

Site Name: Quietek Corporation  
 Site Address: No.5-22, Ruishukeng,  
 Linkou Dist. New Taipei City 24451,  
 Taiwan, R.O.C.  
 TEL: 886-2-8601-3788 / FAX : 886-2-8601-3789  
 E-Mail : [service@quietek.com](mailto:service@quietek.com)

FCC Accreditation Number: TW1014

## 2. Conducted Emission

### 2.1. Test Equipment

	Equipment	Manufacturer	Model No. / Serial No.	Last Cal.	Remark
X	Test Receiver	R & S	ESCS 30 / 825442/018	Sep., 2014	
X	Artificial Mains Network	R & S	ENV4200 / 848411/10	Feb., 2015	Peripherals
X	LISN	R & S	ESH3-Z5 / 825562/002	Feb., 2015	EUT
	DC LISN	Schwarzbeck	8226 / 176	Mar., 2015	EUT
X	Pulse Limiter	R & S	ESH3-Z2 / 357.8810.52	Feb., 2015	
	No.1 Shielded Room				

Note:

1. All equipments are calibrated every one year.
2. The test instruments marked by "X" are used to measure the final test results.

### 2.2. Test Setup

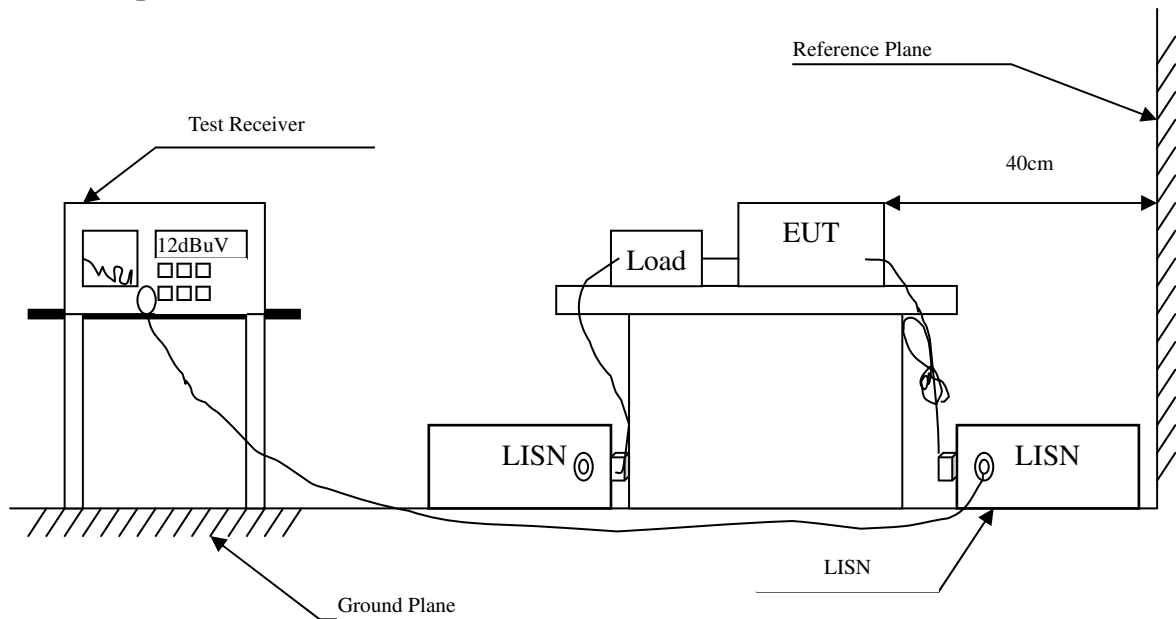

**2.3. Limits**

<b>FCC Part 15 Subpart C Paragraph 15.207 (dBuV) Limit</b>		
Frequency MHz	Limits	
	QP	AVG
0.15 - 0.50	66-56	56-46
0.50-5.0	56	46
5.0 - 30	60	50

**2.4. Test Procedure**

The EUT and simulators are connected to the main power through a line impedance stabilization network (L.I.S.N.). This provides a 50 ohm /50uH coupling impedance for the measuring equipment. The peripheral devices are also connected to the main power through a LISN that provides a 50ohm /50uH coupling impedance with 50ohm termination. (Please refers to the block diagram of the test setup and photographs.)

Both sides of A.C. line are checked for maximum conducted interference. In order to find the maximum emission, the relative positions of equipment and all of the interface cables must be changed according to ANSI C63.4: 2009 on conducted measurement.

Conducted emissions were invested over the frequency range from 0.15MHz to 30MHz using a receiver bandwidth of 9kHz.

**2.5. Uncertainty**

± 2.26 dB

**2.6. Test Result of Conducted Emission**

Product : Intel® Dual Band Wireless-AC 8260  
 Test Item : Conducted Emission Test  
 Power Line : Line 1  
 Test Mode : Mode 1 SISO A: Transmit - 802.11n-40BW\_15Mbps(2.4G Band) (2437MHz)

Frequency MHz	Correct Factor dB	Reading Level dBuV	Measurement Level dBuV	Margin dB	Limit dBuV
<b>Line 1</b>					
<b>Quasi-Peak</b>					
0.150	9.671	35.850	45.521	-20.479	66.000
0.209	9.661	25.990	35.651	-28.663	64.314
0.552	9.680	32.450	42.130	-13.870	56.000
1.533	9.743	21.390	31.133	-24.867	56.000
2.263	9.781	22.110	31.891	-24.109	56.000
18.357	10.047	12.430	22.477	-37.523	60.000
<b>Average</b>					
0.150	9.671	24.130	33.801	-22.199	56.000
0.209	9.661	16.370	26.031	-28.283	54.314
0.552	9.680	29.700	39.380	-6.620	46.000
1.533	9.743	14.660	24.403	-21.597	46.000
2.263	9.781	14.080	23.861	-22.139	46.000
18.357	10.047	2.050	12.097	-37.903	50.000

Note:

1. All Reading Levels are Quasi-Peak and average value.
2. “” means the worst emission level.
3. Measurement Level = Reading Level + Correct Factor

Product : Intel® Dual Band Wireless-AC 8260  
 Test Item : Conducted Emission Test  
 Power Line : Line 2  
 Test Mode : Mode 1 SISO A: Transmit - 802.11n-40BW\_15Mbps(2.4G Band) (2437MHz)

Frequency MHz	Correct Factor dB	Reading Level dBuV	Measurement Level dBuV	Margin dB	Limit dBuV
<b>Line 2</b>					
<b>Quasi-Peak</b>					
0.150	9.671	35.040	44.711	-21.289	66.000
0.181	9.662	31.750	41.412	-23.702	65.114
0.552	9.680	31.500	41.180	-14.820	56.000
1.556	9.744	20.520	30.264	-25.736	56.000
2.326	9.783	23.200	32.983	-23.017	56.000
18.689	10.170	13.650	23.820	-36.180	60.000
<b>Average</b>					
0.150	9.671	21.610	31.281	-24.719	56.000
0.181	9.662	19.710	29.372	-25.742	55.114
0.552	9.680	27.950	37.630	-8.370	46.000
1.556	9.744	14.620	24.364	-21.636	46.000
2.326	9.783	14.970	24.753	-21.247	46.000
18.689	10.170	4.220	14.390	-35.610	50.000

Note:

1. All Reading Levels are Quasi-Peak and average value.
2. "█" means the worst emission level.
3. Measurement Level = Reading Level + Correct Factor

Product : Intel® Dual Band Wireless-AC 8260  
 Test Item : Conducted Emission Test  
 Power Line : Line 1  
 Test Mode : Mode 1 SISO A: Transmit - 802.11ac-80BW\_32.5Mbps(5G Band) (5775MHz)

Frequency MHz	Correct Factor dB	Reading Level dBuV	Measurement Level dBuV	Margin dB	Limit dBuV
<b>Line 1</b>					
<b>Quasi-Peak</b>					
0.150	9.671	35.830	45.501	-20.499	66.000
0.181	9.662	33.320	42.982	-22.132	65.114
0.552	9.680	32.270	41.950	-14.050	56.000
1.568	9.745	19.990	29.735	-26.265	56.000
2.310	9.782	22.140	31.922	-24.078	56.000
18.837	10.051	11.950	22.001	-37.999	60.000
<b>Average</b>					
0.150	9.671	24.230	33.901	-22.099	56.000
0.181	9.662	23.450	33.112	-22.002	55.114
0.552	9.680	28.250	37.930	-8.070	46.000
1.568	9.745	11.750	21.495	-24.505	46.000
2.310	9.782	14.500	24.282	-21.718	46.000
18.837	10.051	1.580	11.631	-38.369	50.000

Note:

1. All Reading Levels are Quasi-Peak and average value.
2. “ “ means the worst emission level.
3. Measurement Level = Reading Level + Correct Factor

Product : Intel® Dual Band Wireless-AC 8260  
 Test Item : Conducted Emission Test  
 Power Line : Line 2  
 Test Mode : Mode 1 SISO A: Transmit - 802.11ac-80BW\_32.5Mbps(5G Band) (5775MHz)

Frequency MHz	Correct Factor dB	Reading Level dBuV	Measurement Level dBuV	Margin dB	Limit dBuV
<b>Line 2</b>					
<b>Quasi-Peak</b>					
0.158	9.668	28.700	38.368	-27.403	65.771
0.177	9.663	26.190	35.853	-29.376	65.229
0.552	9.680	31.200	40.880	-15.120	56.000
1.560	9.745	20.320	30.065	-25.935	56.000
2.322	9.783	23.020	32.803	-23.197	56.000
18.795	10.181	14.200	24.381	-35.619	60.000
<b>Average</b>					
0.158	9.668	14.840	24.508	-31.263	55.771
0.177	9.663	13.680	23.343	-31.886	55.229
0.552	9.680	26.820	36.500	-9.500	46.000
1.560	9.745	13.370	23.115	-22.885	46.000
2.322	9.783	14.580	24.363	-21.637	46.000
18.795	10.181	4.560	14.741	-35.259	50.000

Note:

1. All Reading Levels are Quasi-Peak and average value.
2. “ “ means the worst emission level.
3. Measurement Level = Reading Level + Correct Factor

Product : Intel® Dual Band Wireless-AC 8260  
 Test Item : Conducted Emission Test  
 Power Line : Line 1  
 Test Mode : Mode 2 SISO B: Transmit - 802.11n-40BW\_15Mbps(2.4G Band) (2437MHz)

Frequency MHz	Correct Factor dB	Reading Level dBuV	Measurement Level dBuV	Margin dB	Limit dBuV
<b>Line 1</b>					
<b>Quasi-Peak</b>					
0.150	9.671	36.490	46.161	-19.839	66.000
0.177	9.663	29.480	39.143	-26.086	65.229
0.240	9.663	26.150	35.813	-27.616	63.429
0.552	9.680	30.210	39.890	-16.110	56.000
2.080	9.773	18.240	28.013	-27.987	56.000
18.310	10.046	11.550	21.596	-38.404	60.000
<b>Average</b>					
0.150	9.671	20.430	30.101	-25.899	56.000
0.177	9.663	17.290	26.953	-28.276	55.229
0.240	9.663	16.470	26.133	-27.296	53.429
0.552	9.680	20.470	30.150	-15.850	46.000
2.080	9.773	11.660	21.433	-24.567	46.000
18.310	10.046	4.070	14.116	-35.884	50.000

Note:

1. All Reading Levels are Quasi-Peak and average value.
2. “ “ means the worst emission level.
3. Measurement Level = Reading Level + Correct Factor



Product : Intel® Dual Band Wireless-AC 8260  
 Test Item : Conducted Emission Test  
 Power Line : Line 2  
 Test Mode : Mode 2 SISO B: Transmit - 802.11n-40BW\_15Mbps(2.4G Band) (2437MHz)

Frequency MHz	Correct Factor dB	Reading Level dBuV	Measurement Level dBuV	Margin dB	Limit dBuV
<b>Line 2</b>					
<b>Quasi-Peak</b>					
0.154	9.670	35.720	45.390	-20.496	65.886
0.185	9.661	30.840	40.501	-24.499	65.000
0.212	9.661	28.870	38.531	-25.698	64.229
0.548	9.679	30.230	39.909	-16.091	56.000
2.349	9.783	21.160	30.943	-25.057	56.000
19.509	10.187	10.970	21.157	-38.843	60.000
<b>Average</b>					
0.154	9.670	28.800	38.470	-17.416	55.886
0.185	9.661	24.140	33.801	-21.199	55.000
0.212	9.661	17.140	26.801	-27.428	54.229
0.548	9.679	27.490	37.169	-8.831	46.000
2.349	9.783	16.170	25.953	-20.047	46.000
19.509	10.187	6.030	16.217	-33.783	50.000

Note:

1. All Reading Levels are Quasi-Peak and average value.
2. "■" means the worst emission level.
3. Measurement Level = Reading Level + Correct Factor

Product : Intel® Dual Band Wireless-AC 8260  
 Test Item : Conducted Emission Test  
 Power Line : Line 1  
 Test Mode : Mode 2 SISO B: Transmit - 802.11ac-80BW\_32.5Mbps(5G Band) (5775MHz)

Frequency MHz	Correct Factor dB	Reading Level dBuV	Measurement Level dBuV	Margin dB	Limit dBuV
<b>Line 1</b>					
<b>Quasi-Peak</b>					
0.154	9.670	36.190	45.860	-20.026	65.886
0.185	9.661	31.990	41.651	-23.349	65.000
0.548	9.679	31.210	40.889	-15.111	56.000
1.580	9.746	20.240	29.986	-26.014	56.000
2.345	9.783	20.750	30.533	-25.467	56.000
19.146	10.054	12.550	22.604	-37.396	60.000
<b>Average</b>					
0.154	9.670	20.540	30.210	-25.676	55.886
0.185	9.661	20.890	30.551	-24.449	55.000
0.548	9.679	30.930	40.609	-5.391	46.000
1.580	9.746	14.210	23.956	-22.044	46.000
2.345	9.783	13.080	22.863	-23.137	46.000
19.146	10.054	8.410	18.464	-31.536	50.000

Note:

1. All Reading Levels are Quasi-Peak and average value.
2. “ “ means the worst emission level.
3. Measurement Level = Reading Level + Correct Factor

Product : Intel® Dual Band Wireless-AC 8260  
 Test Item : Conducted Emission Test  
 Power Line : Line 2  
 Test Mode : Mode 2 SISO B: Transmit - 802.11ac-80BW\_32.5Mbps(5G Band) (5775MHz)

Frequency MHz	Correct Factor dB	Reading Level dBuV	Measurement Level dBuV	Margin dB	Limit dBuV
<b>Line 2</b>					
<b>Quasi-Peak</b>					
0.150	9.671	36.150	45.821	-20.179	66.000
0.177	9.663	28.450	38.113	-27.116	65.229
0.548	9.679	30.130	39.809	-16.191	56.000
0.572	9.681	28.610	38.291	-17.709	56.000
2.416	9.785	20.050	29.835	-26.165	56.000
19.197	10.184	12.770	22.954	-37.046	60.000
<b>Average</b>					
0.150	9.671	21.830	31.501	-24.499	56.000
0.177	9.663	10.360	20.023	-35.206	55.229
0.548	9.679	29.790	39.469	-6.531	46.000
0.572	9.681	25.420	35.101	-10.899	46.000
2.416	9.785	12.100	21.885	-24.115	46.000
19.197	10.184	5.780	15.964	-34.036	50.000

Note:

1. All Reading Levels are Quasi-Peak and average value.
2. “ “ means the worst emission level.
3. Measurement Level = Reading Level + Correct Factor

Product : Intel® Dual Band Wireless-AC 8260  
 Test Item : Conducted Emission Test  
 Power Line : Line 1  
 Test Mode : Mode 3 MIMO: Transmit - 802.11n-40BW\_30Mbps(2.4G Band) (2437MHz)

Frequency MHz	Correct Factor dB	Reading Level dBuV	Measurement Level dBuV	Margin dB	Limit dBuV
<b>Line 1</b>					
<b>Quasi-Peak</b>					
0.150	9.671	36.490	46.161	-19.839	66.000
0.177	9.663	29.480	39.143	-26.086	65.229
0.240	9.663	26.150	35.813	-27.616	63.429
0.552	9.680	30.210	39.890	-16.110	56.000
2.080	9.773	18.240	28.013	-27.987	56.000
18.310	10.046	11.550	21.596	-38.404	60.000
<b>Average</b>					
0.150	9.671	20.430	30.101	-25.899	56.000
0.177	9.663	17.290	26.953	-28.276	55.229
0.240	9.663	16.470	26.133	-27.296	53.429
0.552	9.680	20.470	30.150	-15.850	46.000
2.080	9.773	11.660	21.433	-24.567	46.000
18.310	10.046	4.070	14.116	-35.884	50.000

Note:

1. All Reading Levels are Quasi-Peak and average value.
2. "■" means the worst emission level.
3. Measurement Level = Reading Level + Correct Factor

Product : Intel® Dual Band Wireless-AC 8260  
 Test Item : Conducted Emission Test  
 Power Line : Line 2  
 Test Mode : Mode 3 MIMO: Transmit - 802.11n-40BW\_30Mbps(2.4G Band) (2437MHz)

Frequency MHz	Correct Factor dB	Reading Level dBuV	Measurement Level dBuV	Margin dB	Limit dBuV
<b>Line 2</b>					
<b>Quasi-Peak</b>					
0.154	9.670	35.720	45.390	-20.496	65.886
0.185	9.661	30.840	40.501	-24.499	65.000
0.212	9.661	28.870	38.531	-25.698	64.229
0.548	9.679	30.230	39.909	-16.091	56.000
2.349	9.783	21.160	30.943	-25.057	56.000
19.509	10.187	10.970	21.157	-38.843	60.000
<b>Average</b>					
0.154	9.670	28.800	38.470	-17.416	55.886
0.185	9.661	24.140	33.801	-21.199	55.000
0.212	9.661	17.140	26.801	-27.428	54.229
0.548	9.679	27.490	37.169	-8.831	46.000
2.349	9.783	16.170	25.953	-20.047	46.000
19.509	10.187	6.030	16.217	-33.783	50.000

Note:

1. All Reading Levels are Quasi-Peak and average value.
2. "■" means the worst emission level.
3. Measurement Level = Reading Level + Correct Factor

Product : Intel® Dual Band Wireless-AC 8260  
 Test Item : Conducted Emission Test  
 Power Line : Line 1  
 Test Mode : Mode 3 MIMO: Transmit - 802.11ac-80BW\_65Mbps(5G Band) (5775MHz)

Frequency MHz	Correct Factor dB	Reading Level dBuV	Measurement Level dBuV	Margin dB	Limit dBuV
<b>Line 1</b>					
<b>Quasi-Peak</b>					
0.154	9.670	36.190	45.860	-20.026	65.886
0.185	9.661	31.990	41.651	-23.349	65.000
0.548	9.679	31.210	40.889	-15.111	56.000
1.580	9.746	20.240	29.986	-26.014	56.000
2.345	9.783	20.750	30.533	-25.467	56.000
19.146	10.054	12.550	22.604	-37.396	60.000
<b>Average</b>					
0.154	9.670	20.540	30.210	-25.676	55.886
0.185	9.661	20.890	30.551	-24.449	55.000
0.548	9.679	30.930	40.609	-5.391	46.000
1.580	9.746	14.210	23.956	-22.044	46.000
2.345	9.783	13.080	22.863	-23.137	46.000
19.146	10.054	8.410	18.464	-31.536	50.000

Note:

1. All Reading Levels are Quasi-Peak and average value.
2. “ “ means the worst emission level.
3. Measurement Level = Reading Level + Correct Factor

Product : Intel® Dual Band Wireless-AC 8260  
 Test Item : Conducted Emission Test  
 Power Line : Line 2  
 Test Mode : Mode 3 MIMO: Transmit - 802.11ac-80BW\_65Mbps(5G Band) (5775MHz)

Frequency MHz	Correct Factor dB	Reading Level dBuV	Measurement Level dBuV	Margin dB	Limit dBuV
<b>Line 2</b>					
<b>Quasi-Peak</b>					
0.150	9.671	36.150	45.821	-20.179	66.000
0.177	9.663	28.450	38.113	-27.116	65.229
0.548	9.679	30.130	39.809	-16.191	56.000
0.572	9.681	28.610	38.291	-17.709	56.000
2.416	9.785	20.050	29.835	-26.165	56.000
19.197	10.184	12.770	22.954	-37.046	60.000
<b>Average</b>					
0.150	9.671	21.830	31.501	-24.499	56.000
0.177	9.663	10.360	20.023	-35.206	55.229
0.548	9.679	29.790	39.469	-6.531	46.000
0.572	9.681	25.420	35.101	-10.899	46.000
2.416	9.785	12.100	21.885	-24.115	46.000
19.197	10.184	5.780	15.964	-34.036	50.000

Note:

1. All Reading Levels are Quasi-Peak and average value.
2. “ “ means the worst emission level.
3. Measurement Level = Reading Level + Correct Factor

Product : Intel® Dual Band Wireless-AC 8260  
 Test Item : Conducted Emission Test  
 Power Line : Line 1  
 Test Mode : Mode 4 Beamforming: Transmit - 802.11n-40BW\_30Mbps(2.4G Band) (2437MHz)

Frequency MHz	Correct Factor dB	Reading Level dBuV	Measurement Level dBuV	Margin dB	Limit dBuV
<b>Line 1</b>					
<b>Quasi-Peak</b>					
0.154	9.670	36.210	45.880	-20.006	65.886
0.177	9.663	32.760	42.423	-22.806	65.229
0.209	9.661	31.150	40.811	-23.503	64.314
0.568	9.680	30.720	40.400	-15.600	56.000
2.337	9.783	20.310	30.093	-25.907	56.000
19.283	10.055	11.900	21.955	-38.045	60.000
<b>Average</b>					
0.154	9.670	20.850	30.520	-25.366	55.886
0.177	9.663	23.550	33.213	-22.016	55.229
0.209	9.661	26.670	36.331	-17.983	54.314
0.568	9.680	27.770	37.450	-8.550	46.000
2.337	9.783	12.550	22.333	-23.667	46.000
19.283	10.055	3.320	13.375	-36.625	50.000

Note:

1. All Reading Levels are Quasi-Peak and average value.
2. "■" means the worst emission level.
3. Measurement Level = Reading Level + Correct Factor



Product : Intel® Dual Band Wireless-AC 8260  
 Test Item : Conducted Emission Test  
 Power Line : Line 2  
 Test Mode : Mode 4 Beamforming: Transmit - 802.11n-40BW\_30Mbps(2.4G Band) (2437MHz)

Frequency MHz	Correct Factor dB	Reading Level dBuV	Measurement Level dBuV	Margin dB	Limit dBuV
<b>Line 2</b>					
<b>Quasi-Peak</b>					
0.181	9.662	34.070	43.732	-21.382	65.114
0.212	9.661	29.750	39.411	-24.818	64.229
0.541	9.679	28.610	38.289	-17.711	56.000
0.568	9.680	29.650	39.330	-16.670	56.000
2.396	9.784	20.830	30.614	-25.386	56.000
18.365	10.167	9.370	19.537	-40.463	60.000
<b>Average</b>					
0.181	9.662	26.780	36.442	-18.672	55.114
0.212	9.661	13.320	22.981	-31.248	54.229
0.541	9.679	27.680	37.359	-8.641	46.000
0.568	9.680	24.210	33.890	-12.110	46.000
2.396	9.784	15.950	25.734	-20.266	46.000
18.365	10.167	1.370	11.537	-38.463	50.000

Note:

1. All Reading Levels are Quasi-Peak and average value.
2. "■" means the worst emission level.
3. Measurement Level = Reading Level + Correct Factor

Product : Intel® Dual Band Wireless-AC 8260  
 Test Item : Conducted Emission Test  
 Power Line : Line 1  
 Test Mode : Mode 4 Beamforming: Transmit - 802.11ac-80BW\_65Mbps(5G Band) (5775MHz)

Frequency MHz	Correct Factor dB	Reading Level dBuV	Measurement Level dBuV	Margin dB	Limit dBuV
<b>Line 1</b>					
<b>Quasi-Peak</b>					
0.177	9.663	32.140	41.803	-23.426	65.229
0.212	9.661	32.160	41.821	-22.408	64.229
0.545	9.679	30.890	40.569	-15.431	56.000
0.572	9.681	31.290	40.971	-15.029	56.000
2.334	9.783	21.050	30.833	-25.167	56.000
19.240	10.055	11.630	21.685	-38.315	60.000
<b>Average</b>					
0.177	9.663	26.890	36.553	-18.676	55.229
0.212	9.661	20.470	30.131	-24.098	54.229
0.545	9.679	29.790	39.469	-6.531	46.000
0.572	9.681	27.540	37.221	-8.779	46.000
2.334	9.783	10.520	20.303	-25.697	46.000
19.240	10.055	0.680	10.735	-39.265	50.000

Note:

1. All Reading Levels are Quasi-Peak and average value.
2. “ “ means the worst emission level.
3. Measurement Level = Reading Level + Correct Factor

Product : Intel® Dual Band Wireless-AC 8260  
 Test Item : Conducted Emission Test  
 Power Line : Line 2  
 Test Mode : Mode 4 Beamforming: Transmit - 802.11ac-80BW\_65Mbps(5G Band) (5775MHz)

Frequency MHz	Correct Factor dB	Reading Level dBuV	Measurement Level dBuV	Margin dB	Limit dBuV
<b>Line 2</b>					
<b>Quasi-Peak</b>					
0.212	9.661	30.170	39.831	-24.398	64.229
0.244	9.663	26.030	35.693	-27.621	63.314
0.302	9.666	20.060	29.726	-31.931	61.657
0.545	9.679	29.650	39.329	-16.671	56.000
2.357	9.783	21.240	31.023	-24.977	56.000
19.111	10.184	11.740	21.924	-38.076	60.000
<b>Average</b>					
0.212	9.661	14.080	23.741	-30.488	54.229
0.244	9.663	17.200	26.863	-26.451	53.314
0.302	9.666	1.060	10.726	-40.931	51.657
0.545	9.679	28.190	37.869	-8.131	46.000
2.357	9.783	15.730	25.513	-20.487	46.000
19.111	10.184	3.300	13.484	-36.516	50.000

Note:

1. All Reading Levels are Quasi-Peak and average value.
2. “ “ means the worst emission level.
3. Measurement Level = Reading Level + Correct Factor

### 3. Peak Power Output

#### 3.1. Test Equipment

	Equipment	Manufacturer	Model No./Serial No.	Last Cal.
X	Power Meter	Anritsu	ML2495A/6K00003357	May, 2015
X	Power Sensor	Anritsu	MA2411B/0738448	Jun., 2014
	Spectrum Analyzer	R&S	FSP40 / 100170	Jun., 2014
	Spectrum Analyzer	Agilent	E4407B / US39440758	Jun., 2014
X	Spectrum Analyzer	Agilent	N9010A / MY48030495	Apr., 2015

Note:

1. All equipments are calibrated with traceable calibrations. Each calibration is traceable to the national or international standards.
2. The test instruments marked with “X” are used to measure the final test results.

#### 3.2. Test Setup

##### Conduction Power Measurement (for $\leq 40$ MHz)

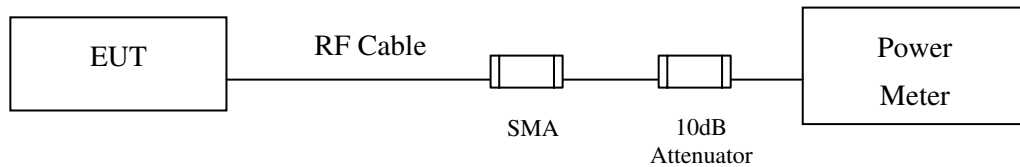

##### Conduction Power Measurement (for 80 MHz)

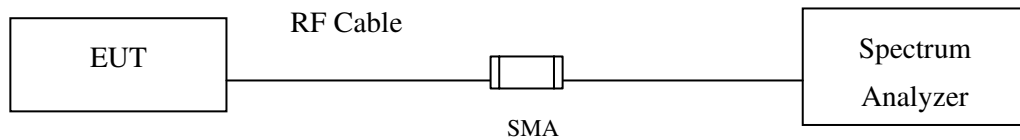

#### 3.3. Limits

The maximum peak power shall be less 1 Watt.

### 3.4. Test Procedure

The EUT was tested according to DTS test procedure of KDB 558074 for compliance to FCC 47CFR 15.247 requirements.

**BW  $\leq$  40MHz:** The maximum peak conducted output power using KDB 558074 D01 DTS Meas Guidance v03r02 section 9.1.2 PKPM1 Peak power meter method

Note: the power meter have a video bandwidth that is greater than or equal to the measurement bandwidth, (Anritsu/ MA2411B video bandwidth: 50MHz)

**BW=80MHz:** The maximum average conducted output power using KDB 558074 D01 DTS Meas Guidance v03r02 section 9.2.2.2 Method AVGSA-1, Measurement using a spectrum analyzer (SA) for 802.11ac. (Trace averaging with the EUT transmitting at full power throughout each sweep).

### 3.5. Uncertainty

Power sensor/meter method:  $\pm 0.517$  dB

Spectrum analyzer method:  $\pm 1.27$  dB

### 3.6. Test Result of Peak Power Output

Product : Intel® Dual Band Wireless-AC 8260  
 Test Item : Peak Power Output Data  
 Test Site : No.3 OATS  
 Test Mode : Mode 1 SISO A: Transmit (802.11b 1Mbps)

Channel No	Frequency (MHz)	Average Power For different Data Rate (Mbps)				Peak Power	Required Limit	Result
		1	2	5.5	11			
		Measurement Level (dBm)						
01	2412	18.77	--	--	--	20.84	<30dBm	Pass
02	2417	19.12	--	--	--	21.11	<30dBm	Pass
03	2422	21.01	--	--	--	22.79	<30dBm	Pass
06	2437	21.18	21.15	21.12	21.09	22.88	<30dBm	Pass
09	2452	21.14	--	--	--	22.77	<30dBm	Pass
10	2457	19.87	--	--	--	21.67	<30dBm	Pass
11	2462	20.12	--	--	--	21.84	<30dBm	Pass
12	2467	17.04	--	--	--	18.76	<30dBm	Pass

Note: Peak Power Output Value = Reading value on power meter + cable loss

Product : Intel® Dual Band Wireless-AC 8260  
 Test Item : Peak Power Output Data  
 Test Site : No.3 OATS  
 Test Mode : Mode 1 SISO A: Transmit (802.11g 6Mbps)

Channel No	Frequency (MHz)	Average Power For different Data Rate (Mbps)								Peak Power	Required Limit	Result
		6	9	12	18	24	36	48	54			
		Measurement Level (dBm)										
01	2412	18.58	--	--	--	--	--	--	--	22.97	<30dBm	Pass
02	2417	20.03	--	--	--	--	--	--	--	23.64	<30dBm	Pass
06	2437	21.28	21.21	21.14	21.07	21	20.93	20.86	20.79	24.01	<30dBm	Pass
10	2457	19.66	--	--	--	--	--	--	--	23.56	<30dBm	Pass
11	2462	17.68	--	--	--	--	--	--	--	22.44	<30dBm	Pass
12	2467	13.61	--	--	--	--	--	--	--	18.61	<30dBm	Pass

Note: Peak Power Output Value = Reading value on power meter + cable loss

Product : Intel® Dual Band Wireless-AC 8260  
 Test Item : Peak Power Output Data  
 Test Site : No.3 OATS  
 Test Mode : Mode 1 SISO A: Transmit - 802.11a 6Mbps

Channel No	Frequency (MHz)	Average Power For different Data Rate (Mbps)								Peak Power	Required Limit	Result
		6	9	12	18	24	36	48	54			
		Measurement Level (dBm)										
149	5745	21.60	--	--	--	--	--	--	--	24.01	<30dBm	Pass
157	5785	21.60	21.52	21.43	21.37	21.28	21.16	21.08	20.97	23.95	<30dBm	Pass
165	5825	21.57	--	--	--	--	--	--	--	23.91	<30dBm	Pass

Note: Peak Power Output Value = Reading value on power meter + cable loss



Product : Intel® Dual Band Wireless-AC 8260  
 Test Item : Peak Power Output Data  
 Test Site : No.3 OATS  
 Test Mode : Mode 1 SISO A: Transmit - 802.11n-20BW\_7.2Mbps(2.4G Band)

Channel No	Frequency (MHz)	Average Power For different Data Rate (Mbps)								Peak Power	Required Limit	Result
		HT0	HT1	HT2	HT3	HT4	HT5	HT6	HT7	HT0		
		Measurement Level (dBm)										
01	2412	17.89	--	--	--	--	--	--	--	22.56	<30dBm	Pass
02	2417	19.13	--	--	--	--	--	--	--	23.31	<30dBm	Pass
06	2437	21.17	21.11	21.05	20.99	20.93	20.87	20.81	20.75	23.96	<30dBm	Pass
10	2457	19.38	--	--	--	--	--	--	--	23.43	<30dBm	Pass
11	2462	17.07	--	--	--	--	--	--	--	21.98	<30dBm	Pass
12	2467	13.97	--	--	--	--	--	--	--	19.09	<30dBm	Pass

Note: Peak Power Output Value = Reading value on power meter + cable loss

Product : Intel® Dual Band Wireless-AC 8260  
 Test Item : Peak Power Output Data  
 Test Site : No.3 OATS  
 Test Mode : Mode 1 SISO A: Transmit - 802.11n-40BW\_15Mbps(2.4G Band)

Channel No	Frequency (MHz)	Average Power For different Data Rate (Mbps)								Peak Power	Required Limit	Result
		HT0	HT1	HT2	HT3	HT4	HT5	HT6	HT7	HT0		
		Measurement Level (dBm)										
03	2422	15.01	--	--	--	--	--	--	--	18.48	<30dBm	Pass
04	2427	16.88	--	--	--	--	--	--	--	20.34	<30dBm	Pass
06	2437	17.15	17.08	17.01	16.94	16.87	16.8	16.73	16.66	20.59	<30dBm	Pass
07	2442	15.91	--	--	--	--	--	--	--	19.61	<30dBm	Pass
08	2447	15.21	--	--	--	--	--	--	--	18.63	<30dBm	Pass
09	2452	15.28	--	--	--	--	--	--	--	18.78	<30dBm	Pass
10	2457	12.62	--	--	--	--	--	--	--	16.11	<30dBm	Pass

Note: Peak Power Output Value = Reading value on power meter + cable loss

Product : Intel® Dual Band Wireless-AC 8260  
 Test Item : Peak Power Output Data  
 Test Site : No.3 OATS  
 Test Mode : Mode 1 SISO A: Transmit - 802.11n-20BW\_7.2Mbps(5G Band)

Channel No	Frequency (MHz)	Average Power For different Data Rate (Mbps)									Peak Power	Required Limit	Result
		HT0	HT1	HT2	HT3	HT4	HT5	HT6	HT7	HT0			
		Measurement Level (dBm)											
149	5745	21.34	--	--	--	--	--	--	--	23.96	<30dBm	Pass	
157	5785	21.44	21.36	21.27	21.13	21.05	20.94	20.83	20.74	23.89	<30dBm	Pass	
165	5825	21.47	--	--	--	--	--	--	--	23.98	<30dBm	Pass	

Note: Peak Power Output Value =Reading value on power meter + cable loss

Product : Intel® Dual Band Wireless-AC 8260  
 Test Item : Peak Power Output Data  
 Test Site : No.3 OATS  
 Test Mode : Mode 1 SISO A: Transmit - 802.11n-40BW\_15Mbps(5G Band)

Channel No	Frequency (MHz)	Average Power									Peak Power	Required Limit	Result
		For different Data Rate (Mbps)											
		HT0	HT1	HT2	HT3	HT4	HT5	HT6	HT7	HT0			
Measurement Level (dBm)													
151	5755	21.51	21.46	21.37	21.24	21.16	21.05	20.94	20.84	23.80	<30dBm	Pass	
159	5795	21.61	--	--	--	--	--	--	--	23.84	<30dBm	Pass	

Note: Peak Power Output Value = Reading value on power meter + cable loss

Product : Intel® Dual Band Wireless-AC 8260  
 Test Item : Peak Power Output Data  
 Test Site : No.3 OATS  
 Test Mode : Mode 1 SISO A: Transmit - 802.11ac-80BW\_32.5Mbps(5G Band)

Channel No	Frequency (MHz)	Average Power										Required Limit	Result
		For different Data Rate (Mbps)											
		VTH0	VTH1	VTH2	VTH3	VTH4	VTH5	VTH6	VTH7	VTH8	VTH9		
Measurement Level (dBm)													
155	5775	21.08	21.04	20.93	20.84	20.77	20.64	20.58	20.48	20.35	20.25	<30dBm	Pass

Note: Peak Power Output Value = Reading value on power meter + cable loss

**Figure Channel 155:**

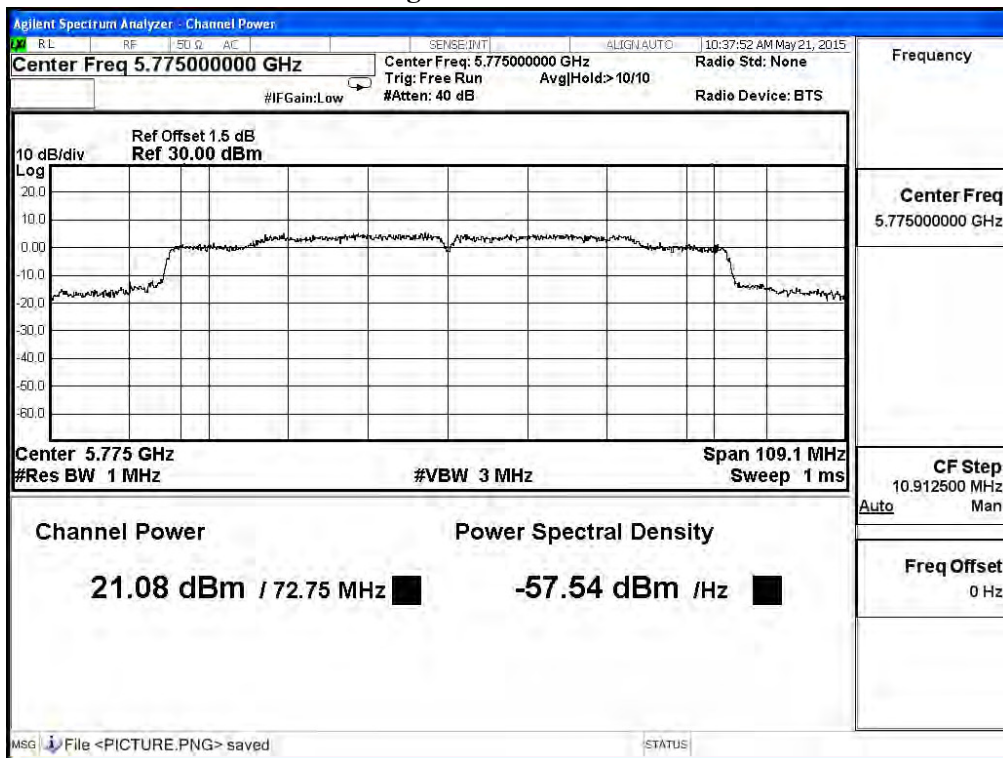

Product : Intel® Dual Band Wireless-AC 8260  
 Test Item : Peak Power Output Data  
 Test Site : No.3 OATS  
 Test Mode : Mode 2 SISO B: Transmit (802.11b 1Mbps)

Channel No	Frequency (MHz)	Average Power For different Data Rate (Mbps)				Peak Power	Required Limit	Result
		1	2	5.5	11	1		
		Measurement Level (dBm)						
01	2412	18.44	--	--	--	20.13	<30dBm	Pass
02	2417	20.72	--	--	--	22.34	<30dBm	Pass
06	2437	21.12	21.17	21.22	21.27	22.58	<30dBm	Pass
09	2452	21.23	--	--	--	22.78	<30dBm	Pass
10	2457	19.32	--	--	--	21.02	<30dBm	Pass
11	2462	19.30	--	--	--	21.01	<30dBm	Pass
12	2467	16.06	--	--	--	17.86	<30dBm	Pass

Note: Peak Power Output Value = Reading value on power meter + cable loss

Product : Intel® Dual Band Wireless-AC 8260  
 Test Item : Peak Power Output Data  
 Test Site : No.3 OATS  
 Test Mode : Mode 2 SISO B: Transmit (802.11g 6Mbps)

Channel No	Frequency (MHz)	Average Power For different Data Rate (Mbps)								Peak Power	Required Limit	Result
		6	9	12	18	24	36	48	54			
		Measurement Level (dBm)										
01	2412	18.50	--	--	--	--	--	--	--	22.60	<30dBm	Pass
06	2437	20.48	20.41	20.34	20.27	20.2	20.13	20.06	19.99	23.28	<30dBm	Pass
11	2462	17.99	--	--	--	--	--	--	--	22.35	<30dBm	Pass
12	2467	15.37	--	--	--	--	--	--	--	20.31	<30dBm	Pass

Note: Peak Power Output Value = Reading value on power meter + cable loss

Product : Intel® Dual Band Wireless-AC 8260  
 Test Item : Peak Power Output Data  
 Test Site : No.3 OATS  
 Test Mode : Mode 2 SISO B: Transmit - 802.11a 6Mbps

Channel No	Frequency (MHz)	Average Power For different Data Rate (Mbps)								Peak Power	Required Limit	Result
		6	9	12	18	24	36	48	54			
		Measurement Level (dBm)										
149	5745	21.11	--	--	--	--	--	--	--	23.81	<30dBm	Pass
157	5785	20.97	20.83	20.74	20.66	20.53	20.47	20.31	20.28	23.72	<30dBm	Pass
165	5825	21.03	--	--	--	--	--	--	--	23.63	<30dBm	Pass

Note: Peak Power Output Value = Reading value on power meter + cable loss



Product : Intel® Dual Band Wireless-AC 8260  
 Test Item : Peak Power Output Data  
 Test Site : No.3 OATS  
 Test Mode : Mode 2 SISO B: Transmit - 802.11n-20BW\_7.2Mbps(2.4G Band)

Channel No	Frequency (MHz)	Average Power For different Data Rate (Mbps)								Peak Power	Required Limit	Result
		HT0	HT1	HT2	HT3	HT4	HT5	HT6	HT7	HT0		
		Measurement Level (dBm)										
01	2412	17.69	--	--	--	--	--	--	--	22.26	<30dBm	Pass
06	2437	20.38	20.32	20.26	20.2	20.14	20.08	20.02	19.96	23.21	<30dBm	Pass
11	2462	17.40	--	--	--	--	--	--	--	22.31	<30dBm	Pass
12	2467	13.73	--	--	--	--	--	--	--	18.86	<30dBm	Pass

Note: Peak Power Output Value =Reading value on power meter + cable loss

Product : Intel® Dual Band Wireless-AC 8260  
 Test Item : Peak Power Output Data  
 Test Site : No.3 OATS  
 Test Mode : Mode 2 SISO B: Transmit - 802.11n-40BW\_15Mbps(2.4G Band)

Channel No	Frequency (MHz)	Average Power For different Data Rate (Mbps)								Peak Power	Required Limit	Result
		HT0	HT1	HT2	HT3	HT4	HT5	HT6	HT7	HT0		
		Measurement Level (dBm)										
03	2422	16.45	--	--	--	--	--	--	--	19.99	<30dBm	Pass
06	2437	17.58	17.51	17.44	17.37	17.3	17.23	17.16	17.09	20.86	<30dBm	Pass
09	2452	16.65	--	--	--	--	--	--	--	20.22	<30dBm	Pass
10	2457	12.78	--	--	--	--	--	--	--	16.34	<30dBm	Pass

Note: Peak Power Output Value = Reading value on power meter + cable loss

Product : Intel® Dual Band Wireless-AC 8260  
 Test Item : Peak Power Output Data  
 Test Site : No.3 OATS  
 Test Mode : Mode 2 SISO B: Transmit - 802.11n-20BW\_7.2Mbps(5G Band)

Channel No	Frequency (MHz)	Average Power For different Data Rate (Mbps)									Peak Power	Required Limit	Result
		HT0	HT1	HT2	HT3	HT4	HT5	HT6	HT7	HT0			
		Measurement Level (dBm)											
149	5745	21.02	--	--	--	--	--	--	--	23.84	<30dBm	Pass	
157	5785	21.10	21.06	20.97	20.86	20.74	20.63	20.58	20.44	23.78	<30dBm	Pass	
165	5825	21.51	--	--	--	--	--	--	--	23.77	<30dBm	Pass	

1. Note: Peak Power Output Value =Reading value on power meter + cable loss

Product : Intel® Dual Band Wireless-AC 8260  
 Test Item : Peak Power Output Data  
 Test Site : No.3 OATS  
 Test Mode : Mode 2 SISO B: Transmit - 802.11n-40BW\_15Mbps(5G Band)

Channel No	Frequency (MHz)	Average Power									Peak Power	Required Limit	Result
		For different Data Rate (Mbps)											
		HT0	HT1	HT2	HT3	HT4	HT5	HT6	HT7	HT0			
Measurement Level (dBm)													
151	5755	21.19	21.06	20.97	20.83	20.74	20.66	20.53	20.48	23.61	<30dBm	Pass	
159	5795	21.51	--	--	--	--	--	--	--	23.7	<30dBm	Pass	

Note: Peak Power Output Value = Reading value on power meter + cable loss

Product : Intel® Dual Band Wireless-AC 8260  
Test Item : Peak Power Output Data  
Test Site : No.3 OATS  
Test Mode : Mode 2 SISO B: Transmit - 802.11ac-80BW\_32.5Mbps(5G Band)

Channel No	Frequency (MHz)	Average Power For different Data Rate (Mbps)										Required Limit	Result
		VTH0	VTH1	VTH2	VTH3	VTH4	VTH5	VTH6	VTH7	VTH8	VTH9		
		Measurement Level (dBm)											
155	5775	21.14	20.96	20.87	20.74	20.68	20.53	20.41	20.38	20.25	20.15	<30dBm	Pass

Note: Peak Power Output Value = Reading value on power meter + cable loss

**Figure Channel 155:**

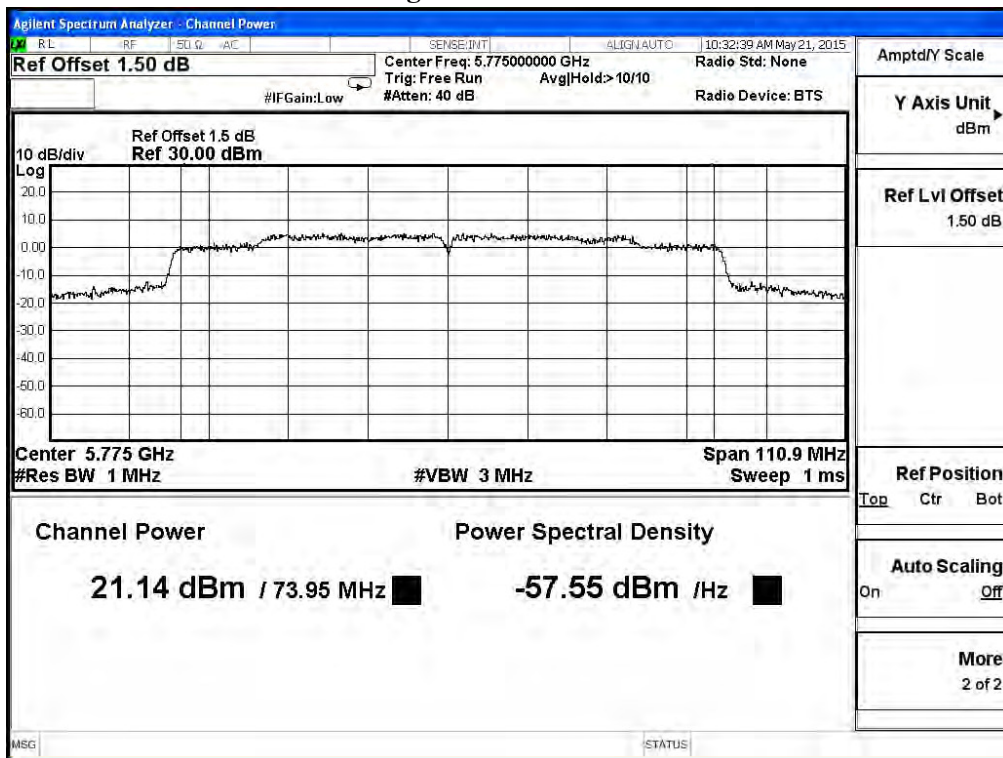

Product : Intel® Dual Band Wireless-AC 8260  
 Test Item : Peak Power Output Data  
 Test Site : No.3 OATS  
 Test Mode : Mode 3 MIMO: Transmit - 802.11n-20BW\_14.4Mbps(2.4G Band)

Chain A

Channel No	Frequency (MHz)	Average Power For different Data Rate (Mbps)								Peak Power	Required Limit	Result
		HT8	HT9	HT10	HT11	HT12	HT13	HT14	HT15	HT8		
		Measurement Level (dBm)										
01	2412	13.35	--	--	--	--	--	--	--	18.22	<30dBm	Pass
02	2417	15.71	--	--	--	--	--	--	--	20.61	<30dBm	Pass
03	2422	17.49	--	--	--	--	--	--	--	22.26	<30dBm	Pass
06	2437	17.93	17.87	17.81	17.75	17.69	17.63	17.57	17.51	22.54	<30dBm	Pass
10	2457	17.87	--	--	--	--	--	--	--	22.57	<30dBm	Pass
11	2462	16.16	--	--	--	--	--	--	--	21.25	<30dBm	Pass
12	2467	12.53	--	--	--	--	--	--	--	17.52	<30dBm	Pass

Note: Peak Power Output Value =Reading value on power meter + cable loss

Chain B

Channel No	Frequency (MHz)	Average Power For different Data Rate (Mbps)								Peak Power	Required Limit	Result
		HT8	HT9	HT10	HT11	HT12	HT13	HT14	HT15	HT8		
		Measurement Level (dBm)										
01	2412	13.36	--	--	--	--	--	--	--	18.34	<30dBm	Pass
02	2417	15.72	--	--	--	--	--	--	--	20.62	<30dBm	Pass
03	2422	17.45	--	--	--	--	--	--	--	22.03	<30dBm	Pass
06	2437	17.91	17.82	17.73	17.64	17.55	17.46	17.37	17.28	22.34	<30dBm	Pass
10	2457	17.82	--	--	--	--	--	--	--	22.36	<30dBm	Pass
11	2462	15.88	--	--	--	--	--	--	--	20.89	<30dBm	Pass
12	2467	12.34	--	--	--	--	--	--	--	17.35	<30dBm	Pass

Note: Peak Power Output Value =Reading value on power meter + cable loss

**CHAIN A+B**

Channel	Frequency (MHz)	Data Rate (Mbps)	Chain A Power (dBm)	Chain B Power (dBm)	Chain A+B Power (dBm)	Limit (dBm)	Result
1	2412	HT8	18.22	18.34	21.29	<30dBm	Pass
2	2417	HT8	20.61	20.62	23.63	<30dBm	Pass
3	2422	HT8	22.26	22.03	25.16	<30dBm	Pass
6	2437	HT8	22.54	22.34	25.45	<30dBm	Pass
10	2457	HT8	22.57	22.36	25.48	<30dBm	Pass
11	2462	HT8	21.25	20.89	24.08	<30dBm	Pass
12	2467	HT8	17.52	17.35	20.45	<30dBm	Pass

Note: Peak Power Output Value (dBm) = 10\*LOG (Chain A (mW) + Chain B (mW))

Product : Intel® Dual Band Wireless-AC 8260  
 Test Item : Peak Power Output Data  
 Test Site : No.3 OATS  
 Test Mode : Mode 3 MIMO: Transmit - 802.11n-40BW\_30Mbps(2.4G Band)

## Chain A

Channel No	Frequency (MHz)	Average Power For different Data Rate (Mbps)								Peak Power	Required Limit	Result
		HT8	HT9	HT10	HT11	HT12	HT13	HT14	HT15	HT8		
		Measurement Level (dBm)										
03	2422	13.59	--	--	--	--	--	--	--	17.26	<30dBm	Pass
04	2427	13.95	--	--	--	--	--	--	--	17.57	<30dBm	Pass
05	2432	14.21	--	--	--	--	--	--	--	17.81	<30dBm	Pass
06	2437	15.20	15.17	15.14	15.11	15.08	15.05	15.02	14.99	18.77	<30dBm	Pass
09	2452	15.05	--	--	--	--	--	--	--	18.70	<30dBm	Pass
10	2457	11.61	--	--	--	--	--	--	--	15.23	<30dBm	Pass

Note: Peak Power Output Value = Reading value on power meter + cable loss

## Chain B

Channel No	Frequency (MHz)	Average Power For different Data Rate (Mbps)								Peak Power	Required Limit	Result
		HT8	HT9	HT10	HT11	HT12	HT13	HT14	HT15	HT8		
		Measurement Level (dBm)										
03	2422	13.56	--	--	--	--	--	--	--	17.23	<30dBm	Pass
04	2427	13.92	--	--	--	--	--	--	--	17.51	<30dBm	Pass
05	2432	14.19	--	--	--	--	--	--	--	17.83	<30dBm	Pass
06	2437	15.16	15.11	15.06	15.01	14.96	14.91	14.86	14.81	18.74	<30dBm	Pass
09	2452	15.03	--	--	--	--	--	--	--	18.64	<30dBm	Pass
10	2457	11.58	--	--	--	--	--	--	--	15.23	<30dBm	Pass

Note: Peak Power Output Value = Reading value on power meter + cable loss



**CHAIN A+B**

Channel	Frequency (MHz)	Data Rata (Mbps)	Chain A Power (dBm)	Chain B Power (dBm)	Chain A+B Power (dBm)	Limit (dBm)	Result
3	2422	HT8	17.26	17.23	20.26	<30dBm	Pass
4	2427	HT8	17.57	17.51	20.55	<30dBm	Pass
5	2432	HT8	17.81	17.83	20.83	<30dBm	Pass
6	2437	HT8	18.77	18.74	21.77	<30dBm	Pass
9	2452	HT8	18.70	18.64	21.68	<30dBm	Pass
10	2457	HT8	15.23	15.23	18.24	<30dBm	Pass

Note: Peak Power Output Value (dBm) = 10\*LOG (Chain A (mW) + Chain B (mW))

Product : Intel® Dual Band Wireless-AC 8260  
 Test Item : Peak Power Output Data  
 Test Site : No.3 OATS  
 Test Mode : Mode 3 MIMO: Transmit - 802.11n-20BW\_14.4Mbps(5G Band)

**Chain A**

Channel No	Frequency (MHz)	Average Power For different Data Rate (Mbps)									Peak Power	Required Limit	Result
		HT8	HT9	HT10	HT11	HT12	HT13	HT14	HT15	HT8			
		Measurement Level (dBm)											
149	5745	18.30	--	--	--	--	--	--	--	22.68	<30dBm	Pass	
157	5785	18.39	18.28	18.17	18.06	17.94	17.83	17.71	17.63	22.51	<30dBm	Pass	
165	5825	18.42	--	--	--	--	--	--	--	22.57	<30dBm	Pass	

Note: Peak Power Output Value =Reading value on power meter + cable loss

**Chain B**

Channel No	Frequency (MHz)	Average Power For different Data Rate (Mbps)									Peak Power	Required Limit	Result
		HT8	HT9	HT10	HT11	HT12	HT13	HT14	HT15	HT8			
		Measurement Level (dBm)											
149	5745	18.11	--	--	--	--	--	--	--	22.83	<30dBm	Pass	
157	5785	18.17	18.06	17.96	17.84	17.73	17.66	17.57	17.48	22.56	<30dBm	Pass	
165	5825	18.27	--	--	--	--	--	--	--	22.54	<30dBm	Pass	

Note: Peak Power Output Value =Reading value on power meter + cable loss

**CHAIN A+B**

Channel	Frequency (MHz)	Data Rata (Mbps)	Chain A Power (dBm)	Chain B Power (dBm)	Chain A+B Power (dBm)	Limit (dBm)	Result
149	5745	HT8	22.68	22.83	25.77	<30dBm	Pass
157	5785	HT8	22.51	22.56	25.55	<30dBm	Pass
165	5825	HT8	22.57	22.54	25.57	<30dBm	Pass

Note: Peak Power Output Value (dBm) = 10\*LOG (Chain A (mW) + Chain B (mW))

Product : Intel® Dual Band Wireless-AC 8260  
 Test Item : Peak Power Output Data  
 Test Site : No.3 OATS  
 Test Mode : Mode 3 MIMO: Transmit - 802.11n-40BW\_30Mbps(5G Band)

**Chain A**

Channel No	Frequency (MHz)	Average Power For different Data Rate (Mbps)									Peak Power	Required Limit	Result
		HT8	HT9	HT10	HT11	HT12	HT13	HT14	HT15	HT8			
		Measurement Level (dBm)											
151	5755	18.17	--	--	--	--	--	--	--	22.04	<30dBm	Pass	
159	5795	18.41	18.36	18.24	18.16	18.05	17.94	17.82	17.74	22.27	<30dBm	Pass	

Note: Peak Power Output Value =Reading value on power meter + cable loss

**Chain B**

Channel No	Frequency (MHz)	Average Power For different Data Rate (Mbps)									Peak Power	Required Limit	Result
		HT8	HT9	HT10	HT11	HT12	HT13	HT14	HT15	HT8			
		Measurement Level (dBm)											
151	5755	18.31	--	--	--	--	--	--	--	22.42	<30dBm	Pass	
159	5795	18.21	18.17	18.03	17.94	17.82	17.71	17.63	17.52	22.27	<30dBm	Pass	

Note: Peak Power Output Value =Reading value on power meter + cable loss

**CHAIN A+B**

Channel	Frequency (MHz)	Data Rata (Mbps)	Chain A Power (dBm)	Chain B Power (dBm)	Chain A+B Power (dBm)	Limit (dBm)	Result
151	5755	HT8	22.04	22.42	25.24	<30dBm	Pass
159	5795	HT8	22.27	22.27	25.28	<30dBm	Pass

Note: Peak Power Output Value (dBm) = 10\*LOG (Chain A (mW) + Chain B (mW))

Product : Intel® Dual Band Wireless-AC 8260  
 Test Item : Peak Power Output Data  
 Test Site : No.3 OATS  
 Test Mode : Mode 3 MIMO: Transmit - 802.11ac-80BW\_65Mbps(5G Band)

Chain A

Channel No	Frequency (MHz)	Average Power For different Data Rate (Mbps)										Required Limit	Result
		VTH0	VTH1	VTH2	VTH3	VTH4	VTH5	VTH6	VTH7	VTH8	VTH9		
		Measurement Level (dBm)											
155	5775	18.13	17.94	17.83	17.74	17.63	17.52	17.44	17.34	17.24	17.14	<30dBm	Pass

Note: Peak Power Output Value = Reading value on power meter + cable loss

Figure Channel 155:

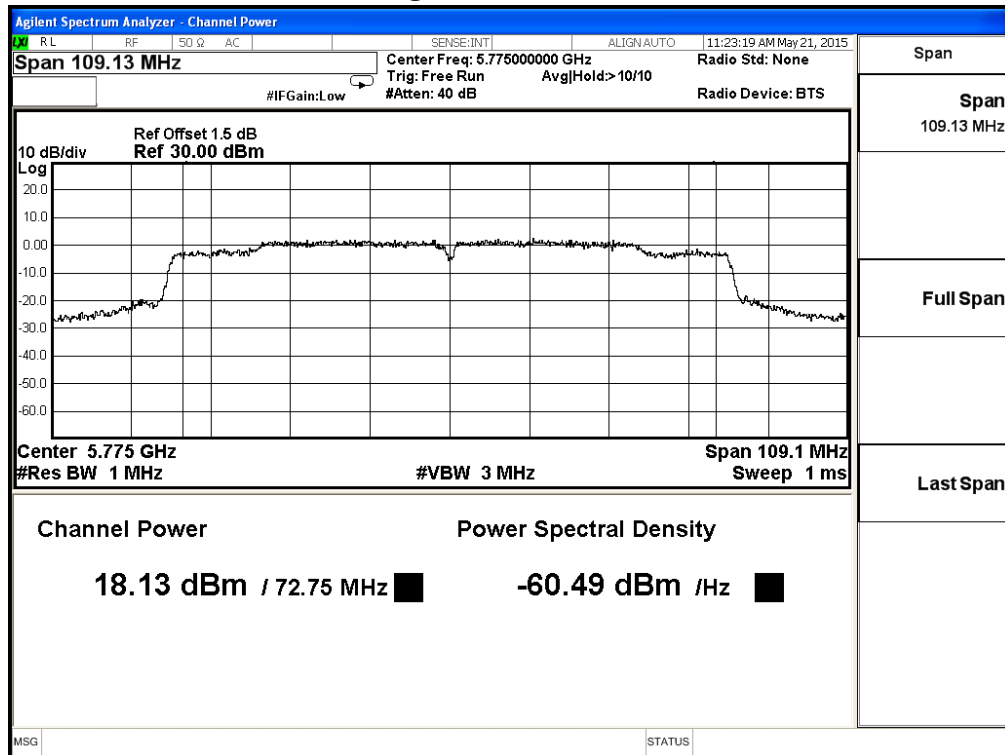

Product : Intel® Dual Band Wireless-AC 8260  
 Test Item : Peak Power Output Data  
 Test Site : No.3 OATS  
 Test Mode : Mode 3 MIMO: Transmit - 802.11ac-80BW\_65Mbps(5G Band)

Chain B

Channel No	Frequency (MHz)	Average Power										Required Limit	Result
		For different Data Rate (Mbps)											
		VTH0	VTH1	VTH2	VTH3	VTH4	VTH5	VTH6	VTH7	VTH8	VTH9		
Measurement Level (dBm)													
155	5775	18.26	17.93	17.82	17.77	17.65	17.57	17.42	17.33	17.23	17.13	<30dBm	Pass

Note: Peak Power Output Value = Reading value on power meter + cable loss

Figure Channel 155:

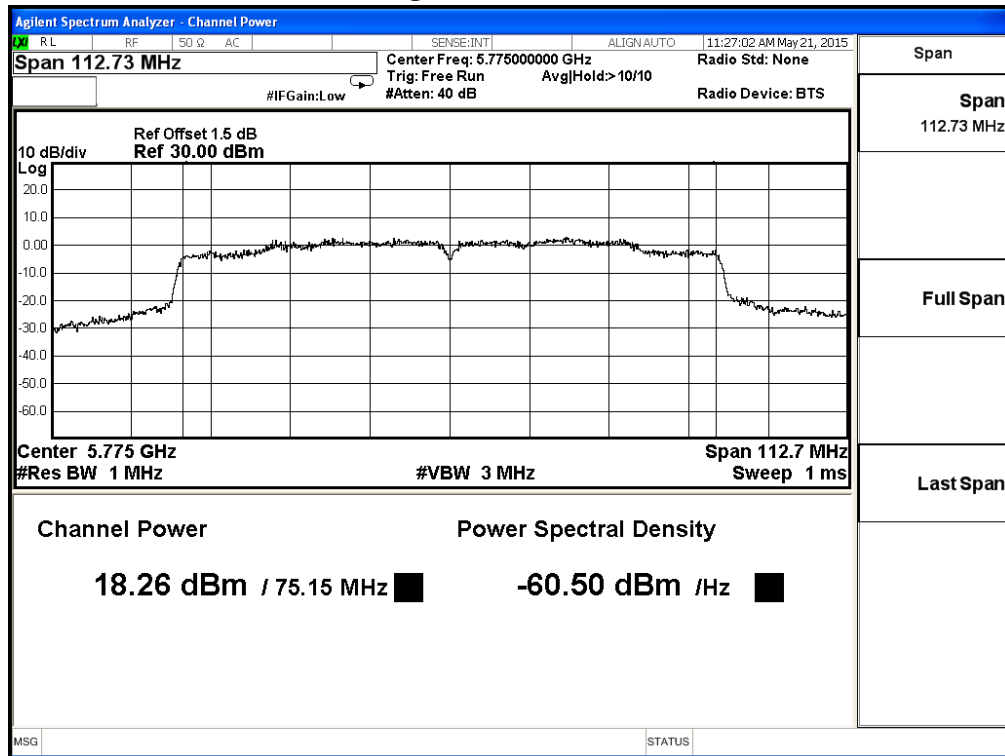

**CHAIN A+B**

Channel	Frequency (MHz)	Data Rata (Mbps)	Chain A Power (dBm)	Chain B Power (dBm)	Chain A+B Power (dBm)	Limit (dBm)	Result
155	5775	VTH0	18.13	18.26	21.20	<30dBm	Pass

Note: Peak Power Output Value (dBm) = 10\*LOG (Chain A (mW) + Chain B (mW))

Product : Intel® Dual Band Wireless-AC 8260  
 Test Item : Peak Power Output Data  
 Test Site : No.3 OATS  
 Test Mode : Mode 4 Beamforming: Transmit - 802.11n-20BW\_14.4Mbps(2.4G Band)

Chain A

Channel No	Frequency (MHz)	Average Power For different Data Rate (Mbps)								Peak Power	Required Limit	Result
		HT0	HT1	HT2	HT3	HT4	HT5	HT6	HT7			
		Measurement Level (dBm)										
01	2412	15.12	--	--	--	--	--	--	--	20.05	<30dBm	Pass
02	2417	17.95	--	--	--	--	--	--	--	22.47	<30dBm	Pass
06	2437	18.04	17.97	17.9	17.83	17.76	17.69	17.62	17.55	22.41	<30dBm	Pass
10	2457	17.49	--	--	--	--	--	--	--	22.22	<30dBm	Pass
11	2462	15.23	--	--	--	--	--	--	--	20.24	<30dBm	Pass
12	2467	10.24	--	--	--	--	--	--	--	15.20	<30dBm	Pass

Note: Peak Power Output Value =Reading value on power meter + cable loss

Chain B

Channel No	Frequency (MHz)	Average Power For different Data Rate (Mbps)								Peak Power	Required Limit	Result
		HT0	HT1	HT2	HT3	HT4	HT5	HT6	HT7			
		Measurement Level (dBm)										
01	2412	15.18	--	--	--	--	--	--	--	20.08	<30dBm	Pass
02	2417	18.00	--	--	--	--	--	--	--	22.34	<30dBm	Pass
06	2437	18.04	17.97	17.9	17.83	17.76	17.69	17.62	17.55	22.41	<30dBm	Pass
10	2457	17.45	--	--	--	--	--	--	--	22.21	<30dBm	Pass
11	2462	14.96	--	--	--	--	--	--	--	20.01	<30dBm	Pass
12	2467	10.01								14.94	<30dBm	Pass

Note: Peak Power Output Value =Reading value on power meter + cable loss

**CHAIN A+B**

Channel	Frequency (MHz)	Data Rata (Mbps)	Chain A Power (dBm)	Chain B Power (dBm)	Chain A+B Power (dBm)	Limit (dBm)	Result
1	2412	HT0	20.05	20.08	23.08	<30dBm	Pass
2	2417	HT0	22.47	22.34	25.42	<30dBm	Pass
6	2437	HT0	22.41	22.41	25.42	<30dBm	Pass
10	2457	HT0	22.22	22.21	25.23	<30dBm	Pass
11	2462	HT0	20.24	20.01	23.14	<30dBm	Pass
12	2467	HT0	15.20	14.94	18.08	<30dBm	Pass

Note: Peak Power Output Value (dBm) = 10\*LOG (Chain A (mW) + Chain B (mW))



Product : Intel® Dual Band Wireless-AC 8260  
 Test Item : Peak Power Output Data  
 Test Site : No.3 OATS  
 Test Mode : Mode 4 Beamforming: Transmit - 802.11n-40BW\_30Mbps(2.4G Band)

Chain A

Channel No	Frequency (MHz)	Average Power For different Data Rate (Mbps)								Peak Power	Required Limit	Result
		HT0	HT1	HT2	HT3	HT4	HT5	HT6	HT7	HT0		
		Measurement Level (dBm)										
03	2422	12.96	--	--	--	--	--	--	--	16.51	<30dBm	Pass
04	2427	13.61	--	--	--	--	--	--	--	17.02	<30dBm	Pass
06	2437	14.62	14.57	14.52	14.47	14.42	14.37	14.32	14.27	18.02	<30dBm	Pass
09	2452	13.99	--	--	--	--	--	--	--	17.46	<30dBm	Pass
10	2457	9.15	--	--	--	--	--	--	--	12.73	<30dBm	Pass

Note: Peak Power Output Value =Reading value on power meter + cable loss

Chain B

Channel No	Frequency (MHz)	Average Power For different Data Rate (Mbps)								Peak Power	Required Limit	Result
		HT0	HT1	HT2	HT3	HT4	HT5	HT6	HT7	HT0		
		Measurement Level (dBm)										
03	2422	12.97	--	--	--	--	--	--	--	16.41	<30dBm	Pass
04	2427	13.62	--	--	--	--	--	--	--	17.05	<30dBm	Pass
06	2437	14.60	14.54	14.48	14.42	14.36	14.3	14.24	14.18	17.95	<30dBm	Pass
09	2452	13.97	--	--	--	--	--	--	--	17.47	<30dBm	Pass
10	2457	9.02	--	--	--	--	--	--	--	12.56	<30dBm	Pass

Note: Peak Power Output Value =Reading value on power meter + cable loss

**CHAIN A+B**

Channel	Frequency (MHz)	Data Rata (Mbps)	Chain A Power (dBm)	Chain B Power (dBm)	Chain A+B Power (dBm)	Limit (dBm)	Result
3	2422	HT0	16.51	16.41	19.47	<30dBm	Pass
4	2427	HT0	17.02	17.05	20.05	<30dBm	Pass
6	2437	HT0	18.02	17.95	21.00	<30dBm	Pass
9	2452	HT0	17.46	17.47	20.48	<30dBm	Pass
10	2457	HT0	12.73	12.56	15.66	<30dBm	Pass

Note: Peak Power Output Value (dBm) = 10\*LOG (Chain A (mW) + Chain B (mW))

Product : Intel® Dual Band Wireless-AC 8260  
 Test Item : Peak Power Output Data  
 Test Site : No.3 OATS  
 Test Mode : Mode 4 Beamforming: Transmit - 802.11n-20BW\_14.4Mbps(5G Band)

**Chain A**

Channel No	Frequency (MHz)	Average Power For different Data Rate (Mbps)									Peak Power	Required Limit	Result
		HT0	HT1	HT2	HT3	HT4	HT5	HT6	HT7	HT0			
		Measurement Level (dBm)											
149	5745	18.26	--	--	--	--	--	--	--	22.61	<30dBm	Pass	
157	5785	18.31	18.26	18.17	18.03	17.94	17.86	17.73	17.69	22.58	<30dBm	Pass	
165	5825	18.44	--	--	--	--	--	--	--	22.60	<30dBm	Pass	

Note: Peak Power Output Value =Reading value on power meter + cable loss

**Chain B**

Channel No	Frequency (MHz)	Average Power For different Data Rate (Mbps)									Peak Power	Required Limit	Result
		HT0	HT1	HT2	HT3	HT4	HT5	HT6	HT7	HT0			
		Measurement Level (dBm)											
149	5745	18.03	--	--	--	--	--	--	--	22.81	<30dBm	Pass	
157	5785	18.05	17.94	17.83	17.74	17.62	17.55	17.48	17.34	22.88	<30dBm	Pass	
165	5825	18.51	--	--	--	--	--	--	--	22.57	<30dBm	Pass	

Note: Peak Power Output Value =Reading value on power meter + cable loss

**CHAIN A+B**

Channel	Frequency (MHz)	Data Rata (Mbps)	Chain A Power (dBm)	Chain B Power (dBm)	Chain A+B Power (dBm)	Limit (dBm)	Result
149	5745	HT8	22.61	22.81	25.72	<30dBm	Pass
157	5785	HT8	22.58	22.88	25.74	<30dBm	Pass
165	5825	HT8	22.60	22.57	25.60	<30dBm	Pass

Note: Peak Power Output Value (dBm) = 10\*LOG (Chain A (mW)+ Chain B (mW))

Product : Intel® Dual Band Wireless-AC 8260  
 Test Item : Peak Power Output Data  
 Test Site : No.3 OATS  
 Test Mode : Mode 4 Beamforming: Transmit - 802.11n-40BW\_30Mbps(5G Band)

**Chain A**

Channel No	Frequency (MHz)	Average Power For different Data Rate (Mbps)									Peak Power	Required Limit	Result
		HT0	HT1	HT2	HT3	HT4	HT5	HT6	HT7	HT0			
		Measurement Level (dBm)											
151	5755	18.44	--	--	--	--	--	--	--	22.05	<30dBm	Pass	
159	5795	18.56	18.46	18.37	18.25	18.14	18.07	17.97	17.83	22.18	<30dBm	Pass	

Note: Peak Power Output Value =Reading value on power meter + cable loss

**Chain B**

Channel No	Frequency (MHz)	Average Power For different Data Rate (Mbps)									Peak Power	Required Limit	Result
		HT0	HT1	HT2	HT3	HT4	HT5	HT6	HT7	HT0			
		Measurement Level (dBm)											
151	5755	18.03	--	--	--	--	--	--	--	21.90	<30dBm	Pass	
159	5795	18.41	18.33	18.27	18.17	18.06	17.94	17.86	17.77	22.14	<30dBm	Pass	

Note: Peak Power Output Value =Reading value on power meter + cable loss

**CHAIN A+B**

Channel	Frequency (MHz)	Data Rata (Mbps)	Chain A Power (dBm)	Chain B Power (dBm)	Chain A+B Power (dBm)	Limit (dBm)	Result
151	5755	HT8	22.05	21.90	24.99	<30dBm	Pass
159	5795	HT8	22.18	22.14	25.17	<30dBm	Pass

Note: Peak Power Output Value (dBm) = 10\*LOG (Chain A (mW) + Chain B (mW))

Product : Intel® Dual Band Wireless-AC 8260  
 Test Item : Peak Power Output Data  
 Test Site : No.3 OATS  
 Test Mode : Mode 4 Beamforming: Transmit - 802.11ac-80BW\_65Mbps(5G Band)

Chain A

Channel No	Frequency (MHz)	Average Power For different Data Rate (Mbps)										Required Limit	Result
		VTH0	VTH1	VTH2	VTH3	VTH4	VTH5	VTH6	VTH7	VTH8	VTH9		
		Measurement Level (dBm)											
155	5775	18.17	17.94	17.82	17.74	17.63	17.52	17.48	17.34	17.25	17.15	<30dBm	Pass

Note: Peak Power Output Value = Reading value on power meter + cable loss

Figure Channel 155:

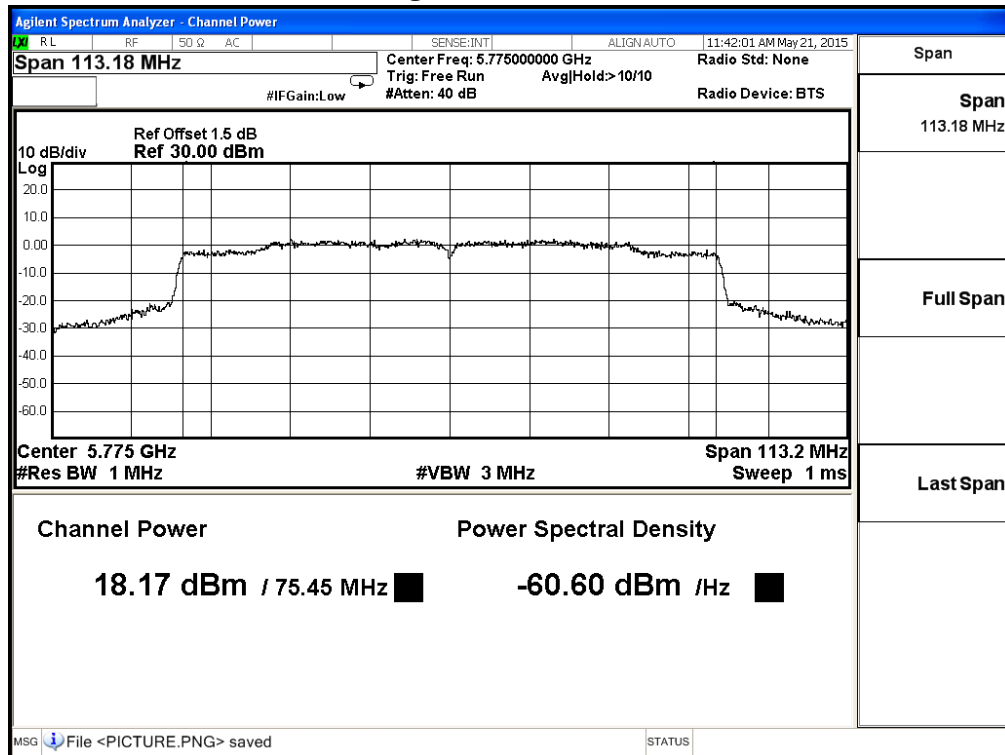

Product : Intel® Dual Band Wireless-AC 8260  
 Test Item : Peak Power Output Data  
 Test Site : No.3 OATS  
 Test Mode : Mode 4 Beamforming: Transmit - 802.11ac-80BW\_65Mbps(5G Band)

Chain B

Channel No	Frequency (MHz)	Average Power For different Data Rate (Mbps)										Required Limit	Result
		VTH0	VTH1	VTH2	VTH3	VTH4	VTH5	VTH6	VTH7	VTH8	VTH9		
		Measurement Level (dBm)											
155	5775	18.15	17.93	17.84	17.73	17.65	17.52	17.48	17.34	17.24	17.14	<30dBm	Pass

Note: Peak Power Output Value = Reading value on power meter + cable loss

Figure Channel 155:

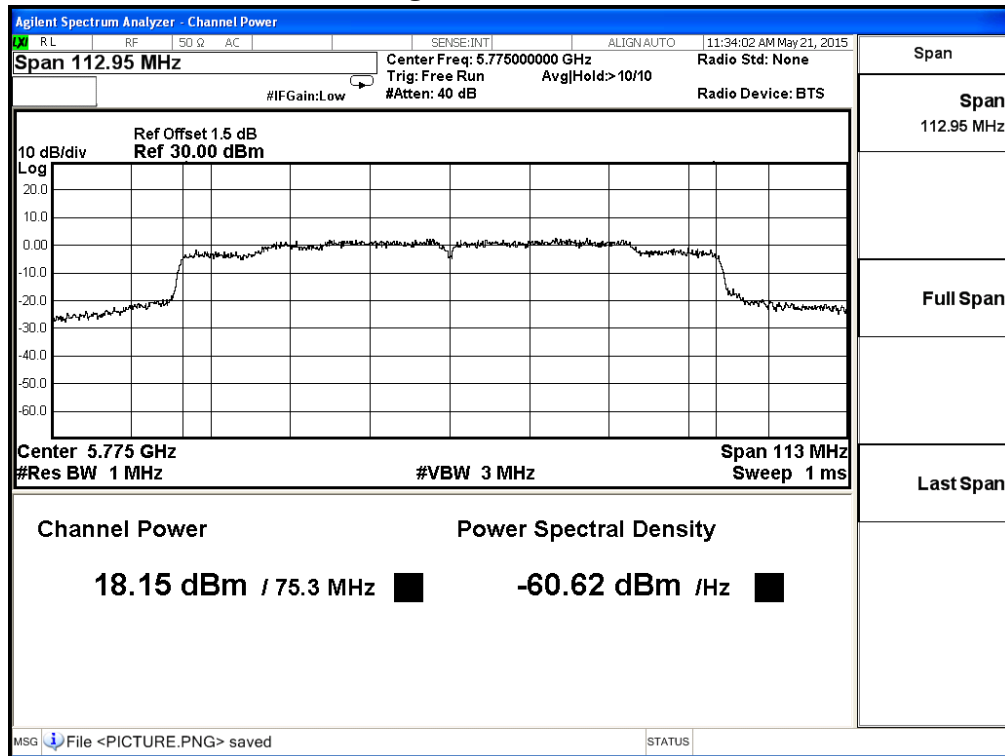

**CHAIN A+B**

Channel	Frequency (MHz)	Data Rata (Mbps)	Chain A Power (dBm)	Chain B Power (dBm)	Chain A+B Power (dBm)	Limit (dBm)	Result
155	5775	VTH0	18.17	18.15	21.17	<30dBm	Pass

Note: Peak Power Output Value (dBm) = 10\*LOG (Chain A (mW) + Chain B (mW))

#### 4. Radiated Emission

##### 4.1. Test Equipment

The following test equipments are used during the radiated emission test:

Test Site		Equipment	Manufacturer	Model No./Serial No.	Last Cal.
☒ Site # 3	X	Magnetic Loop Antenna	Teseq	HLA6121/ 37133	Sep, 2014
	X	Bilog Antenna	Schaffner Chase	CBL6112B/ 2707	Jun, 2014
	X	EMI Test Receiver	R&S	ESCS 30/838251/ 001	Jun, 2014
	X	Coaxial Cable	QTK(Arnist)	RG 214/ LC003-RG	Jun, 2014
	X	Coaxial signal switch	Arnist	MP59B/ 6200798682	Jun, 2014

Test Site		Equipment	Manufacturer	Model No./Serial No.	Last Cal.
☒ CB # 8	X	Spectrum Analyzer	R&S	FSP40/ 100339	Oct, 2014
	X	Horn Antenna	ETS-Lindgren	3117/ 35205	Mar., 2015
	X	Horn Antenna	Schwarzbeck	BBHA9170/209	Jan, 2015
	X	Horn Antenna	TRC	AH-0801/95051	Aug, 2014
	X	Pre-Amplifier	EMCI	EMC012630SE/980210	Jan, 2015
	X	Pre-Amplifier	MITEQ	JS41-001040000-58-5P/153945	Jul, 2014
	X	Pre-Amplifier	NARDA	DBL-1840N506/013	Jul, 2014

- Note: 1. All equipments are calibrated with traceable calibrations. Each calibration is traceable to the national or international standards.  
2. The test instruments marked with "X" are used to measure the final test results.



## 4.2. Test Setup

### Radiated Emission Below 1GHz

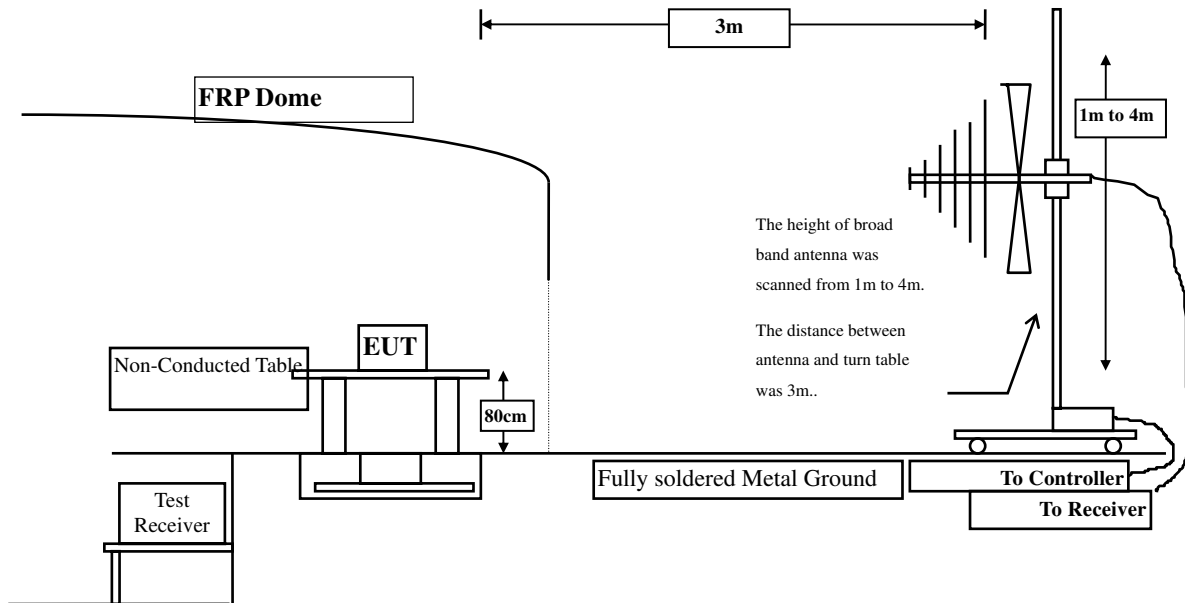

### Radiated Emission Above 1GHz

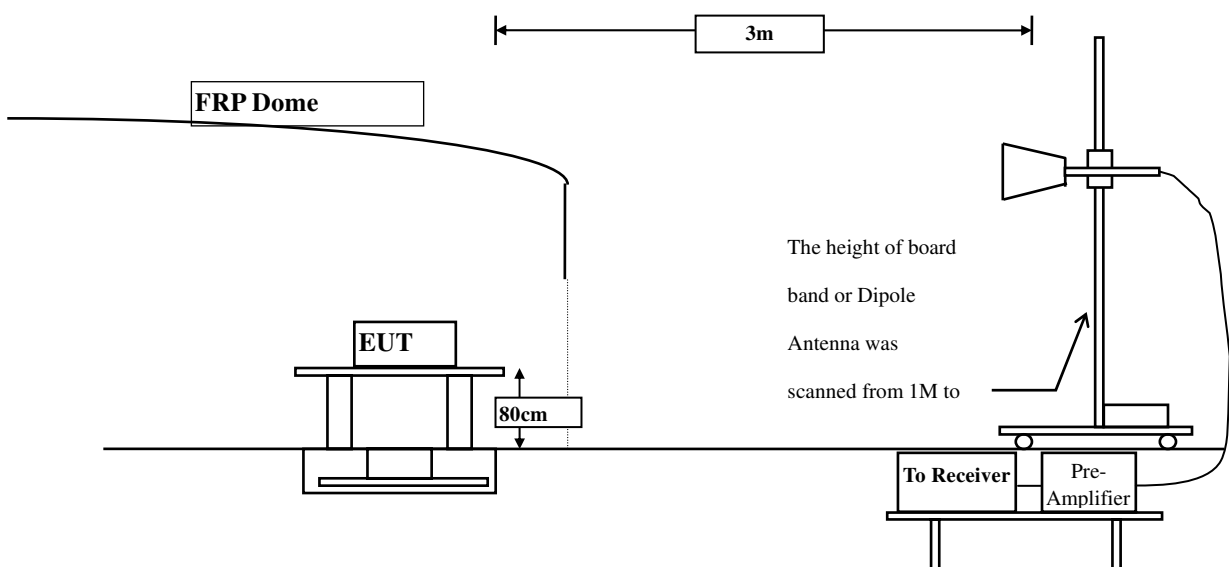

### 4.3. Limits

Emissions radiated outside of the specified frequency bands, except for harmonics, shall be attenuated by at least 20dB below the level of the fundamental or to the general radiated emission limits in paragraph 15.209, whichever is the lesser attenuation.

<b>FCC Part 15 Subpart C Paragraph 15.209(a) Limits</b>		
Frequency MHz	Field strength (microvolts/meter)	Measurement distance (meter)
0.009-0.490	2400/F(kHz)	300
0.490-1.705	24000/F(kHz)	30
1.705-30	30	30
30-88	100	3
88-216	150	3
216-960	200	3
Above 960	500	3

Remarks: E field strength (dBuV/m) = 20 log E field strength (uV/m)

#### **4.4. Test Procedure**

The EUT was setup according to ANSI C63.10: 2009 and tested according to DTS test procedure of KDB558074 for compliance to FCC 47CFR 15.247 requirements.

Measuring the frequency range below 1GHz, the EUT is placed on a turn table which is 0.8 meter above ground, when measuring the frequency range above 1GHz, the EUT is placed on a turn table which is 0.8 meter above ground.

The turn table is rotated 360 degrees to determine the position of the maximum emission level.

The EUT was positioned such that the distance from antenna to the EUT was 3 meters.

The antenna is scanned between 1 meter and 4 meters to find out the maximum emission level. This is repeated for both horizontal and vertical polarization of the antenna. In order to find the maximum emission, all of the interface cables were manipulated according to ANSI C63.10: 2009 on radiated measurement.

The resolution bandwidth below 30MHz setting on the field strength meter is 9kHz and 30MHz~1GHz is 120kHz and above 1GHz is 1MHz.

Radiated emission measurements below 30MHz are made using Loop Antenna and 30MHz~1GHz are made using broadband Bilog antenna and above 1GHz are made using Horn Antennas.

The measurement is divided into the Preliminary Measurement and the Final Measurement.

The suspected frequencies are searched for in Preliminary Measurement with the measurement antenna kept pointed at the source of the emission both in azimuth and elevation, with the polarization of the antenna oriented for maximum response. The antenna is pointed at an angle towards the source of the emission, and the EUT is rotated in both height and polarization to maximize the measured emission. The emission is kept within the illumination area of the 3 dB bandwidth of the antenna.

The worst radiated emission is measured in the Open Area Test Site on the Final Measurement.

The measurement frequency range from 9kHz - 10th Harmonic of fundamental was investigated.

#### **4.5. Uncertainty**

± 3.9 dB above 1GHz

± 3.8 dB below 1GHz

**4.6. Test Result of Radiated Emission**

Product : Intel® Dual Band Wireless-AC 8260  
 Test Item : Harmonic Radiated Emission Data  
 Test Site : No.3 OATS  
 Test Mode : Mode 1 SISO A: Transmit (802.11b 1Mbps) (2412MHz)

Frequency MHz	Correct Factor dB	Reading Level dBuV	Measurement Level dBuV/m	Margin dB	Limit dBuV/m
<b>Horizontal</b>					
<b>Peak Detector:</b>					
4824.000	3.261	39.560	42.821	-31.179	74.000
7236.000	10.650	37.150	47.800	-26.200	74.000
9648.000	13.337	37.360	50.696	-23.304	74.000
<b>Average Detector:</b>					
--					
<b>Vertical</b>					
<b>Peak Detector:</b>					
4824.000	6.421	42.520	48.941	-25.059	74.000
7236.000	11.495	36.180	47.675	-26.325	74.000
9648.000	13.807	37.410	51.216	-22.784	74.000
<b>Average Detector:</b>					
--					

Note:

1. All Readings below 1GHz are Quasi-Peak, above 1GHz are performed with peak and/or average measurements as necessary.
2. Peak measurements: RBW = 1MHz, VBW = 3 MHz, Sweep: Auto.
3. Average measurements: RBW = 1MHz, VBW = 10 Hz, Sweep: Auto.
4. Measurement Level = Reading Level + Correct Factor.
5. Correct Factor = Antenna factor + Cable loss – Amplifier gain.
6. The average measurement was not performed when the peak measured data under the limit of average detection.
7. The emission levels of other frequencies are very lower than the limit and not show in test report.

Product : Intel® Dual Band Wireless-AC 8260  
 Test Item : Harmonic Radiated Emission Data  
 Test Site : No.3 OATS  
 Test Mode : Mode 1 SISO A: Transmit (802.11b 1Mbps) (2437 MHz)

Frequency MHz	Correct Factor dB	Reading Level dBuV	Measurement Level dBuV/m	Margin dB	Limit dBuV/m
<b>Horizontal</b>					
<b>Peak Detector:</b>					
4874.000	3.038	39.670	42.707	-31.293	74.000
7311.000	11.795	36.840	48.634	-25.366	74.000
9748.000	12.635	37.650	50.285	-23.715	74.000
<b>Average Detector:</b>					
--					
<b>Vertical</b>					
<b>Peak Detector:</b>					
4874.000	5.812	42.120	47.931	-26.069	74.000
7311.000	12.630	37.880	50.509	-23.491	74.000
9748.000	13.126	37.210	50.336	-23.664	74.000
<b>Average Detector:</b>					
--					

Note:

1. All Readings below 1GHz are Quasi-Peak, above 1GHz are performed with peak and/or average measurements as necessary.
2. Peak measurements: RBW = 1MHz, VBW = 3 MHz, Sweep: Auto.
3. Average measurements: RBW = 1MHz, VBW = 10 Hz, Sweep: Auto.
4. Measurement Level = Reading Level + Correct Factor.
5. Correct Factor = Antenna factor + Cable loss – Amplifier gain.
6. The average measurement was not performed when the peak measured data under the limit of average detection.
7. The emission levels of other frequencies are very lower than the limit and not show in test report.

Product : Intel® Dual Band Wireless-AC 8260  
 Test Item : Harmonic Radiated Emission Data  
 Test Site : No.3 OATS  
 Test Mode : Mode 1 SISO A: Transmit (802.11b 1Mbps) (2462 MHz)

Frequency MHz	Correct Factor dB	Reading Level dBuV	Measurement Level dBuV/m	Margin dB	Limit dBuV/m
<b>Horizontal</b>					
<b>Peak Detector:</b>					
4924.000	2.858	40.120	42.977	-31.023	74.000
7386.000	12.127	37.250	49.378	-24.622	74.000
9848.000	12.852	36.750	49.603	-24.397	74.000
<b>Average Detector:</b>					
--					
<b>Vertical</b>					
<b>Peak Detector:</b>					
4924.000	5.521	41.870	47.390	-26.610	74.000
7386.000	13.254	37.680	50.934	-23.066	74.000
9848.000	13.367	37.460	50.827	-23.173	74.000
<b>Average Detector:</b>					
--					

Note:

1. All Readings below 1GHz are Quasi-Peak, above 1GHz are performed with peak and/or average measurements as necessary.
2. Peak measurements: RBW = 1MHz, VBW = 3 MHz, Sweep: Auto.
3. Average measurements: RBW = 1MHz, VBW = 10 Hz, Sweep: Auto.
4. Measurement Level = Reading Level + Correct Factor.
5. Correct Factor = Antenna factor + Cable loss – Amplifier gain.
6. The average measurement was not performed when the peak measured data under the limit of average detection.
7. The emission levels of other frequencies are very lower than the limit and not show in test report.

Product : Intel® Dual Band Wireless-AC 8260  
 Test Item : Harmonic Radiated Emission Data  
 Test Site : No.3 OATS  
 Test Mode : Mode 1 SISO A: Transmit (802.11b 1Mbps) (2467 MHz)

Frequency MHz	Correct Factor dB	Reading Level dBuV	Measurement Level dBuV/m	Margin dB	Limit dBuV/m
<b>Horizontal</b>					
<b>Peak Detector:</b>					
4934.000	2.830	37.560	40.391	-33.609	74.000
7401.000	12.218	36.840	49.058	-24.942	74.000
9868.000	13.043	36.210	49.252	-24.748	74.000
<b>Average Detector:</b>					
--					
<b>Vertical</b>					
<b>Peak Detector:</b>					
4934.000	5.530	37.610	43.141	-30.859	74.000
7401.000	13.345	36.840	50.186	-23.814	74.000
9868.000	13.602	36.840	50.441	-23.559	74.000
<b>Average Detector:</b>					
--					

Note:

1. All Readings below 1GHz are Quasi-Peak, above 1GHz are performed with peak and/or average measurements as necessary.
2. Peak measurements: RBW = 1MHz, VBW = 3 MHz, Sweep: Auto.
3. Average measurements: RBW = 1MHz, VBW = 10 Hz, Sweep: Auto.
4. Measurement Level = Reading Level + Correct Factor.
5. Correct Factor = Antenna factor + Cable loss – Amplifier gain.
6. The average measurement was not performed when the peak measured data under the limit of average detection.
7. The emission levels of other frequencies are very lower than the limit and not show in test report.

Product : Intel® Dual Band Wireless-AC 8260  
 Test Item : Harmonic Radiated Emission Data  
 Test Site : No.3 OATS  
 Test Mode : Mode 1 SISO A: Transmit (802.11g 6Mbps) (2412MHz)

Frequency MHz	Correct Factor dB	Reading Level dBuV	Measurement Level dBuV/m	Margin dB	Limit dBuV/m
<b>Horizontal</b>					
<b>Peak Detector:</b>					
4824.000	3.261	39.840	43.101	-30.899	74.000
7236.000	10.650	39.450	50.100	-23.900	74.000
9648.000	13.337	37.260	50.596	-23.404	74.000
<b>Average Detector:</b>					
--					
<b>Vertical</b>					
<b>Peak Detector:</b>					
4824.000	6.421	41.260	47.681	-26.319	74.000
7236.000	11.495	39.120	50.615	-23.385	74.000
9648.000	13.807	36.840	50.646	-23.354	74.000
<b>Average Detector:</b>					
--					

Note:

1. All Readings below 1GHz are Quasi-Peak, above 1GHz are performed with peak and/or average measurements as necessary.
2. Peak measurements: RBW = 1MHz, VBW = 3 MHz, Sweep: Auto.
3. Average measurements: RBW = 1MHz, VBW = 10 Hz, Sweep: Auto.
4. Measurement Level = Reading Level + Correct Factor.
5. Correct Factor = Antenna factor + Cable loss – Amplifier gain.
6. The average measurement was not performed when the peak measured data under the limit of average detection.
7. The emission levels of other frequencies are very lower than the limit and not show in test report.



Product : Intel® Dual Band Wireless-AC 8260  
 Test Item : Harmonic Radiated Emission Data  
 Test Site : No.3 OATS  
 Test Mode : Mode 1 SISO A: Transmit (802.11g 6Mbps) (2437 MHz)

Frequency MHz	Correct Factor dB	Reading Level dBuV	Measurement Level dBuV/m	Margin dB	Limit dBuV/m
<b>Horizontal</b>					
<b>Peak Detector:</b>					
4874.000	3.038	39.850	42.887	-31.113	74.000
7311.000	11.795	39.420	51.214	-22.786	74.000
9748.000	12.635	37.350	49.985	-24.015	74.000
<b>Average Detector:</b>					
--					
<b>Vertical</b>					
<b>Peak Detector:</b>					
4874.000	5.812	41.560	47.371	-26.629	74.000
7311.000	12.630	39.450	52.079	-21.921	74.000
9748.000	13.126	36.960	50.086	-23.914	74.000
<b>Average Detector:</b>					
--					

Note:

1. All Readings below 1GHz are Quasi-Peak, above 1GHz are performed with peak and/or average measurements as necessary.
2. Peak measurements: RBW = 1MHz, VBW = 3 MHz, Sweep: Auto.
3. Average measurements: RBW = 1MHz, VBW = 10 Hz, Sweep: Auto.
4. Measurement Level = Reading Level + Correct Factor.
5. Correct Factor = Antenna factor + Cable loss – Amplifier gain.
6. The average measurement was not performed when the peak measured data under the limit of average detection.
7. The emission levels of other frequencies are very lower than the limit and not show in test report.

Product : Intel® Dual Band Wireless-AC 8260  
 Test Item : Harmonic Radiated Emission Data  
 Test Site : No.3 OATS  
 Test Mode : Mode 1 SISO A: Transmit (802.11g 6Mbps) (2462 MHz)

Frequency MHz	Correct Factor dB	Reading Level dBuV	Measurement Level dBuV/m	Margin dB	Limit dBuV/m
<b>Horizontal</b>					
<b>Peak Detector:</b>					
4924.000	2.858	39.650	42.507	-31.493	74.000
7386.000	12.127	40.250	52.378	-21.622	74.000
9848.000	12.852	37.350	50.203	-23.797	74.000
<b>Average Detector:</b>					
--					
<b>Vertical</b>					
<b>Peak Detector:</b>					
4924.000	5.521	41.360	46.880	-27.120	74.000
7386.000	13.254	39.680	52.934	-21.066	74.000
9848.000	13.367	37.150	50.517	-23.483	74.000
<b>Average Detector:</b>					
--					

Note:

1. All Readings below 1GHz are Quasi-Peak, above 1GHz are performed with peak and/or average measurements as necessary.
2. Peak measurements: RBW = 1MHz, VBW = 3 MHz, Sweep: Auto.
3. Average measurements: RBW = 1MHz, VBW = 10 Hz, Sweep: Auto.
4. Measurement Level = Reading Level + Correct Factor.
5. Correct Factor = Antenna factor + Cable loss – Amplifier gain.
6. The average measurement was not performed when the peak measured data under the limit of average detection.
7. The emission levels of other frequencies are very lower than the limit and not show in test report.

Product : Intel® Dual Band Wireless-AC 8260  
 Test Item : Harmonic Radiated Emission Data  
 Test Site : No.3 OATS  
 Test Mode : Mode 1 SISO A: Transmit (802.11g 6Mbps) (2467 MHz)

Frequency MHz	Correct Factor dB	Reading Level dBuV	Measurement Level dBuV/m	Margin dB	Limit dBuV/m
<b>Horizontal</b>					
<b>Peak Detector:</b>					
4934.000	2.830	37.650	40.481	-33.519	74.000
7401.000	12.218	36.850	49.068	-24.932	74.000
9868.000	13.043	36.740	49.782	-24.218	74.000
<b>Average Detector:</b>					
--					
<b>Vertical</b>					
<b>Peak Detector:</b>					
4934.000	5.530	37.950	43.481	-30.519	74.000
7401.000	13.345	36.840	50.186	-23.814	74.000
9868.000	13.602	36.640	50.241	-23.759	74.000
<b>Average Detector:</b>					
--					

Note:

1. All Readings below 1GHz are Quasi-Peak, above 1GHz are performed with peak and/or average measurements as necessary.
2. Peak measurements: RBW = 1MHz, VBW = 3 MHz, Sweep: Auto.
3. Average measurements: RBW = 1MHz, VBW = 10 Hz, Sweep: Auto.
4. Measurement Level = Reading Level + Correct Factor.
5. Correct Factor = Antenna factor + Cable loss – Amplifier gain.
6. The average measurement was not performed when the peak measured data under the limit of average detection.
7. The emission levels of other frequencies are very lower than the limit and not show in test report.

Product : Intel® Dual Band Wireless-AC 8260  
 Test Item : Harmonic Radiated Emission Data  
 Test Site : No.3 OATS  
 Test Mode : Mode 1 SISO A: Transmit - 802.11a 6Mbps (5745 MHz)

Frequency	Correct	Reading	Measurement	Margin	Limit
MHz	Factor	Level	Level	dB	dBuV/m
	dB	dBuV	dBuV/m		

**Horizontal**

**Peak Detector:**

11490.000	17.106	35.840	52.947	-21.053	74.000
-----------	--------	--------	--------	---------	--------

**Average**

**Detector:**

--

**Vertical**

**Peak Detector:**

11490.000	18.034	35.680	53.715	-20.285	74.000
-----------	--------	--------	--------	---------	--------

**Average**

**Detector:**

--

Note:

1. All Readings below 1GHz are Quasi-Peak, above 1GHz are performed with peak and/or average measurements as necessary.
2. Peak measurements: RBW = 1MHz, VBW = 3 MHz, Sweep: Auto.
3. Average measurements: RBW = 1MHz, VBW = 10 Hz, Sweep: Auto.
4. Measurement Level = Reading Level + Correct Factor.
5. Correct Factor = Antenna factor + Cable loss –Amplifier gain.
6. The average measurement was not performed when the peak measured data under the limit of average detection.
7. The emission levels of other frequencies are very lower than the limit and not show in test report.

Product : Intel® Dual Band Wireless-AC 8260  
 Test Item : Harmonic Radiated Emission Data  
 Test Site : No.3 OATS  
 Test Mode : Mode 1 SISO A: Transmit - 802.11a 6Mbps (5785 MHz)

Frequency	Correct	Reading	Measurement	Margin	Limit
MHz	Factor	Level	Level	dB	dBuV/m
	dB	dBuV	dBuV/m		

**Horizontal**

**Peak Detector:**

11570.000	16.809	35.690	52.499	-21.501	74.000
-----------	--------	--------	--------	---------	--------

**Average**

**Detector:**

--

**Vertical**

**Peak Detector:**

11570.000	17.698	36.240	53.938	-20.062	74.000
-----------	--------	--------	--------	---------	--------

**Average**

**Detector:**

--

Note:

1. All Readings below 1GHz are Quasi-Peak, above 1GHz are performed with peak and/or average measurements as necessary.
2. Peak measurements: RBW = 1MHz, VBW = 3 MHz, Sweep: Auto.
3. Average measurements: RBW = 1MHz, VBW = 10 Hz, Sweep: Auto.
4. Measurement Level = Reading Level + Correct Factor.
5. Correct Factor = Antenna factor + Cable loss – Amplifier gain.
6. The average measurement was not performed when the peak measured data under the limit of average detection.
7. The emission levels of other frequencies are very lower than the limit and not show in test report.

Product : Intel® Dual Band Wireless-AC 8260  
Test Item : Harmonic Radiated Emission Data  
Test Site : No.3 OATS  
Test Mode : Mode 1 SISO A: Transmit - 802.11a 6Mbps (5825 MHz)

Frequency MHz	Correct Factor dB	Reading Level dBuV	Measurement Level dBuV/m	Margin dB	Limit dBuV/m
<b>Horizontal</b>					
<b>Peak Detector:</b>					
11650.000	16.158	35.770	51.928	-22.072	74.000
<b>Average Detector:</b>					
--					
<b>Vertical</b>					
<b>Peak Detector:</b>					
11650.000	17.274	35.580	52.855	-21.145	74.000
<b>Average Detector:</b>					
--					

Note:

1. All Readings below 1GHz are Quasi-Peak, above 1GHz are performed with peak and/or average measurements as necessary.
2. Peak measurements: RBW = 1MHz, VBW = 3 MHz, Sweep: Auto.
3. Average measurements: RBW = 1MHz, VBW = 10 Hz, Sweep: Auto.
4. Measurement Level = Reading Level + Correct Factor.
5. Correct Factor = Antenna factor + Cable loss –Amplifier gain.
6. The average measurement was not performed when the peak measured data under the limit of average detection.
7. The emission levels of other frequencies are very lower than the limit and not show in test report.

Product : Intel® Dual Band Wireless-AC 8260  
 Test Item : Harmonic Radiated Emission Data  
 Test Site : No.3 OATS  
 Test Mode : Mode 1 SISO A: Transmit - 802.11n-20BW\_7.2Mbps(2.4G Band) (2412MHz)

Frequency MHz	Correct Factor dB	Reading Level dBuV	Measurement Level dBuV/m	Margin dB	Limit dBuV/m
<b>Horizontal</b>					
<b>Peak Detector:</b>					
4824.000	3.261	38.620	41.881	-32.119	74.000
7236.000	10.650	39.810	50.460	-23.540	74.000
9648.000	13.337	37.540	50.876	-23.124	74.000
<b>Average Detector:</b>					
--					
<b>Vertical</b>					
<b>Peak Detector:</b>					
4824.000	6.421	40.420	46.841	-27.159	74.000
7236.000	11.495	38.450	49.945	-24.055	74.000
9648.000	13.807	37.240	51.046	-22.954	74.000
<b>Average Detector:</b>					
--					

Note:

1. All Readings below 1GHz are Quasi-Peak, above 1GHz are performed with peak and/or average measurements as necessary.
2. Peak measurements: RBW = 1MHz, VBW = 3 MHz, Sweep: Auto.
3. Average measurements: RBW = 1MHz, VBW = 10 Hz, Sweep: Auto.
4. Measurement Level = Reading Level + Correct Factor.
5. Correct Factor = Antenna factor + Cable loss – Amplifier gain.
6. The average measurement was not performed when the peak measured data under the limit of average detection.
7. The emission levels of other frequencies are very lower than the limit and not show in test report.

Product : Intel® Dual Band Wireless-AC 8260  
 Test Item : Harmonic Radiated Emission Data  
 Test Site : No.3 OATS  
 Test Mode : Mode 1 SISO A: Transmit - 802.11n-20BW\_7.2Mbps(2.4G Band) (2437 MHz)

Frequency	Correct	Reading	Measurement	Margin	Limit
MHz	Factor	Level	Level	dB	dBuV/m
	dB	dBuV	dBuV/m		

**Horizontal**

**Peak Detector:**

4874.000	3.038	38.560	41.597	-32.403	74.000
7311.000	11.795	39.640	51.434	-22.566	74.000
9748.000	12.635	36.850	49.485	-24.515	74.000

**Average**

**Detector:**

--

**Vertical**

**Peak Detector:**

4874.000	5.812	40.950	46.761	-27.239	74.000
7311.000	12.630	38.450	51.079	-22.921	74.000
9748.000	13.126	36.680	49.806	-24.194	74.000

**Average**

**Detector:**

--

Note:

1. All Readings below 1GHz are Quasi-Peak, above 1GHz are performed with peak and/or average measurements as necessary.
2. Peak measurements: RBW = 1MHz, VBW = 3 MHz, Sweep: Auto.
3. Average measurements: RBW = 1MHz, VBW = 10 Hz, Sweep: Auto.
4. Measurement Level = Reading Level + Correct Factor.
5. Correct Factor = Antenna factor + Cable loss –Amplifier gain.
6. The average measurement was not performed when the peak measured data under the limit of average detection.
7. The emission levels of other frequencies are very lower than the limit and not show in test report.



Product : Intel® Dual Band Wireless-AC 8260  
 Test Item : Harmonic Radiated Emission Data  
 Test Site : No.3 OATS  
 Test Mode : Mode 1 SISO A: Transmit - 802.11n-20BW\_7.2Mbps(2.4G Band) (2462 MHz)

Frequency MHz	Correct Factor dB	Reading Level dBuV	Measurement Level dBuV/m	Margin dB	Limit dBuV/m
<b>Horizontal</b>					
<b>Peak Detector:</b>					
4924.000	2.858	38.650	41.507	-32.493	74.000
7386.000	12.127	39.670	51.798	-22.202	74.000
9848.000	12.852	37.840	50.693	-23.307	74.000
<b>Average Detector:</b>					
--					
<b>Vertical</b>					
<b>Peak Detector:</b>					
4924.000	5.521	40.750	46.270	-27.730	74.000
7386.000	13.254	38.640	51.894	-22.106	74.000
9848.000	13.367	36.420	49.787	-24.213	74.000
<b>Average Detector:</b>					
--					

Note:

1. All Readings below 1GHz are Quasi-Peak, above 1GHz are performed with peak and/or average measurements as necessary.
2. Peak measurements: RBW = 1MHz, VBW = 3 MHz, Sweep: Auto.
3. Average measurements: RBW = 1MHz, VBW = 10 Hz, Sweep: Auto.
4. Measurement Level = Reading Level + Correct Factor.
5. Correct Factor = Antenna factor + Cable loss – Amplifier gain.
6. The average measurement was not performed when the peak measured data under the limit of average detection.
7. The emission levels of other frequencies are very lower than the limit and not show in test report.

Product : Intel® Dual Band Wireless-AC 8260  
 Test Item : Harmonic Radiated Emission Data  
 Test Site : No.3 OATS  
 Test Mode : Mode 1 SISO A: Transmit - 802.11n-20BW\_7.2Mbps(2.4G Band) (2467 MHz)

Frequency MHz	Correct Factor dB	Reading Level dBuV	Measurement Level dBuV/m	Margin dB	Limit dBuV/m
<b>Horizontal</b>					
<b>Peak Detector:</b>					
4934.000	2.830	37.450	40.281	-33.719	74.000
7401.000	12.218	36.560	48.778	-25.222	74.000
9868.000	13.043	36.850	49.892	-24.108	74.000
<b>Average Detector:</b>					
--					
<b>Vertical</b>					
<b>Peak Detector:</b>					
4934.000	5.530	37.350	42.881	-31.119	74.000
7401.000	13.345	36.920	50.266	-23.734	74.000
9868.000	13.602	36.870	50.471	-23.529	74.000
<b>Average Detector:</b>					
--					

Note:

1. All Readings below 1GHz are Quasi-Peak, above 1GHz are performed with peak and/or average measurements as necessary.
2. Peak measurements: RBW = 1MHz, VBW = 3 MHz, Sweep: Auto.
3. Average measurements: RBW = 1MHz, VBW = 10 Hz, Sweep: Auto.
4. Measurement Level = Reading Level + Correct Factor.
5. Correct Factor = Antenna factor + Cable loss – Amplifier gain.
6. The average measurement was not performed when the peak measured data under the limit of average detection.
7. The emission levels of other frequencies are very lower than the limit and not show in test report.

Product : Intel® Dual Band Wireless-AC 8260  
 Test Item : Harmonic Radiated Emission Data  
 Test Site : No.3 OATS  
 Test Mode : Mode 1 SISO A: Transmit - 802.11n-40BW\_15Mbps(2.4G Band) (2422MHz)

Frequency MHz	Correct Factor dB	Reading Level dBuV	Measurement Level dBuV/m	Margin dB	Limit dBuV/m
<b>Horizontal</b>					
<b>Peak Detector:</b>					
4844.000	3.171	38.640	41.811	-32.189	74.000
7266.000	11.162	37.260	48.422	-25.578	74.000
9688.000	12.964	36.730	49.695	-24.305	74.000
<b>Average Detector:</b>					
--					
<b>Vertical</b>					
<b>Peak Detector:</b>					
4844.000	6.178	39.050	45.228	-28.772	74.000
7266.000	11.982	36.820	48.802	-25.198	74.000
9688.000	13.507	36.840	50.348	-23.652	74.000
<b>Average Detector:</b>					
--					

Note:

1. All Readings below 1GHz are Quasi-Peak, above 1GHz are performed with peak and/or average measurements as necessary.
2. Peak measurements: RBW = 1MHz, VBW = 3 MHz, Sweep: Auto.
3. Average measurements: RBW = 1MHz, VBW = 10 Hz, Sweep: Auto.
4. Measurement Level = Reading Level + Correct Factor.
5. Correct Factor = Antenna factor + Cable loss – Amplifier gain.
6. The average measurement was not performed when the peak measured data under the limit of average detection.
7. The emission levels of other frequencies are very lower than the limit and not show in test report.

Product : Intel® Dual Band Wireless-AC 8260  
 Test Item : Harmonic Radiated Emission Data  
 Test Site : No.3 OATS  
 Test Mode : Mode 1 SISO A: Transmit - 802.11n-40BW\_15Mbps(2.4G Band) (2437 MHz)

Frequency	Correct	Reading	Measurement	Margin	Limit
MHz	Factor	Level	Level	dB	dBuV/m
	dB	dBuV	dBuV/m		

**Horizontal**

**Peak Detector:**

4874.000	3.038	38.540	41.577	-32.423	74.000
7311.000	11.795	37.290	49.084	-24.916	74.000
9748.000	12.635	36.840	49.475	-24.525	74.000

**Average**

**Detector:**

--

**Vertical**

**Peak Detector:**

4874.000	5.812	38.950	44.761	-29.239	74.000
7311.000	12.630	36.810	49.439	-24.561	74.000
9748.000	13.126	36.450	49.576	-24.424	74.000

**Average**

**Detector:**

--

Note:

1. All Readings below 1GHz are Quasi-Peak, above 1GHz are performed with peak and/or average measurements as necessary.
2. Peak measurements: RBW = 1MHz, VBW = 3 MHz, Sweep: Auto.
3. Average measurements: RBW = 1MHz, VBW = 10 Hz, Sweep: Auto.
4. Measurement Level = Reading Level + Correct Factor.
5. Correct Factor = Antenna factor + Cable loss – Amplifier gain.
6. The average measurement was not performed when the peak measured data under the limit of average detection.
7. The emission levels of other frequencies are very lower than the limit and not show in test report.

Product : Intel® Dual Band Wireless-AC 8260  
 Test Item : Harmonic Radiated Emission Data  
 Test Site : No.3 OATS  
 Test Mode : Mode 1 SISO A: Transmit - 802.11n-40BW\_15Mbps(2.4G Band) (2452 MHz)

Frequency MHz	Correct Factor dB	Reading Level dBuV	Measurement Level dBuV/m	Margin dB	Limit dBuV/m
<b>Horizontal</b>					
<b>Peak Detector:</b>					
4904.000	2.914	39.040	41.955	-32.045	74.000
7356.000	11.995	37.680	49.674	-24.326	74.000
9808.000	12.475	37.240	49.715	-24.285	74.000
<b>Average Detector:</b>					
--					
<b>Vertical</b>					
<b>Peak Detector:</b>					
4904.000	5.530	40.840	46.371	-27.629	74.000
7356.000	13.005	38.670	51.674	-22.326	74.000
9808.000	12.901	36.460	49.361	-24.639	74.000
<b>Average Detector:</b>					
--					

Note:

1. All Readings below 1GHz are Quasi-Peak, above 1GHz are performed with peak and/or average measurements as necessary.
2. Peak measurements: RBW = 1MHz, VBW = 3 MHz, Sweep: Auto.
3. Average measurements: RBW = 1MHz, VBW = 10 Hz, Sweep: Auto.
4. Measurement Level = Reading Level + Correct Factor.
5. Correct Factor = Antenna factor + Cable loss – Amplifier gain.
6. The average measurement was not performed when the peak measured data under the limit of average detection.
7. The emission levels of other frequencies are very lower than the limit and not show in test report.

Product : Intel® Dual Band Wireless-AC 8260  
 Test Item : Harmonic Radiated Emission Data  
 Test Site : No.3 OATS  
 Test Mode : Mode 1 SISO A: Transmit - 802.11n-40BW\_15Mbps(2.4G Band) (2457 MHz)

Frequency MHz	Correct Factor dB	Reading Level dBuV	Measurement Level dBuV/m	Margin dB	Limit dBuV/m
<b>Horizontal</b>					
<b>Peak Detector:</b>					
4914.000	2.883	37.820	40.703	-33.297	74.000
7371.000	12.062	36.360	48.422	-25.578	74.000
9828.000	12.664	36.430	49.094	-24.906	74.000
<b>Average Detector:</b>					
--					
<b>Vertical</b>					
<b>Peak Detector:</b>					
4914.000	5.508	37.650	43.158	-30.842	74.000
7371.000	13.130	36.690	49.820	-24.180	74.000
9828.000	13.135	36.820	49.955	-24.045	74.000
<b>Average Detector:</b>					
--					

Note:

1. All Readings below 1GHz are Quasi-Peak, above 1GHz are performed with peak and/or average measurements as necessary.
2. Peak measurements: RBW = 1MHz, VBW = 3 MHz, Sweep: Auto.
3. Average measurements: RBW = 1MHz, VBW = 10 Hz, Sweep: Auto.
4. Measurement Level = Reading Level + Correct Factor.
5. Correct Factor = Antenna factor + Cable loss –Amplifier gain.
6. The average measurement was not performed when the peak measured data under the limit of average detection.
7. The emission levels of other frequencies are very lower than the limit and not show in test report.

Product : Intel® Dual Band Wireless-AC 8260  
 Test Item : Harmonic Radiated Emission Data  
 Test Site : No.3 OATS  
 Test Mode : Mode 1 SISO A: Transmit - 802.11n-20BW\_7.2Mbps(5G Band) (5745MHz)

Frequency MHz	Correct Factor dB	Reading Level dBuV	Measurement Level dBuV/m	Margin dB	Limit dBuV/m
<b>Horizontal</b>					
<b>Peak Detector:</b>					
11490.000	17.106	35.270	52.377	-21.623	74.000
<b>Average Detector:</b>					
--					
<b>Vertical</b>					
<b>Peak Detector:</b>					
11490.000	18.034	35.420	53.455	-20.545	74.000
<b>Average Detector:</b>					
--					

Note:

1. All Readings below 1GHz are Quasi-Peak, above 1GHz are performed with peak and/or average measurements as necessary.
2. Peak measurements: RBW = 1MHz, VBW = 3 MHz, Sweep: Auto.
3. Average measurements: RBW = 1MHz, VBW = 10 Hz, Sweep: Auto.
4. Measurement Level = Reading Level + Correct Factor.
5. Correct Factor = Antenna factor + Cable loss –Amplifier gain.
6. The average measurement was not performed when the peak measured data under the limit of average detection.
7. The emission levels of other frequencies are very lower than the limit and not show in test report.

Product : Intel® Dual Band Wireless-AC 8260  
 Test Item : Harmonic Radiated Emission Data  
 Test Site : No.3 OATS  
 Test Mode : Mode 1 SISO A: Transmit - 802.11n-20BW\_7.2Mbps(5G Band) (5785 MHz)

Frequency MHz	Correct Factor dB	Reading Level dBuV	Measurement Level dBuV/m	Margin dB	Limit dBuV/m
<b>Horizontal</b>					
<b>Peak Detector:</b>					
11570.000	16.809	35.620	52.429	-21.571	74.000
<b>Average Detector:</b>					
--					
<b>Vertical</b>					
<b>Peak Detector:</b>					
11570.000	17.698	35.810	53.508	-20.492	74.000
<b>Average Detector:</b>					
--					

Note:

1. All Readings below 1GHz are Quasi-Peak, above 1GHz are performed with peak and/or average measurements as necessary.
2. Peak measurements: RBW = 1MHz, VBW = 3 MHz, Sweep: Auto.
3. Average measurements: RBW = 1MHz, VBW = 10 Hz, Sweep: Auto.
4. Measurement Level = Reading Level + Correct Factor.
5. Correct Factor = Antenna factor + Cable loss –Amplifier gain.
6. The average measurement was not performed when the peak measured data under the limit of average detection.
7. The emission levels of other frequencies are very lower than the limit and not show in test report.



Product : Intel® Dual Band Wireless-AC 8260  
Test Item : Harmonic Radiated Emission Data  
Test Site : No.3 OATS  
Test Mode : Mode 1 SISO A: Transmit - 802.11n-20BW\_7.2Mbps(5G Band) (5825 MHz)

Frequency MHz	Correct Factor dB	Reading Level dBuV	Measurement Level dBuV/m	Margin dB	Limit dBuV/m
<b>Horizontal</b>					
<b>Peak Detector:</b>					
11650.000	16.158	35.620	51.778	-22.222	74.000
<b>Average Detector:</b>					
--					
<b>Vertical</b>					
<b>Peak Detector:</b>					
11650.000	17.274	35.720	52.995	-21.005	74.000
<b>Average Detector:</b>					
--					

Note:

1. All Readings below 1GHz are Quasi-Peak, above 1GHz are performed with peak and/or average measurements as necessary.
2. Peak measurements: RBW = 1MHz, VBW = 3 MHz, Sweep: Auto.
3. Average measurements: RBW = 1MHz, VBW = 10 Hz, Sweep: Auto.
4. Measurement Level = Reading Level + Correct Factor.
5. Correct Factor = Antenna factor + Cable loss –Amplifier gain.
6. The average measurement was not performed when the peak measured data under the limit of average detection.
7. The emission levels of other frequencies are very lower than the limit and not show in test report.

Product : Intel® Dual Band Wireless-AC 8260  
 Test Item : Harmonic Radiated Emission Data  
 Test Site : No.3 OATS  
 Test Mode : Mode 1 SISO A: Transmit - 802.11n-40BW\_15Mbps(5G Band) (5755MHz)

Frequency MHz	Correct Factor dB	Reading Level dBuV	Measurement Level dBuV/m	Margin dB	Limit dBuV/m
<b>Horizontal</b>					
<b>Peak Detector:</b>					
11510.000	17.124	35.750	52.874	-21.126	74.000
<b>Average Detector:</b>					
--					
<b>Vertical</b>					
<b>Peak Detector:</b>					
11510.000	18.081	35.720	53.801	-20.199	74.000
<b>Average Detector:</b>					
--					

Note:

1. All Readings below 1GHz are Quasi-Peak, above 1GHz are performed with peak and/or average measurements as necessary.
2. Peak measurements: RBW = 1MHz, VBW = 3 MHz, Sweep: Auto.
3. Average measurements: RBW = 1MHz, VBW = 10 Hz, Sweep: Auto.
4. Measurement Level = Reading Level + Correct Factor.
5. Correct Factor = Antenna factor + Cable loss – Amplifier gain.
6. The average measurement was not performed when the peak measured data under the limit of average detection.
7. The emission levels of other frequencies are very lower than the limit and not show in test report.

Product : Intel® Dual Band Wireless-AC 8260  
 Test Item : Harmonic Radiated Emission Data  
 Test Site : No.3 OATS  
 Test Mode : Mode 1 SISO A: Transmit - 802.11n-40BW\_15Mbps(5G Band) (5795 MHz)

Frequency MHz	Correct Factor dB	Reading Level dBuV	Measurement Level dBuV/m	Margin dB	Limit dBuV/m
<b>Horizontal</b>					
<b>Peak Detector:</b>					
11590.000	16.701	35.940	52.640	-21.360	74.000
<b>Average Detector:</b>					
--					
<b>Vertical</b>					
<b>Peak Detector:</b>					
11590.000	17.567	35.640	53.206	-20.794	74.000
<b>Average Detector:</b>					
--					

Note:

1. All Readings below 1GHz are Quasi-Peak, above 1GHz are performed with peak and/or average measurements as necessary.
2. Peak measurements: RBW = 1MHz, VBW = 3 MHz, Sweep: Auto.
3. Average measurements: RBW = 1MHz, VBW = 10 Hz, Sweep: Auto.
4. Measurement Level = Reading Level + Correct Factor.
5. Correct Factor = Antenna factor + Cable loss – Amplifier gain.
6. The average measurement was not performed when the peak measured data under the limit of average detection.
7. The emission levels of other frequencies are very lower than the limit and not show in test report.

Product : Intel® Dual Band Wireless-AC 8260  
Test Item : Harmonic Radiated Emission Data  
Test Site : No.3 OATS  
Test Mode : Mode 1 SISO A: Transmit - 802.11ac-80BW\_32.5Mbps(5G Band) (5775 MHz)

Frequency MHz	Correct Factor dB	Reading Level dBuV	Measurement Level dBuV/m	Margin dB	Limit dBuV/m
<b>Horizontal</b>					
<b>Peak Detector:</b>					
11530.000	17.018	36.270	53.289	-20.711	74.000
<b>Average Detector:</b>					
--					
<b>Vertical</b>					
<b>Peak Detector:</b>					
11530.000	17.952	35.480	53.433	-20.567	74.000
<b>Average Detector:</b>					
--					

Note:

1. All Readings below 1GHz are Quasi-Peak, above 1GHz are performed with peak and/or average measurements as necessary.
2. Peak measurements: RBW = 1MHz, VBW = 3 MHz, Sweep: Auto.
3. Average measurements: RBW = 1MHz, VBW = 10 Hz, Sweep: Auto.
4. Measurement Level = Reading Level + Correct Factor.
5. Correct Factor = Antenna factor + Cable loss –Amplifier gain.
6. The average measurement was not performed when the peak measured data under the limit of average detection.
7. The emission levels of other frequencies are very lower than the limit and not show in test report.

Product : Intel® Dual Band Wireless-AC 8260  
 Test Item : Harmonic Radiated Emission Data  
 Test Site : No.3 OATS  
 Test Mode : Mode 2 SISO B: Transmit (802.11b 1Mbps) (2412MHz)

Frequency MHz	Correct Factor dB	Reading Level dBuV	Measurement Level dBuV/m	Margin dB	Limit dBuV/m
<b>Horizontal</b>					
<b>Peak Detector:</b>					
4824.000	3.261	39.280	42.541	-31.459	74.000
7236.000	10.650	37.060	47.710	-26.290	74.000
9648.000	13.337	37.180	50.516	-23.484	74.000
<b>Average Detector:</b>					
--					
<b>Vertical</b>					
<b>Peak Detector:</b>					
4824.000	6.421	42.260	48.681	-25.319	74.000
7236.000	11.495	35.890	47.385	-26.615	74.000
9648.000	13.807	37.250	51.056	-22.944	74.000
<b>Average Detector:</b>					
--					

Note:

1. All Readings below 1GHz are Quasi-Peak, above 1GHz are performed with peak and/or average measurements as necessary.
2. Peak measurements: RBW = 1MHz, VBW = 3 MHz, Sweep: Auto.
3. Average measurements: RBW = 1MHz, VBW = 10 Hz, Sweep: Auto.
4. Measurement Level = Reading Level + Correct Factor.
5. Correct Factor = Antenna factor + Cable loss – Amplifier gain.
6. The average measurement was not performed when the peak measured data under the limit of average detection.
7. The emission levels of other frequencies are very lower than the limit and not show in test report.

Product : Intel® Dual Band Wireless-AC 8260  
 Test Item : Harmonic Radiated Emission Data  
 Test Site : No.3 OATS  
 Test Mode : Mode 2 SISO B: Transmit (802.11b 1Mbps) (2437 MHz)

Frequency MHz	Correct Factor dB	Reading Level dBuV	Measurement Level dBuV/m	Margin dB	Limit dBuV/m
<b>Horizontal</b>					
<b>Peak Detector:</b>					
4874.000	3.038	39.480	42.517	-31.483	74.000
7311.000	11.795	36.670	48.464	-25.536	74.000
9748.000	12.635	37.340	49.975	-24.025	74.000
<b>Average Detector:</b>					
--					
<b>Vertical</b>					
<b>Peak Detector:</b>					
4874.000	5.812	42.030	47.841	-26.159	74.000
7311.000	12.630	37.640	50.269	-23.731	74.000
9748.000	13.126	36.970	50.096	-23.904	74.000
<b>Average Detector:</b>					
--					

Note:

1. All Readings below 1GHz are Quasi-Peak, above 1GHz are performed with peak and/or average measurements as necessary.
2. Peak measurements: RBW = 1MHz, VBW = 3 MHz, Sweep: Auto.
3. Average measurements: RBW = 1MHz, VBW = 10 Hz, Sweep: Auto.
4. Measurement Level = Reading Level + Correct Factor.
5. Correct Factor = Antenna factor + Cable loss – Amplifier gain.
6. The average measurement was not performed when the peak measured data under the limit of average detection.
7. The emission levels of other frequencies are very lower than the limit and not show in test report.

Product : Intel® Dual Band Wireless-AC 8260  
 Test Item : Harmonic Radiated Emission Data  
 Test Site : No.3 OATS  
 Test Mode : Mode 2 SISO B: Transmit (802.11b 1Mbps) (2462 MHz)

Frequency MHz	Correct Factor dB	Reading Level dBuV	Measurement Level dBuV/m	Margin dB	Limit dBuV/m
<b>Horizontal</b>					
<b>Peak Detector:</b>					
4924.000	2.858	39.870	42.727	-31.273	74.000
7386.000	12.127	37.080	49.208	-24.792	74.000
9848.000	12.852	36.590	49.443	-24.557	74.000
<b>Average Detector:</b>					
--					
<b>Vertical</b>					
<b>Peak Detector:</b>					
4924.000	5.521	41.640	47.160	-26.840	74.000
7386.000	13.254	37.510	50.764	-23.236	74.000
9848.000	13.367	37.320	50.687	-23.313	74.000
<b>Average Detector:</b>					
--					

Note:

1. All Readings below 1GHz are Quasi-Peak, above 1GHz are performed with peak and/or average measurements as necessary.
2. Peak measurements: RBW = 1MHz, VBW = 3 MHz, Sweep: Auto.
3. Average measurements: RBW = 1MHz, VBW = 10 Hz, Sweep: Auto.
4. Measurement Level = Reading Level + Correct Factor.
5. Correct Factor = Antenna factor + Cable loss – Amplifier gain.
6. The average measurement was not performed when the peak measured data under the limit of average detection.
7. The emission levels of other frequencies are very lower than the limit and not show in test report.

Product : Intel® Dual Band Wireless-AC 8260  
 Test Item : Harmonic Radiated Emission Data  
 Test Site : No.3 OATS  
 Test Mode : Mode 2 SISO B: Transmit (802.11b 1Mbps) (2467 MHz)

Frequency MHz	Correct Factor dB	Reading Level dBuV	Measurement Level dBuV/m	Margin dB	Limit dBuV/m
<b>Horizontal</b>					
<b>Peak Detector:</b>					
4934.000	2.830	37.840	40.671	-33.329	74.000
7401.000	12.218	36.980	49.198	-24.802	74.000
9868.000	13.043	36.380	49.422	-24.578	74.000
<b>Average Detector:</b>					
--					
<b>Vertical</b>					
<b>Peak Detector:</b>					
4934.000	5.530	37.460	42.991	-31.009	74.000
7401.000	13.345	36.650	49.996	-24.004	74.000
9868.000	13.602	36.540	50.141	-23.859	74.000
<b>Average Detector:</b>					
--					

Note:

1. All Readings below 1GHz are Quasi-Peak, above 1GHz are performed with peak and/or average measurements as necessary.
2. Peak measurements: RBW = 1MHz, VBW = 3 MHz, Sweep: Auto.
3. Average measurements: RBW = 1MHz, VBW = 10 Hz, Sweep: Auto.
4. Measurement Level = Reading Level + Correct Factor.
5. Correct Factor = Antenna factor + Cable loss – Amplifier gain.
6. The average measurement was not performed when the peak measured data under the limit of average detection.
7. The emission levels of other frequencies are very lower than the limit and not show in test report.



Product : Intel® Dual Band Wireless-AC 8260  
Test Item : Harmonic Radiated Emission Data  
Test Site : No.3 OATS  
Test Mode : Mode 2 SISO B: Transmit (802.11g 6Mbps) (2412MHz)

Frequency MHz	Correct Factor dB	Reading Level dBuV	Measurement Level dBuV/m	Margin dB	Limit dBuV/m
<b>Horizontal</b>					
<b>Peak Detector:</b>					
4824.000	3.261	39.620	42.881	-31.119	74.000
7236.000	10.650	39.310	49.960	-24.040	74.000
9648.000	13.337	37.140	50.476	-23.524	74.000
<b>Average Detector:</b>					
--					
<b>Vertical</b>					
<b>Peak Detector:</b>					
4824.000	6.421	40.990	47.411	-26.589	74.000
7236.000	11.495	38.840	50.335	-23.665	74.000
9648.000	13.807	36.710	50.516	-23.484	74.000
<b>Average Detector:</b>					
--					

Note:

1. All Readings below 1GHz are Quasi-Peak, above 1GHz are performed with peak and/or average measurements as necessary.
2. Peak measurements: RBW = 1MHz, VBW = 3 MHz, Sweep: Auto.
3. Average measurements: RBW = 1MHz, VBW = 10 Hz, Sweep: Auto.
4. Measurement Level = Reading Level + Correct Factor.
5. Correct Factor = Antenna factor + Cable loss –Amplifier gain.
6. The average measurement was not performed when the peak measured data under the limit of average detection.
7. The emission levels of other frequencies are very lower than the limit and not show in test report.

Product : Intel® Dual Band Wireless-AC 8260  
 Test Item : Harmonic Radiated Emission Data  
 Test Site : No.3 OATS  
 Test Mode : Mode 2 SISO B: Transmit (802.11g 6Mbps) (2437 MHz)

Frequency MHz	Correct Factor dB	Reading Level dBuV	Measurement Level dBuV/m	Margin dB	Limit dBuV/m
<b>Horizontal</b>					
<b>Peak Detector:</b>					
4874.000	3.038	39.660	42.697	-31.303	74.000
7311.000	11.795	39.250	51.044	-22.956	74.000
9748.000	12.635	37.270	49.905	-24.095	74.000
<b>Average Detector:</b>					
--					
<b>Vertical</b>					
<b>Peak Detector:</b>					
4874.000	5.812	41.190	47.001	-26.999	74.000
7311.000	12.630	39.240	51.869	-22.131	74.000
9748.000	13.126	36.750	49.876	-24.124	74.000
<b>Average Detector:</b>					
--					

Note:

1. All Readings below 1GHz are Quasi-Peak, above 1GHz are performed with peak and/or average measurements as necessary.
2. Peak measurements: RBW = 1MHz, VBW = 3 MHz, Sweep: Auto.
3. Average measurements: RBW = 1MHz, VBW = 10 Hz, Sweep: Auto.
4. Measurement Level = Reading Level + Correct Factor.
5. Correct Factor = Antenna factor + Cable loss –Amplifier gain.
6. The average measurement was not performed when the peak measured data under the limit of average detection.
7. The emission levels of other frequencies are very lower than the limit and not show in test report.

Product : Intel® Dual Band Wireless-AC 8260  
 Test Item : Harmonic Radiated Emission Data  
 Test Site : No.3 OATS  
 Test Mode : Mode 2 SISO B: Transmit (802.11g 6Mbps) (2462 MHz)

Frequency MHz	Correct Factor dB	Reading Level dBuV	Measurement Level dBuV/m	Margin dB	Limit dBuV/m
<b>Horizontal</b>					
<b>Peak Detector:</b>					
4924.000	2.858	39.440	42.297	-31.703	74.000
7386.000	12.127	40.060	52.188	-21.812	74.000
9848.000	12.852	37.110	49.963	-24.037	74.000
<b>Average Detector:</b>					
--					
<b>Vertical</b>					
<b>Peak Detector:</b>					
4924.000	5.521	41.090	46.610	-27.390	74.000
7386.000	13.254	39.580	52.834	-21.166	74.000
9848.000	13.367	36.940	50.307	-23.693	74.000
<b>Average Detector:</b>					
--					

Note:

1. All Readings below 1GHz are Quasi-Peak, above 1GHz are performed with peak and/or average measurements as necessary.
2. Peak measurements: RBW = 1MHz, VBW = 3 MHz, Sweep: Auto.
3. Average measurements: RBW = 1MHz, VBW = 10 Hz, Sweep: Auto.
4. Measurement Level = Reading Level + Correct Factor.
5. Correct Factor = Antenna factor + Cable loss – Amplifier gain.
6. The average measurement was not performed when the peak measured data under the limit of average detection.
7. The emission levels of other frequencies are very lower than the limit and not show in test report.

Product : Intel® Dual Band Wireless-AC 8260  
 Test Item : Harmonic Radiated Emission Data  
 Test Site : No.3 OATS  
 Test Mode : Mode 2 SISO B: Transmit (802.11g 6Mbps) (2467 MHz)

Frequency MHz	Correct Factor dB	Reading Level dBuV	Measurement Level dBuV/m	Margin dB	Limit dBuV/m
<b>Horizontal</b>					
<b>Peak Detector:</b>					
4934.000	2.830	37.450	40.281	-33.719	74.000
7401.000	12.218	36.680	48.898	-25.102	74.000
9868.000	13.043	36.540	49.582	-24.418	74.000
<b>Average Detector:</b>					
--					
<b>Vertical</b>					
<b>Peak Detector:</b>					
4934.000	5.530	38.050	43.581	-30.419	74.000
7401.000	13.345	36.950	50.296	-23.704	74.000
9868.000	13.602	36.870	50.471	-23.529	74.000
<b>Average Detector:</b>					
--					

Note:

1. All Readings below 1GHz are Quasi-Peak, above 1GHz are performed with peak and/or average measurements as necessary.
2. Peak measurements: RBW = 1MHz, VBW = 3 MHz, Sweep: Auto.
3. Average measurements: RBW = 1MHz, VBW = 10 Hz, Sweep: Auto.
4. Measurement Level = Reading Level + Correct Factor.
5. Correct Factor = Antenna factor + Cable loss – Amplifier gain.
6. The average measurement was not performed when the peak measured data under the limit of average detection.
7. The emission levels of other frequencies are very lower than the limit and not show in test report.

Product : Intel® Dual Band Wireless-AC 8260  
 Test Item : Harmonic Radiated Emission Data  
 Test Site : No.3 OATS  
 Test Mode : Mode 2 SISO B: Transmit - 802.11a 6Mbps (5745 MHz)

Frequency	Correct	Reading	Measurement	Margin	Limit
MHz	Factor	Level	Level	dB	dBuV/m
	dB	dBuV	dBuV/m		

**Horizontal**

**Peak Detector:**

11490.000	17.106	35.610	52.717	-21.283	74.000
-----------	--------	--------	--------	---------	--------

**Average**

**Detector:**

--

**Vertical**

**Peak Detector:**

11490.000	18.034	35.550	53.585	-20.415	74.000
-----------	--------	--------	--------	---------	--------

**Average**

**Detector:**

--

Note:

1. All Readings below 1GHz are Quasi-Peak, above 1GHz are performed with peak and/or average measurements as necessary.
2. Peak measurements: RBW = 1MHz, VBW = 3 MHz, Sweep: Auto.
3. Average measurements: RBW = 1MHz, VBW = 10 Hz, Sweep: Auto.
4. Measurement Level = Reading Level + Correct Factor.
5. Correct Factor = Antenna factor + Cable loss – Amplifier gain.
6. The average measurement was not performed when the peak measured data under the limit of average detection.
7. The emission levels of other frequencies are very lower than the limit and not show in test report.

Product : Intel® Dual Band Wireless-AC 8260  
Test Item : Harmonic Radiated Emission Data  
Test Site : No.3 OATS  
Test Mode : Mode 2 SISO B: Transmit - 802.11a 6Mbps (5785 MHz)

Frequency	Correct	Reading	Measurement	Margin	Limit
MHz	Factor	Level	Level	dB	dBuV/m
	dB	dBuV	dBuV/m		

**Horizontal**

**Peak Detector:**

11570.000	16.809	35.490	52.299	-21.701	74.000
-----------	--------	--------	--------	---------	--------

**Average**

**Detector:**

--

**Vertical**

**Peak Detector:**

11570.000	17.698	36.120	53.818	-20.182	74.000
-----------	--------	--------	--------	---------	--------

**Average**

**Detector:**

--

Note:

1. All Readings below 1GHz are Quasi-Peak, above 1GHz are performed with peak and/or average measurements as necessary.
2. Peak measurements: RBW = 1MHz, VBW = 3 MHz, Sweep: Auto.
3. Average measurements: RBW = 1MHz, VBW = 10 Hz, Sweep: Auto.
4. Measurement Level = Reading Level + Correct Factor.
5. Correct Factor = Antenna factor + Cable loss –Amplifier gain.
6. The average measurement was not performed when the peak measured data under the limit of average detection.
7. The emission levels of other frequencies are very lower than the limit and not show in test report.

Product : Intel® Dual Band Wireless-AC 8260  
 Test Item : Harmonic Radiated Emission Data  
 Test Site : No.3 OATS  
 Test Mode : Mode 2 SISO B: Transmit - 802.11a 6Mbps (5825 MHz)

Frequency MHz	Correct Factor dB	Reading Level dBuV	Measurement Level dBuV/m	Margin dB	Limit dBuV/m
<b>Horizontal</b>					
<b>Peak Detector:</b>					
11650.000	16.158	35.670	51.828	-22.172	74.000
<b>Average Detector:</b>					
--					
<b>Vertical</b>					
<b>Peak Detector:</b>					
11650.000	17.274	35.430	52.705	-21.295	74.000
<b>Average Detector:</b>					
--					

Note:

1. All Readings below 1GHz are Quasi-Peak, above 1GHz are performed with peak and/or average measurements as necessary.
2. Peak measurements: RBW = 1MHz, VBW = 3 MHz, Sweep: Auto.
3. Average measurements: RBW = 1MHz, VBW = 10 Hz, Sweep: Auto.
4. Measurement Level = Reading Level + Correct Factor.
5. Correct Factor = Antenna factor + Cable loss –Amplifier gain.
6. The average measurement was not performed when the peak measured data under the limit of average detection.
7. The emission levels of other frequencies are very lower than the limit and not show in test report.

Product : Intel® Dual Band Wireless-AC 8260  
 Test Item : Harmonic Radiated Emission Data  
 Test Site : No.3 OATS  
 Test Mode : Mode 2 SISO B: Transmit - 802.11n-20BW\_7.2Mbps(2.4G Band) (2412MHz)

Frequency MHz	Correct Factor dB	Reading Level dBuV	Measurement Level dBuV/m	Margin dB	Limit dBuV/m
<b>Horizontal</b>					
<b>Peak Detector:</b>					
4824.000	3.261	38.510	41.771	-32.229	74.000
7236.000	10.650	39.640	50.290	-23.710	74.000
9648.000	13.337	37.320	50.656	-23.344	74.000
<b>Average Detector:</b>					
--					
<b>Vertical</b>					
<b>Peak Detector:</b>					
4824.000	6.421	40.210	46.631	-27.369	74.000
7236.000	11.495	38.240	49.735	-24.265	74.000
9648.000	13.807	37.090	50.896	-23.104	74.000
<b>Average Detector:</b>					
--					

Note:

1. All Readings below 1GHz are Quasi-Peak, above 1GHz are performed with peak and/or average measurements as necessary.
2. Peak measurements: RBW = 1MHz, VBW = 3 MHz, Sweep: Auto.
3. Average measurements: RBW = 1MHz, VBW = 10 Hz, Sweep: Auto.
4. Measurement Level = Reading Level + Correct Factor.
5. Correct Factor = Antenna factor + Cable loss – Amplifier gain.
6. The average measurement was not performed when the peak measured data under the limit of average detection.
7. The emission levels of other frequencies are very lower than the limit and not show in test report.



Product : Intel® Dual Band Wireless-AC 8260  
 Test Item : Harmonic Radiated Emission Data  
 Test Site : No.3 OATS  
 Test Mode : Mode 2 SISO B: Transmit - 802.11n-20BW\_7.2Mbps(2.4G Band) (2437 MHz)

Frequency MHz	Correct Factor dB	Reading Level dBuV	Measurement Level dBuV/m	Margin dB	Limit dBuV/m
------------------	-------------------------	--------------------------	--------------------------------	--------------	-----------------

**Horizontal**

**Peak Detector:**

4874.000	3.038	38.480	41.517	-32.483	74.000
7311.000	11.795	39.470	51.264	-22.736	74.000
9748.000	12.635	36.750	49.385	-24.615	74.000

**Average  
Detector:**

--

**Vertical**

**Peak Detector:**

4874.000	5.812	40.660	46.471	-27.529	74.000
7311.000	12.630	38.150	50.779	-23.221	74.000
9748.000	13.126	36.470	49.596	-24.404	74.000

**Average  
Detector:**

--

Note:

1. All Readings below 1GHz are Quasi-Peak, above 1GHz are performed with peak and/or average measurements as necessary.
2. Peak measurements: RBW = 1MHz, VBW = 3 MHz, Sweep: Auto.
3. Average measurements: RBW = 1MHz, VBW = 10 Hz, Sweep: Auto.
4. Measurement Level = Reading Level + Correct Factor.
5. Correct Factor = Antenna factor + Cable loss –Amplifier gain.
6. The average measurement was not performed when the peak measured data under the limit of average detection.
7. The emission levels of other frequencies are very lower than the limit and not show in test report.

Product : Intel® Dual Band Wireless-AC 8260  
 Test Item : Harmonic Radiated Emission Data  
 Test Site : No.3 OATS  
 Test Mode : Mode 2 SISO B: Transmit - 802.11n-20BW\_7.2Mbps(2.4G Band) (2462 MHz)

Frequency MHz	Correct Factor dB	Reading Level dBuV	Measurement Level dBuV/m	Margin dB	Limit dBuV/m
<b>Horizontal</b>					
<b>Peak Detector:</b>					
4924.000	2.858	38.380	41.237	-32.763	74.000
7386.000	12.127	39.480	51.608	-22.392	74.000
9848.000	12.852	37.590	50.443	-23.557	74.000
<b>Average Detector:</b>					
--					
<b>Vertical</b>					
<b>Peak Detector:</b>					
4924.000	5.521	40.580	46.100	-27.900	74.000
7386.000	13.254	38.510	51.764	-22.236	74.000
9848.000	13.367	36.280	49.647	-24.353	74.000
<b>Average Detector:</b>					
--					

Note:

1. All Readings below 1GHz are Quasi-Peak, above 1GHz are performed with peak and/or average measurements as necessary.
2. Peak measurements: RBW = 1MHz, VBW = 3 MHz, Sweep: Auto.
3. Average measurements: RBW = 1MHz, VBW = 10 Hz, Sweep: Auto.
4. Measurement Level = Reading Level + Correct Factor.
5. Correct Factor = Antenna factor + Cable loss –Amplifier gain.
6. The average measurement was not performed when the peak measured data under the limit of average detection.
7. The emission levels of other frequencies are very lower than the limit and not show in test report.

Product : Intel® Dual Band Wireless-AC 8260  
 Test Item : Harmonic Radiated Emission Data  
 Test Site : No.3 OATS  
 Test Mode : Mode 2 SISO B: Transmit - 802.11n-20BW\_7.2Mbps(2.4G Band) (2467 MHz)

Frequency MHz	Correct Factor dB	Reading Level dBuV	Measurement Level dBuV/m	Margin dB	Limit dBuV/m
<b>Horizontal</b>					
<b>Peak Detector:</b>					
4934.000	2.830	37.320	40.151	-33.849	74.000
7401.000	12.218	36.880	49.098	-24.902	74.000
9868.000	13.043	36.970	50.012	-23.988	74.000
<b>Average Detector:</b>					
--					
<b>Vertical</b>					
<b>Peak Detector:</b>					
4934.000	5.530	37.220	42.751	-31.249	74.000
7401.000	13.345	36.830	50.176	-23.824	74.000
9868.000	13.602	36.540	50.141	-23.859	74.000
<b>Average Detector:</b>					
--					

Note:

1. All Readings below 1GHz are Quasi-Peak, above 1GHz are performed with peak and/or average measurements as necessary.
2. Peak measurements: RBW = 1MHz, VBW = 3 MHz, Sweep: Auto.
3. Average measurements: RBW = 1MHz, VBW = 10 Hz, Sweep: Auto.
4. Measurement Level = Reading Level + Correct Factor.
5. Correct Factor = Antenna factor + Cable loss – Amplifier gain.
6. The average measurement was not performed when the peak measured data under the limit of average detection.
7. The emission levels of other frequencies are very lower than the limit and not show in test report.

Product : Intel® Dual Band Wireless-AC 8260  
 Test Item : Harmonic Radiated Emission Data  
 Test Site : No.3 OATS  
 Test Mode : Mode 2 SISO B: Transmit - 802.11n-40BW\_15Mbps(2.4G Band) (2422MHz)

Frequency MHz	Correct Factor dB	Reading Level dBuV	Measurement Level dBuV/m	Margin dB	Limit dBuV/m
<b>Horizontal</b>					
<b>Peak Detector:</b>					
4844.000	3.171	38.480	41.651	-32.349	74.000
7266.000	11.162	37.120	48.282	-25.718	74.000
9688.000	12.964	36.580	49.545	-24.455	74.000
<b>Average Detector:</b>					
--					
<b>Vertical</b>					
<b>Peak Detector:</b>					
4844.000	6.178	38.780	44.958	-29.042	74.000
7266.000	11.982	36.740	48.722	-25.278	74.000
9688.000	13.507	36.690	50.198	-23.802	74.000
<b>Average Detector:</b>					
--					

Note:

1. All Readings below 1GHz are Quasi-Peak, above 1GHz are performed with peak and/or average measurements as necessary.
2. Peak measurements: RBW = 1MHz, VBW = 3 MHz, Sweep: Auto.
3. Average measurements: RBW = 1MHz, VBW = 10 Hz, Sweep: Auto.
4. Measurement Level = Reading Level + Correct Factor.
5. Correct Factor = Antenna factor + Cable loss –Amplifier gain.
6. The average measurement was not performed when the peak measured data under the limit of average detection.
7. The emission levels of other frequencies are very lower than the limit and not show in test report.

Product : Intel® Dual Band Wireless-AC 8260  
 Test Item : Harmonic Radiated Emission Data  
 Test Site : No.3 OATS  
 Test Mode : Mode 2 SISO B: Transmit - 802.11n-40BW\_15Mbps(2.4G Band) (2437 MHz)

Frequency	Correct	Reading	Measurement	Margin	Limit
MHz	Factor	Level	Level	dB	dBuV/m
	dB	dBuV	dBuV/m		

**Horizontal**

**Peak Detector:**

4874.000	3.038	38.260	41.297	-32.703	74.000
7311.000	11.795	37.140	48.934	-25.066	74.000
9748.000	12.635	36.680	49.315	-24.685	74.000

**Average**

**Detector:**

--

**Vertical**

**Peak Detector:**

4874.000	5.812	38.710	44.521	-29.479	74.000
7311.000	12.630	36.640	49.269	-24.731	74.000
9748.000	13.126	36.370	49.496	-24.504	74.000

**Average**

**Detector:**

--

Note:

1. All Readings below 1GHz are Quasi-Peak, above 1GHz are performed with peak and/or average measurements as necessary.
2. Peak measurements: RBW = 1MHz, VBW = 3 MHz, Sweep: Auto.
3. Average measurements: RBW = 1MHz, VBW = 10 Hz, Sweep: Auto.
4. Measurement Level = Reading Level + Correct Factor.
5. Correct Factor = Antenna factor + Cable loss – Amplifier gain.
6. The average measurement was not performed when the peak measured data under the limit of average detection.
7. The emission levels of other frequencies are very lower than the limit and not show in test report.

Product : Intel® Dual Band Wireless-AC 8260  
 Test Item : Harmonic Radiated Emission Data  
 Test Site : No.3 OATS  
 Test Mode : Mode 2 SISO B: Transmit - 802.11n-40BW\_15Mbps(2.4G Band) (2452 MHz)

Frequency MHz	Correct Factor dB	Reading Level dBuV	Measurement Level dBuV/m	Margin dB	Limit dBuV/m
<b>Horizontal</b>					
<b>Peak Detector:</b>					
4904.000	2.914	38.840	41.755	-32.245	74.000
7356.000	11.995	37.540	49.534	-24.466	74.000
9808.000	12.475	37.110	49.585	-24.415	74.000
<b>Average Detector:</b>					
--					
<b>Vertical</b>					
<b>Peak Detector:</b>					
4904.000	5.530	40.670	46.201	-27.799	74.000
7356.000	13.005	38.490	51.494	-22.506	74.000
9808.000	12.901	36.340	49.241	-24.759	74.000
<b>Average Detector:</b>					
--					

Note:

1. All Readings below 1GHz are Quasi-Peak, above 1GHz are performed with peak and/or average measurements as necessary.
2. Peak measurements: RBW = 1MHz, VBW = 3 MHz, Sweep: Auto.
3. Average measurements: RBW = 1MHz, VBW = 10 Hz, Sweep: Auto.
4. Measurement Level = Reading Level + Correct Factor.
5. Correct Factor = Antenna factor + Cable loss – Amplifier gain.
6. The average measurement was not performed when the peak measured data under the limit of average detection.
7. The emission levels of other frequencies are very lower than the limit and not show in test report.

Product : Intel® Dual Band Wireless-AC 8260  
 Test Item : Harmonic Radiated Emission Data  
 Test Site : No.3 OATS  
 Test Mode : Mode 2 SISO B: Transmit - 802.11n-40BW\_15Mbps(2.4G Band) (2457 MHz)

Frequency MHz	Correct Factor dB	Reading Level dBuV	Measurement Level dBuV/m	Margin dB	Limit dBuV/m
<b>Horizontal</b>					
<b>Peak Detector:</b>					
4914.000	2.883	37.580	40.463	-33.537	74.000
7371.000	12.062	36.490	48.552	-25.448	74.000
9828.000	12.664	36.650	49.314	-24.686	74.000
<b>Average Detector:</b>					
--					
<b>Vertical</b>					
<b>Peak Detector:</b>					
4914.000	5.508	37.420	42.928	-31.072	74.000
7371.000	13.130	36.380	49.510	-24.490	74.000
9828.000	13.135	36.670	49.805	-24.195	74.000
<b>Average Detector:</b>					
--					

Note:

1. All Readings below 1GHz are Quasi-Peak, above 1GHz are performed with peak and/or average measurements as necessary.
2. Peak measurements: RBW = 1MHz, VBW = 3 MHz, Sweep: Auto.
3. Average measurements: RBW = 1MHz, VBW = 10 Hz, Sweep: Auto.
4. Measurement Level = Reading Level + Correct Factor.
5. Correct Factor = Antenna factor + Cable loss – Amplifier gain.
6. The average measurement was not performed when the peak measured data under the limit of average detection.
7. The emission levels of other frequencies are very lower than the limit and not show in test report.

Product : Intel® Dual Band Wireless-AC 8260  
Test Item : Harmonic Radiated Emission Data  
Test Site : No.3 OATS  
Test Mode : Mode 2 SISO B: Transmit - 802.11n-20BW\_7.2Mbps(5G Band) (5745MHz)

Frequency MHz	Correct Factor dB	Reading Level dBuV	Measurement Level dBuV/m	Margin dB	Limit dBuV/m
<b>Horizontal</b>					
<b>Peak Detector:</b>					
11490.000	17.106	35.140	52.247	-21.753	74.000
<b>Average Detector:</b>					
--					
<b>Vertical</b>					
<b>Peak Detector:</b>					
11490.000	18.034	35.310	53.345	-20.655	74.000
<b>Average Detector:</b>					
--					

Note:

1. All Readings below 1GHz are Quasi-Peak, above 1GHz are performed with peak and/or average measurements as necessary.
2. Peak measurements: RBW = 1MHz, VBW = 3 MHz, Sweep: Auto.
3. Average measurements: RBW = 1MHz, VBW = 10 Hz, Sweep: Auto.
4. Measurement Level = Reading Level + Correct Factor.
5. Correct Factor = Antenna factor + Cable loss –Amplifier gain.
6. The average measurement was not performed when the peak measured data under the limit of average detection.
7. The emission levels of other frequencies are very lower than the limit and not show in test report.



Product : Intel® Dual Band Wireless-AC 8260  
 Test Item : Harmonic Radiated Emission Data  
 Test Site : No.3 OATS  
 Test Mode : Mode 2 SISO B: Transmit - 802.11n-20BW\_7.2Mbps(5G Band) (5785 MHz)

Frequency MHz	Correct Factor dB	Reading Level dBuV	Measurement Level dBuV/m	Margin dB	Limit dBuV/m
<b>Horizontal</b>					
<b>Peak Detector:</b>					
11570.000	16.809	35.380	52.189	-21.811	74.000
<b>Average Detector:</b>					
--					
<b>Vertical</b>					
<b>Peak Detector:</b>					
11570.000	17.698	35.660	53.358	-20.642	74.000
<b>Average Detector:</b>					
--					

Note:

1. All Readings below 1GHz are Quasi-Peak, above 1GHz are performed with peak and/or average measurements as necessary.
2. Peak measurements: RBW = 1MHz, VBW = 3 MHz, Sweep: Auto.
3. Average measurements: RBW = 1MHz, VBW = 10 Hz, Sweep: Auto.
4. Measurement Level = Reading Level + Correct Factor.
5. Correct Factor = Antenna factor + Cable loss –Amplifier gain.
6. The average measurement was not performed when the peak measured data under the limit of average detection.
7. The emission levels of other frequencies are very lower than the limit and not show in test report.

Product : Intel® Dual Band Wireless-AC 8260  
 Test Item : Harmonic Radiated Emission Data  
 Test Site : No.3 OATS  
 Test Mode : Mode 2 SISO B: Transmit - 802.11n-20BW\_7.2Mbps(5G Band) (5825 MHz)

Frequency MHz	Correct Factor dB	Reading Level dBuV	Measurement Level dBuV/m	Margin dB	Limit dBuV/m
<b>Horizontal</b>					
<b>Peak Detector:</b>					
11650.000	16.158	35.470	51.628	-22.372	74.000
<b>Average Detector:</b>					
--					
<b>Vertical</b>					
<b>Peak Detector:</b>					
11650.000	17.274	35.540	52.815	-21.185	74.000
<b>Average Detector:</b>					
--					

Note:

1. All Readings below 1GHz are Quasi-Peak, above 1GHz are performed with peak and/or average measurements as necessary.
2. Peak measurements: RBW = 1MHz, VBW = 3 MHz, Sweep: Auto.
3. Average measurements: RBW = 1MHz, VBW = 10 Hz, Sweep: Auto.
4. Measurement Level = Reading Level + Correct Factor.
5. Correct Factor = Antenna factor + Cable loss – Amplifier gain.
6. The average measurement was not performed when the peak measured data under the limit of average detection.
7. The emission levels of other frequencies are very lower than the limit and not show in test report.

Product : Intel® Dual Band Wireless-AC 8260  
 Test Item : Harmonic Radiated Emission Data  
 Test Site : No.3 OATS  
 Test Mode : Mode 2 SISO B: Transmit - 802.11n-40BW\_15Mbps(5G Band) (5755MHz)

Frequency MHz	Correct Factor dB	Reading Level dBuV	Measurement Level dBuV/m	Margin dB	Limit dBuV/m
<b>Horizontal</b>					
<b>Peak Detector:</b>					
11510.000	17.124	35.520	52.644	-21.356	74.000
<b>Average Detector:</b>					
--					
<b>Vertical</b>					
<b>Peak Detector:</b>					
11510.000	18.081	35.430	53.511	-20.489	74.000
<b>Average Detector:</b>					
--					

Note:

1. All Readings below 1GHz are Quasi-Peak, above 1GHz are performed with peak and/or average measurements as necessary.
2. Peak measurements: RBW = 1MHz, VBW = 3 MHz, Sweep: Auto.
3. Average measurements: RBW = 1MHz, VBW = 10 Hz, Sweep: Auto.
4. Measurement Level = Reading Level + Correct Factor.
5. Correct Factor = Antenna factor + Cable loss –Amplifier gain.
6. The average measurement was not performed when the peak measured data under the limit of average detection.
7. The emission levels of other frequencies are very lower than the limit and not show in test report.

Product : Intel® Dual Band Wireless-AC 8260  
 Test Item : Harmonic Radiated Emission Data  
 Test Site : No.3 OATS  
 Test Mode : Mode 2 SISO B: Transmit - 802.11n-40BW\_15Mbps(5G Band) (5795 MHz)

Frequency MHz	Correct Factor dB	Reading Level dBuV	Measurement Level dBuV/m	Margin dB	Limit dBuV/m
<b>Horizontal</b>					
<b>Peak Detector:</b>					
11590.000	16.701	35.760	52.460	-21.540	74.000
<b>Average Detector:</b>					
--					
<b>Vertical</b>					
<b>Peak Detector:</b>					
11590.000	17.567	35.410	52.976	-21.024	74.000
<b>Average Detector:</b>					
--					

Note:

1. All Readings below 1GHz are Quasi-Peak, above 1GHz are performed with peak and/or average measurements as necessary.
2. Peak measurements: RBW = 1MHz, VBW = 3 MHz, Sweep: Auto.
3. Average measurements: RBW = 1MHz, VBW = 10 Hz, Sweep: Auto.
4. Measurement Level = Reading Level + Correct Factor.
5. Correct Factor = Antenna factor + Cable loss – Amplifier gain.
6. The average measurement was not performed when the peak measured data under the limit of average detection.
7. The emission levels of other frequencies are very lower than the limit and not show in test report.

Product : Intel® Dual Band Wireless-AC 8260  
Test Item : Harmonic Radiated Emission Data  
Test Site : No.3 OATS  
Test Mode : Mode 2 SISO B: Transmit - 802.11ac-80BW\_32.5Mbps(5G Band) (5775 MHz)

Frequency MHz	Correct Factor dB	Reading Level dBuV	Measurement Level dBuV/m	Margin dB	Limit dBuV/m
<b>Horizontal</b>					
<b>Peak Detector:</b>					
11530.000	17.018	35.970	52.989	-21.011	74.000
<b>Average Detector:</b>					
--					
<b>Vertical</b>					
<b>Peak Detector:</b>					
11530.000	17.952	35.310	53.263	-20.737	74.000
<b>Average Detector:</b>					
--					

Note:

1. All Readings below 1GHz are Quasi-Peak, above 1GHz are performed with peak and/or average measurements as necessary.
2. Peak measurements: RBW = 1MHz, VBW = 3 MHz, Sweep: Auto.
3. Average measurements: RBW = 1MHz, VBW = 10 Hz, Sweep: Auto.
4. Measurement Level = Reading Level + Correct Factor.
5. Correct Factor = Antenna factor + Cable loss –Amplifier gain.
6. The average measurement was not performed when the peak measured data under the limit of average detection.
7. The emission levels of other frequencies are very lower than the limit and not show in test report.

Product : Intel® Dual Band Wireless-AC 8260  
Test Item : Harmonic Radiated Emission Data  
Test Site : No.3 OATS  
Test Mode : Mode 3 MIMO: Transmit - 802.11n-20BW\_14.4Mbps(2.4G Band) (2412MHz)

Frequency MHz	Correct Factor dB	Reading Level dBuV	Measurement Level dBuV/m	Margin dB	Limit dBuV/m
<b>Horizontal</b>					
<b>Peak Detector:</b>					
4824.000	3.261	38.450	41.711	-32.289	74.000
7236.000	10.650	39.650	50.300	-23.700	74.000
9648.000	13.337	37.440	50.776	-23.224	74.000
<b>Average Detector:</b>					
--					
<b>Vertical</b>					
<b>Peak Detector:</b>					
4824.000	6.421	40.280	46.701	-27.299	74.000
7236.000	11.495	38.270	49.765	-24.235	74.000
9648.000	13.807	37.150	50.956	-23.044	74.000
<b>Average Detector:</b>					
--					

Note:

1. All Readings below 1GHz are Quasi-Peak, above 1GHz are performed with peak and/or average measurements as necessary.
2. Peak measurements: RBW = 1MHz, VBW = 3 MHz, Sweep: Auto.
3. Average measurements: RBW = 1MHz, VBW = 10 Hz, Sweep: Auto.
4. Measurement Level = Reading Level + Correct Factor.
5. Correct Factor = Antenna factor + Cable loss –Amplifier gain.
6. The average measurement was not performed when the peak measured data under the limit of average detection.
7. The emission levels of other frequencies are very lower than the limit and not show in test report.

Product : Intel® Dual Band Wireless-AC 8260  
 Test Item : Harmonic Radiated Emission Data  
 Test Site : No.3 OATS  
 Test Mode : Mode 3 MIMO: Transmit - 802.11n-20BW\_14.4Mbps(2.4G Band) (2437 MHz)

Frequency MHz	Correct Factor dB	Reading Level dBuV	Measurement Level dBuV/m	Margin dB	Limit dBuV/m
<b>Horizontal</b>					
<b>Peak Detector:</b>					
4874.000	3.038	38.380	41.417	-32.583	74.000
7311.000	11.795	39.450	51.244	-22.756	74.000
9748.000	12.635	36.670	49.305	-24.695	74.000
<b>Average Detector:</b>					
--					
<b>Vertical</b>					
<b>Peak Detector:</b>					
4874.000	5.812	40.840	46.651	-27.349	74.000
7311.000	12.630	38.310	50.939	-23.061	74.000
9748.000	13.126	36.410	49.536	-24.464	74.000
<b>Average Detector:</b>					
--					

Note:

1. All Readings below 1GHz are Quasi-Peak, above 1GHz are performed with peak and/or average measurements as necessary.
2. Peak measurements: RBW = 1MHz, VBW = 3 MHz, Sweep: Auto.
3. Average measurements: RBW = 1MHz, VBW = 10 Hz, Sweep: Auto.
4. Measurement Level = Reading Level + Correct Factor.
5. Correct Factor = Antenna factor + Cable loss – Amplifier gain.
6. The average measurement was not performed when the peak measured data under the limit of average detection.
7. The emission levels of other frequencies are very lower than the limit and not show in test report.

Product : Intel® Dual Band Wireless-AC 8260  
 Test Item : Harmonic Radiated Emission Data  
 Test Site : No.3 OATS  
 Test Mode : Mode 3 MIMO: Transmit - 802.11n-20BW\_14.4Mbps(2.4G Band) (2462 MHz)

Frequency MHz	Correct Factor dB	Reading Level dBuV	Measurement Level dBuV/m	Margin dB	Limit dBuV/m
<b>Horizontal</b>					
<b>Peak Detector:</b>					
4924.000	2.858	38.450	41.307	-32.693	74.000
7386.000	12.127	39.550	51.678	-22.322	74.000
9848.000	12.852	37.560	50.413	-23.587	74.000
<b>Average Detector:</b>					
--					
<b>Vertical</b>					
<b>Peak Detector:</b>					
4924.000	5.521	40.560	46.080	-27.920	74.000
7386.000	13.254	38.470	51.724	-22.276	74.000
9848.000	13.367	36.290	49.657	-24.343	74.000
<b>Average Detector:</b>					
--					

Note:

1. All Readings below 1GHz are Quasi-Peak, above 1GHz are performed with peak and/or average measurements as necessary.
2. Peak measurements: RBW = 1MHz, VBW = 3 MHz, Sweep: Auto.
3. Average measurements: RBW = 1MHz, VBW = 10 Hz, Sweep: Auto.
4. Measurement Level = Reading Level + Correct Factor.
5. Correct Factor = Antenna factor + Cable loss – Amplifier gain.
6. The average measurement was not performed when the peak measured data under the limit of average detection.
7. The emission levels of other frequencies are very lower than the limit and not show in test report.



Product : Intel® Dual Band Wireless-AC 8260  
 Test Item : Harmonic Radiated Emission Data  
 Test Site : No.3 OATS  
 Test Mode : Mode 3 MIMO: Transmit - 802.11n-20BW\_14.4Mbps(2.4G Band) (2467 MHz)

Frequency MHz	Correct Factor dB	Reading Level dBuV	Measurement Level dBuV/m	Margin dB	Limit dBuV/m
<b>Horizontal</b>					
<b>Peak Detector:</b>					
4934.000	2.830	37.480	40.311	-33.689	74.000
7401.000	12.218	36.890	49.108	-24.892	74.000
9868.000	13.043	36.560	49.602	-24.398	74.000
<b>Average Detector:</b>					
--					
<b>Vertical</b>					
<b>Peak Detector:</b>					
4934.000	5.530	37.560	43.091	-30.909	74.000
7401.000	13.345	36.670	50.016	-23.984	74.000
9868.000	13.602	36.620	50.221	-23.779	74.000
<b>Average Detector:</b>					
--					

Note:

1. All Readings below 1GHz are Quasi-Peak, above 1GHz are performed with peak and/or average measurements as necessary.
2. Peak measurements: RBW = 1MHz, VBW = 3 MHz, Sweep: Auto.
3. Average measurements: RBW = 1MHz, VBW = 10 Hz, Sweep: Auto.
4. Measurement Level = Reading Level + Correct Factor.
5. Correct Factor = Antenna factor + Cable loss –Amplifier gain.
6. The average measurement was not performed when the peak measured data under the limit of average detection.
7. The emission levels of other frequencies are very lower than the limit and not show in test report.

Product : Intel® Dual Band Wireless-AC 8260  
Test Item : Harmonic Radiated Emission Data  
Test Site : No.3 OATS  
Test Mode : Mode 3 MIMO: Transmit - 802.11n-40BW\_30Mbps(2.4G Band) (2422MHz)

Frequency MHz	Correct Factor dB	Reading Level dBuV	Measurement Level dBuV/m	Margin dB	Limit dBuV/m
<b>Horizontal</b>					
<b>Peak Detector:</b>					
4844.000	3.171	38.450	41.621	-32.379	74.000
7266.000	11.162	37.120	48.282	-25.718	74.000
9688.000	12.964	36.540	49.505	-24.495	74.000
<b>Average Detector:</b>					
--					
<b>Vertical</b>					
<b>Peak Detector:</b>					
4844.000	6.178	38.850	45.028	-28.972	74.000
7266.000	11.982	36.560	48.542	-25.458	74.000
9688.000	13.507	36.670	50.178	-23.822	74.000
<b>Average Detector:</b>					
--					

Note:

1. All Readings below 1GHz are Quasi-Peak, above 1GHz are performed with peak and/or average measurements as necessary.
2. Peak measurements: RBW = 1MHz, VBW = 3 MHz, Sweep: Auto.
3. Average measurements: RBW = 1MHz, VBW = 10 Hz, Sweep: Auto.
4. Measurement Level = Reading Level + Correct Factor.
5. Correct Factor = Antenna factor + Cable loss – Amplifier gain.
6. The average measurement was not performed when the peak measured data under the limit of average detection.
7. The emission levels of other frequencies are very lower than the limit and not show in test report.

Product : Intel® Dual Band Wireless-AC 8260  
 Test Item : Harmonic Radiated Emission Data  
 Test Site : No.3 OATS  
 Test Mode : Mode 3 MIMO: Transmit - 802.11n-40BW\_30Mbps(2.4G Band) (2437 MHz)

Frequency	Correct	Reading	Measurement	Margin	Limit
MHz	Factor	Level	Level	dB	dBuV/m
	dB	dBuV	dBuV/m		

**Horizontal**

**Peak Detector:**

4874.000	3.038	38.340	41.377	-32.623	74.000
7311.000	11.795	37.120	48.914	-25.086	74.000
9748.000	12.635	36.640	49.275	-24.725	74.000

**Average  
Detector:**

--

**Vertical**

**Peak Detector:**

4874.000	5.812	38.750	44.561	-29.439	74.000
7311.000	12.630	36.680	49.309	-24.691	74.000
9748.000	13.126	36.240	49.366	-24.634	74.000

**Average  
Detector:**

--

Note:

1. All Readings below 1GHz are Quasi-Peak, above 1GHz are performed with peak and/or average measurements as necessary.
2. Peak measurements: RBW = 1MHz, VBW = 3 MHz, Sweep: Auto.
3. Average measurements: RBW = 1MHz, VBW = 10 Hz, Sweep: Auto.
4. Measurement Level = Reading Level + Correct Factor.
5. Correct Factor = Antenna factor + Cable loss – Amplifier gain.
6. The average measurement was not performed when the peak measured data under the limit of average detection.
7. The emission levels of other frequencies are very lower than the limit and not show in test report.

Product : Intel® Dual Band Wireless-AC 8260  
 Test Item : Harmonic Radiated Emission Data  
 Test Site : No.3 OATS  
 Test Mode : Mode 3 MIMO: Transmit - 802.11n-40BW\_30Mbps(2.4G Band) (2452 MHz)

Frequency MHz	Correct Factor dB	Reading Level dBuV	Measurement Level dBuV/m	Margin dB	Limit dBuV/m
<b>Horizontal</b>					
<b>Peak Detector:</b>					
4904.000	2.914	38.690	41.605	-32.395	74.000
7356.000	11.995	37.440	49.434	-24.566	74.000
9808.000	12.475	37.080	49.555	-24.445	74.000
<b>Average Detector:</b>					
--					
<b>Vertical</b>					
<b>Peak Detector:</b>					
4904.000	5.530	40.660	46.191	-27.809	74.000
7356.000	13.005	38.470	51.474	-22.526	74.000
9808.000	12.901	36.320	49.221	-24.779	74.000
<b>Average Detector:</b>					
--					

Note:

1. All Readings below 1GHz are Quasi-Peak, above 1GHz are performed with peak and/or average measurements as necessary.
2. Peak measurements: RBW = 1MHz, VBW = 3 MHz, Sweep: Auto.
3. Average measurements: RBW = 1MHz, VBW = 10 Hz, Sweep: Auto.
4. Measurement Level = Reading Level + Correct Factor.
5. Correct Factor = Antenna factor + Cable loss – Amplifier gain.
6. The average measurement was not performed when the peak measured data under the limit of average detection.
7. The emission levels of other frequencies are very lower than the limit and not show in test report.

Product : Intel® Dual Band Wireless-AC 8260  
 Test Item : Harmonic Radiated Emission Data  
 Test Site : No.3 OATS  
 Test Mode : Mode 3 MIMO: Transmit - 802.11n-40BW\_30Mbps(2.4G Band) (2457 MHz)

Frequency MHz	Correct Factor dB	Reading Level dBuV	Measurement Level dBuV/m	Margin dB	Limit dBuV/m
<b>Horizontal</b>					
<b>Peak Detector:</b>					
4914.000	2.883	37.540	40.423	-33.577	74.000
7371.000	12.062	36.380	48.442	-25.558	74.000
9828.000	12.664	36.690	49.354	-24.646	74.000
<b>Average Detector:</b>					
--					
<b>Vertical</b>					
<b>Peak Detector:</b>					
4914.000	5.508	37.850	43.358	-30.642	74.000
7371.000	13.130	36.540	49.670	-24.330	74.000
9828.000	13.135	36.840	49.975	-24.025	74.000
<b>Average Detector:</b>					
--					

Note:

1. All Readings below 1GHz are Quasi-Peak, above 1GHz are performed with peak and/or average measurements as necessary.
2. Peak measurements: RBW = 1MHz, VBW = 3 MHz, Sweep: Auto.
3. Average measurements: RBW = 1MHz, VBW = 10 Hz, Sweep: Auto.
4. Measurement Level = Reading Level + Correct Factor.
5. Correct Factor = Antenna factor + Cable loss –Amplifier gain.
6. The average measurement was not performed when the peak measured data under the limit of average detection.
7. The emission levels of other frequencies are very lower than the limit and not show in test report.

Product : Intel® Dual Band Wireless-AC 8260  
Test Item : Harmonic Radiated Emission Data  
Test Site : No.3 OATS  
Test Mode : Mode 3 MIMO: Transmit - 802.11n-20BW\_14.4Mbps(5G Band) (5745MHz)

Frequency MHz	Correct Factor dB	Reading Level dBuV	Measurement Level dBuV/m	Margin dB	Limit dBuV/m
<b>Horizontal</b>					
<b>Peak Detector:</b>					
11490.000	17.106	35.640	52.747	-21.253	74.000
<b>Average Detector:</b>					
--					
<b>Vertical</b>					
<b>Peak Detector:</b>					
11490.000	18.034	35.470	53.505	-20.495	74.000
<b>Average Detector:</b>					
--					

Note:

1. All Readings below 1GHz are Quasi-Peak, above 1GHz are performed with peak and/or average measurements as necessary.
2. Peak measurements: RBW = 1MHz, VBW = 3 MHz, Sweep: Auto.
3. Average measurements: RBW = 1MHz, VBW = 10 Hz, Sweep: Auto.
4. Measurement Level = Reading Level + Correct Factor.
5. Correct Factor = Antenna factor + Cable loss –Amplifier gain.
6. The average measurement was not performed when the peak measured data under the limit of average detection.
7. The emission levels of other frequencies are very lower than the limit and not show in test report.

Product : Intel® Dual Band Wireless-AC 8260  
Test Item : Harmonic Radiated Emission Data  
Test Site : No.3 OATS  
Test Mode : Mode 3 MIMO: Transmit - 802.11n-20BW\_14.4Mbps(5G Band) (5785 MHz)

Frequency MHz	Correct Factor dB	Reading Level dBuV	Measurement Level dBuV/m	Margin dB	Limit dBuV/m
<b>Horizontal</b>					
<b>Peak Detector:</b>					
11570.000	16.809	35.480	52.289	-21.711	74.000
<b>Average Detector:</b>					
--					
<b>Vertical</b>					
<b>Peak Detector:</b>					
11570.000	17.698	36.080	53.778	-20.222	74.000
<b>Average Detector:</b>					
--					

Note:

1. All Readings below 1GHz are Quasi-Peak, above 1GHz are performed with peak and/or average measurements as necessary.
2. Peak measurements: RBW = 1MHz, VBW = 3 MHz, Sweep: Auto.
3. Average measurements: RBW = 1MHz, VBW = 10 Hz, Sweep: Auto.
4. Measurement Level = Reading Level + Correct Factor.
5. Correct Factor = Antenna factor + Cable loss –Amplifier gain.
6. The average measurement was not performed when the peak measured data under the limit of average detection.
7. The emission levels of other frequencies are very lower than the limit and not show in test report.

Product : Intel® Dual Band Wireless-AC 8260  
Test Item : Harmonic Radiated Emission Data  
Test Site : No.3 OATS  
Test Mode : Mode 3 MIMO: Transmit - 802.11n-20BW\_14.4Mbps(5G Band) (5825 MHz)

Frequency MHz	Correct Factor dB	Reading Level dBuV	Measurement Level dBuV/m	Margin dB	Limit dBuV/m
<b>Horizontal</b>					
<b>Peak Detector:</b>					
11650.000	16.158	35.490	51.648	-22.352	74.000
<b>Average Detector:</b>					
--					
<b>Vertical</b>					
<b>Peak Detector:</b>					
11650.000	17.274	35.570	52.845	-21.155	74.000
<b>Average Detector:</b>					
--					

Note:

1. All Readings below 1GHz are Quasi-Peak, above 1GHz are performed with peak and/or average measurements as necessary.
2. Peak measurements: RBW = 1MHz, VBW = 3 MHz, Sweep: Auto.
3. Average measurements: RBW = 1MHz, VBW = 10 Hz, Sweep: Auto.
4. Measurement Level = Reading Level + Correct Factor.
5. Correct Factor = Antenna factor + Cable loss – Amplifier gain.
6. The average measurement was not performed when the peak measured data under the limit of average detection.
7. The emission levels of other frequencies are very lower than the limit and not show in test report.



Product : Intel® Dual Band Wireless-AC 8260  
 Test Item : Harmonic Radiated Emission Data  
 Test Site : No.3 OATS  
 Test Mode : Mode 3 MIMO: Transmit - 802.11n-40BW\_30Mbps(5G Band) (5755MHz)

Frequency MHz	Correct Factor dB	Reading Level dBuV	Measurement Level dBuV/m	Margin dB	Limit dBuV/m
<b>Horizontal</b>					
<b>Peak Detector:</b>					
11510.000	17.124	35.580	52.704	-21.296	74.000
<b>Average Detector:</b>					
--					
<b>Vertical</b>					
<b>Peak Detector:</b>					
11510.000	18.081	35.620	53.701	-20.299	74.000
<b>Average Detector:</b>					
--					

Note:

1. All Readings below 1GHz are Quasi-Peak, above 1GHz are performed with peak and/or average measurements as necessary.
2. Peak measurements: RBW = 1MHz, VBW = 3 MHz, Sweep: Auto.
3. Average measurements: RBW = 1MHz, VBW = 10 Hz, Sweep: Auto.
4. Measurement Level = Reading Level + Correct Factor.
5. Correct Factor = Antenna factor + Cable loss –Amplifier gain.
6. The average measurement was not performed when the peak measured data under the limit of average detection.
7. The emission levels of other frequencies are very lower than the limit and not show in test report.

Product : Intel® Dual Band Wireless-AC 8260  
Test Item : Harmonic Radiated Emission Data  
Test Site : No.3 OATS  
Test Mode : Mode 3 MIMO: Transmit - 802.11n-40BW\_30Mbps(5G Band) (5795 MHz)

Frequency MHz	Correct Factor dB	Reading Level dBuV	Measurement Level dBuV/m	Margin dB	Limit dBuV/m
<b>Horizontal</b>					
<b>Peak Detector:</b>					
11590.000	16.701	35.750	52.450	-21.550	74.000
<b>Average Detector:</b>					
--					
<b>Vertical</b>					
<b>Peak Detector:</b>					
11590.000	17.567	35.430	52.996	-21.004	74.000
<b>Average Detector:</b>					
--					

Note:

1. All Readings below 1GHz are Quasi-Peak, above 1GHz are performed with peak and/or average measurements as necessary.
2. Peak measurements: RBW = 1MHz, VBW = 3 MHz, Sweep: Auto.
3. Average measurements: RBW = 1MHz, VBW = 10 Hz, Sweep: Auto.
4. Measurement Level = Reading Level + Correct Factor.
5. Correct Factor = Antenna factor + Cable loss –Amplifier gain.
6. The average measurement was not performed when the peak measured data under the limit of average detection.
7. The emission levels of other frequencies are very lower than the limit and not show in test report.

Product : Intel® Dual Band Wireless-AC 8260  
Test Item : Harmonic Radiated Emission Data  
Test Site : No.3 OATS  
Test Mode : Mode 3 MIMO: Transmit - 802.11ac-80BW\_65Mbps(5G Band) (5775 MHz)

Frequency MHz	Correct Factor dB	Reading Level dBuV	Measurement Level dBuV/m	Margin dB	Limit dBuV/m
<b>Horizontal</b>					
<b>Peak Detector:</b>					
11530.000	17.018	36.120	53.139	-20.861	74.000
<b>Average Detector:</b>					
--					
<b>Vertical</b>					
<b>Peak Detector:</b>					
11530.000	17.952	35.290	53.243	-20.757	74.000
<b>Average Detector:</b>					
--					

Note:

1. All Readings below 1GHz are Quasi-Peak, above 1GHz are performed with peak and/or average measurements as necessary.
2. Peak measurements: RBW = 1MHz, VBW = 3 MHz, Sweep: Auto.
3. Average measurements: RBW = 1MHz, VBW = 10 Hz, Sweep: Auto.
4. Measurement Level = Reading Level + Correct Factor.
5. Correct Factor = Antenna factor + Cable loss –Amplifier gain.
6. The average measurement was not performed when the peak measured data under the limit of average detection.
7. The emission levels of other frequencies are very lower than the limit and not show in test report.

Product : Intel® Dual Band Wireless-AC 8260  
Test Item : Harmonic Radiated Emission Data  
Test Site : No.3 OATS  
Test Mode : Mode 4 Beamforming: Transmit - 802.11n-20BW\_14.4Mbps(2.4G Band) (2412MHz)

Frequency MHz	Correct Factor dB	Reading Level dBuV	Measurement Level dBuV/m	Margin dB	Limit dBuV/m
<b>Horizontal</b>					
<b>Peak Detector:</b>					
4824.000	3.261	38.420	41.681	-32.319	74.000
7236.000	10.650	39.650	50.300	-23.700	74.000
9648.000	13.337	37.350	50.686	-23.314	74.000
<b>Average Detector:</b>					
--					
<b>Vertical</b>					
<b>Peak Detector:</b>					
4824.000	6.421	40.150	46.571	-27.429	74.000
7236.000	11.495	38.250	49.745	-24.255	74.000
9648.000	13.807	37.110	50.916	-23.084	74.000
<b>Average Detector:</b>					
--					

Note:

1. All Readings below 1GHz are Quasi-Peak, above 1GHz are performed with peak and/or average measurements as necessary.
2. Peak measurements: RBW = 1MHz, VBW = 3 MHz, Sweep: Auto.
3. Average measurements: RBW = 1MHz, VBW = 10 Hz, Sweep: Auto.
4. Measurement Level = Reading Level + Correct Factor.
5. Correct Factor = Antenna factor + Cable loss – Amplifier gain.
6. The average measurement was not performed when the peak measured data under the limit of average detection.
7. The emission levels of other frequencies are very lower than the limit and not show in test report.

Product : Intel® Dual Band Wireless-AC 8260  
 Test Item : Harmonic Radiated Emission Data  
 Test Site : No.3 OATS  
 Test Mode : Mode 4 Beamforming: Transmit - 802.11n-20BW\_14.4Mbps(2.4G Band) (2437 MHz)

Frequency MHz	Correct Factor dB	Reading Level dBuV	Measurement Level dBuV/m	Margin dB	Limit dBuV/m
<b>Horizontal</b>					
<b>Peak Detector:</b>					
4874.000	3.038	38.410	41.447	-32.553	74.000
7311.000	11.795	39.340	51.134	-22.866	74.000
9748.000	12.635	36.690	49.325	-24.675	74.000
<b>Average Detector:</b>					
--					
<b>Vertical</b>					
<b>Peak Detector:</b>					
4874.000	5.812	40.790	46.601	-27.399	74.000
7311.000	12.630	38.270	50.899	-23.101	74.000
9748.000	13.126	36.520	49.646	-24.354	74.000
<b>Average Detector:</b>					
--					

Note:

1. All Readings below 1GHz are Quasi-Peak, above 1GHz are performed with peak and/or average measurements as necessary.
2. Peak measurements: RBW = 1MHz, VBW = 3 MHz, Sweep: Auto.
3. Average measurements: RBW = 1MHz, VBW = 10 Hz, Sweep: Auto.
4. Measurement Level = Reading Level + Correct Factor.
5. Correct Factor = Antenna factor + Cable loss – Amplifier gain.
6. The average measurement was not performed when the peak measured data under the limit of average detection.
7. The emission levels of other frequencies are very lower than the limit and not show in test report.

Product : Intel® Dual Band Wireless-AC 8260  
 Test Item : Harmonic Radiated Emission Data  
 Test Site : No.3 OATS  
 Test Mode : Mode 4 Beamforming: Transmit - 802.11n-20BW\_14.4Mbps(2.4G Band) (2462 MHz)

Frequency MHz	Correct Factor dB	Reading Level dBuV	Measurement Level dBuV/m	Margin dB	Limit dBuV/m
<b>Horizontal</b>					
<b>Peak Detector:</b>					
4924.000	2.858	38.460	41.317	-32.683	74.000
7386.000	12.127	39.540	51.668	-22.332	74.000
9848.000	12.852	37.590	50.443	-23.557	74.000
<b>Average Detector:</b>					
--					
<b>Vertical</b>					
<b>Peak Detector:</b>					
4924.000	5.521	40.610	46.130	-27.870	74.000
7386.000	13.254	38.390	51.644	-22.356	74.000
9848.000	13.367	36.410	49.777	-24.223	74.000
<b>Average Detector:</b>					
--					

Note:

1. All Readings below 1GHz are Quasi-Peak, above 1GHz are performed with peak and/or average measurements as necessary.
2. Peak measurements: RBW = 1MHz, VBW = 3 MHz, Sweep: Auto.
3. Average measurements: RBW = 1MHz, VBW = 10 Hz, Sweep: Auto.
4. Measurement Level = Reading Level + Correct Factor.
5. Correct Factor = Antenna factor + Cable loss – Amplifier gain.
6. The average measurement was not performed when the peak measured data under the limit of average detection.
7. The emission levels of other frequencies are very lower than the limit and not show in test report.

Product : Intel® Dual Band Wireless-AC 8260  
 Test Item : Harmonic Radiated Emission Data  
 Test Site : No.3 OATS  
 Test Mode : Mode 4 Beamforming: Transmit - 802.11n-20BW\_14.4Mbps(2.4G Band) (2467 MHz)

Frequency MHz	Correct Factor dB	Reading Level dBuV	Measurement Level dBuV/m	Margin dB	Limit dBuV/m
<b>Horizontal</b>					
<b>Peak Detector:</b>					
4934.000	2.830	38.240	41.071	-32.929	74.000
7401.000	12.218	37.250	49.468	-24.532	74.000
9868.000	13.043	37.140	50.182	-23.818	74.000
<b>Average Detector:</b>					
--					
<b>Vertical</b>					
<b>Peak Detector:</b>					
4934.000	5.530	38.100	43.631	-30.369	74.000
7401.000	13.345	37.050	50.396	-23.604	74.000
9868.000	13.602	37.080	50.681	-23.319	74.000
<b>Average Detector:</b>					
--					

Note:

1. All Readings below 1GHz are Quasi-Peak, above 1GHz are performed with peak and/or average measurements as necessary.
2. Peak measurements: RBW = 1MHz, VBW = 3 MHz, Sweep: Auto.
3. Average measurements: RBW = 1MHz, VBW = 10 Hz, Sweep: Auto.
4. Measurement Level = Reading Level + Correct Factor.
5. Correct Factor = Antenna factor + Cable loss – Amplifier gain.
6. The average measurement was not performed when the peak measured data under the limit of average detection.
7. The emission levels of other frequencies are very lower than the limit and not show in test report.

Product : Intel® Dual Band Wireless-AC 8260  
 Test Item : Harmonic Radiated Emission Data  
 Test Site : No.3 OATS  
 Test Mode : Mode 4 Beamforming: Transmit - 802.11n-40BW\_30Mbps(2.4G Band) (2422MHz)

Frequency MHz	Correct Factor dB	Reading Level dBuV	Measurement Level dBuV/m	Margin dB	Limit dBuV/m
<b>Horizontal</b>					
<b>Peak Detector:</b>					
4844.000	3.171	38.510	41.681	-32.319	74.000
7266.000	11.162	37.030	48.192	-25.808	74.000
9688.000	12.964	36.510	49.475	-24.525	74.000
<b>Average Detector:</b>					
--					
<b>Vertical</b>					
<b>Peak Detector:</b>					
4844.000	6.178	39.010	45.188	-28.812	74.000
7266.000	11.982	36.710	48.692	-25.308	74.000
9688.000	13.507	36.680	50.188	-23.812	74.000
<b>Average Detector:</b>					
--					

Note:

1. All Readings below 1GHz are Quasi-Peak, above 1GHz are performed with peak and/or average measurements as necessary.
2. Peak measurements: RBW = 1MHz, VBW = 3 MHz, Sweep: Auto.
3. Average measurements: RBW = 1MHz, VBW = 10 Hz, Sweep: Auto.
4. Measurement Level = Reading Level + Correct Factor.
5. Correct Factor = Antenna factor + Cable loss – Amplifier gain.
6. The average measurement was not performed when the peak measured data under the limit of average detection.
7. The emission levels of other frequencies are very lower than the limit and not show in test report.



Product : Intel® Dual Band Wireless-AC 8260  
 Test Item : Harmonic Radiated Emission Data  
 Test Site : No.3 OATS  
 Test Mode : Mode 4 Beamforming: Transmit - 802.11n-40BW\_30Mbps(2.4G Band) (2437 MHz)

Frequency	Correct	Reading	Measurement	Margin	Limit
MHz	Factor	Level	Level	dB	dBuV/m
	dB	dBuV	dBuV/m		

**Horizontal**

**Peak Detector:**

4874.000	3.038	38.350	41.387	-32.613	74.000
7311.000	11.795	37.120	48.914	-25.086	74.000
9748.000	12.635	36.640	49.275	-24.725	74.000

**Average**

**Detector:**

--

**Vertical**

**Peak Detector:**

4874.000	5.812	38.690	44.501	-29.499	74.000
7311.000	12.630	36.650	49.279	-24.721	74.000
9748.000	13.126	36.310	49.436	-24.564	74.000

**Average**

**Detector:**

--

Note:

1. All Readings below 1GHz are Quasi-Peak, above 1GHz are performed with peak and/or average measurements as necessary.
2. Peak measurements: RBW = 1MHz, VBW = 3 MHz, Sweep: Auto.
3. Average measurements: RBW = 1MHz, VBW = 10 Hz, Sweep: Auto.
4. Measurement Level = Reading Level + Correct Factor.
5. Correct Factor = Antenna factor + Cable loss – Amplifier gain.
6. The average measurement was not performed when the peak measured data under the limit of average detection.
7. The emission levels of other frequencies are very lower than the limit and not show in test report.

Product : Intel® Dual Band Wireless-AC 8260  
Test Item : Harmonic Radiated Emission Data  
Test Site : No.3 OATS  
Test Mode : Mode 4 Beamforming: Transmit - 802.11n-40BW\_30Mbps(2.4G Band) (2452 MHz)

Frequency MHz	Correct Factor dB	Reading Level dBuV	Measurement Level dBuV/m	Margin dB	Limit dBuV/m
<b>Horizontal</b>					
<b>Peak Detector:</b>					
4914.000	2.883	38.340	41.223	-32.777	74.000
7371.000	12.062	37.060	49.122	-24.878	74.000
9828.000	12.664	36.870	49.534	-24.466	74.000
<b>Average Detector:</b>					
--					
<b>Vertical</b>					
<b>Peak Detector:</b>					
4914.000	5.508	37.950	43.458	-30.542	74.000
7371.000	13.130	37.270	50.400	-23.600	74.000
9828.000	13.135	36.790	49.925	-24.075	74.000
<b>Average Detector:</b>					
--					

Note:

1. All Readings below 1GHz are Quasi-Peak, above 1GHz are performed with peak and/or average measurements as necessary.
2. Peak measurements: RBW = 1MHz, VBW = 3 MHz, Sweep: Auto.
3. Average measurements: RBW = 1MHz, VBW = 10 Hz, Sweep: Auto.
4. Measurement Level = Reading Level + Correct Factor.
5. Correct Factor = Antenna factor + Cable loss – Amplifier gain.
6. The average measurement was not performed when the peak measured data under the limit of average detection.
7. The emission levels of other frequencies are very lower than the limit and not show in test report.

Product : Intel® Dual Band Wireless-AC 8260  
 Test Item : Harmonic Radiated Emission Data  
 Test Site : No.3 OATS  
 Test Mode : Mode 4 Beamforming: Transmit - 802.11n-40BW\_30Mbps(2.4G Band) (2457 MHz)

Frequency MHz	Correct Factor dB	Reading Level dBuV	Measurement Level dBuV/m	Margin dB	Limit dBuV/m
<b>Horizontal</b>					
<b>Peak Detector:</b>					
4934.000	2.830	38.240	41.071	-32.929	74.000
7401.000	12.218	37.250	49.468	-24.532	74.000
9868.000	13.043	37.140	50.182	-23.818	74.000
<b>Average Detector:</b>					
--					
<b>Vertical</b>					
<b>Peak Detector:</b>					
4934.000	5.530	38.100	43.631	-30.369	74.000
7401.000	13.345	37.050	50.396	-23.604	74.000
9868.000	13.602	37.080	50.681	-23.319	74.000
<b>Average Detector:</b>					
--					

Note:

1. All Readings below 1GHz are Quasi-Peak, above 1GHz are performed with peak and/or average measurements as necessary.
2. Peak measurements: RBW = 1MHz, VBW = 3 MHz, Sweep: Auto.
3. Average measurements: RBW = 1MHz, VBW = 10 Hz, Sweep: Auto.
4. Measurement Level = Reading Level + Correct Factor.
5. Correct Factor = Antenna factor + Cable loss –Amplifier gain.
6. The average measurement was not performed when the peak measured data under the limit of average detection.
7. The emission levels of other frequencies are very lower than the limit and not show in test report.

Product : Intel® Dual Band Wireless-AC 8260  
Test Item : Harmonic Radiated Emission Data  
Test Site : No.3 OATS  
Test Mode : Mode 4 Beamforming: Transmit - 802.11n-20BW\_14.4Mbps(5G Band) (5745MHz)

Frequency MHz	Correct Factor dB	Reading Level dBuV	Measurement Level dBuV/m	Margin dB	Limit dBuV/m
<b>Horizontal</b>					
<b>Peak Detector:</b>					
11490.000	17.106	35.180	52.287	-21.713	74.000
<b>Average Detector:</b>					
--					
<b>Vertical</b>					
<b>Peak Detector:</b>					
11490.000	18.034	35.340	53.375	-20.625	74.000
<b>Average Detector:</b>					
--					

Note:

1. All Readings below 1GHz are Quasi-Peak, above 1GHz are performed with peak and/or average measurements as necessary.
2. Peak measurements: RBW = 1MHz, VBW = 3 MHz, Sweep: Auto.
3. Average measurements: RBW = 1MHz, VBW = 10 Hz, Sweep: Auto.
4. Measurement Level = Reading Level + Correct Factor.
5. Correct Factor = Antenna factor + Cable loss –Amplifier gain.
6. The average measurement was not performed when the peak measured data under the limit of average detection.
7. The emission levels of other frequencies are very lower than the limit and not show in test report.

Product : Intel® Dual Band Wireless-AC 8260  
Test Item : Harmonic Radiated Emission Data  
Test Site : No.3 OATS  
Test Mode : Mode 4 Beamforming: Transmit - 802.11n-20BW\_14.4Mbps(5G Band) (5785 MHz)

Frequency MHz	Correct Factor dB	Reading Level dBuV	Measurement Level dBuV/m	Margin dB	Limit dBuV/m
<b>Horizontal</b>					
<b>Peak Detector:</b>					
11570.000	16.809	35.480	52.289	-21.711	74.000
<b>Average Detector:</b>					
--					
<b>Vertical</b>					
<b>Peak Detector:</b>					
11570.000	17.698	35.640	53.338	-20.662	74.000
<b>Average Detector:</b>					
--					

Note:

1. All Readings below 1GHz are Quasi-Peak, above 1GHz are performed with peak and/or average measurements as necessary.
2. Peak measurements: RBW = 1MHz, VBW = 3 MHz, Sweep: Auto.
3. Average measurements: RBW = 1MHz, VBW = 10 Hz, Sweep: Auto.
4. Measurement Level = Reading Level + Correct Factor.
5. Correct Factor = Antenna factor + Cable loss –Amplifier gain.
6. The average measurement was not performed when the peak measured data under the limit of average detection.
7. The emission levels of other frequencies are very lower than the limit and not show in test report.

Product : Intel® Dual Band Wireless-AC 8260  
 Test Item : Harmonic Radiated Emission Data  
 Test Site : No.3 OATS  
 Test Mode : Mode 4 Beamforming: Transmit - 802.11n-20BW\_14.4Mbps(5G Band) (5825 MHz)

Frequency MHz	Correct Factor dB	Reading Level dBuV	Measurement Level dBuV/m	Margin dB	Limit dBuV/m
<b>Horizontal</b>					
<b>Peak Detector:</b>					
11650.000	16.158	35.450	51.608	-22.392	74.000
<b>Average Detector:</b>					
--					
<b>Vertical</b>					
<b>Peak Detector:</b>					
11650.000	17.274	35.540	52.815	-21.185	74.000
<b>Average Detector:</b>					
--					

Note:

1. All Readings below 1GHz are Quasi-Peak, above 1GHz are performed with peak and/or average measurements as necessary.
2. Peak measurements: RBW = 1MHz, VBW = 3 MHz, Sweep: Auto.
3. Average measurements: RBW = 1MHz, VBW = 10 Hz, Sweep: Auto.
4. Measurement Level = Reading Level + Correct Factor.
5. Correct Factor = Antenna factor + Cable loss – Amplifier gain.
6. The average measurement was not performed when the peak measured data under the limit of average detection.
7. The emission levels of other frequencies are very lower than the limit and not show in test report.

Product : Intel® Dual Band Wireless-AC 8260  
Test Item : Harmonic Radiated Emission Data  
Test Site : No.3 OATS  
Test Mode : Mode 4 Beamforming: Transmit - 802.11n-40BW\_30Mbps(5G Band) (5755MHz)

Frequency MHz	Correct Factor dB	Reading Level dBuV	Measurement Level dBuV/m	Margin dB	Limit dBuV/m
<b>Horizontal</b>					
<b>Peak Detector:</b>					
11510.000	17.124	35.580	52.704	-21.296	74.000
<b>Average Detector:</b>					
--					
<b>Vertical</b>					
<b>Peak Detector:</b>					
11510.000	18.081	35.640	53.721	-20.279	74.000
<b>Average Detector:</b>					
--					

Note:

1. All Readings below 1GHz are Quasi-Peak, above 1GHz are performed with peak and/or average measurements as necessary.
2. Peak measurements: RBW = 1MHz, VBW = 3 MHz, Sweep: Auto.
3. Average measurements: RBW = 1MHz, VBW = 10 Hz, Sweep: Auto.
4. Measurement Level = Reading Level + Correct Factor.
5. Correct Factor = Antenna factor + Cable loss –Amplifier gain.
6. The average measurement was not performed when the peak measured data under the limit of average detection.
7. The emission levels of other frequencies are very lower than the limit and not show in test report.

Product : Intel® Dual Band Wireless-AC 8260  
Test Item : Harmonic Radiated Emission Data  
Test Site : No.3 OATS  
Test Mode : Mode 4 Beamforming: Transmit - 802.11n-40BW\_30Mbps(5G Band) (5795 MHz)

Frequency MHz	Correct Factor dB	Reading Level dBuV	Measurement Level dBuV/m	Margin dB	Limit dBuV/m
<b>Horizontal</b>					
<b>Peak Detector:</b>					
11590.000	16.701	35.790	52.490	-21.510	74.000
<b>Average Detector:</b>					
--					
<b>Vertical</b>					
<b>Peak Detector:</b>					
11590.000	17.567	35.480	53.046	-20.954	74.000
<b>Average Detector:</b>					
--					

Note:

1. All Readings below 1GHz are Quasi-Peak, above 1GHz are performed with peak and/or average measurements as necessary.
2. Peak measurements: RBW = 1MHz, VBW = 3 MHz, Sweep: Auto.
3. Average measurements: RBW = 1MHz, VBW = 10 Hz, Sweep: Auto.
4. Measurement Level = Reading Level + Correct Factor.
5. Correct Factor = Antenna factor + Cable loss –Amplifier gain.
6. The average measurement was not performed when the peak measured data under the limit of average detection.
7. The emission levels of other frequencies are very lower than the limit and not show in test report.



Product : Intel® Dual Band Wireless-AC 8260  
Test Item : Harmonic Radiated Emission Data  
Test Site : No.3 OATS  
Test Mode : Mode 4 Beamforming: Transmit - 802.11ac-80BW\_65Mbps(5G Band) (5775 MHz)

Frequency MHz	Correct Factor dB	Reading Level dBuV	Measurement Level dBuV/m	Margin dB	Limit dBuV/m
<b>Horizontal</b>					
<b>Peak Detector:</b>					
11530.000	17.018	36.120	53.139	-20.861	74.000
<b>Average Detector:</b>					
--					
<b>Vertical</b>					
<b>Peak Detector:</b>					
11530.000	17.952	35.270	53.223	-20.777	74.000
<b>Average Detector:</b>					
--					

Note:

1. All Readings below 1GHz are Quasi-Peak, above 1GHz are performed with peak and/or average measurements as necessary.
2. Peak measurements: RBW = 1MHz, VBW = 3 MHz, Sweep: Auto.
3. Average measurements: RBW = 1MHz, VBW = 10 Hz, Sweep: Auto.
4. Measurement Level = Reading Level + Correct Factor.
5. Correct Factor = Antenna factor + Cable loss –Amplifier gain.
6. The average measurement was not performed when the peak measured data under the limit of average detection.
7. The emission levels of other frequencies are very lower than the limit and not show in test report.

Product : Intel® Dual Band Wireless-AC 8260  
 Test Item : General Radiated Emission Data  
 Test Site : No.3 OATS  
 Test Mode : Mode 1 SISO A: Transmit (802.11b 1Mbps) (2437 MHz)

Frequency MHz	Correct Factor dB	Reading Level dBuV	Measurement Level dBuV/m	Margin dB	Limit dBuV/m
<b>Horizontal</b>					
212.360	-10.540	39.660	29.120	-14.380	43.500
346.220	-1.490	36.651	35.160	-10.840	46.000
489.780	1.326	35.913	37.239	-8.761	46.000
619.760	1.866	36.205	38.071	-7.929	46.000
778.840	4.951	32.853	37.804	-8.196	46.000
906.880	5.880	24.870	30.750	-15.250	46.000
<b>Vertical</b>					
258.920	-5.029	37.115	32.086	-13.914	46.000
402.480	-3.650	37.009	33.359	-12.641	46.000
526.640	0.960	35.309	36.269	-9.731	46.000
687.660	2.124	35.863	37.987	-8.013	46.000
827.340	2.430	35.249	37.679	-8.321	46.000
961.200	3.110	30.341	33.451	-20.549	54.000

Note:

1. All Readings below 1GHz are Quasi-Peak, above 1GHz are performed with peak and/or average measurements as necessary.
2. Peak measurements: RBW = 1MHz, VBW = 3 MHz, Sweep: Auto.
3. Average measurements: RBW = 1MHz, VBW = 10 Hz, Sweep: Auto.
4. Measurement Level = Reading Level + Correct Factor.
5. Correct Factor = Antenna factor + Cable loss – Amplifier gain.
6. The average measurement was not performed when the peak measured data under the limit of average detection.
7. The emission levels of other frequencies are very lower than the limit and not show in test report.
8. No emission found between lowest internal used/generated frequency to 30MHz.

Product : Intel® Dual Band Wireless-AC 8260  
 Test Item : General Radiated Emission Data  
 Test Site : No.3 OATS  
 Test Mode : Mode 1 SISO A: Transmit (802.11g 6Mbps) (2437 MHz)

Frequency MHz	Correct Factor dB	Reading Level dBuV	Measurement Level dBuV/m	Margin dB	Limit dBuV/m
<b>Horizontal</b>					
218.180	-10.376	41.317	30.941	-15.059	46.000
342.340	-2.710	39.136	36.426	-9.574	46.000
464.560	2.760	36.553	39.313	-6.687	46.000
588.720	3.060	36.057	39.117	-6.883	46.000
745.860	3.700	34.823	38.523	-7.477	46.000
918.520	6.468	26.429	32.897	-13.103	46.000
<b>Vertical</b>					
225.940	-6.410	36.393	29.983	-16.017	46.000
375.320	0.286	32.767	33.052	-12.948	46.000
547.980	0.030	37.341	37.371	-8.629	46.000
660.500	-1.267	38.380	37.113	-8.887	46.000
809.880	2.770	34.859	37.629	-8.371	46.000
968.960	3.740	28.249	31.989	-22.011	54.000

Note:

1. All Readings below 1GHz are Quasi-Peak, above 1GHz are performed with peak and/or average measurements as necessary.
2. Peak measurements: RBW = 1MHz, VBW = 3 MHz, Sweep: Auto.
3. Average measurements: RBW = 1MHz, VBW = 10 Hz, Sweep: Auto.
4. Measurement Level = Reading Level + Correct Factor.
5. Correct Factor = Antenna factor + Cable loss – Amplifier gain.
6. The average measurement was not performed when the peak measured data under the limit of average detection.
7. The emission levels of other frequencies are very lower than the limit and not show in test report.
8. No emission found between lowest internal used/generated frequency to 30MHz.

Product : Intel® Dual Band Wireless-AC 8260  
 Test Item : General Radiated Emission Data  
 Test Site : No.3 OATS  
 Test Mode : Mode 1 SISO A: Transmit - 802.11a 6Mbps (5785MHz)

Frequency MHz	Correct Factor dB	Reading Level dBuV	Measurement Level dBuV/m	Margin dB	Limit dBuV/m
<b>Horizontal</b>					
224.000	-10.210	41.766	31.556	-14.444	46.000
357.860	-0.846	36.377	35.531	-10.469	46.000
503.360	1.810	36.581	38.391	-7.609	46.000
635.280	1.620	37.112	38.732	-7.268	46.000
790.480	6.131	31.720	37.851	-8.149	46.000
949.560	6.824	24.127	30.951	-15.049	46.000
<b>Vertical</b>					
210.420	-5.816	37.984	32.169	-11.331	43.500
342.340	-1.080	35.078	33.998	-12.002	46.000
505.300	-0.130	37.561	37.431	-8.569	46.000
695.420	1.180	35.764	36.944	-9.056	46.000
829.280	2.091	34.186	36.277	-9.723	46.000
932.100	3.197	29.288	32.485	-13.515	46.000

Note:

1. All Readings below 1GHz are Quasi-Peak, above 1GHz are performed with peak and/or average measurements as necessary.
2. Peak measurements: RBW = 1MHz, VBW = 3 MHz, Sweep: Auto.
3. Average measurements: RBW = 1MHz, VBW = 10 Hz, Sweep: Auto.
4. Measurement Level = Reading Level + Correct Factor.
5. Correct Factor = Antenna factor + Cable loss –Amplifier gain.
6. The average measurement was not performed when the peak measured data under the limit of average detection.
7. The emission levels of other frequencies are very lower than the limit and not show in test report.
8. No emission found between lowest internal used/generated frequency to 30MHz.

Product : Intel® Dual Band Wireless-AC 8260  
 Test Item : General Radiated Emission Data  
 Test Site : No.3 OATS  
 Test Mode : Mode 1 SISO A: Transmit - 802.11n-20BW\_7.2Mbps(2.4G Band) (2437 MHz)

Frequency MHz	Correct Factor dB	Reading Level dBuV	Measurement Level dBuV/m	Margin dB	Limit dBuV/m
<b>Horizontal</b>					
229.820	-8.137	39.876	31.739	-14.261	46.000
377.260	1.008	34.579	35.587	-10.413	46.000
491.720	1.350	35.632	36.982	-9.018	46.000
631.400	1.085	35.462	36.547	-9.453	46.000
786.600	5.594	32.238	37.833	-8.167	46.000
935.980	6.530	24.993	31.523	-14.477	46.000
<b>Vertical</b>					
237.580	-6.670	38.367	31.697	-14.303	46.000
383.080	0.099	35.345	35.444	-10.556	46.000
515.000	-0.107	38.357	38.250	-7.750	46.000
679.900	1.058	36.793	37.851	-8.149	46.000
813.760	2.620	34.918	37.538	-8.462	46.000
949.560	2.944	31.395	34.339	-11.661	46.000

Note:

1. All Readings below 1GHz are Quasi-Peak, above 1GHz are performed with peak and/or average measurements as necessary.
2. Peak measurements: RBW = 1MHz, VBW = 3 MHz, Sweep: Auto.
3. Average measurements: RBW = 1MHz, VBW = 10 Hz, Sweep: Auto.
4. Measurement Level = Reading Level + Correct Factor.
5. Correct Factor = Antenna factor + Cable loss –Amplifier gain.
6. The average measurement was not performed when the peak measured data under the limit of average detection.
7. The emission levels of other frequencies are very lower than the limit and not show in test report.
8. No emission found between lowest internal used/generated frequency to 30MHz.

Product : Intel® Dual Band Wireless-AC 8260  
 Test Item : General Radiated Emission Data  
 Test Site : No.3 OATS  
 Test Mode : Mode 1 SISO A: Transmit - 802.11n-40BW\_15Mbps(2.4G Band) (2437 MHz)

Frequency MHz	Correct Factor dB	Reading Level dBuV	Measurement Level dBuV/m	Margin dB	Limit dBuV/m
<b>Horizontal</b>					
227.880	-8.908	39.587	30.680	-15.320	46.000
381.140	1.292	33.572	34.864	-11.136	46.000
505.300	1.940	33.626	35.566	-10.434	46.000
652.740	1.744	35.107	36.851	-9.149	46.000
819.580	6.690	29.440	36.130	-9.870	46.000
957.320	6.410	24.973	31.383	-14.617	46.000
<b>Vertical</b>					
214.300	-6.018	35.210	29.191	-14.309	43.500
338.460	-1.792	38.039	36.246	-9.754	46.000
460.680	-2.080	40.091	38.011	-7.989	46.000
596.480	0.677	37.132	37.809	-8.191	46.000
796.300	2.400	33.969	36.369	-9.631	46.000
941.800	3.240	28.841	32.081	-13.919	46.000

Note:

1. All Readings below 1GHz are Quasi-Peak, above 1GHz are performed with peak and/or average measurements as necessary.
2. Peak measurements: RBW = 1MHz, VBW = 3 MHz, Sweep: Auto.
3. Average measurements: RBW = 1MHz, VBW = 10 Hz, Sweep: Auto.
4. Measurement Level = Reading Level + Correct Factor.
5. Correct Factor = Antenna factor + Cable loss – Amplifier gain.
6. The average measurement was not performed when the peak measured data under the limit of average detection.
7. The emission levels of other frequencies are very lower than the limit and not show in test report.
8. No emission found between lowest internal used/generated frequency to 30MHz.

Product : Intel® Dual Band Wireless-AC 8260  
 Test Item : General Radiated Emission Data  
 Test Site : No.3 OATS  
 Test Mode : Mode 1 SISO A: Transmit - 802.11n-20BW\_7.2Mbps(5G Band) (5785 MHz)

Frequency MHz	Correct Factor dB	Reading Level dBuV	Measurement Level dBuV/m	Margin dB	Limit dBuV/m
<b>Horizontal</b>					
249.220	-6.340	38.784	32.444	-13.556	46.000
383.080	1.209	34.879	36.088	-9.912	46.000
532.460	2.902	34.996	37.898	-8.102	46.000
674.080	2.550	36.759	39.309	-6.691	46.000
809.880	6.010	32.519	38.529	-7.471	46.000
953.440	6.529	28.846	35.375	-10.625	46.000
<b>Vertical</b>					
220.120	-6.690	38.775	32.085	-13.915	46.000
357.860	-1.366	37.152	35.786	-10.214	46.000
499.480	-0.379	37.765	37.386	-8.614	46.000
635.280	-1.590	39.049	37.459	-8.541	46.000
792.420	2.447	34.212	36.659	-9.341	46.000
935.980	2.590	29.801	32.391	-13.609	46.000

Note:

1. All Readings below 1GHz are Quasi-Peak, above 1GHz are performed with peak and/or average measurements as necessary.
2. Peak measurements: RBW = 1MHz, VBW = 3 MHz, Sweep: Auto.
3. Average measurements: RBW = 1MHz, VBW = 10 Hz, Sweep: Auto.
4. Measurement Level = Reading Level + Correct Factor.
5. Correct Factor = Antenna factor + Cable loss – Amplifier gain.
6. The average measurement was not performed when the peak measured data under the limit of average detection.
7. The emission levels of other frequencies are very lower than the limit and not show in test report.
8. No emission found between lowest internal used/generated frequency to 30MHz.

Product : Intel® Dual Band Wireless-AC 8260  
 Test Item : General Radiated Emission Data  
 Test Site : No.3 OATS  
 Test Mode : Mode 1 SISO A: Transmit - 802.11n-40BW\_15Mbps(5G Band) (5755MHz)

Frequency MHz	Correct Factor dB	Reading Level dBuV	Measurement Level dBuV/m	Margin dB	Limit dBuV/m
<b>Horizontal</b>					
227.880	-8.908	39.587	30.680	-15.320	46.000
381.140	1.292	33.572	34.864	-11.136	46.000
505.300	1.940	33.626	35.566	-10.434	46.000
652.740	1.744	35.107	36.851	-9.149	46.000
819.580	6.690	29.440	36.130	-9.870	46.000
957.320	6.410	24.973	31.383	-14.617	46.000
<b>Vertical</b>					
214.300	-6.018	35.210	29.191	-14.309	43.500
338.460	-1.792	38.039	36.246	-9.754	46.000
460.680	-2.080	40.091	38.011	-7.989	46.000
596.480	0.677	37.132	37.809	-8.191	46.000
796.300	2.400	33.969	36.369	-9.631	46.000
941.800	3.240	28.841	32.081	-13.919	46.000

Note:

1. All Readings below 1GHz are Quasi-Peak, above 1GHz are performed with peak and/or average measurements as necessary.
2. Peak measurements: RBW = 1MHz, VBW = 3 MHz, Sweep: Auto.
3. Average measurements: RBW = 1MHz, VBW = 10 Hz, Sweep: Auto.
4. Measurement Level = Reading Level + Correct Factor.
5. Correct Factor = Antenna factor + Cable loss – Amplifier gain.
6. The average measurement was not performed when the peak measured data under the limit of average detection.
7. The emission levels of other frequencies are very lower than the limit and not show in test report.
8. No emission found between lowest internal used/generated frequency to 30MHz.



Product : Intel® Dual Band Wireless-AC 8260  
 Test Item : General Radiated Emission Data  
 Test Site : No.3 OATS  
 Test Mode : Mode 1 SISO A: Transmit - 802.11ac-80BW\_32.5Mbps(5G Band) (5775MHz)

Frequency MHz	Correct Factor dB	Reading Level dBuV	Measurement Level dBuV/m	Margin dB	Limit dBuV/m
<b>Horizontal</b>					
206.540	-10.696	41.201	30.505	-12.995	43.500
346.220	-1.490	35.180	33.689	-12.311	46.000
491.720	1.350	35.470	36.820	-9.180	46.000
619.760	1.866	36.210	38.076	-7.924	46.000
751.680	4.120	32.344	36.464	-9.536	46.000
922.400	6.425	24.806	31.231	-14.769	46.000
<b>Vertical</b>					
224.000	-6.520	38.172	31.652	-14.348	46.000
367.560	-0.196	35.821	35.624	-10.376	46.000
532.460	1.012	35.914	36.926	-9.074	46.000
699.300	-0.200	37.243	37.043	-8.957	46.000
844.800	2.163	35.510	37.673	-8.327	46.000
965.080	3.638	28.317	31.955	-22.045	54.000

Note:

1. All Readings below 1GHz are Quasi-Peak, above 1GHz are performed with peak and/or average measurements as necessary.
2. Peak measurements: RBW = 1MHz, VBW = 3 MHz, Sweep: Auto.
3. Average measurements: RBW = 1MHz, VBW = 10 Hz, Sweep: Auto.
4. Measurement Level = Reading Level + Correct Factor.
5. Correct Factor = Antenna factor + Cable loss – Amplifier gain.
6. The average measurement was not performed when the peak measured data under the limit of average detection.
7. The emission levels of other frequencies are very lower than the limit and not show in test report.
8. No emission found between lowest internal used/generated frequency to 30MHz.

Product : Intel® Dual Band Wireless-AC 8260  
 Test Item : General Radiated Emission Data  
 Test Site : No.3 OATS  
 Test Mode : Mode 2 SISO B: Transmit (802.11b 1Mbps) (2437 MHz)

Frequency MHz	Correct Factor dB	Reading Level dBuV	Measurement Level dBuV/m	Margin dB	Limit dBuV/m
<b>Horizontal</b>					
212.360	-10.540	41.121	30.581	-12.919	43.500
342.340	-2.710	37.554	34.844	-11.156	46.000
505.300	1.940	35.026	36.966	-9.034	46.000
652.740	1.744	35.741	37.485	-8.515	46.000
782.720	5.154	33.165	38.319	-7.681	46.000
939.860	6.530	25.057	31.587	-14.413	46.000
<b>Vertical</b>					
216.240	-6.206	40.113	33.907	-12.093	46.000
359.800	-1.440	39.240	37.801	-8.199	46.000
518.880	0.570	37.908	38.478	-7.522	46.000
681.840	1.455	36.060	37.515	-8.485	46.000
815.700	2.665	35.143	37.808	-8.192	46.000
967.020	3.695	29.320	33.015	-20.985	54.000

Note:

1. All Readings below 1GHz are Quasi-Peak, above 1GHz are performed with peak and/or average measurements as necessary.
2. Peak measurements: RBW = 1MHz, VBW = 3 MHz, Sweep: Auto.
3. Average measurements: RBW = 1MHz, VBW = 10 Hz, Sweep: Auto.
4. Measurement Level = Reading Level + Correct Factor.
5. Correct Factor = Antenna factor + Cable loss – Amplifier gain.
6. The average measurement was not performed when the peak measured data under the limit of average detection.
7. The emission levels of other frequencies are very lower than the limit and not show in test report.
8. No emission found between lowest internal used/generated frequency to 30MHz.

Product : Intel® Dual Band Wireless-AC 8260  
 Test Item : General Radiated Emission Data  
 Test Site : No.3 OATS  
 Test Mode : Mode 2 SISO B: Transmit (802.11g 6Mbps) (2437 MHz)

Frequency MHz	Correct Factor dB	Reading Level dBuV	Measurement Level dBuV/m	Margin dB	Limit dBuV/m
<b>Horizontal</b>					
212.360	-10.540	42.367	31.827	-11.673	43.500
357.860	-0.846	37.792	36.946	-9.054	46.000
483.960	1.288	36.717	38.005	-7.995	46.000
602.300	3.560	34.612	38.172	-7.828	46.000
734.220	2.961	33.541	36.502	-9.498	46.000
901.060	5.603	26.888	32.491	-13.509	46.000
<b>Vertical</b>					
198.780	-5.880	38.182	32.302	-11.198	43.500
293.840	-5.184	41.373	36.190	-9.810	46.000
468.440	-3.724	41.469	37.745	-8.255	46.000
631.400	-1.635	37.368	35.733	-10.267	46.000
778.840	2.351	35.875	38.226	-7.774	46.000
928.220	3.400	29.309	32.709	-13.291	46.000

Note:

1. All Readings below 1GHz are Quasi-Peak, above 1GHz are performed with peak and/or average measurements as necessary.
2. Peak measurements: RBW = 1MHz, VBW = 3 MHz, Sweep: Auto.
3. Average measurements: RBW = 1MHz, VBW = 10 Hz, Sweep: Auto.
4. Measurement Level = Reading Level + Correct Factor.
5. Correct Factor = Antenna factor + Cable loss – Amplifier gain.
6. The average measurement was not performed when the peak measured data under the limit of average detection.
7. The emission levels of other frequencies are very lower than the limit and not show in test report.
8. No emission found between lowest internal used/generated frequency to 30MHz.

Product : Intel® Dual Band Wireless-AC 8260  
 Test Item : General Radiated Emission Data  
 Test Site : No.3 OATS  
 Test Mode : Mode 2 SISO B: Transmit - 802.11a 6Mbps (5785MHz)

Frequency MHz	Correct Factor dB	Reading Level dBuV	Measurement Level dBuV/m	Margin dB	Limit dBuV/m
<b>Horizontal</b>					
214.300	-10.488	40.831	30.342	-13.158	43.500
346.220	-1.490	36.530	35.039	-10.961	46.000
454.860	1.611	36.054	37.665	-8.335	46.000
617.820	2.229	35.574	37.803	-8.197	46.000
763.320	4.899	32.530	37.429	-8.571	46.000
922.400	6.425	26.976	33.401	-12.599	46.000
<b>Vertical</b>					
202.660	-5.748	37.387	31.640	-11.860	43.500
352.040	-1.422	36.282	34.861	-11.139	46.000
520.820	0.886	37.021	37.906	-8.094	46.000
662.440	-1.151	38.407	37.256	-8.744	46.000
806.000	3.433	34.927	38.360	-7.640	46.000
955.380	2.750	29.220	31.970	-14.030	46.000

Note:

1. All Readings below 1GHz are Quasi-Peak, above 1GHz are performed with peak and/or average measurements as necessary.
2. Peak measurements: RBW = 1MHz, VBW = 3 MHz, Sweep: Auto.
3. Average measurements: RBW = 1MHz, VBW = 10 Hz, Sweep: Auto.
4. Measurement Level = Reading Level + Correct Factor.
5. Correct Factor = Antenna factor + Cable loss – Amplifier gain.
6. The average measurement was not performed when the peak measured data under the limit of average detection.
7. The emission levels of other frequencies are very lower than the limit and not show in test report.
8. No emission found between lowest internal used/generated frequency to 30MHz.

Product : Intel® Dual Band Wireless-AC 8260  
 Test Item : General Radiated Emission Data  
 Test Site : No.3 OATS  
 Test Mode : Mode 2 SISO B: Transmit - 802.11n-20BW\_7.2Mbps(2.4G Band) (2437 MHz)

Frequency MHz	Correct Factor dB	Reading Level dBuV	Measurement Level dBuV/m	Margin dB	Limit dBuV/m
<b>Horizontal</b>					
210.420	-10.586	42.678	32.093	-11.407	43.500
336.520	-3.556	40.709	37.153	-8.847	46.000
449.040	0.241	38.091	38.332	-7.668	46.000
608.120	3.700	35.647	39.347	-6.653	46.000
771.080	4.905	34.634	39.539	-6.461	46.000
937.920	6.527	26.473	33.000	-13.000	46.000
<b>Vertical</b>					
225.940	-6.410	38.321	31.911	-14.089	46.000
392.780	-1.290	36.653	35.363	-10.637	46.000
505.300	-0.130	38.002	37.872	-8.128	46.000
672.140	-0.720	38.652	37.932	-8.068	46.000
804.060	3.120	36.469	39.589	-6.411	46.000
937.920	2.887	30.763	33.650	-12.350	46.000

Note:

1. All Readings below 1GHz are Quasi-Peak, above 1GHz are performed with peak and/or average measurements as necessary.
2. Peak measurements: RBW = 1MHz, VBW = 3 MHz, Sweep: Auto.
3. Average measurements: RBW = 1MHz, VBW = 10 Hz, Sweep: Auto.
4. Measurement Level = Reading Level + Correct Factor.
5. Correct Factor = Antenna factor + Cable loss – Amplifier gain.
6. The average measurement was not performed when the peak measured data under the limit of average detection.
7. The emission levels of other frequencies are very lower than the limit and not show in test report.
8. No emission found between lowest internal used/generated frequency to 30MHz.

Product : Intel® Dual Band Wireless-AC 8260  
 Test Item : General Radiated Emission Data  
 Test Site : No.3 OATS  
 Test Mode : Mode 2 SISO B: Transmit - 802.11n-40BW\_15Mbps(2.4G Band) (2437 MHz)

Frequency MHz	Correct Factor dB	Reading Level dBuV	Measurement Level dBuV/m	Margin dB	Limit dBuV/m
<b>Horizontal</b>					
214.300	-10.488	41.144	30.655	-12.845	43.500
359.800	-0.350	36.908	36.559	-9.441	46.000
524.700	2.950	34.813	37.763	-8.237	46.000
679.900	2.658	35.304	37.962	-8.038	46.000
821.520	6.845	30.944	37.789	-8.211	46.000
941.800	6.570	27.498	34.068	-11.932	46.000
<b>Vertical</b>					
200.720	-5.850	37.638	31.788	-11.712	43.500
299.660	-4.270	39.599	35.329	-10.671	46.000
462.620	-2.723	41.190	38.467	-7.533	46.000
606.180	2.020	36.584	38.604	-7.396	46.000
782.720	2.524	34.910	37.434	-8.566	46.000
943.740	3.170	29.335	32.505	-13.495	46.000

Note:

1. All Readings below 1GHz are Quasi-Peak, above 1GHz are performed with peak and/or average measurements as necessary.
2. Peak measurements: RBW = 1MHz, VBW = 3 MHz, Sweep: Auto.
3. Average measurements: RBW = 1MHz, VBW = 10 Hz, Sweep: Auto.
4. Measurement Level = Reading Level + Correct Factor.
5. Correct Factor = Antenna factor + Cable loss – Amplifier gain.
6. The average measurement was not performed when the peak measured data under the limit of average detection.
7. The emission levels of other frequencies are very lower than the limit and not show in test report.
8. No emission found between lowest internal used/generated frequency to 30MHz.

Product : Intel® Dual Band Wireless-AC 8260  
 Test Item : General Radiated Emission Data  
 Test Site : No.3 OATS  
 Test Mode : Mode 2 SISO B: Transmit - 802.11n-20BW\_7.2Mbps(5G Band) (5785 MHz)

Frequency MHz	Correct Factor dB	Reading Level dBuV	Measurement Level dBuV/m	Margin dB	Limit dBuV/m
<b>Horizontal</b>					
187.140	-11.380	41.191	29.811	-13.689	43.500
291.900	-5.396	41.117	35.721	-10.279	46.000
418.000	-0.328	37.314	36.987	-9.013	46.000
594.540	3.321	36.535	39.856	-6.144	46.000
765.260	4.876	34.371	39.247	-6.753	46.000
941.800	6.570	27.199	33.769	-12.231	46.000
<b>Vertical</b>					
216.240	-6.206	38.377	32.171	-13.829	46.000
363.680	-0.036	39.008	38.972	-7.028	46.000
547.980	0.030	38.648	38.678	-7.322	46.000
683.780	1.841	36.376	38.217	-7.783	46.000
829.280	2.091	35.990	38.081	-7.919	46.000
941.800	3.240	30.357	33.597	-12.403	46.000

Note:

1. All Readings below 1GHz are Quasi-Peak, above 1GHz are performed with peak and/or average measurements as necessary.
2. Peak measurements: RBW = 1MHz, VBW = 3 MHz, Sweep: Auto.
3. Average measurements: RBW = 1MHz, VBW = 10 Hz, Sweep: Auto.
4. Measurement Level = Reading Level + Correct Factor.
5. Correct Factor = Antenna factor + Cable loss – Amplifier gain.
6. The average measurement was not performed when the peak measured data under the limit of average detection.
7. The emission levels of other frequencies are very lower than the limit and not show in test report.
8. No emission found between lowest internal used/generated frequency to 30MHz.

Product : Intel® Dual Band Wireless-AC 8260  
 Test Item : General Radiated Emission Data  
 Test Site : No.3 OATS  
 Test Mode : Mode 2 SISO B: Transmit - 802.11n-40BW\_15Mbps(5G Band) (5755MHz)

Frequency MHz	Correct Factor dB	Reading Level dBuV	Measurement Level dBuV/m	Margin dB	Limit dBuV/m
<b>Horizontal</b>					
214.300	-10.488	41.144	30.655	-12.845	43.500
359.800	-0.350	36.908	36.559	-9.441	46.000
524.700	2.950	34.813	37.763	-8.237	46.000
679.900	2.658	35.304	37.962	-8.038	46.000
821.520	6.845	30.944	37.789	-8.211	46.000
941.800	6.570	27.498	34.068	-11.932	46.000
<b>Vertical</b>					
200.720	-5.850	37.638	31.788	-11.712	43.500
299.660	-4.270	39.599	35.329	-10.671	46.000
462.620	-2.723	41.190	38.467	-7.533	46.000
606.180	2.020	36.584	38.604	-7.396	46.000
782.720	2.524	34.910	37.434	-8.566	46.000
943.740	3.170	29.335	32.505	-13.495	46.000

Note:

1. All Readings below 1GHz are Quasi-Peak, above 1GHz are performed with peak and/or average measurements as necessary.
2. Peak measurements: RBW = 1MHz, VBW = 3 MHz, Sweep: Auto.
3. Average measurements: RBW = 1MHz, VBW = 10 Hz, Sweep: Auto.
4. Measurement Level = Reading Level + Correct Factor.
5. Correct Factor = Antenna factor + Cable loss – Amplifier gain.
6. The average measurement was not performed when the peak measured data under the limit of average detection.
7. The emission levels of other frequencies are very lower than the limit and not show in test report.
8. No emission found between lowest internal used/generated frequency to 30MHz.



Product : Intel® Dual Band Wireless-AC 8260  
 Test Item : General Radiated Emission Data  
 Test Site : No.3 OATS  
 Test Mode : Mode 2 SISO B: Transmit - 802.11ac-80BW\_32.5Mbps(5G Band) (5775MHz)

Frequency MHz	Correct Factor dB	Reading Level dBuV	Measurement Level dBuV/m	Margin dB	Limit dBuV/m
<b>Horizontal</b>					
204.600	-10.664	43.411	32.747	-10.753	43.500
336.520	-3.556	38.415	34.859	-11.141	46.000
454.860	1.611	35.983	37.594	-8.406	46.000
602.300	3.560	35.002	38.562	-7.438	46.000
736.160	2.798	34.571	37.369	-8.631	46.000
920.460	6.542	25.539	32.081	-13.919	46.000
<b>Vertical</b>					
206.540	-5.676	39.558	33.882	-9.618	43.500
330.700	-2.408	40.692	38.284	-7.716	46.000
482.020	-3.218	41.428	38.210	-7.790	46.000
615.880	1.263	37.844	39.107	-6.893	46.000
767.200	1.982	36.033	38.015	-7.985	46.000
930.160	3.591	29.042	32.633	-13.367	46.000

Note:

1. All Readings below 1GHz are Quasi-Peak, above 1GHz are performed with peak and/or average measurements as necessary.
2. Peak measurements: RBW = 1MHz, VBW = 3 MHz, Sweep: Auto.
3. Average measurements: RBW = 1MHz, VBW = 10 Hz, Sweep: Auto.
4. Measurement Level = Reading Level + Correct Factor.
5. Correct Factor = Antenna factor + Cable loss –Amplifier gain.
6. The average measurement was not performed when the peak measured data under the limit of average detection.
7. The emission levels of other frequencies are very lower than the limit and not show in test report.
8. No emission found between lowest internal used/generated frequency to 30MHz.

Product : Intel® Dual Band Wireless-AC 8260  
 Test Item : General Radiated Emission Data  
 Test Site : No.3 OATS  
 Test Mode : Mode 3 MIMO: Transmit - 802.11n-20BW\_14.4Mbps(2.4G Band) (2437 MHz)

Frequency MHz	Correct Factor dB	Reading Level dBuV	Measurement Level dBuV/m	Margin dB	Limit dBuV/m
<b>Horizontal</b>					
218.180	-10.376	40.798	30.422	-15.578	46.000
340.400	-3.385	37.835	34.450	-11.550	46.000
452.920	1.144	37.204	38.348	-7.652	46.000
617.820	2.229	35.372	37.601	-8.399	46.000
773.020	4.922	32.952	37.874	-8.126	46.000
932.100	7.037	26.259	33.296	-12.704	46.000
<b>Vertical</b>					
220.120	-6.690	36.760	30.070	-15.930	46.000
340.400	-1.435	37.910	36.475	-9.525	46.000
493.660	-1.829	37.953	36.124	-9.876	46.000
625.580	0.105	36.395	36.500	-9.500	46.000
780.780	2.538	34.601	37.139	-8.861	46.000
945.680	3.090	28.121	31.211	-14.789	46.000

Note:

1. All Readings below 1GHz are Quasi-Peak, above 1GHz are performed with peak and/or average measurements as necessary.
2. Peak measurements: RBW = 1MHz, VBW = 3 MHz, Sweep: Auto.
3. Average measurements: RBW = 1MHz, VBW = 10 Hz, Sweep: Auto.
4. Measurement Level = Reading Level + Correct Factor.
5. Correct Factor = Antenna factor + Cable loss – Amplifier gain.
6. The average measurement was not performed when the peak measured data under the limit of average detection.
7. The emission levels of other frequencies are very lower than the limit and not show in test report.
8. No emission found between lowest internal used/generated frequency to 30MHz.

Product : Intel® Dual Band Wireless-AC 8260  
 Test Item : General Radiated Emission Data  
 Test Site : No.3 OATS  
 Test Mode : Mode 3 MIMO: Transmit - 802.11n-40BW\_30Mbps(2.4G Band) (2437 MHz)

Frequency MHz	Correct Factor dB	Reading Level dBuV	Measurement Level dBuV/m	Margin dB	Limit dBuV/m
<b>Horizontal</b>					
225.940	-9.790	40.592	30.802	-15.198	46.000
357.860	-0.846	35.464	34.618	-11.382	46.000
493.660	1.301	36.652	37.953	-8.047	46.000
633.340	1.350	37.456	38.806	-7.194	46.000
769.140	4.899	33.095	37.994	-8.006	46.000
934.040	6.726	27.351	34.077	-11.923	46.000
<b>Vertical</b>					
196.840	-5.860	37.038	31.178	-12.322	43.500
309.360	-4.249	37.923	33.674	-12.326	46.000
460.680	-2.080	39.285	37.205	-8.795	46.000
610.060	1.863	35.362	37.225	-8.775	46.000
773.020	2.182	35.375	37.557	-8.443	46.000
932.100	3.197	29.008	32.205	-13.795	46.000

Note:

1. All Readings below 1GHz are Quasi-Peak, above 1GHz are performed with peak and/or average measurements as necessary.
2. Peak measurements: RBW = 1MHz, VBW = 3 MHz, Sweep: Auto.
3. Average measurements: RBW = 1MHz, VBW = 10 Hz, Sweep: Auto.
4. Measurement Level = Reading Level + Correct Factor.
5. Correct Factor = Antenna factor + Cable loss – Amplifier gain.
6. The average measurement was not performed when the peak measured data under the limit of average detection.
7. The emission levels of other frequencies are very lower than the limit and not show in test report.
8. No emission found between lowest internal used/generated frequency to 30MHz.

Product : Intel® Dual Band Wireless-AC 8260  
 Test Item : General Radiated Emission Data  
 Test Site : No.3 OATS  
 Test Mode : Mode 3 MIMO: Transmit - 802.11n-20BW\_14.4Mbps(5G Band) (5785 MHz)

Frequency MHz	Correct Factor dB	Reading Level dBuV	Measurement Level dBuV/m	Margin dB	Limit dBuV/m
<b>Horizontal</b>					
212.360	-10.540	41.031	30.491	-13.009	43.500
352.040	-1.412	35.882	34.471	-11.529	46.000
464.560	2.760	34.445	37.205	-8.795	46.000
612.000	3.180	35.378	38.558	-7.442	46.000
778.840	4.951	33.045	37.996	-8.004	46.000
928.220	6.990	24.282	31.272	-14.728	46.000
<b>Vertical</b>					
204.600	-5.644	36.832	31.188	-12.312	43.500
340.400	-1.435	36.393	34.958	-11.042	46.000
462.620	-2.723	39.274	36.551	-9.449	46.000
610.060	1.863	36.483	38.346	-7.654	46.000
796.300	2.400	35.572	37.972	-8.028	46.000
926.280	3.102	28.949	32.051	-13.949	46.000

Note:

1. All Readings below 1GHz are Quasi-Peak, above 1GHz are performed with peak and/or average measurements as necessary.
2. Peak measurements: RBW = 1MHz, VBW = 3 MHz, Sweep: Auto.
3. Average measurements: RBW = 1MHz, VBW = 10 Hz, Sweep: Auto.
4. Measurement Level = Reading Level + Correct Factor.
5. Correct Factor = Antenna factor + Cable loss – Amplifier gain.
6. The average measurement was not performed when the peak measured data under the limit of average detection.
7. The emission levels of other frequencies are very lower than the limit and not show in test report.
8. No emission found between lowest internal used/generated frequency to 30MHz.

Product : Intel® Dual Band Wireless-AC 8260  
 Test Item : General Radiated Emission Data  
 Test Site : No.3 OATS  
 Test Mode : Mode 3 MIMO: Transmit - 802.11n-40BW\_30Mbps(5G Band) (5755MHz)

Frequency MHz	Correct Factor dB	Reading Level dBuV	Measurement Level dBuV/m	Margin dB	Limit dBuV/m
<b>Horizontal</b>					
202.660	-10.358	41.897	31.540	-11.960	43.500
334.580	-3.684	39.427	35.743	-10.257	46.000
423.820	-0.334	37.964	37.630	-8.370	46.000
590.660	3.100	35.718	38.818	-7.182	46.000
757.500	4.899	31.986	36.885	-9.115	46.000
943.740	6.630	25.320	31.950	-14.050	46.000
<b>Vertical</b>					
212.360	-5.910	36.679	30.769	-12.731	43.500
291.900	-5.466	40.070	34.604	-11.396	46.000
414.120	-5.930	42.687	36.757	-9.243	46.000
542.160	1.658	35.769	37.428	-8.572	46.000
761.380	1.713	37.397	39.110	-6.890	46.000
957.320	2.810	32.803	35.613	-10.387	46.000

Note:

1. All Readings below 1GHz are Quasi-Peak, above 1GHz are performed with peak and/or average measurements as necessary.
2. Peak measurements: RBW = 1MHz, VBW = 3 MHz, Sweep: Auto.
3. Average measurements: RBW = 1MHz, VBW = 10 Hz, Sweep: Auto.
4. Measurement Level = Reading Level + Correct Factor.
5. Correct Factor = Antenna factor + Cable loss – Amplifier gain.
6. The average measurement was not performed when the peak measured data under the limit of average detection.
7. The emission levels of other frequencies are very lower than the limit and not show in test report.
8. No emission found between lowest internal used/generated frequency to 30MHz.

Product : Intel® Dual Band Wireless-AC 8260  
 Test Item : General Radiated Emission Data  
 Test Site : No.3 OATS  
 Test Mode : Mode 3 MIMO: Transmit - 802.11ac-80BW\_65Mbps(5G Band) (5775MHz)

Frequency MHz	Correct Factor dB	Reading Level dBuV	Measurement Level dBuV/m	Margin dB	Limit dBuV/m
<b>Horizontal</b>					
218.180	-10.376	42.381	32.005	-13.995	46.000
353.980	-1.400	38.091	36.691	-9.309	46.000
489.780	1.326	36.799	38.125	-7.875	46.000
600.360	3.240	33.896	37.136	-8.864	46.000
728.400	3.652	34.734	38.386	-7.614	46.000
910.760	6.220	29.705	35.925	-10.075	46.000
<b>Vertical</b>					
216.240	-6.206	37.516	31.310	-14.690	46.000
319.060	-4.327	39.761	35.434	-10.566	46.000
427.700	-8.270	45.877	37.607	-8.393	46.000
594.540	-0.059	37.651	37.592	-8.408	46.000
788.540	2.484	35.009	37.493	-8.507	46.000
941.800	3.240	28.868	32.108	-13.892	46.000

Note:

1. All Readings below 1GHz are Quasi-Peak, above 1GHz are performed with peak and/or average measurements as necessary.
2. Peak measurements: RBW = 1MHz, VBW = 3 MHz, Sweep: Auto.
3. Average measurements: RBW = 1MHz, VBW = 10 Hz, Sweep: Auto.
4. Measurement Level = Reading Level + Correct Factor.
5. Correct Factor = Antenna factor + Cable loss – Amplifier gain.
6. The average measurement was not performed when the peak measured data under the limit of average detection.
7. The emission levels of other frequencies are very lower than the limit and not show in test report.
8. No emission found between lowest internal used/generated frequency to 30MHz.

Product : Intel® Dual Band Wireless-AC 8260  
 Test Item : General Radiated Emission Data  
 Test Site : No.3 OATS  
 Test Mode : Mode 4 Beamforming: Transmit - 802.11n-20BW\_14.4Mbps(2.4G Band) (2437 MHz)

Frequency MHz	Correct Factor dB	Reading Level dBuV	Measurement Level dBuV/m	Margin dB	Limit dBuV/m
<b>Horizontal</b>					
200.720	-10.020	41.394	31.374	-12.126	43.500
352.040	-1.412	38.100	36.689	-9.311	46.000
493.660	1.301	36.169	37.470	-8.530	46.000
650.800	1.730	37.905	39.635	-6.365	46.000
800.180	6.173	31.881	38.054	-7.946	46.000
941.800	6.570	25.816	32.386	-13.614	46.000
<b>Vertical</b>					
229.820	-6.277	40.247	33.970	-12.030	46.000
365.620	0.170	37.922	38.092	-7.908	46.000
483.960	-2.812	39.928	37.116	-8.884	46.000
625.580	0.105	38.757	38.862	-7.138	46.000
811.820	2.590	35.492	38.082	-7.918	46.000
961.200	3.110	29.313	32.423	-21.577	54.000

Note:

1. All Readings below 1GHz are Quasi-Peak, above 1GHz are performed with peak and/or average measurements as necessary.
2. Peak measurements: RBW = 1MHz, VBW = 3 MHz, Sweep: Auto.
3. Average measurements: RBW = 1MHz, VBW = 10 Hz, Sweep: Auto.
4. Measurement Level = Reading Level + Correct Factor.
5. Correct Factor = Antenna factor + Cable loss – Amplifier gain.
6. The average measurement was not performed when the peak measured data under the limit of average detection.
7. The emission levels of other frequencies are very lower than the limit and not show in test report.
8. No emission found between lowest internal used/generated frequency to 30MHz.

Product : Intel® Dual Band Wireless-AC 8260  
 Test Item : General Radiated Emission Data  
 Test Site : No.3 OATS  
 Test Mode : Mode 4 Beamforming: Transmit - 802.11n-40BW\_30Mbps(2.4G Band) (2437 MHz)

Frequency MHz	Correct Factor dB	Reading Level dBuV	Measurement Level dBuV/m	Margin dB	Limit dBuV/m
<b>Horizontal</b>					
212.360	-10.540	41.794	31.254	-12.246	43.500
324.880	-4.687	40.312	35.625	-10.375	46.000
466.500	3.000	36.026	39.026	-6.974	46.000
602.300	3.560	35.686	39.246	-6.754	46.000
788.540	5.914	31.706	37.620	-8.380	46.000
932.100	7.037	29.256	36.293	-9.707	46.000
<b>Vertical</b>					
222.060	-6.626	39.262	32.635	-13.365	46.000
359.800	-1.440	38.468	37.029	-8.971	46.000
530.520	0.995	37.297	38.292	-7.708	46.000
658.560	-1.934	39.797	37.863	-8.137	46.000
773.020	2.182	34.976	37.158	-8.842	46.000
920.460	3.022	27.251	30.273	-15.727	46.000

Note:

1. All Readings below 1GHz are Quasi-Peak, above 1GHz are performed with peak and/or average measurements as necessary.
2. Peak measurements: RBW = 1MHz, VBW = 3 MHz, Sweep: Auto.
3. Average measurements: RBW = 1MHz, VBW = 10 Hz, Sweep: Auto.
4. Measurement Level = Reading Level + Correct Factor.
5. Correct Factor = Antenna factor + Cable loss – Amplifier gain.
6. The average measurement was not performed when the peak measured data under the limit of average detection.
7. The emission levels of other frequencies are very lower than the limit and not show in test report.
8. No emission found between lowest internal used/generated frequency to 30MHz.



Product : Intel® Dual Band Wireless-AC 8260  
 Test Item : General Radiated Emission Data  
 Test Site : No.3 OATS  
 Test Mode : Mode 4 Beamforming: Transmit - 802.11n-20BW\_14.4Mbps(5G Band) (5785 MHz)

Frequency MHz	Correct Factor dB	Reading Level dBuV	Measurement Level dBuV/m	Margin dB	Limit dBuV/m
<b>Horizontal</b>					
206.540	-10.696	42.469	31.773	-11.727	43.500
338.460	-3.532	40.092	36.559	-9.441	46.000
456.800	2.287	37.336	39.623	-6.377	46.000
604.240	4.056	35.651	39.708	-6.292	46.000
774.960	4.928	33.002	37.930	-8.070	46.000
949.560	6.824	25.081	31.905	-14.095	46.000
<b>Vertical</b>					
196.840	-5.860	38.940	33.080	-10.420	43.500
311.300	-4.273	40.975	36.702	-9.298	46.000
441.280	-6.970	44.148	37.178	-8.822	46.000
625.580	0.105	38.112	38.217	-7.783	46.000
811.820	2.590	36.751	39.341	-6.659	46.000
967.020	3.695	28.004	31.699	-22.301	54.000

Note:

1. All Readings below 1GHz are Quasi-Peak, above 1GHz are performed with peak and/or average measurements as necessary.
2. Peak measurements: RBW = 1MHz, VBW = 3 MHz, Sweep: Auto.
3. Average measurements: RBW = 1MHz, VBW = 10 Hz, Sweep: Auto.
4. Measurement Level = Reading Level + Correct Factor.
5. Correct Factor = Antenna factor + Cable loss – Amplifier gain.
6. The average measurement was not performed when the peak measured data under the limit of average detection.
7. The emission levels of other frequencies are very lower than the limit and not show in test report.
8. No emission found between lowest internal used/generated frequency to 30MHz.

Product : Intel® Dual Band Wireless-AC 8260  
 Test Item : General Radiated Emission Data  
 Test Site : No.3 OATS  
 Test Mode : Mode 4 Beamforming: Transmit - 802.11n-40BW\_30Mbps(5G Band) (5755MHz)

Frequency MHz	Correct Factor dB	Reading Level dBuV	Measurement Level dBuV/m	Margin dB	Limit dBuV/m
<b>Horizontal</b>					
212.360	-10.540	42.603	32.063	-11.437	43.500
359.800	-0.350	36.631	36.282	-9.718	46.000
458.740	3.150	36.467	39.617	-6.383	46.000
579.020	3.199	34.774	37.973	-8.027	46.000
724.520	3.650	34.624	38.274	-7.726	46.000
912.700	6.190	27.365	33.555	-12.445	46.000
<b>Vertical</b>					
198.780	-5.880	36.758	30.878	-12.622	43.500
313.240	-4.286	39.258	34.972	-11.028	46.000
476.200	-3.628	41.852	38.224	-7.776	46.000
625.580	0.105	36.940	37.045	-8.955	46.000
800.180	2.393	36.865	39.258	-6.742	46.000
937.920	2.887	28.414	31.301	-14.699	46.000

Note:

1. All Readings below 1GHz are Quasi-Peak, above 1GHz are performed with peak and/or average measurements as necessary.
2. Peak measurements: RBW = 1MHz, VBW = 3 MHz, Sweep: Auto.
3. Average measurements: RBW = 1MHz, VBW = 10 Hz, Sweep: Auto.
4. Measurement Level = Reading Level + Correct Factor.
5. Correct Factor = Antenna factor + Cable loss – Amplifier gain.
6. The average measurement was not performed when the peak measured data under the limit of average detection.
7. The emission levels of other frequencies are very lower than the limit and not show in test report.
8. No emission found between lowest internal used/generated frequency to 30MHz.

Product : Intel® Dual Band Wireless-AC 8260  
 Test Item : General Radiated Emission Data  
 Test Site : No.3 OATS  
 Test Mode : Mode 4 Beamforming: Transmit - 802.11ac-80BW\_65Mbps(5G Band) (5775MHz)

Frequency MHz	Correct Factor dB	Reading Level dBuV	Measurement Level dBuV/m	Margin dB	Limit dBuV/m
<b>Horizontal</b>					
210.420	-10.427	41.999	31.572	-11.928	43.500
346.220	-1.347	38.018	36.671	-9.329	46.000
482.020	1.664	37.483	39.147	-6.853	46.000
633.340	1.530	38.062	39.592	-6.408	46.000
769.140	5.118	31.841	36.959	-9.041	46.000
924.340	6.589	25.642	32.231	-13.769	46.000
<b>Vertical</b>					
218.180	-6.456	37.640	31.184	-14.816	46.000
346.220	-0.670	34.631	33.960	-12.040	46.000
462.620	-2.723	39.843	37.120	-8.880	46.000
621.700	0.142	37.801	37.943	-8.057	46.000
796.300	2.400	36.022	38.422	-7.578	46.000
951.500	2.873	28.604	31.477	-14.523	46.000

Note:

1. All Readings below 1GHz are Quasi-Peak, above 1GHz are performed with peak and/or average measurements as necessary.
2. Peak measurements: RBW = 1MHz, VBW = 3 MHz, Sweep: Auto.
3. Average measurements: RBW = 1MHz, VBW = 10 Hz, Sweep: Auto.
4. Measurement Level = Reading Level + Correct Factor.
5. Correct Factor = Antenna factor + Cable loss – Amplifier gain.
6. The average measurement was not performed when the peak measured data under the limit of average detection.
7. The emission levels of other frequencies are very lower than the limit and not show in test report.
8. No emission found between lowest internal used/generated frequency to 30MHz.

## 5. RF antenna conducted test

### 5.1. Test Equipment

	Equipment	Manufacturer	Model No./Serial No.	Last Cal.
X	Spectrum Analyzer	R&S	FSP40 / 100170	Jun, 2014
	Spectrum Analyzer	Agilent	E4407B / US39440758	Jun, 2014
	Spectrum Analyzer	Agilent	N9010A / MY48030495	Apr., 2015

- Note:
1. All equipments are calibrated with traceable calibrations. Each calibration is traceable to the national or international standards.
  2. The test instruments marked with “X” are used to measure the final test results.

### 5.2. Test Setup

#### RF antenna Conducted Measurement:

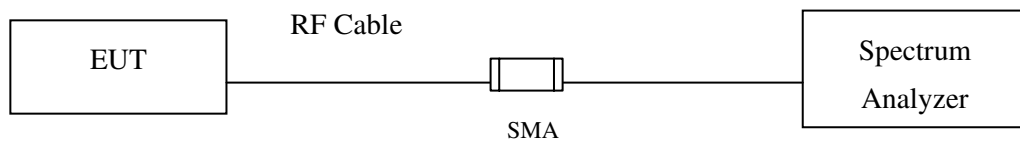

### 5.3. Limits

In any 100 kHz bandwidth outside the frequency band in which the spread spectrum intentional radiator is operating, the radio frequency power that is produced by the intentional radiator shall be at least 20 dB below that in the 100 kHz bandwidth within the band that contains the highest level of the desired power, based on either an RF conducted or a radiated measurement. Attenuation below the general limits specified in Section 15.209(a) is not required. In addition, radiated emissions which fall in the restricted bands, as defined in Section 15.205(a), must also comply with the radiated emission limits specified in Section 15.209(a) (see Section 15.205(c)).

Note: Channel 5775 MHz was tested using the procedure in KDB 558074, section 9.2.2.2.

Non-restricted frequency bands must comply with the KDB 558074, section 11.1 b) requirement.

#### **5.4. Test Procedure**

The EUT was tested according to DTS test procedure of KDB558074 for compliance to FCC 47CFR 15.247 requirements.

Set RBW = 100 kHz, Set VBW  $\geq 3 \times$  RBW, scan up through 10th harmonic.

#### **5.5. Uncertainty**

The measurement uncertainty

Conducted is defined as  $\pm 1.27\text{dB}$

**5.6. Test Result of RF antenna conducted test**

Product : Intel® Dual Band Wireless-AC 8260  
 Test Item : RF antenna conducted test  
 Test Site : No.3 OATS  
 Test Mode : Mode 1 SISO A: Transmit (802.11b 1Mbps)

**Channel 01 (2412MHz) 30MHz-25GHz**

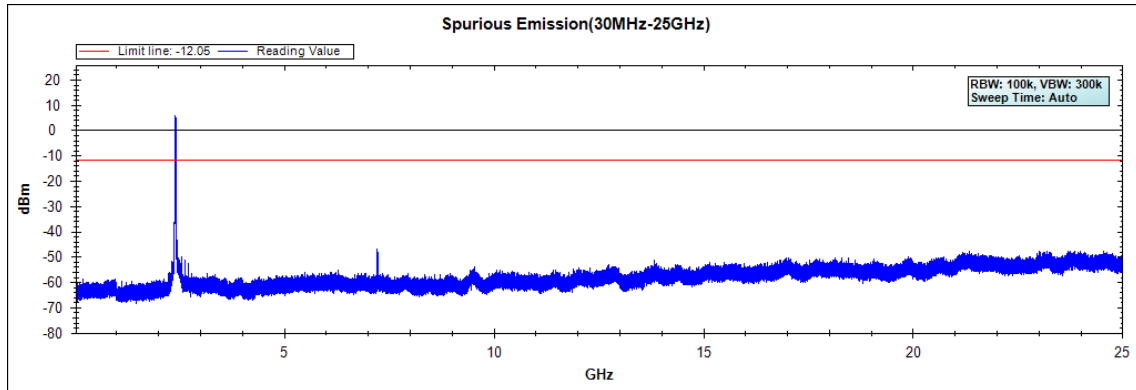

**Channel 06 (2437MHz) 30MHz -25GHz**

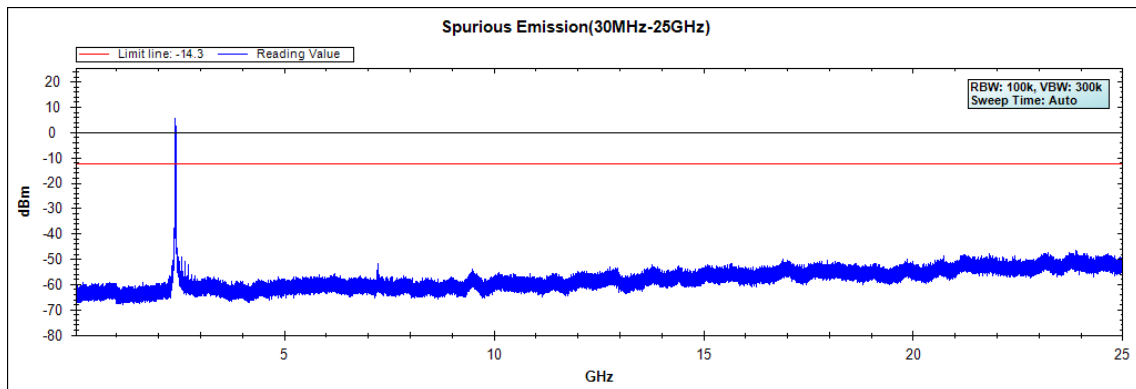

**Channel 11 (2462MHz) 30MHz -25GHz**

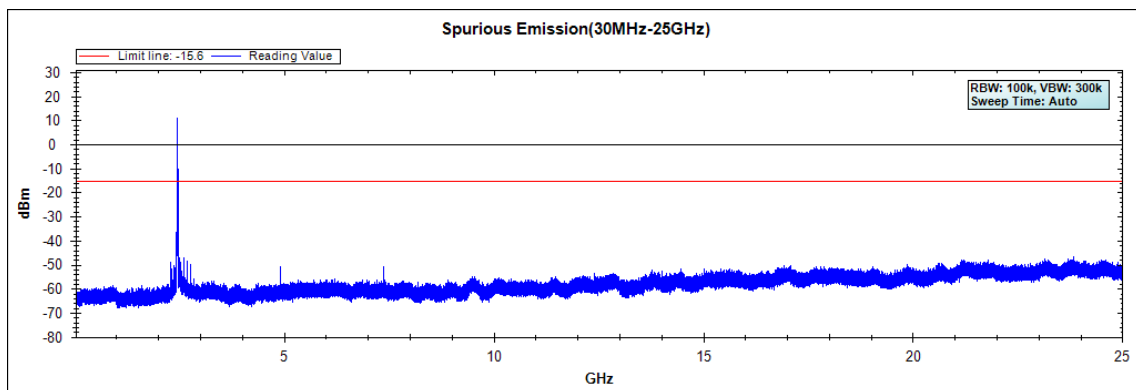

Channel 12 (2467MHz) 30MHz -25GHz

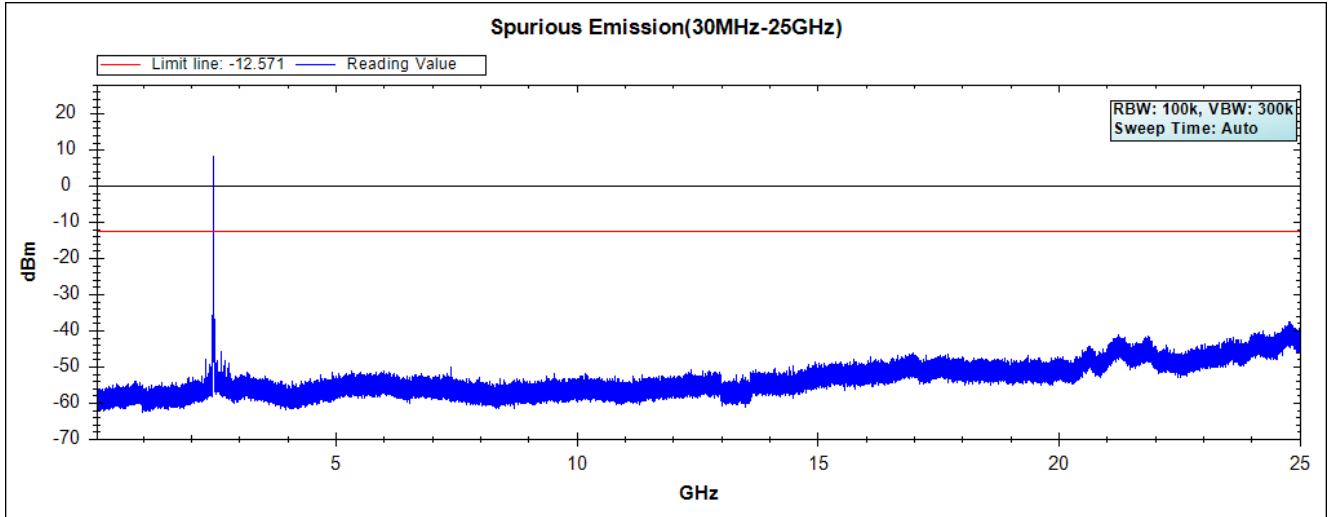

Note: The above test pattern is synthesized by multiple of the frequency range.

Product : Intel® Dual Band Wireless-AC 8260  
Test Item : RF Antenna Conducted Spurious  
Test Site : No.3 OATS  
Test Mode : Mode 1 SISO A: Transmit (802.11g 6Mbps)

**Channel 01 (2412MHz) 30MHz -25GHz**

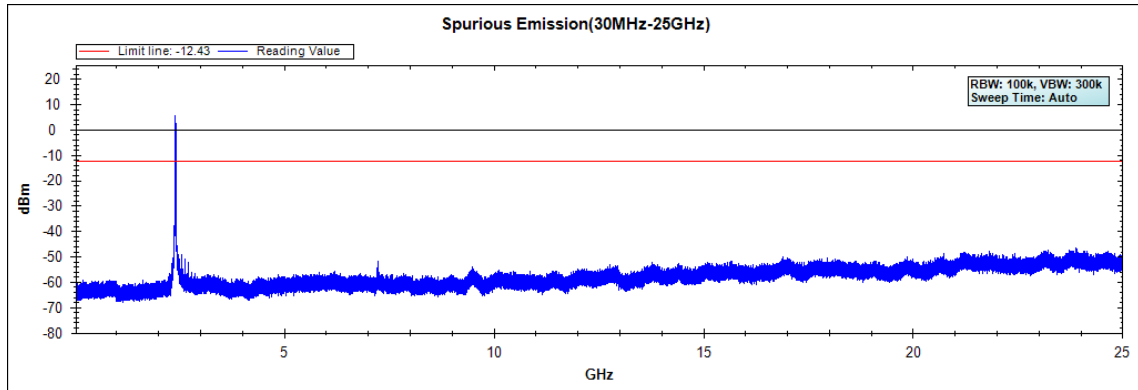

**Channel 06 (2437MHz) 30MHz -25GHz**

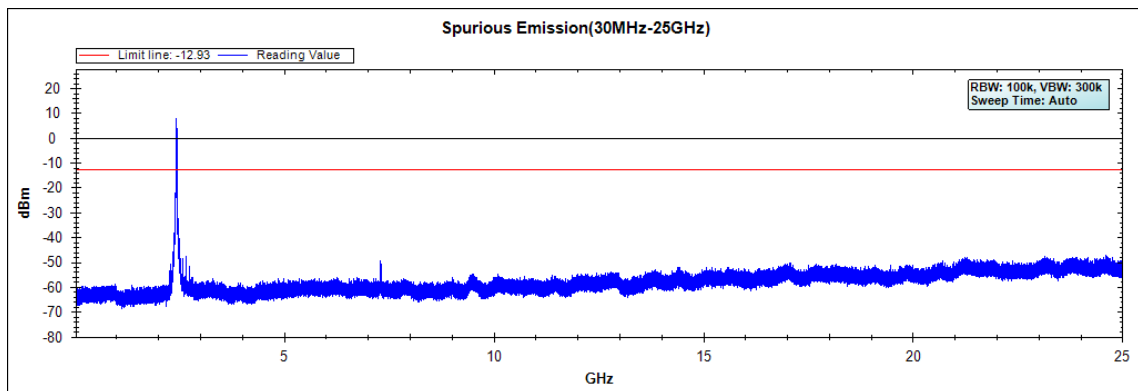

**Channel 11 (2462MHz) 30MHz -25GHz**

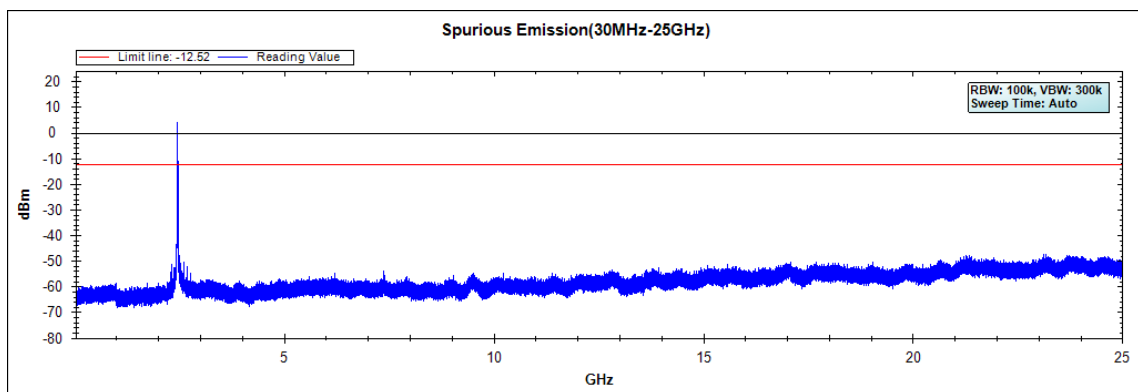



Channel 12 (2467MHz) 30MHz -25GHz

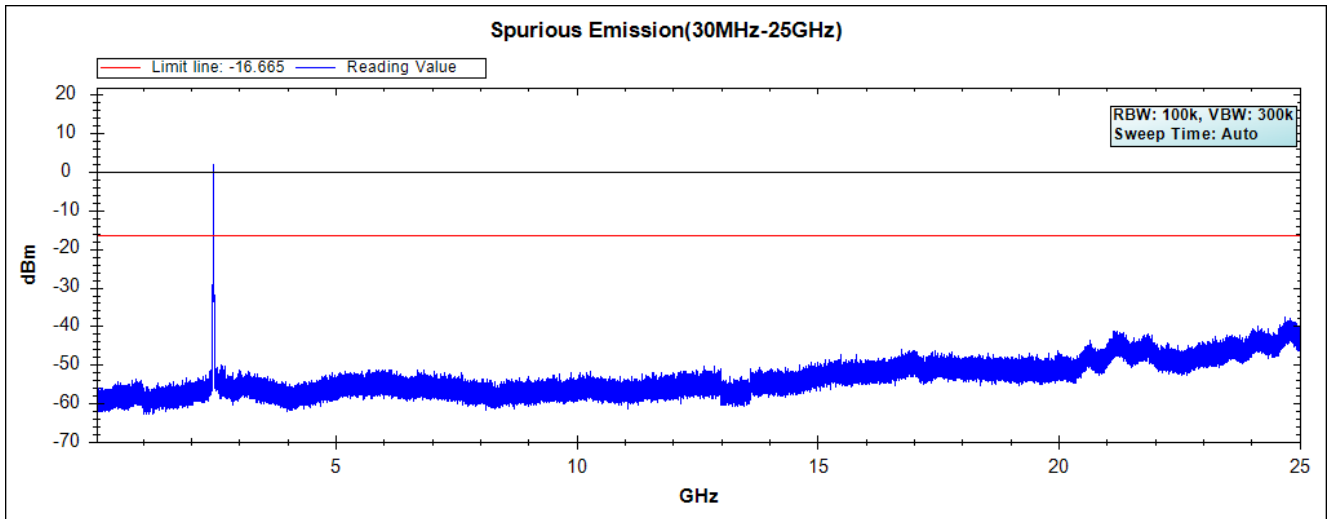

Note: The above test pattern is synthesized by multiple of the frequency range.

Product : Intel® Dual Band Wireless-AC 8260  
 Test Item : RF Antenna Conducted Spurious  
 Test Site : No.3 OATS  
 Test Mode : Mode 1 SISO A: Transmit - 802.11a 6Mbps

**Channel 149 (5745MHz) 30MHz -40GHz**

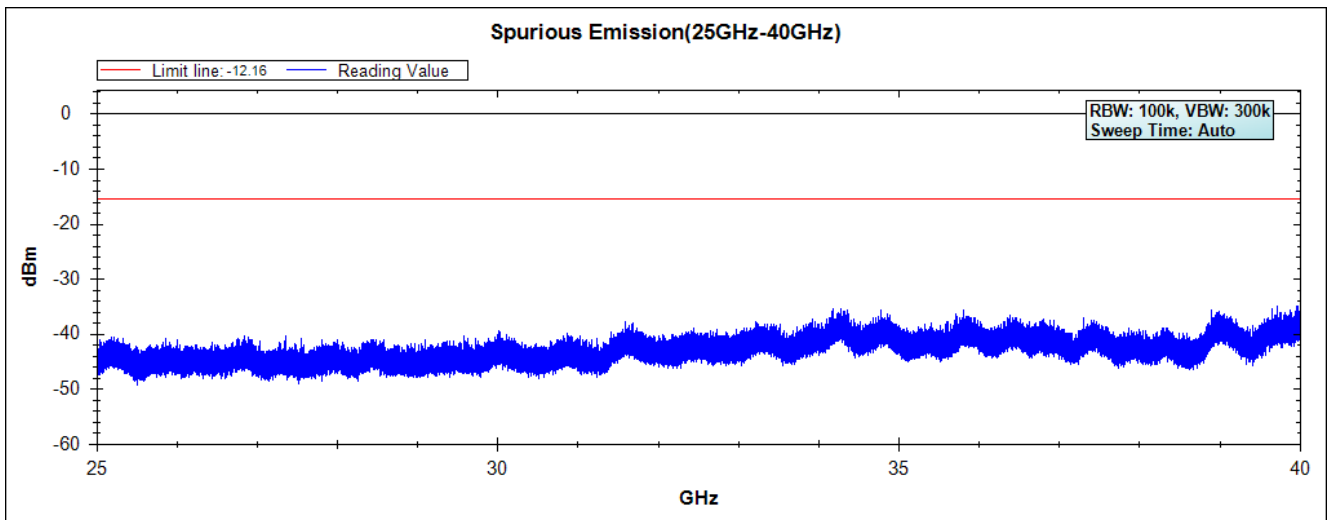
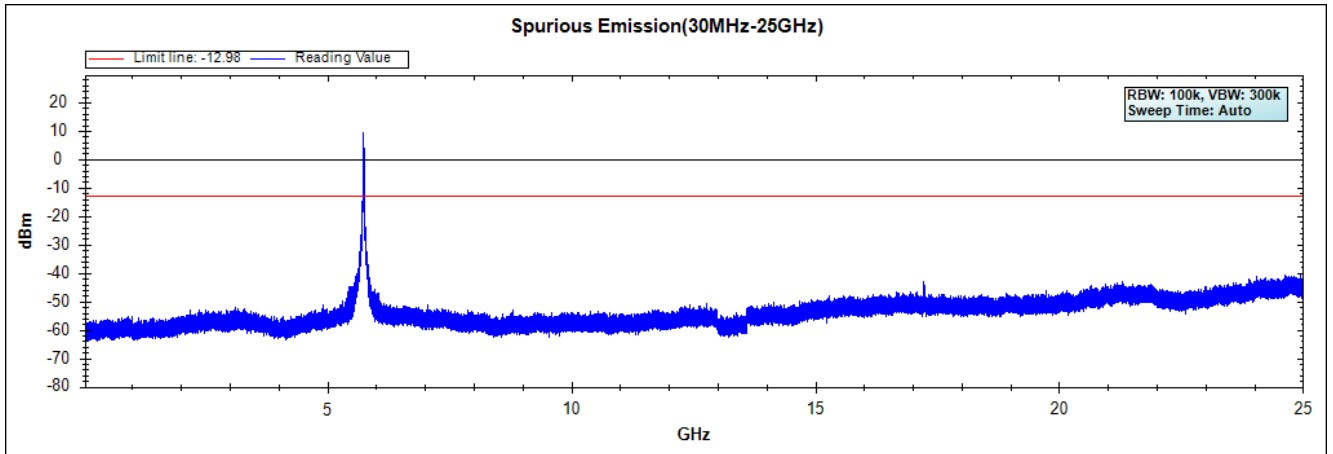

Note: The above test pattern is synthesized by multiple of the frequency range.

Channel 157 (5785MHz) 30MHz -40GHz

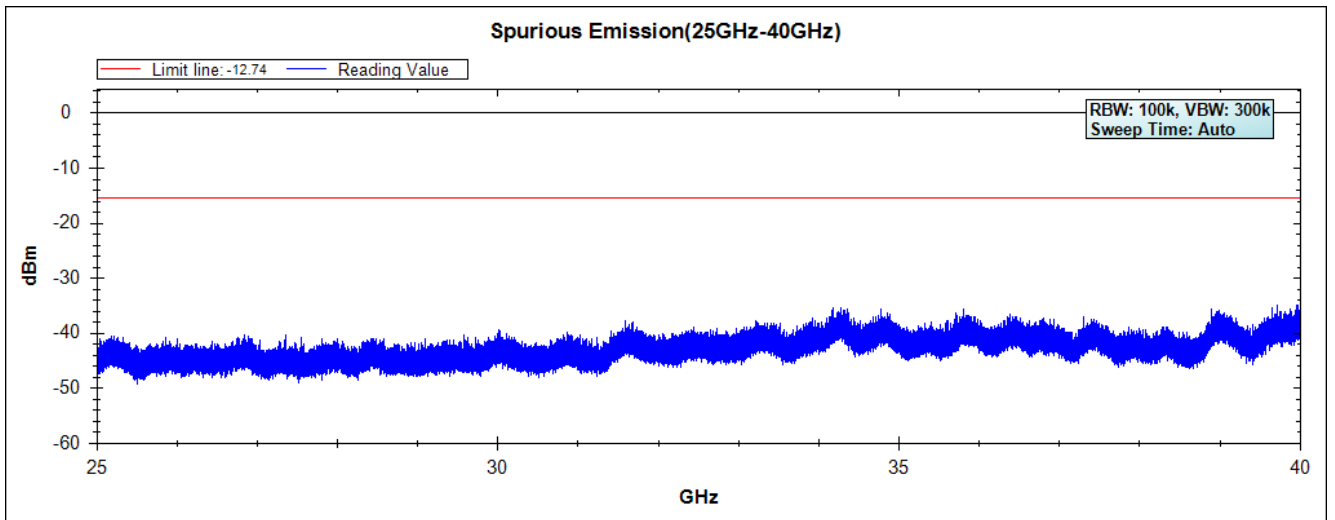
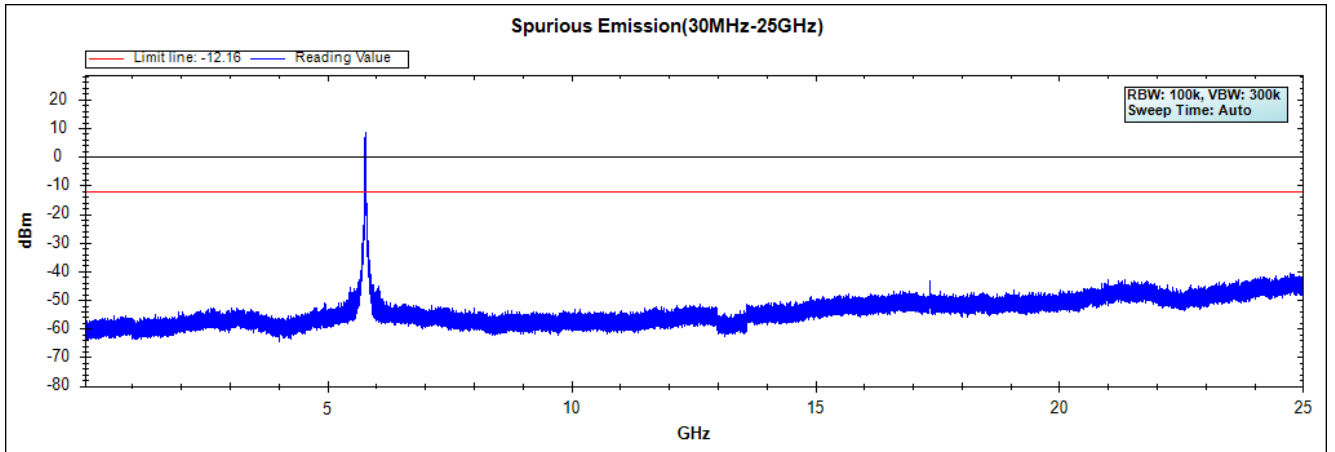

Note: The above test pattern is synthesized by multiple of the frequency range.

Channel 165 (5825MHz) 30MHz -40GHz

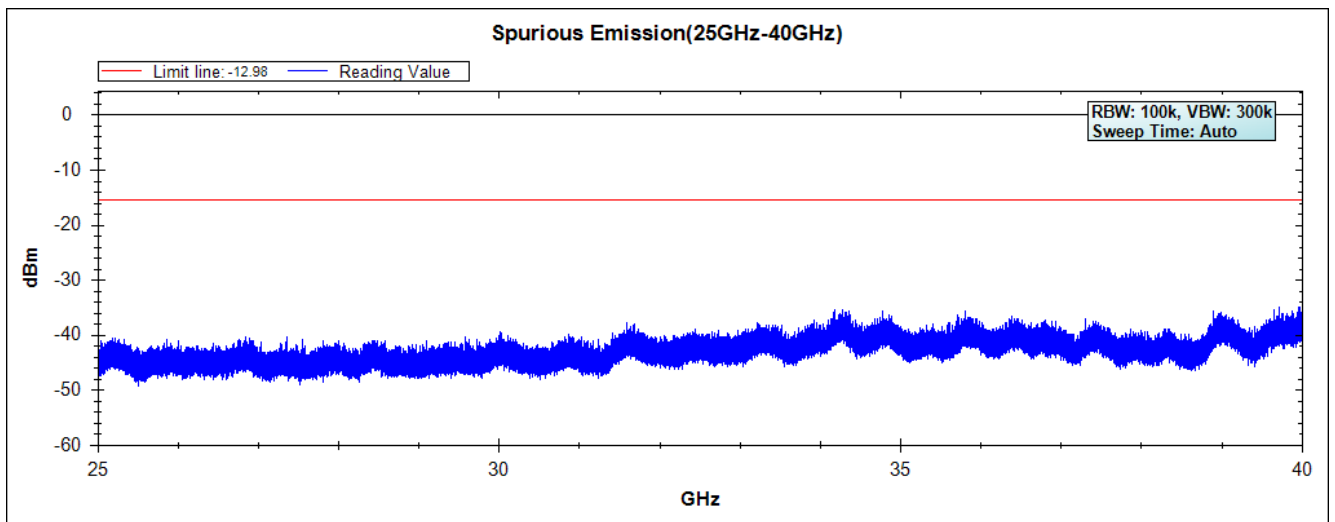
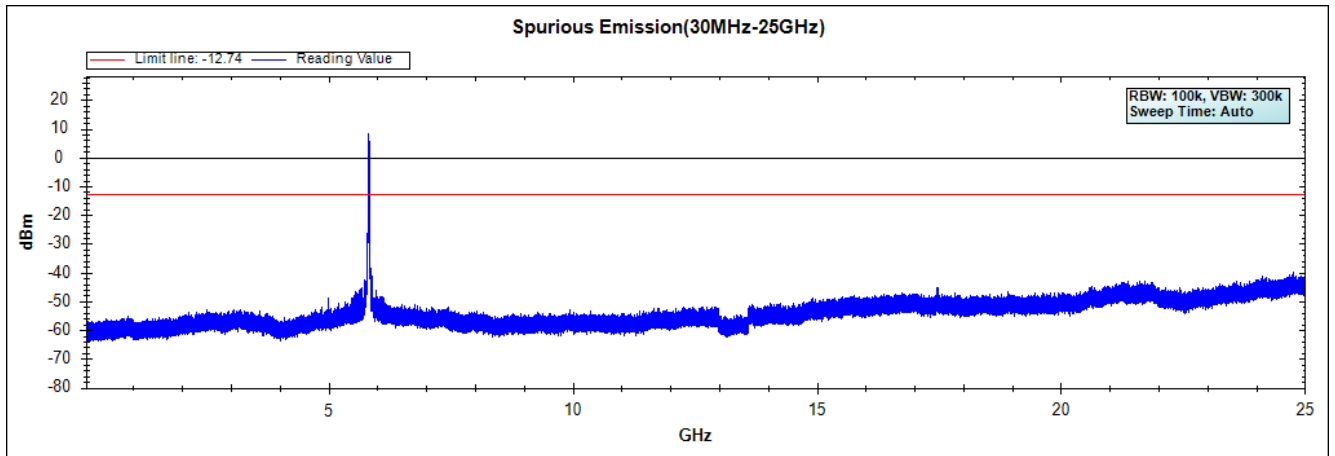

Note: The above test pattern is synthesized by multiple of the frequency range.

Product : Intel® Dual Band Wireless-AC 8260  
Test Item : RF Antenna Conducted Spurious  
Test Site : No.3 OATS  
Test Mode : Mode 1 SISO A: Transmit - 802.11n-20BW\_7.2Mbps(2.4G Band)

**Channel 01 (2412MHz) 30MHz -25GHz**

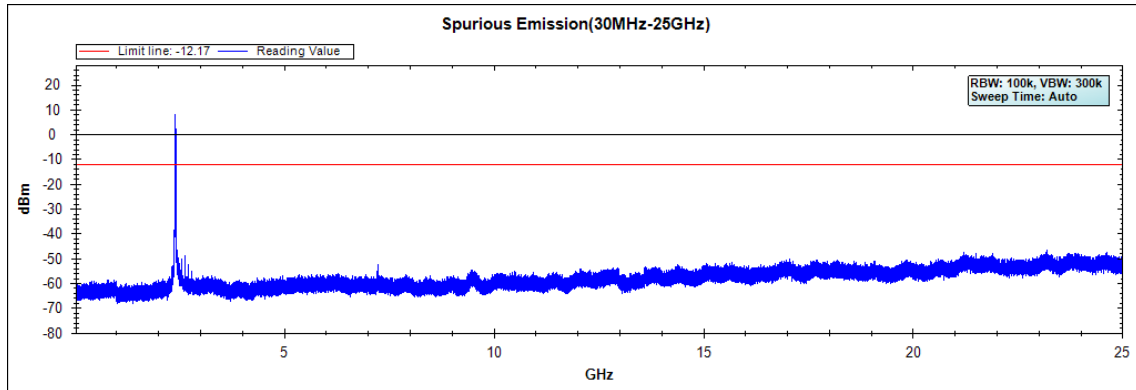

**Channel 06 (2437MHz) 30MHz -25GHz**

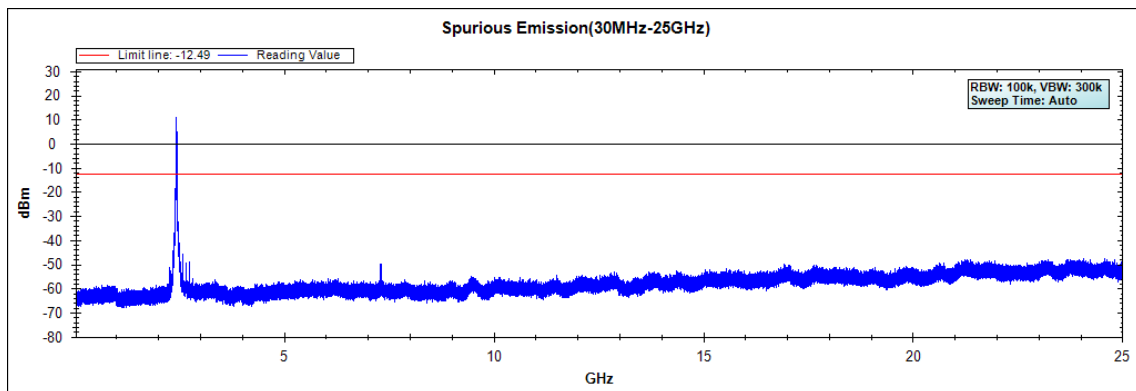

**Channel 11 (2462MHz) 30MHz -25GHz**

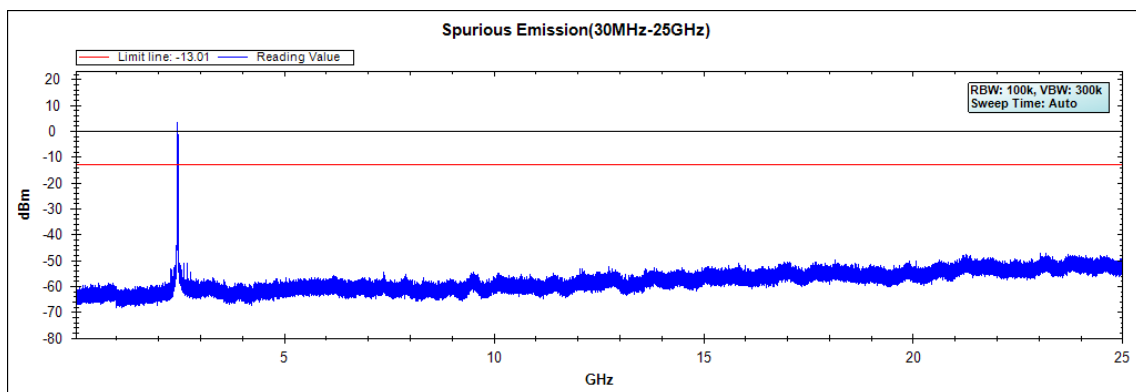

Channel 12 (2467MHz) 30MHz -25GHz

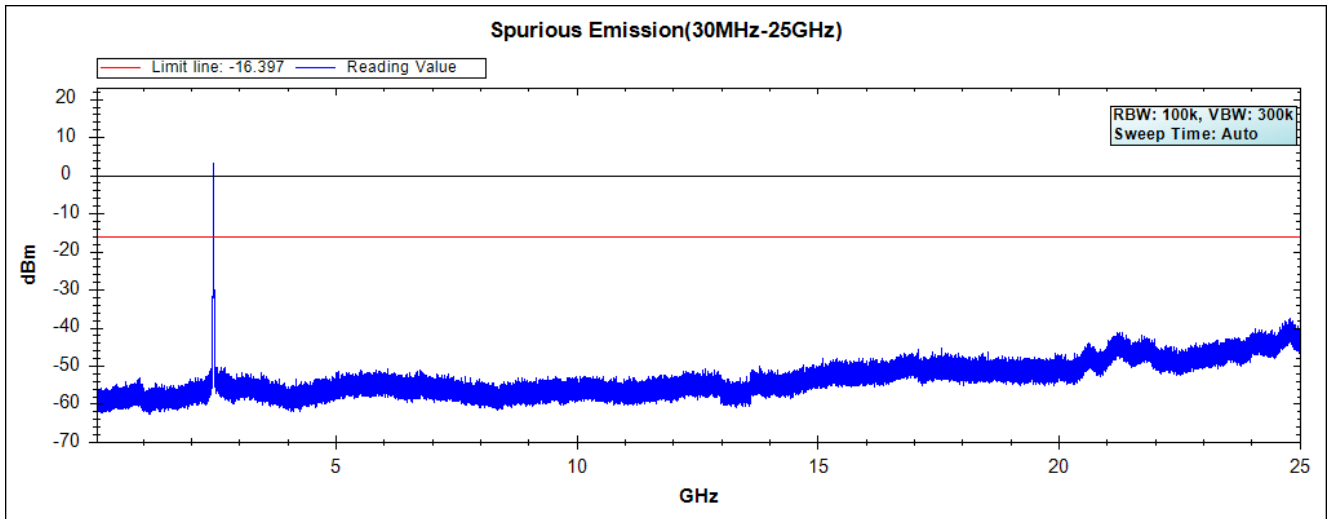

Note: The above test pattern is synthesized by multiple of the frequency range.

Product : Intel® Dual Band Wireless-AC 8260  
 Test Item : RF Antenna Conducted Spurious  
 Test Site : No.3 OATS  
 Test Mode : Mode 1 SISO A: Transmit - 802.11n-40BW\_15Mbps(2.4G Band)

**Channel 03 (2422MHz) 30MHz -25GHz**

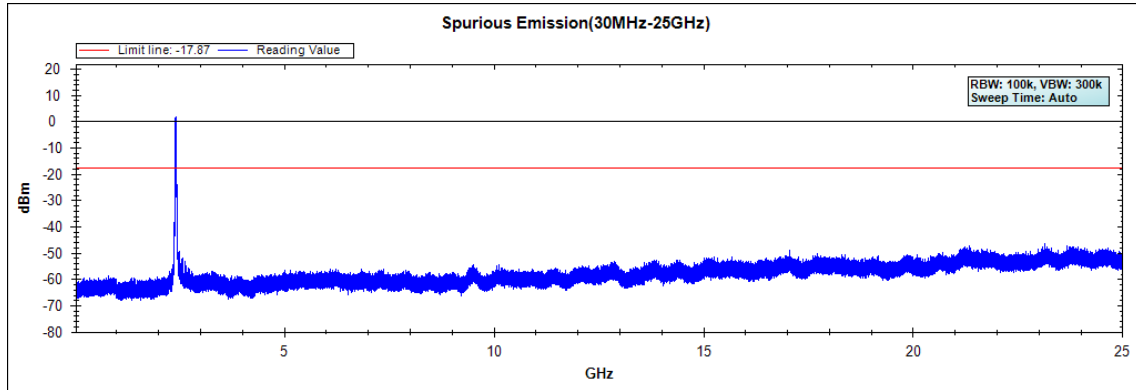

**Channel 06 (2437MHz) 30MHz -25GHz**

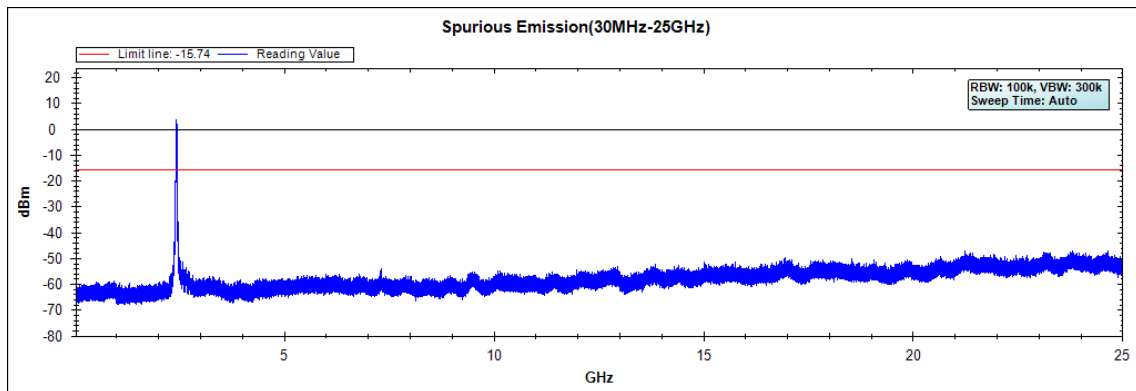

**Channel 09 (2452MHz) 30MHz -25GHz**

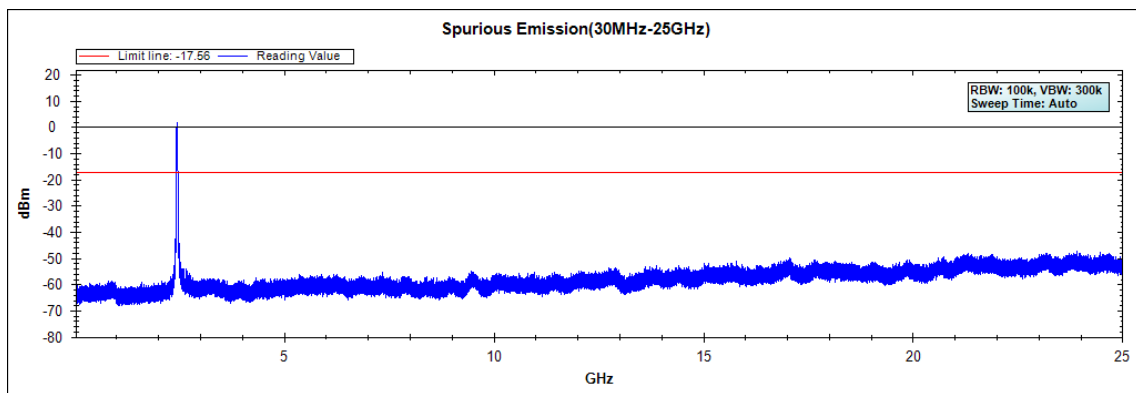

Channel 10 (2457MHz) 30MHz -25GHz

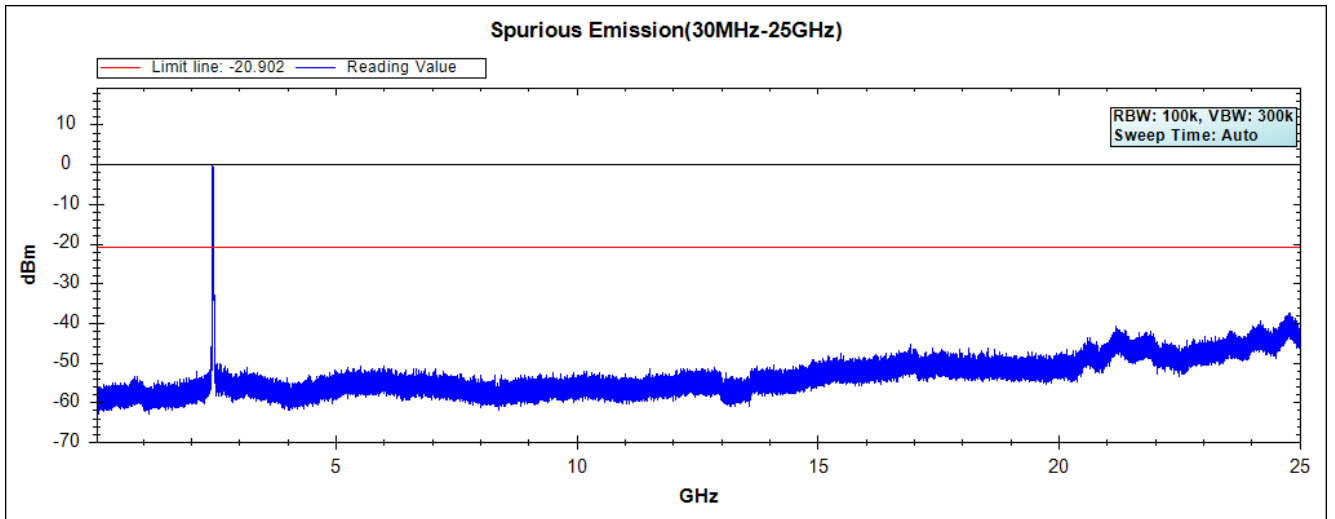

Note: The above test pattern is synthesized by multiple of the frequency range.



Product : Intel® Dual Band Wireless-AC 8260  
 Test Item : RF Antenna Conducted Spurious  
 Test Site : No.3 OATS  
 Test Mode : Mode 1 SISO A: Transmit - 802.11n-20BW\_7.2Mbps(5G Band)

**Channel 49 (5745MHz) 30MHz -40GHz**

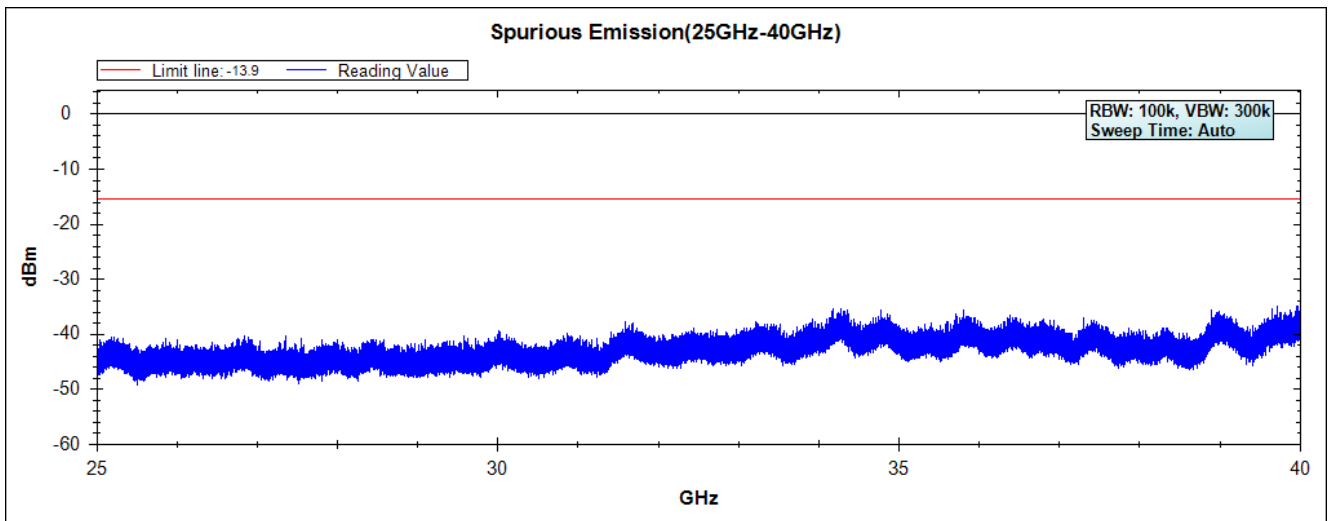
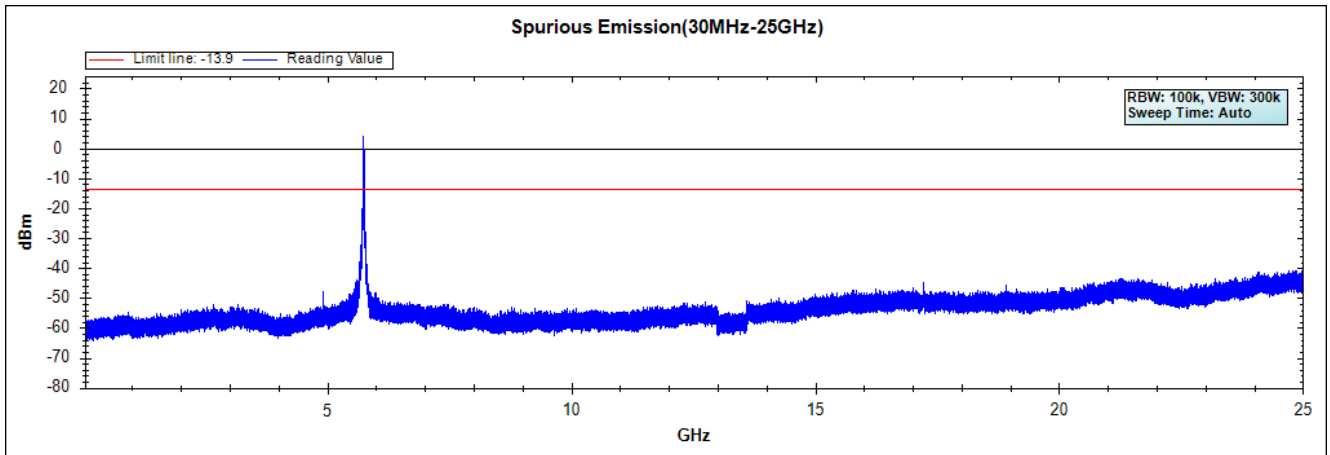

Note: The above test pattern is synthesized by multiple of the frequency range

Channel 157 (5785MHz) 30MHz -40GHz

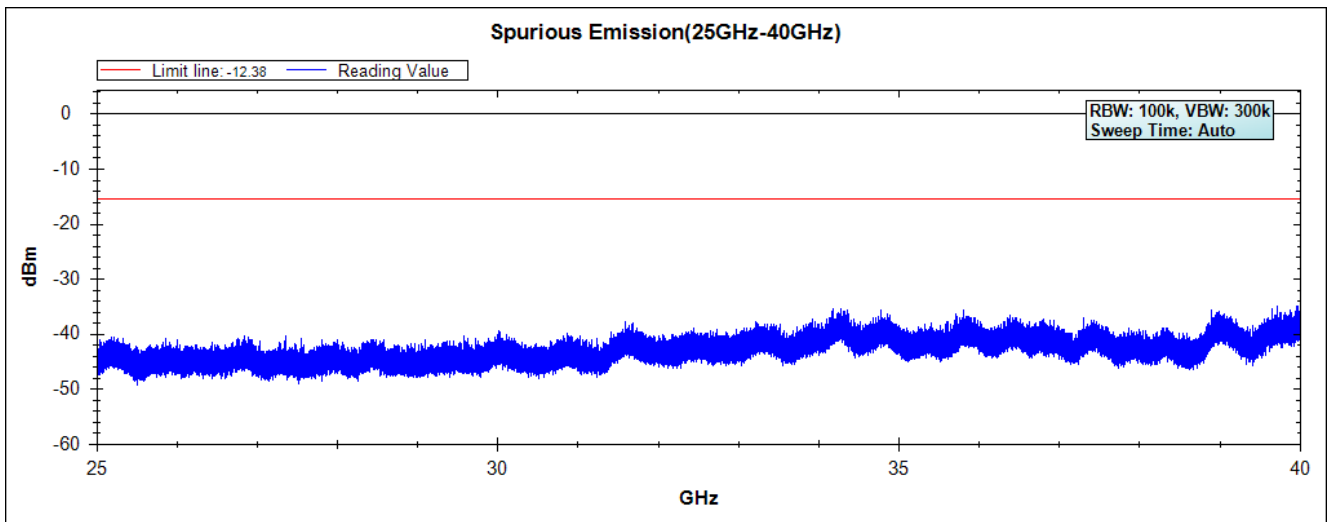
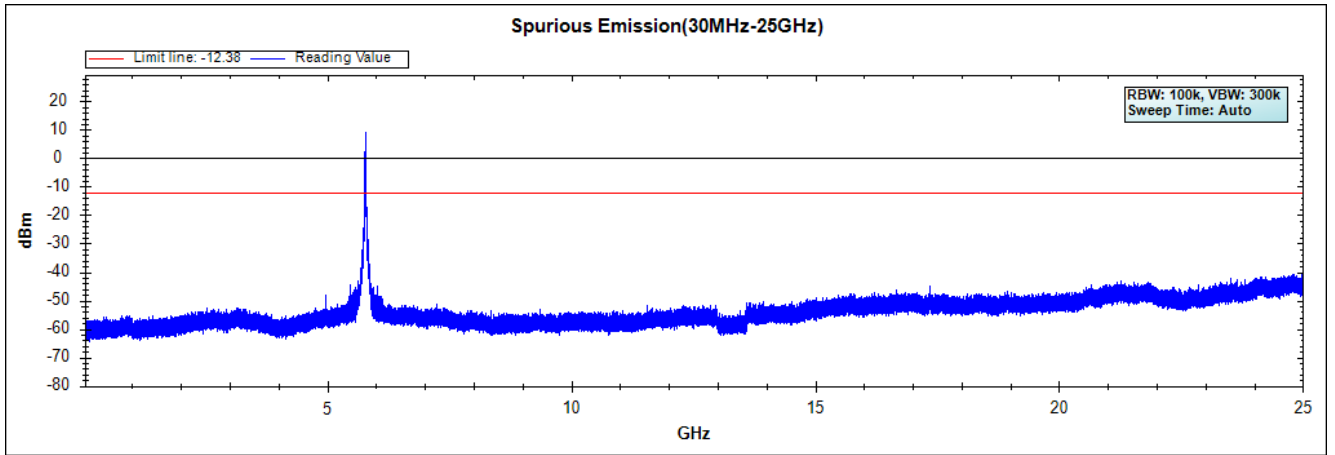

Note: The above test pattern is synthesized by multiple of the frequency range

Channel 165 (5825MHz) 30MHz -40GHz

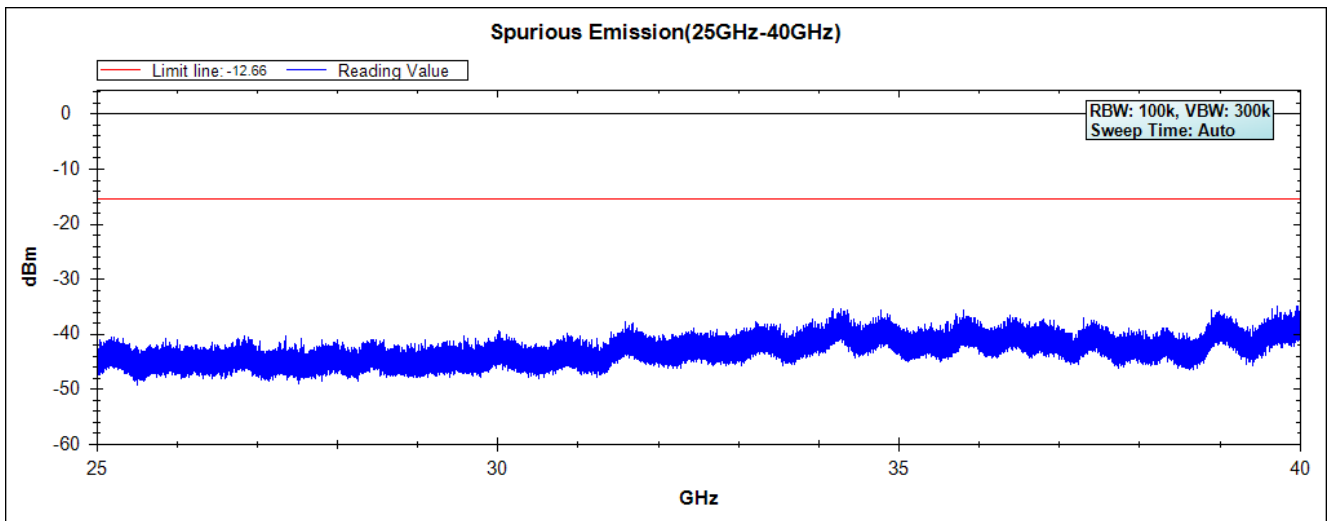
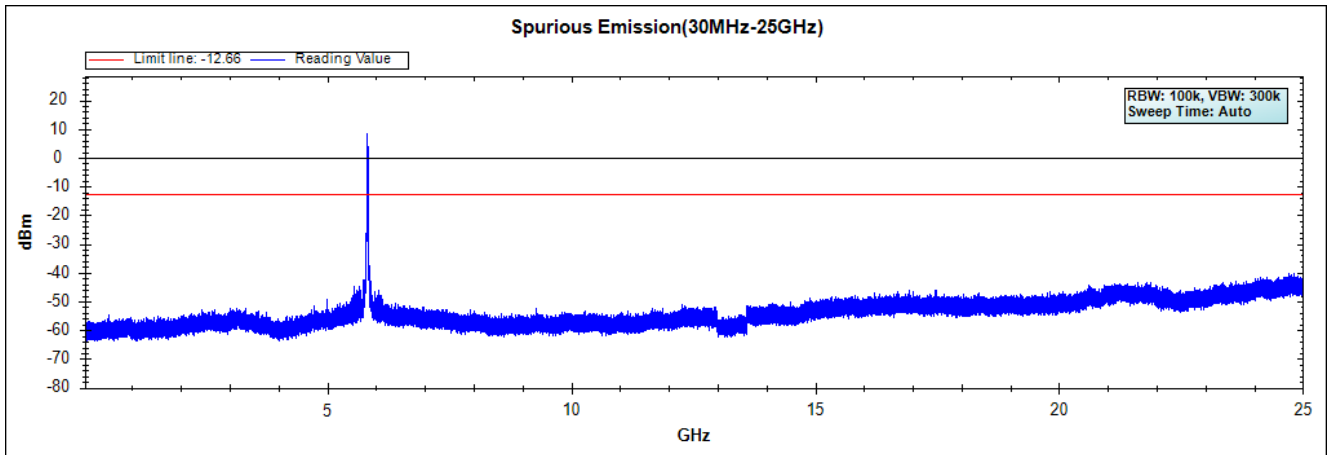

Note: The above test pattern is synthesized by multiple of the frequency range

Product : Intel® Dual Band Wireless-AC 8260  
Test Item : RF Antenna Conducted Spurious  
Test Site : No.3 OATS  
Test Mode : Mode 1 SISO A: Transmit - 802.11n-40BW\_15Mbps(5G Band)

**Channel 151 (5755MHz) 30MHz -40GHz**

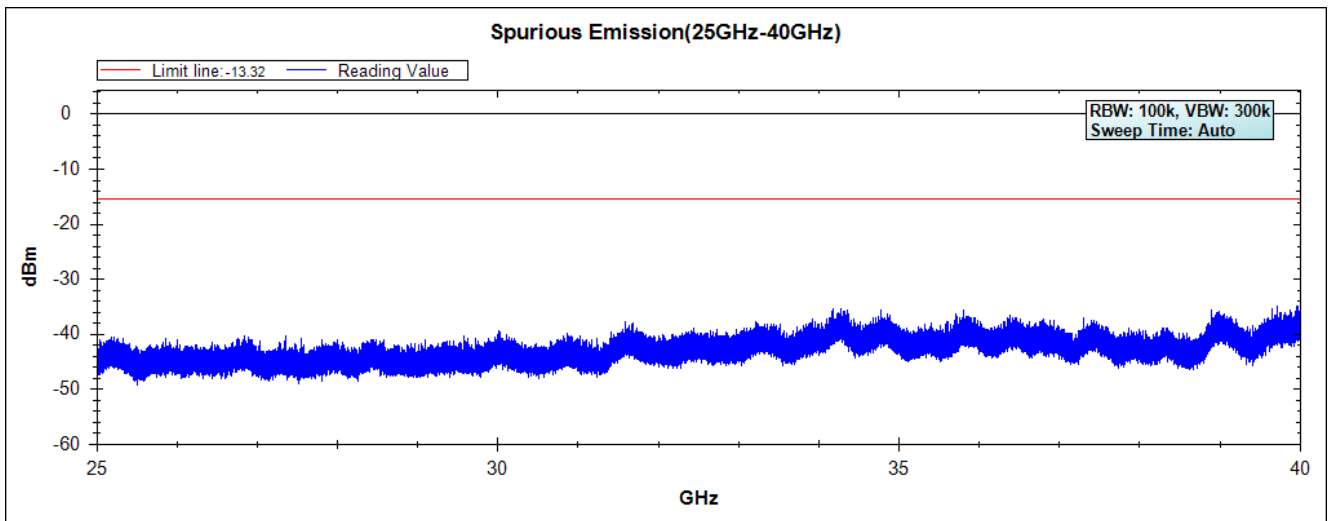
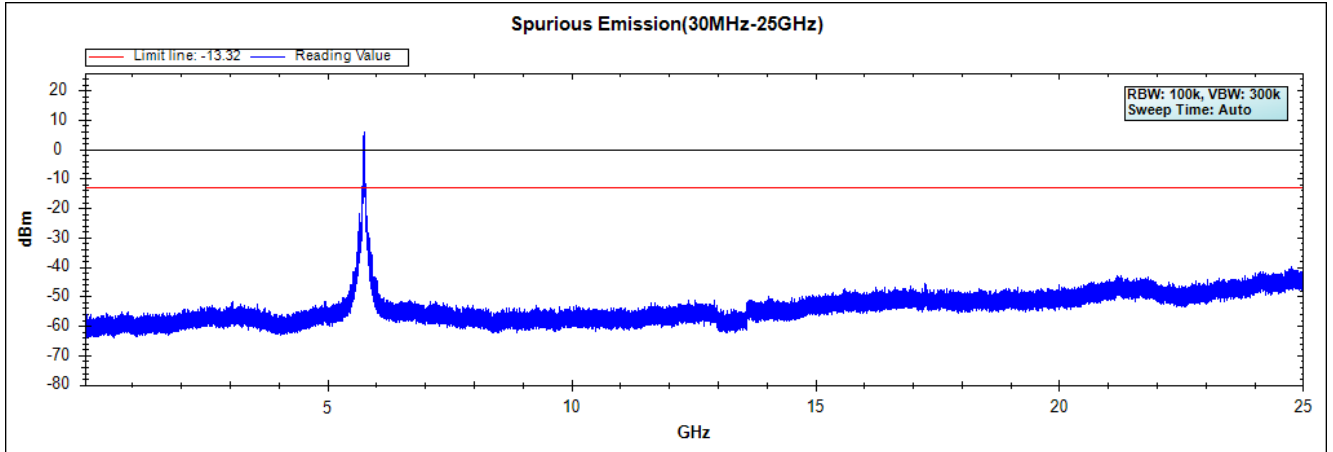

Note: The above test pattern is synthesized by multiple of the frequency range

Channel 159 (5795MHz) 30MHz -40GHz

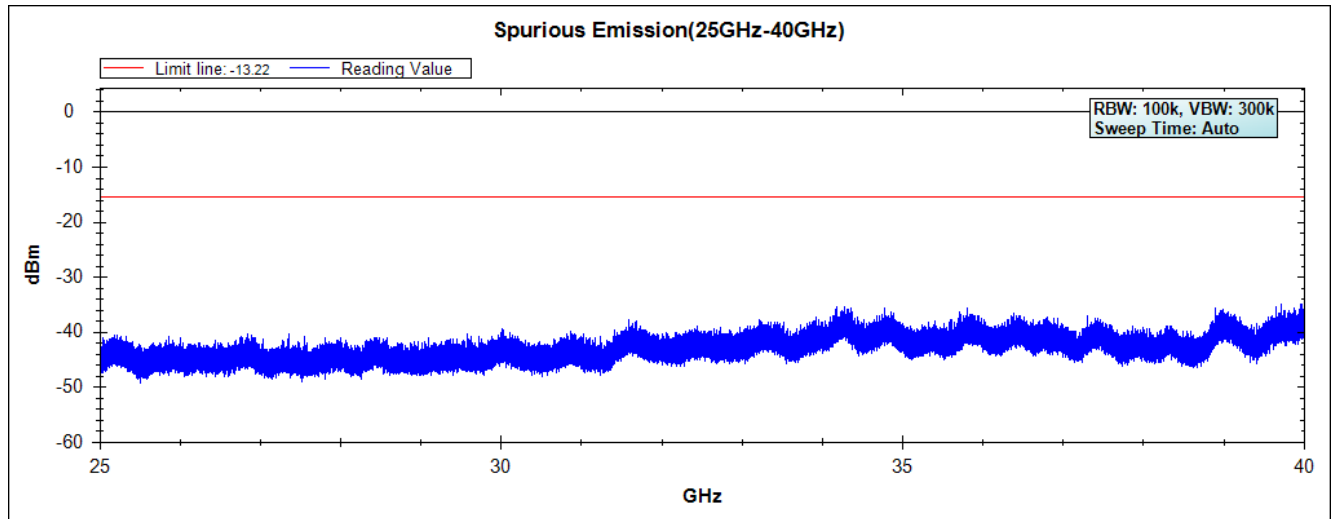
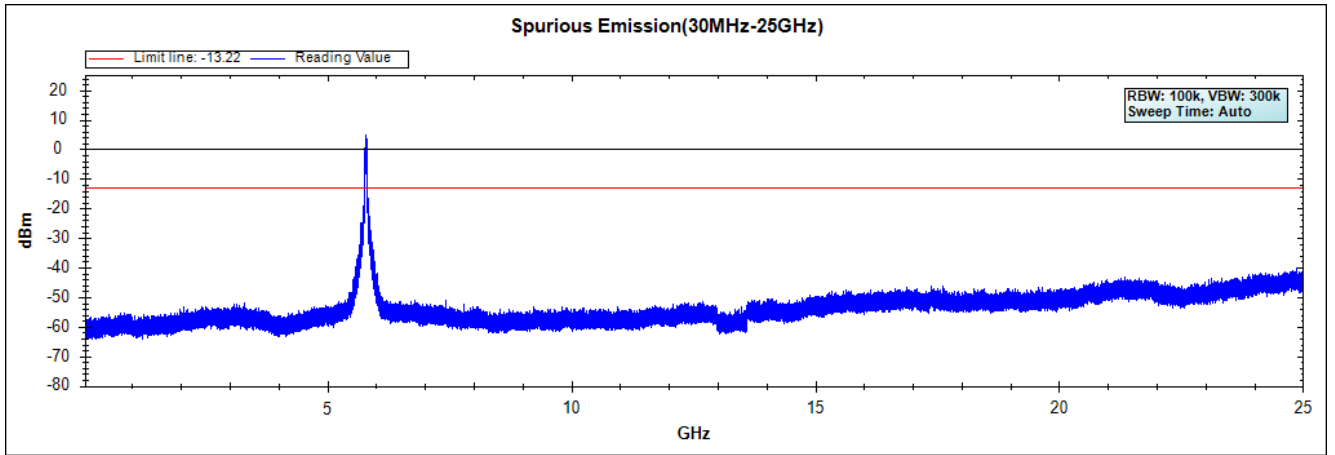

Note: The above test pattern is synthesized by multiple of the frequency range

Product : Intel® Dual Band Wireless-AC 8260  
Test Item : RF Antenna Conducted Spurious  
Test Site : No.3 OATS  
Test Mode : Mode 1 SISO A: Transmit - 802.11ac-80BW\_32.5Mbps(5G Band)

**Channel 155 (5775MHz) 30MHz -40GHz**

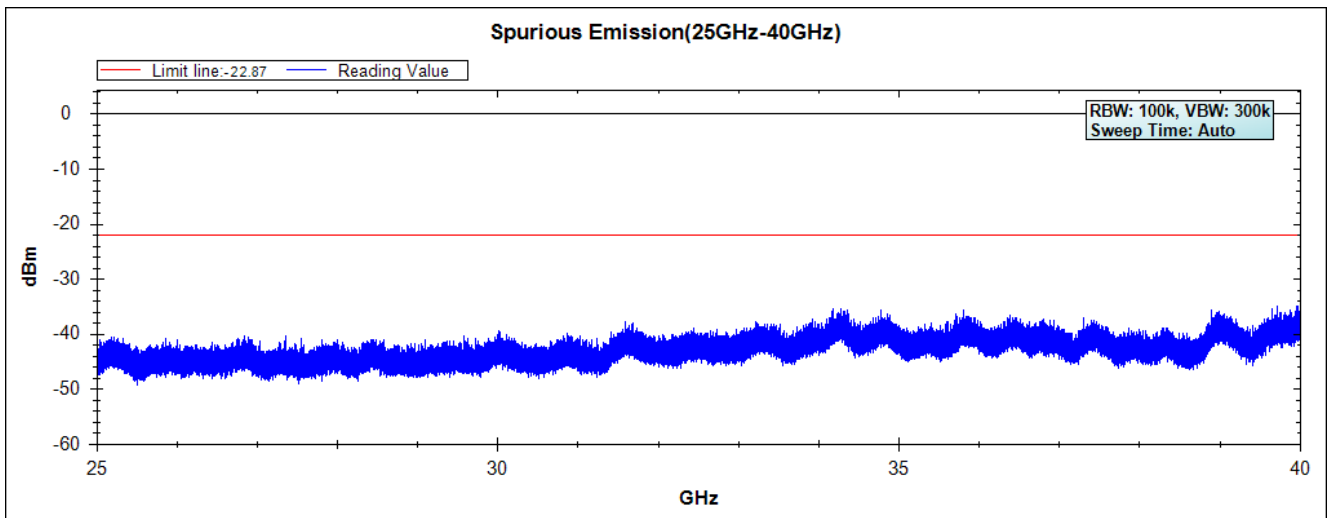
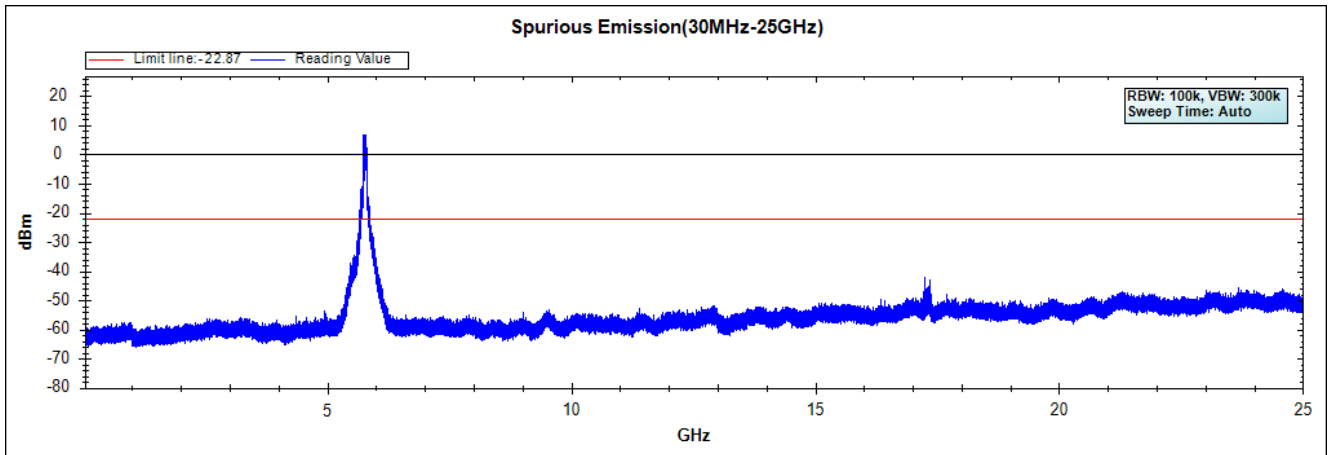

Note: The above test pattern is synthesized by multiple of the frequency range

Product : Intel® Dual Band Wireless-AC 8260  
 Test Item : RF antenna conducted test  
 Test Site : No.3 OATS  
 Test Mode : Mode 2 SISO B: Transmit (802.11b 1Mbps)

**Channel 01 (2412MHz) 30MHz-25GHz**

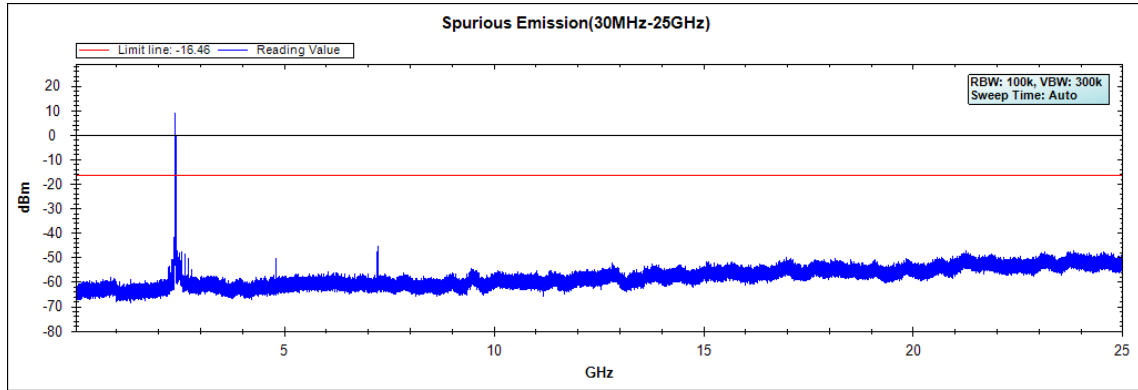

**Channel 06 (2437MHz) 30MHz -25GHz**

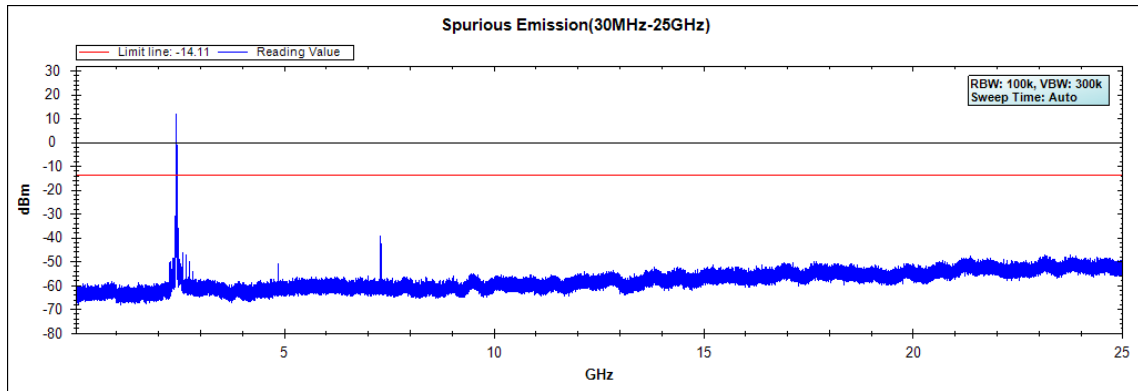

**Channel 11 (2462MHz) 30MHz -25GHz**

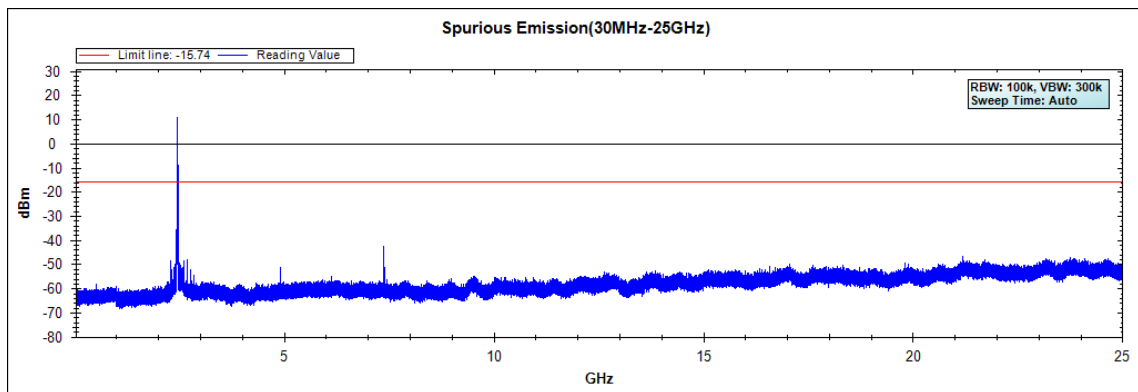

Channel 12 (2467MHz) 30MHz -25GHz

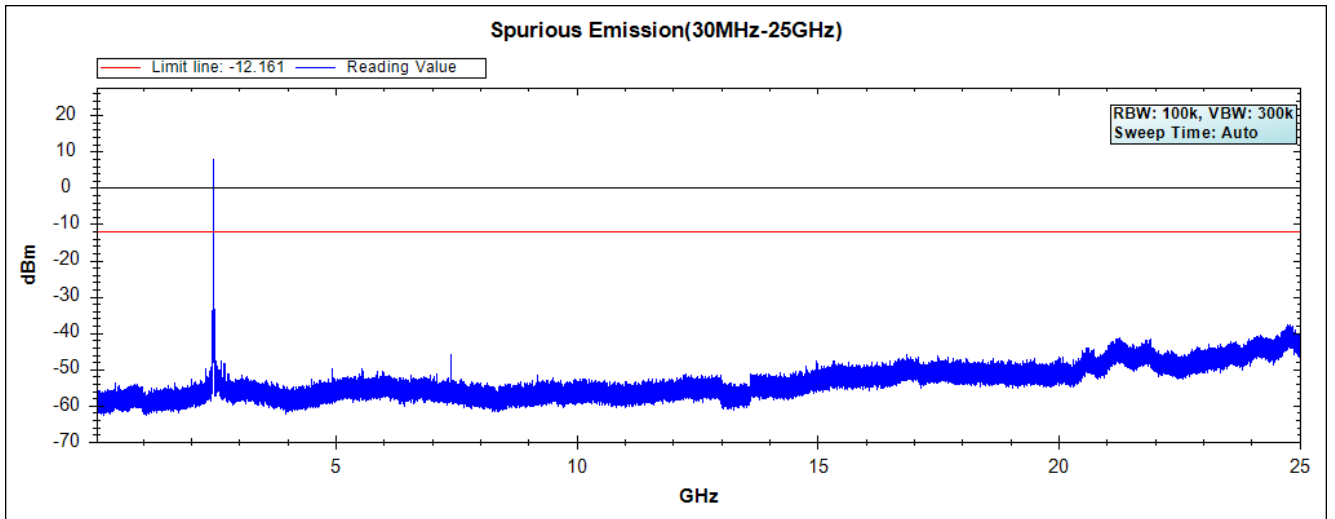

Note: The above test pattern is synthesized by multiple of the frequency range.



Product : Intel® Dual Band Wireless-AC 8260  
Test Item : RF Antenna Conducted Spurious  
Test Site : No.3 OATS  
Test Mode : Mode 2 SISO B: Transmit (802.11g 6Mbps)

**Channel 01 (2412MHz) 30MHz -25GHz**

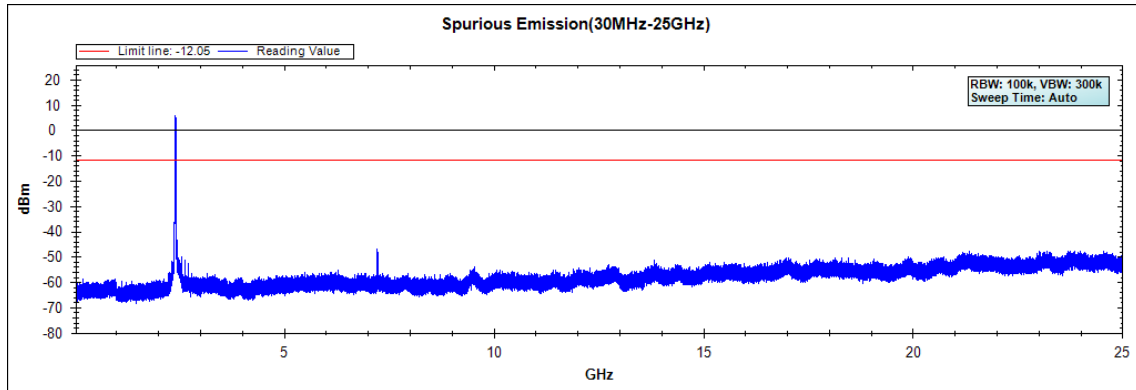

**Channel 06 (2437MHz) 30MHz -25GHz**

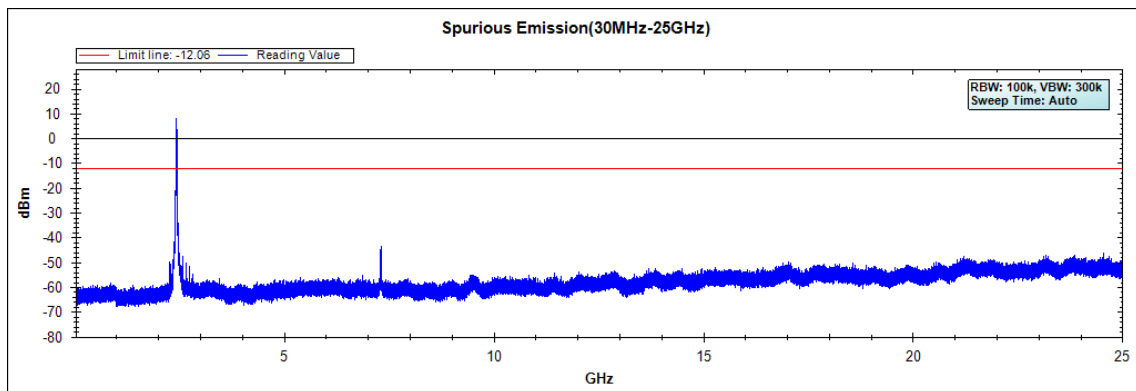

**Channel 11 (2462MHz) 30MHz -25GHz**

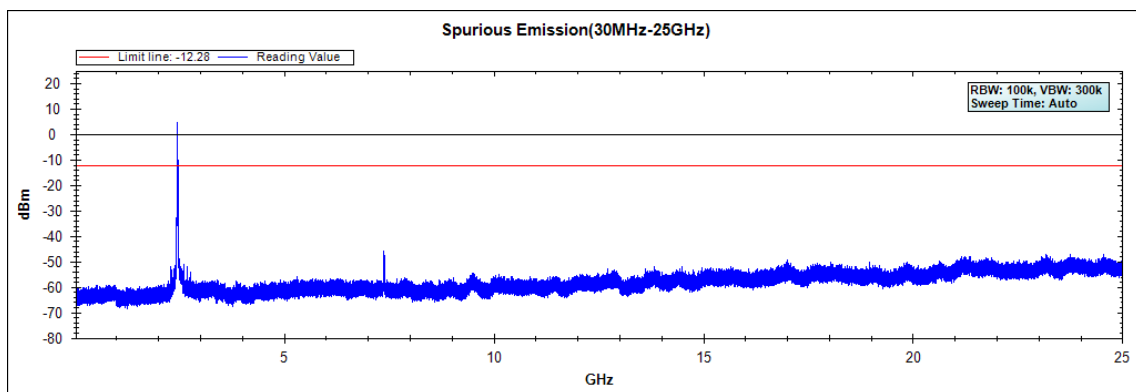

Channel 12 (2467MHz) 30MHz -25GHz

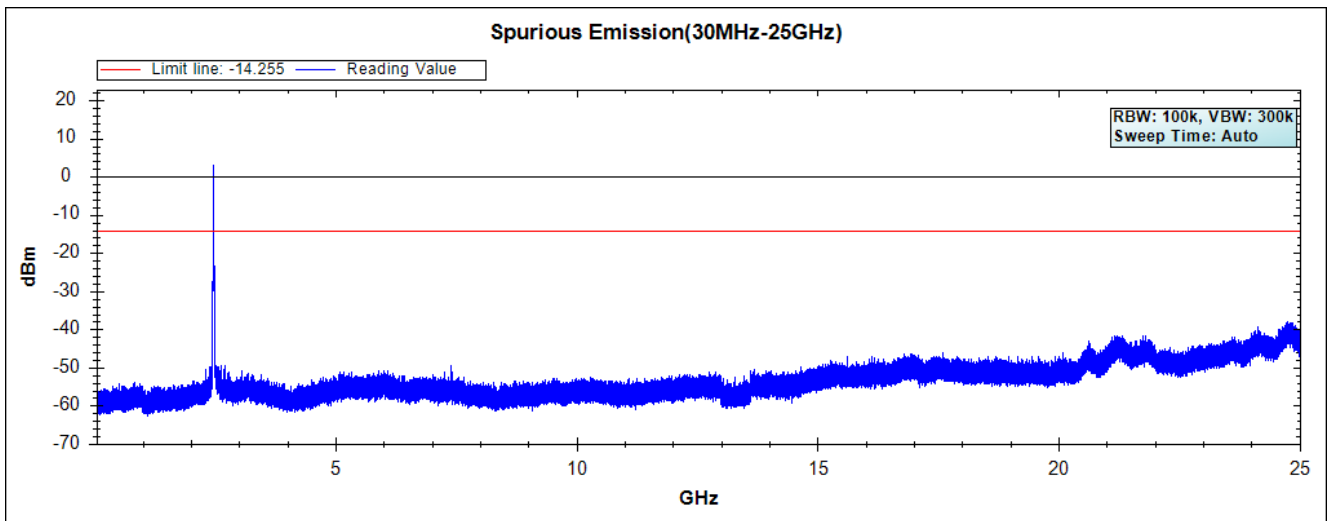

Note: The above test pattern is synthesized by multiple of the frequency range.

Product : Intel® Dual Band Wireless-AC 8260  
Test Item : RF Antenna Conducted Spurious  
Test Site : No.3 OATS  
Test Mode : Mode 2 SISO B: Transmit - 802.11a 6Mbps

**Channel 149 (5745MHz) 30MHz -40GHz**

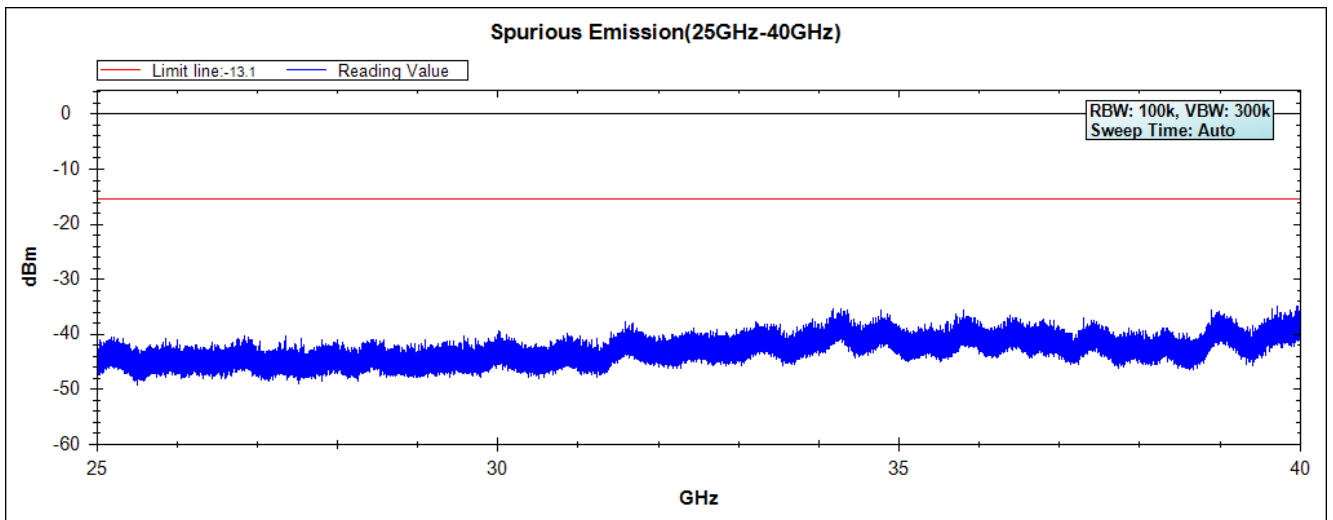
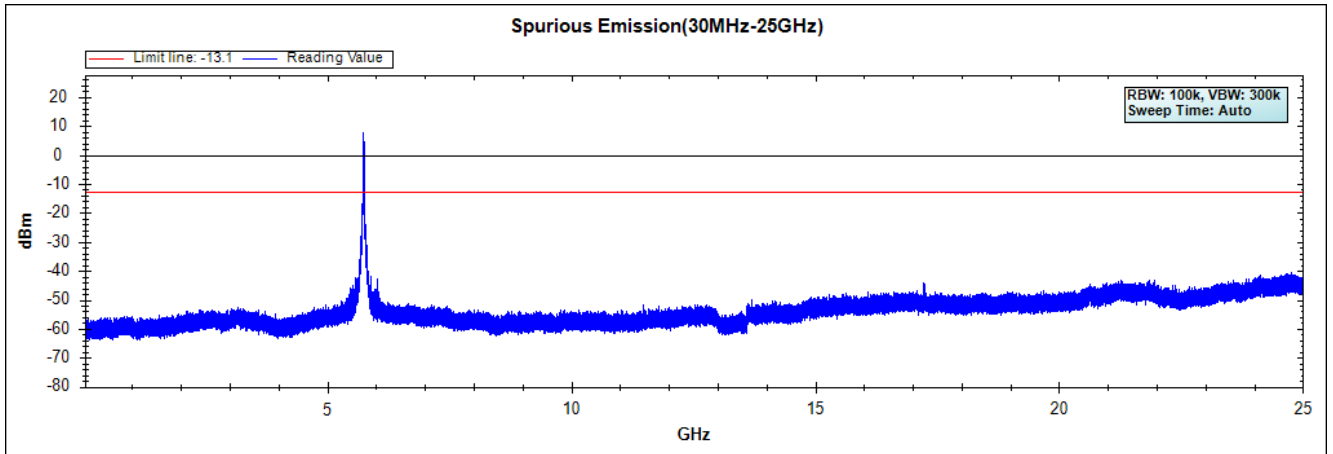

Note: The above test pattern is synthesized by multiple of the frequency range.

Channel 157 (5785MHz) 30MHz -40GHz

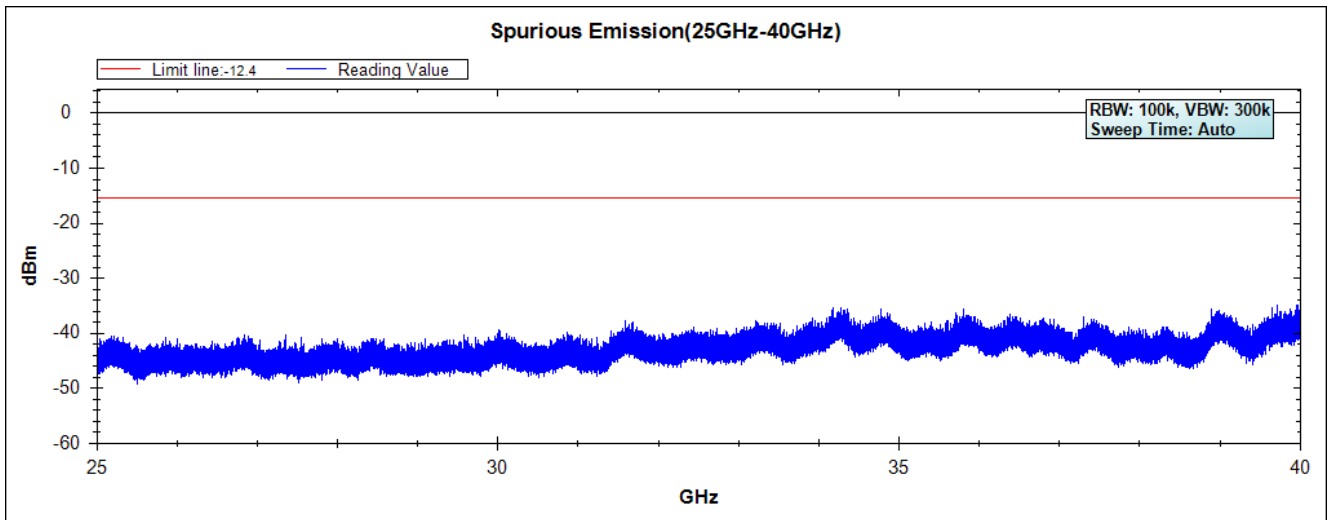
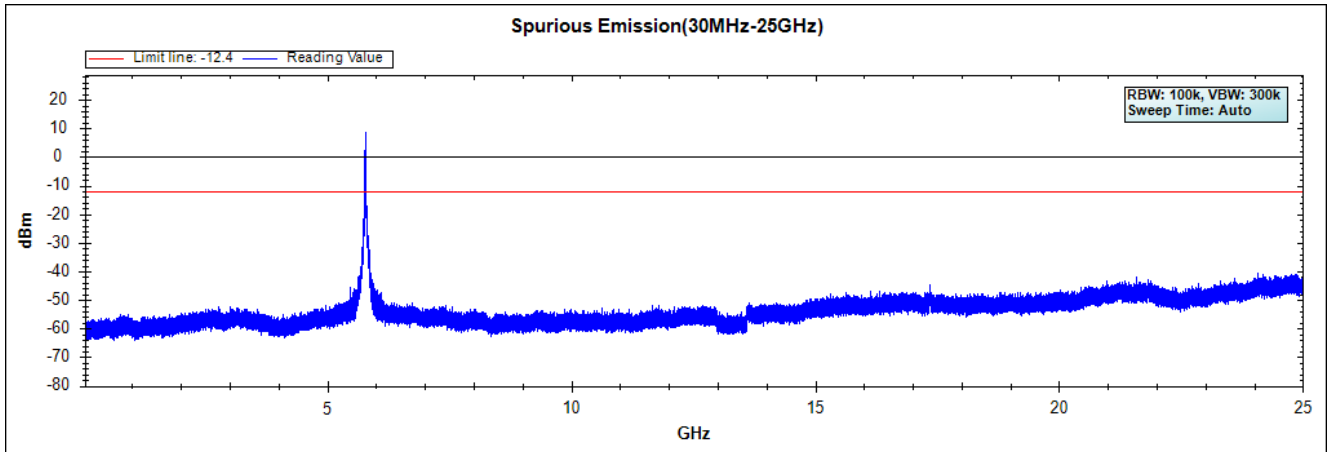

Note: The above test pattern is synthesized by multiple of the frequency range.

Channel 165 (5825MHz) 30MHz -40GHz

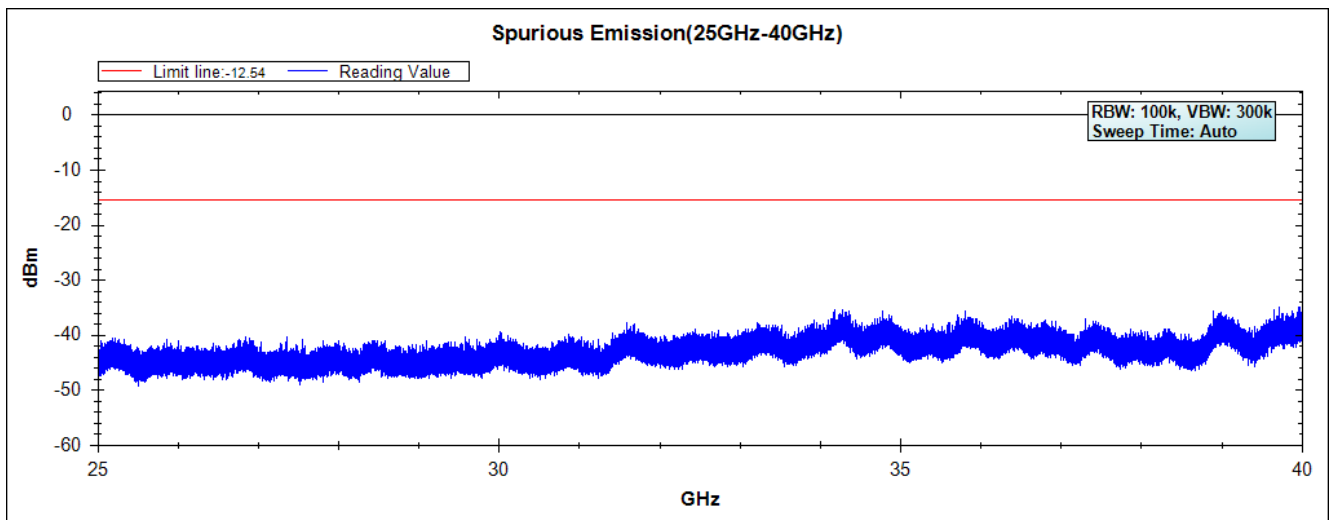
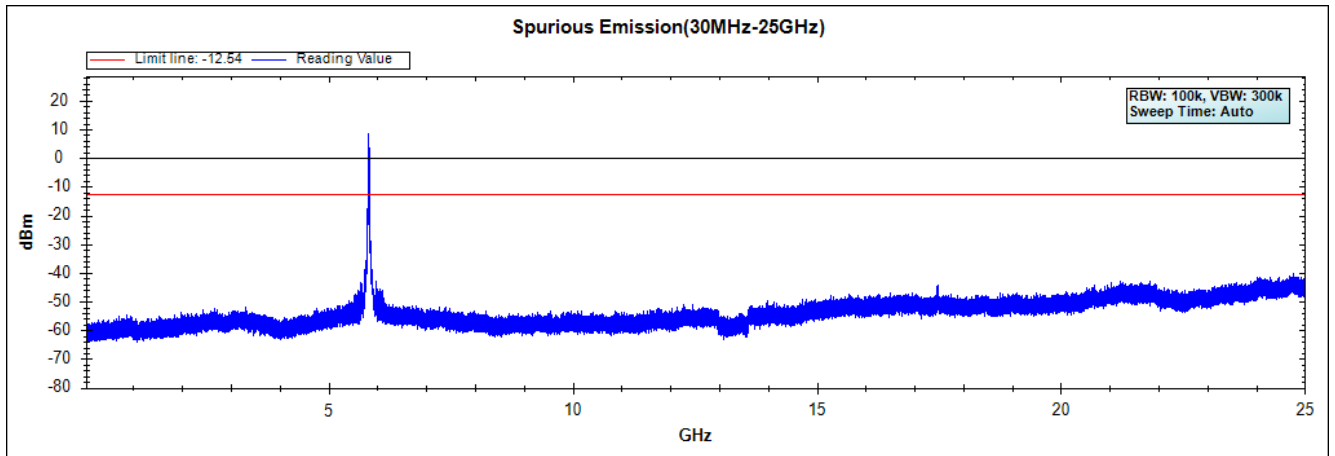

Note: The above test pattern is synthesized by multiple of the frequency range.

Product : Intel® Dual Band Wireless-AC 8260  
Test Item : RF Antenna Conducted Spurious  
Test Site : No.3 OATS  
Test Mode : Mode 2 SISO B: Transmit - 802.11n-20BW\_7.2Mbps(2.4G Band)

**Channel 01 (2412MHz) 30MHz -25GHz**

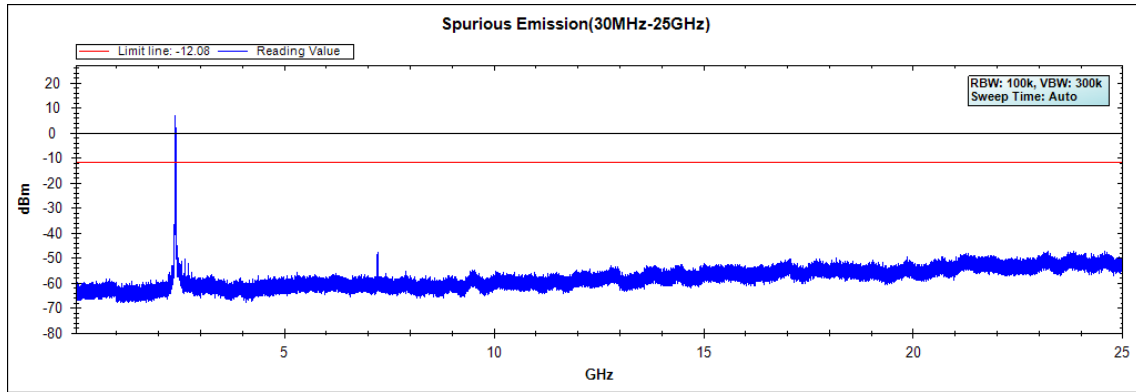

**Channel 06 (2437MHz) 30MHz -25GHz**

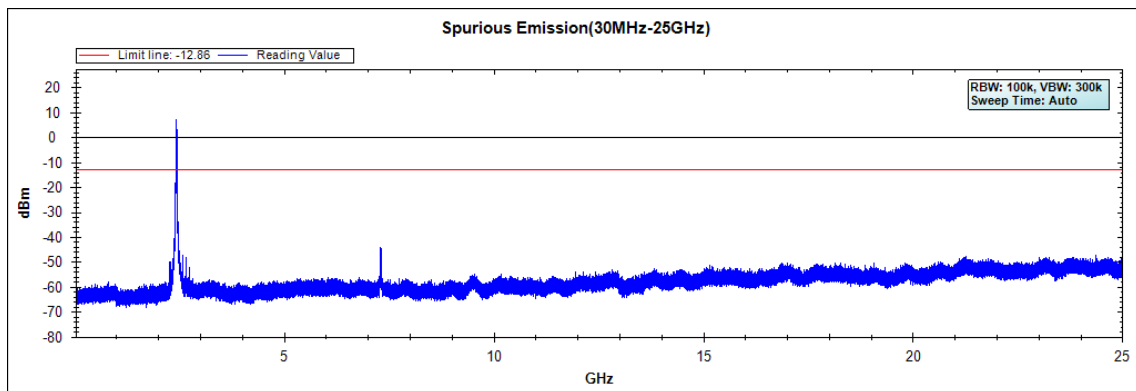

**Channel 11 (2462MHz) 30MHz -25GHz**

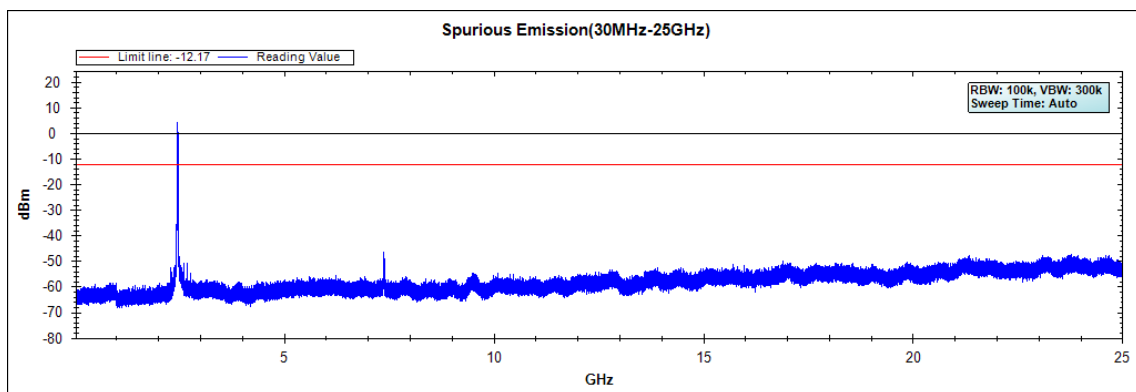

Channel 12 (2467MHz) 30MHz -25GHz

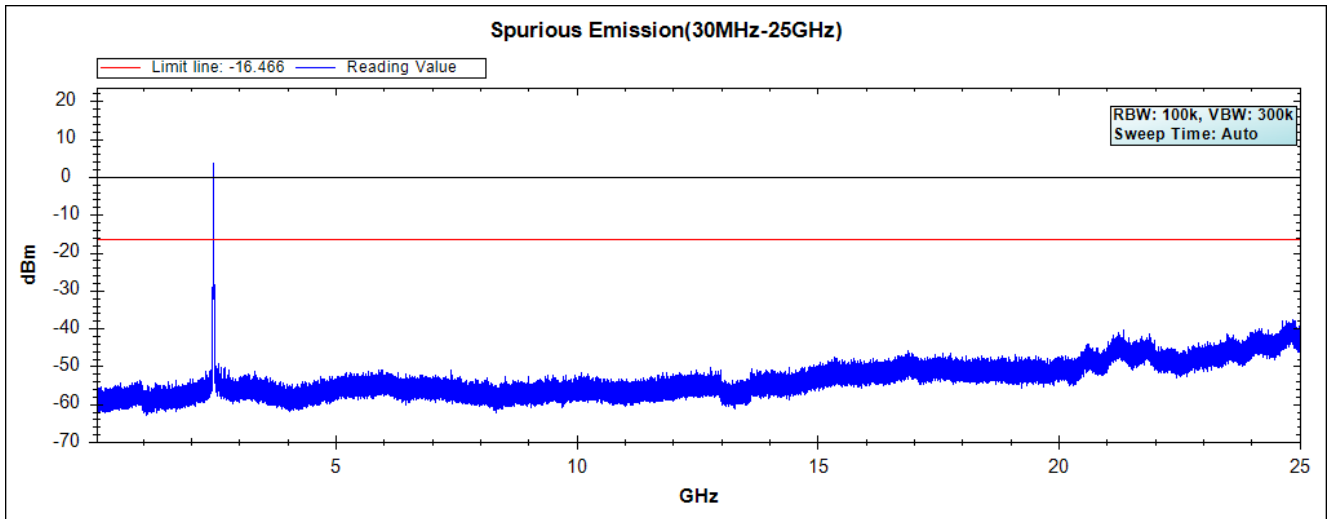

Note: The above test pattern is synthesized by multiple of the frequency range.

Product : Intel® Dual Band Wireless-AC 8260  
 Test Item : RF Antenna Conducted Spurious  
 Test Site : No.3 OATS  
 Test Mode : Mode 2 SISO B: Transmit - 802.11n-40BW\_15Mbps(2.4G Band)

**Channel 03 (2422MHz) 30MHz -25GHz**

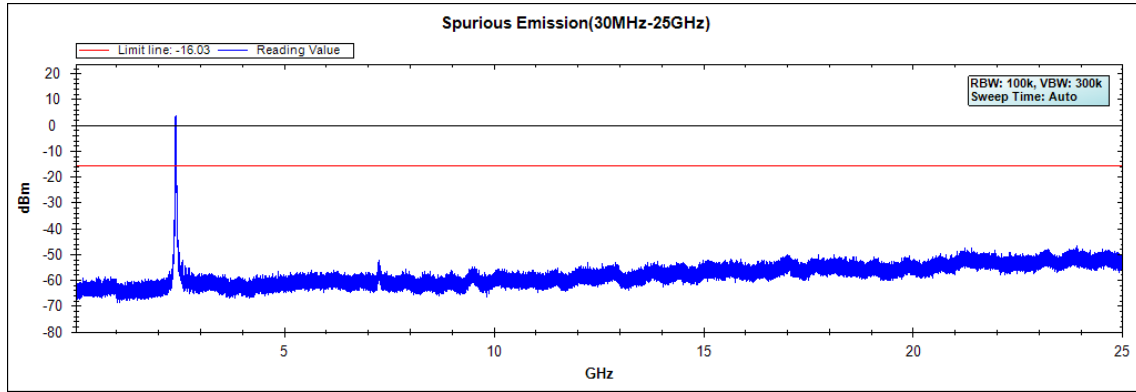

**Channel 06 (2437MHz) 30MHz -25GHz**

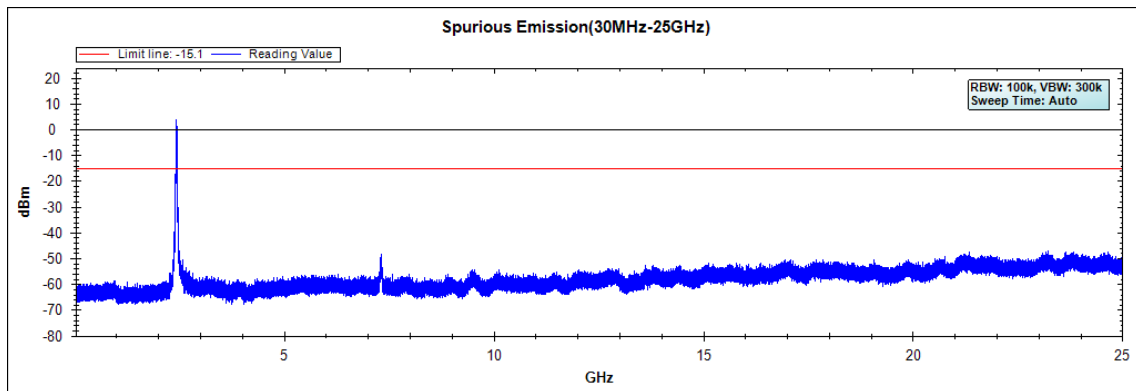

**Channel 09 (2452MHz) 30MHz -25GHz**

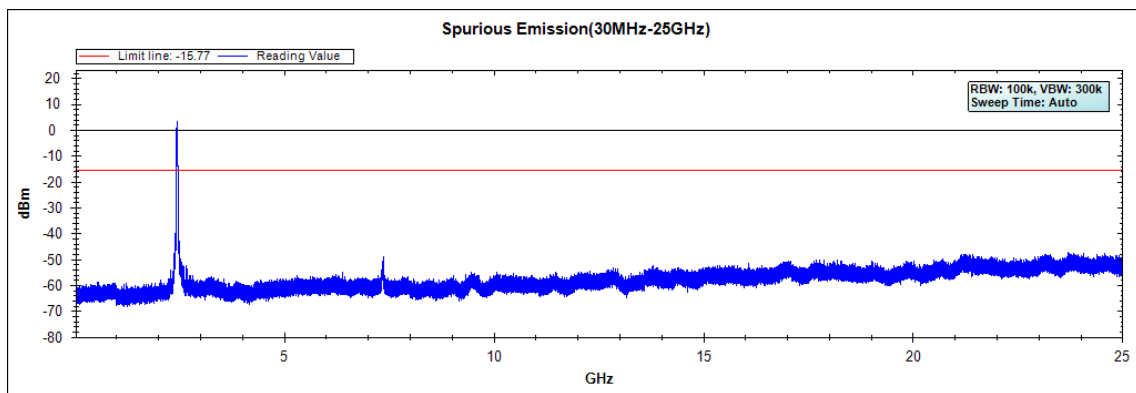



Channel 10 (2457MHz) 30MHz -25GHz

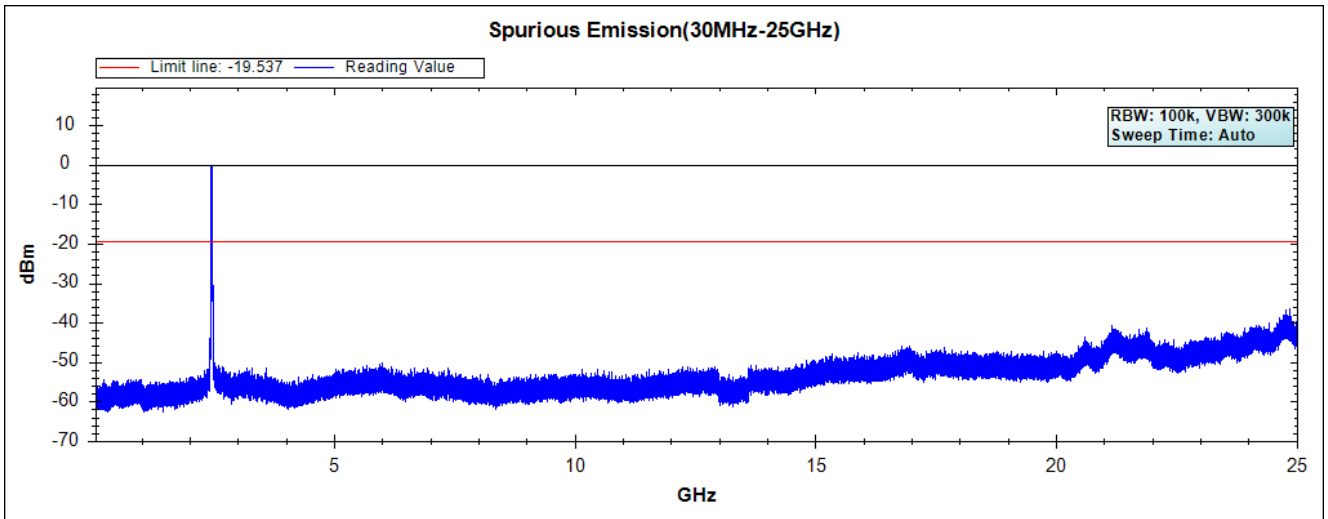

Note: The above test pattern is synthesized by multiple of the frequency range.

Product : Intel® Dual Band Wireless-AC 8260  
 Test Item : RF Antenna Conducted Spurious  
 Test Site : No.3 OATS  
 Test Mode : Mode 2 SISO B: Transmit - 802.11n-20BW\_7.2Mbps(5G Band)

**Channel 49 (5745MHz) 30MHz -40GHz**

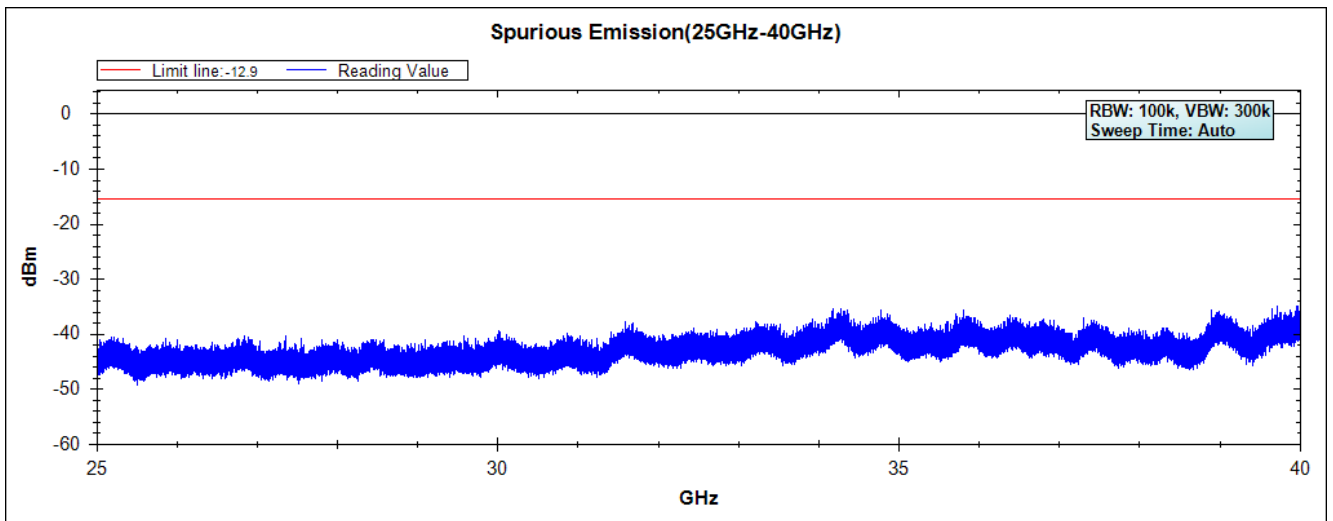
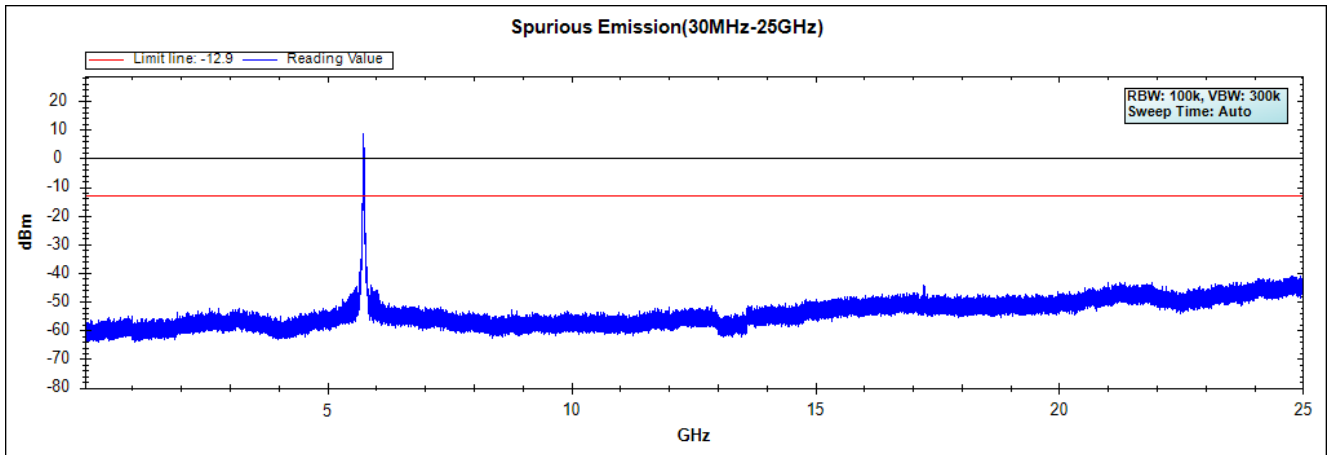

Note: The above test pattern is synthesized by multiple of the frequency range

Channel 157 (5785MHz) 30MHz -40GHz

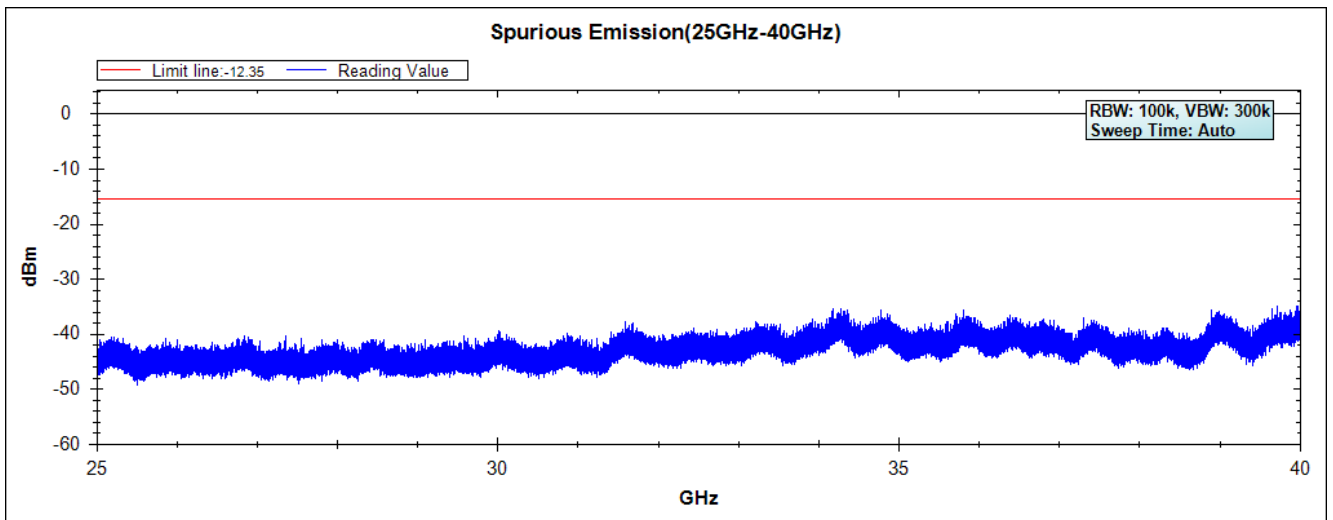
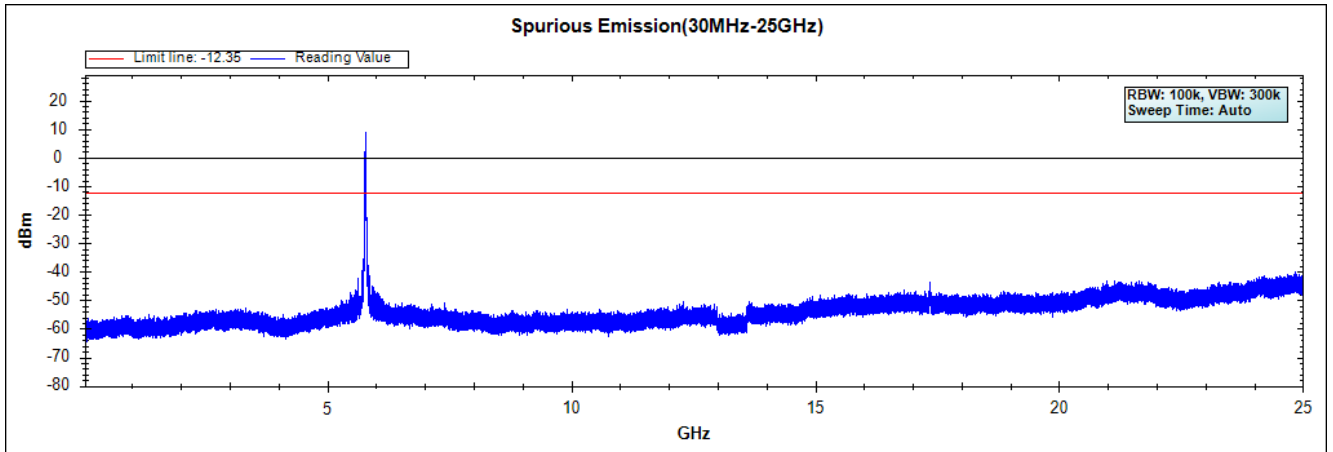

Note: The above test pattern is synthesized by multiple of the frequency range

Channel 165 (5825MHz) 30MHz -40GHz

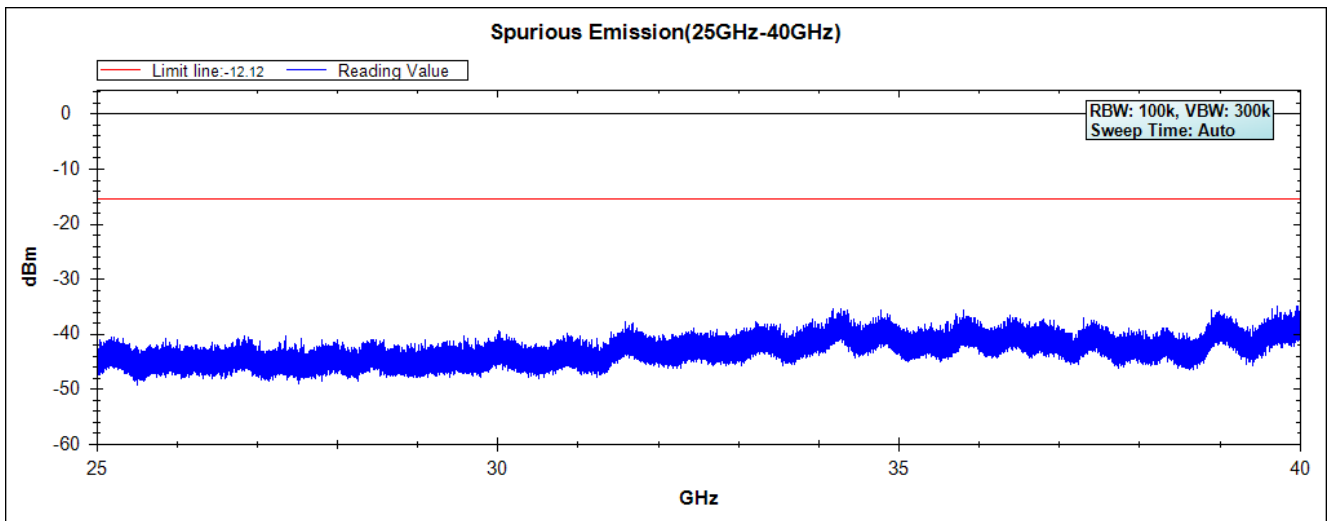
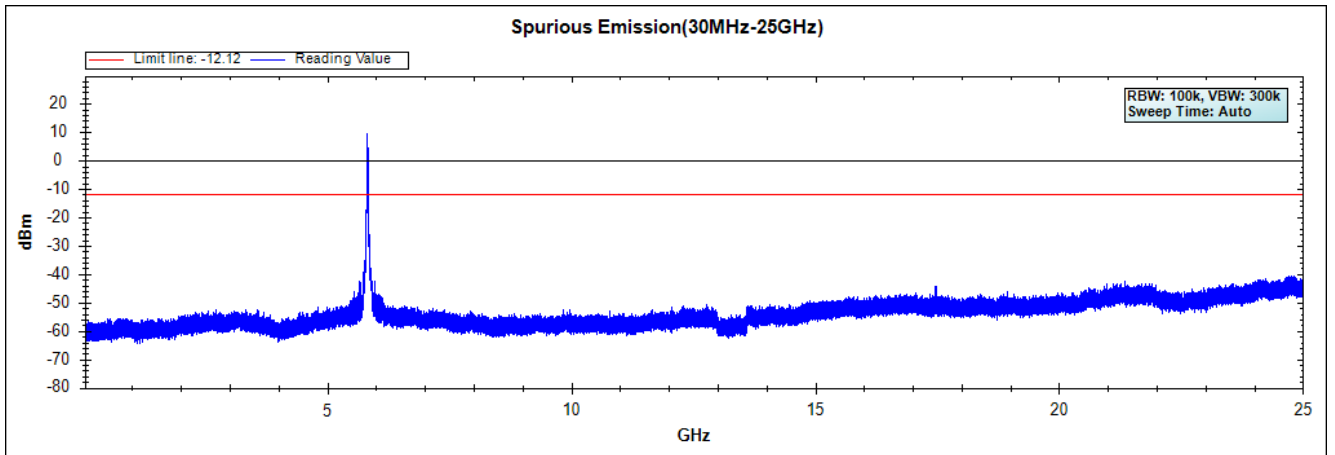

Note: The above test pattern is synthesized by multiple of the frequency range

Product : Intel® Dual Band Wireless-AC 8260  
 Test Item : RF Antenna Conducted Spurious  
 Test Site : No.3 OATS  
 Test Mode : Mode 2 SISO B: Transmit - 802.11n-40BW\_15Mbps(5G Band)

**Channel 151 (5755MHz) 30MHz -40GHz**

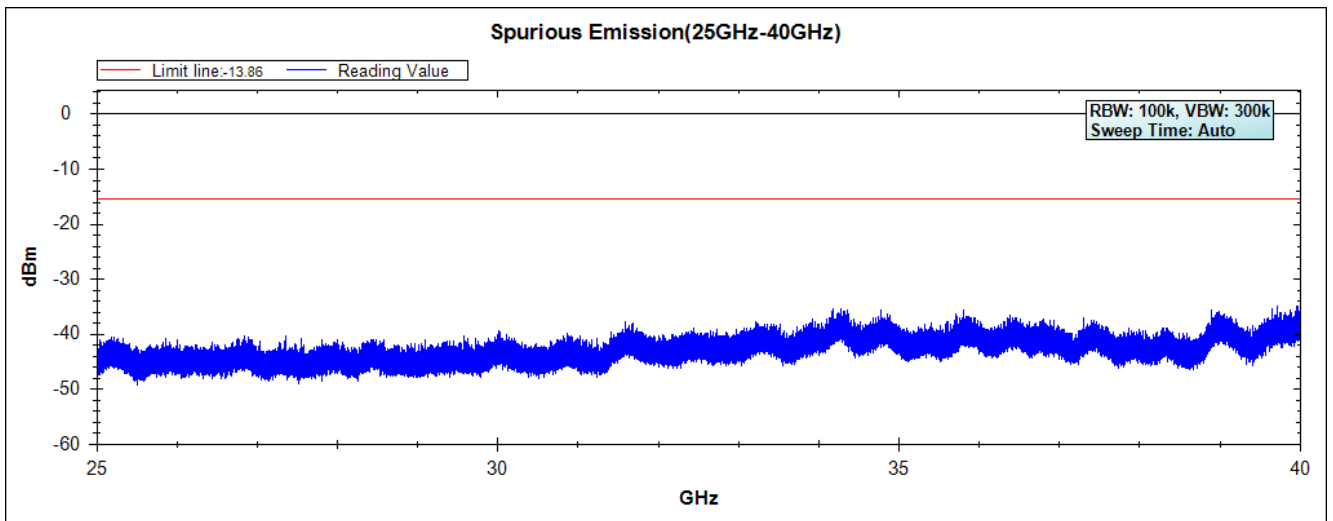
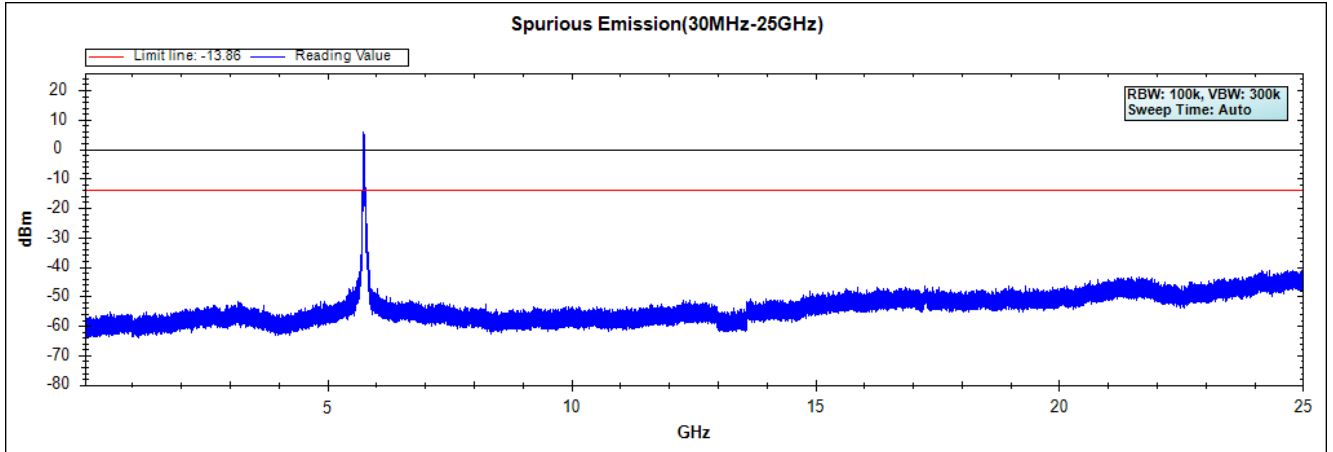

Note: The above test pattern is synthesized by multiple of the frequency range

Channel 159 (5795MHz) 30MHz -40GHz

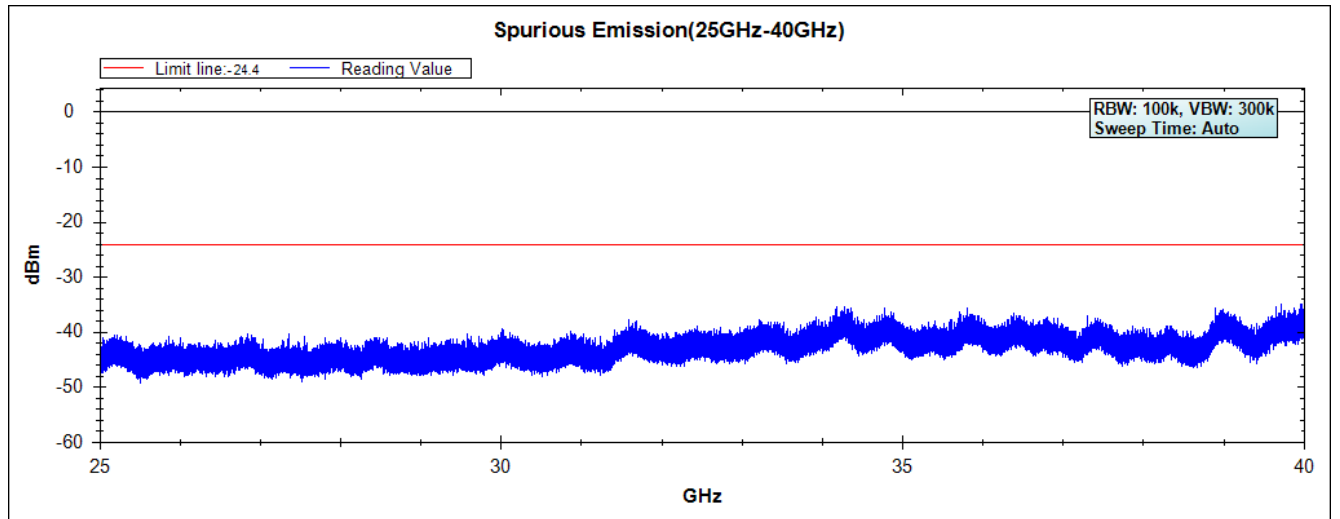
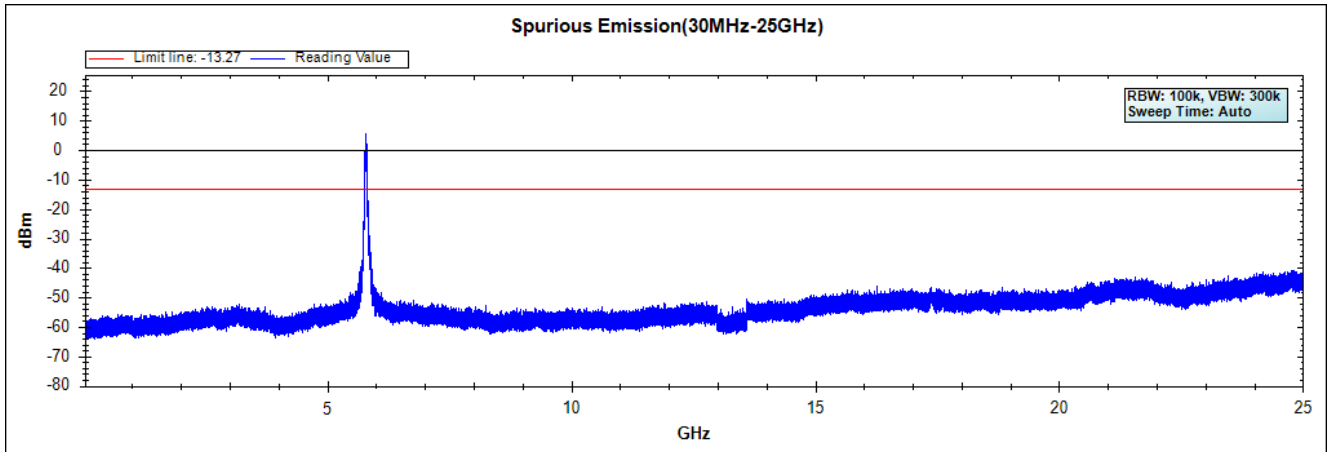

Note: The above test pattern is synthesized by multiple of the frequency range

Product : Intel® Dual Band Wireless-AC 8260  
 Test Item : RF Antenna Conducted Spurious  
 Test Site : No.3 OATS  
 Test Mode : Mode 2 SISO B: Transmit - 802.11ac-80BW\_32.5Mbps(5G Band)

**Channel 155 (5775MHz) 30MHz -40GHz**

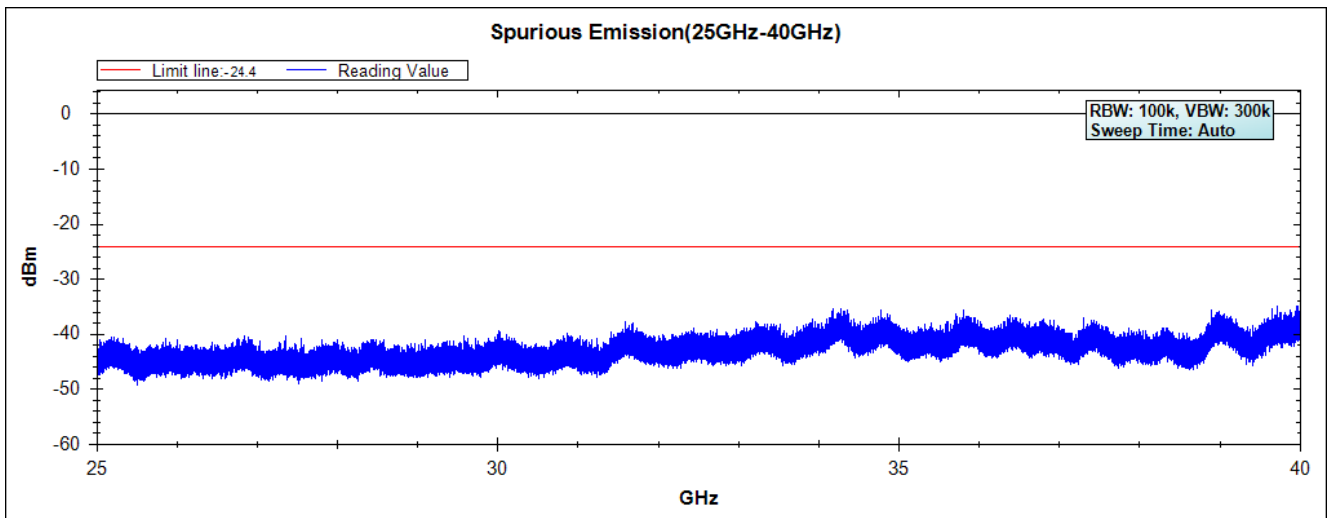
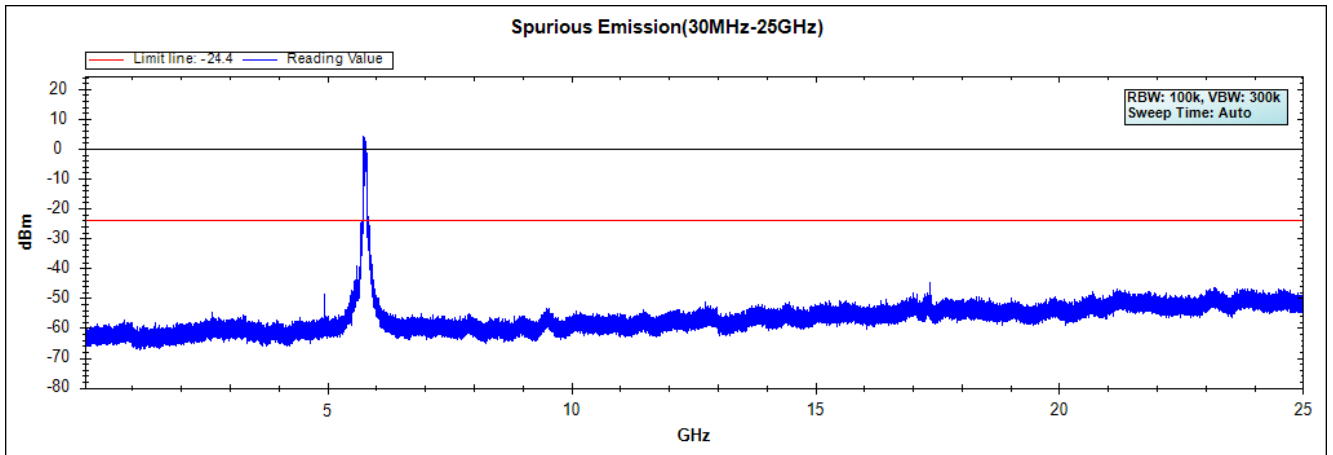

Note: The above test pattern is synthesized by multiple of the frequency range

Product : Intel® Dual Band Wireless-AC 8260  
 Test Item : RF Antenna Conducted Spurious  
 Test Site : No.3 OATS  
 Test Mode : Mode 3 MIMO: Transmit - 802.11n-20BW\_14.4Mbps(2.4G Band)

**Chaia A**

**Channel 01 (2412MHz) 30MHz -25GHz**

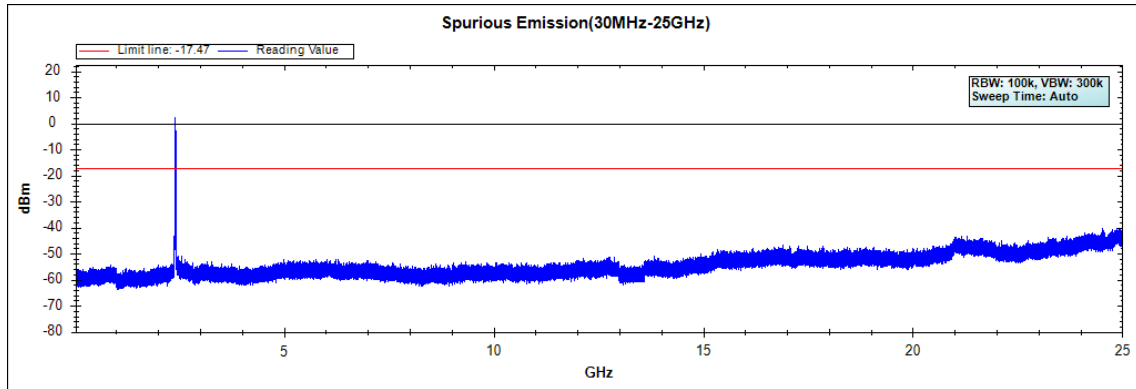

**Channel 06 (2437MHz) 30MHz -25GHz**

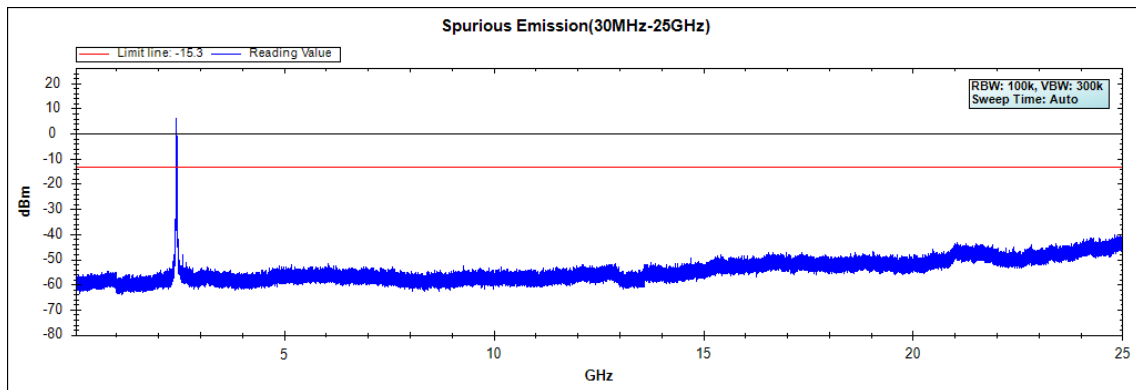

**Channel 11 (2462MHz) 30MHz -25GHz**

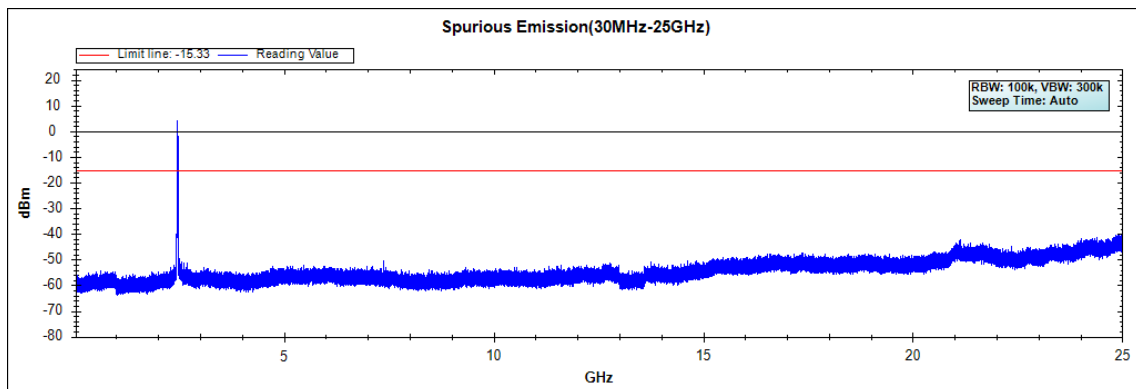



Channel 12 (2467MHz) 30MHz -25GHz

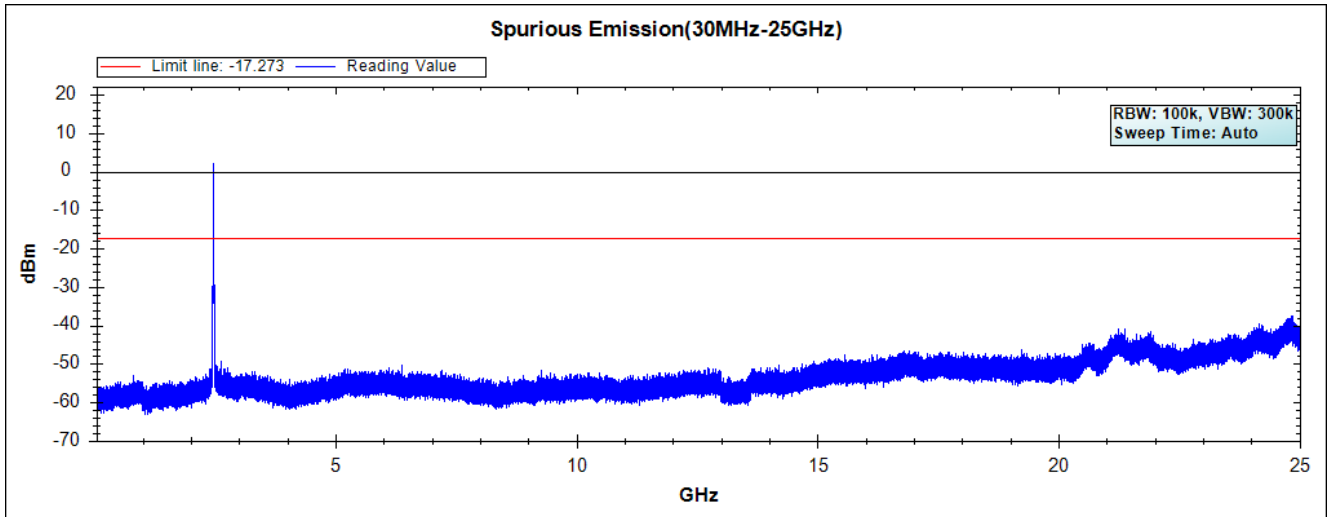

Note: The above test pattern is synthesized by multiple of the frequency range.

Product : Intel® Dual Band Wireless-AC 8260  
Test Item : RF Antenna Conducted Spurious  
Test Site : No.3 OATS  
Test Mode : Mode 3 MIMO: Transmit - 802.11n-40BW\_30Mbps(2.4G Band)

**Chaia A**

**Channel 03 (2422MHz) 30MHz -25GHz**

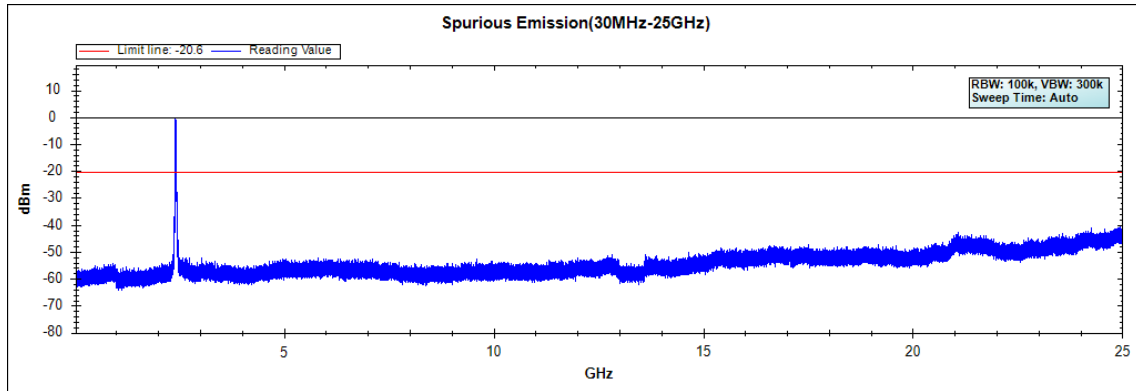

**Channel 06 (2437MHz) 30MHz -25GHz**

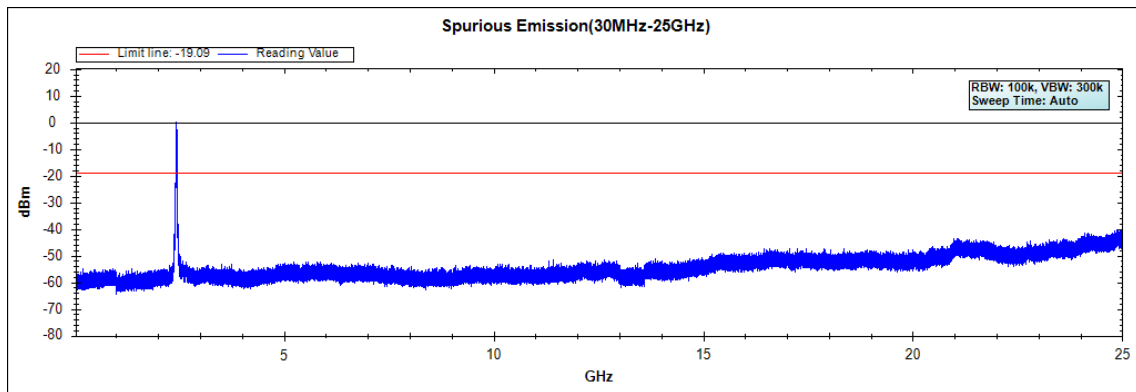

**Channel 09 (2452MHz) 30MHz -25GHz**

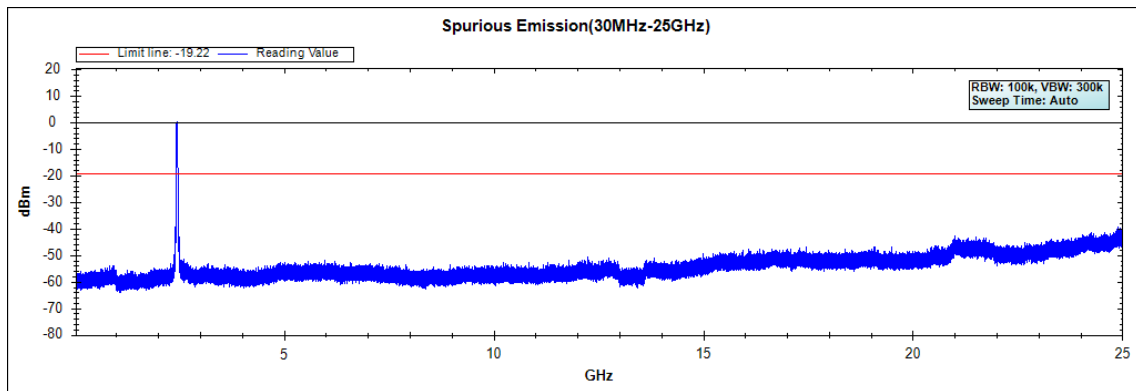

Channel 10 (2457MHz) 30MHz -25GHz

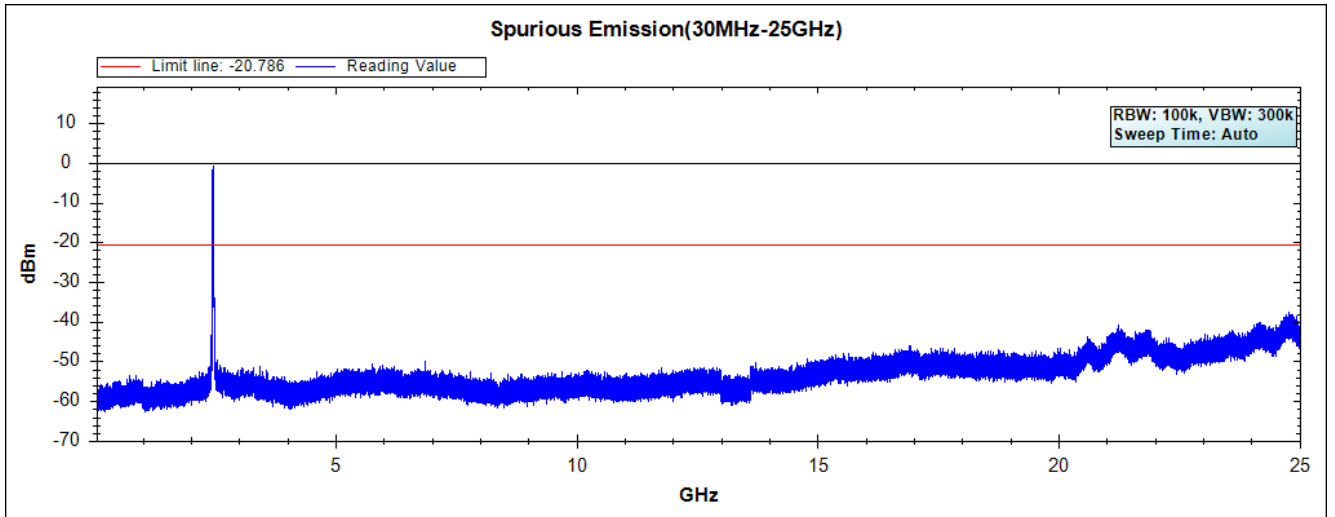

Note: The above test pattern is synthesized by multiple of the frequency range.

Product : Intel® Dual Band Wireless-AC 8260  
 Test Item : RF Antenna Conducted Spurious  
 Test Site : No.3 OATS  
 Test Mode : Mode 3 MIMO: Transmit - 802.11n-20BW\_14.4Mbps(5G Band)

**Chaia A**

**Channel 49 (5745MHz) 30MHz -40GHz**

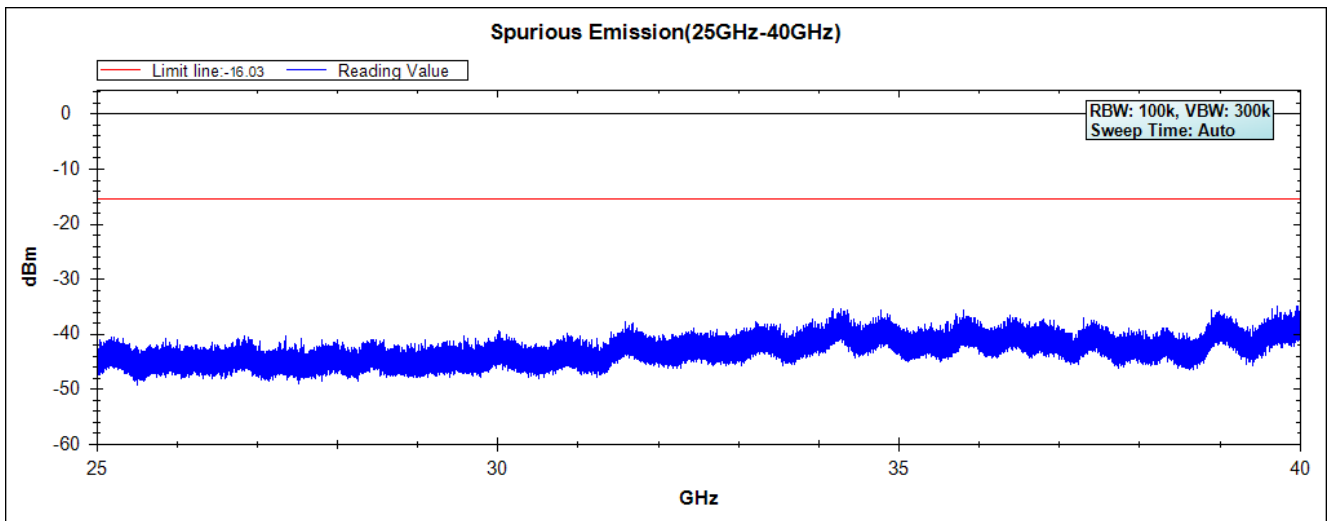
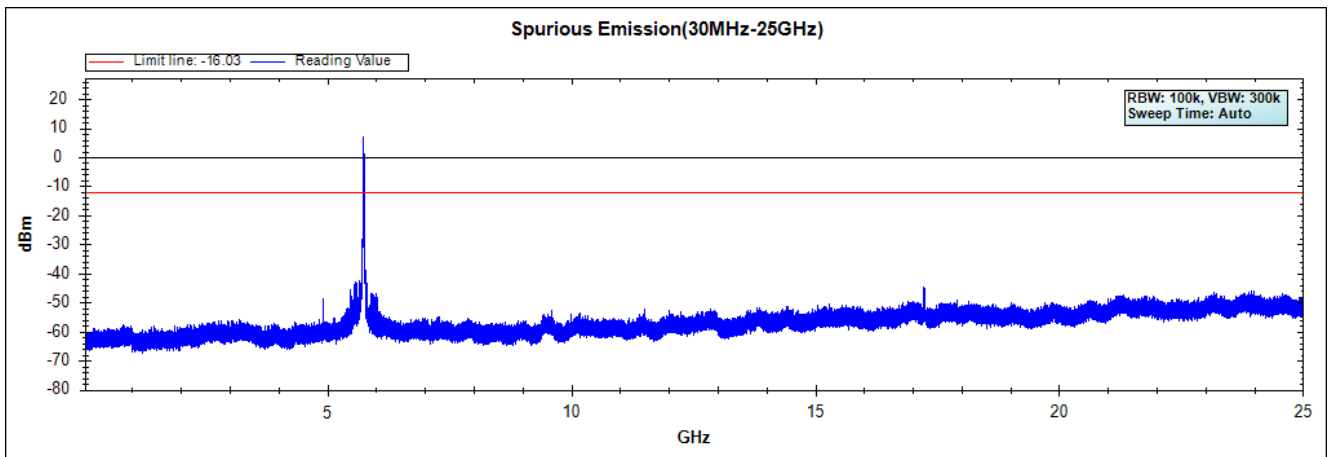

Note: The above test pattern is synthesized by multiple of the frequency range

Channel 157 (5785MHz) 30MHz -40GHz

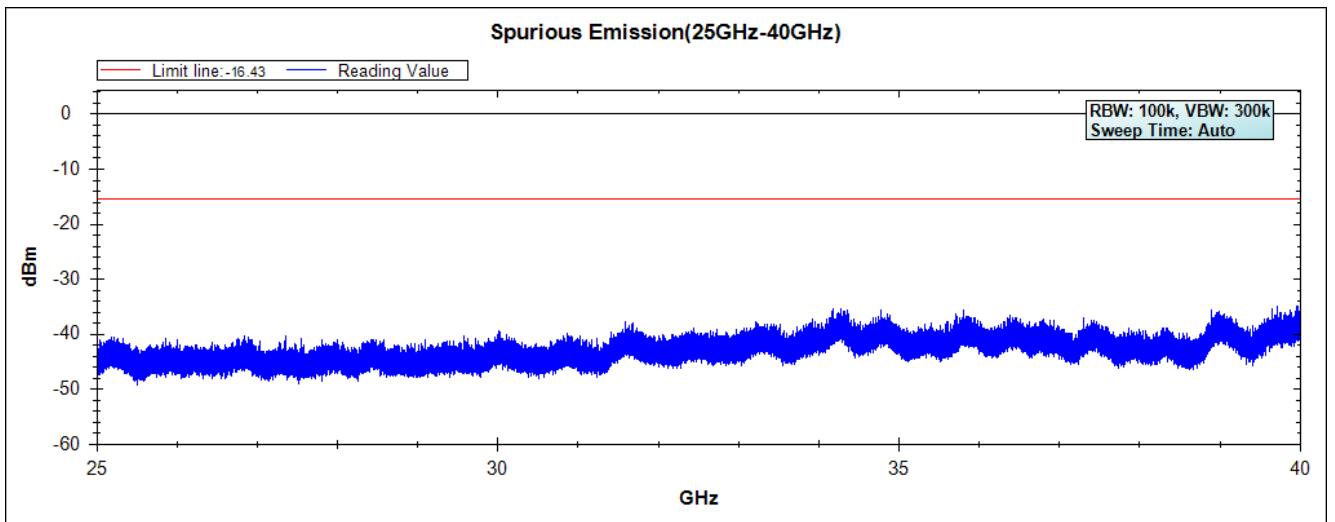
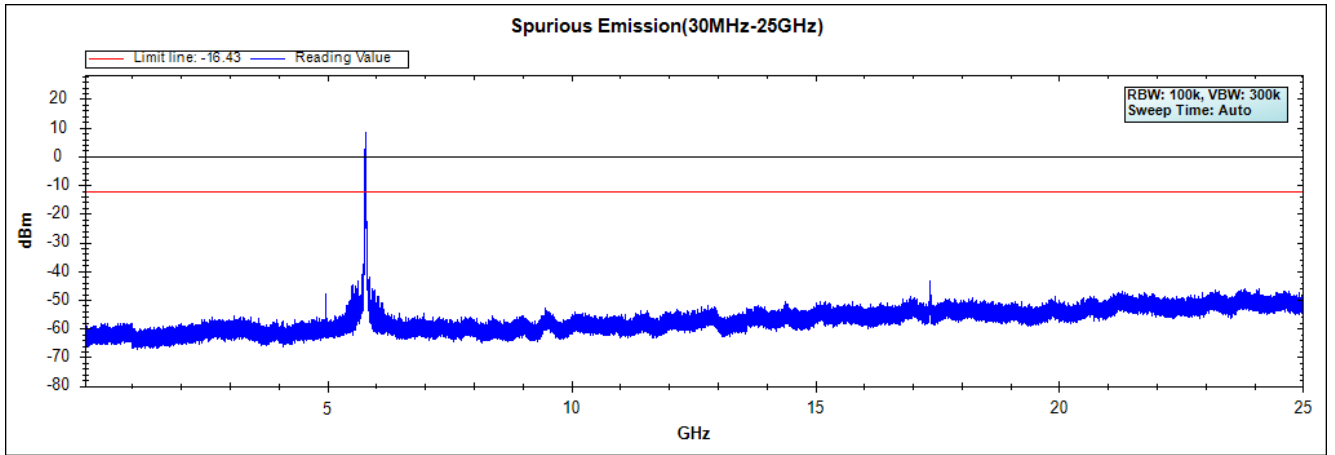

Note: The above test pattern is synthesized by multiple of the frequency range

Channel 165 (5825MHz) 30MHz -40GHz

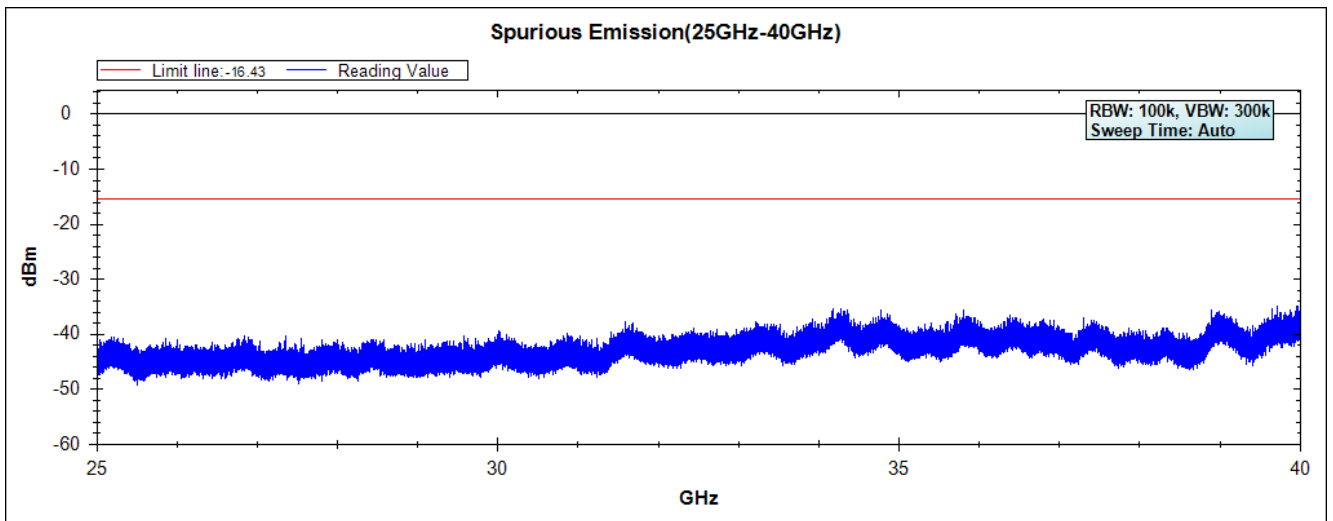
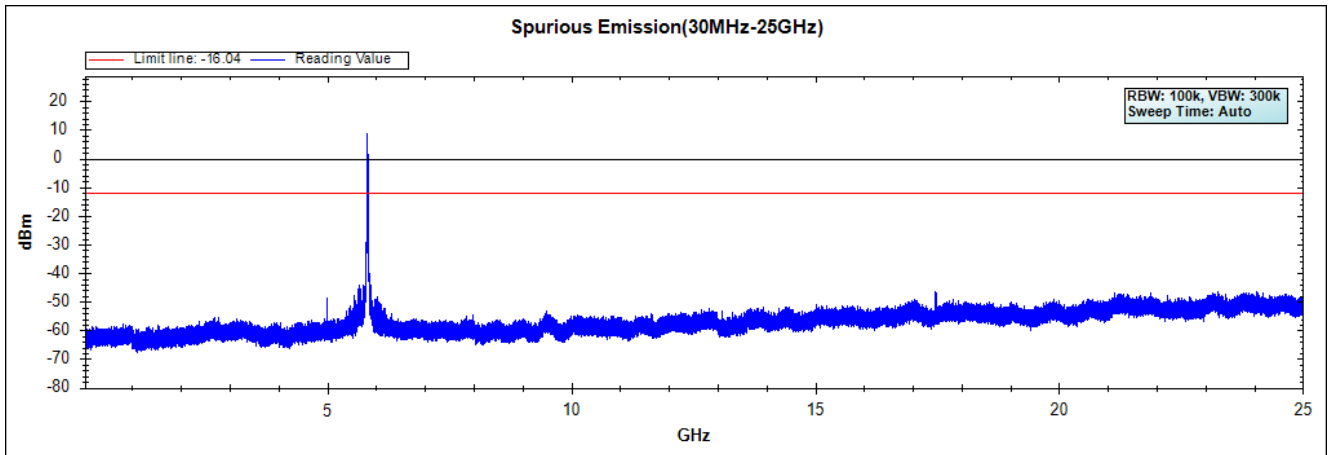

Note: The above test pattern is synthesized by multiple of the frequency range

Product : Intel® Dual Band Wireless-AC 8260  
 Test Item : RF Antenna Conducted Spurious  
 Test Site : No.3 OATS  
 Test Mode : Mode 3 MIMO: Transmit - 802.11n-40BW\_30Mbps(5G Band)

**Chaia A**

**Channel 151 (5755MHz) 30MHz -40GHz**

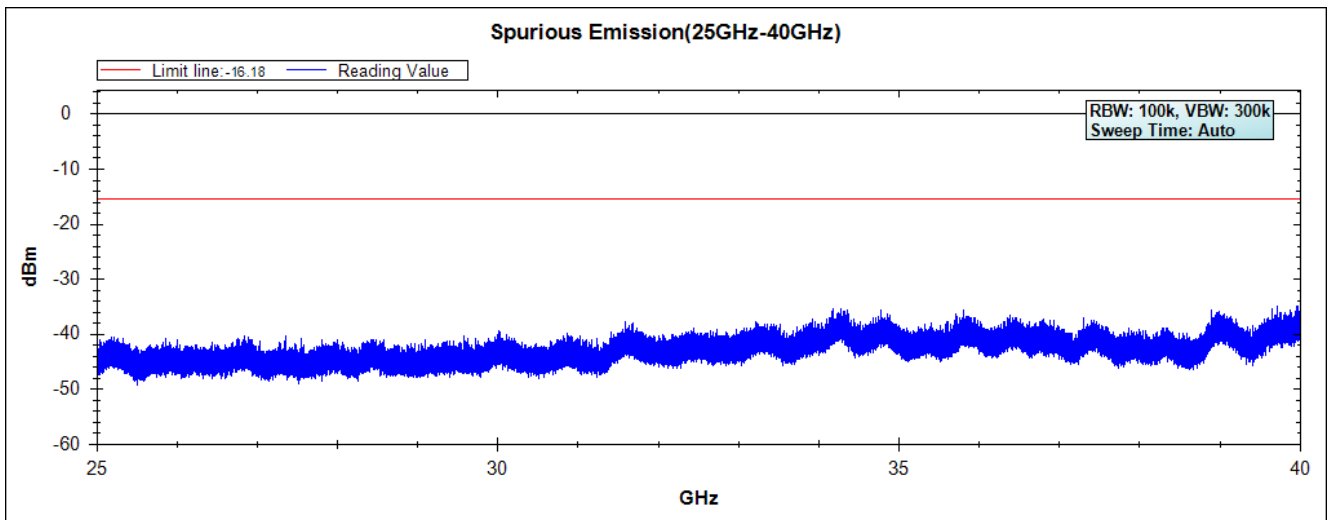
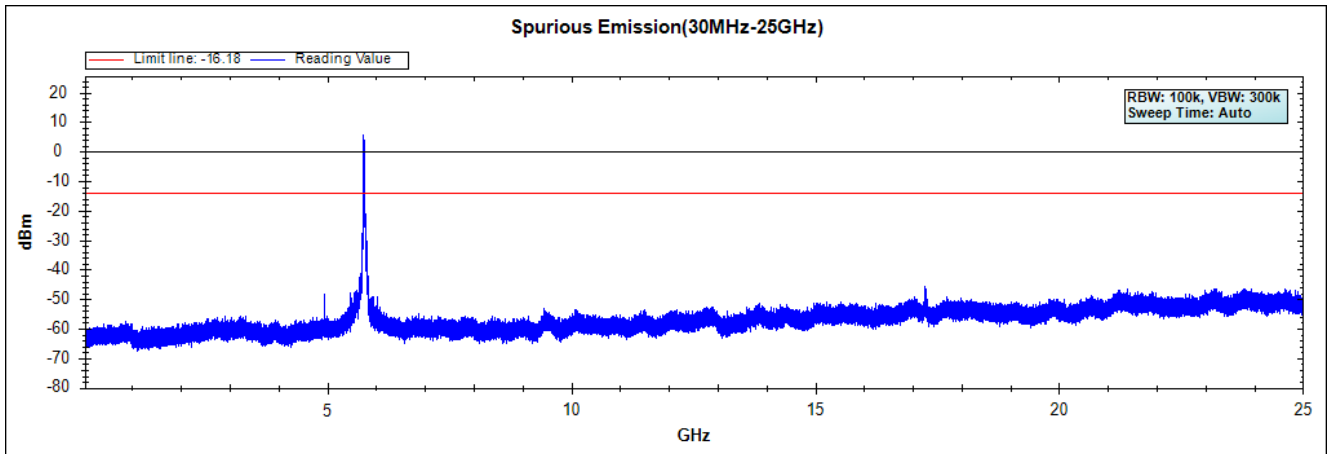

Note: The above test pattern is synthesized by multiple of the frequency range

Channel 159 (5795MHz) 30MHz -40GHz

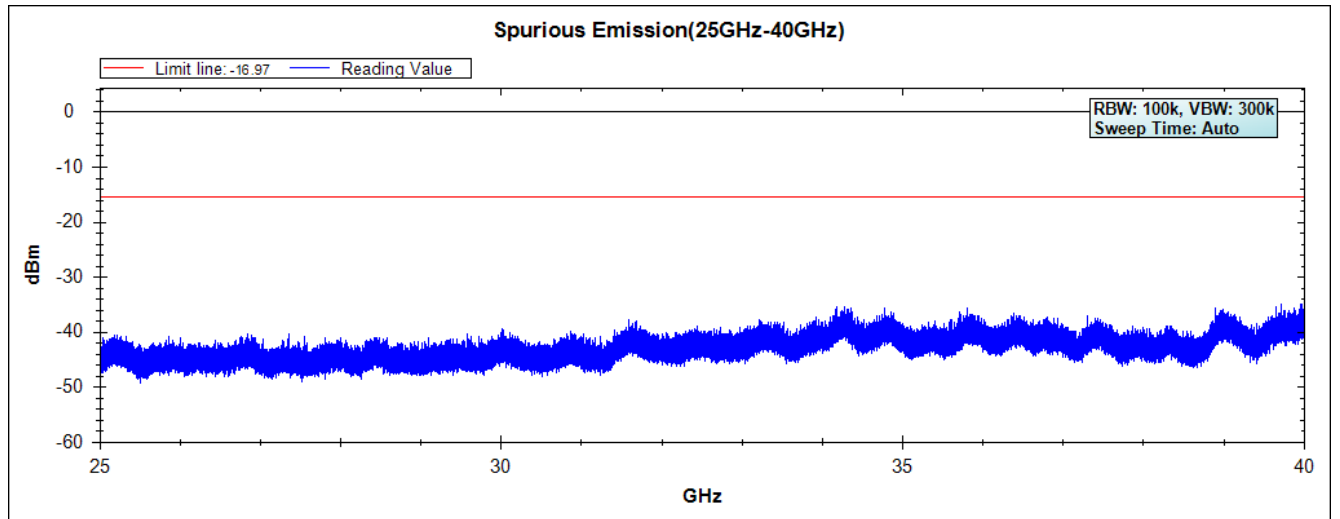
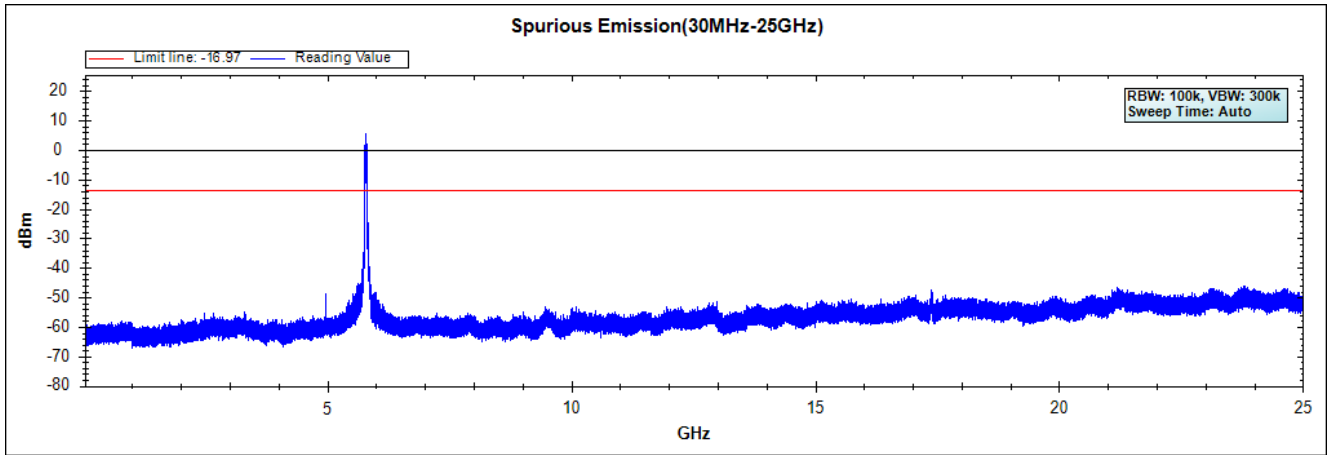

Note: The above test pattern is synthesized by multiple of the frequency range



Product : Intel® Dual Band Wireless-AC 8260  
Test Item : RF Antenna Conducted Spurious  
Test Site : No.3 OATS  
Test Mode : Mode 3 MIMO: Transmit - 802.11ac-80BW\_65Mbps(5G Band)

**Chaia A**

**Channel 155 (5775MHz) 30MHz -40GHz**

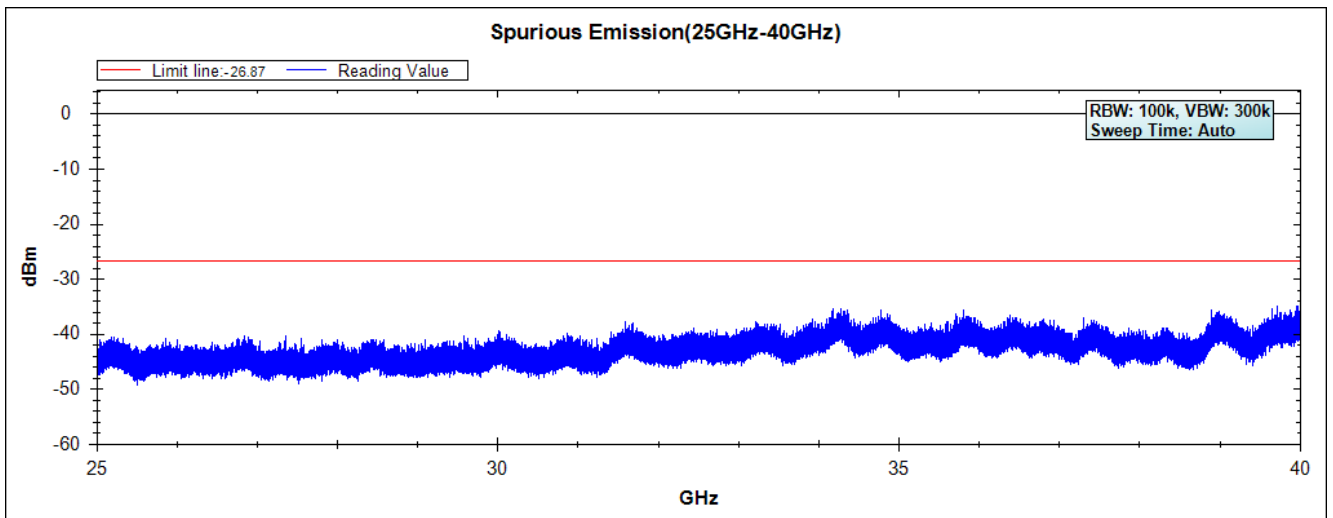
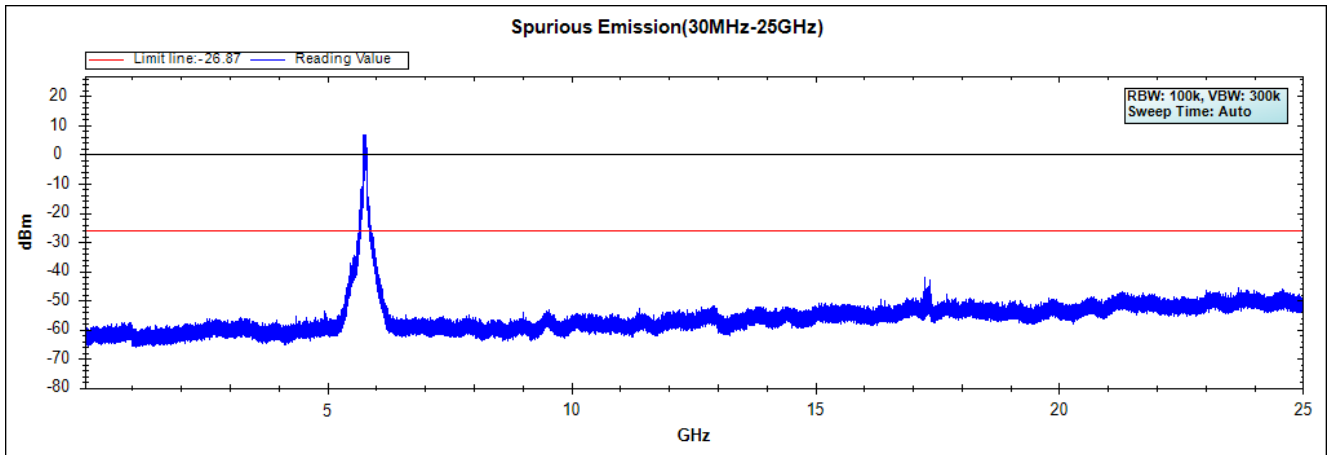

Note: The above test pattern is synthesized by multiple of the frequency range

Product : Intel® Dual Band Wireless-AC 8260  
Test Item : RF Antenna Conducted Spurious  
Test Site : No.3 OATS  
Test Mode : Mode 3 MIMO: Transmit - 802.11n-20BW\_14.4Mbps(2.4G Band)

**Chaia B**

**Channel 01 (2412MHz) 30MHz -25GHz**

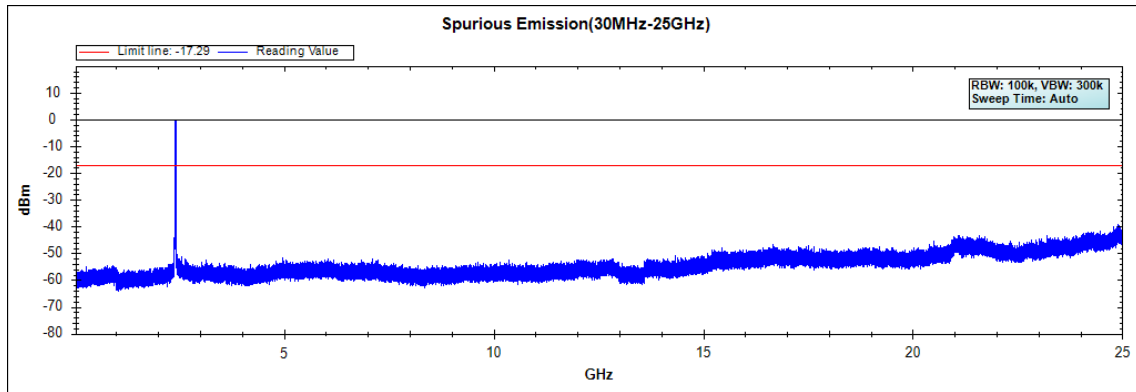

**Channel 06 (2437MHz) 30MHz -25GHz**

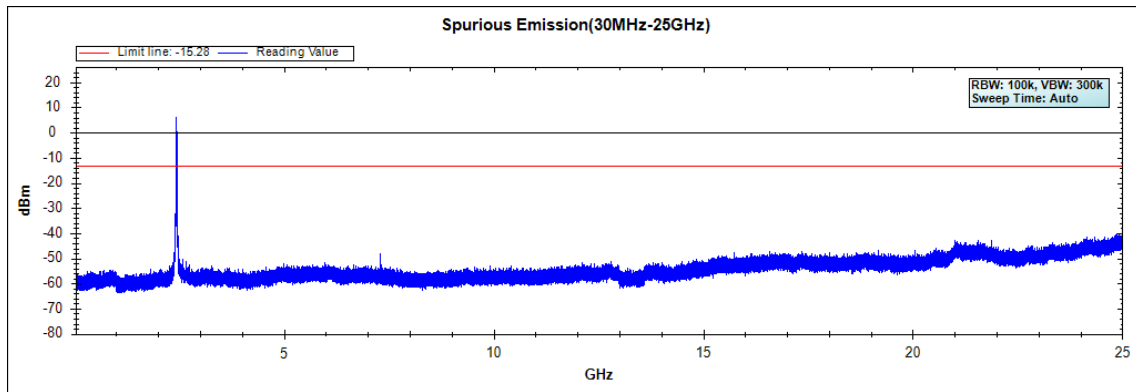

**Channel 11 (2462MHz) 30MHz -25GHz**

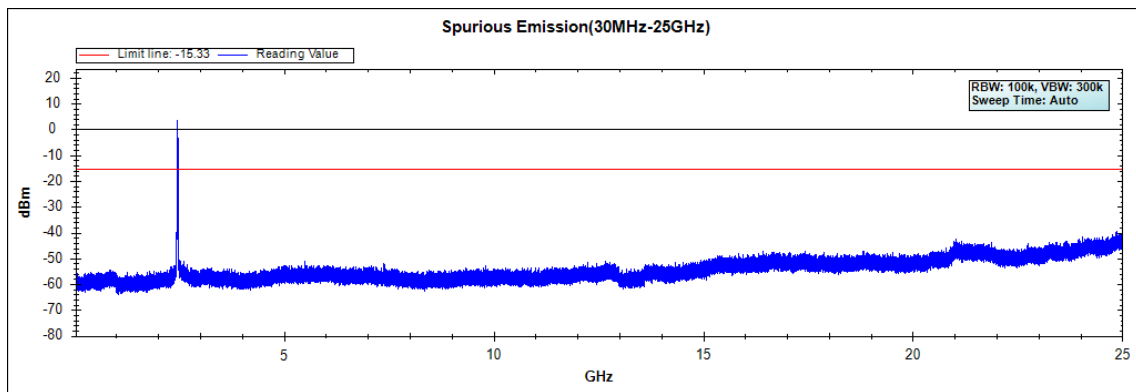

Channel 12 (2467MHz) 30MHz -25GHz

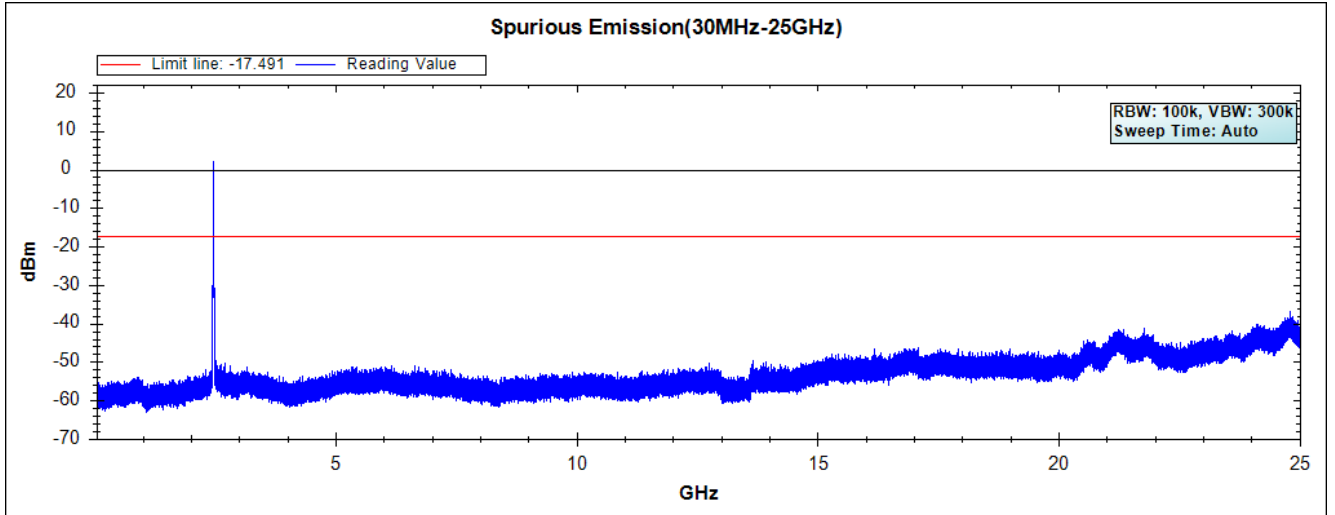

Note: The above test pattern is synthesized by multiple of the frequency range.

Product : Intel® Dual Band Wireless-AC 8260  
Test Item : RF Antenna Conducted Spurious  
Test Site : No.3 OATS  
Test Mode : Mode 3 MIMO: Transmit - 802.11n-40BW\_30Mbps(2.4G Band)

**Chaia B**

**Channel 03 (2422MHz) 30MHz -25GHz**

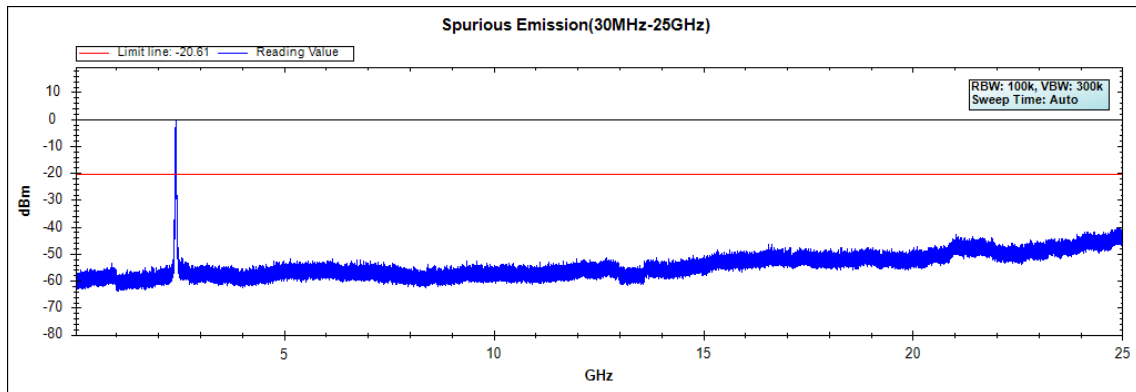

**Channel 06 (2437MHz) 30MHz -25GHz**

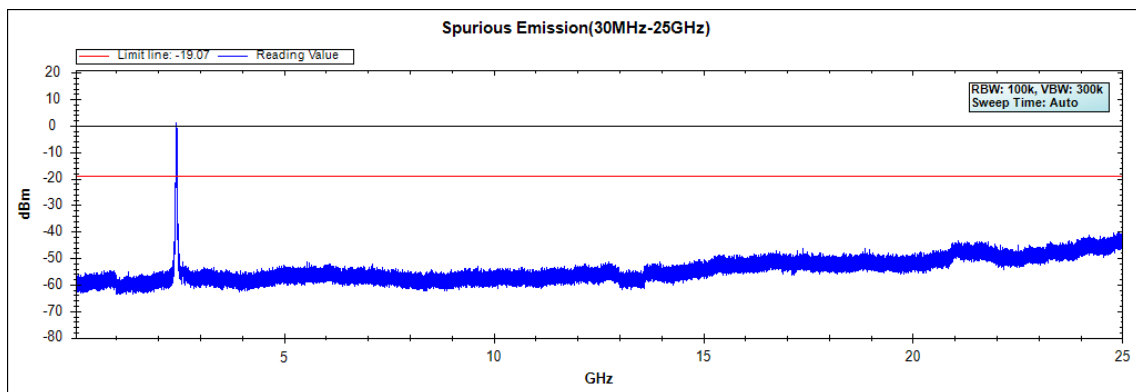

**Channel 09 (2452MHz) 30MHz -25GHz**

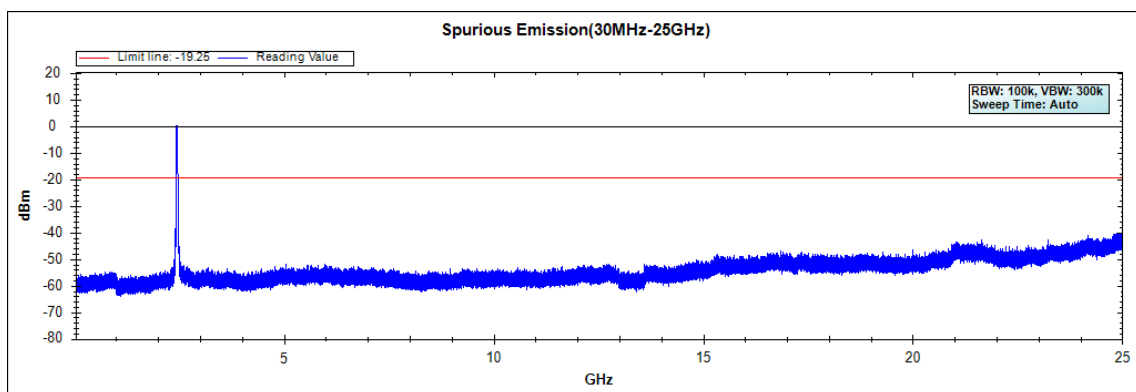

Channel 10 (2457MHz) 30MHz -25GHz

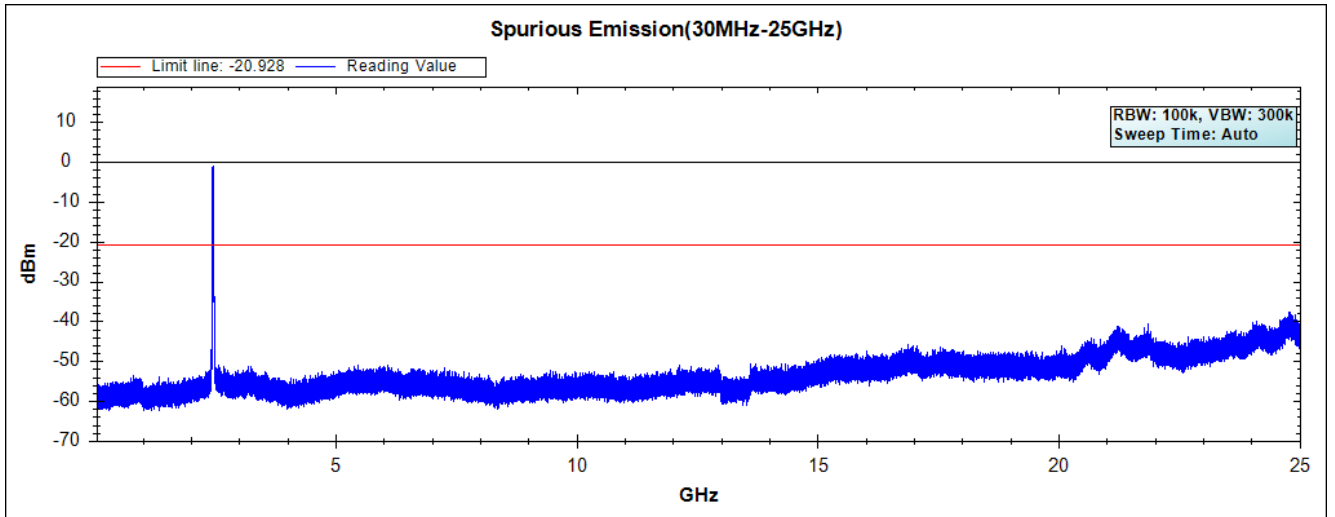

Note: The above test pattern is synthesized by multiple of the frequency range.

Product : Intel® Dual Band Wireless-AC 8260  
Test Item : RF Antenna Conducted Spurious  
Test Site : No.3 OATS  
Test Mode : Mode 3 MIMO: Transmit - 802.11n-20BW\_14.4Mbps(5G Band)

**Chaia B**

**Channel 49 (5745MHz) 30MHz -40GHz**

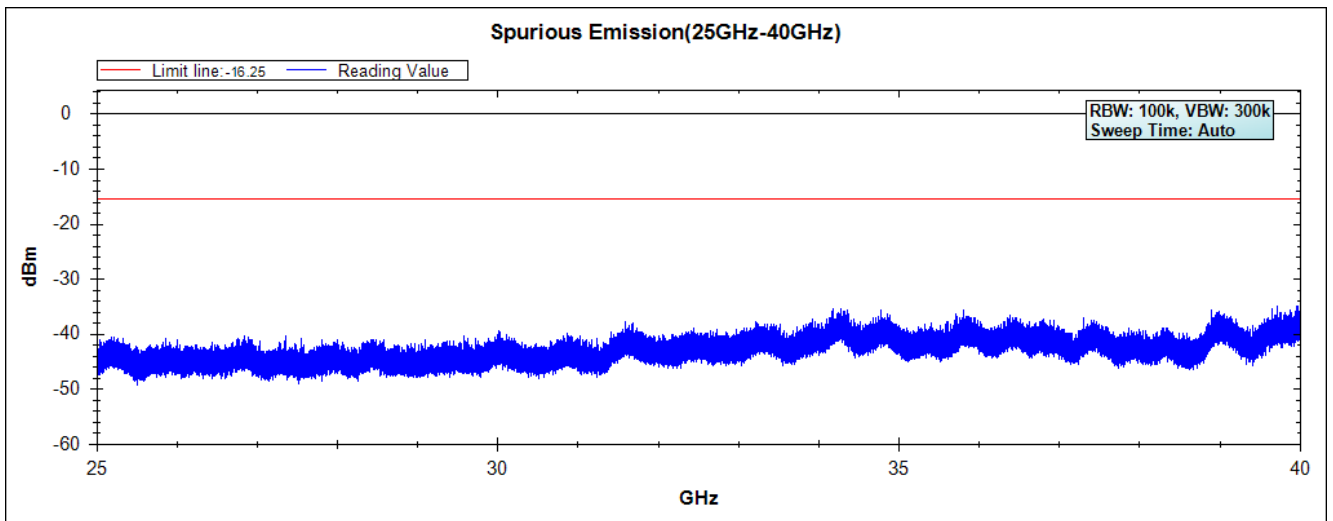
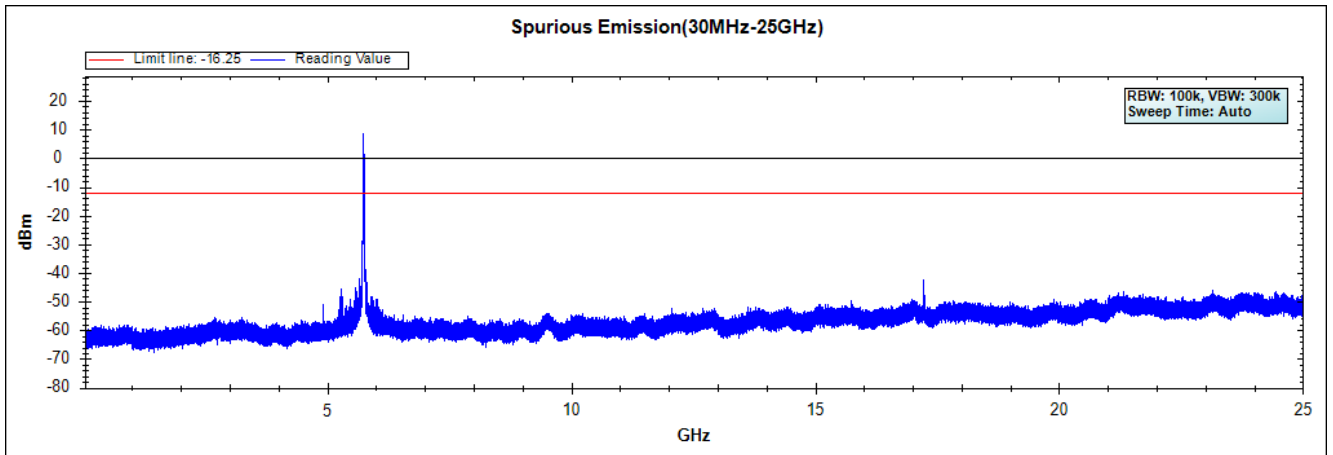

Note: The above test pattern is synthesized by multiple of the frequency range

Channel 157 (5785MHz) 30MHz -40GHz

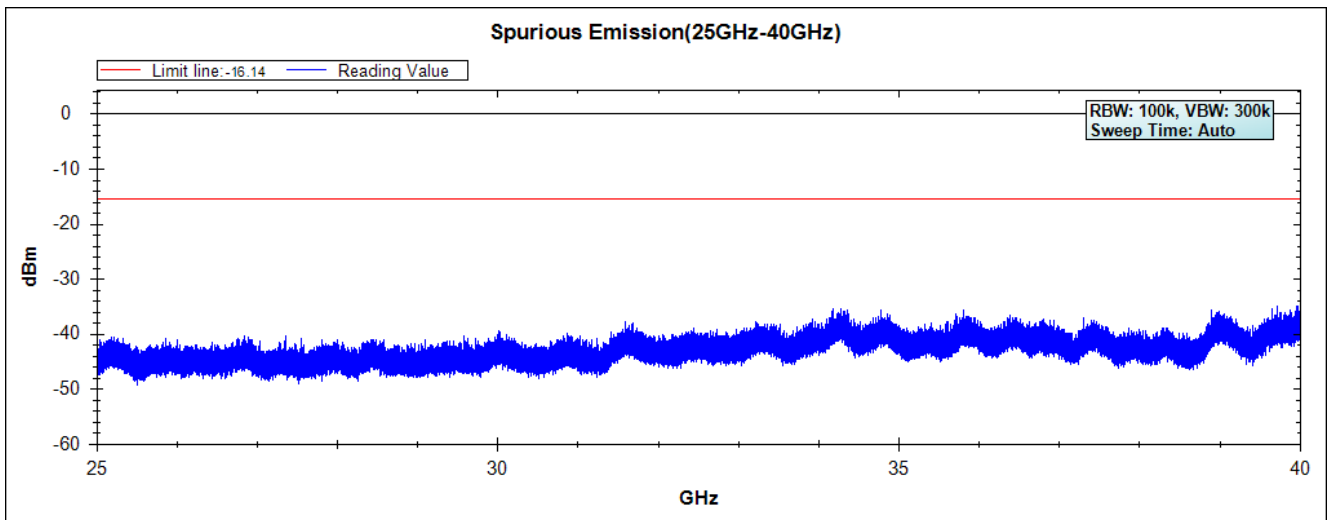
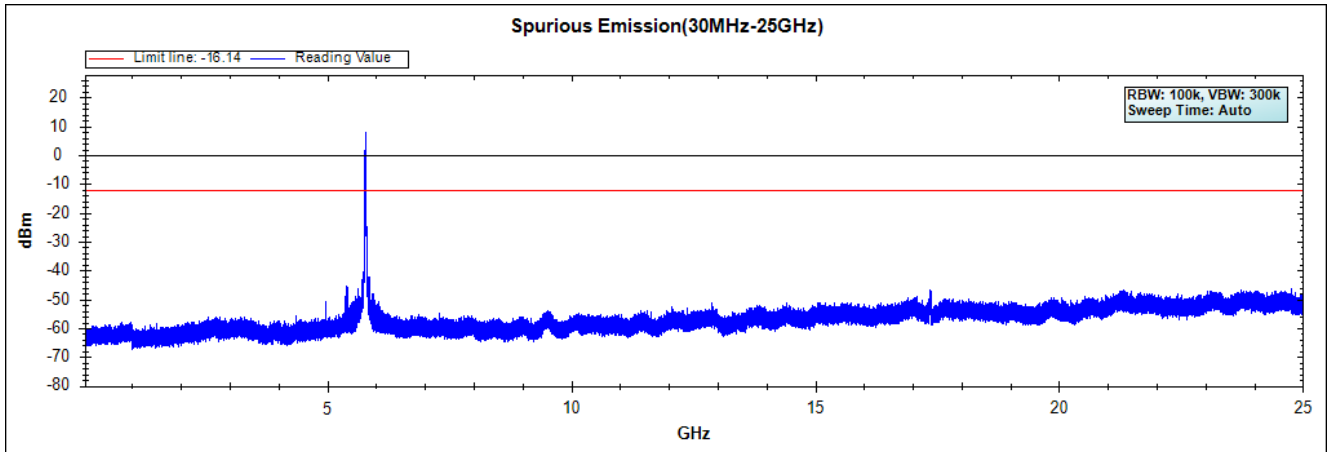

Note: The above test pattern is synthesized by multiple of the frequency range

Channel 165 (5825MHz) 30MHz -40GHz

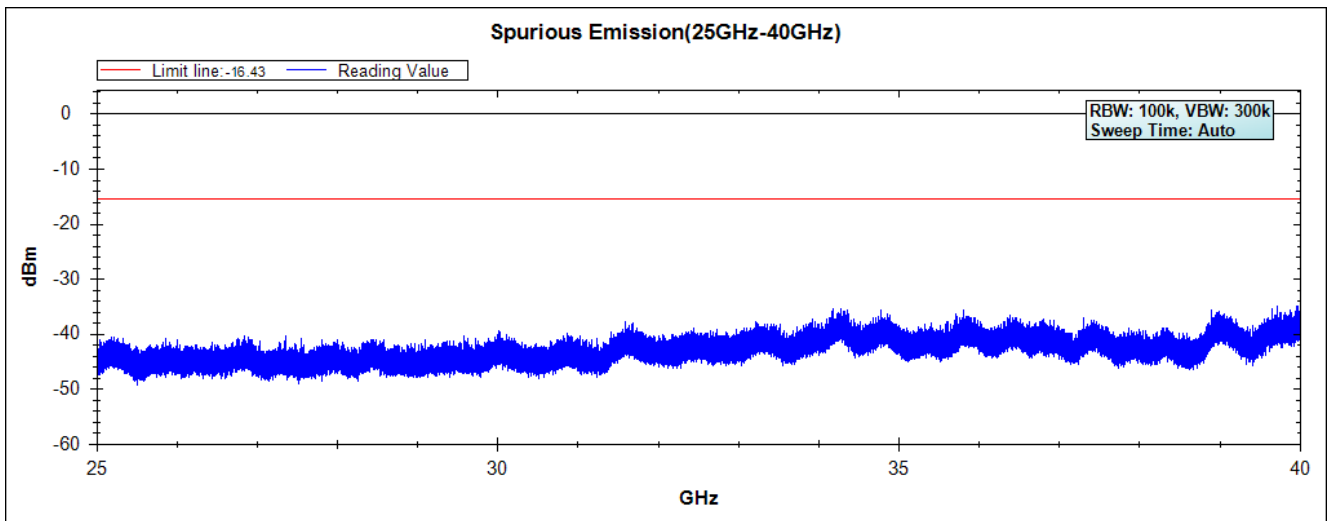
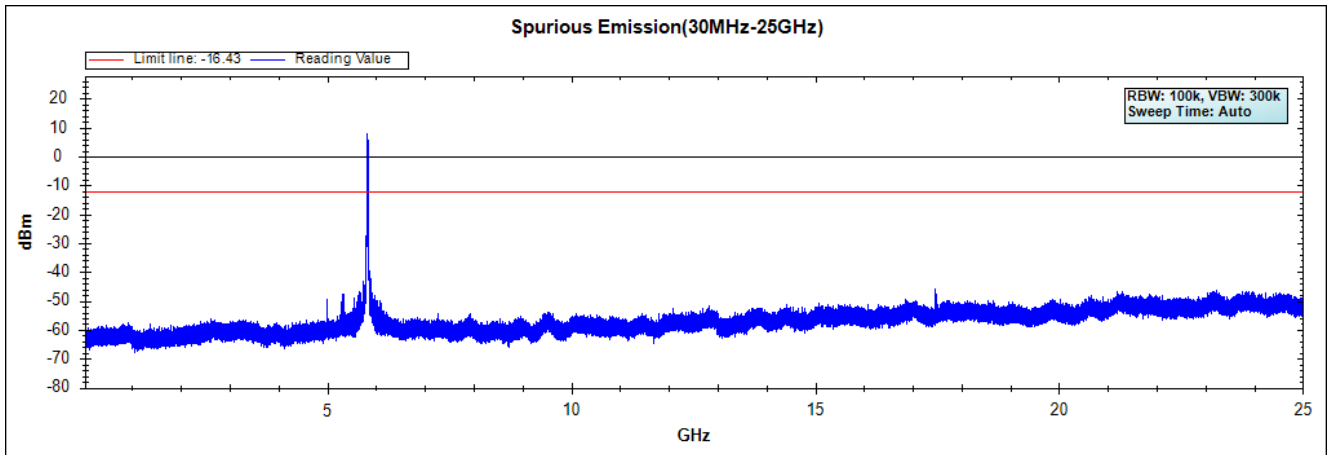

Note: The above test pattern is synthesized by multiple of the frequency range



Product : Intel® Dual Band Wireless-AC 8260  
Test Item : RF Antenna Conducted Spurious  
Test Site : No.3 OATS  
Test Mode : Mode 3 MIMO: Transmit - 802.11n-40BW\_30Mbps(5G Band)

**Chaia B**

**Channel 151 (5755MHz) 30MHz -40GHz**

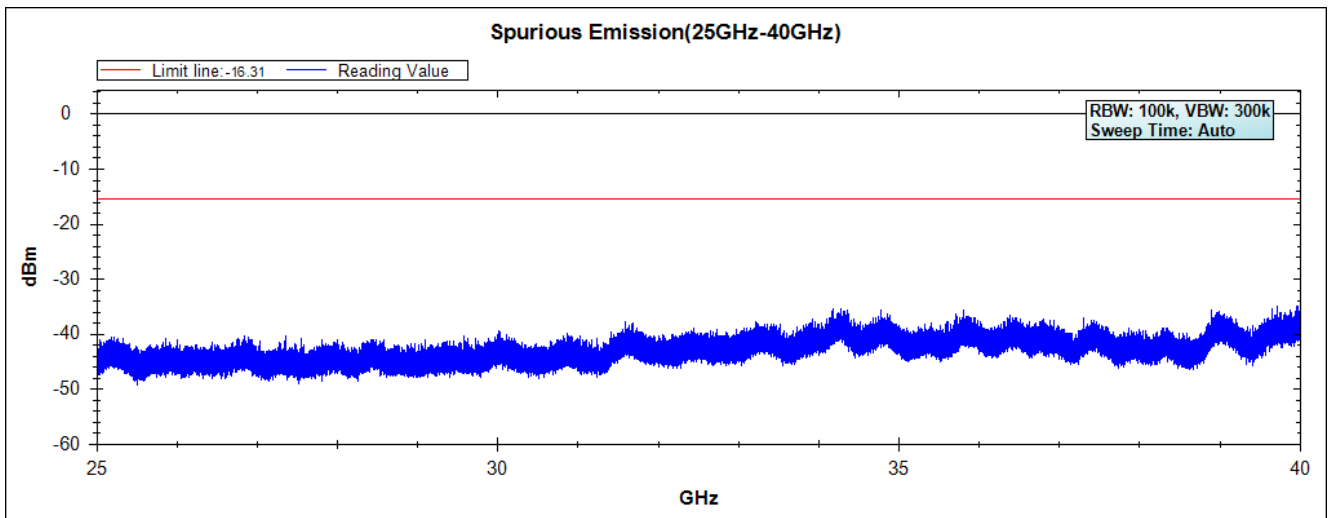
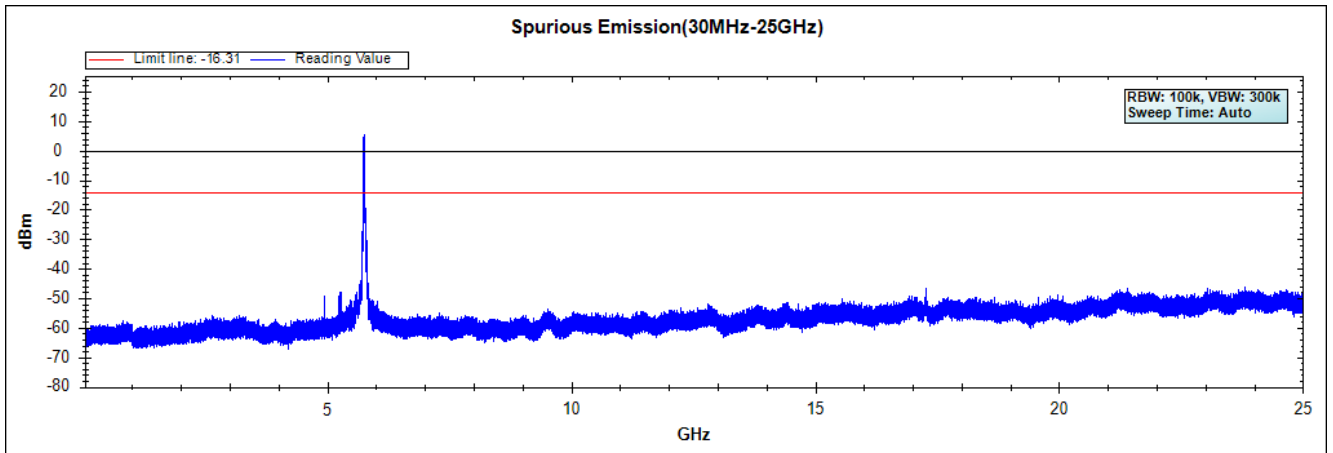

Note: The above test pattern is synthesized by multiple of the frequency range

Channel 159 (5795MHz) 30MHz -40GHz

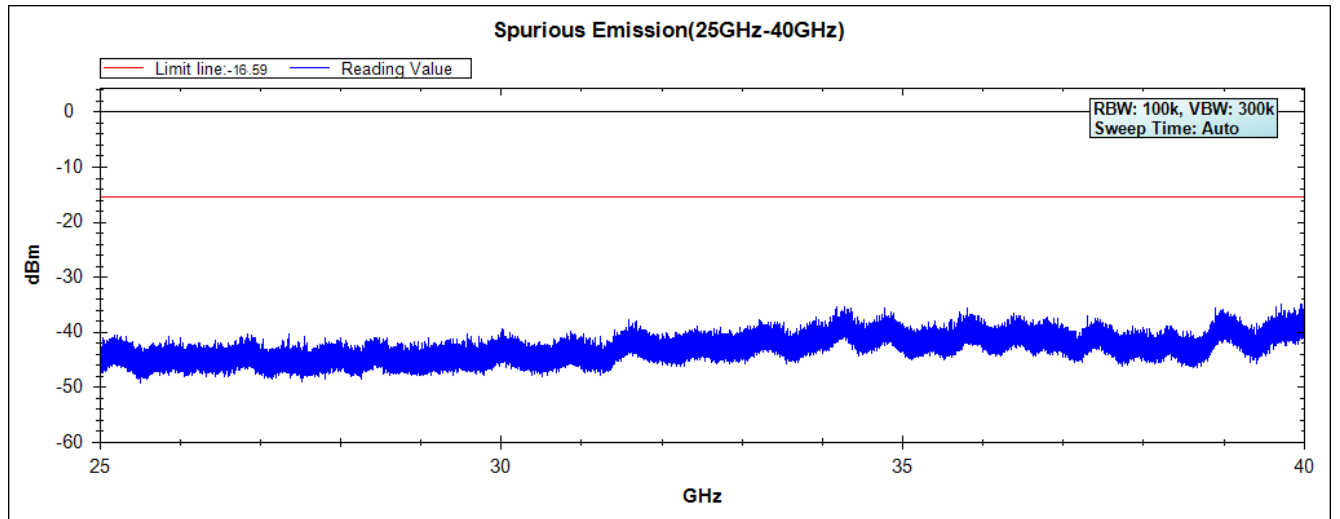
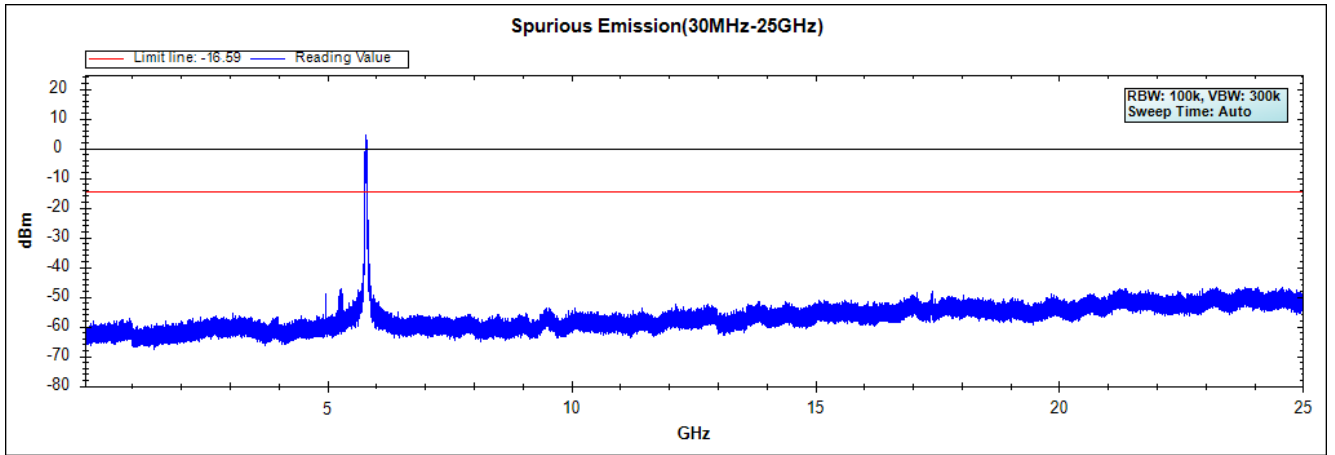

Note: The above test pattern is synthesized by multiple of the frequency range

Product : Intel® Dual Band Wireless-AC 8260  
Test Item : RF Antenna Conducted Spurious  
Test Site : No.3 OATS  
Test Mode : Mode 3 MIMO: Transmit - 802.11ac-80BW\_65Mbps(5G Band)

**Chaia B**

**Channel 155 (5775MHz) 30MHz -40GHz**

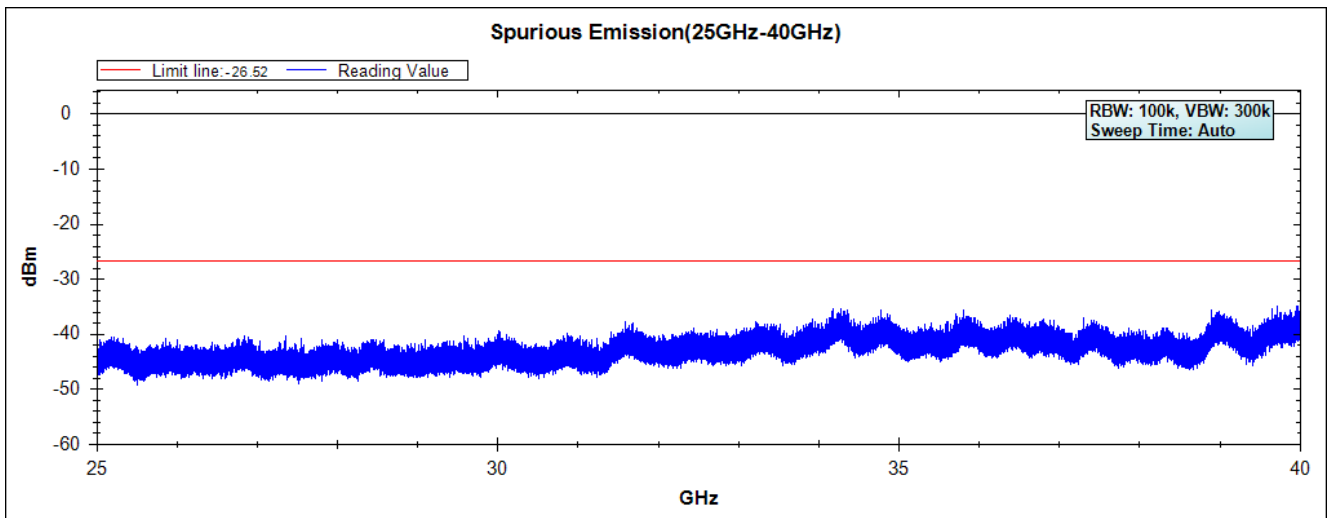
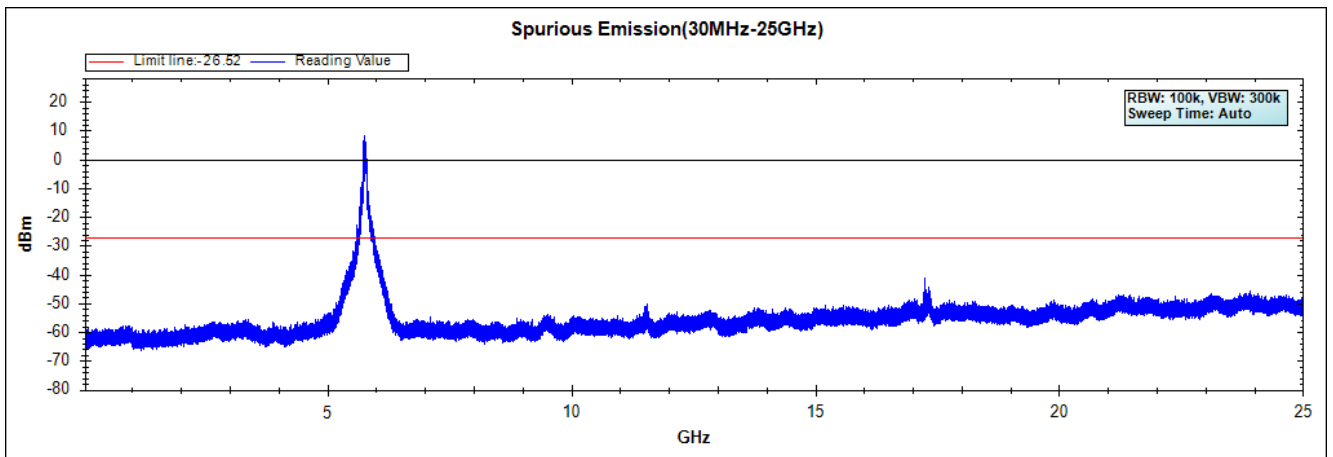

Note: The above test pattern is synthesized by multiple of the frequency range

Product : Intel® Dual Band Wireless-AC 8260  
 Test Item : RF Antenna Conducted Spurious  
 Test Site : No.3 OATS  
 Test Mode : Mode 4 Beamforming: Transmit - 802.11n-20BW\_14.4Mbps(2.4G Band)

**Chaia A**

**Channel 01 (2412MHz) 30MHz -25GHz**

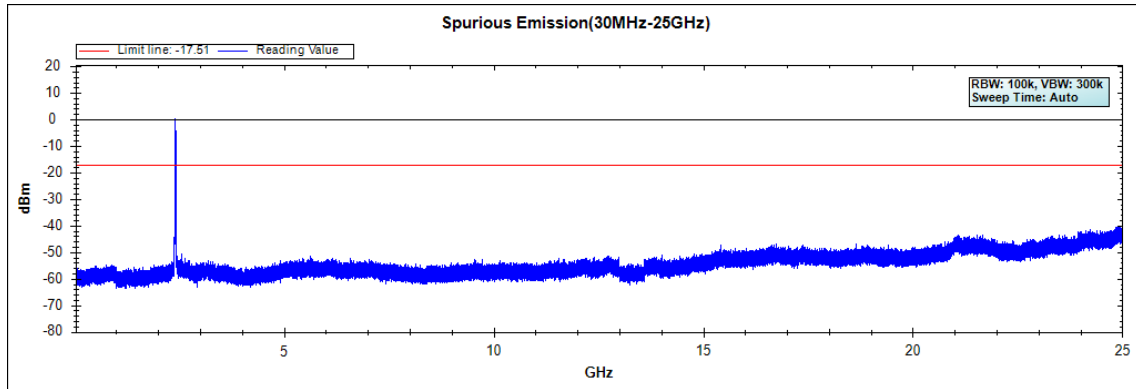

**Channel 06 (2437MHz) 30MHz -25GHz**

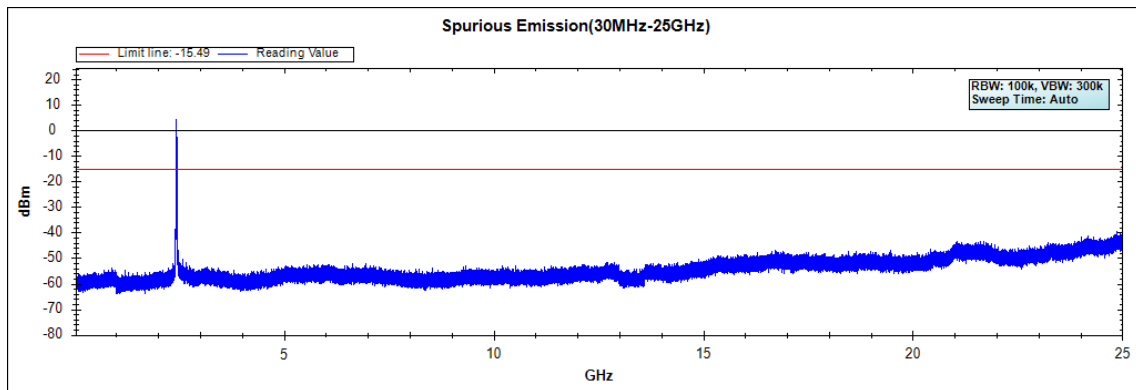

**Channel 11 (2462MHz) 30MHz -25GHz**

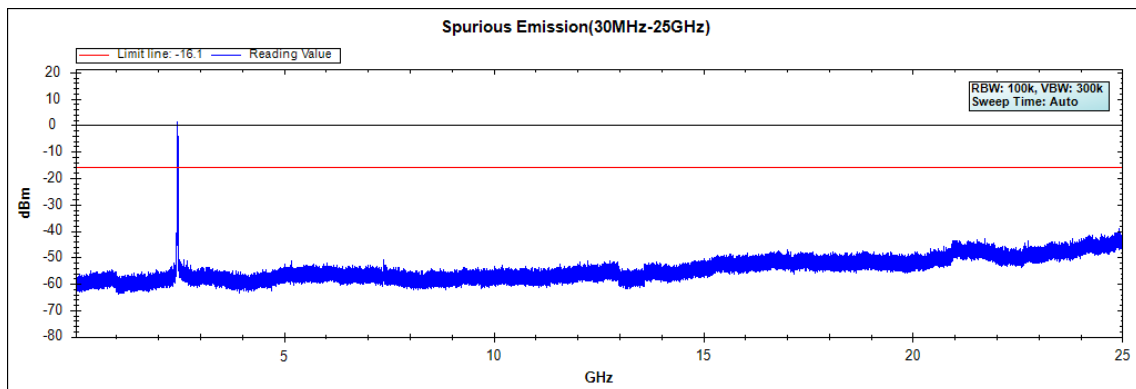

Channel 12 (2467MHz) 30MHz -25GHz

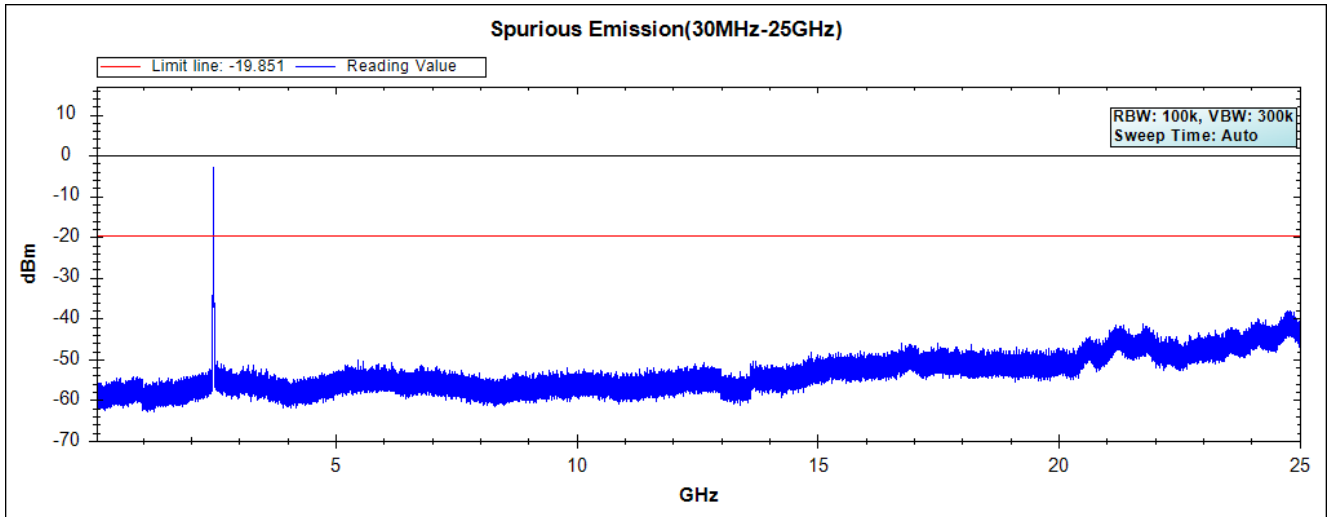

Note: The above test pattern is synthesized by multiple of the frequency range.

Product : Intel® Dual Band Wireless-AC 8260  
Test Item : RF Antenna Conducted Spurious  
Test Site : No.3 OATS  
Test Mode : Mode 4 Beamforming: Transmit - 802.11n-40BW\_30Mbps(2.4G Band)

**Chaia A**

**Channel 03 (2422MHz) 30MHz -25GHz**

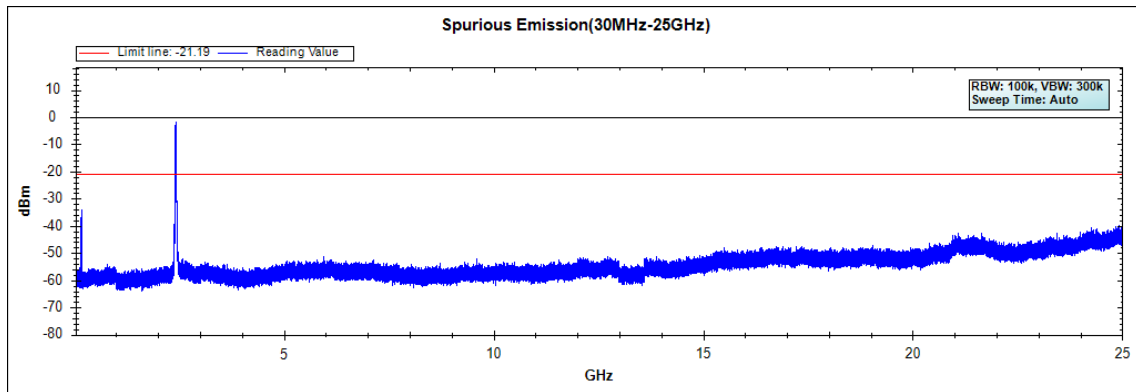

**Channel 06 (2437MHz) 30MHz -25GHz**

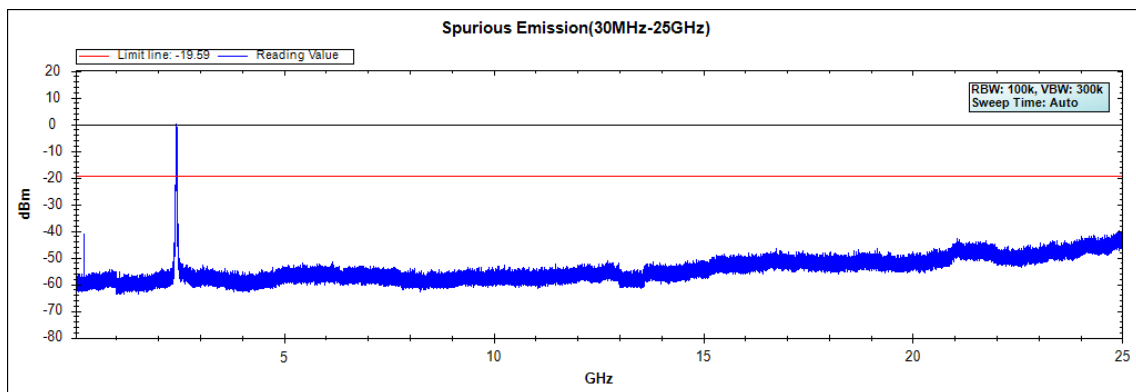

**Channel 09 (2452MHz) 30MHz -25GHz**

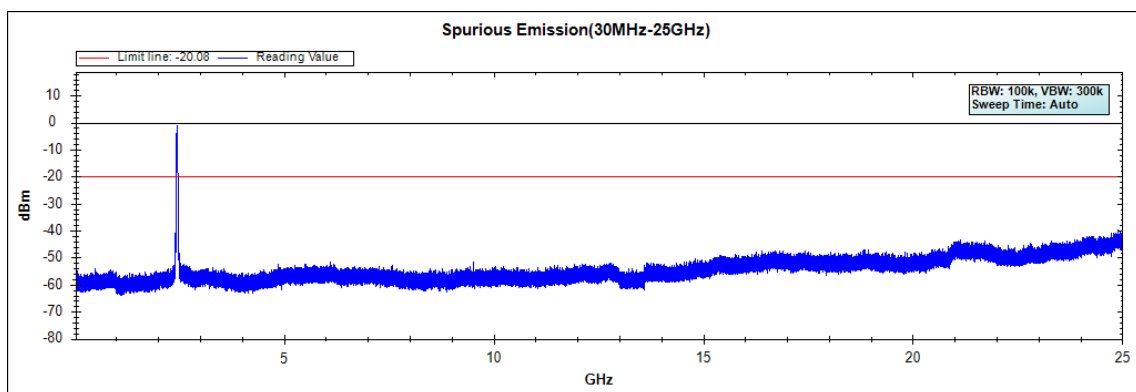

Channel 10 (2457MHz) 30MHz -25GHz

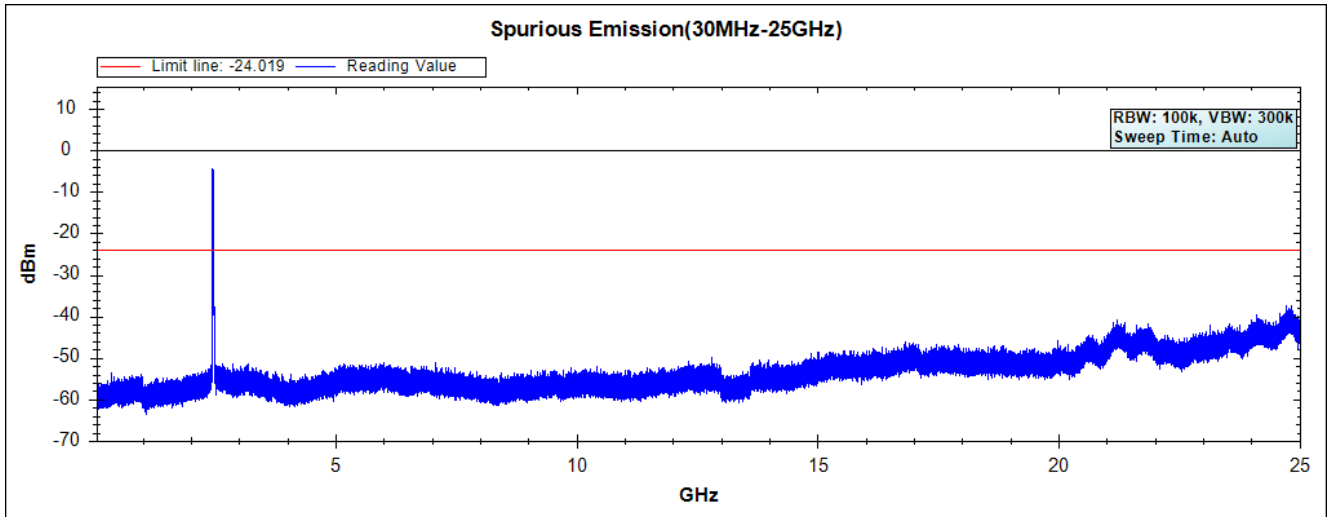

Note: The above test pattern is synthesized by multiple of the frequency range.

Product : Intel® Dual Band Wireless-AC 8260  
Test Item : RF Antenna Conducted Spurious  
Test Site : No.3 OATS  
Test Mode : Mode 4 Beamforming: Transmit - 802.11n-20BW\_14.4Mbps(5G Band)

**Chaia A**

**Channel 49 (5745MHz) 30MHz -40GHz**

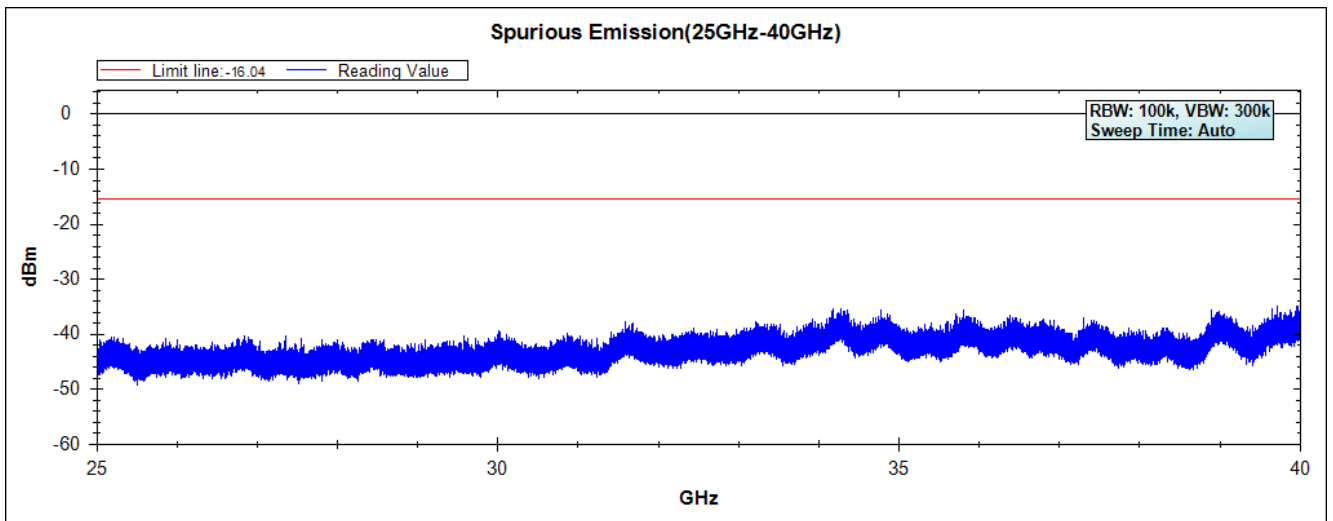
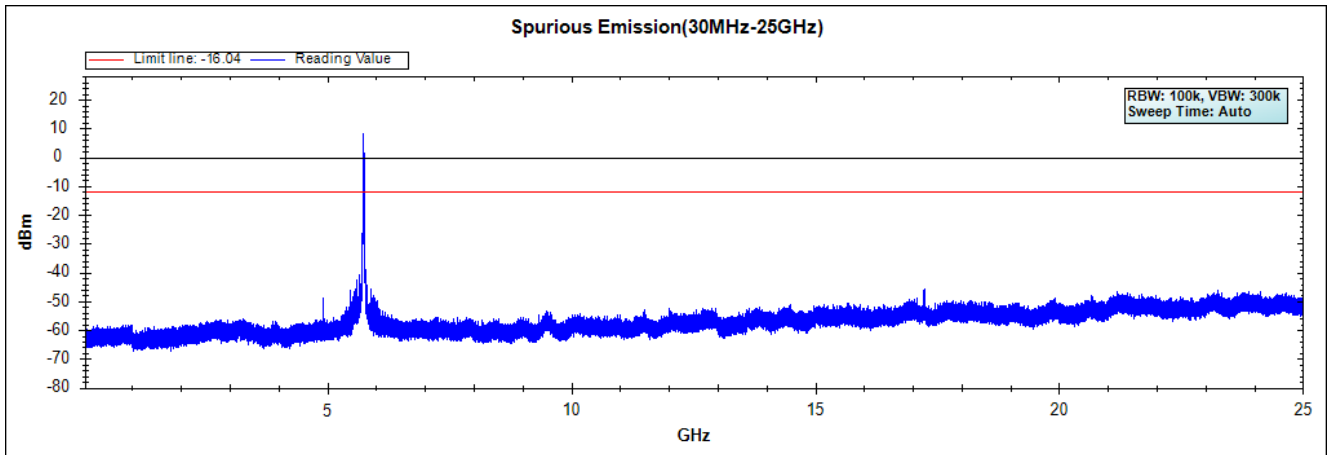

Note: The above test pattern is synthesized by multiple of the frequency range



Channel 157 (5785MHz) 30MHz -40GHz

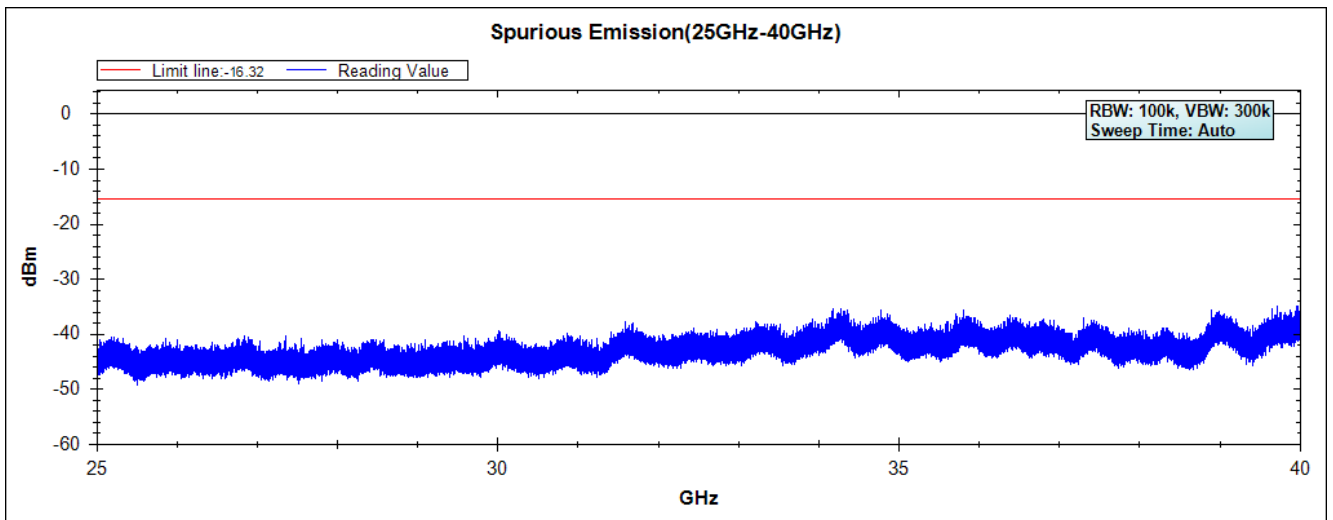
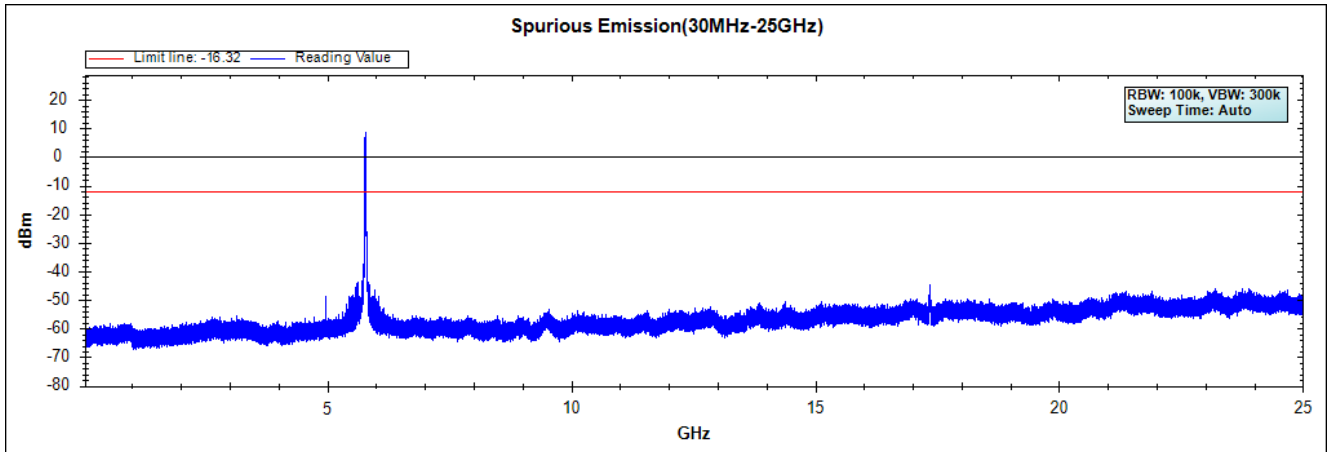

Note: The above test pattern is synthesized by multiple of the frequency range

Channel 165 (5825MHz) 30MHz -40GHz

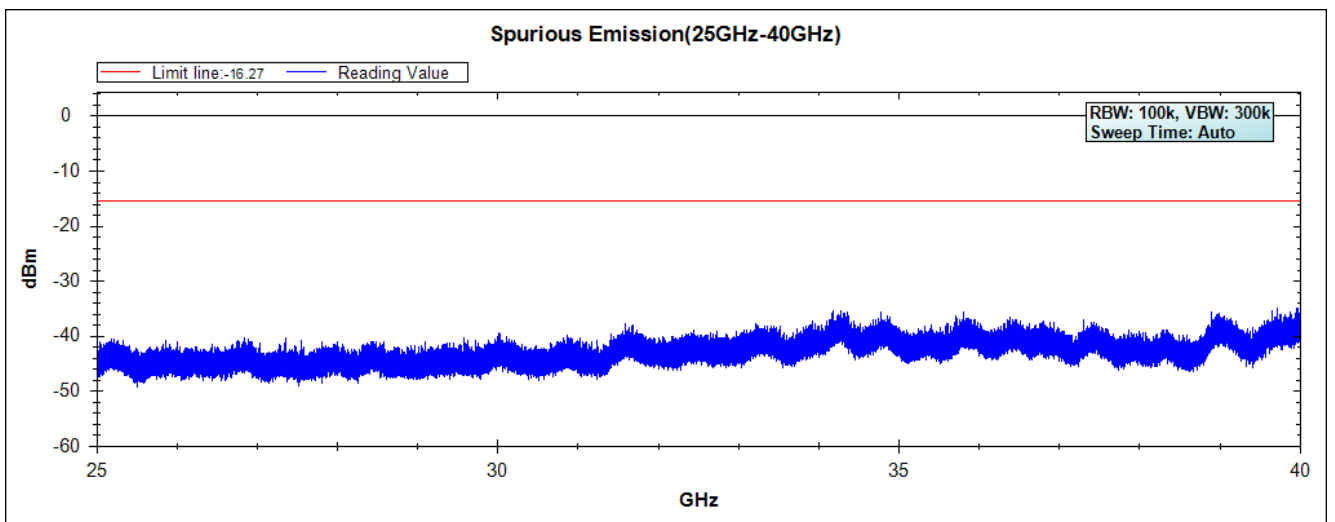
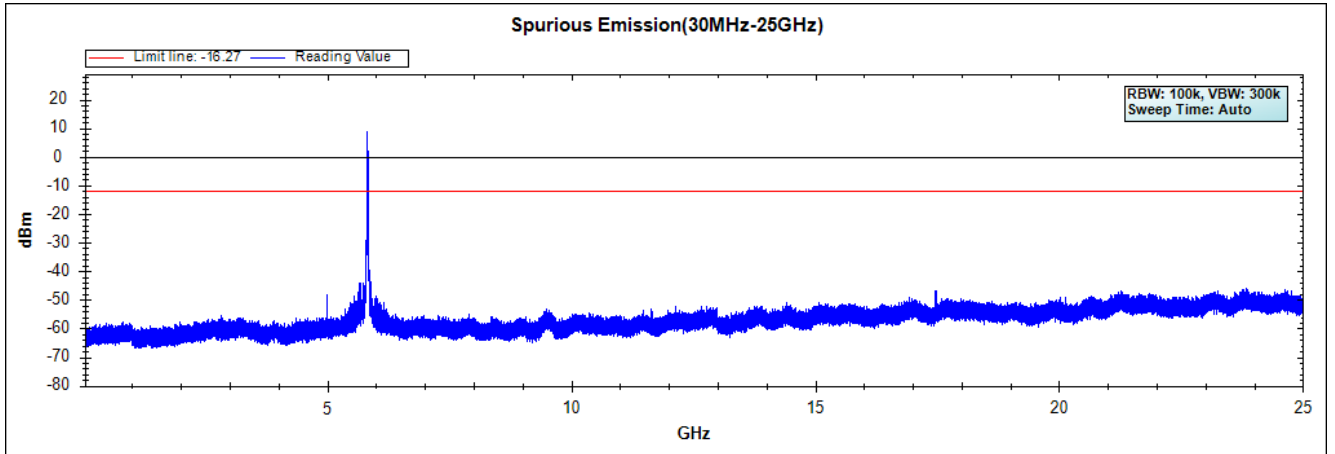

Note: The above test pattern is synthesized by multiple of the frequency range

Product : Intel® Dual Band Wireless-AC 8260  
Test Item : RF Antenna Conducted Spurious  
Test Site : No.3 OATS  
Test Mode : Mode 4 Beamforming: Transmit - 802.11n-40BW\_30Mbps(5G Band)

**Chaia A**

**Channel 151 (5755MHz) 30MHz -40GHz**

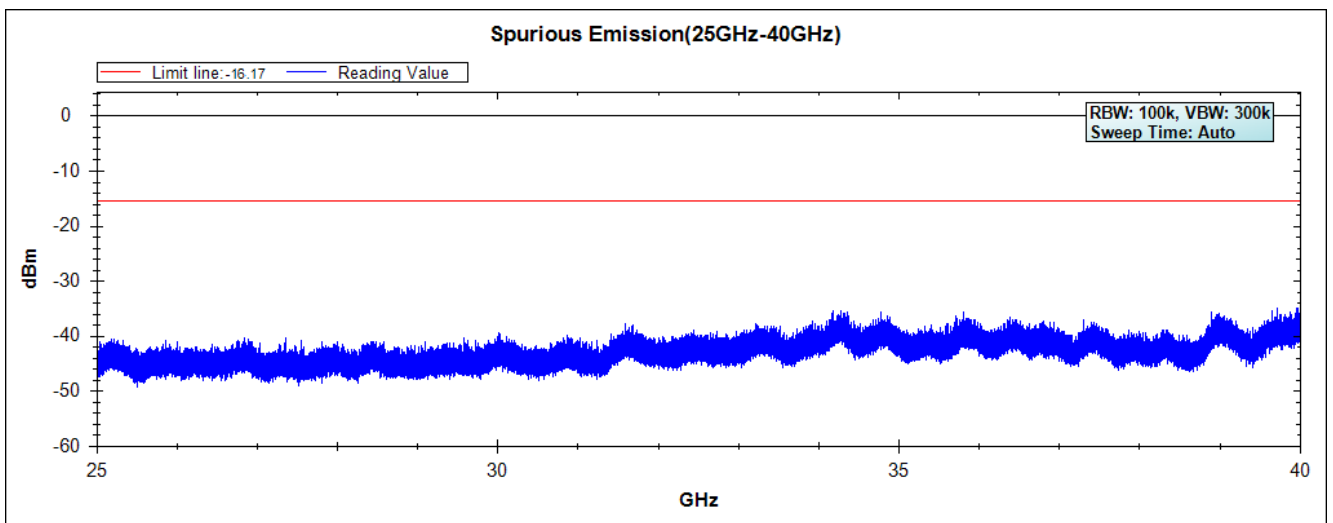
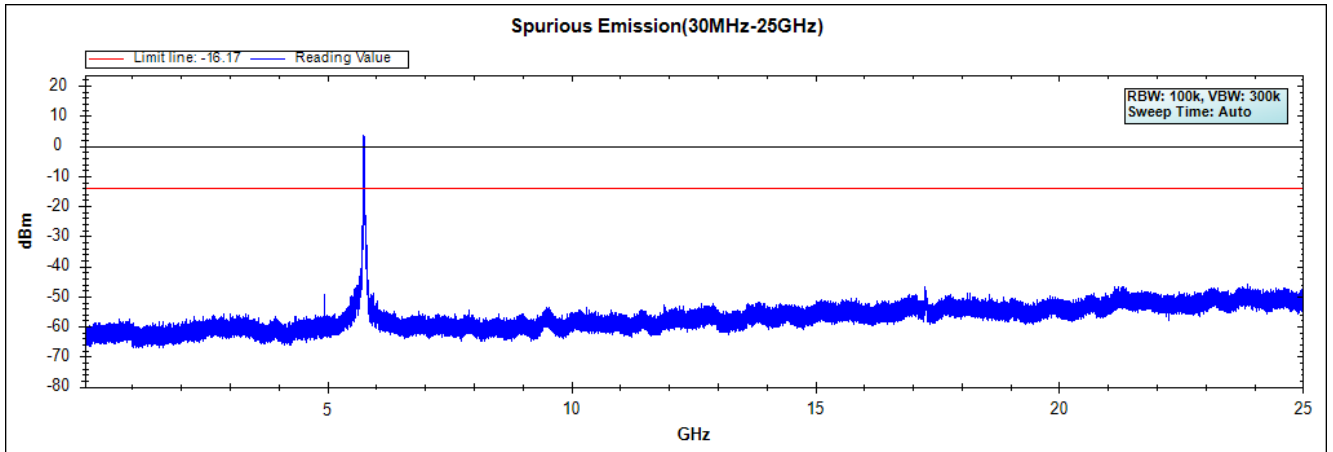

Note: The above test pattern is synthesized by multiple of the frequency range

Channel 159 (5795MHz) 30MHz -40GHz

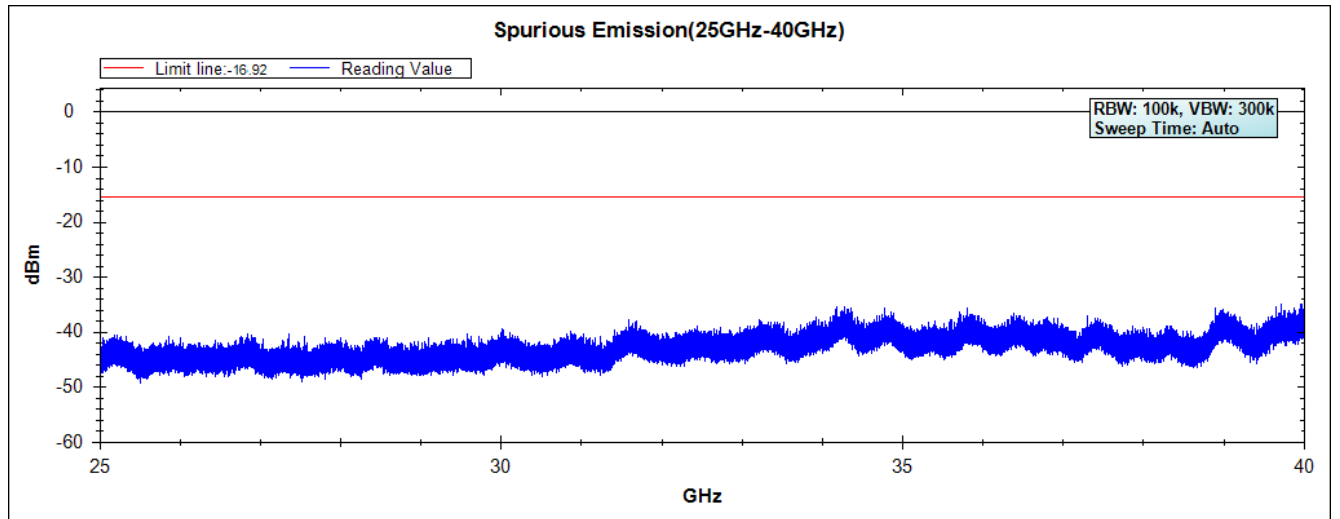
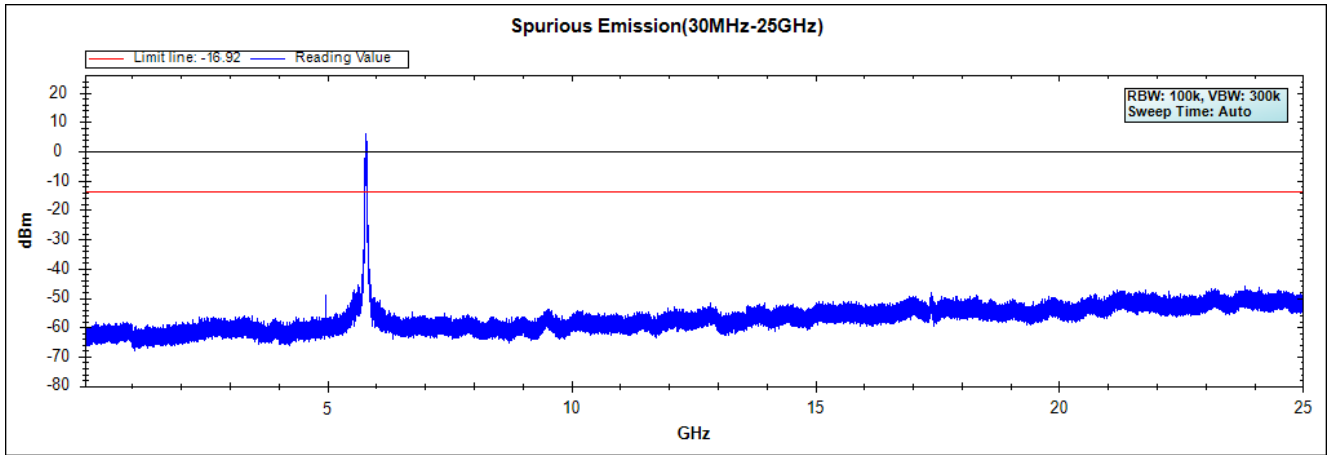

Note: The above test pattern is synthesized by multiple of the frequency range

Product : Intel® Dual Band Wireless-AC 8260  
 Test Item : RF Antenna Conducted Spurious  
 Test Site : No.3 OATS  
 Test Mode : Mode 4 Beamforming: Transmit - 802.11ac-80BW\_65Mbps(5G Band)

**Chaia A**

**Channel 155 (5775MHz) 30MHz -40GHz**

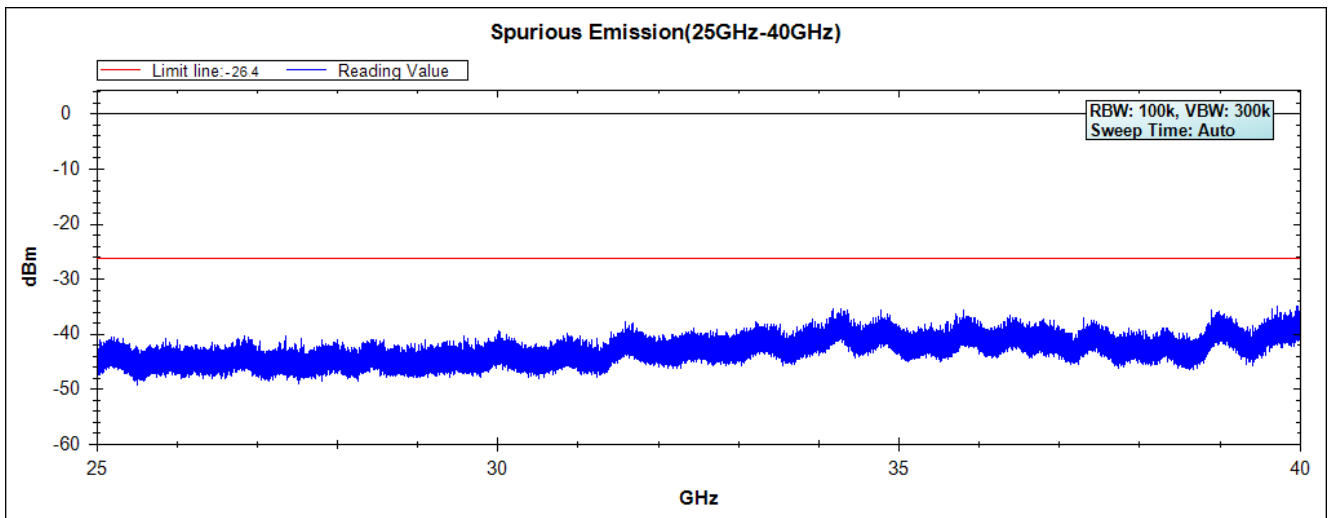
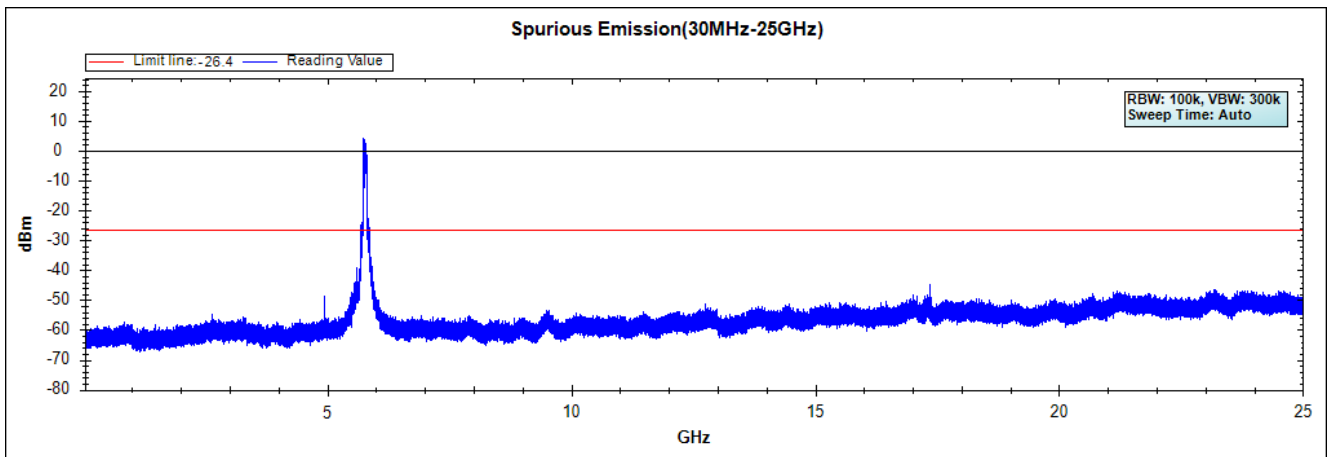

Note: The above test pattern is synthesized by multiple of the frequency range

Product : Intel® Dual Band Wireless-AC 8260  
 Test Item : RF Antenna Conducted Spurious  
 Test Site : No.3 OATS  
 Test Mode : Mode 4 Beamforming: Transmit - 802.11n-20BW\_14.4Mbps(2.4G Band)

**Chaia B**

**Channel 01 (2412MHz) 30MHz -25GHz**

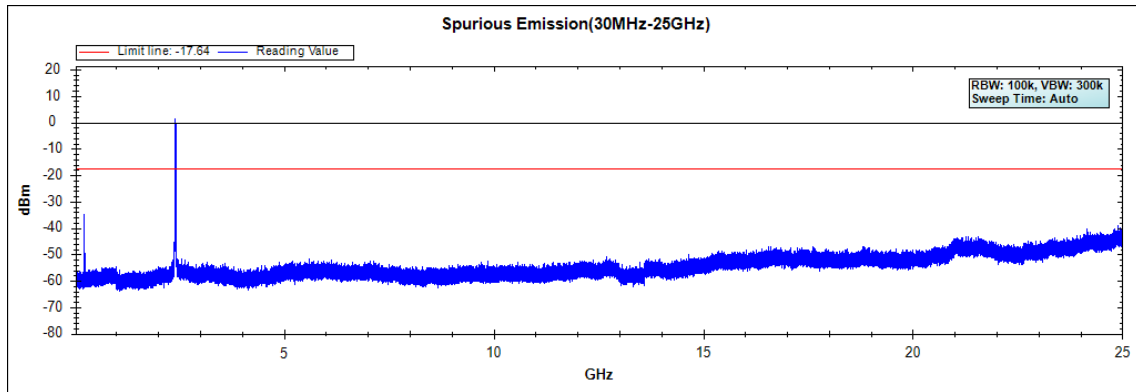

**Channel 06 (2437MHz) 30MHz -25GHz**

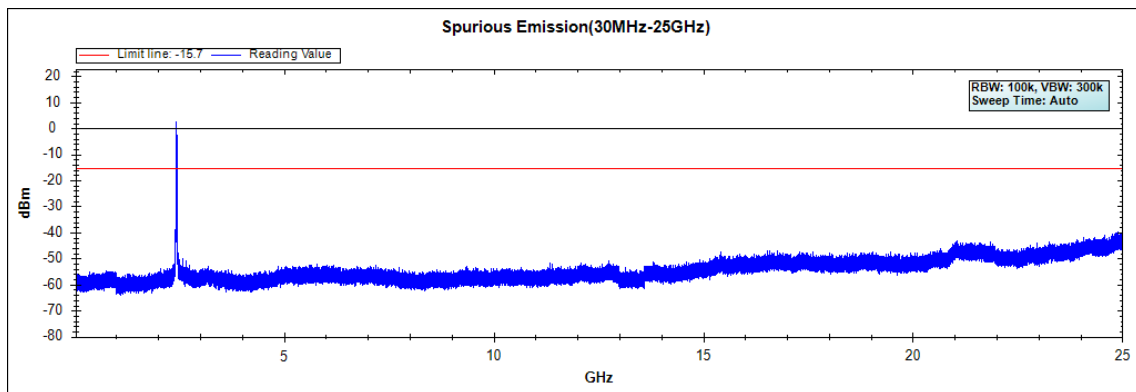

**Channel 11 (2462MHz) 30MHz -25GHz**

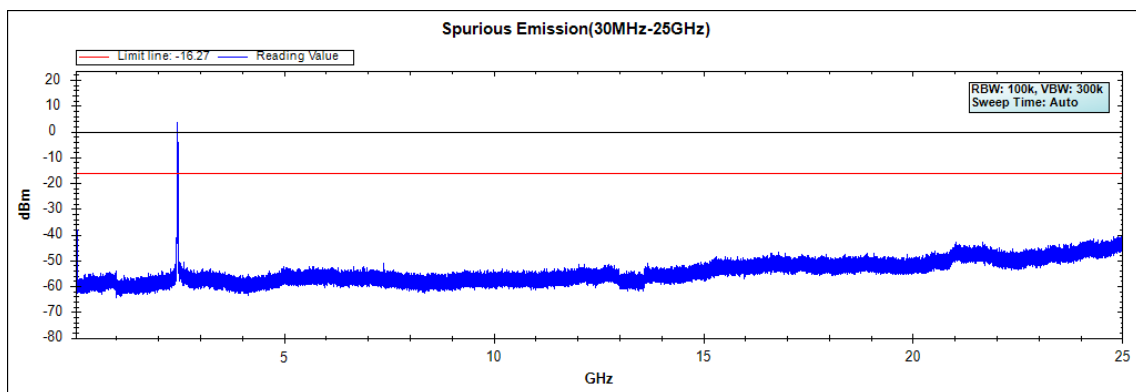

Channel 12 (2467MHz) 30MHz -25GHz

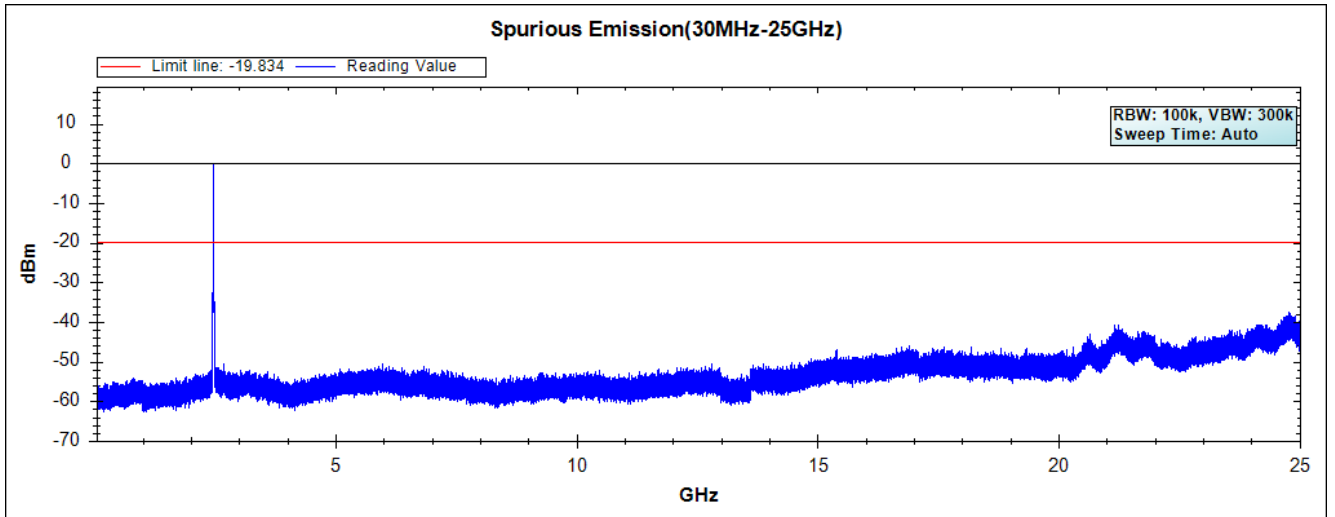

Note: The above test pattern is synthesized by multiple of the frequency range.

Product : Intel® Dual Band Wireless-AC 8260  
Test Item : RF Antenna Conducted Spurious  
Test Site : No.3 OATS  
Test Mode : Mode 4 Beamforming: Transmit - 802.11n-40BW\_30Mbps(2.4G Band)

**Chaia B**

**Channel 03 (2422MHz) 30MHz -25GHz**

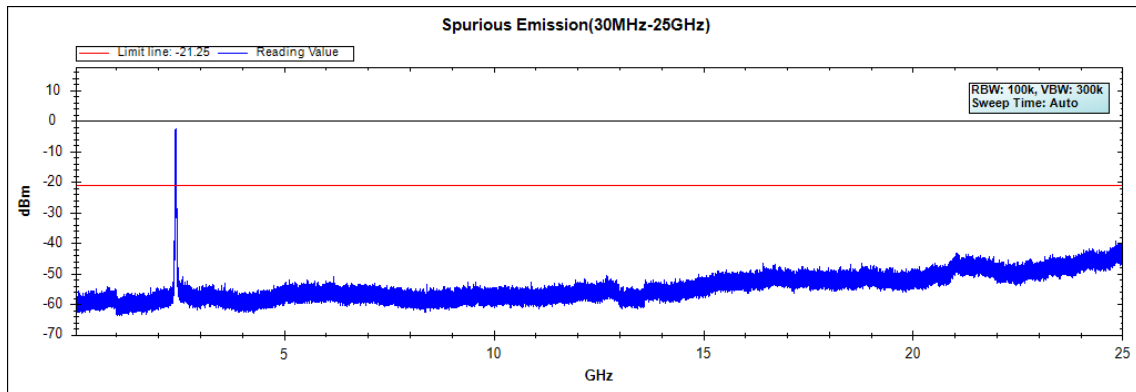

**Channel 06 (2437MHz) 30MHz -25GHz**

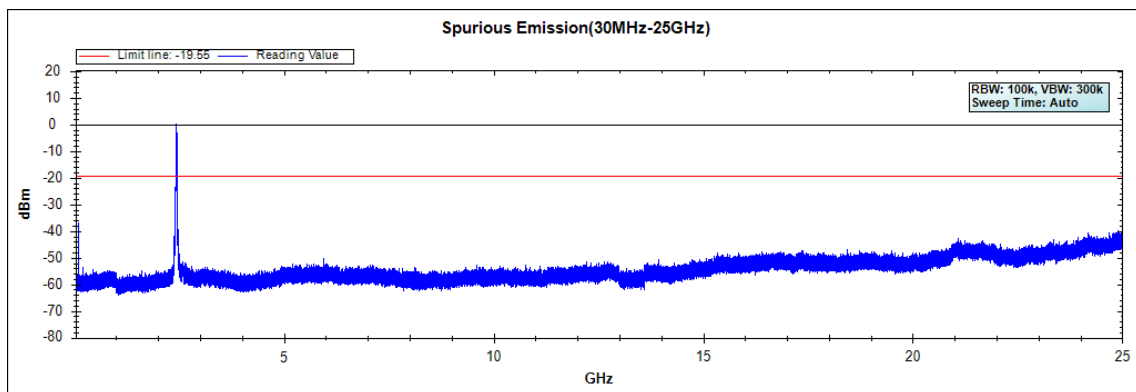

**Channel 09 (2452MHz) 30MHz -25GHz**

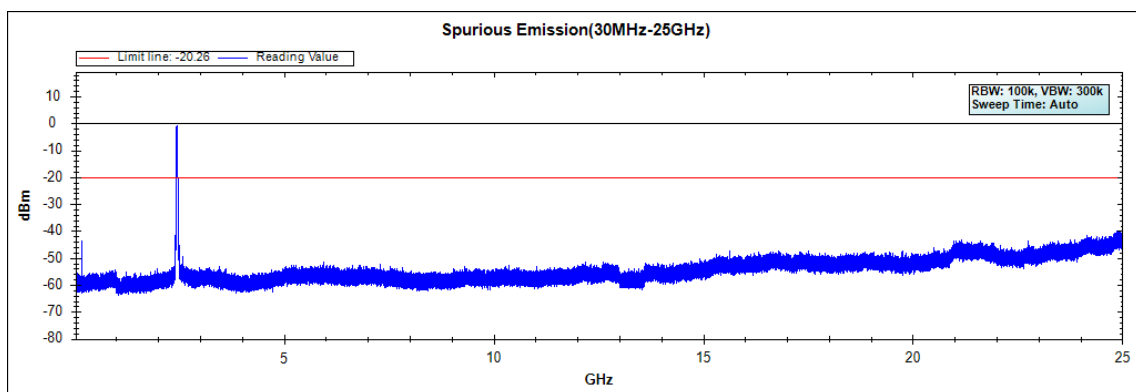



Channel 10 (2457MHz) 30MHz -25GHz

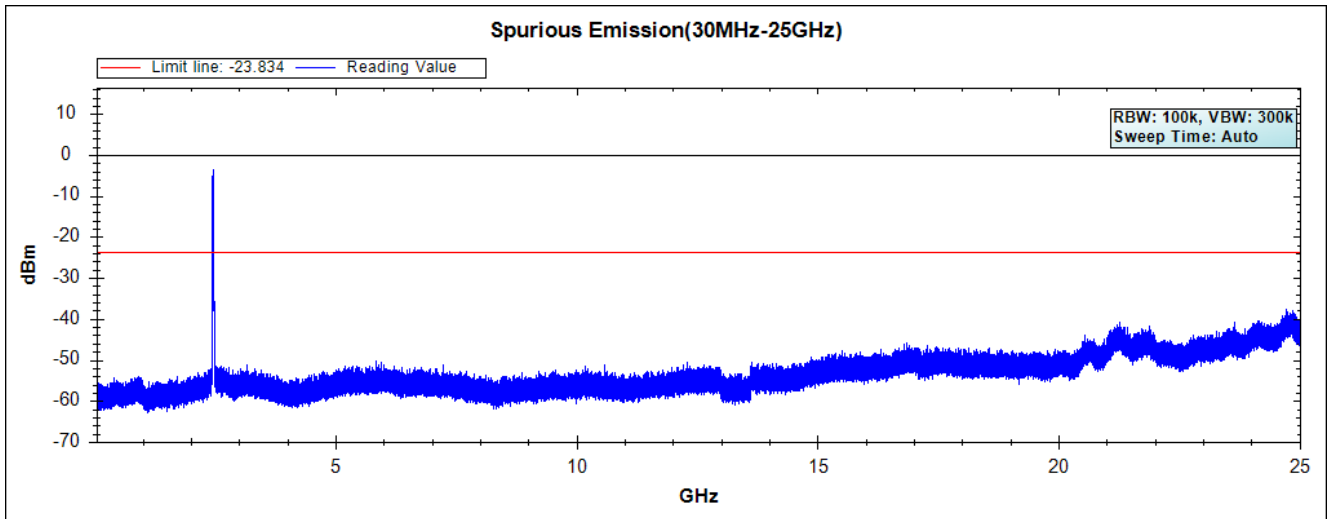

Note: The above test pattern is synthesized by multiple of the frequency range.

Product : Intel® Dual Band Wireless-AC 8260  
Test Item : RF Antenna Conducted Spurious  
Test Site : No.3 OATS  
Test Mode : Mode 4 Beamforming: Transmit - 802.11n-20BW\_14.4Mbps(5G Band)

**Chaia B**

**Channel 49 (5745MHz) 30MHz -40GHz**

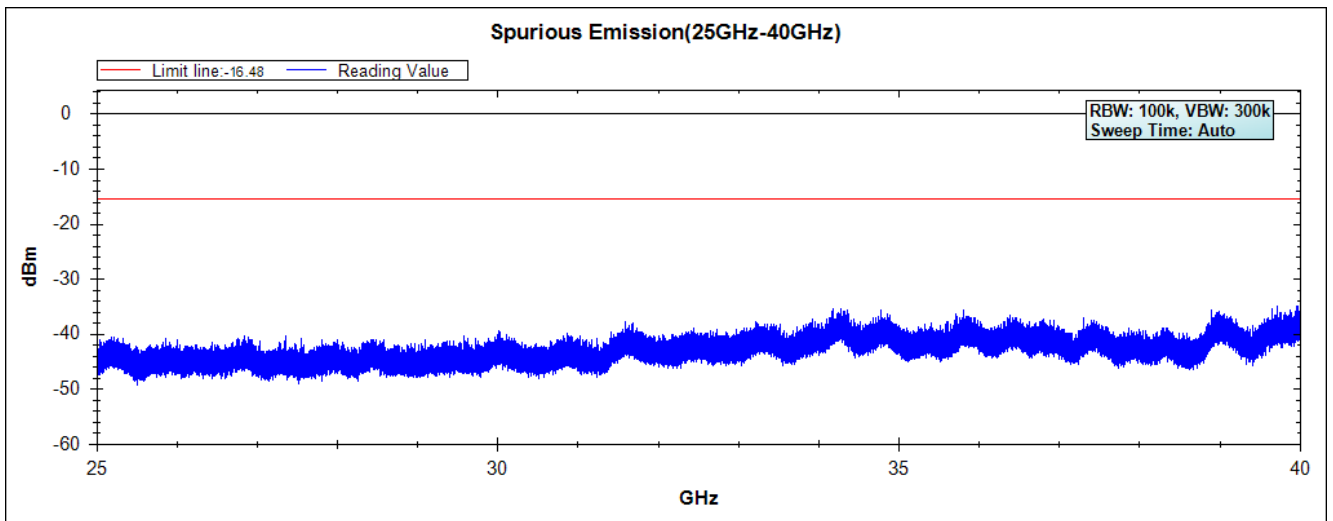
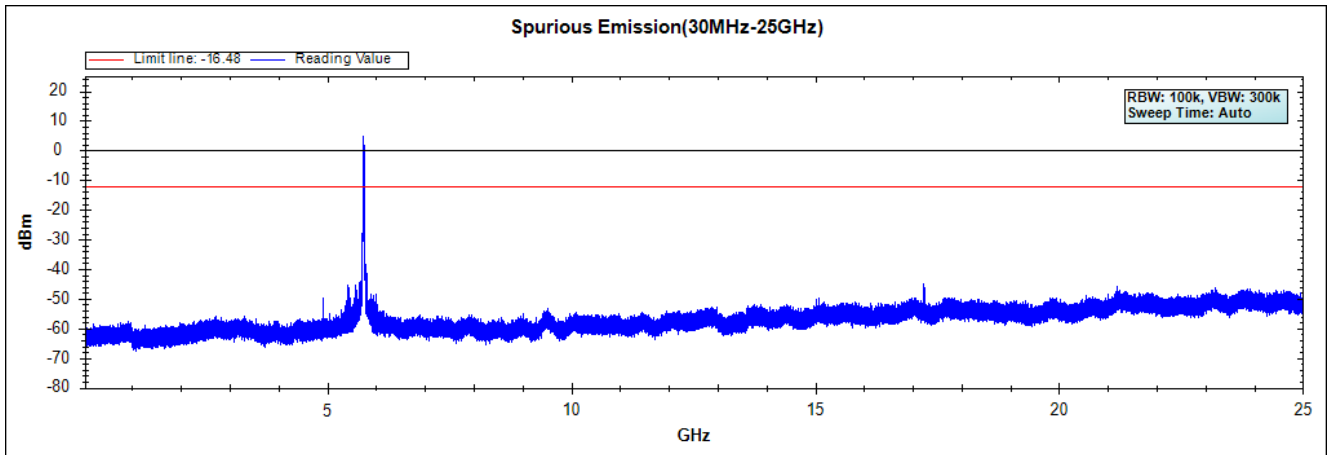

Note: The above test pattern is synthesized by multiple of the frequency range

Channel 157 (5785MHz) 30MHz -40GHz

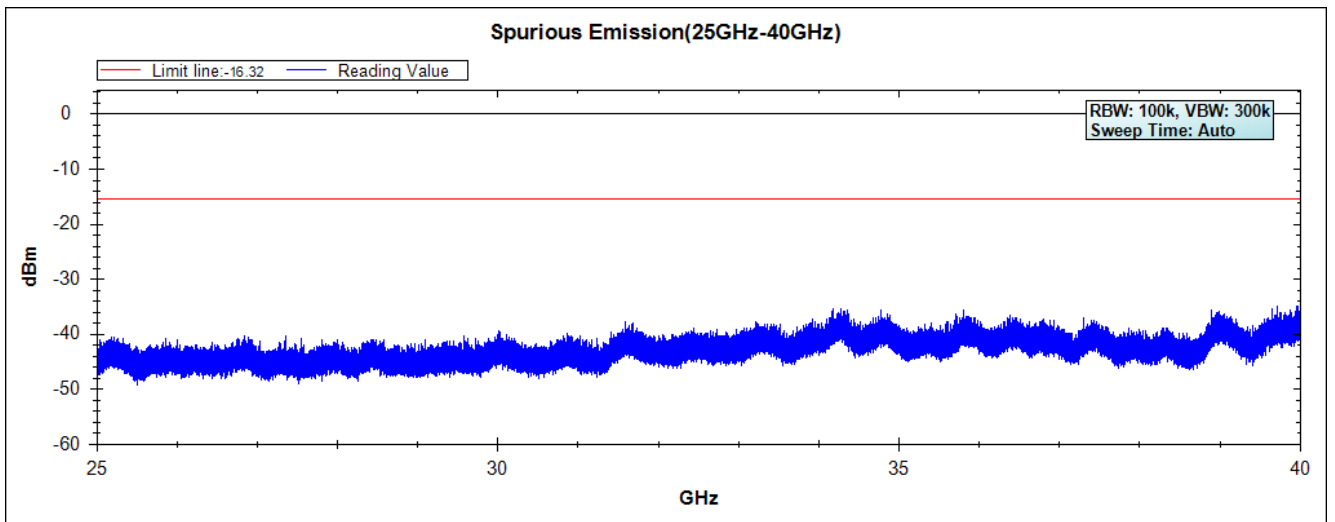
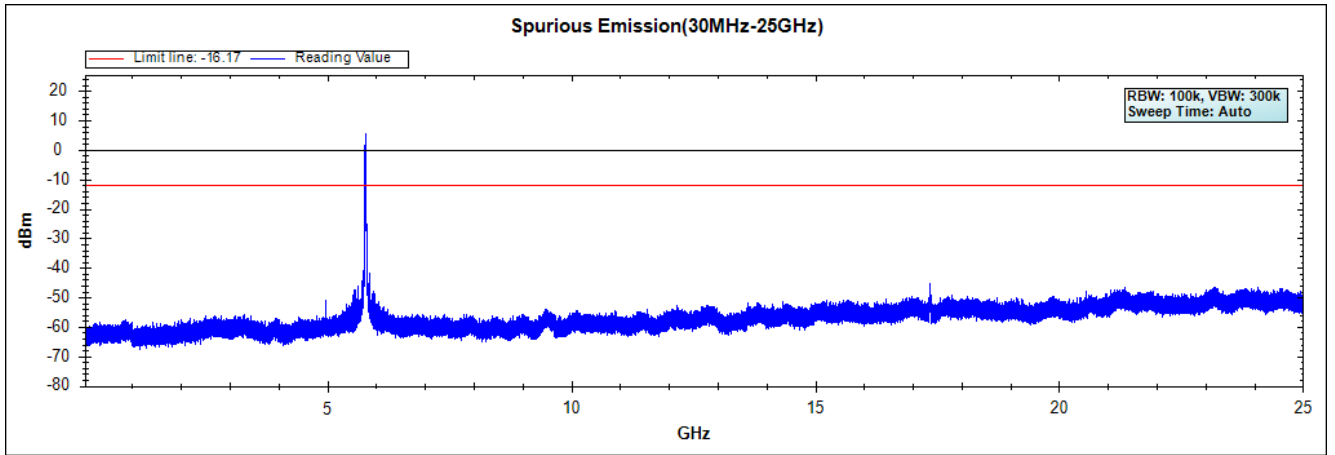

Note: The above test pattern is synthesized by multiple of the frequency range

Channel 165 (5825MHz) 30MHz -40GHz

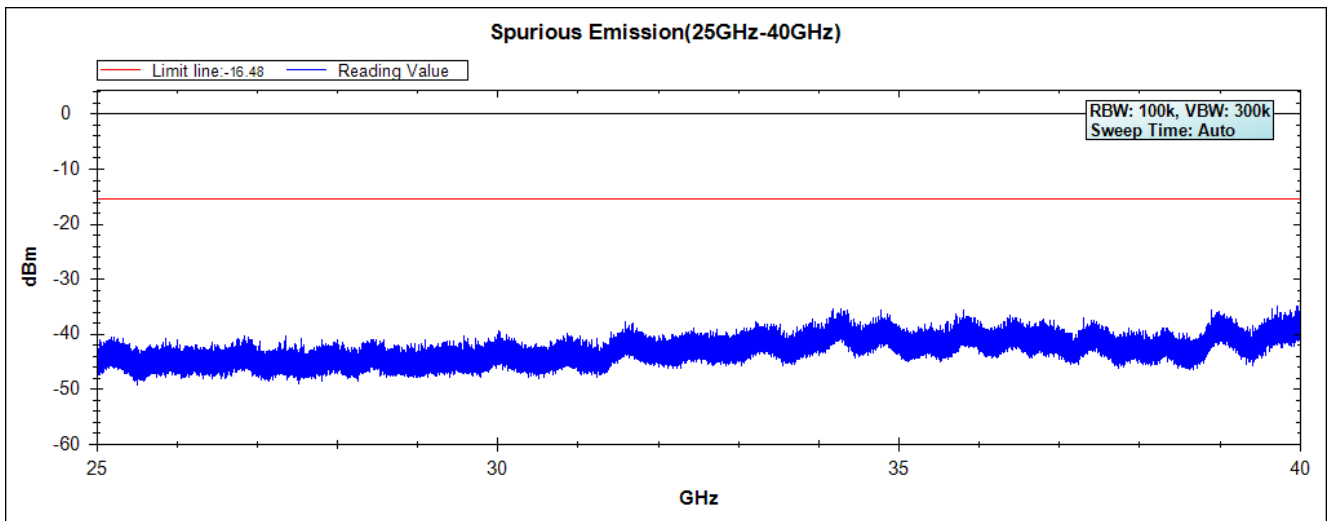
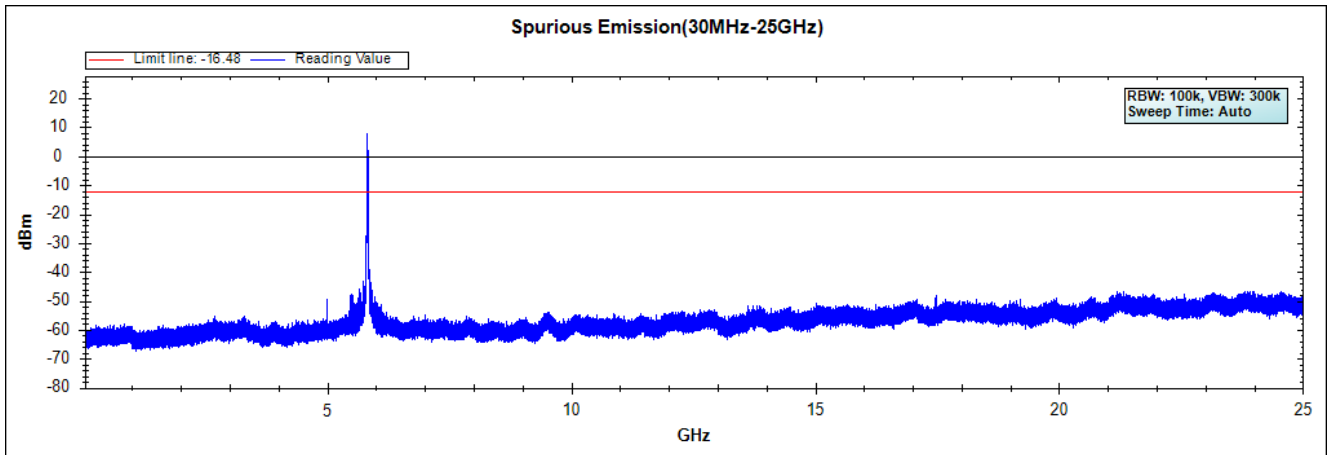

Note: The above test pattern is synthesized by multiple of the frequency range

Product : Intel® Dual Band Wireless-AC 8260  
Test Item : RF Antenna Conducted Spurious  
Test Site : No.3 OATS  
Test Mode : Mode 4 Beamforming: Transmit - 802.11n-40BW\_30Mbps(5G Band)

**Chaia B**

**Channel 151 (5755MHz) 30MHz -40GHz**

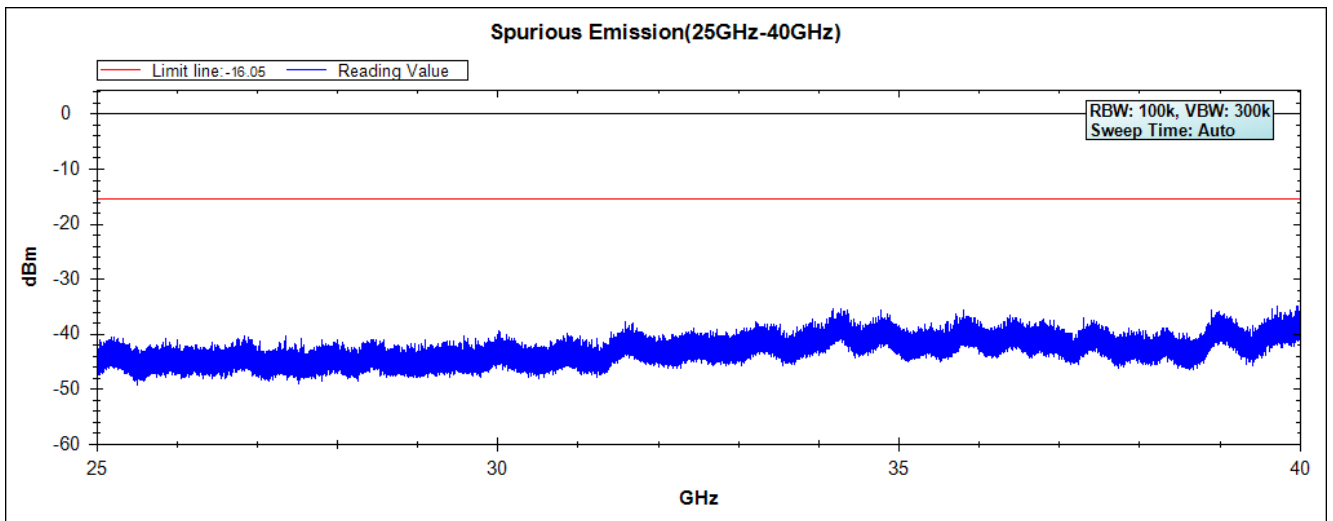
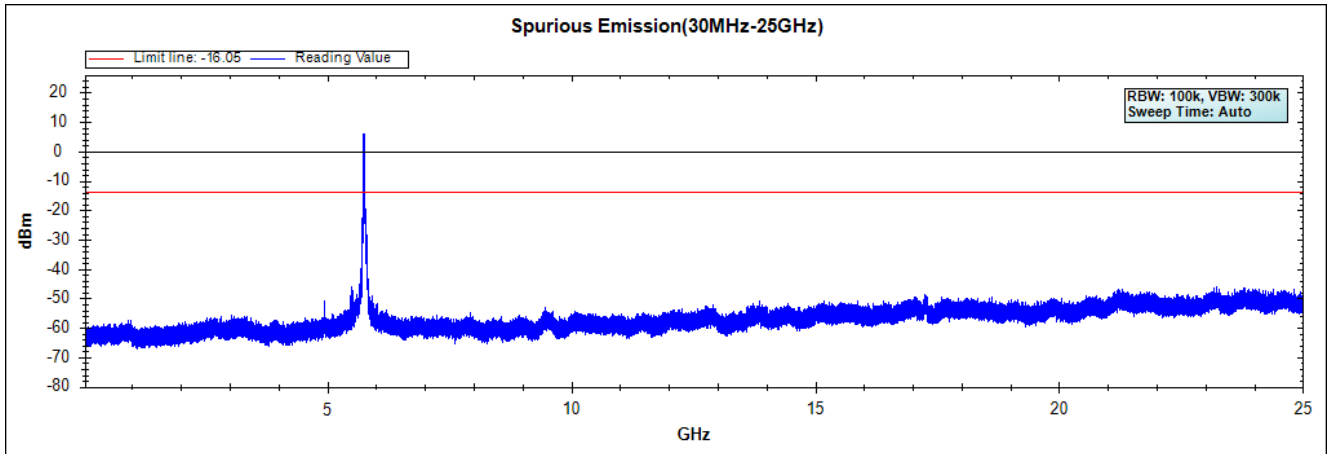

Note: The above test pattern is synthesized by multiple of the frequency range

Channel 159 (5795MHz) 30MHz -40GHz

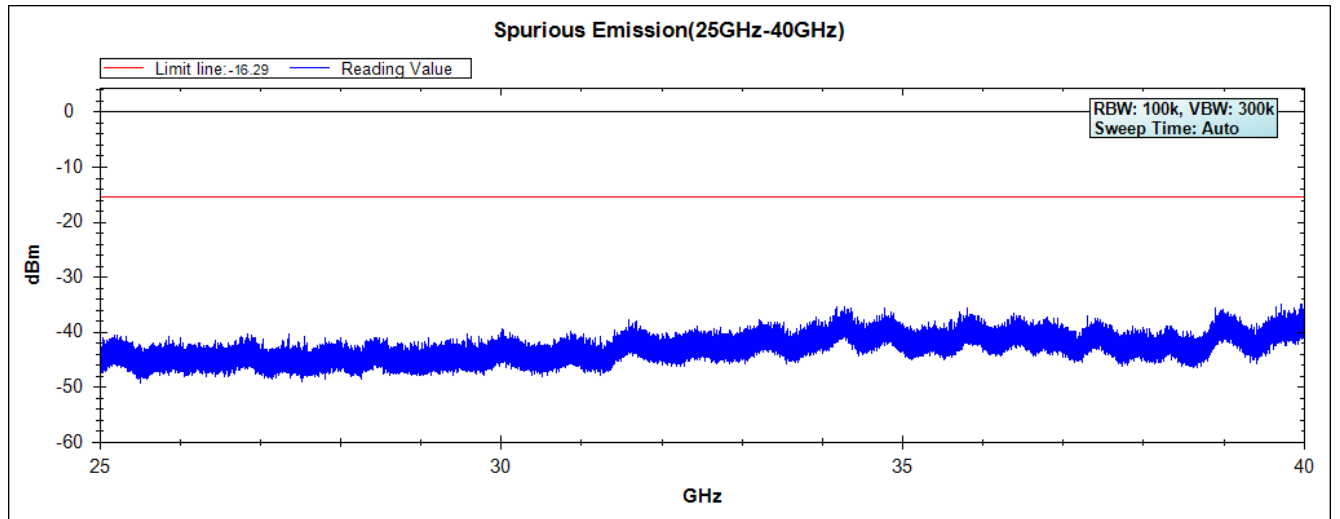
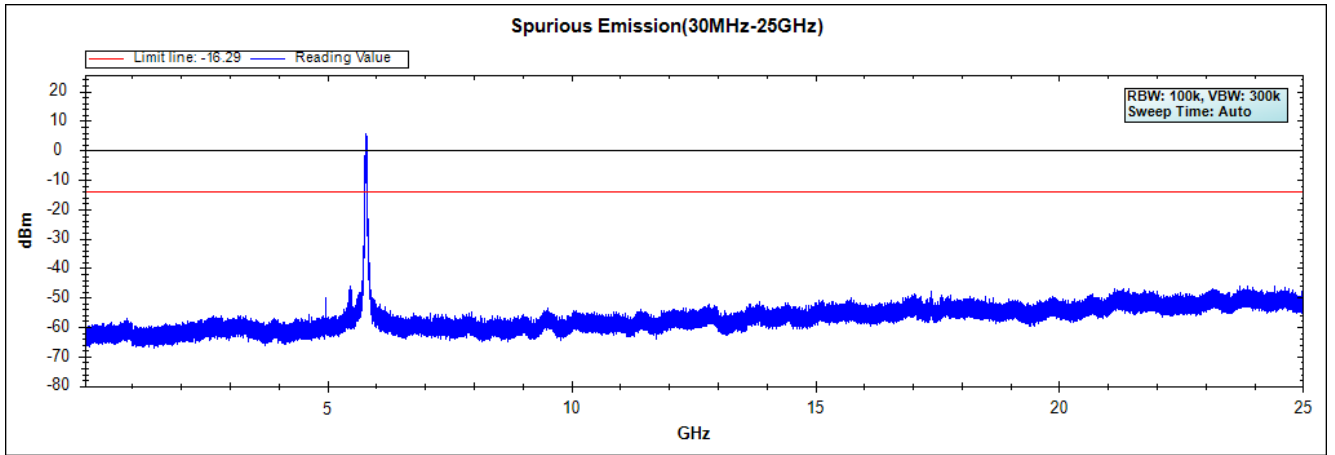

Note: The above test pattern is synthesized by multiple of the frequency range

Product : Intel® Dual Band Wireless-AC 8260  
Test Item : RF Antenna Conducted Spurious  
Test Site : No.3 OATS  
Test Mode : Mode 4 Beamforming: Transmit - 802.11ac-80BW\_65Mbps(5G Band)

**Chaia B**

**Channel 155 (5775MHz) 30MHz -40GHz**

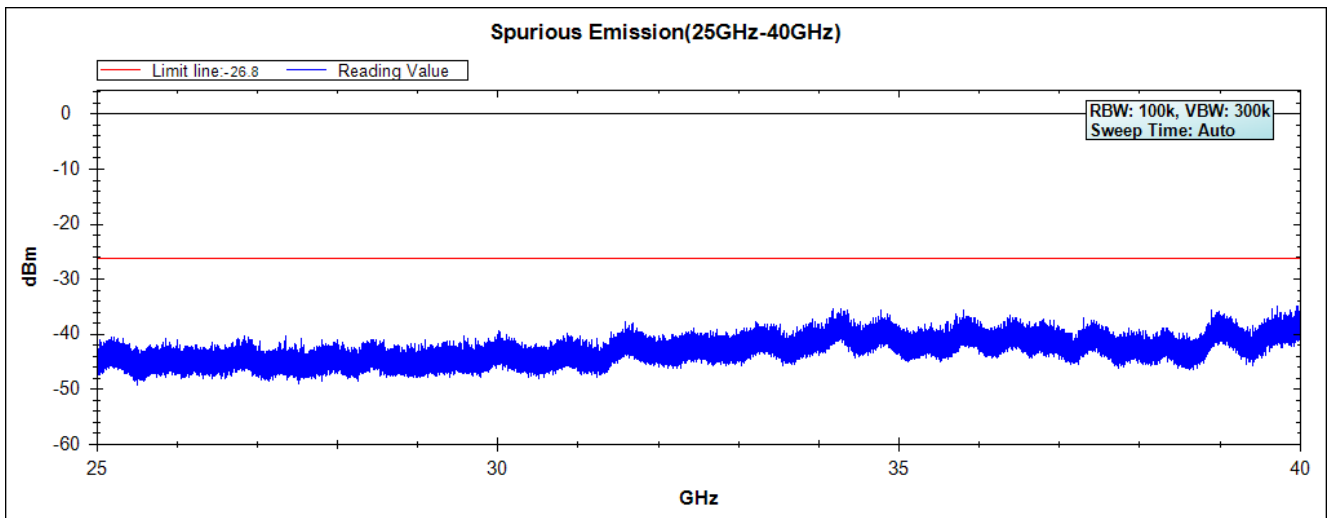
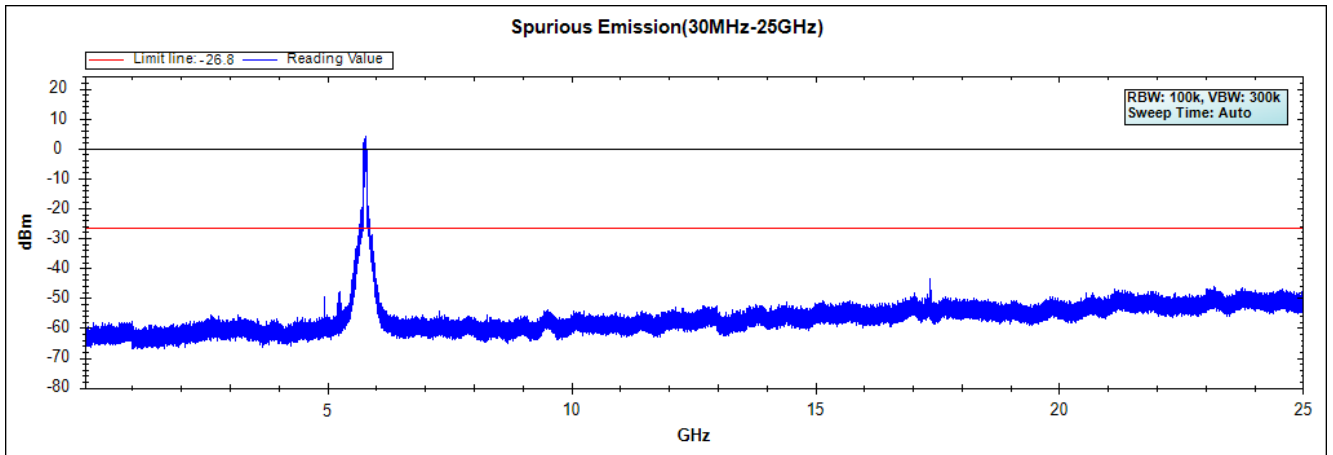

Note: The above test pattern is synthesized by multiple of the frequency range

**6. Band Edge**

**6.1. Test Equipment**

**RF Conducted Measurement**

The following test equipments are used during the band edge tests:

	Equipment	Manufacturer	Model No./Serial No.	Last Cal.
	Spectrum Analyzer	R&S	FSP40 / 100170	Jun, 2014
	Spectrum Analyzer	Agilent	E4407B / US39440758	Jun, 2014
X	Spectrum Analyzer	Agilent	N9010A / MY48030495	Apr., 2015
	8-WAY Power Divider	JFW	50PD-647 / 526770 0916	Apr., 2015

Note:

1. All equipments are calibrated with traceable calibrations. Each calibration is traceable to the national or international standards.
2. The test instruments marked with “X” are used to measure the final test results.

**RF Radiated Measurement:**

The following test equipments are used during the band edge tests:

Test Site		Equipment	Manufacturer	Model No./Serial No.	Last Cal.
☒ CB # 8	X	Spectrum Analyzer	R&S	FSP40/ 100339	Oct, 2014
	X	Horn Antenna	ETS-Lindgren	3117/ 35205	Mar., 2015
	X	Horn Antenna	Schwarzbeck	BBHA9170/209	Jan, 2015
	X	Horn Antenna	TRC	AH-0801/95051	Aug, 2014
	X	Pre-Amplifier	EMCI	EMC012630SE/980210	Jan, 2015
	X	Pre-Amplifier	MITEQ	JS41-001040000-58-5P/153945	Jul, 2014
	X	Pre-Amplifier	NARDA	DBL-1840N506/013	Jul, 2014

- Note:
1. All instruments are calibrated every one year.
  2. The test instruments marked by “X” are used to measure the final test results.



## 6.2. Test Setup

### RF Conducted Measurement

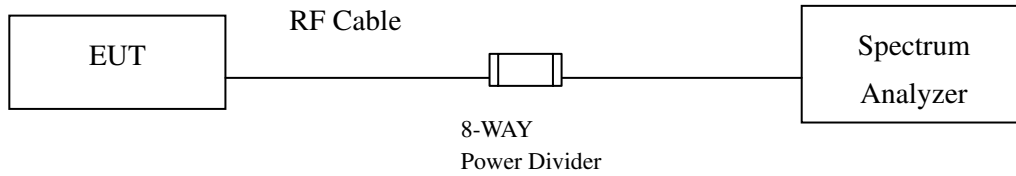

### RF Radiated Measurement:

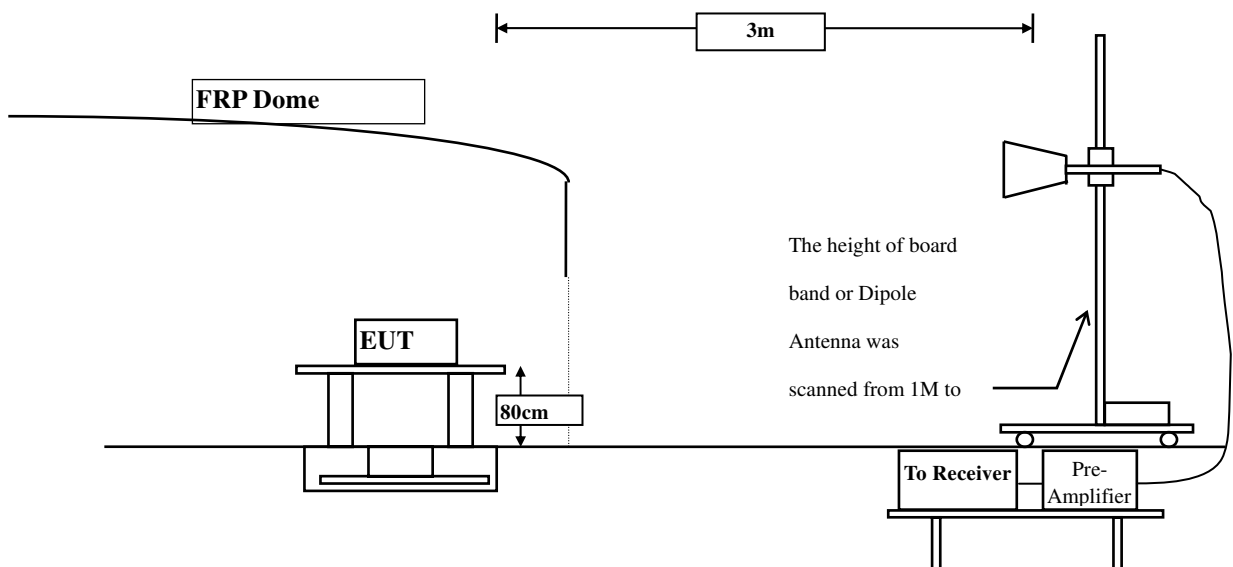

## 6.3. Limits

Emissions radiated outside of the specified frequency bands, except for harmonics, shall be attenuated by at least 20dB below the level of the fundamental or to the general radiated emission limits in paragraph 15.209, whichever is the lesser attenuation.

#### **6.4. Test Procedure**

The EUT was setup according to ANSI C63.10, 2009 and tested according to DTS test procedure of KDB558074 for compliance to FCC 47CFR 15.247 requirements.

The EUT is placed on a turn table which is 0.8 meter above ground. The turn table is rotated 360 degrees to determine the position of the maximum emission level. The EUT was positioned such that the distance from antenna to the EUT was 3 meters.

The antenna is scanned from 1 meter to 4 meters to find out the maximum emission level. This is repeated for both horizontal and vertical polarization of the antenna. In order to find the maximum emission, all of the interface cables were manipulated according to ANSI C63.10:2009 on radiated measurement.

#### **6.5. Uncertainty**

± 3.9 dB above 1GHz

± 3.8 dB below 1GHz

### 6.6. Test Result of Band Edge

Product : Intel® Dual Band Wireless-AC 8260  
 Test Item : Band Edge  
 Test Site : No.3 OATS  
 Test Mode : Mode 1 SISO A: Transmit (802.11b 1Mbps)

#### RF Radiated Measurement (Horizontal):

Channel No.	Frequency (MHz)	Correct Factor (dB)	Reading Level (dBuV)	Emission Level (dBuV/m)	Peak Limit (dBuV/m)	Average Limit (dBuV/m)	Result
01 (Peak)	2390.000	31.509	37.784	69.293	74.00	54.00	Pass
01 (Peak)	2400.000	31.561	47.077	78.638	74.00	54.00	Pass
01 (Peak)	2413.800	31.651	76.969	108.621	--	--	Pass
01 (Average)	2387.000	31.497	21.802	53.299	74.00	54.00	Pass
01 (Average)	2390.000	31.509	16.099	47.608	74.00	54.00	Pass
01 (Average)	2400.000	31.561	25.539	57.100	74.00	54.00	Pass
01 (Average)	2412.800	31.645	71.444	103.088	--	--	Pass

**Figure Channel 01: Horizontal (Peak)**

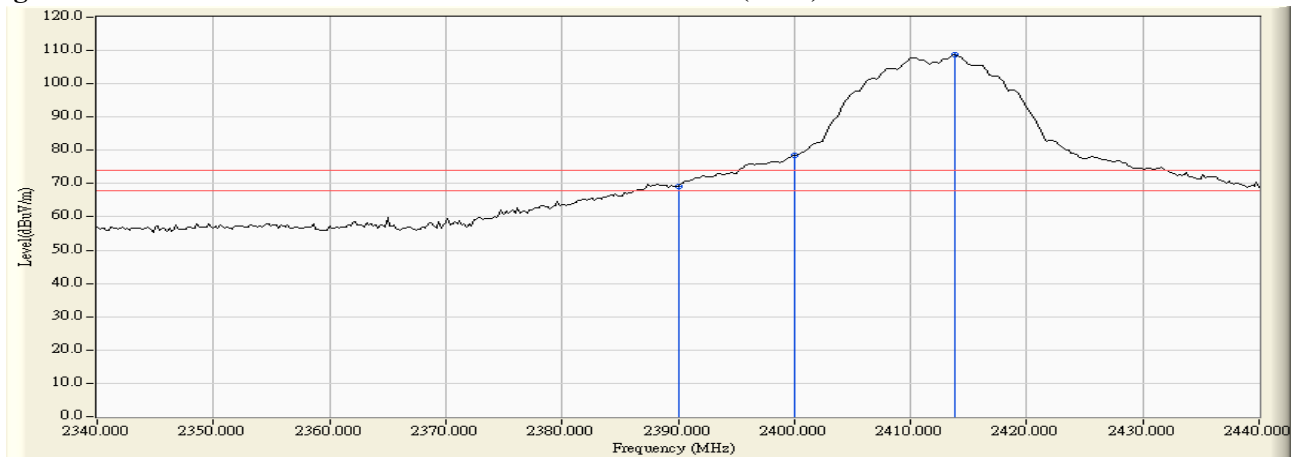

**Figure Channel 01: Horizontal (Average)**

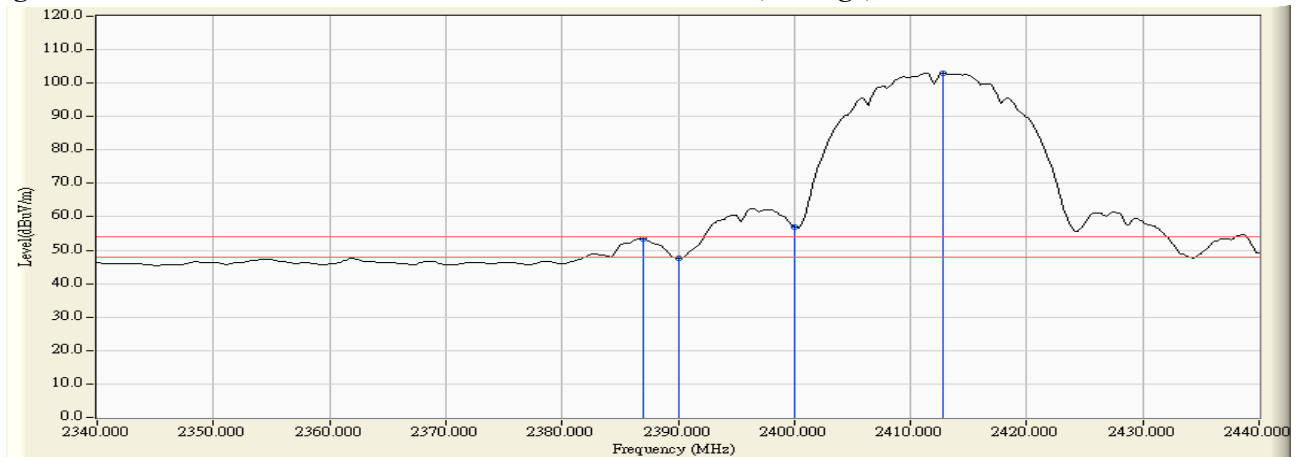

Note:

1. All readings above 1GHz are performed with peak and/or average measurements as necessary.
2. Peak measurements: RBW = 1MHz, VBW = 3 MHz, Sweep: Auto.
3. Average measurements: RBW = 1MHz, VBW = 10 Hz, Sweep: Auto.
4. “ \* ”, means this data is the worst emission level.
5. Measurement Level = Reading Level + Correct Factor.
6. The average measurement was not performed when the peak measured data under the limit of average detection.

Product : Intel® Dual Band Wireless-AC 8260  
 Test Item : Band Edge  
 Test Site : No.3 OATS  
 Test Mode : Mode 1 SISO A: Transmit (802.11b 1Mbps)

**RF Radiated Measurement (Vertical):**

Channel No.	Frequency (MHz)	Correct Factor (dB)	Reading Level (dBuV)	Emission Level (dBuV/m)	Peak Limit (dBuV/m)	Average Limit (dBuV/m)	Result
01 (Peak)	2388.200	30.924	36.361	67.285	74.00	54.00	Pass
01 (Peak)	2390.000	30.915	36.100	67.015	74.00	54.00	Pass
01 (Peak)	2400.000	30.912	44.754	75.666	74.00	54.00	Pass
01 (Peak)	2413.800	30.961	74.555	105.516	--	--	Pass
01 (Average)	2386.400	30.932	19.379	50.311	74.00	54.00	Pass
01 (Average)	2390.000	30.915	14.257	45.172	74.00	54.00	Pass
01 (Average)	2400.000	30.912	23.353	54.265	74.00	54.00	Pass
01 (Average)	2412.800	30.955	69.029	99.984	--	--	Pass

**Figure Channel 01:**

**Vertical (Peak)**

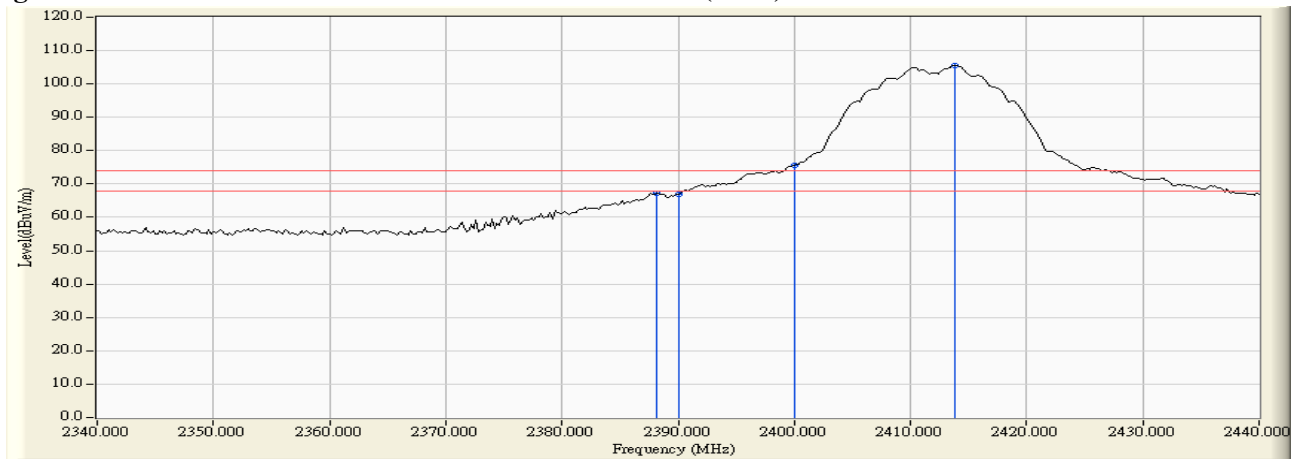

**Figure Channel 01:**

**Vertical (Average)**

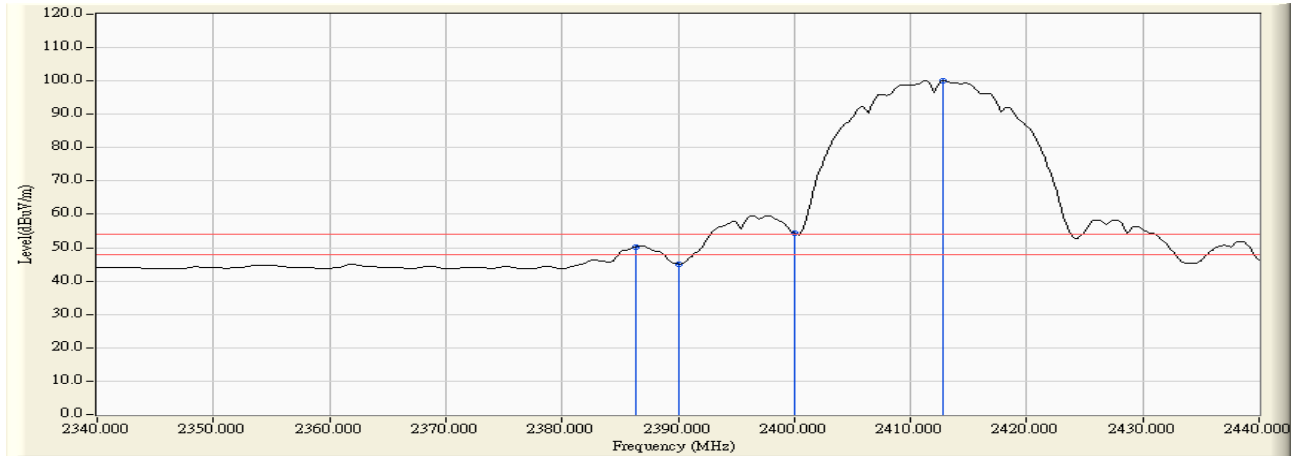

Note:

1. All readings above 1GHz are performed with peak and/or average measurements as necessary.
2. Peak measurements: RBW = 1MHz, VBW = 3 MHz, Sweep: Auto.
3. Average measurements: RBW = 1MHz, VBW = 10 Hz, Sweep: Auto.
4. “ \* ”, means this data is the worst emission level.
5. Measurement Level = Reading Level + Correct Factor.
6. The average measurement was not performed when the peak measured data under the limit of average detection.

Product : Intel® Dual Band Wireless-AC 8260  
 Test Item : Band Edge  
 Test Site : No.3 OATS  
 Test Mode : Mode 1 SISO A: Transmit (802.11b 1Mbps)

**RF Radiated Measurement (Horizontal):**

Channel No.	Frequency (MHz)	Correct Factor (dB)	Reading Level (dBuV)	Emission Level (dBuV/m)	Peak Limit (dBuV/m)	Average Limit (dBuV/m)	Result
02 (Peak)	2390.000	31.509	35.526	67.035	74.00	54.00	Pass
02 (Peak)	2400.000	31.561	42.700	74.261	74.00	54.00	Pass
02 (Peak)	2418.800	31.690	77.681	109.371	--	--	Pass
02 (Average)	2390.000	31.509	21.608	53.117	74.00	54.00	Pass
02 (Average)	2400.000	31.561	29.733	61.294	74.00	54.00	Pass
02 (Average)	2416.400	31.672	72.514	104.186	--	--	Pass

**Figure Channel 02:**

**Horizontal (Peak)**

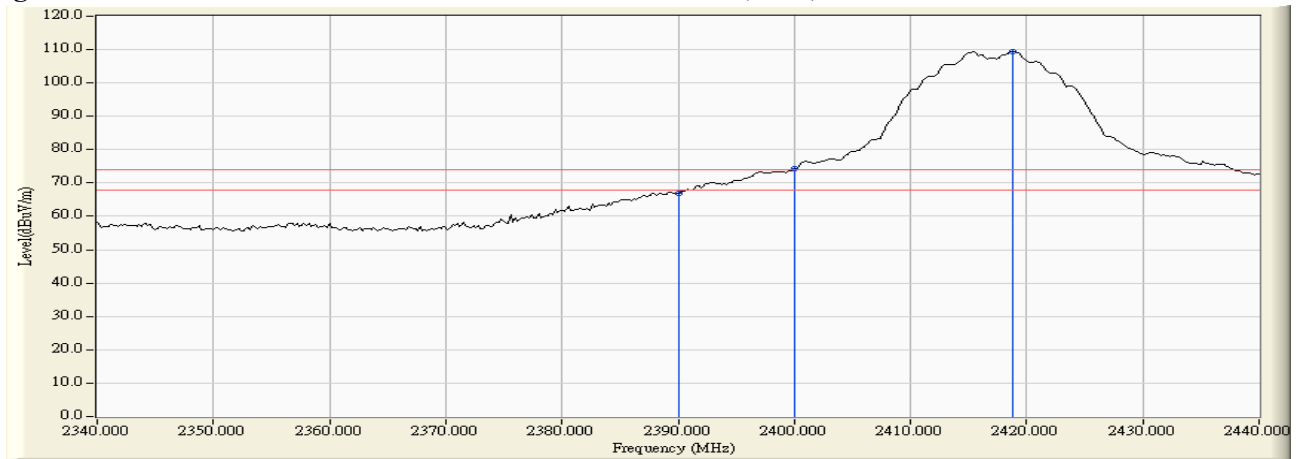

**Figure Channel 02:**

**Horizontal (Average)**

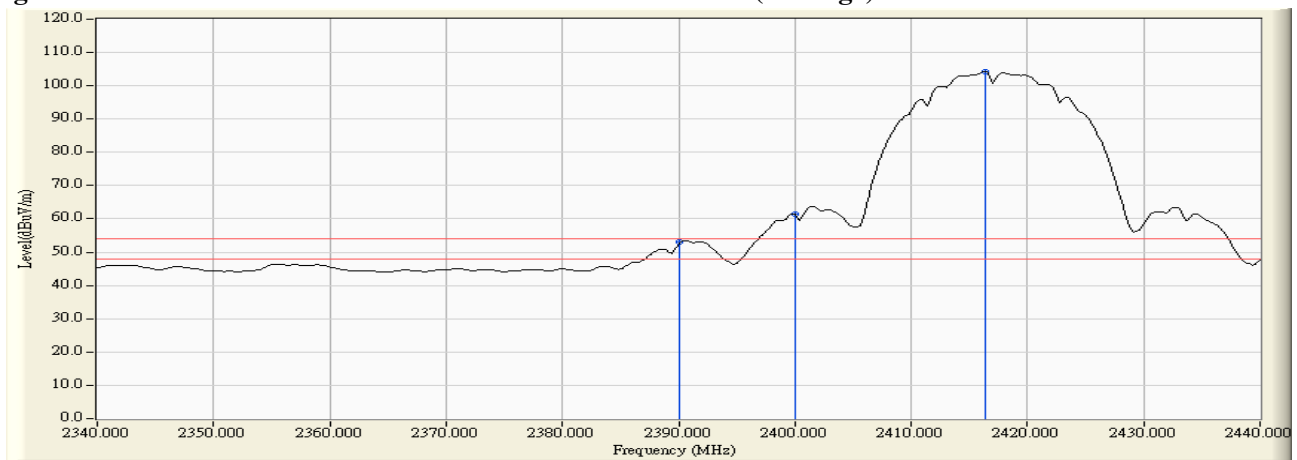

Note:

1. All readings above 1GHz are performed with peak and/or average measurements as necessary.
2. Peak measurements: RBW = 1MHz, VBW = 3 MHz, Sweep: Auto.
3. Average measurements: RBW = 1MHz, VBW = 10 Hz, Sweep: Auto.
4. “ \* ”, means this data is the worst emission level.
5. Measurement Level = Reading Level + Correct Factor.
6. The average measurement was not performed when the peak measured data under the limit of average detection.



Product : Intel® Dual Band Wireless-AC 8260  
 Test Item : Band Edge  
 Test Site : No.3 OATS  
 Test Mode : Mode 1 SISO A: Transmit (802.11b 1Mbps)

**RF Radiated Measurement (Vertical):**

Channel No.	Frequency (MHz)	Correct Factor (dB)	Reading Level (dBuV)	Emission Level (dBuV/m)	Peak Limit (dBuV/m)	Average Limit (dBuV/m)	Result
02 (Peak)	2388.200	30.924	33.913	64.837	74.00	54.00	Pass
02 (Peak)	2390.000	30.915	32.817	63.732	74.00	54.00	Pass
02 (Peak)	2400.000	30.912	40.175	71.087	74.00	54.00	Pass
02 (Peak)	2418.800	30.995	74.601	105.596	--	--	Pass
02 (Average)	2390.000	30.915	19.001	49.916	74.00	54.00	Pass
02 (Average)	2400.000	30.912	27.333	58.245	74.00	54.00	Pass
02 (Average)	2416.400	30.979	69.440	100.419	--	--	Pass

**Figure Channel 02: Vertical (Peak)**

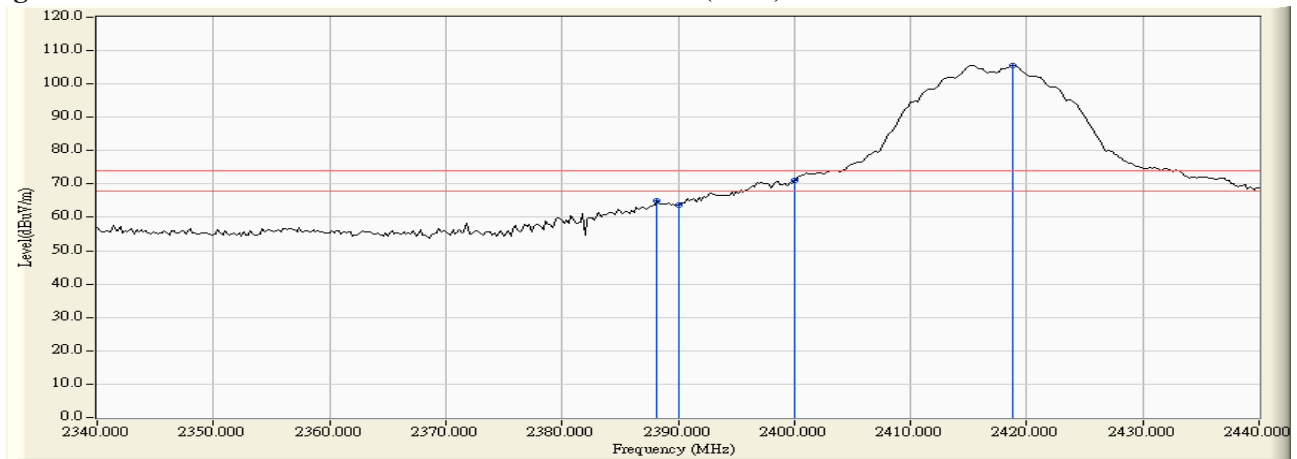

**Figure Channel 02: Vertical (Average)**

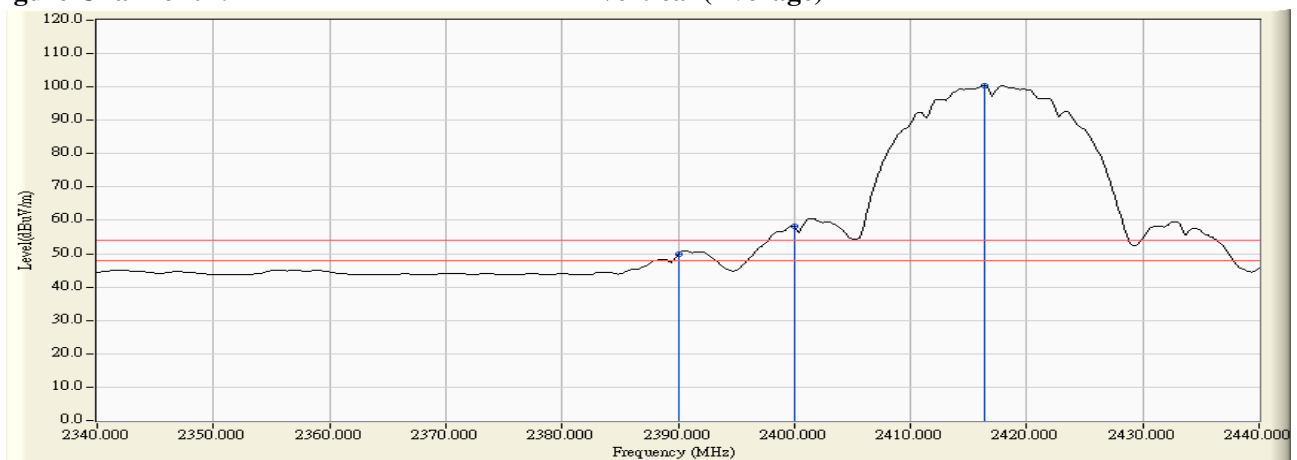

Note:

1. All readings above 1GHz are performed with peak and/or average measurements as necessary.
2. Peak measurements: RBW = 1MHz, VBW = 3 MHz, Sweep: Auto.
3. Average measurements: RBW = 1MHz, VBW = 10 Hz, Sweep: Auto.
4. “ \* ”, means this data is the worst emission level.
5. Measurement Level = Reading Level + Correct Factor.
6. The average measurement was not performed when the peak measured data under the limit of average detection.

Product : Intel® Dual Band Wireless-AC 8260  
 Test Item : Band Edge  
 Test Site : No.3 OATS  
 Test Mode : Mode 1 SISO A: Transmit (802.11b 1Mbps)

**RF Radiated Measurement (Horizontal):**

Channel No.	Frequency (MHz)	Correct Factor (dB)	Reading Level (dBuV)	Emission Level (dBuV/m)	Peak Limit (dBuV/m)	Average Limit (dBuV/m)	Result
03 (Peak)	2390.000	31.509	35.273	66.782	74.00	54.00	Pass
03 (Peak)	2400.000	31.561	40.403	71.964	74.00	54.00	Pass
03 (Peak)	2423.800	31.729	79.647	111.376	--	--	Pass
03 (Average)	2385.600	31.492	19.875	51.367	74.00	54.00	Pass
03 (Average)	2390.000	31.509	20.358	51.867	74.00	54.00	Pass
03 (Average)	2422.800	31.721	73.936	105.657	--	--	Pass

**Figure Channel 03: Horizontal (Peak)**

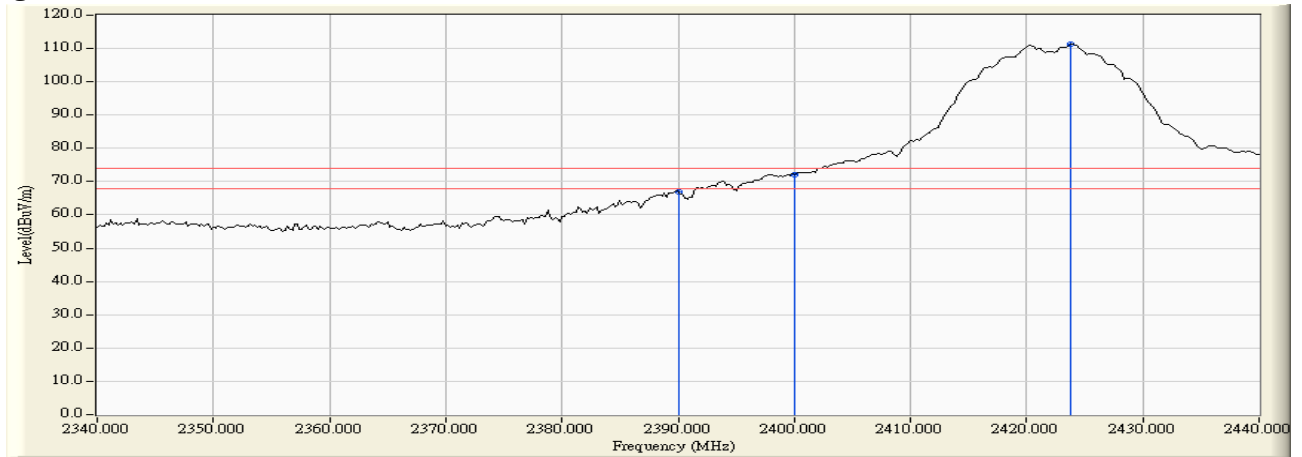

**Figure Channel 03: Horizontal (Average)**

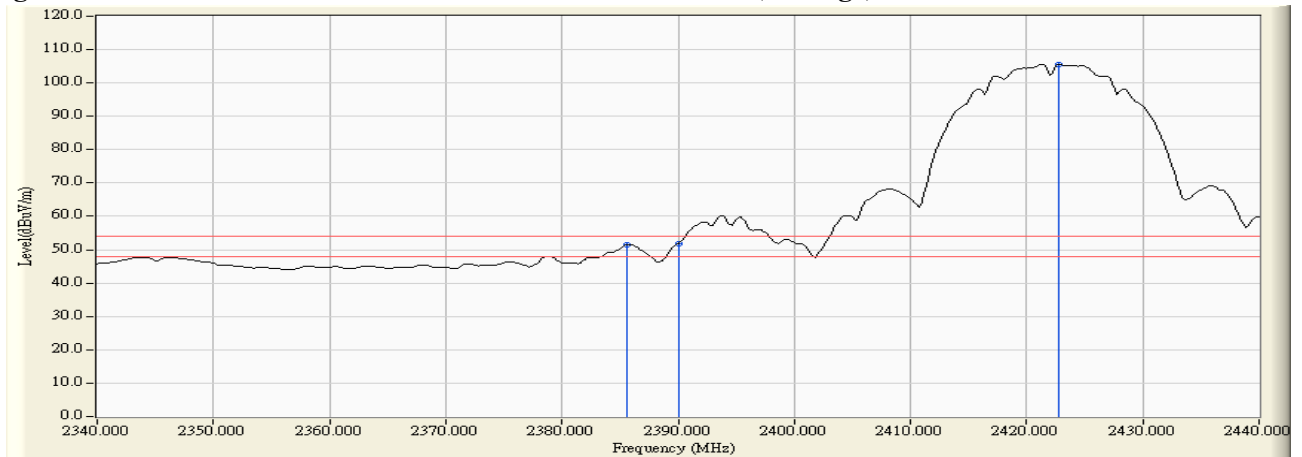

Note:

1. All readings above 1GHz are performed with peak and/or average measurements as necessary.
2. Peak measurements: RBW = 1MHz, VBW = 3 MHz, Sweep: Auto.
3. Average measurements: RBW = 1MHz, VBW = 10 Hz, Sweep: Auto.
4. “ \* ”, means this data is the worst emission level.
5. Measurement Level = Reading Level + Correct Factor.
6. The average measurement was not performed when the peak measured data under the limit of average detection.

Product : Intel® Dual Band Wireless-AC 8260  
 Test Item : Band Edge  
 Test Site : No.3 OATS  
 Test Mode : Mode 1 SISO A: Transmit (802.11b 1Mbps)

**RF Radiated Measurement (Vertical):**

Channel No.	Frequency (MHz)	Correct Factor (dB)	Reading Level (dBuV)	Emission Level (dBuV/m)	Peak Limit (dBuV/m)	Average Limit (dBuV/m)	Result
03 (Peak)	2390.000	30.915	33.411	64.326	74.00	54.00	Pass
03 (Peak)	2400.000	30.912	39.183	70.095	74.00	54.00	Pass
03 (Peak)	2423.800	31.029	77.066	108.095	--	--	Pass
03 (Average)	2385.400	30.937	20.900	51.837	74.00	54.00	Pass
03 (Average)	2390.000	30.915	20.253	51.168	74.00	54.00	Pass
03 (Average)	2400.000	30.912	18.822	49.734	74.00	54.00	Pass
03 (Average)	2422.800	31.023	71.557	102.580	--	--	Pass

**Figure Channel 03: Vertical (Peak)**

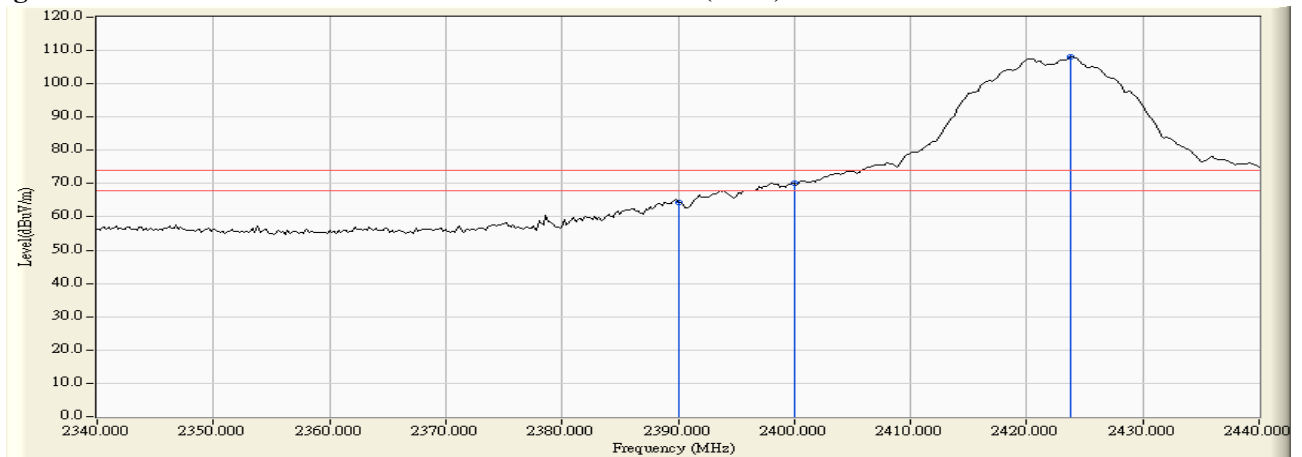

**Figure Channel 03: Vertical (Average)**

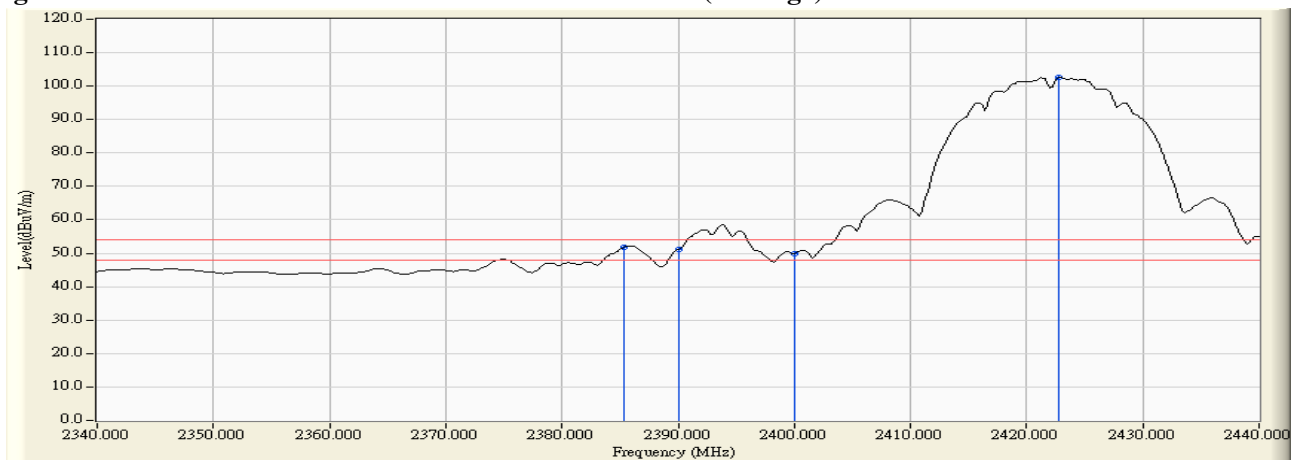

Note:

1. All readings above 1GHz are performed with peak and/or average measurements as necessary.
2. Peak measurements: RBW = 1MHz, VBW = 3 MHz, Sweep: Auto.
3. Average measurements: RBW = 1MHz, VBW = 10 Hz, Sweep: Auto.
4. “ \* ”, means this data is the worst emission level.
5. Measurement Level = Reading Level + Correct Factor.
6. The average measurement was not performed when the peak measured data under the limit of average detection.

Product : Intel® Dual Band Wireless-AC 8260  
 Test Item : Band Edge  
 Test Site : No.3 OATS  
 Test Mode : Mode 1 SISO A: Transmit (802.11b 1Mbps)

**RF Radiated Measurement (Horizontal):**

Channel No.	Frequency (MHz)	Correct Factor (dB)	Reading Level (dBuV)	Emission Level (dBuV/m)	Peak Limit (dBuV/m)	Average Limit (dBuV/m)	Result
09 (Peak)	2453.700	31.957	78.367	110.324	--	--	Pass
09 (Peak)	2483.500	32.182	35.629	67.811	74.00	54.00	Pass
09 (Average)	2451.100	31.937	73.716	105.653	--	--	Pass
09 (Average)	2483.500	32.182	20.489	52.671	74.00	54.00	Pass
09 (Average)	2488.900	32.223	20.797	53.020	74.00	54.00	Pass

**Figure Channel 09: Horizontal (Peak)**

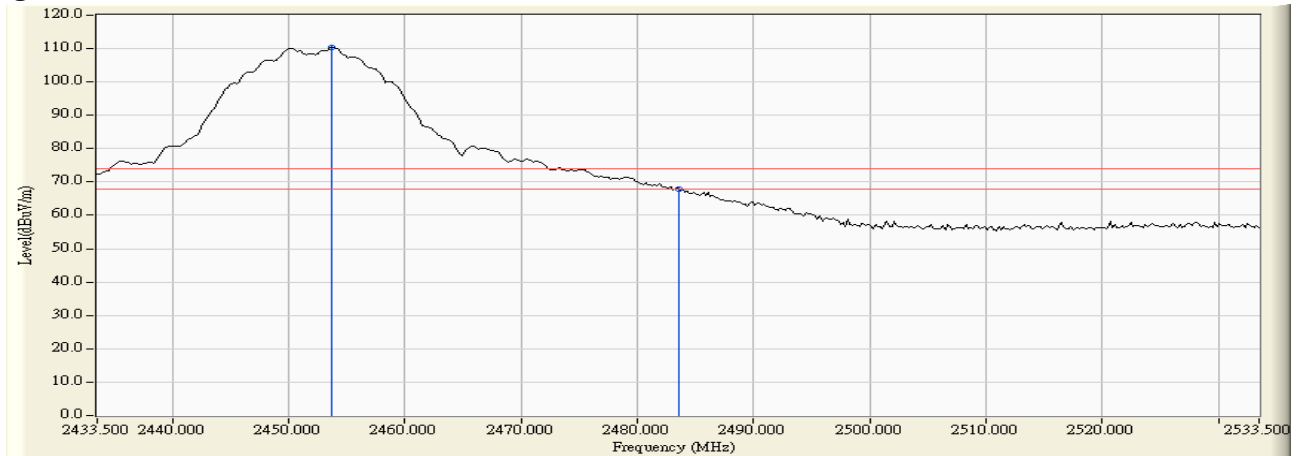

**Figure Channel 09: Horizontal (Average)**

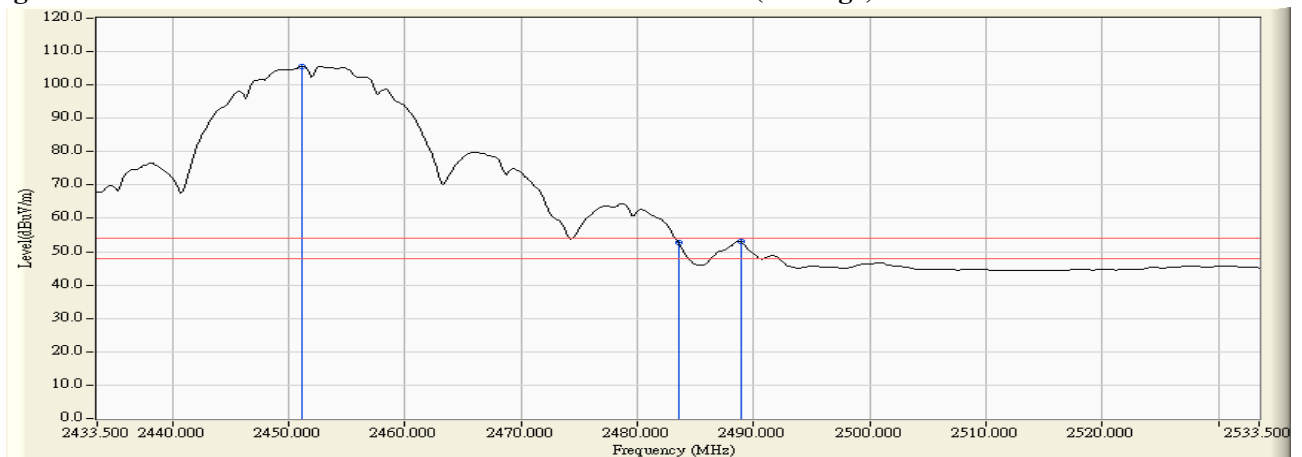

Note:

1. All readings above 1GHz are performed with peak and/or average measurements as necessary.
2. Peak measurements: RBW = 1MHz, VBW = 3 MHz, Sweep: Auto.
3. Average measurements: RBW = 1MHz, VBW = 10 Hz, Sweep: Auto.
4. “ \* ”, means this data is the worst emission level.
5. Measurement Level = Reading Level + Correct Factor.
6. The average measurement was not performed when the peak measured data under the limit of average detection.



Product : Intel® Dual Band Wireless-AC 8260  
 Test Item : Band Edge  
 Test Site : No.3 OATS  
 Test Mode : Mode 1 SISO A: Transmit (802.11b 1Mbps)

**RF Radiated Measurement (Vertical):**

Channel No.	Frequency (MHz)	Correct Factor (dB)	Reading Level (dBuV)	Emission Level (dBuV/m)	Peak Limit (dBuV/m)	Average Limit (dBuV/m)	Result
09 (Peak)	2453.700	31.234	78.327	109.560	--	--	Pass
09 (Peak)	2483.500	31.435	37.944	69.379	74.00	54.00	Pass
09 (Average)	2451.300	31.217	72.718	103.935	--	--	Pass
09 (Average)	2483.500	31.435	20.338	51.773	74.00	54.00	Pass
09 (Average)	2488.900	31.472	20.871	52.343	74.00	54.00	Pass

**Figure Channel 09: Vertical (Peak)**

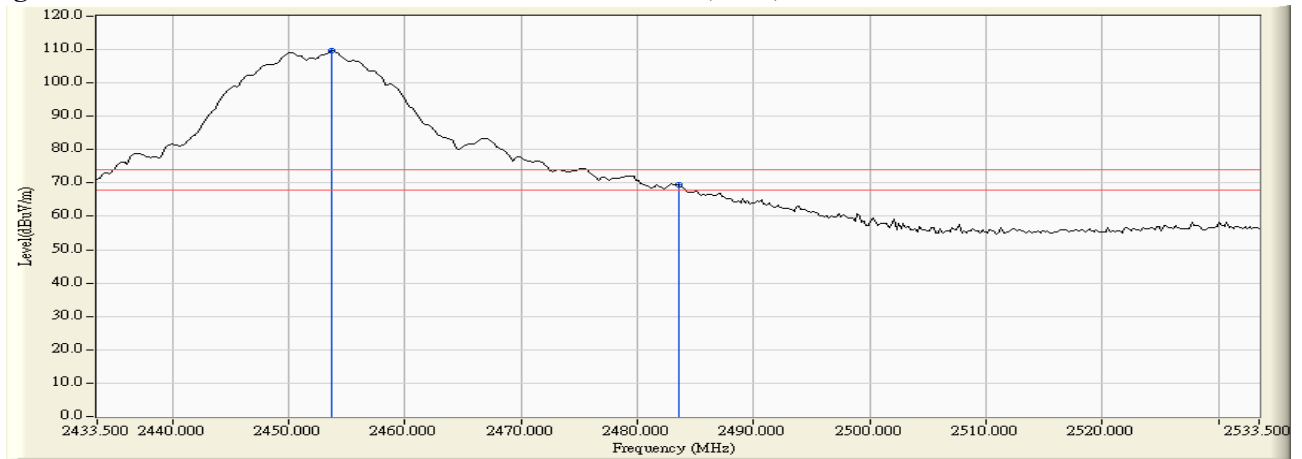

**Figure Channel 09: Vertical (Average)**

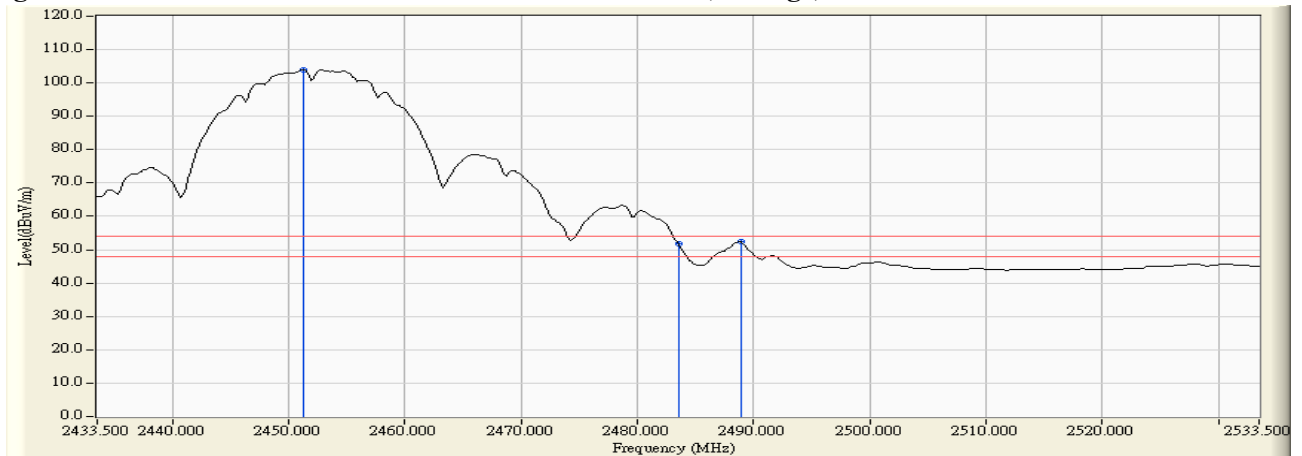

Note:

1. All readings above 1GHz are performed with peak and/or average measurements as necessary.
2. Peak measurements: RBW = 1MHz, VBW = 3 MHz, Sweep: Auto.
3. Average measurements: RBW = 1MHz, VBW = 10 Hz, Sweep: Auto.
4. “ \* ”, means this data is the worst emission level.
5. Measurement Level = Reading Level + Correct Factor.
6. The average measurement was not performed when the peak measured data under the limit of average detection.

Product : Intel® Dual Band Wireless-AC 8260  
 Test Item : Band Edge  
 Test Site : No.3 OATS  
 Test Mode : Mode 1 SISO A: Transmit (802.11b 1Mbps)

**RF Radiated Measurement (Horizontal):**

Channel No.	Frequency (MHz)	Correct Factor (dB)	Reading Level (dBuV)	Emission Level (dBuV/m)	Peak Limit (dBuV/m)	Average Limit (dBuV/m)	Result
10 (Peak)	2458.700	31.994	78.434	110.428	--	--	Pass
10 (Peak)	2483.500	32.182	39.024	71.206	74.00	54.00	Pass
10 (Average)	2456.300	31.976	72.024	104.000	--	--	Pass
10 (Average)	2483.500	32.182	21.476	53.658	74.00	54.00	Pass

**Figure Channel 10: Horizontal (Peak)**

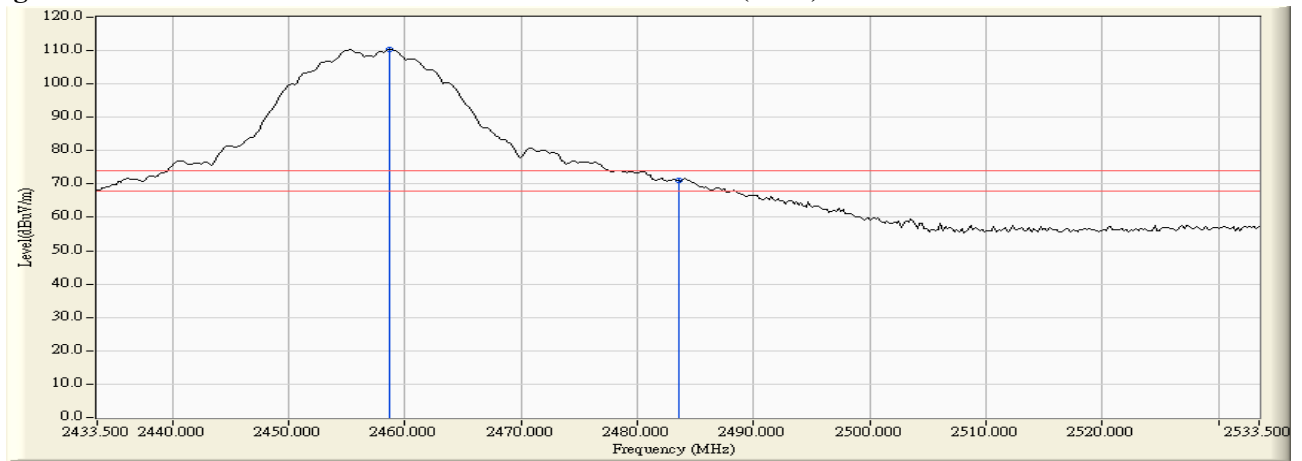

**Figure Channel 10: Horizontal (Average)**



Note:

1. All readings above 1GHz are performed with peak and/or average measurements as necessary.
2. Peak measurements: RBW = 1MHz, VBW = 3 MHz, Sweep: Auto.
3. Average measurements: RBW = 1MHz, VBW = 10 Hz, Sweep: Auto.
4. “ \* ”, means this data is the worst emission level.
5. Measurement Level = Reading Level + Correct Factor.
6. The average measurement was not performed when the peak measured data under the limit of average detection.

Product : Intel® Dual Band Wireless-AC 8260  
 Test Item : Band Edge  
 Test Site : No.3 OATS  
 Test Mode : Mode 1 SISO A: Transmit (802.11b 1Mbps)

**RF Radiated Measurement (Vertical):**

Channel No.	Frequency (MHz)	Correct Factor (dB)	Reading Level (dBuV)	Emission Level (dBuV/m)	Peak Limit (dBuV/m)	Average Limit (dBuV/m)	Result
10 (Peak)	2458.700	31.268	76.445	107.713	--	--	Pass
10 (Peak)	2483.500	31.435	36.433	67.868	74.00	54.00	Pass
10 (Average)	2456.100	31.250	71.130	102.380	--	--	Pass
10 (Average)	2483.500	31.435	20.808	52.243	74.00	54.00	Pass

**Figure Channel 10: Vertical (Peak)**

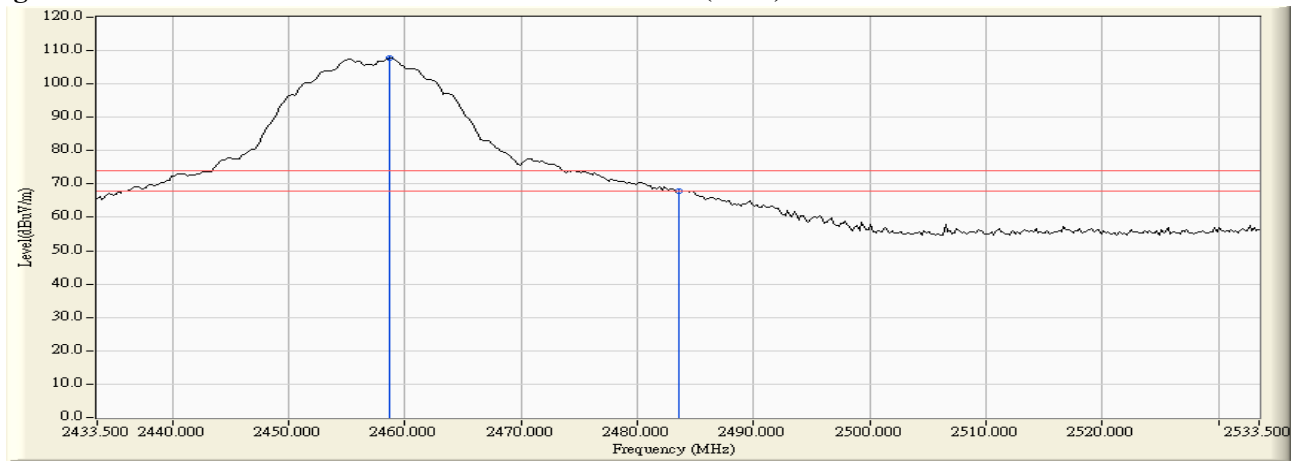

**Figure Channel 10: Vertical (Average)**



Note:

1. All readings above 1GHz are performed with peak and/or average measurements as necessary.
2. Peak measurements: RBW = 1MHz, VBW = 3 MHz, Sweep: Auto.
3. Average measurements: RBW = 1MHz, VBW = 10 Hz, Sweep: Auto.
4. “ \* ”, means this data is the worst emission level.
5. Measurement Level = Reading Level + Correct Factor.
6. The average measurement was not performed when the peak measured data under the limit of average detection.

Product : Intel® Dual Band Wireless-AC 8260  
 Test Item : Band Edge  
 Test Site : No.3 OATS  
 Test Mode : Mode 1 SISO A: Transmit (802.11b 1Mbps)

**RF Radiated Measurement (Horizontal):**

Channel No.	Frequency (MHz)	Correct Factor (dB)	Reading Level (dBuV)	Emission Level (dBuV/m)	Peak Limit (dBuV/m)	Average Limit (dBuV/m)	Result
11 (Peak)	2463.700	32.032	76.635	108.667	--	--	Pass
11 (Peak)	2483.500	32.182	39.366	71.548	74.00	54.00	Pass
11 (Average)	2461.300	32.014	71.997	104.011	--	--	Pass
11 (Average)	2483.500	32.182	17.348	49.530	74.00	54.00	Pass
11 (Average)	2488.700	32.222	21.617	53.838	74.00	54.00	Pass

**Figure Channel 11: Horizontal (Peak)**

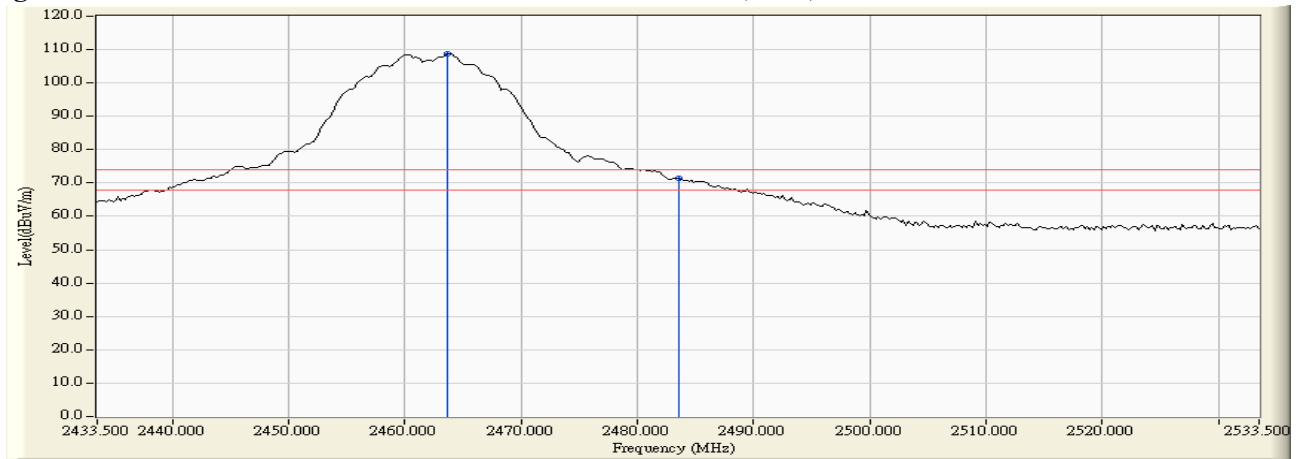

**Figure Channel 11: Horizontal (Average)**

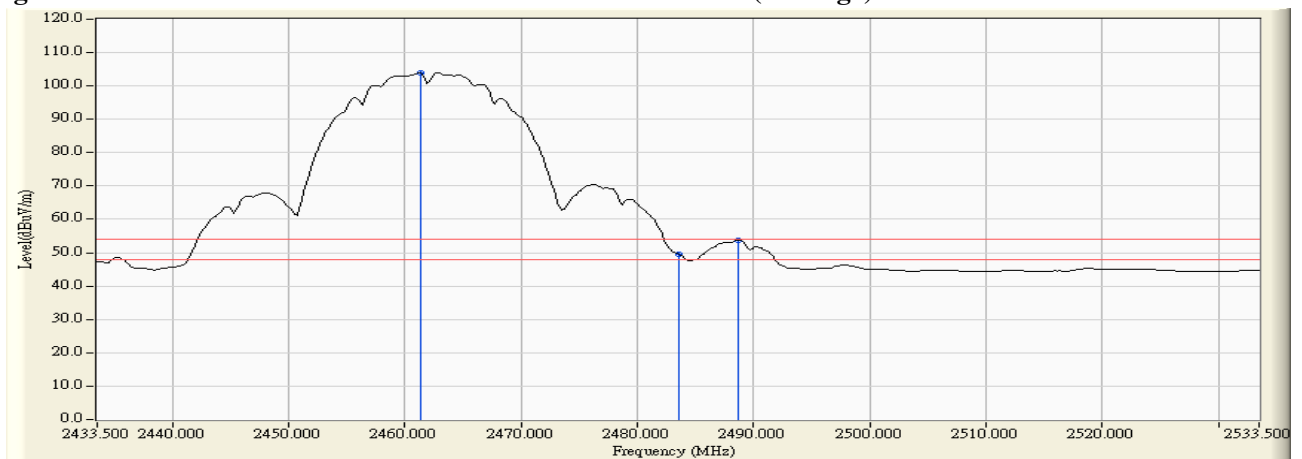

Note:

1. All readings above 1GHz are performed with peak and/or average measurements as necessary.
2. Peak measurements: RBW = 1MHz, VBW = 3 MHz, Sweep: Auto.
3. Average measurements: RBW = 1MHz, VBW = 10 Hz, Sweep: Auto.
4. “ \* ”, means this data is the worst emission level.
5. Measurement Level = Reading Level + Correct Factor.
6. The average measurement was not performed when the peak measured data under the limit of average detection.



Product : Intel® Dual Band Wireless-AC 8260  
 Test Item : Band Edge  
 Test Site : No.3 OATS  
 Test Mode : Mode 1 SISO A: Transmit (802.11b 1Mbps)

**RF Radiated Measurement (Vertical):**

Channel No.	Frequency (MHz)	Correct Factor (dB)	Reading Level (dBuV)	Emission Level (dBuV/m)	Peak Limit (dBuV/m)	Average Limit (dBuV/m)	Result
11 (Peak)	2463.700	31.302	76.857	108.159	--	--	Pass
11 (Peak)	2483.500	31.435	39.596	71.031	74.00	54.00	Pass
11 (Average)	2461.300	31.286	71.391	102.677	--	--	Pass
11 (Average)	2483.500	31.435	17.338	48.773	74.00	54.00	Pass
11 (Average)	2488.900	31.472	21.539	53.011	74.00	54.00	Pass

**Figure Channel 11: Vertical (Peak)**

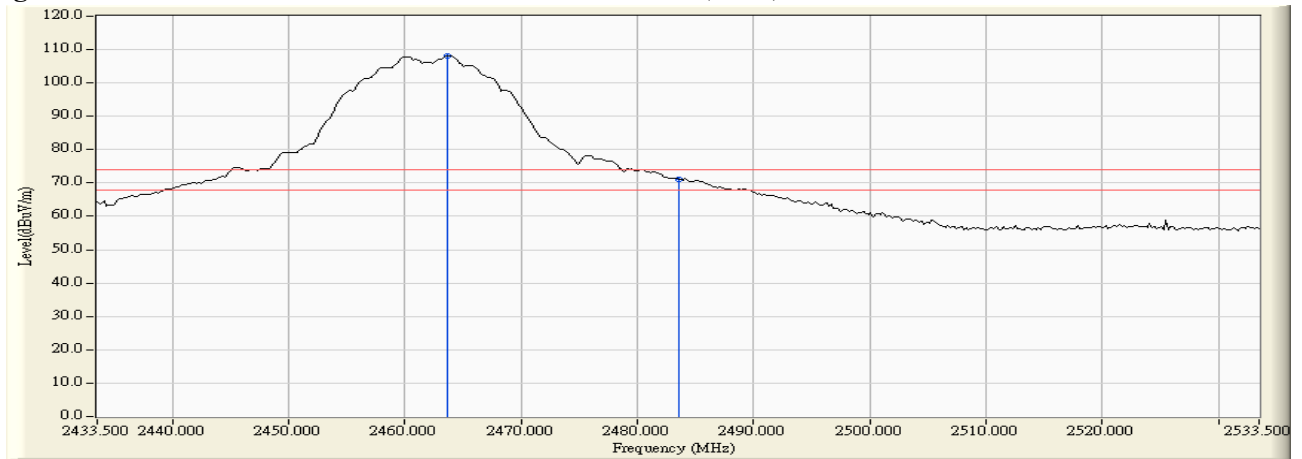

**Figure Channel 11: Vertical (Average)**

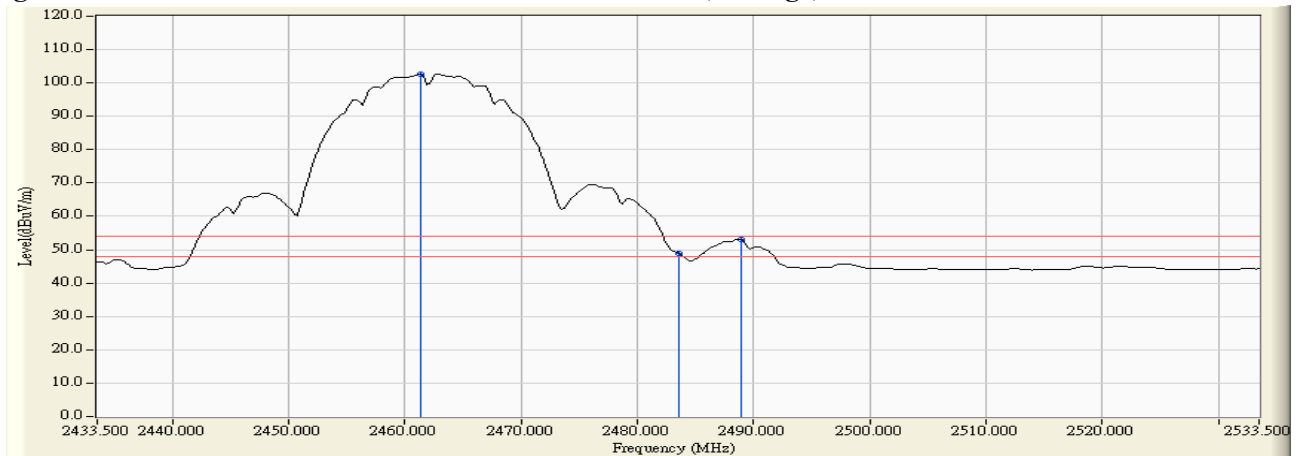

Note:

1. All readings above 1GHz are performed with peak and/or average measurements as necessary.
2. Peak measurements: RBW = 1MHz, VBW = 3 MHz, Sweep: Auto.
3. Average measurements: RBW = 1MHz, VBW = 10 Hz, Sweep: Auto.
4. “ \* ”, means this data is the worst emission level.
5. Measurement Level = Reading Level + Correct Factor.
6. The average measurement was not performed when the peak measured data under the limit of average detection.

Product : Intel® Dual Band Wireless-AC 8260  
 Test Item : Band Edge  
 Test Site : No.3 OATS  
 Test Mode : Mode 1 SISO A: Transmit (802.11b 1Mbps)

**RF Radiated Measurement (Horizontal):**

Channel No.	Frequency (MHz)	Correct Factor (dB)	Reading Level (dBuV)	Emission Level (dBuV/m)	Peak Limit (dBuV/m)	Average Limit (dBuV/m)	Result
12 (Peak)	2468.700	32.070	74.416	106.486	--	--	Pass
12 (Peak)	2483.500	32.182	39.429	71.611	74.00	54.00	Pass
12 (Average)	2466.300	32.052	69.219	101.271	--	--	Pass
12 (Average)	2483.500	32.182	20.539	52.721	74.00	54.00	Pass
12 (Average)	2484.500	32.190	21.090	53.280	74.00	54.00	Pass

**Figure Channel 12: Horizontal (Peak)**

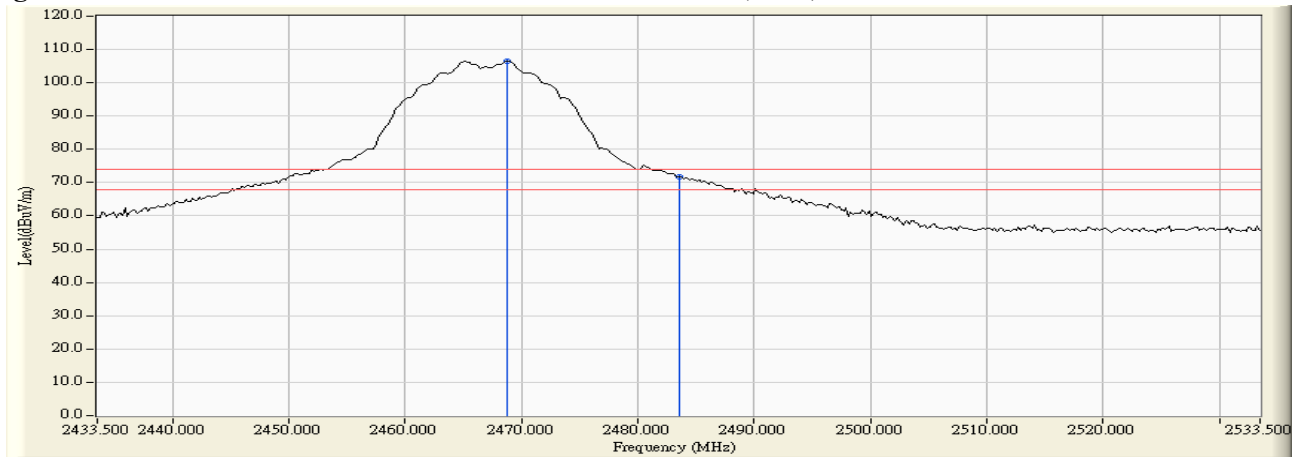

**Figure Channel 12: Horizontal (Average)**

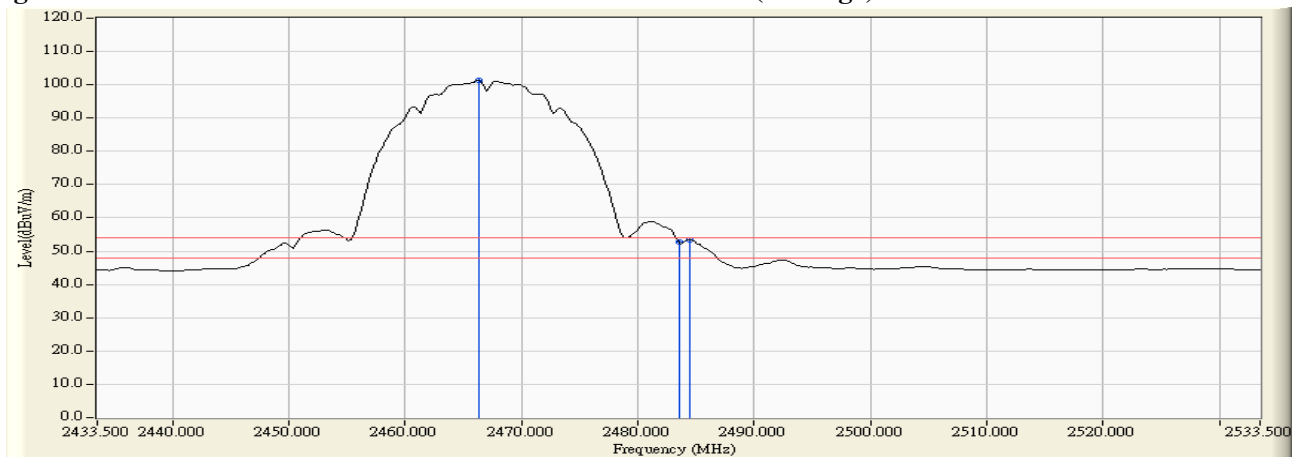

Note:

1. All readings above 1GHz are performed with peak and/or average measurements as necessary.
2. Peak measurements: RBW = 1MHz, VBW = 3 MHz, Sweep: Auto.
3. Average measurements: RBW = 1MHz, VBW = 10 Hz, Sweep: Auto.
4. “ \* ”, means this data is the worst emission level.
5. Measurement Level = Reading Level + Correct Factor.
6. The average measurement was not performed when the peak measured data under the limit of average detection.

Product : Intel® Dual Band Wireless-AC 8260  
 Test Item : Band Edge  
 Test Site : No.3 OATS  
 Test Mode : Mode 1 SISO A: Transmit (802.11b 1Mbps)

**RF Radiated Measurement (Vertical):**

Channel No.	Frequency (MHz)	Correct Factor (dB)	Reading Level (dBuV)	Emission Level (dBuV/m)	Peak Limit (dBuV/m)	Average Limit (dBuV/m)	Result
12 (Peak)	2468.700	31.336	73.489	104.824	--	--	Pass
12 (Peak)	2483.500	31.435	39.208	70.643	74.00	54.00	Pass
12 (Average)	2466.300	31.319	68.196	99.515	--	--	Pass
12 (Average)	2483.500	31.435	20.135	51.570	74.00	54.00	Pass

**Figure Channel 12: Vertical (Peak)**

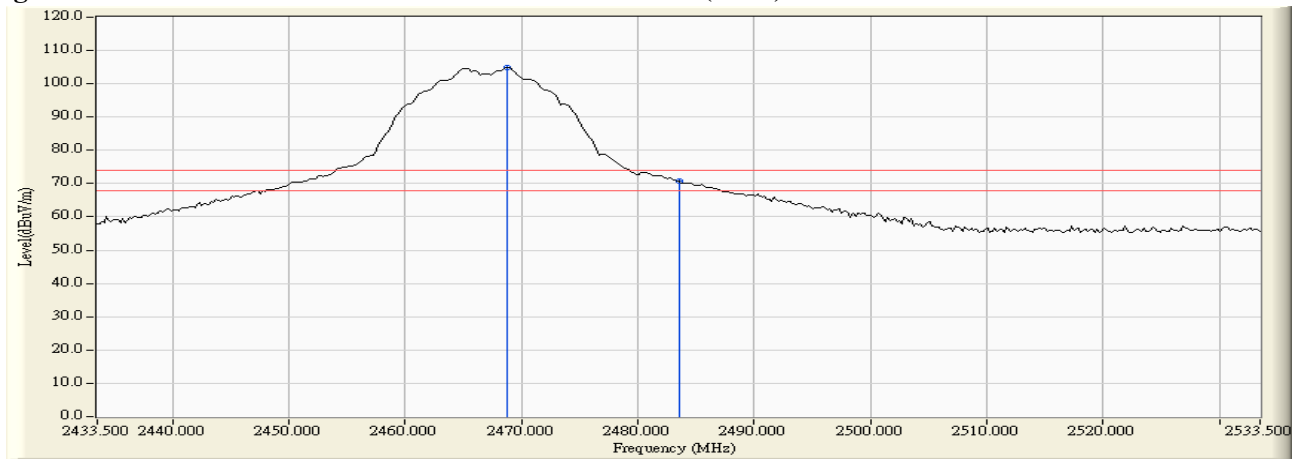

**Figure Channel 12: Vertical (Average)**

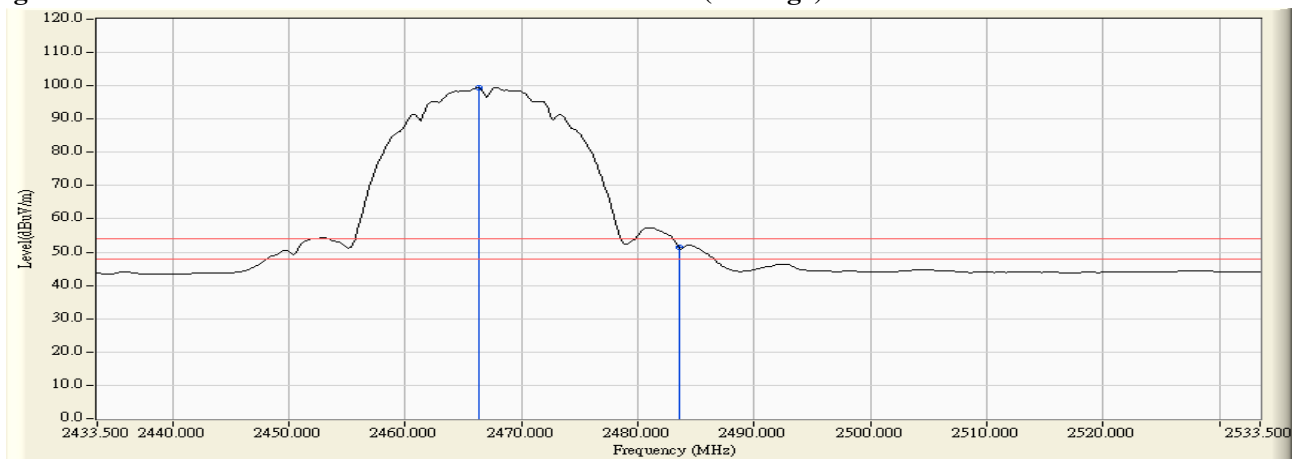

Note:

1. All readings above 1GHz are performed with peak and/or average measurements as necessary.
2. Peak measurements: RBW = 1MHz, VBW = 3 MHz, Sweep: Auto.
3. Average measurements: RBW = 1MHz, VBW = 10 Hz, Sweep: Auto.
4. “ \* ”, means this data is the worst emission level.
5. Measurement Level = Reading Level + Correct Factor.
6. The average measurement was not performed when the peak measured data under the limit of average detection.

Product : Intel® Dual Band Wireless-AC 8260  
 Test Item : Band Edge  
 Test Site : No.3 OATS  
 Test Mode : Mode 1 SISO A: Transmit (802.11g 6Mbps)

**RF Radiated Measurement (Horizontal):**

Channel No.	Frequency (MHz)	Correct Factor (dB)	Reading Level (dBuV)	Emission Level (dBuV/m)	Peak Limit (dBuV/m)	Average Limit (dBuV/m)	Result
01 (Peak)	2389.600	31.508	41.882	73.390	74.00	54.00	Pass
01 (Peak)	2390.000	31.509	41.986	73.495	74.00	54.00	Pass
01 (Peak)	2400.000	31.561	58.172	89.733	74.00	54.00	Pass
01 (Peak)	2416.000	31.670	78.845	110.514	--	--	Pass
01 (Average)	2390.000	31.509	22.056	53.565	74.00	54.00	Pass
01 (Average)	2400.000	31.561	39.004	70.565	74.00	54.00	Pass
01 (Average)	2415.200	31.662	67.747	99.410	--	--	Pass

**Figure Channel 01:**

**Horizontal (Peak)**

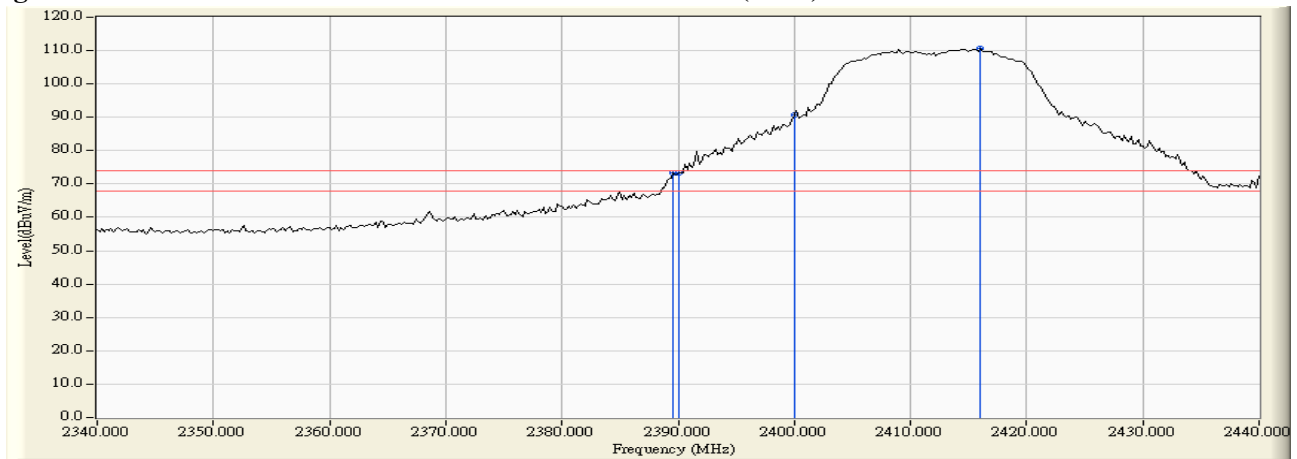

**Figure Channel 01:**

**Horizontal (Average)**

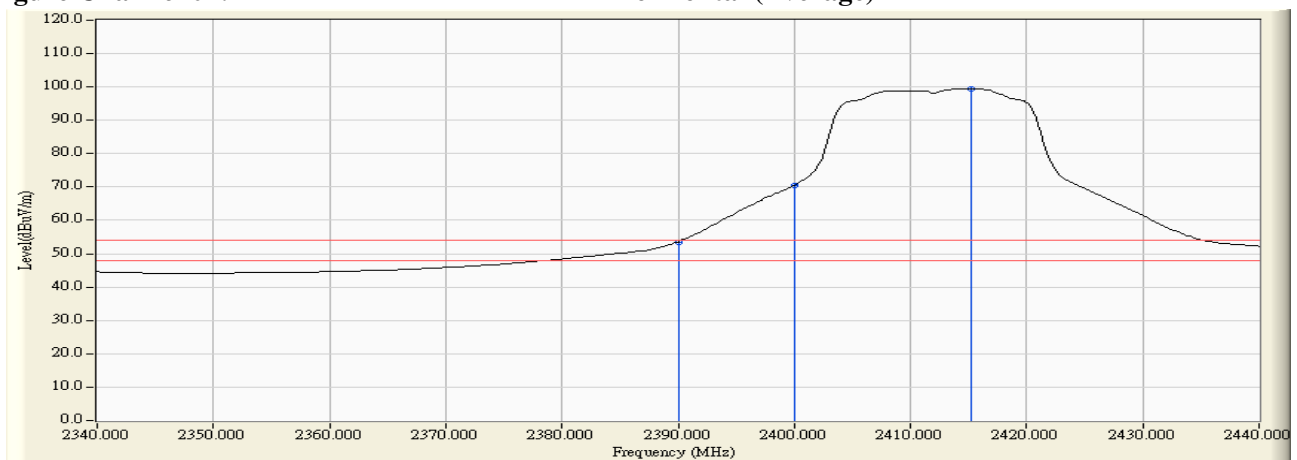

Note:

1. All readings above 1GHz are performed with peak and/or average measurements as necessary.
2. Peak measurements: RBW = 1MHz, VBW = 3 MHz, Sweep: Auto.
3. Average measurements: RBW = 1MHz, VBW = 10 Hz, Sweep: Auto.
4. “ \* ”, means this data is the worst emission level.
5. Measurement Level = Reading Level + Correct Factor.
6. The average measurement was not performed when the peak measured data under the limit of average detection.



Product : Intel® Dual Band Wireless-AC 8260  
 Test Item : Band Edge  
 Test Site : No.3 OATS  
 Test Mode : Mode 1 SISO A: Transmit (802.11g 6Mbps)

**RF Radiated Measurement (Vertical):**

Channel No.	Frequency (MHz)	Correct Factor (dB)	Reading Level (dBuV)	Emission Level (dBuV/m)	Peak Limit (dBuV/m)	Average Limit (dBuV/m)	Result
01 (Peak)	2390.000	30.915	40.679	71.594	74.00	54.00	Pass
01 (Peak)	2400.000	30.912	55.268	86.180	74.00	54.00	Pass
01 (Peak)	2414.200	30.964	76.390	107.354	--	--	Pass
01 (Average)	2390.000	30.915	21.291	52.206	74.00	54.00	Pass
01 (Average)	2400.000	30.912	37.280	68.192	74.00	54.00	Pass
01 (Average)	2415.200	30.971	65.207	96.178	--	--	Pass

**Figure Channel 01: Vertical (Peak)**

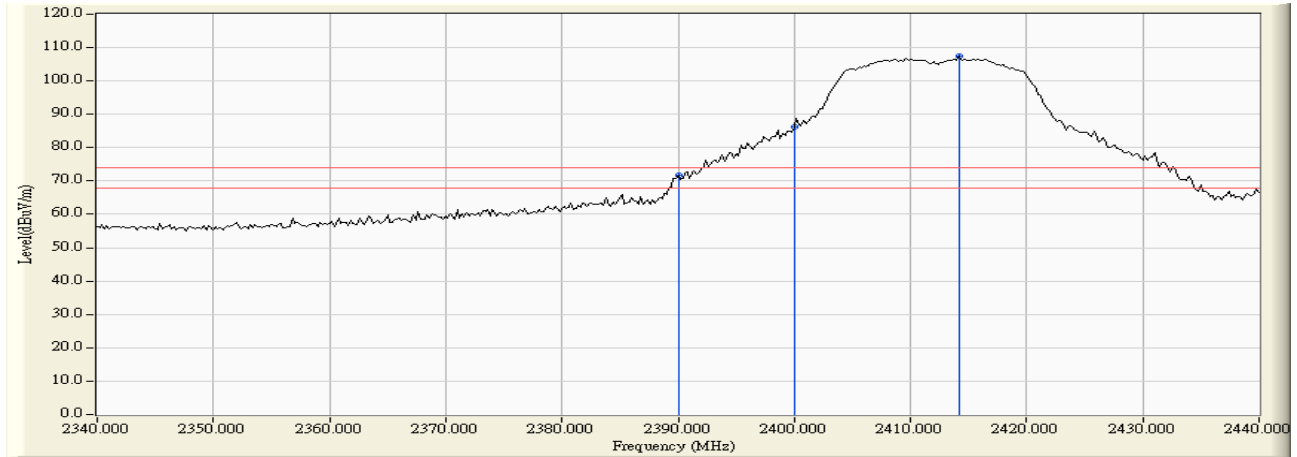

**Figure Channel 01: Vertical (Average)**

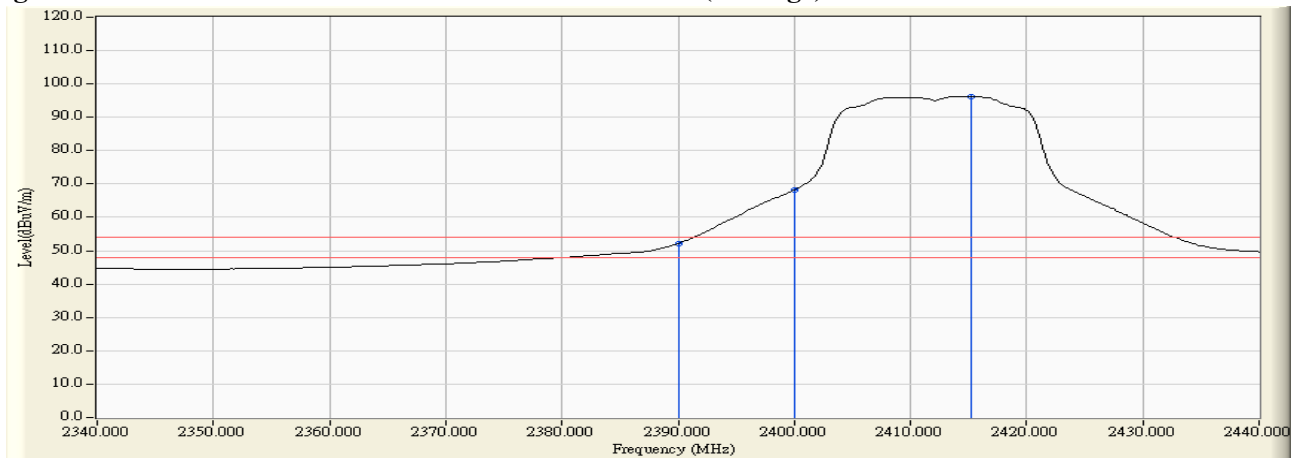

Note:

1. All readings above 1GHz are performed with peak and/or average measurements as necessary.
2. Peak measurements: RBW = 1MHz, VBW = 3 MHz, Sweep: Auto.
3. Average measurements: RBW = 1MHz, VBW = 10 Hz, Sweep: Auto.
4. “ \* ”, means this data is the worst emission level.
5. Measurement Level = Reading Level + Correct Factor.
6. The average measurement was not performed when the peak measured data under the limit of average detection.

Product : Intel® Dual Band Wireless-AC 8260  
 Test Item : Band Edge  
 Test Site : No.3 OATS  
 Test Mode : Mode 1 SISO A: Transmit (802.11g 6Mbps)

**RF Radiated Measurement (Horizontal):**

Channel No.	Frequency (MHz)	Correct Factor (dB)	Reading Level (dBuV)	Emission Level (dBuV/m)	Peak Limit (dBuV/m)	Average Limit (dBuV/m)	Result
02 (Peak)	2390.000	31.509	36.563	68.072	74.00	54.00	Pass
02 (Peak)	2400.000	31.561	54.318	85.879	74.00	54.00	Pass
02 (Peak)	2419.200	31.694	79.211	110.904	--	--	Pass
02 (Average)	2390.000	31.509	21.753	53.262	74.00	54.00	Pass
02 (Average)	2400.000	31.561	37.392	68.953	74.00	54.00	Pass
02 (Average)	2420.400	31.702	68.608	100.311	--	--	Pass

**Figure Channel 02:**

**Horizontal (Peak)**

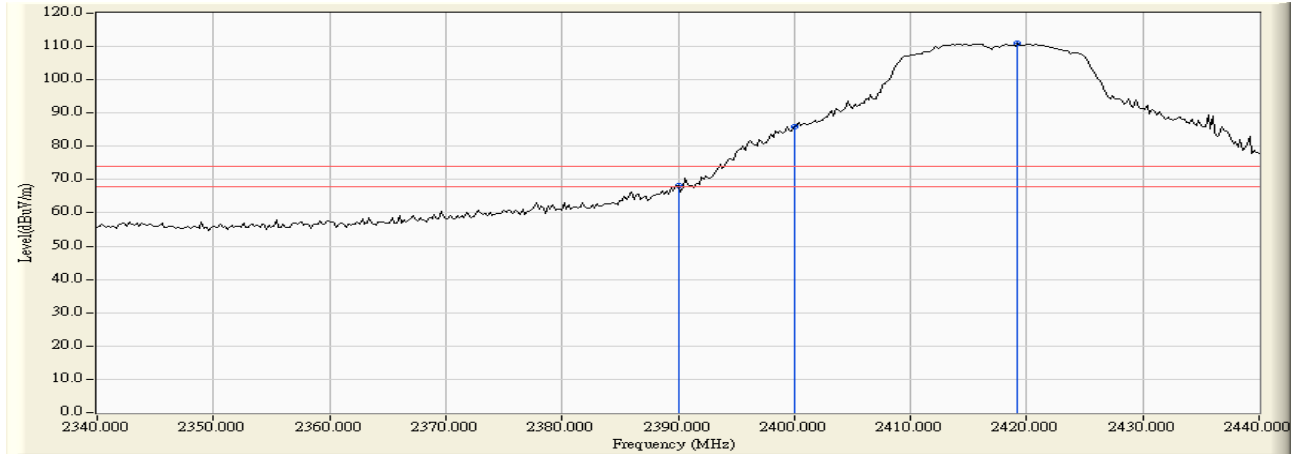

**Figure Channel 02:**

**Horizontal (Average)**

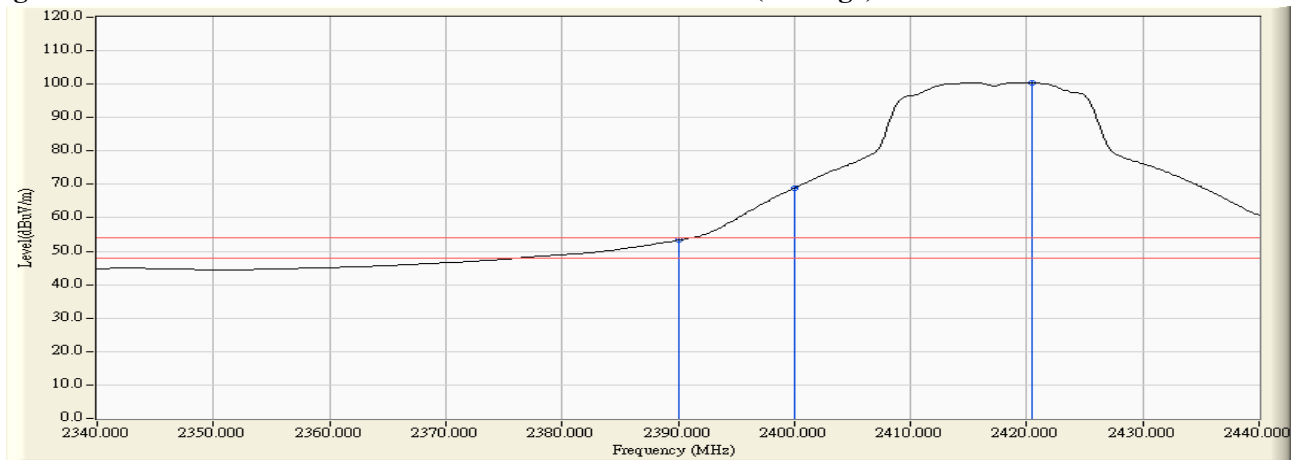

Note:

1. All readings above 1GHz are performed with peak and/or average measurements as necessary.
2. Peak measurements: RBW = 1MHz, VBW = 3 MHz, Sweep: Auto.
3. Average measurements: RBW = 1MHz, VBW = 10 Hz, Sweep: Auto.
4. “ \* ”, means this data is the worst emission level.
5. Measurement Level = Reading Level + Correct Factor.
6. The average measurement was not performed when the peak measured data under the limit of average detection.

Product : Intel® Dual Band Wireless-AC 8260  
 Test Item : Band Edge  
 Test Site : No.3 OATS  
 Test Mode : Mode 1 SISO A: Transmit (802.11g 6Mbps)

**RF Radiated Measurement (Vertical):**

Channel No.	Frequency (MHz)	Correct Factor (dB)	Reading Level (dBuV)	Emission Level (dBuV/m)	Peak Limit (dBuV/m)	Average Limit (dBuV/m)	Result
02 (Peak)	2390.000	30.915	34.995	65.910	74.00	54.00	Pass
02 (Peak)	2400.000	30.912	53.532	84.444	74.00	54.00	Pass
02 (Peak)	2420.600	31.007	77.599	108.607	--	--	Pass
02 (Average)	2390.000	30.915	21.093	52.008	74.00	54.00	Pass
02 (Average)	2400.000	30.912	36.241	67.153	74.00	54.00	Pass
02 (Average)	2420.200	31.005	66.602	97.607	--	--	Pass

**Figure Channel 02: Vertical (Peak)**

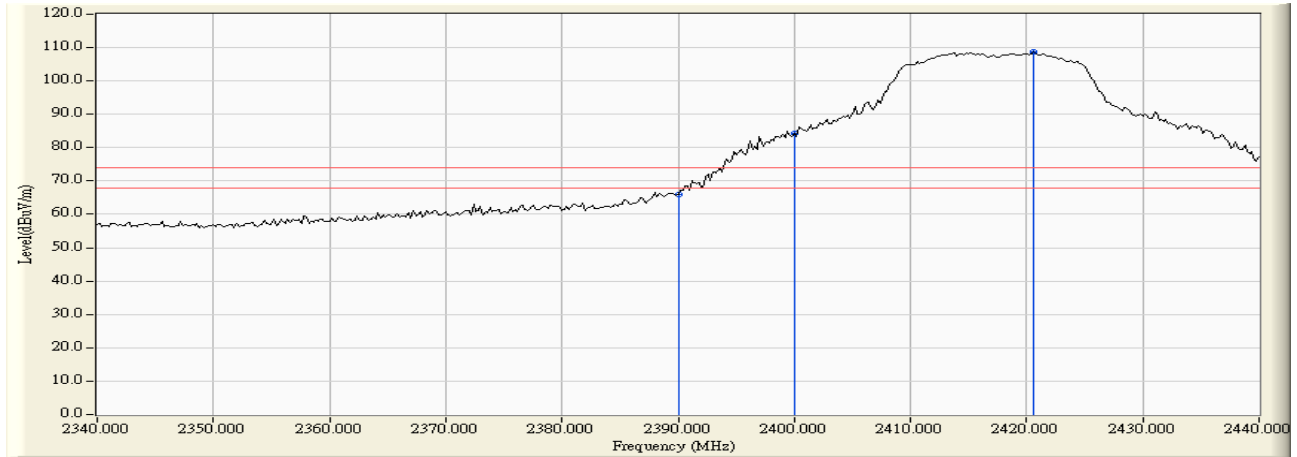

**Figure Channel 02: Vertical (Average)**

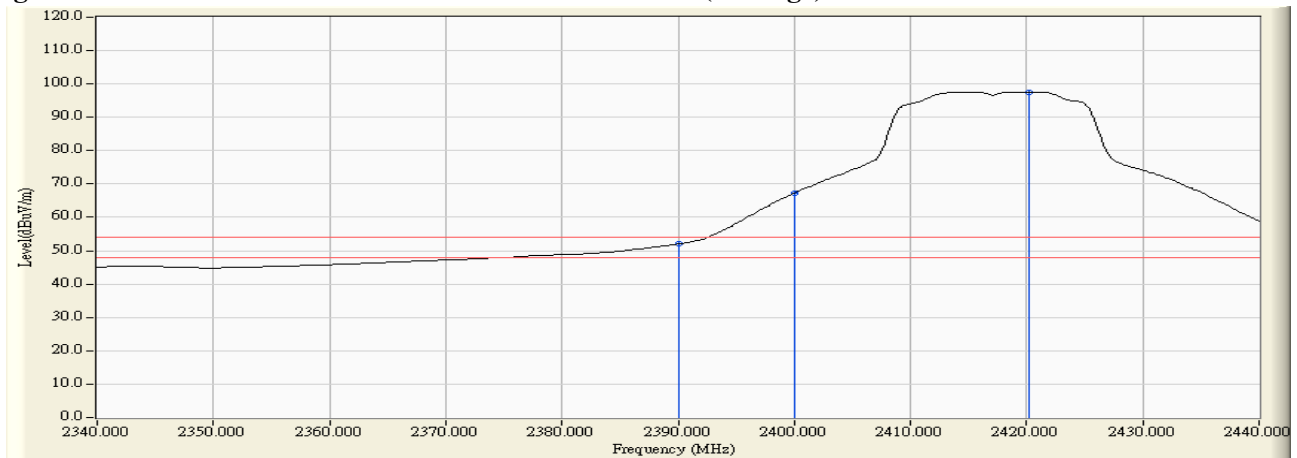

Note:

1. All readings above 1GHz are performed with peak and/or average measurements as necessary.
2. Peak measurements: RBW = 1MHz, VBW = 3 MHz, Sweep: Auto.
3. Average measurements: RBW = 1MHz, VBW = 10 Hz, Sweep: Auto.
4. “ \* ”, means this data is the worst emission level.
5. Measurement Level = Reading Level + Correct Factor.
6. The average measurement was not performed when the peak measured data under the limit of average detection.

Product : Intel® Dual Band Wireless-AC 8260  
 Test Item : Band Edge  
 Test Site : No.3 OATS  
 Test Mode : Mode 1 SISO A: Transmit (802.11g 6Mbps)

**RF Radiated Measurement (Horizontal):**

Channel No.	Frequency (MHz)	Correct Factor (dB)	Reading Level (dBuV)	Emission Level (dBuV/m)	Peak Limit (dBuV/m)	Average Limit (dBuV/m)	Result
10 (Peak)	2454.300	31.961	79.490	111.451	--	--	Pass
10 (Peak)	2483.500	32.182	35.498	67.680	74.00	54.00	Pass
10 (Average)	2458.700	31.994	68.381	100.375	--	--	Pass
10 (Average)	2483.500	32.182	20.998	53.180	74.00	54.00	Pass

**Figure Channel 10: Horizontal (Peak)**

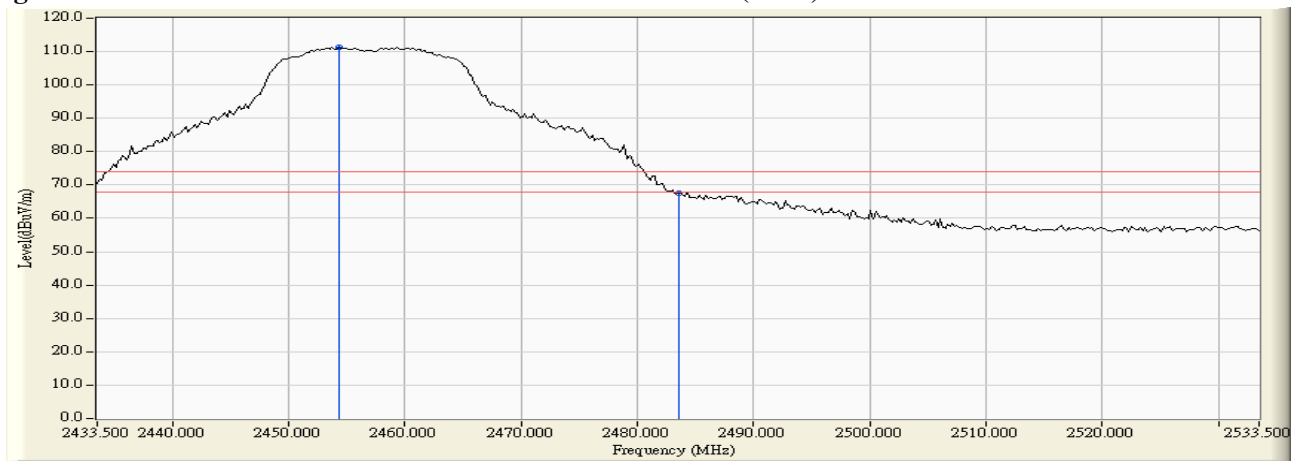

**Figure Channel 10: Horizontal (Average)**

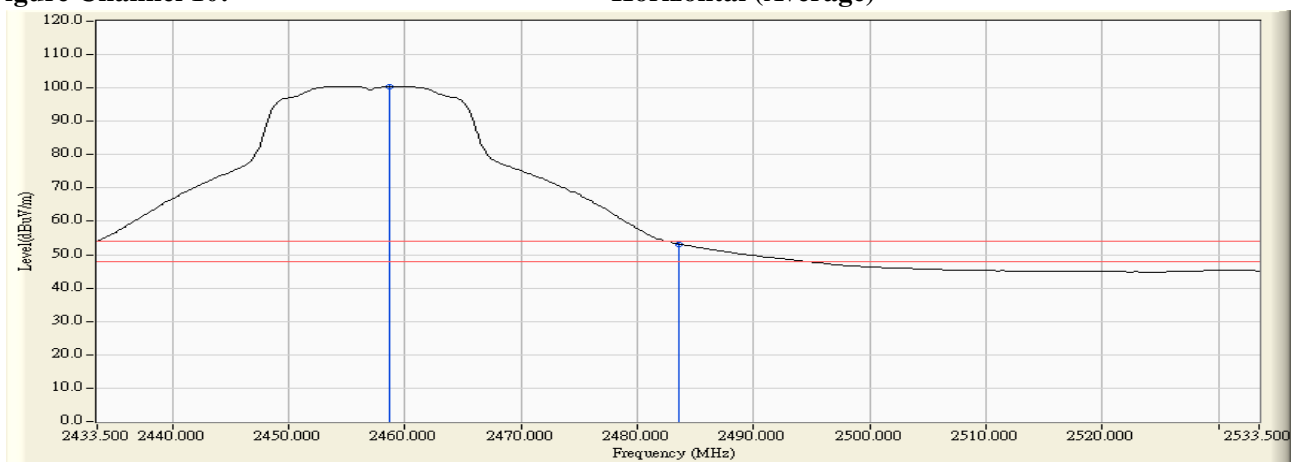

Note:

1. All readings above 1GHz are performed with peak and/or average measurements as necessary.
2. Peak measurements: RBW = 1MHz, VBW = 3 MHz, Sweep: Auto.
3. Average measurements: RBW = 1MHz, VBW = 10 Hz, Sweep: Auto.
4. “ \* ”, means this data is the worst emission level.
5. Measurement Level = Reading Level + Correct Factor.
6. The average measurement was not performed when the peak measured data under the limit of average detection.



Product : Intel® Dual Band Wireless-AC 8260  
 Test Item : Band Edge  
 Test Site : No.3 OATS  
 Test Mode : Mode 1 SISO A: Transmit (802.11g 6Mbps)

**RF Radiated Measurement (Vertical):**

Channel No.	Frequency (MHz)	Correct Factor (dB)	Reading Level (dBuV)	Emission Level (dBuV/m)	Peak Limit (dBuV/m)	Average Limit (dBuV/m)	Result
10 (Peak)	2459.900	31.276	75.389	106.665	--	--	Pass
10 (Peak)	2483.500	31.435	31.514	62.949	74.00	54.00	Pass
10 (Peak)	2486.300	31.454	32.115	63.569	74.00	54.00	Pass
10 (Average)	2459.900	31.276	65.007	96.283	--	--	Pass
10 (Average)	2483.500	31.435	18.957	50.392	74.00	54.00	Pass

**Figure Channel 10: Vertical (Peak)**

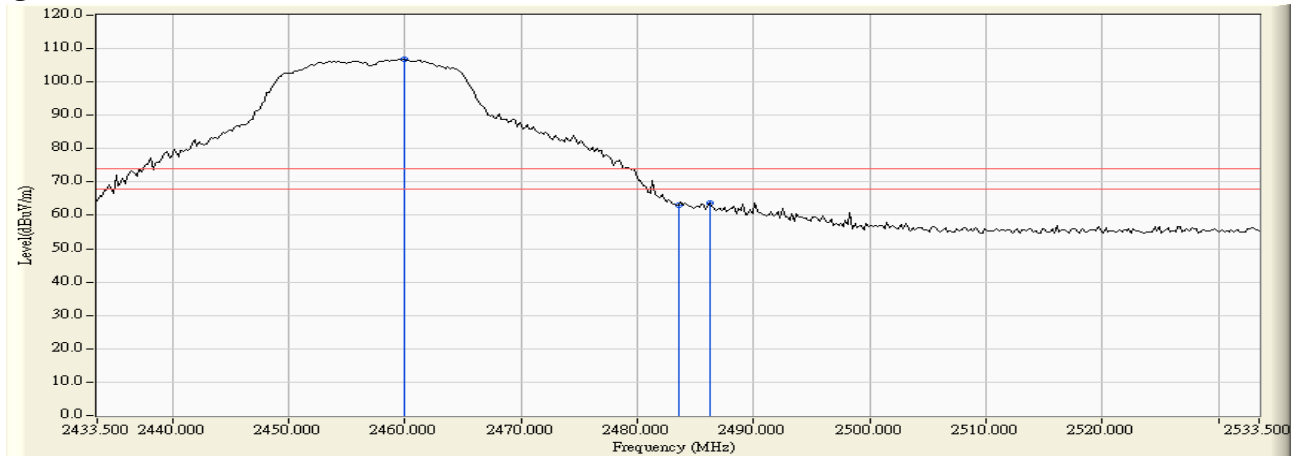

**Figure Channel 10: Vertical (Average)**

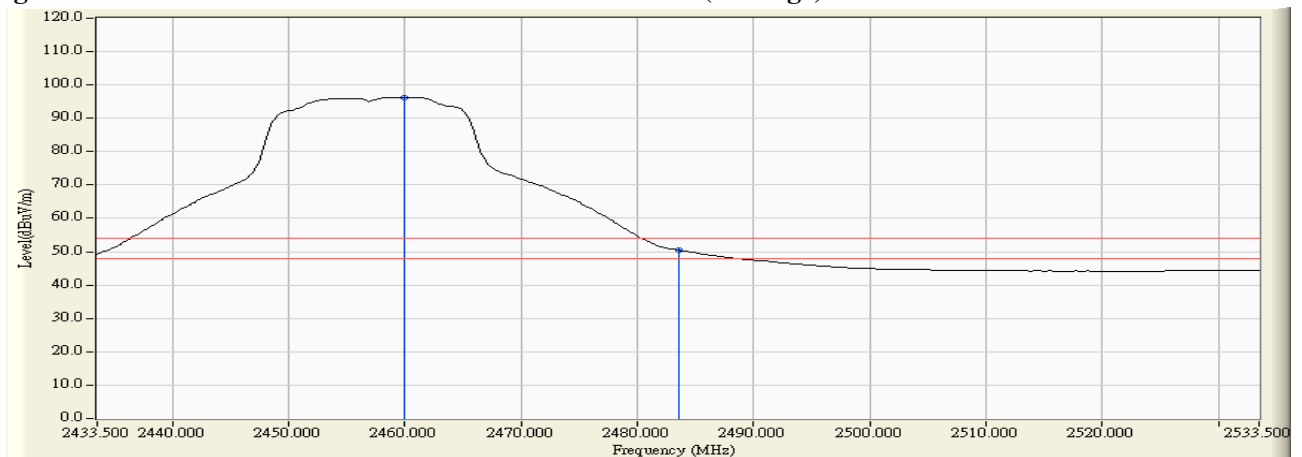

Note:

1. All readings above 1GHz are performed with peak and/or average measurements as necessary.
2. Peak measurements: RBW = 1MHz, VBW = 3 MHz, Sweep: Auto.
3. Average measurements: RBW = 1MHz, VBW = 10 Hz, Sweep: Auto.
4. “ \* ”, means this data is the worst emission level.
5. Measurement Level = Reading Level + Correct Factor.
6. The average measurement was not performed when the peak measured data under the limit of average detection.

Product : Intel® Dual Band Wireless-AC 8260  
 Test Item : Band Edge  
 Test Site : No.3 OATS  
 Test Mode : Mode 1 SISO A: Transmit (802.11g 6Mbps)

**RF Radiated Measurement (Horizontal):**

Channel No.	Frequency (MHz)	Correct Factor (dB)	Reading Level (dBuV)	Emission Level (dBuV/m)	Peak Limit (dBuV/m)	Average Limit (dBuV/m)	Result
11 (Peak)	2465.500	32.046	77.348	109.394	--	--	Pass
11 (Peak)	2483.500	32.182	37.058	69.240	74.00	54.00	Pass
11 (Average)	2458.700	31.994	66.512	98.506	--	--	Pass
11 (Average)	2483.500	32.182	21.592	53.774	74.00	54.00	Pass

**Figure Channel 11: Horizontal (Peak)**

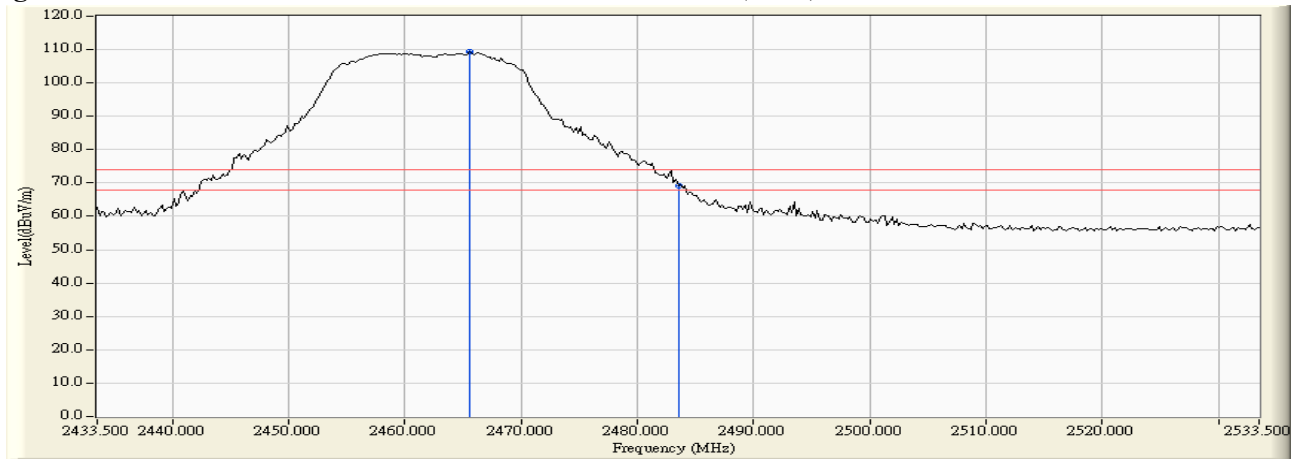

**Figure Channel 11: Horizontal (Average)**

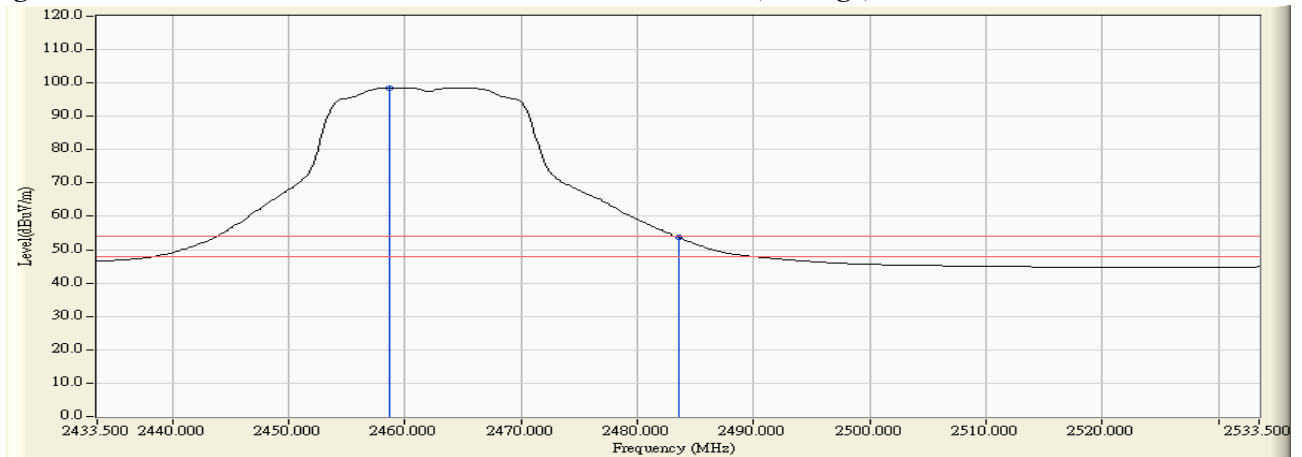

Note:

1. All readings above 1GHz are performed with peak and/or average measurements as necessary.
2. Peak measurements: RBW = 1MHz, VBW = 3 MHz, Sweep: Auto.
3. Average measurements: RBW = 1MHz, VBW = 10 Hz, Sweep: Auto.
4. “ \* ”, means this data is the worst emission level.
5. Measurement Level = Reading Level + Correct Factor.
6. The average measurement was not performed when the peak measured data under the limit of average detection.

Product : Intel® Dual Band Wireless-AC 8260  
 Test Item : Band Edge  
 Test Site : No.3 OATS  
 Test Mode : Mode 1 SISO A: Transmit (802.11g 6Mbps)

**RF Radiated Measurement (Vertical):**

Channel No.	Frequency (MHz)	Correct Factor (dB)	Reading Level (dBuV)	Emission Level (dBuV/m)	Peak Limit (dBuV/m)	Average Limit (dBuV/m)	Result
11 (Peak)	2459.500	31.273	74.436	105.709	--	--	Pass
11 (Peak)	2483.500	31.435	33.274	64.709	74.00	54.00	Pass
11 (Average)	2465.500	31.314	63.985	95.299	--	--	Pass
11 (Average)	2483.500	31.435	18.946	50.381	74.00	54.00	Pass

**Figure Channel 11: Vertical (Peak)**

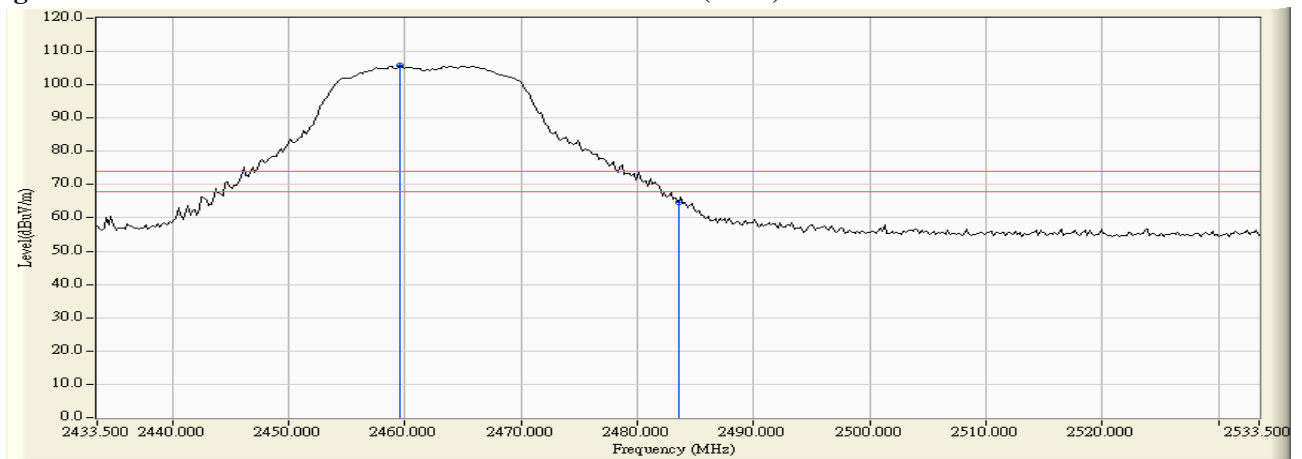

**Figure Channel 11: Vertical (Average)**

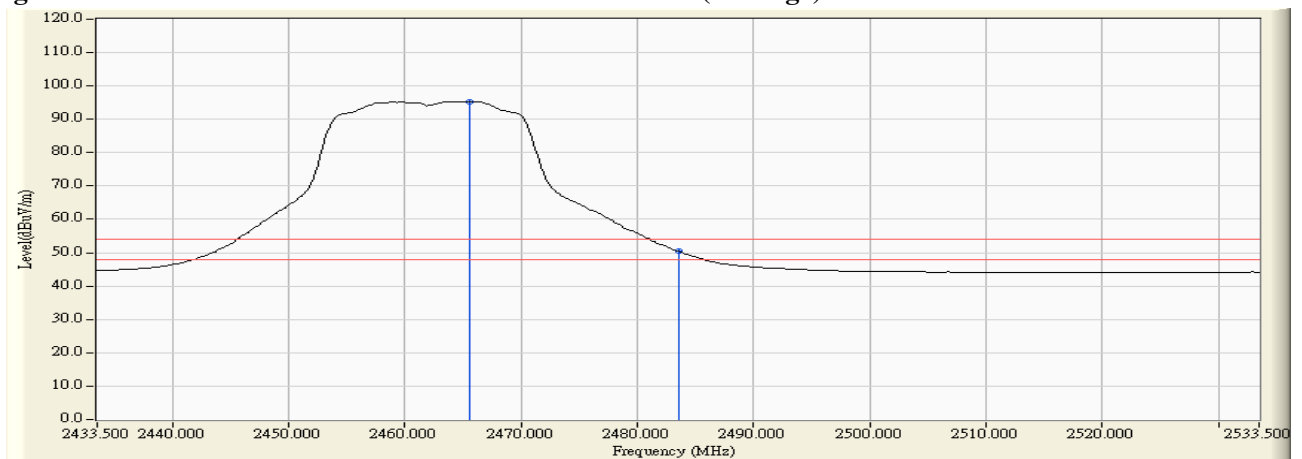

Note:

1. All readings above 1GHz are performed with peak and/or average measurements as necessary.
2. Peak measurements: RBW = 1MHz, VBW = 3 MHz, Sweep: Auto.
3. Average measurements: RBW = 1MHz, VBW = 10 Hz, Sweep: Auto.
4. “ \* ”, means this data is the worst emission level.
5. Measurement Level = Reading Level + Correct Factor.
6. The average measurement was not performed when the peak measured data under the limit of average detection.

Product : Intel® Dual Band Wireless-AC 8260  
 Test Item : Band Edge  
 Test Site : No.3 OATS  
 Test Mode : Mode 1 SISO A: Transmit (802.11g 6Mbps)

**RF Radiated Measurement (Horizontal):**

Channel No.	Frequency (MHz)	Correct Factor (dB)	Reading Level (dBuV)	Emission Level (dBuV/m)	Peak Limit (dBuV/m)	Average Limit (dBuV/m)	Result
12 (Peak)	2470.900	32.087	73.102	105.189	--	--	Pass
12 (Peak)	2483.500	32.182	38.855	71.037	74.00	54.00	Pass
12 (Average)	2468.900	32.072	62.171	94.243	--	--	Pass
12 (Average)	2483.500	32.182	21.247	53.429	74.00	54.00	Pass

**Figure Channel 12: Horizontal (Peak)**

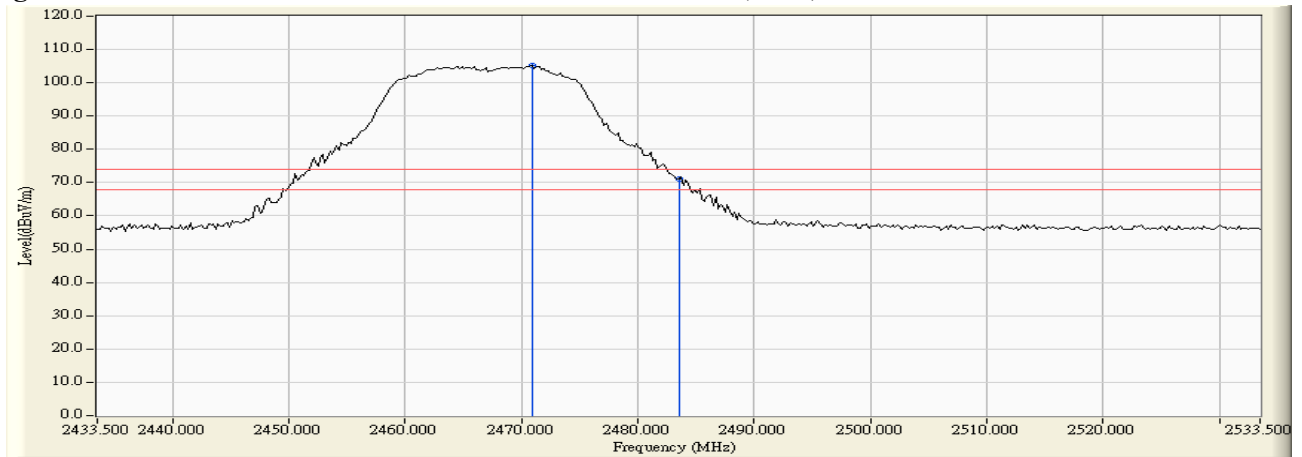

**Figure Channel 12: Horizontal (Average)**

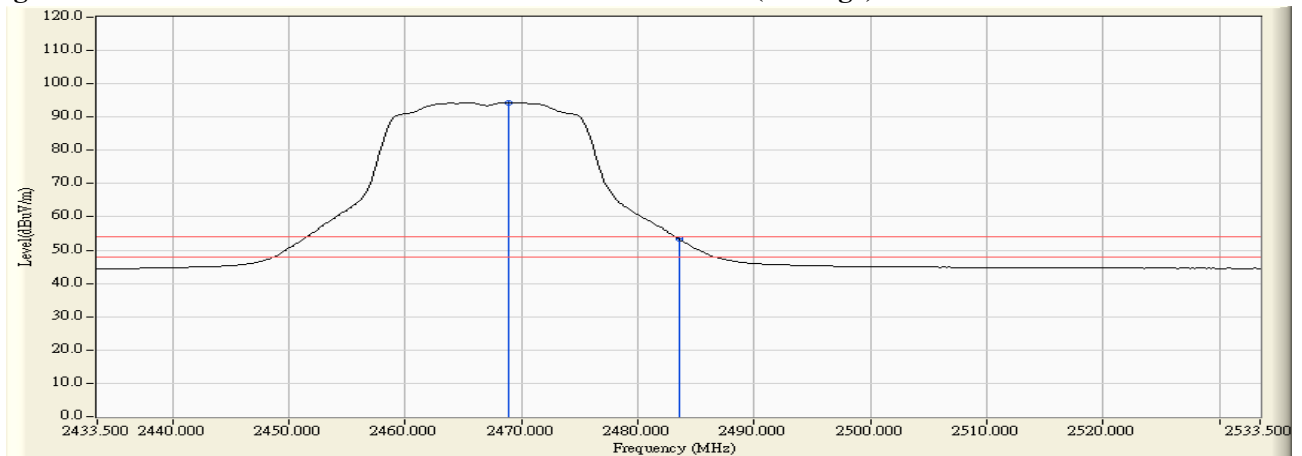

Note:

1. All readings above 1GHz are performed with peak and/or average measurements as necessary.
2. Peak measurements: RBW = 1MHz, VBW = 3 MHz, Sweep: Auto.
3. Average measurements: RBW = 1MHz, VBW = 10 Hz, Sweep: Auto.
4. “ \* ”, means this data is the worst emission level.
5. Measurement Level = Reading Level + Correct Factor.
6. The average measurement was not performed when the peak measured data under the limit of average detection.



Product : Intel® Dual Band Wireless-AC 8260  
 Test Item : Band Edge  
 Test Site : No.3 OATS  
 Test Mode : Mode 1 SISO A: Transmit (802.11g 6Mbps)

**RF Radiated Measurement (Vertical):**

Channel No.	Frequency (MHz)	Correct Factor (dB)	Reading Level (dBuV)	Emission Level (dBuV/m)	Peak Limit (dBuV/m)	Average Limit (dBuV/m)	Result
12 (Peak)	2464.700	31.308	69.660	100.969	--	--	Pass
12 (Peak)	2483.500	31.435	33.958	65.393	74.00	54.00	Pass
12 (Average)	2465.700	31.315	58.395	89.710	--	--	Pass
12 (Average)	2483.500	31.435	17.399	48.834	74.00	54.00	Pass

**Figure Channel 12: Vertical (Peak)**

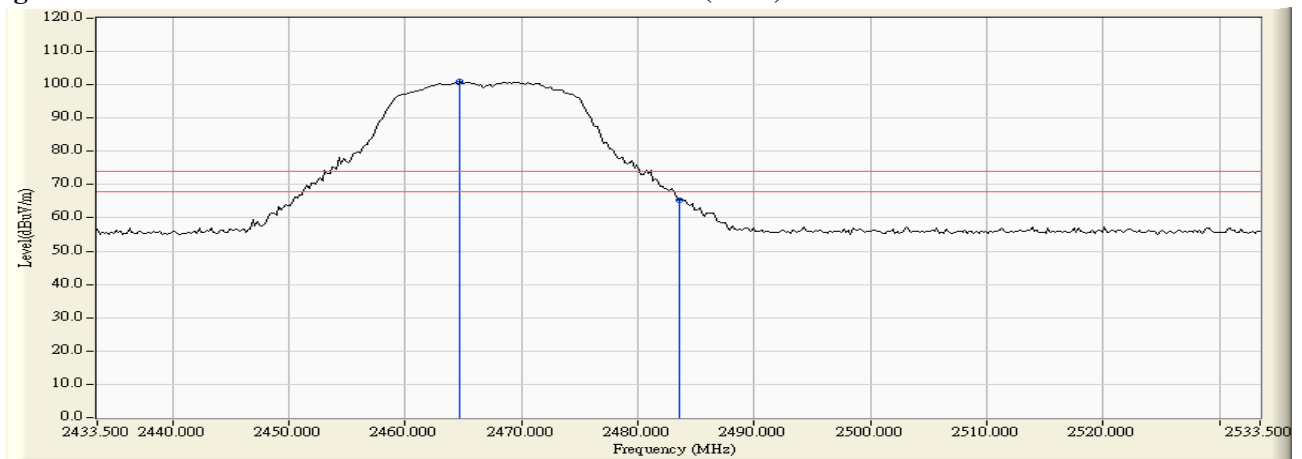

**Figure Channel 12: Vertical (Average)**

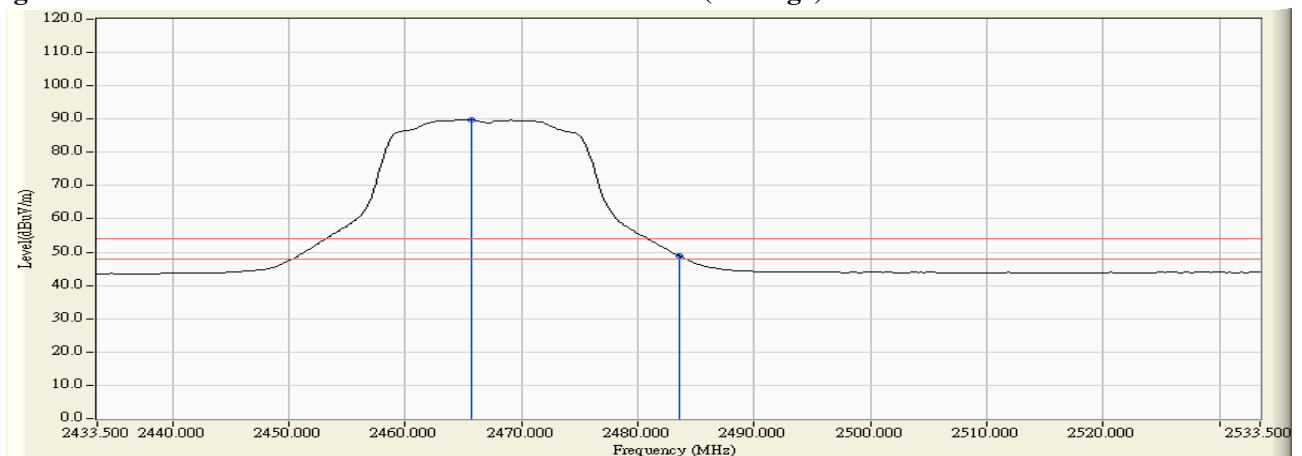

Note:

1. All readings above 1GHz are performed with peak and/or average measurements as necessary.
2. Peak measurements: RBW = 1MHz, VBW = 3 MHz, Sweep: Auto.
3. Average measurements: RBW = 1MHz, VBW = 10 Hz, Sweep: Auto.
4. “ \* ”, means this data is the worst emission level.
5. Measurement Level = Reading Level + Correct Factor.
6. The average measurement was not performed when the peak measured data under the limit of average detection.

Product : Intel® Dual Band Wireless-AC 8260  
 Test Item : Band Edge  
 Test Site : No.3 OATS  
 Test Mode : Mode 1 SISO A: Transmit - 802.11n-20BW\_7.2Mbps(2.4G Band)

**RF Radiated Measurement (Horizontal):**

Channel No.	Frequency (MHz)	Correct Factor (dB)	Reading Level (dBuV)	Emission Level (dBuV/m)	Peak Limit (dBuV/m)	Average Limit (dBuV/m)	Result
01 (Peak)	2389.000	31.505	42.213	73.718	74.00	54.00	Pass
01 (Peak)	2390.000	31.509	40.942	72.451	74.00	54.00	Pass
01 (Peak)	2400.000	31.561	57.964	89.525	74.00	54.00	Pass
01 (Peak)	2414.200	31.655	78.920	110.575	--	--	Pass
01 (Average)	2390.000	31.509	21.828	53.337	74.00	54.00	Pass
01 (Average)	2400.000	31.561	38.378	69.939	74.00	54.00	Pass
01 (Average)	2415.600	31.665	67.960	99.626	--	--	Pass

**Figure Channel 01: Horizontal (Peak)**

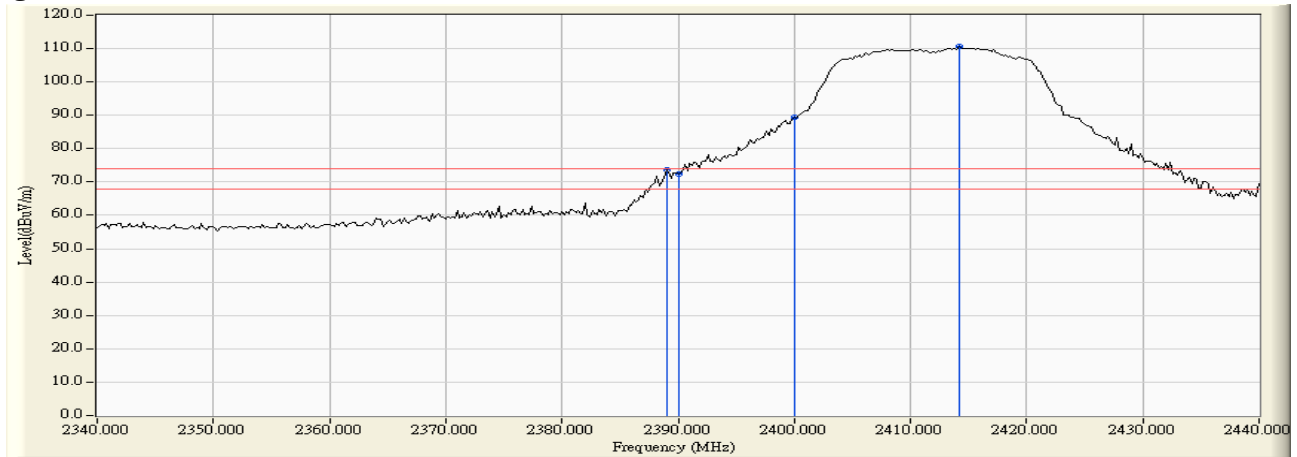

**Figure Channel 01: Horizontal (Average)**

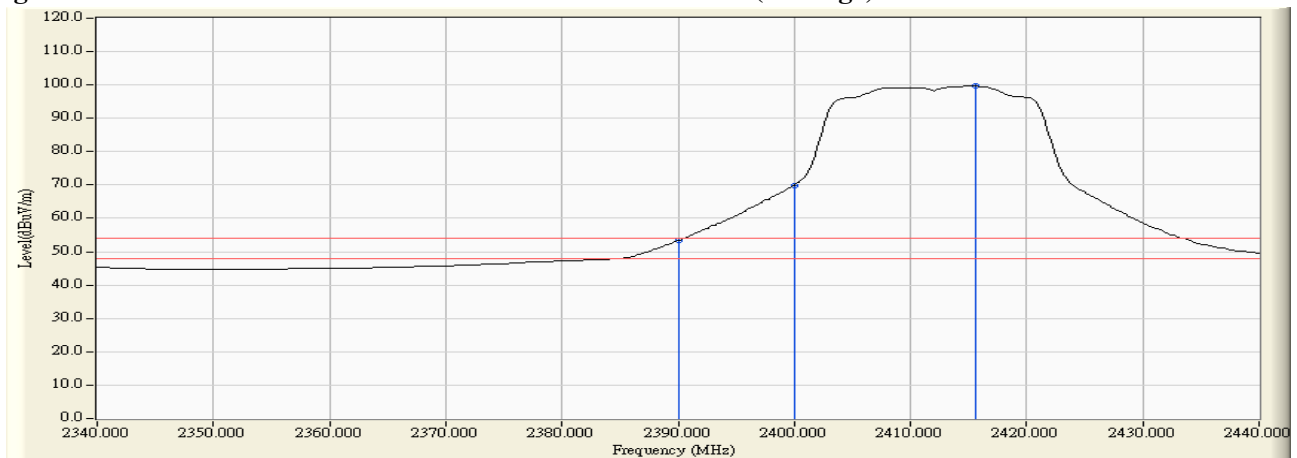

Note:

1. All readings above 1GHz are performed with peak and/or average measurements as necessary.
2. Peak measurements: RBW = 1MHz, VBW = 3 MHz, Sweep: Auto.
3. Average measurements: RBW = 1MHz, VBW = 10 Hz, Sweep: Auto.
4. “ \* ”, means this data is the worst emission level.
5. Measurement Level = Reading Level + Correct Factor.
6. The average measurement was not performed when the peak measured data under the limit of average detection.

Product : Intel® Dual Band Wireless-AC 8260  
 Test Item : Band Edge  
 Test Site : No.3 OATS  
 Test Mode : Mode 1 SISO A: Transmit - 802.11n-20BW\_7.2Mbps(2.4G Band)

**RF Radiated Measurement (Vertical):**

Channel No.	Frequency (MHz)	Correct Factor (dB)	Reading Level (dBuV)	Emission Level (dBuV/m)	Peak Limit (dBuV/m)	Average Limit (dBuV/m)	Result
01 (Peak)	2388.800	30.921	37.979	68.900	74.00	54.00	Pass
01 (Peak)	2390.000	30.915	37.217	68.132	74.00	54.00	Pass
01 (Peak)	2400.000	30.912	53.225	84.137	74.00	54.00	Pass
01 (Peak)	2415.600	30.973	75.085	106.059	--	--	Pass
01 (Average)	2390.000	30.915	19.088	50.003	74.00	54.00	Pass
01 (Average)	2400.000	30.912	35.091	66.003	74.00	54.00	Pass
01 (Average)	2414.800	30.968	64.665	95.633	--	--	Pass

**Figure Channel 01: Vertical (Peak)**

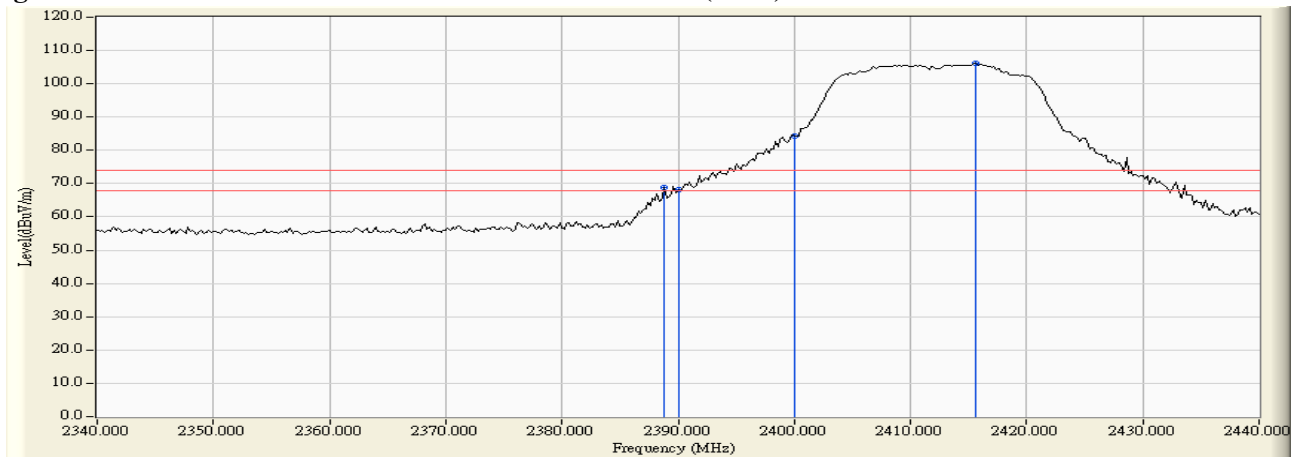

**Figure Channel 01: Vertical (Average)**

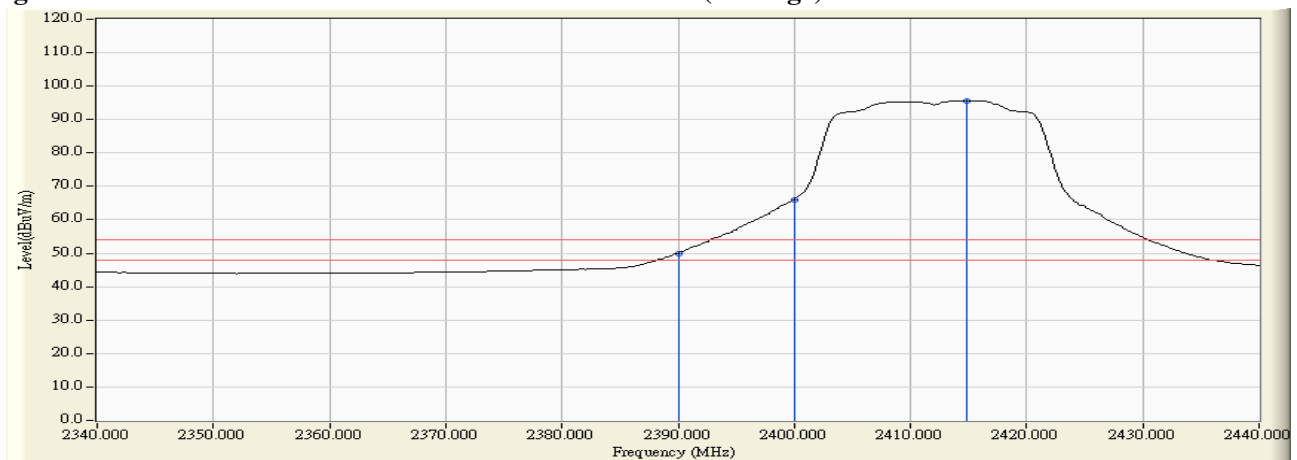

Note:

1. All readings above 1GHz are performed with peak and/or average measurements as necessary.
2. Peak measurements: RBW = 1MHz, VBW = 3 MHz, Sweep: Auto.
3. Average measurements: RBW = 1MHz, VBW = 10 Hz, Sweep: Auto.
4. “ \* ”, means this data is the worst emission level.
5. Measurement Level = Reading Level + Correct Factor.
6. The average measurement was not performed when the peak measured data under the limit of average detection.

Product : Intel® Dual Band Wireless-AC 8260  
 Test Item : Band Edge  
 Test Site : No.3 OATS  
 Test Mode : Mode 1 SISO A: Transmit - 802.11n-20BW\_7.2Mbps(2.4G Band)

**RF Radiated Measurement (Horizontal):**

Channel No.	Frequency (MHz)	Correct Factor (dB)	Reading Level (dBUV)	Emission Level (dBUV/m)	Peak Limit (dBUV/m)	Average Limit (dBUV/m)	Result
02 (Peak)	2390.000	31.509	35.204	66.713	74.00	54.00	Pass
02 (Peak)	2400.000	31.561	51.235	82.796	74.00	54.00	Pass
02 (Peak)	2414.200	31.655	79.952	111.607	--	--	Pass
02 (Average)	2390.000	31.509	20.883	52.392	74.00	54.00	Pass
02 (Average)	2400.000	31.561	34.898	66.459	74.00	54.00	Pass
02 (Average)	2420.400	31.702	68.997	100.700	--	--	Pass

**Figure Channel 02: Horizontal (Peak)**

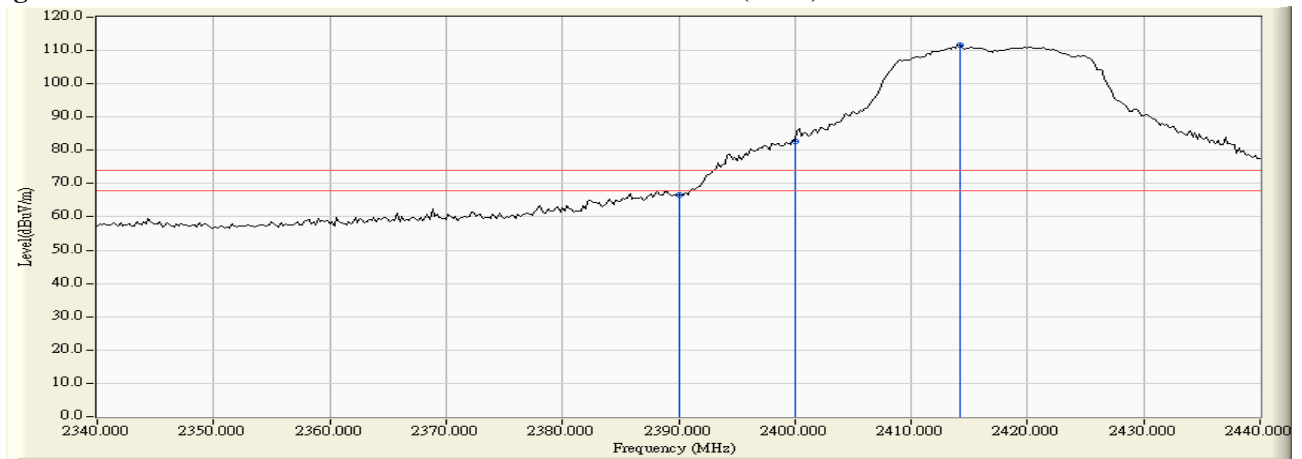

**Figure Channel 02: Horizontal (Average)**

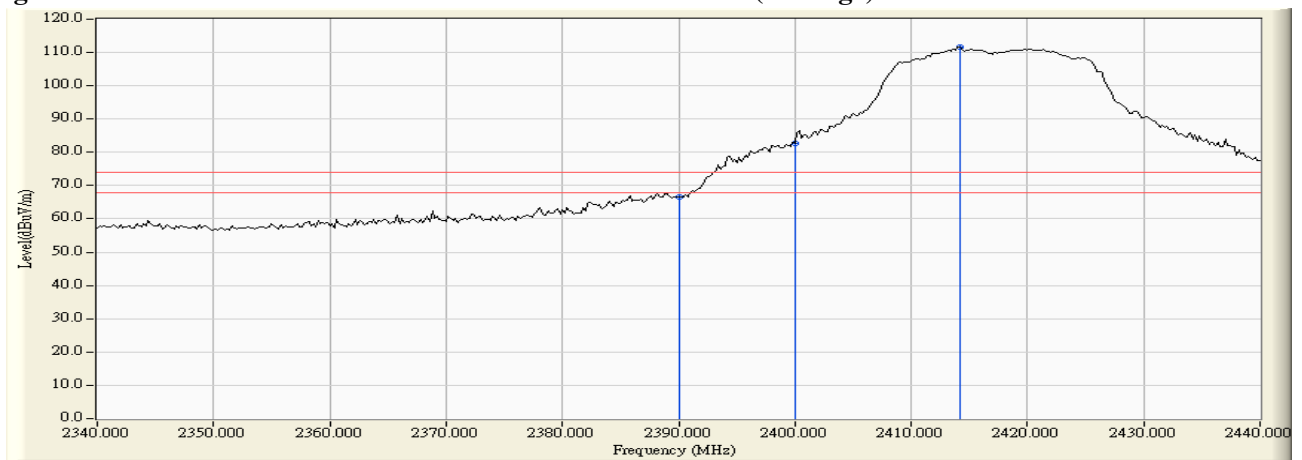

Note:

1. All readings above 1GHz are performed with peak and/or average measurements as necessary.
2. Peak measurements: RBW = 1MHz, VBW = 3 MHz, Sweep: Auto.
3. Average measurements: RBW = 1MHz, VBW = 10 Hz, Sweep: Auto.
4. “ \* ”, means this data is the worst emission level.
5. Measurement Level = Reading Level + Correct Factor.
6. The average measurement was not performed when the peak measured data under the limit of average detection.



Product : Intel® Dual Band Wireless-AC 8260  
 Test Item : Band Edge  
 Test Site : No.3 OATS  
 Test Mode : Mode 1 SISO A: Transmit - 802.11n-20BW\_7.2Mbps(2.4G Band)

**RF Radiated Measurement (Vertical):**

Channel No.	Frequency (MHz)	Correct Factor (dB)	Reading Level (dBuV)	Emission Level (dBuV/m)	Peak Limit (dBuV/m)	Average Limit (dBuV/m)	Result
02 (Peak)	2390.000	30.915	34.906	65.821	74.00	54.00	Pass
02 (Peak)	2400.000	30.912	49.743	80.655	74.00	54.00	Pass
02 (Peak)	2413.200	30.957	76.415	107.372	--	--	Pass
02 (Average)	2390.000	30.915	19.472	50.387	74.00	54.00	Pass
02 (Average)	2400.000	30.912	32.949	63.861	74.00	54.00	Pass
02 (Average)	2414.800	30.968	65.877	96.845	--	--	Pass

**Figure Channel 02: Vertical (Peak)**

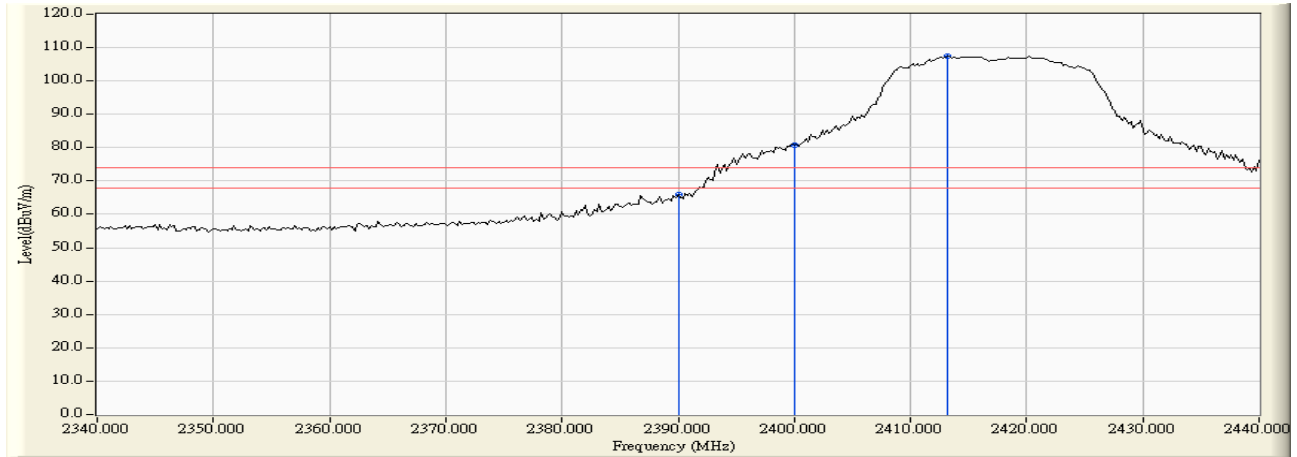

**Figure Channel 02: Vertical (Average)**

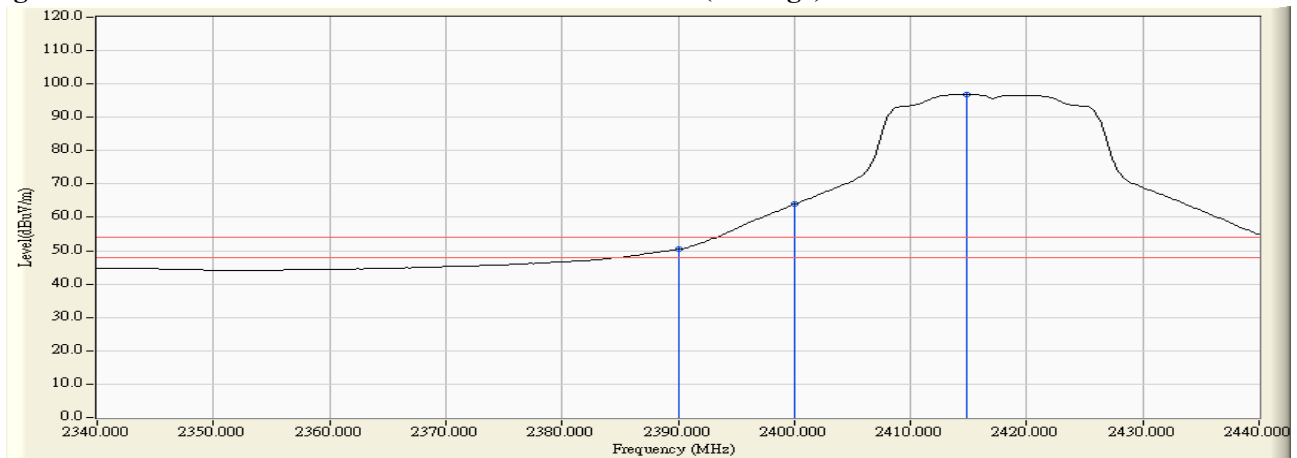

Note:

1. All readings above 1GHz are performed with peak and/or average measurements as necessary.
2. Peak measurements: RBW = 1MHz, VBW = 3 MHz, Sweep: Auto.
3. Average measurements: RBW = 1MHz, VBW = 10 Hz, Sweep: Auto.
4. “ \* ”, means this data is the worst emission level.
5. Measurement Level = Reading Level + Correct Factor.
6. The average measurement was not performed when the peak measured data under the limit of average detection.

Product : Intel® Dual Band Wireless-AC 8260  
 Test Item : Band Edge  
 Test Site : No.3 OATS  
 Test Mode : Mode 1 SISO A: Transmit - 802.11n-20BW\_7.2Mbps(2.4G Band)

**RF Radiated Measurement (Horizontal):**

Channel No.	Frequency (MHz)	Correct Factor (dB)	Reading Level (dBuV)	Emission Level (dBuV/m)	Peak Limit (dBuV/m)	Average Limit (dBuV/m)	Result
10 (Peak)	2454.100	31.959	78.954	110.914	--	--	Pass
10 (Peak)	2483.500	32.182	36.611	68.793	74.00	54.00	Pass
10 (Average)	2454.500	31.962	67.776	99.739	--	--	Pass
10 (Average)	2483.500	32.182	21.495	53.677	74.00	54.00	Pass

**Figure Channel 10: Horizontal (Peak)**

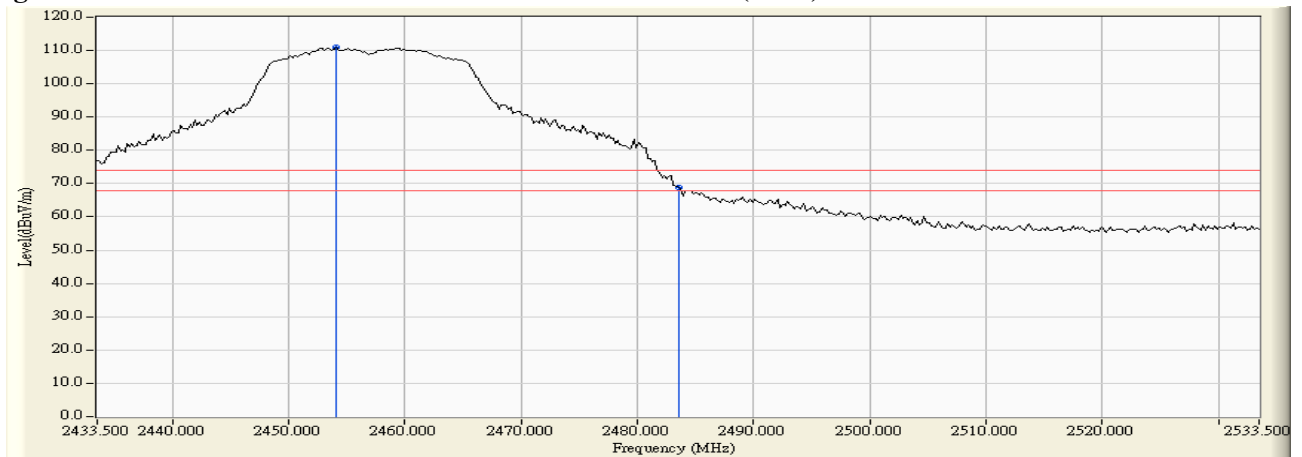

**Figure Channel 10: Horizontal (Average)**

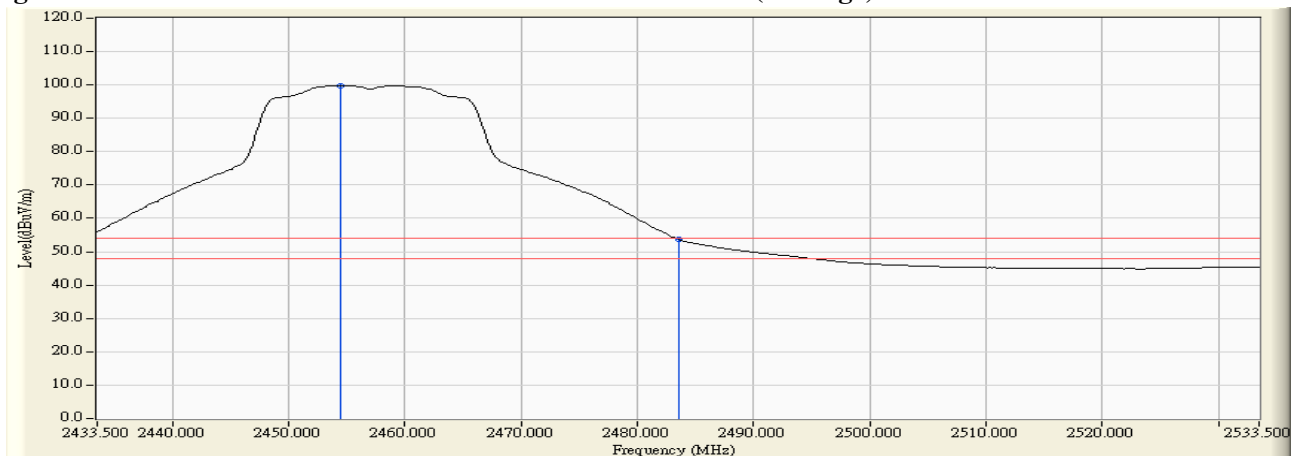

Note:

1. All readings above 1GHz are performed with peak and/or average measurements as necessary.
2. Peak measurements: RBW = 1MHz, VBW = 3 MHz, Sweep: Auto.
3. Average measurements: RBW = 1MHz, VBW = 10 Hz, Sweep: Auto.
4. “ \* ”, means this data is the worst emission level.
5. Measurement Level = Reading Level + Correct Factor.
6. The average measurement was not performed when the peak measured data under the limit of average detection.

Product : Intel® Dual Band Wireless-AC 8260  
 Test Item : Band Edge  
 Test Site : No.3 OATS  
 Test Mode : Mode 1 SISO A: Transmit - 802.11n-20BW\_7.2Mbps(2.4G Band)

**RF Radiated Measurement (Vertical):**

Channel No.	Frequency (MHz)	Correct Factor (dB)	Reading Level (dBuV)	Emission Level (dBuV/m)	Peak Limit (dBuV/m)	Average Limit (dBuV/m)	Result
10 (Peak)	2455.100	31.243	75.484	106.727	--	--	Pass
10 (Peak)	2483.500	31.435	32.970	64.405	74.00	54.00	Pass
10 (Average)	2453.900	31.235	64.810	96.045	--	--	Pass
10 (Average)	2483.500	31.435	19.016	50.451	74.00	54.00	Pass

**Figure Channel 10: Vertical (Peak)**

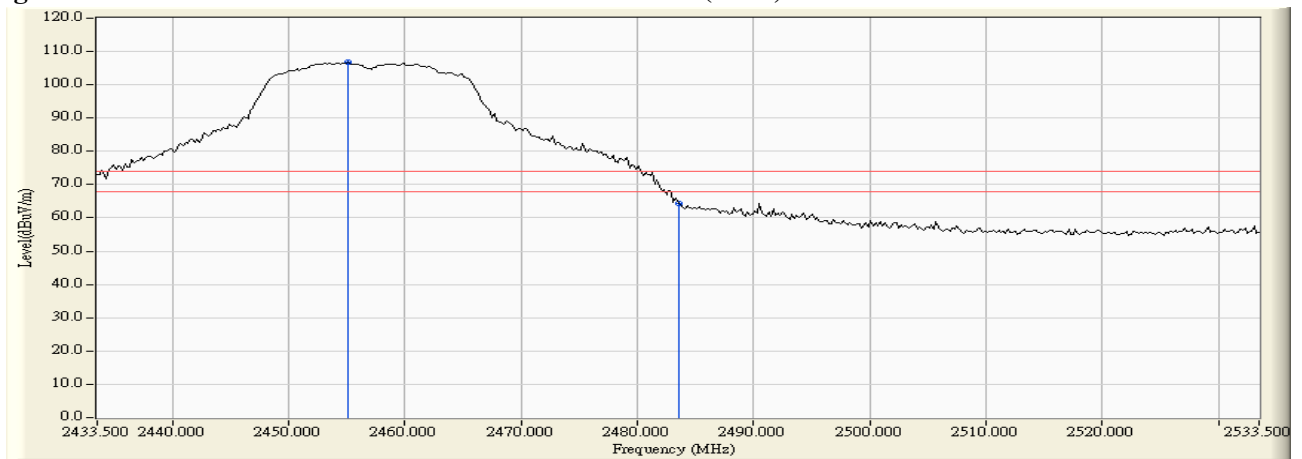

**Figure Channel 10: Vertical (Average)**

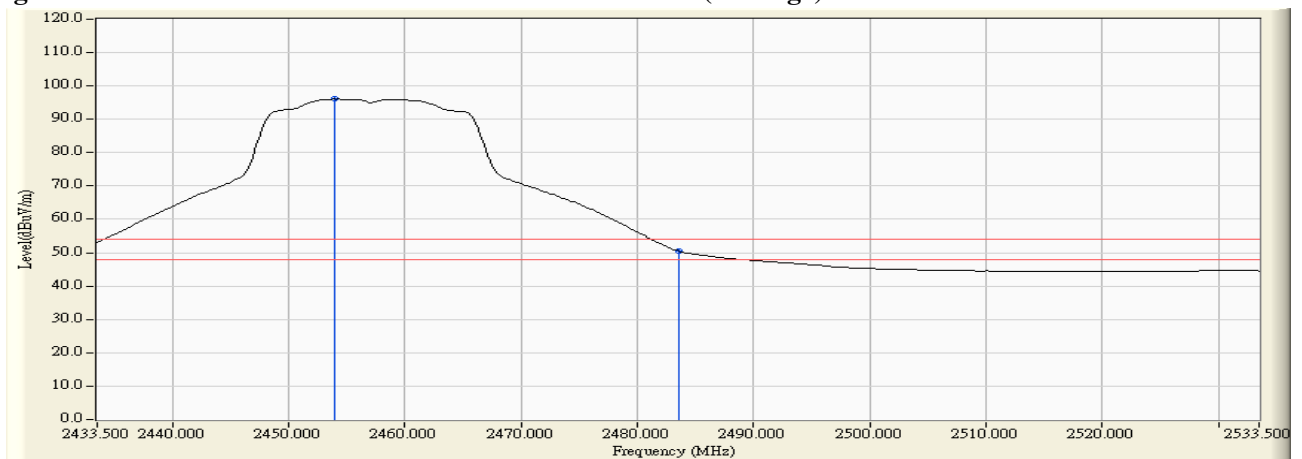

Note:

1. All readings above 1GHz are performed with peak and/or average measurements as necessary.
2. Peak measurements: RBW = 1MHz, VBW = 3 MHz, Sweep: Auto.
3. Average measurements: RBW = 1MHz, VBW = 10 Hz, Sweep: Auto.
4. “ \* ”, means this data is the worst emission level.
5. Measurement Level = Reading Level + Correct Factor.
6. The average measurement was not performed when the peak measured data under the limit of average detection.

Product : Intel® Dual Band Wireless-AC 8260  
 Test Item : Band Edge  
 Test Site : No.3 OATS  
 Test Mode : Mode 1 SISO A: Transmit - 802.11n-20BW\_7.2Mbps(2.4G Band)

**RF Radiated Measurement (Horizontal):**

Channel No.	Frequency (MHz)	Correct Factor (dB)	Reading Level (dBuV)	Emission Level (dBuV/m)	Peak Limit (dBuV/m)	Average Limit (dBuV/m)	Result
11 (Peak)	2464.100	32.036	76.716	108.751	--	--	Pass
11 (Peak)	2483.500	32.182	38.455	70.637	74.00	54.00	Pass
11 (Peak)	2483.900	32.185	39.958	72.143	74.00	54.00	Pass
11 (Average)	2459.100	31.998	65.431	97.428	--	--	Pass
11 (Average)	2483.500	32.182	21.484	53.666	74.00	54.00	Pass

**Figure Channel 11: Horizontal (Peak)**

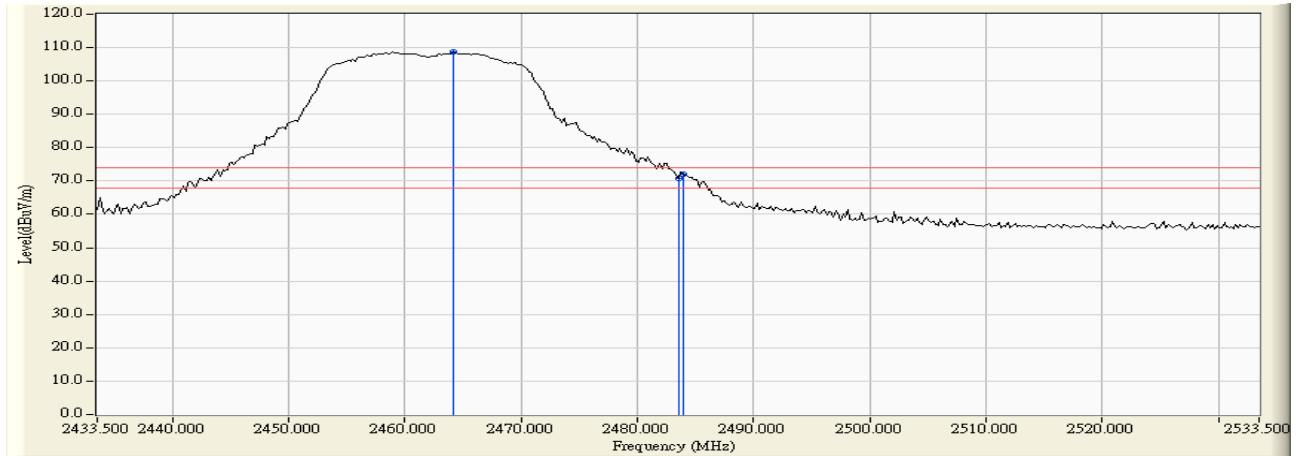

**Figure Channel 11: Horizontal (Average)**

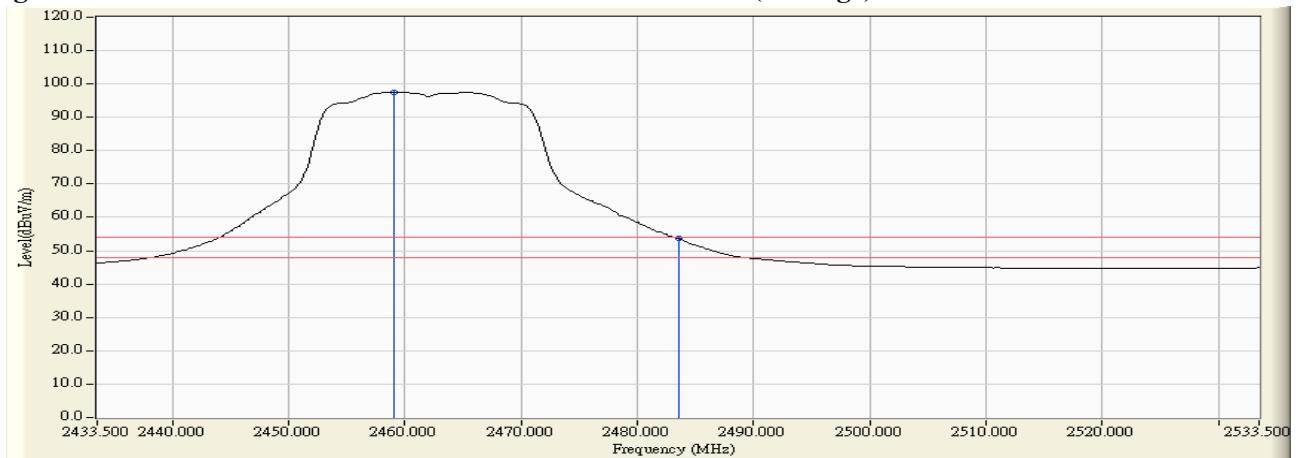

Note:

1. All readings above 1GHz are performed with peak and/or average measurements as necessary.
2. Peak measurements: RBW = 1MHz, VBW = 3 MHz, Sweep: Auto.
3. Average measurements: RBW = 1MHz, VBW = 10 Hz, Sweep: Auto.
4. “ \* ”, means this data is the worst emission level.
5. Measurement Level = Reading Level + Correct Factor.
6. The average measurement was not performed when the peak measured data under the limit of average detection.



Product : Intel® Dual Band Wireless-AC 8260  
 Test Item : Band Edge  
 Test Site : No.3 OATS  
 Test Mode : Mode 1 SISO A: Transmit - 802.11n-20BW\_7.2Mbps(2.4G Band)

**RF Radiated Measurement (Vertical):**

Channel No.	Frequency (MHz)	Correct Factor (dB)	Reading Level (dBuV)	Emission Level (dBuV/m)	Peak Limit (dBuV/m)	Average Limit (dBuV/m)	Result
11 (Peak)	2459.100	31.271	73.055	104.326	--	--	Pass
11 (Peak)	2483.500	31.435	34.168	65.603	74.00	54.00	Pass
11 (Average)	2458.900	31.270	62.587	93.856	--	--	Pass
11 (Average)	2483.500	31.435	18.435	49.870	74.00	54.00	Pass

**Figure Channel 11: Vertical (Peak)**

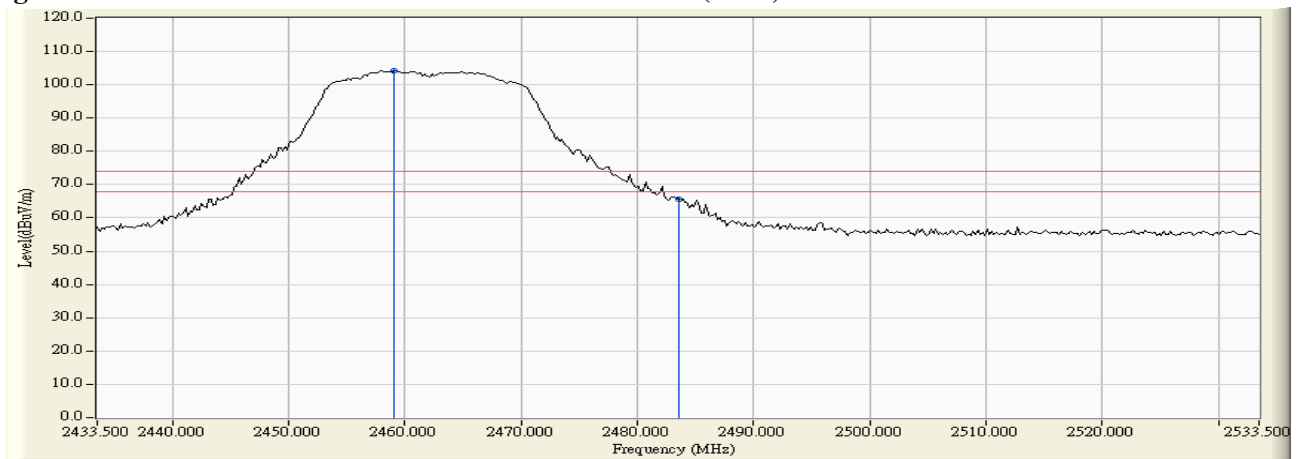

**Figure Channel 11: Vertical (Average)**

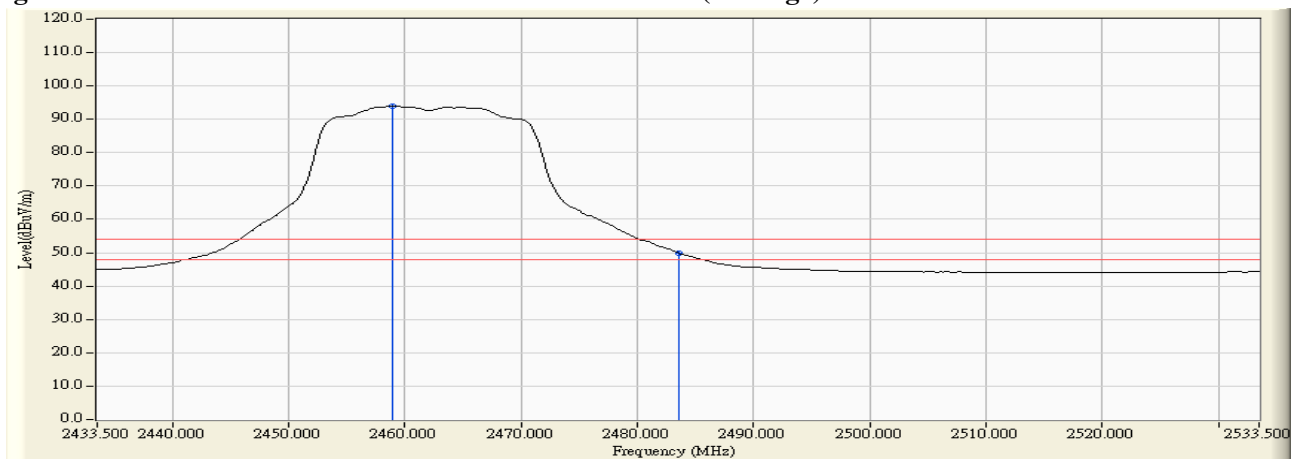

Note:

1. All readings above 1GHz are performed with peak and/or average measurements as necessary.
2. Peak measurements: RBW = 1MHz, VBW = 3 MHz, Sweep: Auto.
3. Average measurements: RBW = 1MHz, VBW = 10 Hz, Sweep: Auto.
4. “ \* ”, means this data is the worst emission level.
5. Measurement Level = Reading Level + Correct Factor.
6. The average measurement was not performed when the peak measured data under the limit of average detection.

Product : Intel® Dual Band Wireless-AC 8260  
 Test Item : Band Edge  
 Test Site : No.3 OATS  
 Test Mode : Mode 1 SISO A: Transmit - 802.11n-20BW\_7.2Mbps(2.4G Band)

**RF Radiated Measurement (Horizontal):**

Channel No.	Frequency (MHz)	Correct Factor (dB)	Reading Level (dBuV)	Emission Level (dBuV/m)	Peak Limit (dBuV/m)	Average Limit (dBuV/m)	Result
12 (Peak)	2462.700	32.025	72.974	104.999	--	--	Pass
12 (Peak)	2483.500	32.182	39.055	71.237	74.00	54.00	Pass
12 (Average)	2463.900	32.033	62.242	94.276	--	--	Pass
12 (Average)	2483.500	32.182	21.734	53.916	74.00	54.00	Pass

**Figure Channel 12: Horizontal (Peak)**

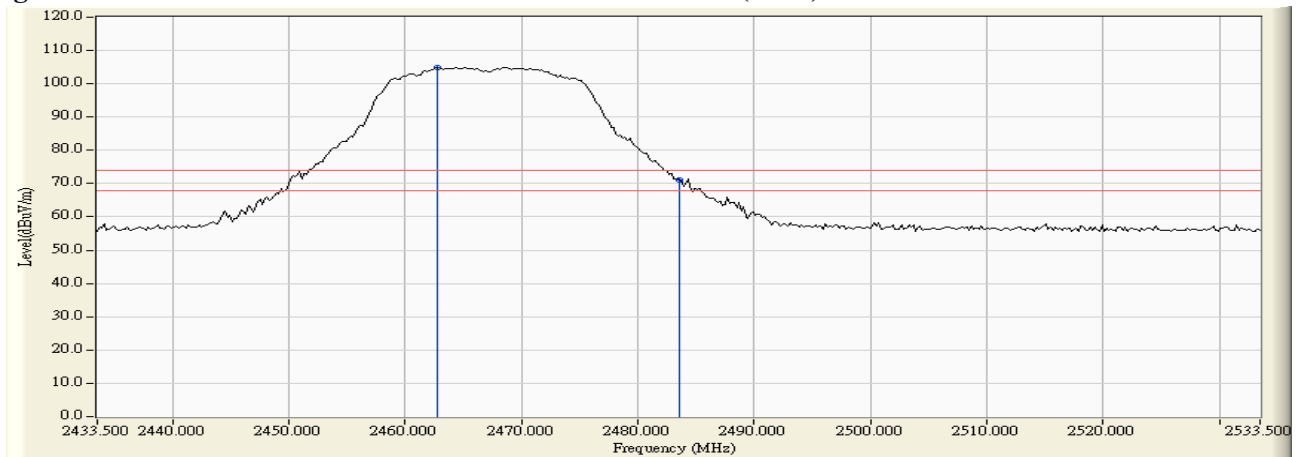

**Figure Channel 12: Horizontal (Average)**

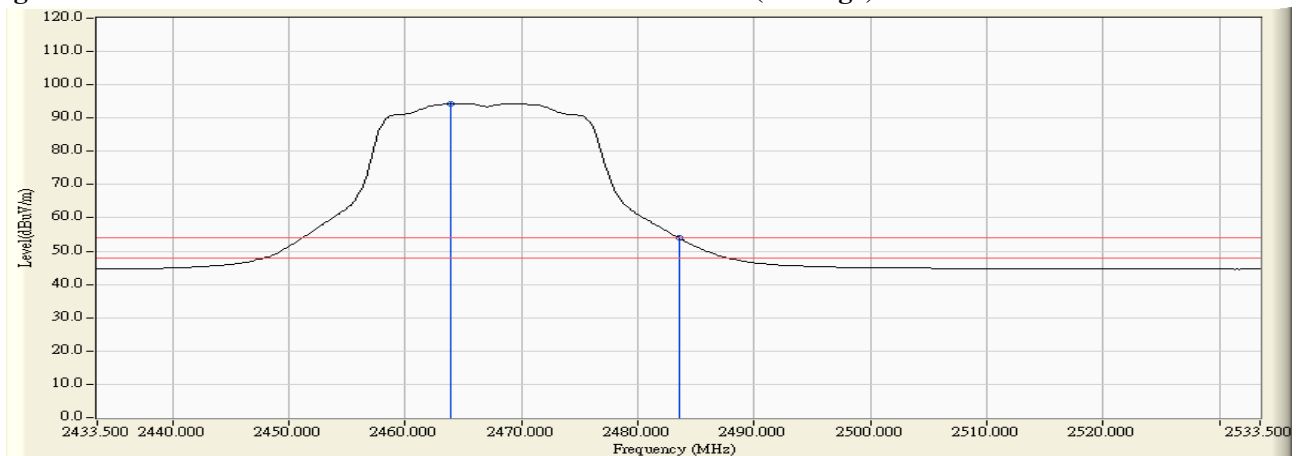

Note:

1. All readings above 1GHz are performed with peak and/or average measurements as necessary.
2. Peak measurements: RBW = 1MHz, VBW = 3 MHz, Sweep: Auto.
3. Average measurements: RBW = 1MHz, VBW = 10 Hz, Sweep: Auto.
4. “ \* ”, means this data is the worst emission level.
5. Measurement Level = Reading Level + Correct Factor.
6. The average measurement was not performed when the peak measured data under the limit of average detection.

Product : Intel® Dual Band Wireless-AC 8260  
 Test Item : Band Edge  
 Test Site : No.3 OATS  
 Test Mode : Mode 1 SISO A: Transmit - 802.11n-20BW\_7.2Mbps(2.4G Band)

**RF Radiated Measurement (Vertical):**

Channel No.	Frequency (MHz)	Correct Factor (dB)	Reading Level (dBuV)	Emission Level (dBuV/m)	Peak Limit (dBuV/m)	Average Limit (dBuV/m)	Result
12 (Peak)	2463.900	31.303	70.301	101.604	--	--	Pass
12 (Peak)	2483.500	31.435	35.390	66.825	74.00	54.00	Pass
12 (Average)	2464.700	31.308	58.959	90.268	--	--	Pass
12 (Average)	2483.500	31.435	18.976	50.411	74.00	54.00	Pass

**Figure Channel 12: Vertical (Peak)**

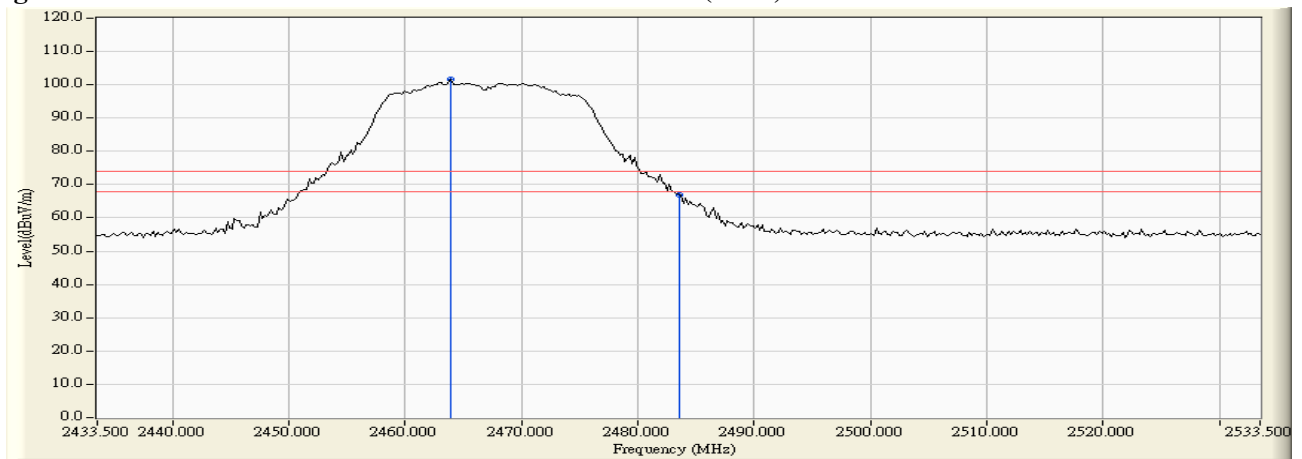

**Figure Channel 12: Vertical (Average)**

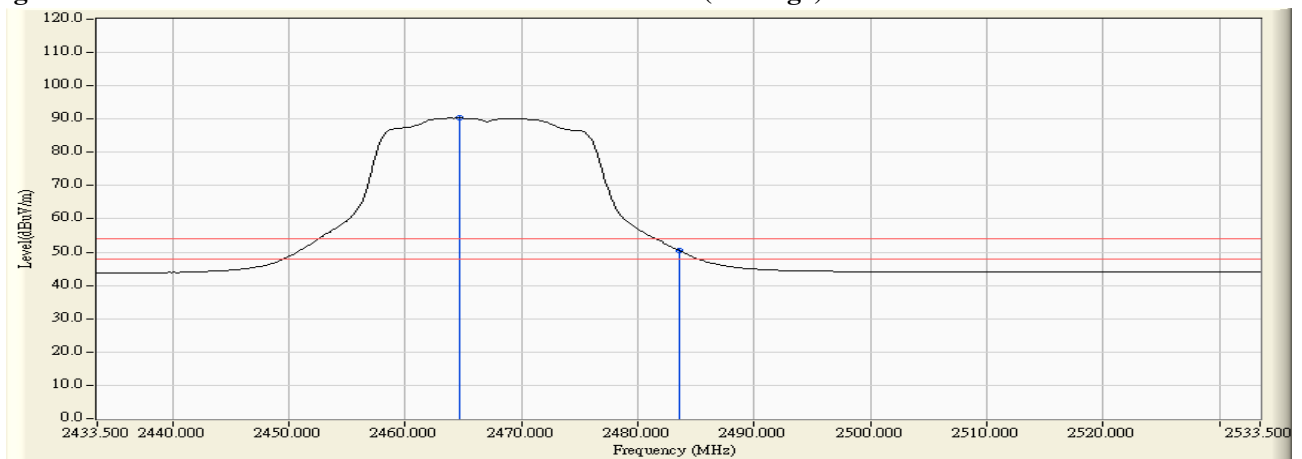

Note:

1. All readings above 1GHz are performed with peak and/or average measurements as necessary.
2. Peak measurements: RBW = 1MHz, VBW = 3 MHz, Sweep: Auto.
3. Average measurements: RBW = 1MHz, VBW = 10 Hz, Sweep: Auto.
4. “ \* ”, means this data is the worst emission level.
5. Measurement Level = Reading Level + Correct Factor.
6. The average measurement was not performed when the peak measured data under the limit of average detection.

Product : Intel® Dual Band Wireless-AC 8260  
 Test Item : Band Edge  
 Test Site : No.3 OATS  
 Test Mode : Mode 1 SISO A: Transmit - 802.11n-40BW\_15Mbps(2.4G Band)

**RF Radiated Measurement (Horizontal):**

Channel No.	Frequency (MHz)	Correct Factor (dB)	Reading Level (dBuV)	Emission Level (dBuV/m)	Peak Limit (dBuV/m)	Average Limit (dBuV/m)	Result
03 (Peak)	2388.200	31.502	36.588	68.090	74.00	54.00	Pass
03 (Peak)	2390.000	31.509	34.939	66.448	74.00	54.00	Pass
03 (Peak)	2400.000	31.561	49.286	80.847	74.00	54.00	Pass
03 (Peak)	2432.200	31.792	72.955	104.748	--	--	Pass
03 (Average)	2390.000	31.509	22.100	53.609	74.00	54.00	Pass
03 (Average)	2400.000	31.561	35.565	67.126	74.00	54.00	Pass
03 (Average)	2433.200	31.801	61.324	93.124	--	--	Pass

**Figure Channel 03: Horizontal (Peak)**

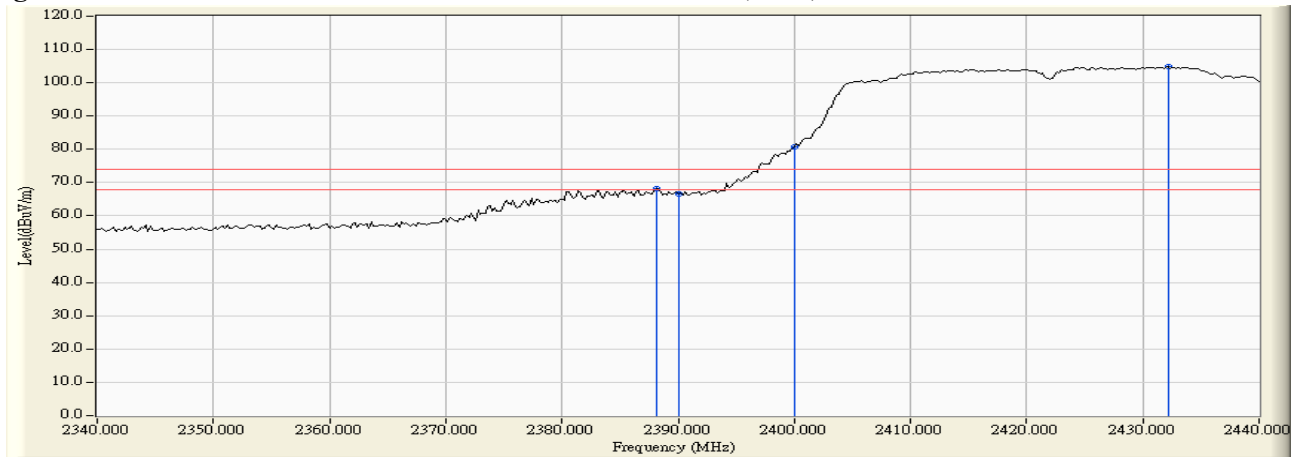

**Figure Channel 03: Horizontal (Average)**

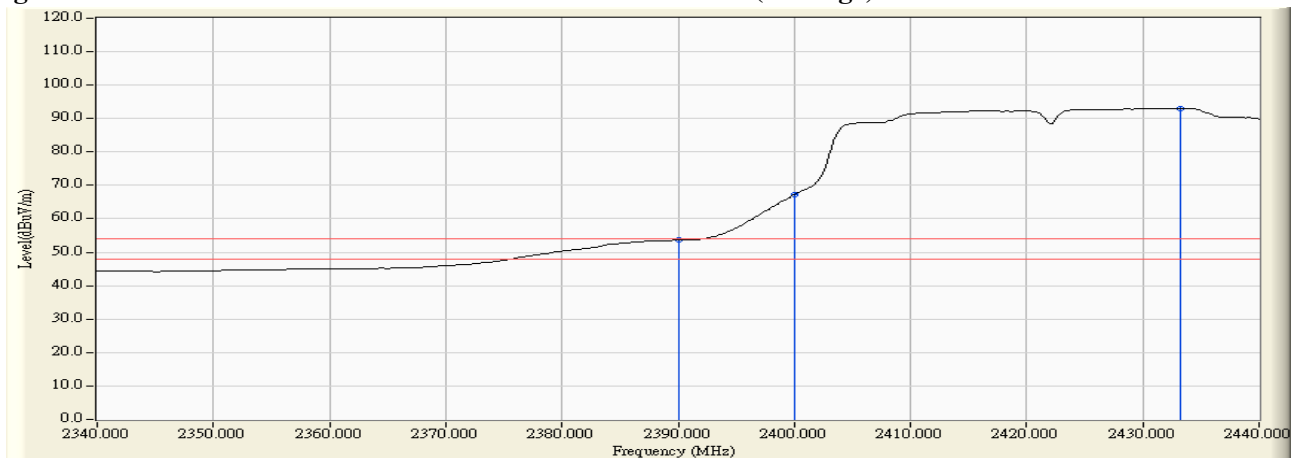

Note:

1. All readings above 1GHz are performed with peak and/or average measurements as necessary.
2. Peak measurements: RBW = 1MHz, VBW = 3 MHz, Sweep: Auto.
3. Average measurements: RBW = 1MHz, VBW = 10 Hz, Sweep: Auto.
4. “ \* ”, means this data is the worst emission level.
5. Measurement Level = Reading Level + Correct Factor.
6. The average measurement was not performed when the peak measured data under the limit of average detection.



Product : Intel® Dual Band Wireless-AC 8260  
 Test Item : Band Edge  
 Test Site : No.3 OATS  
 Test Mode : Mode 1 SISO A: Transmit - 802.11n-40BW\_15Mbps(2.4G Band)

**RF Radiated Measurement (Vertical):**

Channel No.	Frequency (MHz)	Correct Factor (dB)	Reading Level (dBuV)	Emission Level (dBuV/m)	Peak Limit (dBuV/m)	Average Limit (dBuV/m)	Result
03 (Peak)	2381.400	30.955	31.273	62.228	74.00	54.00	Pass
03 (Peak)	2390.000	30.915	29.592	60.507	74.00	54.00	Pass
03 (Peak)	2400.000	30.912	44.126	75.038	74.00	54.00	Pass
03 (Peak)	2432.200	31.086	69.071	100.157	--	--	Pass
03 (Average)	2390.000	30.915	16.976	47.891	74.00	54.00	Pass
03 (Average)	2400.000	30.912	30.155	61.067	74.00	54.00	Pass
03 (Average)	2433.400	31.094	57.491	88.586	--	--	Pass

**Figure Channel 03: Vertical (Peak)**

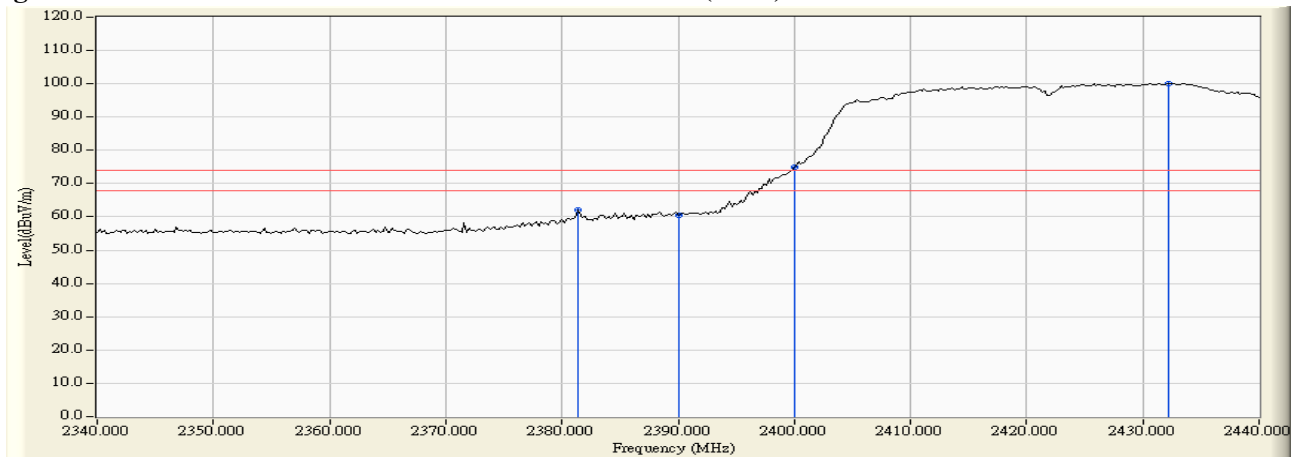

**Figure Channel 03: Vertical (Average)**

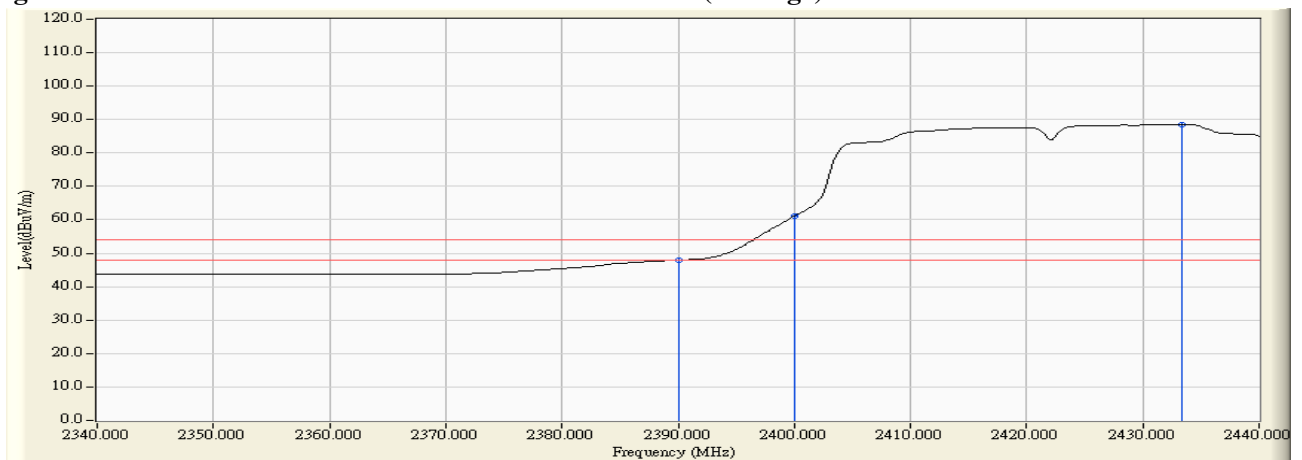

Note:

1. All readings above 1GHz are performed with peak and/or average measurements as necessary.
2. Peak measurements: RBW = 1MHz, VBW = 3 MHz, Sweep: Auto.
3. Average measurements: RBW = 1MHz, VBW = 10 Hz, Sweep: Auto.
4. “ \* ”, means this data is the worst emission level.
5. Measurement Level = Reading Level + Correct Factor.
6. The average measurement was not performed when the peak measured data under the limit of average detection.

Product : Intel® Dual Band Wireless-AC 8260  
 Test Item : Band Edge  
 Test Site : No.3 OATS  
 Test Mode : Mode 1 SISO A: Transmit - 802.11n-40BW\_15Mbps(2.4G Band)

**RF Radiated Measurement (Horizontal):**

Channel No.	Frequency (MHz)	Correct Factor (dB)	Reading Level (dBuV)	Emission Level (dBuV/m)	Peak Limit (dBuV/m)	Average Limit (dBuV/m)	Result
04 (Peak)	2386.800	31.497	36.401	67.898	74.00	54.00	Pass
04 (Peak)	2390.000	31.509	35.077	66.586	74.00	54.00	Pass
04 (Peak)	2400.000	31.561	38.139	69.700	74.00	54.00	Pass
04 (Peak)	2435.600	31.819	74.457	106.276	--	--	Pass
04 (Average)	2390.000	31.509	21.621	53.130	74.00	54.00	Pass
04 (Average)	2400.000	31.561	25.817	57.378	74.00	54.00	Pass
04 (Average)	2438.600	31.842	62.651	94.493	--	--	Pass

**Figure Channel 04:**

**Horizontal (Peak)**

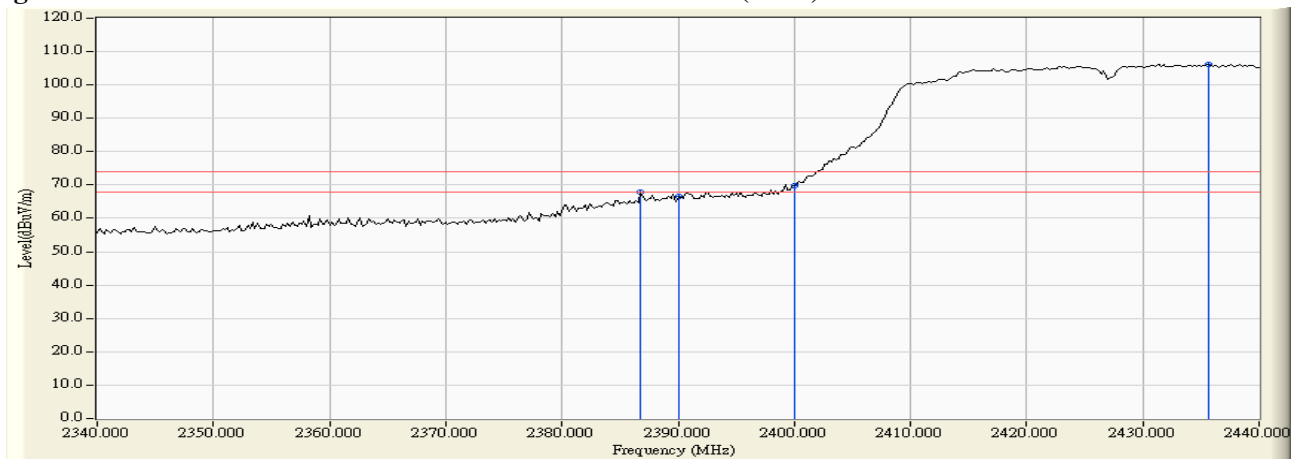

**Figure Channel 04:**

**Horizontal (Average)**

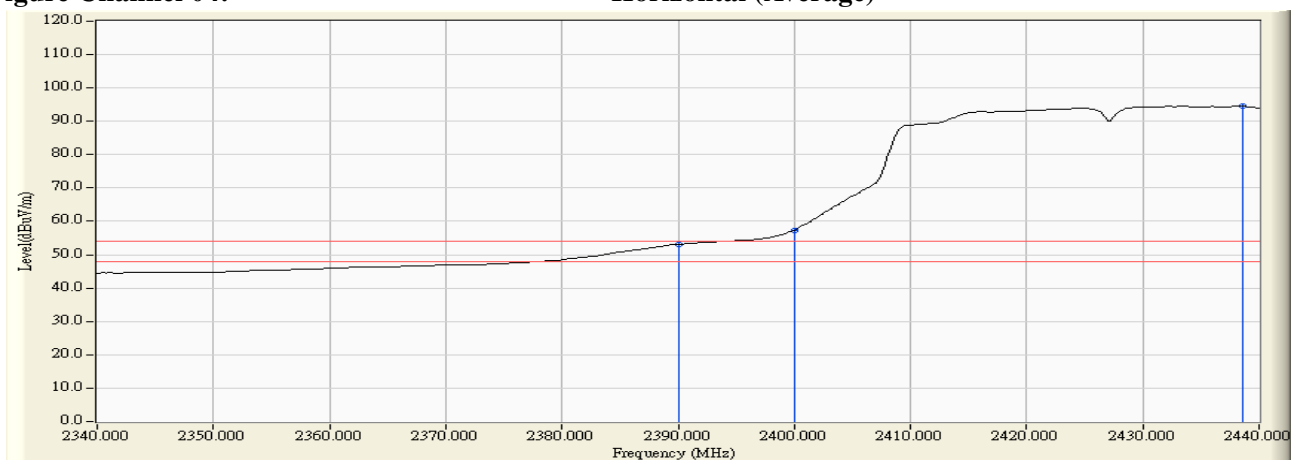

Note:

1. All readings above 1GHz are performed with peak and/or average measurements as necessary.
2. Peak measurements: RBW = 1MHz, VBW = 3 MHz, Sweep: Auto.
3. Average measurements: RBW = 1MHz, VBW = 10 Hz, Sweep: Auto.
4. “ \* ”, means this data is the worst emission level.
5. Measurement Level = Reading Level + Correct Factor.
6. The average measurement was not performed when the peak measured data under the limit of average detection.

Product : Intel® Dual Band Wireless-AC 8260  
 Test Item : Band Edge  
 Test Site : No.3 OATS  
 Test Mode : Mode 1 SISO A: Transmit - 802.11n-40BW\_15Mbps(2.4G Band)

**RF Radiated Measurement (Vertical):**

Channel No.	Frequency (MHz)	Correct Factor (dB)	Reading Level (dBuV)	Emission Level (dBuV/m)	Peak Limit (dBuV/m)	Average Limit (dBuV/m)	Result
04 (Peak)	2389.600	30.917	33.475	64.392	74.00	54.00	Pass
04 (Peak)	2390.000	30.915	31.940	62.855	74.00	54.00	Pass
04 (Peak)	2400.000	30.912	35.163	66.075	74.00	54.00	Pass
04 (Peak)	2432.600	31.089	70.753	101.842	--	--	Pass
04 (Average)	2390.000	30.915	17.935	48.850	74.00	54.00	Pass
04 (Average)	2400.000	30.912	22.129	53.041	74.00	54.00	Pass
04 (Average)	2438.400	31.129	59.348	90.476	--	--	Pass

**Figure Channel 04: Vertical (Peak)**

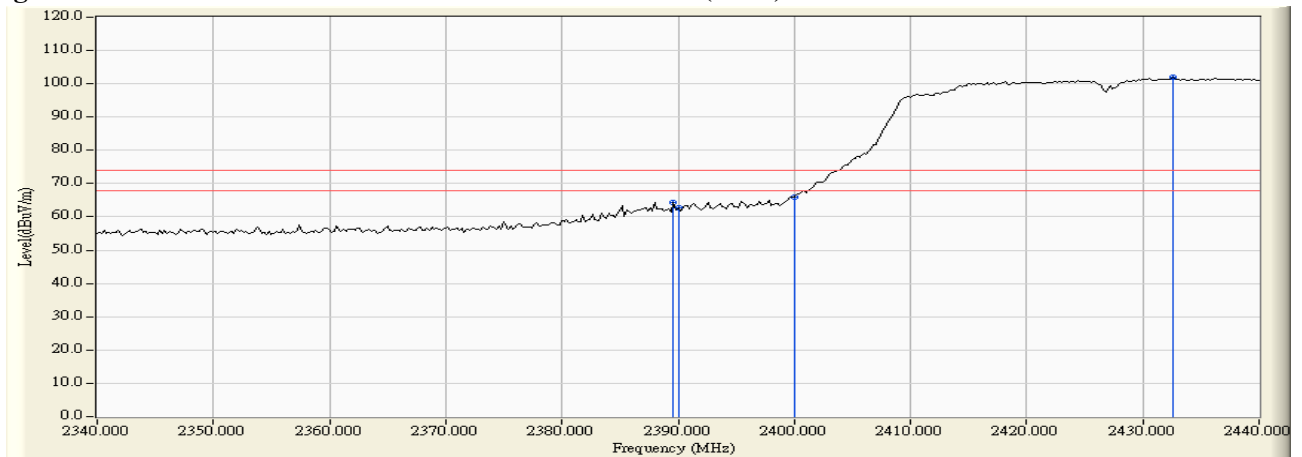

**Figure Channel 04: Vertical (Average)**

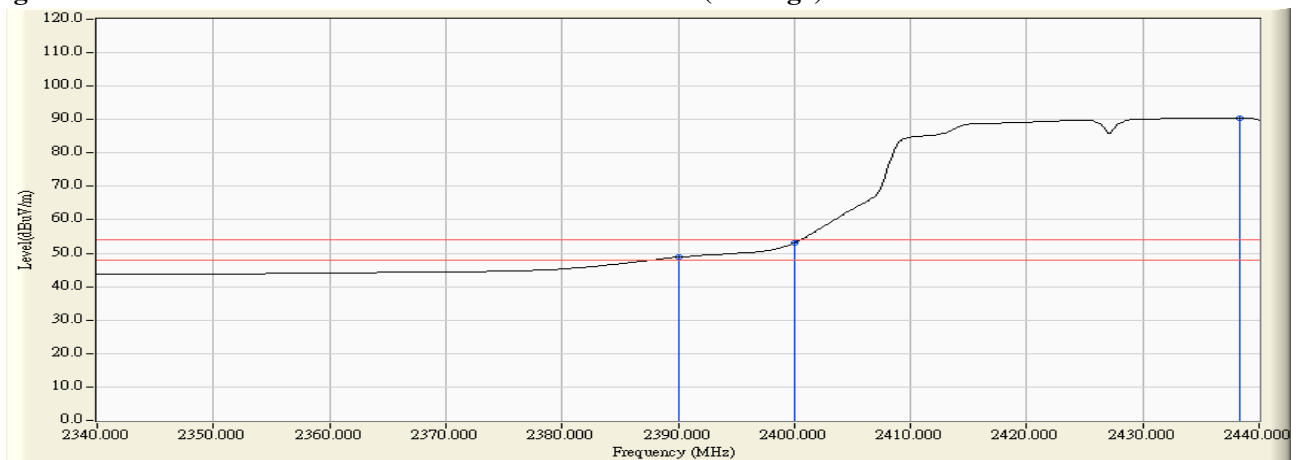

Note:

1. All readings above 1GHz are performed with peak and/or average measurements as necessary.
2. Peak measurements: RBW = 1MHz, VBW = 3 MHz, Sweep: Auto.
3. Average measurements: RBW = 1MHz, VBW = 10 Hz, Sweep: Auto.
4. “ \* ”, means this data is the worst emission level.
5. Measurement Level = Reading Level + Correct Factor.
6. The average measurement was not performed when the peak measured data under the limit of average detection.

Product : Intel® Dual Band Wireless-AC 8260  
 Test Item : Band Edge  
 Test Site : No.3 OATS  
 Test Mode : Mode 1 SISO A: Transmit - 802.11n-40BW\_15Mbps(2.4G Band)

**RF Radiated Measurement (Horizontal):**

Channel No.	Frequency (MHz)	Correct Factor (dB)	Reading Level (dBuV)	Emission Level (dBuV/m)	Peak Limit (dBuV/m)	Average Limit (dBuV/m)	Result
07 (Peak)	2450.300	31.931	72.899	104.830	--	--	Pass
07 (Peak)	2483.500	32.182	35.438	67.620	74.00	54.00	Pass
07 (Peak)	2484.900	32.193	37.057	69.250	74.00	54.00	Pass
07 (Average)	2453.300	31.953	61.095	93.048	--	--	Pass
07 (Average)	2483.500	32.182	21.402	53.584	74.00	54.00	Pass

**Figure Channel 07: Horizontal (Peak)**

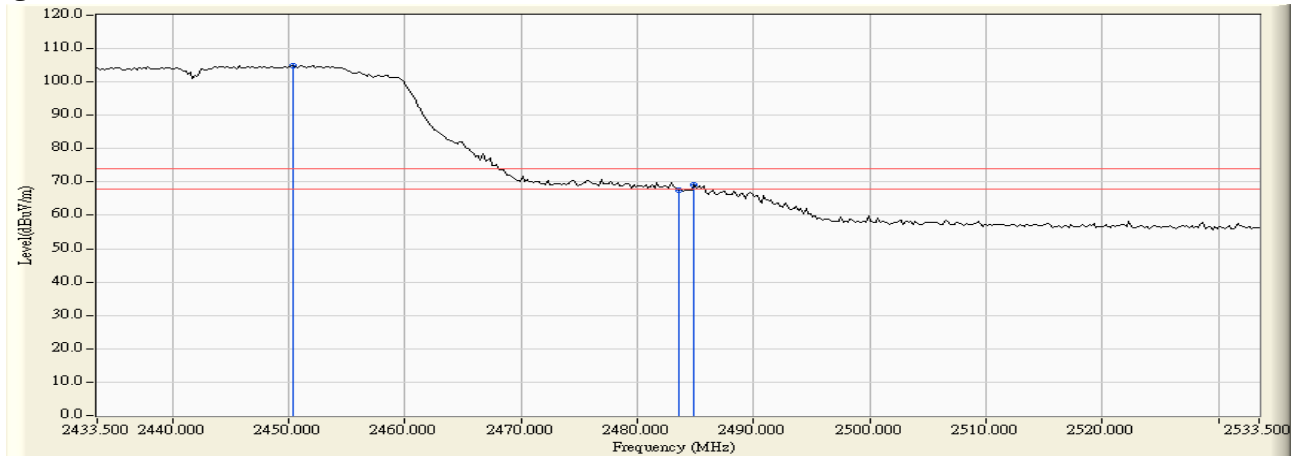

**Figure Channel 07: Horizontal (Average)**

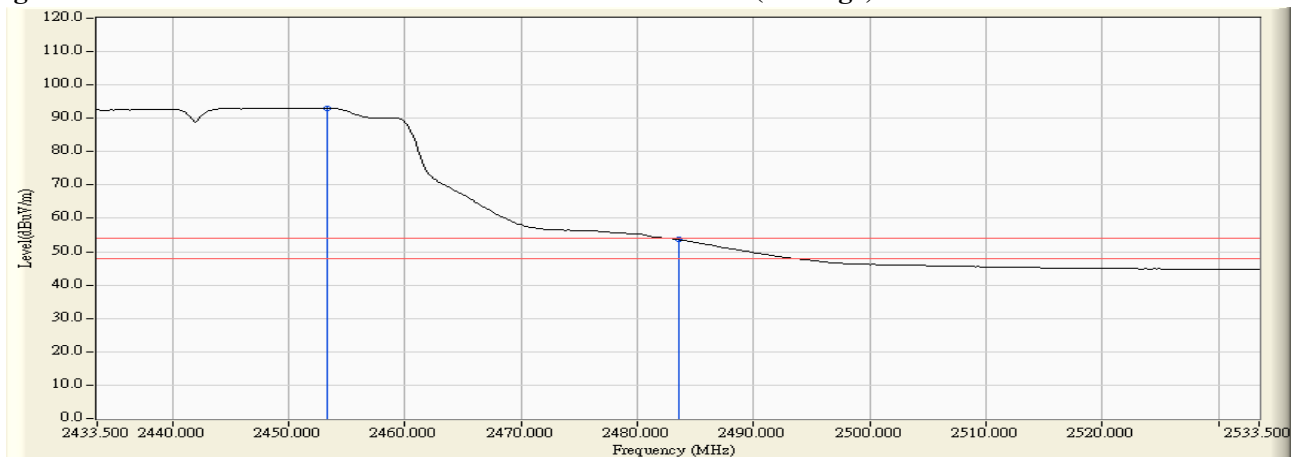

Note:

1. All readings above 1GHz are performed with peak and/or average measurements as necessary.
2. Peak measurements: RBW = 1MHz, VBW = 3 MHz, Sweep: Auto.
3. Average measurements: RBW = 1MHz, VBW = 10 Hz, Sweep: Auto.
4. “ \* ”, means this data is the worst emission level.
5. Measurement Level = Reading Level + Correct Factor.
6. The average measurement was not performed when the peak measured data under the limit of average detection.



Product : Intel® Dual Band Wireless-AC 8260  
 Test Item : Band Edge  
 Test Site : No.3 OATS  
 Test Mode : Mode 1 SISO A: Transmit - 802.11n-40BW\_15Mbps(2.4G Band)

**RF Radiated Measurement (Vertical):**

Channel No.	Frequency (MHz)	Correct Factor (dB)	Reading Level (dBuV)	Emission Level (dBuV/m)	Peak Limit (dBuV/m)	Average Limit (dBuV/m)	Result
07 (Peak)	2451.100	31.216	69.412	100.627	--	--	Pass
07 (Peak)	2483.500	31.435	31.493	62.928	74.00	54.00	Pass
07 (Average)	2453.100	31.229	57.888	89.117	--	--	Pass
07 (Average)	2483.500	31.435	17.050	48.485	74.00	54.00	Pass

**Figure Channel 07: Vertical (Peak)**

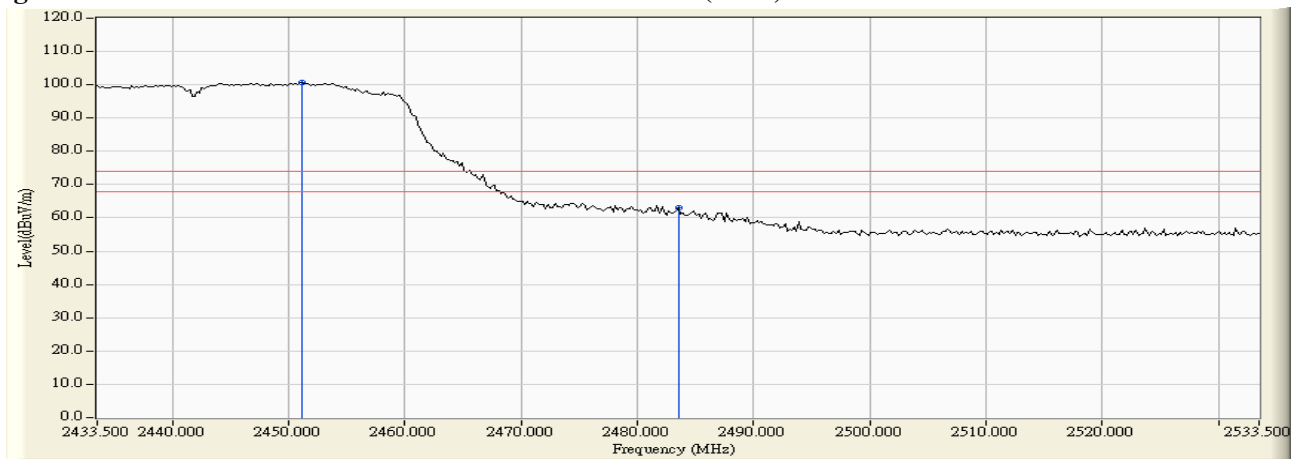

**Figure Channel 07: Vertical (Average)**

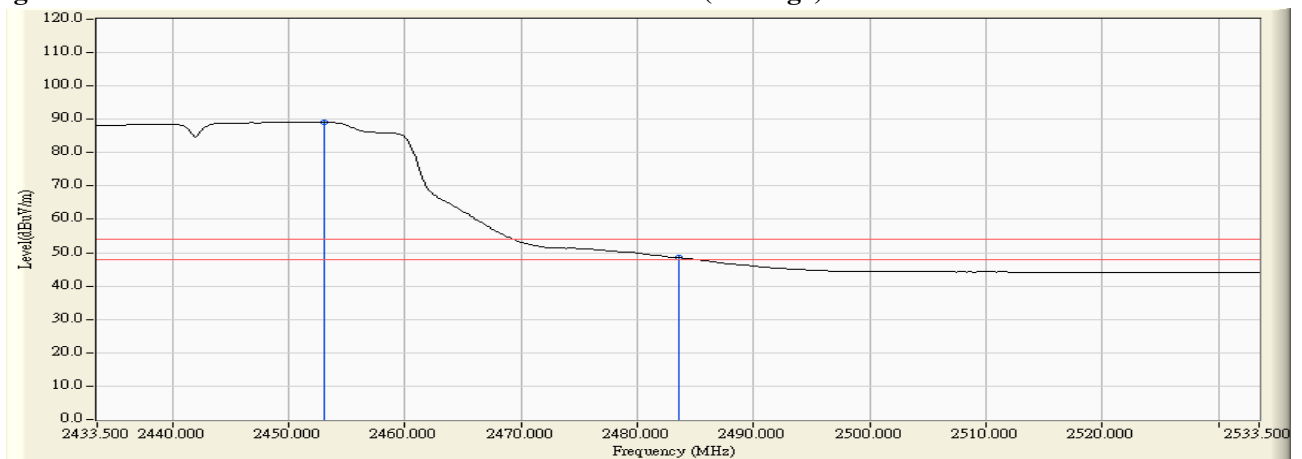

Note:

1. All readings above 1GHz are performed with peak and/or average measurements as necessary.
2. Peak measurements: RBW = 1MHz, VBW = 3 MHz, Sweep: Auto.
3. Average measurements: RBW = 1MHz, VBW = 10 Hz, Sweep: Auto.
4. “ \* ”, means this data is the worst emission level.
5. Measurement Level = Reading Level + Correct Factor.
6. The average measurement was not performed when the peak measured data under the limit of average detection.

Product : Intel® Dual Band Wireless-AC 8260  
 Test Item : Band Edge  
 Test Site : No.3 OATS  
 Test Mode : Mode 1 SISO A: Transmit - 802.11n-40BW\_15Mbps(2.4G Band)

**RF Radiated Measurement (Horizontal):**

Channel No.	Frequency (MHz)	Correct Factor (dB)	Reading Level (dBuV)	Emission Level (dBuV/m)	Peak Limit (dBuV/m)	Average Limit (dBuV/m)	Result
08 (Peak)	2451.500	31.939	72.061	104.001	--	--	Pass
08 (Peak)	2483.500	32.182	34.503	66.685	74.00	54.00	Pass
08 (Peak)	2486.500	32.206	34.850	67.055	74.00	54.00	Pass
08 (Average)	2455.500	31.971	60.344	92.314	--	--	Pass
08 (Average)	2483.500	32.182	21.337	53.519	74.00	54.00	Pass

**Figure Channel 08: Horizontal (Peak)**

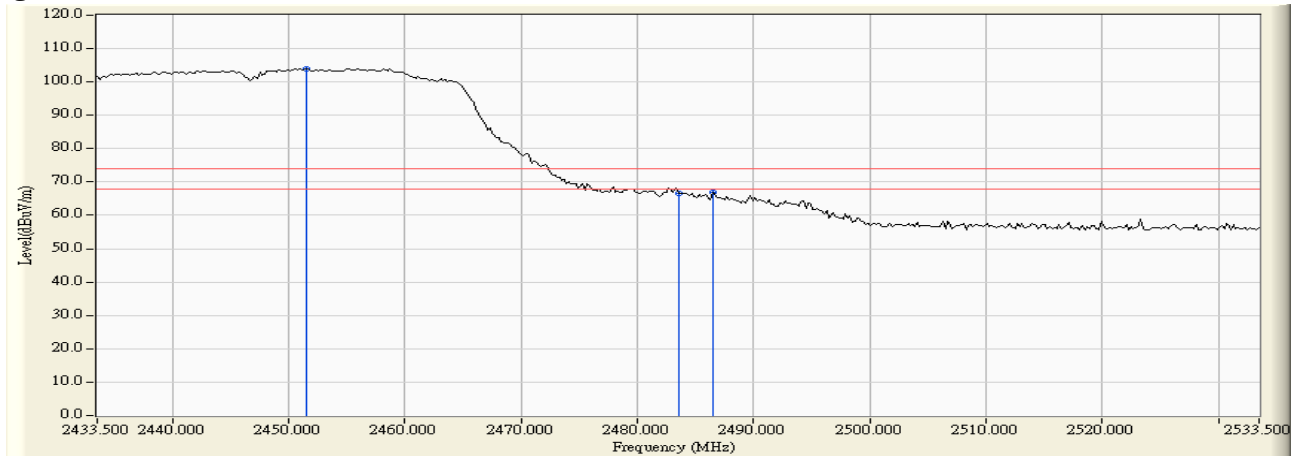

**Figure Channel 08: Horizontal (Average)**

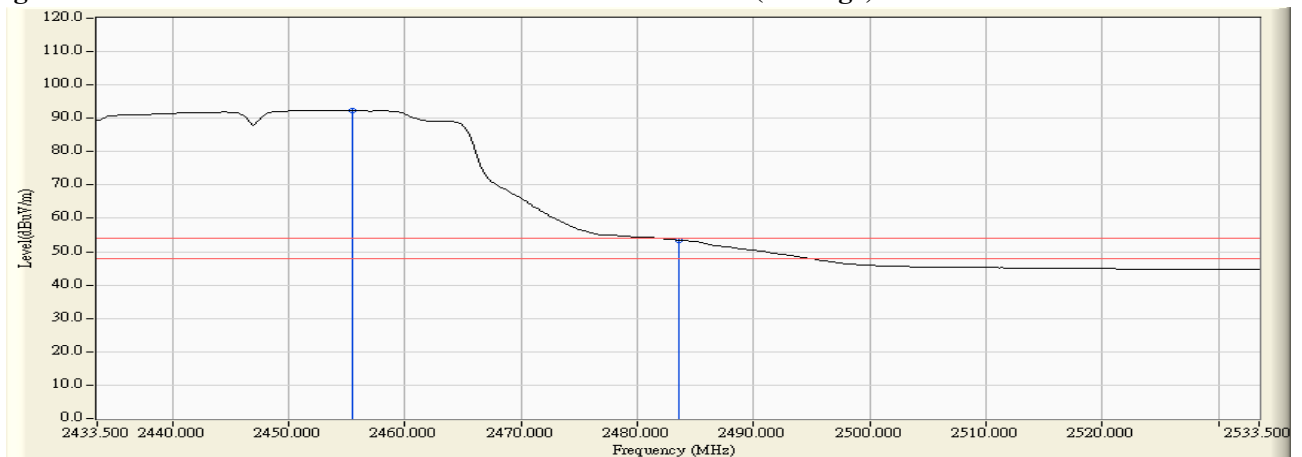

Note:

1. All readings above 1GHz are performed with peak and/or average measurements as necessary.
2. Peak measurements: RBW = 1MHz, VBW = 3 MHz, Sweep: Auto.
3. Average measurements: RBW = 1MHz, VBW = 10 Hz, Sweep: Auto.
4. “ \* ”, means this data is the worst emission level.
5. Measurement Level = Reading Level + Correct Factor.
6. The average measurement was not performed when the peak measured data under the limit of average detection.

Product : Intel® Dual Band Wireless-AC 8260  
 Test Item : Band Edge  
 Test Site : No.3 OATS  
 Test Mode : Mode 1 SISO A: Transmit - 802.11n-40BW\_15Mbps(2.4G Band)

**RF Radiated Measurement (Vertical):**

Channel No.	Frequency (MHz)	Correct Factor (dB)	Reading Level (dBuV)	Emission Level (dBuV/m)	Peak Limit (dBuV/m)	Average Limit (dBuV/m)	Result
08 (Peak)	2451.300	31.217	68.672	99.889	--	--	Pass
08 (Peak)	2483.500	31.435	32.253	63.688	74.00	54.00	Pass
08 (Peak)	2484.300	31.440	32.351	63.792	74.00	54.00	Pass
08 (Average)	2451.900	31.221	57.123	88.344	--	--	Pass
08 (Average)	2483.500	31.435	18.477	49.912	74.00	54.00	Pass

**Figure Channel 08: Vertical (Peak)**

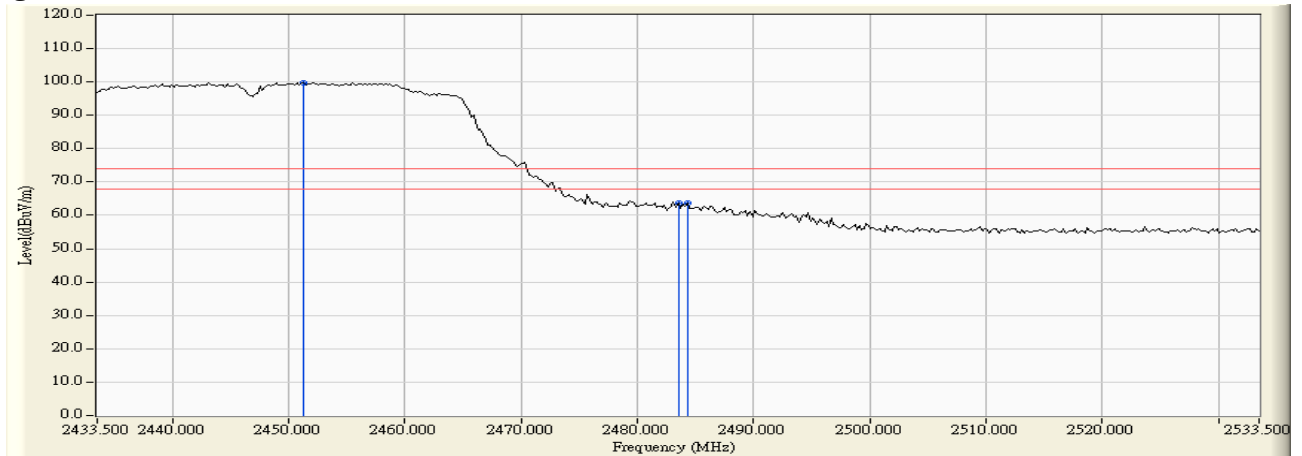

**Figure Channel 08: Vertical (Average)**

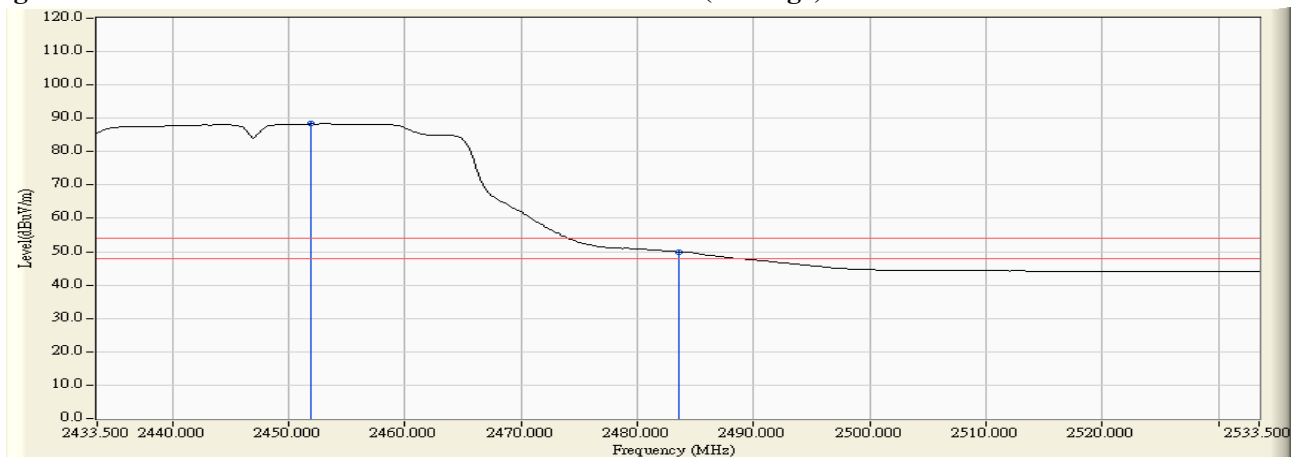

Note:

1. All readings above 1GHz are performed with peak and/or average measurements as necessary.
2. Peak measurements: RBW = 1MHz, VBW = 3 MHz, Sweep: Auto.
3. Average measurements: RBW = 1MHz, VBW = 10 Hz, Sweep: Auto.
4. “ \* ”, means this data is the worst emission level.
5. Measurement Level = Reading Level + Correct Factor.
6. The average measurement was not performed when the peak measured data under the limit of average detection.

Product : Intel® Dual Band Wireless-AC 8260  
 Test Item : Band Edge  
 Test Site : No.3 OATS  
 Test Mode : Mode 1 SISO A: Transmit - 802.11n-40BW\_15Mbps(2.4G Band)

**RF Radiated Measurement (Horizontal):**

Channel No.	Frequency (MHz)	Correct Factor (dB)	Reading Level (dBuV)	Emission Level (dBuV/m)	Peak Limit (dBuV/m)	Average Limit (dBuV/m)	Result
09 (Peak)	2455.900	31.973	72.804	104.777	--	--	Pass
09 (Peak)	2483.500	32.182	33.732	65.914	74.00	54.00	Pass
09 (Peak)	2484.300	32.187	34.808	66.996	74.00	54.00	Pass
09 (Average)	2463.300	32.029	60.794	92.823	--	--	Pass
09 (Average)	2483.500	32.182	21.267	53.449	74.00	54.00	Pass

**Figure Channel 09: Horizontal (Peak)**

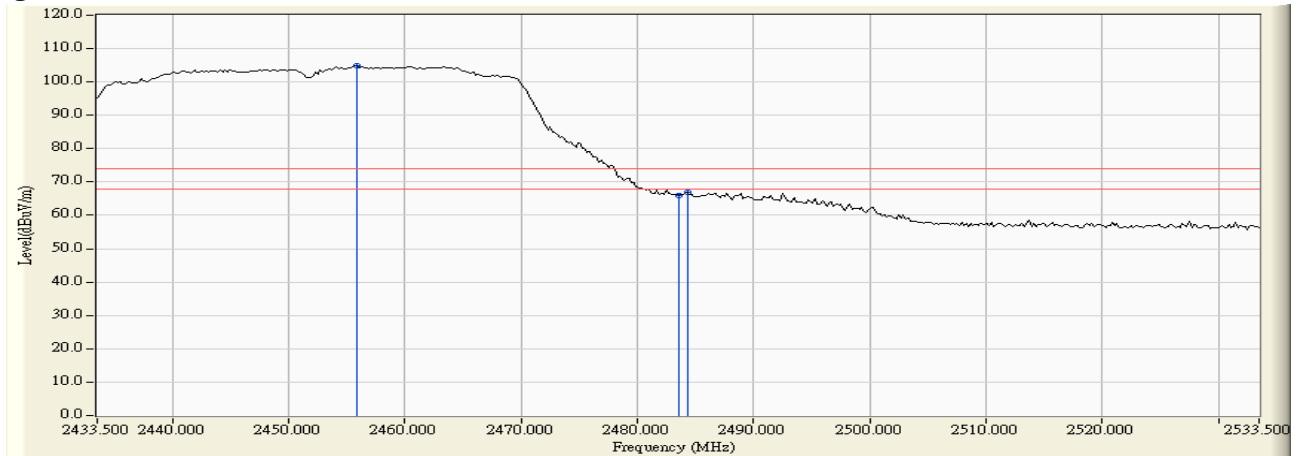

**Figure Channel 09: Horizontal (Average)**

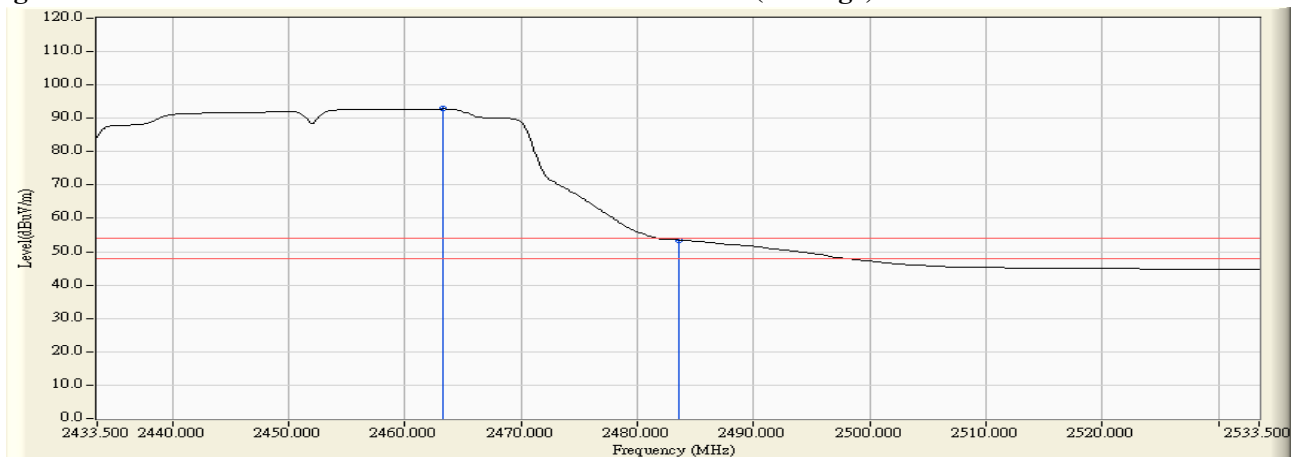

Note:

1. All readings above 1GHz are performed with peak and/or average measurements as necessary.
2. Peak measurements: RBW = 1MHz, VBW = 3 MHz, Sweep: Auto.
3. Average measurements: RBW = 1MHz, VBW = 10 Hz, Sweep: Auto.
4. “ \* ”, means this data is the worst emission level.
5. Measurement Level = Reading Level + Correct Factor.
6. The average measurement was not performed when the peak measured data under the limit of average detection.



Product : Intel® Dual Band Wireless-AC 8260  
 Test Item : Band Edge  
 Test Site : No.3 OATS  
 Test Mode : Mode 1 SISO A: Transmit - 802.11n-40BW\_15Mbps(2.4G Band)

**RF Radiated Measurement (Vertical):**

Channel No.	Frequency (MHz)	Correct Factor (dB)	Reading Level (dBuV)	Emission Level (dBuV/m)	Peak Limit (dBuV/m)	Average Limit (dBuV/m)	Result
09 (Peak)	2447.300	31.189	68.598	99.787	--	--	Pass
09 (Peak)	2483.500	31.435	29.855	61.290	74.00	54.00	Pass
09 (Average)	2455.500	31.246	56.999	88.245	--	--	Pass
09 (Average)	2483.500	31.435	17.558	48.993	74.00	54.00	Pass

**Figure Channel 09: Vertical (Peak)**

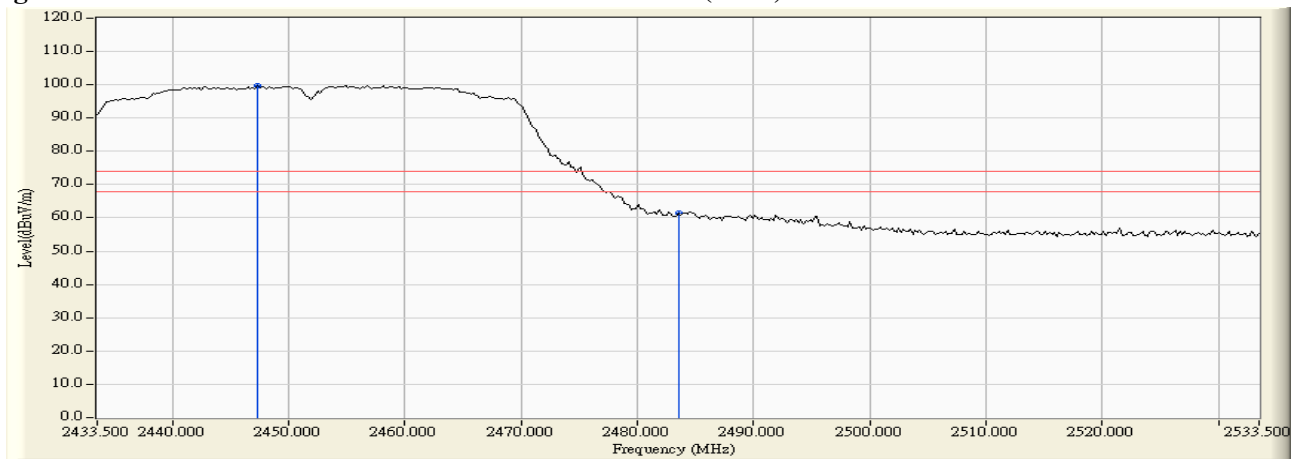

**Figure Channel 09: Vertical (Average)**

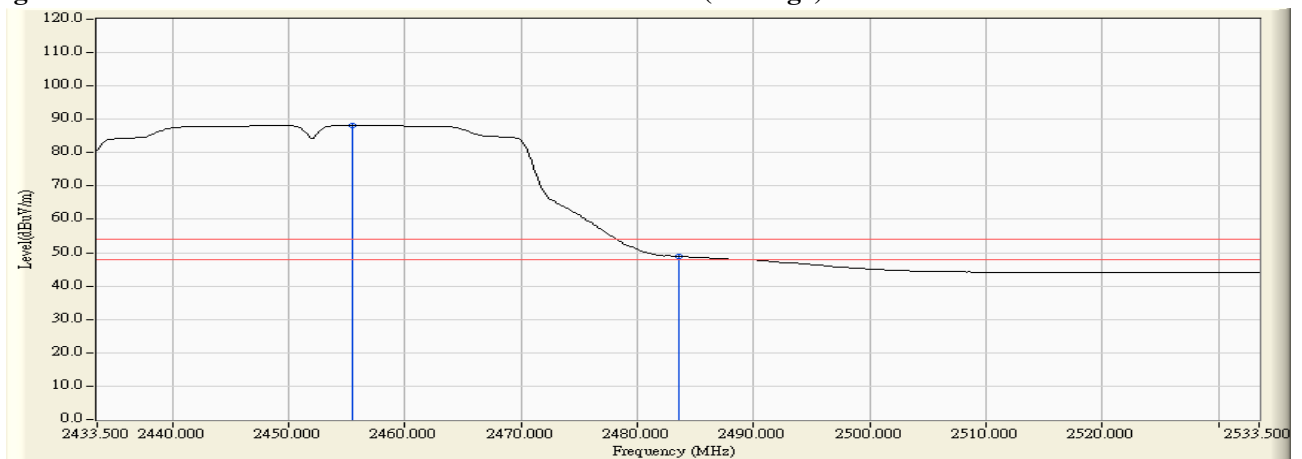

Note:

1. All readings above 1GHz are performed with peak and/or average measurements as necessary.
2. Peak measurements: RBW = 1MHz, VBW = 3 MHz, Sweep: Auto.
3. Average measurements: RBW = 1MHz, VBW = 10 Hz, Sweep: Auto.
4. “ \* ”, means this data is the worst emission level.
5. Measurement Level = Reading Level + Correct Factor.
6. The average measurement was not performed when the peak measured data under the limit of average detection.

Product : Intel® Dual Band Wireless-AC 8260  
 Test Item : Band Edge  
 Test Site : No.3 OATS  
 Test Mode : Mode 1 SISO A: Transmit - 802.11n-40BW\_15Mbps(2.4G Band)

**RF Radiated Measurement (Horizontal):**

Channel No.	Frequency (MHz)	Correct Factor (dB)	Reading Level (dBuV)	Emission Level (dBuV/m)	Peak Limit (dBuV/m)	Average Limit (dBuV/m)	Result
10 (Peak)	2465.500	32.046	69.407	101.453	--	--	Pass
10 (Peak)	2483.500	32.182	34.393	66.575	74.00	54.00	Pass
10 (Average)	2468.100	32.065	57.751	89.816	--	--	Pass
10 (Average)	2483.500	32.182	21.397	53.579	74.00	54.00	Pass

**Figure Channel 10: Horizontal (Peak)**

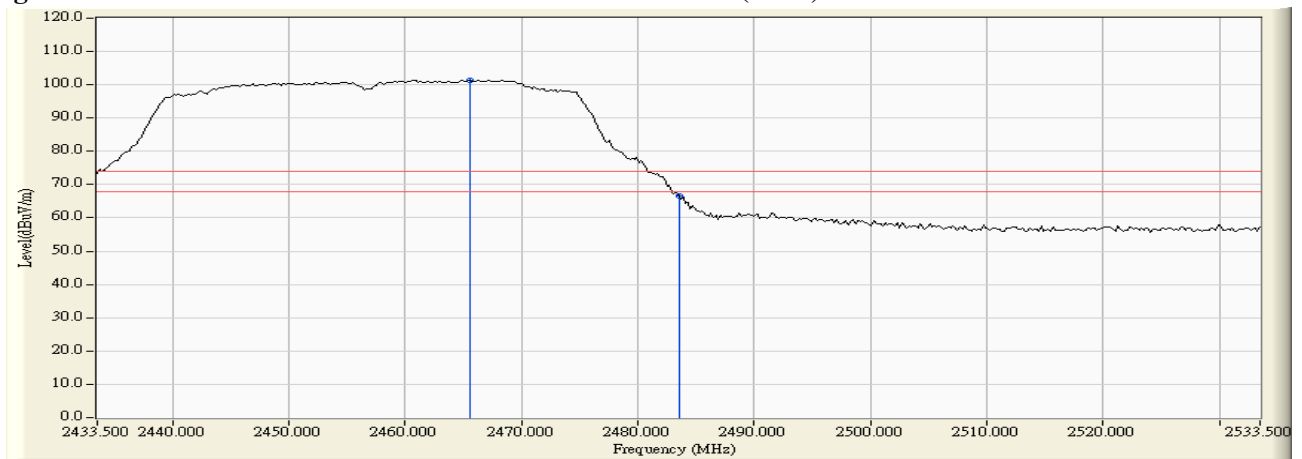

**Figure Channel 10: Horizontal (Average)**

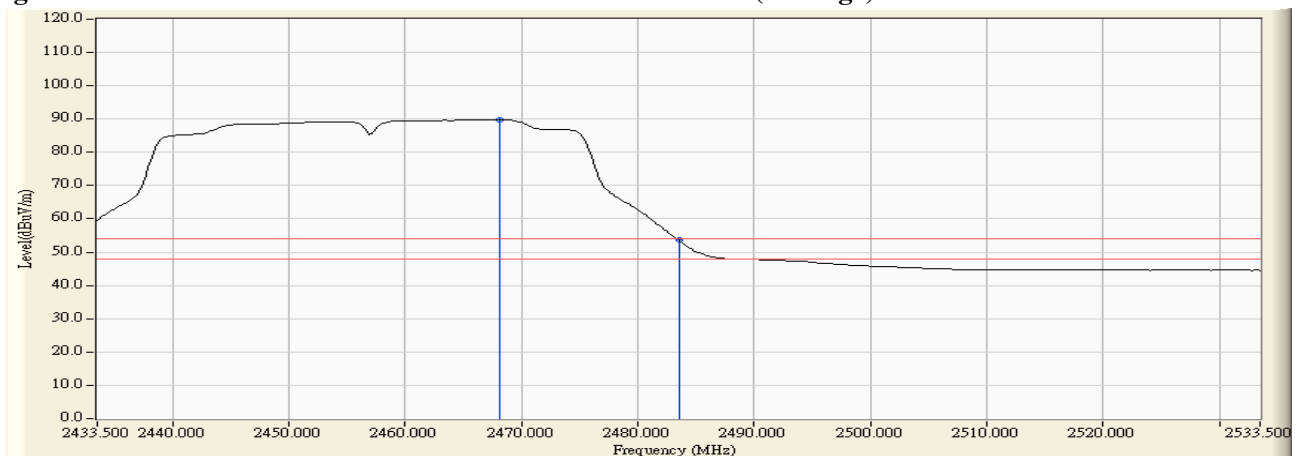

Note:

1. All readings above 1GHz are performed with peak and/or average measurements as necessary.
2. Peak measurements: RBW = 1MHz, VBW = 3 MHz, Sweep: Auto.
3. Average measurements: RBW = 1MHz, VBW = 10 Hz, Sweep: Auto.
4. “ \* ”, means this data is the worst emission level.
5. Measurement Level = Reading Level + Correct Factor.
6. The average measurement was not performed when the peak measured data under the limit of average detection.

Product : Intel® Dual Band Wireless-AC 8260  
 Test Item : Band Edge  
 Test Site : No.3 OATS  
 Test Mode : Mode 1 SISO A: Transmit - 802.11n-40BW\_15Mbps(2.4G Band)

**RF Radiated Measurement (Vertical):**

Channel No.	Frequency (MHz)	Correct Factor (dB)	Reading Level (dBuV)	Emission Level (dBuV/m)	Peak Limit (dBuV/m)	Average Limit (dBuV/m)	Result
10 (Peak)	2461.300	31.286	66.336	97.622	--	--	Pass
10 (Peak)	2483.500	31.435	29.540	60.975	74.00	54.00	Pass
10 (Average)	2459.500	31.273	54.948	86.221	--	--	Pass
10 (Average)	2483.500	31.435	18.286	49.721	74.00	54.00	Pass

**Figure Channel 10: Vertical (Peak)**

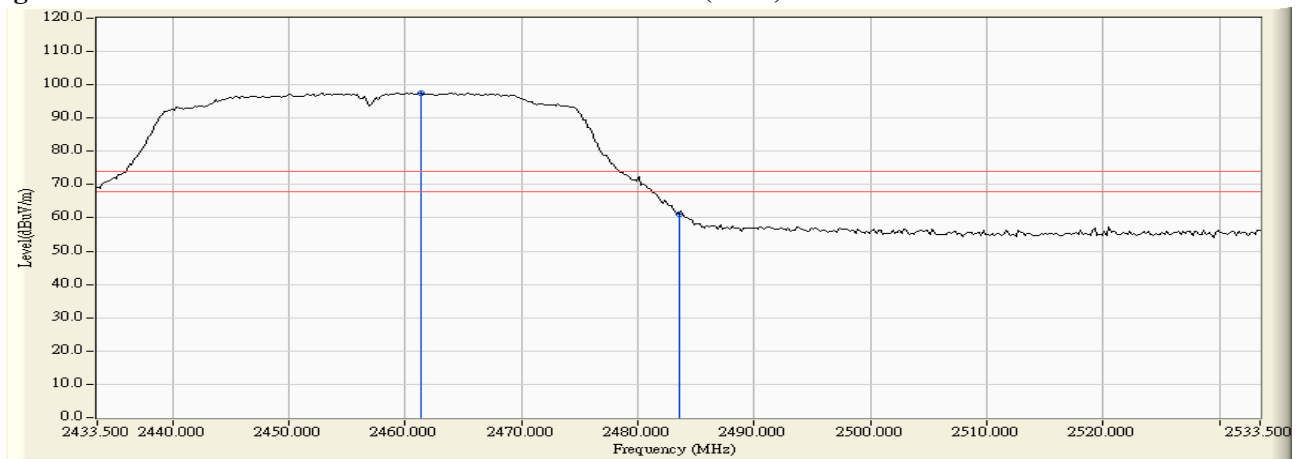

**Figure Channel 10: Vertical (Average)**

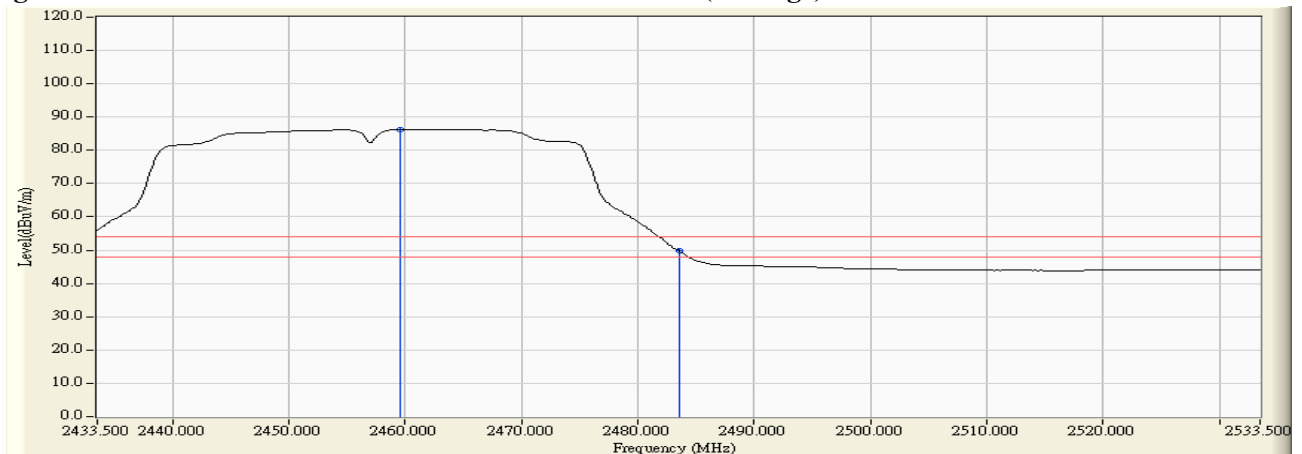

Note:

1. All readings above 1GHz are performed with peak and/or average measurements as necessary.
2. Peak measurements: RBW = 1MHz, VBW = 3 MHz, Sweep: Auto.
3. Average measurements: RBW = 1MHz, VBW = 10 Hz, Sweep: Auto.
4. “ \* ”, means this data is the worst emission level.
5. Measurement Level = Reading Level + Correct Factor.
6. The average measurement was not performed when the peak measured data under the limit of average detection.

Product : Intel® Dual Band Wireless-AC 8260  
 Test Item : Band Edge  
 Test Site : No.3 OATS  
 Test Mode : Mode 1 SISO A: Transmit - 802.11a 6Mbps

Test Frequency (MHz)	Measurement Level $\Delta$ (dB)	Limit $\Delta$ (dB)	Result
5745	46.54	>20	PASS

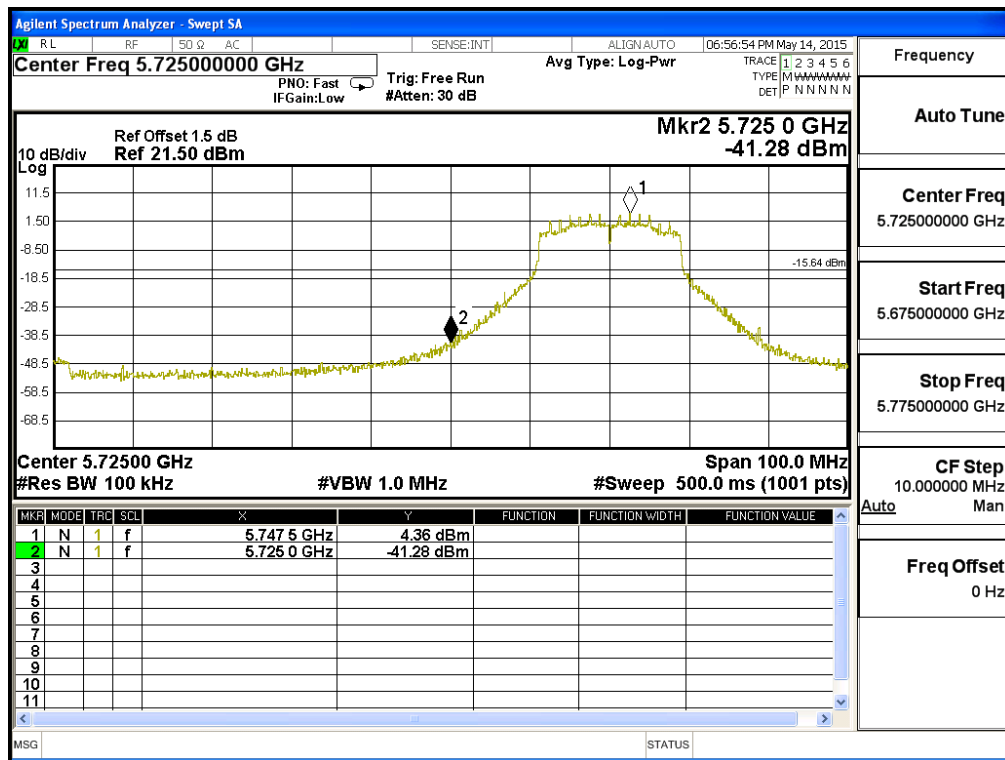

Product : Intel® Dual Band Wireless-AC 8260  
 Test Item : Band Edge  
 Test Site : No.3 OATS  
 Test Mode : Mode 1 SISO A: Transmit - 802.11a 6Mbps

Test Frequency (MHz)	Measurement Level $\Delta$ (dB)	Limit $\Delta$ (dB)	Result
5825	53.30	>20	PASS

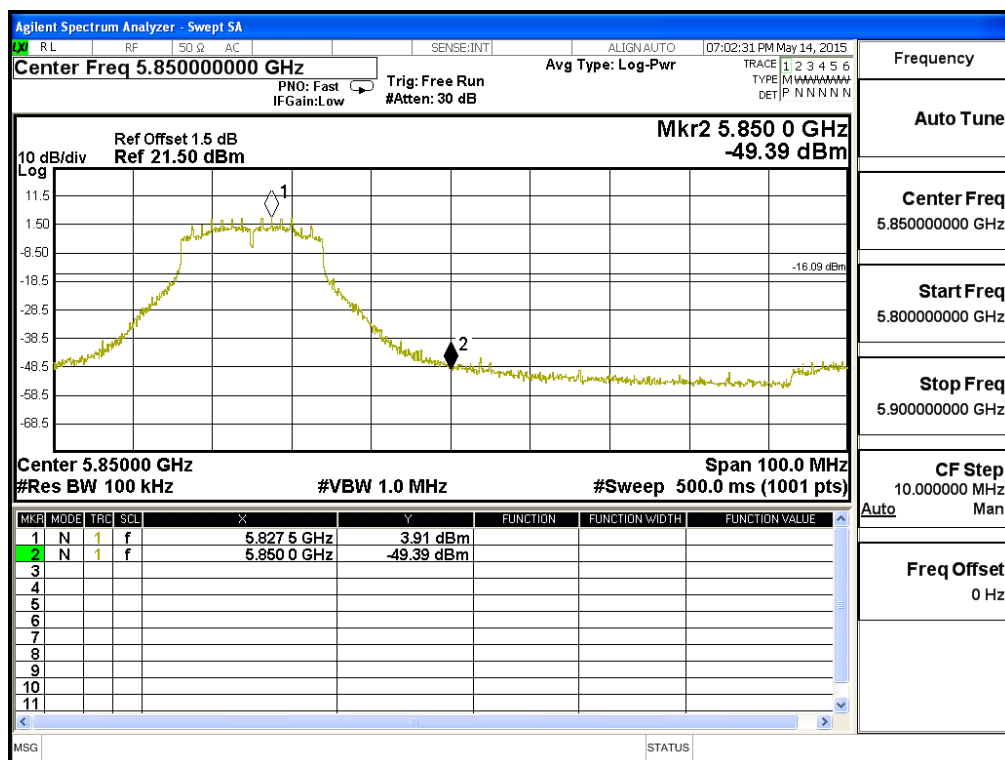



Product : Intel® Dual Band Wireless-AC 8260  
 Test Item : Band Edge  
 Test Site : No.3 OATS  
 Test Mode : Mode 1 SISO A: Transmit - 802.11n-20BW\_7.2Mbps(5G Band)

Test Frequency (MHz)	Measurement Level $\Delta$ (dB)	Limit $\Delta$ (dB)	Result
5745	46.20	>20	PASS

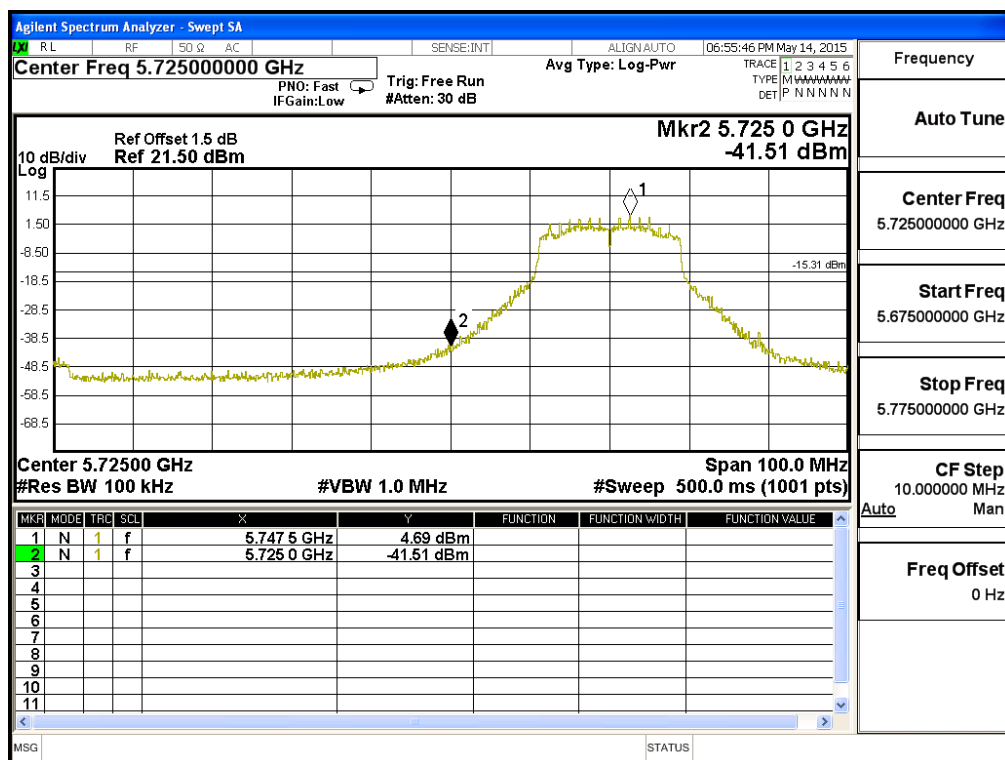

Product : Intel® Dual Band Wireless-AC 8260  
 Test Item : Band Edge  
 Test Site : No.3 OATS  
 Test Mode : Mode 1 SISO A: Transmit - 802.11n-20BW\_7.2Mbps(5G Band)

Test Frequency (MHz)	Measurement Level $\Delta$ (dB)	Limit $\Delta$ (dB)	Result
5825	52.93	>20	PASS

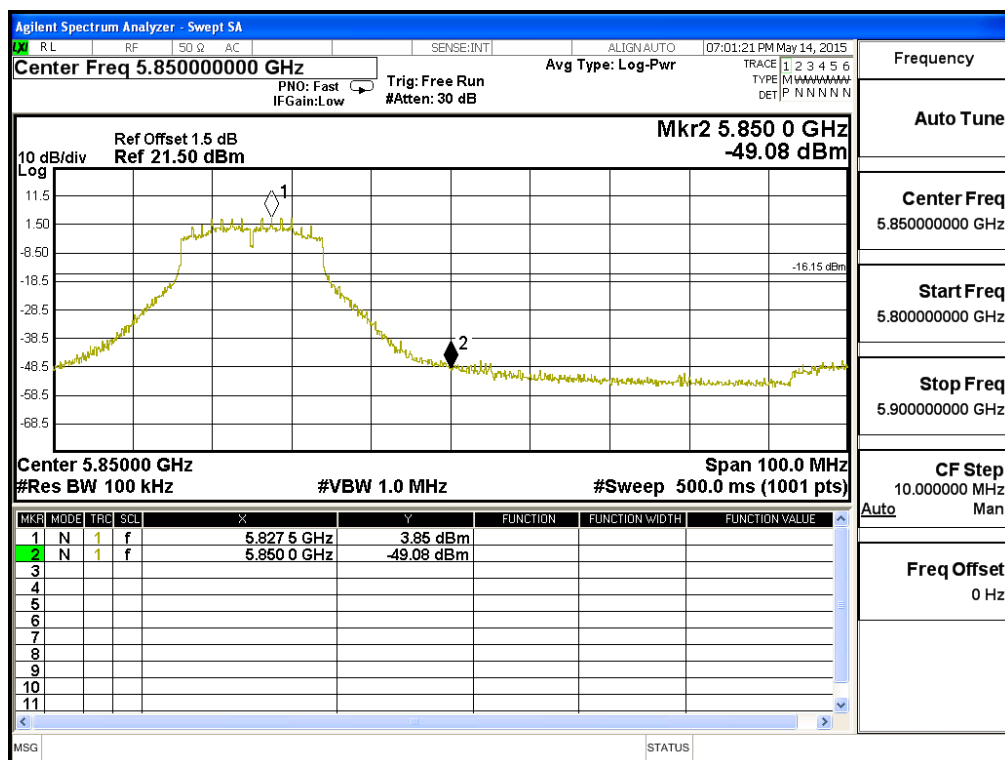

Product : Intel® Dual Band Wireless-AC 8260  
 Test Item : Band Edge  
 Test Site : No.3 OATS  
 Test Mode : Mode 1 SISO A: Transmit - 802.11n-40BW\_15Mbps(5G Band)

Test Frequency (MHz)	Measurement Level $\Delta$ (dB)	Limit $\Delta$ (dB)	Result
5755	40.70	>20	PASS

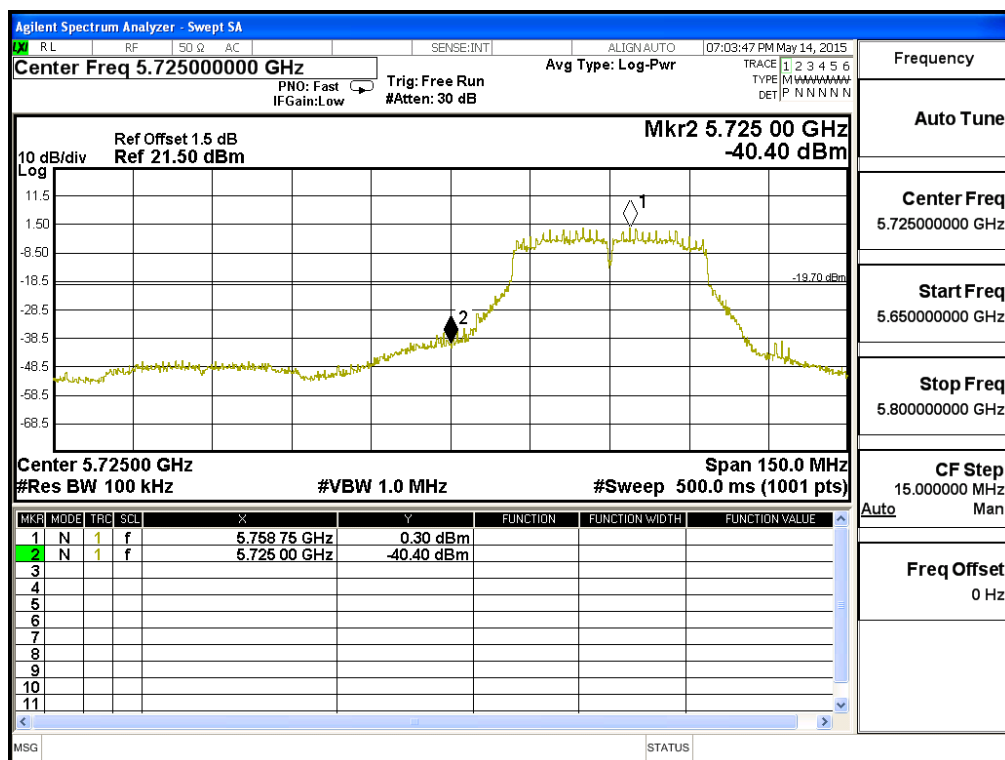

Product : Intel® Dual Band Wireless-AC 8260  
 Test Item : Band Edge  
 Test Site : No.3 OATS  
 Test Mode : Mode 1 SISO A: Transmit - 802.11n-40BW\_15Mbps(5G Band)

Test Frequency (MHz)	Measurement Level $\Delta$ (dB)	Limit $\Delta$ (dB)	Result
5795	53.22	>20	PASS

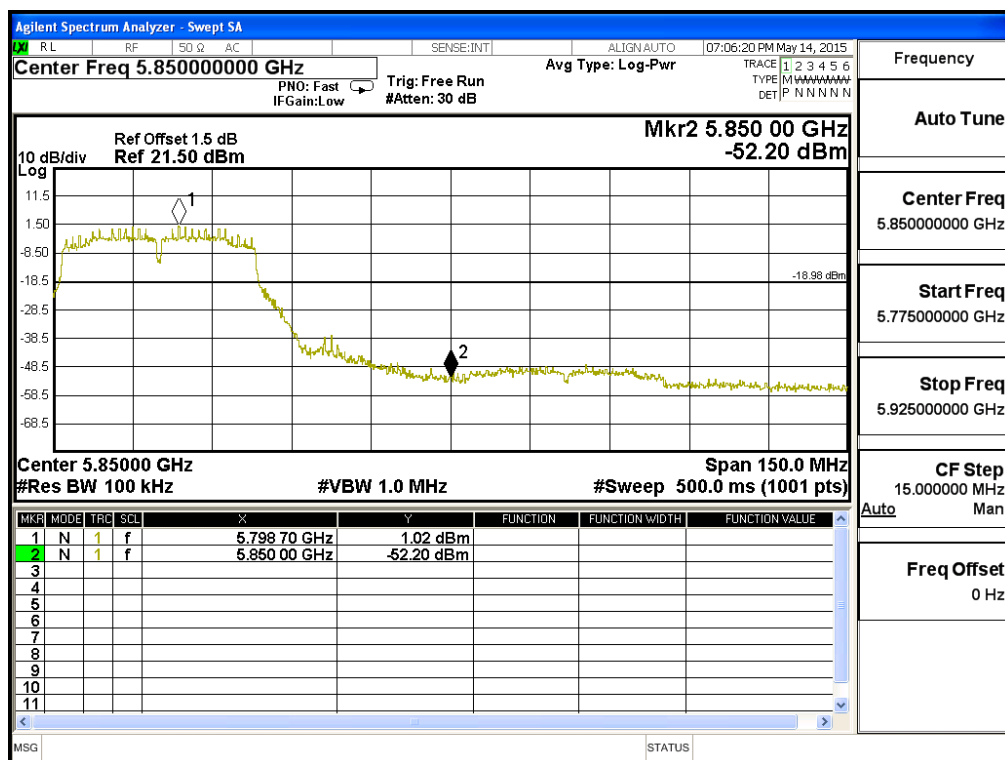

Product : Intel® Dual Band Wireless-AC 8260  
 Test Item : Band Edge  
 Test Site : No.3 OATS  
 Test Mode : Mode 1 SISO A: Transmit - 802.11ac-80BW\_32.5Mbps(5G Band)

Test Frequency (MHz)	Measurement Level $\Delta$ (dB)	Limit $\Delta$ (dB)	Result
5775	36.83	>30	PASS

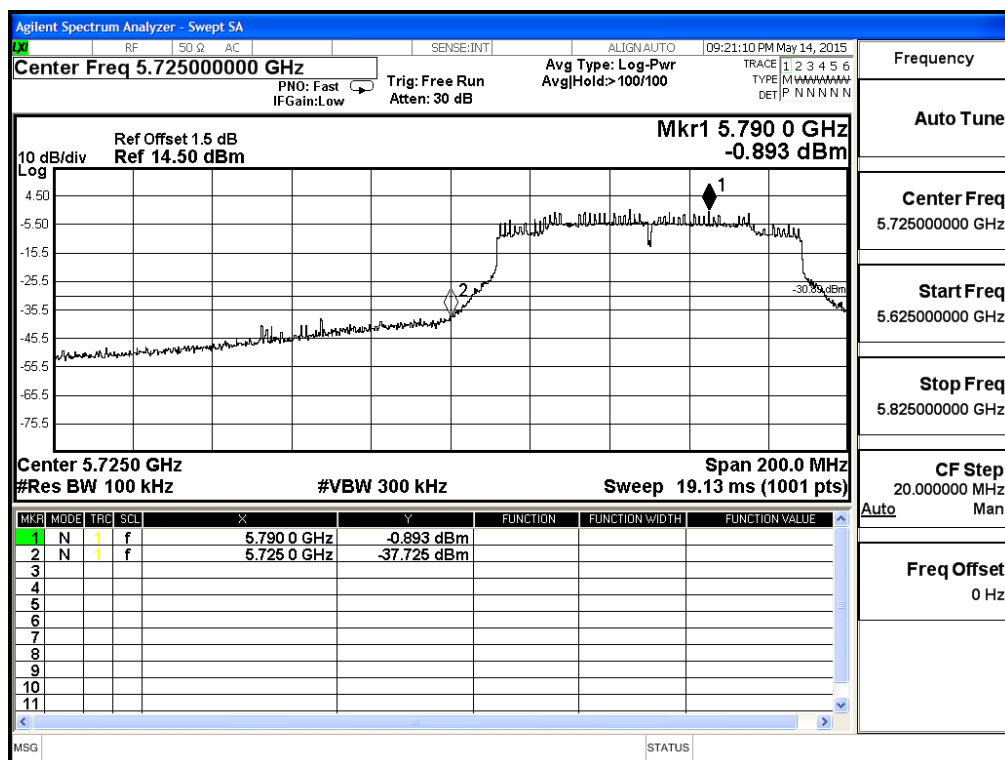

Product : Intel® Dual Band Wireless-AC 8260  
 Test Item : Band Edge  
 Test Site : No.3 OATS  
 Test Mode : Mode 2 SISO B: Transmit (802.11b 1Mbps)

**RF Radiated Measurement (Horizontal):**

Channel No.	Frequency (MHz)	Correct Factor (dB)	Reading Level (dBuV)	Emission Level (dBuV/m)	Peak Limit (dBuV/m)	Average Limit (dBuV/m)	Result
01 (Peak)	2390.000	31.509	39.637	71.146	74.00	54.00	Pass
01 (Peak)	2400.000	31.561	48.474	80.035	74.00	54.00	Pass
01 (Peak)	2413.800	31.651	78.522	110.174	--	--	Pass
01 (Average)	2385.600	31.492	21.552	53.044	74.00	54.00	Pass
01 (Average)	2390.000	31.509	14.949	46.458	74.00	54.00	Pass
01 (Average)	2400.000	31.561	26.498	58.059	74.00	54.00	Pass
01 (Average)	2412.800	31.645	73.143	104.787	--	--	Pass

**Figure Channel 01: Horizontal (Peak)**

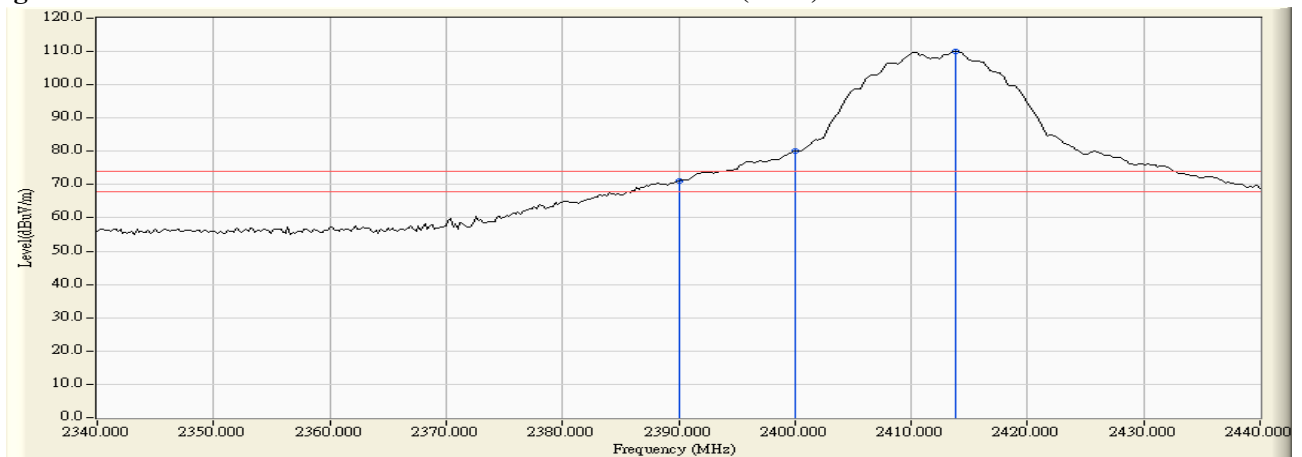

**Figure Channel 01: Horizontal (Average)**

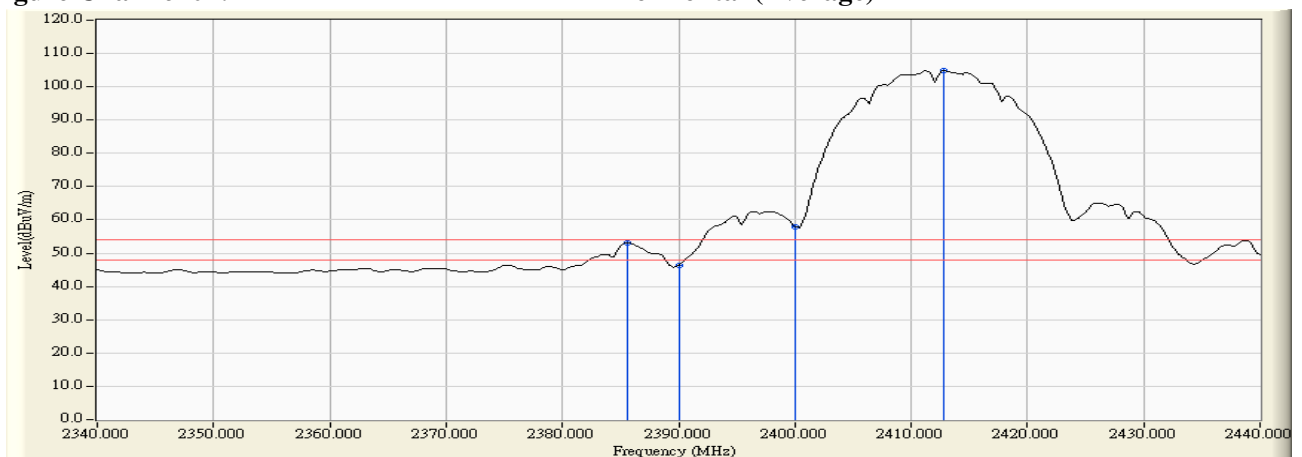

Note:

1. All readings above 1GHz are performed with peak and/or average measurements as necessary.
2. Peak measurements: RBW = 1MHz, VBW = 3 MHz, Sweep: Auto.
3. Average measurements: RBW = 1MHz, VBW = 10 Hz, Sweep: Auto.
4. “ \* ”, means this data is the worst emission level.
5. Measurement Level = Reading Level + Correct Factor.
6. The average measurement was not performed when the peak measured data under the limit of average detection.

Product : Intel® Dual Band Wireless-AC 8260  
 Test Item : Band Edge  
 Test Site : No.3 OATS  
 Test Mode : Mode 2 SISO B: Transmit (802.11b 1Mbps)

**RF Radiated Measurement (Vertical):**

Channel No.	Frequency (MHz)	Correct Factor (dB)	Reading Level (dBuV)	Emission Level (dBuV/m)	Peak Limit (dBuV/m)	Average Limit (dBuV/m)	Result
01 (Peak)	2390.000	30.915	36.108	67.023	74.00	54.00	Pass
01 (Peak)	2400.000	30.912	44.484	75.396	74.00	54.00	Pass
01 (Peak)	2413.800	30.961	74.972	105.933	--	--	Pass
01 (Average)	2385.600	30.936	18.525	49.461	74.00	54.00	Pass
01 (Average)	2390.000	30.915	13.685	44.600	74.00	54.00	Pass
01 (Average)	2400.000	30.912	23.050	53.962	74.00	54.00	Pass
01 (Average)	2412.800	30.955	69.608	100.563	--	--	Pass

**Figure Channel 01: Vertical (Peak)**

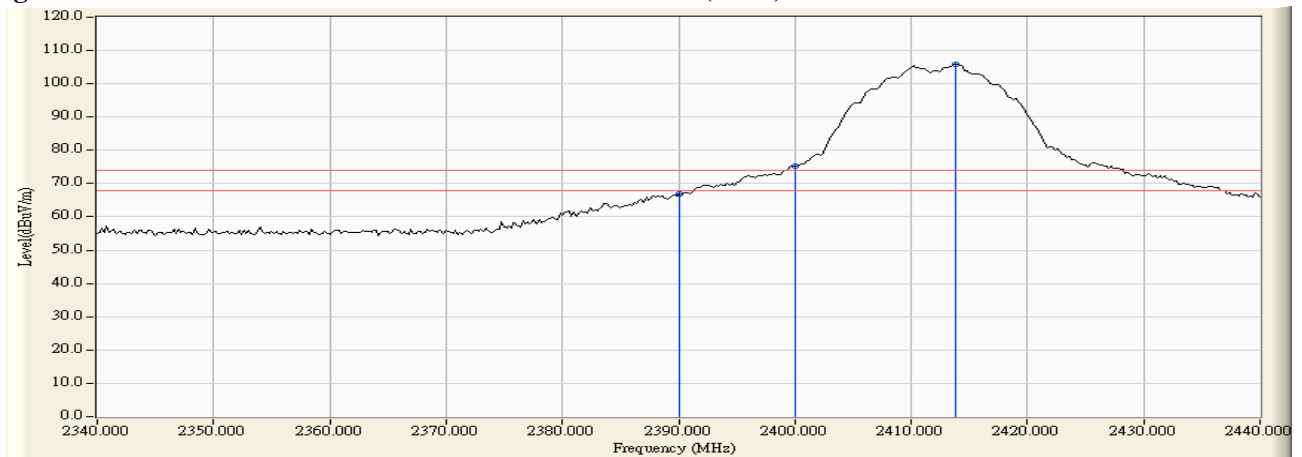

**Figure Channel 01: Vertical (Average)**

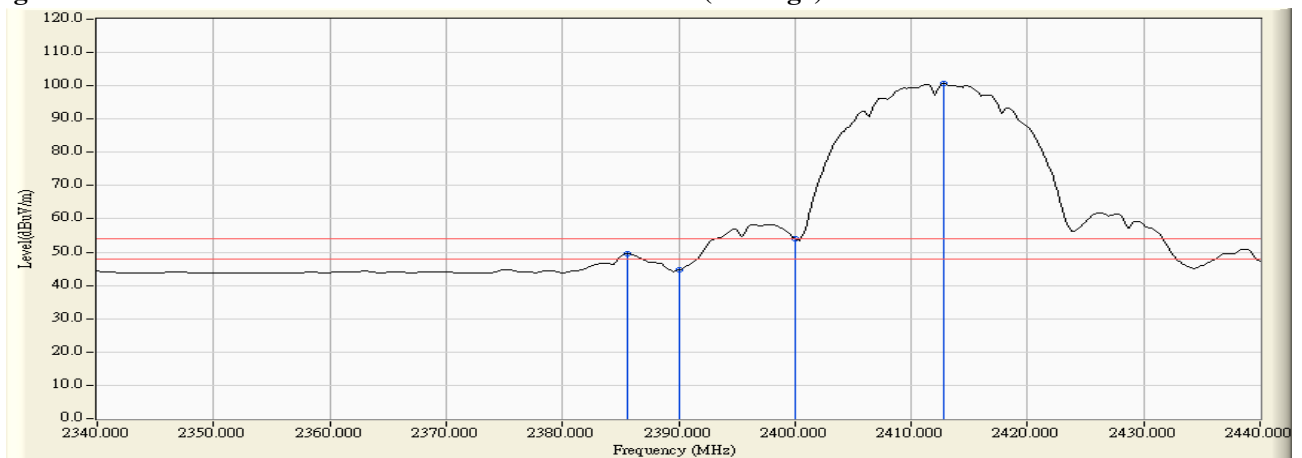



Note:

1. All readings above 1GHz are performed with peak and/or average measurements as necessary.
2. Peak measurements: RBW = 1MHz, VBW = 3 MHz, Sweep: Auto.
3. Average measurements: RBW = 1MHz, VBW = 10 Hz, Sweep: Auto.
4. “ \* ”, means this data is the worst emission level.
5. Measurement Level = Reading Level + Correct Factor.
6. The average measurement was not performed when the peak measured data under the limit of average detection.

Product : Intel® Dual Band Wireless-AC 8260  
 Test Item : Band Edge  
 Test Site : No.3 OATS  
 Test Mode : Mode 2 SISO B: Transmit (802.11b 1Mbps)

**RF Radiated Measurement (Horizontal):**

Channel No.	Frequency (MHz)	Correct Factor (dB)	Reading Level (dBuV)	Emission Level (dBuV/m)	Peak Limit (dBuV/m)	Average Limit (dBuV/m)	Result
02 (Peak)	2389.400	31.507	38.080	69.587	74.00	54.00	Pass
02 (Peak)	2390.000	31.509	37.528	69.037	74.00	54.00	Pass
02 (Peak)	2400.000	31.561	45.719	77.280	74.00	54.00	Pass
02 (Peak)	2415.400	31.664	80.427	112.091	--	--	Pass
02 (Average)	2390.000	31.509	19.122	50.631	74.00	54.00	Pass
02 (Average)	2400.000	31.561	36.131	67.692	74.00	54.00	Pass
02 (Average)	2416.400	31.672	75.121	106.793	--	--	Pass

**Figure Channel 02: Horizontal (Peak)**

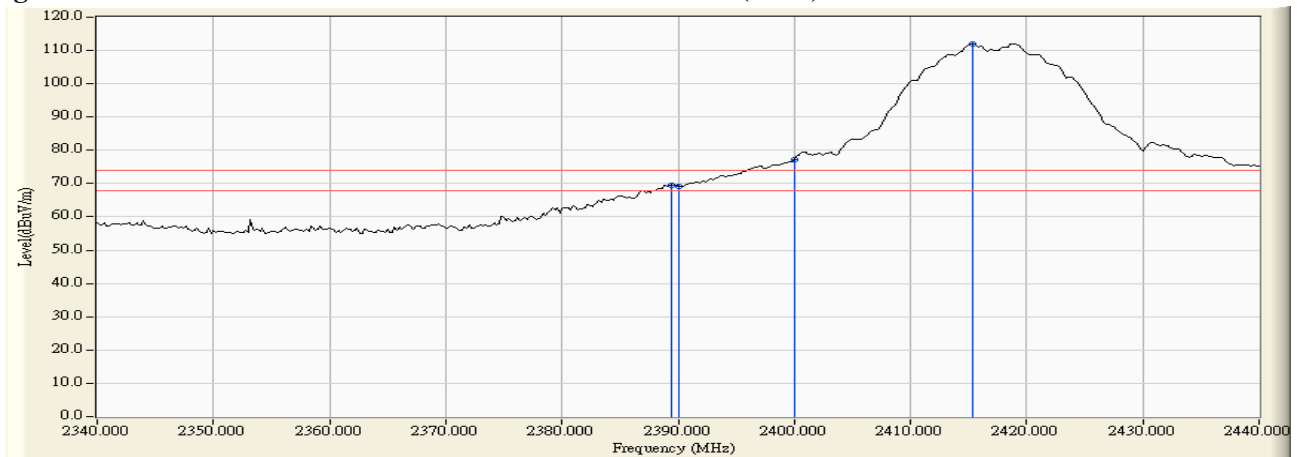

**Figure Channel 02: Horizontal (Average)**

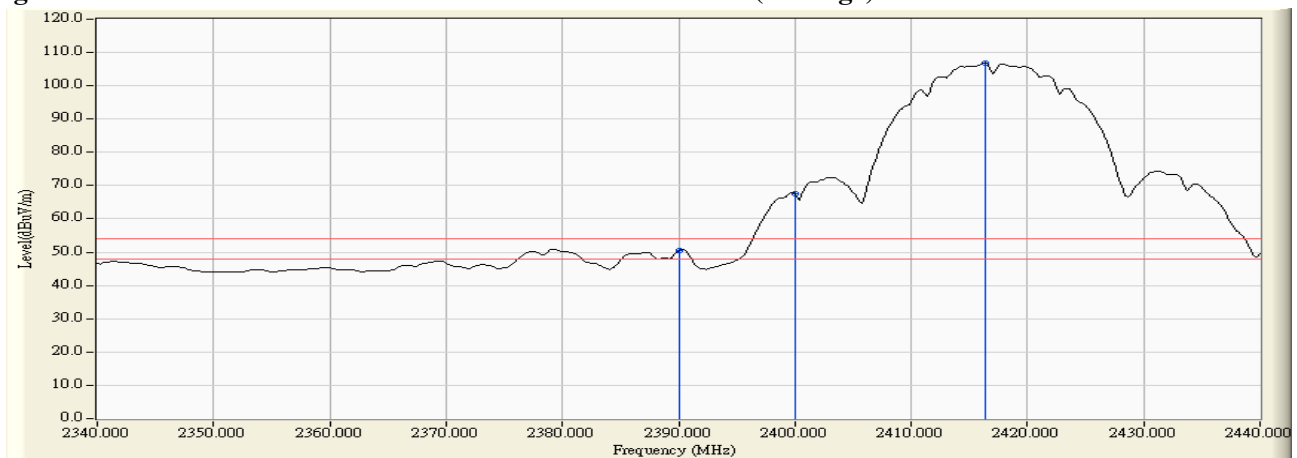

Note:

1. All readings above 1GHz are performed with peak and/or average measurements as necessary.
2. Peak measurements: RBW = 1MHz, VBW = 3 MHz, Sweep: Auto.
3. Average measurements: RBW = 1MHz, VBW = 10 Hz, Sweep: Auto.
4. “ \* ”, means this data is the worst emission level.
5. Measurement Level = Reading Level + Correct Factor.
6. The average measurement was not performed when the peak measured data under the limit of average detection.

Product : Intel® Dual Band Wireless-AC 8260  
 Test Item : Band Edge  
 Test Site : No.3 OATS  
 Test Mode : Mode 2 SISO B: Transmit (802.11b 1Mbps)

**RF Radiated Measurement (Vertical):**

Channel No.	Frequency (MHz)	Correct Factor (dB)	Reading Level (dBuV)	Emission Level (dBuV/m)	Peak Limit (dBuV/m)	Average Limit (dBuV/m)	Result
02 (Peak)	2389.200	30.919	34.930	65.849	74.00	54.00	Pass
02 (Peak)	2390.000	30.915	34.191	65.106	74.00	54.00	Pass
02 (Peak)	2400.000	30.912	41.389	72.301	74.00	54.00	Pass
02 (Peak)	2418.800	30.995	77.079	108.074	--	--	Pass
02 (Average)	2390.000	30.915	16.216	47.131	74.00	54.00	Pass
02 (Average)	2400.000	30.912	32.630	63.542	74.00	54.00	Pass
02 (Average)	2416.200	30.978	71.929	102.907	--	--	Pass

**Figure Channel 02: Vertical (Peak)**

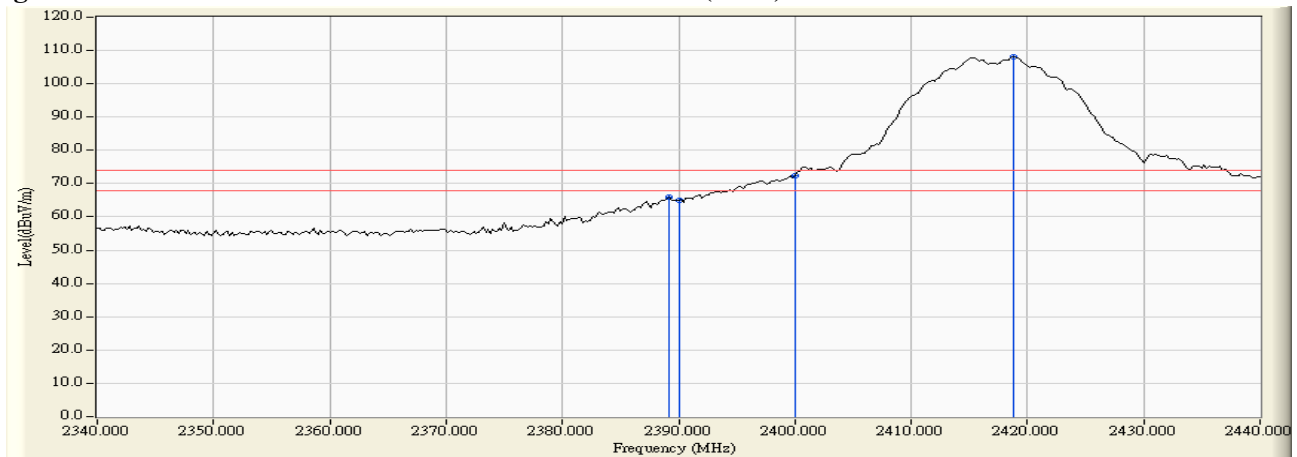

**Figure Channel 02: Vertical (Average)**



Note:

1. All readings above 1GHz are performed with peak and/or average measurements as necessary.
2. Peak measurements: RBW = 1MHz, VBW = 3 MHz, Sweep: Auto.
3. Average measurements: RBW = 1MHz, VBW = 10 Hz, Sweep: Auto.
4. “ \* ”, means this data is the worst emission level.
5. Measurement Level = Reading Level + Correct Factor.
6. The average measurement was not performed when the peak measured data under the limit of average detection.

Product : Intel® Dual Band Wireless-AC 8260  
 Test Item : Band Edge  
 Test Site : No.3 OATS  
 Test Mode : Mode 2 SISO B: Transmit (802.11b 1Mbps)

**RF Radiated Measurement (Horizontal):**

Channel No.	Frequency (MHz)	Correct Factor (dB)	Reading Level (dBuV)	Emission Level (dBuV/m)	Peak Limit (dBuV/m)	Average Limit (dBuV/m)	Result
09 (Peak)	2453.700	31.957	79.984	111.941	--	--	Pass
09 (Peak)	2483.500	32.182	38.895	71.077	74.00	54.00	Pass
09 (Average)	2451.300	31.938	74.706	106.644	--	--	Pass
09 (Average)	2483.500	32.182	21.251	53.433	74.00	54.00	Pass

**Figure Channel 09: Horizontal (Peak)**

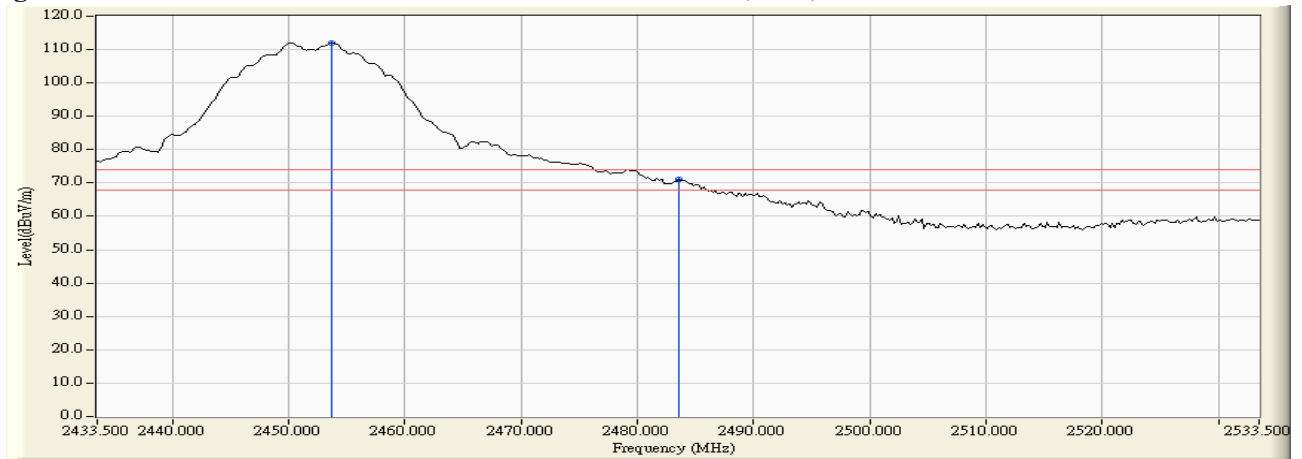

**Figure Channel 09: Horizontal (Average)**



Note:

1. All readings above 1GHz are performed with peak and/or average measurements as necessary.
2. Peak measurements: RBW = 1MHz, VBW = 3 MHz, Sweep: Auto.
3. Average measurements: RBW = 1MHz, VBW = 10 Hz, Sweep: Auto.
4. “ \* ”, means this data is the worst emission level.
5. Measurement Level = Reading Level + Correct Factor.
6. The average measurement was not performed when the peak measured data under the limit of average detection.

Product : Intel® Dual Band Wireless-AC 8260  
 Test Item : Band Edge  
 Test Site : No.3 OATS  
 Test Mode : Mode 2 SISO B: Transmit (802.11b 1Mbps)

**RF Radiated Measurement (Vertical):**

Channel No.	Frequency (MHz)	Correct Factor (dB)	Reading Level (dBuV)	Emission Level (dBuV/m)	Peak Limit (dBuV/m)	Average Limit (dBuV/m)	Result
09 (Peak)	2450.100	31.208	77.298	108.507	--	--	Pass
09 (Peak)	2483.500	31.435	35.537	66.972	74.00	54.00	Pass
09 (Average)	2451.300	31.217	72.093	103.310	--	--	Pass
09 (Average)	2483.500	31.435	18.795	50.230	74.00	54.00	Pass

**Figure Channel 09: Vertical (Peak)**

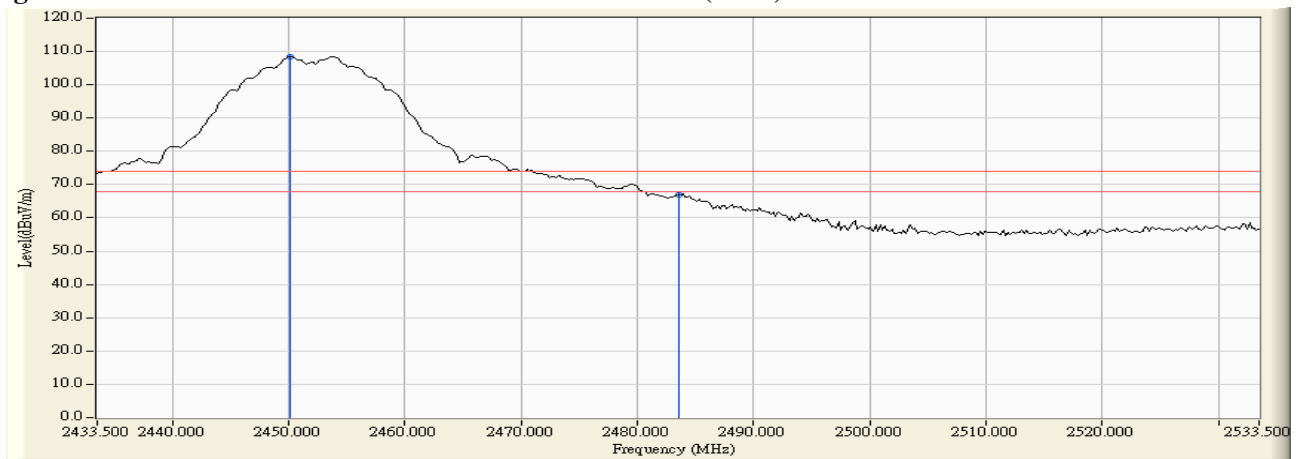

**Figure Channel 09: Vertical (Average)**





Note:

1. All readings above 1GHz are performed with peak and/or average measurements as necessary.
2. Peak measurements: RBW = 1MHz, VBW = 3 MHz, Sweep: Auto.
3. Average measurements: RBW = 1MHz, VBW = 10 Hz, Sweep: Auto.
4. “ \* ”, means this data is the worst emission level.
5. Measurement Level = Reading Level + Correct Factor.
6. The average measurement was not performed when the peak measured data under the limit of average detection.

Product : Intel® Dual Band Wireless-AC 8260  
 Test Item : Band Edge  
 Test Site : No.3 OATS  
 Test Mode : Mode 2 SISO B: Transmit (802.11b 1Mbps)

**RF Radiated Measurement (Horizontal):**

Channel No.	Frequency (MHz)	Correct Factor (dB)	Reading Level (dBuV)	Emission Level (dBuV/m)	Peak Limit (dBuV/m)	Average Limit (dBuV/m)	Result
10 (Peak)	2458.700	31.994	78.307	110.301	--	--	Pass
10 (Peak)	2483.500	32.182	38.438	70.620	74.00	54.00	Pass
10 (Average)	2456.300	31.976	73.144	105.120	--	--	Pass
10 (Average)	2483.500	32.182	20.836	53.018	74.00	54.00	Pass

**Figure Channel 10: Horizontal (Peak)**

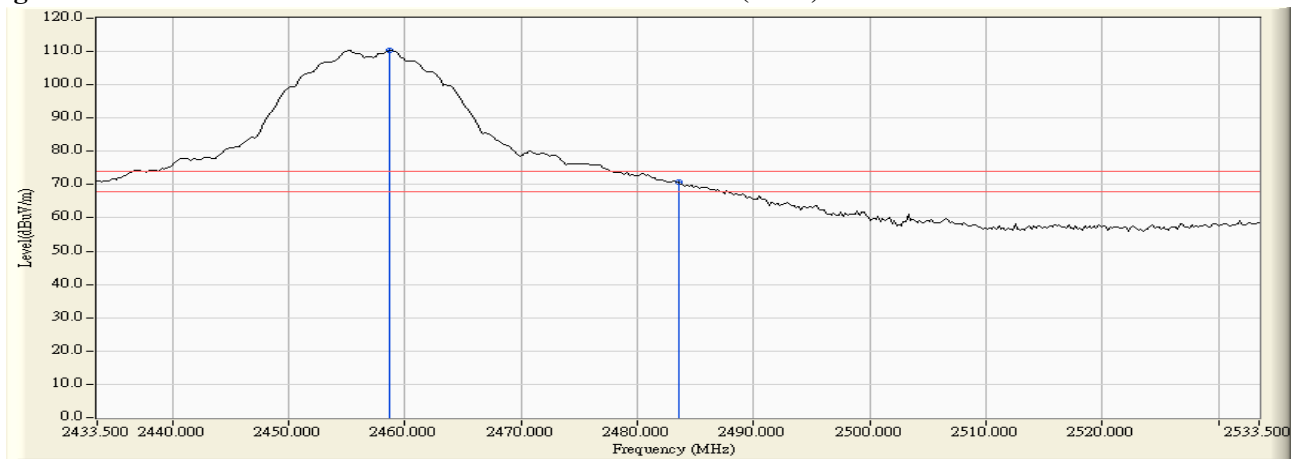

**Figure Channel 10: Horizontal (Average)**



Note:

1. All readings above 1GHz are performed with peak and/or average measurements as necessary.
2. Peak measurements: RBW = 1MHz, VBW = 3 MHz, Sweep: Auto.
3. Average measurements: RBW = 1MHz, VBW = 10 Hz, Sweep: Auto.
4. “ \* ”, means this data is the worst emission level.
5. Measurement Level = Reading Level + Correct Factor.
6. The average measurement was not performed when the peak measured data under the limit of average detection.

Product : Intel® Dual Band Wireless-AC 8260  
 Test Item : Band Edge  
 Test Site : No.3 OATS  
 Test Mode : Mode 2 SISO B: Transmit (802.11b 1Mbps)

**RF Radiated Measurement (Vertical):**

Channel No.	Frequency (MHz)	Correct Factor (dB)	Reading Level (dBuV)	Emission Level (dBuV/m)	Peak Limit (dBuV/m)	Average Limit (dBuV/m)	Result
10 (Peak)	2455.100	31.243	75.539	106.782	--	--	Pass
10 (Peak)	2483.500	31.435	35.079	66.514	74.00	54.00	Pass
10 (Average)	2456.300	31.251	70.302	101.553	--	--	Pass
10 (Average)	2483.500	31.435	18.235	49.670	74.00	54.00	Pass

**Figure Channel 10: Vertical (Peak)**

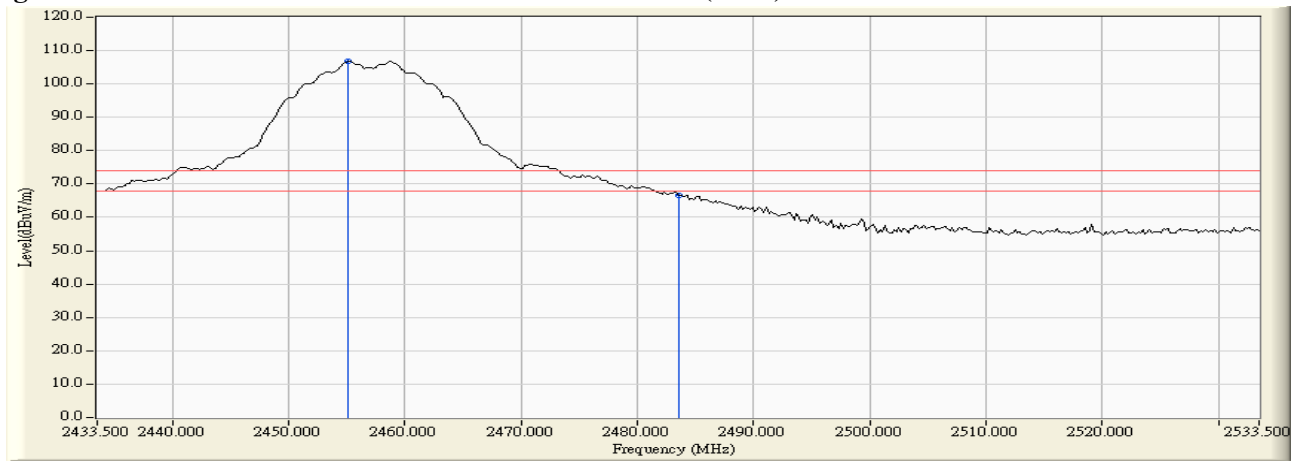

**Figure Channel 10: Vertical (Average)**



Note:

1. All readings above 1GHz are performed with peak and/or average measurements as necessary.
2. Peak measurements: RBW = 1MHz, VBW = 3 MHz, Sweep: Auto.
3. Average measurements: RBW = 1MHz, VBW = 10 Hz, Sweep: Auto.
4. “ \* ”, means this data is the worst emission level.
5. Measurement Level = Reading Level + Correct Factor.
6. The average measurement was not performed when the peak measured data under the limit of average detection.

Product : Intel® Dual Band Wireless-AC 8260  
 Test Item : Band Edge  
 Test Site : No.3 OATS  
 Test Mode : Mode 2 SISO B: Transmit (802.11b 1Mbps)

**RF Radiated Measurement (Horizontal):**

Channel No.	Frequency (MHz)	Correct Factor (dB)	Reading Level (dBuV)	Emission Level (dBuV/m)	Peak Limit (dBuV/m)	Average Limit (dBuV/m)	Result
11 (Peak)	2463.700	32.032	78.304	110.336	--	--	Pass
11 (Peak)	2483.500	32.182	40.470	72.652	74.00	54.00	Pass
11 (Peak)	2484.300	32.187	40.818	73.006	74.00	54.00	Pass
11 (Average)	2461.100	32.013	73.161	105.174	--	--	Pass
11 (Average)	2483.500	32.182	16.072	48.254	74.00	54.00	Pass
11 (Average)	2488.700	32.222	20.790	53.011	74.00	54.00	Pass

**Figure Channel 11: Horizontal (Peak)**

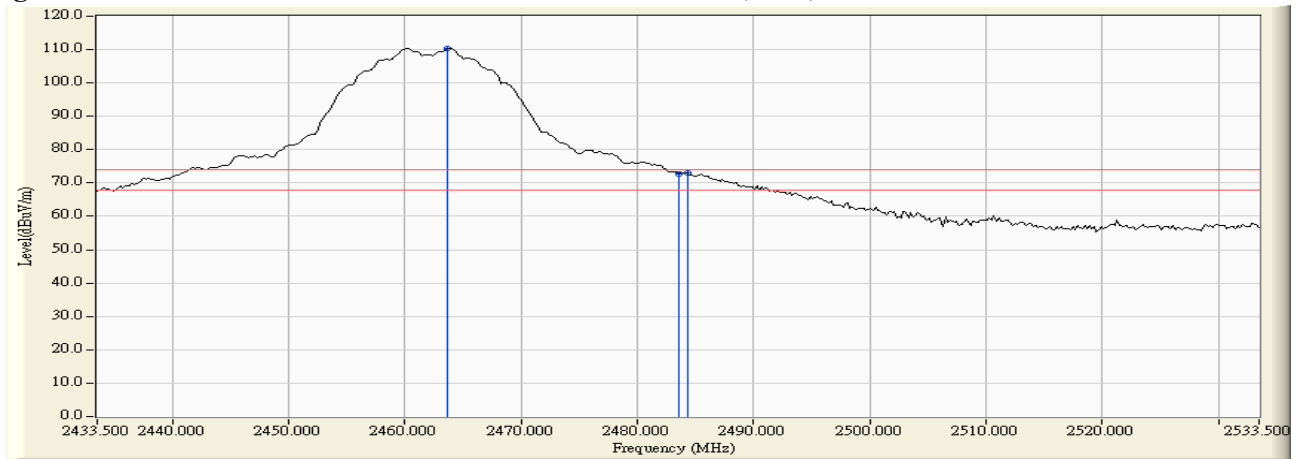

**Figure Channel 11: Horizontal (Average)**

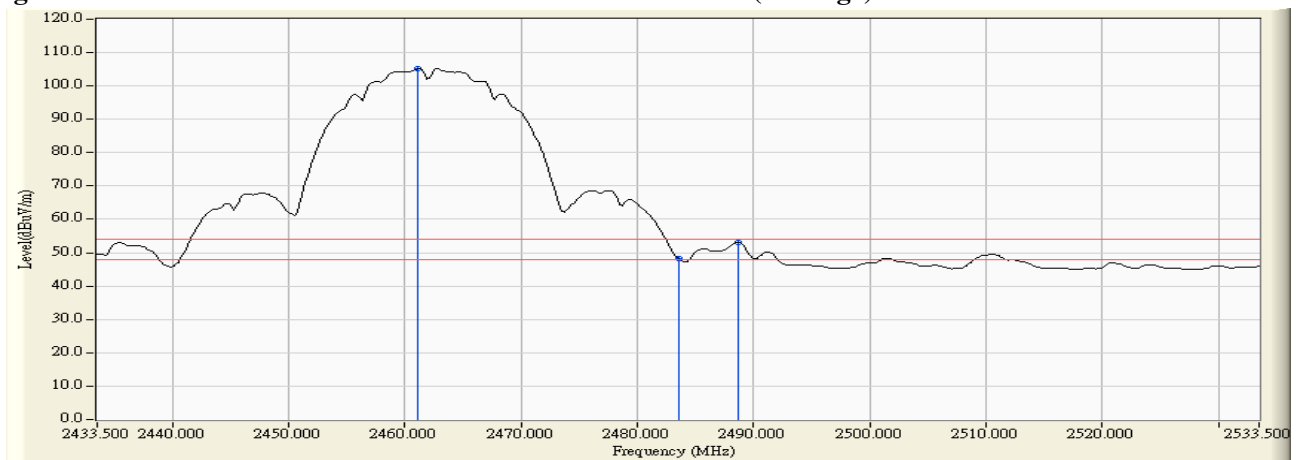

Note:

1. All readings above 1GHz are performed with peak and/or average measurements as necessary.
2. Peak measurements: RBW = 1MHz, VBW = 3 MHz, Sweep: Auto.
3. Average measurements: RBW = 1MHz, VBW = 10 Hz, Sweep: Auto.
4. “ \* ”, means this data is the worst emission level.
5. Measurement Level = Reading Level + Correct Factor.
6. The average measurement was not performed when the peak measured data under the limit of average detection.

Product : Intel® Dual Band Wireless-AC 8260  
 Test Item : Band Edge  
 Test Site : No.3 OATS  
 Test Mode : Mode 2 SISO B: Transmit (802.11b 1Mbps)

**RF Radiated Measurement (Vertical):**

Channel No.	Frequency (MHz)	Correct Factor (dB)	Reading Level (dBuV)	Emission Level (dBuV/m)	Peak Limit (dBuV/m)	Average Limit (dBuV/m)	Result
11 (Peak)	2460.100	31.277	75.540	106.817	--	--	Pass
11 (Peak)	2483.500	31.435	38.083	69.518	74.00	54.00	Pass
11 (Average)	2461.300	31.286	70.327	101.613	--	--	Pass
11 (Average)	2483.500	31.435	14.726	46.161	74.00	54.00	Pass
11 (Average)	2488.700	31.471	18.393	49.863	74.00	54.00	Pass

**Figure Channel 11: Vertical (Peak)**

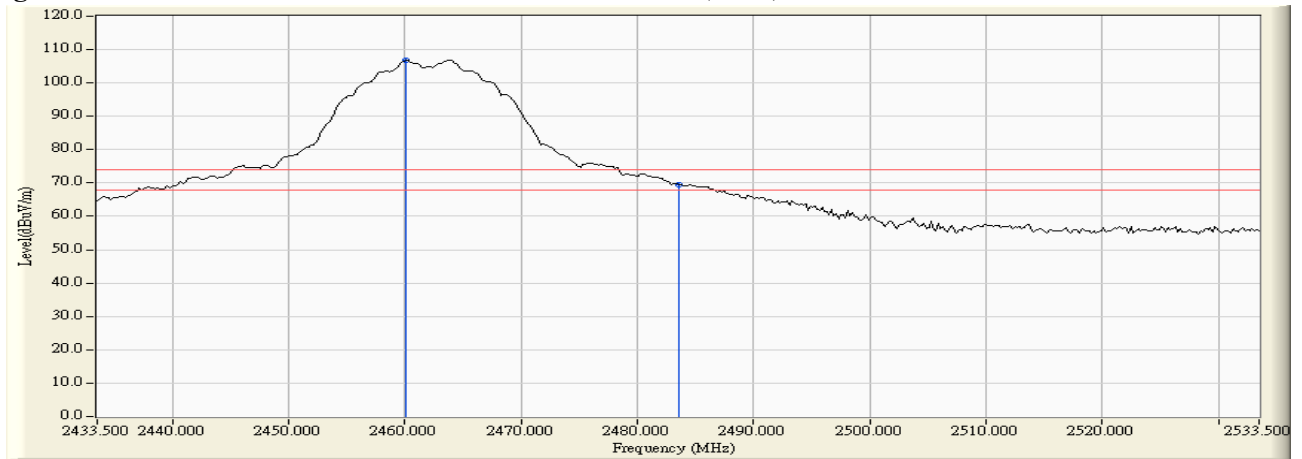

**Figure Channel 11: Vertical (Average)**

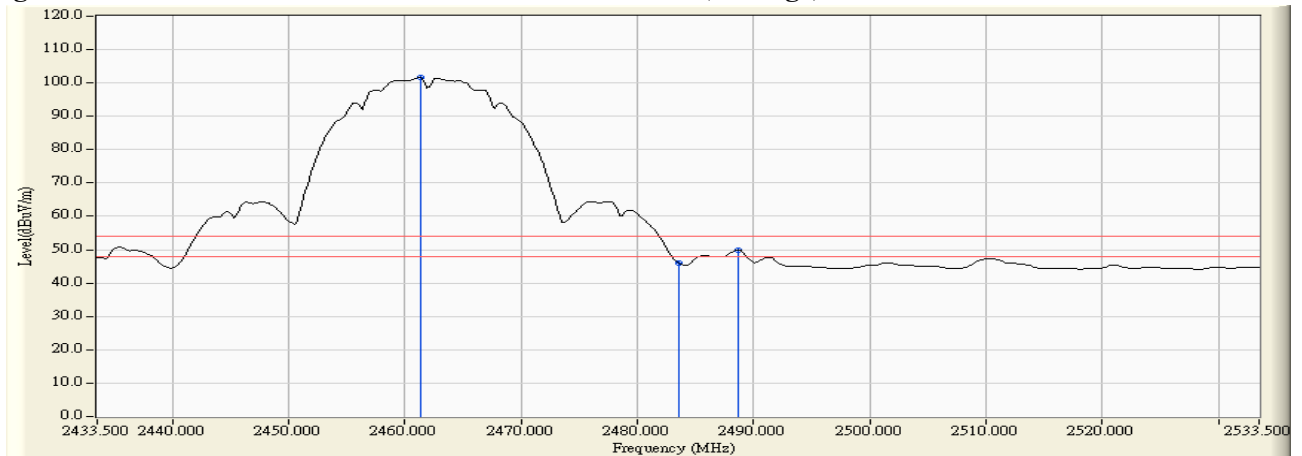



Note:

1. All readings above 1GHz are performed with peak and/or average measurements as necessary.
2. Peak measurements: RBW = 1MHz, VBW = 3 MHz, Sweep: Auto.
3. Average measurements: RBW = 1MHz, VBW = 10 Hz, Sweep: Auto.
4. “ \* ”, means this data is the worst emission level.
5. Measurement Level = Reading Level + Correct Factor.
6. The average measurement was not performed when the peak measured data under the limit of average detection.

Product : Intel® Dual Band Wireless-AC 8260  
 Test Item : Band Edge  
 Test Site : No.3 OATS  
 Test Mode : Mode 2 SISO B: Transmit (802.11b 1Mbps)

**RF Radiated Measurement (Horizontal):**

Channel No.	Frequency (MHz)	Correct Factor (dB)	Reading Level (dBuV)	Emission Level (dBuV/m)	Peak Limit (dBuV/m)	Average Limit (dBuV/m)	Result
12 (Peak)	2468.700	32.070	75.296	107.366	--	--	Pass
12 (Peak)	2483.500	32.182	41.515	73.697	74.00	54.00	Pass
12 (Average)	2466.300	32.052	70.106	102.158	--	--	Pass
12 (Average)	2483.500	32.182	21.243	53.425	74.00	54.00	Pass

**Figure Channel 12: Horizontal (Peak)**

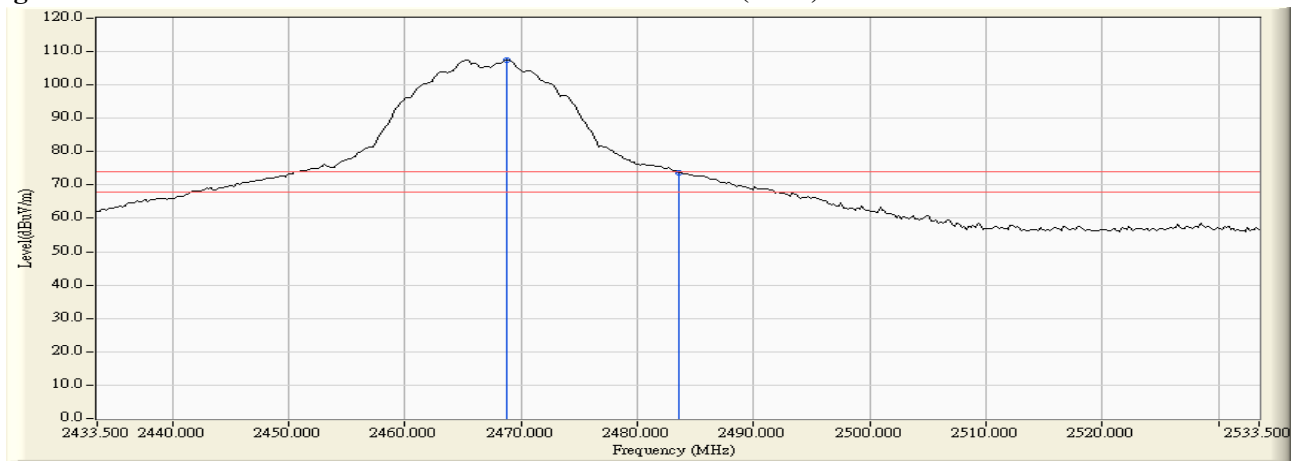

**Figure Channel 12: Horizontal (Average)**

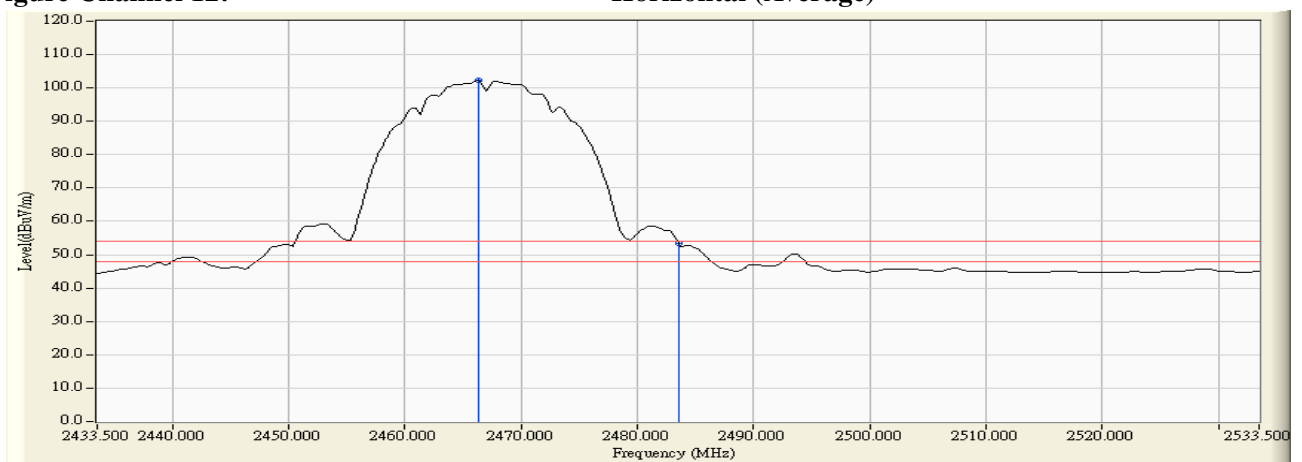

Note:

1. All readings above 1GHz are performed with peak and/or average measurements as necessary.
2. Peak measurements: RBW = 1MHz, VBW = 3 MHz, Sweep: Auto.
3. Average measurements: RBW = 1MHz, VBW = 10 Hz, Sweep: Auto.
4. “ \* ”, means this data is the worst emission level.
5. Measurement Level = Reading Level + Correct Factor.
6. The average measurement was not performed when the peak measured data under the limit of average detection.

Product : Intel® Dual Band Wireless-AC 8260  
 Test Item : Band Edge  
 Test Site : No.3 OATS  
 Test Mode : Mode 2 SISO B: Transmit (802.11b 1Mbps)

**RF Radiated Measurement (Vertical):**

Channel No.	Frequency (MHz)	Correct Factor (dB)	Reading Level (dBuV)	Emission Level (dBuV/m)	Peak Limit (dBuV/m)	Average Limit (dBuV/m)	Result
12 (Peak)	2465.100	31.312	72.256	103.567	--	--	Pass
12 (Peak)	2483.500	31.435	38.543	69.978	74.00	54.00	Pass
12 (Average)	2466.300	31.319	67.170	98.489	--	--	Pass
12 (Average)	2483.500	31.435	18.788	50.223	74.00	54.00	Pass

**Figure Channel 12: Vertical (Peak)**

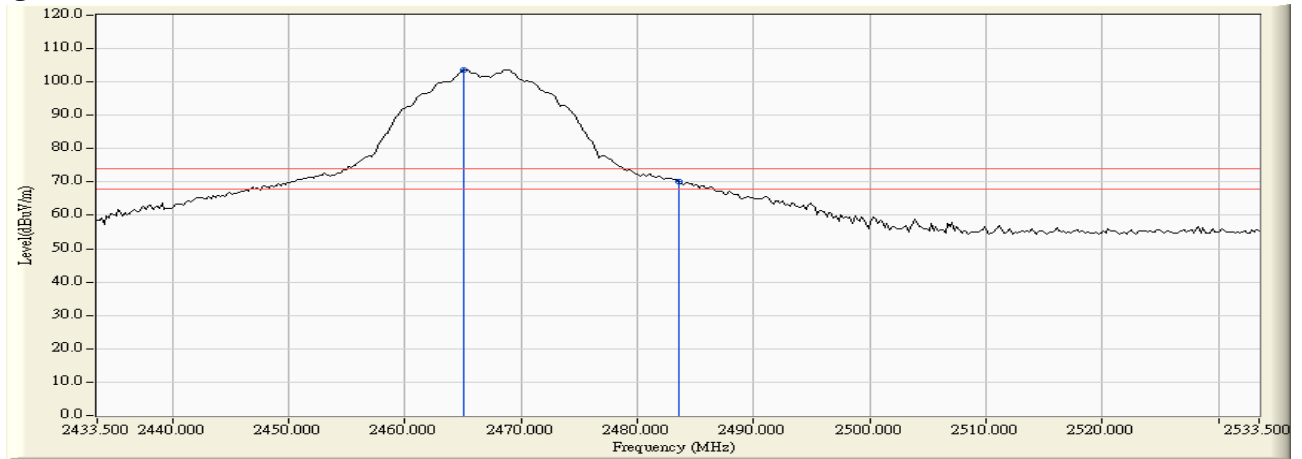

**Figure Channel 12: Vertical (Average)**

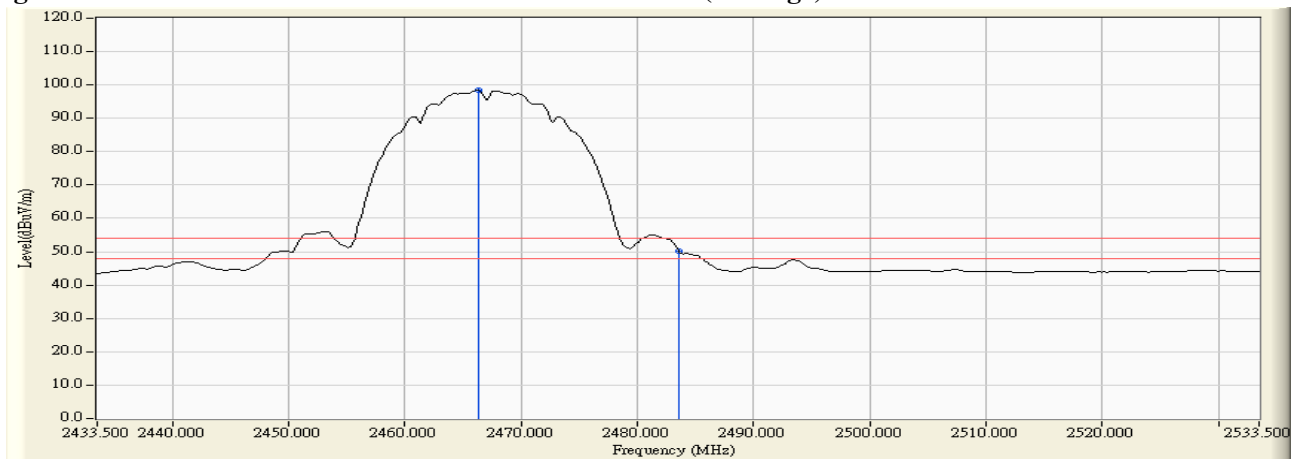

Note:

1. All readings above 1GHz are performed with peak and/or average measurements as necessary.
2. Peak measurements: RBW = 1MHz, VBW = 3 MHz, Sweep: Auto.
3. Average measurements: RBW = 1MHz, VBW = 10 Hz, Sweep: Auto.
4. “ \* ”, means this data is the worst emission level.
5. Measurement Level = Reading Level + Correct Factor.
6. The average measurement was not performed when the peak measured data under the limit of average detection.

Product : Intel® Dual Band Wireless-AC 8260  
 Test Item : Band Edge  
 Test Site : No.3 OATS  
 Test Mode : Mode 2 SISO B: Transmit (802.11g 6Mbps)

**RF Radiated Measurement (Horizontal):**

Channel No.	Frequency (MHz)	Correct Factor (dB)	Reading Level (dBuV)	Emission Level (dBuV/m)	Peak Limit (dBuV/m)	Average Limit (dBuV/m)	Result
01 (Peak)	2390.000	31.509	40.275	71.784	74.00	54.00	Pass
01 (Peak)	2400.000	31.561	56.873	88.434	74.00	54.00	Pass
01 (Peak)	2415.800	31.667	78.692	110.359	--	--	Pass
01 (Average)	2390.000	31.509	21.605	53.114	74.00	54.00	Pass
01 (Average)	2400.000	31.561	39.499	71.060	74.00	54.00	Pass
01 (Average)	2415.600	31.665	68.000	99.666	--	--	Pass

**Figure Channel 01: Horizontal (Peak)**

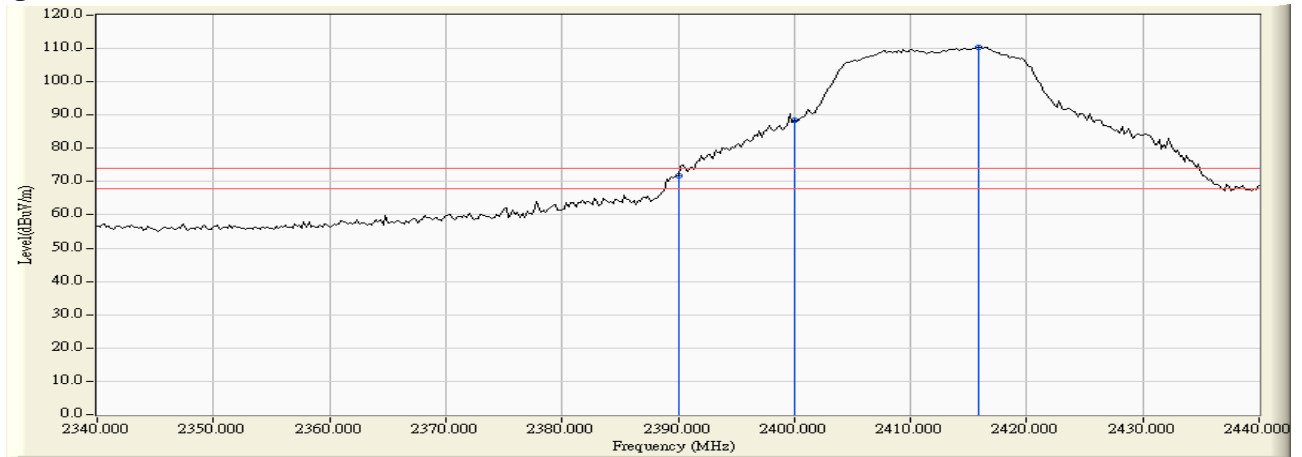

**Figure Channel 01: Horizontal (Average)**

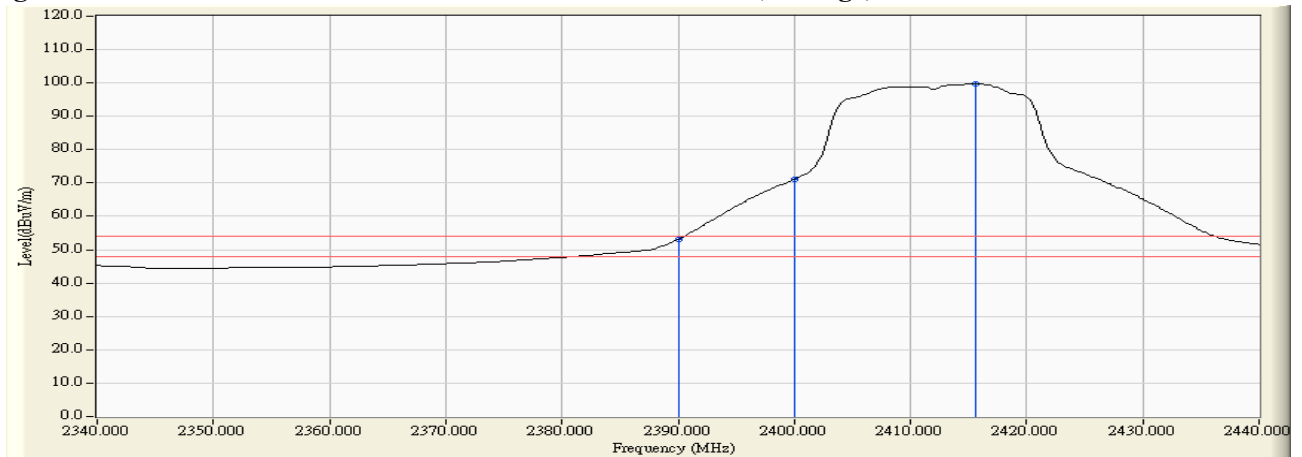

Note:

1. All readings above 1GHz are performed with peak and/or average measurements as necessary.
2. Peak measurements: RBW = 1MHz, VBW = 3 MHz, Sweep: Auto.
3. Average measurements: RBW = 1MHz, VBW = 10 Hz, Sweep: Auto.
4. “ \* ”, means this data is the worst emission level.
5. Measurement Level = Reading Level + Correct Factor.
6. The average measurement was not performed when the peak measured data under the limit of average detection.

Product : Intel® Dual Band Wireless-AC 8260  
 Test Item : Band Edge  
 Test Site : No.3 OATS  
 Test Mode : Mode 2 SISO B: Transmit (802.11g 6Mbps)

**RF Radiated Measurement (Vertical):**

Channel No.	Frequency (MHz)	Correct Factor (dB)	Reading Level (dBuV)	Emission Level (dBuV/m)	Peak Limit (dBuV/m)	Average Limit (dBuV/m)	Result
01 (Peak)	2390.000	30.915	40.359	71.274	74.00	54.00	Pass
01 (Peak)	2400.000	30.912	55.319	86.231	74.00	54.00	Pass
01 (Peak)	2408.800	30.937	77.095	108.031	--	--	Pass
01 (Average)	2390.000	30.915	21.624	52.539	74.00	54.00	Pass
01 (Average)	2400.000	30.912	39.017	69.929	74.00	54.00	Pass
01 (Average)	2415.800	30.975	66.437	97.412	--	--	Pass

**Figure Channel 01: Vertical (Peak)**

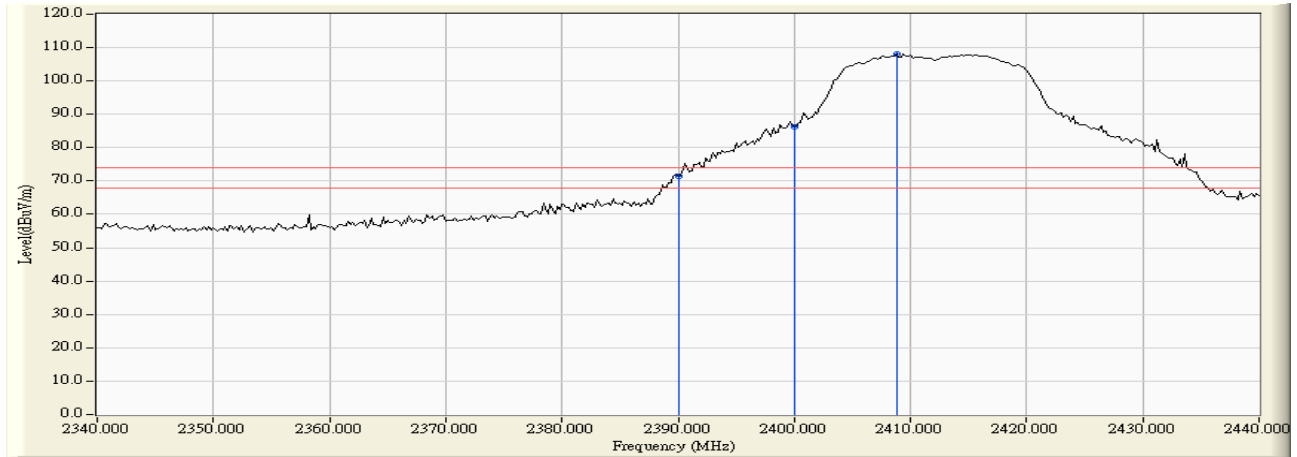

**Figure Channel 01: Vertical (Average)**

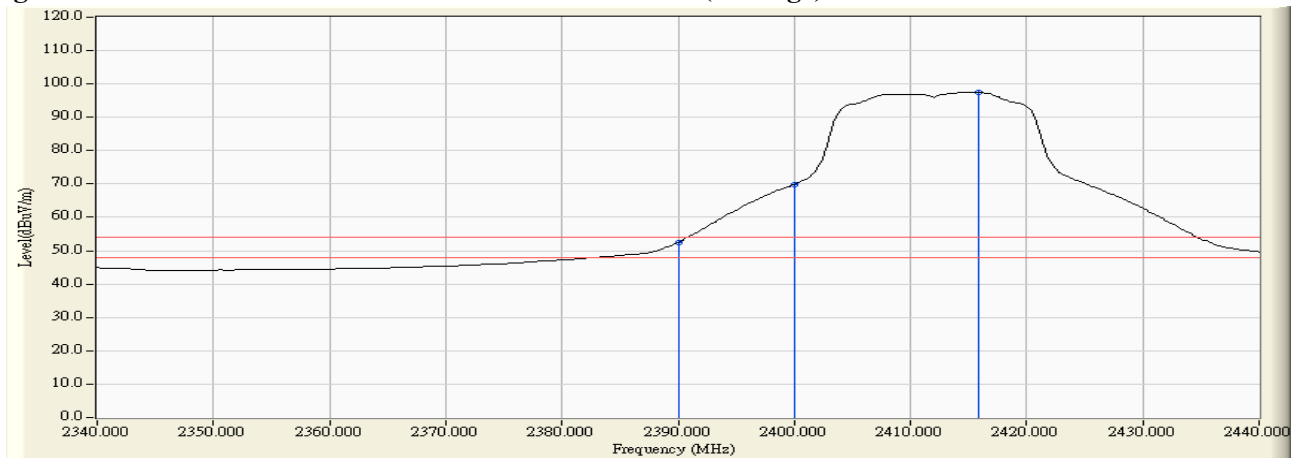



Note:

1. All readings above 1GHz are performed with peak and/or average measurements as necessary.
2. Peak measurements: RBW = 1MHz, VBW = 3 MHz, Sweep: Auto.
3. Average measurements: RBW = 1MHz, VBW = 10 Hz, Sweep: Auto.
4. “ \* ”, means this data is the worst emission level.
5. Measurement Level = Reading Level + Correct Factor.
6. The average measurement was not performed when the peak measured data under the limit of average detection.

Product : Intel® Dual Band Wireless-AC 8260  
 Test Item : Band Edge  
 Test Site : No.3 OATS  
 Test Mode : Mode 2 SISO B: Transmit (802.11g 6Mbps)

**RF Radiated Measurement (Horizontal):**

Channel No.	Frequency (MHz)	Correct Factor (dB)	Reading Level (dBuV)	Emission Level (dBuV/m)	Peak Limit (dBuV/m)	Average Limit (dBuV/m)	Result
11 (Peak)	2457.900	31.988	77.604	109.592	--	--	Pass
11 (Peak)	2483.500	32.182	36.556	68.738	74.00	54.00	Pass
11 (Peak)	2483.900	32.185	39.173	71.358	74.00	54.00	Pass
11 (Average)	2458.500	31.992	67.131	99.124	--	--	Pass
11 (Average)	2483.500	32.182	20.100	52.282	74.00	54.00	Pass

**Figure Channel 11: Horizontal (Peak)**

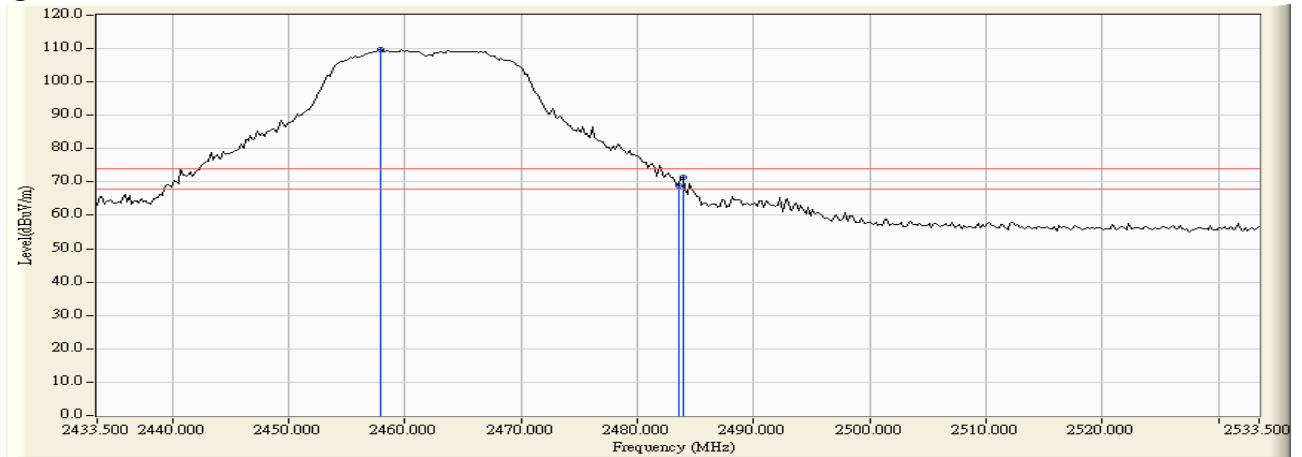

**Figure Channel 11: Horizontal (Average)**

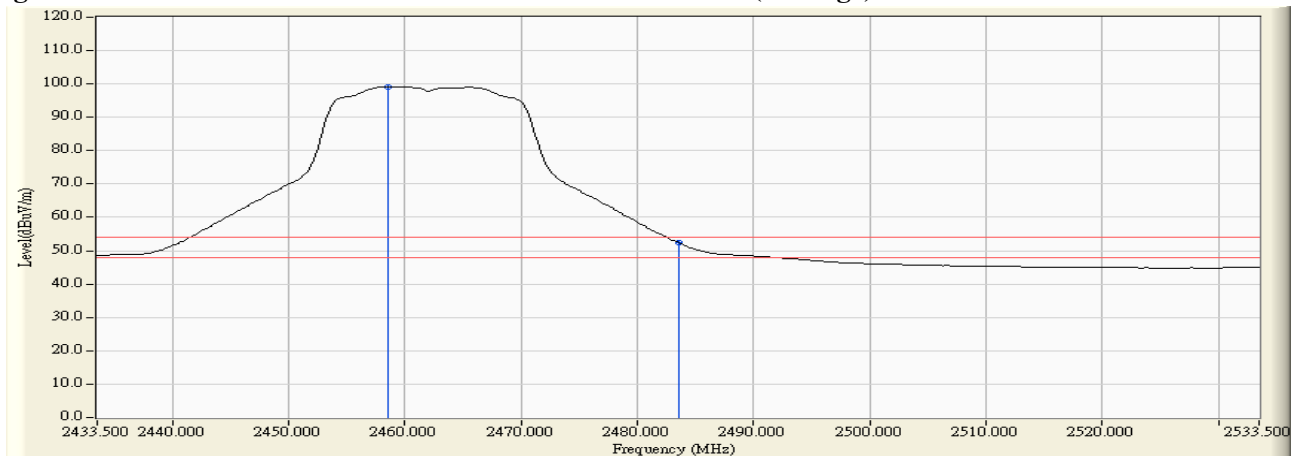

Note:

1. All readings above 1GHz are performed with peak and/or average measurements as necessary.
2. Peak measurements: RBW = 1MHz, VBW = 3 MHz, Sweep: Auto.
3. Average measurements: RBW = 1MHz, VBW = 10 Hz, Sweep: Auto.
4. “ \* ”, means this data is the worst emission level.
5. Measurement Level = Reading Level + Correct Factor.
6. The average measurement was not performed when the peak measured data under the limit of average detection.

Product : Intel® Dual Band Wireless-AC 8260  
 Test Item : Band Edge  
 Test Site : No.3 OATS  
 Test Mode : Mode 2 SISO B: Transmit (802.11g 6Mbps)

**RF Radiated Measurement (Vertical):**

Channel No.	Frequency (MHz)	Correct Factor (dB)	Reading Level (dBuV)	Emission Level (dBuV/m)	Peak Limit (dBuV/m)	Average Limit (dBuV/m)	Result
11 (Peak)	2463.900	31.303	76.861	108.164	--	--	Pass
11 (Peak)	2483.500	31.435	37.739	69.174	74.00	54.00	Pass
11 (Peak)	2484.100	31.439	38.421	69.860	74.00	54.00	Pass
11 (Average)	2465.700	31.315	66.458	97.773	--	--	Pass
11 (Average)	2483.500	31.435	19.906	51.341	74.00	54.00	Pass

**Figure Channel 11: Vertical (Peak)**

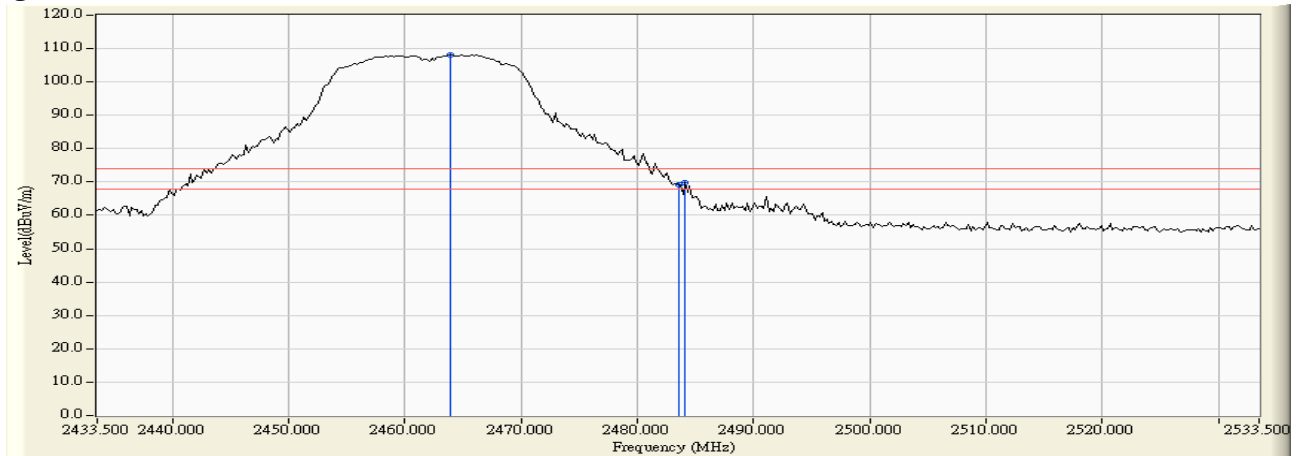

**Figure Channel 11: Vertical (Average)**

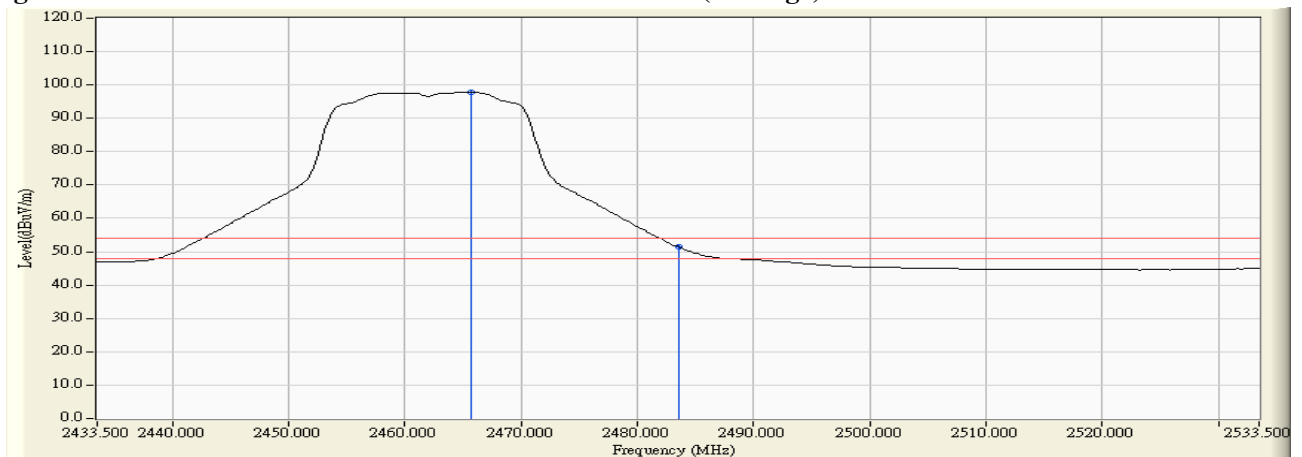

Note:

1. All readings above 1GHz are performed with peak and/or average measurements as necessary.
2. Peak measurements: RBW = 1MHz, VBW = 3 MHz, Sweep: Auto.
3. Average measurements: RBW = 1MHz, VBW = 10 Hz, Sweep: Auto.
4. “ \* ”, means this data is the worst emission level.
5. Measurement Level = Reading Level + Correct Factor.
6. The average measurement was not performed when the peak measured data under the limit of average detection.

Product : Intel® Dual Band Wireless-AC 8260  
 Test Item : Band Edge  
 Test Site : No.3 OATS  
 Test Mode : Mode 2 SISO B: Transmit (802.11g 6Mbps)

**RF Radiated Measurement (Horizontal):**

Channel No.	Frequency (MHz)	Correct Factor (dB)	Reading Level (dBuV)	Emission Level (dBuV/m)	Peak Limit (dBuV/m)	Average Limit (dBuV/m)	Result
12 (Peak)	2463.300	32.029	74.964	106.993	--	--	Pass
12 (Peak)	2483.500	32.182	38.542	70.724	74.00	54.00	Pass
12 (Average)	2468.500	32.068	64.451	96.519	--	--	Pass
12 (Average)	2483.500	32.182	20.013	52.195	74.00	54.00	Pass

**Figure Channel 12: Horizontal (Peak)**

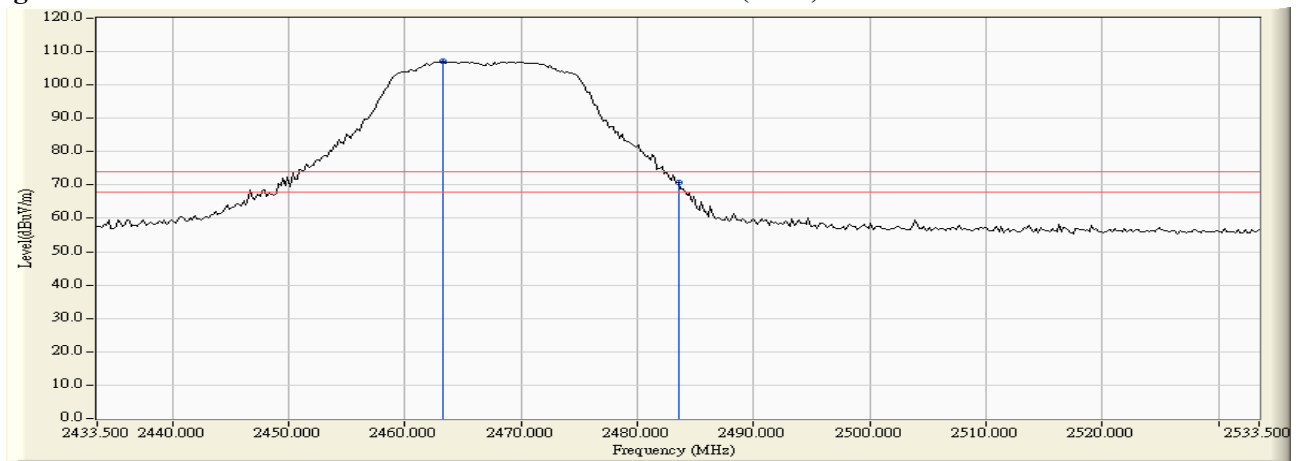

**Figure Channel 12: Horizontal (Average)**

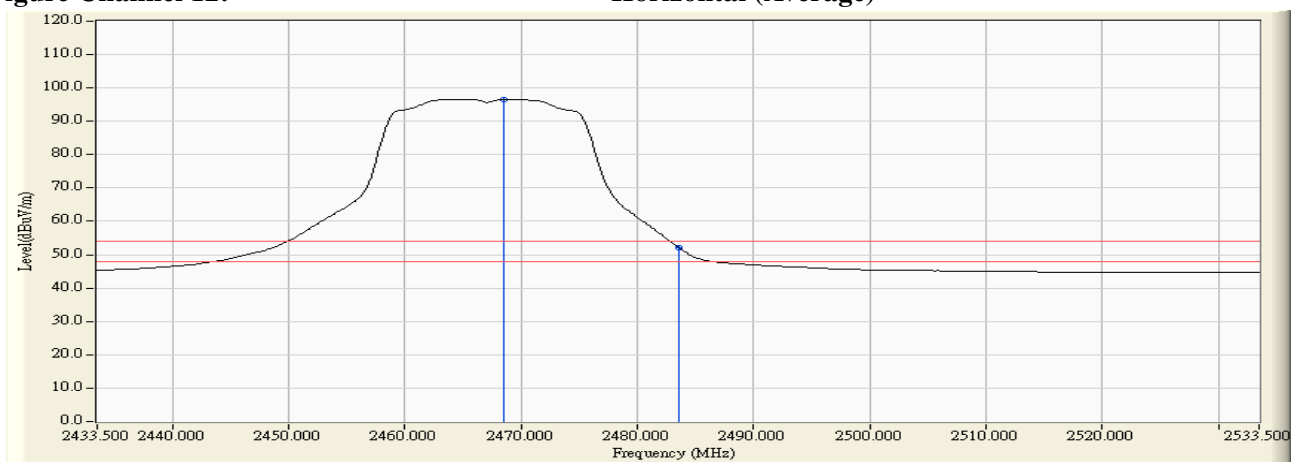

Note:

1. All readings above 1GHz are performed with peak and/or average measurements as necessary.
2. Peak measurements: RBW = 1MHz, VBW = 3 MHz, Sweep: Auto.
3. Average measurements: RBW = 1MHz, VBW = 10 Hz, Sweep: Auto.
4. “ \* ”, means this data is the worst emission level.
5. Measurement Level = Reading Level + Correct Factor.
6. The average measurement was not performed when the peak measured data under the limit of average detection.

Product : Intel® Dual Band Wireless-AC 8260  
 Test Item : Band Edge  
 Test Site : No.3 OATS  
 Test Mode : Mode 2 SISO B: Transmit (802.11g 6Mbps)

**RF Radiated Measurement (Vertical):**

Channel No.	Frequency (MHz)	Correct Factor (dB)	Reading Level (dBuV)	Emission Level (dBuV/m)	Peak Limit (dBuV/m)	Average Limit (dBuV/m)	Result
12 (Peak)	2470.700	31.349	74.746	106.095	--	--	Pass
12 (Peak)	2483.500	31.435	37.182	68.617	74.00	54.00	Pass
12 (Peak)	2483.900	31.438	38.344	69.782	74.00	54.00	Pass
12 (Average)	2468.700	31.336	64.014	95.349	--	--	Pass
12 (Average)	2483.500	31.435	19.717	51.152	74.00	54.00	Pass

**Figure Channel 12: Vertical (Peak)**

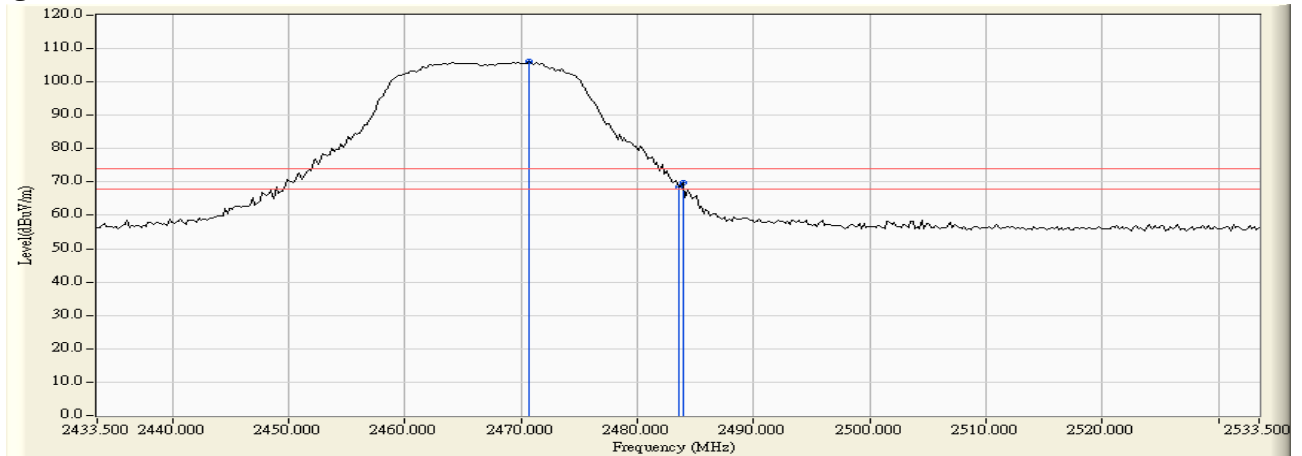

**Figure Channel 12: Vertical (Average)**

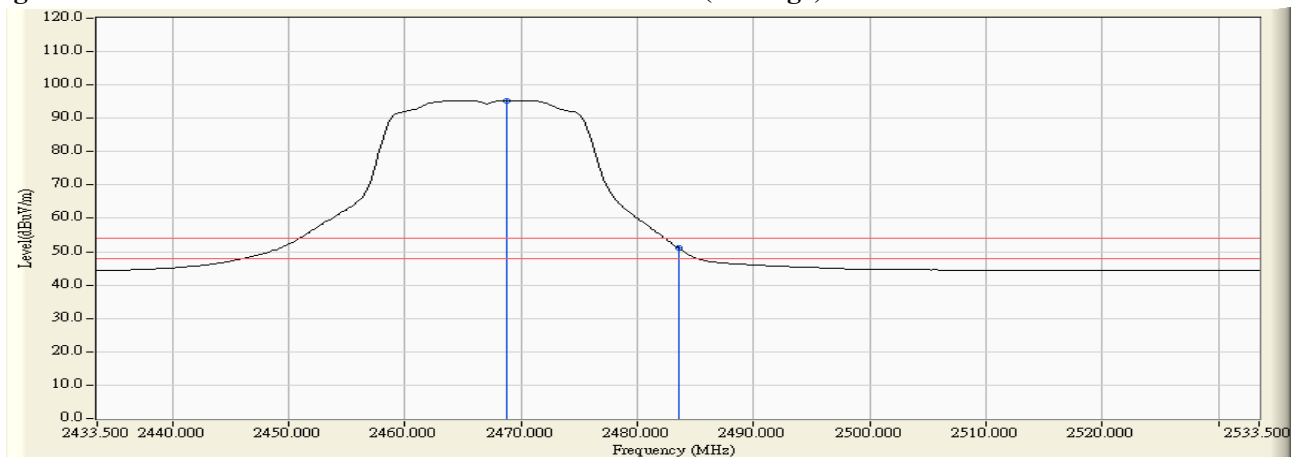



Note:

1. All readings above 1GHz are performed with peak and/or average measurements as necessary.
2. Peak measurements: RBW = 1MHz, VBW = 3 MHz, Sweep: Auto.
3. Average measurements: RBW = 1MHz, VBW = 10 Hz, Sweep: Auto.
4. “ \* ”, means this data is the worst emission level.
5. Measurement Level = Reading Level + Correct Factor.
6. The average measurement was not performed when the peak measured data under the limit of average detection.

Product : Intel® Dual Band Wireless-AC 8260  
 Test Item : Band Edge  
 Test Site : No.3 OATS  
 Test Mode : Mode 2 SISO B: Transmit - 802.11n-20BW\_7.2Mbps(2.4G Band)

**RF Radiated Measurement (Horizontal):**

Channel No.	Frequency (MHz)	Correct Factor (dB)	Reading Level (dBuV)	Emission Level (dBuV/m)	Peak Limit (dBuV/m)	Average Limit (dBuV/m)	Result
01 (Peak)	2390.000	31.509	41.753	73.262	74.00	54.00	Pass
01 (Peak)	2400.000	31.561	56.761	88.322	74.00	54.00	Pass
01 (Peak)	2414.800	31.660	79.517	111.177	--	--	Pass
01 (Average)	2390.000	31.509	21.453	52.962	74.00	54.00	Pass
01 (Average)	2400.000	31.561	38.684	70.245	74.00	54.00	Pass
01 (Average)	2415.600	31.665	68.363	100.029	--	--	Pass

**Figure Channel 01:**

**Horizontal (Peak)**

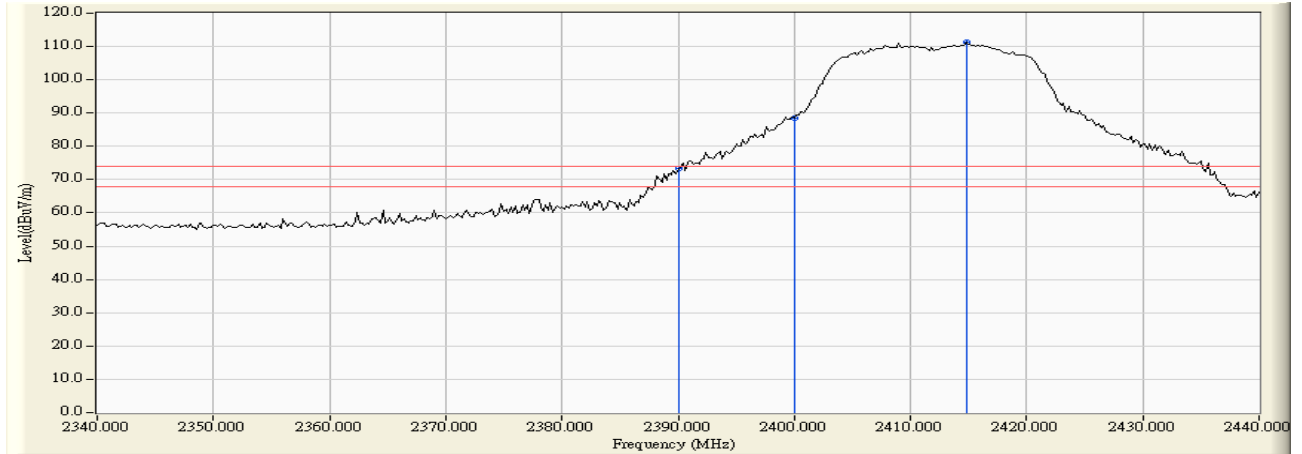

**Figure Channel 01:**

**Horizontal (Average)**

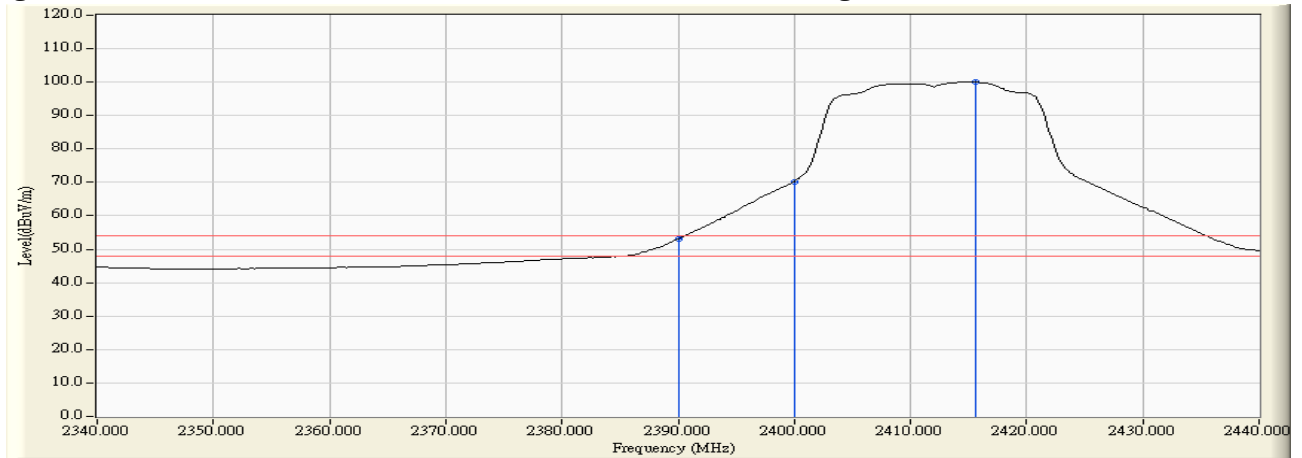

Note:

1. All readings above 1GHz are performed with peak and/or average measurements as necessary.
2. Peak measurements: RBW = 1MHz, VBW = 3 MHz, Sweep: Auto.
3. Average measurements: RBW = 1MHz, VBW = 10 Hz, Sweep: Auto.
4. “ \* ”, means this data is the worst emission level.
5. Measurement Level = Reading Level + Correct Factor.
6. The average measurement was not performed when the peak measured data under the limit of average detection.

Product : Intel® Dual Band Wireless-AC 8260  
 Test Item : Band Edge  
 Test Site : No.3 OATS  
 Test Mode : Mode 2 SISO B: Transmit - 802.11n-20BW\_7.2Mbps(2.4G Band)

**RF Radiated Measurement (Vertical):**

Channel No.	Frequency (MHz)	Correct Factor (dB)	Reading Level (dBuV)	Emission Level (dBuV/m)	Peak Limit (dBuV/m)	Average Limit (dBuV/m)	Result
01 (Peak)	2390.000	30.915	38.950	69.865	74.00	54.00	Pass
01 (Peak)	2400.000	30.912	55.313	86.225	74.00	54.00	Pass
01 (Peak)	2410.400	30.941	76.813	107.754	--	--	Pass
01 (Average)	2390.000	30.915	19.865	50.780	74.00	54.00	Pass
01 (Average)	2400.000	30.912	36.402	67.314	74.00	54.00	Pass
01 (Average)	2414.800	30.968	65.522	96.490	--	--	Pass

**Figure Channel 01: Vertical (Peak)**

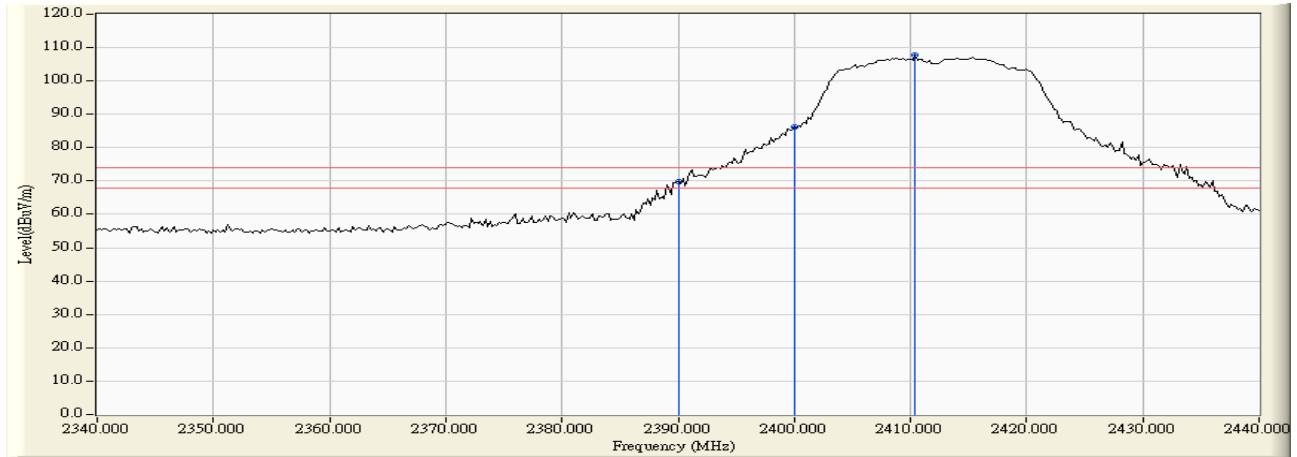

**Figure Channel 01: Vertical (Average)**

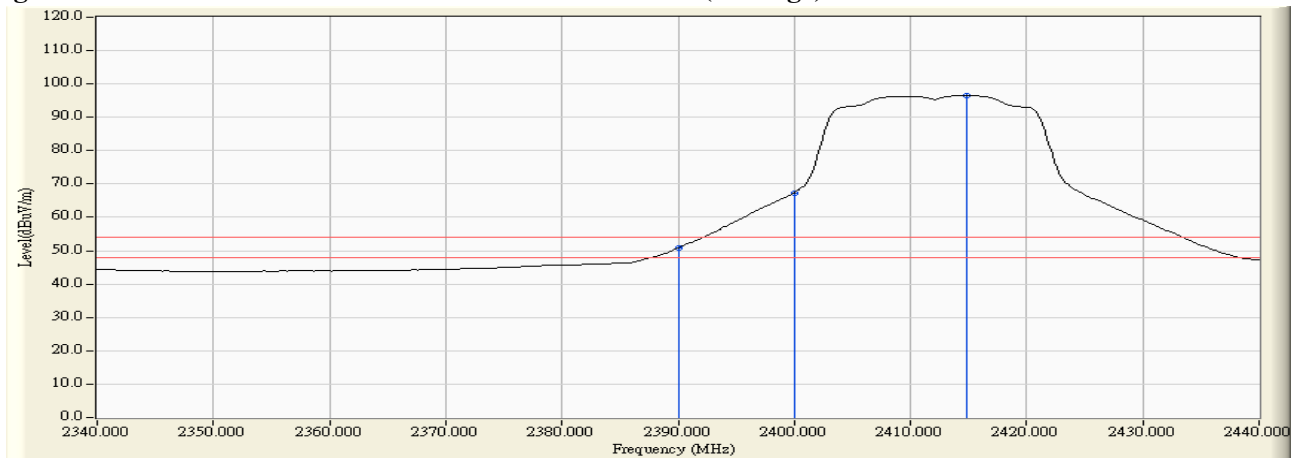

Note:

1. All readings above 1GHz are performed with peak and/or average measurements as necessary.
2. Peak measurements: RBW = 1MHz, VBW = 3 MHz, Sweep: Auto.
3. Average measurements: RBW = 1MHz, VBW = 10 Hz, Sweep: Auto.
4. “ \* ”, means this data is the worst emission level.
5. Measurement Level = Reading Level + Correct Factor.
6. The average measurement was not performed when the peak measured data under the limit of average detection.

Product : Intel® Dual Band Wireless-AC 8260  
 Test Item : Band Edge  
 Test Site : No.3 OATS  
 Test Mode : Mode 2 SISO B: Transmit - 802.11n-20BW\_7.2Mbps(2.4G Band)

**RF Radiated Measurement (Horizontal):**

Channel No.	Frequency (MHz)	Correct Factor (dB)	Reading Level (dBuV)	Emission Level (dBuV/m)	Peak Limit (dBuV/m)	Average Limit (dBuV/m)	Result
11 (Peak)	2460.100	32.005	78.908	110.913	--	--	Pass
11 (Peak)	2483.500	32.182	38.364	70.546	74.00	54.00	Pass
11 (Peak)	2483.700	32.183	40.670	72.854	74.00	54.00	Pass
11 (Average)	2458.500	31.992	67.609	99.602	--	--	Pass
11 (Average)	2483.500	32.182	20.392	52.574	74.00	54.00	Pass

**Figure Channel 11: Horizontal (Peak)**

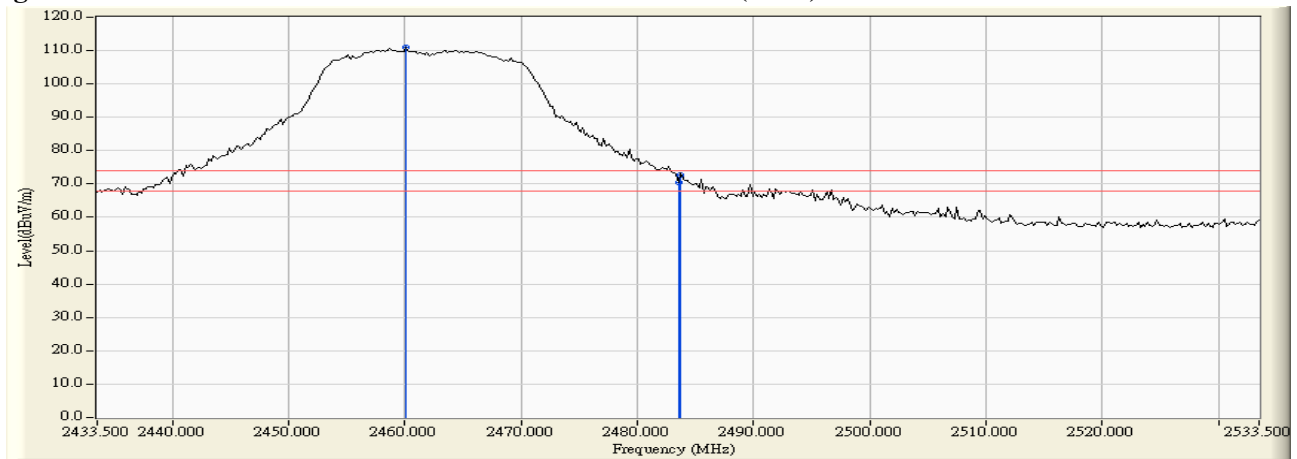

**Figure Channel 11: Horizontal (Average)**

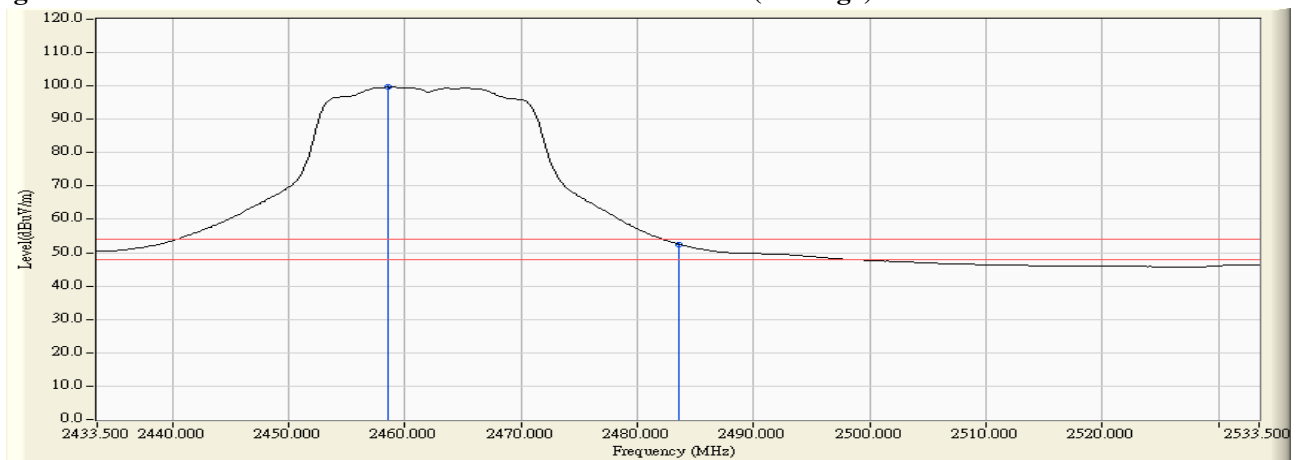

Note:

1. All readings above 1GHz are performed with peak and/or average measurements as necessary.
2. Peak measurements: RBW = 1MHz, VBW = 3 MHz, Sweep: Auto.
3. Average measurements: RBW = 1MHz, VBW = 10 Hz, Sweep: Auto.
4. “ \* ”, means this data is the worst emission level.
5. Measurement Level = Reading Level + Correct Factor.
6. The average measurement was not performed when the peak measured data under the limit of average detection.

Product : Intel® Dual Band Wireless-AC 8260  
 Test Item : Band Edge  
 Test Site : No.3 OATS  
 Test Mode : Mode 2 SISO B: Transmit - 802.11n-20BW\_7.2Mbps(2.4G Band)

**RF Radiated Measurement (Vertical):**

Channel No.	Frequency (MHz)	Correct Factor (dB)	Reading Level (dBuV)	Emission Level (dBuV/m)	Peak Limit (dBuV/m)	Average Limit (dBuV/m)	Result
11 (Peak)	2463.500	31.300	75.258	106.558	--	--	Pass
11 (Peak)	2483.500	31.435	36.238	67.673	74.00	54.00	Pass
11 (Peak)	2484.300	31.440	38.408	69.849	74.00	54.00	Pass
11 (Average)	2465.900	31.317	64.617	95.934	--	--	Pass
11 (Average)	2483.500	31.435	18.639	50.074	74.00	54.00	Pass

**Figure Channel 11: Vertical (Peak)**

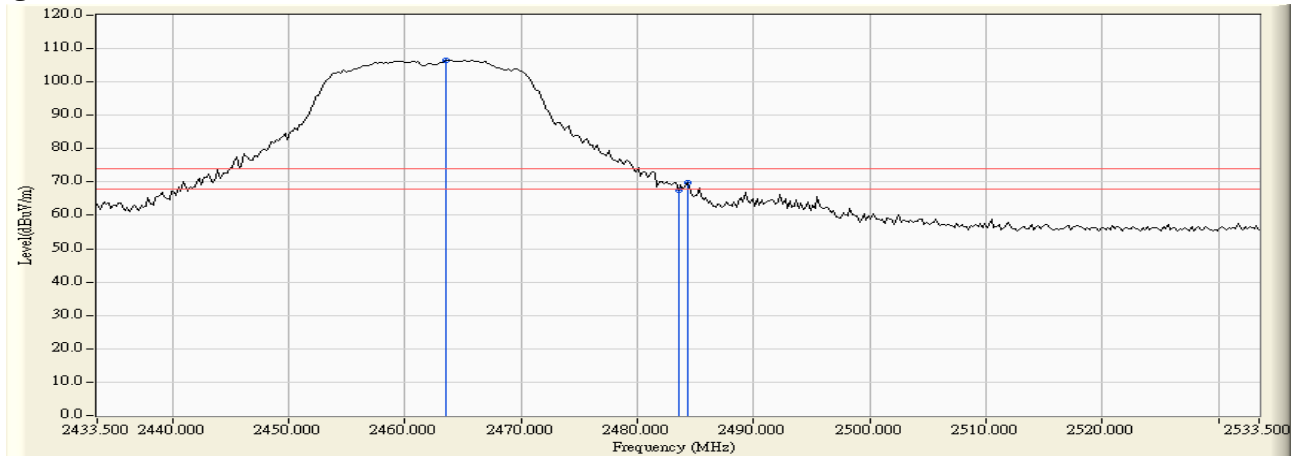

**Figure Channel 11: Vertical (Average)**

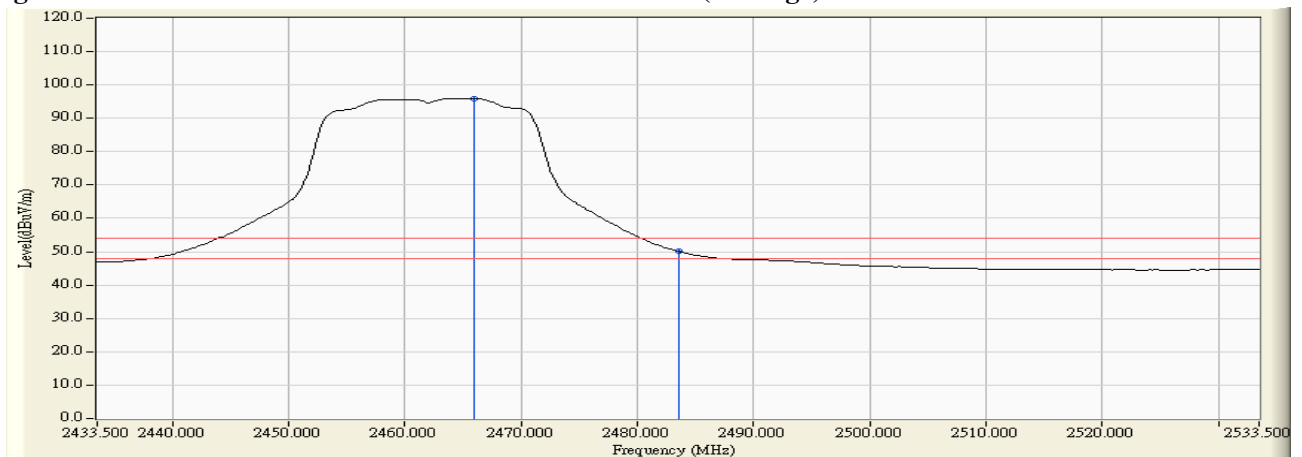



Note:

1. All readings above 1GHz are performed with peak and/or average measurements as necessary.
2. Peak measurements: RBW = 1MHz, VBW = 3 MHz, Sweep: Auto.
3. Average measurements: RBW = 1MHz, VBW = 10 Hz, Sweep: Auto.
4. “ \* ”, means this data is the worst emission level.
5. Measurement Level = Reading Level + Correct Factor.
6. The average measurement was not performed when the peak measured data under the limit of average detection.

Product : Intel® Dual Band Wireless-AC 8260  
 Test Item : Band Edge  
 Test Site : No.3 OATS  
 Test Mode : Mode 2 SISO B: Transmit - 802.11n-20BW\_7.2Mbps(2.4G Band)

**RF Radiated Measurement (Horizontal):**

Channel No.	Frequency (MHz)	Correct Factor (dB)	Reading Level (dBuV)	Emission Level (dBuV/m)	Peak Limit (dBuV/m)	Average Limit (dBuV/m)	Result
12 (Peak)	2465.300	32.044	75.320	107.364	--	--	Pass
12 (Peak)	2483.500	32.182	39.235	71.417	74.00	54.00	Pass
12 (Average)	2469.900	32.079	63.881	95.960	--	--	Pass
12 (Average)	2483.500	32.182	21.237	53.419	74.00	54.00	Pass

**Figure Channel 12: Horizontal (Peak)**

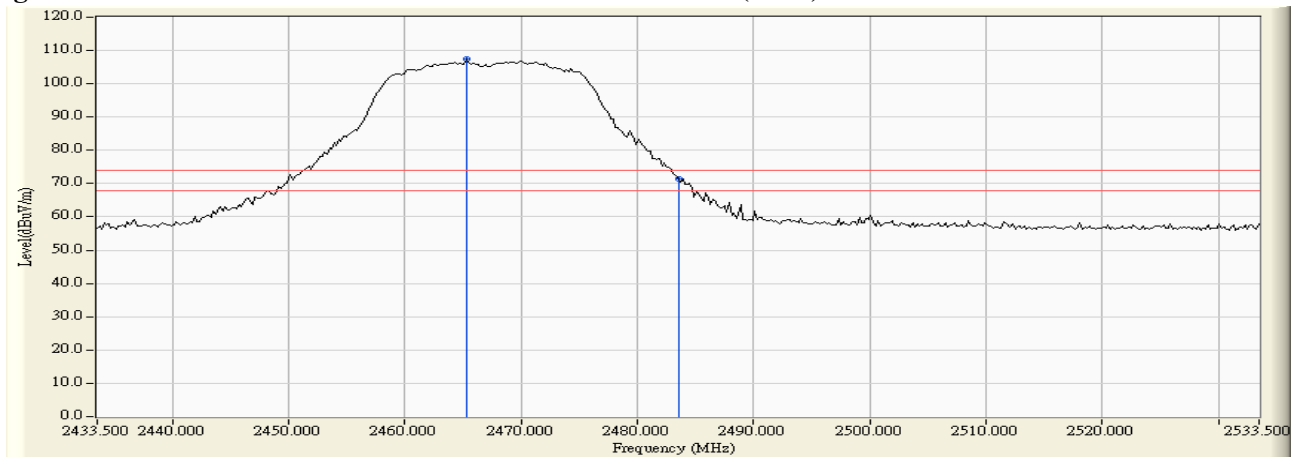

**Figure Channel 12: Horizontal (Average)**

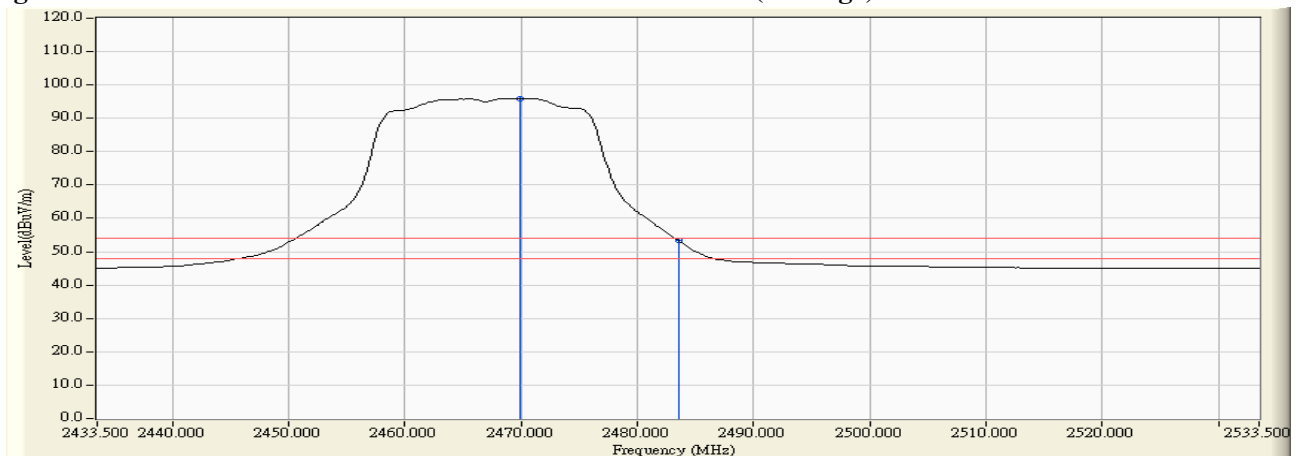

Note:

1. All readings above 1GHz are performed with peak and/or average measurements as necessary.
2. Peak measurements: RBW = 1MHz, VBW = 3 MHz, Sweep: Auto.
3. Average measurements: RBW = 1MHz, VBW = 10 Hz, Sweep: Auto.
4. “ \* ”, means this data is the worst emission level.
5. Measurement Level = Reading Level + Correct Factor.
6. The average measurement was not performed when the peak measured data under the limit of average detection.

Product : Intel® Dual Band Wireless-AC 8260  
 Test Item : Band Edge  
 Test Site : No.3 OATS  
 Test Mode : Mode 2 SISO B: Transmit - 802.11n-20BW\_7.2Mbps(2.4G Band)

**RF Radiated Measurement (Vertical):**

Channel No.	Frequency (MHz)	Correct Factor (dB)	Reading Level (dBuV)	Emission Level (dBuV/m)	Peak Limit (dBuV/m)	Average Limit (dBuV/m)	Result
12 (Peak)	2468.900	31.337	72.097	103.434	--	--	Pass
12 (Peak)	2483.500	31.435	36.235	67.670	74.00	54.00	Pass
12 (Average)	2470.300	31.346	61.609	92.955	--	--	Pass
12 (Average)	2483.500	31.435	18.927	50.362	74.00	54.00	Pass

**Figure Channel 12: Vertical (Peak)**

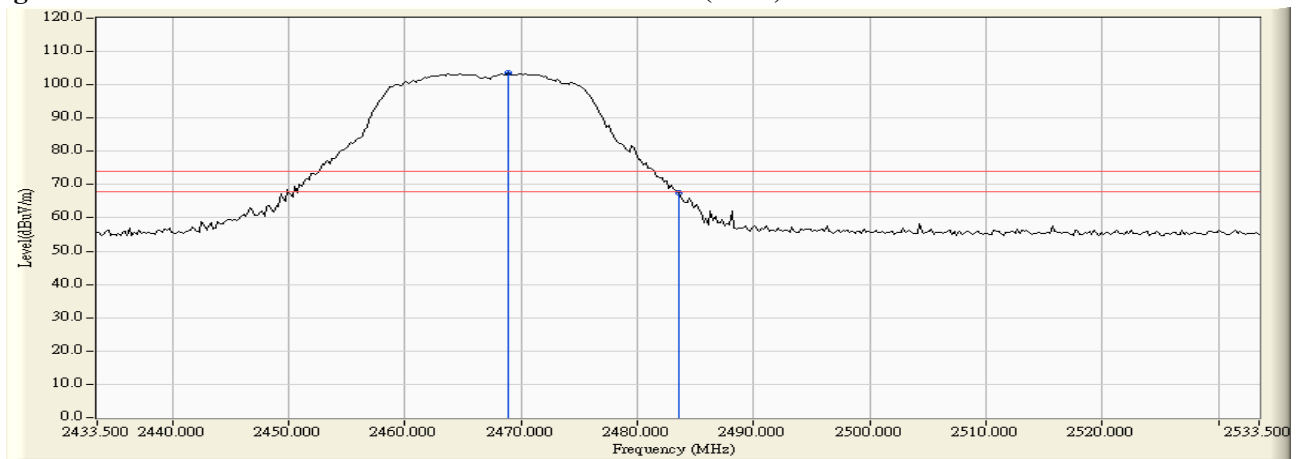

**Figure Channel 12: Vertical (Average)**

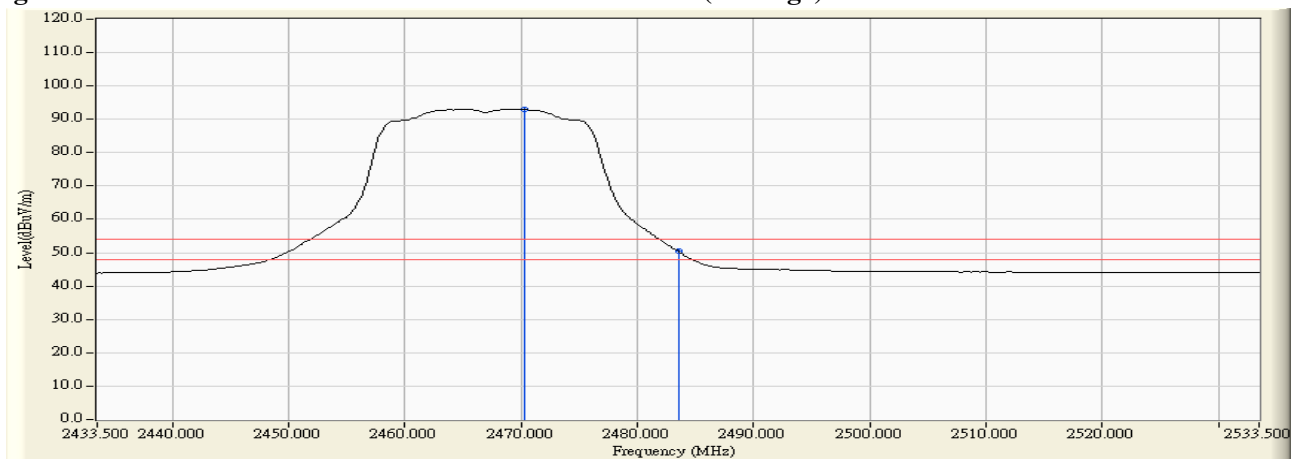

Note:

1. All readings above 1GHz are performed with peak and/or average measurements as necessary.
2. Peak measurements: RBW = 1MHz, VBW = 3 MHz, Sweep: Auto.
3. Average measurements: RBW = 1MHz, VBW = 10 Hz, Sweep: Auto.
4. “ \* ”, means this data is the worst emission level.
5. Measurement Level = Reading Level + Correct Factor.
6. The average measurement was not performed when the peak measured data under the limit of average detection.

Product : Intel® Dual Band Wireless-AC 8260  
 Test Item : Band Edge  
 Test Site : No.3 OATS  
 Test Mode : Mode 2 SISO B: Transmit - 802.11n-40BW\_15Mbps(2.4G Band)

**RF Radiated Measurement (Horizontal):**

Channel No.	Frequency (MHz)	Correct Factor (dB)	Reading Level (dBuV)	Emission Level (dBuV/m)	Peak Limit (dBuV/m)	Average Limit (dBuV/m)	Result
03 (Peak)	2389.200	31.506	35.762	67.268	74.00	54.00	Pass
03 (Peak)	2390.000	31.509	35.266	66.775	74.00	54.00	Pass
03 (Peak)	2400.000	31.561	49.142	80.703	74.00	54.00	Pass
03 (Peak)	2432.200	31.792	73.900	105.693	--	--	Pass
03 (Average)	2390.000	31.509	22.294	53.803	74.00	54.00	Pass
03 (Average)	2400.000	31.561	35.791	67.352	74.00	54.00	Pass
03 (Average)	2433.400	31.802	62.223	94.025	--	--	Pass

**Figure Channel 03: Horizontal (Peak)**

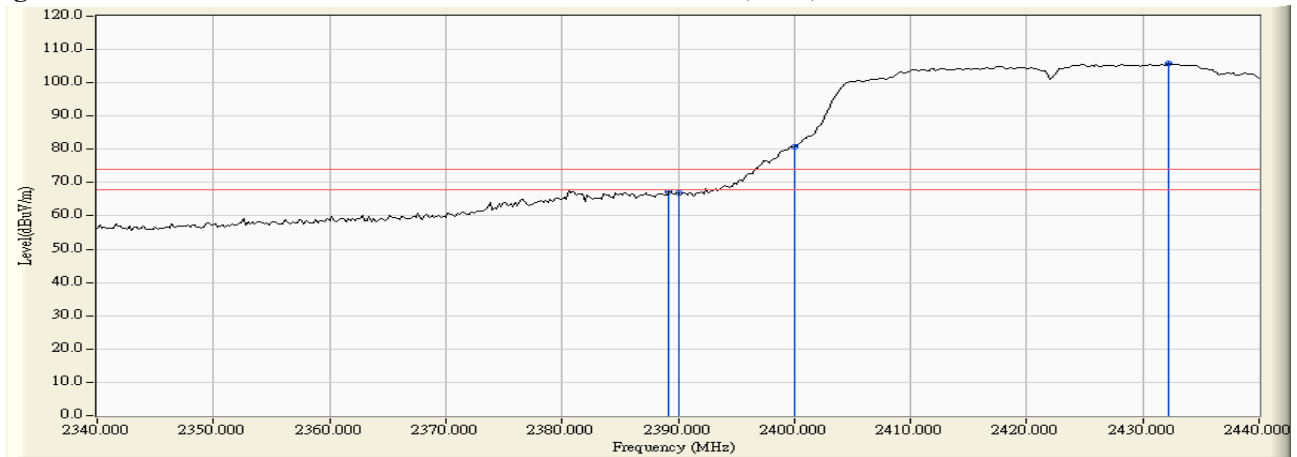

**Figure Channel 03: Horizontal (Average)**

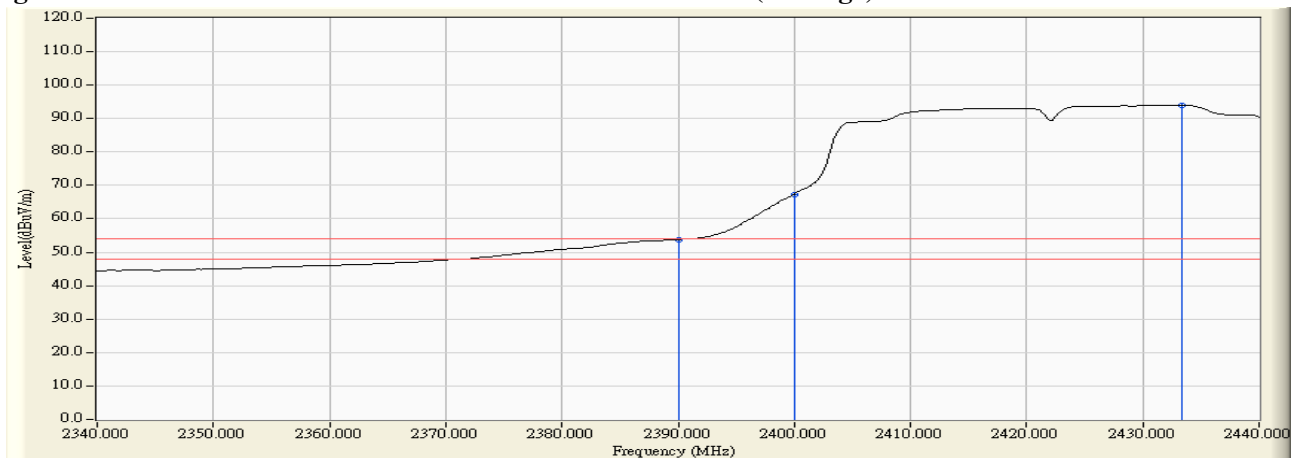

Note:

1. All readings above 1GHz are performed with peak and/or average measurements as necessary.
2. Peak measurements: RBW = 1MHz, VBW = 3 MHz, Sweep: Auto.
3. Average measurements: RBW = 1MHz, VBW = 10 Hz, Sweep: Auto.
4. “ \* ”, means this data is the worst emission level.
5. Measurement Level = Reading Level + Correct Factor.
6. The average measurement was not performed when the peak measured data under the limit of average detection.

Product : Intel® Dual Band Wireless-AC 8260  
 Test Item : Band Edge  
 Test Site : No.3 OATS  
 Test Mode : Mode 2 SISO B: Transmit - 802.11n-40BW\_15Mbps(2.4G Band)

**RF Radiated Measurement (Vertical):**

Channel No.	Frequency (MHz)	Correct Factor (dB)	Reading Level (dBuV)	Emission Level (dBuV/m)	Peak Limit (dBuV/m)	Average Limit (dBuV/m)	Result
03 (Peak)	2389.600	30.917	35.622	66.539	74.00	54.00	Pass
03 (Peak)	2390.000	30.915	34.172	65.087	74.00	54.00	Pass
03 (Peak)	2400.000	30.912	48.678	79.590	74.00	54.00	Pass
03 (Peak)	2424.800	31.036	72.414	103.450	--	--	Pass
03 (Average)	2390.000	30.915	21.221	52.136	74.00	54.00	Pass
03 (Average)	2400.000	30.912	34.768	65.680	74.00	54.00	Pass
03 (Average)	2433.400	31.094	60.701	91.796	--	--	Pass

**Figure Channel 03: Vertical (Peak)**

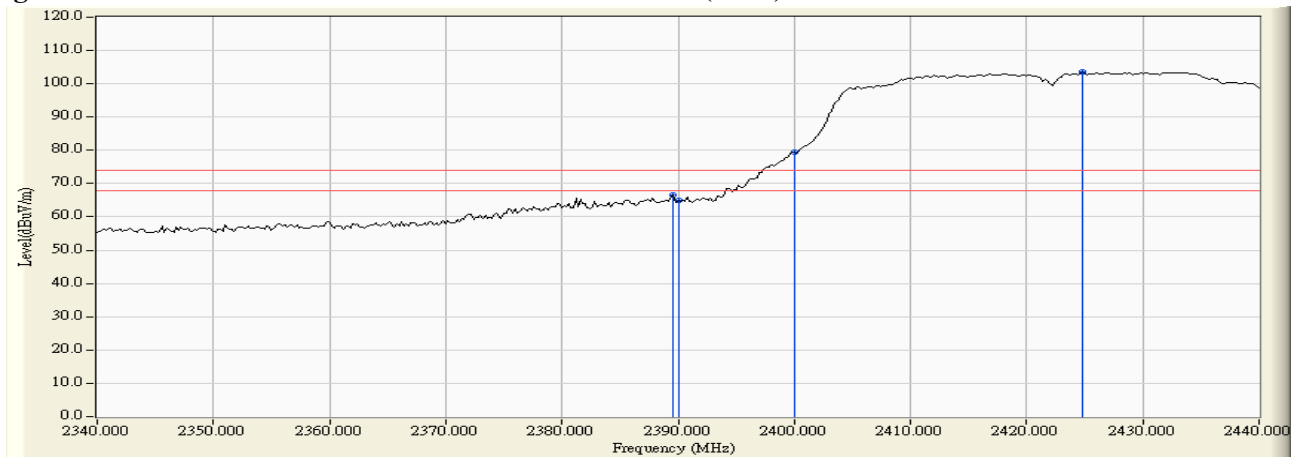

**Figure Channel 03: Vertical (Average)**

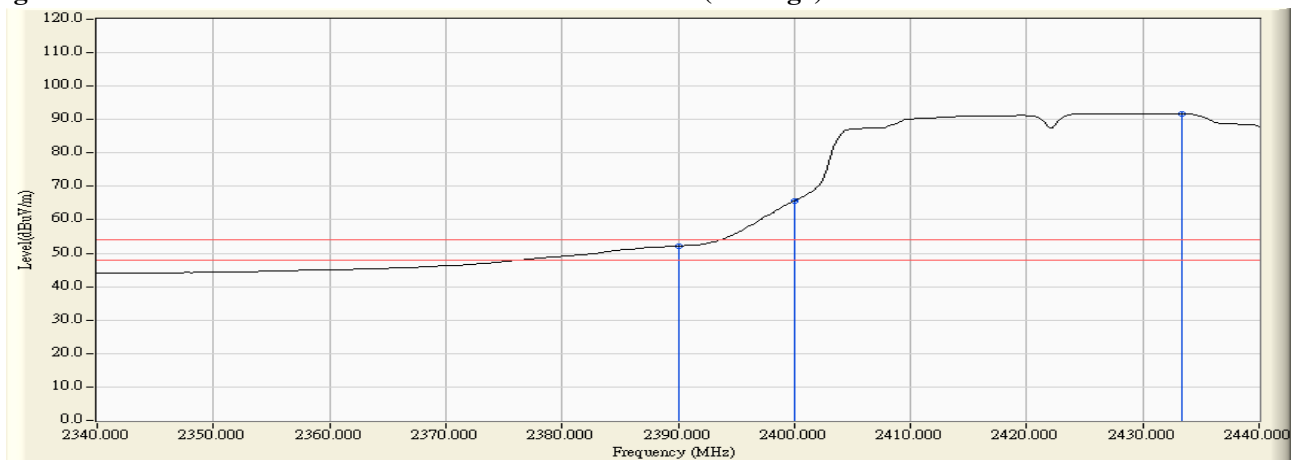



Note:

1. All readings above 1GHz are performed with peak and/or average measurements as necessary.
2. Peak measurements: RBW = 1MHz, VBW = 3 MHz, Sweep: Auto.
3. Average measurements: RBW = 1MHz, VBW = 10 Hz, Sweep: Auto.
4. “ \* ”, means this data is the worst emission level.
5. Measurement Level = Reading Level + Correct Factor.
6. The average measurement was not performed when the peak measured data under the limit of average detection.

Product : Intel® Dual Band Wireless-AC 8260  
 Test Item : Band Edge  
 Test Site : No.3 OATS  
 Test Mode : Mode 2 SISO B: Transmit - 802.11n-40BW\_15Mbps(2.4G Band)

**RF Radiated Measurement (Horizontal):**

Channel No.	Frequency (MHz)	Correct Factor (dB)	Reading Level (dBuV)	Emission Level (dBuV/m)	Peak Limit (dBuV/m)	Average Limit (dBuV/m)	Result
09 (Peak)	2455.700	31.972	74.534	106.506	--	--	Pass
09 (Peak)	2483.500	32.182	30.521	62.703	74.00	54.00	Pass
09 (Peak)	2484.700	32.192	32.521	64.712	74.00	54.00	Pass
09 (Average)	2456.900	31.982	62.476	94.457	--	--	Pass
09 (Average)	2483.000	32.179	18.921	51.099	74.00	54.00	Pass

**Figure Channel 09: Horizontal (Peak)**

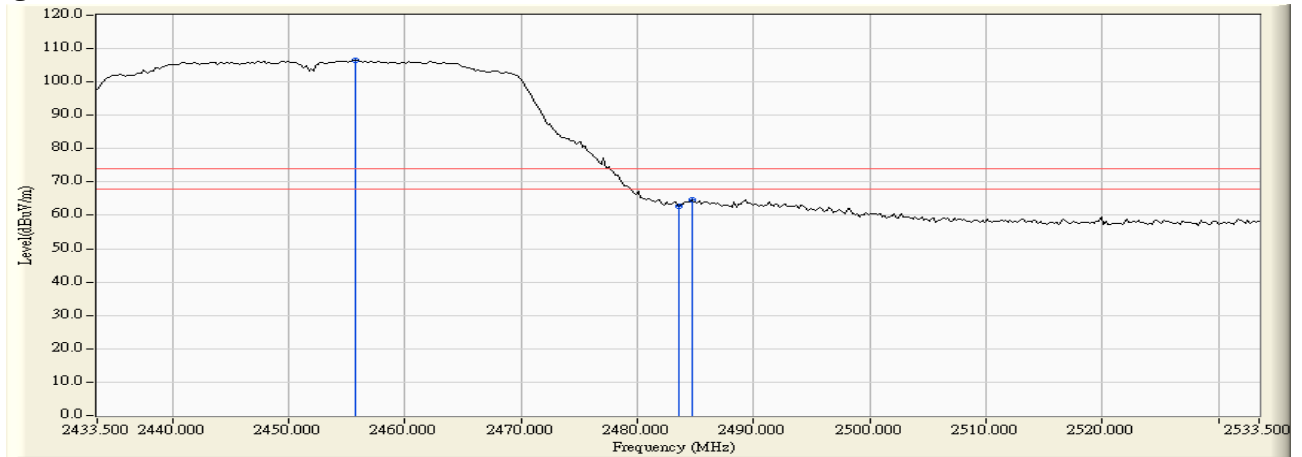

**Figure Channel 09: Horizontal (Average)**

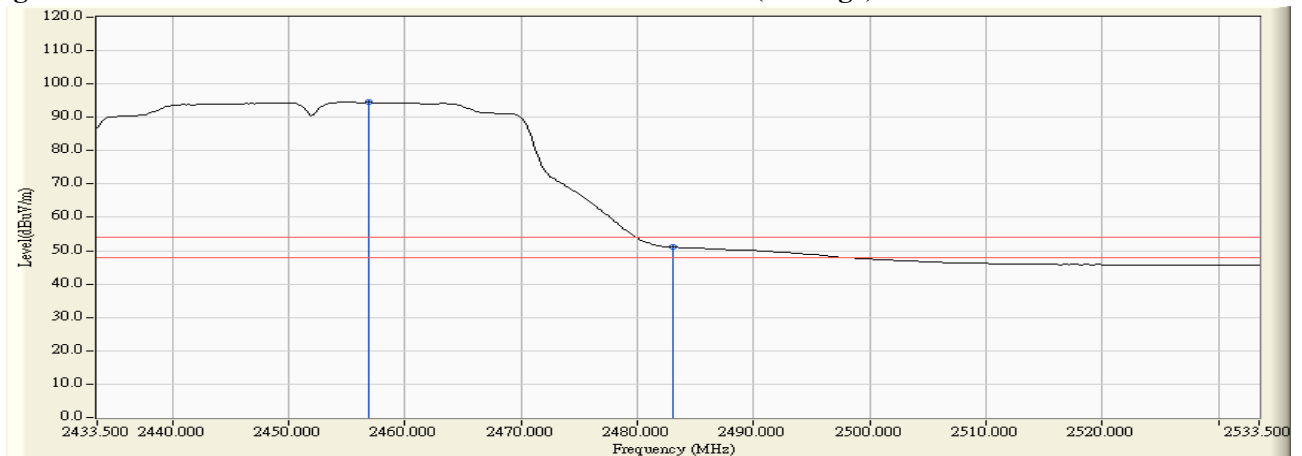

Note:

1. All readings above 1GHz are performed with peak and/or average measurements as necessary.
2. Peak measurements: RBW = 1MHz, VBW = 3 MHz, Sweep: Auto.
3. Average measurements: RBW = 1MHz, VBW = 10 Hz, Sweep: Auto.
4. “ \* ”, means this data is the worst emission level.
5. Measurement Level = Reading Level + Correct Factor.
6. The average measurement was not performed when the peak measured data under the limit of average detection.

Product : Intel® Dual Band Wireless-AC 8260  
 Test Item : Band Edge  
 Test Site : No.3 OATS  
 Test Mode : Mode 2 SISO B: Transmit - 802.11n-40BW\_15Mbps(2.4G Band)

**RF Radiated Measurement (Vertical):**

Channel No.	Frequency (MHz)	Correct Factor (dB)	Reading Level (dBuV)	Emission Level (dBuV/m)	Peak Limit (dBuV/m)	Average Limit (dBuV/m)	Result
09 (Peak)	2455.700	31.247	72.955	104.202	--	--	Pass
09 (Peak)	2483.500	31.435	30.632	62.067	74.00	54.00	Pass
09 (Peak)	2485.500	31.449	31.502	62.951	74.00	54.00	Pass
09 (Average)	2449.700	31.205	60.800	92.006	--	--	Pass
09 (Average)	2483.500	31.435	17.756	49.191	74.00	54.00	Pass

**Figure Channel 09: Vertical (Peak)**

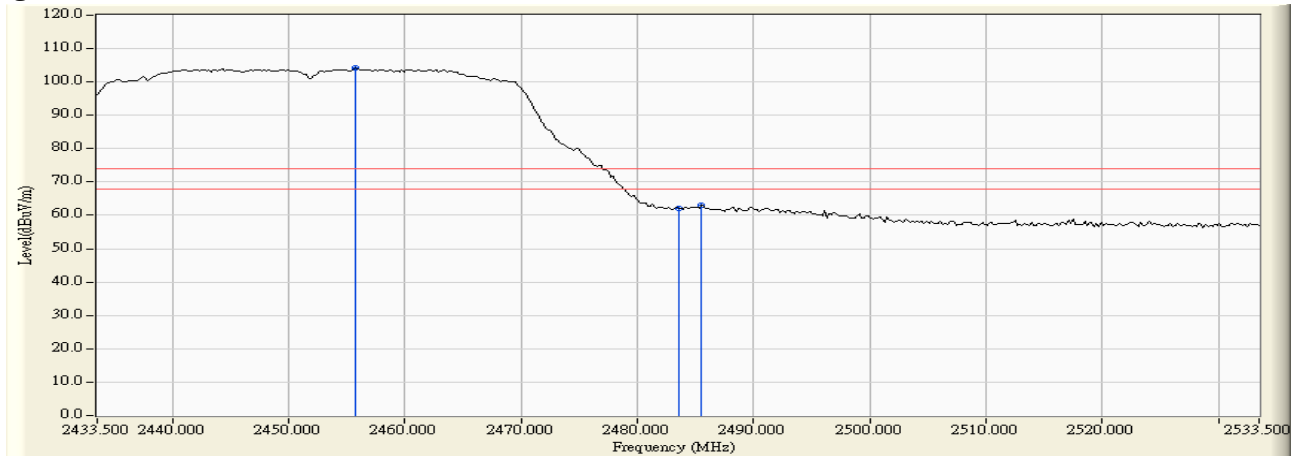

**Figure Channel 09: Vertical (Average)**

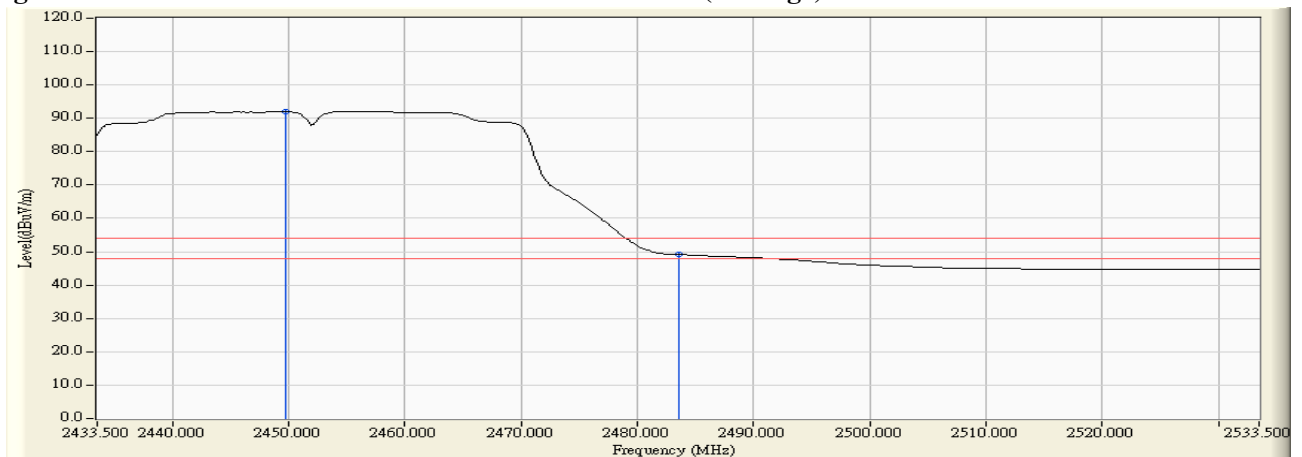

Note:

1. All readings above 1GHz are performed with peak and/or average measurements as necessary.
2. Peak measurements: RBW = 1MHz, VBW = 3 MHz, Sweep: Auto.
3. Average measurements: RBW = 1MHz, VBW = 10 Hz, Sweep: Auto.
4. “ \* ”, means this data is the worst emission level.
5. Measurement Level = Reading Level + Correct Factor.
6. The average measurement was not performed when the peak measured data under the limit of average detection.

Product : Intel® Dual Band Wireless-AC 8260  
 Test Item : Band Edge  
 Test Site : No.3 OATS  
 Test Mode : Mode 2 SISO B: Transmit - 802.11n-40BW\_15Mbps(2.4G Band)

**RF Radiated Measurement (Horizontal):**

Channel No.	Frequency (MHz)	Correct Factor (dB)	Reading Level (dBuV)	Emission Level (dBuV/m)	Peak Limit (dBuV/m)	Average Limit (dBuV/m)	Result
10 (Peak)	2459.100	31.998	70.570	102.567	--	--	Pass
10 (Peak)	2483.500	32.182	34.569	66.751	74.00	54.00	Pass
10 (Average)	2454.500	31.962	58.929	90.892	--	--	Pass
10 (Average)	2483.500	32.182	21.144	53.326	74.00	54.00	Pass

**Figure Channel 10: Horizontal (Peak)**

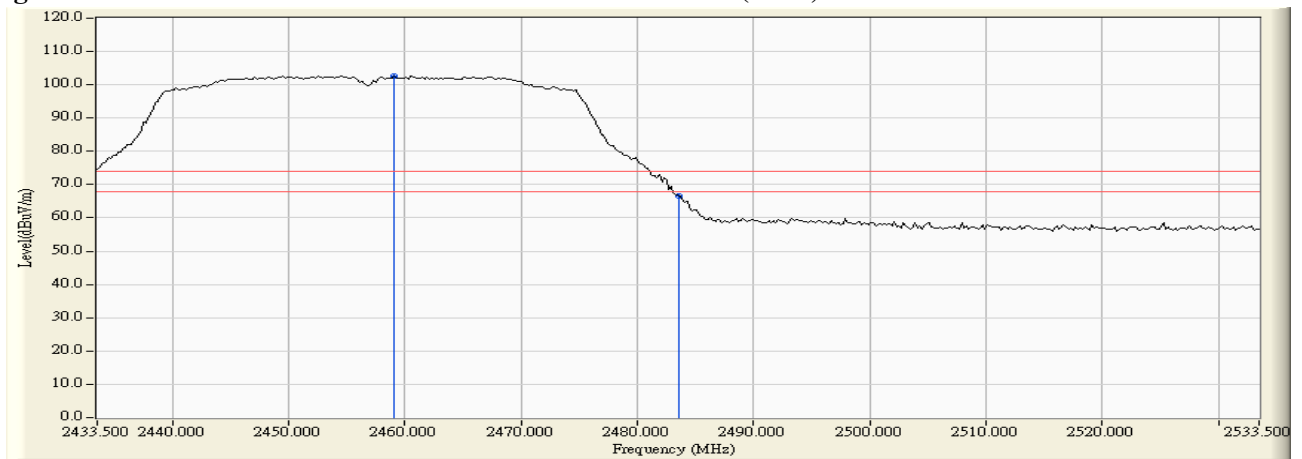

**Figure Channel 10: Horizontal (Average)**

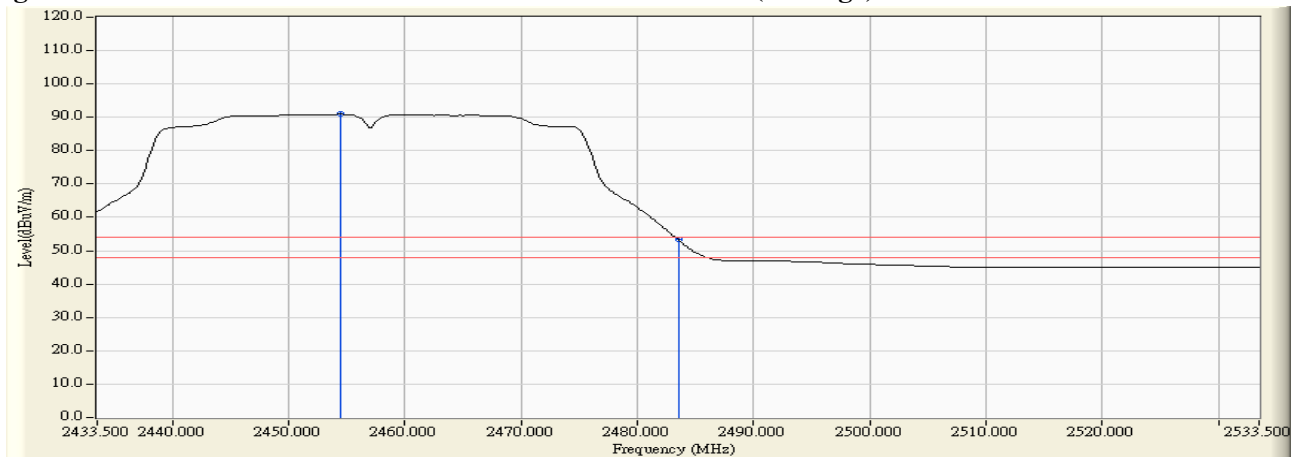

Note:

1. All readings above 1GHz are performed with peak and/or average measurements as necessary.
2. Peak measurements: RBW = 1MHz, VBW = 3 MHz, Sweep: Auto.
3. Average measurements: RBW = 1MHz, VBW = 10 Hz, Sweep: Auto.
4. “ \* ”, means this data is the worst emission level.
5. Measurement Level = Reading Level + Correct Factor.
6. The average measurement was not performed when the peak measured data under the limit of average detection.

Product : Intel® Dual Band Wireless-AC 8260  
 Test Item : Band Edge  
 Test Site : No.3 OATS  
 Test Mode : Mode 2 SISO B: Transmit - 802.11n-40BW\_15Mbps(2.4G Band)

**RF Radiated Measurement (Vertical):**

Channel No.	Frequency (MHz)	Correct Factor (dB)	Reading Level (dBuV)	Emission Level (dBuV/m)	Peak Limit (dBuV/m)	Average Limit (dBuV/m)	Result
10 (Peak)	2453.100	31.229	70.697	101.926	--	--	Pass
10 (Peak)	2483.500	31.435	33.092	64.527	74.00	54.00	Pass
10 (Average)	2454.500	31.238	57.070	88.309	--	--	Pass
10 (Average)	2483.500	31.435	19.795	51.230	74.00	54.00	Pass

**Figure Channel 10: Vertical (Peak)**

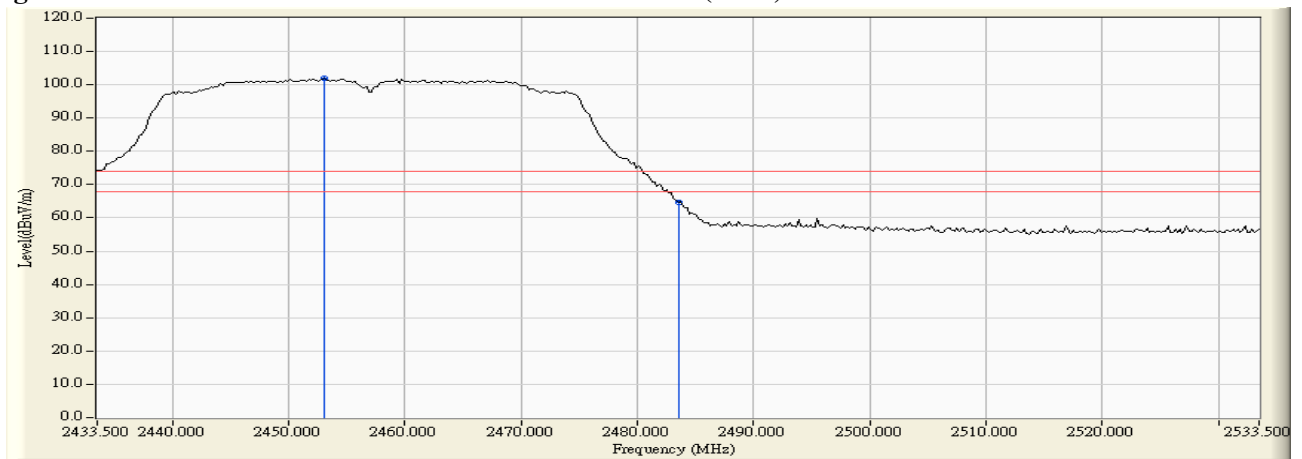

**Figure Channel 10: Vertical (Average)**

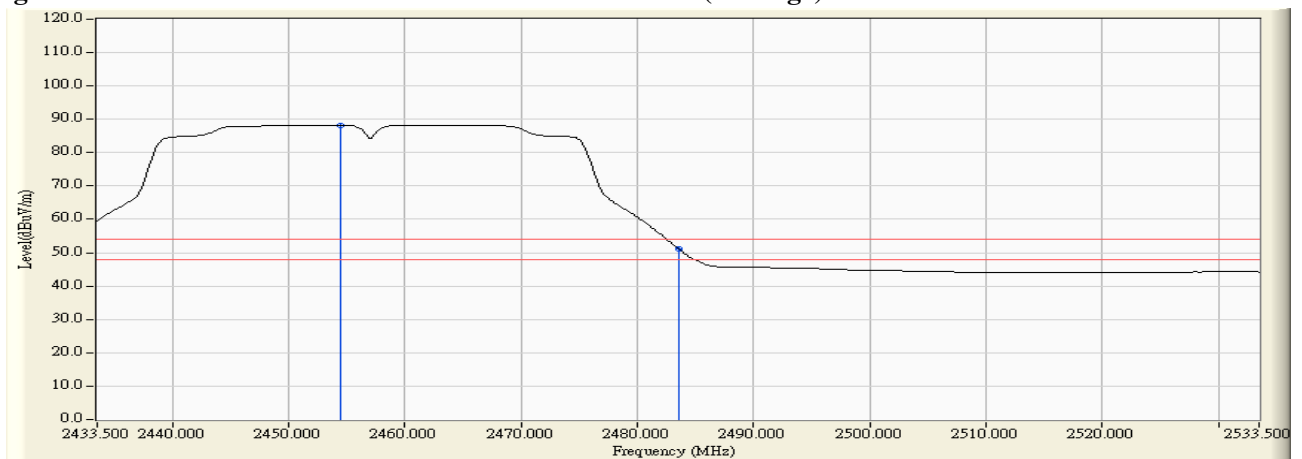



Note:

1. All readings above 1GHz are performed with peak and/or average measurements as necessary.
2. Peak measurements: RBW = 1MHz, VBW = 3 MHz, Sweep: Auto.
3. Average measurements: RBW = 1MHz, VBW = 10 Hz, Sweep: Auto.
4. “ \* ”, means this data is the worst emission level.
5. Measurement Level = Reading Level + Correct Factor.
6. The average measurement was not performed when the peak measured data under the limit of average detection.

Product : Intel® Dual Band Wireless-AC 8260  
 Test Item : Band Edge  
 Test Site : No.3 OATS  
 Test Mode : Mode 2 SISO B: Transmit - 802.11a 6Mbps

Test Frequency (MHz)	Measurement Level $\Delta$ (dB)	Limit $\Delta$ (dB)	Result
5745	43.21	>20	PASS

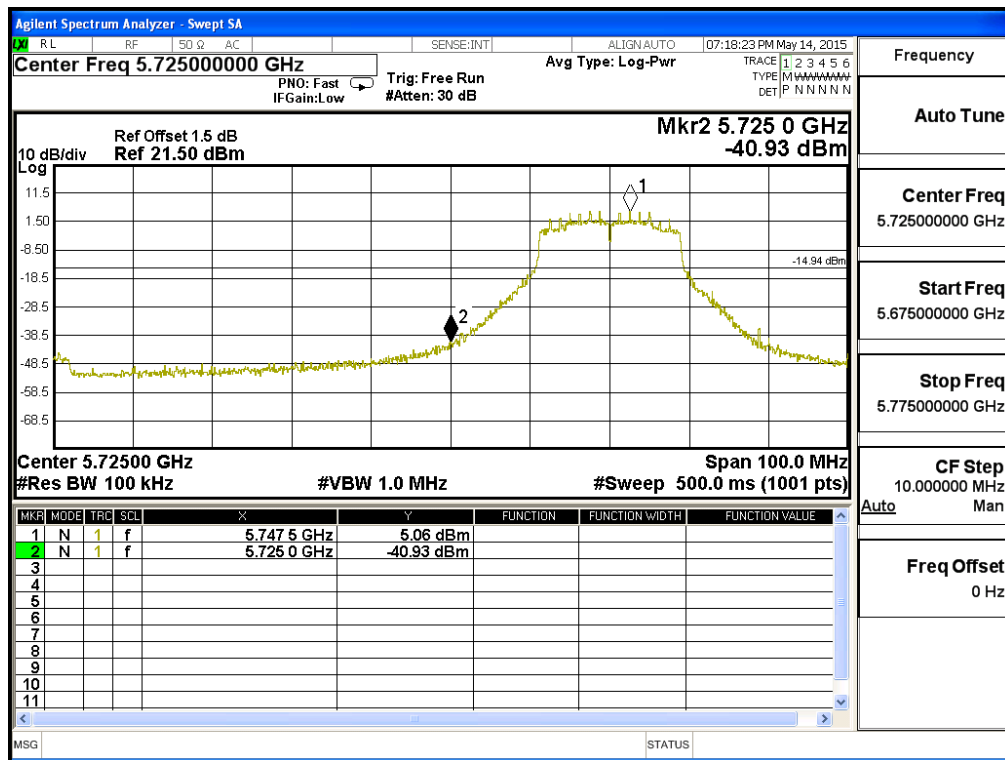

Product : Intel® Dual Band Wireless-AC 8260  
 Test Item : Band Edge  
 Test Site : No.3 OATS  
 Test Mode : Mode 2 SISO B: Transmit - 802.11a 6Mbps

Test Frequency (MHz)	Measurement Level $\Delta$ (dB)	Limit $\Delta$ (dB)	Result
5825	48.03	>20	PASS

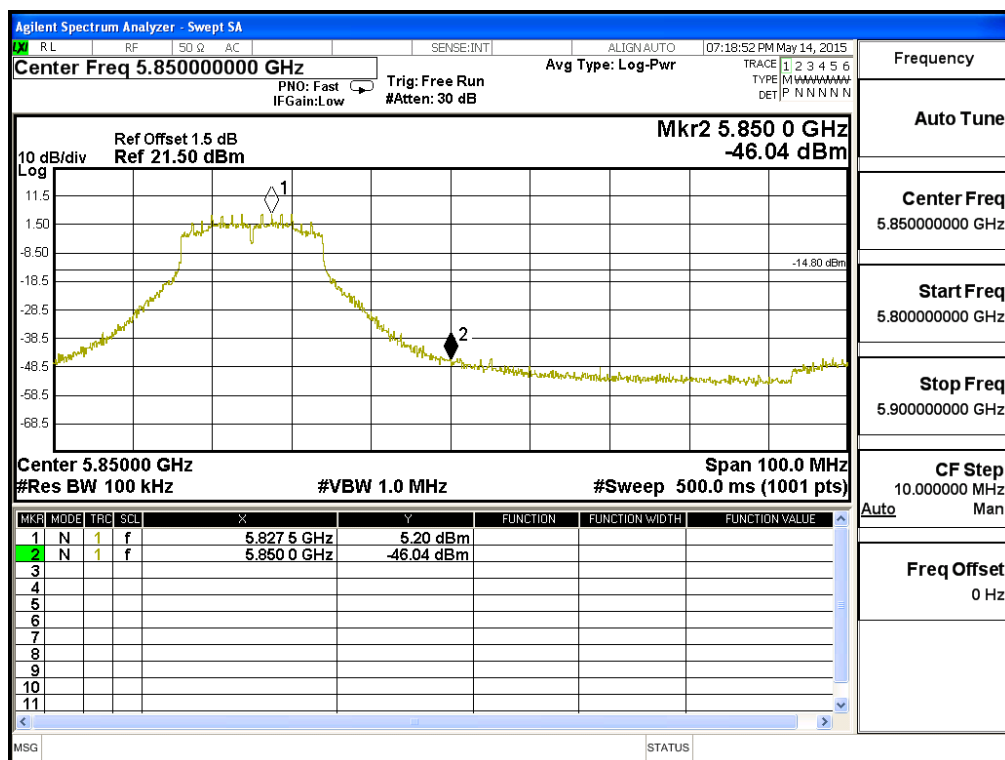

Product : Intel® Dual Band Wireless-AC 8260  
 Test Item : Band Edge  
 Test Site : No.3 OATS  
 Test Mode : Mode 2 SISO B: Transmit - 802.11n-20BW\_7.2Mbps(5G Band)

Test Frequency (MHz)	Measurement Level $\Delta$ (dB)	Limit $\Delta$ (dB)	Result
5745	43.21	>20	PASS

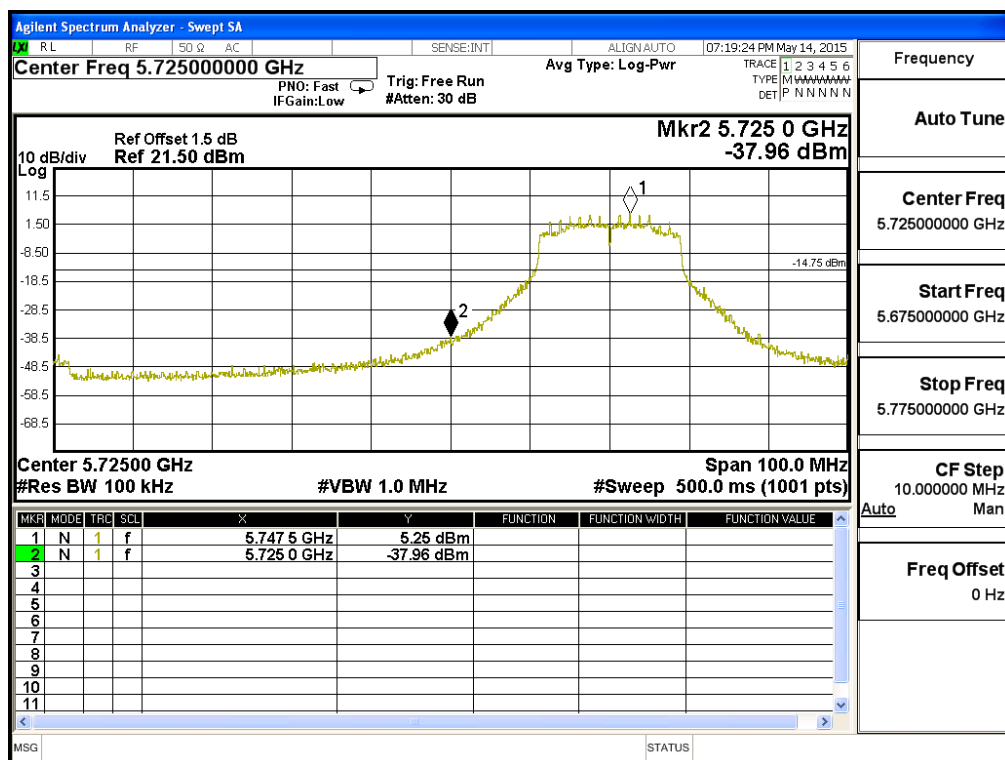

Product : Intel® Dual Band Wireless-AC 8260  
 Test Item : Band Edge  
 Test Site : No.3 OATS  
 Test Mode : Mode 2 SISO B: Transmit - 802.11n-20BW\_7.2Mbps(5G Band)

Test Frequency (MHz)	Measurement Level $\Delta$ (dB)	Limit $\Delta$ (dB)	Result
5825	48.03	>20	PASS

