

EMC Test Report

Application for Grant of Equipment Authorization

FCC Part 15 Subpart C

Models: 7265D2W and 7265D2W AN

FCC ID: PD97265D2

APPLICANT: Intel Mobile Communications
100 Center Point Circle, Suite 200
Columbia, SC 29210, USA

TEST SITE(S): National Technical Systems - Silicon Valley
41039 Boyce Road.
Fremont, CA. 94538-2435

IC SITE REGISTRATION #: 2845B-3; 2845B-4, 2845B-5, 2845B-7

REPORT DATE: July 8, 2014

FINAL TEST DATES: June 5 through June 20, 2014

TOTAL NUMBER OF PAGES: 210

PROGRAM MGR /
TECHNICAL REVIEWER:

QUALITY ASSURANCE DELEGATE /
FINAL REPORT PREPARER:



David W. Bare
Chief Engineer

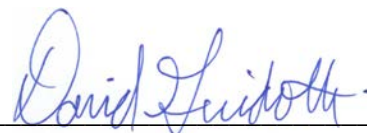

David Guidotti
Senior Technical Writer



National Technical Systems - Silicon Valley is accredited by the A2LA, certificate number 0214.26, to perform the test(s) listed in this report, except where noted otherwise. This report and the information contained herein represent the results of testing test articles identified and selected by the client performed to specifications and/or procedures selected by the client. National Technical Systems (NTS) makes no representations, expressed or implied, that such testing is adequate (or inadequate) to demonstrate efficiency, performance, reliability, or any other characteristic of the articles being tested, or similar products. This report should not be relied upon as an endorsement or certification by NTS of the equipment tested, nor does it represent any statement whatsoever as to its merchantability or fitness of the test article, or similar products, for a particular purpose. This report shall not be reproduced except in full

REVISION HISTORY

Rev#	Date	Comments	Modified By
-	July 8, 2014	First release	

TABLE OF CONTENTS

REVISION HISTORY2

TABLE OF CONTENTS3

SCOPE.....4

OBJECTIVE4

STATEMENT OF COMPLIANCE.....5

DEVIATIONS FROM THE STANDARDS.....5

TEST RESULTS SUMMARY6

 DIGITAL TRANSMISSION SYSTEMS (2400 – 2483.5MHZ)6

 GENERAL REQUIREMENTS APPLICABLE TO ALL BANDS6

 MEASUREMENT UNCERTAINTIES7

EQUIPMENT UNDER TEST (EUT) DETAILS.....8

 GENERAL.....8

 ANTENNA SYSTEM8

 ENCLOSURE.....8

 MODIFICATIONS8

 SUPPORT EQUIPMENT8

 EUT INTERFACE PORTS9

 EUT OPERATION9

TEST SITE.....10

 GENERAL INFORMATION10

 CONDUCTED EMISSIONS CONSIDERATIONS10

 RADIATED EMISSIONS CONSIDERATIONS10

MEASUREMENT INSTRUMENTATION11

 RECEIVER SYSTEM11

 INSTRUMENT CONTROL COMPUTER11

 LINE IMPEDANCE STABILIZATION NETWORK (LISN)11

 FILTERS/ATTENUATORS12

 ANTENNAS.....12

 ANTENNA MAST AND EQUIPMENT TURNTABLE12

 INSTRUMENT CALIBRATION.....12

TEST PROCEDURES13

 EUT AND CABLE PLACEMENT13

 CONDUCTED EMISSIONS.....13

 RADIATED EMISSIONS14

 CONDUCTED EMISSIONS FROM ANTENNA PORT16

 BANDWIDTH MEASUREMENTS16

 SPECIFICATION LIMITS AND SAMPLE CALCULATIONS17

 CONDUCTED EMISSIONS SPECIFICATION LIMITS: FCC 15.207; FCC 15.107(A), RSS GEN17

 GENERAL TRANSMITTER RADIATED EMISSIONS SPECIFICATION LIMITS18

 RECEIVER RADIATED SPURIOUS EMISSIONS SPECIFICATION LIMITS18

 OUTPUT POWER LIMITS – DIGITAL TRANSMISSION SYSTEMS18

 TRANSMIT MODE SPURIOUS RADIATED EMISSIONS LIMITS – FHSS AND DTS SYSTEMS.....19

 SAMPLE CALCULATIONS - CONDUCTED EMISSIONS19

 SAMPLE CALCULATIONS - RADIATED EMISSIONS19

 SAMPLE CALCULATIONS - FIELD STRENGTH TO EIRP CONVERSION.....20

APPENDIX A TEST EQUIPMENT CALIBRATION DATA21

APPENDIX B TEST DATA24

END OF REPORT210

SCOPE

An electromagnetic emissions test has been performed on the Intel Mobile Communications model 7265D2W, pursuant to the following rules:

FCC Part 15 Subpart C

Conducted and radiated emissions data has been collected, reduced, and analyzed within this report in accordance with measurement guidelines set forth in the following reference standards and as outlined in National Technical Systems - Silicon Valley test procedures:

ANSI C63.10-2009

FCC DTS Measurement Guidance KDB558074

The intentional radiator above has been tested in a simulated typical installation to demonstrate compliance with the relevant Industry Canada performance and procedural standards.

Final system data was gathered in a mode that tended to maximize emissions by varying orientation of EUT, orientation of power and I/O cabling, antenna search height, and antenna polarization.

Every practical effort was made to perform an impartial test using appropriate test equipment of known calibration. All pertinent factors have been applied to reach the determination of compliance.

OBJECTIVE

The primary objective of the manufacturer is compliance with the regulations outlined in the previous section.

Prior to marketing in the USA, all unlicensed transmitters and transceivers require certification. Receive-only devices operating between 30 MHz and 960 MHz are subject to either certification or a manufacturer's declaration of conformity, with all other receive-only devices exempt from the technical requirements.

Prior to marketing in Canada, Class I transmitters, receivers and transceivers require certification. Class II devices are required to meet the appropriate technical requirements but are exempt from certification requirements.

Certification is a procedure where the manufacturer submits test data and technical information to a certification body and receives a certificate or grant of equipment authorization upon successful completion of the certification body's review of the submitted documents. Once the equipment authorization has been obtained, the label indicating compliance must be attached to all identical units, which are subsequently manufactured.

Testing was performed only on model 7265D2W. This model was considered representative of the following models:

7265D2W and 7265D2W AN

STATEMENT OF COMPLIANCE

The tested sample of Intel Mobile Communications model 7265D2W complied with the requirements of the following regulations:

Industry Canada RSS-Gen Issue 3

RSS 210 Issue 8 “Low-power Licence-exempt Radiocommunication Devices (All Frequency Bands): Category I Equipment”

FCC Part 15 Subpart C

Maintenance of compliance is the responsibility of the manufacturer. Any modifications to the product should be assessed to determine their potential impact on the compliance status of the device with respect to the standards detailed in this test report.

The test results recorded herein are based on a single type test of Intel Mobile Communications model 7265D2W and therefore apply only to the tested sample. The sample was selected and prepared by Steven Hackett of Intel Mobile Communications.

DEVIATIONS FROM THE STANDARDS

No deviations were made from the published requirements listed in the scope of this report.

TEST RESULTS SUMMARY**DIGITAL TRANSMISSION SYSTEMS (2400 – 2483.5MHz)**

FCC Rule Part	RSS Rule Part	Description	Measured Value / Comments	Limit / Requirement	Result
15.247(a)	RSS 210 A8.2	Digital Modulation	Systems uses OFDM / DSSS techniques	System must utilize a digital transmission technology	Complies
15.247 (a) (2)	RSS 210 A8.2 (1)	6dB Bandwidth	10.04 MHz	>500kHz	Complies
15.247 (b) (3)	RSS 210 A8.2 (4)	Output Power (multipoint systems)	b mode: 18.3 dBm g mode: 20.4 dBm n20 mode: 22.8 dBm n40 mode: 21.8 dBm BLE mode: 3.5 dBm EIRP = 0.400 W ^{Note 1}	1Watt, EIRP limited to 4 Watts.	Complies
15.247(d)	RSS 210 A8.2 (2)	Power Spectral Density	1.3 dBm / 3kHz	8dBm/3kHz	Complies
15.247(c)	RSS 210 A8.5	Antenna Port Spurious Emissions 30MHz – 25 GHz	All spurious emissions < -20dBc	< -20dBc ^{Note 2}	Complies
15.247(c) / 15.209	RSS 210 A8.5	Radiated Spurious Emissions 30MHz – 25 GHz	53.5 dBμV/m @ 2390.0 MHz (-0.5 dB)	15.207 in restricted bands, all others < -20dBc	Complies
Note 1: EIRP calculated using antenna gain of 3.2 dBi for the highest EIRP system.					

GENERAL REQUIREMENTS APPLICABLE TO ALL BANDS

FCC Rule Part	RSS Rule part	Description	Measured Value / Comments	Limit / Requirement	Result (margin)
15.203	-	RF Connector	Unique iPex-4 connector	Unique or integral antenna required	Complies
15.207	RSS GEN Table 4	AC Conducted Emissions	62.0 dBμV @ 0.152 MHz (-3.9 dB)	Refer to page 17	Complies
15.247 (b) (5) / 15.407 (f)	RSS 102	RF Exposure Requirements	Refer to SAR report and RSS 102 declaration and User Manual statements	Refer to OET 65, FCC Part 1 and RSS 102	Complies

MEASUREMENT UNCERTAINTIES

ISO/IEC 17025 requires that an estimate of the measurement uncertainties associated with the emissions test results be included in the report. The measurement uncertainties given below are based on a 95% confidence level and were calculated in accordance with UKAS document LAB 34.

Measurement Type	Measurement Unit	Frequency Range	Expanded Uncertainty
RF power, conducted (power meter)	dBm	25 to 7000 MHz	± 0.52 dB
RF power, conducted (Spectrum analyzer)	dBm	25 to 7000 MHz	± 0.7 dB
Conducted emission of transmitter	dBm	25 to 26500 MHz	± 0.7 dB
Conducted emission of receiver	dBm	25 to 26500 MHz	± 0.7 dB
Radiated emission (substitution method)	dBm	25 to 26500 MHz	± 2.5 dB
Radiated emission (field strength)	dB μ V/m	25 to 1000 MHz	± 3.6 dB
		1000 to 40000 MHz	± 6.0 dB
Conducted Emissions (AC Power)	dB μ V	0.15 to 30 MHz	± 2.4 dB

EQUIPMENT UNDER TEST (EUT) DETAILS**GENERAL**

The Intel Mobile Communications models 7265D2W and 7265D2W AN are 2x2 Wi-Fi and Bluetooth radio modules which support 802.11abgnac in 2x2 (MIMO) and 1x1 (SISO) modes & BT 4.0 (Basic rate, EDR and BLE modes). Since the EUT would be placed on a tabletop during operation, the EUT was treated as tabletop equipment during testing to simulate the end-user environment. The electrical rating of the EUT is 3.3 VDC.

The sample was received on June 5, 2014 and tested on June 5 through June 20, 2014. The EUT consisted of the following component(s):

Manufacturer	Model	Description	Serial Number	FCC and Canada IDs
Intel Mobile Communications	7265D2W	M.2 Card form factor Bluetooth / IEEE 802.11a/b/g/n/ac wireless network adapter	00:15:00:F1:5B:5D or 00:15:00:F1:5B:3A	PD97265D2 1000M-7265D2

ANTENNA SYSTEM

The EUT antenna is a two-antenna PIFA antenna system – Shanghai Universe Communication Electron Co., Ltd. One or both antennas are used for WiFi operation and one for Bluetooth operation. For Bluetooth: Tx is chain B, Rx is chain B. For WiFi, only Chain A is used for transmit in the 2.4GHz band when Bluetooth is active, both chains can be used in 5GHz bands.

ENCLOSURE

The EUT has no enclosure. It is designed to be installed within the enclosure of a host computer.

MODIFICATIONS

No modifications were made to the EUT during the time the product was at NTS Silicon Valley.

SUPPORT EQUIPMENT

The following equipment was used as support equipment for testing:

Company	Model	Description	Serial Number	FCC ID
Dell	DCCY	Desktop computer	BJYN64J	-
Hanns G	HX191DPBUFLF6	LCD monitor	017GR3XY00286	-
Logitech	5680157	Mouse	LNA20956449	-
Intel	NGFF Extension REV 01	Extension Board	4164912-200	-

EUT INTERFACE PORTS

The I/O cabling configuration during testing was as follows:

Port	Connected To	Description	Cable(s)	
			Shielded or Unshielded	Length(m)
Antenna (x2)	Antenna	RF cable	Shielded	0.3
Desktop Mini PCIe Slot	Extension Board	Ribbon	Unshielded	0.8
Desktop USB	Extension Board	Multiwire	Unshielded	1.2
Desktop AC power supply	AC Main	power cable	Unshielded	2.3
Power (test fixture)	Computer	Multiwire	Unshielded	1.5
Desktop USB	Keyboard	Multiwire	Shielded	1.0
Desktop USB	Mouse	Multiwire	Shielded	1.0
Desktop Display	Monitor	Multiwire	Shielded	1.0

EUT OPERATION

During emissions testing the EUT was transmitting on the frequency & at the power level selected in the proprietary DRTU control software.

TEST SITE**GENERAL INFORMATION**

Final test measurements were taken at the test sites listed below. Pursuant to section 2.948 of the FCC's Rules and section 3.3 of RSP-100, construction, calibration, and equipment data has been filed with the Commission and with industry Canada.

Site	Designation / Registration Numbers		Location
	FCC	Canada	
Chamber 3	US0027	2845B-3	41039 Boyce Road Fremont, CA 94538-2435
Chamber 4	US0027	2845B-4	
Chamber 5	US0027	2845B-5	
Chamber 7	US0027	2845B-7	

ANSI C63.4 recommends that ambient noise at the test site be at least 6 dB below the allowable limits. Ambient levels are below this requirement. The test site(s) contain separate areas for radiated and conducted emissions testing. Considerable engineering effort has been expended to ensure that the facilities conform to all pertinent requirements of ANSI C63.4.

CONDUCTED EMISSIONS CONSIDERATIONS

Conducted emissions testing is performed in conformance with ANSI C63.10. Measurements are made with the EUT connected to the public power network through a nominal, standardized RF impedance, which is provided by a line impedance stabilization network, known as a LISN. A LISN is inserted in series with each current-carrying conductor in the EUT power cord.

RADIATED EMISSIONS CONSIDERATIONS

The FCC has determined that radiation measurements made in a shielded enclosure are not suitable for determining levels of radiated emissions. Radiated measurements are performed in an open field environment or in a semi-anechoic chamber. The test sites are maintained free of conductive objects within the CISPR defined elliptical area incorporated in ANSI C63.4 guidelines and meet the Normalized Site Attenuation (NSA) requirements of ANSI C63.4.

MEASUREMENT INSTRUMENTATION

RECEIVER SYSTEM

An EMI receiver as specified in CISPR 16-1-1 is used for emissions measurements. The receivers used can measure over the frequency range of 9 kHz up to 2000 MHz. These receivers allow both ease of measurement and high accuracy to be achieved. The receivers have Peak, Average, and CISPR (Quasi-peak) detectors built into their design so no external adapters are necessary. The receiver automatically sets the required bandwidth for the CISPR detector used during measurements. If the repetition frequency of the signal being measured is below 20Hz, peak measurements are made in lieu of Quasi-Peak measurements.

For measurements above the frequency range of the receivers, a spectrum analyzer is utilized because it provides visibility of the entire spectrum along with the precision and versatility required to support engineering analysis. Average measurements above 1000MHz are performed on the spectrum analyzer using the linear-average method with a resolution bandwidth of 1 MHz and a video bandwidth of 10 Hz, unless the signal is pulsed in which case the average (or video) bandwidth of the measuring instrument is reduced to onset of pulse desensitization and then increased.

INSTRUMENT CONTROL COMPUTER

The receivers utilize either a Rohde & Schwarz EZM Spectrum Monitor/Controller or contain an internal Spectrum Monitor/Controller to view and convert the receiver measurements to the field strength at an antenna or voltage developed at the LISN measurement port, which is then compared directly with the appropriate specification limit. This provides faster, more accurate readings by performing the conversions described under Sample Calculations within the Test Procedures section of this report. Results are printed in a graphic and/or tabular format, as appropriate. A personal computer is used to record all measurements made with the receivers.

The Spectrum Monitor provides a visual display of the signal being measured. In addition, the controller or a personal computer run automated data collection programs which control the receivers. This provides added accuracy since all site correction factors, such as cable loss and antenna factors are added automatically.

LINE IMPEDANCE STABILIZATION NETWORK (LISN)

Line conducted measurements utilize a fifty microhenry Line Impedance Stabilization Network as the monitoring point. The LISN used also contains a 250 uH CISPR adapter. This network provides for calibrated radio frequency noise measurements by the design of the internal low pass and high pass filters on the EUT and measurement ports, respectively.

FILTERS/ATTENUATORS

External filters and precision attenuators are often connected between the receiving antenna or LISN and the receiver. This eliminates saturation effects and non-linear operation due to high amplitude transient events.

ANTENNAS

A loop antenna is used below 30 MHz. For the measurement range 30 MHz to 1000 MHz either a combination of a biconical antenna and a log periodic or a bi-log antenna is used. Above 1000 MHz, horn antennas are used. The antenna calibration factors to convert the received voltage to an electric field strength are included with appropriate cable loss and amplifier gain factors to determine an overall site factor, which is then programmed into the test receivers or incorporated into the test software.

ANTENNA MAST AND EQUIPMENT TURNTABLE

The antennas used to measure the radiated electric field strength are mounted on a non-conductive antenna mast equipped with a motor-drive to vary the antenna height. Measurements below 30 MHz are made with the loop antenna at a fixed height of 1m above the ground plane.

ANSI C63.10 specifies that the test height above ground for table mounted devices shall be 80 centimeters. Floor mounted equipment shall be placed on the ground plane if the device is normally used on a conductive floor or separated from the ground plane by insulating material from 3 to 12 mm if the device is normally used on a non-conductive floor as specified in ANSI C63.4. During radiated measurements, the EUT is positioned on a motorized turntable in conformance with this requirement.

INSTRUMENT CALIBRATION

All test equipment is regularly checked to ensure that performance is maintained in accordance with the manufacturer's specifications. All antennas are calibrated at regular intervals with respect to tuned half-wave dipoles. An exhibit of this report contains the list of test equipment used and calibration information.

TEST PROCEDURES

EUT AND CABLE PLACEMENT

The regulations require that interconnecting cables be connected to the available ports of the unit and that the placement of the unit and the attached cables simulate the worst case orientation that can be expected from a typical installation, so far as practicable. To this end, the position of the unit and associated cabling is varied within the guidelines of ANSI C63.10, and the worst-case orientation is used for final measurements.

CONDUCTED EMISSIONS

Conducted emissions are measured at the plug end of the power cord supplied with the EUT. Excess power cord length is wrapped in a bundle between 30 and 40 centimeters in length near the center of the cord. Preliminary measurements are made to determine the highest amplitude emission relative to the specification limit for all the modes of operation. Placement of system components and varying of cable positions are performed in each mode. A final peak mode scan is then performed in the position and mode for which the highest emission was noted on all current carrying conductors of the power cord.

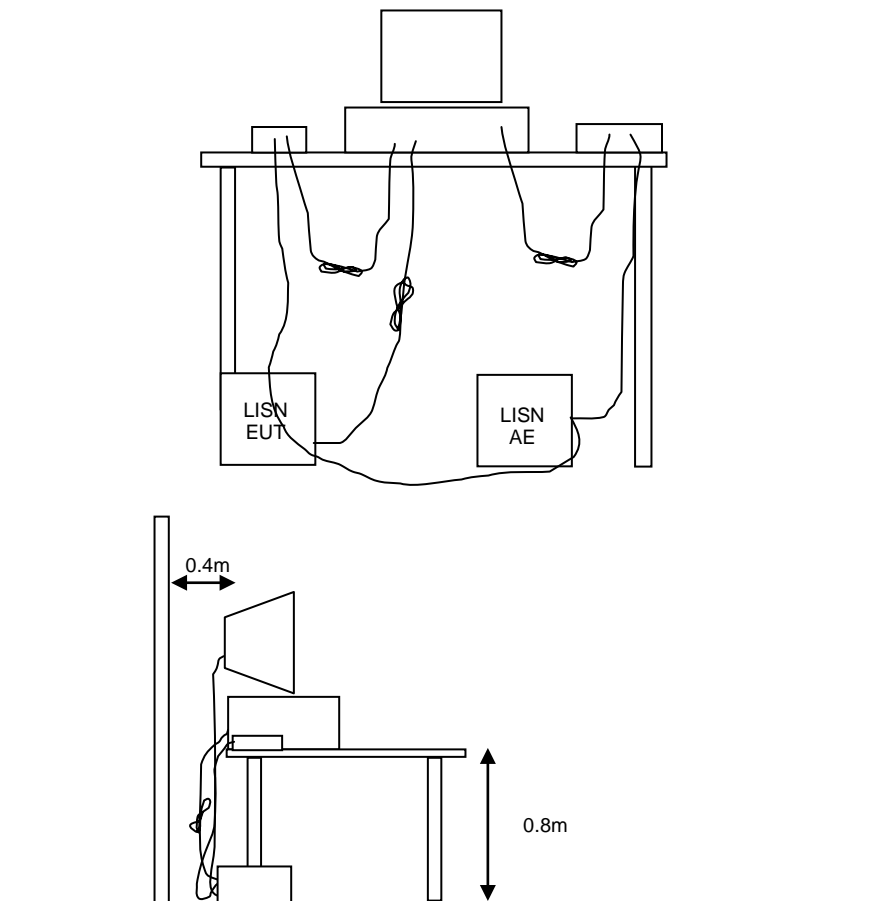

Figure 1 Typical Conducted Emissions Test Configuration

RADIATED EMISSIONS

A preliminary scan of the radiated emissions is performed in which all significant EUT frequencies are identified with the system in a nominal configuration. At least two scans are performed, one scan for each antenna polarization (horizontal and vertical; loop parallel and perpendicular to the EUT). During the preliminary scans, the EUT is rotated through 360°, the antenna height is varied (for measurements above 30 MHz) and cable positions are varied to determine the highest emission relative to the limit. Preliminary scans may be performed in a fully anechoic chamber for the purposes of identifying the frequencies of the highest emissions from the EUT.

A speaker is provided in the receiver to aid in discriminating between EUT and ambient emissions. Other methods used during the preliminary scan for EUT emissions involve scanning with near field magnetic loops, monitoring I/O cables with RF current clamps, and cycling power to the EUT.

Final maximization is a phase in which the highest amplitude emissions identified in the spectral search are viewed while the EUT azimuth angle is varied from 0 to 360 degrees relative to the receiving antenna. The azimuth, which results in the highest emission is then maintained while varying the antenna height from one to four meters (for measurements above 30 MHz, measurements below 30 MHz are made with the loop antenna at a fixed height of 1m). The result is the identification of the highest amplitude for each of the highest peaks. Each recorded level is corrected in the receiver using appropriate factors for cables, connectors, antennas, and preamplifier gain.

When testing above 18 GHz, the receive antenna is located at 1meter from the EUT and the antenna height is restricted to a maximum of 2.5 meters.

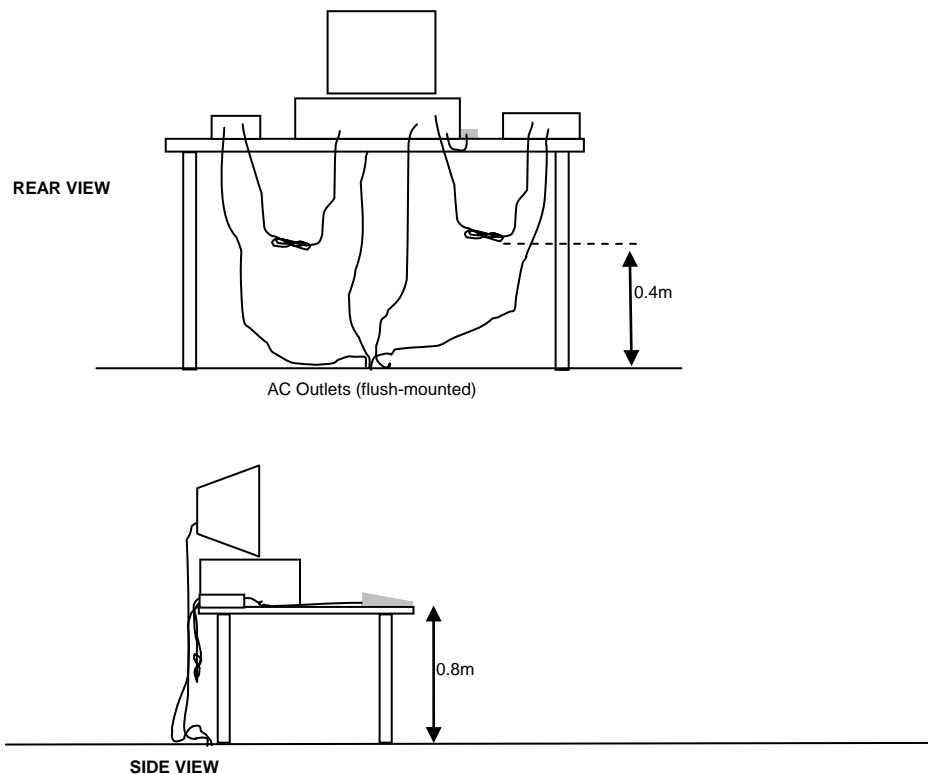

Typical Test Configuration for Radiated Field Strength Measurements

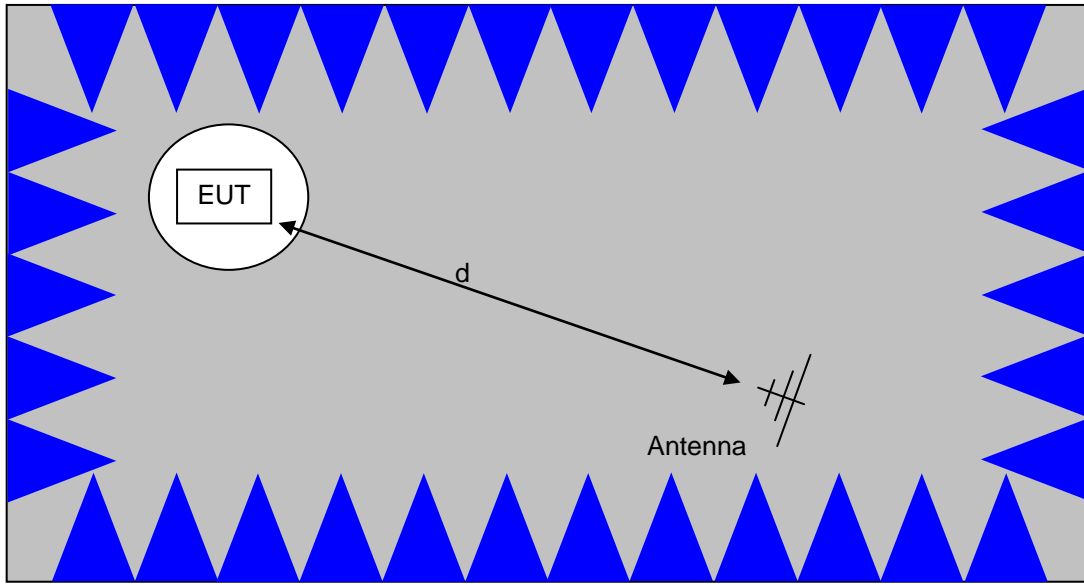

The anechoic materials on the walls and ceiling ensure compliance with the normalized site attenuation requirements of CISPR 16 / CISPR 22 / ANSI C63.4 for an alternate test site at the measurement distances used.

Floor-standing equipment is placed on the floor with insulating supports between the unit and the ground plane.

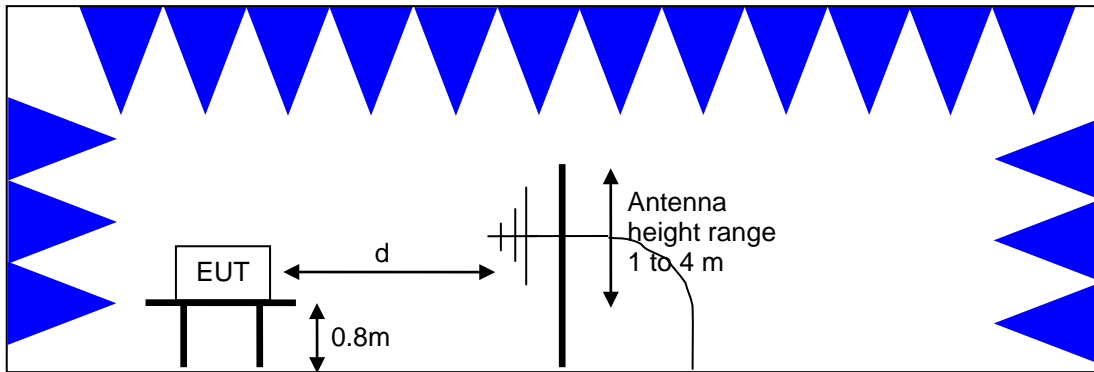

Test Configuration for Radiated Field Strength Measurements
Semi-Anechoic Chamber, Plan and Side Views

CONDUCTED EMISSIONS FROM ANTENNA PORT

Direct measurements of power, bandwidth and power spectral density are performed, where possible, with the antenna port of the EUT connected to either the power meter or spectrum analyzer via a suitable attenuator and/or filter. These are used to ensure that the front end of the measurement instrument is not overloaded by the fundamental transmission.

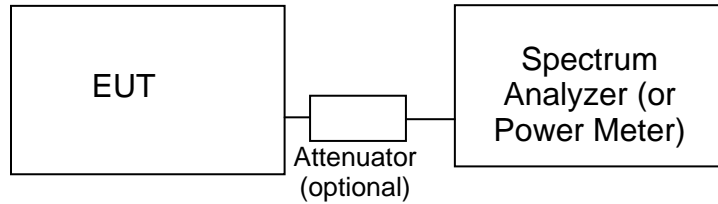
**Test Configuration for Antenna Port Measurements**

Measurement bandwidths (video and resolution) are set in accordance with the relevant standards and NTS Silicon Valley's test procedures for the type of radio being tested. When power measurements are made using a resolution bandwidth less than the signal bandwidth the power is calculated by summing the power across the signal bandwidth using either the analyzer channel power function or by capturing the trace data and calculating the power using software. In both cases the summed power is corrected to account for the equivalent noise bandwidth (ENBW) of the resolution bandwidth used.

If power averaging is used (typically for certain digital modulation techniques), the EUT is configured to transmit continuously. Power averaging is performed using either the built-in function of the analyzer or, if the analyzer does not feature power averaging, using external software. In both cases the average power is calculated over a number of sweeps (typically 100). When the EUT cannot be configured to continuously transmit then either the analyzer is configured to perform a gated sweep to ensure that the power is averaged over periods that the device is transmitting or power averaging is disabled and a max-hold feature is used.

If a power meter is used to make output power measurements the sensor head type (peak or average) is stated in the test data table.

BANDWIDTH MEASUREMENTS

The 6dB, 20dB, 26dB and/or 99% signal bandwidth are measured using the bandwidths recommended by ANSI C63.10 and RSS GEN.

SPECIFICATION LIMITS AND SAMPLE CALCULATIONS

The limits for conducted emissions are given in units of microvolts, and the limits for radiated emissions are given in units of microvolts per meter at a specified test distance. Data is measured in the logarithmic form of decibels relative to one microvolt, or dB microvolts (dBuV). For radiated emissions, the measured data is converted to the field strength at the antenna in dB microvolts per meter (dBuV/m). The results are then converted to the linear forms of uV and uV/m for comparison to published specifications.

For reference, converting the specification limits from linear to decibel form is accomplished by taking the base ten logarithm, then multiplying by 20. These limits in both linear and logarithmic form are as follows:

CONDUCTED EMISSIONS SPECIFICATION LIMITS: FCC 15.207; FCC 15.107(a), RSS GEN

The table below shows the limits for the emissions on the AC power line from an intentional radiator and a receiver.

Frequency (MHz)	Average Limit (dBuV)	Quasi Peak Limit (dBuV)
0.150 to 0.500	Linear decrease on logarithmic frequency axis between 56.0 and 46.0	Linear decrease on logarithmic frequency axis between 66.0 and 56.0
0.500 to 5.000	46.0	56.0
5.000 to 30.000	50.0	60.0

GENERAL TRANSMITTER RADIATED EMISSIONS SPECIFICATION LIMITS

The table below shows the limits for the spurious emissions from transmitters that fall in restricted bands¹ (with the exception of transmitters operating under FCC Part 15 Subpart D and RSS 210 Annex 9), the limits for all emissions from a low power device operating under the general rules of RSS 310 (tables 3 and 4), RSS 210 (table 2) and FCC Part 15 Subpart C section 15.209.

Frequency Range (MHz)	Limit (uV/m)	Limit (dBuV/m @ 3m)
0.009-0.490	2400/F _{KHZ} @ 300m	67.6-20*log ₁₀ (F _{KHZ}) @ 300m
0.490-1.705	24000/F _{KHZ} @ 30m	87.6-20*log ₁₀ (F _{KHZ}) @ 30m
1.705 to 30	30 @ 30m	29.5 @ 30m
30 to 88	100 @ 3m	40 @ 3m
88 to 216	150 @ 3m	43.5 @ 3m
216 to 960	200 @ 3m	46.0 @ 3m
Above 960	500 @ 3m	54.0 @ 3m

RECEIVER RADIATED SPURIOUS EMISSIONS SPECIFICATION LIMITS

The table below shows the limits for the spurious emissions from receivers as detailed in FCC Part 15.109, RSS 210 Table 2, RSS GEN Table 1 and RSS 310 Table 3. Note that receivers operating outside of the frequency range 30 MHz – 960 MHz are exempt from the requirements of 15.109.

Frequency Range (MHz)	Limit (uV/m @ 3m)	Limit (dBuV/m @ 3m)
30 to 88	100	40
88 to 216	150	43.5
216 to 960	200	46.0
Above 960	500	54.0

OUTPUT POWER LIMITS – DIGITAL TRANSMISSION SYSTEMS

The table below shows the limits for output power and output power density. Where the signal bandwidth is less than 20 MHz the maximum output power is reduced to the power spectral density limit plus 10 times the log of the bandwidth (in MHz).

Operating Frequency (MHz)	Output Power	Power Spectral Density
902 – 928	1 Watt (30 dBm)	8 dBm/3kHz
2400 – 2483.5	1 Watt (30 dBm)	8 dBm/3kHz
5725 – 5850	1 Watt (30 dBm)	8 dBm/3kHz

The maximum permitted output power is reduced by 1dB for every dB the antenna gain exceeds 6dBi. Fixed point-to-point applications using the 5725 – 5850 MHz band are not subject to this restriction.

¹ The restricted bands are detailed in FCC 15.203, RSS 210 Table 1 and RSS 310 Table 2

TRANSMIT MODE SPURIOUS RADIATED EMISSIONS LIMITS – FHSS and DTS SYSTEMS

The limits for unwanted (spurious) emissions from the transmitter falling in the restricted bands are those specified in the general limits sections of FCC Part 15 and RSS 210. All other unwanted (spurious) emissions shall be at least 20dB below the level of the highest in-band signal level (30dB if the power is measured using the sample detector/power averaging method).

SAMPLE CALCULATIONS - CONDUCTED EMISSIONS

Receiver readings are compared directly to the conducted emissions specification limit (decibel form) as follows:

$$R_r - S = M$$

where:

R_r = Receiver Reading in dBuV

S = Specification Limit in dBuV

M = Margin to Specification in +/- dB

SAMPLE CALCULATIONS - RADIATED EMISSIONS

Receiver readings are compared directly to the specification limit (decibel form). The receiver internally corrects for cable loss, preamplifier gain, and antenna factor. The calculations are in the reverse direction of the actual signal flow, thus cable loss is added and the amplifier gain is subtracted. The Antenna Factor converts the voltage at the antenna coaxial connector to the field strength at the antenna elements.

A distance factor, when used for electric field measurements above 30MHz, is calculated by using the following formula:

$$F_d = 20 * \text{LOG}_{10} (D_m/D_s)$$

where:

F_d = Distance Factor in dB

D_m = Measurement Distance in meters

D_s = Specification Distance in meters

For electric field measurements below 30MHz the extrapolation factor is either determined by making measurements at multiple distances or a theoretical value is calculated using the formula:

$$F_d = 40 * \text{LOG}_{10} (D_m/D_s)$$

Measurement Distance is the distance at which the measurements were taken and Specification Distance is the distance at which the specification limits are based. The antenna factor converts the voltage at the antenna coaxial connector to the field strength at the antenna elements.

The margin of a given emission peak relative to the limit is calculated as follows:

$$R_c = R_r + F_d$$

and

$$M = R_c - L_s$$

where:

$$R_r = \text{Receiver Reading in dBuV/m}$$

$$F_d = \text{Distance Factor in dB}$$

$$R_c = \text{Corrected Reading in dBuV/m}$$

$$L_s = \text{Specification Limit in dBuV/m}$$

$$M = \text{Margin in dB Relative to Spec}$$

SAMPLE CALCULATIONS - FIELD STRENGTH TO EIRP CONVERSION

Where the radiated electric field strength is expressed in terms of the equivalent isotropic radiated power (eirp), or where a field strength measurement of output power is made in lieu of a direct measurement, the following formula is used to convert between eirp and field strength at a distance of d (meters) from the equipment under test:

$$E = \frac{1000000 \sqrt{30 P}}{d} \quad \text{microvolts per meter}$$

where P is the eirp (Watts)

For a measurement at 3m the conversion from a logarithmic value for field strength (dBuV/m) to an eirp power (dBm) is -95.3dB.

Appendix A Test Equipment Calibration Data**Radio Antenna Port (Power and Spurious Emissions), 05-Jun-14**

<u>Manufacturer</u>	<u>Description</u>	<u>Model</u>	<u>Asset #</u>	<u>Cal Due</u>
Rohde & Schwarz	EMI Test Receiver, 20 Hz-7 GHz	ESIB7	1538	12/14/2014

Radiated Spurious Emissions, Bandedges, 2.4 GHz, 06-Jun-14

<u>Manufacturer</u>	<u>Description</u>	<u>Model</u>	<u>Asset #</u>	<u>Cal Due</u>
EMCO	Antenna, Horn, 1-18 GHz (SA40-Red)	3115	1142	8/23/2014
Rohde & Schwarz	EMI Test Receiver, 20 Hz-7 GHz	ESIB7	1538	12/14/2014

Radiated Spurious Emissions, Bandedges, 2.4 GHz, 09-Jun-14

<u>Manufacturer</u>	<u>Description</u>	<u>Model</u>	<u>Asset #</u>	<u>Cal Due</u>
EMCO	Antenna, Horn, 1-18 GHz (SA40-Red)	3115	1142	8/23/2014
Rohde & Schwarz	EMI Test Receiver, 20 Hz-7 GHz	ESIB7	1538	12/14/2014

Radiated Spurious Emissions, Bandedges, 2.4 GHz, 10-Jun-14

<u>Manufacturer</u>	<u>Description</u>	<u>Model</u>	<u>Asset #</u>	<u>Cal Due</u>
EMCO	Antenna, Horn, 1-18 GHz (SA40-Red)	3115	1142	8/23/2014
Rohde & Schwarz	EMI Test Receiver, 20 Hz-7 GHz	ESIB7	1538	12/14/2014

Radiated Spurious Emissions, 1000 - 25,000 MHz, 11-Jun-14

<u>Manufacturer</u>	<u>Description</u>	<u>Model</u>	<u>Asset #</u>	<u>Cal Due</u>
EMCO	Antenna, Horn, 1-18 GHz (SA40-Red)	3115	1142	8/23/2014
Hewlett Packard	SpecAn 9 kHz - 40 GHz, FT (SA40) Blue	8564E (84125C)	1393	5/6/2015
Rohde & Schwarz	EMI Test Receiver, 20 Hz-7 GHz	ESIB7	1538	12/14/2014
Hewlett Packard	Microwave Preamplifier, 1- 26.5GHz	8449B	1780	11/26/2014
Micro-Tronics	Band Reject Filter, 2400-2500 MHz	BRM50702-02	2249	10/3/2014

Radiated Emissions, 1,000 - 6,500 MHz and 18,000 - 26,000MHz, 12-Jun-14

<u>Manufacturer</u>	<u>Description</u>	<u>Model</u>	<u>Asset #</u>	<u>Cal Due</u>
Hewlett Packard	SpecAn 9 kHz - 40 GHz, FT (SA40) Blue	8564E (84125C)	1393	5/6/2015
Rohde & Schwarz	EMI Test Receiver, 20 Hz-7 GHz	ESIB7	1538	12/14/2014
EMCO	Antenna, Horn, 1-18 GHz	3115	1561	7/12/2014
Hewlett Packard	Head (Inc flex cable, (1742,1743) Blue)	84125C	1620	5/6/2015
Hewlett Packard	HF Amplifier, 45 MHz -50 GHz (with 1620)	83051A (84125C)	1742	5/6/2015
Hewlett Packard	HF Amplifier, 45 MHz -50 GHz (with 1620)	83051A (84125C)	1743	5/6/2015
A. H. Systems	Purple System Horn, 18-40GHz	SAS-574, p/n: 2581	2160	6/28/2014

Radiated Emissions, 1,000 - 26,000 MHz, 16-Jun-14

<u>Manufacturer</u>	<u>Description</u>	<u>Model</u>	<u>Asset #</u>	<u>Cal Due</u>
Hewlett Packard	SpecAn 9 KHz-26.5 GHz, Non-Program	8563E	284	2/26/2015
EMCO	Antenna, Horn, 1-18 GHz	3115	786	12/20/2015
Hewlett Packard	Microwave Preamplifier, 1-26.5GHz	8449B	870	2/20/2015
Micro-Tronics	Band Reject Filter, 2400-2500 MHz	BRM50702-02	1683	8/2/2014

Radiated Emissions, 1,000 - 6,000 MHz, 16-Jun-14

<u>Manufacturer</u>	<u>Description</u>	<u>Model</u>	<u>Asset #</u>	<u>Cal Due</u>
EMCO	Antenna, Horn, 1-18 GHz	3115	786	12/20/2015
Rohde & Schwarz	EMI Test Receiver, 20 Hz-7 GHz	ESIB7	1538	12/14/2014

Radiated Emissions, 1,000 - 18,000 MHz, 16-Jun-14

<u>Manufacturer</u>	<u>Description</u>	<u>Model</u>	<u>Asset #</u>	<u>Cal Due</u>
Hewlett Packard	SpecAn 9 KHz-26.5 GHz, Non-Program	8563E	284	2/26/2015
EMCO	Antenna, Horn, 1-18 GHz	3115	786	12/20/2015
Hewlett Packard	Microwave Preamplifier, 1-26.5GHz	8449B	870	2/20/2015
Micro-Tronics	Band Reject Filter, 2400-2500 MHz	BRM50702-02	1683	8/2/2014

Radiated Emissions, 18,000 - 26,500 MHz, 17-Jun-14

<u>Manufacturer</u>	<u>Description</u>	<u>Model</u>	<u>Asset #</u>	<u>Cal Due</u>
Hewlett Packard	SpecAn 9 kHz - 40 GHz, FT (SA40) Blue	8564E (84125C)	1393	5/6/2015
Hewlett Packard	HF Amplifier, 45 MHz -50 GHz (with 1620)	83051A (84125C)	1742	5/6/2015
Hewlett Packard	HF Amplifier, 45 MHz -50 GHz (with 1620)	83051A (84125C)	1743	5/6/2015
A. H. Systems	Purple System Horn, 18-40GHz	SAS-574, p/n: 2581	2160	6/28/2014

Radio Antenna Port (Power and Spurious Emissions), 17-Jun-14

<u>Manufacturer</u>	<u>Description</u>	<u>Model</u>	<u>Asset #</u>	<u>Cal Due</u>
Agilent Technologies	PSA, Spectrum Analyzer, (installed options, 111, 115, 123, 1DS, B7J, HYX,	E4446A	2139	4/8/2015
Agilent Technologies	USB Average Power Sensor	U2001A	2442	12/19/2014

Radio Antenna Port (Power and Spurious Emissions), 18-Jun-14

<u>Manufacturer</u>	<u>Description</u>	<u>Model</u>	<u>Asset #</u>	<u>Cal Due</u>
Rohde & Schwarz	Power Meter, Single Channel	NRVS	1422	1/24/2015
Rohde & Schwarz	Power Sensor 100 uW - 2 Watts use with 20dB attenuator sn:1031.6959.00 only	NRV-Z32	1423	9/17/2014
Agilent Technologies	PSA, Spectrum Analyzer, (installed options, 111, 115, 123, 1DS, B7J, HYX,	E4446A	2139	4/8/2015

Radio Antenna Port (Power and Spurious Emissions), 19-Jun-14

<u>Manufacturer</u>	<u>Description</u>	<u>Model</u>	<u>Asset #</u>	<u>Cal Due</u>
Rohde & Schwarz	Power Sensor, 1 uW-100 mW, DC-18 GHz, 50ohms	NRV-Z51	1070	6/6/2015
Rohde & Schwarz	Power Meter, Dual Channel	NRVD	1071	3/24/2015
Rohde & Schwarz	Power Sensor 100 uW - 2 Watts use with 20dB attenuator sn:1031.6959.00 only	NRV-Z32	1423	9/17/2014
Agilent Technologies	PSA, Spectrum Analyzer, (installed options, 111, 115, 123, 1DS, B7J, HYX,	E4446A	2139	4/8/2015

Radio Antenna Port (Power and Spurious Emissions), 20-Jun-14

<u>Manufacturer</u>	<u>Description</u>	<u>Model</u>	<u>Asset #</u>	<u>Cal Due</u>
Rohde & Schwarz	Power Meter, Dual Channel	NRVD	1071	3/24/2015
Rohde & Schwarz	Power Sensor 100 uW - 2 Watts use with 20dB attenuator sn:1031.6959.00 only	NRV-Z32	1423	9/17/2014
Agilent Technologies	PSA, Spectrum Analyzer, (installed options, 111, 115, 123, 1DS, B7J, HYX,	E4446A	2139	4/8/2015

Appendix B Test Data

T95471 Pages 25 – 166

T95472 Pages 167 - 209



EMC Test Data

Client:	Intel Corporation	Job Number:	J94914
Product:	7265D2W	T-Log Number:	T95471
		Project Manager:	Christine Krebill
Contact:	Steve Hackett	Project Coordinator:	-
Emissions Standard(s):	FCC Part 15.247, 15.407, RSS-210	Class:	B
Immunity Standard(s):	-	Environment:	Radio

EMC Test Data

For The

Intel Corporation

Product

7265D2W

Date of Last Test: 7/10/2014



EMC Test Data

Client: Intel Corporation	Job Number: J94914
Model: 7265D2W	T-Log Number: T95471
	Project Manager: Christine Krebill
Contact: Steve Hackett	Project Coordinator: -
Standard: FCC Part 15.247, 15.407, RSS-210	Class: N/A

Power vs. Data Rate

In normal operating modes the card uses power settings stored on EEPROM to set the output power. For a given nominal output power the actual transmit power normally is reduced as the data rate increases, therefore testing was performed at the data rate in the mode with highest power to determine compliance with the requirements.

The following power measurements were made using a GATED average power meter and with the device configured in a continuous transmit mode on Chain 1 at the various data rates in each mode to verify the highest power mode:

Sample Notes

MAC Address: 001500F15B5D DRTU Tool Version 1.7.3-935 Driver version 17.1.0.11
 BT Address: 001500F15B61 DRTU Tool Version 1.7.3-935 Driver version 17.1.0.11

Date of Test: 6/5/2014
 Test Engineer: John Caizzi
 Test Location: Lab 4

Insertion loss of cable = .4 dB at 2.4 GHz.

Mode	Data Rate	Power (dBm)	Power setting
802.11b	1	9.7	7.0
	2	9.6	
	5.5	9.5	
	11	9.4	
802.11g	6	4.6	7.0
	9	4.5	
	12	4.5	
	18	4.4	
	24	4.3	
	36	4.3	
	48	4.2	
	54	4.2	



EMC Test Data

Client: Intel Corporation	Job Number: J94914
Model: 7265D2W	T-Log Number: T95471
	Project Manager: Christine Krebill
Contact: Steve Hackett	Project Coordinator: -
Standard: FCC Part 15.247, 15.407, RSS-210	Class: N/A

Mode	Data Rate	Power (dBm)	Power setting
802.11n 20MHz	HT0	4.6	7.0
	HT1	4.5	
	HT2	4.5	
	HT3	4.4	
	HT4	4.2	
	HT5	4.1	
	HT6	4.2	
802.11n/ac 40MHz	HT0	4.4	7.0
	HT1	4.3	
	HT2	4.2	
	HT3	4.1	
	HT4	4.0	
	HT5	3.9	
	HT6	3.9	
	HT7	3.9	

Note : Power setting - the software power setting used during testing, included for reference only.



EMC Test Data

Client:	Intel Corporation	Job Number:	J94914
Model:	7265D2W	T-Log Number:	T95471
		Project Manager:	Christine Krebill
Contact:	Steve Hackett	Project Coordinator:	-
Standard:	FCC Part 15.247, 15.407, RSS-210	Class:	N/A

Duty Cycle

Date of Test: 6/5/14 & 6/12/14
 Test Engineer: John Caizzi
 Test Location: Lab 4 / Chamber 7

Duty cycle measurements performed on the worse case data rate for power.

Notes: Measurements taken with maximum RBW/VBW settings allowed.

Mode	Data Rate	Duty Cycle (x)	Constant DC?	T (ms)	Pwr Cor Factor*	Lin Volt Cor Factor**	Min VBW for FS (Hz)
11b	1	0.99	Yes	2.272	0.0	0.0	440
11g	6	0.99	Yes	2.06	0.0	0.0	485
n20	HT0	0.99	Yes	1.919	0.0	0.0	521
n40	HT0	0.97	Yes	0.944	0.1	0.2	1059
BT basic	-	0.77	Yes	2.906	1.1	2.2	344
BT EDR	-	0.77	Yes	2.885	1.1	2.3	347
BTLE	-	0.63	Yes	0.391	2.0	3.9	2558

* Correction factor when using RMS/Power averaging - $10 \cdot \log(1/x)$

** Correction factor when using linear voltage average - $20 \cdot \log(1/x)$

T = Minimum transmission duration

Client: Intel Corporation	Job Number: J94914
Model: 7265D2W	T-Log Number: T95471
Contact: Steve Hackett	Project Manager: Christine Krebill
Standard: FCC Part 15.247, 15.407, RSS-210	Project Coordinator: -
	Class: N/A

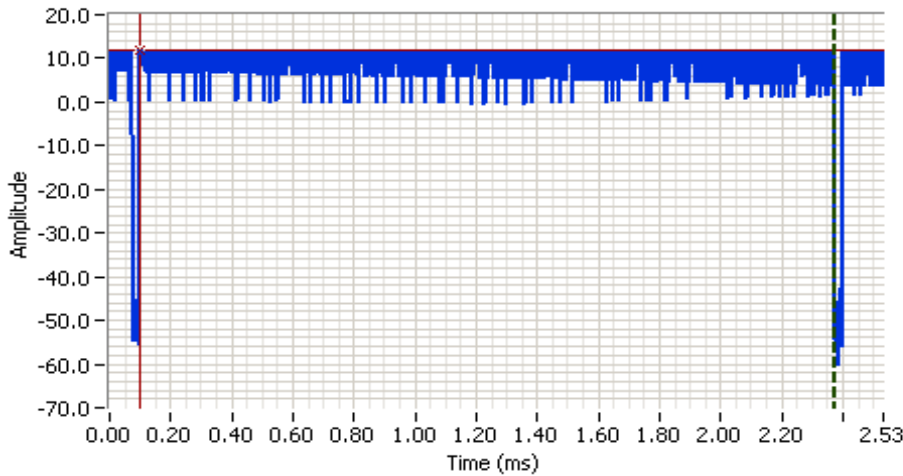

Analyzer Settings
 Agilent Technologies, E4446A
 CF: 2437.000 MHz
 SPAN: 0.000 MHz
 RB: 8.000 MHz
 VB: 50.000 MHz
 Detector: POS
 Attn: 30 DB
 RL Offset: 0.0 DB
 Sweep Time: 2.5ms
 Ref Lvl: 20.0 DBM

Comments
 11b, on time = 2.272 ms

Cursor 1	2.3738	21.28	Delta Time (ms)	2.272
Cursor 2	0.1019	11.78	Delta Amplitude	9.50

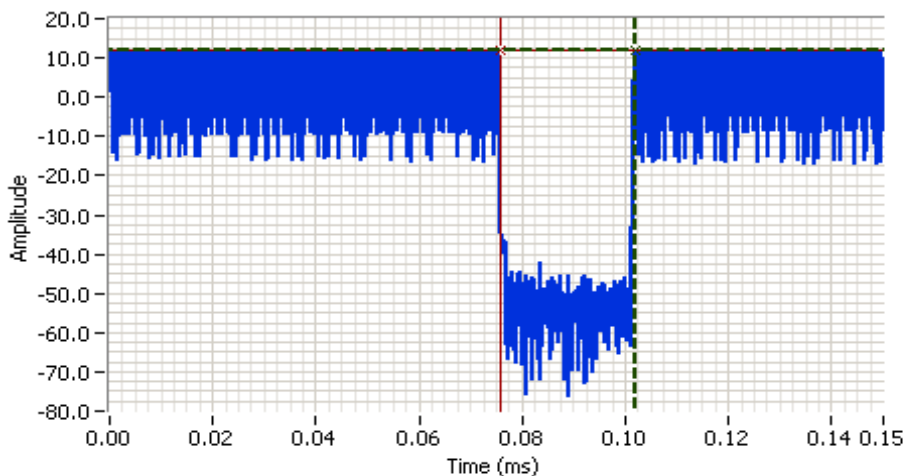

Analyzer Settings
 Agilent Technologies, E4446A
 CF: 2437.000 MHz
 SPAN: 0.000 MHz
 RB: 8.000 MHz
 VB: 50.000 MHz
 Detector: POS
 Attn: 30 DB
 RL Offset: 0.0 DB
 Sweep Time: 150.0us
 Ref Lvl: 20.0 DBM

Comments
 11b, off time = .026 ms

Cursor 1	0.1020	12.08	Delta Time (ms)	0.026
Cursor 2	0.0758	12.08	Delta Amplitude	0.00



Client: Intel Corporation	Job Number: J94914
Model: 7265D2W	T-Log Number: T95471
Contact: Steve Hackett	Project Manager: Christine Krebill
Standard: FCC Part 15.247, 15.407, RSS-210	Project Coordinator: -
	Class: N/A

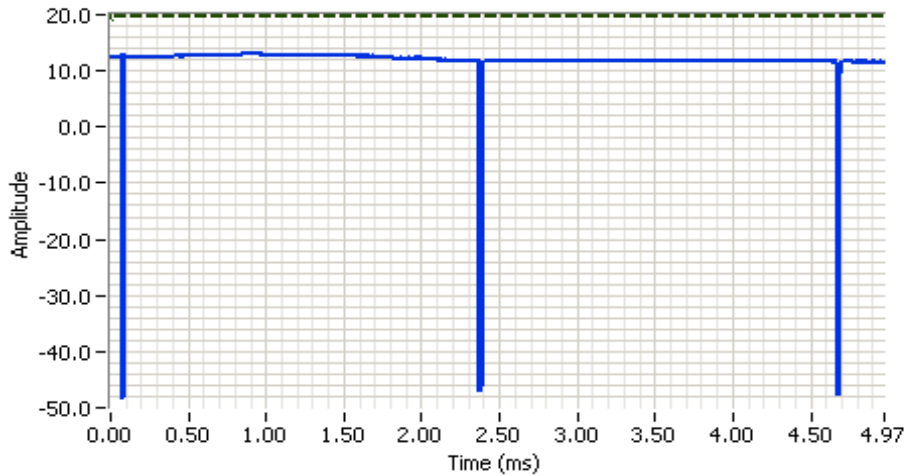

Analyzer Settings
 Agilent Technologies, E4446A
 CF: 2437.000 MHz
 SPAN: 0.000 MHz
 RB: 8.000 MHz
 VB: 50.000 MHz
 Detector: POS
 Attn: 30 DB
 RL Offset: 0.0 DB
 Sweep Time: 5.1ms
 Ref Lvl: 20.0 DBM

Comments
 11b, constant duty cycle

Cursor 1 -0.0132 19.67 [Move] [Lock] [Close]

 0.0000 0.00 [Move] [Lock] [Close]

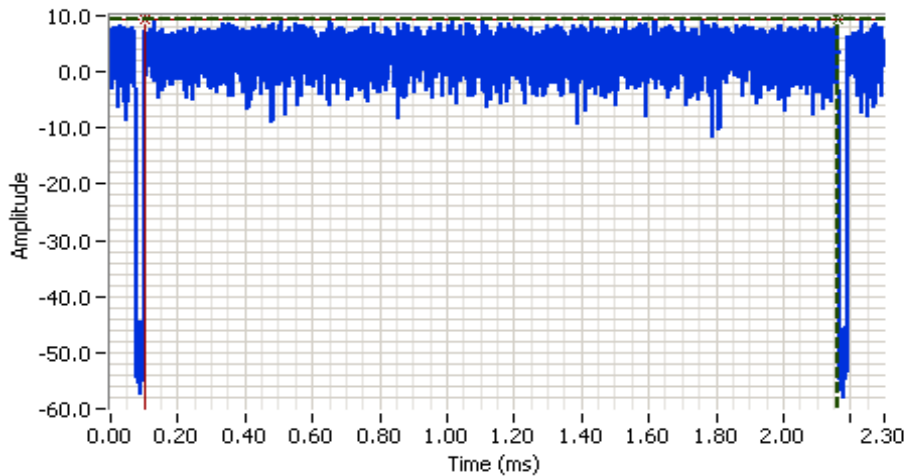

Analyzer Settings
 Agilent Technologies, E4446A
 CF: 2437.000 MHz
 SPAN: 0.000 MHz
 RB: 8.000 MHz
 VB: 50.000 MHz
 Detector: POS
 Attn: 30 DB
 RL Offset: 0.0 DB
 Sweep Time: 2.3ms
 Ref Lvl: 20.0 DBM

Comments
 11g, on time = 2.060 ms

Cursor 1 2.1622 9.41 [Move] [Lock] [Close] Delta Time (ms) 2.060

Cursor 2 0.1018 9.41 [Move] [Lock] [Close] Delta Amplitude 0.00



Client: Intel Corporation	Job Number: J94914
Model: 7265D2W	T-Log Number: T95471
Contact: Steve Hackett	Project Manager: Christine Krebill
Standard: FCC Part 15.247, 15.407, RSS-210	Project Coordinator: -
	Class: N/A

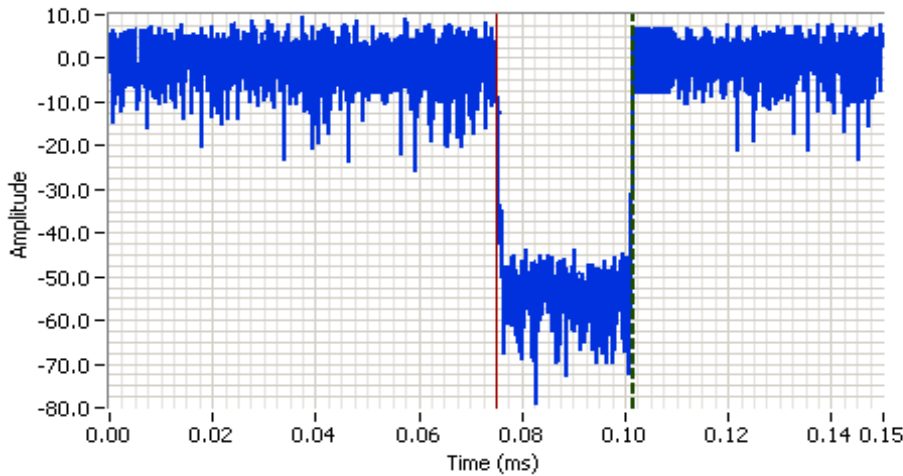

Analyzer Settings
 Agilent Technologies, E4446A
 CF: 2437.000 MHz
 SPAN: 0.000 MHz
 RB: 8.000 MHz
 VB: 50.000 MHz
 Detector: POS
 Attn: 30 DB
 RL Offset: 0.0 DB
 Sweep Time: 150.0us
 Ref Lvl: 20.0 DBM

Comments
 11g, off time = .027 ms

Cursor 1 0.1016 12.13 Delta Time (ms) 0.027
 Cursor 2 0.0750 12.13 Delta Amplitude 0.00

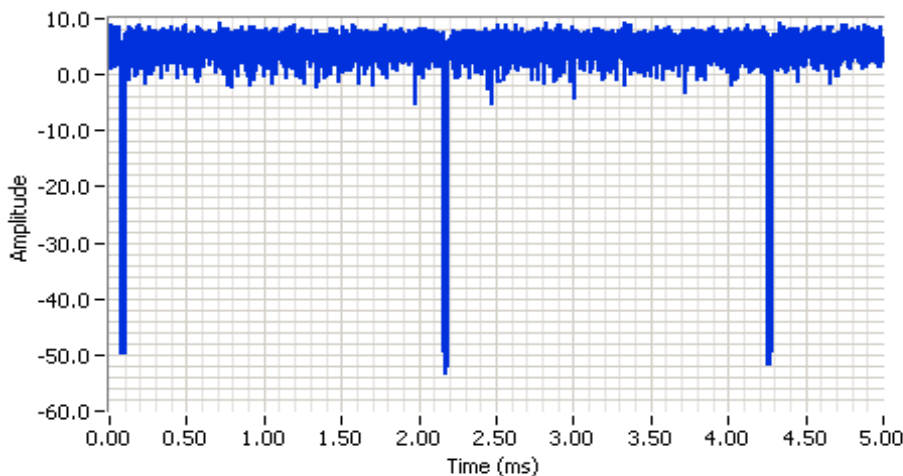

Analyzer Settings
 Agilent Technologies, E4446A
 CF: 2437.000 MHz
 SPAN: 0.000 MHz
 RB: 8.000 MHz
 VB: 50.000 MHz
 Detector: POS
 Attn: 30 DB
 RL Offset: 0.0 DB
 Sweep Time: 5.0ms
 Ref Lvl: 20.0 DBM

Comments
 11g, constant duty cycle

Cursor 1 -0.8073 13.32 Delta Time (ms) 0.234
 Cursor 2 -0.5729 12.65 Delta Amplitude 0.66



Client: Intel Corporation	Job Number: J94914
Model: 7265D2W	T-Log Number: T95471
Contact: Steve Hackett	Project Manager: Christine Krebill
Standard: FCC Part 15.247, 15.407, RSS-210	Project Coordinator: -
	Class: N/A

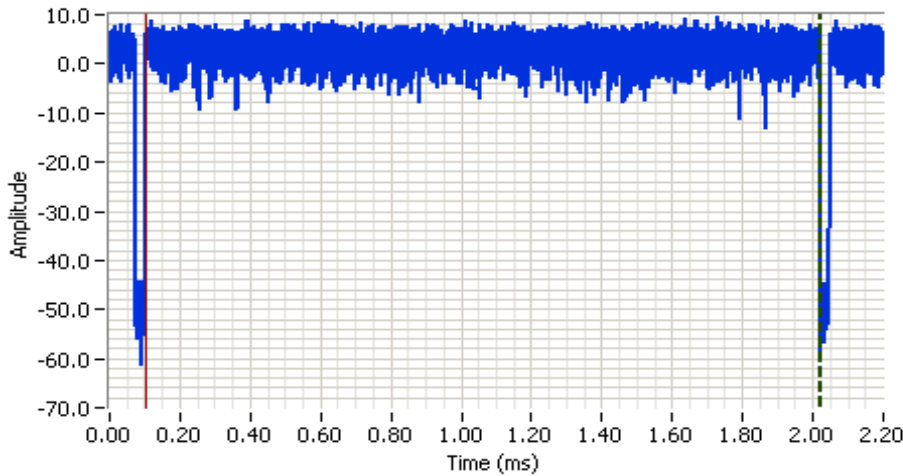

Analyzer Settings
 Agilent Technologies, E4446A
 CF: 2437.000 MHz
 SPAN: 0.000 MHz
 RB: 8.000 MHz
 VB: 50.000 MHz
 Detector: POS
 Attn: 30 DB
 RL Offset: 0.0 DB
 Sweep Time: 2.2ms
 Ref Lvl: 20.0 DBM

Comments
 n20, on time = 1.919 ms

Cursor 1	2.0224	12.27	Delta Time (ms)	1.919
Cursor 2	0.1031	11.90	Delta Amplitude	0.38

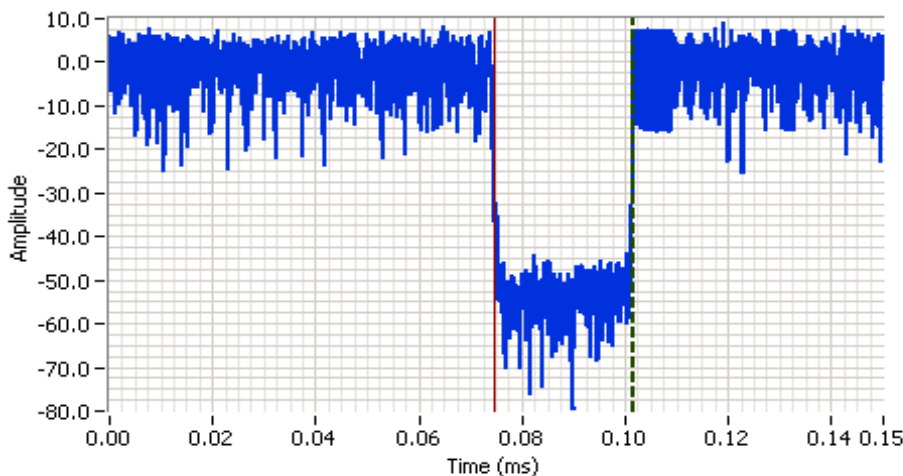

Analyzer Settings
 Agilent Technologies, E4446A
 CF: 2437.000 MHz
 SPAN: 0.000 MHz
 RB: 8.000 MHz
 VB: 50.000 MHz
 Detector: POS
 Attn: 30 DB
 RL Offset: 0.0 DB
 Sweep Time: 150.0us
 Ref Lvl: 20.0 DBM

Comments
 n20, off time = .027 ms

Cursor 1	0.1016	12.13	Delta Time (ms)	0.027
Cursor 2	0.0746	12.99	Delta Amplitude	0.85



Client: Intel Corporation	Job Number: J94914
Model: 7265D2W	T-Log Number: T95471
Contact: Steve Hackett	Project Manager: Christine Krebill
Standard: FCC Part 15.247, 15.407, RSS-210	Project Coordinator: -
	Class: N/A

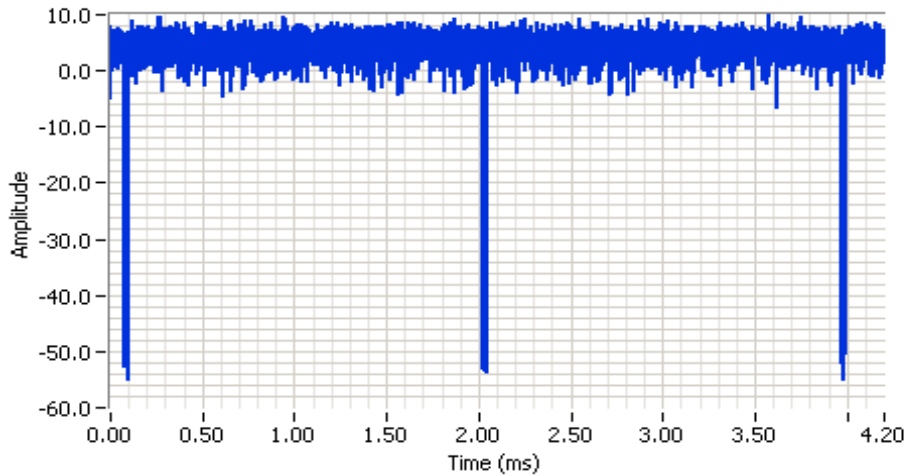

Analyzer Settings
 Agilent Technologies, E4446A
 CF: 2437.000 MHz
 SPAN: 0.000 MHz
 RB: 8.000 MHz
 VB: 50.000 MHz
 Detector: POS
 Attn: 30 DB
 RL Offset: 0.0 DB
 Sweep Time: 4.2ms
 Ref Lvl: 20.0 DBM

Comments
 n20, constant duty cycle

Cursor 1 4.5172 14.31 Delta Time (ms) 0.142

Cursor 2 4.3750 12.32 Delta Amplitude 1.99

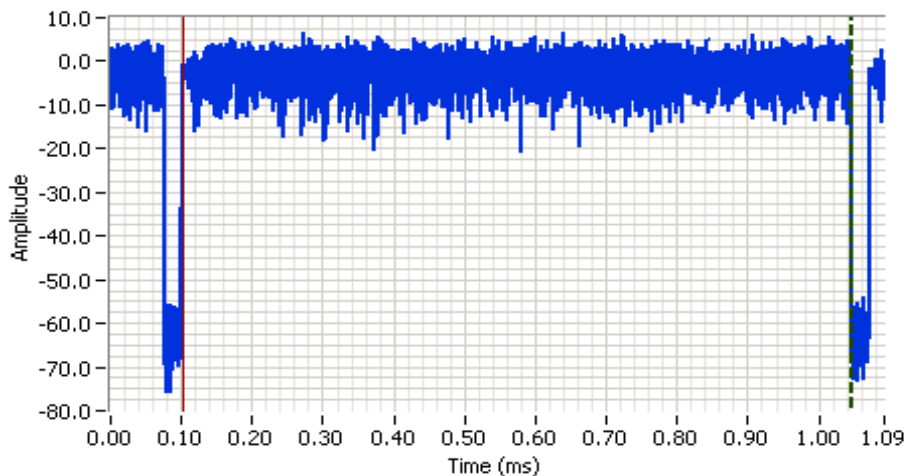

Analyzer Settings
 Agilent Technologies, E4446A
 CF: 2437.000 MHz
 SPAN: 0.000 MHz
 RB: 8.000 MHz
 VB: 50.000 MHz
 Detector: POS
 Attn: 20 DB
 RL Offset: 0.0 DB
 Sweep Time: 1.1ms
 Ref Lvl: 10.0 DBM

Comments
 n40, on time = .944 ms

Cursor 1 1.0466 12.99 Delta Time (ms) 0.944

Cursor 2 0.1024 12.56 Delta Amplitude 0.43



Client: Intel Corporation	Job Number: J94914
Model: 7265D2W	T-Log Number: T95471
Contact: Steve Hackett	Project Manager: Christine Krebill
Standard: FCC Part 15.247, 15.407, RSS-210	Project Coordinator: -
	Class: N/A

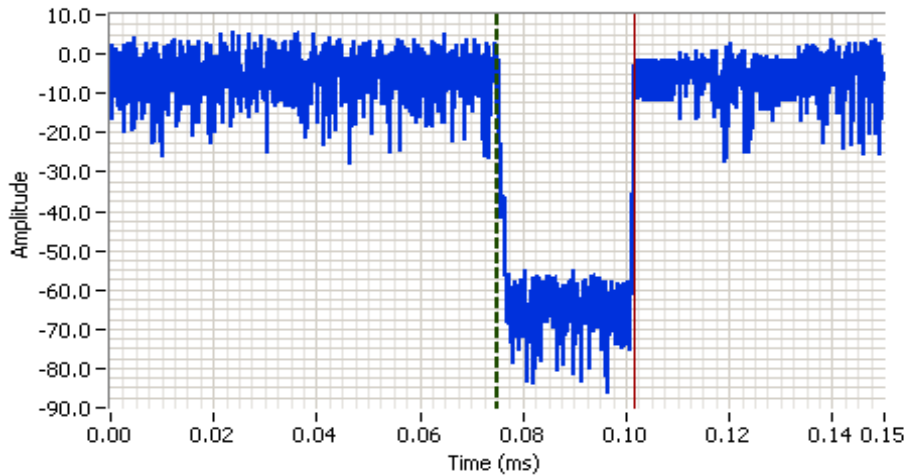

Analyzer Settings
 Agilent Technologies, E4446A
 CF: 2437.000 MHz
 SPAN: 0.000 MHz
 RB: 8.000 MHz
 VB: 50.000 MHz
 Detector: POS
 Attn: 20 DB
 RL Offset: 0.0 DB
 Sweep Time: 150.0us
 Ref Lvl: 10.0 DBM

Comments
 n40, off time = .027 ms

Cursor 1	0.0750	11.42	⊕ ⊖ 🔒	Delta Time (ms)	0.027
Cursor 2	0.1016	12.37	⊕ ⊖ 🔒	Delta Amplitude	0.95

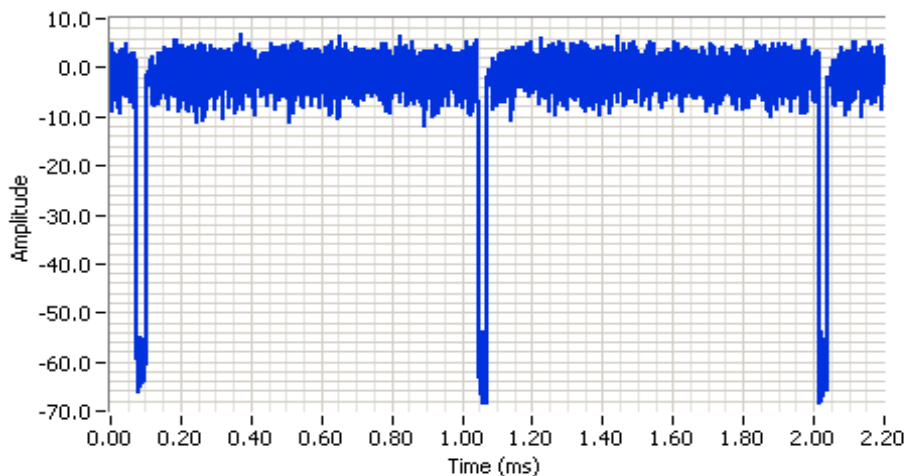

Analyzer Settings
 Agilent Technologies, E4446A
 CF: 2437.000 MHz
 SPAN: 0.000 MHz
 RB: 8.000 MHz
 VB: 50.000 MHz
 Detector: POS
 Attn: 20 DB
 RL Offset: 0.0 DB
 Sweep Time: 2.2ms
 Ref Lvl: 10.0 DBM

Comments
 n40, constant duty cycle

Cursor 1	-0.0802	13.79	⊕ ⊖ 🔒	Delta Time (ms)	0.017
Cursor 2	-0.0974	13.03	⊕ ⊖ 🔒	Delta Amplitude	0.76



Client: Intel Corporation	Job Number: J94914
Model: 7265D2W	T-Log Number: T95471
Contact: Steve Hackett	Project Manager: Christine Krebill
Standard: FCC Part 15.247, 15.407, RSS-210	Project Coordinator: -
	Class: N/A

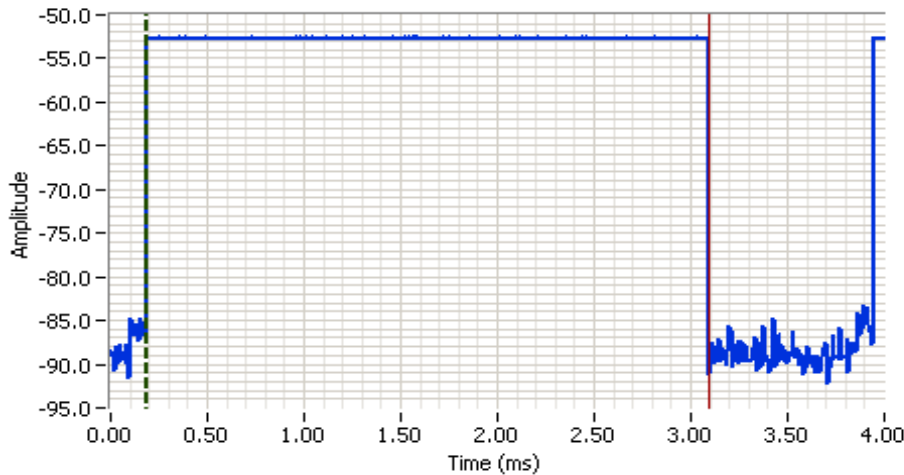

Analyzer Settings
 Rohde&Schwarz,ESI
 CF: 2441.000 MHz
 SPAN: 0.000 MHz
 RB: 10.000 MHz
 VB: 10.000 MHz
 Detector: POS
 Attn: 0 DB
 RL Offset: 0.0 DB
 Sweep Time: 4.0ms
 Ref Lvl: -35.0 DBM

Comments
 BT basic DHS PRBS
 On time = 2.906 ms

Cursor 1	0.1875	-48.29	Delta Time (ms)	2.906
Cursor 2	3.0937	-47.44	Delta Amplitude	0.85

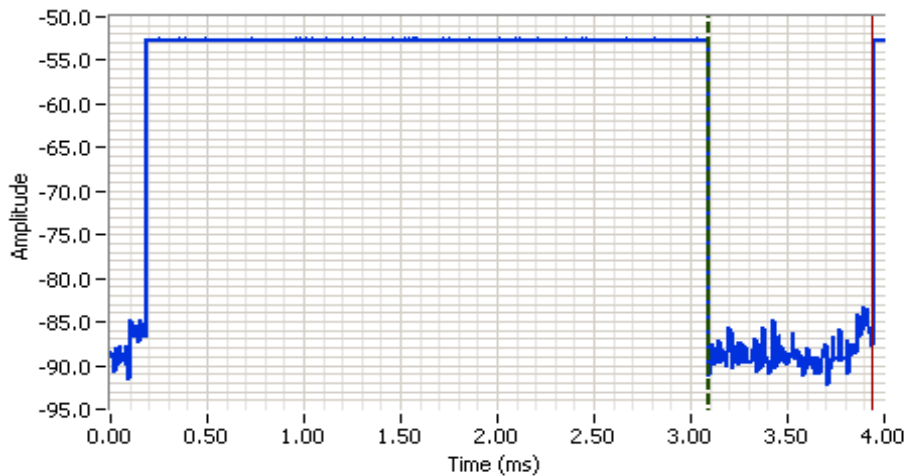

Analyzer Settings
 Rohde&Schwarz,ESI
 CF: 2441.000 MHz
 SPAN: 0.000 MHz
 RB: 10.000 MHz
 VB: 10.000 MHz
 Detector: POS
 Attn: 0 DB
 RL Offset: 0.0 DB
 Sweep Time: 4.0ms
 Ref Lvl: -35.0 DBM

Comments
 BT basic DHS PRBS
 Off time = .844 ms

Cursor 1	3.0937	-48.29	Delta Time (ms)	0.844
Cursor 2	3.9375	-47.44	Delta Amplitude	0.85



Client: Intel Corporation	Job Number: J94914
Model: 7265D2W	T-Log Number: T95471
Contact: Steve Hackett	Project Manager: Christine Krebill
Standard: FCC Part 15.247, 15.407, RSS-210	Project Coordinator: -
	Class: N/A

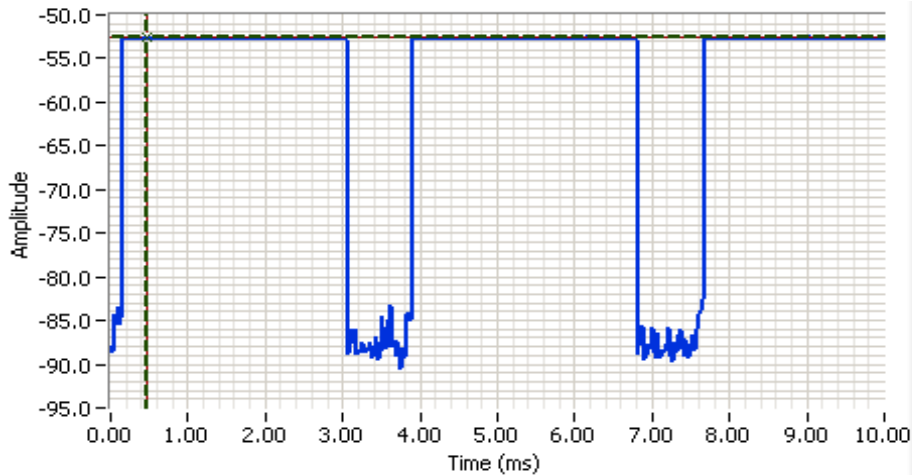

Analyzer Settings
 Rohde&Schwarz,ESI
 CF: 2441.000 MHz
 SPAN: 0.000 MHz
 RB: 10.000 MHz
 VB: 10.000 MHz
 Detector: POS
 Attn: 0 DB
 RL Offset: 0.0 DB
 Sweep Time: 10.0ms
 Ref Lvl: -35.0 DBM

Comments
 BT basic DHS PRBS
 constant duty cycle

Cursor 1	0.4810	-52.58		Delta Time (ms)	0.000
Cursor 2	0.4810	-52.58		Delta Amplitude	0.00

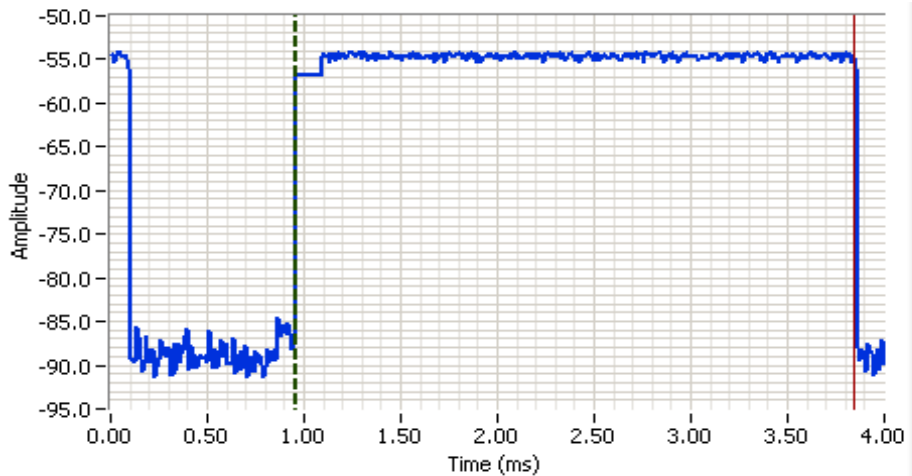

Analyzer Settings
 Rohde&Schwarz,ESI
 CF: 2441.000 MHz
 SPAN: 0.000 MHz
 RB: 10.000 MHz
 VB: 10.000 MHz
 Detector: POS
 Attn: 0 DB
 RL Offset: 0.0 DB
 Sweep Time: 4.0ms
 Ref Lvl: -35.0 DBM

Comments
 BT EDR 3-DHS PRBS
 On time = 2.885 ms

Cursor 1	0.9583	-46.59		Delta Time (ms)	2.885
Cursor 2	3.8437	-48.29		Delta Amplitude	1.71



Client: Intel Corporation	Job Number: J94914
Model: 7265D2W	T-Log Number: T95471
Contact: Steve Hackett	Project Manager: Christine Krebill
Standard: FCC Part 15.247, 15.407, RSS-210	Project Coordinator: -
	Class: N/A

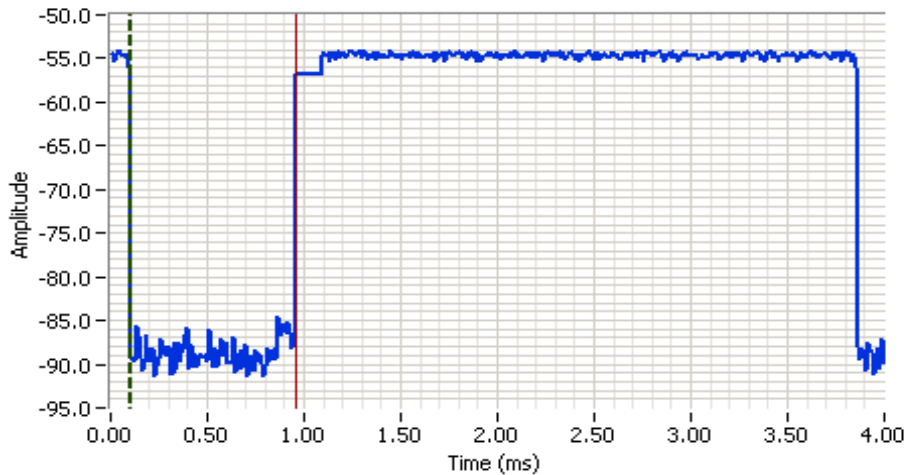

Analyzer Settings
 Rohde&Schwarz,ESI
 CF: 2441.000 MHz
 SPAN: 0.000 MHz
 RB: 10.000 MHz
 VB: 10.000 MHz
 Detector: POS
 Attn: 0 DB
 RL Offset: 0.0 DB
 Sweep Time: 4.0ms
 Ref Lvl: -35.0 DBM

Comments
 BT EDR 3-DH5 PRBS
 Off time = .854 ms

Cursor 1	0.1042	-46.59	Delta Time (ms)	0.854
Cursor 2	0.9583	-48.29	Delta Amplitude	1.71

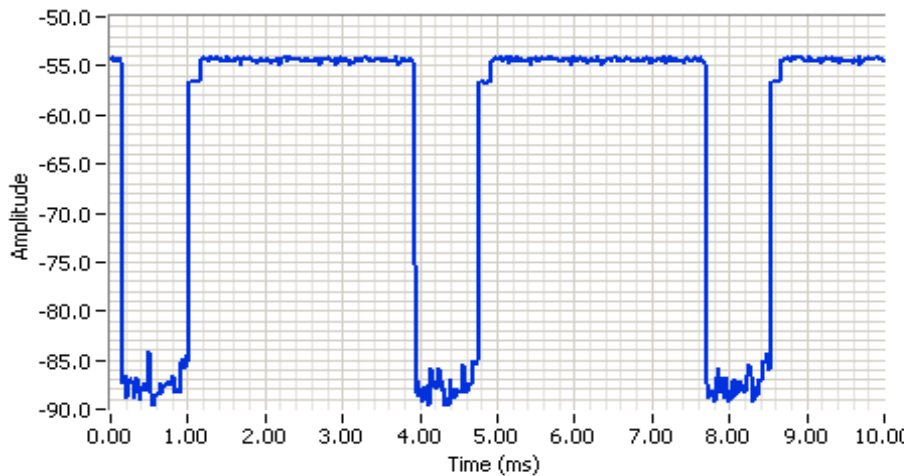

Analyzer Settings
 Rohde&Schwarz,ESI
 CF: 2441.000 MHz
 SPAN: 0.000 MHz
 RB: 10.000 MHz
 VB: 10.000 MHz
 Detector: POS
 Attn: 0 DB
 RL Offset: 0.0 DB
 Sweep Time: 10.0ms
 Ref Lvl: -35.0 DBM

Comments
 BT EDR 3-DH5 PRBS
 constant duty cycle

Cursor 1	11.0156	-48.29	Delta Time (ms)	0.703
Cursor 2	10.3125	-48.10	Delta Amplitude	0.19



Client: Intel Corporation	Job Number: J94914
Model: 7265D2W	T-Log Number: T95471
Contact: Steve Hackett	Project Manager: Christine Krebill
Standard: FCC Part 15.247, 15.407, RSS-210	Project Coordinator: -
	Class: N/A

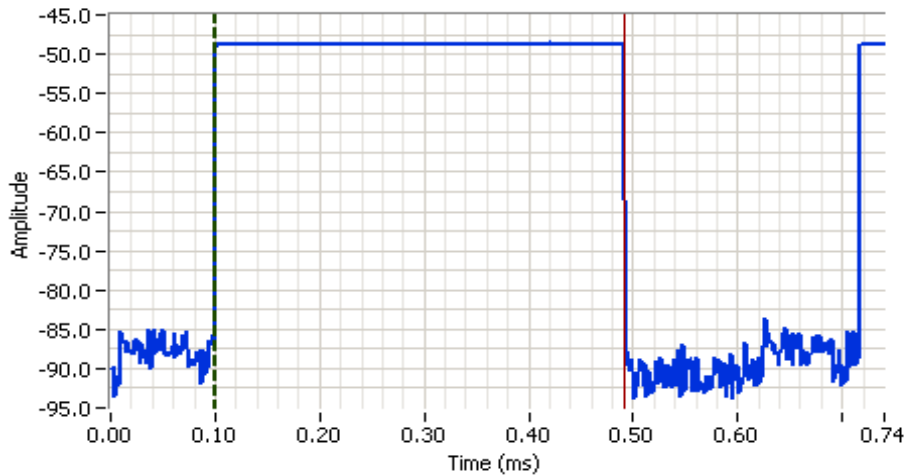

Analyzer Settings
 Rohde&Schwarz,ESI
 CF: 2442.000 MHz
 SPAN: 0.000 MHz
 RB: 10.000 MHz
 VB: 10.000 MHz
 Detector: POS
 Attn: 0 DB
 RL Offset: 0.0 DB
 Sweep Time: 0.7ms
 Ref Lvl: -35.0 DBM

Comments
 BTLE
 On time = .391 ms

Cursor 1 0.1002 -42.16 [Icons]
 Cursor 2 0.4914 -43.10 [Icons]
 Delta Time (ms) 0.391
 Delta Amplitude 0.95

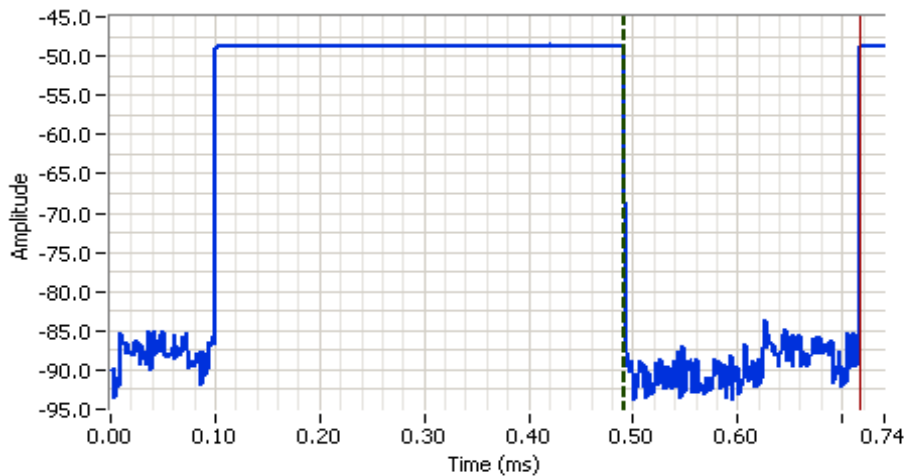

Analyzer Settings
 Rohde&Schwarz,ESI
 CF: 2442.000 MHz
 SPAN: 0.000 MHz
 RB: 10.000 MHz
 VB: 10.000 MHz
 Detector: POS
 Attn: 0 DB
 RL Offset: 0.0 DB
 Sweep Time: 0.7ms
 Ref Lvl: -35.0 DBM

Comments
 BTLE
 Off time = .225 ms

Cursor 1 0.4914 -42.16 [Icons]
 Cursor 2 0.7169 -43.10 [Icons]
 Delta Time (ms) 0.225
 Delta Amplitude 0.95





EMC Test Data

Client: Intel Corporation	Job Number: J94914
Model: 7265D2W	T-Log Number: T95471
Contact: Steve Hackett	Project Manager: Christine Krebill
Standard: FCC Part 15.247, 15.407, RSS-210	Project Coordinator: -
	Class: N/A

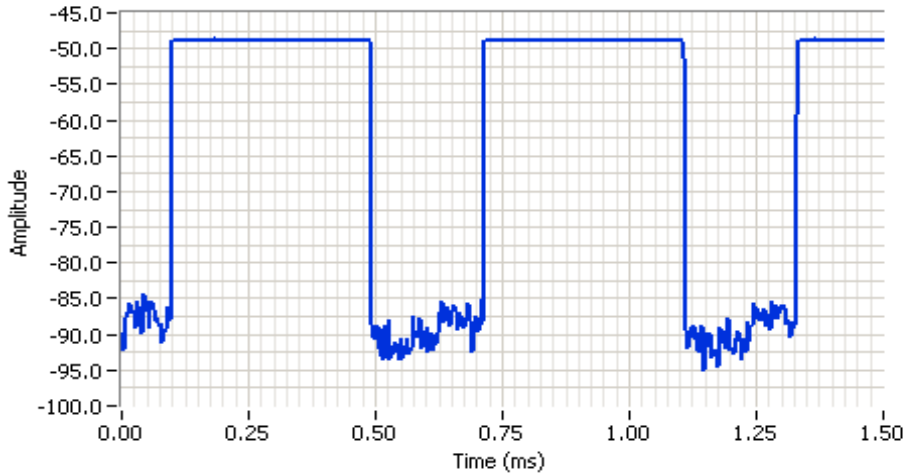

Analyzer Settings
Rohde&Schwarz,ESI
CF: 2442.000 MHz
SPAN: 0.000 MHz
RB: 10.000 MHz
VB: 10.000 MHz
Detector: POS
Attn: 0 DB
RL Offset: 0.0 DB
Sweep Time: 1.5ms
Ref Lvl: -35.0 DBM

Comments
BTLE, constant duty cycle

Cursor 1	-0.1429	-40.31	⊕ ⊖	Delta Time (ms)	0.067
Cursor 2	-0.2103	-42.91	⊕ ⊖	Delta Amplitude	2.61





EMC Test Data

Client: Intel Corporation	Job Number: J94914
Model: 7265D2W	T-Log Number: T95471
	Project Manager: Christine Krebill
Contact: Steve Hackett	Project Coordinator: -
Standard: FCC Part 15.247, 15.407, RSS-210	Class: N/A

RSS 210 and FCC 15.247 (DTS) Antenna Port Measurements Power, PSD, Bandwidth and Spurious Emissions

Test Specific Details

Objective: The objective of this test session is to perform final qualification testing of the EUT with respect to the specification listed above.

Date of Test: 6/18/2014
 Test Engineer: John Caizzi / Jack Liu
 Test Location: Lab 4A

Config. Used: 1
 Config Change: none
 EUT Voltage: 3.3Vdc

General Test Configuration

The EUT was connected to the spectrum analyzer or power meter via a suitable attenuator. All measurements were made on a single chain.
 All measurements have been corrected to allow for the external attenuators used.

Ambient Conditions: Temperature: 18-20 °C
 Rel. Humidity: 30-35 %

Summary of Results

Run #	Pwr setting	Avg Pwr	Test Performed	Limit	Pass / Fail	Result / Margin
1			Output Power	15.247(b)	Pass	b mode: 18.2 dBm g mode: 20.4 dBm n20 mode: 21.2 dBm n40 mode: 20.6 dBm
2			Power spectral Density (PSD)	15.247(d)	Pass	1.1 dBm/10kHz
3			Minimum 6dB Bandwidth	15.247(a)	Pass	10.043 MHz
3			99% Bandwidth	RSS GEN	-	36.16 MHz
4			Spurious emissions	15.247(b)	Pass	All emissions < -20 dBc

Modifications Made During Testing

No modifications were made to the EUT during testing

Deviations From The Standard

No deviations were made from the requirements of the standard.

Procedure Comments:

Measurements performed in accordance with FCC KDB 558074



EMC Test Data

Client:	Intel Corporation	Job Number:	J94914
Model:	7265D2W	T-Log Number:	T95471
		Project Manager:	Christine Krebill
Contact:	Steve Hackett	Project Coordinator:	-
Standard:	FCC Part 15.247, 15.407, RSS-210	Class:	N/A

Mode	Data Rate	Duty Cycle (x)	Constant DC?	T (ms)	Pwr Cor Factor*	Lin Volt Cor Factor**	Min VBW for FS (Hz)
11b	1	0.99	Yes	2.272	0.0	0.0	440
11g	6	0.99	Yes	2.06	0.0	0.0	485
n20	HT0	0.99	Yes	1.919	0.0	0.0	521
n40	HT0	0.97	Yes	0.944	0.1	0.2	1059

Sample Notes

MAC Address: 001500F15B5D DRTU Tool Version 1.7.3-935 Driver version 17.1.0.11



EMC Test Data

Client: Intel Corporation	Job Number: J94914
Model: 7265D2W	T-Log Number: T95471
Contact: Steve Hackett	Project Manager: Christine Krebill
Standard: FCC Part 15.247, 15.407, RSS-210	Project Coordinator: -
	Class: N/A

Run #1: Output Power

Mode: 11b

Power Setting ²	Frequency (MHz)	Output Power		Antenna Gain (dBi)	Result	EIRP		Output Power	
		(dBm) ¹	mW			dBm	W	(dBm) ³	mW
14.5	2412	17.6	57.5	3.2	Pass	20.8	0.120	16.8	47.9
15.0	2442	18.2	66.1	3.2	Pass	21.4	0.138	17.3	53.7
14.0	2462	17.5	56.2	3.2	Pass	20.7	0.117	16.7	46.8

Mode: 11g

Power Setting ²	Frequency (MHz)	Output Power		Antenna Gain (dBi)	Result	EIRP		Output Power	
		(dBm) ¹	mW			dBm	W	(dBm) ³	mW
17.0	2412	17.1	51.3	3.2	Pass	20.3	0.107	14.2	26.3
21.0	2442	20.4	109.6	3.2	Pass	23.6	0.229	17.5	56.2
15.0	2462	15.5	35.5	3.2	Pass	18.7	0.074	12.8	19.1

Mode: n20

Power Setting ²	Frequency (MHz)	Output Power		Antenna Gain (dBi)	Result	EIRP		Output Power	
		(dBm) ¹	mW			dBm	W	(dBm) ³	mW
17.0	2412	17.1	51.3	3.2	Pass	20.3	0.107	14.1	25.7
22.0	2442	21.2	131.8	3.2	Pass	24.4	0.275	17.7	58.9
15.0	2462	15.5	35.5	3.2	Pass	18.7	0.074	12.6	18.2

Mode: n40

Power Setting ²	Frequency (MHz)	Output Power		Antenna Gain (dBi)	Result	EIRP		Output Power	
		(dBm) ¹	mW			dBm	W	(dBm) ³	mW
16.5	2422	15.6	36.3	3.2	Pass	18.8	0.076	13.5	22.4
21.0	2437	20.6	114.8	3.2	Pass	23.8	0.240	16.7	46.8
15.5	2452	14.9	30.9	3.2	Pass	18.1	0.065	12.8	19.1

Note 1: Output power measured using a peak power meter, spurious limit is -20dBc.

Note 2: Power setting - the software power setting used during testing, included for reference only.

Note 3: Power measured using average power meter (non-gated) and is included for reference only.



EMC Test Data

Client: Intel Corporation	Job Number: J94914
Model: 7265D2W	T-Log Number: T95471
	Project Manager: Christine Krebill
Contact: Steve Hackett	Project Coordinator: -
Standard: FCC Part 15.247, 15.407, RSS-210	Class: N/A

Run #2: Power spectral Density

Mode: 11b

Power Setting	Frequency (MHz)	PSD	Limit dBm/3kHz	Result
		(dBm/10kHz) ^{Note 1}		
14.5	2412	0.5	8.0	Pass
15.0	2442	1.1	8.0	Pass
14.0	2462	0.2	8.0	Pass

Mode: 11g

Power Setting	Frequency (MHz)	PSD	Limit dBm/3kHz	Result
		(dBm/10kHz) ^{Note 1}		
17.0	2412	-5.3	8.0	Pass
21.0	2442	-2.4	8.0	Pass
15.0	2462	-8.5	8.0	Pass

Mode: n20

Power Setting	Frequency (MHz)	PSD	Limit dBm/3kHz	Result
		(dBm/10kHz) ^{Note 1}		
17.0	2412	-5.2	8.0	Pass
23.0	2442	-1.0	8.0	Pass
15.0	2462	-8.1	8.0	Pass

Mode: n40

Power Setting	Frequency (MHz)	PSD	Limit dBm/3kHz	Result
		(dBm/10kHz) ^{Note 1}		
16.5	2422	-10.0	8.0	Pass
23.0	2437	-4.0	8.0	Pass
15.5	2452	-9.7	8.0	Pass

Note 1: Test performed per method PKSPD, in KDB 558074. Power spectral density measured using: $3\text{kHz} \leq \text{RBW} \leq 100\text{kHz}$, $\text{VBW}=3*\text{RBW}$, peak detector, span = $1.5*\text{DTS BW}$, auto sweep time, max hold.



EMC Test Data

Client: Intel Corporation	Job Number: J94914
Model: 7265D2W	T-Log Number: T95471
Contact: Steve Hackett	Project Manager: Christine Krebill
Standard: FCC Part 15.247, 15.407, RSS-210	Project Coordinator: -
	Class: N/A

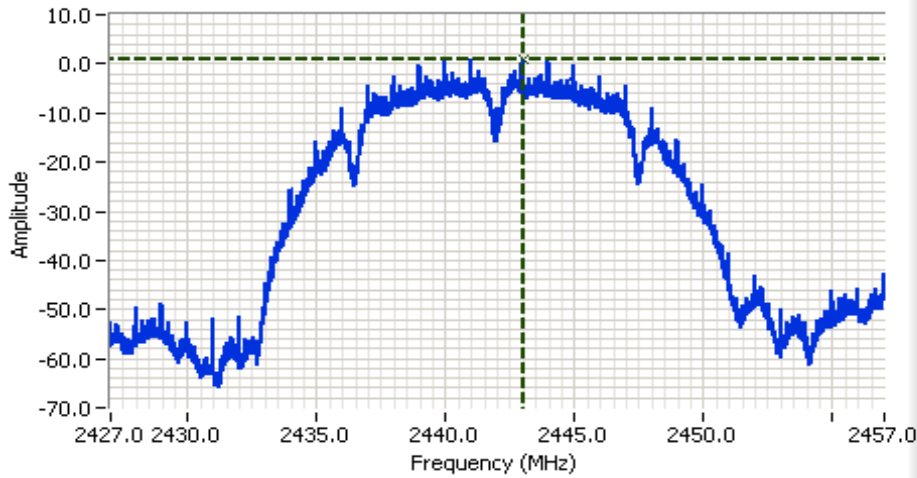

Analyzer Settings
Agilent Technologies, E4446A
CF: 2442.000 MHz
SPAN: 30.000 MHz
RB: 10.0 kHz
VB: 30.0 kHz
Detector: POS
Attn: 10 DB
RL Offset: 10.5 DB
Sweep Time: 286.9ms
Ref Lvl: 10.0 DBM

Comments
11b chain A
PSD = 1.06 dBm/10 kHz

Cursor 1 2442.9853 1.06 [icons]
0.0000 0.00 [icons]





EMC Test Data

Client: Intel Corporation	Job Number: J94914
Model: 7265D2W	T-Log Number: T95471
	Project Manager: Christine Krebill
Contact: Steve Hackett	Project Coordinator: -
Standard: FCC Part 15.247, 15.407, RSS-210	Class: N/A

Run #3: Signal Bandwidth

Mode: 11b

Power Setting	Frequency (MHz)	Bandwidth (MHz)		RBW Setting (kHz)	
		6dB	99%	6dB	99%
15.0	2442	10.043	12.43	100	300

Mode: 11g

Power Setting	Frequency (MHz)	Bandwidth (MHz)		RBW Setting (MHz)	
		6dB	99%	6dB	99%
20.5	2442	15.135	16.81	100	300

Mode: n20

Power Setting	Frequency (MHz)	Bandwidth (MHz)		RBW Setting (MHz)	
		6dB	99%	6dB	99%
21.0	2442	15.125	18.17	100	300

Mode: n40

Power Setting	Frequency (MHz)	Bandwidth (MHz)		RBW Setting (MHz)	
		6dB	99%	6dB	99%
17.5	2442	35.132	36.16	100	470

Note 1: DTS BW: RBW=100kHz, VBW ≥ 3*RBW, peak detector, max hold, auto sweep time.
 99% BW: RBW=1.5% of of 99%BW, VBW ≥ 3*RBW, peak detector, max hold, auto sweep time.



EMC Test Data

Client: Intel Corporation	Job Number: J94914
Model: 7265D2W	T-Log Number: T95471
	Project Manager: Christine Krebill
Contact: Steve Hackett	Project Coordinator: -
Standard: FCC Part 15.247, 15.407, RSS-210	Class: N/A

Run #4a: Out of Band Spurious Emissions

Date of Test: 6/17/2014

Test Engineer: Jack Liu

Test Location: FT Lab# 4A

Mode: 802.11b

Config. Used: 1

Config Change: None

EUT Voltage: 3.3Vdc

Frequency (MHz)	Power Setting	Mode	Limit	Result
2412	14.5	b	-30dBc	Pass
2442	15.0	b	-30dBc	Pass
2462	14.0	b	-30dBc	Pass

Plots for low channel

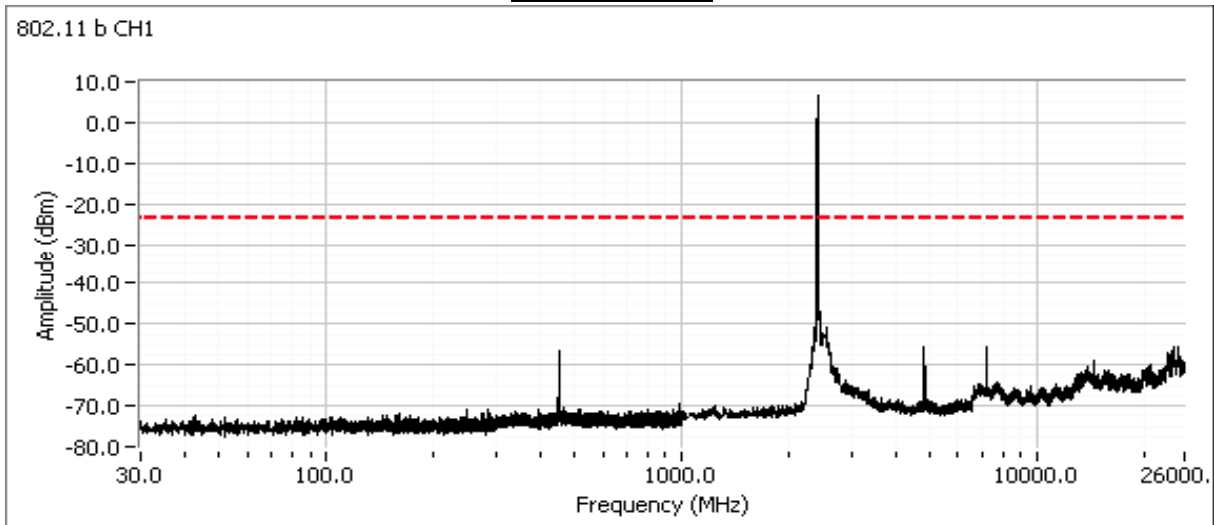

Client: Intel Corporation	Job Number: J94914
Model: 7265D2W	T-Log Number: T95471
	Project Manager: Christine Krebill
Contact: Steve Hackett	Project Coordinator: -
Standard: FCC Part 15.247, 15.407, RSS-210	Class: N/A

Additional plot showing compliance with -30dBc limit from 2390 MHz to 2400 MHz. Radiated measurements used to show compliance with the limits in the restricted band below 2390 MHz.

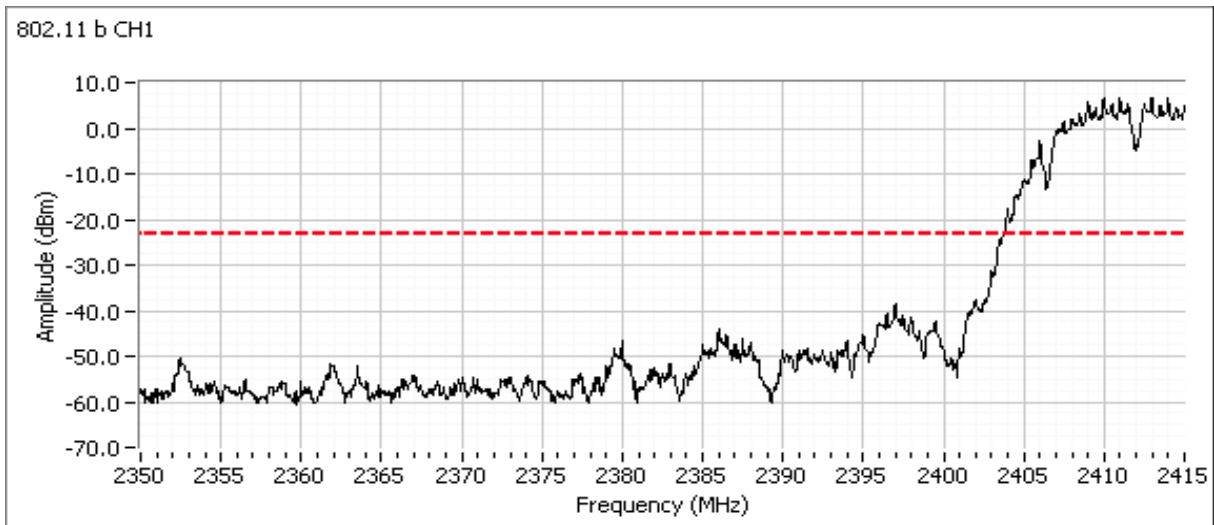

Plots for center channel

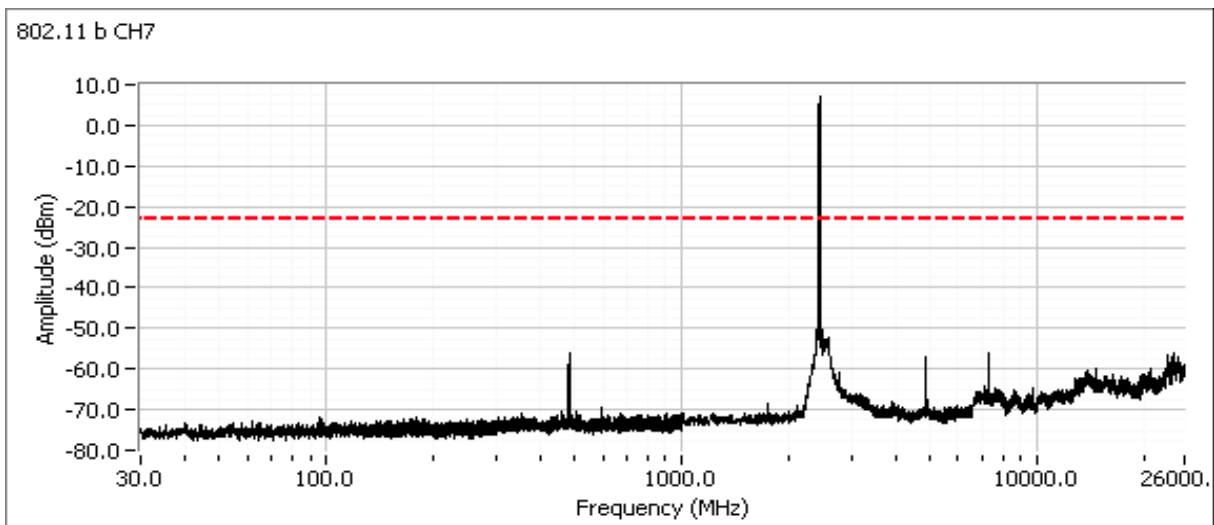

Client:	Intel Corporation	Job Number:	J94914
Model:	7265D2W	T-Log Number:	T95471
Contact:	Steve Hackett	Project Manager:	Christine Krebill
Standard:	FCC Part 15.247, 15.407, RSS-210	Project Coordinator:	-
		Class:	N/A

Plots for high channel

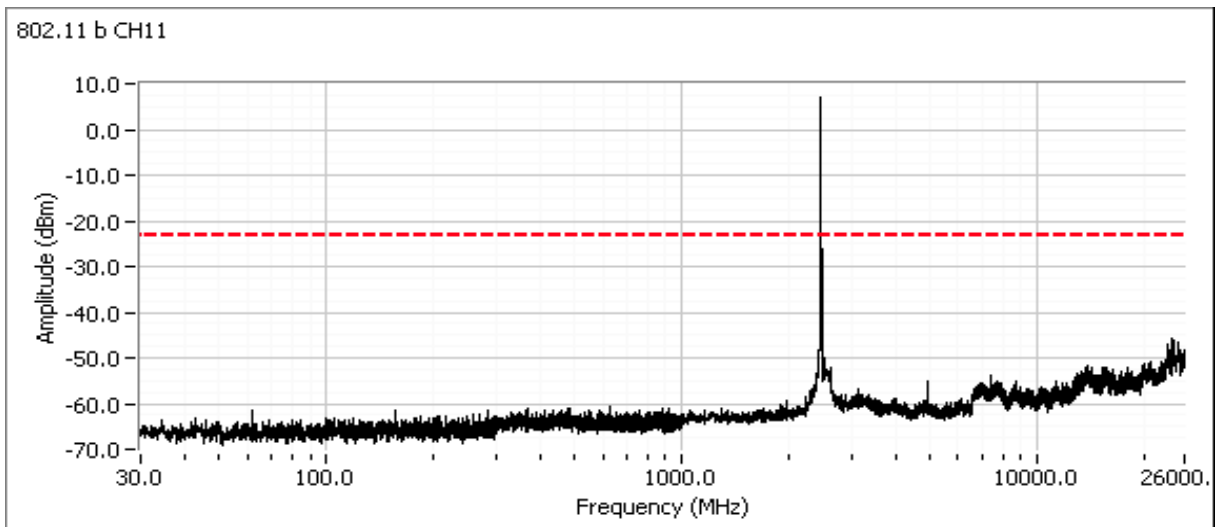



EMC Test Data

Client: Intel Corporation	Job Number: J94914
Model: 7265D2W	T-Log Number: T95471
	Project Manager: Christine Krebill
Contact: Steve Hackett	Project Coordinator: -
Standard: FCC Part 15.247, 15.407, RSS-210	Class: N/A

Run #4b: Out of Band Spurious Emissions

Date of Test: 6/17/2014

Test Engineer: Jack Liu, M. Birgani

Test Location: FT Lab# 4A

Config. Used: 1

Config Change: None

EUT Voltage: 3.3Vdc

Mode: 802.11g

Frequency (MHz)	Power Setting	Mode	Limit	Result
2412	17.0	g	-20dBc	Pass
2442	21.0	g	-20dBc	Pass
2462	15.0	g	-20dBc	Pass

Plots for low channel

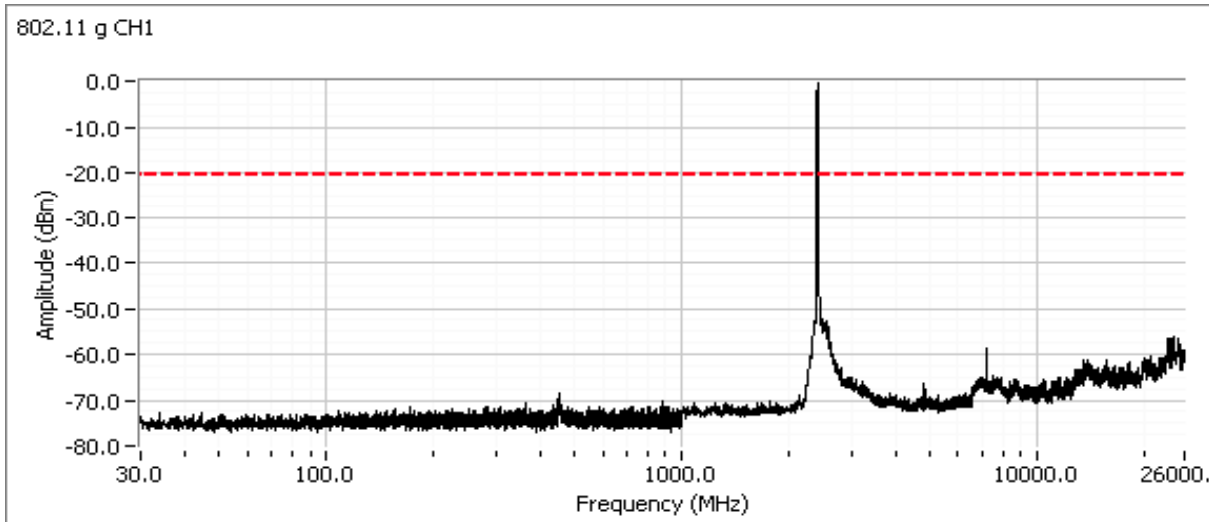

Client: Intel Corporation	Job Number: J94914
Model: 7265D2W	T-Log Number: T95471
	Project Manager: Christine Krebill
Contact: Steve Hackett	Project Coordinator: -
Standard: FCC Part 15.247, 15.407, RSS-210	Class: N/A

Additional plot showing compliance with -20dBc limit from 2390 MHz to 2400 MHz. Radiated measurements used to show compliance with the limits in the restricted band below 2390 MHz.

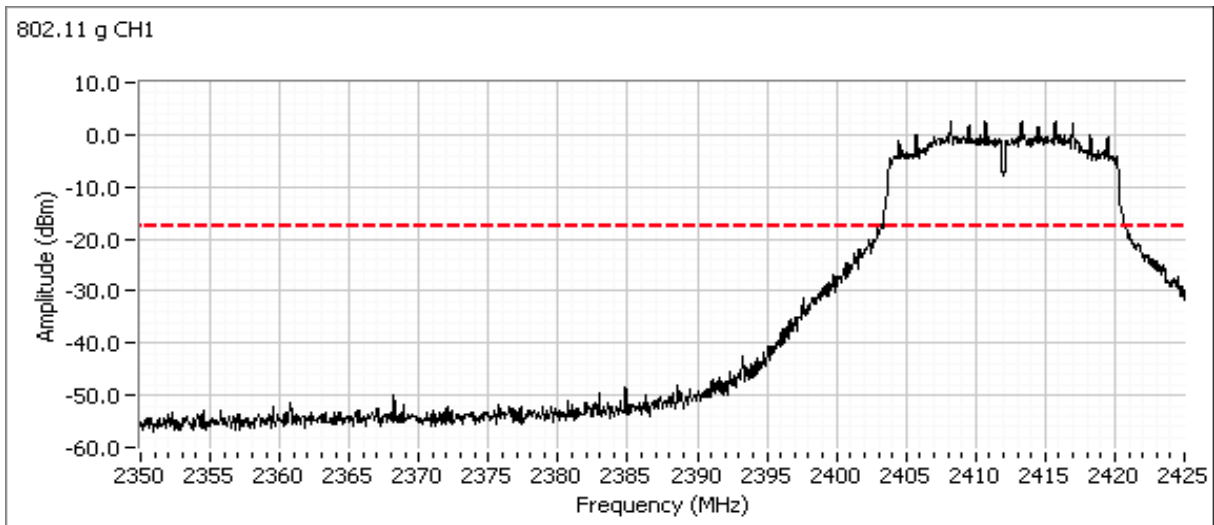

Plots for center channel

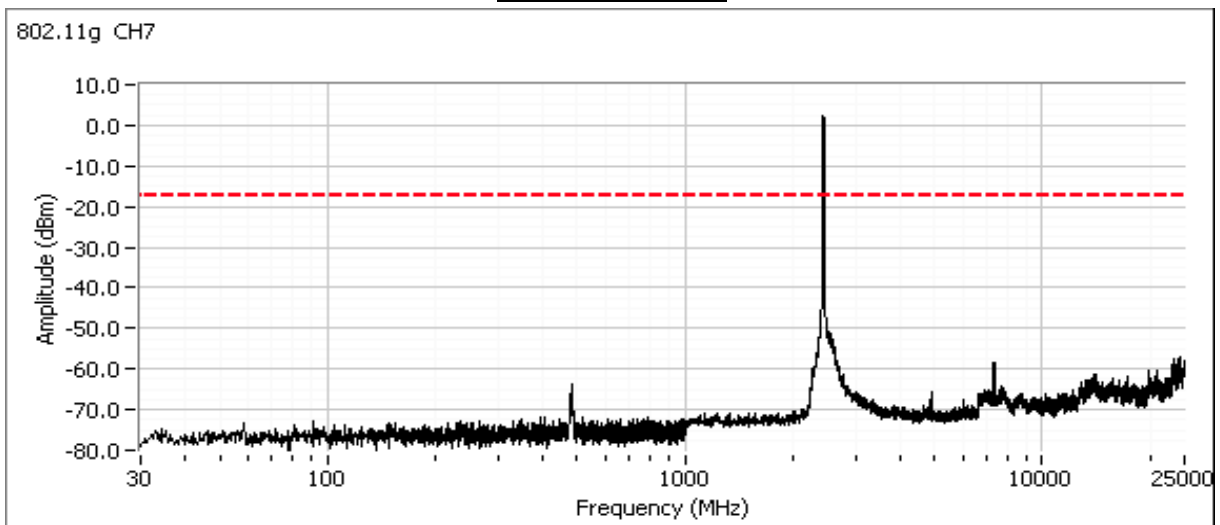

Client:	Intel Corporation	Job Number:	J94914
Model:	7265D2W	T-Log Number:	T95471
Contact:	Steve Hackett	Project Manager:	Christine Krebill
Standard:	FCC Part 15.247, 15.407, RSS-210	Project Coordinator:	-
		Class:	N/A

Plots for high channel

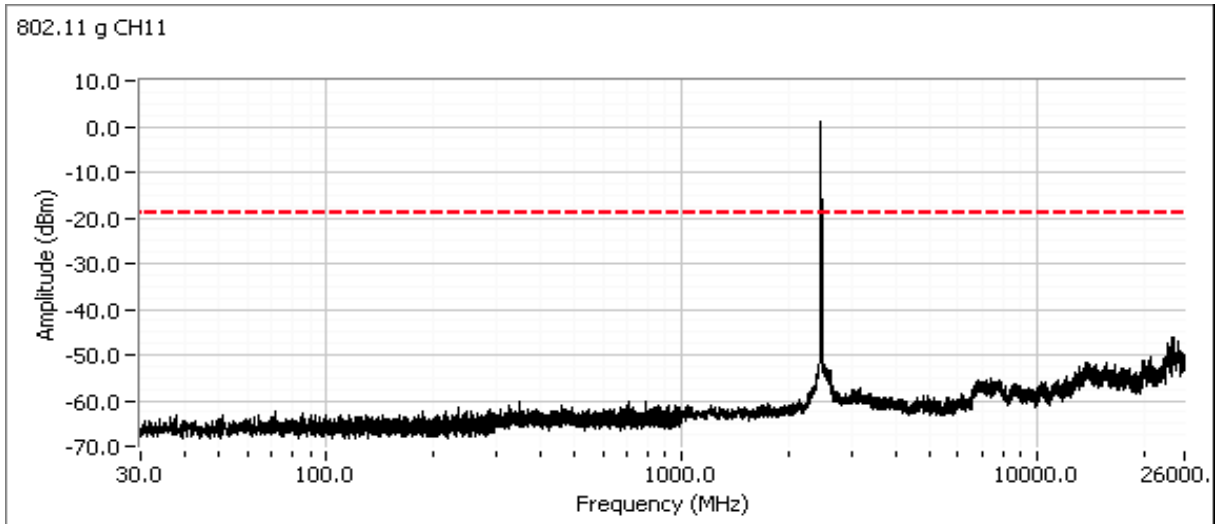



EMC Test Data

Client: Intel Corporation	Job Number: J94914
Model: 7265D2W	T-Log Number: T95471
	Project Manager: Christine Krebill
Contact: Steve Hackett	Project Coordinator: -
Standard: FCC Part 15.247, 15.407, RSS-210	Class: N/A

Run #4c: Out of Band Spurious Emissions

Date of Test: 6/17/2014

Test Engineer: M. Birgani

Test Location: FT Lab# 4A

Config. Used: 1

Config Change: None

EUT Voltage: 3.3Vdc

Mode: 802.11n20

Frequency (MHz)	Power Setting	Mode	Limit	Result
2412	17.0	n20	-20dBc	Pass
2442	23.0	n20	-20dBc	Pass
2462	15.0	n20	-20dBc	Pass

Plots for low channel

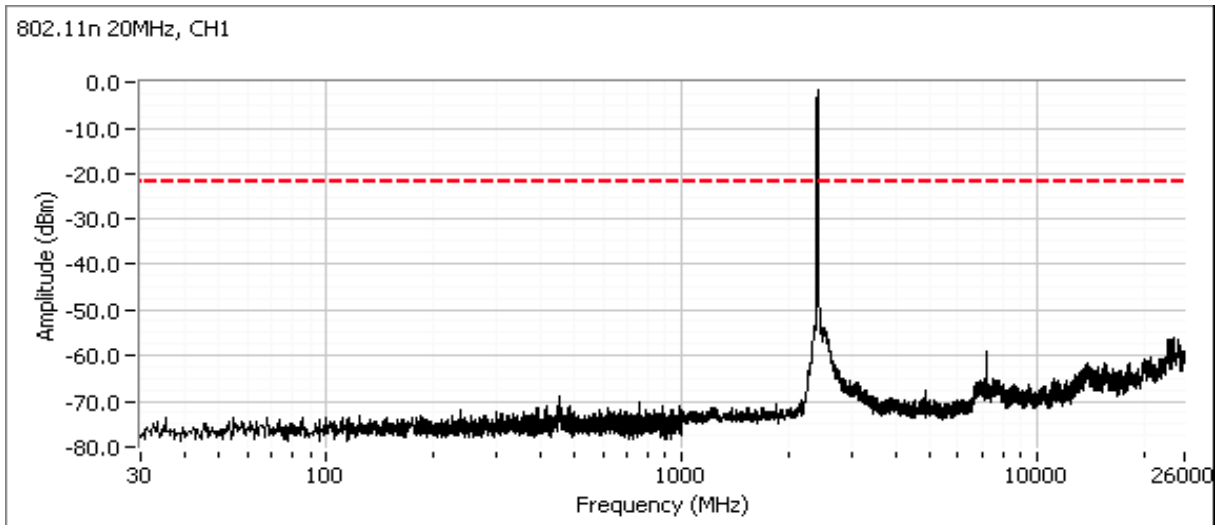

Client: Intel Corporation	Job Number: J94914
Model: 7265D2W	T-Log Number: T95471
	Project Manager: Christine Krebill
Contact: Steve Hackett	Project Coordinator: -
Standard: FCC Part 15.247, 15.407, RSS-210	Class: N/A

Additional plot showing compliance with -20dBc limit from 2390 MHz to 2400 MHz. Radiated measurements used to show compliance with the limits in the restricted band below 2390 MHz.

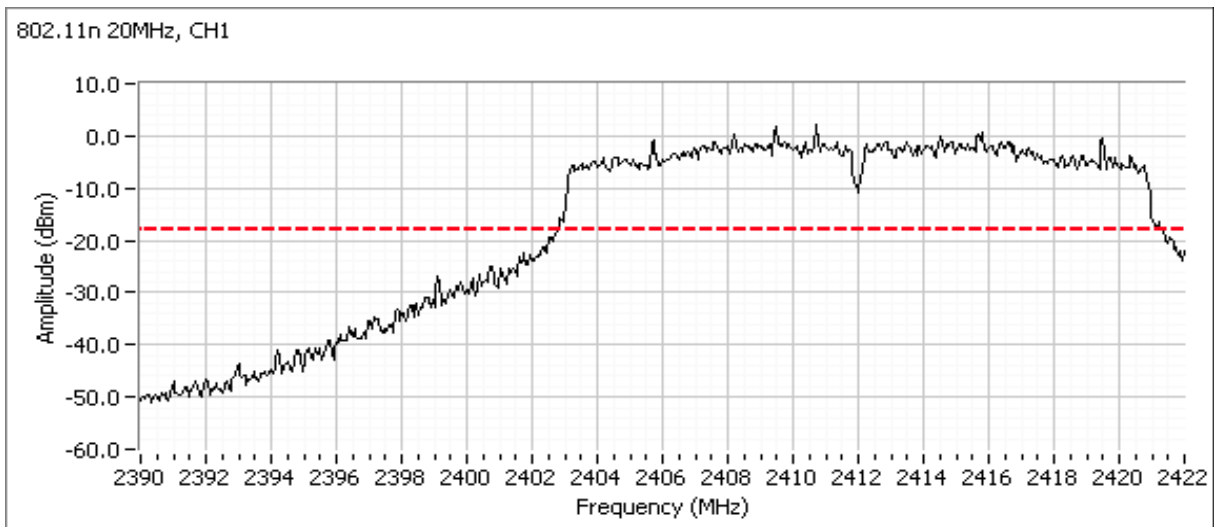

Plots for center channel

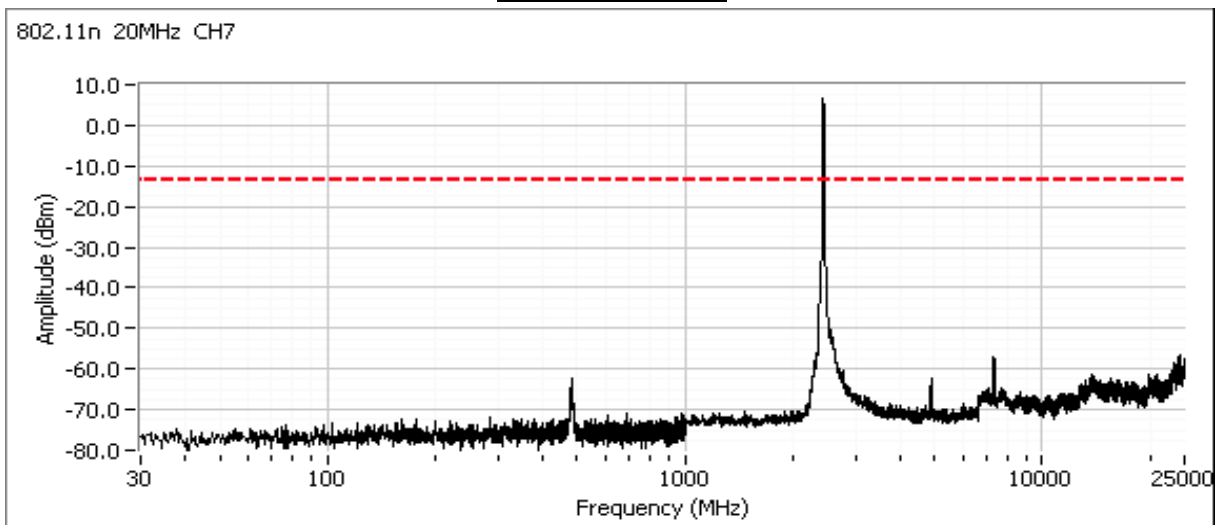

Client:	Intel Corporation	Job Number:	J94914
Model:	7265D2W	T-Log Number:	T95471
Contact:	Steve Hackett	Project Manager:	Christine Krebill
Standard:	FCC Part 15.247, 15.407, RSS-210	Project Coordinator:	-
		Class:	N/A

Plots for high channel

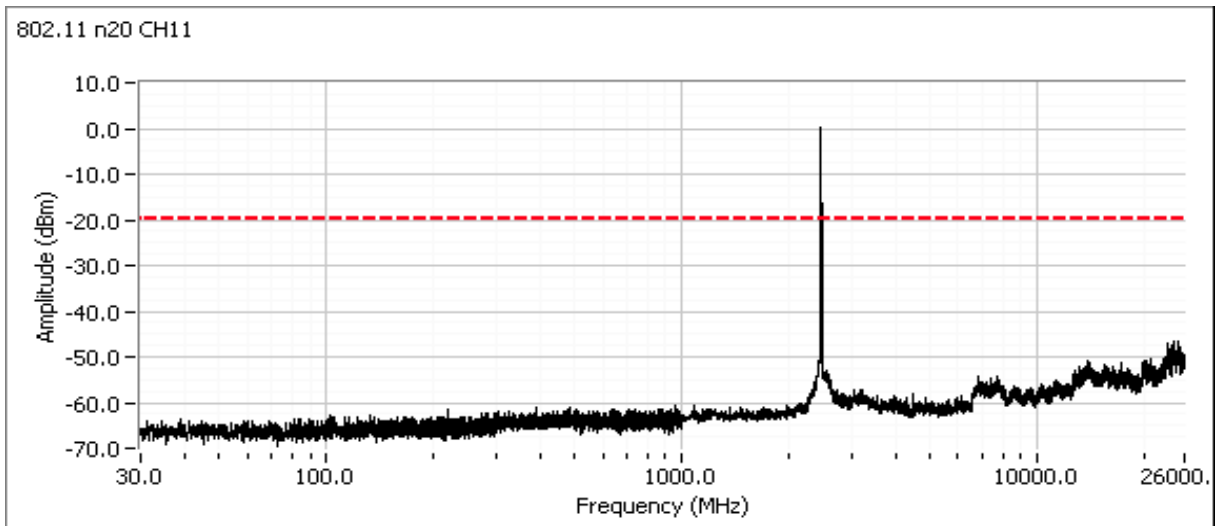



EMC Test Data

Client: Intel Corporation	Job Number: J94914
Model: 7265D2W	T-Log Number: T95471
Contact: Steve Hackett	Project Manager: Christine Krebill
Standard: FCC Part 15.247, 15.407, RSS-210	Project Coordinator: -
	Class: N/A

Run #4d: Out of Band Spurious Emissions

Date of Test: 6/17/2014

Test Engineer: M. Birgani

Test Location: FT Lab# 4A

Config. Used: 1

Config Change: None

EUT Voltage: 3.3Vdc

Mode: 802.11n40

Frequency (MHz)	Power Setting	Mode	Limit	Result
2422	16.5	n40	-20dBc	Pass
2437	23.0	n40	-20dBc	Pass
2452	15.5	n40	-20dBc	Pass

Plots for low channel

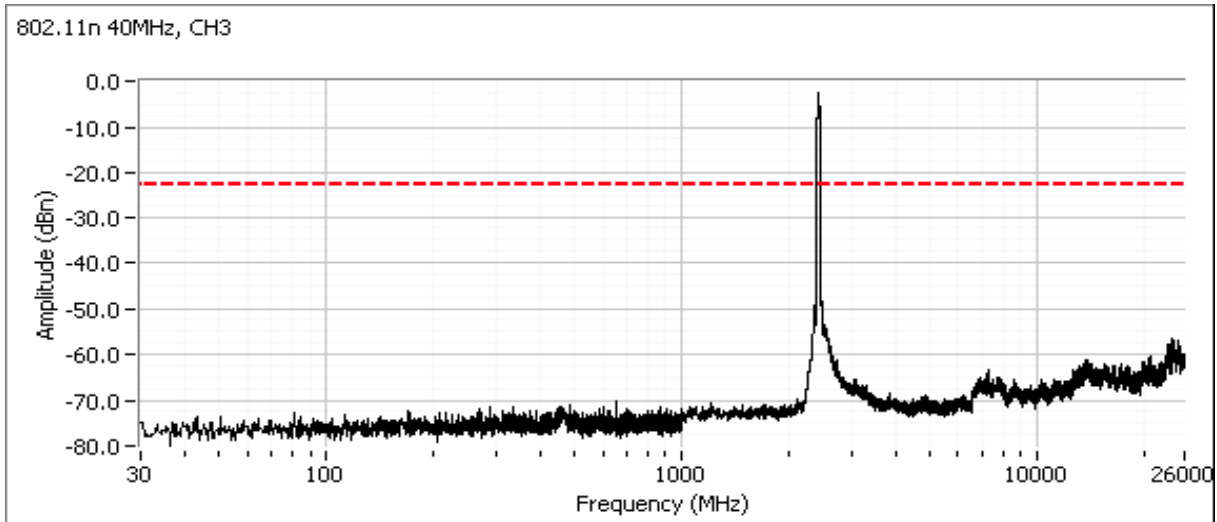

Client: Intel Corporation	Job Number: J94914
Model: 7265D2W	T-Log Number: T95471
	Project Manager: Christine Krebill
Contact: Steve Hackett	Project Coordinator: -
Standard: FCC Part 15.247, 15.407, RSS-210	Class: N/A

Additional plot showing compliance with -30dBc limit from 2390 MHz to 2400 MHz. Radiated measurements used to show compliance with the limits in the restricted band below 2390 MHz.

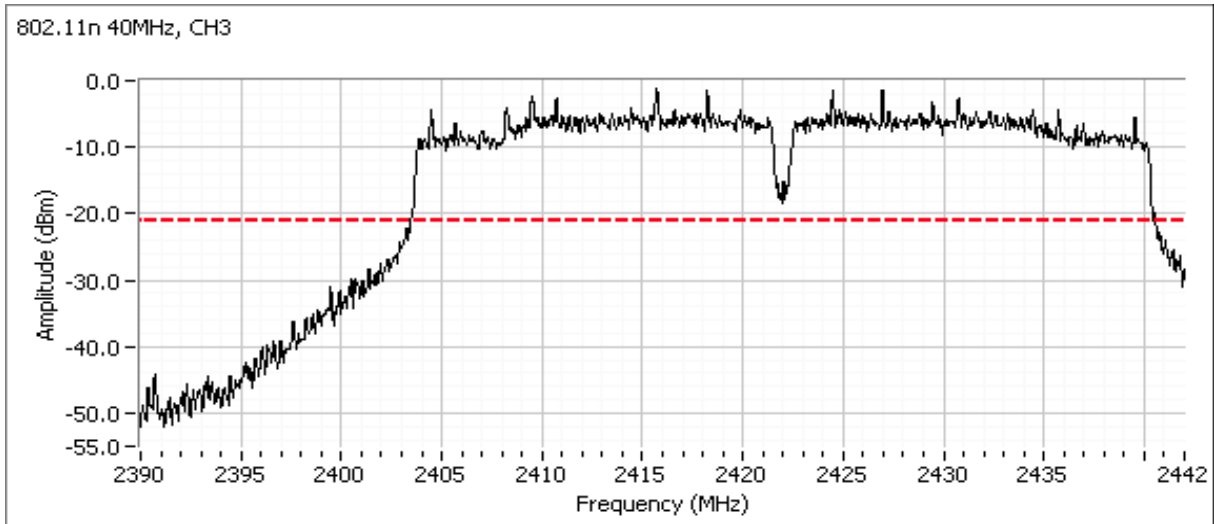

Plots for center channel

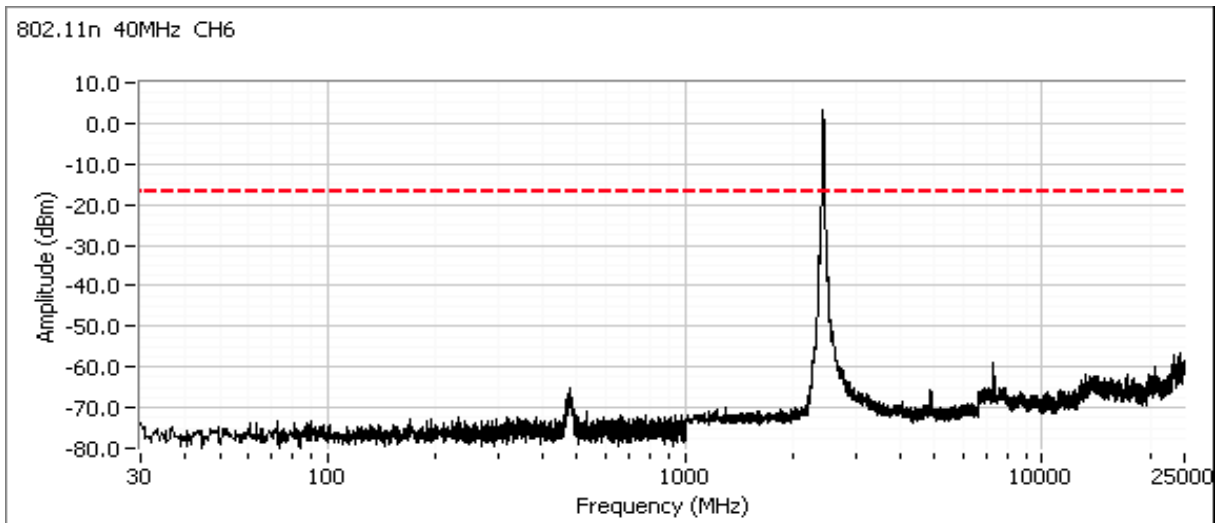

Client:	Intel Corporation	Job Number:	J94914
Model:	7265D2W	T-Log Number:	T95471
Contact:	Steve Hackett	Project Manager:	Christine Krebill
Standard:	FCC Part 15.247, 15.407, RSS-210	Project Coordinator:	-
		Class:	N/A

Plots for high channel

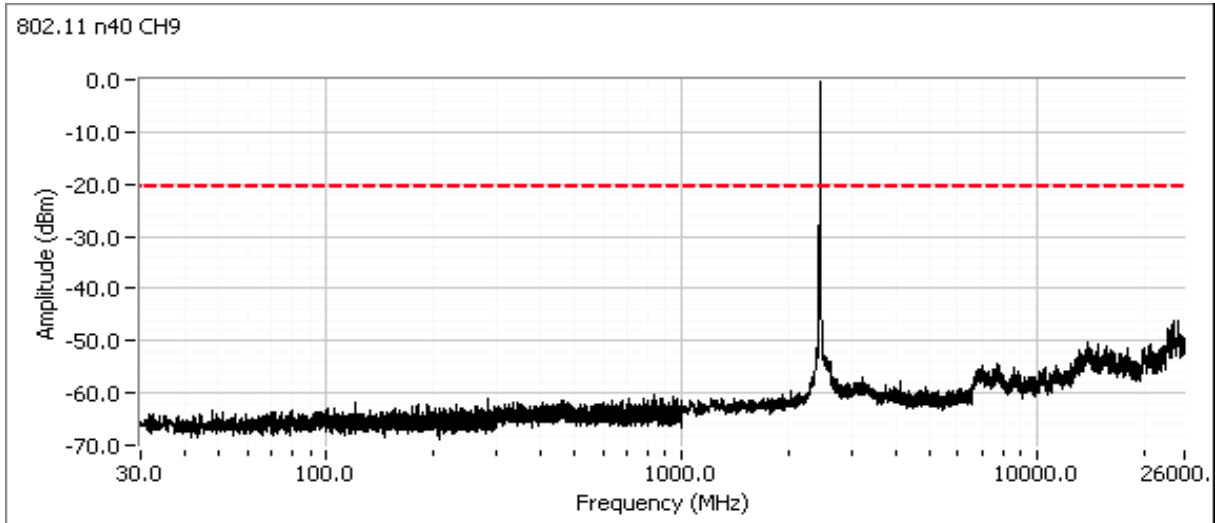



EMC Test Data

Client:	Intel Corporation	Job Number:	J94914
Model:	7265D2W	T-Log Number:	T95471
Contact:	Steve Hackett	Project Manager:	Christine Krebill
Standard:	FCC Part 15.247, 15.407, RSS-210	Project Coordinator:	-
		Class:	N/A

RSS 210 and FCC 15.247 (DTS) Antenna Port Measurements Power, PSD, Bandwidth and Spurious Emissions

Test Specific Details

Objective: The objective of this test session is to perform final qualification testing of the EUT with respect to the specification listed above.

Date of Test: 6/18/2014
 Test Engineer: John Caizzi / Jack Liu
 Test Location: Lab 4A

Config. Used: 1
 Config Change: none
 EUT Voltage: 3.3Vdc

General Test Configuration

The EUT was connected to the spectrum analyzer or power meter via a suitable attenuator. All measurements were made on a single chain.

All measurements have been corrected to allow for the external attenuators used.

Ambient Conditions:

Temperature: 24 °C
 Rel. Humidity: 38 %

Summary of Results

Run #	Pwr setting	Avg Pwr	Test Performed	Limit	Pass / Fail	Result / Margin
1			Output Power	15.247(b)	Pass	b mode: 18.3 dBm g mode: 20.2 dBm n20 mode: 20.8 dBm n40 mode: 19.7 dBm
2			Power spectral Density (PSD)	15.247(d)	Pass	1.3 dBm/10kHz
3			Minimum 6dB Bandwidth	15.247(a)	Pass	10.043 MHz
3			99% Bandwidth	RSS GEN	-	36.33 MHz
4			Spurious emissions	15.247(b)	Pass	All emissions < -20 dBc

Modifications Made During Testing

No modifications were made to the EUT during testing

Deviations From The Standard

No deviations were made from the requirements of the standard.



EMC Test Data

Client:	Intel Corporation	Job Number:	J94914
Model:	7265D2W	T-Log Number:	T95471
		Project Manager:	Christine Krebill
Contact:	Steve Hackett	Project Coordinator:	-
Standard:	FCC Part 15.247, 15.407, RSS-210	Class:	N/A

Procedure Comments:

Measurements performed in accordance with FCC KDB 558074

Mode	Data Rate	Duty Cycle (x)	Constant DC?	T (ms)	Pwr Cor Factor*	Lin Volt Cor Factor**	Min VBW for FS (Hz)
11b	1	0.99	Yes	2.272	0.0	0.0	440
11g	6	0.99	Yes	2.06	0.0	0.0	485
n20	HT0	0.99	Yes	1.919	0.0	0.0	521
n40	HT0	0.97	Yes	0.944	0.1	0.2	1059

Sample Notes

MAC Address: 001500F15B5D DRTU Tool Version 1.7.3-935 Driver version 17.1.0.11



EMC Test Data

Client:	Intel Corporation	Job Number:	J94914
Model:	7265D2W	T-Log Number:	T95471
Contact:	Steve Hackett	Project Manager:	Christine Krebill
Standard:	FCC Part 15.247, 15.407, RSS-210	Project Coordinator:	-
		Class:	N/A

Run #1: Output Power

Mode: 11b

Power Setting ²	Frequency (MHz)	Output Power		Antenna Gain (dBi)	Result	EIRP		Output Power	
		(dBm) ¹	mW			dBm	W	(dBm) ³	mW
21.5	2412	18.3	67.6	3.2	Pass	21.5	0.141	16.6	45.7
22.0	2442	18.2	66.1	3.2	Pass	21.4	0.138	17.7	58.9
21.0	2462	17.8	60.3	3.2	Pass	21.0	0.126	16.6	45.7

Mode: 11g

Power Setting ²	Frequency (MHz)	Output Power		Antenna Gain (dBi)	Result	EIRP		Output Power	
		(dBm) ¹	mW			dBm	W	(dBm) ³	mW
24.0	2412	18.2	66.1	3.2	Pass	21.4	0.138	14.6	28.8
27.0	2442	20.2	104.7	3.2	Pass	23.4	0.219	17.3	53.7
21.5	2462	15.5	35.5	3.2	Pass	18.7	0.074	12.4	17.4

Mode: n20

Power Setting ²	Frequency (MHz)	Output Power		Antenna Gain (dBi)	Result	EIRP		Output Power	
		(dBm) ¹	mW			dBm	W	(dBm) ³	mW
24.0	2412	18.3	67.6	3.2	Pass	21.5	0.141	14.8	30.2
29.0	2442	20.8	120.2	3.2	Pass	24.0	0.251	17.4	55.0
22.0	2462	16.1	40.7	3.2	Pass	19.3	0.085	12.8	19.1

Mode: n40

Power Setting ²	Frequency (MHz)	Output Power		Antenna Gain (dBi)	Result	EIRP		Output Power	
		(dBm) ¹	mW			dBm	W	(dBm) ³	mW
21.5	2422	14.7	29.5	3.2	Pass	17.9	0.062	13.5	22.4
25.0	2442	19.5	89.1	3.2	Pass	22.7	0.186	15.2	33.1
20.5	2452	14.1	25.7	3.2	Pass	17.3	0.054	11.4	13.8

- Note 1: Output power measured using a peak power meter, spurious limit is -20dBc.
 Note 2: Power setting - the software power setting used during testing, included for reference only.
 Note 3: Power measured using average power meter (non-gated) and is included for reference only.



EMC Test Data

Client: Intel Corporation	Job Number: J94914
Model: 7265D2W	T-Log Number: T95471
	Project Manager: Christine Krebill
Contact: Steve Hackett	Project Coordinator: -
Standard: FCC Part 15.247, 15.407, RSS-210	Class: N/A

Run #2: Power spectral Density

Mode: 11b

Power Setting	Frequency (MHz)	PSD	Limit dBm/3kHz	Result
		(dBm/10kHz) ^{Note 1}		
21.5	2412	1.3	8.0	Pass
22.0	2442	1.2	8.0	Pass
21.0	2462	0.5	8.0	Pass

Mode: 11g

Power Setting	Frequency (MHz)	PSD	Limit dBm/3kHz	Result
		(dBm/10kHz) ^{Note 1}		
24.0	2412	-4.4	8.0	Pass
27.0	2442	-3.2	8.0	Pass
21.5	2462	-7.1	8.0	Pass

Mode: n20

Power Setting	Frequency (MHz)	PSD	Limit dBm/3kHz	Result
		(dBm/10kHz) ^{Note 1}		
24.0	2412	-5.1	8.0	Pass
29.0	2442	-1.7	8.0	Pass
22.0	2462	-7.7	8.0	Pass

Mode: n40

Power Setting	Frequency (MHz)	PSD	Limit dBm/3kHz	Result
		(dBm/10kHz) ^{Note 1}		
21.5	2422	-9.3	8.0	Pass
28.0	2442	-5.6	8.0	Pass
20.5	2452	-11.3	8.0	Pass

Note 1: Test performed per method PKSPD, in KDB 558074. Power spectral density measured using: $3\text{kHz} \leq \text{RBW} \leq 100\text{kHz}$, $\text{VBW}=3*\text{RBW}$, peak detector, span = $1.5*\text{DTS BW}$, auto sweep time, max hold.

Client: Intel Corporation	Job Number: J94914
Model: 7265D2W	T-Log Number: T95471
Contact: Steve Hackett	Project Manager: Christine Krebill
Standard: FCC Part 15.247, 15.407, RSS-210	Project Coordinator: -
	Class: N/A

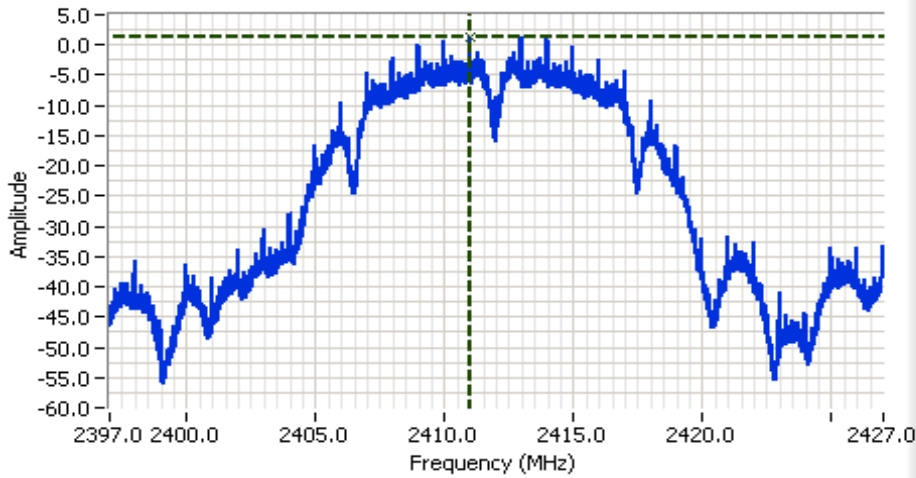

Analyzer Settings

- Agilent Technologies, E4446A
- CF: 2412.000 MHz
- SPAN: 30.000 MHz
- RB: 10.0 kHz
- VB: 30.0 kHz
- Detector: POS
- Attn: 10 DB
- RL Offset: 10.5 DB
- Sweep Time: 286.9ms
- Ref Lvl: 10.0 DBM

Comments

- 11b chain B
- PSD = 1.30 dBm/10kHz

Cursor 1 2410.9847 1.30

0.0000 0.00



EMC Test Data

Client: Intel Corporation	Job Number: J94914
Model: 7265D2W	T-Log Number: T95471
	Project Manager: Christine Krebill
Contact: Steve Hackett	Project Coordinator: -
Standard: FCC Part 15.247, 15.407, RSS-210	Class: N/A

Run #3: Signal Bandwidth

Mode: 11b

Power Setting	Frequency (MHz)	Bandwidth (MHz)		RBW Setting (kHz)	
		6dB	99%	6dB	99%
22.0	2442	10.043	12.47	100	300

Mode: 11g

Power Setting	Frequency (MHz)	Bandwidth (MHz)		RBW Setting (MHz)	
		6dB	99%	6dB	99%
27.0	2442	15.125	16.92	100	300

Mode: n20

Power Setting	Frequency (MHz)	Bandwidth (MHz)		RBW Setting (MHz)	
		6dB	99%	6dB	99%
29.0	2442	15.125	19.15	100	300

Mode: n40

Power Setting	Frequency (MHz)	Bandwidth (MHz)		RBW Setting (MHz)	
		6dB	99%	6dB	99%
28.0	2442	35.078	36.33	100	510

Note 1: DTS BW: RBW=100kHz, VBW ≥ 3*RBW, peak detector, max hold, auto sweep time.
 99% BW: RBW=1-5% of of 99%BW, VBW ≥ 3*RBW, peak detector, max hold, auto sweep time.

Client: Intel Corporation	Job Number: J94914
Model: 7265D2W	T-Log Number: T95471
	Project Manager: Christine Krebill
Contact: Steve Hackett	Project Coordinator: -
Standard: FCC Part 15.247, 15.407, RSS-210	Class: N/A

Run #4a: Out of Band Spurious Emissions

Mode: 802.11b

Frequency (MHz)	Power Setting	Mode	Limit	Result
2412	21.5	b	-20dBc	Pass
2442	22.0	b	-20dBc	Pass
2462	21.0	b	-20dBc	Pass

Plots for low channel

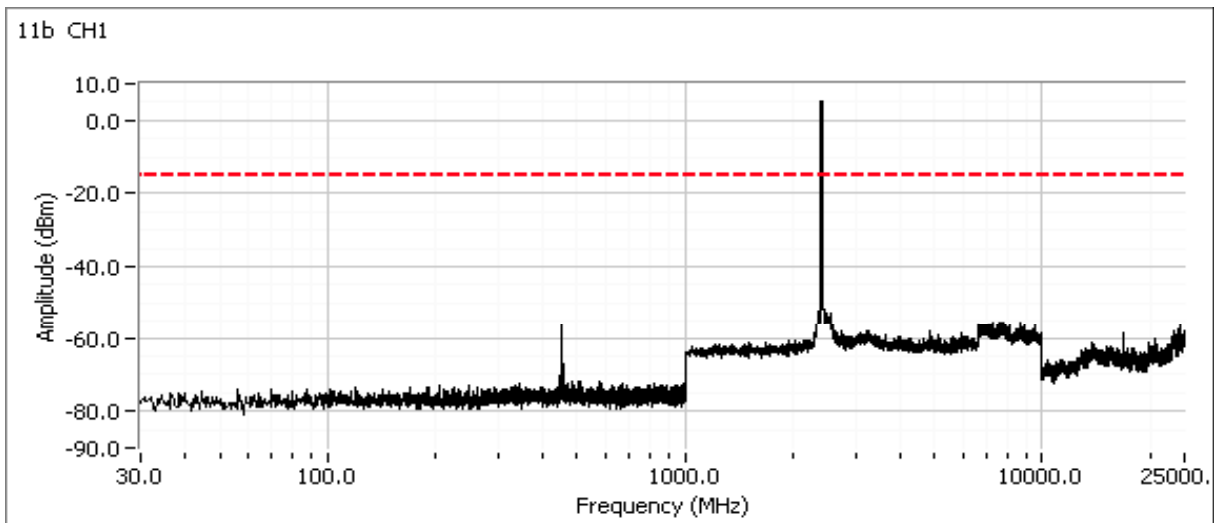

Client: Intel Corporation	Job Number: J94914
Model: 7265D2W	T-Log Number: T95471
	Project Manager: Christine Krebill
Contact: Steve Hackett	Project Coordinator: -
Standard: FCC Part 15.247, 15.407, RSS-210	Class: N/A

Additional plot showing compliance with -20dBc limit from 2390 MHz to 2400 MHz. Radiated measurements used to show compliance with the limits in the restricted band below 2390 MHz.

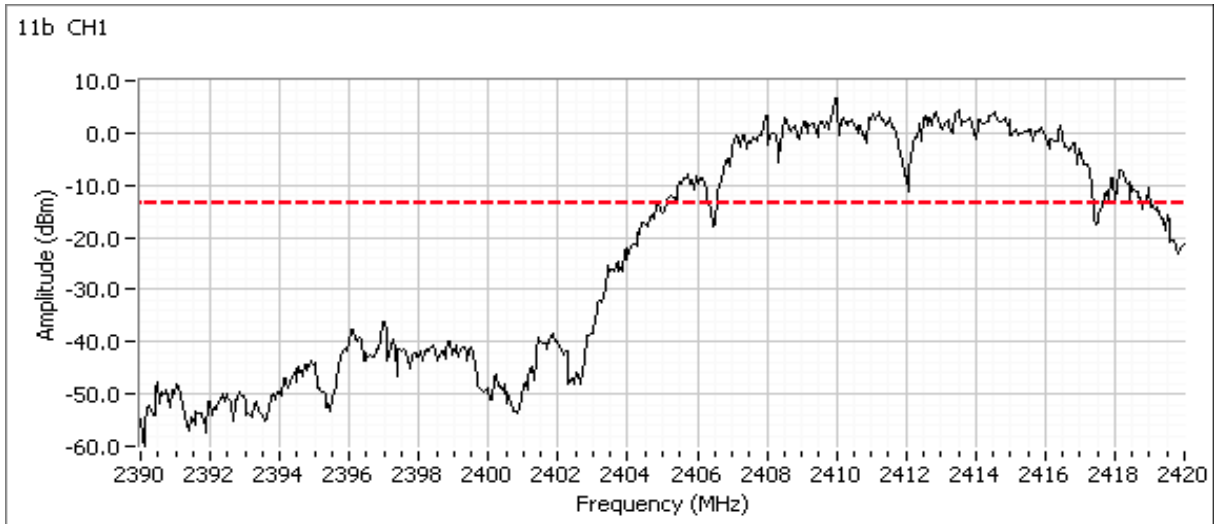

Plot for center channel

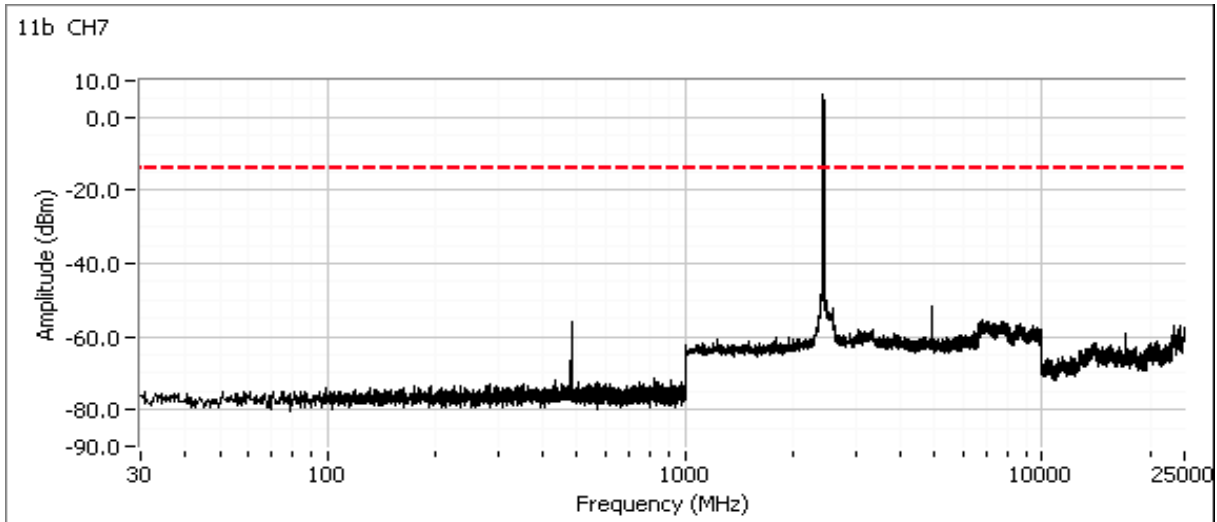

Client: Intel Corporation	Job Number: J94914
Model: 7265D2W	T-Log Number: T95471
	Project Manager: Christine Krebill
Contact: Steve Hackett	Project Coordinator: -
Standard: FCC Part 15.247, 15.407, RSS-210	Class: N/A

Plot for high channel

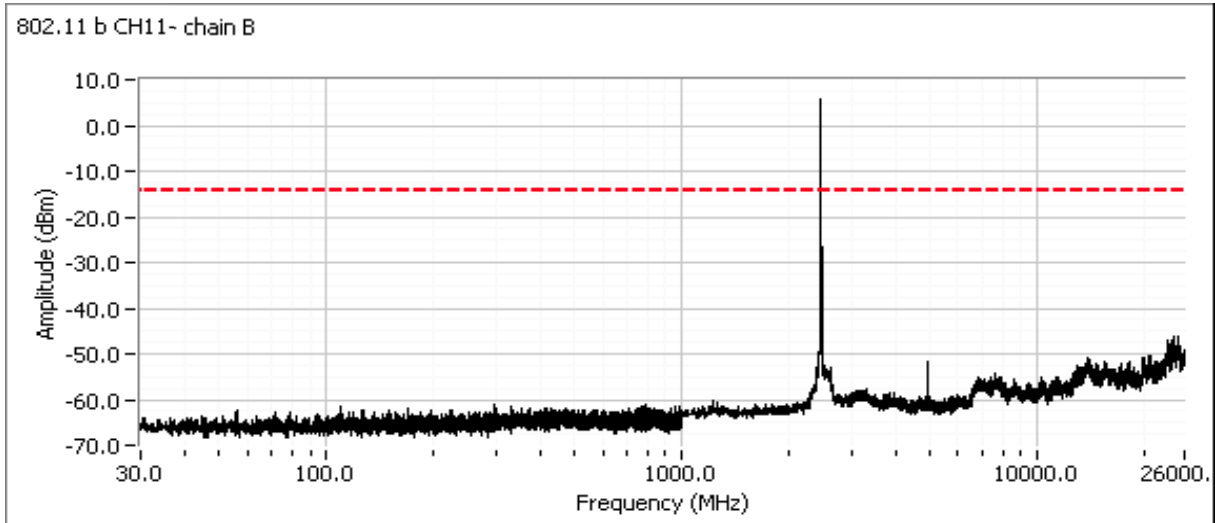

Client: Intel Corporation	Job Number: J94914
Model: 7265D2W	T-Log Number: T95471
	Project Manager: Christine Krebill
Contact: Steve Hackett	Project Coordinator: -
Standard: FCC Part 15.247, 15.407, RSS-210	Class: N/A

Run #4b: Out of Band Spurious Emissions

Mode: 802.11g

Frequency (MHz)	Power Setting	Mode	Limit	Result
2412	27.0	g	-20dBc	Pass
2442	27.0	g	-20dBc	Pass
2462	21.5	g	-20dBc	Pass

Plots for low channel

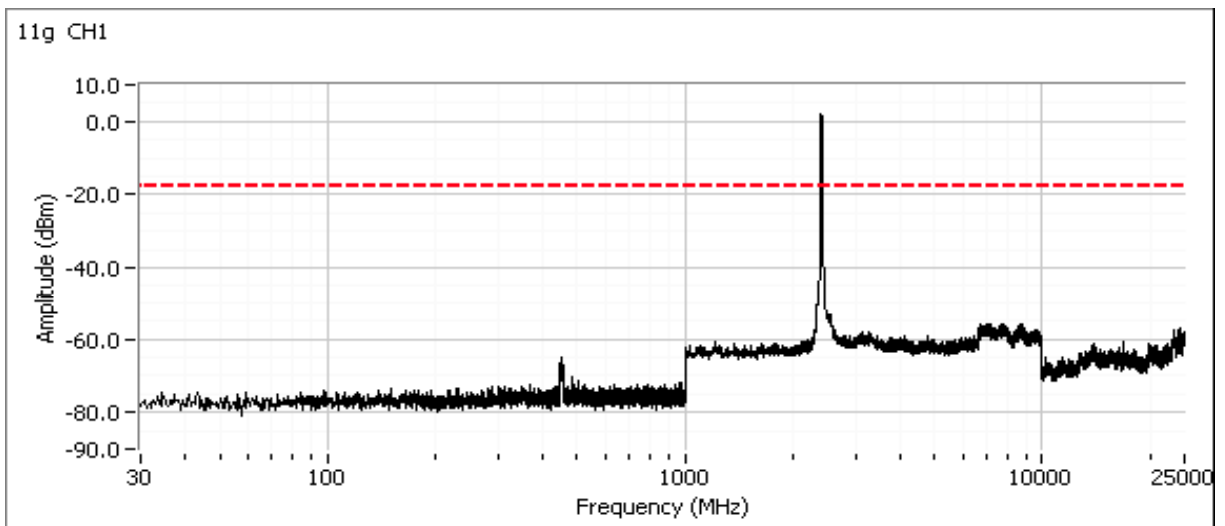

Client: Intel Corporation	Job Number: J94914
Model: 7265D2W	T-Log Number: T95471
	Project Manager: Christine Krebill
Contact: Steve Hackett	Project Coordinator: -
Standard: FCC Part 15.247, 15.407, RSS-210	Class: N/A

Additional plot showing compliance with -20dBc limit from 2390 MHz to 2400 MHz. Radiated measurements used to show compliance with the limits in the restricted band below 2390 MHz.

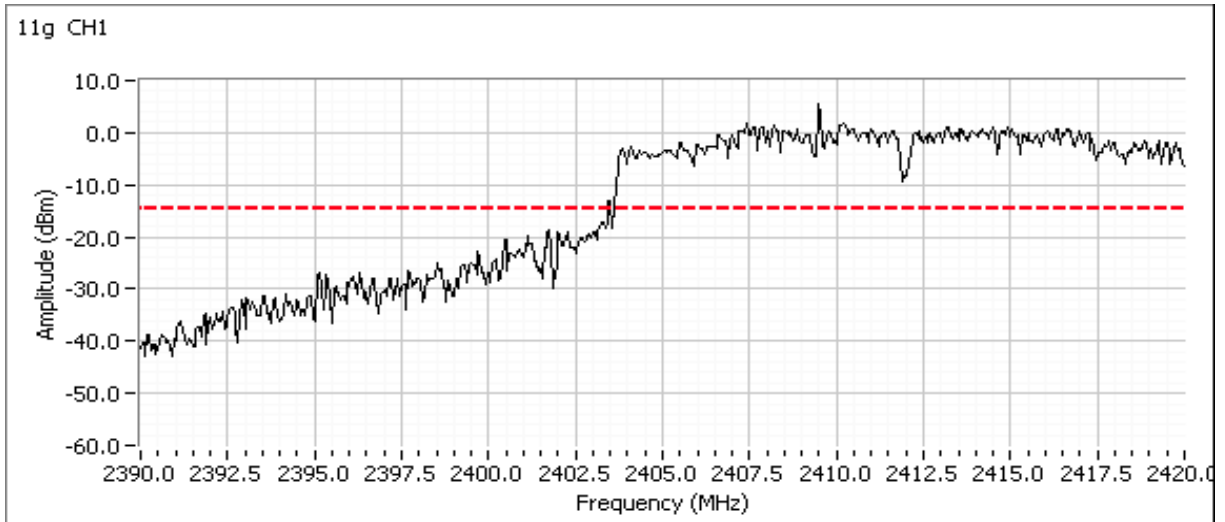

Plots for center channel

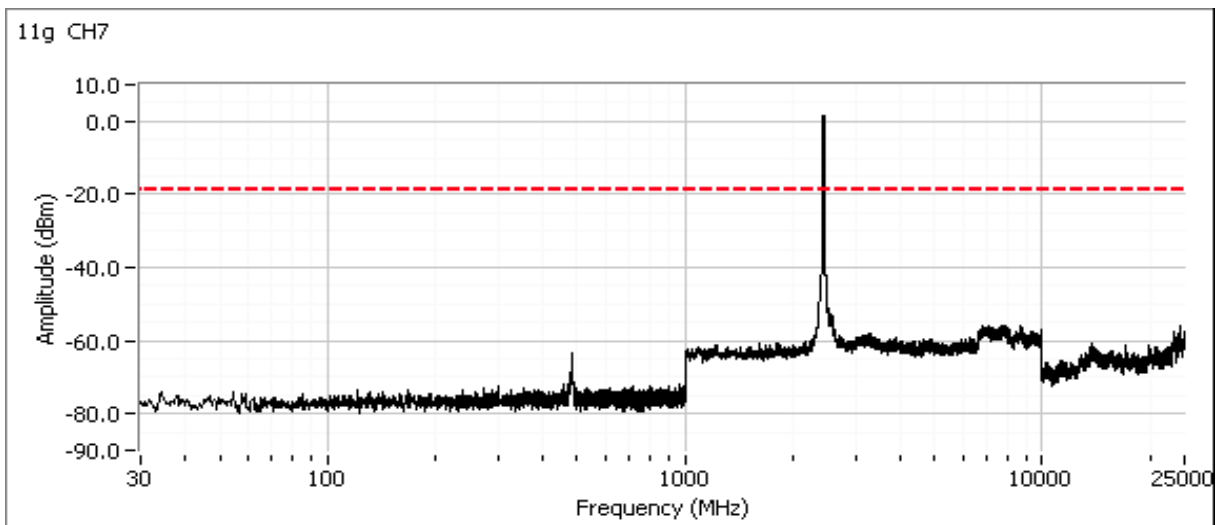

Client: Intel Corporation	Job Number: J94914
Model: 7265D2W	T-Log Number: T95471
	Project Manager: Christine Krebill
Contact: Steve Hackett	Project Coordinator: -
Standard: FCC Part 15.247, 15.407, RSS-210	Class: N/A

Plots for high channel

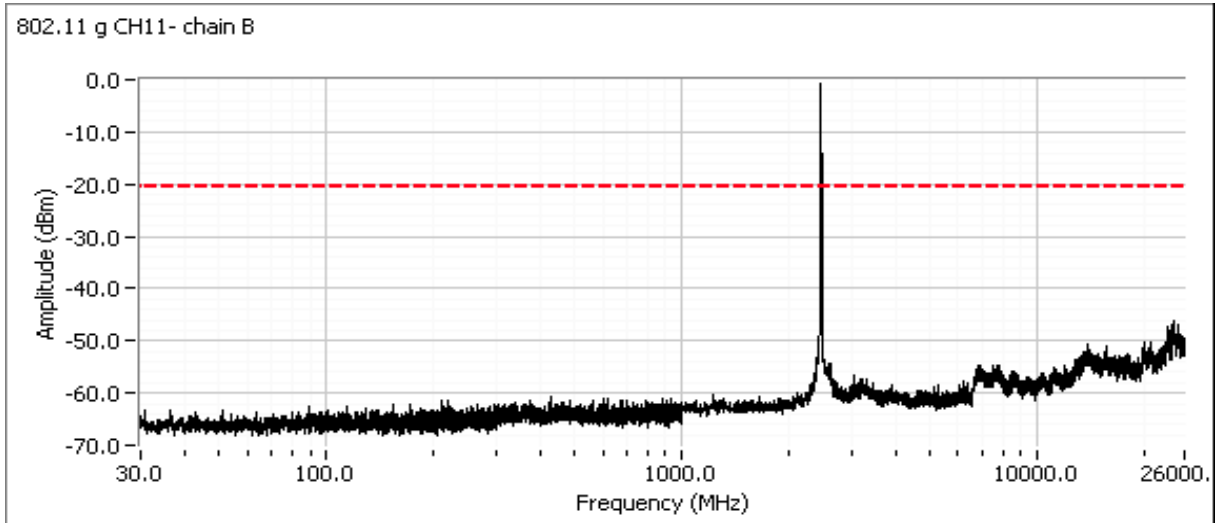

Client: Intel Corporation	Job Number: J94914
Model: 7265D2W	T-Log Number: T95471
	Project Manager: Christine Krebill
Contact: Steve Hackett	Project Coordinator: -
Standard: FCC Part 15.247, 15.407, RSS-210	Class: N/A

Run #4c: Out of Band Spurious Emissions

Mode: 802.11n20

Frequency (MHz)	Power Setting	Mode	Limit	Result
2412	29.0	n20	-20dBc	Pass
2442	29.0	n20	-20dBc	Pass
2462	22.0	n20	-20dBc	Pass

Plot for low channel

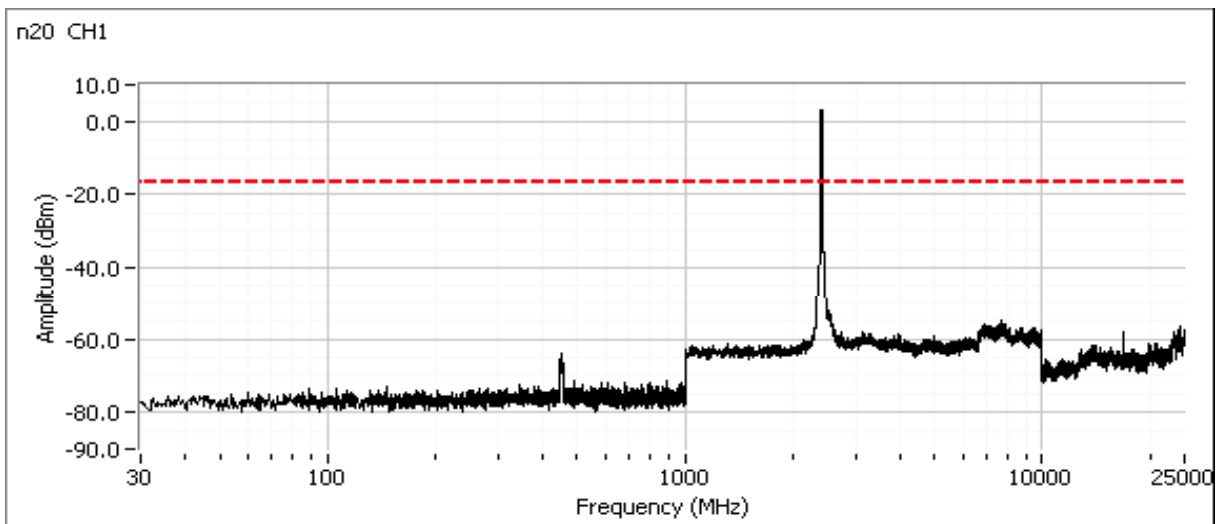

Client: Intel Corporation	Job Number: J94914
Model: 7265D2W	T-Log Number: T95471
	Project Manager: Christine Krebill
Contact: Steve Hackett	Project Coordinator: -
Standard: FCC Part 15.247, 15.407, RSS-210	Class: N/A

Additional plot showing compliance with -20dBc limit from 2390 MHz to 2400 MHz. Radiated measurements used to show compliance with the limits in the restricted band below 2390 MHz.

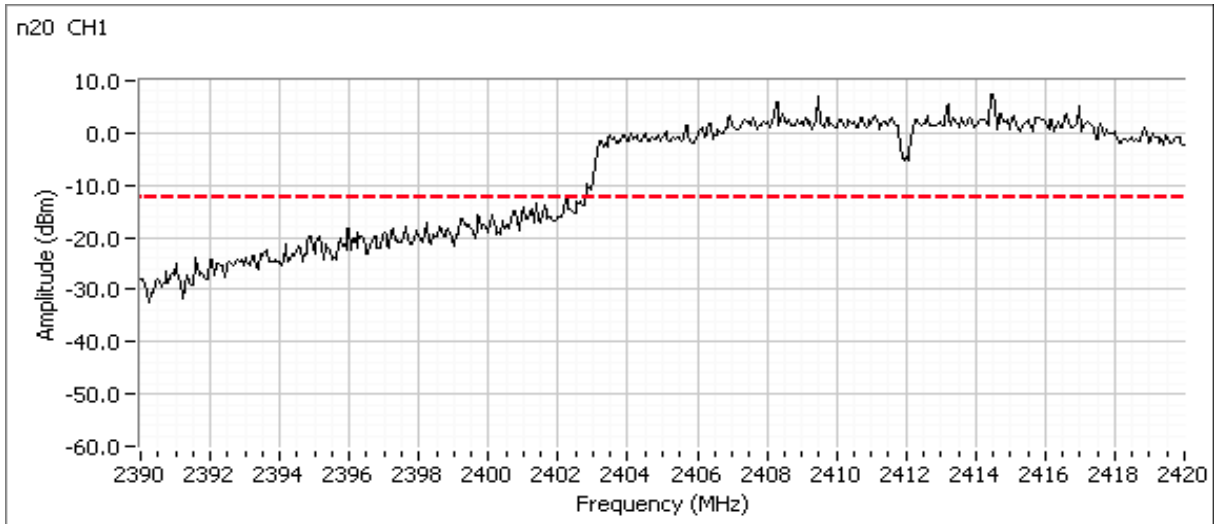

Plot for center channel

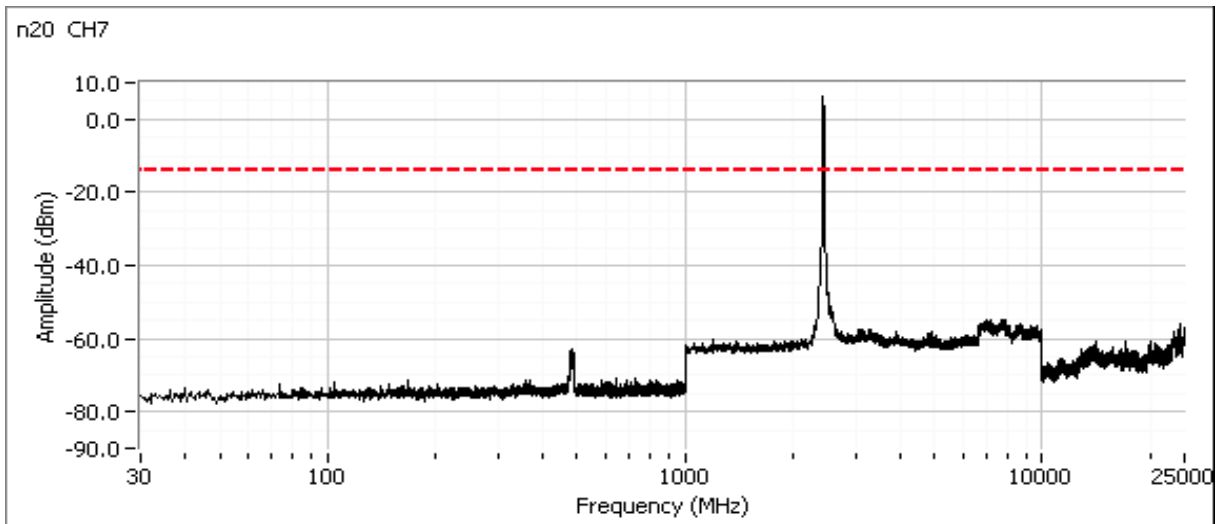

Client: Intel Corporation	Job Number: J94914
Model: 7265D2W	T-Log Number: T95471
	Project Manager: Christine Krebill
Contact: Steve Hackett	Project Coordinator: -
Standard: FCC Part 15.247, 15.407, RSS-210	Class: N/A

Plot for high channel

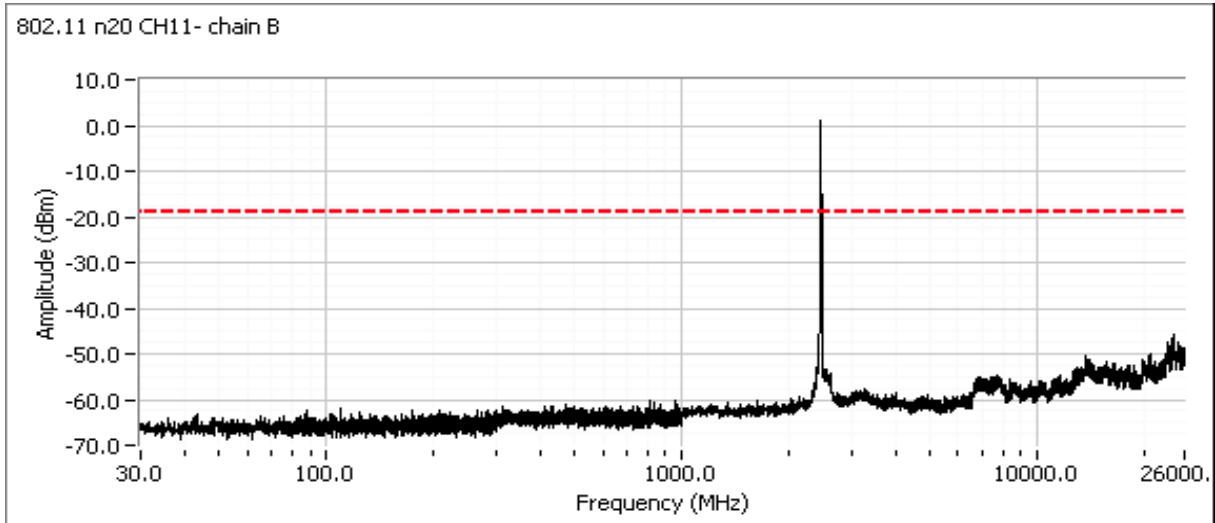

Client: Intel Corporation	Job Number: J94914
Model: 7265D2W	T-Log Number: T95471
	Project Manager: Christine Krebill
Contact: Steve Hackett	Project Coordinator: -
Standard: FCC Part 15.247, 15.407, RSS-210	Class: N/A

Run #4d: Out of Band Spurious Emissions

Mode: 802.11n40

Frequency (MHz)	Power Setting	Mode	Limit	Result
2422	28.0	n40	-20dBc	Pass
2442	28.0	n40	-20dBc	Pass
2452	20.5	n40	-20dBc	Pass

Plot for low channel

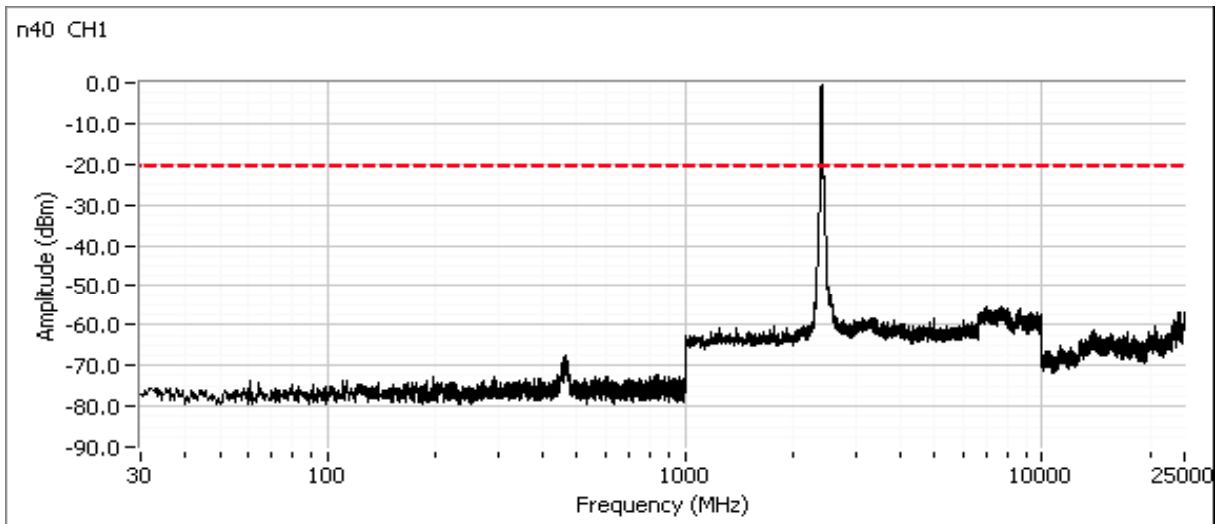

Client: Intel Corporation	Job Number: J94914
Model: 7265D2W	T-Log Number: T95471
	Project Manager: Christine Krebill
Contact: Steve Hackett	Project Coordinator: -
Standard: FCC Part 15.247, 15.407, RSS-210	Class: N/A

Additional plot showing compliance with -20dBc limit from 2390 MHz to 2400 MHz. Radiated measurements used to show compliance with the limits in the restricted band below 2390 MHz.

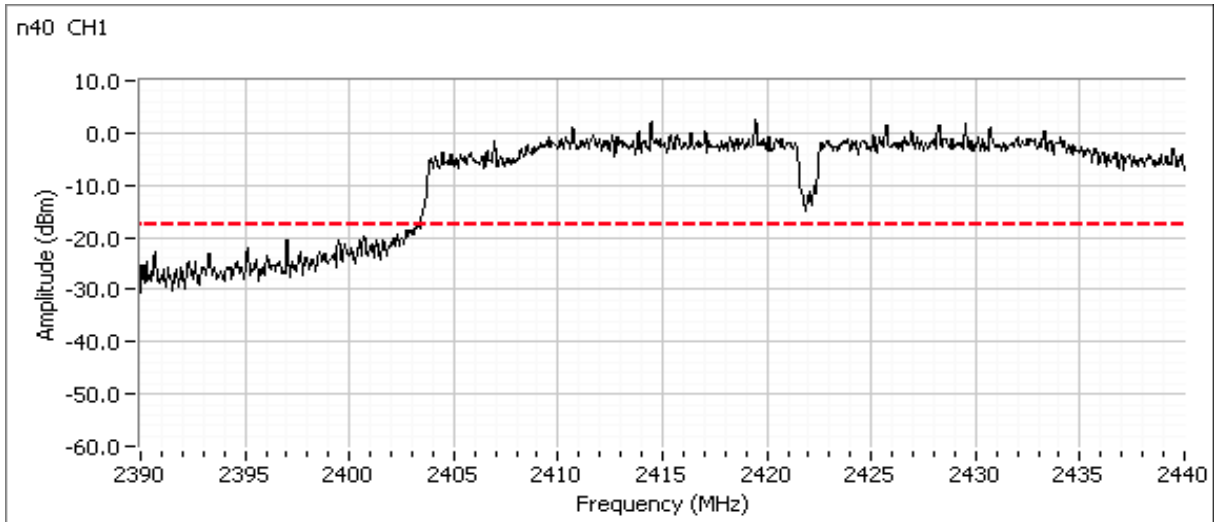

Plots for center channel

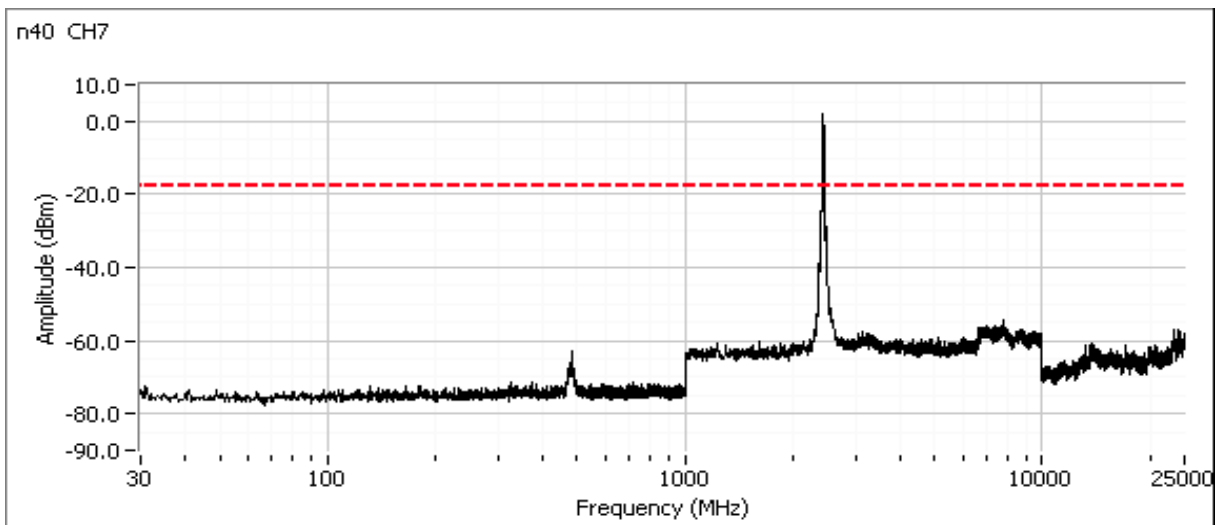

Client: Intel Corporation	Job Number: J94914
Model: 7265D2W	T-Log Number: T95471
	Project Manager: Christine Krebill
Contact: Steve Hackett	Project Coordinator: -
Standard: FCC Part 15.247, 15.407, RSS-210	Class: N/A

Plots for high channel

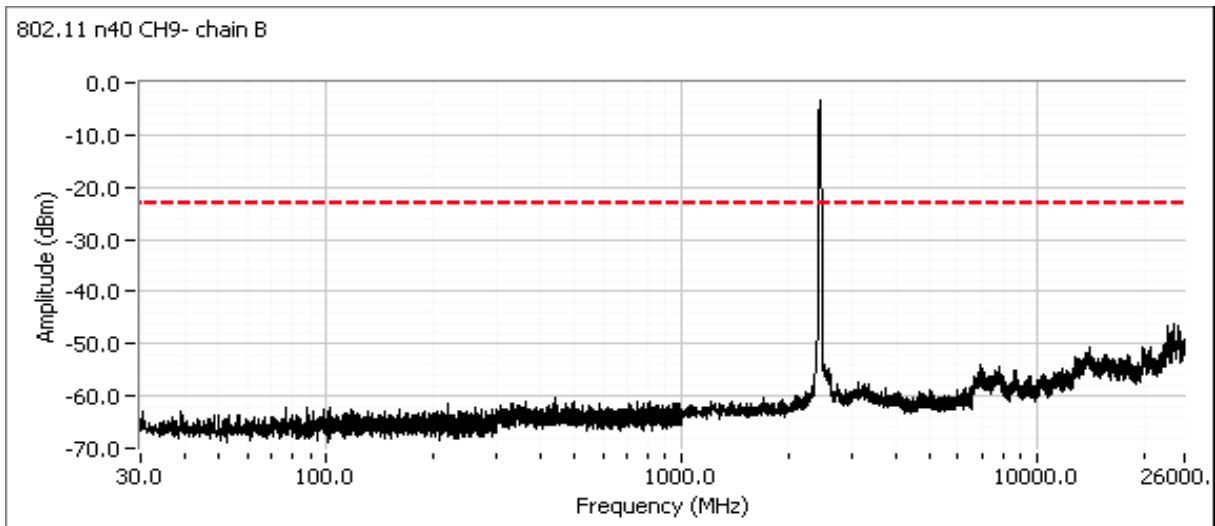



EMC Test Data

Client:	Intel Corporation	Job Number:	J94914
Model:	7265D2W	T-Log Number:	T95471
		Project Manager:	Christine Krebill
Contact:	Steve Hackett	Project Coordinator:	-
Standard:	FCC Part 15.247, 15.407, RSS-210	Class:	N/A

RSS 210 and FCC 15.247 (DTS) Antenna Port Measurements Power, PSD, Bandwidth and Spurious Emissions

Test Specific Details

Objective: The objective of this test session is to perform final qualification testing of the EUT with respect to the specification listed above.

Date of Test: 6/18/2014
 Test Engineer: J. Liu, M. Birgani
 Test Location: Lab 4A

Config. Used: 1
 Config Change: none
 EUT Voltage: 3.3Vdc

General Test Configuration

The EUT was connected to the spectrum analyzer or power meter via a suitable attenuator. All measurements were made on a single chain.

All measurements have been corrected to allow for the external attenuators used.

Ambient Conditions: Temperature: 24 °C
 Rel. Humidity: 38 %

Summary of Results

Run #	Pwr setting	Avg Pwr	Test Performed	Limit	Pass / Fail	Result / Margin
1			Output Power	15.247(b)	Pass	n20: 22.8 dBm n40: 21.8 dBm
2			Power spectral Density (PSD)	15.247(d)	Pass	n20: 0.6dBm/10kHz n40: -2.7 dBm/10kHz
3			Minimum 6dB Bandwidth	15.247(a)		These measurements are covered by the single chain data
3			99% Bandwidth	RSS GEN		
4			Spurious emissions	15.247(b)		

Modifications Made During Testing

No modifications were made to the EUT during testing

Deviations From The Standard

No deviations were made from the requirements of the standard.



EMC Test Data

Client: Intel Corporation	Job Number: J94914
Model: 7265D2W	T-Log Number: T95471
	Project Manager: Christine Krebill
Contact: Steve Hackett	Project Coordinator: -
Standard: FCC Part 15.247, 15.407, RSS-210	Class: N/A

Procedure Comments:

Measurements performed in accordance with FCC KDB 558074

Mode	Data Rate	Duty Cycle (x)	Constant DC?	T (ms)	Pwr Cor Factor*	Lin Volt Cor Factor**	Min VBW for FS (Hz)
n20	HT0	0.99	Yes	1.919	0.0	0.0	521
n40	HT0	0.97	Yes	0.944	0.1	0.2	1059

Sample Notes

MAC Address: 001500F15B5D DRTU Tool Version 1.7.3-935 Driver version 17.1.0.11

Antenna Gain Information

Freq	Antenna Gain (dBi) / Chain				BF	MultiChain Legacy	CDD	Sectorized / Xpol	Dir G (PWR)	Dir G (PSD)
	1	2	3	4						
2400-2483.5	3.2	3.2			No	No	Yes	No	3.2	6.2

For devices that support CDD modes

Min # of spatial streams: 1
 Max # of spatial streams: 2

Notes: BF = beamforming mode supported, Multichain Legacy = 802.11 legacy data rates supported for multichain transmissions, CDD = Cyclic Delay Diversity (or Cyclic Shift Diversity) modes supported, Sectorized / Xpol = antennas are sectorized or cross polarized.

Notes: Dir G (PWR) = total gain (Gant + Array Gain) for power calculations; Dir G (PSD) = total gain for PSD calculations Both are based on FCC KDB 662911. Depending on the modes supported, the Array Gain value for power could be different from the PSD value.



EMC Test Data

Client: Intel Corporation	Job Number: J94914
Model: 7265D2W	T-Log Number: T95471
	Project Manager: Christine Krebill
Contact: Steve Hackett	Project Coordinator: -
Standard: FCC Part 15.247, 15.407, RSS-210	Class: N/A

Run #1: Output Power

Operating Mode: 802.11n20
Directional Gain (dBi): 3.2

Frequency (MHz)	Chain	Software Setting	Power ¹ dBm	Total Power mW	Total Power dBm	Limit dBm	Max Power (W)	Result	Power eirp (W)	Power (dBm) ²	
2412	1	16.0	14.3	62.4	18.0	30.0	0.191	Pass	0.400	12.0	
	2	21.5	15.5							12.2	
2442	1	23.0	19.5	191.5	22.8	30.0		Pass		0.400	17.3
	2	29.0	20.1								17.4
2462	1	16.5	15.1	61.9	17.9	30.0		Pass		0.400	12.0
	2	21.0	14.7								10.3

Operating Mode: 802.11n40
Directional Gain (dBi): 3.2

Frequency (MHz)	Chain	Software Setting	Power ¹ dBm	Total Power mW	Total Power dBm	Limit dBm	Max Power (W)	Result	Power eirp (W)	Power (dBm) ²	
2422	1	14.0	11.5	27.0	14.3	30.0	0.152	Pass	0.317	9.7	
	2	19.5	11.1							9.6	
2437	1	23.0	18.8	151.7	21.8	30.0		Pass		0.317	16.7
	2	28.0	18.8								16.7
2452	1	13.5	11.7	28.9	14.6	30.0		Pass		0.317	9.4
	2	19.5	11.5								9.4

Note 1: Output power measured using a peak power meter, spurious limit is -20dBc.

Note 2: Power measured using average power meter (non-gated) and is included for reference only.



EMC Test Data

Client: Intel Corporation	Job Number: J94914
Model: 7265D2W	T-Log Number: T95471
Contact: Steve Hackett	Project Manager: Christine Krebill
Standard: FCC Part 15.247, 15.407, RSS-210	Project Coordinator: -
	Class: N/A

Run #2: Power spectral Density

Mode: n20

Power Setting	Frequency (MHz)	PSD (dBm/10kHz) ^{Note 1}				Total	Limit dBm/3kHz	Result
		Chain 1	Chain 2	Chain 3	Chain 4			
16.0 / 21.5	2412	-9.3	-7.5			-5.3	7.8	Pass
23.0 / 29.0	2442	-2.6	-2.2			0.6	7.8	Pass
16.5 / 21.0	2462	-8.7	-8.1			-5.4	7.8	Pass

Mode: n40

Power Setting	Frequency (MHz)	PSD (dBm/10kHz) ^{Note 1}				Total	Limit dBm/3kHz	Result
		Chain 1	Chain 2	Chain 3	Chain 4			
14.0 / 19.5	2422	-12.7	-14.3			-10.4	7.8	Pass
23.0 / 28.0	2437	-5.2	-6.4			-2.7	7.8	Pass
13.5 / 19.5	2462	-12.4	-14.0			-10.1	7.8	Pass

Note 1:	Test performed per method PKSPD, in KDB 558074. Power spectral density measured using: 3kHz ≤ RBW ≤ 100kHz, VBW=3*RBW, peak detector, span = 1.5*DTS BW, auto sweep time, max hold.
Note 2:	Power setting - if a single number the same power setting was used for each chain. If multiple numbers the power setting for each chain is separated by a comma (e.g. x,y would indicate power setting x for chain 1, power setting y for chain 2.

Client: Intel Corporation	Job Number: J94914
Model: 7265D2W	T-Log Number: T95471
Contact: Steve Hackett	Project Manager: Christine Krebill
Standard: FCC Part 15.247, 15.407, RSS-210	Project Coordinator: -
	Class: N/A

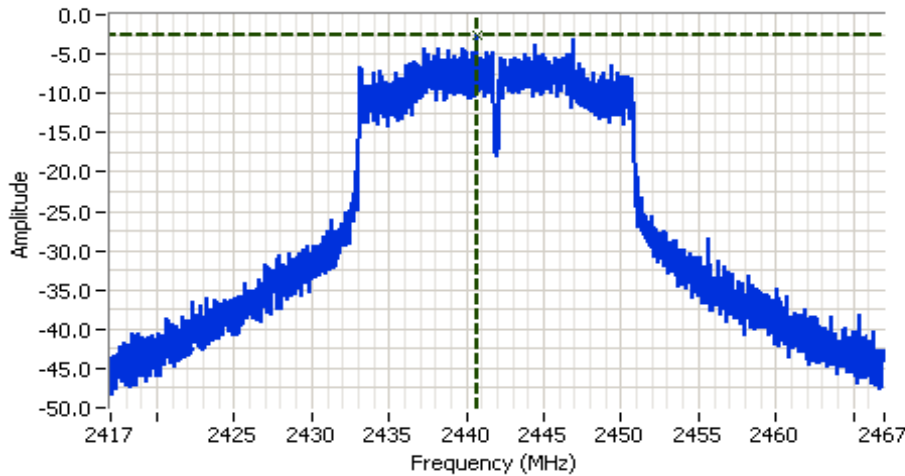

Analyzer Settings
 Agilent Technologies, E4446A
 CF: 2442.000 MHz
 SPAN: 50.000 MHz
 RB: 10.0 kHz
 VB: 30.0 kHz
 Detector: POS
 Attn: 10 DB
 RL Offset: 10.5 DB
 Sweep Time: 0.5s
 Ref Lvl: 4.0 DBM

Comments
 MIMO n20 Chain A
 PSD= -2.6dBm/10kHz

Cursor 1 2440.6746 -2.59

0.0000 0.00

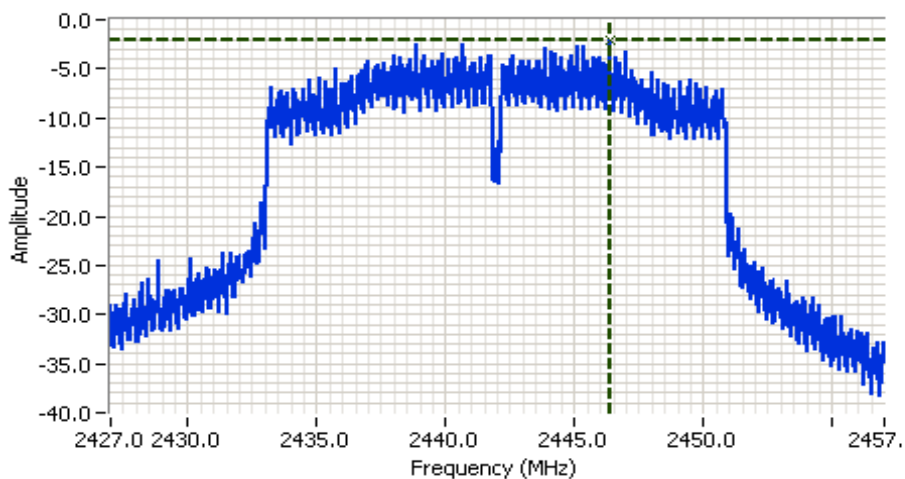

Analyzer Settings
 Agilent Technologies, E4446A
 CF: 2442.000 MHz
 SPAN: 30.000 MHz
 RB: 10.0 kHz
 VB: 30.0 kHz
 Detector: POS
 Attn: 20 DB
 RL Offset: 10.5 DB
 Sweep Time: 286.9ms
 Ref Lvl: 20.0 DBM

Comments
 MIMO n20 Chain B
 PSD= -2.18dBm/10kHz

Cursor 1 2446.3565 -2.18

0.0000 0.00





EMC Test Data

Client:	Intel Corporation	Job Number:	J94914
Model:	7265D2W	T-Log Number:	T95471
Contact:	Steve Hackett	Project Manager:	Christine Krebill
Standard:	FCC Part 15.247, 15.407, RSS-210	Project Coordinator:	-
		Class:	N/A

RSS 210 and FCC 15.247 (DTS) Radiated Spurious Emissions

Test Specific Details

Objective: The objective of this test session is to perform final qualification testing of the EUT with respect to the specification listed above.

General Test Configuration

The EUT and all local support equipment were located on the turntable for radiated spurious emissions testing. For radiated emissions testing the measurement antenna was located 3 meters from the EUT, unless otherwise noted.

Ambient Conditions:

Temperature: 25 °C
Rel. Humidity: 30 %

Summary of Results - Device Operating in the 2400-2483.5 MHz Band

Run #	Mode	Channel	Target Power	Power Setting	Test Performed	Limit	Result / Margin
1	b	1 - 2412MHz	16.5	14.5	Restricted Band Edge (2390 MHz)	FCC Part 15.209 / 15.247(c)	47.9 dBµV/m @ 2385.4 MHz (-6.1 dB)
		11 - 2462MHz	16.5	14.0	Restricted Band Edge (2483.5 MHz)		48.6 dBµV/m @ 2488.8 MHz (-5.4 dB)
2	g	1 - 2412MHz	14.0	17.0	Restricted Band Edge (2390 MHz)		47.8 dBµV/m @ 2390.0 MHz (-6.2 dB)
		2 - 2417MHz	15.5	18.5			47.5 dBµV/m @ 2390.0 MHz (-6.5 dB)
		10 - 2457MHz	15.5	18.5	Restricted Band Edge (2483.5 MHz)		47.6 dBµV/m @ 2483.6 MHz (-6.4 dB)
		11 - 2462MHz	12.5	15.0			45.3 dBµV/m @ 2483.5 MHz (-8.7 dB)
3	n20	1 - 2412MHz	14.0	17.0	Restricted Band Edge (2390 MHz)		48.2 dBµV/m @ 2390.0 MHz (-5.8 dB)
		2 - 2417MHz	15.5	19.0			48.8 dBµV/m @ 2390.0 MHz (-5.2 dB)
		10 - 2457MHz	15.5	18.5	Restricted Band Edge (2483.5 MHz)	48.9 dBµV/m @ 2483.5 MHz (-5.1 dB)	
		11 - 2462MHz	12.5	15.0		47.1 dBµV/m @ 2483.5 MHz (-6.9 dB)	



EMC Test Data

Client:	Intel Corporation	Job Number:	J94914
Model:	7265D2W	T-Log Number:	T95471
Contact:	Steve Hackett	Project Manager:	Christine Krebill
Standard:	FCC Part 15.247, 15.407, RSS-210	Project Coordinator:	-
		Class:	N/A

4	n40	3 - 2422MHz	13.5	13.5	Restricted Band Edge (2390 MHz)	FCC Part 15.209 / 15.247(c)	52.1 dBµV/m @ 2389.8 MHz (-1.9 dB)
	n40	4 - 2427MHz -	14.5	14.4	Restricted Band Edge (2483.5 MHz)		51.5 dBµV/m @ 2483.5 MHz (-2.5 dB)
	n40	7 - 2442MHz	14.5	14.5	Restricted Band Edge (2483.5 MHz)		50.4 dBµV/m @ 2483.5 MHz (-3.6 dB)
	n40	8 - 2447MHz	13.5	13.7	Restricted Band Edge (2483.5 MHz)		52.4 dBµV/m @ 2483.5 MHz (-1.6 dB)
	n40	9 - 2452MHz	12.5	12.8	Restricted Band Edge (2483.5 MHz)		52.3 dBµV/m @ 2483.5 MHz (-1.7 dB)

Modifications Made During Testing

No modifications were made to the EUT during testing

Deviations From The Standard

No deviations were made from the requirements of the standard.

Sample Notes

MAC Address: 001500F15B5D DRTU Tool Version 1.7.3-935 Driver version 17.1.0.11

Antenna: Skycross WiMax/WLAN



EMC Test Data

Client:	Intel Corporation	Job Number:	J94914
Model:	7265D2W	T-Log Number:	T95471
Contact:	Steve Hackett	Project Manager:	Christine Krebill
Standard:	FCC Part 15.247, 15.407, RSS-210	Project Coordinator:	-
		Class:	N/A

Procedure Comments:

Measurements performed in accordance with FCC KDB 558074

Peak measurements performed with: RBW=1MHz, VBW=3MHz, peak detector, max hold, auto sweep time

Unless otherwise stated/noted, emission has duty cycle $\geq 98\%$ and was measured using RBW=1MHz, VBW=10Hz, peak detector, linear average mode, auto sweep time, max hold.

Mode	Data Rate	Duty Cycle (x)	Constant DC?	T (ms)	Pwr Cor Factor*	Lin Volt Cor Factor**	Min VBW for FS (Hz)
11b	1	0.99	Yes	2.272	0.0	0.0	440
11g	6	0.99	Yes	2.06	0.0	0.0	485
n20	HT0	0.99	Yes	1.919	0.0	0.0	521
n40	HT0	0.97	Yes	0.944	0.1	0.2	1059

Measurement Specific Notes:

Note 1:	Emission in non-restricted band, but limit of 15.209 used.
Note 2:	Emission in non-restricted band, the limit was set 20dB below the level of the fundamental and measured in 100kHz.
Note 3:	Emission has duty cycle $< 98\%$, but constant, average measurement performed: RBW=1MHz, VBW=10Hz, peak detector, linear averaging, auto sweep, trace average 100 traces, measurement corrected by Linear Voltage correction factor
Note 4:	Plots of the average bandedge do not account for any duty cycle correction. Refer to the tabular results for final measurements.



EMC Test Data

Client: Intel Corporation	Job Number: J94914
Model: 7265D2W	T-Log Number: T95471
Contact: Steve Hackett	Project Manager: Christine Krebill
Standard: FCC Part 15.247, 15.407, RSS-210	Project Coordinator: -
	Class: N/A

Run #1: Radiated Bandedge Measurements

Date of Test: 6/6/2014 0:00
 Test Engineer: John Caizzi
 Test Location: Chamber 7

Config. Used: 1
 Config Change: none
 EUT Voltage: 3.3 VDC

Channel: 1 Mode: b
 Tx Chain: A Data Rate: 1

Power Settings		
Target (dBm)	Measured (dBm)	Software Setting
16.5	16.8	14.5

Band Edge Signal Field Strength - Direct measurement of field strength

Frequency	Level	Pol	15.209 / 15.247		Detector	Azimuth	Height	Comments
MHz	dB μ V/m	v/h	Limit	Margin	Pk/QP/Avg	degrees	meters	
2385.270	47.1	V	54.0	-6.9	AVG	278	1.04	POS; RB 1 MHz; VB: 10 Hz
2379.820	52.9	V	74.0	-21.1	PK	278	1.04	POS; RB 1 MHz; VB: 3 MHz
2385.350	47.9	H	54.0	-6.1	AVG	308	1.00	POS; RB 1 MHz; VB: 10 Hz
2385.510	53.8	H	74.0	-20.2	PK	308	1.00	POS; RB 1 MHz; VB: 3 MHz

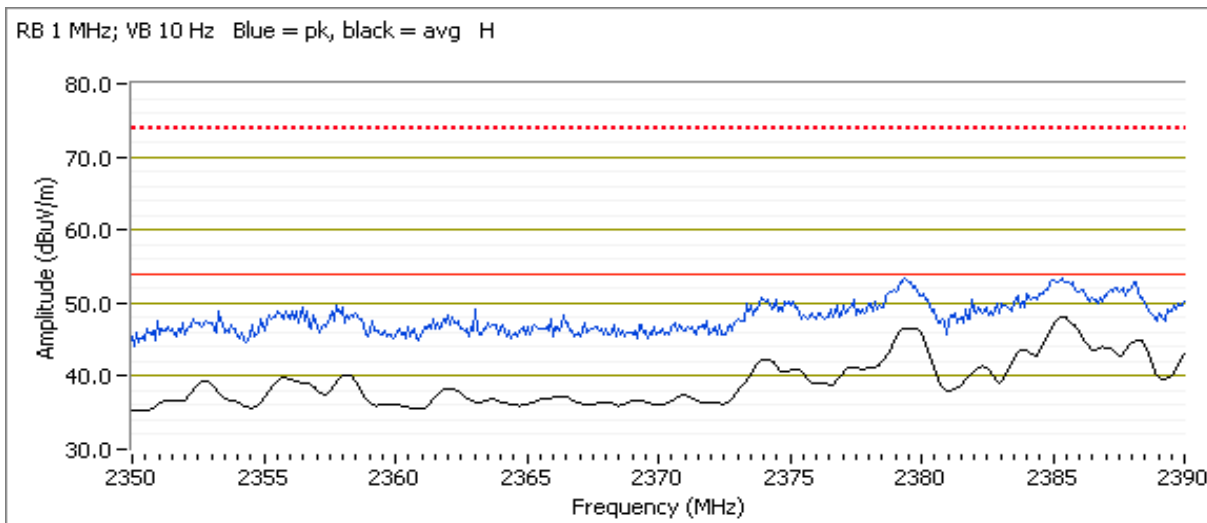



EMC Test Data

Client:	Intel Corporation	Job Number:	J94914
Model:	7265D2W	T-Log Number:	T95471
Contact:	Steve Hackett	Project Manager:	Christine Krebill
Standard:	FCC Part 15.247, 15.407, RSS-210	Project Coordinator:	-
		Class:	N/A

Channel: 11 Mode: b
 Tx Chain: A Data Rate: 1

Power Settings		
Target (dBm)	Measured (dBm)	Software Setting
16.5	16.7	14.0

Band Edge Signal Field Strength - Direct measurement of field strength

Frequency MHz	Level dB μ V/m	Pol v/h	15.209 / 15.247		Detector Pk/QP/Avg	Azimuth degrees	Height meters	Comments
			Limit	Margin				
2488.720	46.5	V	54.0	-7.5	AVG	279	1.11	POS; RB 1 MHz; VB: 10 Hz
2485.880	52.8	V	74.0	-21.2	PK	279	1.11	POS; RB 1 MHz; VB: 3 MHz
2488.760	48.6	H	54.0	-5.4	AVG	252	1.12	POS; RB 1 MHz; VB: 10 Hz
2485.720	54.6	H	74.0	-19.4	PK	252	1.12	POS; RB 1 MHz; VB: 3 MHz

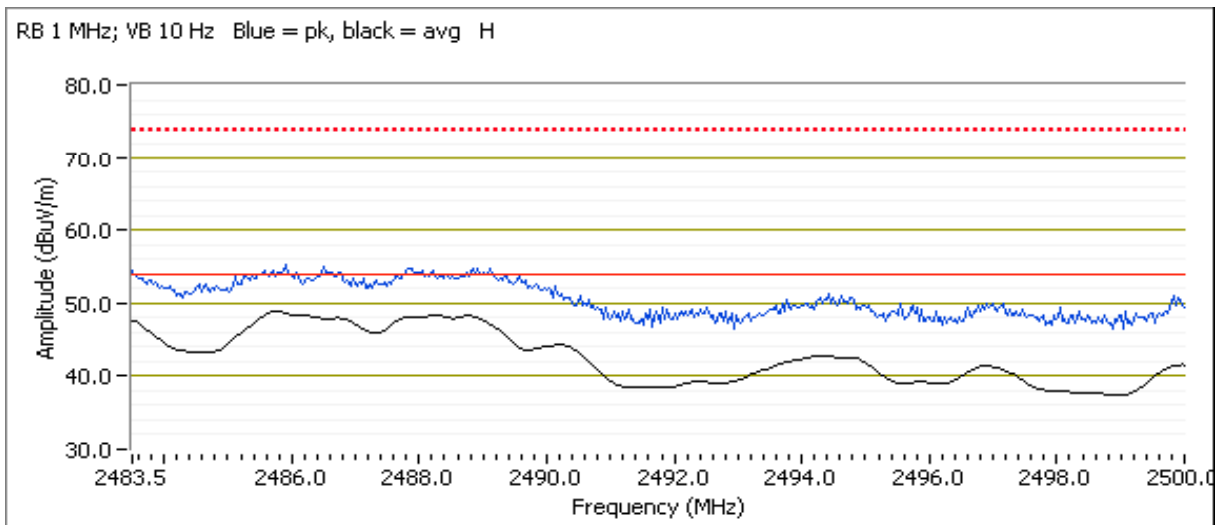



EMC Test Data

Client: Intel Corporation	Job Number: J94914
Model: 7265D2W	T-Log Number: T95471
Contact: Steve Hackett	Project Manager: Christine Krebill
Standard: FCC Part 15.247, 15.407, RSS-210	Project Coordinator: -
	Class: N/A

Run #2: Radiated Bandedge Measurements

Date of Test: 6/6/2014 0:00
 Test Engineer: John Caizzi
 Test Location: Chamber 7

Config. Used: 1
 Config Change: none
 EUT Voltage: 3.3 VDC

Channel: 1 Mode: g
 Tx Chain: A Data Rate: 6

Power Settings		
Target (dBm)	Measured (dBm)	Software Setting
14.0	14.2	17.0

Band Edge Signal Field Strength - Direct measurement of field strength

Frequency MHz	Level dB μ V/m	Pol v/h	15.209 / 15.247		Detector Pk/QP/Avg	Azimuth degrees	Height meters	Comments
			Limit	Margin				
2390.000	46.2	V	54.0	-7.8	AVG	282	1.00	POS; RB 1 MHz; VB: 10 Hz
2389.280	58.0	V	74.0	-16.0	PK	282	1.00	POS; RB 1 MHz; VB: 3 MHz
2390.000	47.8	H	54.0	-6.2	AVG	249	1.46	POS; RB 1 MHz; VB: 10 Hz
2389.920	59.9	H	74.0	-14.1	PK	249	1.46	POS; RB 1 MHz; VB: 3 MHz

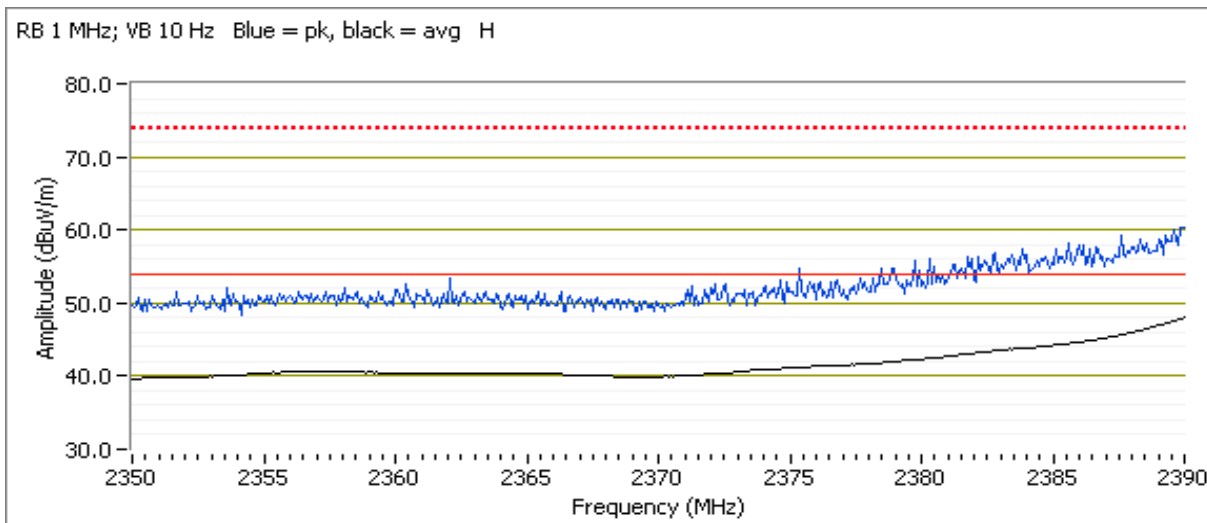



EMC Test Data

Client:	Intel Corporation	Job Number:	J94914
Model:	7265D2W	T-Log Number:	T95471
Contact:	Steve Hackett	Project Manager:	Christine Krebill
Standard:	FCC Part 15.247, 15.407, RSS-210	Project Coordinator:	-
		Class:	N/A

Channel: 2 Mode: g
 Tx Chain: A Data Rate: 6

Power Settings		
Target (dBm)	Measured (dBm)	Software Setting
15.5	15.5	18.5

Band Edge Signal Field Strength - Direct measurement of field strength

Frequency	Level	Pol	15.209 / 15.247		Detector	Azimuth	Height	Comments
MHz	dB μ V/m	v/h	Limit	Margin	Pk/QP/Avg	degrees	meters	
2390.000	45.9	V	54.0	-8.1	AVG	282	1.00	POS; RB 1 MHz; VB: 10 Hz
2387.350	60.6	V	74.0	-13.4	PK	282	1.00	POS; RB 1 MHz; VB: 3 MHz
2390.000	47.5	H	54.0	-6.5	AVG	249	1.45	POS; RB 1 MHz; VB: 10 Hz
2384.790	60.5	H	74.0	-13.5	PK	249	1.45	POS; RB 1 MHz; VB: 3 MHz

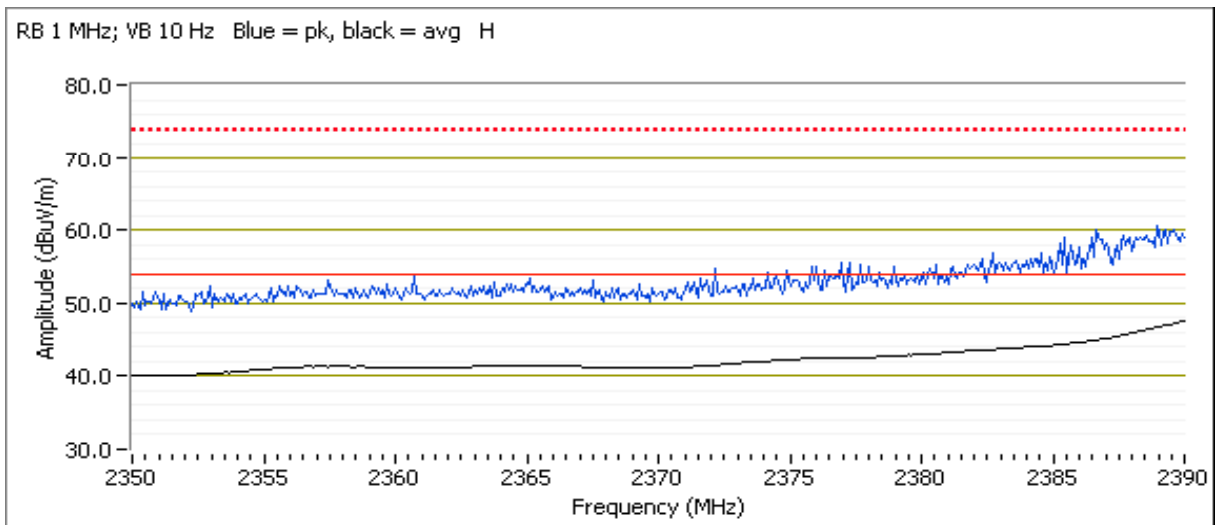



EMC Test Data

Client:	Intel Corporation	Job Number:	J94914
Model:	7265D2W	T-Log Number:	T95471
Contact:	Steve Hackett	Project Manager:	Christine Krebill
Standard:	FCC Part 15.247, 15.407, RSS-210	Project Coordinator:	-
		Class:	N/A

Channel: 10 Mode: g
 Tx Chain: A Data Rate: 6

Power Settings		
Target (dBm)	Measured (dBm)	Software Setting
15.5	15.8	18.5

Band Edge Signal Field Strength - Direct measurement of field strength

Frequency MHz	Level dB μ V/m	Pol v/h	15.209 / 15.247		Detector Pk/QP/Avg	Azimuth degrees	Height meters	Comments
			Limit	Margin				
2483.500	45.8	V	54.0	-8.2	AVG	215	1.60	POS; RB 1 MHz; VB: 10 Hz
2485.550	59.7	V	74.0	-14.3	PK	215	1.60	POS; RB 1 MHz; VB: 3 MHz
2483.570	47.6	H	54.0	-6.4	AVG	230	1.57	POS; RB 1 MHz; VB: 10 Hz
2485.880	62.3	H	74.0	-11.7	PK	230	1.57	POS; RB 1 MHz; VB: 3 MHz

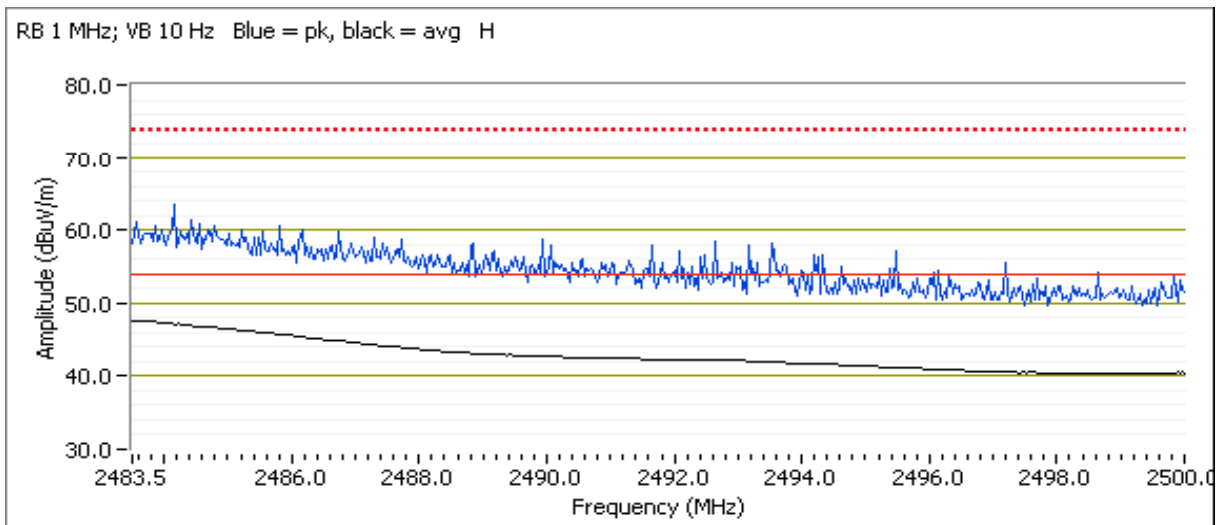



EMC Test Data

Client: Intel Corporation	Job Number: J94914
Model: 7265D2W	T-Log Number: T95471
Contact: Steve Hackett	Project Manager: Christine Krebill
Standard: FCC Part 15.247, 15.407, RSS-210	Project Coordinator: -
	Class: N/A

Channel: 11 Mode: g
 Tx Chain: A Data Rate: 6

Power Settings		
Target (dBm)	Measured (dBm)	Software Setting
12.5	12.8	15.0

Band Edge Signal Field Strength - Direct measurement of field strength

Frequency MHz	Level dB μ V/m	Pol v/h	15.209 / 15.247		Detector Pk/QP/Avg	Azimuth degrees	Height meters	Comments
			Limit	Margin				
2483.570	44.6	V	54.0	-9.4	AVG	225	1.59	POS; RB 1 MHz; VB: 10 Hz
2484.130	58.1	V	74.0	-15.9	PK	225	1.59	POS; RB 1 MHz; VB: 3 MHz
2483.500	45.3	H	54.0	-8.7	AVG	230	1.57	POS; RB 1 MHz; VB: 10 Hz
2485.320	58.7	H	74.0	-15.3	PK	230	1.57	POS; RB 1 MHz; VB: 3 MHz

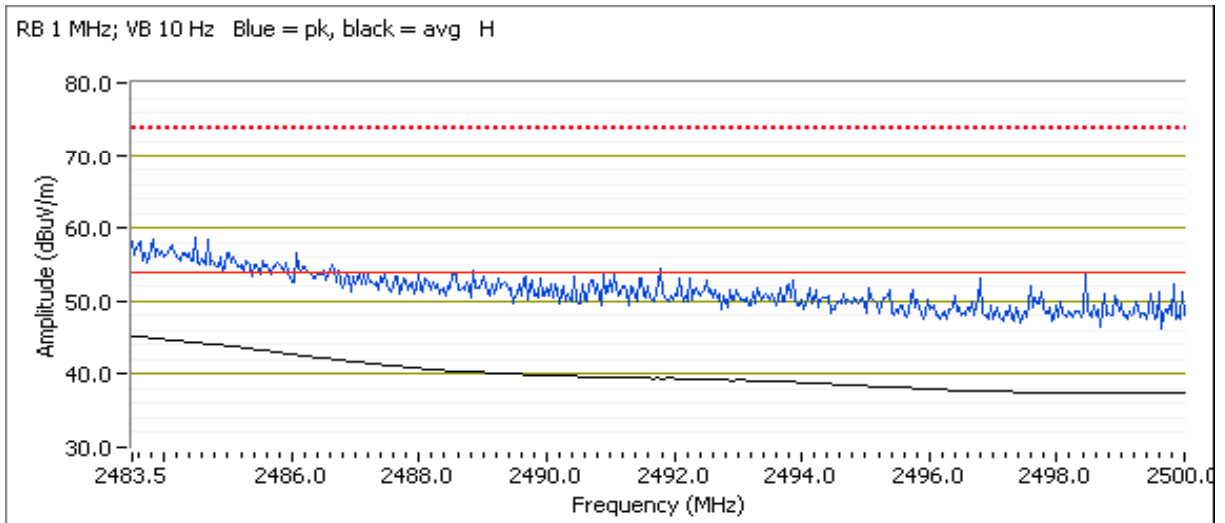



EMC Test Data

Client: Intel Corporation	Job Number: J94914
Model: 7265D2W	T-Log Number: T95471
Contact: Steve Hackett	Project Manager: Christine Krebill
Standard: FCC Part 15.247, 15.407, RSS-210	Project Coordinator: -
	Class: N/A

Run #3: Radiated Bandedge Measurements

Date of Test: 6/6/2014 0:00
 Test Engineer: John Caizzi
 Test Location: Chamber 7

Config. Used: 1
 Config Change: none
 EUT Voltage: 3.3 VDC

Channel: 1 Mode: n20
 Tx Chain: A Data Rate: HT0

Power Settings		
Target (dBm)	Measured (dBm)	Software Setting
14.0	14.1	17.0

Band Edge Signal Field Strength - Direct measurement of field strength

Frequency MHz	Level dB μ V/m	Pol v/h	15.209 / 15.247		Detector Pk/QP/Avg	Azimuth degrees	Height meters	Comments
			Limit	Margin				
2390.000	45.1	V	54.0	-8.9	AVG	278	1.00	POS; RB 1 MHz; VB: 10 Hz
2384.630	58.4	V	74.0	-15.6	PK	278	1.00	POS; RB 1 MHz; VB: 3 MHz
2390.000	48.2	H	54.0	-5.8	AVG	248	1.44	POS; RB 1 MHz; VB: 10 Hz
2389.760	62.9	H	74.0	-11.1	PK	248	1.44	POS; RB 1 MHz; VB: 3 MHz

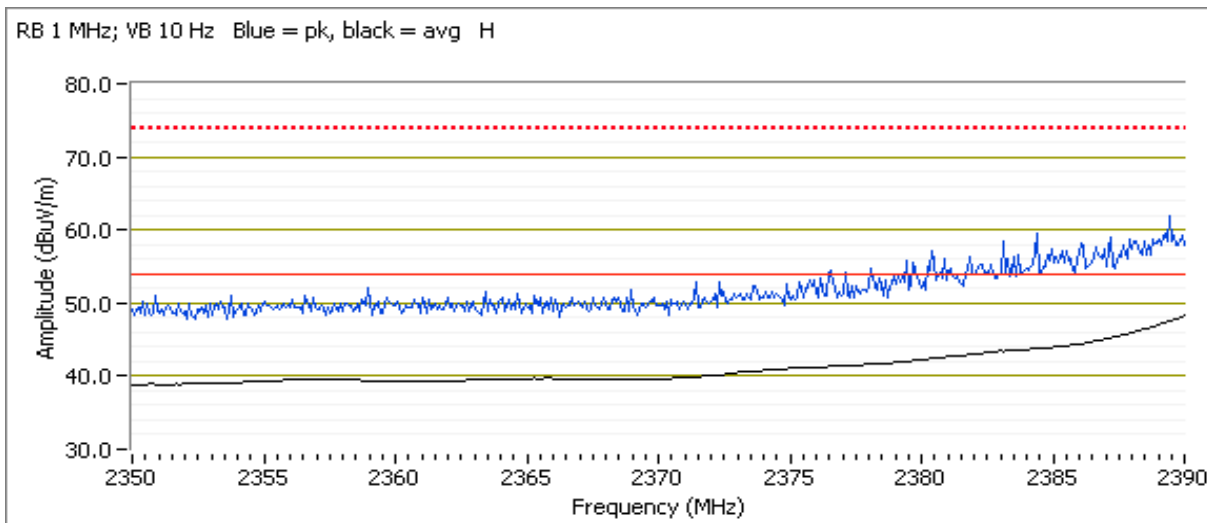



EMC Test Data

Client: Intel Corporation	Job Number: J94914
Model: 7265D2W	T-Log Number: T95471
Contact: Steve Hackett	Project Manager: Christine Krebill
Standard: FCC Part 15.247, 15.407, RSS-210	Project Coordinator: -
	Class: N/A

Channel: 2 Mode: n20
 Tx Chain: A Data Rate: HT0

Power Settings		
Target (dBm)	Measured (dBm)	Software Setting
15.5	15.8	19.0

Band Edge Signal Field Strength - Direct measurement of field strength

Frequency	Level	Pol	15.209 / 15.247		Detector	Azimuth	Height	Comments
MHz	dB μ V/m	v/h	Limit	Margin	Pk/QP/Avg	degrees	meters	
2390.000	48.0	V	54.0	-6.0	AVG	278	1.00	POS; RB 1 MHz; VB: 10 Hz
2389.920	59.8	V	74.0	-14.2	PK	278	1.00	POS; RB 1 MHz; VB: 3 MHz
2390.000	48.8	H	54.0	-5.2	AVG	244	1.00	POS; RB 1 MHz; VB: 10 Hz
2389.120	62.2	H	74.0	-11.8	PK	244	1.00	POS; RB 1 MHz; VB: 3 MHz

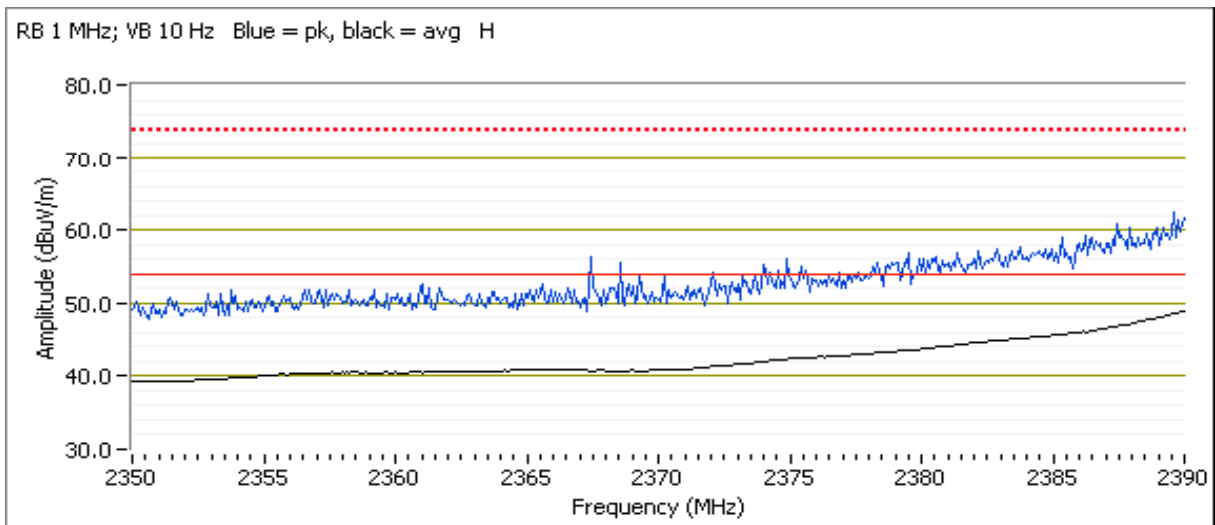



EMC Test Data

Client: Intel Corporation	Job Number: J94914
Model: 7265D2W	T-Log Number: T95471
Contact: Steve Hackett	Project Manager: Christine Krebill
Standard: FCC Part 15.247, 15.407, RSS-210	Project Coordinator: -
	Class: N/A

Channel: 10 Mode: n20
 Tx Chain: A Data Rate: HT0

Power Settings		
Target (dBm)	Measured (dBm)	Software Setting
15.5	15.7	18.5

Band Edge Signal Field Strength - Direct measurement of field strength

Frequency MHz	Level dB μ V/m	Pol v/h	15.209 / 15.247		Detector Pk/QP/Avg	Azimuth degrees	Height meters	Comments
			Limit	Margin				
2483.500	46.6	V	54.0	-7.4	AVG	279	1.13	POS; RB 1 MHz; VB: 10 Hz
2483.930	61.1	V	74.0	-12.9	PK	279	1.13	POS; RB 1 MHz; VB: 3 MHz
2483.530	48.9	H	54.0	-5.1	AVG	252	1.14	POS; RB 1 MHz; VB: 10 Hz
2483.960	62.7	H	74.0	-11.3	PK	252	1.14	POS; RB 1 MHz; VB: 3 MHz

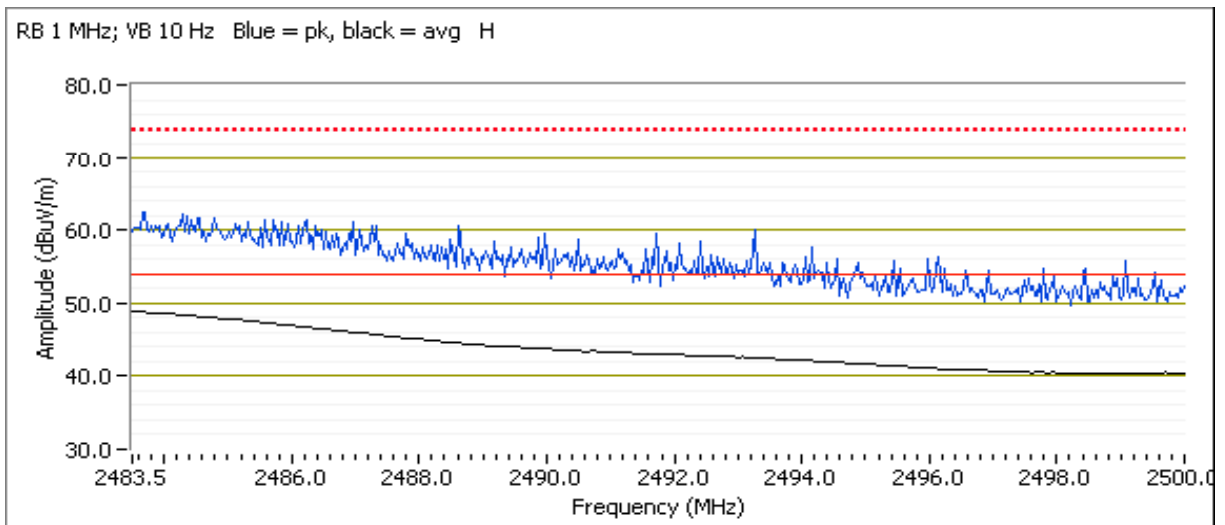



EMC Test Data

Client: Intel Corporation	Job Number: J94914
Model: 7265D2W	T-Log Number: T95471
Contact: Steve Hackett	Project Manager: Christine Krebill
Standard: FCC Part 15.247, 15.407, RSS-210	Project Coordinator: -
	Class: N/A

Channel: 11 Mode: n20
 Tx Chain: A Data Rate: HT0

Power Settings		
Target (dBm)	Measured (dBm)	Software Setting
12.5	12.6	15.0

Band Edge Signal Field Strength - Direct measurement of field strength

Frequency MHz	Level dB μ V/m	Pol v/h	15.209 / 15.247		Detector Pk/QP/Avg	Azimuth degrees	Height meters	Comments
			Limit	Margin				
2483.530	47.1	H	54.0	-6.9	AVG	251	1.11	POS; RB 1 MHz; VB: 10 Hz
2483.900	61.6	H	74.0	-12.4	PK	251	1.11	POS; RB 1 MHz; VB: 3 MHz
2483.570	44.5	V	54.0	-9.5	AVG	281	1.11	POS; RB 1 MHz; VB: 10 Hz
2485.320	58.0	V	74.0	-16.0	PK	281	1.11	POS; RB 1 MHz; VB: 3 MHz

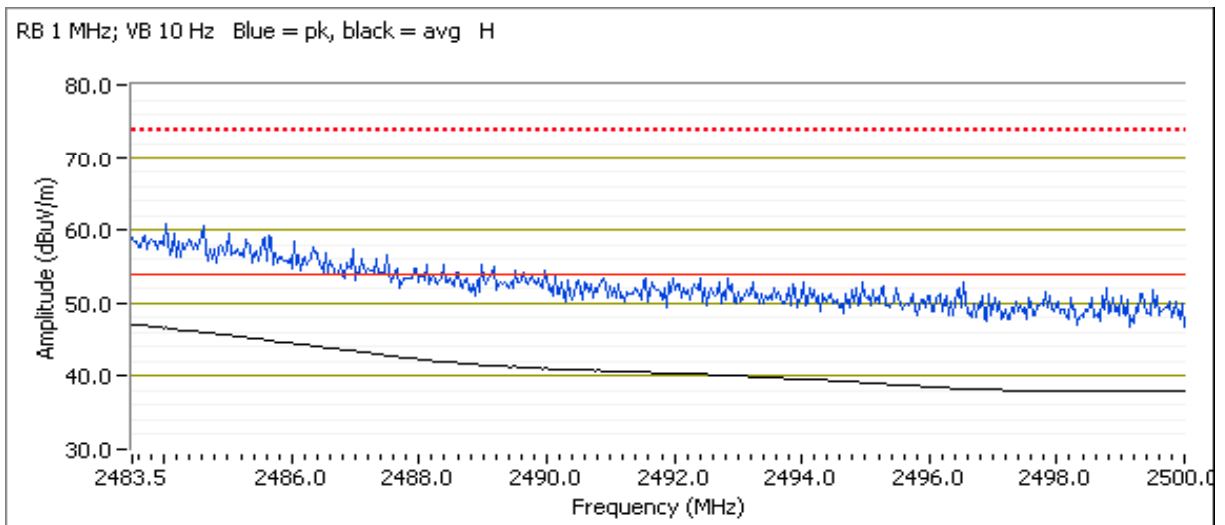



EMC Test Data

Client: Intel Corporation	Job Number: J94914
Model: 7265D2W	T-Log Number: T95471
Contact: Steve Hackett	Project Manager: Christine Krebill
Standard: FCC Part 15.247, 15.407, RSS-210	Project Coordinator: -
	Class: N/A

Run #4: Radiated Bandedge Measurements

Date of Test: 6/6/2014 0:00
 Test Engineer: Joseph Cadigal
 Test Location: FT Chamber#7

Config. Used: 1
 Config Change: none
 EUT Voltage: 3.3 VDC

Channel: 3 Mode: n40
 Tx Chain: A Data Rate: HT0

Power Settings		
Target (dBm)	Measured (dBm)	Software Setting
13.5	13.5	16.5

Band Edge Signal Field Strength - Direct measurement of field strength

Frequency MHz	Level dB μ V/m	Pol v/h	15.209 / 15.247		Detector Pk/QP/Avg	Azimuth degrees	Height meters	Comments
			Limit	Margin				
2389.840	52.1	H	54.0	-1.9	AVG	304	1.2	POS; RB 1 MHz; VB: 10 Hz, Note 3
2389.600	62.3	H	74.0	-11.7	PK	304	1.2	POS; RB 1 MHz; VB: 3 MHz
2389.840	48.3	V	54.0	-5.7	AVG	276	1.3	POS; RB 1 MHz; VB: 10 Hz, Note 3
2388.880	59.5	V	74.0	-14.5	PK	276	1.3	POS; RB 1 MHz; VB: 3 MHz

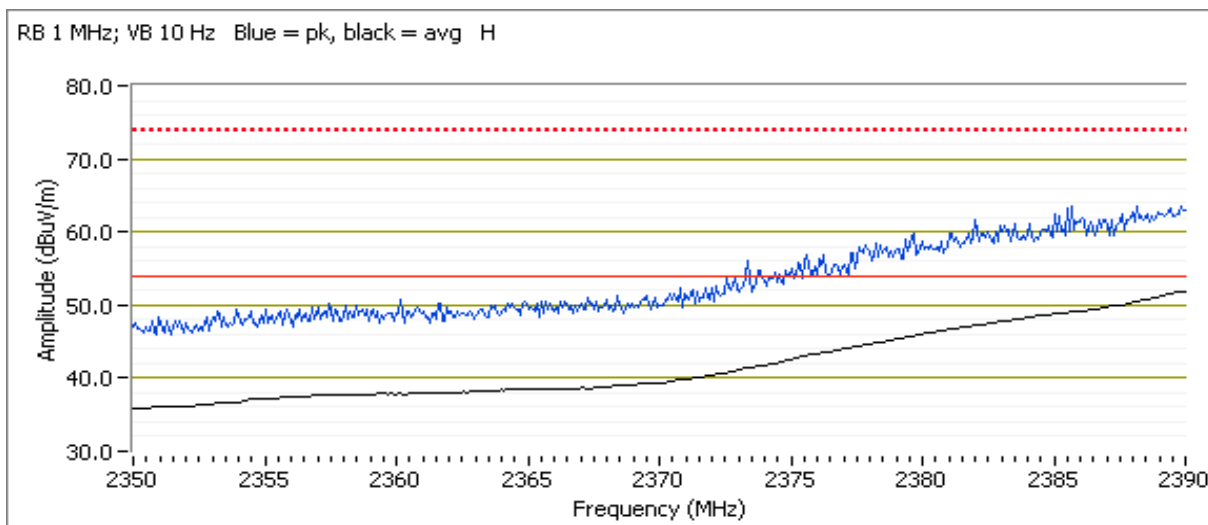



EMC Test Data

Client: Intel Corporation	Job Number: J94914
Model: 7265D2W	T-Log Number: T95471
Contact: Steve Hackett	Project Manager: Christine Krebill
Standard: FCC Part 15.247, 15.407, RSS-210	Project Coordinator: -
	Class: N/A

Channel: 4 Mode: n40
 Tx Chain: A Data Rate: HT0

Power Settings		
Target (dBm)	Measured (dBm)	Software Setting
14.5	14.4	17.5

Band Edge Signal Field Strength - Direct measurement of field strength

Frequency MHz	Level dB μ V/m	Pol v/h	15.209 / 15.247		Detector Pk/QP/Avg	Azimuth degrees	Height meters	Comments
			Limit	Margin				
2483.500	51.5	H	54.0	-2.5	AVG	304	1.2	POS; RB 1 MHz; VB: 10 Hz, Note 3
2483.500	62.3	H	74.0	-11.7	PK	304	1.2	POS; RB 1 MHz; VB: 3 MHz
2483.500	48.5	V	54.0	-5.5	AVG	276	1.1	POS; RB 1 MHz; VB: 10 Hz, Note 3
2483.500	58.6	V	74.0	-15.4	PK	276	1.1	POS; RB 1 MHz; VB: 3 MHz

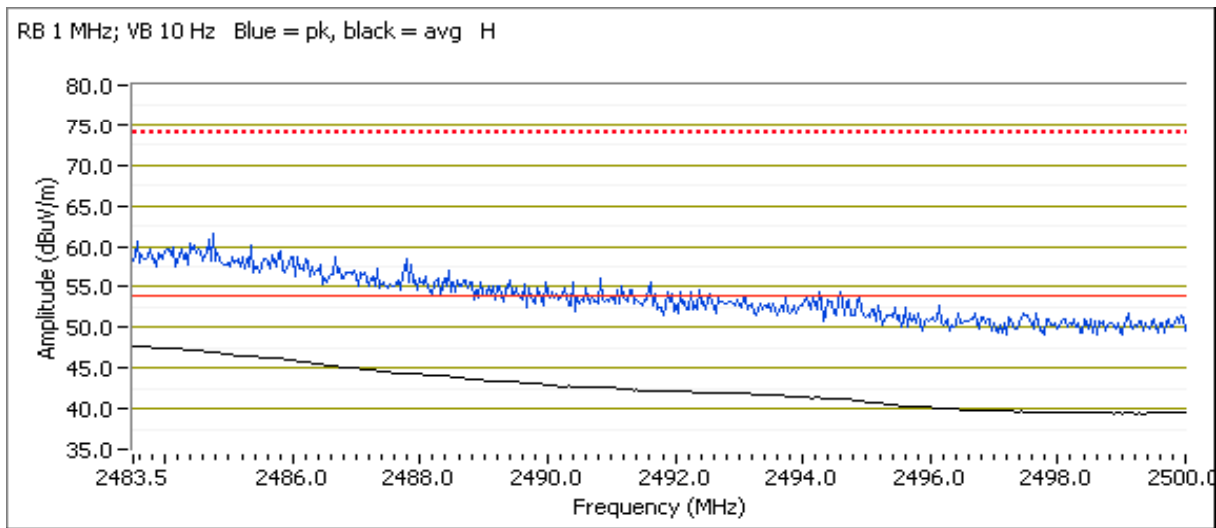



EMC Test Data

Client: Intel Corporation	Job Number: J94914
Model: 7265D2W	T-Log Number: T95471
Contact: Steve Hackett	Project Manager: Christine Krebill
Standard: FCC Part 15.247, 15.407, RSS-210	Project Coordinator: -
	Class: N/A

Channel: 7 Mode: n40
 Tx Chain: A Data Rate: HT0

Power Settings		
Target (dBm)	Measured (dBm)	Software Setting
14.5	14.5	17.5

Band Edge Signal Field Strength - Direct measurement of field strength

Frequency MHz	Level dB μ V/m	Pol v/h	15.209 / 15.247		Detector Pk/QP/Avg	Azimuth degrees	Height meters	Comments
			Limit	Margin				
2483.500	50.4	V	54.0	-3.6	AVG	274	1.1	POS; RB 1 MHz; VB: 10 Hz, Note 3
2483.930	60.7	V	74.0	-13.3	PK	274	1.1	POS; RB 1 MHz; VB: 3 MHz
2483.500	48.0	H	54.0	-6.0	AVG	299	1.0	POS; RB 1 MHz; VB: 10 Hz, Note 3
2483.730	59.8	H	74.0	-14.2	PK	299	1.0	POS; RB 1 MHz; VB: 3 MHz

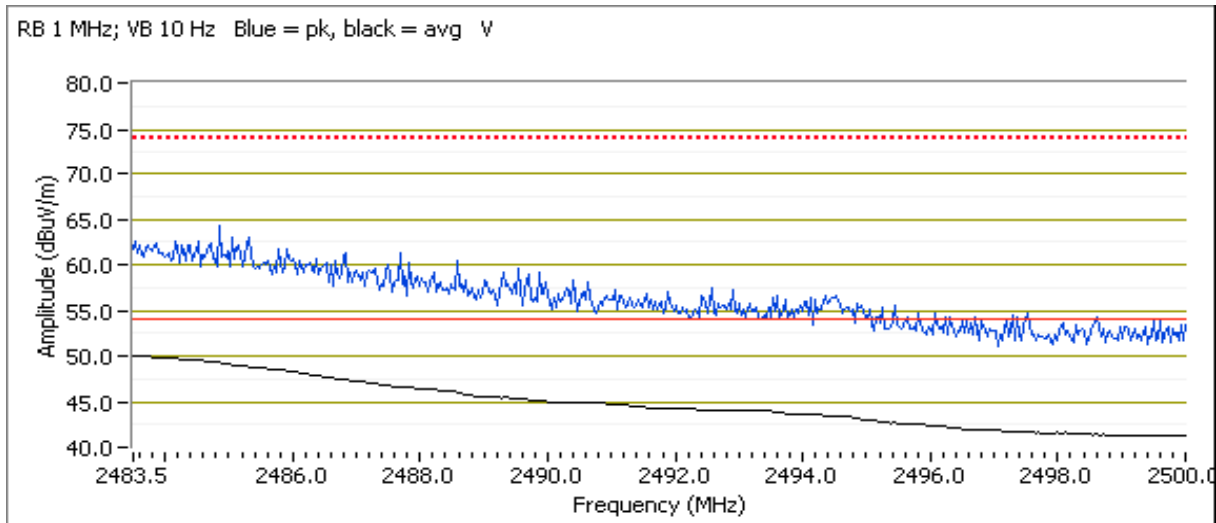



EMC Test Data

Client: Intel Corporation	Job Number: J94914
Model: 7265D2W	T-Log Number: T95471
Contact: Steve Hackett	Project Manager: Christine Krebill
Standard: FCC Part 15.247, 15.407, RSS-210	Project Coordinator: -
	Class: N/A

Channel: 8 Mode: n40
 Tx Chain: A Data Rate: HT0

Power Settings		
Target (dBm)	Measured (dBm)	Software Setting
13.5	13.7	16.5

Band Edge Signal Field Strength - Direct measurement of field strength

Frequency MHz	Level dB μ V/m	Pol v/h	15.209 / 15.247		Detector Pk/QP/Avg	Azimuth degrees	Height meters	Comments
			Limit	Margin				
2483.530	52.4	H	54.0	-1.6	AVG	194	1.0	POS; RB 1 MHz; VB: 10 Hz, Note 3
2484.100	65.4	H	74.0	-8.6	PK	194	1.0	POS; RB 1 MHz; VB: 3 MHz
2483.530	51.5	V	54.0	-2.5	AVG	275	1.1	POS; RB 1 MHz; VB: 10 Hz, Note 3
2483.670	62.0	V	74.0	-12.0	PK	275	1.1	POS; RB 1 MHz; VB: 3 MHz

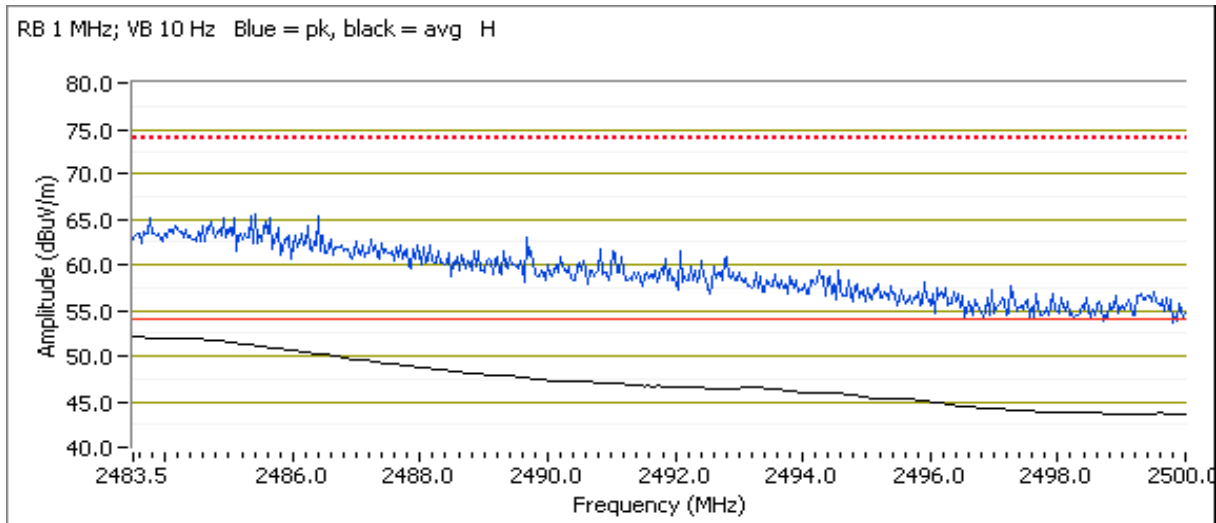



EMC Test Data

Client: Intel Corporation	Job Number: J94914
Model: 7265D2W	T-Log Number: T95471
Contact: Steve Hackett	Project Manager: Christine Krebill
Standard: FCC Part 15.247, 15.407, RSS-210	Project Coordinator: -
	Class: N/A

Channel: 9 Mode: n40
 Tx Chain: A Data Rate: HT0

Power Settings		
Target (dBm)	Measured (dBm)	Software Setting
12.5	12.8	15.5

Band Edge Signal Field Strength - Direct measurement of field strength

Frequency MHz	Level dB μ V/m	Pol v/h	15.209 / 15.247		Detector Pk/QP/Avg	Azimuth degrees	Height meters	Comments
			Limit	Margin				
2483.500	52.3	H	54.0	-1.7	AVG	303	1.2	POS; RB 1 MHz; VB: 10 Hz, Note 3
2484.530	64.9	H	74.0	-9.1	PK	303	1.2	POS; RB 1 MHz; VB: 3 MHz
2483.500	51.5	V	54.0	-2.5	AVG	282	1.2	POS; RB 1 MHz; VB: 10 Hz, Note 3
2484.100	63.4	V	74.0	-10.6	PK	282	1.2	POS; RB 1 MHz; VB: 3 MHz

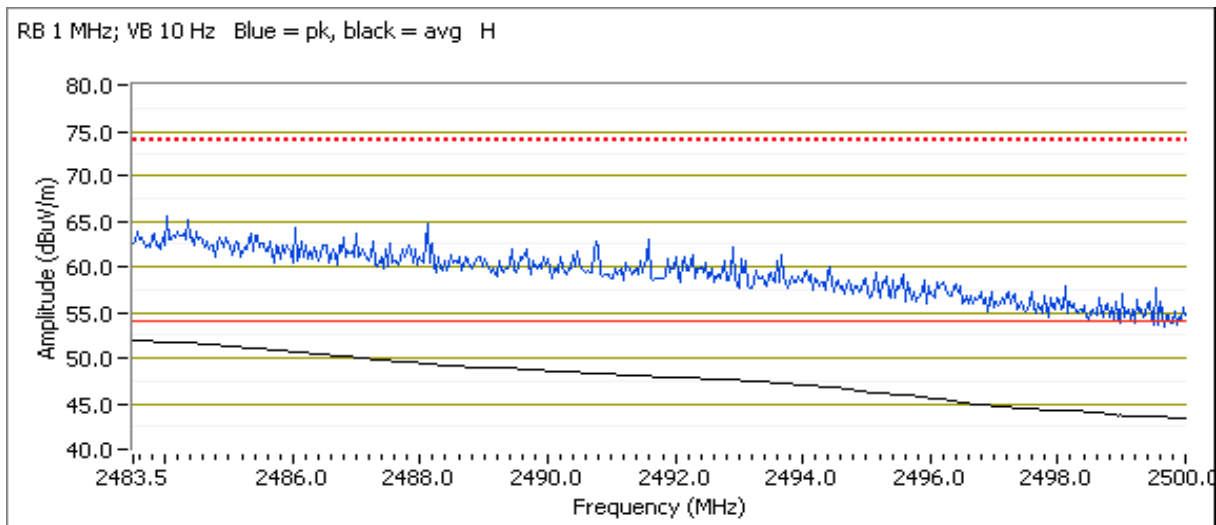



EMC Test Data

Client:	Intel Corporation	Job Number:	J94914
Model:	7265D2W	T-Log Number:	T95471
Contact:	Steve Hackett	Project Manager:	Christine Krebill
Standard:	FCC Part 15.247, 15.407, RSS-210	Project Coordinator:	-
		Class:	N/A

RSS 210 and FCC 15.247 (DTS) Radiated Spurious Emissions

Test Specific Details

Objective: The objective of this test session is to perform final qualification testing of the EUT with respect to the specification listed above.

General Test Configuration

The EUT and all local support equipment were located on the turntable for radiated spurious emissions testing. For radiated emissions testing the measurement antenna was located 3 meters from the EUT, unless otherwise noted.

Ambient Conditions:

Temperature: 25 °C
Rel. Humidity: 30 %

Summary of Results - Device Operating in the 2400-2483.5 MHz Band

Run #	Mode	Channel	Target Power	Power Setting	Test Performed	Limit	Result / Margin
1	b	1 - 2412MHz	16.5	21.5	Restricted Band Edge (2390 MHz)	FCC Part 15.209 / 15.247(c)	47.9 dBµV/m @ 2389.3 MHz (-6.1 dB)
		11 - 2462MHz	16.5	21.0	Restricted Band Edge (2483.5 MHz)		47.1 dBµV/m @ 2488.8 MHz (-6.9 dB)
2	g	1 - 2412MHz	14.5	24.0	Restricted Band Edge (2390 MHz)		48.0 dBµV/m @ 2390.0 MHz (-6.0 dB)
		2 - 2417MHz	15.5	25.0			47.8 dBµV/m @ 2390.0 MHz (-6.2 dB)
		10 - 2457MHz	15.5	25.0	Restricted Band Edge (2483.5 MHz)	46.2 dBµV/m @ 2483.5 MHz (-7.8 dB)	
		11 - 2462MHz	12.5	21.5		46.1 dBµV/m @ 2483.5 MHz (-7.9 dB)	



EMC Test Data

Client:	Intel Corporation	Job Number:	J94914
Model:	7265D2W	T-Log Number:	T95471
Contact:	Steve Hackett	Project Manager:	Christine Krebill
Standard:	FCC Part 15.247, 15.407, RSS-210	Project Coordinator:	-
		Class:	N/A

Test Case	Channel	Start (MHz)	Stop (MHz)	Bandwidth (MHz)	Measurement	Limit	Result
3	n20	1 - 2412MHz	14.5	24.0	Restricted Band Edge (2390 MHz)	FCC Part 15.209 / 15.247(c)	49.6 dBµV/m @ 2390.0 MHz (-4.4 dB)
		2 - 2417MHz	15.5	25.0			47.6 dBµV/m @ 2390.0 MHz (-6.4 dB)
		10 - 2457MHz	15.5	25.5	Restricted Band Edge (2483.5 MHz)		47.2 dBµV/m @ 2483.6 MHz (-6.8 dB)
		11 - 2462MHz	12.5	22.0	46.7 dBµV/m @ 2483.5 MHz (-7.3 dB)		
4	n40	3 - 2422MHz	13.5	21.5	Restricted Band Edge (2390 MHz)	FCC Part 15.209 / 15.247(c)	53.0 dBµV/m @ 2390.0 MHz (-1.0 dB)
		4 - 2427MHz	14.5	22.5			53.5 dBµV/m @ 2390.0 MHz (-0.5 dB)
		6 - 2437MHz	16.5	25.0	Restricted Band Edge (2483.5 MHz)		53.4 dBµV/m @ 2483.5 MHz (-0.6 dB)
		7 - 2442MHz	13.5	23.0			51.4 dBµV/m @ 2483.5 MHz (-2.6 dB)
		8 - 2447MHz	12.5	22.0			51.8 dBµV/m @ 2483.5 MHz (-2.2 dB)
		9 - 2452MHz	11.5	20.5			49.8 dBµV/m @ 2483.5 MHz (-4.2 dB)

Modifications Made During Testing

No modifications were made to the EUT during testing

Deviations From The Standard

No deviations were made from the requirements of the standard.

Sample Notes

MAC Address: 001500F15B5D DRTU Tool Version 1.7.3-935 Driver version 17.1.0.11

Antenna: Skycross WiMax/WLAN



EMC Test Data

Client:	Intel Corporation	Job Number:	J94914
Model:	7265D2W	T-Log Number:	T95471
		Project Manager:	Christine Krebill
Contact:	Steve Hackett	Project Coordinator:	-
Standard:	FCC Part 15.247, 15.407, RSS-210	Class:	N/A

Procedure Comments:

Measurements performed in accordance with FCC KDB 558074

Peak measurements performed with: RBW=1MHz, VBW=3MHz, peak detector, max hold, auto sweep time

Unless otherwise stated/noted, emission has duty cycle $\geq 98\%$ and was measured using RBW=1MHz, VBW=10Hz, peak detector, linear average mode, auto sweep time, max hold.

Mode	Data Rate	Duty Cycle (x)	Constant DC?	T (ms)	Pwr Cor Factor*	Lin Volt Cor Factor**	Min VBW for FS (Hz)
11b	1	0.99	Yes	2.272	0.0	0.0	440
11g	6	0.99	Yes	2.06	0.0	0.0	485
n20	HT0	0.99	Yes	1.919	0.0	0.0	521
n40	HT0	0.97	Yes	0.944	0.1	0.2	1059

Measurement Specific Notes:

Note 3:	Emission has duty cycle $< 98\%$, but constant, average measurement performed: RBW=1MHz, VBW=10Hz, peak detector, linear averaging, auto sweep, trace average 100 traces, measurement corrected by Linear Voltage correction factor
Note 6:	Plots of the average bandedge do not account for any duty cycle correction. Refer to the tabular results for final measurements.



EMC Test Data

Client: Intel Corporation	Job Number: J94914
Model: 7265D2W	T-Log Number: T95471
Contact: Steve Hackett	Project Manager: Christine Krebill
Standard: FCC Part 15.247, 15.407, RSS-210	Project Coordinator: -
	Class: N/A

Run #1: Radiated Bandedge Measurements

Date of Test: 6/6/2014 0:00
 Test Engineer: Joseph Cadigal
 Test Location: FT Chamber#7
 Config. Used: 1
 Config Change: none
 EUT Voltage: 3.3 VDC

Channel: 1 Mode: b
 Tx Chain: B Data Rate: 1

Power Settings		
Target (dBm)	Measured (dBm)	Software Setting
16.5	16.6	21.5

Band Edge Signal Field Strength - Direct measurement of field strength

Frequency	Level	Pol	15.209 / 15.247		Detector	Azimuth	Height	Comments
MHz	dB μ V/m	v/h	Limit	Margin	Pk/QP/Avg	degrees	meters	
2389.280	47.9	H	54.0	-6.1	AVG	172	1.2	POS; RB 1 MHz; VB: 10 Hz
2389.840	54.0	H	74.0	-20.0	PK	172	1.2	POS; RB 1 MHz; VB: 3 MHz
2389.360	44.9	V	54.0	-9.1	AVG	14	1.1	POS; RB 1 MHz; VB: 10 Hz
2371.160	53.3	V	74.0	-20.7	PK	14	1.1	POS; RB 1 MHz; VB: 3 MHz

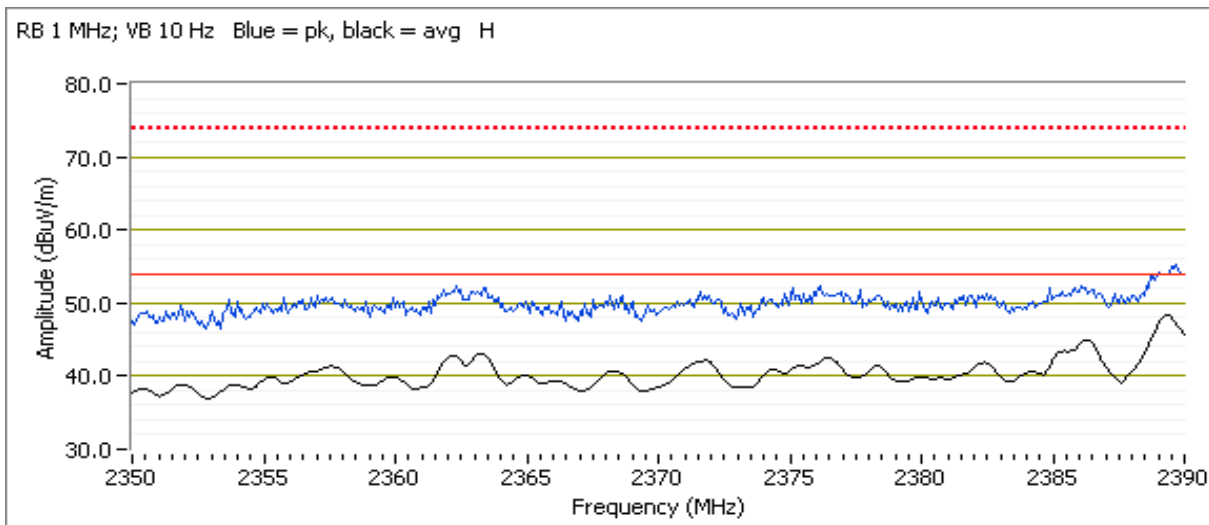



EMC Test Data

Client: Intel Corporation	Job Number: J94914
Model: 7265D2W	T-Log Number: T95471
Contact: Steve Hackett	Project Manager: Christine Krebill
Standard: FCC Part 15.247, 15.407, RSS-210	Project Coordinator: -
	Class: N/A

Channel: 11 Mode: b
 Tx Chain: B Data Rate: 1

Power Settings		
Target (dBm)	Measured (dBm)	Software Setting
16.5	16.6	21.0

Band Edge Signal Field Strength - Direct measurement of field strength

Frequency MHz	Level dB μ V/m	Pol v/h	15.209 / 15.247		Detector Pk/QP/Avg	Azimuth degrees	Height meters	Comments
			Limit	Margin				
2488.790	47.1	H	54.0	-6.9	AVG	172	1.1	POS; RB 1 MHz; VB: 10 Hz
2488.430	55.0	H	74.0	-19.0	PK	172	1.1	POS; RB 1 MHz; VB: 3 MHz
2488.790	43.2	V	54.0	-10.8	AVG	20	1.0	POS; RB 1 MHz; VB: 10 Hz
2496.990	52.8	V	74.0	-21.2	PK	20	1.0	POS; RB 1 MHz; VB: 3 MHz

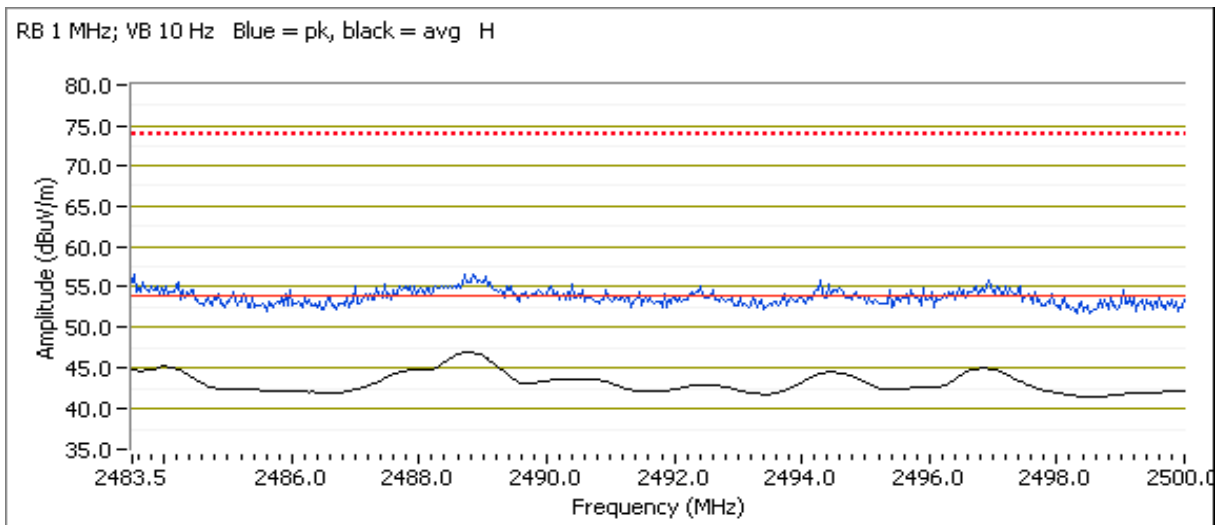



EMC Test Data

Client: Intel Corporation	Job Number: J94914
Model: 7265D2W	T-Log Number: T95471
Contact: Steve Hackett	Project Manager: Christine Krebill
Standard: FCC Part 15.247, 15.407, RSS-210	Project Coordinator: -
	Class: N/A

Run #2: Radiated Bandedge Measurements

Date of Test: 6/9/2014 0:00
 Test Engineer: John Caizzi
 Test Location: Chamber 7

Config. Used: 1
 Config Change: none
 EUT Voltage: 3.3 VDC

Channel: 1 Mode: g
 Tx Chain: B Data Rate: 6

Power Settings		
Target (dBm)	Measured (dBm)	Software Setting
14.5	14.6	24.0

Band Edge Signal Field Strength - Direct measurement of field strength

Frequency MHz	Level dB μ V/m	Pol v/h	15.209 / 15.247		Detector Pk/QP/Avg	Azimuth degrees	Height meters	Comments
			Limit	Margin				
2390.000	48.0	H	54.0	-6.0	AVG	166	1.10	POS; RB 1 MHz; VB: 10 Hz
2389.600	62.4	H	74.0	-11.6	PK	166	1.10	POS; RB 1 MHz; VB: 3 MHz
2390.000	44.8	V	54.0	-9.2	AVG	84	1.00	POS; RB 1 MHz; VB: 10 Hz
2389.760	57.7	V	74.0	-16.3	PK	84	1.00	POS; RB 1 MHz; VB: 3 MHz

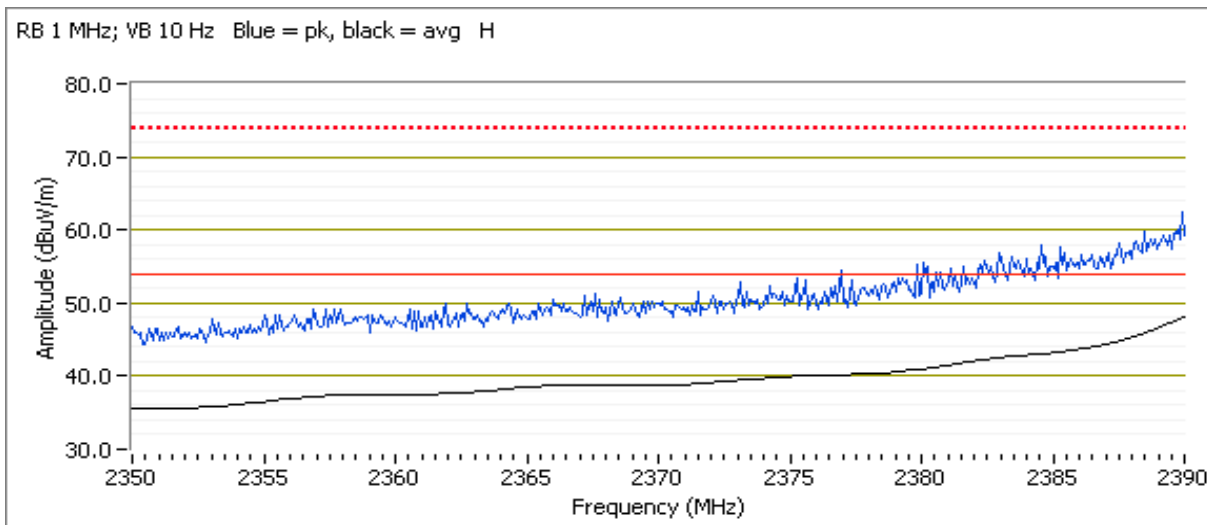



EMC Test Data

Client:	Intel Corporation	Job Number:	J94914
Model:	7265D2W	T-Log Number:	T95471
Contact:	Steve Hackett	Project Manager:	Christine Krebill
Standard:	FCC Part 15.247, 15.407, RSS-210	Project Coordinator:	-
		Class:	N/A

Channel: 2 Mode: g
 Tx Chain: B Data Rate: 6

Power Settings		
Target (dBm)	Measured (dBm)	Software Setting
15.5	15.7	25.0

Band Edge Signal Field Strength - Direct measurement of field strength

Frequency	Level	Pol	15.209 / 15.247		Detector	Azimuth	Height	Comments
MHz	dB μ V/m	v/h	Limit	Margin	Pk/QP/Avg	degrees	meters	
2390.000	47.8	H	54.0	-6.2	AVG	193	1.00	POS; RB 1 MHz; VB: 10 Hz
2385.670	64.7	H	74.0	-9.3	PK	193	1.00	POS; RB 1 MHz; VB: 3 MHz

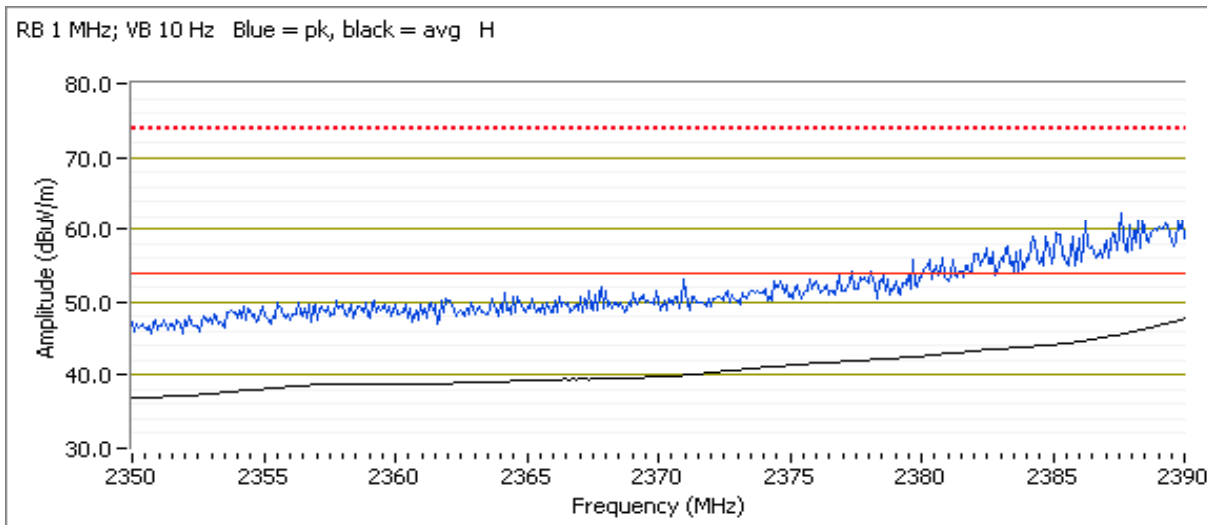



EMC Test Data

Client:	Intel Corporation	Job Number:	J94914
Model:	7265D2W	T-Log Number:	T95471
Contact:	Steve Hackett	Project Manager:	Christine Krebill
Standard:	FCC Part 15.247, 15.407, RSS-210	Project Coordinator:	-
		Class:	N/A

Channel: 10 Mode: g
 Tx Chain: B Data Rate: 6

Power Settings		
Target (dBm)	Measured (dBm)	Software Setting
15.5	15.5	25.0

Band Edge Signal Field Strength - Direct measurement of field strength

Frequency	Level	Pol	15.209 / 15.247		Detector	Azimuth	Height	Comments
MHz	dB μ V/m	v/h	Limit	Margin	Pk/QP/Avg	degrees	meters	
2483.530	46.2	H	54.0	-7.8	AVG	170	1.11	POS; RB 1 MHz; VB: 10 Hz
2484.950	61.6	H	74.0	-12.4	PK	170	1.11	POS; RB 1 MHz; VB: 3 MHz

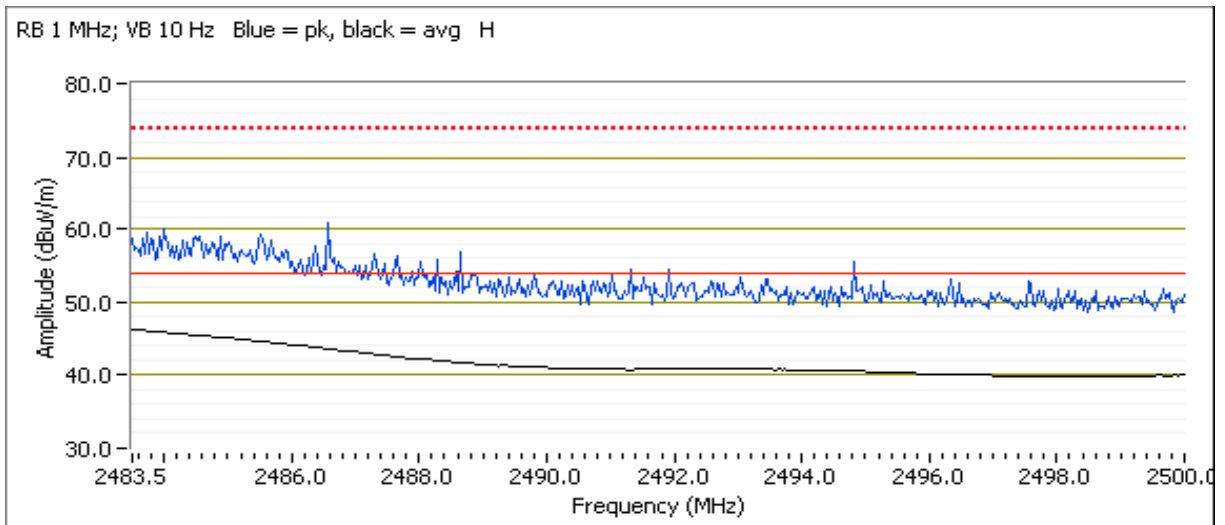



EMC Test Data

Client:	Intel Corporation	Job Number:	J94914
Model:	7265D2W	T-Log Number:	T95471
Contact:	Steve Hackett	Project Manager:	Christine Krebill
Standard:	FCC Part 15.247, 15.407, RSS-210	Project Coordinator:	-
		Class:	N/A

Channel: 11 Mode: g
 Tx Chain: B Data Rate: 6

Power Settings		
Target (dBm)	Measured (dBm)	Software Setting
12.5	12.4	21.5

Band Edge Signal Field Strength - Direct measurement of field strength

Frequency	Level	Pol	15.209 / 15.247		Detector	Azimuth	Height	Comments
MHz	dB μ V/m	v/h	Limit	Margin	Pk/QP/Avg	degrees	meters	
2483.500	46.1	H	54.0	-7.9	AVG	164	1.10	POS; RB 1 MHz; VB: 10 Hz
2484.760	61.2	H	74.0	-12.8	PK	164	1.10	POS; RB 1 MHz; VB: 3 MHz

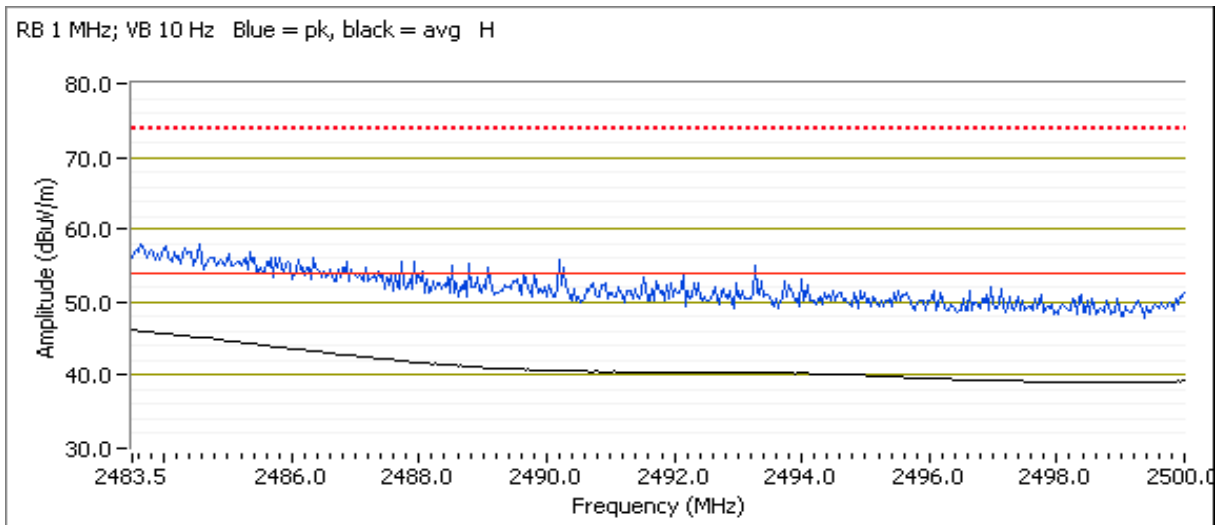



EMC Test Data

Client: Intel Corporation	Job Number: J94914
Model: 7265D2W	T-Log Number: T95471
Contact: Steve Hackett	Project Manager: Christine Krebill
Standard: FCC Part 15.247, 15.407, RSS-210	Project Coordinator: -
	Class: N/A

Run #3: Radiated Bandedge Measurements

Date of Test: 6/9/2014 0:00
 Test Engineer: John Caizzi
 Test Location: Chamber 7

Config. Used: 1
 Config Change: none
 EUT Voltage: 3.3 VDC

Channel: 1 Mode: n20
 Tx Chain: B Data Rate: HT0

Power Settings		
Target (dBm)	Measured (dBm)	Software Setting
14.5	14.8	24.0

Band Edge Signal Field Strength - Direct measurement of field strength

Frequency MHz	Level dB μ V/m	Pol v/h	15.209 / 15.247		Detector Pk/QP/Avg	Azimuth degrees	Height meters	Comments
			Limit	Margin				
2390.000	49.6	H	54.0	-4.4	AVG	162	1.14	POS; RB 1 MHz; VB: 10 Hz
2389.120	63.2	H	74.0	-10.8	PK	162	1.14	POS; RB 1 MHz; VB: 3 MHz
2390.000	48.6	V	54.0	-5.4	AVG	98	1.11	POS; RB 1 MHz; VB: 10 Hz
2388.320	63.4	V	74.0	-10.6	PK	98	1.11	POS; RB 1 MHz; VB: 3 MHz

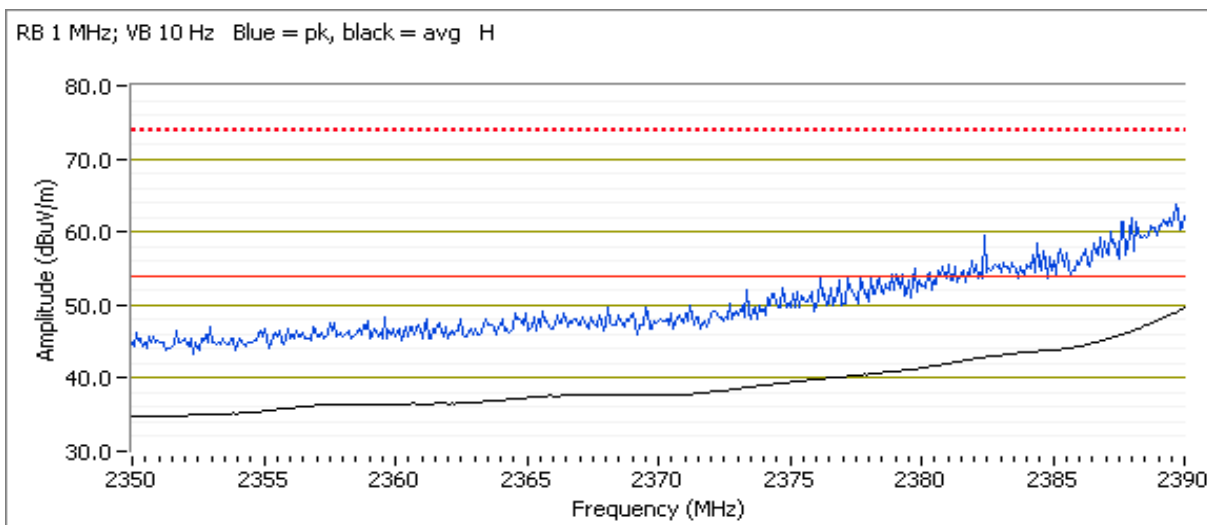



EMC Test Data

Client: Intel Corporation	Job Number: J94914
Model: 7265D2W	T-Log Number: T95471
Contact: Steve Hackett	Project Manager: Christine Krebill
Standard: FCC Part 15.247, 15.407, RSS-210	Project Coordinator: -
	Class: N/A

Channel: 2 Mode: n20
 Tx Chain: B Data Rate: HT0

Power Settings		
Target (dBm)	Measured (dBm)	Software Setting
15.5	15.6	25.0

Band Edge Signal Field Strength - Direct measurement of field strength

Frequency MHz	Level dB μ V/m	Pol v/h	15.209 / 15.247		Detector Pk/QP/Avg	Azimuth degrees	Height meters	Comments
			Limit	Margin				
2390.000	47.6	H	54.0	-6.4	AVG	161	1.11	POS; RB 1 MHz; VB: 10 Hz
2389.760	62.0	H	74.0	-12.0	PK	161	1.11	POS; RB 1 MHz; VB: 3 MHz
2390.000	45.9	V	54.0	-8.1	AVG	98	1.09	POS; RB 1 MHz; VB: 10 Hz
2388.080	61.1	V	74.0	-12.9	PK	98	1.09	POS; RB 1 MHz; VB: 3 MHz

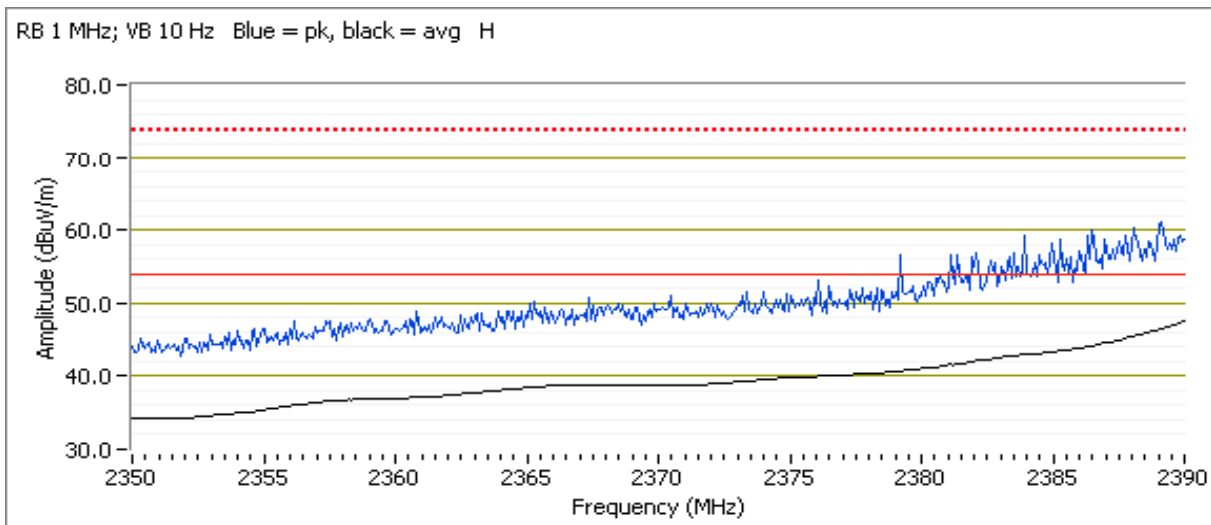



EMC Test Data

Client:	Intel Corporation	Job Number:	J94914
Model:	7265D2W	T-Log Number:	T95471
Contact:	Steve Hackett	Project Manager:	Christine Krebill
Standard:	FCC Part 15.247, 15.407, RSS-210	Project Coordinator:	-
		Class:	N/A

Channel: 10 Mode: n20
 Tx Chain: B Data Rate: HT0

Power Settings		
Target (dBm)	Measured (dBm)	Software Setting
15.5	15.7	25.5

Band Edge Signal Field Strength - Direct measurement of field strength

Frequency	Level	Pol	15.209 / 15.247		Detector	Azimuth	Height	Comments
MHz	dB μ V/m	v/h	Limit	Margin	Pk/QP/Avg	degrees	meters	
2483.570	47.2	H	54.0	-6.8	AVG	167	1.10	POS; RB 1 MHz; VB: 10 Hz
2486.510	60.3	H	74.0	-13.7	PK	167	1.10	POS; RB 1 MHz; VB: 3 MHz

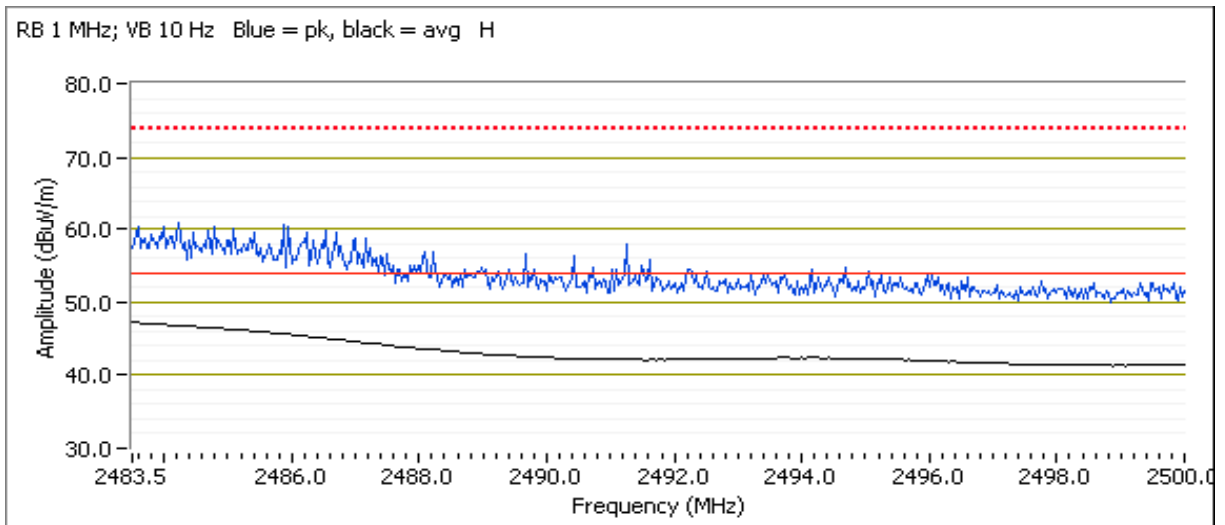



EMC Test Data

Client:	Intel Corporation	Job Number:	J94914
Model:	7265D2W	T-Log Number:	T95471
Contact:	Steve Hackett	Project Manager:	Christine Krebill
Standard:	FCC Part 15.247, 15.407, RSS-210	Project Coordinator:	-
		Class:	N/A

Channel: 11 Mode: n20
 Tx Chain: B Data Rate: HT0

Power Settings		
Target (dBm)	Measured (dBm)	Software Setting
12.5	12.8	22.0

Band Edge Signal Field Strength - Direct measurement of field strength

Frequency	Level	Pol	15.209 / 15.247		Detector	Azimuth	Height	Comments
MHz	dB μ V/m	v/h	Limit	Margin	Pk/QP/Avg	degrees	meters	
2483.500	46.7	H	54.0	-7.3	AVG	162	1.10	POS; RB 1 MHz; VB: 10 Hz
2484.000	61.0	H	74.0	-13.0	PK	162	1.10	POS; RB 1 MHz; VB: 3 MHz

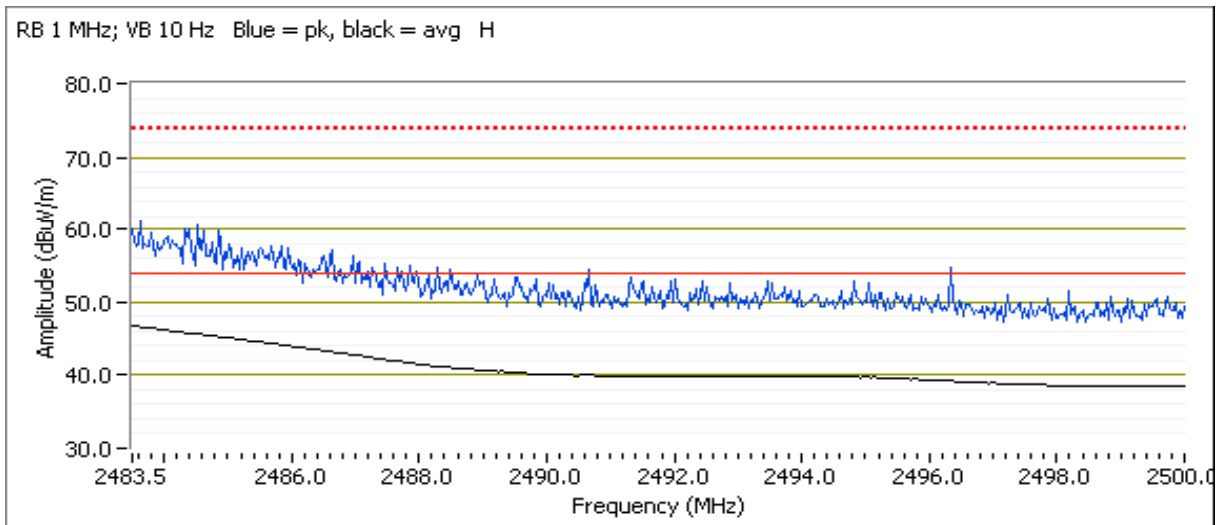



EMC Test Data

Client: Intel Corporation	Job Number: J94914
Model: 7265D2W	T-Log Number: T95471
Contact: Steve Hackett	Project Manager: Christine Krebill
Standard: FCC Part 15.247, 15.407, RSS-210	Project Coordinator: -
	Class: N/A

Run #4: Radiated Bandedge Measurements

Date of Test: 6/9/2014 0:00
 Test Engineer: John Caizzi
 Test Location: Chamber 7

Config. Used: 1
 Config Change: none
 EUT Voltage: 3.3 VDC

Channel: 3 Mode: n40
 Tx Chain: B Data Rate: HT0

Power Settings		
Target (dBm)	Measured (dBm)	Software Setting
13.5	13.5	21.5

Band Edge Signal Field Strength - Direct measurement of field strength

Frequency MHz	Level dB μ V/m	Pol v/h	15.209 / 15.247		Detector Pk/QP/Avg	Azimuth degrees	Height meters	Comments
			Limit	Margin				
2390.000	53.0	V	54.0	-1.0	AVG	98	1.09	POS; RB 1 MHz; VB: 10 Hz, Note 3
2389.760	66.5	V	74.0	-7.5	PK	98	1.09	POS; RB 1 MHz; VB: 3 MHz
2390.000	52.6	H	54.0	-1.4	AVG	165	1.14	POS; RB 1 MHz; VB: 10 Hz, Note 3
2388.400	65.0	H	74.0	-9.0	PK	165	1.14	POS; RB 1 MHz; VB: 3 MHz

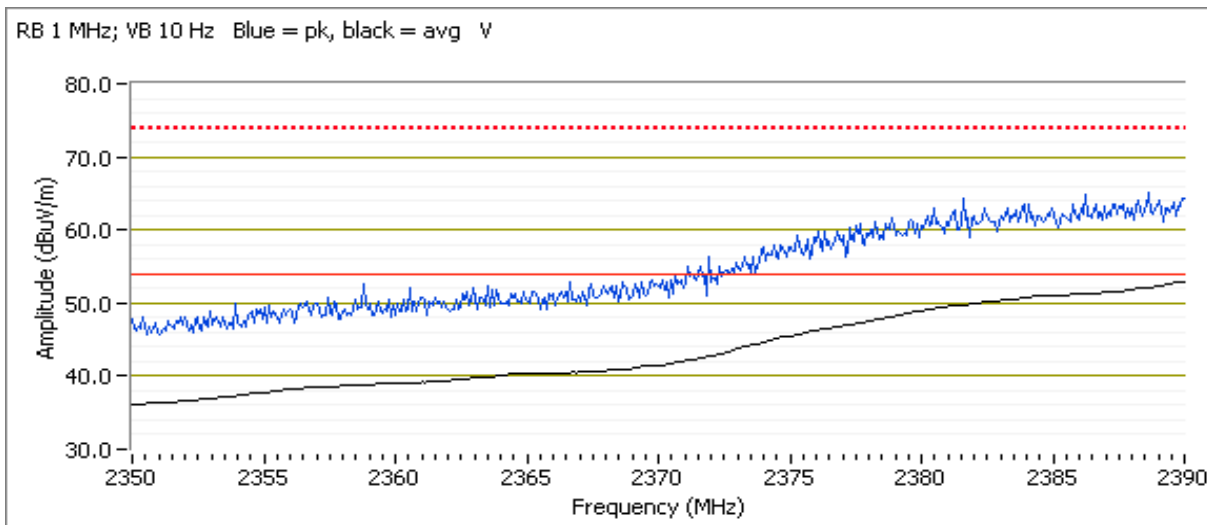



EMC Test Data

Client:	Intel Corporation	Job Number:	J94914
Model:	7265D2W	T-Log Number:	T95471
Contact:	Steve Hackett	Project Manager:	Christine Krebill
Standard:	FCC Part 15.247, 15.407, RSS-210	Project Coordinator:	-
		Class:	N/A

Channel: 4 Mode: n40
 Tx Chain: B Data Rate: HT0

Power Settings		
Target (dBm)	Measured (dBm)	Software Setting
14.5	-	22.5

Band Edge Signal Field Strength - Direct measurement of field strength

Frequency	Level	Pol	15.209 / 15.247		Detector	Azimuth	Height	Comments
MHz	dB μ V/m	v/h	Limit	Margin	Pk/QP/Avg	degrees	meters	
2390.000	53.5	H	54.0	-0.5	AVG	166	1.13	POS; RB 1 MHz; VB: 10 Hz, Note 3
2389.600	66.7	H	74.0	-7.3	PK	166	1.13	POS; RB 1 MHz; VB: 3 MHz

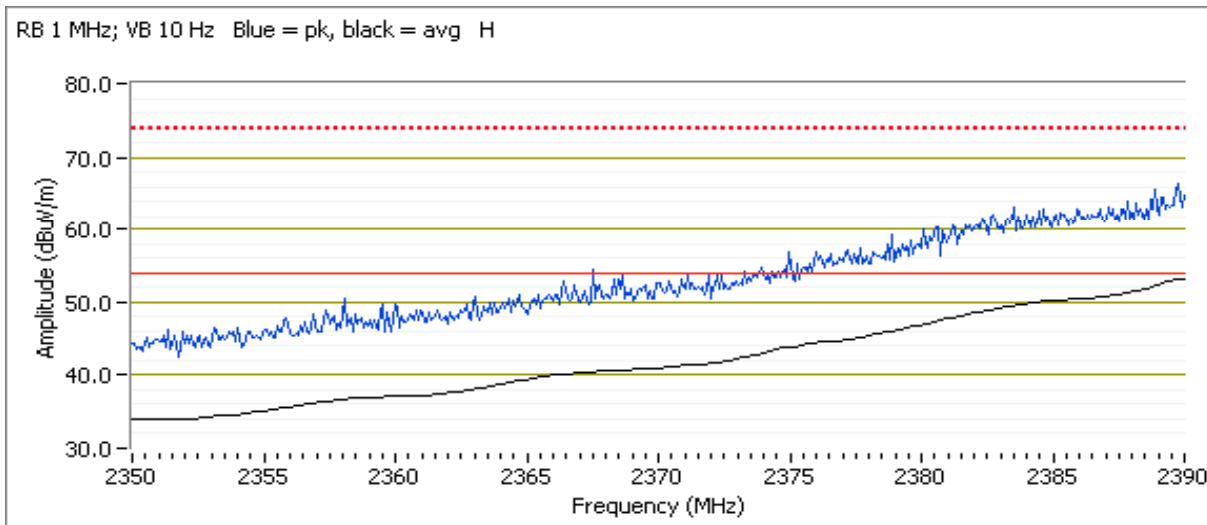



EMC Test Data

Client: Intel Corporation	Job Number: J94914
Model: 7265D2W	T-Log Number: T95471
Contact: Steve Hackett	Project Manager: Christine Krebill
Standard: FCC Part 15.247, 15.407, RSS-210	Project Coordinator: -
	Class: N/A

Date of Test: 6/9/2014 0:00
 Test Engineer: Jack Liu
 Test Location: Chamber 7

Config. Used: 1
 Config Change: none
 EUT Voltage: 3.3 VDC

Channel: 6 Mode: n40
 Tx Chain: B Data Rate: HT0

Power Settings		
Target (dBm)	Measured (dBm)	Software Setting
16.5	15.2	25.0

Band Edge Signal Field Strength - Direct measurement of field strength

Frequency	Level	Pol	15.209 / 15.247		Detector	Azimuth	Height	Comments
MHz	dB μ V/m	v/h	Limit	Margin	Pk/QP/Avg	degrees	meters	
2483.500	53.4	H	54.0	-0.6	AVG	171	1.1	POS; RB 1 MHz; VB: 10 Hz, Note 3
2483.960	67.9	H	74.0	-6.1	PK	171	1.1	POS; RB 1 MHz; VB: 3 MHz

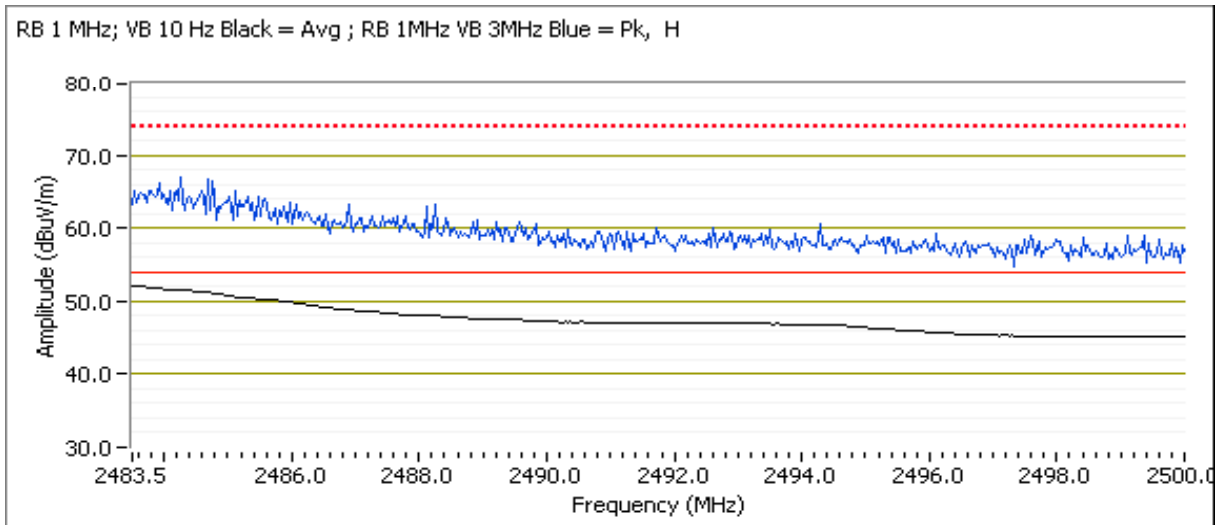



EMC Test Data

Client: Intel Corporation	Job Number: J94914
Model: 7265D2W	T-Log Number: T95471
Contact: Steve Hackett	Project Manager: Christine Krebill
Standard: FCC Part 15.247, 15.407, RSS-210	Project Coordinator: -
	Class: N/A

Date of Test: 6/9/2014 0:00
 Test Engineer: John Caizzi
 Test Location: Chamber 7

Config. Used: 1
 Config Change: none
 EUT Voltage: 3.3 VDC

Channel: 7 Mode: n40
 Tx Chain: B Data Rate: HT0

Power Settings		
Target (dBm)	Measured (dBm)	Software Setting
13.5	13.7	23.0

Band Edge Signal Field Strength - Direct measurement of field strength

Frequency MHz	Level dB μ V/m	Pol v/h	15.209 / 15.247		Detector Pk/QP/Avg	Azimuth degrees	Height meters	Comments
			Limit	Margin				
2483.500	51.4	H	54.0	-2.6	AVG	170	1.12	POS; RB 1 MHz; VB: 10 Hz, Note 3
2484.920	64.6	H	74.0	-9.4	PK	170	1.12	POS; RB 1 MHz; VB: 3 MHz
2483.530	48.0	V	54.0	-6.0	AVG	76	1.00	POS; RB 1 MHz; VB: 10 Hz, Note 3
2484.290	60.8	V	74.0	-13.2	PK	76	1.00	POS; RB 1 MHz; VB: 3 MHz

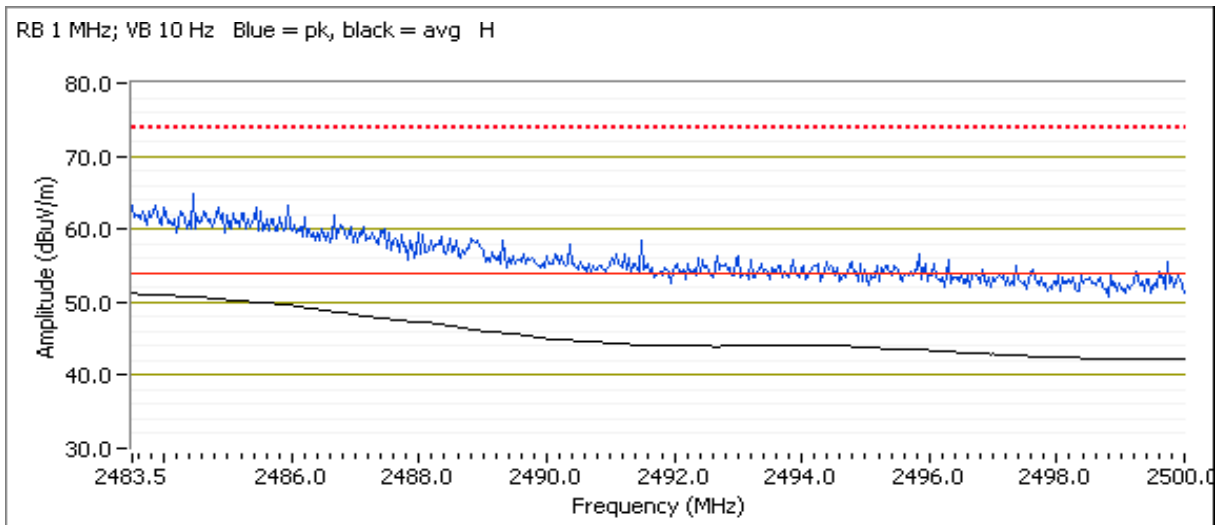



EMC Test Data

Client:	Intel Corporation	Job Number:	J94914
Model:	7265D2W	T-Log Number:	T95471
Contact:	Steve Hackett	Project Manager:	Christine Krebill
Standard:	FCC Part 15.247, 15.407, RSS-210	Project Coordinator:	-
		Class:	N/A

Date of Test: 6/9/2014 0:00
 Test Engineer: Jack Liu
 Test Location: Chamber 7

Config. Used: 1
 Config Change: none
 EUT Voltage: 3.3 VDC

Channel: 8 Mode: n40
 Tx Chain: B Data Rate: HT0

Power Settings		
Target (dBm)	Measured (dBm)	Software Setting
12.5	12.7	22.0

Band Edge Signal Field Strength - Direct measurement of field strength

Frequency MHz	Level dB μ V/m	Pol v/h	15.209 / 15.247		Detector Pk/QP/Avg	Azimuth degrees	Height meters	Comments
			Limit	Margin				
2483.500	51.8	H	54.0	-2.2	AVG	176	1.1	POS; RB 1 MHz; VB: 10 Hz, Note 3
2484.720	65.3	H	74.0	-8.7	PK	176	1.1	POS; RB 1 MHz; VB: 3 MHz
2483.570	46.9	V	54.0	-7.1	AVG	74	1.8	POS; RB 1 MHz; VB: 10 Hz, Note 3
2485.420	59.5	V	74.0	-14.5	PK	74	1.8	POS; RB 1 MHz; VB: 3 MHz

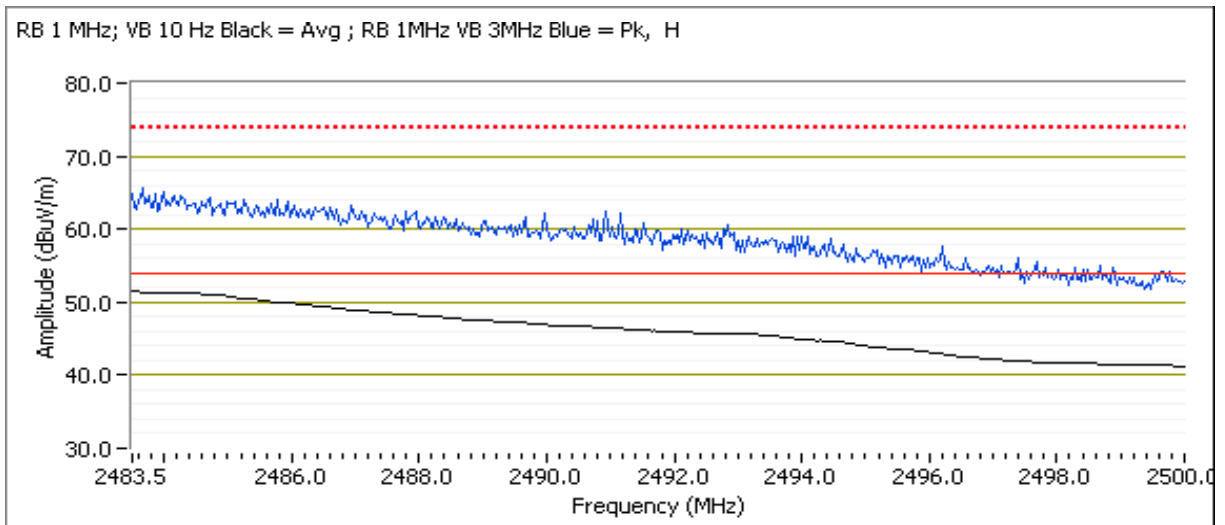



EMC Test Data

Client:	Intel Corporation	Job Number:	J94914
Model:	7265D2W	T-Log Number:	T95471
Contact:	Steve Hackett	Project Manager:	Christine Krebill
Standard:	FCC Part 15.247, 15.407, RSS-210	Project Coordinator:	-
		Class:	N/A

Channel: 9 Mode: n40
 Tx Chain: B Data Rate: HT0

Power Settings		
Target (dBm)	Measured (dBm)	Software Setting
11.5	11.4	20.5

Band Edge Signal Field Strength - Direct measurement of field strength

Frequency MHz	Level dB μ V/m	Pol v/h	15.209 / 15.247		Detector Pk/QP/Avg	Azimuth degrees	Height meters	Comments
			Limit	Margin				
2483.500	49.8	H	54.0	-4.2	AVG	179	1.0	POS; RB 1 MHz; VB: 10 Hz, Note 3
2484.130	61.7	H	74.0	-12.3	PK	179	1.0	POS; RB 1 MHz; VB: 3 MHz
2483.500	47.0	V	54.0	-7.0	AVG	62	1.0	POS; RB 1 MHz; VB: 10 Hz, Note 3
2484.360	59.7	V	74.0	-14.3	PK	62	1.0	POS; RB 1 MHz; VB: 3 MHz

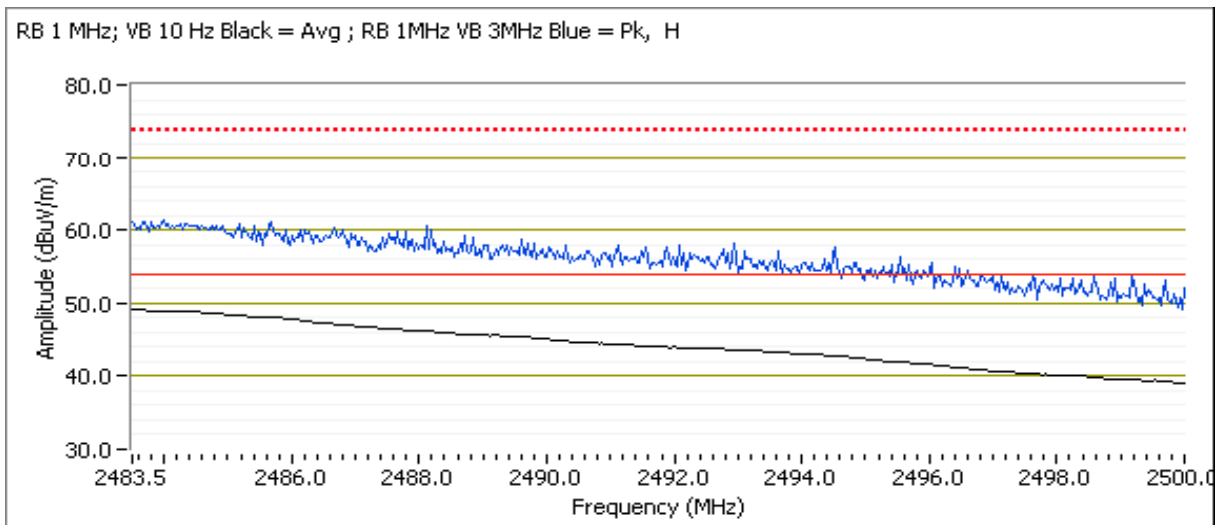



EMC Test Data

Client:	Intel Corporation	Job Number:	J94914
Model:	7265D2W	T-Log Number:	T95471
		Project Manager:	Christine Krebill
Contact:	Steve Hackett	Project Coordinator:	-
Standard:	FCC Part 15.247, 15.407, RSS-210	Class:	N/A

RSS 210 and FCC 15.247 (DTS) Radiated Spurious Emissions

Test Specific Details

Objective: The objective of this test session is to perform final qualification testing of the EUT with respect to the specification listed above.

General Test Configuration

The EUT and all local support equipment were located on the turntable for radiated spurious emissions testing. For radiated emissions testing the measurement antenna was located 3 meters from the EUT, unless otherwise noted.

Ambient Conditions:

Temperature: 24 °C
Rel. Humidity: 35 %



EMC Test Data

Client:	Intel Corporation	Job Number:	J94914
Model:	7265D2W	T-Log Number:	T95471
Contact:	Steve Hackett	Project Manager:	Christine Krebill
Standard:	FCC Part 15.247, 15.407, RSS-210	Project Coordinator:	-
		Class:	N/A

Summary of Results - Device Operating in the 2400-2483.5 MHz Band

Run #	Mode	Channel	Target Power	Power Setting	Test Performed	Limit	Result / Margin
1	n20	1 - 2412MHz	12.0, 12.0	16.0 21.5	Restricted Band Edge (2390 MHz)	FCC Part 15.209 / 15.247(c)	50.7 dBµV/m @ 2389.9 MHz (-3.3 dB)
		2 - 2417MHz	13.5, 13.5	17.0 22.5			49.4 dBµV/m @ 2390.0 MHz (-4.6 dB)
		3 - 2422MHz	17.5, 17.5	23.0 28.0			52.8 dBµV/m @ 2389.7 MHz (-1.2 dB)
		9 - 2452MHz	17.5, 17.5	21.5 27.0	Restricted Band Edge (2483.5 MHz)		52.9 dBµV/m @ 2483.5 MHz (-1.1 dB)
		10 - 2457MHz	13.5, 13.5	16.0 21.5			49.2 dBµV/m @ 2483.6 MHz (-4.8 dB)
		11 - 2462MHz	12.0, 12.0	16.5 21.0			52.8 dBµV/m @ 2483.5 MHz (-1.2 dB)
2	n40	3 - 2422MHz	9.5, 9.5	14.0 19.5	Restricted Band Edge (2390 MHz)	FCC Part 15.209 / 15.247(c)	47.4 dBµV/m @ 2389.9 MHz (-6.6 dB)
		4 - 2427MHz -	11.5, 11.5	15.5 21.0			49.1 dBµV/m @ 2389.4 MHz (-4.9 dB)
		7 - 2442MHz	11.5, 11.5	9.5 20.0	Restricted Band Edge (2483.5 MHz)		52.2 dBµV/m @ 2483.5 MHz (-1.8 dB)
		8 - 2447MHz	10.5, 10.5	15.0 21.0			52.9 dBµV/m @ 2483.5 MHz (-1.1 dB)
		9 - 2452MHz	9.5, 9.5	13.5 19.5			53.0 dBµV/m @ 2483.5 MHz (-1.0 dB)



EMC Test Data

Client:	Intel Corporation	Job Number:	J94914
Model:	7265D2W	T-Log Number:	T95471
Contact:	Steve Hackett	Project Manager:	Christine Krebill
Standard:	FCC Part 15.247, 15.407, RSS-210	Project Coordinator:	-
		Class:	N/A

Modifications Made During Testing

No modifications were made to the EUT during testing

Deviations From The Standard

No deviations were made from the requirements of the standard.

Sample Notes

MAC Address: 001500F15B5D DRTU Tool Version 1.7.3-935 Driver version 17.1.0.11

Antenna: Skycross WiMax/WLAN

Procedure Comments:

Measurements performed in accordance with FCC KDB 558074

Peak measurements performed with: RBW=1MHz, VBW=3MHz, peak detector, max hold, auto sweep time

Unless otherwise stated/noted, emission has duty cycle $\geq 98\%$ and was measured using RBW=1MHz, VBW=10Hz, peak detector, linear average mode, auto sweep time, max hold.

Mode	Data Rate	Duty Cycle (x)	Constant DC?	T (ms)	Pwr Cor Factor*	Lin Volt Cor Factor**	Min VBW for FS (Hz)
n20	HT0	0.99	Yes	1.919	0.0	0.0	521
n40	HT0	0.97	Yes	0.944	0.1	0.2	1059

Measurement Specific Notes:

Note 1:	Emission has duty cycle $< 98\%$, but constant, average measurement performed: RBW=1MHz, VBW=10Hz, peak detector, linear averaging, auto sweep, trace average 100 traces, measurement corrected by Linear Voltage correction factor
Note 2:	Plots of the average bandedge do not account for any duty cycle correction. Refer to the tabular results for final measurements.



EMC Test Data

Client: Intel Corporation	Job Number: J94914
Model: 7265D2W	T-Log Number: T95471
Contact: Steve Hackett	Project Manager: Christine Krebill
Standard: FCC Part 15.247, 15.407, RSS-210	Project Coordinator: -
	Class: N/A

Run #1: Radiated Bandedge Measurements

Date of Test: 6/10/2014 0:00
 Test Engineer: John Caizzi
 Test Location: Chamber 7

Config. Used: 1
 Config Change: none
 EUT Voltage: 3.3 VDC

Channel: 1 Mode: n20
 Tx Chain: Both Data Rate: HT0

Chain	Power Settings								Software Setting
	Target (dBm)				Measured (dBm)				
	A	B	C	Total	A	B	C	Total	
	12.0	12.0		15.0	12.0	12.2		15.1	16.0, 21.5

Band Edge Signal Field Strength - Direct measurement of field strength

Frequency	Level	Pol	15.209 / 15.247		Detector	Azimuth	Height	Comments
MHz	dB μ V/m	v/h	Limit	Margin	Pk/QP/Avg	degrees	meters	
2389.920	50.7	H	54.0	-3.3	AVG	71	1.27	POS; RB 1 MHz; VB: 10 Hz
2388.160	64.0	H	74.0	-10.0	PK	71	1.27	POS; RB 1 MHz; VB: 3 MHz
2390.000	45.9	V	54.0	-8.1	AVG	212	2.41	POS; RB 1 MHz; VB: 10 Hz
2384.150	59.2	V	74.0	-14.8	PK	212	2.41	POS; RB 1 MHz; VB: 3 MHz

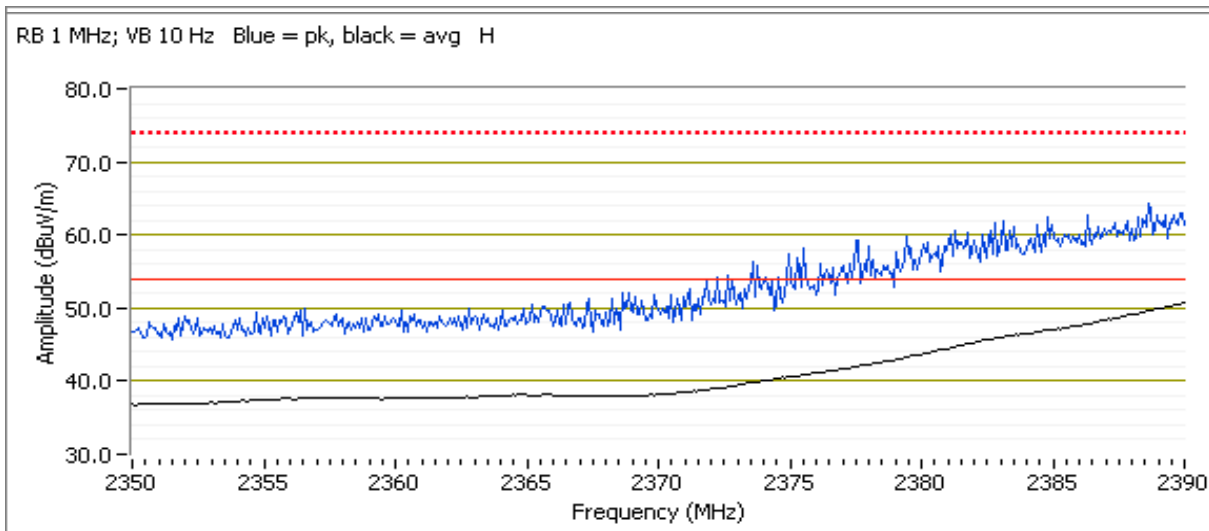



EMC Test Data

Client: Intel Corporation	Job Number: J94914
Model: 7265D2W	T-Log Number: T95471
Contact: Steve Hackett	Project Manager: Christine Krebill
Standard: FCC Part 15.247, 15.407, RSS-210	Project Coordinator: -
	Class: N/A

Channel: 2 Mode: n20
 Tx Chain: Both Data Rate: HT0

Chain	Target (dBm)				Power Settings Measured (dBm)				Software Setting
	A	B	C	Total	A	B	C	Total	
	13.5	13.5		16.5	13.5	13.6			17.0, 22.5

Band Edge Signal Field Strength - Direct measurement of field strength

Frequency	Level	Pol	15.209 / 15.247		Detector	Azimuth	Height	Comments
MHz	dB μ V/m	v/h	Limit	Margin	Pk/QP/Avg	degrees	meters	
2390.000	47.2	H	54.0	-6.8	AVG	69	1.27	POS; RB 1 MHz; VB: 10 Hz
2389.600	61.2	H	74.0	-12.8	PK	69	1.27	POS; RB 1 MHz; VB: 3 MHz
2390.000	49.4	V	54.0	-4.6	AVG	149	1.26	POS; RB 1 MHz; VB: 10 Hz
2389.440	62.9	V	74.0	-11.1	PK	149	1.26	POS; RB 1 MHz; VB: 3 MHz

Note 7 The setting .5 dB below target gave a result higher than .5 dB below limit.

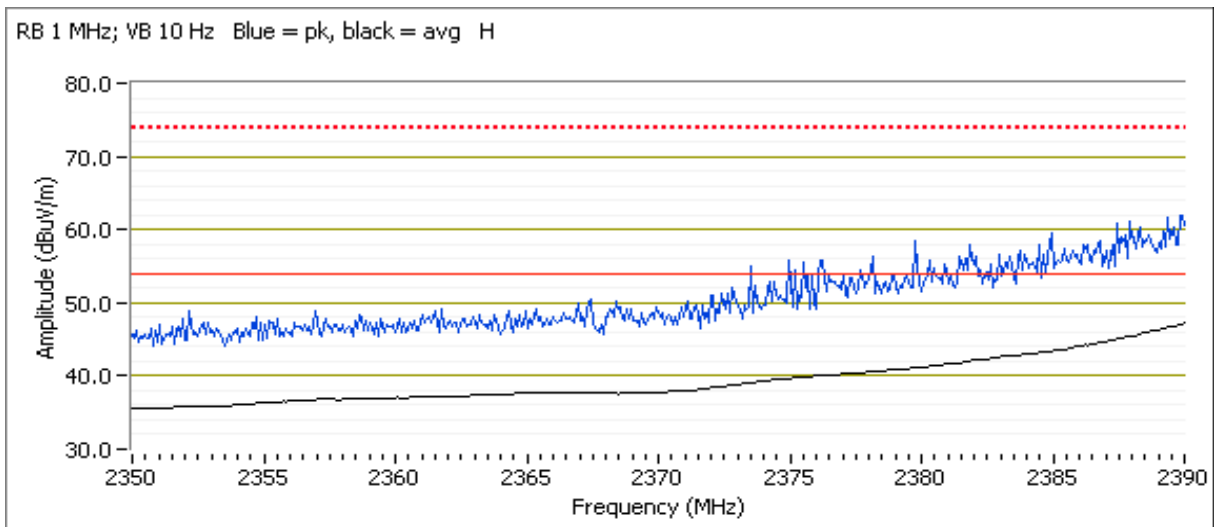



EMC Test Data

Client:	Intel Corporation	Job Number:	J94914
Model:	7265D2W	T-Log Number:	T95471
Contact:	Steve Hackett	Project Manager:	Christine Krebill
Standard:	FCC Part 15.247, 15.407, RSS-210	Project Coordinator:	-
		Class:	N/A

Channel: 3 Mode: n20
 Tx Chain: Both Data Rate: HT0

Chain	Target (dBm)				Power Settings Measured (dBm)				Software Setting
	A	B	C	Total	A	B	C	Total	
	17.5	17.5		20.5	17.3	17.5			23.0, 28.0

Band Edge Signal Field Strength - Direct measurement of field strength

Frequency	Level	Pol	15.209 / 15.247		Detector	Azimuth	Height	Comments
MHz	dB μ V/m	v/h	Limit	Margin	Pk/QP/Avg	degrees	meters	
2389.680	52.8	H	54.0	-1.2	AVG	216	1.19	POS; RB 1 MHz; VB: 10 Hz
2386.470	71.1	H	74.0	-2.9	PK	216	1.19	POS; RB 1 MHz; VB: 3 MHz

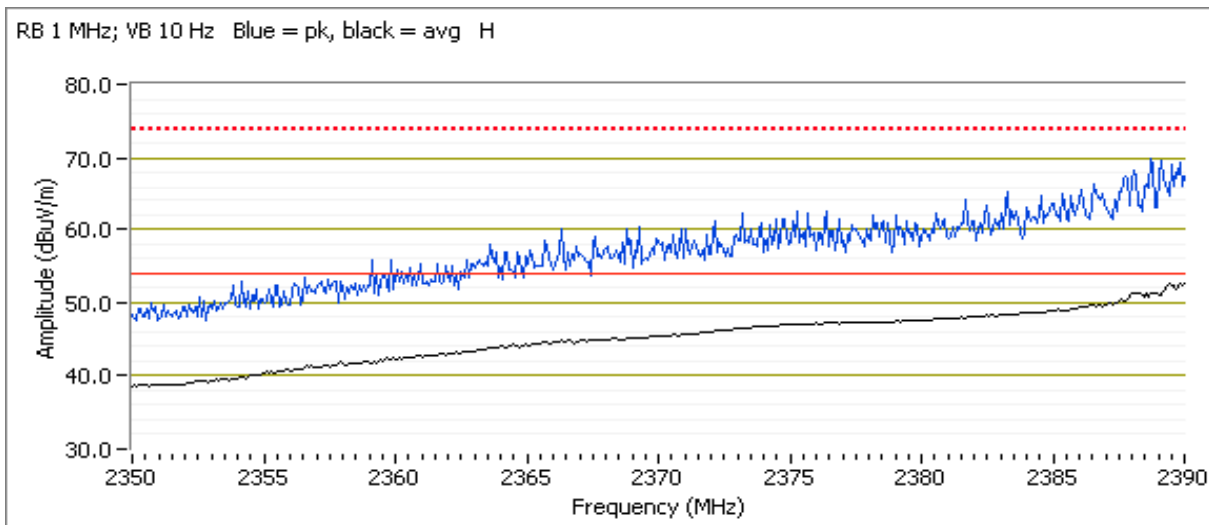



EMC Test Data

Client:	Intel Corporation	Job Number:	J94914
Model:	7265D2W	T-Log Number:	T95471
Contact:	Steve Hackett	Project Manager:	Christine Krebill
Standard:	FCC Part 15.247, 15.407, RSS-210	Project Coordinator:	-
		Class:	N/A

Channel: 9 Mode: n20
 Tx Chain: Both Data Rate: HT0

Chain	Target (dBm)				Power Settings Measured (dBm)				Software Setting
	A	B	C	Total	A	B	C	Total	
	17.5	17.5		20.5	17.5	17.6			21.5, 27.0

Band Edge Signal Field Strength - Direct measurement of field strength

Frequency	Level	Pol	15.209 / 15.247		Detector	Azimuth	Height	Comments
MHz	dB μ V/m	v/h	Limit	Margin	Pk/QP/Avg	degrees	meters	
2483.530	52.9	H	54.0	-1.1	AVG	172	1.15	POS; RB 1 MHz; VB: 10 Hz
2484.000	69.3	H	74.0	-4.7	PK	172	1.15	POS; RB 1 MHz; VB: 3 MHz

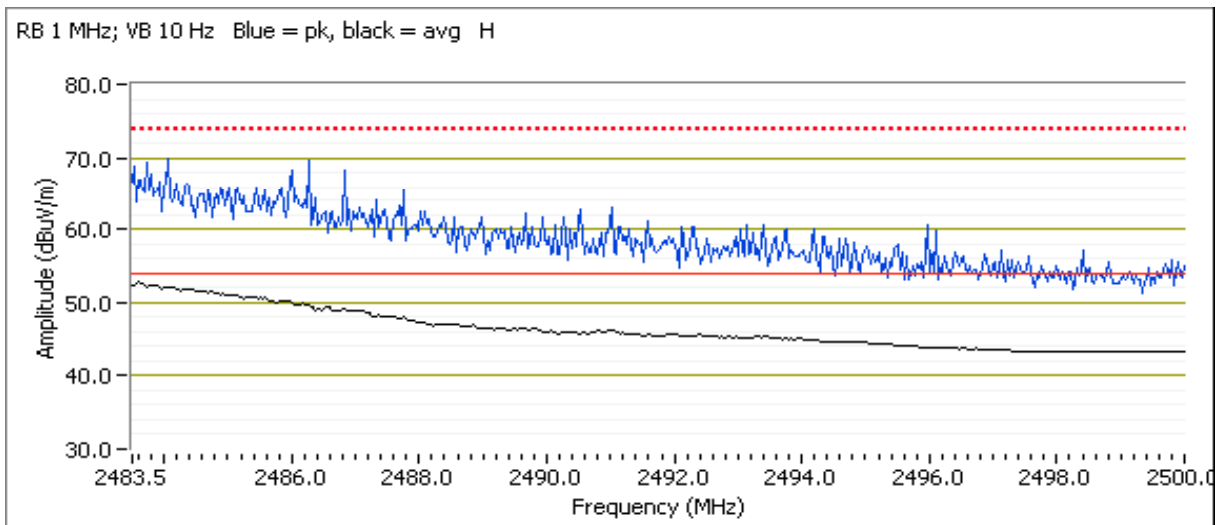



EMC Test Data

Client:	Intel Corporation	Job Number:	J94914
Model:	7265D2W	T-Log Number:	T95471
Contact:	Steve Hackett	Project Manager:	Christine Krebill
Standard:	FCC Part 15.247, 15.407, RSS-210	Project Coordinator:	-
		Class:	N/A

Channel: 10 Mode: n20
 Tx Chain: Both Data Rate: HT0

Chain	Target (dBm)				Power Settings Measured (dBm)				Software Setting
	A	B	C	Total	A	B	C	Total	
	13.5	13.5		16.5	13.5	13.5		16.5	16.0, 21.5

Band Edge Signal Field Strength - Direct measurement of field strength

Frequency	Level	Pol	15.209 / 15.247		Detector	Azimuth	Height	Comments
MHz	dB μ V/m	v/h	Limit	Margin	Pk/QP/Avg	degrees	meters	
2483.600	49.2	H	54.0	-4.8	AVG	174	1.17	POS; RB 1 MHz; VB: 10 Hz
2484.290	63.5	H	74.0	-10.5	PK	174	1.17	POS; RB 1 MHz; VB: 3 MHz

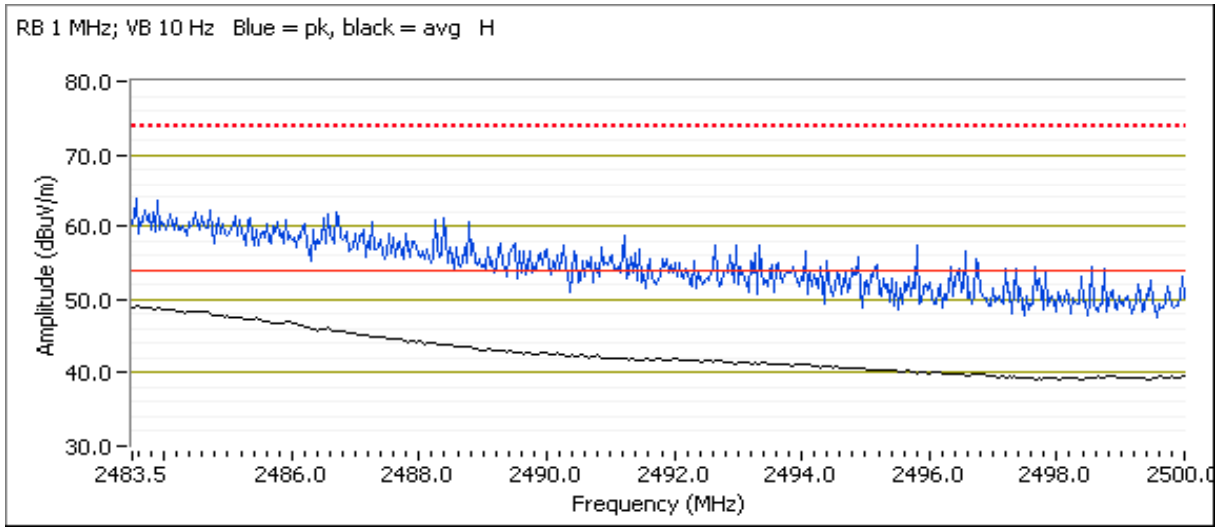



EMC Test Data

Client: Intel Corporation	Job Number: J94914
Model: 7265D2W	T-Log Number: T95471
Contact: Steve Hackett	Project Manager: Christine Krebill
Standard: FCC Part 15.247, 15.407, RSS-210	Project Coordinator: -
	Class: N/A

Date of Test: 6/10/2014 0:00	Config. Used: 1
Test Engineer: Jack Liu	Config Change: none
Test Location: Chamber 7	EUT Voltage: 3.3 VDC
Channel: 11	Mode: n20
Tx Chain: Both	Data Rate: HT0

Chain	Power Settings								Software Setting
	Target (dBm)				Measured (dBm)				
	A	B	C	Total	A	B	C	Total	
	12.0	12.0		15.0	12.0	10.3		14.2	16.5, 21

Band Edge Signal Field Strength - Direct measurement of field strength

Frequency	Level	Pol	15.209 / 15.247		Detector	Azimuth	Height	Comments
MHz	dB μ V/m	v/h	Limit	Margin	Pk/QP/Avg	degrees	meters	
2483.530	52.8	H	54.0	-1.2	AVG	176	1.1	POS; RB 1 MHz; VB: 10 Hz
2483.630	68.1	H	74.0	-5.9	PK	176	1.1	POS; RB 1 MHz; VB: 3 MHz
2483.500	43.7	V	54.0	-10.3	AVG	20	1.4	POS; RB 1 MHz; VB: 10 Hz
2483.530	59.2	V	74.0	-14.8	PK	20	1.4	POS; RB 1 MHz; VB: 3 MHz

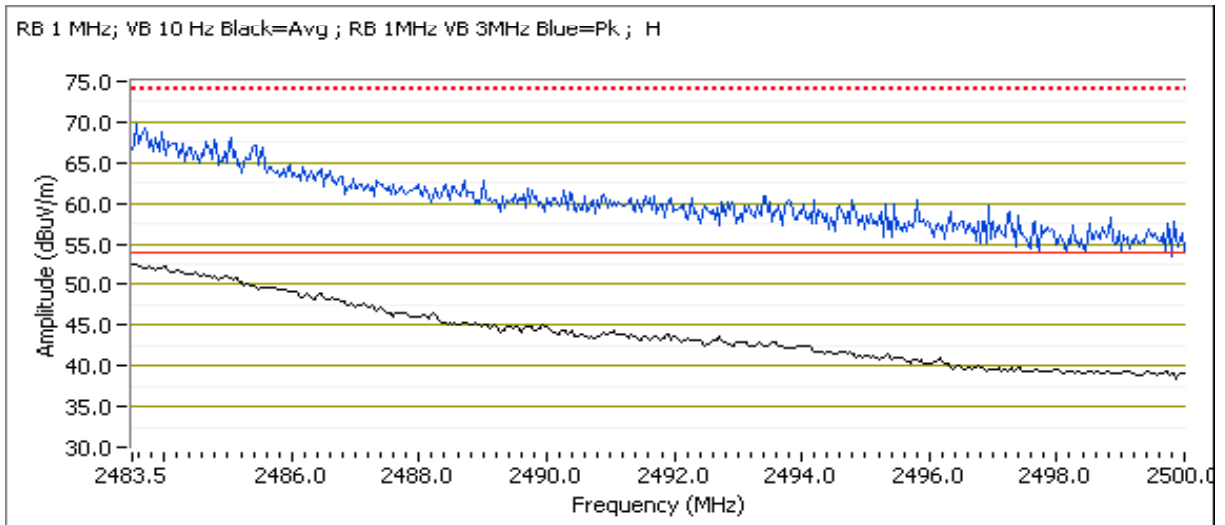



EMC Test Data

Client: Intel Corporation	Job Number: J94914
Model: 7265D2W	T-Log Number: T95471
Contact: Steve Hackett	Project Manager: Christine Krebill
Standard: FCC Part 15.247, 15.407, RSS-210	Project Coordinator: -
	Class: N/A

Run #2: Radiated Bandedge Measurements

Date of Test: 6/10/2014 0:00
 Test Engineer: Joseph Cadigal
 Test Location: FT Chamber#7

Config. Used: 1
 Config Change: none
 EUT Voltage: 3.3 VDC

Channel: 3 Mode: n40
 Tx Chain: Both Data Rate: HT0

Chain	Target (dBm)				Power Settings Measured (dBm)				Software Setting
	A	B	C	Total	A	B	C	Total	
	9.5	9.5		12.5	9.7	9.6		12.7	14.0, 19.5

Band Edge Signal Field Strength - Direct measurement of field strength

Frequency	Level	Pol	15.209 / 15.247		Detector	Azimuth	Height	Comments
MHz	dB μ V/m	v/h	Limit	Margin	Pk/QP/Avg	degrees	meters	
2389.920	47.4	H	54.0	-6.6	AVG	221	1.2	POS; RB 1 MHz; VB: 10 Hz, Note 1
2389.440	57.6	H	74.0	-16.4	PK	221	1.2	POS; RB 1 MHz; VB: 3 MHz
2390.000	45.0	V	54.0	-9.0	AVG	195	1.0	POS; RB 1 MHz; VB: 10 Hz, Note 1
2389.680	55.8	V	74.0	-18.2	PK	195	1.0	POS; RB 1 MHz; VB: 3 MHz

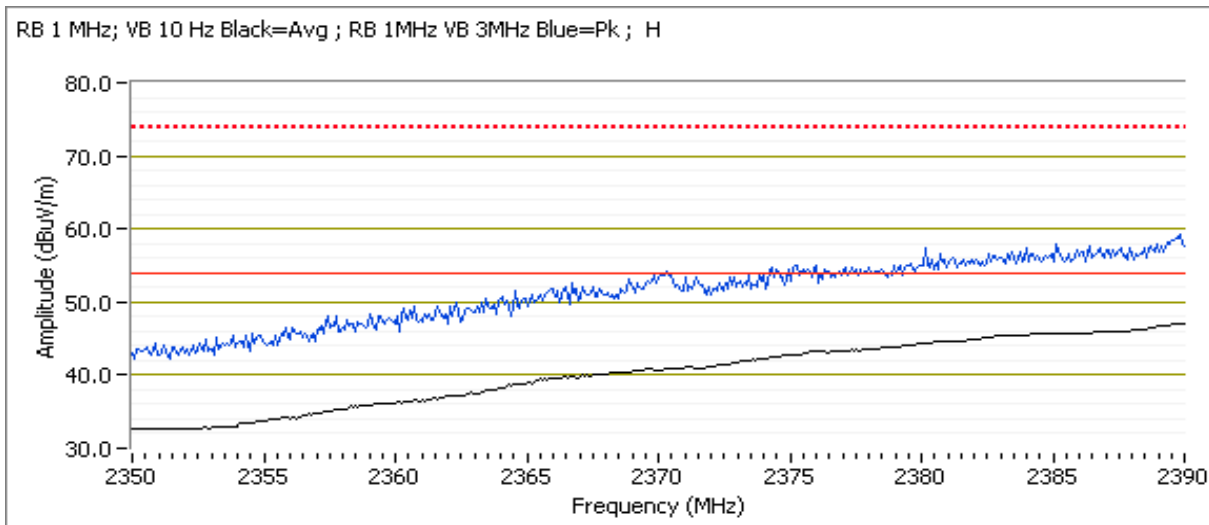



EMC Test Data

Client:	Intel Corporation	Job Number:	J94914
Model:	7265D2W	T-Log Number:	T95471
Contact:	Steve Hackett	Project Manager:	Christine Krebill
Standard:	FCC Part 15.247, 15.407, RSS-210	Project Coordinator:	-
		Class:	N/A

Channel:	4	Mode:	n40
Tx Chain:	Both	Data Rate:	HT0

Chain	Target (dBm)				Measured (dBm)				Software Setting
	A	B	C	Total	A	B	C	Total	
	11.5	11.5		14.5	11.0	11.0		14.0	15.5, 21

Band Edge Signal Field Strength - Direct measurement of field strength

Frequency	Level	Pol	15.209 / 15.247		Detector	Azimuth	Height	Comments
MHz	dB μ V/m	v/h	Limit	Margin	Pk/QP/Avg	degrees	meters	
2389.360	49.1	H	54.0	-4.9	AVG	220	1.2	POS; RB 1 MHz; VB: 10 Hz, Note 1
2383.750	59.8	H	74.0	-14.2	PK	220	1.2	POS; RB 1 MHz; VB: 3 MHz
2390.000	43.2	V	54.0	-11.0	AVG	248	2.3	POS; RB 1 MHz; VB: 10 Hz, Note 1
2389.280	52.7	V	74.0	-21.3	PK	248	2.3	POS; RB 1 MHz; VB: 3 MHz

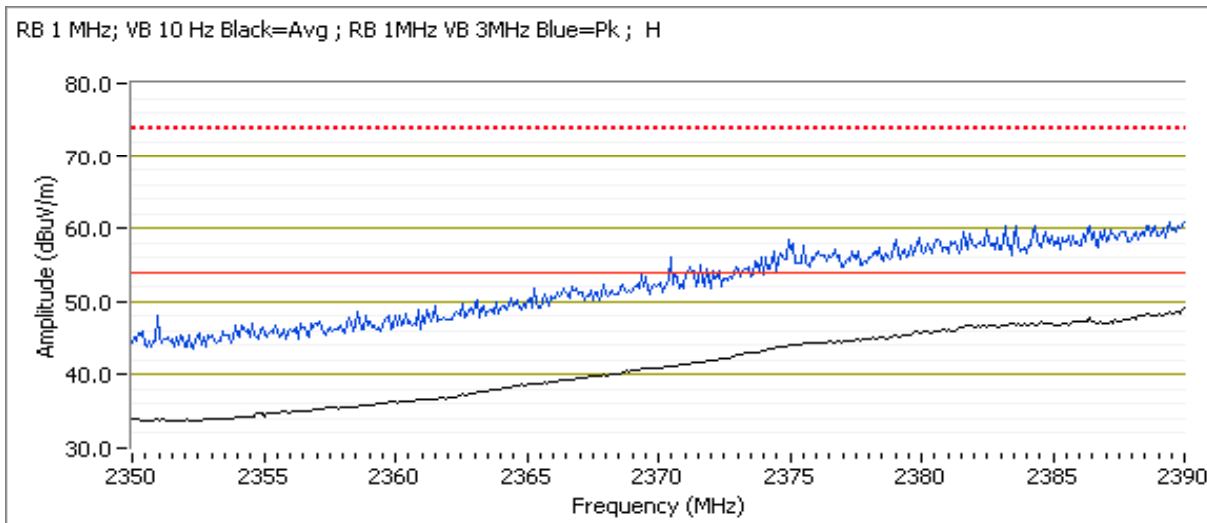



EMC Test Data

Client:	Intel Corporation	Job Number:	J94914
Model:	7265D2W	T-Log Number:	T95471
Contact:	Steve Hackett	Project Manager:	Christine Krebill
Standard:	FCC Part 15.247, 15.407, RSS-210	Project Coordinator:	-
		Class:	N/A

Channel:	7	Mode:	n40
Tx Chain:	Both	Data Rate:	HT0

Chain	Target (dBm)				Measured (dBm)				Software Setting
	A	B	C	Total	A	B	C	Total	
	11.5	11.5		14.5	9.5	11.0		13.3	14.0, 20.0

Band Edge Signal Field Strength - Direct measurement of field strength

Frequency	Level	Pol	15.209 / 15.247		Detector	Azimuth	Height	Comments
MHz	dB μ V/m	v/h	Limit	Margin	Pk/QP/Avg	degrees	meters	
2483.500	52.2	H	54.0	-1.8	AVG	172	1.2	POS; RB 1 MHz; VB: 10 Hz, Note 1
2484.360	62.8	H	74.0	-14.2	PK	172	1.2	POS; RB 1 MHz; VB: 3 MHz
2483.530	43.8	V	54.0	-11.0	AVG	282	1.1	POS; RB 1 MHz; VB: 10 Hz, Note 1
2483.700	58.3	V	74.0	-21.3	PK	282	1.1	POS; RB 1 MHz; VB: 3 MHz

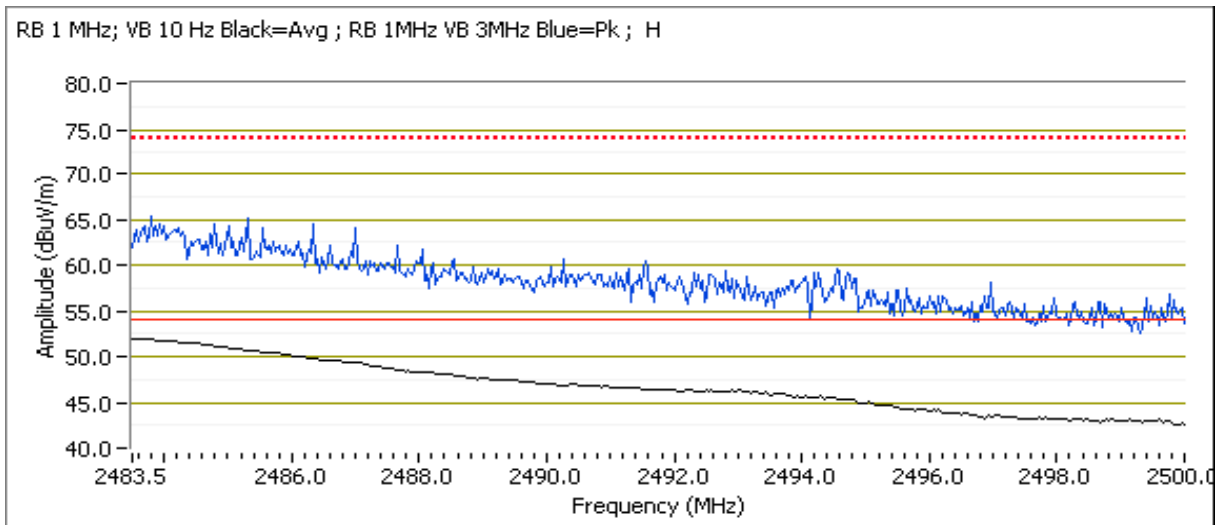



EMC Test Data

Client:	Intel Corporation	Job Number:	J94914
Model:	7265D2W	T-Log Number:	T95471
Contact:	Steve Hackett	Project Manager:	Christine Krebill
Standard:	FCC Part 15.247, 15.407, RSS-210	Project Coordinator:	-
		Class:	N/A

Channel:	8	Mode:	n40
Tx Chain:	Both	Data Rate:	HT0

Chain	Target (dBm)				Measured (dBm)				Software Setting
	A	B	C	Total	A	B	C	Total	
	10.5	10.5		13.5	10.8	10.8		13.8	15.0, 21.0

Band Edge Signal Field Strength - Direct measurement of field strength

Frequency	Level	Pol	15.209 / 15.247		Detector	Azimuth	Height	Comments
MHz	dB μ V/m	v/h	Limit	Margin	Pk/QP/Avg	degrees	meters	
2483.500	52.9	H	54.0	-1.1	AVG	172	1.7	POS; RB 1 MHz; VB: 10 Hz, Note 1
2484.160	65.4	H	74.0	-14.2	PK	172	1.7	POS; RB 1 MHz; VB: 3 MHz
2483.630	46.4	V	54.0	-11.0	AVG	282	1.0	POS; RB 1 MHz; VB: 10 Hz, Note 1
2484.560	59.1	V	74.0	-21.3	PK	282	1.0	POS; RB 1 MHz; VB: 3 MHz

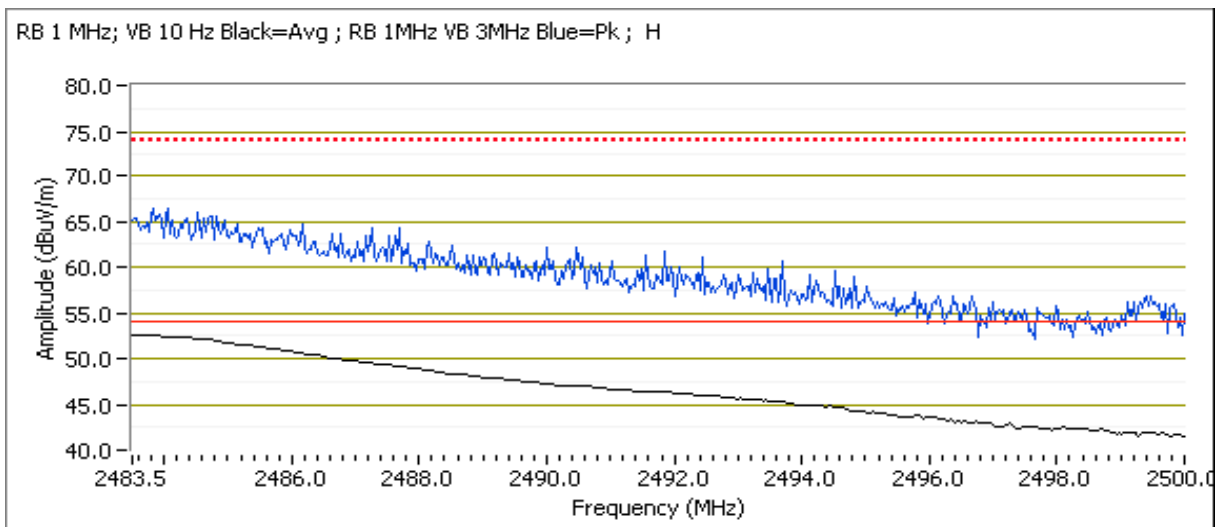



EMC Test Data

Client:	Intel Corporation	Job Number:	J94914
Model:	7265D2W	T-Log Number:	T95471
Contact:	Steve Hackett	Project Manager:	Christine Krebill
Standard:	FCC Part 15.247, 15.407, RSS-210	Project Coordinator:	-
		Class:	N/A

Channel:	9	Mode:	n40
Tx Chain:	Both	Data Rate:	HT0

Chain	Target (dBm)				Measured (dBm)				Software Setting
	A	B	C	Total	A	B	C	Total	
	9.5	9.5		12.5	9.4	9.4		12.4	13.5, 19.5

Band Edge Signal Field Strength - Direct measurement of field strength

Frequency	Level	Pol	15.209 / 15.247		Detector	Azimuth	Height	Comments
MHz	dB μ V/m	v/h	Limit	Margin	Pk/QP/Avg	degrees	meters	
2483.500	53.0	H	54.0	-1.0	AVG	169	1.1	POS; RB 1 MHz; VB: 10 Hz, Note 1
2484.890	64.8	H	74.0	-14.2	PK	169	1.1	POS; RB 1 MHz; VB: 3 MHz
2483.670	47.4	V	54.0	-11.0	AVG	282	1.1	POS; RB 1 MHz; VB: 10 Hz, Note 1
2484.130	58.7	V	74.0	-21.3	PK	282	1.1	POS; RB 1 MHz; VB: 3 MHz

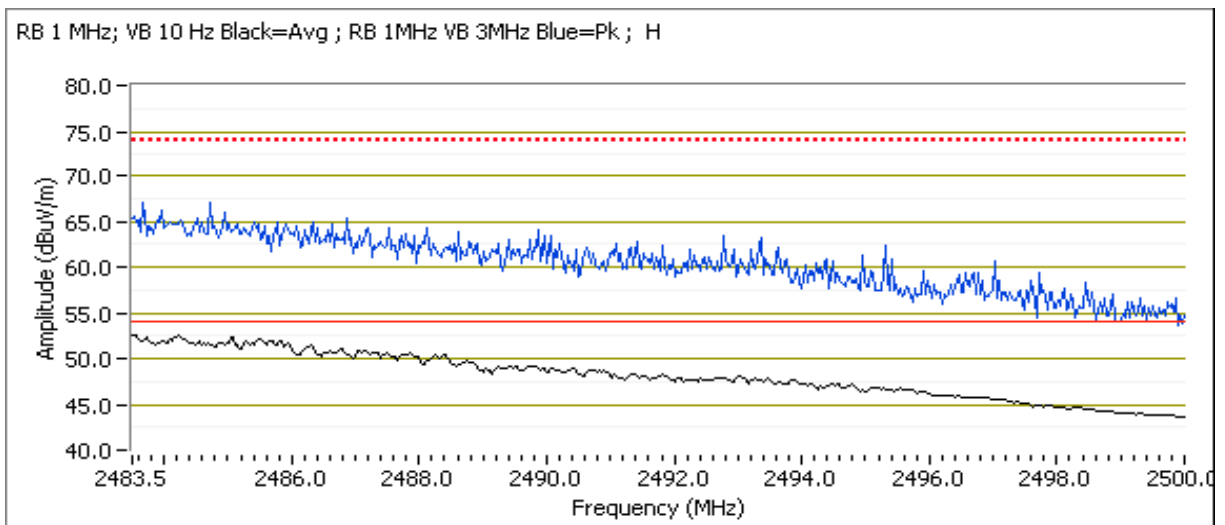



EMC Test Data

Client:	Intel Corporation	Job Number:	J94914
Model:	7265D2W	T-Log Number:	T95471
Contact:	Steve Hackett	Project Manager:	Christine Krebill
Standard:	FCC Part 15.247, 15.407, RSS-210	Project Coordinator:	-
		Class:	N/A

RSS 210 and FCC 15.247 (DTS) Radiated Spurious Emissions

Test Specific Details

Objective: The objective of this test session is to perform final qualification testing of the EUT with respect to the specification listed above.

General Test Configuration

The EUT and all local support equipment were located on the turntable for radiated spurious emissions testing.

For radiated emissions testing the measurement antenna was located 3 meters from the EUT, unless otherwise noted.

Ambient Conditions:

Temperature: ??? °C
 Rel. Humidity: ??? %

Summary of Results - Device Operating in the 2400-2483.5 MHz Band

Run #	Mode	Channel	Target Power	Power Setting	Test Performed	Limit	Result / Margin
1	b - Chain A	1 - 2412MHz	16.5	15.5	Radiated Emissions, 1 - 25 GHz	FCC Part 15.209 / 15.247(c)	49.3 dBµV/m @ 3000.2 MHz (-4.7 dB)
		7 - 2442MHz	17.5	15.0			39.5 dBµV/m @ 4884.0 MHz (-14.5 dB)
		11 - 2462MHz	16.5	14.0			46.7 dBµV/m @ 4924.0 MHz (-7.3 dB)
2	b - Chain B	1 - 2412MHz	16.5	21.5			40.6 dBµV/m @ 4824.0 MHz (-13.4 dB)
		7 - 2442MHz	17.5	22.0			39.9 dBµV/m @ 4884.0 MHz (-14.1 dB)
		11 - 2462MHz	16.5	21.0			42.7 dBµV/m @ 4924.0 MHz (-11.3 dB)

Scans on center channel in all three OFDM modes to determine the worst case mode.

3	g - Chain A	7 - 2442MHz	17.5	21.0	Radiated Emissions, 1 - 25 GHz	FCC Part 15.209 / 15.247(c)	40.3 dBµV/m @ 1599.1 MHz (-13.7 dB)
	g - Chain B	7 - 2442MHz	17.5	27.0			39.4 dBµV/m @ 11678.9 MHz (-14.6 dB)
	n20 - Chain A+B	7 - 2442MHz	17.5	23.0 / 29.0			33.4 dBµV/m @ 1598.8 MHz (-20.6 dB)
	n40 - Chain A+B	6 - 2437MHz	16.5	23.0 / 28.0			35.4 dBµV/m @ 1598.6 MHz (-18.6 dB)



EMC Test Data

Client:	Intel Corporation	Job Number:	J94914
Model:	7265D2W	T-Log Number:	T95471
Contact:	Steve Hackett	Project Manager:	Christine Krebill
Standard:	FCC Part 15.247, 15.407, RSS-210	Project Coordinator:	-
		Class:	N/A

Measurements on low and high channels in worst-case OFDM mode.

4	g - Chain B	1 - 2412MHz	14.5	24.0	Radiated Emissions, 1 - 25 GHz	FCC Part 15.209 / 15.247(c)	No radio realated emissions
	g - Chain B	11 - 2462MHz	0.0	8.0			No radio realated emissions
	n20 - Chain A+B	1 - 2412MHz	12 / 12	16 / 21	Radiated Emissions, 1 - 25 GHz	FCC Part 15.209 / 15.247(c)	No radio realated emissions
	n20 - Chain A+B	11 - 2462MHz	0.0	4 / 8.5			No radio realated emissions

Modifications Made During Testing

No modifications were made to the EUT during testing

Deviations From The Standard

No deviations were made from the requirements of the standard.

Sample Notes

MAC Address: 001500F15B5D DRTU Tool Version 1.7.3-935 Driver version 17.1.0.11

Antenna:

Procedure Comments:

Measurements performed in accordance with FCC KDB 558074

Peak measurements performed with: RBW=1MHz, VBW=3MHz, peak detector, max hold, auto sweep time.

Unless otherwise stated/noted, emission has duty cycle $\geq 98\%$ and was measured using RBW=1MHz, VBW=10Hz, peak detector, linear average mode, auto sweep time, max hold.

2.4GHz band reject filter used

Mode	Data Rate	Duty Cycle (x)	Constant DC?	T (ms)	Pwr Cor Factor*	Lin Volt Cor Factor**	Min VBW for FS (Hz)
11b	1	0.99	Yes	2.272	0.0	0.0	440
11g	6	0.99	Yes	2.06	0.0	0.0	485
n20	HT0	0.99	Yes	1.919	0.0	0.0	521
n40	HT0	0.97	Yes	0.944	0.1	0.2	1059



EMC Test Data

Client:	Intel Corporation	Job Number:	J94914
Model:	7265D2W	T-Log Number:	T95471
		Project Manager:	Christine Krebill
Contact:	Steve Hackett	Project Coordinator:	-
Standard:	FCC Part 15.247, 15.407, RSS-210	Class:	N/A

Measurement Specific Notes:

Note 1:	Emission in non-restricted band, but limit of 15.209 used.
Note 2:	Emission in non-restricted band, the limit was set 20dB below the level of the fundamental and measured in 100kHz.
Note 3:	Emission has duty cycle < 98%, but constant, average measurement performed: RBW=1MHz, VBW=10Hz, peak detector, linear averaging, auto sweep, trace average 100 traces, measurement corrected by Linear Voltage correction factor
Note 4:	Signal does not change with channel, not radio related, measured in run 1a.



EMC Test Data

Client: Intel Corporation	Job Number: J94914
Model: 7265D2W	T-Log Number: T95471
Contact: Steve Hackett	Project Manager: Christine Krebill
Standard: FCC Part 15.247, 15.407, RSS-210	Project Coordinator: -
	Class: N/A

Run #1: Radiated Spurious Emissions, 1,000 - 25000 MHz. Operating Mode: 802.11b

Date of Test: 6/11/2014, 6/12/2014
 Test Engineer: John Caizzi / Deniz Demirci
 Test Location: Chamber 7
 Config. Used: 1
 Config Change: none
 EUT Voltage: 3.3 VDC

Run #1a: Low Channel

Channel: 1
 Tx Chain: A
 Mode: b
 Data Rate: 1

Power Settings		
Target (dBm)	Measured (dBm)	Software Setting
16.5	17.7	15.5

Frequency MHz	Level dB μ V/m	Pol v/h	15.209 / 15.247		Detector Pk/QP/Avg	Azimuth degrees	Height meters	Comments
			Limit	Margin				
1499.200	44.9	H	54.0	-9.1	AVG	210	1.25	
1499.370	52.5	H	74.0	-21.5	PK	210	1.25	
1599.000	40.1	V	54.0	-13.9	AVG	286	1.02	
1592.170	56.5	V	74.0	-17.5	PK	286	1.02	
3000.220	49.3	V	54.0	-4.7	PK	10	1.00	Note 1
6000.450	45.8	V	54.0	-8.2	PK	12	1.00	Note 1

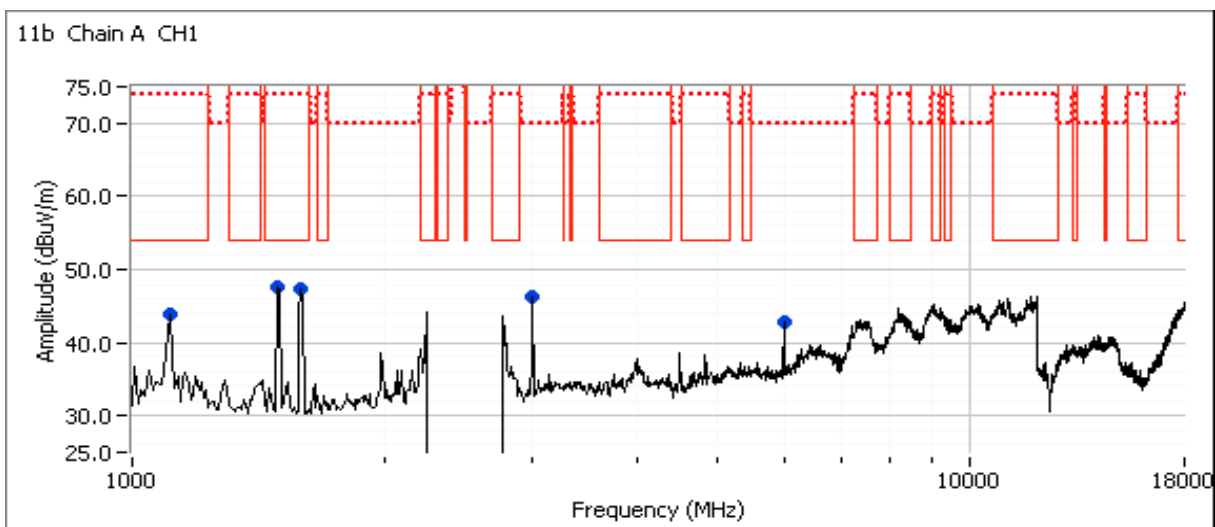



EMC Test Data

Client: Intel Corporation	Job Number: J94914
Model: 7265D2W	T-Log Number: T95471
Contact: Steve Hackett	Project Manager: Christine Krebill
Standard: FCC Part 15.247, 15.407, RSS-210	Project Coordinator: -
	Class: N/A

Run #1b: Center Channel

Channel: 7 Mode: b
 Tx Chain: A Data Rate: 1

Power Settings		
Target (dBm)	Measured (dBm)	Software Setting
17.5	17.3	15.0

Frequency MHz	Level dB μ V/m	Pol v/h	15.209 / 15.247		Detector Pk/QP/Avg	Azimuth degrees	Height meters	Comments
			Limit	Margin				
10620.000	48.4	H	54.0	-5.6	Peak	350	2.5	Emission not seen when investigated
1591.670	48.3	V	54.0	-5.7	Peak	258	1.0	Note 4
1491.670	47.9	H	54.0	-6.1	Peak	208	1.5	Note 4
3000.000	45.3	V	54.0	-8.7	Peak	3	1.0	Note 1, note 4
5991.670	43.7	V	54.0	-10.3	Peak	10	1.0	Note 1, note 4
4500.000	38.3	V	54.0	-15.7	Peak	278	1.0	Note 1
4883.990	39.5	V	54.0	-14.5	AVG	111	1.02	
4884.020	45.2	V	74.0	-28.8	PK	111	1.02	

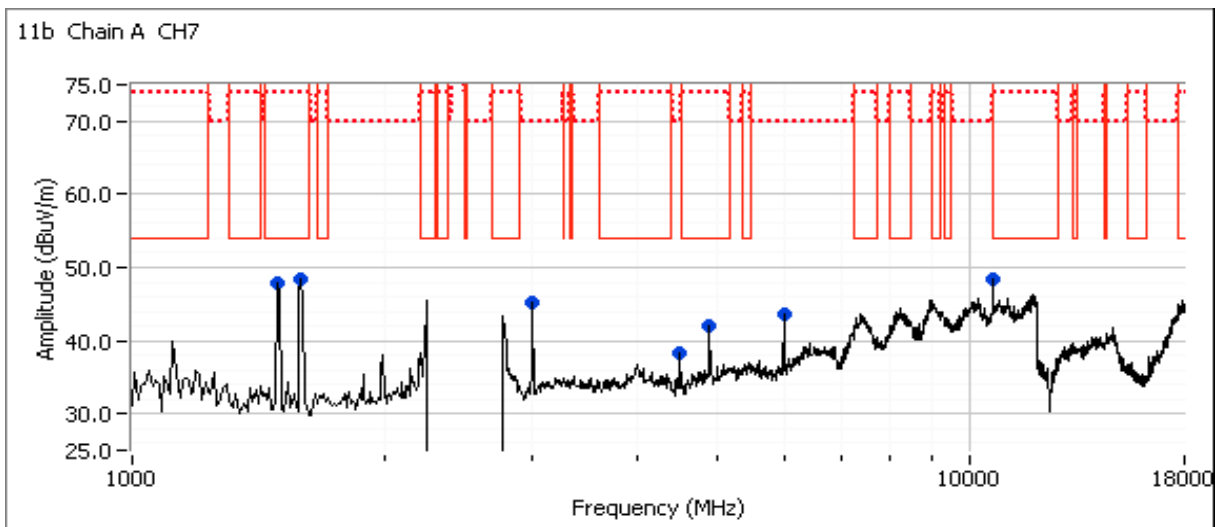

Client: Intel Corporation	Job Number: J94914
Model: 7265D2W	T-Log Number: T95471
Contact: Steve Hackett	Project Manager: Christine Krebill
Standard: FCC Part 15.247, 15.407, RSS-210	Project Coordinator: -
	Class: N/A

Note: Scans made between 18 - 25 GHz with the measurement antenna moved around the card and its antennas 20-50cm from the device indicated there were no significant emissions in this frequency range

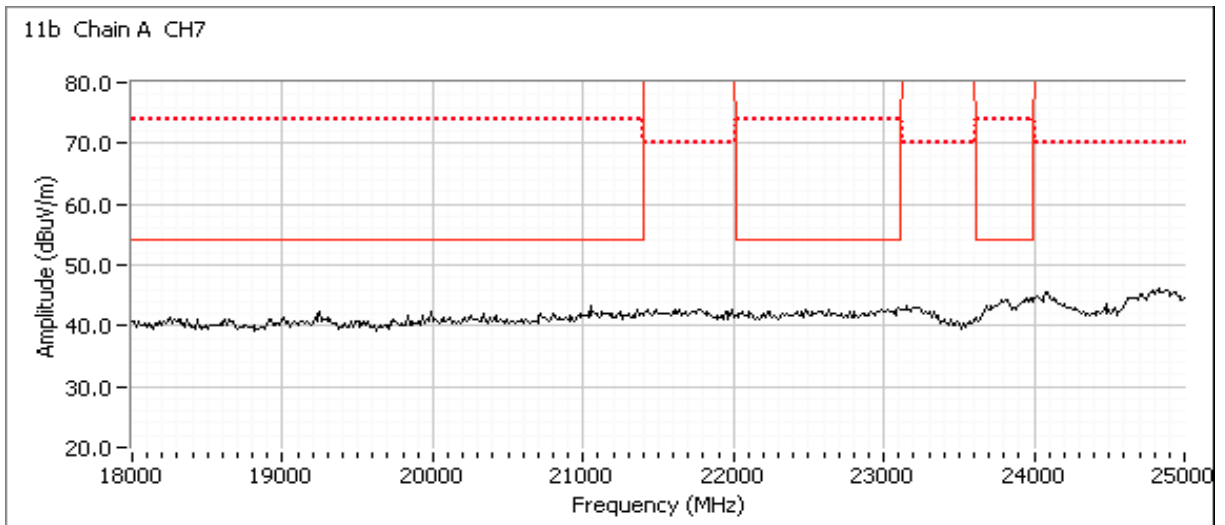



EMC Test Data

Client: Intel Corporation	Job Number: J94914
Model: 7265D2W	T-Log Number: T95471
Contact: Steve Hackett	Project Manager: Christine Krebill
Standard: FCC Part 15.247, 15.407, RSS-210	Project Coordinator: -
	Class: N/A

Run #1c: High Channel

Channel: 11 Mode: b
 Tx Chain: A Data Rate: 1

Power Settings		
Target (dBm)	Measured (dBm)	Software Setting
16.5	16.7	14.0

Frequency MHz	Level dB μ V/m	Pol v/h	15.209 / 15.247		Detector Pk/QP/Avg	Azimuth degrees	Height meters	Comments
			Limit	Margin				
4924.010	46.7	V	54.0	-7.3	AVG	163	1.0	POS; RB 1 MHz; VB: 10 Hz
4924.220	56.4	V	74.0	-17.6	PK	163	1.0	POS; RB 1 MHz; VB: 3 MHz
4924.020	45.9	H	54.0	-8.1	AVG	140	1.0	POS; RB 1 MHz; VB: 10 Hz
4923.790	56.5	H	74.0	-17.5	PK	140	1.0	POS; RB 1 MHz; VB: 3 MHz
1591.670	48.4	V	54.0	-5.6	Peak	272	1.0	Note 4
1491.670	47.6	H	54.0	-6.2	Peak	220	1.5	Note 4
3000.000	47.2	V	54.0	-6.8	Peak	12	1.0	Note 1, note 4
5991.670	42.0	V	54.0	-12.0	Peak	12	1.0	Note 1, note 4

Note: Scans made between 18 - 25 GHz with the measurement antenna moved around the card and its antennas 20-50cm from the device indicated there were no significant emissions in this frequency range

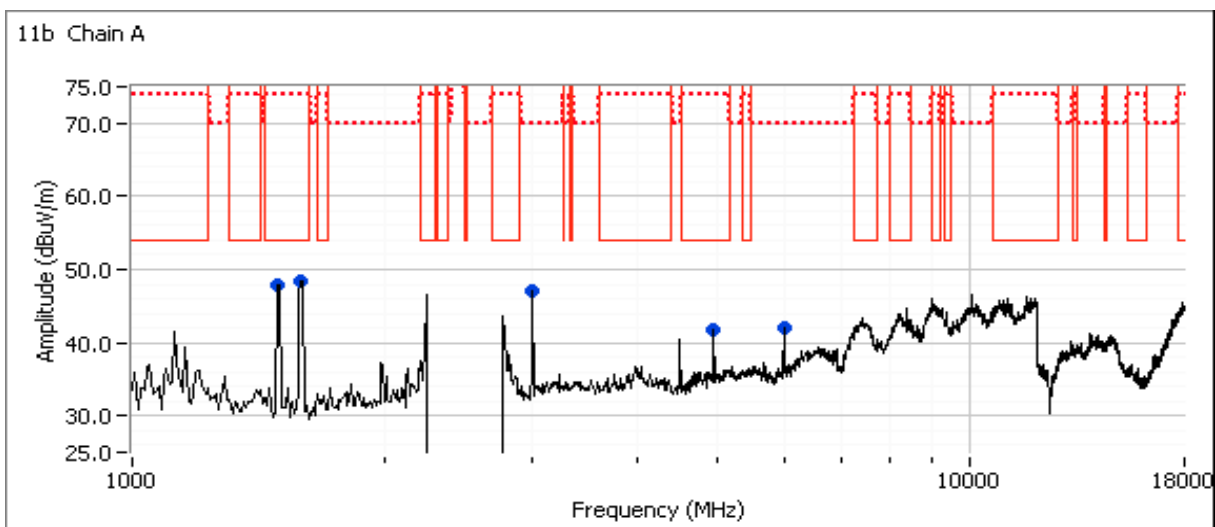



EMC Test Data

Client: Intel Corporation	Job Number: J94914
Model: 7265D2W	T-Log Number: T95471
	Project Manager: Christine Krebill
Contact: Steve Hackett	Project Coordinator: -
Standard: FCC Part 15.247, 15.407, RSS-210	Class: N/A

Run #2: Radiated Spurious Emissions, 1,000 - 25000 MHz. Operating Mode: 802.11b

Run #2a: Low Channel

Channel: 1 Mode: b
 Tx Chain: B Data Rate: 1

Power Settings		
Target (dBm)	Measured (dBm)	Software Setting
16.5	17.4	21.5

Frequency MHz	Level dB μ V/m	Pol v/h	15.209 / 15.247		Detector Pk/QP/Avg	Azimuth degrees	Height meters	Comments
			Limit	Margin				
1591.670	48.8	V	54.0	-5.2	Peak	280	1.0	Note 4
1491.670	47.6	H	54.0	-6.4	Peak	228	1.5	Note 4
3000.000	46.2	V	54.0	-7.8	Peak	12	1.0	Note 1, note 4
5991.670	42.0	V	54.0	-12.0	Peak	254	1.0	Note 1, note 4
4823.980	40.6	V	54.0	-13.4	AVG	223	1.0	
4823.830	45.7	V	74.0	-28.3	PK	223	1.0	

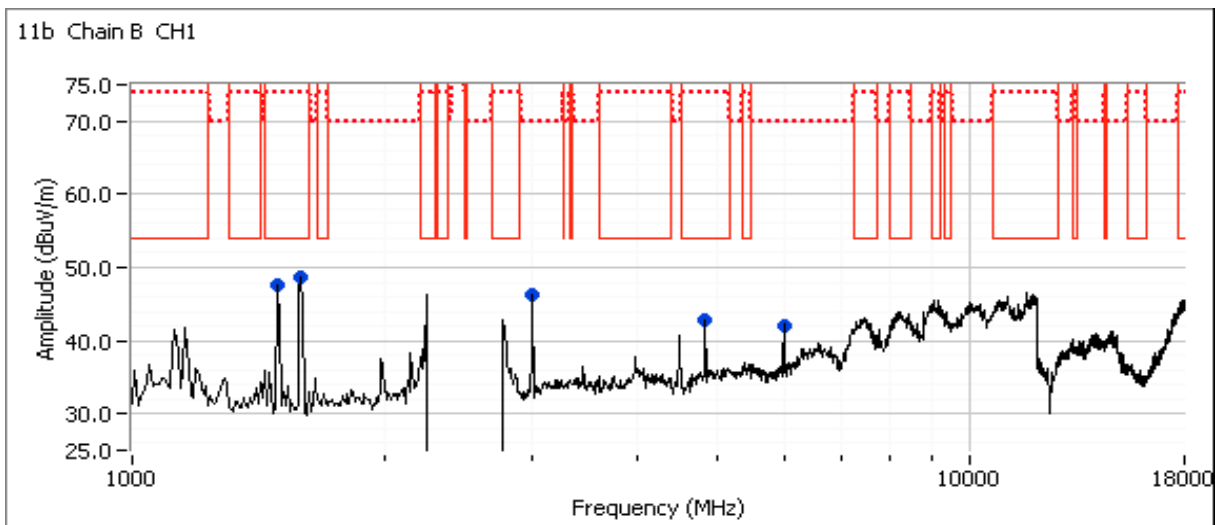



EMC Test Data

Client: Intel Corporation	Job Number: J94914
Model: 7265D2W	T-Log Number: T95471
Contact: Steve Hackett	Project Manager: Christine Krebill
Standard: FCC Part 15.247, 15.407, RSS-210	Project Coordinator: -
	Class: N/A

Run #2b: Center Channel

Channel: 7 Mode: b
 Tx Chain: B Data Rate: 1

Power Settings		
Target (dBm)	Measured (dBm)	Software Setting
17.5	17.7	22.0

Frequency MHz	Level dB μ V/m	Pol v/h	15.209 / 15.247		Detector Pk/QP/Avg	Azimuth degrees	Height meters	Comments
			Limit	Margin				
1600.000	49.6	V	54.0	-4.4	Peak	260	1.0	Note 4
1491.670	48.4	H	54.0	-5.6	Peak	211	1.5	Note 4
3000.000	47.0	V	54.0	-7.0	Peak	5	1.0	Note 1, note 4
4883.330	41.6	V	54.0	-12.4	Peak	222	1.0	
5991.670	42.5	V	54.0	-11.5	Peak	249	1.0	Note 1, note 4
4883.950	39.9	V	54.0	-14.1	AVG	226	1.00	
4884.160	45.3	V	74.0	-28.7	PK	226	1.00	

Note: Scans made between 18 - 25 GHz with the measurement antenna moved around the card and its antennas 20-50cm from the device indicated there were no significant emissions in this frequency range

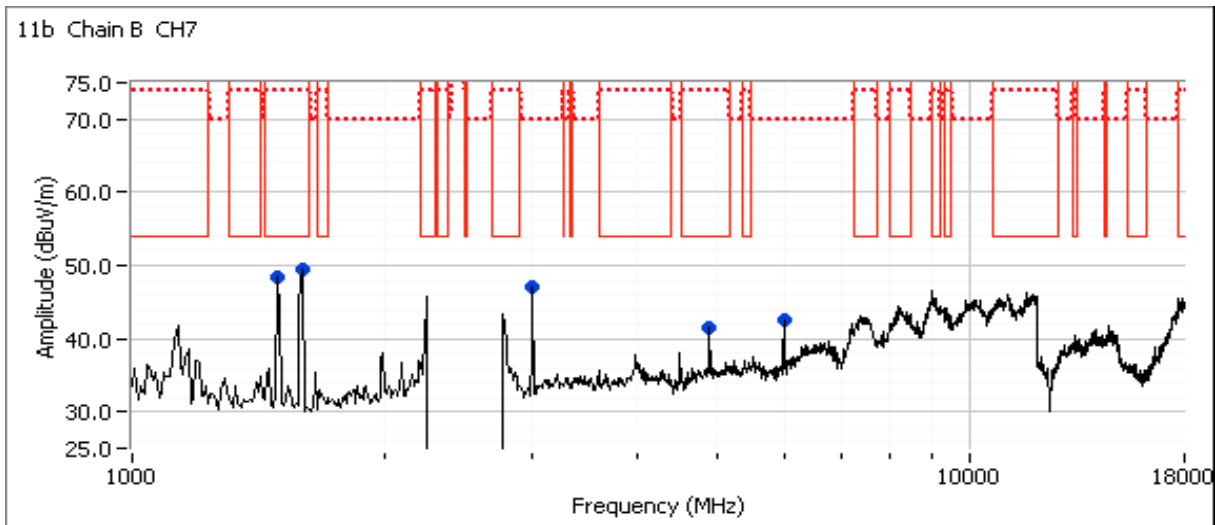



EMC Test Data

Client: Intel Corporation	Job Number: J94914
Model: 7265D2W	T-Log Number: T95471
Contact: Steve Hackett	Project Manager: Christine Krebill
Standard: FCC Part 15.247, 15.407, RSS-210	Project Coordinator: -
	Class: N/A

Run #2c: High Channel

Channel: 11 Mode: b
 Tx Chain: B Data Rate: 1

Power Settings		
Target (dBm)	Measured (dBm)	Software Setting
16.5	16.6	21.0

Frequency MHz	Level dB μ V/m	Pol v/h	15.209 / 15.247		Detector Pk/QP/Avg	Azimuth degrees	Height meters	Comments
			Limit	Margin				
4924.020	42.7	V	54.0	-11.3	AVG	307	1.0	POS; RB 1 MHz; VB: 10 Hz
4916.970	55.2	V	74.0	-18.8	PK	307	1.0	POS; RB 1 MHz; VB: 3 MHz
4924.020	42.4	H	54.0	-11.6	AVG	191	1.3	POS; RB 1 MHz; VB: 10 Hz
4926.790	55.0	H	74.0	-19.0	PK	191	1.3	POS; RB 1 MHz; VB: 3 MHz
4943.950	39.8	V	54.0	-14.2	AVG	159	1.14	
1491.670	48.3	H	54.0	-5.7	Peak	217	1.5	Note 4
3000.000	47.7	V	54.0	-6.3	Peak	7	1.0	Note 1, note 4
1591.670	47.6	V	54.0	-6.4	Peak	257	1.0	Note 4
1158.330	43.9	V	54.0	-10.1	Peak	215	1.0	
6000.000	43.6	V	54.0	-10.4	Peak	12	1.0	Note 1, note 4
4941.670	43.4	V	54.0	-10.6	Peak	194	1.0	

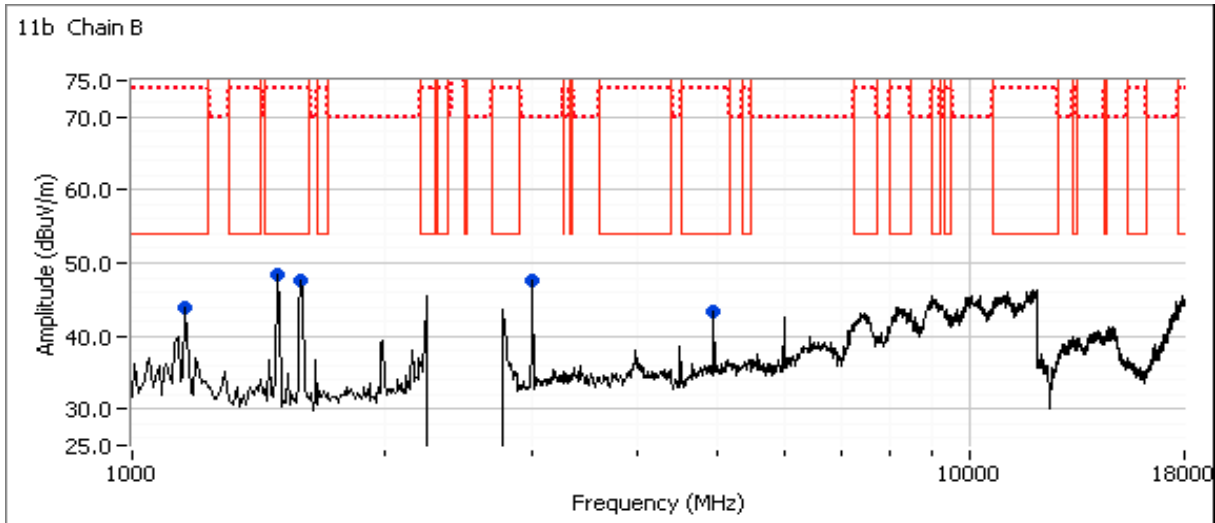

Note: Scans made between 18 - 25 GHz with the measurement antenna moved around the card and its antennas 20-50cm from the device indicated there were no significant emissions in this frequency range



EMC Test Data

Client: Intel Corporation	Job Number: J94914
Model: 7265D2W	T-Log Number: T95471
Contact: Steve Hackett	Project Manager: Christine Krebill
Standard: FCC Part 15.247, 15.407, RSS-210	Project Coordinator: -
	Class: N/A

Run #3: Radiated Spurious Emissions, 1,000 - 25000 MHz. Operating Mode: OFDM
 Date of Test: 6/11/2014 0:00 Config. Used: 1
 Test Engineer: John Caizzi / Jack Liu Config Change: none
 Test Location: Chamber 7 EUT Voltage: 3.3 VDC

Run #3a: Center Channel

Channel: 7 Mode: g
 Tx Chain: A Data Rate: 6

Power Settings		
Target (dBm)	Measured (dBm)	Software Setting
17.5	17.5	21.0

Frequency MHz	Level dBμV/m	Pol v/h	15.209 / 15.247		Detector Pk/QP/Avg	Azimuth degrees	Height meters	Comments
			Limit	Margin				
1591.670	50.8	V	54.0	-3.2	Peak	289	1.0	
1491.670	47.4	H	54.0	-6.6	Peak	227	1.5	Note 4
3000.000	46.5	V	54.0	-7.5	Peak	12	1.0	Note 1, note 4
6000.000	42.1	V	54.0	-11.9	Peak	253	1.0	Note 1, note 4
1599.140	40.3	V	54.0	-13.7	AVG	276	1.0	Note 4
1592.200	57.1	V	74.0	-16.9	PK	276	1.0	Note 4

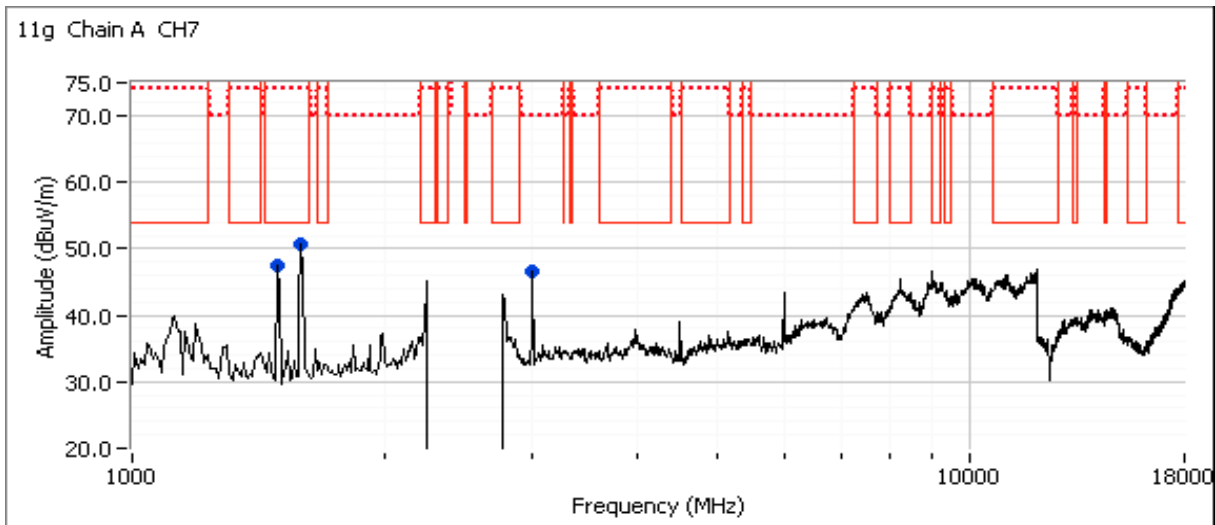

Note: Scans made between 18 - 25 GHz with the measurement antenna moved around the card and its antennas 20-50cm from the device indicated there were no significant emissions in this frequency range



EMC Test Data

Client: Intel Corporation	Job Number: J94914
Model: 7265D2W	T-Log Number: T95471
Contact: Steve Hackett	Project Manager: Christine Krebill
Standard: FCC Part 15.247, 15.407, RSS-210	Project Coordinator: -
	Class: N/A

Date of Test: 6/11/2014 0:00
 Test Engineer: Jack Liu
 Test Location: Chamber 7

Config. Used: 1
 Config Change: none
 EUT Voltage: 3.3 VDC

Run #3b: Center Channel

Channel: 7 Mode: g
 Tx Chain: B Data Rate: 6

Power Settings		
Target (dBm)	Measured (dBm)	Software Setting
17.5	17.3	27.0

Frequency MHz	Level dB μ V/m	Pol v/h	15.209 / 15.247		Detector Pk/QP/Avg	Azimuth degrees	Height meters	Comments
			Limit	Margin				
11678.900	39.4	H	54.0	-14.6	AVG	201	1.0	
11667.070	50.8	H	74.0	-23.2	PK	201	1.0	
3000.120	50.1	V	54.0	-3.9	PK	9	1.0	Notes 1, 4
1499.120	43.9	H	54.0	-10.1	AVG	223	1.3	Note 4
1497.850	51.7	H	74.0	-22.3	PK	223	1.3	Note 4
1598.950	34.0	V	54.0	-20.0	AVG	239	1.0	Note 4
1596.580	54.6	V	74.0	-19.4	PK	239	1.0	Note 4

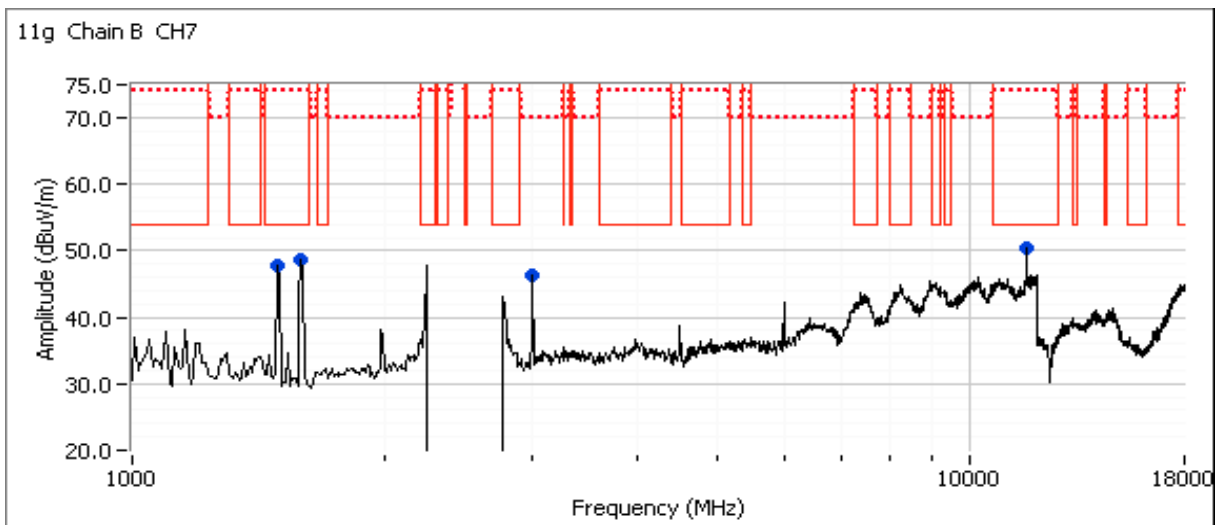



EMC Test Data

Client:	Intel Corporation	Job Number:	J94914
Model:	7265D2W	T-Log Number:	T95471
Contact:	Steve Hackett	Project Manager:	Christine Krebill
Standard:	FCC Part 15.247, 15.407, RSS-210	Project Coordinator:	-
		Class:	N/A

Note: Scans made between 18 - 25 GHz with the measurement antenna moved around the card and its antennas 20-50cm from the device indicated there were no significant emissions in this frequency range

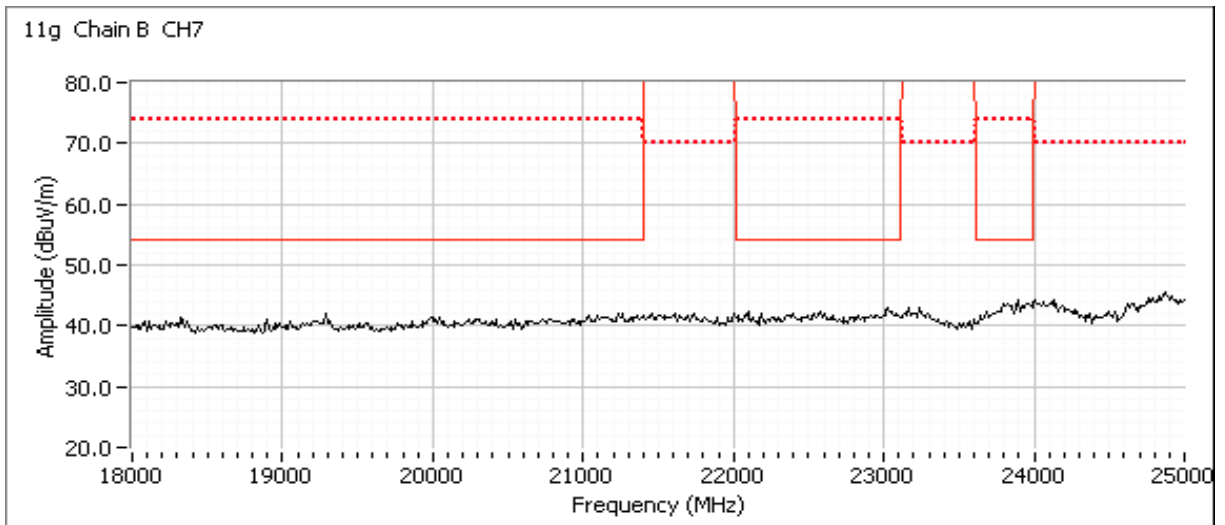



EMC Test Data

Client: Intel Corporation	Job Number: J94914
Model: 7265D2W	T-Log Number: T95471
Contact: Steve Hackett	Project Manager: Christine Krebill
Standard: FCC Part 15.247, 15.407, RSS-210	Project Coordinator: -
	Class: N/A

Run #3c: Center Channel

Channel: 7 Mode: n20
 Tx Chain: A+B Data Rate: HT0

Chain	Power Settings								Software Setting
	Target (dBm)				Measured (dBm)				
	A	B	C	Total	A	B	C	Total	
	17.5	17.5		20.5	17.3	17.4		20.4	23.0, 29.0

Frequency	Level	Pol	15.209 / 15.247		Detector	Azimuth	Height	Comments
MHz	dB μ V/m	v/h	Limit	Margin	Pk/QP/Avg	degrees	meters	
1598.750	33.4	V	54.0	-20.6	AVG	268	1.0	Note 4
1595.680	55.8	V	74.0	-18.2	PK	268	1.0	Note 4
3000.210	49.4	V	54.0	-4.6	PK	9	1.0	Notes 1, 4
1499.110	44.0	H	54.0	-10.0	AVG	219	1.2	Note 4
1497.740	51.3	H	74.0	-22.7	PK	219	1.2	Note 4

Note: Scans made between 18 - 25 GHz with the measurement antenna moved around the card and its antennas 20-50cm from the device indicated there were no significant emissions in this frequency range

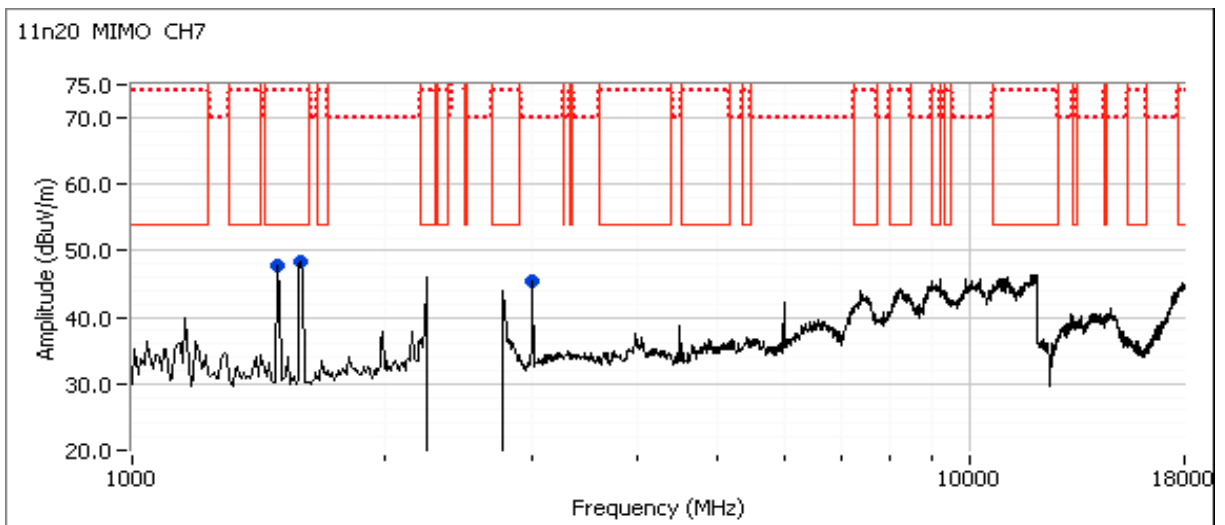



EMC Test Data

Client: Intel Corporation	Job Number: J94914
Model: 7265D2W	T-Log Number: T95471
Contact: Steve Hackett	Project Manager: Christine Krebill
Standard: FCC Part 15.247, 15.407, RSS-210	Project Coordinator: -
	Class: N/A

Run #3d: Center Channel

Channel: 6 Mode: n40
 Tx Chain: A+B Data Rate: HT0

Chain	Power Settings								Software Setting
	Target (dBm)				Measured (dBm)				
	A	B	C	Total	A	B	C	Total	
	16.5	16.5		19.5	16.7	16.7		19.7	23.0, 28.0

Frequency	Level	Pol	15.209 / 15.247		Detector	Azimuth	Height	Comments
MHz	dB μ V/m	v/h	Limit	Margin	Pk/QP/Avg	degrees	meters	
1598.640	35.4	V	54.0	-18.6	AVG	275	1.0	Note 4
1593.840	55.9	V	74.0	-18.1	PK	275	1.0	Note 4
3000.250	48.8	V	54.0	-5.2	PK	7	1.0	Notes 1, 4
1498.970	43.5	H	54.0	-10.5	AVG	219	1.4	Note 4
1498.270	52.2	H	74.0	-21.8	PK	219	1.4	Note 4

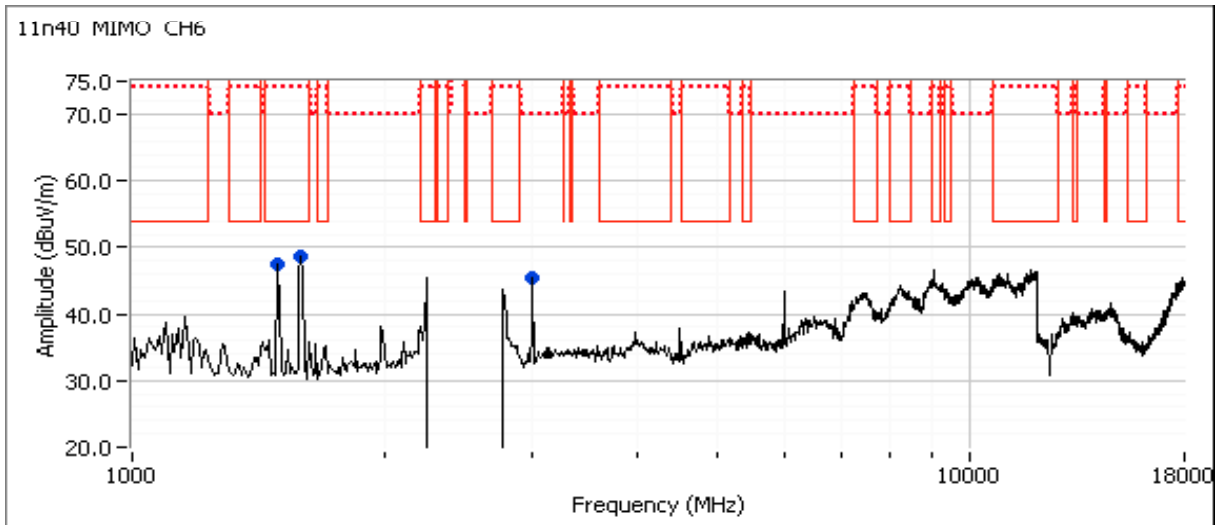



EMC Test Data

Client:	Intel Corporation	Job Number:	J94914
Model:	7265D2W	T-Log Number:	T95471
Contact:	Steve Hackett	Project Manager:	Christine Krebill
Standard:	FCC Part 15.247, 15.407, RSS-210	Project Coordinator:	-
		Class:	N/A

Note: Scans made between 18 - 25 GHz with the measurement antenna moved around the card and its antennas 20-50cm from the device indicated there were no significant emissions in this frequency range

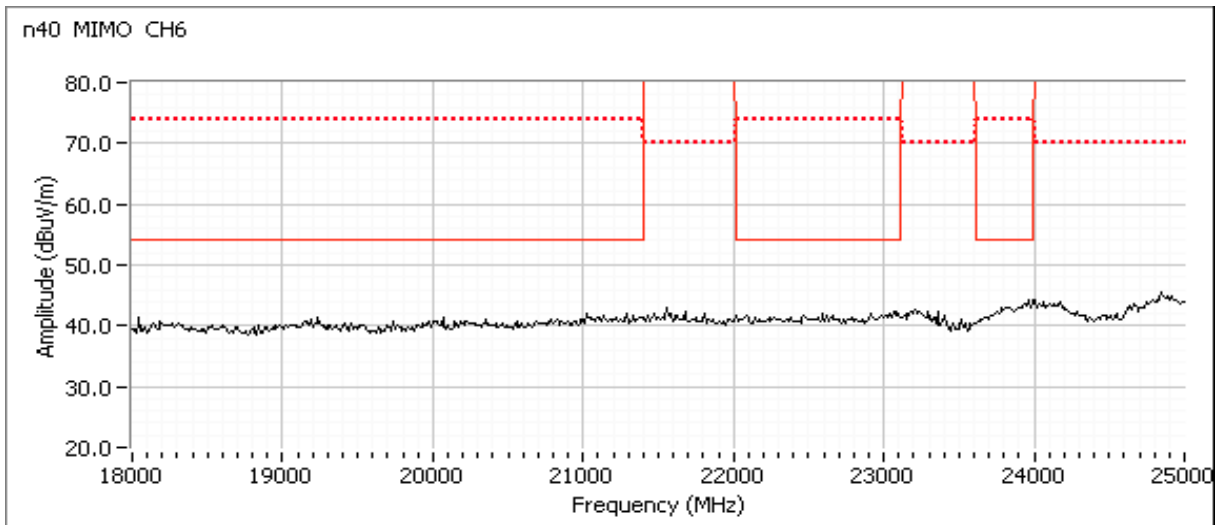



EMC Test Data

Client: Intel Corporation	Job Number: J94914
Model: 7265D2W	T-Log Number: T95471
Contact: Steve Hackett	Project Manager: Christine Krebill
Standard: FCC Part 15.247, 15.407, RSS-210	Project Coordinator: -
	Class: N/A

Run #4: Radiated Spurious Emissions, 1,000 - 25000 MHz. Operating Mode: Worse case from Run #2

Date of Test: 6/12/2014

Config. Used: 1

Test Engineer: Deniz Demirci

Config Change: None

Test Location: FT Ch# 7

EUT Voltage: 3.3 VDC

Run #4a: Low Channel

Channel: 1 Mode: g
Tx Chain: B Data Rate: 6

Power Settings		
Target (dBm)	Measured (dBm)	Software Setting
14.5	14.6	24.0

Frequency MHz	Level dB μ V/m	Pol v/h	15.209 / 15.247		Detector Pk/QP/Avg	Azimuth degrees	Height meters	Comments
			Limit	Margin				
3000.200	46.8	V	54.0	-7.2	AVG	8	1.0	Notes 1, 4
3000.210	49.8	V	74.0	-24.2	PK	8	1.0	Notes 1, 4
4496.730	33.9	V	54.0	-20.1	AVG	266	1.0	Note 4
4498.280	46.5	V	74.0	-27.5	PK	266	1.0	Note 4
1598.910	35.9	V	54.0	-18.1	AVG	268	1.0	Note 4
1592.490	57.8	V	74.0	-16.2	PK	268	1.0	Note 4
1498.890	43.1	H	54.0	-10.9	AVG	210	1.2	Note 4
1499.460	53.6	H	74.0	-20.4	PK	210	1.2	Note 4

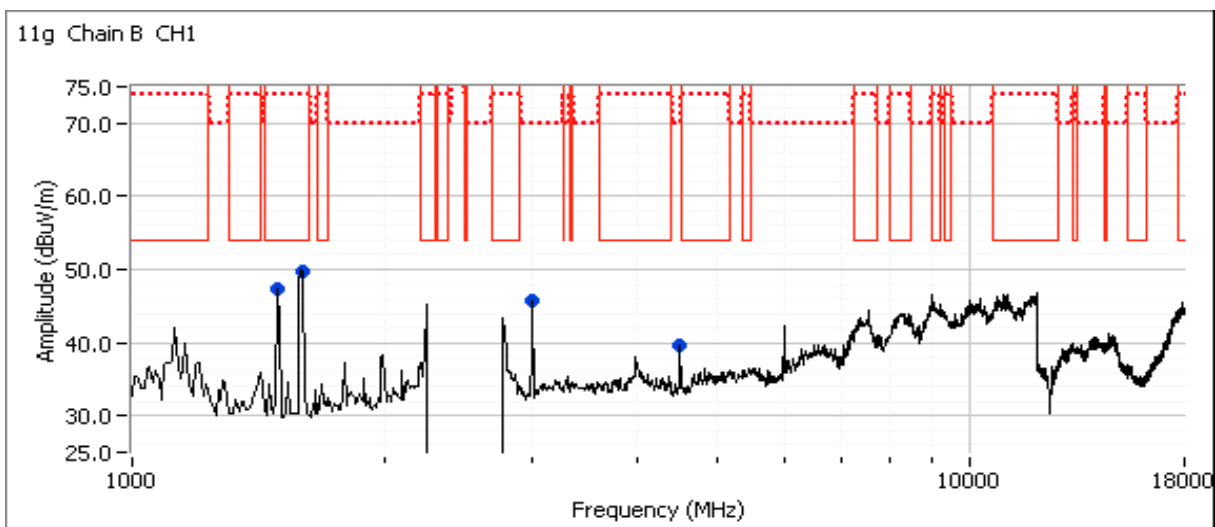



EMC Test Data

Client: Intel Corporation	Job Number: J94914
Model: 7265D2W	T-Log Number: T95471
Contact: Steve Hackett	Project Manager: Christine Krebill
Standard: FCC Part 15.247, 15.407, RSS-210	Project Coordinator: -
	Class: N/A

Run #4b: High Channel

Channel: 11 Mode: g
 Tx Chain: B Data Rate: 6

Power Settings		
Target (dBm)	Measured (dBm)	Software Setting
0.0	0.3	8.0

Frequency MHz	Level dB μ V/m	Pol v/h	15.209 / 15.247		Detector Pk/QP/Avg	Azimuth degrees	Height meters	Comments
			Limit	Margin				
1499.020	44.1	H	54.0	-9.9	AVG	211	1.3	Note 4
1499.030	53.7	H	74.0	-20.3	PK	211	1.3	Note 4
1598.870	34.4	V	54.0	-19.6	AVG	220	1.0	Note 4
1594.070	53.3	V	74.0	-20.7	PK	220	1.0	Note 4
3000.210	47.2	V	54.0	-6.8	AVG	9	1.0	Notes 1, 4
3000.220	50.4	V	74.0	-23.6	PK	9	1.0	Notes 1, 4
4496.880	33.9	V	54.0	-20.1	AVG	279	1.0	Note 4
4497.200	46.5	V	74.0	-27.5	PK	279	1.0	Note 4

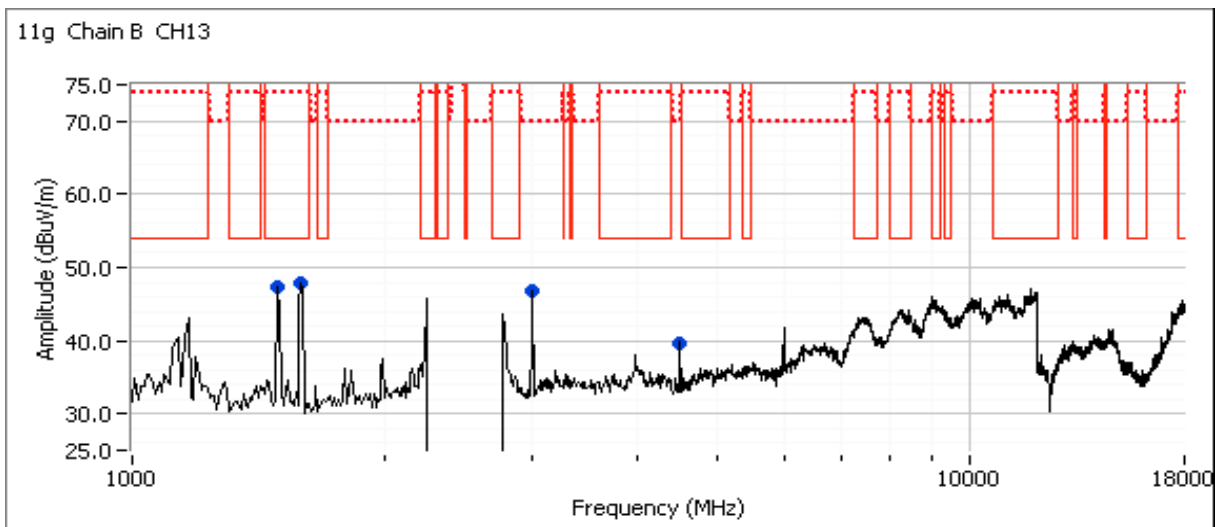



EMC Test Data

Client: Intel Corporation	Job Number: J94914
Model: 7265D2W	T-Log Number: T95471
Contact: Steve Hackett	Project Manager: Christine Krebill
Standard: FCC Part 15.247, 15.407, RSS-210	Project Coordinator: -
	Class: N/A

Run #4c: Low Channel

Channel: 1 Mode: n20
 Tx Chain: A + B Data Rate: HT0

Chain	Target (dBm)				Measured (dBm)				Software Setting
	A	B	C	Total	A	B	C	Total	
	12.0	12.0		15.0	12.2	12.2		15.2	16 / 21.5

Frequency	Level	Pol	15.209 / 15.247		Detector	Azimuth	Height	Comments
MHz	dB μ V/m	v/h	Limit	Margin	Pk/QP/Avg	degrees	meters	
4496.870	33.5	V	54.0	-20.5	AVG	274	1.0	Note 4
4496.870	46.1	V	74.0	-27.9	PK	274	1.0	Note 4
3000.200	47.2	V	54.0	-6.8	AVG	10	1.0	Notes 1, 4
3000.210	50.2	V	74.0	-23.8	PK	10	1.0	Notes 1, 4
1499.010	44.6	H	54.0	-9.4	AVG	212	1.3	Note 4
1499.170	53.0	H	74.0	-21.0	PK	212	1.3	Note 4
1598.650	35.9	V	54.0	-18.1	AVG	269	1.0	Note 4
1596.930	57.6	V	74.0	-16.4	PK	269	1.0	Note 4

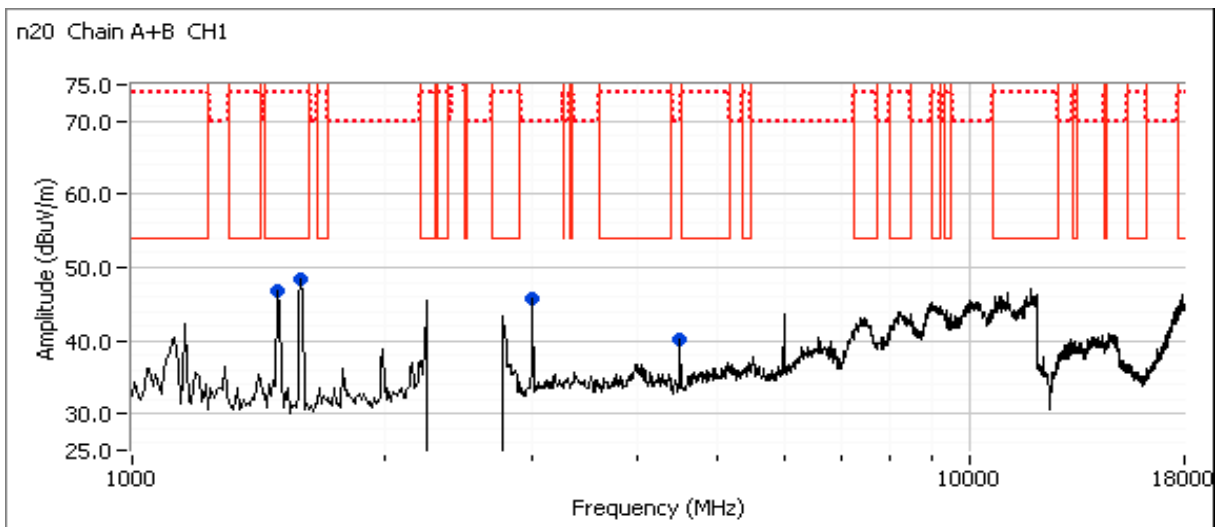



EMC Test Data

Client: Intel Corporation	Job Number: J94914
Model: 7265D2W	T-Log Number: T95471
Contact: Steve Hackett	Project Manager: Christine Krebill
Standard: FCC Part 15.247, 15.407, RSS-210	Project Coordinator: -
	Class: N/A

Run #4d: High Channel

Channel: 11 Mode: n20
 Tx Chain: A + B Data Rate: HT0

Chain	Power Settings								Software Setting
	Target (dBm)				Measured (dBm)				
	A	B	C	Total	A	B	C	Total	
	0.0	0.0		3.0	0.1	0.2		3.2	4 / 8.5

Frequency	Level	Pol	15.209 / 15.247		Detector	Azimuth	Height	Comments
MHz	dB μ V/m	v/h	Limit	Margin	Pk/QP/Avg	degrees	meters	
1598.480	35.3	V	54.0	-18.7	AVG	258	1.0	Note 4
1592.920	55.6	V	74.0	-18.4	PK	258	1.0	Note 4
1499.180	43.5	H	54.0	-10.5	AVG	215	1.4	Note 4
1498.570	52.5	H	74.0	-21.5	PK	215	1.4	Note 4
3000.240	46.9	V	54.0	-7.1	AVG	10	1.0	Notes 1, 4
3000.170	49.9	V	74.0	-24.1	PK	10	1.0	Notes 1, 4
4496.970	33.6	V	54.0	-20.4	AVG	277	1.0	Note 4
4497.330	46.6	V	74.0	-27.4	PK	277	1.0	Note 4

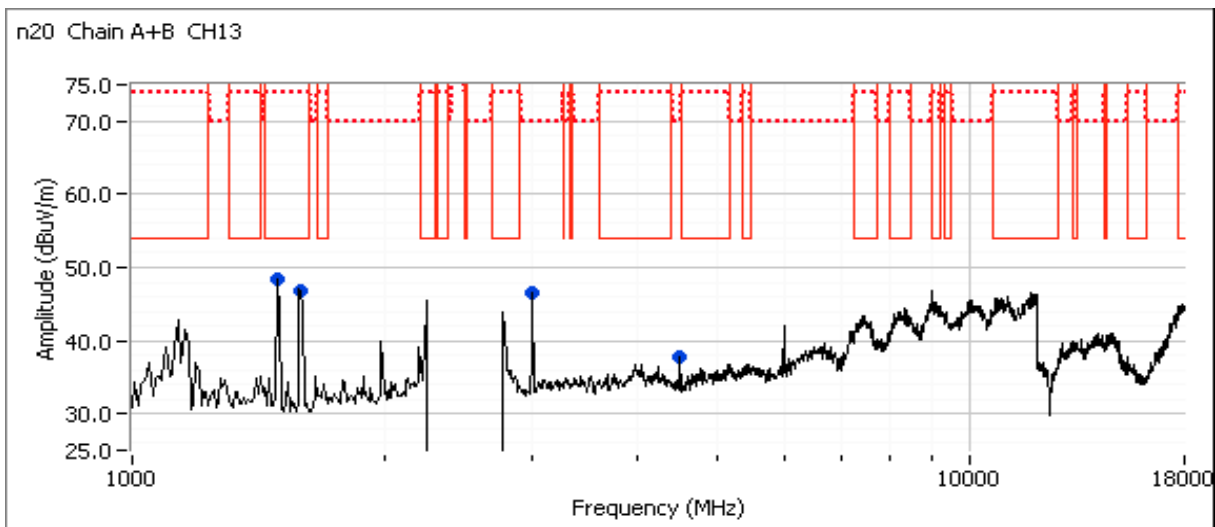

Client:	Intel Corporation	Job Number:	J94914
Model:	7265D2W	T-Log Number:	T95471
Contact:	Steve Hackett	Project Manager:	Christine Krebill
Standard:	FCC Part 15.247, 15.407, RSS-210	Project Coordinator:	-
		Class:	N/A

RSS 210 and FCC 15.247 (DTS) Antenna Port Measurements Power, PSD, Bandwidth and Spurious Emissions

Test Specific Details

Objective: The objective of this test session is to perform final qualification testing of the EUT with respect to the specification listed above.

Date of Test:	6/19/2014	Config. Used:	1
Test Engineer:	John Caizzi Joseph Cadigal	Config Change:	none
Test Location:	Lab 4A	Host Unit Voltage	

General Test Configuration

When measuring the conducted emissions from the EUT's antenna port, the antenna port of the EUT was connected to the spectrum analyzer or power meter via a suitable attenuator to prevent overloading the measurement system. All measurements are corrected to allow for the external attenuators used.

Ambient Conditions:

Temperature:	23 °C
Rel. Humidity:	35 %

Summary of Results

MAC Address: 001500F15B5D DRTU Tool Version 1.7.3-935 Driver version 17.1.0.11

Run #	Pwr setting	Avg Pwr	Test Performed	Limit	Pass / Fail	Result / Margin
1	Default		Output Power	15.247(b)	Pass	3.5 dBm
2			Power spectral Density (PSD)	15.247(d)	Pass	-6.5 dBm/3kHz
3			Minimum 6dB Bandwidth	15.247(a)	Pass	655 kHz
3			99% Bandwidth	RSS GEN	-	1.042 MHz
4				Spurious emissions	15.247(b)	Pass

Modifications Made During Testing

No modifications were made to the EUT during testing

Deviations From The Standard

No deviations were made from the requirements of the standard.



EMC Test Data

Client: Intel Corporation	Job Number: J94914
Model: 7265D2W	T-Log Number: T95471
Contact: Steve Hackett	Project Manager: Christine Krebill
Standard: FCC Part 15.247, 15.407, RSS-210	Project Coordinator: -
	Class: N/A

Run #1: Output Power

Power Setting ²	Frequency (MHz)	Output Power		Antenna Gain (dBi)	Result	EIRP ^{Note 2}		Output Power	
		(dBm) ¹	mW			dBm	W	(dBm) ³	mW
Default	2402	3.5	2.2	3.2	Pass	6.7	0.005		
	2440	3.3	2.1	3.2	Pass	6.5	0.004		
	2480	3.1	2.0	3.2	Pass	6.3	0.004		

- Note 1: Output power measured using a peak power meter, spurious limit is -20dBc.
- Note 2: Power setting - the software power setting used during testing, included for reference only.
- Note 3: Power measured using average power meter and is included for reference only.

Run #2: Power spectral Density

Power Setting	Frequency (MHz)	PSD	Limit	Result
		(dBm/10kHz) ^{Note 1}		
Default	2402	-6.5	8.0	Pass
	2440	-6.6	8.0	Pass
	2480	-6.5	8.0	Pass

Note 1: Test performed per method PKSPD, in KDB 558074. Power spectral density measured using: $3\text{kHz} \leq \text{RBW} \leq 100\text{kHz}$, $\text{VBW}=3*\text{RBW}$, peak detector, span = $1.5*\text{DTS BW}$, auto sweep time, max hold.

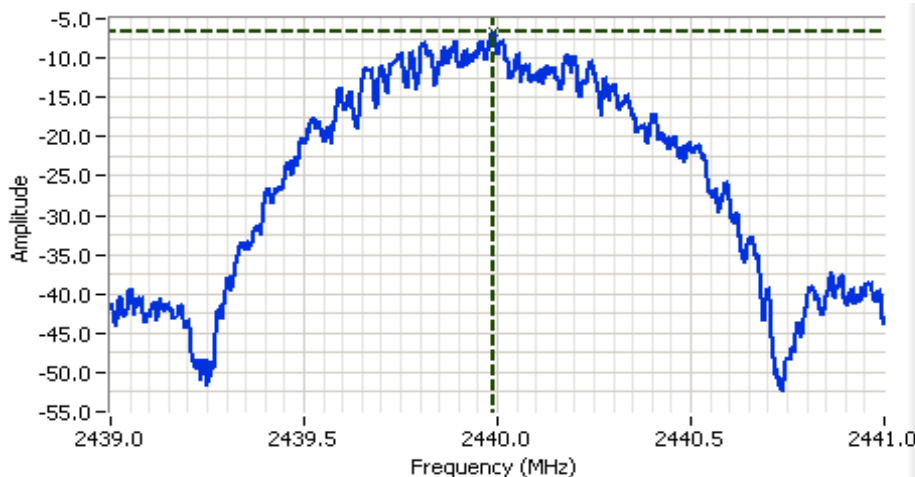

Analyzer Settings
 Agilent Technologies, E4446A
 CF: 2440.000 MHz
 SPAN: 2.000 MHz
 RB: 10.0 kHz
 VB: 30.0 kHz
 Detector: POS
 Attn: 10 DB
 RL Offset: 10.5 DB
 Sweep Time: 19.2ms
 Ref Lvl: 0.0 DBM

Comments
 BT
 PSD = -6.59dBm/10kHz

Cursor 1 2439.9883 -6.59

0.0000 0.00



Client: Intel Corporation	Job Number: J94914
Model: 7265D2W	T-Log Number: T95471
Contact: Steve Hackett	Project Manager: Christine Krebill
Standard: FCC Part 15.247, 15.407, RSS-210	Project Coordinator: -
	Class: N/A

Run #3: Signal Bandwidth

Power Setting	Frequency (MHz)	Resolution Bandwidth	Bandwidth (MHz)	
			6dB	99%
Default	2402	Notes 1 & 2	0.664	1.042
	2440		0.655	1.040
	2480		0.667	1.037

Note 1: 6dB bandwidth measured using RB = 100 kHz, VB = 300 kHz.

Note 2: 99% bandwidth measured using RB = 20 kHz, VB = 62 kHz (VB >=3RB)

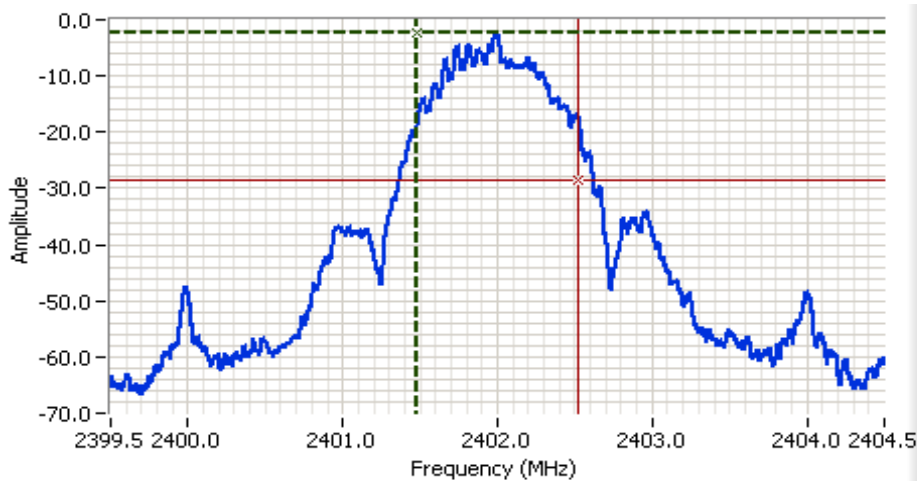

Analyzer Settings
 Agilent Technologies, E4446A
 CF: 2402.000 MHz
 SPAN: 5.000 MHz
 RB: 20.0 kHz
 VB: 62.0 kHz
 Detector: POS
 Attn: 10 DB
 RL Offset: 10.5 DB
 Sweep Time: 12.0ms
 Ref Lvl: 0.0 DBM

Comments
 99% power BW: 1.042 MHz

Cursor 1	2401.4800	-2.41	Delta Freq.	1.042
Cursor 2	2402.5217	-28.41	Delta Amplitude	26.00



EMC Test Data

Client: Intel Corporation	Job Number: J94914
Model: 7265D2W	T-Log Number: T95471
Contact: Steve Hackett	Project Manager: Christine Krebill
Standard: FCC Part 15.247, 15.407, RSS-210	Project Coordinator: -
	Class: N/A

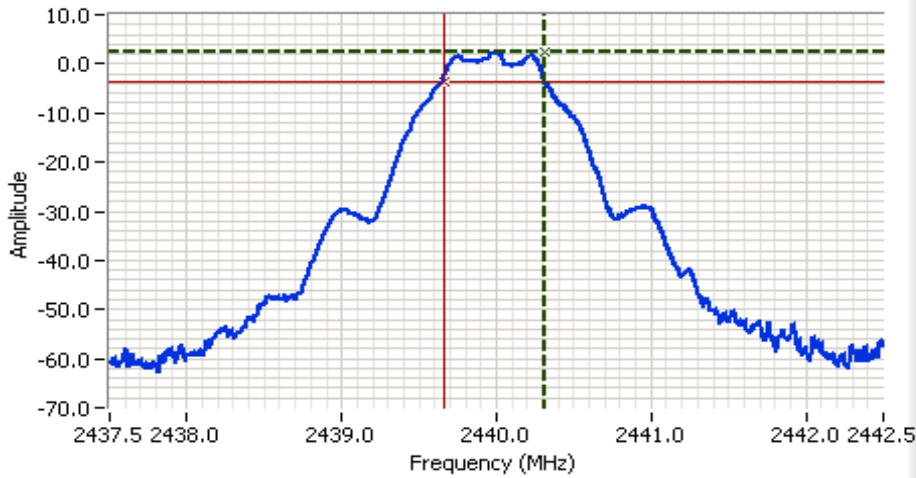

Analyzer Settings

Agilent Technologies, E4446A
 CF: 2440.000 MHz
 SPAN: 5.000 MHz
 RB: 100 kHz
 VB: 300 kHz
 Detector: POS
 Attn: 10 DB
 RL Offset: 10.5 DB
 Sweep Time: 1.0ms
 Ref Lvl: 10.0 DBM

Comments

6dB BW: 655 kHz
 BTLE

Cursor 1 2440.3109 2.40

Cursor 2 2439.6557 -3.60

Delta Freq. 655 kHz

Delta Amplitude 6.00



Client: Intel Corporation	Job Number: J94914
Model: 7265D2W	T-Log Number: T95471
	Project Manager: Christine Krebill
Contact: Steve Hackett	Project Coordinator: -
Standard: FCC Part 15.247, 15.407, RSS-210	Class: N/A

Run #4: Out of Band Spurious Emissions

Frequency (MHz)	Limit	Result
2402	-20dBc	pass
2440	-20dBc	pass
2480	-20dBc	pass

Plots for low channel, power setting = default

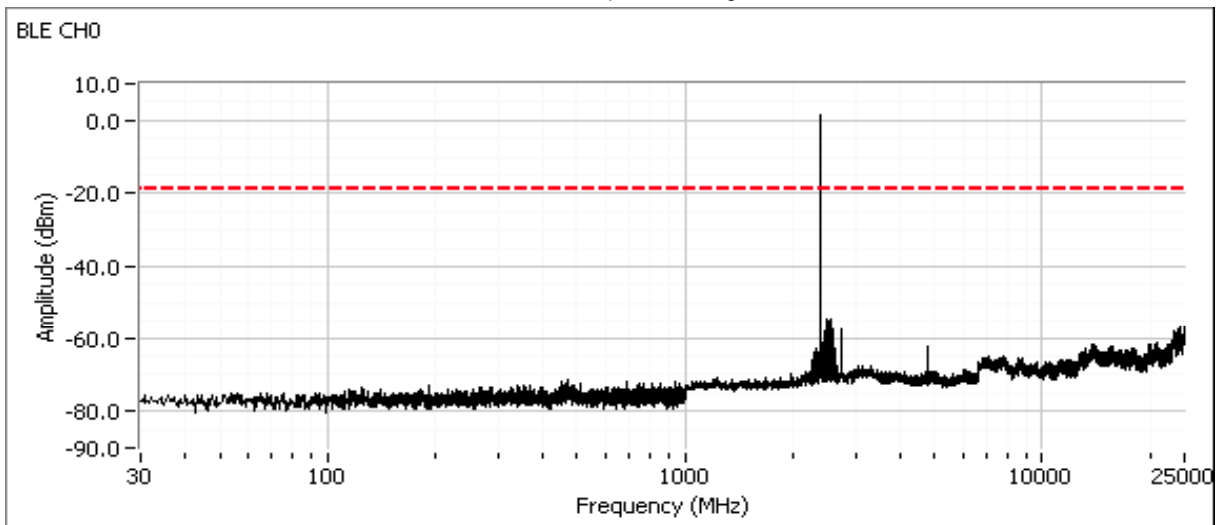

Client:	Intel Corporation	Job Number:	J94914
Model:	7265D2W	T-Log Number:	T95471
Contact:	Steve Hackett	Project Manager:	Christine Krebill
Standard:	FCC Part 15.247, 15.407, RSS-210	Project Coordinator:	-
		Class:	N/A

Additional plot showing compliance with -20dBc limit from 2390 MHz to 2400 MHz. Radiated measurements used to show compliance with the limits in the restricted band below 2390 MHz.

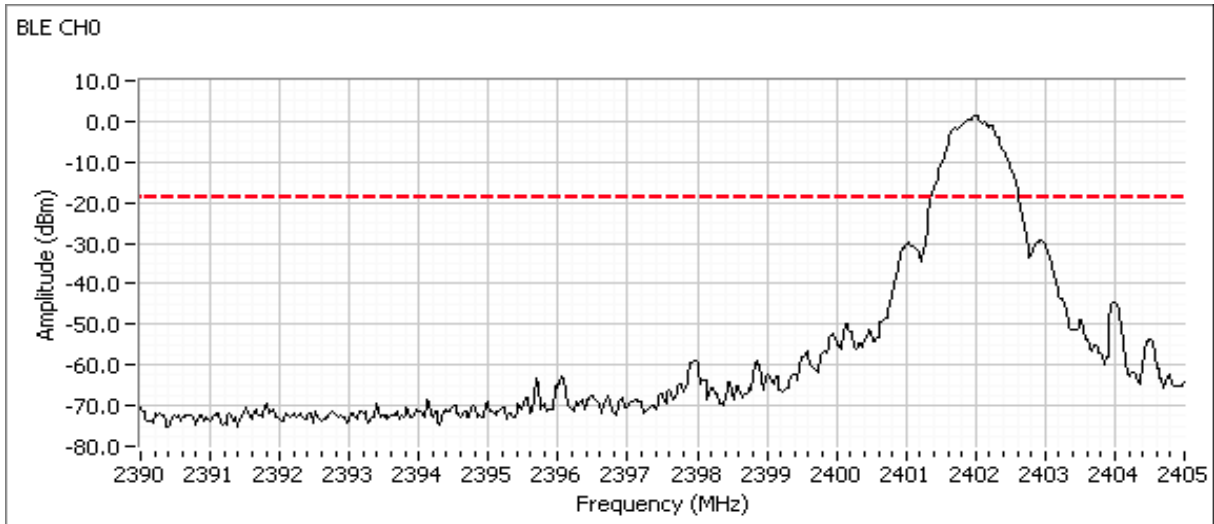

Plots for center channel, power setting = default

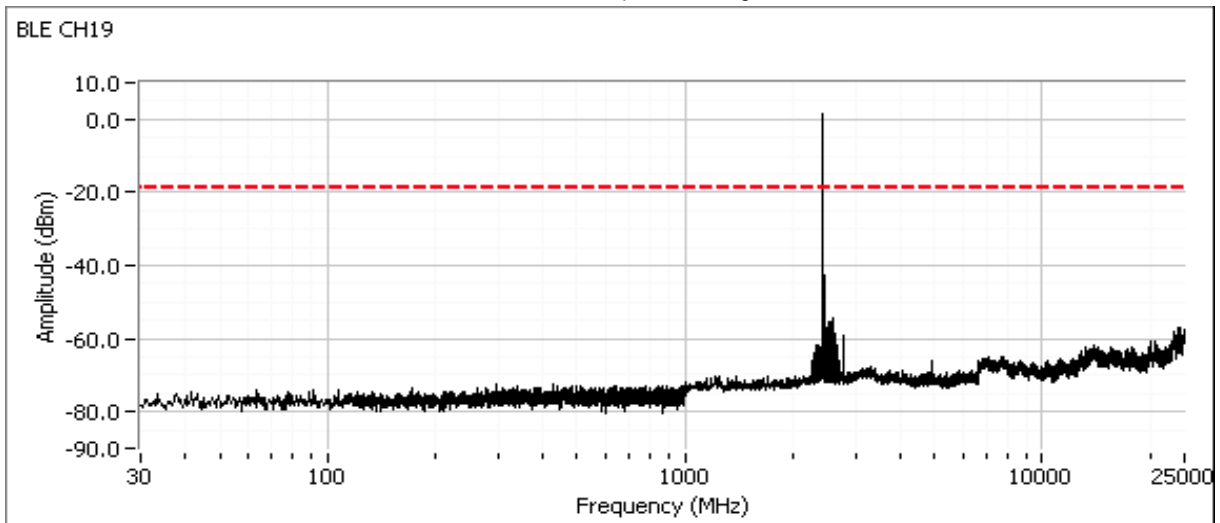

Client: Intel Corporation	Job Number: J94914
Model: 7265D2W	T-Log Number: T95471
	Project Manager: Christine Krebill
Contact: Steve Hackett	Project Coordinator: -
Standard: FCC Part 15.247, 15.407, RSS-210	Class: N/A

Plots for high channel, power setting = default

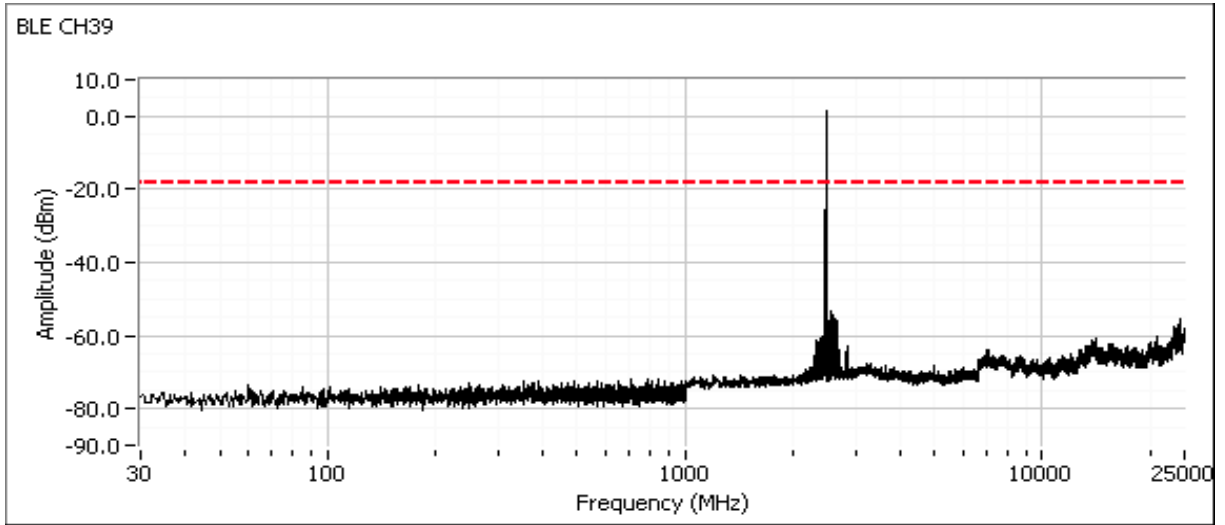

Radiated measurements used to show compliance with the limits in the restricted band above 2483.5 MHz.



EMC Test Data

Client:	Intel Corporation	Job Number:	J94914
Model:	7265D2W	T-Log Number:	T95471
Contact:	Steve Hackett	Project Manager:	Christine Krebill
Standard:	FCC Part 15.247, 15.407, RSS-210	Project Coordinator:	-
		Class:	N/A

RSS 210 and FCC 15.247 (DTS) Radiated Spurious Emissions

Test Specific Details

Objective: The objective of this test session is to perform final qualification testing of the EUT with respect to the specification listed above.

General Test Configuration

The EUT and all local support equipment were located on the turntable for radiated spurious emissions testing. For radiated emissions testing the measurement antenna was located 3 meters from the EUT.

Ambient Conditions:

Temperature: 24 °C
Rel. Humidity: 38 %

Summary of Results - Device Operating in the 2400-2483.5 MHz Band

MAC Address: 001500F15B5D DRTU Tool Version 1.7.3-935 Driver version 17.1.0.11

Run #	Mode	Channel	Power Setting	Measured Power	Test Performed	Limit	Result / Margin
1a	Bluetooth LE	low	Default	3.02	Restricted Band Edge (2390 MHz)	FCC Part 15.209 / 15.247(c)	36.3 dBµV/m @ 2342.1 MHz (-17.7 dB)
					Radiated Emissions, 1 - 26 GHz	FCC Part 15.209 / 15.247(c)	No radio realated emissions
1b		center	Default	3.20	Radiated Emissions, 1 - 26 GHz	FCC Part 15.209 / 15.247(c)	No radio realated emissions
1c		high	Default	3.40	Restricted Band Edge (2483.5 MHz)	FCC Part 15.209 / 15.247(c)	38.2 dBµV/m @ 2485.0 MHz (-15.8 dB)
					Radiated Emissions, 1 - 26 GHz	FCC Part 15.209 / 15.247(c)	No radio realated emissions

Modifications Made During Testing

No modifications were made to the EUT during testing.

Deviations From The Standard

No deviations were made from the requirements of the standard.



EMC Test Data

Client:	Intel Corporation	Job Number:	J94914
Model:	7265D2W	T-Log Number:	T95471
		Project Manager:	Christine Krebill
Contact:	Steve Hackett	Project Coordinator:	-
Standard:	FCC Part 15.247, 15.407, RSS-210	Class:	N/A

Sample Notes

BT Address: 001500F15B61 DRTU Tool Version 1.7.3-935 Driver version 17.1.0.11

Antenna: antenna connected.

Duty Cycle: 0.63

Correction Factor (dB) 4.0



EMC Test Data

Client: Intel Corporation	Job Number: J94914
Model: 7265D2W	T-Log Number: T95471
	Project Manager: Christine Krebill
Contact: Steve Hackett	Project Coordinator: -
Standard: FCC Part 15.247, 15.407, RSS-210	Class: N/A

Run #1: Radiated Spurious Emissions, 1000-26000 MHz. Operating Mode: Low Energy

Date of Test: 6/16/2014 & 6/17/14
 Test Engineer: Jack Liu
 Test Location: FT Chamber7

Run #1a: Low Channel @ 2402 MHz

Chain B	Target (dBm)	Power Settings Measured (dBm)	Software Setting
	-	3.02	Default

Fundamental Signal Field Strength: Peak and average values measured in 1 MHz, and peak value measured in 100kHz

Frequency	Level	Pol	15.209 / 15.247		Detector	Azimuth	Height	Comments
MHz	dB μ V/m	v/h	Limit	Margin	Pk/QP/Avg	degrees	meters	
2401.990	100.5	H	-	-	Pk	192	1.0	POS; RB 100 kHz; VB: 100 kHz
2401.910	95.4	V	-	-	Pk	78	1.0	POS; RB 100 kHz; VB: 100 kHz

Fundamental emission level @ 3m in 100kHz RBW:	100.5	dB μ V/m	
Limit for emissions outside of restricted bands:	80.5	dB μ V/m	Limit is -20dBc (Peak power measurement)
Limit for emissions outside of restricted bands:	70.5	dB μ V/m	Limit is -30dBc (UNII power measurement)

Band Edge Signal Field Strength - Direct measurement of field strength

Frequency	Level	Pol	15.209 / 15.247		Detector	Azimuth	Height	Comments
MHz	dB μ V/m	v/h	Limit	Margin	Pk/QP/Avg	degrees	meters	
2342.060	36.3	H	54.0	-17.7	AVG	60	1.0	Correction Factor (3.96dB) added
2342.870	43.4	H	74.0	-30.6	PK	60	1.0	POS; RB 1 MHz; VB: 3 MHz
2341.900	35.1	V	54.0	-18.9	AVG	71	1.1	POS; RB 1 MHz; VB: 10 Hz
2376.050	42.8	V	74.0	-31.2	PK	71	1.1	POS; RB 1 MHz; VB: 3 MHz

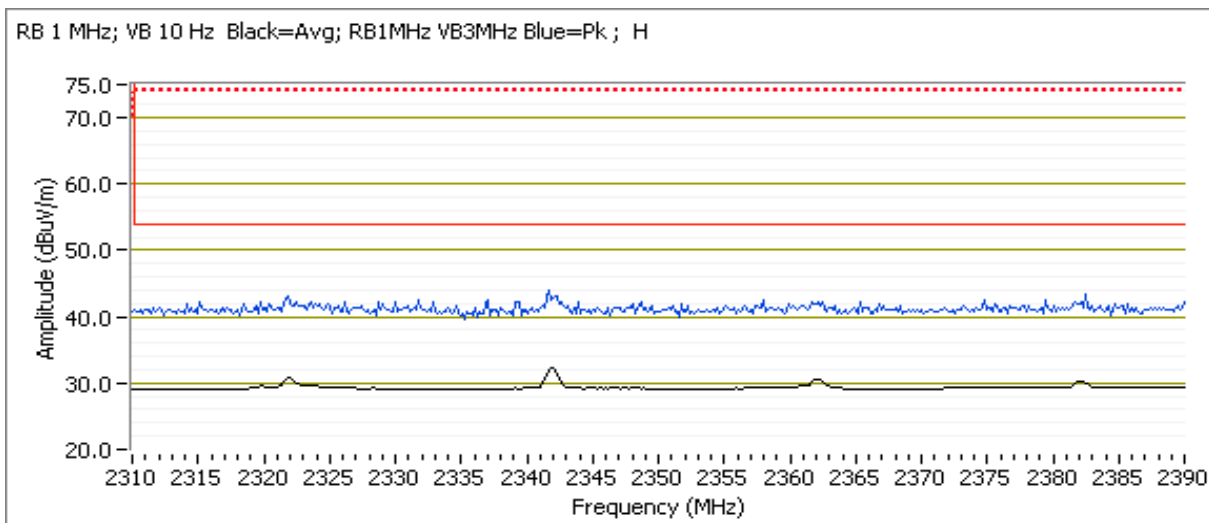



EMC Test Data

Client: Intel Corporation	Job Number: J94914
Model: 7265D2W	T-Log Number: T95471
Contact: Steve Hackett	Project Manager: Christine Krebill
Standard: FCC Part 15.247, 15.407, RSS-210	Project Coordinator: -
	Class: N/A

Other Spurious Emissions

Frequency MHz	Level dB μ V/m	Pol v/h	15.209 / 15.247		Detector Pk/QP/Avg	Azimuth degrees	Height meters	Comments
			Limit	Margin				
1499.000	43.5	H	54.0	-10.5	AVG	209	1.3	Note 3
1496.470	51.1	H	74.0	-22.9	PK	209	1.3	Note 3
1598.470	39.0	V	54.0	-15.0	AVG	267	1.0	Note 3
1600.070	60.2	V	74.0	-13.8	PK	267	1.0	Note 3
4496.930	39.4	V	54.0	-14.6	AVG	272	1.0	Note 2, 3
4497.130	51.5	V	74.0	-22.5	PK	272	1.0	Note 2, 3
3000.070	46.5	V	54.0	-7.5	AVG	268	1.0	Note 2, 3
2999.940	50.4	V	74.0	-23.6	PK	268	1.0	Note 2, 3

- Note 1: For emissions in restricted bands, the limit of 15.209 was used. For all other emissions, the limit was set 20dB below the level of the fundamental and measured in 100kHz.
- Note 2: Signal is not in a restricted band but the more stringent restricted band limit was used.
- Note 3: Not radio related. See notes for 2.4GHz Wifi Spurious RE.
- Note 4: Scans made between 18 - 26GHz with the measurement antenna moved around the card and its antennas 20-50cm from the device indicated there were no significant emissions in this frequency range

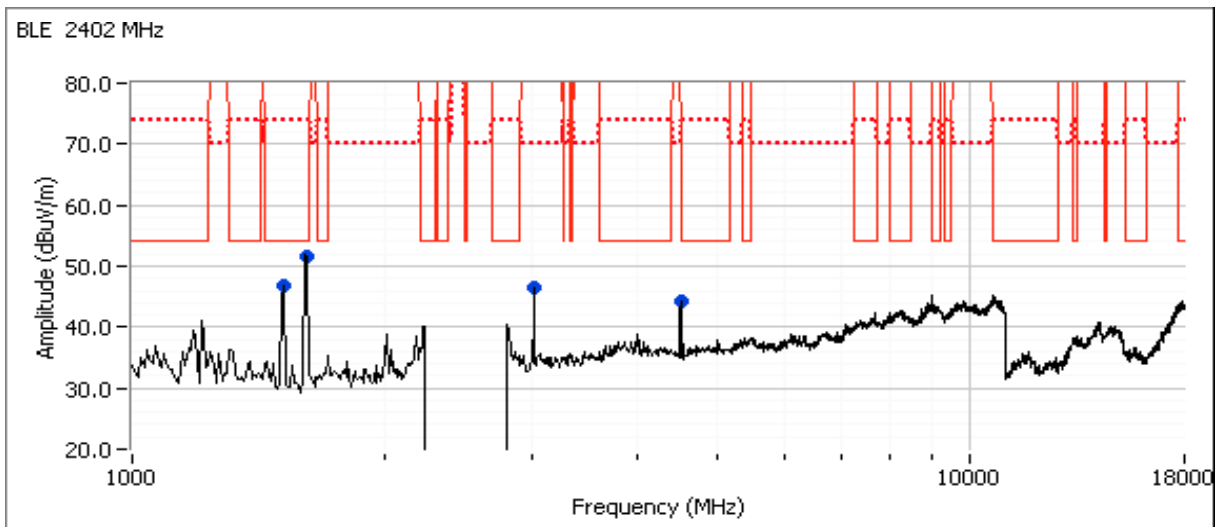



EMC Test Data

Client: Intel Corporation	Job Number: J94914
Model: 7265D2W	T-Log Number: T95471
	Project Manager: Christine Krebill
Contact: Steve Hackett	Project Coordinator: -
Standard: FCC Part 15.247, 15.407, RSS-210	Class: N/A

Run #1b: Center Channel @ 2440 MHz

	Target (dBm)	Power Settings Measured (dBm)	Software Setting
Chain B	-	3.20	Default

Note - measured power in table above is average power, for reference only.

Fundamental Signal Field Strength: Peak value measured in 100kHz

Frequency	Level	Pol	15.209 / 15.247		Detector	Azimuth	Height	Comments
MHz	dB μ V/m	v/h	Limit	Margin	Pk/QP/Avg	degrees	meters	
2439.930	100.6	H	-	-	Pk	191	1.0	POS; RB 100 kHz; VB: 100 kHz
2439.970	94.0	V	-	-	Pk	88	1.0	POS; RB 100 kHz; VB: 100 kHz

Fundamental emission level @ 3m in 100kHz RBW:	100.6	dB μ V/m	
Limit for emissions outside of restricted bands:	80.6	dB μ V/m	Limit is -20dBc (Peak power measurement)
Limit for emissions outside of restricted bands:	70.6	dB μ V/m	Limit is -30dBc (UNII power measurement)

Other Spurious Emissions

Frequency	Level	Pol	15.209 / 15.247		Detector	Azimuth	Height	Comments
MHz	dB μ V/m	v/h	Limit	Margin	Pk/QP/Avg	degrees	meters	
1498.940	44.0	H	54.0	-10.0	AVG	208	1.3	Note 3
1497.140	52.5	H	74.0	-21.5	PK	208	1.3	Note 3
1593.860	40.6	V	54.0	-13.4	AVG	274	1.0	Note 3
1597.330	59.4	V	74.0	-14.6	PK	274	1.0	Note 3
3000.140	45.9	V	54.0	-8.1	AVG	264	1.0	Note 2, 3
3000.140	50.5	V	74.0	-23.5	PK	264	1.0	Note 2, 3
4496.960	39.8	V	54.0	-14.2	AVG	268	1.0	Note 2, 3
4496.230	50.6	V	74.0	-23.4	PK	268	1.0	Note 2, 3

Note 1:	For emissions in restricted bands, the limit of 15.209 was used. For all other emissions, the limit was set 20dB below the level of the fundamental and measured in 100kHz.
Note 2:	Signal is not in a restricted band but the more stringent restricted band limit was used.
Note 3:	Not radio related. See notes for 2.4GHz Wifi Spurious RE.
Note 4	Scans made between 18 - 26GHz with the measurement antenna moved around the card and its antennas 20-50cm from the device indicated there were no significant emissions in this frequency range

Client: Intel Corporation	Job Number: J94914
Model: 7265D2W	T-Log Number: T95471
	Project Manager: Christine Krebill
Contact: Steve Hackett	Project Coordinator: -
Standard: FCC Part 15.247, 15.407, RSS-210	Class: N/A

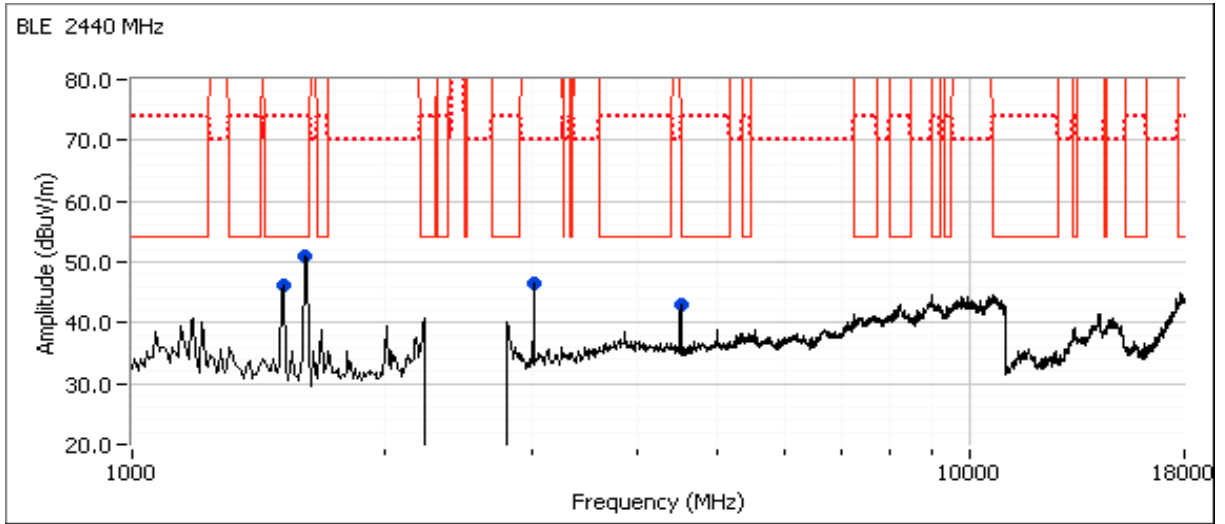



EMC Test Data

Client: Intel Corporation	Job Number: J94914
Model: 7265D2W	T-Log Number: T95471
Contact: Steve Hackett	Project Manager: Christine Krebill
Standard: FCC Part 15.247, 15.407, RSS-210	Project Coordinator: -
	Class: N/A

Run #1c: High Channel @ 2480 MHz

	Target (dBm)	Power Settings Measured (dBm)	Software Setting
Chain B	-	3.40	Default

Note - measured power in table above is average power, for reference only.

Fundamental Signal Field Strength: Peak value measured in 100kHz

Frequency	Level	Pol	15.209 / 15.247		Detector	Azimuth	Height	Comments
MHz	dB μ V/m	v/h	Limit	Margin	Pk/QP/Avg	degrees	meters	
2480.010	98.6	H	-	-	Pk	192	1.0	POS; RB 100 kHz; VB: 100 kHz
2479.950	94.4	V	-	-	Pk	92	1.0	POS; RB 100 kHz; VB: 100 kHz

Fundamental emission level @ 3m in 100kHz RBW:	98.6	dB μ V/m	
Limit for emissions outside of restricted bands:	78.6	dB μ V/m	Limit is -20dBc (Peak power measurement)
Limit for emissions outside of restricted bands:	68.6	dB μ V/m	Limit is -30dBc (UNII power measurement)

Band Edge Signal Field Strength - Direct measurement of field strength

Frequency	Level	Pol	15.209 / 15.247		Detector	Azimuth	Height	Comments
MHz	dB μ V/m	v/h	Limit	Margin	Pk/QP/Avg	degrees	meters	
2484.990	38.2	H	54.0	-15.8	AVG	189	1.0	POS; RB 1 MHz; VB: 10 Hz
2484.530	56.1	H	74.0	-17.9	PK	189	1.0	POS; RB 1 MHz; VB: 3 MHz
2485.020	36.5	V	54.0	-17.5	AVG	90	1.0	POS; RB 1 MHz; VB: 10 Hz
2484.660	52.4	V	74.0	-21.6	PK	90	1.0	POS; RB 1 MHz; VB: 3 MHz

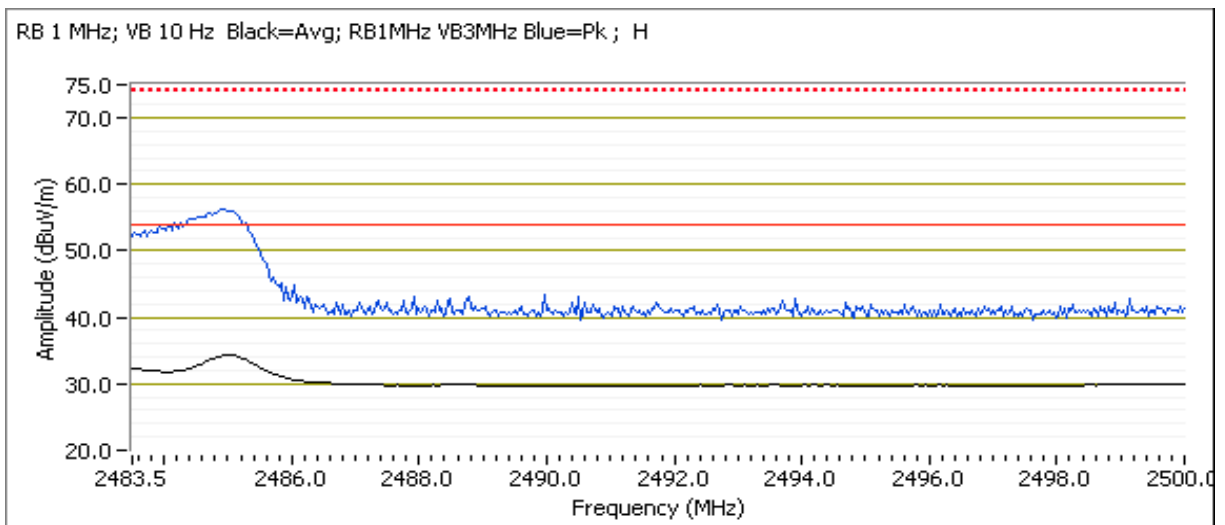



EMC Test Data

Client:	Intel Corporation	Job Number:	J94914
Model:	7265D2W	T-Log Number:	T95471
Contact:	Steve Hackett	Project Manager:	Christine Krebill
Standard:	FCC Part 15.247, 15.407, RSS-210	Project Coordinator:	-
		Class:	N/A

Other Spurious Emissions

Frequency MHz	Level dB μ V/m	Pol v/h	15.209 / 15.247		Detector PK/QP/Avg	Azimuth degrees	Height meters	Comments
			Limit	Margin				
1499.140	44.0	H	54.0	-10.0	AVG	206	1.3	Note 3
1499.240	52.9	H	74.0	-21.1	PK	206	1.3	Note 3
1598.760	40.9	V	54.0	-13.1	AVG	263	1.0	Note 3
1592.460	60.2	V	74.0	-13.8	PK	263	1.0	Note 3
3000.150	46.3	V	54.0	-7.7	AVG	326	1.0	Note 2, 3
3000.190	50.7	V	74.0	-23.3	PK	326	1.0	Note 2, 3
4497.060	40.2	V	54.0	-13.8	AVG	272	1.0	Note 2, 3
4496.200	51.7	V	74.0	-22.3	PK	272	1.0	Note 2, 3

- Note 1: For emissions in restricted bands, the limit of 15.209 was used. For all other emissions, the limit was set 20dB below the level of the fundamental and measured in 100kHz.
- Note 2: Signal is not in a restricted band but the more stringent restricted band limit was used.
- Note 3: Not radio related. See notes for 2.4GHz Wifi Spurious RE.
- Note 4: Scans made between 18 - 26GHz with the measurement antenna moved around the card and its antennas 20-50cm from the device indicated there were no significant emissions in this frequency range

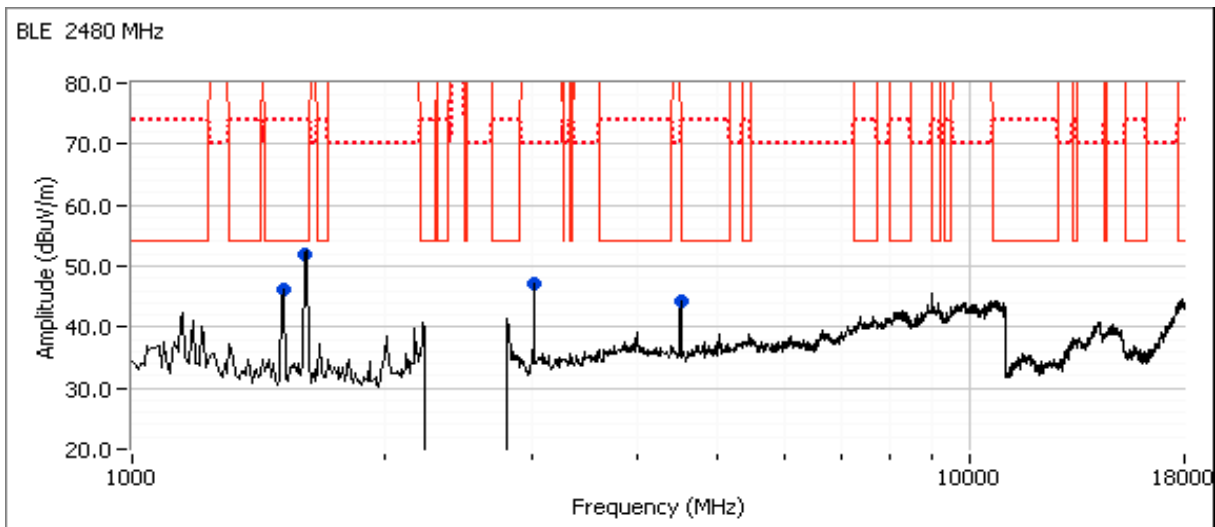



EMC Test Data

Client:	Intel Corporation	Job Number:	J94914
Product:	7265D2W	T-Log Number:	T95472
		Project Manager:	Christine Krebill
Contact:	Steve Hackett	Project Coordinator:	-
Emissions Standard(s):	FCC Part 15.247, 15.407, RSS-210	Class:	B
Immunity Standard(s):	-	Environment:	Radio

EMC Test Data

For The

Intel Corporation

Product

7265D2W

Date of Last Test: 7/8/2014



EMC Test Data

Client:	Intel Corporation	Job Number:	J94914
Model:	7265D2W	T-Log Number:	T95472
Contact:	Steve Hackett	Project Manager:	Christine Krebill
Standard:	FCC Part 15.247, 15.407, RSS-210	Project Coordinator:	-
		Class:	N/A

RSS 210 and FCC 15.247 (DTS) Radiated Spurious Emissions

Test Specific Details

Objective: The objective of this test session is to perform final qualification testing of the EUT with respect to the specification listed above.

General Test Configuration

The EUT and all local support equipment were located on the turntable for radiated spurious emissions testing. For radiated emissions testing the measurement antenna was located 3 meters from the EUT.

For Bluetooth: Tx is chain B, Rx is chain B. **For WiFi,** only Chain A is used for transmit in the 2.4GHz band when Bluetooth is active, both chains can be used in 5GHz bands.

Ambient Conditions:

Temperature: 24 °C
Rel. Humidity: 39 %

Summary of Results

MAC Address: 001500F15B3A DRTU Tool Version 1.7.3-935 Driver version 17.1.0.11

Run #	Mode	Channel	Power Setting	Measured Power	Test Performed	Limit	Result / Margin
1	BT 1Mb/s 802.11b	2402MHz 2412MHz	10 14.5	4.8 17.6	Radiated Emissions 1- 10 GHz	FCC 15.247	56.8 dBµV/m @ 1199.1 MHz (-17.2 dB)
2	BT 1Mb/s 802.11b	2480MHz 2462MHz	10 14.0	5.0 17.7		FCC 15.247	43.5 dBµV/m @ 4924.0 MHz (-10.5 dB)
3	BT 1Mb/s 802.11g	2402MHz 2412MHz	10 20.5	4.8 17.7		FCC 15.247	56.3 dBµV/m @ 1196.0 MHz (-17.7 dB)
4	BT 1Mb/s 802.11g	2480MHz 2462MHz	10 19.5	5.0 17.5		FCC 15.247	53.3 dBµV/m @ 1198.7 MHz (-20.7 dB)



EMC Test Data

Client:	Intel Corporation	Job Number:	J94914
Model:	7265D2W	T-Log Number:	T95472
Contact:	Steve Hackett	Project Manager:	Christine Krebill
Standard:	FCC Part 15.247, 15.407, RSS-210	Project Coordinator:	-
		Class:	N/A

Run #	Mode	Channel	Power Setting	Measured Power	Test Performed	Limit	Result / Margin
WiFi mode for the following runs based on worst case mode from runs 1 through 4							
5	BT 1Mb/s 802.11b	2402MHz 2437MHz	10 14	4.8 17.7	Radiated Emissions 1- 10 GHz	FCC 15.247	46.1 dBµV/m @ 2366.1 MHz (-7.9 dB)
6	BT 1Mb/s 802.11b	2440MHz 2412MHz	10 14.5	5.1 17.6		FCC 15.247	41.9 dBµV/m @ 2356.8 MHz (-12.1 dB)
7	BT 1Mb/s 802.11b	2440MHz 2462MHz	10 14	5.1 17.7	Radiated Emissions 1- 10 GHz	FCC 15.247	41.3 dBµV/m @ 4924.0 MHz (-12.7 dB)
8	BT 1Mb/s 802.11b	2480MHz 2437MHz	10 14	5.0 17.7		FCC 15.247	41.1 dBµV/m @ 4874.0 MHz (-12.9 dB)
WiFi mode and channel and Bluetooth channel based on the worst case mode from runs 1 through 8							
9	BT 3Mb/s 802.11b	2440 MHz 2462 MHz	6 14	1.2 17.7	Radiated Emissions 1- 10 GHz	FCC 15.247	41.4 dBµV/m @ 4924.0 MHz (-12.6 dB)
10	BTLE 802.11b	2440 MHz 2462 MHz	Default 14	3.2 17.7		FCC 15.247	43.5 dBµV/m @ 4924.0 MHz (-10.5 dB)
WiFi mode - 802.11n 20MHz with both chains active at 16.5 dBm per chain, center channel in each 5GHz band. Bluetooth on center channel, 1Mb/s mode							
11	BT 1Mb/s 802.11n20	2440MHz 5200MHz	10 31.0 / 32.0	5.1 16.6 / 16.5	Radiated Emissions 1- 15 GHz	FCC 15.247	No intermodulation founded Other Emissions refer to the spurious RE results
12	BT 1Mb/s 802.11n20	2440MHz 5300MHz	10 32.0 / 33.0	5.1 16.6 / 16.5		FCC 15.247	No intermodulation founded Other Emissions refer to the spurious RE results
13	BT 1Mb/s 802.11n20	2440MHz 5580MHz	10 28.5 / 29.5	5.1 16.5 / 16.6		FCC 15.247	No intermodulation founded Other Emissions refer to the spurious RE results
14	BT 1Mb/s 802.11n20	2440MHz 5785MHz	10 34.5 / 35.5	5.1 16.7 / 16.5		FCC 15.247	No intermodulation founded Other Emissions refer to the spurious RE results



EMC Test Data

Client:	Intel Corporation	Job Number:	J94914
Model:	7265D2W	T-Log Number:	T95472
Contact:	Steve Hackett	Project Manager:	Christine Krebill
Standard:	FCC Part 15.247, 15.407, RSS-210	Project Coordinator:	-
		Class:	N/A

Modifications Made During Testing

No modifications were made to the EUT during testing

Deviations From The Standard

No deviations were made from the requirements of the standard.

Notes:

Bluetooth uses a frequency hopping algorithm that means that the device, during normal operation, is only on a specific channel for a short period of time. The average correction factor is calculated as follows:

A maximum length packet has a duration of 5 time slots.

The hopping rate is 1600 hops/second so the maximum dwell time is 5/1600 seconds, or 3.125ms.

With a minimum of 20 hopping channels a channel will not be used more than 4 times in any 100ms period.

The maximum dwell time in a 100ms period is $4 \times 3.125\text{ms} = 12.5\text{ms}$.

The average correction factor is, therefore, $20\log(12.5/100) = -18\text{dB}$

As this is a hopping radio this correction factor can be applied to the average value of the signal provided the average value was measured with the device continuously transmitting. DA 00-0705 permits the use of the average correction on the **measured average** value for frequency hopping radios.

All measurements in this data sheet do not include the average correction factor.

Antenna: Skycross WiMax/WLAN



EMC Test Data

Client: Intel Corporation	Job Number: J94914
Model: 7265D2W	T-Log Number: T95472
	Project Manager: Christine Krebill
Contact: Steve Hackett	Project Coordinator: -
Standard: FCC Part 15.247, 15.407, RSS-210	Class: N/A

Run #1: 1-10GHz, 802.11b @ 2412 MHz Chain A, BT Basic Rate @ 2402 MHz Chain B
 Date of Test: 6/18/2014 Test Location: FT Chamber #4
 Test Engineer: Jack Liu Config Change: None

	Target (dBm)	Power Settings Measured (dBm)	Software Setting
Chain A	16.5	17.6	14.5
Chain B	-	4.8	10.0

Note - measured power in table above is average power, for reference only.

Perform normal 1-10 GHz scan with filter for fundamental and then 2-3 GHz scan 20-30 cm from the product without filter.

Preliminary Measurements (Peak versus average limit)

Frequency	Level	Pol	15.209/15.247		Detector	Azimuth	Height	Comments
MHz	dB μ V/m	v/h	Limit	Margin	Pk/QP/Avg	degrees	meters	
1200.000	46.6	V	54.0	-7.4	Peak	220	1.0	
1825.000	52.6	V	70.0	-17.4	Peak	60	2.2	
1591.670	42.4	V	54.0	-11.6	Peak	260	1.6	

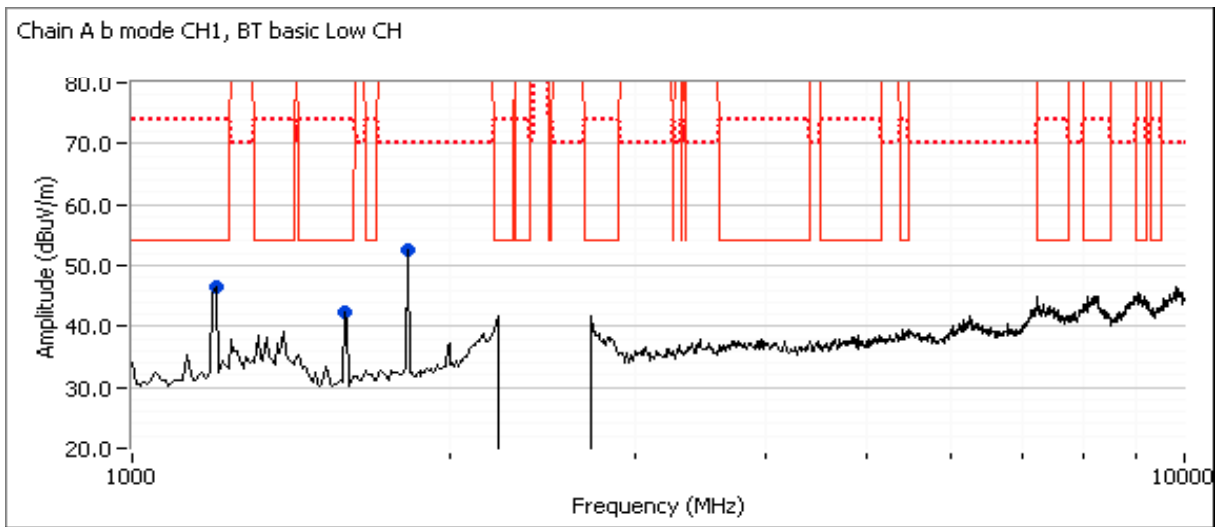



EMC Test Data

Client:	Intel Corporation	Job Number:	J94914
Model:	7265D2W	T-Log Number:	T95472
Contact:	Steve Hackett	Project Manager:	Christine Krebill
Standard:	FCC Part 15.247, 15.407, RSS-210	Project Coordinator:	-
		Class:	N/A

Spurious Emissions excluding allocated band (final measurements at 3m)

Frequency MHz	Level dB μ V/m	Pol v/h	15.209 / 15.247		Detector PK/QP/Avg	Azimuth degrees	Height meters	Comments
			Limit	Margin				
1196.800	31.4	V	54.0	-22.6	AVG	237	1.0	RB 1 MHz;VB 10 Hz;Peak
1199.130	56.8	V	74.0	-17.2	PK	237	1.0	RB 1 MHz;VB 3 MHz;Peak
1819.800	27.3	V	54.0	-26.7	AVG	195	1.9	Note 2
1819.600	39.2	V	74.0	-34.8	PK	195	1.9	Note 2
1594.340	31.2	V	54.0	-22.8	AVG	61	1.6	RB 1 MHz;VB 10 Hz;Peak
1594.940	47.0	V	74.0	-27.0	PK	61	1.6	RB 1 MHz;VB 3 MHz;Peak

Preliminary Measurements (Peak versus average limit) at 20-30cm from EUT

Frequency MHz	Level dB μ V/m	Pol v/h	15.209/15.247		Detector PK/QP/Avg	Azimuth degrees	Height meters	Comments
			Limit	Margin				
2460.920	55.9	H	-	-	Peak	180	1.0	In band intermittent signal
2573.150	43.6	H	54.0	-10.4	Peak	180	1.0	Note 2

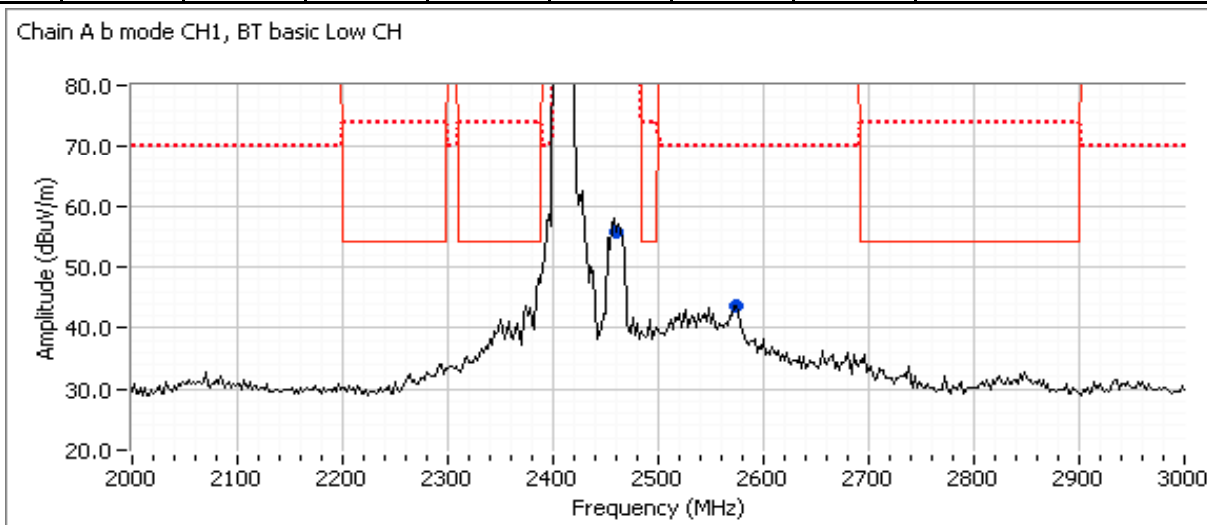

Spurious Emissions near allocated band (final measurements at 3m)

Frequency MHz	Level dB μ V/m	Pol v/h	15.209 / 15.247		Detector PK/QP/Avg	Azimuth degrees	Height meters	Comments
			Limit	Margin				
2573.150	43.6	H	54.0	-10.4	Peak	180	1.0	Note 2

No intermodulation founded

- Note 1: For emissions in restricted bands, the limit of 15.209 was used. For all other emissions, the limit was set 20dB below the level of the fundamental and measured in 100kHz.
- Note 2: Signal is not in a restricted band but the more stringent restricted band limit was used.
- Note 3: Signal is only present when Bluetooth is enabled, average correction for hopping occupancy could be applied



EMC Test Data

Client:	Intel Corporation	Job Number:	J94914
Model:	7265D2W	T-Log Number:	T95472
Contact:	Steve Hackett	Project Manager:	Christine Krebill
Standard:	FCC Part 15.247, 15.407, RSS-210	Project Coordinator:	-
		Class:	N/A

Run #2: 1-10GHz, 802.11b @ 2462 MHz Chain A, BT Basic Rate @ 2480 MHz Chain B
 Date of Test: 6/18/2014 Test Location: FT Chamber #4
 Test Engineer: Jack Liu / R. Varelas Config Change: None

	Target (dBm)	Power Settings Measured (dBm)	Software Setting
Chain A	16.5	17.7	14.0
Chain B	-	5.0	10.0

Note - measured power in table above is average power, for reference only.

Perform normal 1-10 GHz scan with filter for fundamental and then 2-3 GHz scan 20-30 cm from the product without filter.

Preliminary Measurements (Peak versus average limit)

Frequency	Level	Pol	15.209/15.247		Detector	Azimuth	Height	Comments
MHz	dB μ V/m	v/h	Limit	Margin	PK/QP/Avg	degrees	meters	
1191.670	43.8	H	54.0	-10.2	Peak	113	1.5	
1591.670	38.7	V	54.0	-15.3	Peak	126	2.0	
4925.000	46.2	V	54.0	-7.8	Peak	143	1.5	

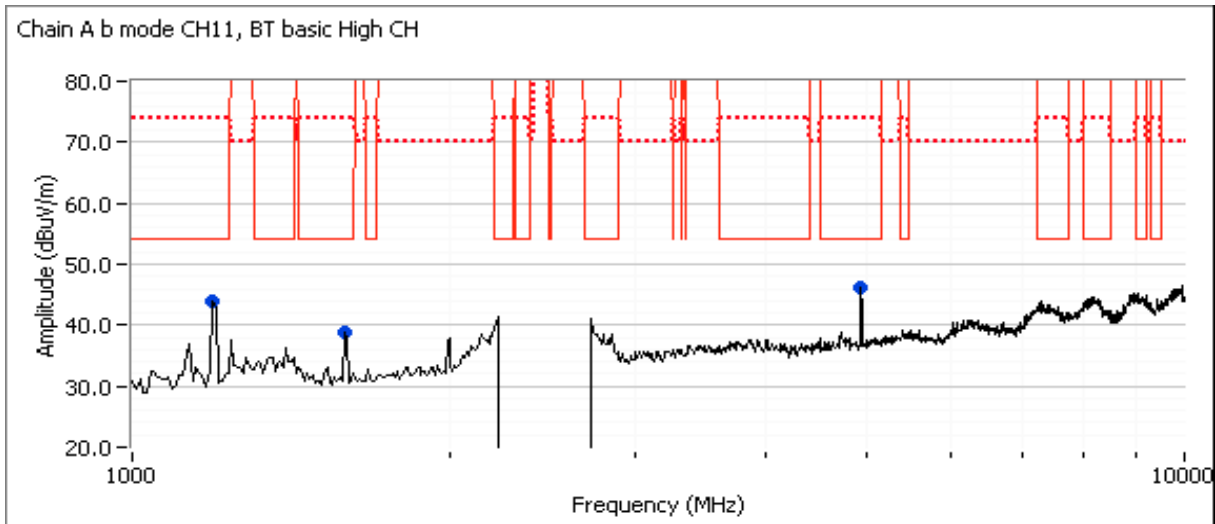



EMC Test Data

Client:	Intel Corporation	Job Number:	J94914
Model:	7265D2W	T-Log Number:	T95472
Contact:	Steve Hackett	Project Manager:	Christine Krebill
Standard:	FCC Part 15.247, 15.407, RSS-210	Project Coordinator:	-
		Class:	N/A

Spurious Emissions excluding allocated band (final measurements at 3m)

Frequency MHz	Level dB μ V/m	Pol v/h	15.209 / 15.247		Detector PK/QP/Avg	Azimuth degrees	Height meters	Comments
			Limit	Margin				
4923.980	43.5	V	54.0	-10.5	AVG	207	1.0	RB 1 MHz;VB 10 Hz;Peak
4924.070	49.0	V	74.0	-25.0	PK	207	1.0	RB 1 MHz;VB 3 MHz;Peak
1174.670	30.3	H	54.0	-23.7	AVG	252	1.7	RB 1 MHz;VB 10 Hz;Peak
1195.670	48.7	H	74.0	-25.3	PK	252	1.7	RB 1 MHz;VB 3 MHz;Peak
1597.800	30.3	V	54.0	-23.7	AVG	284	1.8	RB 1 MHz;VB 10 Hz;Peak
1597.470	48.6	V	74.0	-25.4	PK	284	1.8	RB 1 MHz;VB 3 MHz;Peak

Preliminary Measurements (Peak versus average limit) at 20-30cm from EUT

Frequency MHz	Level dB μ V/m	Pol v/h	15.209/15.247		Detector PK/QP/Avg	Azimuth degrees	Height meters	Comments
			Limit	Margin				
2488.980	53.1	H	-	-	Peak	180	1.0	Refer to Band Edge test result
2623.250	41.0	H	54.0	-13.0	Peak	180	1.0	Note 2

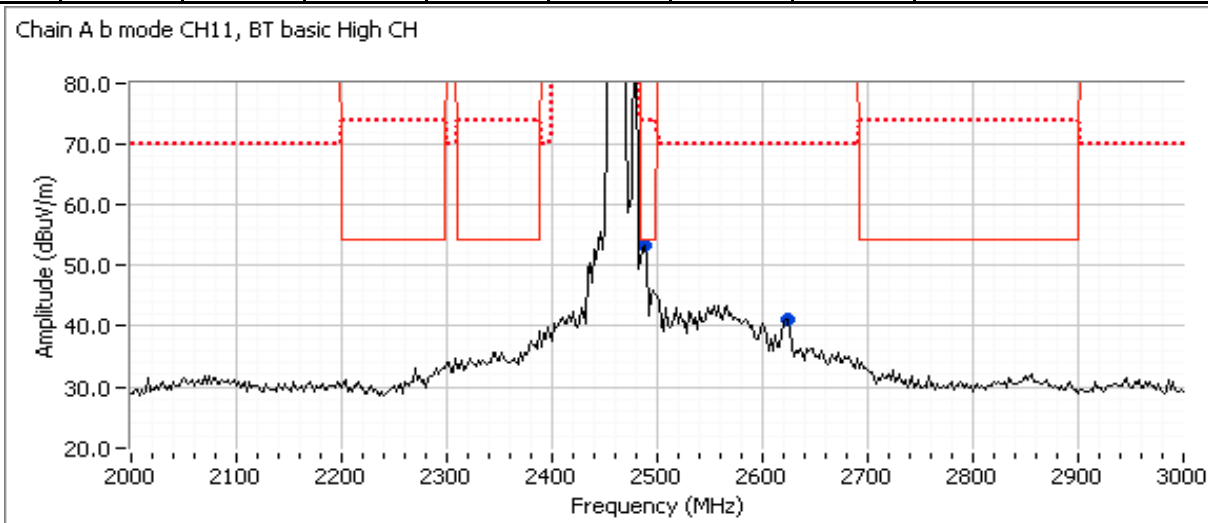

Spurious Emissions near allocated band (final measurements at 3m)

Frequency MHz	Level dB μ V/m	Pol v/h	15.209 / 15.247		Detector PK/QP/Avg	Azimuth degrees	Height meters	Comments
			Limit	Margin				
2623.250	41.0	H	54.0	-13.0	Peak	180	1.0	Note 2

No intermodulation founded

- Note 1: For emissions in restricted bands, the limit of 15.209 was used. For all other emissions, the limit was set 20dB below the level of the fundamental and measured in 100kHz.
- Note 2: Signal is not in a restricted band but the more stringent restricted band limit was used.
- Note 3: Signal is only present when Bluetooth is enabled, average correction for hopping occupancy could be applied.



EMC Test Data

Client: Intel Corporation	Job Number: J94914
Model: 7265D2W	T-Log Number: T95472
Contact: Steve Hackett	Project Manager: Christine Krebill
Standard: FCC Part 15.247, 15.407, RSS-210	Project Coordinator: -
	Class: N/A

Run #3: 1-10GHz, 802.11g @ 2412 MHz Chain A, BT Basic Rate @ 2402 MHz Chain B
 Date of Test: 6/18/2014 Test Location: FT Chamber #4
 Test Engineer: Jack Liu / R. Varelas Config Change: None

	Power Settings		
	Target (dBm)	Measured (dBm)	Software Setting
Chain A	14.0	17.7	20.5
Chain B	-	5.0	10.0

Note - measured power in table above is average power, for reference only.

Perform normal 1-10 GHz scan with filter for fundamental and then 2-3 GHz scan 20-30 cm from the product without filter.

Preliminary Measurements (Peak versus average limit)

Frequency	Level	Pol	15.209/15.247		Detector	Azimuth	Height	Comments
MHz	dB μ V/m	v/h	Limit	Margin	Pk/QP/Avg	degrees	meters	
1191.670	46.3	V	54.0	-7.7	Peak	232	1.0	
1241.670	40.0	H	70.0	-30.0	Peak	216	1.0	
1591.670	40.4	V	54.0	-13.6	Peak	108	2.0	

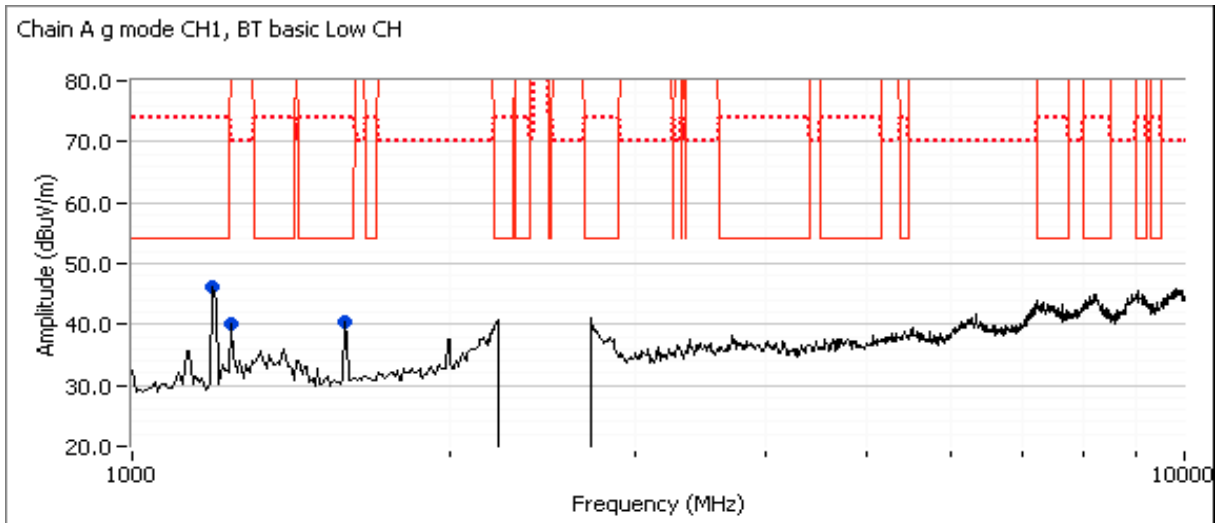



EMC Test Data

Client:	Intel Corporation	Job Number:	J94914
Model:	7265D2W	T-Log Number:	T95472
Contact:	Steve Hackett	Project Manager:	Christine Krebill
Standard:	FCC Part 15.247, 15.407, RSS-210	Project Coordinator:	-
		Class:	N/A

Spurious Emissions excluding allocated band (final measurements at 3m)

Frequency	Level	Pol	15.209 / 15.247		Detector	Azimuth	Height	Comments
MHz	dB μ V/m	v/h	Limit	Margin	PK/QP/Avg	degrees	meters	
1197.000	31.8	V	54.0	-22.2	AVG	227	1.0	RB 1 MHz;VB 10 Hz;Peak
1196.000	56.3	V	74.0	-17.7	PK	227	1.0	RB 1 MHz;VB 3 MHz;Peak
1260.940	29.1	H	54.0	-24.9	AVG	129	1.4	Note 2
1241.070	42.8	H	74.0	-31.2	PK	129	1.4	Note 2
1594.540	30.9	V	54.0	-23.1	AVG	80	1.5	RB 1 MHz;VB 10 Hz;Peak
1594.070	46.2	V	74.0	-27.8	PK	80	1.5	RB 1 MHz;VB 3 MHz;Peak

Preliminary Measurements (Peak versus average limit) at 20-30cm from EUT

Frequency	Level	Pol	15.209/15.247		Detector	Azimuth	Height	Comments
MHz	dB μ V/m	v/h	Limit	Margin	PK/QP/Avg	degrees	meters	
2462.930	55.3	V	-	-	Peak	180	1.0	In band intermittent signal
2384.770	54.8	V	-	-	Peak	180	1.0	Refer to Band Edge test result

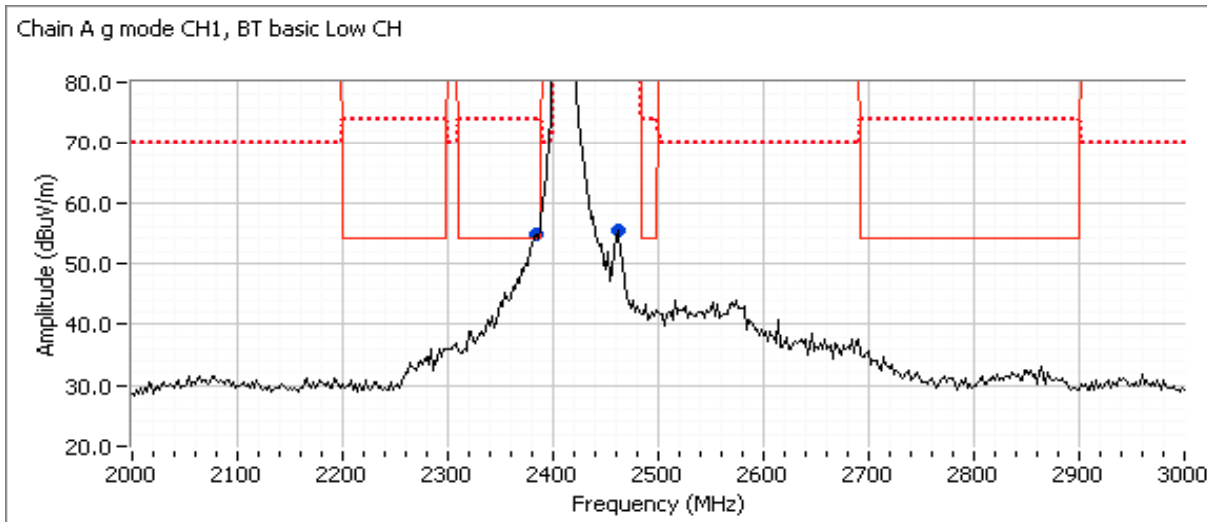

Spurious Emissions near allocated band (final measurements at 3m)

Frequency	Level	Pol	15.209 / 15.247		Detector	Azimuth	Height	Comments
MHz	dB μ V/m	v/h	Limit	Margin	PK/QP/Avg	degrees	meters	

No intermodulation founded

- Note 1: For emissions in restricted bands, the limit of 15.209 was used. For all other emissions, the limit was set 20dB below the level of the fundamental and measured in 100kHz.
- Note 2: Signal is not in a restricted band but the more stringent restricted band limit was used.
- Note 3: Signal is only present when Bluetooth is enabled, average correction for hopping occupancy could be applied



EMC Test Data

Client: Intel Corporation	Job Number: J94914
Model: 7265D2W	T-Log Number: T95472
Contact: Steve Hackett	Project Manager: Christine Krebill
Standard: FCC Part 15.247, 15.407, RSS-210	Project Coordinator: -
	Class: N/A

Run #4: 1-10GHz, 802.11g @ 2462 MHz Chain A, BT Basic Rate @ 2480 MHz Chain B
 Date of Test: 6/18/2014 Test Location: FT Chamber #4
 Test Engineer: Jack Liu / R. Varelas Config Change: None

	Target (dBm)	Power Settings Measured (dBm)	Software Setting
Chain A	12.5	17.5	19.5
Chain B	-	5.0	10.0

Note - measured power in table above is average power, for reference only.

Perform normal 1-10 GHz scan with filter for fundamental and then 2-3 GHz scan 20-30 cm from the product without filter.

Preliminary Measurements (Peak versus average limit)

Frequency	Level	Pol	15.209/15.247		Detector	Azimuth	Height	Comments
MHz	dB μ V/m	v/h	Limit	Margin	PK/QP/Avg	degrees	meters	
1600.000	40.2	V	54.0	-13.8	Peak	221	1.5	
1200.000	43.9	V	54.0	-10.1	Peak	259	1.0	

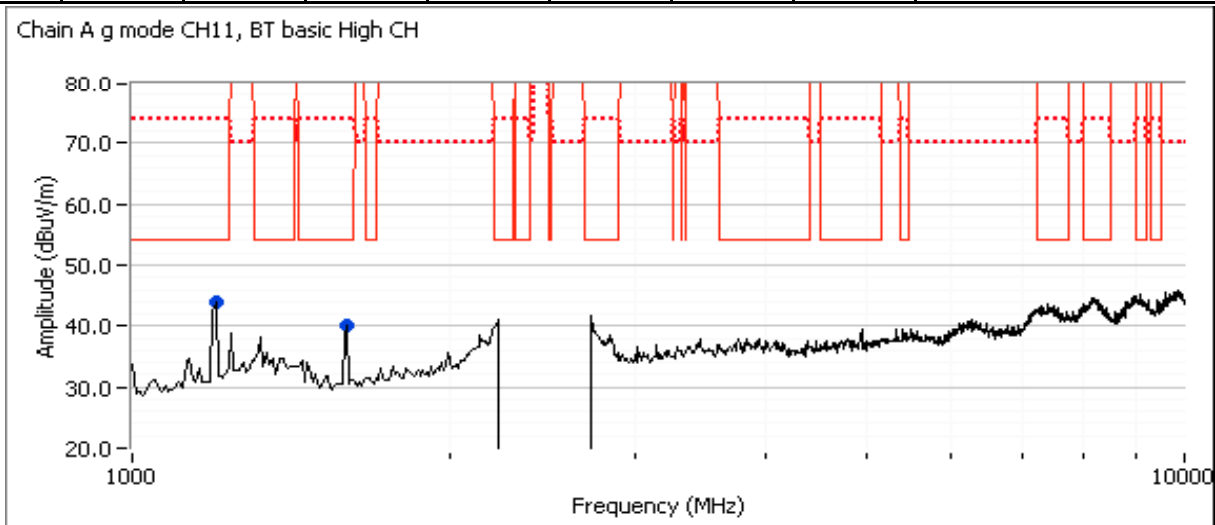

Spurious Emissions excluding allocated band (final measurements at 3m)

Frequency	Level	Pol	15.209 / 15.247		Detector	Azimuth	Height	Comments
MHz	dB μ V/m	v/h	Limit	Margin	PK/QP/Avg	degrees	meters	
1598.670	31.1	V	54.0	-22.9	AVG	62	1.5	RB 1 MHz;VB 10 Hz;Peak
1593.930	47.7	V	74.0	-26.3	PK	62	1.5	RB 1 MHz;VB 3 MHz;Peak
1202.800	32.9	V	54.0	-21.1	AVG	268	1.2	RB 1 MHz;VB 10 Hz;Peak
1198.730	53.3	V	74.0	-20.7	PK	268	1.2	RB 1 MHz;VB 3 MHz;Peak



EMC Test Data

Client: Intel Corporation	Job Number: J94914
Model: 7265D2W	T-Log Number: T95472
Contact: Steve Hackett	Project Manager: Christine Krebill
Standard: FCC Part 15.247, 15.407, RSS-210	Project Coordinator: -
	Class: N/A

Preliminary Measurements (Peak versus average limit) at 20-30cm from EUT

Frequency	Level	Pol	15.209/15.247		Detector	Azimuth	Height	Comments
MHz	dB μ V/m	v/h	Limit	Margin	PK/QP/Avg	degrees	meters	
2490.980	55.6	V	-	-	Peak	180	1.0	Refer to Band Edge test result

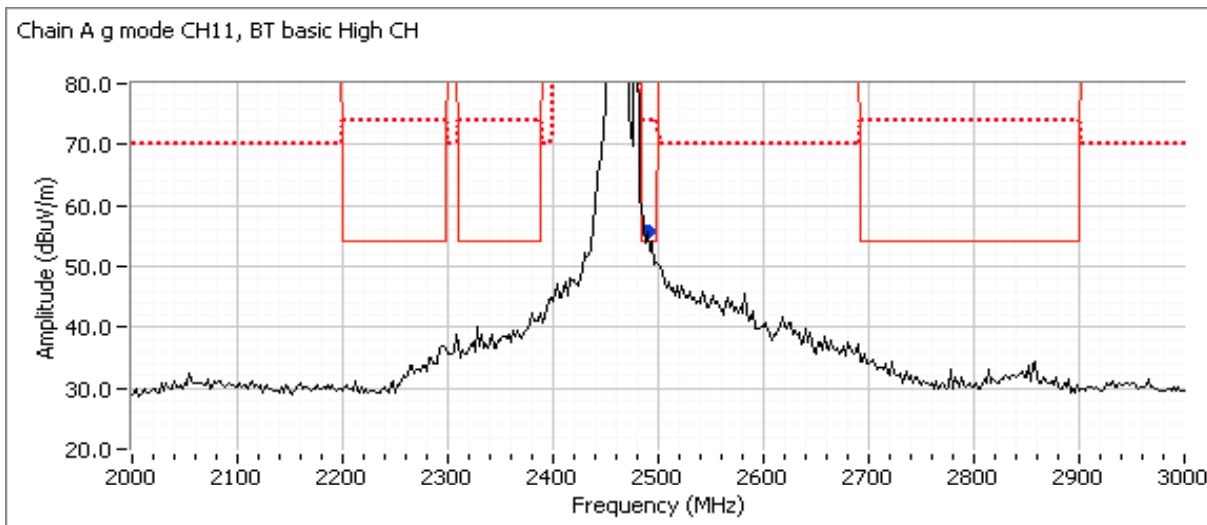

Spurious Emissions near allocated band (final measurements at 3m)

Frequency	Level	Pol	15.209 / 15.247		Detector	Azimuth	Height	Comments
MHz	dB μ V/m	v/h	Limit	Margin	PK/QP/Avg	degrees	meters	

No intermodulation founded

- Note 1: For emissions in restricted bands, the limit of 15.209 was used. For all other emissions, the limit was set 20dB below the level of the fundamental and measured in 100kHz.
- Note 2: Signal is not in a restricted band but the more stringent restricted band limit was used.
- Note 3: Signal is only present when Bluetooth is enabled, average correction for hopping occupancy could be applied



EMC Test Data

Client:	Intel Corporation	Job Number:	J94914
Model:	7265D2W	T-Log Number:	T95472
Contact:	Steve Hackett	Project Manager:	Christine Krebill
Standard:	FCC Part 15.247, 15.407, RSS-210	Project Coordinator:	-
		Class:	N/A

Run #5: 1-10GHz, 802.11b @ 2437 MHz Chain A, BT Basic Rate @ 2402 MHz Chain B

Date of Test: 6/19/2014 Test Location: FT Chamber 4
 Test Engineer: Jack Liu / R. Varelas Config Change: None

	Target (dBm)	Power Settings Measured (dBm)	Software Setting
Chain A	17.5	17.7	14.0
Chain B	-	4.8	10.0

Note - measured power in table above is average power, for reference only.

Perform normal 1-10 GHz scan with filter for fundamental and then 2-3 GHz scan 20-30 cm from the product without filter.

Preliminary Measurements (Peak versus average limit)

Frequency	Level	Pol	15.209/15.247		Detector	Azimuth	Height	Comments
MHz	dB μ V/m	v/h	Limit	Margin	PK/QP/Avg	degrees	meters	
1195.120	44.6	H	54.0	-9.4	Peak	114	1.3	
1594.440	41.2	V	54.0	-12.8	Peak	227	1.6	
4874.170	42.4	V	54.0	-11.6	Peak	141	1.3	

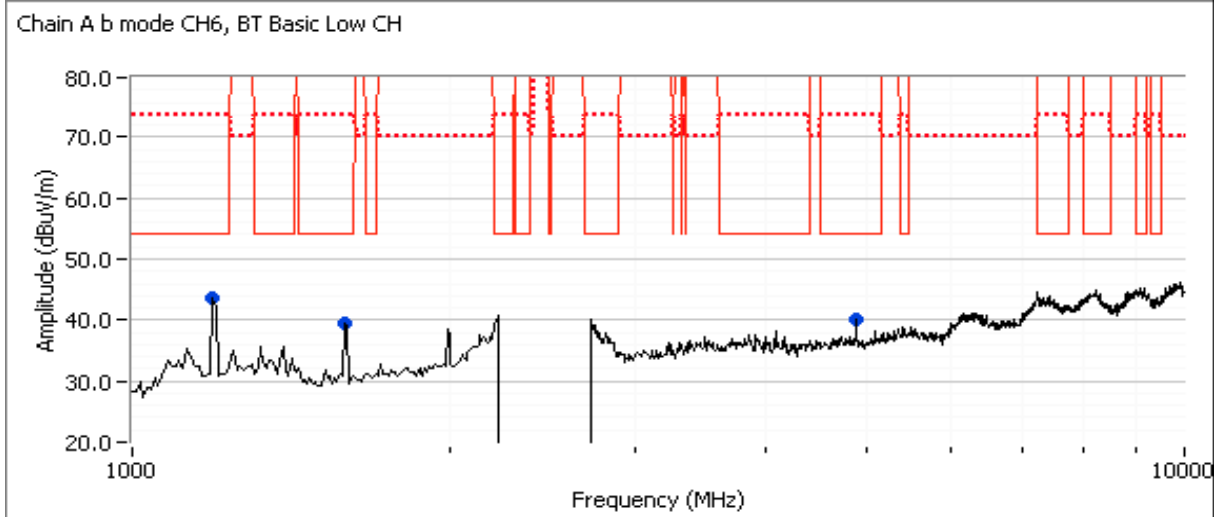

Spurious Emissions excluding allocated band (final measurements at 3m)

Frequency	Level	Pol	15.209 / 15.247		Detector	Azimuth	Height	Comments
MHz	dB μ V/m	v/h	Limit	Margin	PK/QP/Avg	degrees	meters	
4873.970	40.2	V	54.0	-13.8	AVG	154	1.9	RB 1 MHz;VB 10 Hz;Peak
4873.870	46.9	V	74.0	-27.1	PK	154	1.9	RB 1 MHz;VB 3 MHz;Peak
1594.510	30.4	V	54.0	-23.6	AVG	223	1.3	RB 1 MHz;VB 10 Hz;Peak
1596.370	46.1	V	74.0	-27.9	PK	223	1.3	RB 1 MHz;VB 3 MHz;Peak
1196.570	30.7	H	54.0	-23.3	AVG	116	1.6	RB 1 MHz;VB 10 Hz;Peak
1194.630	53.7	H	74.0	-20.3	PK	116	1.6	RB 1 MHz;VB 3 MHz;Peak



EMC Test Data

Client:	Intel Corporation	Job Number:	J94914
Model:	7265D2W	T-Log Number:	T95472
Contact:	Steve Hackett	Project Manager:	Christine Krebill
Standard:	FCC Part 15.247, 15.407, RSS-210	Project Coordinator:	-
		Class:	N/A

Preliminary Measurements (Peak versus average limit) at 100cm from EUT

Frequency	Level	Pol	15.209/15.247		Detector	Azimuth	Height	Comments
MHz	dB μ V/m	v/h	Limit	Margin	PK/QP/Avg	degrees	meters	
2368.740	49.2	H	54.0	-4.8	Peak	210	1.5	

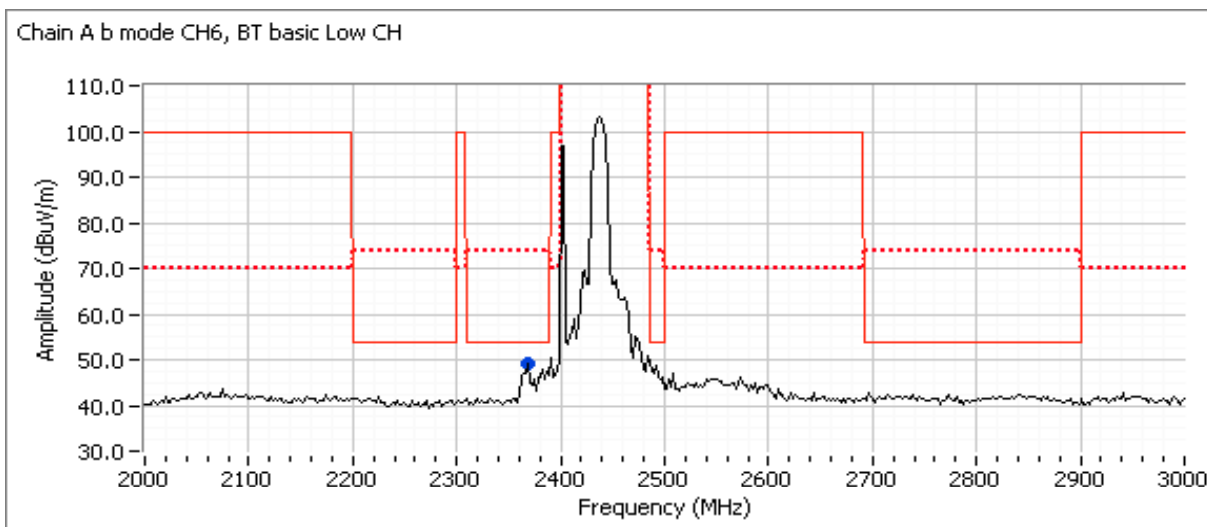

Spurious Emissions near allocated band (final measurements at 3m)

Frequency	Level	Pol	15.209 / 15.247		Detector	Azimuth	Height	Comments
MHz	dB μ V/m	v/h	Limit	Margin	PK/QP/Avg	degrees	meters	
2366.050	46.1	H	54.0	-7.9	AVG	155	1.4	POS; RB 1 MHz; VB: 10 Hz
2366.300	54.2	H	74.0	-19.8	PK	155	1.4	POS; RB 1 MHz; VB: 3 MHz

- Note 1: For emissions in restricted bands, the limit of 15.209 was used. For all other emissions, the limit was set 20dB below the level of the fundamental and measured in 100kHz.
- Note 1: For emissions in restricted bands, the limit of 15.209 was used. For all other emissions, the limit was set 30dB below the level of the fundamental and measured in 100kHz.
- Note 2: Signal is not in a restricted band but the more stringent restricted band limit was used.
- Note 3: Signal is only present when Bluetooth is enabled, average correction for hopping occupancy could be applied



EMC Test Data

Client: Intel Corporation	Job Number: J94914
Model: 7265D2W	T-Log Number: T95472
Contact: Steve Hackett	Project Manager: Christine Krebill
Standard: FCC Part 15.247, 15.407, RSS-210	Project Coordinator: -
	Class: N/A

Run #6: 1-10GHz, 802.11b @ 2412 MHz Chain A, BT Basic Rate @ 2440 MHz Chain B
 Date of Test: 6/19/2014 Test Location: FT Chamber 4
 Test Engineer: Jack Liu Config Change: None

	Target (dBm)	Power Settings Measured (dBm)	Software Setting
Chain A	16.5	17.6	14.5
Chain B	-	5.1	10.0

Note - measured power in table above is average power, for reference only.

Perform normal 1-10 GHz scan with filter for fundamental and then 2-3 GHz scan 20-30 cm from the product without filter.

Preliminary Measurements (Peak versus average limit)

Frequency	Level	Pol	15.209/15.247		Detector	Azimuth	Height	Comments
MHz	dB μ V/m	v/h	Limit	Margin	PK/QP/Avg	degrees	meters	
1198.140	44.7	V	54.0	-9.3	Peak	275	1.3	
1590.120	40.7	V	54.0	-13.3	Peak	87	1.9	

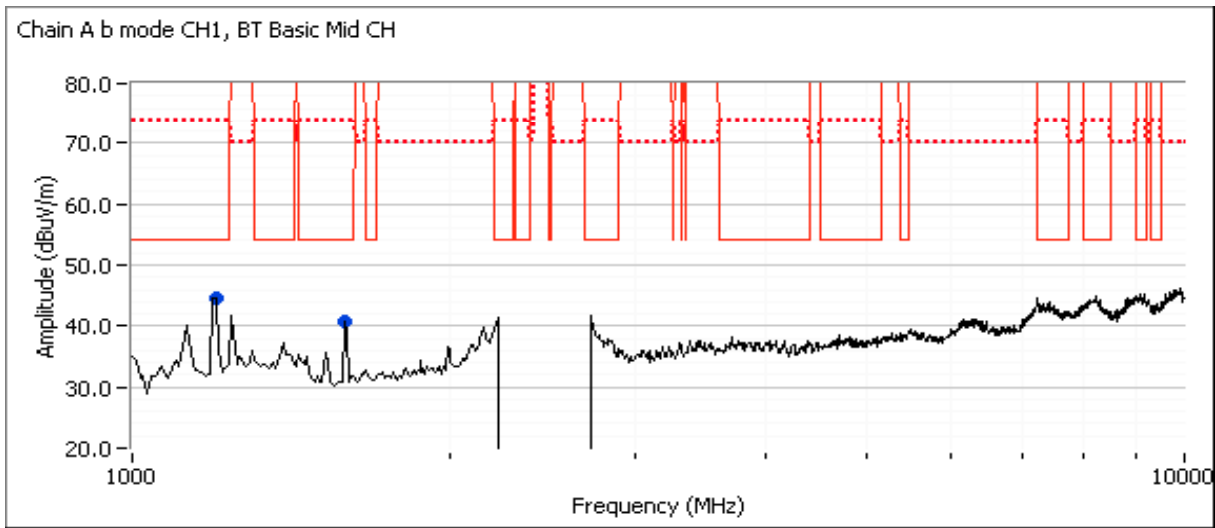

Spurious Emissions excluding allocated band (final measurements at 3m)

Frequency	Level	Pol	15.209 / 15.247		Detector	Azimuth	Height	Comments
MHz	dB μ V/m	v/h	Limit	Margin	PK/QP/Avg	degrees	meters	
1198.160	31.0	V	54.0	-23.0	AVG	277	1.0	RB 1 MHz;VB 10 Hz;Peak
1199.340	50.0	V	74.0	-24.0	PK	277	1.0	RB 1 MHz;VB 3 MHz;Peak
1591.090	28.8	V	54.0	-25.2	AVG	93	1.0	RB 1 MHz;VB 10 Hz;Peak
1590.570	41.2	V	74.0	-32.8	PK	93	1.0	RB 1 MHz;VB 3 MHz;Peak



EMC Test Data

Client:	Intel Corporation	Job Number:	J94914
Model:	7265D2W	T-Log Number:	T95472
Contact:	Steve Hackett	Project Manager:	Christine Krebill
Standard:	FCC Part 15.247, 15.407, RSS-210	Project Coordinator:	-
		Class:	N/A

Preliminary Measurements (Peak versus average limit) at 100cm from EUT

Frequency	Level	Pol	15.209/15.247		Detector	Azimuth	Height	Comments
MHz	dB μ V/m	v/h	Limit	Margin	PK/QP/Avg	degrees	meters	
2386.770	52.5	H	-	-	Peak	203	1.0	Refer to Band Edge test result
2352.710	44.9	H	54.0	-9.1	Peak	204	1.5	

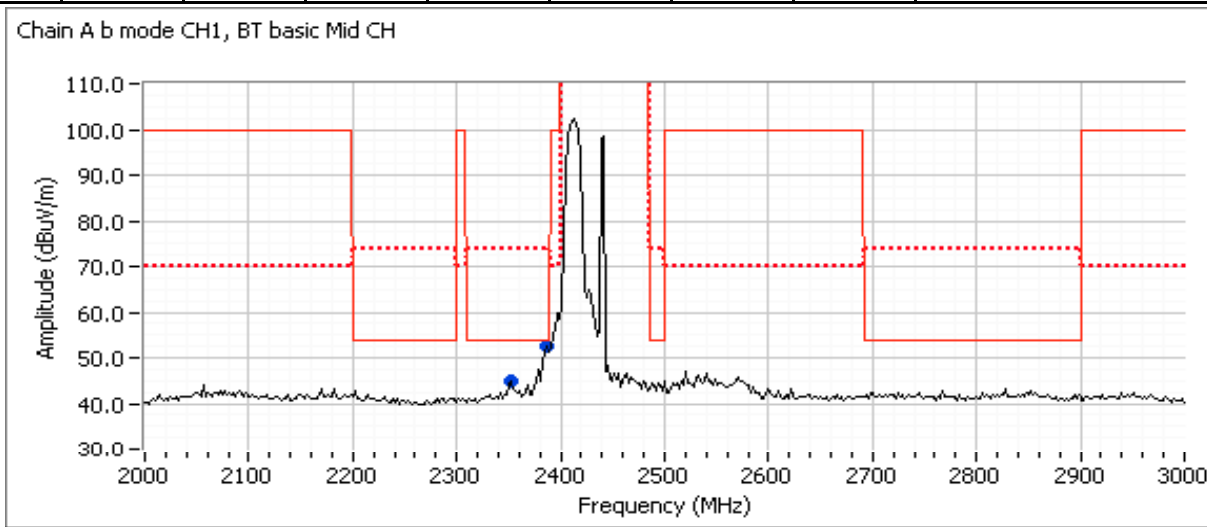

Spurious Emissions near allocated band (final measurements at 3m)

Frequency	Level	Pol	15.209 / 15.247		Detector	Azimuth	Height	Comments
MHz	dB μ V/m	v/h	Limit	Margin	PK/QP/Avg	degrees	meters	
2356.760	41.9	H	54.0	-12.1	AVG	204	1.6	POS; RB 1 MHz; VB: 10 Hz
2356.600	51.1	H	74.0	-22.9	PK	204	1.6	POS; RB 1 MHz; VB: 3 MHz

- Note 1: For emissions in restricted bands, the limit of 15.209 was used. For all other emissions, the limit was set 20dB below the level of the fundamental and measured in 100kHz.
- Note 1: For emissions in restricted bands, the limit of 15.209 was used. For all other emissions, the limit was set 30dB below the level of the fundamental and measured in 100kHz.
- Note 2: Signal is not in a restricted band but the more stringent restricted band limit was used.
- Note 3: Signal is only present when Bluetooth is enabled, average correction for hopping occupancy could be applied



EMC Test Data

Client: Intel Corporation	Job Number: J94914
Model: 7265D2W	T-Log Number: T95472
Contact: Steve Hackett	Project Manager: Christine Krebill
Standard: FCC Part 15.247, 15.407, RSS-210	Project Coordinator: -
	Class: N/A

Run #7: 1-10GHz, 802.11b @ 2462 MHz Chain A, BT Basic Rate @ 2440 MHz Chain B
 Date of Test: 6/19/2014 Test Location: FT Chamber 4
 Test Engineer: Jack Liu Config Change: None

	Target (dBm)	Power Settings Measured (dBm)	Software Setting
Chain A	16.5	17.6	14.5
Chain B	-	5.1	10.0

Note - measured power in table above is average power, for reference only.

Perform normal 1-10 GHz scan with filter for fundamental and then 2-3 GHz scan 20-30 cm from the product without filter.

Preliminary Measurements (Peak versus average limit)

Frequency	Level	Pol	15.209/15.247		Detector	Azimuth	Height	Comments
MHz	dB μ V/m	v/h	Limit	Margin	PK/QP/Avg	degrees	meters	
1195.250	45.3	H	54.0	-8.7	Peak	111	1.3	
1590.780	39.5	H	54.0	-14.5	Peak	103	1.0	
4924.000	43.7	H	54.0	-10.3	Peak	189	1.6	

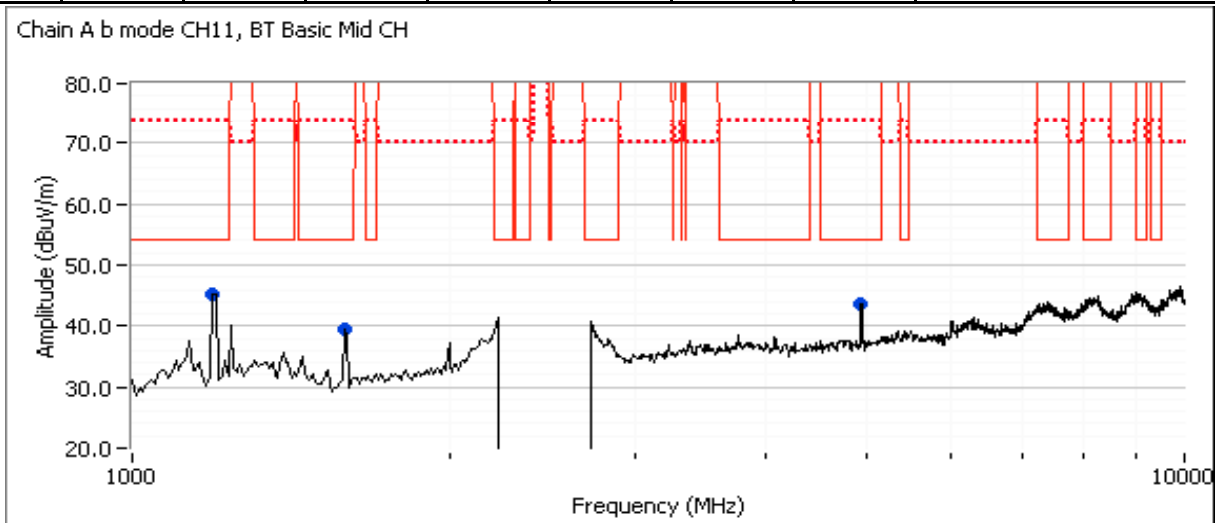

Spurious Emissions excluding allocated mid band (final measurements at 3m)

Frequency	Level	Pol	15.209 / 15.247		Detector	Azimuth	Height	Comments
MHz	dB μ V/m	v/h	Limit	Margin	PK/QP/Avg	degrees	meters	
4923.960	41.3	H	54.0	-12.7	AVG	147	1.0	RB 1 MHz;VB 10 Hz;Peak
4924.020	46.9	H	74.0	-27.1	PK	147	1.0	RB 1 MHz;VB 3 MHz;Peak
1196.560	29.9	H	54.0	-24.1	AVG	116	1.6	RB 1 MHz;VB 10 Hz;Peak
1196.320	53.6	H	74.0	-20.4	PK	116	1.6	RB 1 MHz;VB 3 MHz;Peak
1592.010	29.2	H	54.0	-24.8	AVG	101	1.0	RB 1 MHz;VB 10 Hz;Peak
1592.100	40.7	H	74.0	-33.3	PK	101	1.0	RB 1 MHz;VB 3 MHz;Peak



EMC Test Data

Client: Intel Corporation	Job Number: J94914
Model: 7265D2W	T-Log Number: T95472
Contact: Steve Hackett	Project Manager: Christine Krebill
Standard: FCC Part 15.247, 15.407, RSS-210	Project Coordinator: -
	Class: N/A

Preliminary Measurements (Peak versus average limit) at 20-30cm from EUT

Frequency	Level	Pol	15.209/15.247		Detector	Azimuth	Height	Comments
MHz	dB μ V/m	v/h	Limit	Margin	PK/QP/Avg	degrees	meters	
2488.980	54.7	H	-	-	Peak	182	1.0	Refer to Band Edge test result

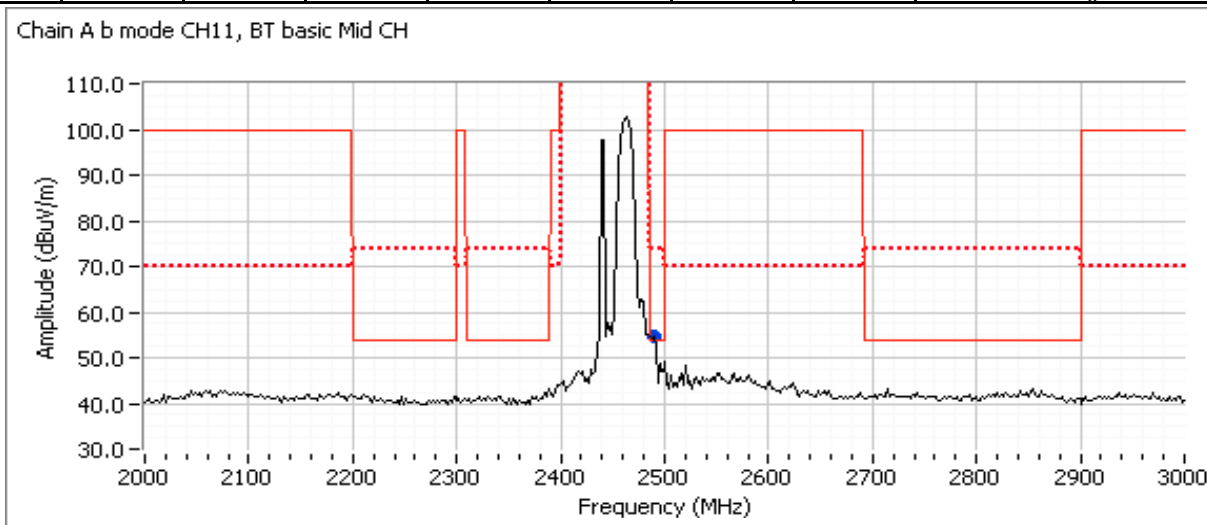

Spurious Emissions near allocated band (final measurements at 3m)

Frequency	Level	Pol	15.209 / 15.247		Detector	Azimuth	Height	Comments
MHz	dB μ V/m	v/h	Limit	Margin	PK/QP/Avg	degrees	meters	

No intermodulation founded

Note 1: For emissions in restricted bands, the limit of 15.209 was used. For all other emissions, the limit was set 20dB below the level of the fundamental and measured in 100kHz.

Note 1: For emissions in restricted bands, the limit of 15.209 was used. For all other emissions, the limit was set 30dB below the level of the fundamental and measured in 100kHz.

Note 2: Signal is not in a restricted band but the more stringent restricted band limit was used.

Note 3: Signal is only present when Bluetooth is enabled, average correction for hopping occupancy could be applied



EMC Test Data

Client: Intel Corporation	Job Number: J94914
Model: 7265D2W	T-Log Number: T95472
Contact: Steve Hackett	Project Manager: Christine Krebill
Standard: FCC Part 15.247, 15.407, RSS-210	Project Coordinator: -
	Class: N/A

Run #8: 1-10GHz, 802.11b @ 2437 MHz Chain A, BT Basic Rate @ 2480 MHz Chain B
 Date of Test: 6/19/2014 Test Location: FT Chamber 4
 Test Engineer: Jack Liu Config Change: None

	Target (dBm)	Power Settings Measured (dBm)	Software Setting
Chain A	16.5	17.7	14.0
Chain B	-	5.0	10.0

Note - measured power in table above is average power, for reference only.

Perform normal 1-10 GHz scan with filter for fundamental and then 2-3 GHz scan 20-30 cm from the product without filter.

Preliminary Measurements (Peak versus average limit)

Frequency	Level	Pol	15.209/15.247		Detector	Azimuth	Height	Comments
MHz	dB μ V/m	v/h	Limit	Margin	PK/QP/Avg	degrees	meters	
1192.970	44.7	V	54.0	-9.3	Peak	224	1.0	
1594.110	41.0	H	54.0	-13.0	Peak	120	1.0	
4874.080	42.6	V	54.0	-11.4	Peak	154	1.9	

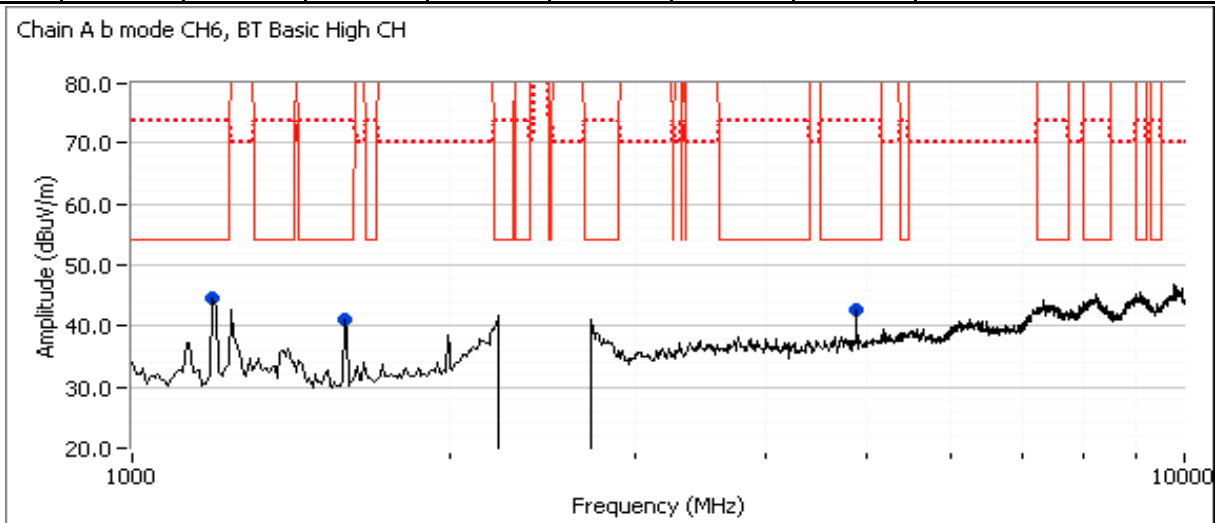

Spurious Emissions excluding allocated band (final measurements at 3m)

Frequency	Level	Pol	15.209 / 15.247		Detector	Azimuth	Height	Comments
MHz	dB μ V/m	v/h	Limit	Margin	PK/QP/Avg	degrees	meters	
4874.020	41.1	V	54.0	-12.9	AVG	154	1.9	RB 1 MHz;VB 10 Hz;Peak
4874.190	47.0	V	74.0	-27.0	PK	154	1.9	RB 1 MHz;VB 3 MHz;Peak
1595.050	31.7	H	54.0	-22.3	AVG	121	1.0	RB 1 MHz;VB 10 Hz;Peak
1593.860	49.9	H	74.0	-24.1	PK	121	1.0	RB 1 MHz;VB 3 MHz;Peak
1194.440	32.5	V	54.0	-21.5	AVG	225	1.0	RB 1 MHz;VB 10 Hz;Peak
1194.200	54.0	V	74.0	-20.0	PK	225	1.0	RB 1 MHz;VB 3 MHz;Peak



EMC Test Data

Client: Intel Corporation	Job Number: J94914
Model: 7265D2W	T-Log Number: T95472
Contact: Steve Hackett	Project Manager: Christine Krebill
Standard: FCC Part 15.247, 15.407, RSS-210	Project Coordinator: -
	Class: N/A

Preliminary Measurements (Peak versus average limit) at 20-30cm from EUT

Frequency	Level	Pol	15.209/15.247		Detector	Azimuth	Height	Comments
MHz	dB μ V/m	v/h	Limit	Margin	PK/QP/Avg	degrees	meters	
No emission founded								

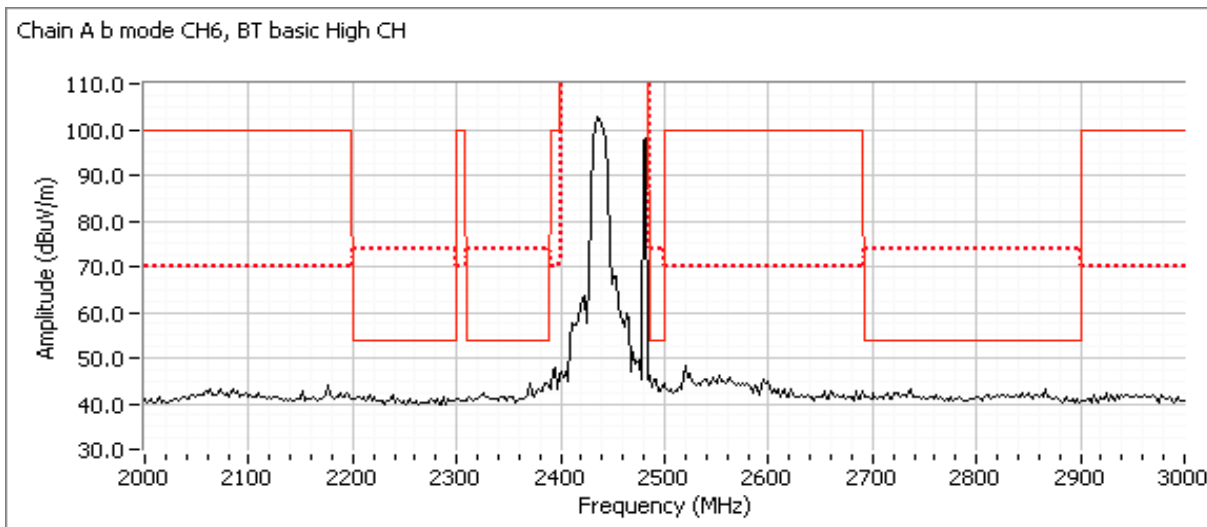

Spurious Emissions near allocated band (final measurements at 3m)

Frequency	Level	Pol	15.209 / 15.247		Detector	Azimuth	Height	Comments
MHz	dB μ V/m	v/h	Limit	Margin	PK/QP/Avg	degrees	meters	
No intermodulation founded								

- Note 1: For emissions in restricted bands, the limit of 15.209 was used. For all other emissions, the limit was set 20dB below the level of the fundamental and measured in 100kHz.
- Note 1: For emissions in restricted bands, the limit of 15.209 was used. For all other emissions, the limit was set 30dB below the level of the fundamental and measured in 100kHz.
- Note 2: Signal is not in a restricted band but the more stringent restricted band limit was used.
- Note 3: Signal is only present when Bluetooth is enabled, average correction for hopping occupancy could be applied



EMC Test Data

Client: Intel Corporation	Job Number: J94914
Model: 7265D2W	T-Log Number: T95472
Contact: Steve Hackett	Project Manager: Christine Krebill
Standard: FCC Part 15.247, 15.407, RSS-210	Project Coordinator: -
	Class: N/A

Run #9: 1-10GHz, 802.11b @ 2412 MHz Chain A, BT EDR Rate @ 2440 MHz Chain B
 Date of Test: 6/19/2014 Test Location: FT Chamber 4
 Test Engineer: Jack Liu Config Change: None

	Target (dBm)	Power Settings Measured (dBm)	Software Setting
Chain A	16.5	17.7	14.0
Chain B	-	1.2	6.0

Note - measured power in table above is average power, for reference only.

Perform normal 1-10 GHz scan with filter for fundamental and then 2-3 GHz scan 100 cm from the product without filter.

Preliminary Measurements (Peak versus average limit)

Frequency	Level	Pol	15.209/15.247		Detector	Azimuth	Height	Comments
MHz	dB μ V/m	v/h	Limit	Margin	PK/QP/Avg	degrees	meters	
1245.000	46.2	H	70.0	-23.8	Peak	119	1.3	
1593.170	38.0	H	54.0	-16.0	Peak	124	1.0	
4924.030	45.2	V	54.0	-8.8	Peak	115	1.3	

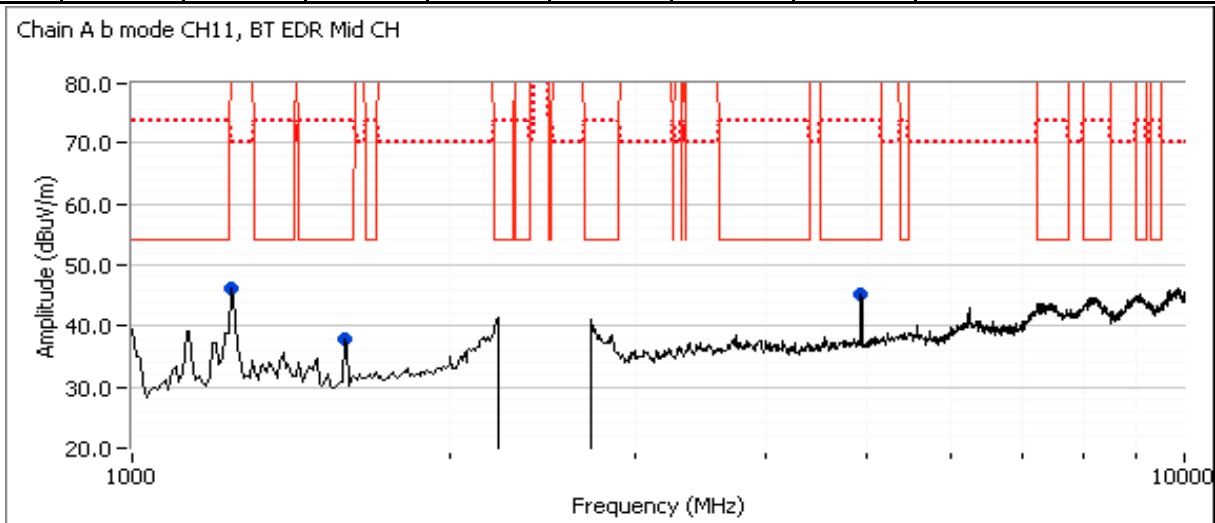

Spurious Emissions excluding allocated band (final measurements at 3m)

Frequency	Level	Pol	15.209 / 15.247		Detector	Azimuth	Height	Comments
MHz	dB μ V/m	v/h	Limit	Margin	PK/QP/Avg	degrees	meters	
4923.970	41.4	V	54.0	-12.6	AVG	146	1.9	RB 1 MHz;VB 10 Hz;Peak
4923.840	47.1	V	74.0	-26.9	PK	146	1.9	RB 1 MHz;VB 3 MHz;Peak
1593.770	32.0	H	54.0	-22.0	AVG	122	1.0	RB 1 MHz;VB 10 Hz;Peak
1592.460	47.7	H	74.0	-26.3	PK	122	1.0	RB 1 MHz;VB 3 MHz;Peak
1244.940	52.4	H	68.3	-15.9	PK	117	0.9	RB 1 MHz;VB 3 MHz;Peak



EMC Test Data

Client:	Intel Corporation	Job Number:	J94914
Model:	7265D2W	T-Log Number:	T95472
Contact:	Steve Hackett	Project Manager:	Christine Krebill
Standard:	FCC Part 15.247, 15.407, RSS-210	Project Coordinator:	-
		Class:	N/A

Preliminary Measurements (Peak versus average limit) at 20-30cm from EUT

Frequency	Level	Pol	15.209/15.247		Detector	Azimuth	Height	Comments
MHz	dB μ V/m	v/h	Limit	Margin	PK/QP/Avg	degrees	meters	

No intermodulation founded

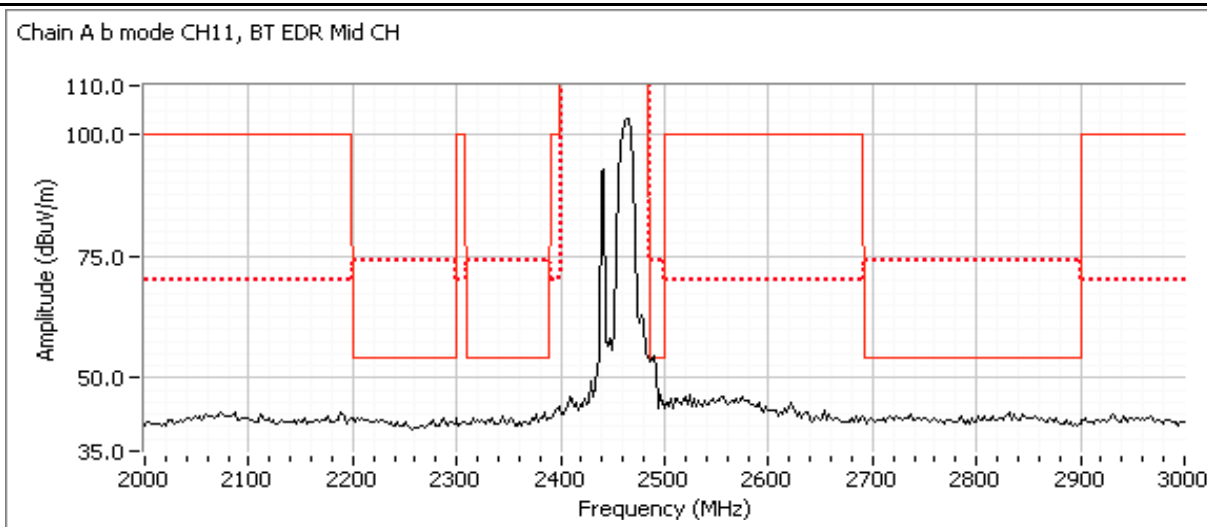

Spurious Emissions near allocated band (final measurements at 3m)

Frequency	Level	Pol	15.209 / 15.247		Detector	Azimuth	Height	Comments
MHz	dB μ V/m	v/h	Limit	Margin	PK/QP/Avg	degrees	meters	

No intermodulation founded

- Note 1: For emissions in restricted bands, the limit of 15.209 was used. For all other emissions, the limit was set 20dB below the level of the fundamental and measured in 100kHz.
- Note 1: For emissions in restricted bands, the limit of 15.209 was used. For all other emissions, the limit was set 30dB below the level of the fundamental and measured in 100kHz.
- Note 2: Signal is not in a restricted band but the more stringent restricted band limit was used.
- Note 3: Signal is only present when Bluetooth is enabled, average correction for hopping occupancy could be applied



EMC Test Data

Client: Intel Corporation	Job Number: J94914
Model: 7265D2W	T-Log Number: T95472
Contact: Steve Hackett	Project Manager: Christine Krebill
Standard: FCC Part 15.247, 15.407, RSS-210	Project Coordinator: -
	Class: N/A

Run #10: 1-10GHz, 802.11b @ 2412 MHz Chain A, BTLE @ 2440 MHz Chain B
 Date of Test: 6/19/2014 Test Location: FT Chamber 4
 Test Engineer: Jack Liu Config Change: None

	Target (dBm)	Power Settings Measured (dBm)	Software Setting
Chain A	16.5	17.7	14.0
Chain B	-	3.2	Default

Note - measured power in table above is average power, for reference only.

Perform normal 1-10 GHz scan with filter for fundamental and then 2-3 GHz scan 100 cm from the product without filter.

Preliminary Measurements (Peak versus average limit)

Frequency	Level	Pol	15.209/15.247		Detector	Azimuth	Height	Comments
MHz	dB μ V/m	v/h	Limit	Margin	PK/QP/Avg	degrees	meters	
1242.560	45.5	H	70.0	-24.5	Peak	308	1.6	
1598.530	38.2	V	54.0	-15.8	Peak	60	1.6	
4924.030	46.4	V	54.0	-7.6	Peak	125	2.2	

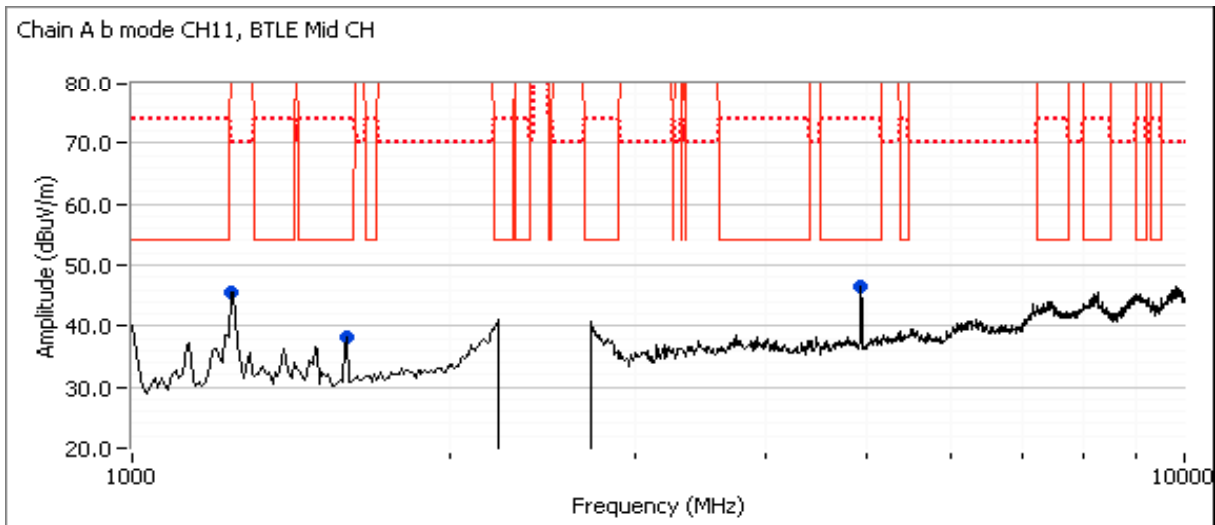

Spurious Emissions excluding allocated band (final measurements at 3m)

Frequency	Level	Pol	15.209 / 15.247		Detector	Azimuth	Height	Comments
MHz	dB μ V/m	v/h	Limit	Margin	PK/QP/Avg	degrees	meters	
4923.990	43.5	V	54.0	-10.5	AVG	157	1.9	RB 1 MHz;VB 10 Hz;Peak
4923.950	48.4	V	74.0	-25.6	PK	157	1.9	RB 1 MHz;VB 3 MHz;Peak
1243.960	48.4	H	68.3	-19.9	PK	306	1.6	RB 1 MHz;VB 3 MHz;Peak
1598.280	31.6	V	54.0	-22.4	AVG	58	1.5	RB 1 MHz;VB 10 Hz;Peak
1598.740	44.6	V	74.0	-29.4	PK	58	1.5	RB 1 MHz;VB 3 MHz;Peak



EMC Test Data

Client:	Intel Corporation	Job Number:	J94914
Model:	7265D2W	T-Log Number:	T95472
Contact:	Steve Hackett	Project Manager:	Christine Krebill
Standard:	FCC Part 15.247, 15.407, RSS-210	Project Coordinator:	-
		Class:	N/A

Preliminary Measurements (Peak versus average limit) at 20-30cm from EUT

Frequency	Level	Pol	15.209/15.247		Detector	Azimuth	Height	Comments
MHz	dB μ V/m	v/h	Limit	Margin	PK/QP/Avg	degrees	meters	

No intermodulation founded

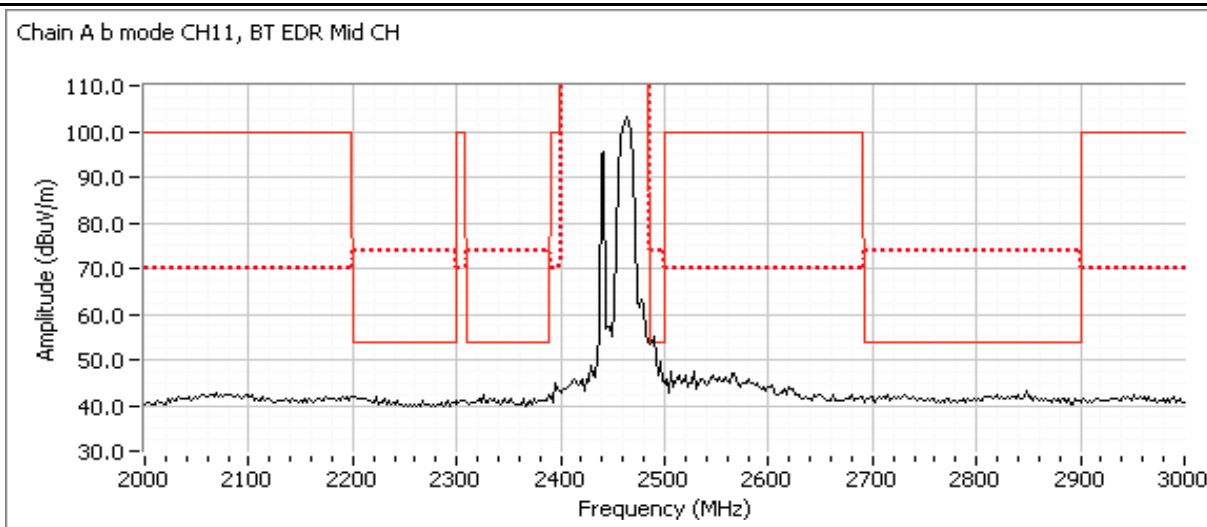

Spurious Emissions near allocated band (final measurments at 3m)

Frequency	Level	Pol	15.209 / 15.247		Detector	Azimuth	Height	Comments
MHz	dB μ V/m	v/h	Limit	Margin	PK/QP/Avg	degrees	meters	

No intermodulation founded

- Note 1: For emissions in restricted bands, the limit of 15.209 was used. For all other emissions, the limit was set 20dB below the level of the fundamental and measured in 100kHz.
- Note 1: For emissions in restricted bands, the limit of 15.209 was used. For all other emissions, the limit was set 30dB below the level of the fundamental and measured in 100kHz.
- Note 2: Signal is not in a restricted band but the more stringent restricted band limit was used.
- Note 3: Signal is only present when Bluetooth is enabled, average correction for hopping occupancy could be applied



EMC Test Data

Client:	Intel Corporation	Job Number:	J94914
Model:	7265D2W	T-Log Number:	T95472
Contact:	Steve Hackett	Project Manager:	Christine Krebill
Standard:	FCC Part 15.247, 15.407, RSS-210	Project Coordinator:	-
		Class:	N/A

Run #11: 1-15GHz, 802.11n20 @ 5200 MHz Chain A+B, BT Basic Rate @ 2440 MHz Chain B
 Date of Test: 6/18/2014 Test Location: FT Chamber #4
 Test Engineer: Jack Liu / R. Varelas Config Change: None

	Target (dBm)	Power Settings Measured (dBm)	Software Setting
WiFi A	16.0	16.6	31.0
WiFi B	16.0	16.5	32.0
Bluetooth	-	5.1	10.0

Note - measured power in table above is average power, for reference only.

Perform normal 7-15 GHz scan with filter for fundamental and then 1-4 and 4-7 GHz scans 20-30 cm from the product without filter.

Preliminary Measurements (Peak versus average limit)

Frequency	Level	Pol	15.209/15.247		Detector	Azimuth	Height	Comments
MHz	dB μ V/m	v/h	Limit	Margin	PK/QP/Avg	degrees	meters	
10401.330	39.0	H	68.3	-29.3	Peak	126	1.0	Harmonic of the EUT

Spurious Emissions (final measurements at 3m)

Frequency	Level	Pol	15.209 / 15.247		Detector	Azimuth	Height	Comments
MHz	dB μ V/m	v/h	Limit	Margin	PK/QP/Avg	degrees	meters	
refer to the spurious RE results								

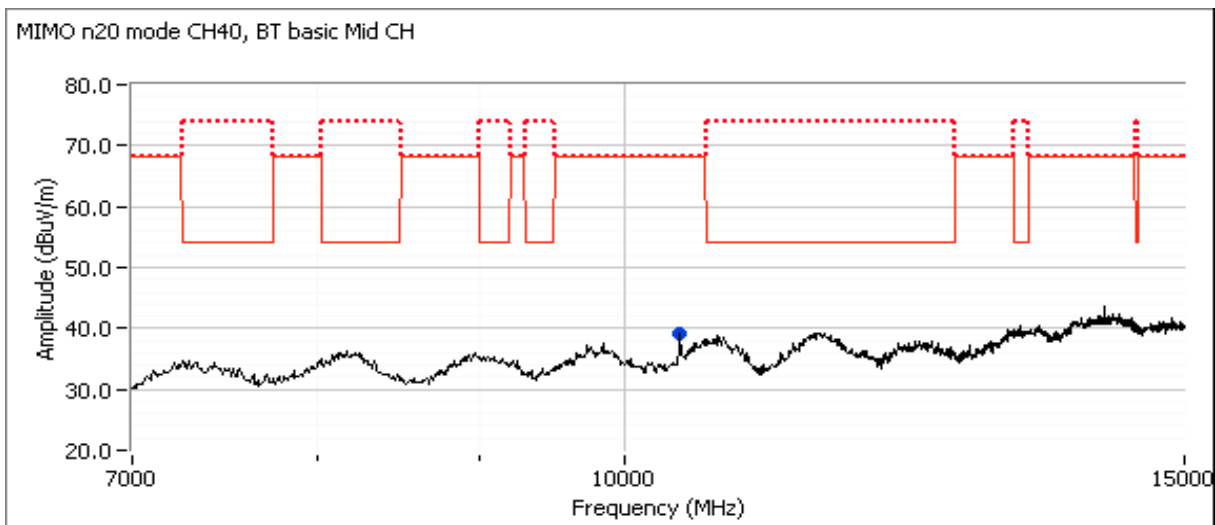



EMC Test Data

Client:	Intel Corporation	Job Number:	J94914
Model:	7265D2W	T-Log Number:	T95472
Contact:	Steve Hackett	Project Manager:	Christine Krebill
Standard:	FCC Part 15.247, 15.407, RSS-210	Project Coordinator:	-
		Class:	N/A

Preliminary Measurements (Peak versus average limit) at 20-30cm from EUT

Frequency	Level	Pol	15.209/15.247		Detector	Azimuth	Height	Comments
MHz	dB μ V/m	v/h	Limit	Margin	Pk/QP/Avg	degrees	meters	
5370.000	45.6	V	54.0	-8.4	Peak	180	1.0	
4980.000	40.9	V	54.0	-13.1	Peak	180	1.0	
2460.000	59.6	V	120.0	-60.4	Peak	180	1.0	emission is in band

Spurious Emissions (final measurments at 3m)

Frequency	Level	Pol	15.209 / 15.247		Detector	Azimuth	Height	Comments
MHz	dB μ V/m	v/h	Limit	Margin	Pk/QP/Avg	degrees	meters	
no emisissions found above the noise floor								

- Note 1: For emissions in restricted bands, the limit of 15.209 was used. For all other emissions, the limit was set 20dB below the level of the fundamental and measured in 100kHz.
- Note 2: Signal is not in a restricted band but the more stringent restricted band limit was used.
- Note 3: Signal is only present when Bluetooth is enabled, average correction for hopping occupancy could be applied

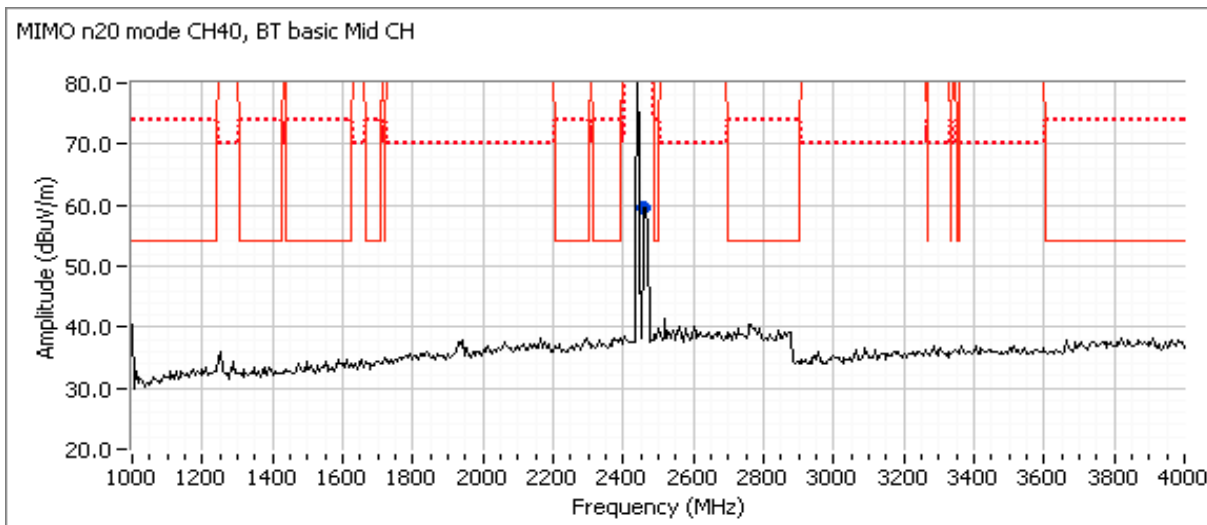

Client: Intel Corporation	Job Number: J94914
Model: 7265D2W	T-Log Number: T95472
Contact: Steve Hackett	Project Manager: Christine Krebill
Standard: FCC Part 15.247, 15.407, RSS-210	Project Coordinator: -
	Class: N/A

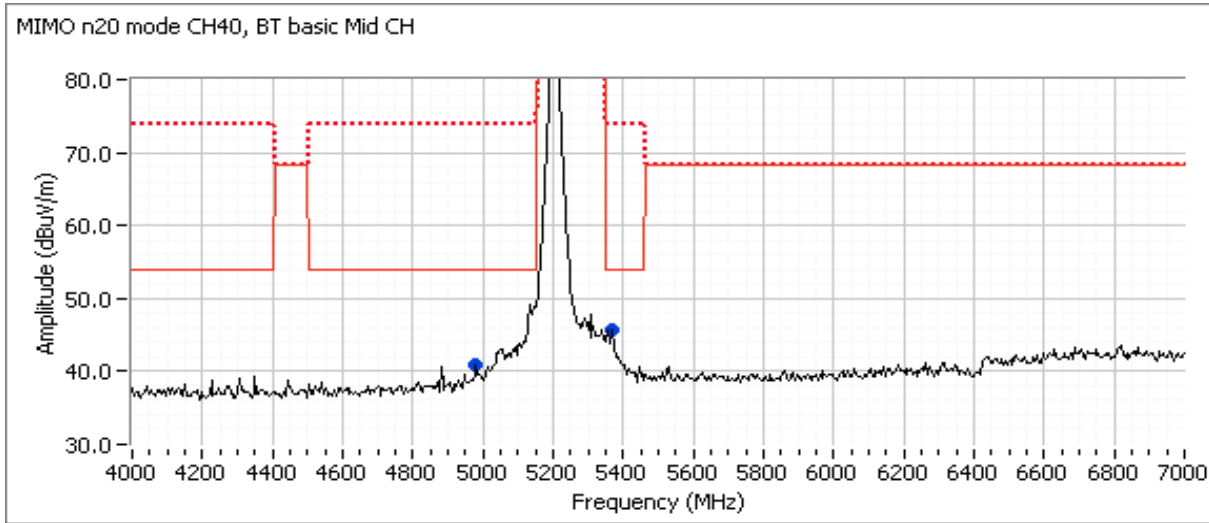

Run #12: 1-15GHz, 802.11n20 @ 5300 MHz Chain A+B, BT Basic Rate @ 2440 MHz Chain B
 Date of Test: 6/18/2014 Test Location: FT Chamber #4
 Test Engineer: R. Varelas Config Change: None

	Target (dBm)	Power Settings Measured (dBm)	Software Setting
WiFi A	16.0	16.6	32.0
WiFi B	16.0	16.5	33.0
Bluetooth	-	5.1	10.0

Note - measured power in table above is average power, for reference only.

Perform normal 7-15 GHz scan with filter for fundamental and then 1-4 and 4-7 GHz scans 20-30 cm from the product without filter.

Preliminary Measurements (Peak versus average limit)

Frequency	Level	Pol	15.209/15.247		Detector	Azimuth	Height	Comments
MHz	dB μ V/m	v/h	Limit	Margin	PK/QP/Avg	degrees	meters	
10599.970	42.3	H	68.3	-26.0	Peak	212	1.0	Harmonic of the EUT

Spurious Emissions (final measurements at 3m)

Frequency	Level	Pol	15.209 / 15.247		Detector	Azimuth	Height	Comments
MHz	dB μ V/m	v/h	Limit	Margin	PK/QP/Avg	degrees	meters	
refer to the spurious RE results								

Client:	Intel Corporation	Job Number:	J94914
Model:	7265D2W	T-Log Number:	T95472
Contact:	Steve Hackett	Project Manager:	Christine Krebill
Standard:	FCC Part 15.247, 15.407, RSS-210	Project Coordinator:	-
		Class:	N/A

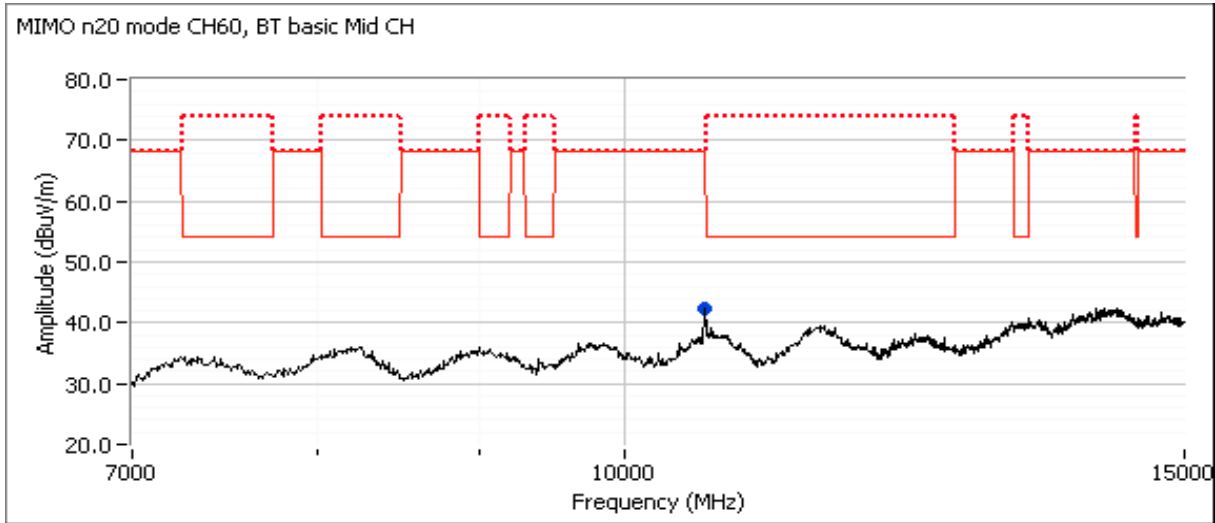

Preliminary Measurements (Peak versus average limit) at 20-30cm from EUT

Frequency	Level	Pol	15.209/15.247		Detector	Azimuth	Height	Comments
MHz	dBµV/m	v/h	Limit	Margin	Pk/QP/Avg	degrees	meters	
2460.000	63.3	V	120.0	-56.7	Peak	180	1.0	In band intermittent signal
5140.000	45.8	V	54.0	-8.2	Peak	180	1.0	
4880.000	42.0	V	54.0	-12.0	Peak	180	1.0	

Spurious Emissions (final measurements at 3m)

Frequency	Level	Pol	15.209 / 15.247		Detector	Azimuth	Height	Comments
MHz	dBµV/m	v/h	Limit	Margin	Pk/QP/Avg	degrees	meters	
no emissions found above the noise floor								

- Note 1: For emissions in restricted bands, the limit of 15.209 was used. For all other emissions, the limit was set 20dB below the level of the fundamental and measured in 100kHz.
- Note 2: Signal is not in a restricted band but the more stringent restricted band limit was used.
- Note 3: Signal is only present when Bluetooth is enabled, average correction for hopping occupancy could be applied

Client: Intel Corporation	Job Number: J94914
Model: 7265D2W	T-Log Number: T95472
Contact: Steve Hackett	Project Manager: Christine Krebill
Standard: FCC Part 15.247, 15.407, RSS-210	Project Coordinator: -
	Class: N/A

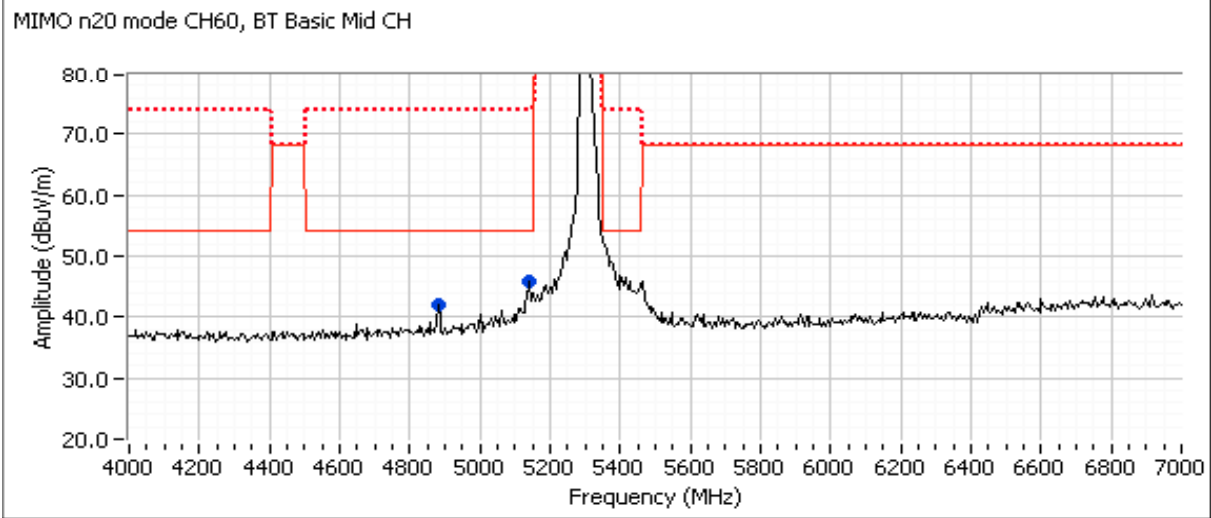
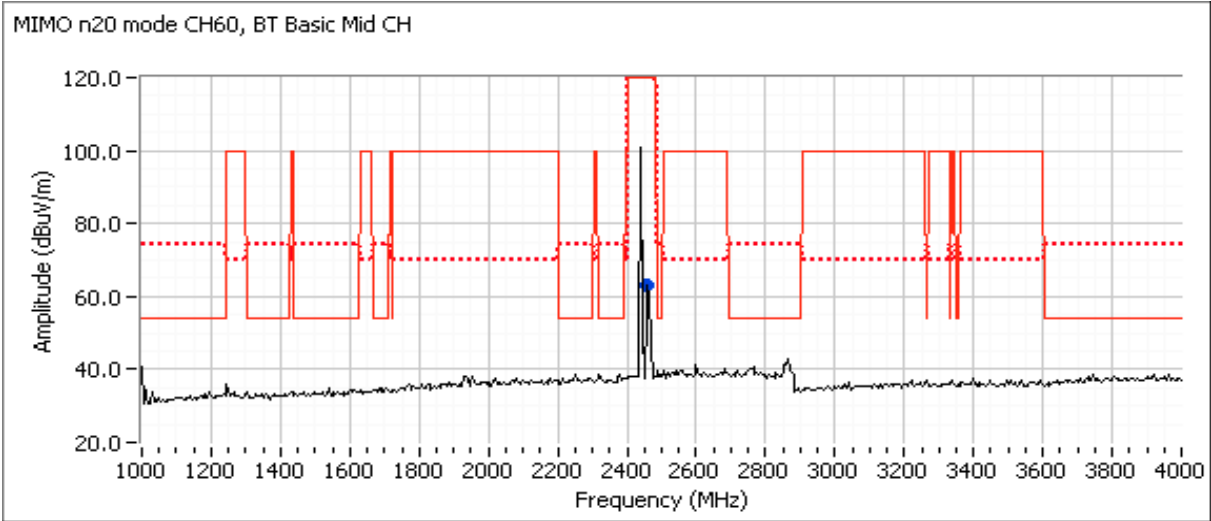



EMC Test Data

Client: Intel Corporation	Job Number: J94914
Model: 7265D2W	T-Log Number: T95472
Contact: Steve Hackett	Project Manager: Christine Krebill
Standard: FCC Part 15.247, 15.407, RSS-210	Project Coordinator: -
	Class: N/A

Run #13: 1-15GHz, 802.11n20 @ 5580 MHz Chain A+B, BT Basic Rate @ 2440 MHz Chain B
 Date of Test: 6/18/2014 Test Location: FT Chamber #4
 Test Engineer: R. Varelas Config Change: None

	Target (dBm)	Power Settings Measured (dBm)	Software Setting
WiFi A	16.0	16.6	28.5
WiFi B	16.0	16.5	29.5
Bluetooth	-	5.1	10.0

Note - measured power in table above is average power, for reference only.

Perform normal 7-15 GHz scan with filter for fundamental and then 1-4 and 4-7 GHz scans 20-30 cm from the product without filter.

Preliminary Measurements (Peak versus average limit)

Frequency	Level	Pol	15.209/15.247		Detector	Azimuth	Height	Comments
MHz	dB μ V/m	v/h	Limit	Margin	Pk/QP/Avg	degrees	meters	
11167.600	40.4	V	54.0	-13.6	Peak	165	1.0	Harmonic of the EUT

Spurious Emissions (final measurements at 3m)

Frequency	Level	Pol	15.209 / 15.247		Detector	Azimuth	Height	Comments
MHz	dB μ V/m	v/h	Limit	Margin	Pk/QP/Avg	degrees	meters	
refer to the spurious RE results								

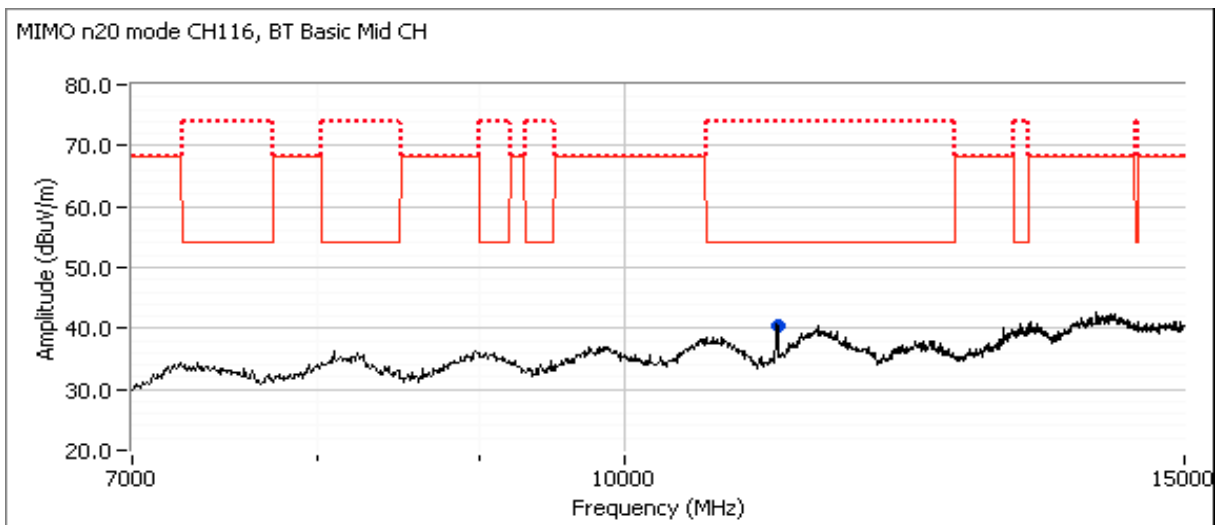

Client:	Intel Corporation	Job Number:	J94914
Model:	7265D2W	T-Log Number:	T95472
Contact:	Steve Hackett	Project Manager:	Christine Krebill
Standard:	FCC Part 15.247, 15.407, RSS-210	Project Coordinator:	-
		Class:	N/A

Preliminary Measurements (Peak versus average limit) at 20-30cm from EUT

Frequency	Level	Pol	15.209/15.247		Detector	Azimuth	Height	Comments
MHz	dB μ V/m	v/h	Limit	Margin	Pk/QP/Avg	degrees	meters	
4880.000	43.5	V	54.0	-10.5	Peak	180	1.0	
5425.000	46.2	V	54.0	-7.8	Peak	180	1.0	
2460.000	59.8	V	120.0	-60.2	Peak	180	1.0	In band intermittent signal

Spurious Emissions (final measurments at 3m)

Frequency	Level	Pol	15.209 / 15.247		Detector	Azimuth	Height	Comments
MHz	dB μ V/m	v/h	Limit	Margin	Pk/QP/Avg	degrees	meters	
no emisissions found above the noise floor								

- Note 1: For emissions in restricted bands, the limit of 15.209 was used. For all other emissions, the limit was set 20dB below the level of the fundamental and measured in 100kHz.
- Note 2: Signal is not in a restricted band but the more stringent restricted band limit was used.
- Note 3: Signal is only present when Bluetooth is enabled, average correction for hopping occupancy could be applied

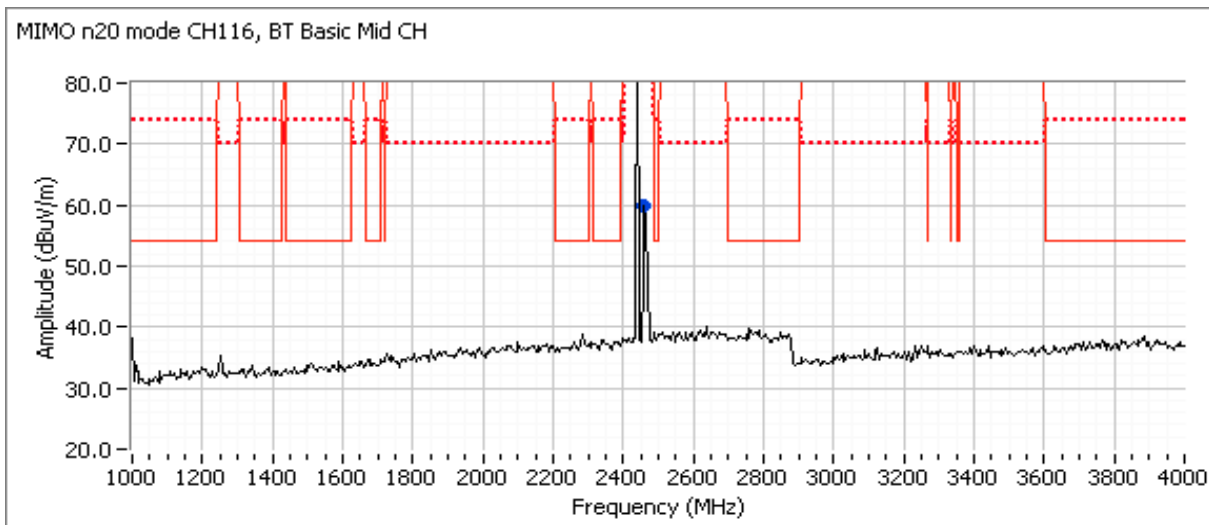



EMC Test Data

Client: Intel Corporation	Job Number: J94914
Model: 7265D2W	T-Log Number: T95472
Contact: Steve Hackett	Project Manager: Christine Krebill
Standard: FCC Part 15.247, 15.407, RSS-210	Project Coordinator: -
	Class: N/A

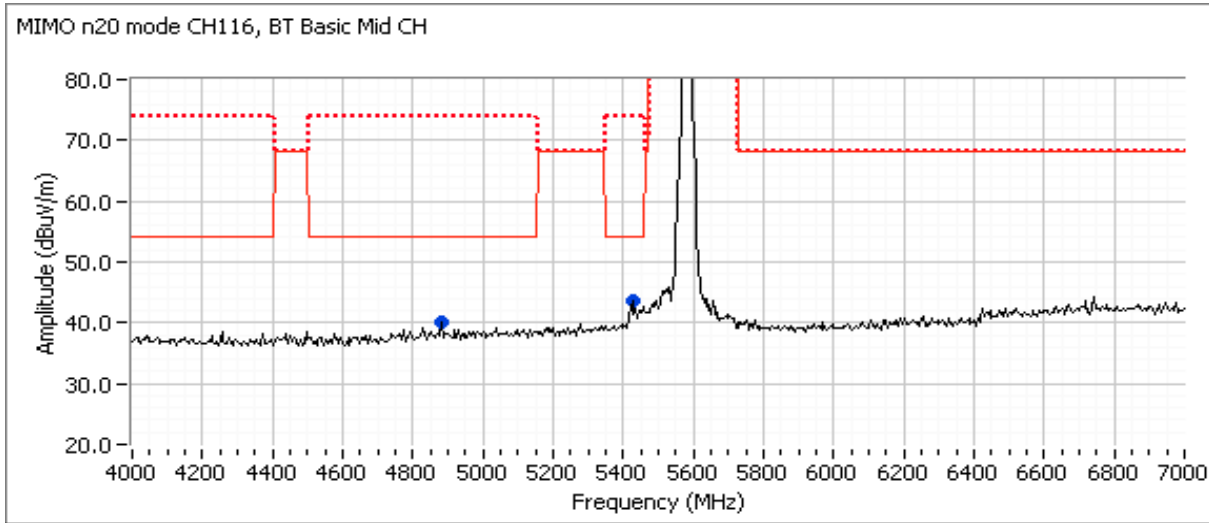

Run #14: 1-15GHz, 802.11n20 @ 5785 MHz Chain A+B, BT Basic Rate @ 2440 MHz Chain B
 Date of Test: 6/18/2014 Test Location: FT Chamber #4
 Test Engineer: R. Varelas Config Change: None

	Target (dBm)	Power Settings Measured (dBm)	Software Setting
WiFi A	16.0	16.7	34.5
WiFi B	16.0	16.5	35.5
Bluetooth	-	5.1	10.0

Note - measured power in table above is average power, for reference only.

Perform normal 7-15 GHz scan with filter for fundamental and then 1-4 and 4-7 GHz scans 20-30 cm from the product without filter.

Preliminary Measurements (Peak versus average limit)

Frequency	Level	Pol	15.209/15.247		Detector	Azimuth	Height	Comments
MHz	dB μ V/m	v/h	Limit	Margin	PK/QP/Avg	degrees	meters	
11570.260	46.3	V	54.0	-7.7	Peak	101	1.0	Harmonic of the EUT

Spurious Emissions (final measurements at 3m)

Frequency	Level	Pol	15.209 / 15.247		Detector	Azimuth	Height	Comments
MHz	dB μ V/m	v/h	Limit	Margin	PK/QP/Avg	degrees	meters	
refer to the spurious RE results								

Client: Intel Corporation	Job Number: J94914
Model: 7265D2W	T-Log Number: T95472
Contact: Steve Hackett	Project Manager: Christine Krebill
Standard: FCC Part 15.247, 15.407, RSS-210	Project Coordinator: -
	Class: N/A

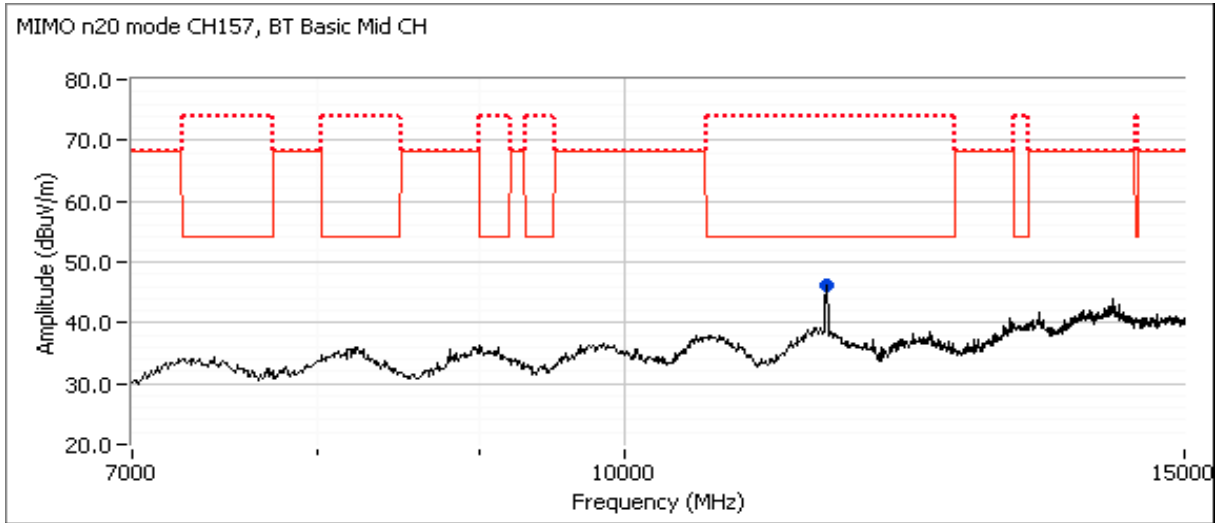

Preliminary Measurements (Peak versus average limit) at 20-30cm from EUT

Frequency	Level	Pol	15.209/15.247		Detector	Azimuth	Height	Comments
MHz	dBµV/m	v/h	Limit	Margin	PK/QP/Avg	degrees	meters	
2460.000	52.8	V	120.0	-67.2	Peak	180	1.0	In band intermittent signal

Spurious Emissions (final measurements at 3m)

Frequency	Level	Pol	15.209 / 15.247		Detector	Azimuth	Height	Comments
MHz	dBµV/m	v/h	Limit	Margin	PK/QP/Avg	degrees	meters	
Emissions is in band								

- Note 1: For emissions in restricted bands, the limit of 15.209 was used. For all other emissions, the limit was set 20dB below the level of the fundamental and measured in 100kHz.
- Note 2: Signal is not in a restricted band but the more stringent restricted band limit was used.
- Note 3: Signal is only present when Bluetooth is enabled, average correction for hopping occupancy could be applied

Client: Intel Corporation	Job Number: J94914
Model: 7265D2W	T-Log Number: T95472
Contact: Steve Hackett	Project Manager: Christine Krebill
Standard: FCC Part 15.247, 15.407, RSS-210	Project Coordinator: -
	Class: N/A

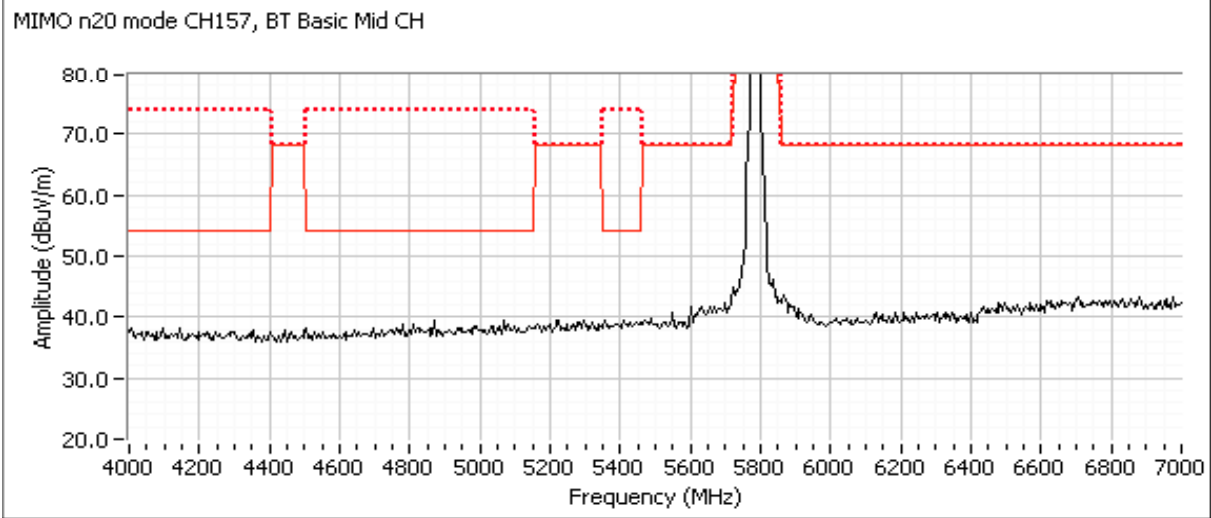
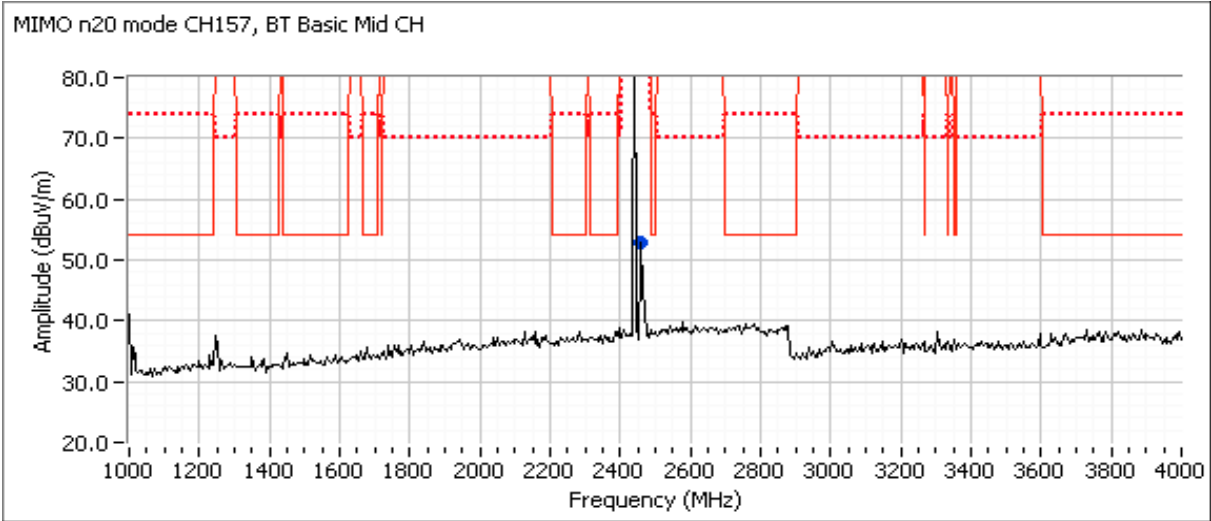



EMC Test Data

Client:	Intel Corporation	Job Number:	J94914
Model:	7265D2W	T-Log Number:	T95472
Contact:	Steve Hackett	Project Manager:	Christine Krebill
Standard:	FCC Part 15.247, 15.407, RSS-210	Project Coordinator:	-
		Class:	N/A

Radiated Emissions

(Elliott Laboratories Fremont Facility, Semi-Anechoic Chamber)

Test Specific Details

Objective: The objective of this test session is to perform final qualification testing of the EUT with respect to the specification listed above.

Date of Test: 6/17/2014
 Test Engineer: John Caizzi
 Test Location: Chamber 4

Config. Used: 1
 Config Change: none
 Host Unit Voltage 120V/60Hz

General Test Configuration

The EUT and any local support equipment were located on the turntable for radiated emissions testing. The test distance and extrapolation factor (if applicable) are detailed under each run description.

Note, preliminary testing indicates that the emissions were maximized by orientation of the EUT and elevation of the measurement antenna. Maximized testing indicated that the emissions were maximized by orientation of the EUT, elevation of the measurement

Ambient Conditions:

Temperature: 23 °C
 Rel. Humidity: 31 %

Summary of Results

MAC Address: 001500F15B3A, DRTU Tool Version 1.7.3-935, Driver version 17.1.0.11

Run #	Test Performed	Limit	Result	Margin
2	Radiated Emissions 30 - 1000 MHz, Maximized	FCC 15.209 / RSS 210	Pass	30.9 dBµV/m @ 112.94 MHz (-12.6 dB)
4	Radiated Emissions 30 - 1000 MHz, Maximized	FCC 15.209 / RSS 210	Pass	See above

Note - measurements with the WiFi and BT transmitters both operating indicate that the radiated emissions from the combination of test fixture and EUT are not affected by the module's operating frequency or mode. Additional channels and modes were therefore not necessary to show compliance with the limits.

Modifications Made During Testing

No modifications were made to the EUT during testing

Deviations From The Standard

No deviations were made from the requirements of the standard.



EMC Test Data

Client: Intel Corporation	Job Number: J94914
Model: 7265D2W	T-Log Number: T95472
Contact: Steve Hackett	Project Manager: Christine Krebill
Standard: FCC Part 15.247, 15.407, RSS-210	Project Coordinator: -
	Class: N/A

Run #1: Preliminary Radiated Emissions, 30 - 1000 MHz

Configured to Tx , 802.11b, 16.5 dBm on chain A (setting = 13.5) on channel 6, Bluetooth 5.1 dBm, 1Mb/s (setting 10 dBm) on channel 0

Test Parameters for Preliminary Scan(s)			
Frequency Range	Prescan Distance	Limit Distance	Extrapolation Factor
30 - 1000 MHz	3	3	0.0

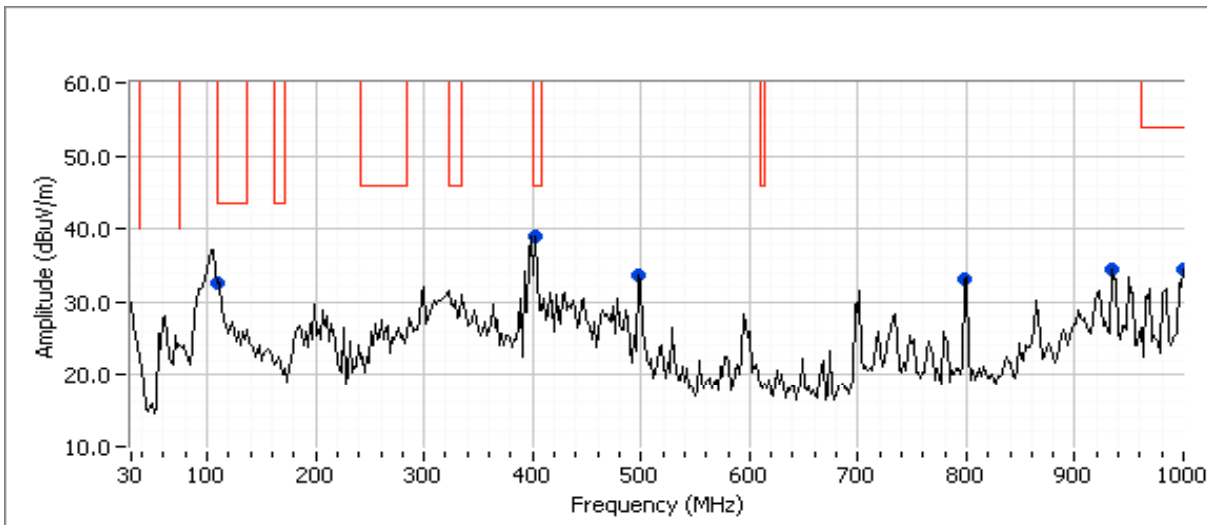

Preliminary peak readings captured during pre-scan

Frequency MHz	Level dBµV/m	Pol v/h	FCC 15.209 / RSS 210		Detector Pk/QP/Avg	Azimuth degrees	Height meters	Comments
			Limit	Margin				
112.935	32.7	V	43.5	-10.8	Peak	330	1.0	
399.925	38.9	H	46.0	-7.1	Peak	178	1.0	
497.952	33.8	H	46.0	-12.2	Peak	193	1.0	Note 1
799.457	33.2	V	46.0	-12.8	Peak	236	1.0	Note 1
933.500	34.6	H	46.0	-11.4	Peak	247	1.0	Note 1
999.347	34.5	V	54.0	-19.5	Peak	176	1.0	



EMC Test Data

Client:	Intel Corporation	Job Number:	J94914
Model:	7265D2W	T-Log Number:	T95472
Contact:	Steve Hackett	Project Manager:	Christine Krebill
Standard:	FCC Part 15.247, 15.407, RSS-210	Project Coordinator:	-
		Class:	N/A

Preliminary quasi-peak readings (no manipulation of EUT interface cables)

Frequency	Level	Pol	FCC 15.209 / RSS 210		Detector	Azimuth	Height	Comments
MHz	dB μ V/m	v/h	Limit	Margin	Pk/QP/Avg	degrees	meters	
112.935	30.9	V	43.5	-12.6	QP	45	1.00	
933.500	32.4	H	46.0	-13.6	QP	245	1.58	Note 1
799.457	30.6	V	46.0	-15.4	QP	151	1.04	Note 1
497.952	32.2	H	46.0	-13.8	QP	198	1.00	Note 1
399.925	33.3	H	46.0	-12.7	QP	182	1.00	
999.347	32.4	V	54.0	-21.6	QP	179	1.00	

Note 1: Emission in non-restricted band, but limit of 15.209 used.

Run #2: Maximized Readings From Run #1

Test Parameters for Maximized Reading(s)			
Frequency Range	Test Distance	Limit Distance	Extrapolation Factor
30 - 1000 MHz	3	3	0.0

Maximized quasi-peak readings (includes manipulation of EUT interface cables)

Frequency	Level	Pol	FCC 15.209 / RSS 210		Detector	Azimuth	Height	Comments
MHz	dB μ V/m	v/h	Limit	Margin	Pk/QP/Avg	degrees	meters	
112.935	30.9	V	43.5	-12.6	QP	45	1.00	
933.500	32.4	H	46.0	-13.6	QP	245	1.58	Note 1
799.457	30.6	V	46.0	-15.4	QP	151	1.04	Note 1
497.952	32.2	H	46.0	-13.8	QP	198	1.00	Note 1
399.925	33.3	H	46.0	-12.7	QP	182	1.00	
999.347	32.4	V	54.0	-21.6	QP	179	1.00	

Note 1: Emission in non-restricted band, but limit of 15.209 used.



EMC Test Data

Client: Intel Corporation	Job Number: J94914
Model: 7265D2W	T-Log Number: T95472
Contact: Steve Hackett	Project Manager: Christine Krebill
Standard: FCC Part 15.247, 15.407, RSS-210	Project Coordinator: -
	Class: N/A

Run #3: Preliminary Radiated Emissions, 30 - 1000 MHz
 Configured to Tx , 802.11a, 16.5 dBm on each chain (settings 25.5, 26.0) on channel 116, Bluetooth 4.7 dBm, 1Mb/s (setting 10 dBm) on Channel 78.

Test Parameters for Preliminary Scan(s)			
Frequency Range	Prescan Distance	Limit Distance	Extrapolation Factor
30 - 1000 MHz	3	3	0.0

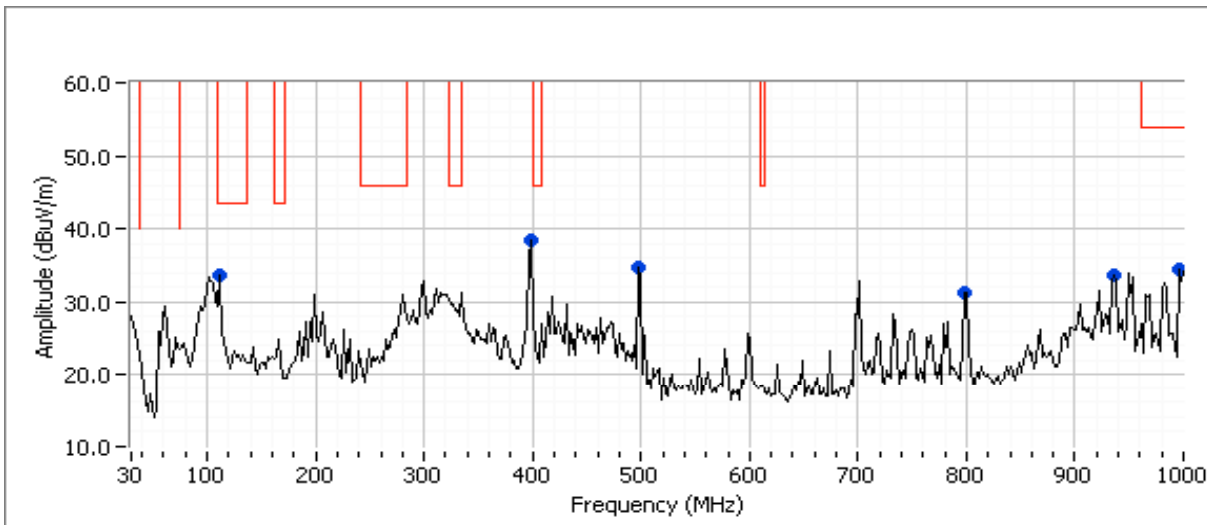

Preliminary peak readings captured during pre-scan

Frequency MHz	Level dB μ V/m	Pol v/h	FCC 15.209 / RSS 210		Detector Pk/QP/Avg	Azimuth degrees	Height meters	Comments
			Limit	Margin				
111.643	33.8	H	43.5	-9.7	Peak	89	3.0	
399.339	38.5	H	46.0	-7.5	Peak	169	1.0	Note 1
498.477	34.8	H	46.0	-11.2	Peak	199	1.0	Note 1
797.836	31.4	H	46.0	-14.6	Peak	79	1.0	Note 1
935.852	33.7	H	46.0	-12.3	Peak	249	1.0	Note 1
996.112	34.4	H	54.0	-19.6	Peak	319	1.0	

Note 1: Emission in non-restricted band, but limit of 15.209 used.



EMC Test Data

Client:	Intel Corporation	Job Number:	J94914
Model:	7265D2W	T-Log Number:	T95472
Contact:	Steve Hackett	Project Manager:	Christine Krebill
Standard:	FCC Part 15.247, 15.407, RSS-210	Project Coordinator:	-
		Class:	N/A

Preliminary quasi-peak readings (no manipulation of EUT interface cables)

Frequency	Level	Pol	FCC 15.209 / RSS 210		Detector	Azimuth	Height	Comments
MHz	dB μ V/m	v/h	Limit	Margin	Pk/QP/Avg	degrees	meters	

Run #4: Maximized Readings From Run #3

Test Parameters for Maximized Reading(s)			
Frequency Range	Test Distance	Limit Distance	Extrapolation Factor
30 - 1000 MHz	3	3	0.0

Maximized quasi-peak readings (includes manipulation of EUT interface cables)

Frequency	Level	Pol	FCC 15.209 / RSS 210		Detector	Azimuth	Height	Comments
MHz	dB μ V/m	v/h	Limit	Margin	Pk/QP/Avg	degrees	meters	



EMC Test Data

Client:	Intel Corporation	Job Number:	J94914
Model:	7265D2W	T-Log Number:	T95472
Contact:	Steve Hackett	Project Manager:	Christine Krebill
Standard:	FCC Part 15.247, 15.407, RSS-210	Project Coordinator:	-
		Class:	N/A

Conducted Emissions

(Elliott Laboratories Fremont Facility, Semi-Anechoic Chamber)

Test Specific Details

Objective: The objective of this test session is to perform final qualification testing of the EUT with respect to the specification listed above.

Date of Test: 6/20/2014
 Test Engineer: Jack Liu
 Test Location: FT Chamber# 4

Config. Used: 1
 Config Change: None
 Host Unit Voltage 120V/60Hz

General Test Configuration

The EUT on the test fixture and other support equipment was located on a wooden table inside the semi-anechoic chamber, 40 cm from a vertical coupling plane and 80cm from the LISN. A second LISN was used for all local support equipment. Remote support

Ambient Conditions:

Temperature: 24 °C
 Rel. Humidity: 38 %

Summary of Results

Run #	Test Performed	Limit	Result	Margin
1	CE, AC Power, 120V/60Hz	RSS 210 / 15.207	Pass	62.0 dBµV @ 0.152 MHz (-3.9 dB)

Modifications Made During Testing

No modifications were made to the EUT during testing

Deviations From The Standard

No deviations were made from the requirements of the standard.

Sample Notes

MAC Address: 001500F15B3A DRTU Tool Version 1.7.3-935 Driver version 17.1.0.11

Client: Intel Corporation	Job Number: J94914
Model: 7265D2W	T-Log Number: T95472
Contact: Steve Hackett	Project Manager: Christine Krebill
Standard: FCC Part 15.247, 15.407, RSS-210	Project Coordinator: -
	Class: N/A

Run #1: AC Power Port Conducted Emissions, 0.15 - 30MHz, 120V/60Hz
 Configured to Tx , 802.11a, 16.5 dBm on each chain (settings 25.5, 26.0) on channel 116, Bluetooth 5.1dBm, 1Mb/s (setting 10 dBm) on Mid Channel (2440MHz).

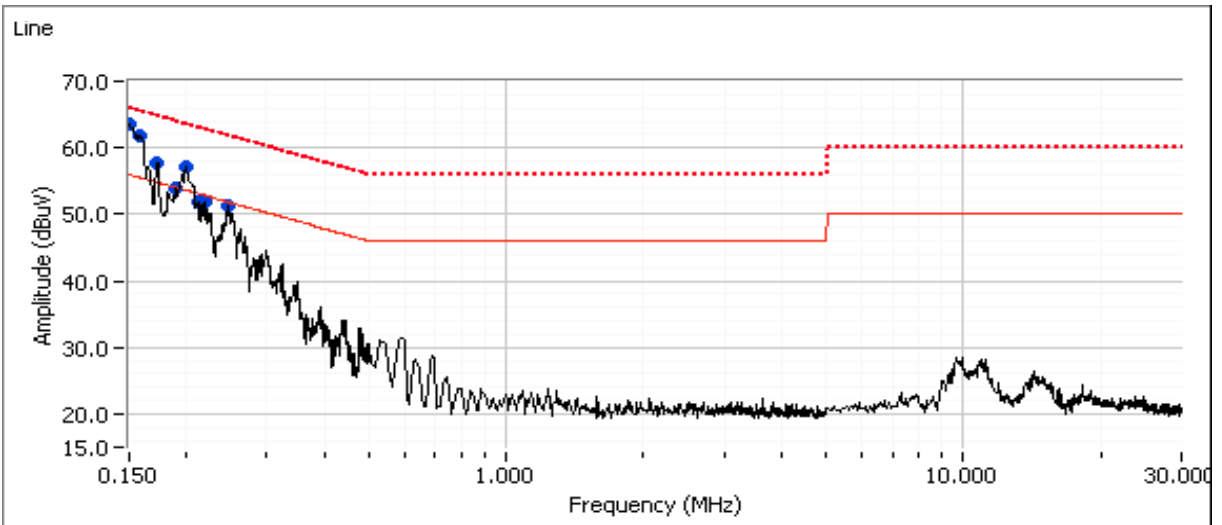
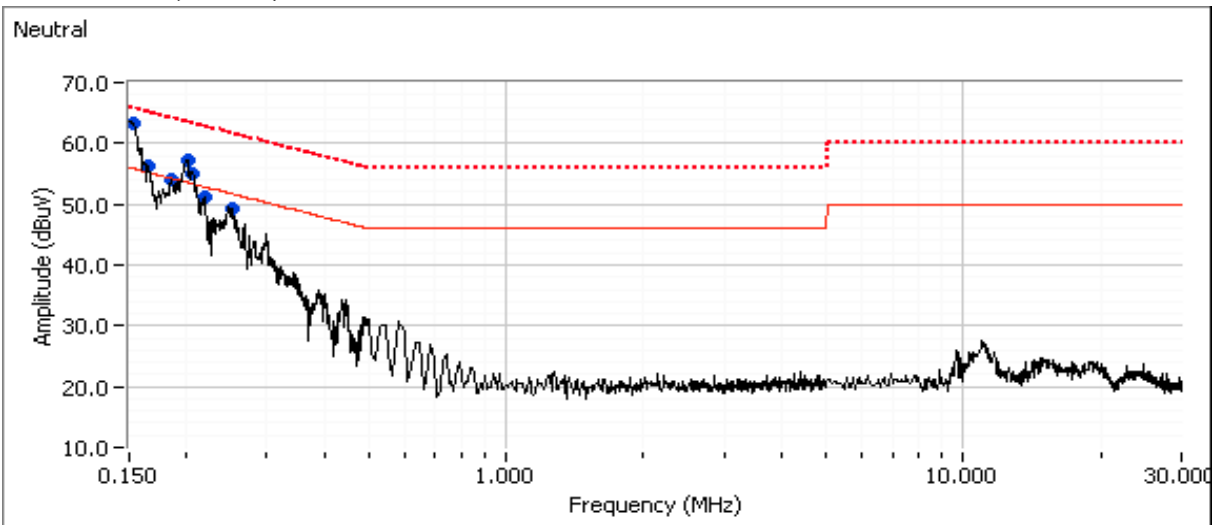



EMC Test Data

Client:	Intel Corporation	Job Number:	J94914
Model:	7265D2W	T-Log Number:	T95472
Contact:	Steve Hackett	Project Manager:	Christine Krebill
Standard:	FCC Part 15.247, 15.407, RSS-210	Project Coordinator:	-
		Class:	N/A

Preliminary peak readings captured during pre-scan (peak readings vs. average limit)

Frequency MHz	Level dB μ V	AC Line	RSS 210 / 15.207		Detector QP/Ave	Comments
			Limit	Margin		
0.200	57.1	Neutral	53.6	3.5	Peak	
0.150	63.2	Neutral	55.8	7.4	Peak	
0.162	56.2	Neutral	55.2	1.0	Peak	
0.188	53.9	Neutral	54.2	-0.3	Peak	
0.207	55.0	Neutral	53.3	1.7	Peak	
0.219	51.3	Neutral	52.9	-1.6	Peak	
0.251	49.3	Neutral	51.7	-2.4	Peak	
0.152	63.6	Line	56.0	7.6	Peak	
0.160	61.9	Line	55.6	6.3	Peak	
0.174	57.7	Line	54.8	2.9	Peak	
0.198	57.0	Line	53.6	3.4	Peak	
0.190	54.0	Line	54.0	0.0	Peak	
0.210	52.0	Line	53.1	-1.1	Peak	
0.222	51.9	Line	52.8	-0.9	Peak	
0.246	51.2	Line	51.9	-0.7	Peak	



EMC Test Data

Client:	Intel Corporation	Job Number:	J94914
Model:	7265D2W	T-Log Number:	T95472
Contact:	Steve Hackett	Project Manager:	Christine Krebill
Standard:	FCC Part 15.247, 15.407, RSS-210	Project Coordinator:	-
		Class:	N/A

Final quasi-peak and average readings

Frequency MHz	Level dB μ V	AC Line	RSS 210 / 15.207		Detector QP/Ave	Comments
			Limit	Margin		
0.152	62.0	Line	65.9	-3.9	QP	QP (1.00s)
0.152	47.8	Line	55.9	-8.1	AVG	AVG (0.10s)
0.200	54.7	Neutral	63.6	-8.9	QP	QP (1.00s)
0.198	54.4	Line	63.7	-9.3	QP	QP (1.00s)
0.160	46.1	Line	55.5	-9.4	AVG	AVG (0.10s)
0.160	56.0	Line	65.5	-9.5	QP	QP (1.00s)
0.162	55.3	Neutral	65.4	-10.1	QP	QP (1.00s)
0.210	51.6	Line	63.2	-11.6	QP	QP (1.00s)
0.190	52.3	Line	64.0	-11.7	QP	QP (1.00s)
0.162	43.1	Neutral	55.4	-12.3	AVG	AVG (0.10s)
0.174	51.9	Line	64.8	-12.9	QP	QP (1.00s)
0.150	52.9	Neutral	66.0	-13.1	QP	QP (1.00s)
0.207	50.1	Neutral	63.3	-13.2	QP	QP (1.00s)
0.200	39.6	Neutral	53.6	-14.0	AVG	AVG (0.10s)
0.188	50.1	Neutral	64.1	-14.0	QP	QP (1.00s)
0.246	47.7	Line	61.9	-14.2	QP	QP (1.00s)
0.251	47.2	Neutral	61.7	-14.5	QP	QP (1.00s)
0.174	39.2	Line	54.8	-15.6	AVG	AVG (0.10s)
0.198	37.9	Line	53.7	-15.8	AVG	AVG (0.10s)
0.210	36.8	Line	53.2	-16.4	AVG	AVG (0.10s)
0.150	39.0	Neutral	56.0	-17.0	AVG	AVG (0.10s)
0.219	45.2	Neutral	62.9	-17.7	QP	QP (1.00s)
0.222	44.8	Line	62.7	-17.9	QP	QP (1.00s)
0.207	34.7	Neutral	53.3	-18.6	AVG	AVG (0.10s)
0.251	32.0	Neutral	51.7	-19.7	AVG	AVG (0.10s)
0.190	34.2	Line	54.0	-19.8	AVG	AVG (0.10s)
0.188	34.1	Neutral	54.1	-20.0	AVG	AVG (0.10s)
0.219	32.5	Neutral	52.9	-20.4	AVG	AVG (0.10s)
0.246	31.5	Line	51.9	-20.4	AVG	AVG (0.10s)
0.222	30.9	Line	52.7	-21.8	AVG	AVG (0.10s)

End of Report

This page is intentionally blank and marks the last page of this test report.