



SPORTON International Inc.

No.8, Lane 724, Bo-ai St., Jhubei City, HsinChu County 302, Taiwan, R.O.C.
Ph: 886-3-656-9065 / FAX: 886-3-656-9085 / www.sporton.com.tw

FCC / IC RADIO TEST REPORT

Applicant's company	Intel Corporation
Applicant Address	100 Center Point Circle Suite 200 Columbia, SC 29210
FCC ID	PD962205ANSU
IC	1000M-62205ANSU
Manufacturer's company	Intel Corporation
Manufacturer Address	2111 NE 25th Avenue, Hillsboro, OR 97124 USA

Product Name	Intel Centrino Advanced-N 6205
Brand Name	Intel
Model Name	62205ANSFF
Test Rule Part(s)	47 CFR FCC Part 15 Subpart E § 15.407 RSS 210 Issue 8 Industry Canada RSS-Gen Issue 3
Test Freq. Range	5150 ~ 5350MHz / 5470 ~ 5725MHz
Received Date	Dec. 01, 2011
Final Test Date	Dec. 26, 2011
Submission Type	Original Equipment
Operating Mode	Client (without radar detection function)

Statement

Test result included is for the IEEE 802.11n and IEEE 802.11a (5150 ~ 5350MHz / 5470 ~ 5725MHz) of the product.

The test result in this report refers exclusively to the presented test model / sample. Without written approval of SPORTON International Inc., the test report shall not be reproduced except in full.

The measurements and test results shown in this test report were made in accordance with the procedures and found in compliance with the limit given in ANSI C63.10-2009 and 47 CFR FCC Part 15 Subpart E, RSS 210 Issue 8 and Industry Canada RSS-Gen Issue 3.

The test equipment used to perform the test is calibrated and traceable to NML/ROC.





SPORTON International Inc.

No.8, Lane 724, Bo-ai St., Jhubei City, HsinChu County 302, Taiwan, R.O.C.
Ph: 886-3-656-9065 / FAX: 886-3-656-9085 / www.sporton.com.tw

Table of Contents

1. CERTIFICATE OF COMPLIANCE	1
2. SUMMARY OF THE TEST RESULT	2
3. GENERAL INFORMATION	4
3.1. Product Details.....	4
3.2. Accessories.....	6
3.3. Table for Filed Antenna.....	6
3.4. Table for Carrier Frequencies	7
3.5. Table for Test Modes	8
3.6. Table for Testing Locations.....	9
3.7. Table for the EUT consisted of the following component(s).....	9
3.8. Table for Supporting Units	9
3.9. EUT OPERATION.....	10
3.10. Test Configurations	11
4. TEST RESULT	13
4.1. AC Power Line Conducted Emissions Measurement.....	13
4.2. Band Edge Emissions Measurement	17
4.3. 99% Occupied Bandwidth Measurement	53
4.4. Maximum Conducted Output Power Measurement.....	69
4.5. Power Spectral Density Measurement	80
4.6. Peak Excursion Measurement.....	96
4.7. Radiated Emissions Measurement for Transmitter and Receiver Spurious	112
4.8. Frequency Stability Measurement	134
4.9. Antenna Requirements	136
5. LIST OF MEASURING EQUIPMENTS	137
6. TEST LOCATION.....	139
7. TAF CERTIFICATE OF ACCREDITATION	140
APPENDIX A. TEST PHOTOS	A1 ~ A6
APPENDIX B. MAXIMUM PERMISSIBLE EXPOSURE	B1 ~ B3



History of This Test Report

REPORT NO.	VERSION	DESCRIPTION	ISSUED DATE
FR&CR1D1211AA	Rev. 01	Initial issue of report	Jan. 18, 2012



1. CERTIFICATE OF COMPLIANCE

Product Name : Intel Centrino Advanced-N 6205
Brand Name : Intel
Model Name : 62205ANSFF
Applicant : Intel Corporation
Test Rule Part(s) : 47 CFR FCC Part 15 Subpart E § 15.407
RSS 210 Issue 8
Industry Canada RSS-Gen Issue 3

Sporton International as requested by the applicant to evaluate the EMC performance of the product sample received on Dec. 01, 2011 would like to declare that the tested sample has been evaluated and found to be in compliance with the tested rule parts. The data recorded as well as the test configuration specified is true and accurate for showing the sample's EMC nature.

A handwritten signature in blue ink that reads 'Jordan Hsiao'. The signature is written in a cursive style and is positioned above a horizontal line.

Jordan Hsiao

SPORTON INTERNATIONAL INC.

2. SUMMARY OF THE TEST RESULT

Applied Standard: 47 CFR FCC Part 15 Subpart E / RSS 210 Issue 8 / Industry Canada RSS-Gen Issue 3					
Part	FCC Rule Part	RSS Rule Part	Description of Test	Measure Value/ Comments	Result
4.1	15.207	RSS GEN Table 2	AC Power Line Conducted Emissions	49.79dB μ V @ 0.19758MHz	Complies
4.2	15.407(b)	-	Band Edge Emissions	65.97dB μ V/m @ 5470MHz	Complies
4.3	15.407(a)	-	26dB Bandwidth	Band 1: 802.11a: 26.08 MHz MCS0 (20MHz): 28.16 MHz ; MCS0 (40MHz): 42.24 MHz Band 2: 802.11a: 25.12 MHz MCS0 (20MHz): 28.80 MHz ; MCS0 (40MHz): 47.36 MHz Band 3: 802.11a: 34.08 MHz MCS0 (20MHz): 39.04 MHz ; MCS0 (40MHz): 66.24 MHz	Complies
4.3	-	RSP 100 RSS GEN 4.4.1	99% Spectrum Bandwidth	Band 1: 802.11a: 16.96 MHz MCS0 (20MHz): 18.08 MHz ; MCS0 (40MHz): 36.16 MHz Band 2: 802.11a: 16.96 MHz MCS0 (20MHz): 18.24 MHz ; MCS0 (40MHz): 36.16 MHz Band 3: 802.11a: 17.60 MHz MCS0 (20MHz): 18.72 MHz ; MCS0 (40MHz): 36.48 MHz	
4.4	15.407(a)	A9.2(2)	Maximum Conducted Output Power	Band 1: 802.11a: 15.66 dBm MCS0 (20MHz): 16.20 dBm ; MCS0 (40MHz): 15.68 dBm Band 2: 802.11a: 15.68 dBm MCS0 (20MHz): 16.12 dBm ; MCS0 (40MHz): 15.64 dBm Band 3: 802.11a: 16.08 dBm MCS0 (20MHz): 16.58 dBm ; MCS0 (40MHz): 16.10 dBm	Complies
4.5	15.407(a)	A9.2(2) / A9.5 (2)	Power Spectral Density	2.97 dBm / 3kHz	Complies
4.6	15.407(a)	-	Peak Excursion	12.48 dB	Complies
4.7	15.407(b)	A9.3	Radiated Emissions	39.30dB μ V/m @ 900.09MHz	Complies
4.8	15.407(g)	A9.5 (5)	Frequency Stability	-	Complies
4.9	15.203	-	Antenna Requirements	-	Complies

Note: Dynamic frequency Selection (device without radar detection) refer to separate test report, reference Sporton test report: FZ&CZ1D1211.

Test Items	Uncertainty	Remark
AC Power Line Conducted Emissions	±2.3dB	Confidence levels of 95%
Maximum Conducted Output Power	±0.5dB	Confidence levels of 95%
Power Spectral Density	±0.5dB	Confidence levels of 95%
Peak Excursion	±0.5dB	Confidence levels of 95%
26dB Spectrum Bandwidth / Frequency Stability	±8.5×10 ⁻⁸	Confidence levels of 95%
Radiated Emissions (9kHz~30MHz)	±0.8dB	Confidence levels of 95%
Radiated Emissions (30MHz~1000MHz)	±1.9dB	Confidence levels of 95%
Radiated / Band Edge Emissions (1GHz~18GHz)	±1.9dB	Confidence levels of 95%
Radiated Emissions (18GHz~40GHz)	±1.9dB	Confidence levels of 95%
Temperature	±0.7°C	Confidence levels of 95%
Humidity	±3.2%	Confidence levels of 95%
DC / AC Power Source	±1.4%	Confidence levels of 95%

3. GENERAL INFORMATION

3.1. Product Details

IEEE 802.11n

Items	Description
Product Type	WLAN (1TX, 1RX/ 2TX, 2RX)
Radio Type	Intentional Transceiver
Power Type	From Host System
Modulation	see the below table for IEEE 802.11n
Data Modulation	OFDM (BPSK / QPSK / 16QAM / 64QAM)
Data Rate (Mbps)	see the below table for IEEE 802.11n
Frequency Range	5150 ~ 5350MHz / 5470 ~ 5725MHz
Channel Number	19 for 20MHz bandwidth ; 9 for 40MHz bandwidth
Channel Band Width (99%)	Band 1: MCS0 (20MHz): 18.08 MHz ; MCS0 (40MHz): 36.16 MHz Band 2: MCS0 (20MHz): 18.24 MHz ; MCS0 (40MHz): 36.16 MHz Band 3: MCS0 (20MHz): 18.72 MHz ; MCS0 (40MHz): 36.48 MHz
Conducted Output Power	Band 1: MCS0 (20MHz): 16.20 dBm ; MCS0 (40MHz): 15.68 dBm Band 2: MCS0 (20MHz): 16.12 dBm ; MCS0 (40MHz): 15.64 dBm Band 3: MCS0 (20MHz): 16.58 dBm ; MCS0 (40MHz): 16.10 dBm
Carrier Frequencies	Please refer to section 3.4
Antenna	Please refer to section 3.3

IEEE 802.11a

Items	Description
Product Type	WLAN (1TX, 1RX)
Radio Type	Intentional Transceiver
Power Type	From Host System
Modulation	OFDM for IEEE 802.11a
Data Modulation	OFDM (BPSK / QPSK / 16QAM / 64QAM)
Data Rate (Mbps)	OFDM (6/9/12/18/24/36/48/54)
Frequency Range	5150 ~ 5350MHz / 5470 ~ 5725MHz
Channel Number	19
Channel Band Width (99%)	Band 1: 16.96 MHz ; Band 2: 16.96 MHz ; Band 3: 17.60 MHz
Conducted Output Power	Band 1: 15.66 dBm ; Band 2: 15.68 dBm ; Band 3: 16.08 dBm
Carrier Frequencies	Please refer to section 3.4
Antenna	Please refer to section 3.3

Antenna & Band width

Antenna	Single (TX)		Two (TX)	
	20 MHz	40 MHz	20 MHz	40 MHz
IEEE 802.11a	V	X	X	X
IEEE 802.11n	V	V	V	V

IEEE 802.11n spec

MCS Index	Nss	Modulation	R	NBPS	NCBPS		NDBPS		Datarate(Mbps)			
					20MHz	40MHz	20MHz	40MHz	800nsGI		400nsGI	
									20MHz	40MHz	20MHz	40MHz
0	1	BPSK	1/2	1	52	108	26	54	6.5	13.5	7.200	15
1	1	QPSK	1/2	2	104	216	52	108	13.0	27.0	14.400	30
2	1	QPSK	3/4	2	104	216	78	162	19.5	40.5	21.700	45
3	1	16-QAM	1/2	4	208	432	104	216	26.0	54.0	28.900	60
4	1	16-QAM	3/4	4	208	432	156	324	39.0	81.0	43.300	90
5	1	64-QAM	2/3	6	312	648	208	432	52.0	108.0	57.800	120
6	1	64-QAM	3/4	6	312	648	234	486	58.5	121.5	65.000	135
7	1	64-QAM	5/6	6	312	648	260	540	65.0	135.0	72.200	150
8	2	BPSK	1/2	1	104	216	52	108	13.0	27.0	14.444	30
9	2	QPSK	1/2	2	208	432	104	216	26.0	54.0	28.889	60
10	2	QPSK	3/4	2	208	432	156	324	39.0	81.0	43.333	90
11	2	16-QAM	1/2	4	416	864	208	432	52.0	108.0	57.778	120
12	2	16-QAM	3/4	4	416	864	312	648	78.0	162.0	86.667	180
13	2	64-QAM	2/3	6	624	1296	416	864	104.0	216.0	115.556	240
14	2	64-QAM	3/4	6	624	1296	468	972	117.0	243.0	130.000	270
15	2	64-QAM	5/6	6	624	1296	520	1080	130.0	270.0	144.444	300

Symbol	Explanation
NSS	Number of spatial streams
R	Code rate
NBPS	Number of coded bits per single carrier
NCBPS	Number of coded bits per symbol
NDBPS	Number of data bits per symbol
GI	guard interval

3.2. Accessories

N/A

3.3. Table for Filed Antenna

Ant.	Brand	Model Name	Antenna Type	Connector	Gain (dBi)			
					2.4GHz	5GHz		
						5.15~5.35 GHz	5.47~5.725 GHz	5.725~5.850 GHz
A	Shanghai Universe Communication Electron Co., Ltd.	N/A	PIFA Antenna	UFL	3.2	3.7	4.8	5
B	Shanghai Universe Communication Electron Co., Ltd.	N/A	PIFA Antenna	UFL	3.2	3.7	4.8	5

Note: There are two sets of antenna provided to this EUT and all of them can be used as transmitting and receiving antenna

For IEEE 802.11n mode (2TX/2RX)

Antenna A and Antenna B could transmit/receive simultaneously.

For IEEE 802.11n mode (1TX/1RX)

The EUT supports the antenna with TX/RX diversity function.

For IEEE 802.11a mode (1TX/1RX):

The EUT supports the antenna with TX/RX diversity function.

3.4. Table for Carrier Frequencies

For IEEE 802.11a, use Channel 36, 40, 44, 48, 52, 56, 60, 64, 100, 104, 108, 112, 116, 120, 124, 128, 132, 136, 140.

There are two bandwidth systems for IEEE 802.11n.

For both 20MHz bandwidth systems, use Channel 36, 40, 44, 48, 52, 56, 60, 64, 100, 104, 108, 112, 116, 120, 124, 128, 132, 136, 140.

For both 40MHz bandwidth systems, use Channel 38, 46, 54, 62, 102, 110, 118, 126, 134.

Frequency Band	Channel No.	Frequency	Channel No.	Frequency
5150~5250 MHz Band 1	36	5180 MHz	44	5220 MHz
	38	5190 MHz	46	5230 MHz
	40	5200 MHz	48	5240 MHz
5250~5350 MHz Band 2	52	5260 MHz	60	5300 MHz
	54	5270 MHz	62	5310 MHz
	56	5280 MHz	64	5320 MHz
5470~5725 MHz Band 3	100	5500 MHz	120	5600 MHz
	102	5510MHz	124	5620 MHz
	104	5520 MHz	126	5630 MHz
	108	5540 MHz	128	5640 MHz
	110	5550 MHz	132	5660 MHz
	112	5560 MHz	134	5670 MHz
	116	5580 MHz	136	5680 MHz
	118	5590 MHz	140	5700 MHz

3.5. Table for Test Modes

In normal operating modes the card uses power settings stored on EEPROM to set the output power. For a given nominal output power the actual transmit power is reduced as the data rate increases, therefore testing was performed at the lowest data rate in each mode as this data rate to determine compliance with the requirements at the highest power setting.

The following power measurements were made using an average power meter and with the device configured in a continuous transmit mode on Chain A at the various data rates in each mode to verify this:

Mode	Setting	Date Rate	Power
802.11a	17.5	6	13.82
		9	13.76
		12	13.72
		18	13.74
		24	13.61
		36	13.53
		48	13.54
		54	13.51
802.11n 20MHz	18.5	6.5	14.63
		13	14.47
		19.5	14.53
		26	14.48
		39	14.41
		52	14.35
		58.5	14.33
		65	14.30
802.11n 40MHz	14	13.5	9.62
		27	9.60
		40.5	9.47
		54	9.25
		81	9.24
		108	9.19
		121.5	9.20
		135	9.09

3.6. Table for Testing Locations

Test Site No.	Site Category	Location	FCC Reg. No.	IC File No.	VCCI Reg. No
03CH01-CB	SAC	Hsin Chu	262045	IC 4086D	-
CO01-CB	Conduction	Hsin Chu	262045	IC 4086D	-
TH01-CB	OVEN Room	Hsin Chu	-	-	-

Open Area Test Site (OATS); Semi Anechoic Chamber (SAC); Fully Anechoic Chamber (FAC).

Please refer section 6 for Test Site Address.

3.7. Table for the EUT consisted of the following component(s)

Manufacturer	Model Name	Description	MAC address	FCC ID / IC UPN
Intel Corporation	62205ANSFF	PCIe Half Mini Card 802.11a/b/g/n wireless network	00:15:00:85:80:1C	PD962205ANSU 1000M-62205ANSU

3.8. Table for Supporting Units

Support Unit	Brand	Model	FCC ID
PC	DELL	T3400	N/A
LCD Monitor	HP	FW660AA	DoC
Mouse	iCooky	AMS0706W	DoC
Keyboard	iCooky	SK068	DoC

3.9. EUT OPERATION

The EUT was installed into a test fixture that exposed all sides of the card. The test fixture interfaced to a laptop computer and dc power supply. The laptop computer was used to configure the EUT to continuously transmit at a specified output power or continuously receive on the channel specified in the test data. For transmit mode measurements the system was configured to operate in each of the available operating modes – 802.11b, 802.11g, 802.11a, 802.11n (20 MHz channel bandwidth) and 802.11n (40MHz channel bandwidth).

Legacy modes (SISO-only) were evaluated on each chain individually. The 802.11n modes were evaluated operating on each chain separately (SISO) and on both chains simultaneously (MIMO). Spurious measurements, other than band-edge measurements, were only performed on 802.11n modes with both chains transmitting simultaneously. For those tests the output power per chain was set to the higher single-chain power level to cover both SISO and MIMO operation.

The data rates used for all tests were the lowest data rates for each mode – 1Mb/s for 802.11b, 6Mb/s for 802.11a and 802.11g, 6.5MB/s for 802.11n (20MHz), and 13 Mb/s for 802.11n (40MHz). The device operates at its maximum output power at the lowest data rate (this was confirmed through separate measurements – refer to test data for actual measurements).

The PC was using the Intel test utility DRTU Version 1.5.2-0308 and the device driver was version 14.0.4.115.

3.10. Test Configurations

3.10.1. Radiation Emissions Test Configuration

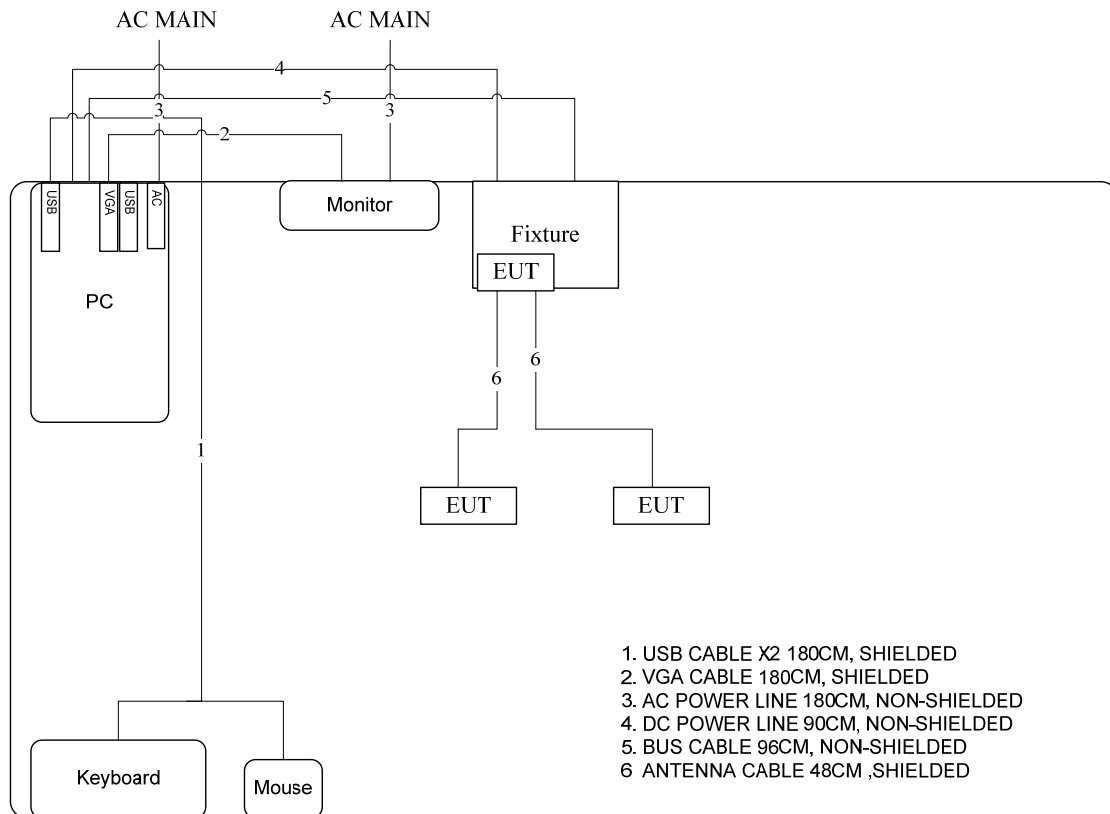

3.10.2. AC Power Line Conduction Emissions Test Configuration

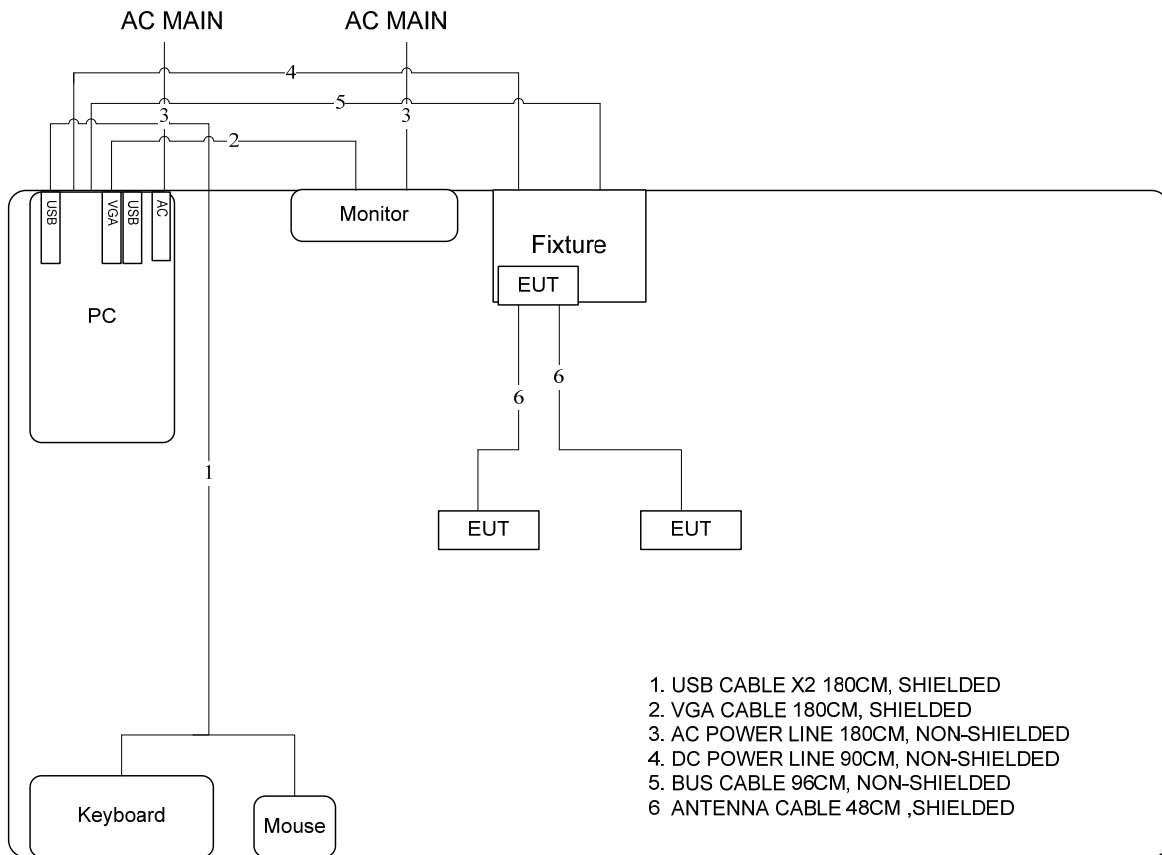

4. TEST RESULT

4.1. AC Power Line Conducted Emissions Measurement

4.1.1. Summary of Test Results

MAC Address: 00:15:00:85:80:1C DRTU Tool Version: 1.5.2-0308 Driver version: 14.0.4.115

Test #	Test Performed	Limit	Result	Under Limit (dB)
1	CE, AC Power, 120V/60Hz	FCC 15.207/RSS GEN	Pass	3.92dB

4.1.2. Limit

For this product that is designed to connect to the AC power line, the radio frequency voltage that is conducted back onto the AC power line on any frequency or frequencies within the band 150 kHz to 30 MHz shall not exceed below limits table.

Frequency (MHz)	QP Limit (dBuV)	AV Limit (dBuV)
0.15~0.5	66~56	56~46
0.5~5	56	46
5~30	60	50

4.1.3. Measuring Instruments and Setting

Please refer to section 5 of equipments list in this report. The following table is the setting of the receiver.

Receiver Parameters	Setting
Attenuation	10 dB
Start Frequency	0.15 MHz
Stop Frequency	30 MHz
IF Bandwidth	9 KHz

4.1.4. Test Procedures

1. Configure the EUT according to ANSI C63.10. The EUT or host of EUT has to be placed 0.4 meter far from the conducting wall of the shielding room and at least 80 centimeters from any other grounded conducting surface.
2. Connect EUT or host of EUT to the power mains through a line impedance stabilization network (LISN).
3. All the support units are connected to the other LISNs. The LISN should provide 50uH/50ohms coupling impedance.
4. The frequency range from 150 KHz to 30 MHz was searched.
5. Set the test-receiver system to Peak Detect Function and Specified Bandwidth with Maximum Hold Mode.
6. The measurement has to be done between each power line and ground at the power terminal.

4.1.5. Test Setup Layout

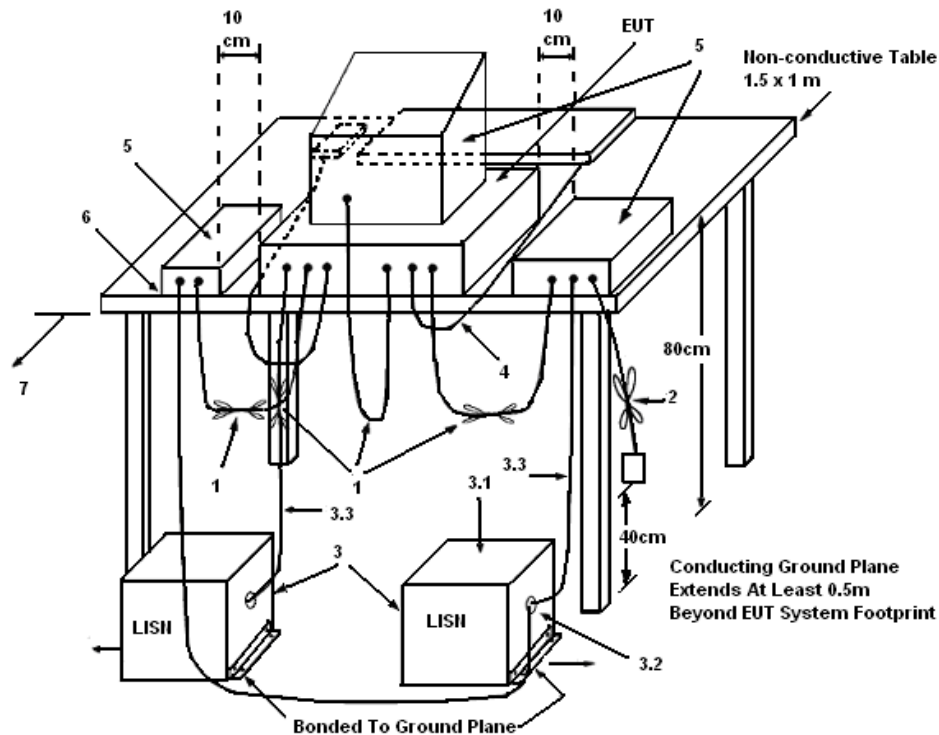

LEGEND:

- (1) Interconnecting cables that hang closer than 40 cm to the ground plane shall be folded back and forth in the center forming a bundle 30 to 40 cm long.
- (2) I/O cables that are not connected to a peripheral shall be bundled in the center. The end of the cable may be terminated, if required, using the correct terminating impedance. The overall length shall not exceed 1 m.
- (3) EUT connected to one LISN. Unused LISN measuring port connectors shall be terminated in 50 Ω . LISN can be placed on top of, or immediately beneath, reference ground plane.
 - (3.1) All other equipment powered from additional LISN(s).
 - (3.2) Multiple outlet strip can be used for multiple power cords of non-EUT equipment.
 - (3.3) LISN at least 80 cm from nearest part of EUT chassis.
- (4) Cables of hand-operated devices, such as keyboards, mice, etc., shall be placed as for normal use.
- (5) Non-EUT components of EUT system being tested.
- (6) Rear of EUT, including peripherals, shall all be aligned and flush with rear of tabletop.
- (7) Rear of tabletop shall be 40 cm removed from a vertical conducting plane that is bonded to the ground plane.

4.1.6. Test Deviation

There is no deviation with the original standard.

4.1.7. EUT Operation during Test

The EUT was placed on the test table and programmed in normal function.

4.1.8. Results of AC Power Line Conducted Emissions Measurement

Temperature	22°C	Humidity	61%
Test Engineer	Simon Yang	Phase	Line
Configuration	CTX		

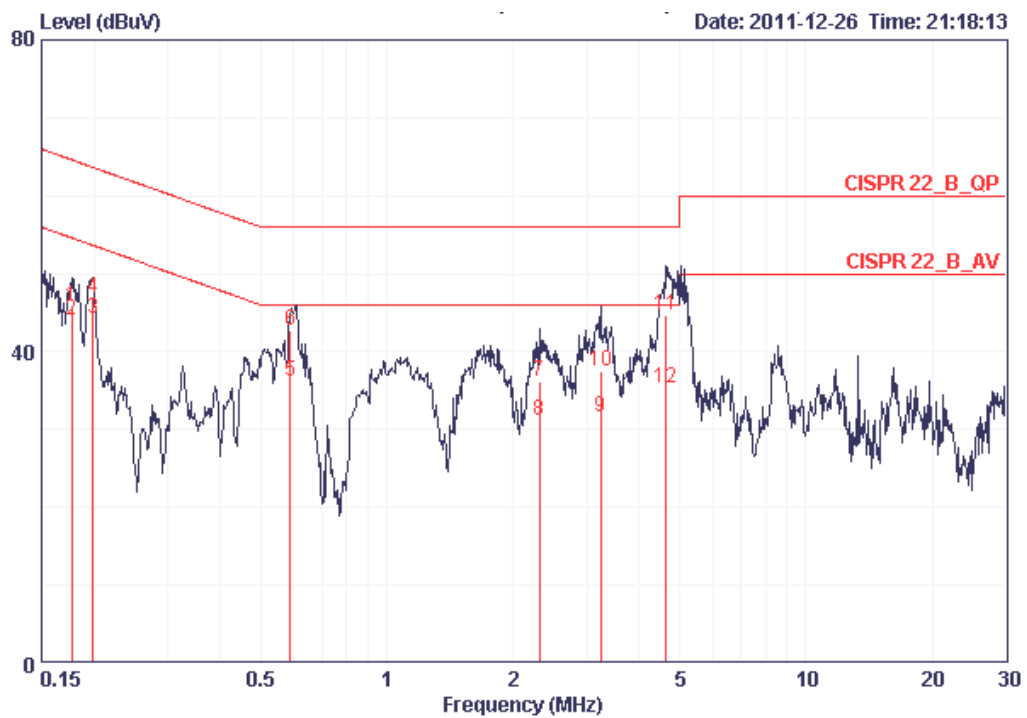

	Freq	Level	Over Limit	Limit Line	Read Level	LISN Factor	Cable Loss	Remark
	MHz	dBuV	dB	dBuV	dBuV	dB	dB	
1	0.17678	45.75	-18.89	64.64	45.49	0.06	0.20	QP
2	0.17678	44.12	-10.52	54.64	43.86	0.06	0.20	AVERAGE
3	0.19863	44.27	-9.40	53.67	44.02	0.05	0.20	AVERAGE
4	0.19863	46.78	-16.89	63.67	46.53	0.05	0.20	QP
5	0.58925	36.21	-9.79	46.00	35.98	0.03	0.20	AVERAGE
6	0.58925	42.70	-13.30	56.00	42.47	0.03	0.20	QP
7	2.309	36.20	-19.80	56.00	35.94	0.06	0.20	QP
8	2.309	31.20	-14.80	46.00	30.94	0.06	0.20	AVERAGE
9	3.241	31.59	-14.41	46.00	31.25	0.08	0.25	AVERAGE
10	3.241	37.59	-18.41	56.00	37.25	0.08	0.25	QP
11	4.622	44.75	-11.25	56.00	44.31	0.14	0.30	QP
12	4.622	35.21	-10.79	46.00	34.77	0.14	0.30	AVERAGE

Temperature	22°C	Humidity	61%
Test Engineer	Simon Yang	Phase	Neutral
Configuration	CTX		

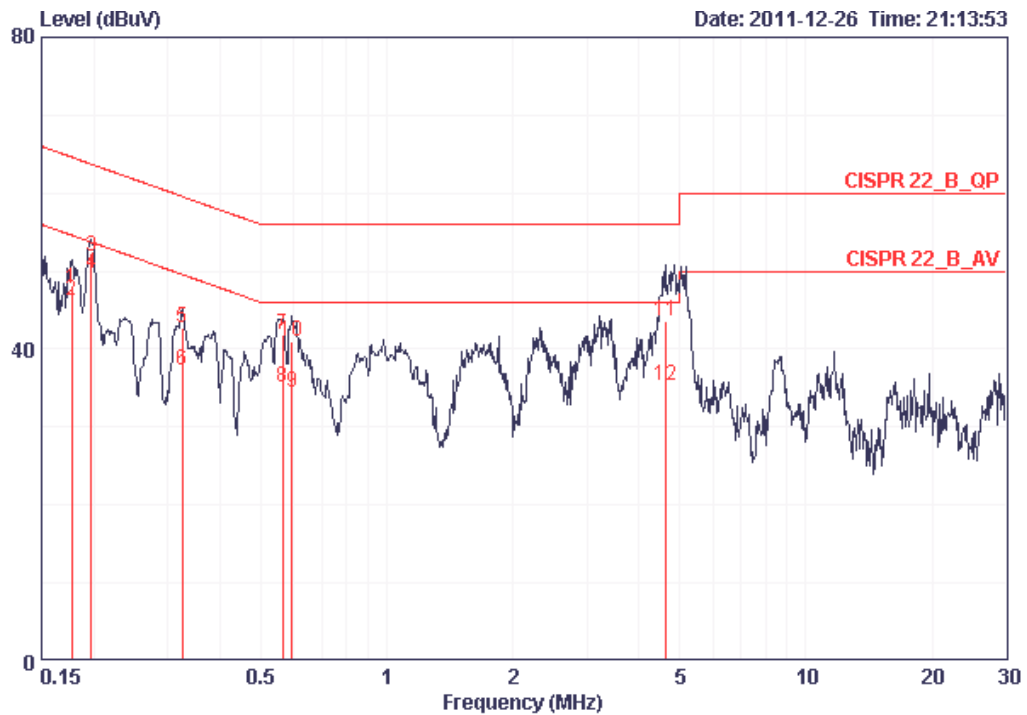

	Freq	Level	Over Limit	Limit Line	Read Level	LISN Factor	Cable Loss	Remark
	MHz	dBuV	dB	dBuV	dBuV	dB	dB	
1	0.17678	47.80	-16.84	64.64	47.51	0.09	0.20	QP
2	0.17678	46.32	-8.32	54.64	46.03	0.09	0.20	AVERAGE
3	0.19758	51.78	-11.93	63.71	51.50	0.08	0.20	QP
4	0.19758	49.79	-3.92	53.71	49.51	0.08	0.20	AVERAGE
5	0.32512	42.68	-16.89	59.57	42.41	0.07	0.20	QP
6	0.32512	37.23	-12.34	49.57	36.96	0.07	0.20	AVERAGE
7	0.56409	41.82	-14.18	56.00	41.55	0.07	0.20	QP
8	0.56409	35.18	-10.82	46.00	34.91	0.07	0.20	AVERAGE
9	0.59478	34.38	-11.62	46.00	34.11	0.07	0.20	AVERAGE
10	0.59478	41.00	-15.00	56.00	40.73	0.07	0.20	QP
11	4.622	43.56	-12.44	56.00	43.08	0.18	0.30	QP
12	4.622	35.42	-10.58	46.00	34.94	0.18	0.30	AVERAGE

Note:

Level = Read Level + LISN Factor + Cable Loss.

4.2. Band Edge Emissions Measurement

4.2.1. Summary of Test Results

MAC Address: 00:15:00:85:80:1C DRTU Tool Version: 1.5.2-0308 Driver version: 14.0.4.115

Test #	Mode	Channel	Target Power (dBm)	Measured Power (dBm)	Test Performed	Limit	Result	Margin (dB)
1	an 40MHz Chain A	#38 5190 MHz	10.5	10.4	Restricted Band Edge at 5150 MHz	15.209	PASS	-12.19
2		#62 5310 MHz	11	11.06	Restricted Band Edge at 5350 MHz		PASS	-10.98
3		#102 5510 MHz	13.5	13.43	Restricted Band Edge at 5460 MHz		PASS	-11.06
4		#134 5670 MHz	15.5	15.34	Band Edge at 5470 MHz	15E	PASS	-2.33
					Band Edge at 5725 MHz		PASS	-17.03
1	an 40MHz Chain B	#38 5190 MHz	10.5	10.38	Restricted Band Edge at 5150 MHz	15.209	PASS	-9.90
2		#62 5310 MHz	11	11.1	Restricted Band Edge at 5350 MHz		PASS	-9.92
3		#102 5510 MHz	13.5	13.47	Restricted Band Edge at 5460 MHz		PASS	-12.14
4		#134 5670 MHz	15.5	15.52	Band Edge at 5470 MHz	15E	PASS	-3.79
					Band Edge at 5725 MHz		PASS	-11.25
1	an 40MHz Chain A+B	#38 5190 MHz	A: 9 B: 9	A: 9.13 B: 9.20	Restricted Band Edge at 5150 MHz	15.209	PASS	-10.53
2		#62 5310 MHz	A: 9.5 B: 9.5	A: 9.44 B: 9.61	Restricted Band Edge at 5350 MHz		PASS	-11.18
3		#102 5510 MHz	A: 12.5 B: 12.5	A: 12.46 B: 12.40	Restricted Band Edge at 5460 MHz		PASS	-12.92
4		#134 5670 MHz	A: 13 B: 13	A: 12.92 B: 13.13	Band Edge at 5470 MHz	15E	PASS	-7.43
					Band Edge at 5725 MHz		PASS	-15.82

Test #	Mode	Channel	Target Power (dBm)	Measured Power (dBm)	Test Performed	Limit	Result	Margin (dB)
1	an 20MHz Chain A	#36 5180 MHz	15	15.2	Restricted Band Edge at 5150 MHz	15.209	PASS	-11.54
2		#64 5320 MHz	15.5	15.46	Restricted Band Edge at 5350 MHz		PASS	-12.08
3		#100 5500 MHz	16	15.93	Restricted Band Edge at 5460 MHz		PASS	-14.53
4		#140 5700 MHz	15.5	15.35	Band Edge at 5470 MHz	15E	PASS	-11.32
					Band Edge at 5725 MHz		PASS	-6.14
1	an 20MHz Chain B	#36 5180 MHz	15	14.95	Restricted Band Edge at 5150 MHz	15.209	PASS	-9.54
2		#64 5320 MHz	15.5	15.59	Restricted Band Edge at 5350 MHz		PASS	-11.44
3		#100 5500 MHz	16	15.89	Restricted Band Edge at 5460 MHz		PASS	-14.44
4		#140 5700 MHz	15.5	15.62	Band Edge at 5470 MHz	15E	PASS	-7.04
					Band Edge at 5725 MHz		PASS	-5.80
1	an 20MHz Chain A+B	#36 5180 MHz	A: 13 B: 13	A: 13.01 B: 13.01	Restricted Band Edge at 5150 MHz	15.209	PASS	-13.69
2		#64 5320 MHz	A: 13 B: 13	A: 13.1 B: 13.12	Restricted Band Edge at 5350 MHz		PASS	-12.95
3		#100 5500 MHz	A: 13 B: 13	A: 13.2 B: 13.2	Restricted Band Edge at 5460 MHz		PASS	-14.27
4		#140 5700 MHz	A: 13.5 B: 13.5	A: 13.55 B: 13.58	Band Edge at 5470 MHz	15E	PASS	-7.43
					Band Edge at 5725 MHz		PASS	-10.31
1	802.11a Chain A	#36 5180 MHz	15.5	15.48	Restricted Band Edge at 5150 MHz	15.209	PASS	-12.77
2		#64 5320 MHz	15	15	Restricted Band Edge at 5350 MHz		PASS	-13.76
3		#100 5500 MHz	16	16.08	Restricted Band Edge at 5460 MHz		PASS	-15.13
4		#140 5700 MHz	15.5	15.63	Band Edge at 5470 MHz	15E	PASS	-11.41
					Band Edge at 5725 MHz		PASS	-7.77
1	802.11a Chain B	#36 5180 MHz	15.5	15.53	Restricted Band Edge at 5150 MHz	15.209	PASS	-9.80
2		#64 5320 MHz	15	20	Restricted Band Edge at 5350 MHz		PASS	-12.26
3		#100 5500 MHz	16	22.5	Restricted Band Edge at 5460 MHz		PASS	-14.64
4		#140 5700 MHz	15.5	15.46	Band Edge at 5470 MHz	15E	PASS	-9.05
					Band Edge at 5725 MHz		PASS	-6.31

4.2.2. Limit

For transmitters operating in the 5.15-5.35 GHz band: all emissions outside of the 5.15-5.35 GHz band shall not exceed an EIRP of -27 dBm/MHz (68.3dBuV/m at 3m). For transmitters operating in the 5.470-5.725 GHz band: all emissions outside of the 5.470-5.725 GHz band shall not exceed an EIRP of -27 dBm/MHz (68.3dBuV/m at 3m). For transmitters operating in the 5.725-5.825 GHz band: all emissions within the frequency range from the band edge to 10 MHz above or below the band edge shall not exceed an EIRP of -17 dBm/MHz (78.3dBuV/m at 3m); for frequencies 10 MHz or greater above or below the band edge, emissions shall not exceed an EIRP of -27 dBm/MHz (68.3dBuV/m at 3m). In addition, In case the emission fall within the restricted band specified on 15.205(a), then the 15.209(a) limit in the table below has to be followed.

Frequencies (MHz)	Field Strength (microrvolts/meter)	Measurement Distance (meters)
0.009~0.490	2400/F(KHz)	300
0.490~1.705	24000/F(KHz)	30
1.705~30.0	30	30
30~88	100	3
88~216	150	3
216~960	200	3
Above 960	500	3

4.2.3. Measuring Instruments and Setting

Please refer to section 5 of equipments list in this report. The following table is the setting of the spectrum analyzer.

Spectrum Parameter	Setting
Attenuation	Auto
Span Frequency	100 MHz
RB / VB (Emission in restricted band)	1MHz / 1MHz for Peak, 1 MHz / 10Hz for Average
RB / VB (Emission in non-restricted band)	1 MHz / 1 MHz for Peak

4.2.4. Test Procedures

1. The test procedure is the same as section 4.6.3, only the frequency range investigated is limited to 100MHz around bandedges.
2. In case the emission is fail due to the used RB/VB is too wide, marker-delta method of FCC Public Notice DA00-705 will be followed.

4.2.5. Test Setup Layout

This test setup layout is the same as that shown in section 4.6.4.

4.2.6. Test Deviation

There is no deviation with the original standard.

4.2.7. EUT Operation during Test

The EUT was programmed to be in continuously transmitting mode.



4.2.8. Test Result of Band Edge and Fundamental Emissions

Date of Test:	Dec. 15, 2011
Test Engineer:	Denis Su

Test #1 EUT on Channel36 5180MHz - 802.11a, Chain A

Antenna Port	Target (dBm)	Power Settings Measured (dBm)	Software Setting
Chain A	15.5	15.48	17.5

Fundamental Signal Field Strength

Frequency	Level	Test Polar	15.209/15.407		Detector	Azimuth	Height	Comments
			Limit	Margin				
MHz	dBuV/m	V/H			PK/AV	degrees	meters	
5173.43	102.33	V	-	-	Peak	112	100	RB:1MHz;VB:3MHz;Detector:PK
5173.27	92.45	V	-	-	Avg	112	100	RB:1MHz;VB:10Hz;Detector:PK
5173.27	101.4	H	-	-	Peak	253	145	RB:1MHz;VB:3MHz;Detector:PK
5173.27	92.26	H	-	-	Avg	253	145	RB:1MHz;VB:10Hz;Detector:PK

Direct Measurement of Field Strength at the bandedge

Frequency	Level	Test Polar	15.209/15.407		Detector	Azimuth	Height	Comments
			Limit	Margin				
MHz	dBuV/m	V/H			PK/AV	degrees	meters	
5149.84	56.03	V	74	-17.97	Peak	112	100	RB:1MHz;VB:3MHz;Detector:PK
5150	40.81	V	54	-13.19	Avg	112	100	RB:1MHz;VB:10Hz;Detector:PK
5148.24	56.1	H	74	-17.9	Peak	253	145	RB:1MHz;VB:3MHz;Detector:PK
5150	41.23	H	54	-12.77	Avg	253	145	RB:1MHz;VB:10Hz;Detector:PK



Test #2 EUT on Channel64 5320MHz - 802.11a, Chain A

Antenna Port	Target (dBm)	Power Settings Measured (dBm)	Software Setting
Chain A	15	15	18.5

Fundamental Signal Field Strength

Frequency MHz	Level dBuV/m	Test Polar V/H	15.209/15.407		Detector PK/AV	Azimuth degrees	Height meters	Comments
			Limit	Margin				
5321.6	93.12	V	-	-	Peak	156	109	RB:1MHz;VB:3MHz;Detector:PK
5321.12	102.84	V	-	-	Avg	156	109	RB:1MHz;VB:10Hz;Detector:PK
5326.41	92.62	H	-	-	Peak	187	126	RB:1MHz;VB:3MHz;Detector:PK
5326.89	102.36	H	-	-	Avg	187	126	RB:1MHz;VB:10Hz;Detector:PK

Direct Measurement of Field Strength at the bandedge

Frequency MHz	Level dBuV/m	Test Polar V/H	15.209/15.407		Detector PK/AV	Azimuth degrees	Height meters	Comments
			Limit	Margin				
5350	55.03	V	74	-18.97	Peak	156	109	RB:1MHz;VB:3MHz;Detector:PK
5350	40.23	V	54	-13.77	Avg	156	109	RB:1MHz;VB:10Hz;Detector:PK
5350.64	53.07	H	74	-20.93	Peak	187	126	RB:1MHz;VB:3MHz;Detector:PK
5350	40.24	H	54	-13.76	Avg	187	126	RB:1MHz;VB:10Hz;Detector:PK



Test #3 EUT on Channel100 5500MHz - 802.11a, Chain A

Antenna Port	Target (dBm)	Power Settings Measured (dBm)	Software Setting
Chain A	16	16.08	21.5

Fundamental Signal Field Strength

Frequency MHz	Level dBuV/m	Test Polar V/H	15.209/15.407		Detector PK/AV	Azimuth degrees	Height meters	Comments
			Limit	Margin				
5506.89	100.35	V	-	-	Peak	52	1	RB:1MHz;VB:3MHz;Detector:PK
5507.05	90.36	V	-	-	Avg	52	1	RB:1MHz;VB:10Hz;Detector:PK
5495.83	100.98	H	-	-	Peak	346	1	RB:1MHz;VB:3MHz;Detector:PK
5494.87	90.46	H	-	-	Avg	346	1	RB:1MHz;VB:10Hz;Detector:PK

Direct Measurement of Field Strength at the bandedge

Frequency MHz	Level dBuV/m	Test Polar V/H	15.209/15.407		Detector PK/AV	Azimuth degrees	Height meters	Comments
			Limit	Margin				
5460	50.15	V	74	-23.85	Peak	52	1	RB:1MHz;VB:3MHz;Detector:PK
5468.56	55.09	V	68.3	-13.21	Peak	52	1	RB:1MHz;VB:3MHz;Detector:PK
5460	38.83	V	54	-15.17	Avg	52	1	RB:1MHz;VB:10Hz;Detector:PK
5459.84	50.82	H	74	-23.18	Peak	346	1	RB:1MHz;VB:3MHz;Detector:PK
5469.2	56.89	H	68.3	-11.41	Peak	346	1	RB:1MHz;VB:3MHz;Detector:PK
5460	38.87	H	54	-15.13	Avg	346	1	RB:1MHz;VB:10Hz;Detector:PK



Test #4 EUT on Channel140 5700MHz - 802.11a, Chain A

Antenna Port	Target (dBm)	Power Settings Measured (dBm)	Software Setting
Chain A	15.5	15.63	23.5

Fundamental Signal Field Strength

Frequency MHz	Level dBuV/m	Test Polar V/H	15.209/15.407		Detector PK/AV	Azimuth degrees	Height meters	Comments
			Limit	Margin				
5693.59	102.27	V	-	-	Peak	169	1	RB:1MHz;VB:3MHz;Detector:PK
5692.95	91.9	V	-	-	Avg	169	1	RB:1MHz;VB:10Hz;Detector:PK
5693.75	99.11	H	-	-	Peak	351	1.04	RB:1MHz;VB:3MHz;Detector:PK
5693.59	89.05	H	-	-	Avg	351	1.04	RB:1MHz;VB:10Hz;Detector:PK

Direct Measurement of Field Strength at the bandedge

Frequency MHz	Level dBuV/m	Test Polar V/H	15.209/15.407		Detector PK/AV	Azimuth degrees	Height meters	Comments
			Limit	Margin				
5725	60.53	V	68.3	-7.77	Peak	169	1	RB:1MHz;VB:3MHz;Detector:PK
5725.16	54.07	H	68.3	-14.23	Peak	351	1.04	RB:1MHz;VB:3MHz;Detector:PK



Date of Test:	Dec. 15, 2011
Test Engineer:	Denis Su

Test #1 EUT on Channel36 5180MHz - 802.11a, Chain B

Antenna Port	Target (dBm)	Power Settings Measured (dBm)	Software Setting
Chain B	15.5	15.53	20.5

Fundamental Signal Field Strength

Frequency	Level	Test Polar	15.209/15.407		Detector	Azimuth	Height	Comments
			Limit	Margin				
MHz	dBuV/m	V/H			PK/AV	degrees	meters	
5185.93	102.09	V	-	-	Peak	187	1	RB:1MHz;VB:3MHz;Detector:PK
5186.57	92.06	V	-	-	Avg	187	1	RB:1MHz;VB:10Hz;Detector:PK
5173.43	103.18	H	-	-	Peak	110	1.33	RB:1MHz;VB:3MHz;Detector:PK
5186.57	92.89	H	-	-	Avg	110	1.33	RB:1MHz;VB:10Hz;Detector:PK

Direct Measurement of Field Strength at the bandedge

Frequency	Level	Test Polar	15.209/15.407		Detector	Azimuth	Height	Comments
			Limit	Margin				
MHz	dBuV/m	V/H			PK/AV	degrees	meters	
5149.52	60.27	V	74	-13.73	Peak	187	1	RB:1MHz;VB:3MHz;Detector:PK
5150	44.14	V	54	-9.86	Avg	187	1	RB:1MHz;VB:10Hz;Detector:PK
5149.68	59.7	H	74	-14.3	Peak	110	1.33	RB:1MHz;VB:3MHz;Detector:PK
5150	44.2	H	54	-9.8	Avg	110	1.33	RB:1MHz;VB:10Hz;Detector:PK



Test #2 EUT on Channel64 5320MHz - 802.11a, Chain B

Antenna Port	Target (dBm)	Power Settings Measured (dBm)	Software Setting
Chain B	15	20	14.9

Fundamental Signal Field Strength

Frequency MHz	Level dBuV/m	Test Polar V/H	15.209/15.407		Detector PK/AV	Azimuth degrees	Height meters	Comments
			Limit	Margin				
5326.89	101.53	V	-	-	Peak	240	1	RB:1MHz;VB:3MHz;Detector:PK
5327.05	91.69	V	-	-	Avg	240	1	RB:1MHz;VB:10Hz;Detector:PK
5313.59	104.75	H	-	-	Peak	109	1.21	RB:1MHz;VB:3MHz;Detector:PK
5313.27	94.31	H	-	-	Avg	109	1.21	RB:1MHz;VB:10Hz;Detector:PK

Direct Measurement of Field Strength at the bandedge

Frequency MHz	Level dBuV/m	Test Polar V/H	15.209/15.407		Detector PK/AV	Azimuth degrees	Height meters	Comments
			Limit	Margin				
5350.16	54.32	V	74	-19.68	Peak	240	1	RB:1MHz;VB:3MHz;Detector:PK
5350	41.11	V	54	-12.89	Avg	240	1	RB:1MHz;VB:10Hz;Detector:PK
5350.8	55.57	H	74	-18.43	Peak	109	1.21	RB:1MHz;VB:3MHz;Detector:PK
5350	41.74	H	54	-12.26	Avg	109	1.21	RB:1MHz;VB:10Hz;Detector:PK



Test #3 EUT on Channel100 5500MHz - 802.11a, Chain B

Antenna Port	Target (dBm)	Power Settings Measured (dBm)	Software Setting
Chain B	16	22.5	16.02

Fundamental Signal Field Strength

Frequency MHz	Level dBuV/m	Test Polar V/H	15.209/15.407		Detector PK/AV	Azimuth degrees	Height meters	Comments
			Limit	Margin				
5493.43	104.17	V	-	-	Peak	201	1	RB:1MHz;VB:3MHz;Detector:PK
5493.59	93.4	V	-	-	Avg	201	1	RB:1MHz;VB:10Hz;Detector:PK
5493.59	105.66	H	-	-	Peak	111	1.67	RB:1MHz;VB:3MHz;Detector:PK
5493.43	95.23	H	-	-	Avg	111	1.67	RB:1MHz;VB:10Hz;Detector:PK

Direct Measurement of Field Strength at the bandedge

Frequency MHz	Level dBuV/m	Test Polar V/H	15.209/15.407		Detector PK/AV	Azimuth degrees	Height meters	Comments
			Limit	Margin				
5459.52	52.49	V	74	-21.51	Peak	201	1	RB:1MHz;VB:3MHz;Detector:PK
5468.88	57.74	V	68.3	-10.56	Peak	201	1	RB:1MHz;VB:3MHz;Detector:PK
5460	39.21	V	54	-14.79	Avg	201	1	RB:1MHz;VB:10Hz;Detector:PK
5459.68	52.09	H	74	-21.91	Peak	111	1.67	RB:1MHz;VB:3MHz;Detector:PK
5469.2	59.25	H	68.3	-9.05	Peak	111	1.67	RB:1MHz;VB:3MHz;Detector:PK
5460	39.36	H	54	-14.64	Avg	111	1.67	RB:1MHz;VB:10Hz;Detector:PK



Test #4 EUT on Channel140 5700MHz - 802.11a, Chain B

Antenna Port	Target (dBm)	Power Settings Measured (dBm)	Software Setting
Chain B	15.5	15.46	23

Fundamental Signal Field Strength

Frequency MHz	Level dBuV/m	Test Polar V/H	15.209/15.407		Detector PK/AV	Azimuth degrees	Height meters	Comments
			Limit	Margin				
5693.11	103.39	V	-	-	Peak	240	1.01	RB:1MHz;VB:3MHz;Detector:PK
5692.95	93.38	V	-	-	Avg	240	1.01	RB:1MHz;VB:10Hz;Detector:PK
5692.95	103.87	H	-	-	Peak	160	1.11	RB:1MHz;VB:3MHz;Detector:PK
5693.27	93.64	H	-	-	Avg	160	1.11	RB:1MHz;VB:10Hz;Detector:PK

Direct Measurement of Field Strength at the bandedge

Frequency MHz	Level dBuV/m	Test Polar V/H	15.209/15.407		Detector PK/AV	Azimuth degrees	Height meters	Comments
			Limit	Margin				
5725.01	61.99	V	68.3	-6.31	Peak	240	1.01	RB:1MHz;VB:3MHz;Detector:PK
5725	54.48	H	68.3	-13.82	Peak	160	1.11	RB:1MHz;VB:3MHz;Detector:PK



Date of Test:	2011/12/15
Test Engineer:	Denis Su

Test #1 EUT on Channel36 5180MHz- 802.11n 20MHz, Chain A

Antenna Port	Target (dBm)	Power Settings Measured (dBm)	Software Setting
Chain A	15	15.2	18.5

Fundamental Signal Field Strength

Frequency	Level	Test Polar	15.209/15.407		Detector	Azimuth	Height	Comments
MHz	dBuV/m	V/H	Limit	Margin	PK/AV	degrees	meters	
5172.47	102.28	V	-	-	Peak	114	1	RB:1MHz;VB:3MHz;Detector:PK
5173.27	92.43	V	-	-	Avg	114	1	RB:1MHz;VB:10Hz;Detector:PK
5173.75	101.58	H	-	-	Peak	242	1.44	RB:1MHz;VB:3MHz;Detector:PK
5174.07	91.4	H	-	-	Avg	242	1.44	RB:1MHz;VB:10Hz;Detector:PK

Direct Measurement of Field Strength at the bandedge

Frequency	Level	Test Polar	15.209/15.407		Detector	Azimuth	Height	Comments
MHz	dBuV/m	V/H	Limit	Margin	PK/AV	degrees	meters	
5149.36	58.59	V	74	-15.41	Peak	114	1	RB:1MHz;VB:3MHz;Detector:PK
5150	42.46	V	54	-11.54	Avg	114	1	RB:1MHz;VB:10Hz;Detector:PK
5148.56	58.22	H	74	-15.78	Peak	242	1.44	RB:1MHz;VB:3MHz;Detector:PK
5150	42.12	H	54	-11.88	Avg	242	1.44	RB:1MHz;VB:10Hz;Detector:PK



Test #2 EUT on Channel64 5320MHz- 802.11n 20MHz, Chain A

Antenna Port	Target (dBm)	Power Settings Measured (dBm)	Software Setting
Chain A	15.5	15.46	20

Fundamental Signal Field Strength

Frequency MHz	Level dBuV/m	Test Polar V/H	15.209/15.407		Detector PK/AV	Azimuth degrees	Height meters	Comments
			Limit	Margin				
5315.19	105.03	V	-	-	Peak	169	1.1	RB:1MHz;VB:3MHz;Detector:PK
5314.39	94.92	V	-	-	Avg	169	1.1	RB:1MHz;VB:10Hz;Detector:PK
5327.53	101.82	H	-	-	Peak	191	1.12	RB:1MHz;VB:3MHz;Detector:PK
5325.29	91.93	H	-	-	Avg	191	1.12	RB:1MHz;VB:10Hz;Detector:PK

Direct Measurement of Field Strength at the bandedge

Frequency MHz	Level dBuV/m	Test Polar V/H	15.209/15.407		Detector PK/AV	Azimuth degrees	Height meters	Comments
			Limit	Margin				
5350.16	56.54	V	74	-17.46	Peak	169	1.1	RB:1MHz;VB:3MHz;Detector:PK
5350	41.92	V	54	-12.08	Avg	169	1.1	RB:1MHz;VB:10Hz;Detector:PK
5350	56.22	H	74	-17.78	Peak	191	1.12	RB:1MHz;VB:3MHz;Detector:PK
5350	40.9	H	54	-13.1	Avg	191	1.12	RB:1MHz;VB:10Hz;Detector:PK



Test #3 EUT on Channel100 5500MHz - 802.11n 20MHz, Chain A

Antenna Port	Target (dBm)	Power Settings Measured (dBm)	Software Setting
Chain A	16	15.93	22

Fundamental Signal Field Strength

Frequency	Level	Test Polar	15.209/15.407		Detector	Azimuth	Height	Comments
MHz	dBuV/m	V/H	Limit	Margin	PK/AV	degrees	meters	
5495.19	100	V	-	-	Peak	345	1	RB:1MHz;VB:3MHz;Detector:PK
5494.71	89.76	V	-	-	Avg	345	1	RB:1MHz;VB:10Hz;Detector:PK
5501.76	101.83	H	-	-	Peak	85	1.64	RB:1MHz;VB:3MHz;Detector:PK
5505.29	92.06	H	-	-	Avg	85	1.64	RB:1MHz;VB:10Hz;Detector:PK

Direct Measurement of Field Strength at the bandedge

Frequency	Level	Test Polar	15.209/15.407		Detector	Azimuth	Height	Comments
MHz	dBuV/m	V/H	Limit	Margin	PK/AV	degrees	meters	
5459.36	51.08	V	74	-22.92	Peak	345	1	RB:1MHz;VB:3MHz;Detector:PK
5467.28	56.7	V	68.3	-11.6	Peak	345	1	RB:1MHz;VB:3MHz;Detector:PK
5460	39.06	V	54	-14.94	Avg	345	1	RB:1MHz;VB:10Hz;Detector:PK
5467.12	56.98	H	68.3	-11.32	Peak	85	1.64	RB:1MHz;VB:3MHz;Detector:PK
5459.68	53.12	H	74	-20.88	Peak	85	1.64	RB:1MHz;VB:3MHz;Detector:PK
5460	39.47	H	54	-14.53	Avg	85	1.64	RB:1MHz;VB:10Hz;Detector:PK



Test #4 EUT on Channel140 5700MHz - 802.11n 20MHz, Chain A

Antenna Port	Target (dBm)	Power Settings Measured (dBm)	Software Setting
Chain A	15.5	15.35	23.5

Fundamental Signal Field Strength

Frequency	Level	Test Polar	15.209/15.407		Detector	Azimuth	Height	Comments
MHz	dBuV/m	V/H	Limit	Margin	PK/AV	degrees	meters	
5695.19	100.17	V	-	-	Peak	248	1.32	RB:1MHz;VB:3MHz;Detector:PK
5696.8	89.45	V	-	-	Avg	248	1.32	RB:1MHz;VB:10Hz;Detector:PK
5695.03	99.97	H	-	-	Peak	285	1.33	RB:1MHz;VB:3MHz;Detector:PK
5694.71	89.7	H	-	-	Avg	285	1.33	RB:1MHz;VB:10Hz;Detector:PK

Direct Measurement of Field Strength at the bandedge

Frequency	Level	Test Polar	15.209/15.407		Detector	Azimuth	Height	Comments
MHz	dBuV/m	V/H	Limit	Margin	PK/AV	degrees	meters	
5725	61.43	V	68.3	-6.87	Peak	248	1.32	RB:1MHz;VB:3MHz;Detector:PK
5725	62.16	H	68.3	-6.14	Peak	285	1.33	RB:1MHz;VB:3MHz;Detector:PK



Date of Test:	2011/12/15
Test Engineer:	Denis Su

Test #1 EUT on Channel36 5180MHz - 802.11n 20MHz, Chain B

Antenna Port	Target (dBm)	Power Settings Measured (dBm)	Software Setting
Chain B	15	14.95	20

Fundamental Signal Field Strength

Frequency	Level	Test Polar	15.209/15.407		Detector	Azimuth	Height	Comments
			Limit	Margin				
MHz	dBuV/m	V/H			PK/AV	degrees	meters	
5187.53	101.64	V	-	-	Peak	187	1	RB:1MHz;VB:3MHz;Detector:PK
5185.29	91.49	V	-	-	Avg	187	1	RB:1MHz;VB:10Hz;Detector:PK
5172.95	102.2	H	-	-	Peak	108	1.32	RB:1MHz;VB:3MHz;Detector:PK
5185.29	92.09	H	-	-	Avg	108	1.32	RB:1MHz;VB:10Hz;Detector:PK

Direct Measurement of Field Strength at the bandedge

Frequency	Level	Test Polar	15.209/15.407		Detector	Azimuth	Height	Comments
			Limit	Margin				
MHz	dBuV/m	V/H			PK/AV	degrees	meters	
5148.56	59.93	V	74	-14.07	Peak	187	1	RB:1MHz;VB:3MHz;Detector:PK
5150	43.84	V	54	-10.16	Avg	187	1	RB:1MHz;VB:10Hz;Detector:PK
5150	60.05	H	74	-13.95	Peak	108	1.32	RB:1MHz;VB:3MHz;Detector:PK
5150	44.46	H	54	-9.54	Avg	108	1.32	RB:1MHz;VB:10Hz;Detector:PK



Test #2 EUT on Channel64 5320MHz - 802.11n 20MHz, Chain B

Antenna Port	Target (dBm)	Power Settings Measured (dBm)	Software Setting
Chain B	15.5	15.59	21

Fundamental Signal Field Strength

Frequency MHz	Level dBuV/m	Test Polar V/H	15.209/15.407		Detector PK/AV	Azimuth degrees	Height meters	Comments
			Limit	Margin				
5312.31	101.02	V	-	-	Peak	249	1	RB:1MHz;VB:3MHz;Detector:PK
5325.61	90.82	V	-	-	Avg	249	1	RB:1MHz;VB:10Hz;Detector:PK
5315.35	103.81	H	-	-	Peak	108	1.26	RB:1MHz;VB:3MHz;Detector:PK
5314.23	93.63	H	-	-	Avg	108	1.26	RB:1MHz;VB:10Hz;Detector:PK

Direct Measurement of Field Strength at the bandedge

Frequency MHz	Level dBuV/m	Test Polar V/H	15.209/15.407		Detector PK/AV	Azimuth degrees	Height meters	Comments
			Limit	Margin				
5350	54.3	V	74	-19.7	Peak	249	1	RB:1MHz;VB:3MHz;Detector:PK
5350	40.93	V	54	-13.07	Avg	249	1	RB:1MHz;VB:10Hz;Detector:PK
5350.96	58.08	H	74	-15.92	Peak	108	1.26	RB:1MHz;VB:3MHz;Detector:PK
5350	42.56	H	54	-11.44	Avg	108	1.26	RB:1MHz;VB:10Hz;Detector:PK



Test #3 EUT on Channel100 5500MHz - 802.11n 20MHz, Chain B

Antenna Port	Target (dBm)	Power Settings Measured (dBm)	Software Setting
Chain B	16	15.89	22.5

Fundamental Signal Field Strength

Frequency MHz	Level dBuV/m	Test Polar V/H	15.209/15.407		Detector PK/AV	Azimuth degrees	Height meters	Comments
			Limit	Margin				
5495.19	103.16	V	-	-	Peak	199	1	RB:1MHz;VB:3MHz;Detector:PK
5494.71	92.91	V	-	-	Avg	199	1	RB:1MHz;VB:10Hz;Detector:PK
5495.19	105.15	H	-	-	Peak	111	1.69	RB:1MHz;VB:3MHz;Detector:PK
5494.39	94.86	H	-	-	Avg	111	1.69	RB:1MHz;VB:10Hz;Detector:PK

Direct Measurement of Field Strength at the bandedge

Frequency MHz	Level dBuV/m	Test Polar V/H	15.209/15.407		Detector PK/AV	Azimuth degrees	Height meters	Comments
			Limit	Margin				
5495.2	52.15	V	74	-21.85	Peak	199	1	RB:1MHz;VB:3MHz;Detector:PK
5468.72	58.82	V	68.3	-9.48	Peak	199	1	RB:1MHz;VB:3MHz;Detector:PK
5460	39.15	V	54	-14.85	Avg	199	1	RB:1MHz;VB:10Hz;Detector:PK
5459.36	53.87	H	74	-20.13	Peak	111	1.69	RB:1MHz;VB:3MHz;Detector:PK
5465.51	61.26	H	68.3	-7.04	Peak	111	1.69	RB:1MHz;VB:3MHz;Detector:PK
5460	39.56	H	54	-14.44	Avg	111	1.69	RB:1MHz;VB:10Hz;Detector:PK



Test #4 EUT on Channel140 5700MHz - 802.11n 20MHz, Chain B

Antenna Port	Target (dBm)	Power Settings Measured (dBm)	Software Setting
Chain B	15.5	15.62	23.5

Fundamental Signal Field Strength

Frequency MHz	Level dBuV/m	Test Polar V/H	15.209/15.407		Detector PK/AV	Azimuth degrees	Height meters	Comments
			Limit	Margin				
5693.11	102.82	V	-	-	Peak	241	1.01	RB:1MHz;VB:3MHz;Detector:PK
5694.23	92.585	V	-	-	Avg	241	1.01	RB:1MHz;VB:10Hz;Detector:PK
5695.03	103.16	H	-	-	Peak	111	1.61	RB:1MHz;VB:3MHz;Detector:PK
5694.39	93.11	H	-	-	Avg	111	1.61	RB:1MHz;VB:10Hz;Detector:PK

Direct Measurement of Field Strength at the bandedge

Frequency MHz	Level dBuV/m	Test Polar V/H	15.209/15.407		Detector PK/AV	Azimuth degrees	Height meters	Comments
			Limit	Margin				
5725.16	62.4952	V	68.3	-5.8	Peak	241	1.01	RB:1MHz;VB:3MHz;Detector:PK
5725	61.6645	H	68.3	-6.6	Peak	111	1.61	RB:1MHz;VB:3MHz;Detector:PK



Date of Test:	Dec. 15, 2011
Test Engineer:	Denis Su

Test #1 EUT on Channel38 5190MHz- 802.11n 40MHz, Chain A

Antenna Port	Target (dBm)	Power Settings Measured (dBm)	Software Setting
Chain A	10.5	10.4	14

Fundamental Signal Field Strength

Frequency	Level	Test Polar	15.209/15.407		Detector	Azimuth	Height	Comments
			Limit	Margin				
MHz	dBuV/m	V/H			PK/AV	degrees	meters	
5198.01	95.32	V	-	-	Peak	114	1	RB:1MHz;VB:3MHz;Detector:PK
5197.69	85.18	V	-	-	Avg	114	1	RB:1MHz;VB:10Hz;Detector:PK
5182.63	94.75	H	-	-	Peak	244	1.43	RB:1MHz;VB:3MHz;Detector:PK
5202.5	83.83	H	-	-	Avg	244	1.43	RB:1MHz;VB:10Hz;Detector:PK

Direct Measurement of Field Strength at the bandedge

Frequency	Level	Test Polar	15.209/15.407		Detector	Azimuth	Height	Comments
			Limit	Margin				
MHz	dBuV/m	V/H			PK/AV	degrees	meters	
5148.08	55.23	V	74	-18.77	Peak	114	1	RB:1MHz;VB:3MHz;Detector:PK
5150	41.81	V	54	-12.19	Avg	114	1	RB:1MHz;VB:10Hz;Detector:PK
5148.72	54.68	H	74	-19.32	Peak	244	1.43	RB:1MHz;VB:3MHz;Detector:PK
5150	41.51	H	54	-12.49	Avg	244	1.43	RB:1MHz;VB:10Hz;Detector:PK



Test #2 EUT on Channel62 5310MHz- 802.11n 40MHz, Chain A

Antenna Port	Target (dBm)	Power Settings Measured (dBm)	Software Setting
Chain A	11	11.06	9.5

Fundamental Signal Field Strength

Frequency MHz	Level dBuV/m	Test Polar V/H	15.209/15.407		Detector PK/AV	Azimuth degrees	Height meters	Comments
			Limit	Margin				
5307.76	97.11	V	-	-	Peak	169	1.09	RB:1MHz;VB:3MHz;Detector:PK
5312.89	86.87	V	-	-	Avg	169	1.09	RB:1MHz;VB:10Hz;Detector:PK
5307.76	97.2	H	-	-	Peak	193	1.26	RB:1MHz;VB:3MHz;Detector:PK
5307.44	85.97	H	-	-	Avg	193	1.26	RB:1MHz;VB:10Hz;Detector:PK

Direct Measurement of Field Strength at the bandedge

Frequency MHz	Level dBuV/m	Test Polar V/H	15.209/15.407		Detector PK/AV	Azimuth degrees	Height meters	Comments
			Limit	Margin				
5350.96	56.47	V	74	-17.53	Peak	169	1.09	RB:1MHz;VB:3MHz;Detector:PK
5350	43.02	V	54	-10.98	Avg	169	1.09	RB:1MHz;VB:10Hz;Detector:PK
5351.28	55.92	H	74	-18.08	Peak	193	1.26	RB:1MHz;VB:3MHz;Detector:PK
5350	42.57	H	54	-11.43	Avg	193	1.26	RB:1MHz;VB:10Hz;Detector:PK



Test #3 EUT on Channel102 5510MHz- 802.11n 40MHz, Chain A

Antenna Port	Target (dBm)	Power Settings Measured (dBm)	Software Setting
Chain A	13.5	13.43	20

Fundamental Signal Field Strength

Frequency MHz	Level dBuV/m	Test Polar V/H	15.209/15.407		Detector PK/AV	Azimuth degrees	Height meters	Comments
			Limit	Margin				
5513.53	100.54	V	-	-	Peak	112	1.31	RB:1MHz;VB:3MHz;Detector:PK
5512.56	90.06	V	-	-	Avg	112	1.31	RB:1MHz;VB:10Hz;Detector:PK
5497.18	98.8	H	-	-	Peak	247	1.47	RB:1MHz;VB:3MHz;Detector:PK
5497.5	88.56	H	-	-	Avg	247	1.47	RB:1MHz;VB:10Hz;Detector:PK

Direct Measurement of Field Strength at the bandedge

Frequency MHz	Level dBuV/m	Test Polar V/H	15.209/15.407		Detector PK/AV	Azimuth degrees	Height meters	Comments
			Limit	Margin				
5460	56.95	V	74	-17.05	Peak	112	1.31	RB:1MHz;VB:3MHz;Detector:PK
5470	65.97	V	68.3	-2.33	Peak	112	1.31	RB:1MHz;VB:3MHz;Detector:PK
5460	42.94	V	54	-11.06	Avg	112	1.31	RB:1MHz;VB:10Hz;Detector:PK
5459.04	54.26	H	74	-19.74	Peak	247	1.47	RB:1MHz;VB:3MHz;Detector:PK
5470	61.43	H	68.3	-6.87	Peak	247	1.47	RB:1MHz;VB:3MHz;Detector:PK
5460	40.63	H	54	-13.37	Avg	247	1.47	RB:1MHz;VB:10Hz;Detector:PK



Test #4 EUT on Channel134 5670MHz - 802.11n 40MHz, Chain A

Antenna Port	Target (dBm)	Power Settings Measured (dBm)	Software Setting
Chain A	15.5	15.34	24

Fundamental Signal Field Strength

Frequency MHz	Level dBuV/m	Test Polar V/H	15.209/15.407		Detector PK/AV	Azimuth degrees	Height meters	Comments
			Limit	Margin				
5667.44	97.92	V	-	-	Peak	291	1	RB:1MHz;VB:3MHz;Detector:PK
5667.76	86.79	V	-	-	Avg	291	1	RB:1MHz;VB:10Hz;Detector:PK
5662.31	97.88	H	-	-	Peak	292	1	RB:1MHz;VB:3MHz;Detector:PK
5667.44	86.8	H	-	-	Avg	292	1	RB:1MHz;VB:10Hz;Detector:PK

Direct Measurement of Field Strength at the bandedge

Frequency MHz	Level dBuV/m	Test Polar V/H	15.209/15.407		Detector PK/AV	Azimuth degrees	Height meters	Comments
			Limit	Margin				
5725.32	50.98	V	68.3	-17.32	Peak	291	1	RB:1MHz;VB:3MHz;Detector:PK
5725.64	51.27	H	68.3	-17.03	Peak	292	1	RB:1MHz;VB:3MHz;Detector:PK



Date of Test:	Dec. 15, 2011
Test Engineer:	Denis Su

Test #1 EUT on Channel38 5190MHz- 802.11n 40MHz, Chain B

Antenna Port	Target (dBm)	Power Settings Measured (dBm)	Software Setting
Chain B	10.5	10.38	15.5

Fundamental Signal Field Strength

Frequency	Level	Test Polar	15.209/15.407		Detector	Azimuth	Height	Comments
			Limit	Margin				
MHz	dBuV/m	V/H			PK/AV	degrees	meters	
5188.08	94.84	V	-	-	Peak	186	1	RB:1MHz;VB:3MHz;Detector:PK
5192.56	84.21	V	-	-	Avg	186	1	RB:1MHz;VB:10Hz;Detector:PK
5193.53	95.55	H	-	-	Peak	108	1.32	RB:1MHz;VB:3MHz;Detector:PK
5192.56	85.16	H	-	-	Avg	108	1.32	RB:1MHz;VB:10Hz;Detector:PK

Direct Measurement of Field Strength at the bandedge

Frequency	Level	Test Polar	15.209/15.407		Detector	Azimuth	Height	Comments
			Limit	Margin				
MHz	dBuV/m	V/H			PK/AV	degrees	meters	
5150	57.58	V	74	-16.42	Peak	186	1	RB:1MHz;VB:3MHz;Detector:PK
5150	43.77	V	54	-10.23	Avg	186	1	RB:1MHz;VB:10Hz;Detector:PK
5150	58.17	H	74	-15.83	Peak	108	1.32	RB:1MHz;VB:3MHz;Detector:PK
5150	44.1	H	54	-9.9	Avg	108	1.32	RB:1MHz;VB:10Hz;Detector:PK



Test #2 EUT on Channel62 5310MHz- 802.11n 40MHz, Chain B

Antenna Port	Target (dBm)	Power Settings Measured (dBm)	Software Setting
Chain B	11	11.1	9.5

Fundamental Signal Field Strength

Frequency MHz	Level dBuV/m	Test Polar V/H	15.209/15.407		Detector PK/AV	Azimuth degrees	Height meters	Comments
			Limit	Margin				
5297.5	94.97	V	-	-	Peak	225	1	RB:1MHz;VB:3MHz;Detector:PK
5297.5	84.31	V	-	-	Avg	225	1	RB:1MHz;VB:10Hz;Detector:PK
5303.59	97.67	H	-	-	Peak	112	1.38	RB:1MHz;VB:3MHz;Detector:PK
5297.82	86.97	H	-	-	Avg	112	1.38	RB:1MHz;VB:10Hz;Detector:PK

Direct Measurement of Field Strength at the bandedge

Frequency MHz	Level dBuV/m	Test Polar V/H	15.209/15.407		Detector PK/AV	Azimuth degrees	Height meters	Comments
			Limit	Margin				
5350.96	55.72	V	74	-18.28	Peak	225	1	RB:1MHz;VB:3MHz;Detector:PK
5350	41.95	V	54	-12.05	Avg	225	1	RB:1MHz;VB:10Hz;Detector:PK
5350.96	57.97	H	74	-16.03	Peak	112	1.38	RB:1MHz;VB:3MHz;Detector:PK
5350	44.08	H	54	-9.92	Avg	112	1.38	RB:1MHz;VB:10Hz;Detector:PK



Test #3 EUT on Channel102 5510MHz- 802.11n 40MHz, Chain B

Antenna Port	Target (dBm)	Power Settings Measured (dBm)	Software Setting
Chain B	13.5	13.47	20

Fundamental Signal Field Strength

Frequency MHz	Level dBuV/m	Test Polar V/H	15.209/15.407		Detector PK/AV	Azimuth degrees	Height meters	Comments
			Limit	Margin				
5498.46	100.69	V	-	-	Peak	187	1.2	RB:1MHz;VB:3MHz;Detector:PK
5497.82	90.02	V	-	-	Avg	187	1.2	RB:1MHz;VB:10Hz;Detector:PK
5507.12	98.178	H	-	-	Peak	109	1.64	RB:1MHz;VB:3MHz;Detector:PK
5507.44	87.9	H	-	-	Avg	109	1.64	RB:1MHz;VB:10Hz;Detector:PK

Direct Measurement of Field Strength at the bandedge

Frequency MHz	Level dBuV/m	Test Polar V/H	15.209/15.407		Detector PK/AV	Azimuth degrees	Height meters	Comments
			Limit	Margin				
5459.68	56.07	V	74	-17.93	Peak	187	1.2	RB:1MHz;VB:3MHz;Detector:PK
5469.68	64.51	V	68.3	-3.79	Peak	187	1.2	RB:1MHz;VB:3MHz;Detector:PK
5460	41.86	V	54	-12.14	Avg	187	1.2	RB:1MHz;VB:10Hz;Detector:PK
5459.68	53.012	H	74	-20.988	Peak	109	1.64	RB:1MHz;VB:3MHz;Detector:PK
5470	62.13	H	68.3	-6.17	Peak	109	1.64	RB:1MHz;VB:3MHz;Detector:PK
5460	40.6	H	54	-13.4	Avg	109	1.64	RB:1MHz;VB:10Hz;Detector:PK



Test #4 EUT on Channel134 5670MHz- 802.11n 40MHz, Chain B

Antenna Port	Target (dBm)	Power Settings Measured (dBm)	Software Setting
Chain B	15.5	15.52	25

Fundamental Signal Field Strength

Frequency MHz	Level dBuV/m	Test Polar V/H	15.209/15.407		Detector PK/AV	Azimuth degrees	Height meters	Comments
			Limit	Margin				
5662.31	101.09	V	-	-	Peak	244	1	RB:1MHz;VB:3MHz;Detector:PK
5667.44	89.48	V	-	-	Avg	244	1	RB:1MHz;VB:10Hz;Detector:PK
5682.5	100.58	H	-	-	Peak	109	1.69	RB:1MHz;VB:3MHz;Detector:PK
5682.5	89.97	H	-	-	Avg	109	1.69	RB:1MHz;VB:10Hz;Detector:PK

Direct Measurement of Field Strength at the bandedge

Frequency MHz	Level dBuV/m	Test Polar V/H	15.209/15.407		Detector PK/AV	Azimuth degrees	Height meters	Comments
			Limit	Margin				
5725	57.05	V	68.3	-11.25	Peak	244	1	RB:1MHz;VB:3MHz;Detector:PK
5725.64	56.66	H	68.3	-11.64	Peak	109	1.69	RB:1MHz;VB:3MHz;Detector:PK



Date of Test:	Dec. 15, 2011
Test Engineer:	Denis Su

Test #1 EUT on Channel36 5180MHz - 802.11n 20MHz, ChainA+B

Chain	Target (dBm)			Power Settings Measured (dBm)			Software Setting	
	A	B	Total	A	B	Total		
	13	13	16.01	13.01	13.01	16.02	18.5	20.5

Fundamental Signal Field Strength

Frequency MHz	Level dBuV/m	Test Polar V/H	15.209/15.407		Detector PK/AV	Azimuth degrees	Height meters	Comments
			Limit	Margin				
5174.23	101.58	V	-	-	Peak	113	1	RB:1MHz;VB:3MHz;Detector:PK
5173.27	89.27	V	-	-	Avg	113	1	RB:1MHz;VB:10Hz;Detector:PK
5186.89	100.59	H	-	-	Peak	249	1.47	RB:1MHz;VB:3MHz;Detector:PK
5187.05	88.53	H	-	-	Avg	249	1.47	RB:1MHz;VB:10Hz;Detector:PK

Direct Measurement of Field Strength at the bandedge

Frequency MHz	Level dBuV/m	Test Polar V/H	15.209/15.407		Detector PK/AV	Azimuth degrees	Height meters	Comments
			Limit	Margin				
5149.84	53.7	V	74	-20.3	Peak	113	1	RB:1MHz;VB:3MHz;Detector:PK
5150	40.31	V	54	-13.69	Avg	113	1	RB:1MHz;VB:10Hz;Detector:PK
5149.84	53.86	H	74	-20.14	Peak	249	1.47	RB:1MHz;VB:3MHz;Detector:PK
5150	40.2	H	54	-13.8	Avg	249	1.47	RB:1MHz;VB:10Hz;Detector:PK



Test #2 EUT on Channel64 5320MHz - 802.11n 20MHz, ChainA+B

Chain	Target (dBm)			Power Settings Measured (dBm)			Software Setting	
	A	B	Total	A	B	Total		
	13	13	16.01	13.1	13.12	16.12	21	21

Fundamental Signal Field Strength

Frequency MHz	Level dBuV/m	Test Polar V/H	15.209/15.407		Detector PK/AV	Azimuth degrees	Height meters	Comments
			Limit	Margin				
5317.28	105.75	V	-	-	Peak	172	1.22	RB:1MHz;VB:3MHz;Detector:PK
5314.71	92.87	V	-	-	Avg	172	1.22	RB:1MHz;VB:10Hz;Detector:PK
5315.35	103.81	H	-	-	Peak	111	1.33	RB:1MHz;VB:3MHz;Detector:PK
5313.75	90.66	H	-	-	Avg	111	1.33	RB:1MHz;VB:10Hz;Detector:PK

Direct Measurement of Field Strength at the bandedge

Frequency MHz	Level dBuV/m	Test Polar V/H	15.209/15.407		Detector PK/AV	Azimuth degrees	Height meters	Comments
			Limit	Margin				
5350	53.57	V	74	-20.43	Peak	172	1.22	RB:1MHz;VB:3MHz;Detector:PK
5350	40.84	V	54	-13.16	Avg	172	1.22	RB:1MHz;VB:10Hz;Detector:PK
5350.32	54.32	H	74	-19.68	Peak	111	1.33	RB:1MHz;VB:3MHz;Detector:PK
5350	41.05	H	54	-12.95	Avg	111	1.33	RB:1MHz;VB:10Hz;Detector:PK



Test #3 EUT on Channel100 5500MHz - 802.11n 20MHz, ChainA+B

Chain	Target (dBm)			Power Settings Measured (dBm)			Software Setting	
	A	B	Total	A	B	Total		
	13	13	16.01	13.2	13.2	16.21	22.5	22

Fundamental Signal Field Strength

Frequency	Level	Test Polar	15.209/15.407		Detector	Azimuth	Height	Comments
			Limit	Margin				
MHz	dBuV/m	V/H			PK/AV	degrees	meters	
5504.81	103.35	V	-	-	Peak	199	1.29	RB:1MHz;VB:3MHz;Detector:PK
5506.25	90.44	V	-	-	Avg	199	1.29	RB:1MHz;VB:10Hz;Detector:PK
5495.03	100.18	H	-	-	Peak	348	1	RB:1MHz;VB:3MHz;Detector:PK
5495.03	87.39	H	-	-	Avg	348	1	RB:1MHz;VB:10Hz;Detector:PK

Direct Measurement of Field Strength at the bandedge

Frequency	Level	Test Polar	15.209/15.407		Detector	Azimuth	Height	Comments
			Limit	Margin				
MHz	dBuV/m	V/H			PK/AV	degrees	meters	
5460	50.91	V	74	-23.09	Peak	199	1.29	RB:1MHz;VB:3MHz;Detector:PK
5469.84	54.03	V	68.3	-14.27	Peak	199	1.29	RB:1MHz;VB:3MHz;Detector:PK
5460	38.97	V	54	-15.03	Avg	199	1.29	RB:1MHz;VB:10Hz;Detector:PK
5459.36	50.99	H	74	-23.01	Peak	348	1	RB:1MHz;VB:3MHz;Detector:PK
5468.88	52.15	H	68.3	-16.15	Peak	348	1	RB:1MHz;VB:3MHz;Detector:PK
5460	38.69	H	54	-15.31	Avg	348	1	RB:1MHz;VB:10Hz;Detector:PK



Test #4 EUT on Channel140 5700MHz - 802.11n 20MHz, ChainA+B

Chain	Target (dBm)			Power Settings Measured (dBm)			Software Setting	
	A	B	Total	A	B	Total		
	13.5	13.5	16.51	13.55	13.58	16.58	25.5	25

Fundamental Signal Field Strength

Frequency MHz	Level dBuV/m	Test Polar V/H	15.209/15.407		Detector PK/AV	Azimuth degrees	Height meters	Comments
			Limit	Margin				
5696.96	104.2	V	-	-	Peak	173	1	RB:1MHz;VB:3MHz;Detector:PK
5694.07	91.04	V	-	-	Avg	173	1	RB:1MHz;VB:10Hz;Detector:PK
5698.56	101.37	H	-	-	Peak	174	1.02	RB:1MHz;VB:3MHz;Detector:PK
5698.72	88.72	H	-	-	Avg	174	1.02	RB:1MHz;VB:10Hz;Detector:PK

Direct Measurement of Field Strength at the bandedge

Frequency MHz	Level dBuV/m	Test Polar V/H	15.209/15.407		Detector PK/AV	Azimuth degrees	Height meters	Comments
			Limit	Margin				
5725	57.99	V	68.3	-10.31	Peak	173	1	RB:1MHz;VB:3MHz;Detector:PK
5725	56.5	H	68.3	-11.8	Peak	174	1.02	RB:1MHz;VB:3MHz;Detector:PK



Date of Test:	Dec. 15, 2011
Test Engineer:	Denis Su

Test #1 EUT on Channel38 5190MHz- 802.11n 40MHz, ChainA+B

Chain	Target (dBm)			Power Settings Measured (dBm)			Software Setting	
	A	B	Total	A	B	Total		
	9	9	12.01	9.13	9.2	12.18	17.5	18

Fundamental Signal Field Strength

Frequency MHz	Level dBuV/m	Test Polar V/H	15.209/15.407		Detector PK/AV	Azimuth degrees	Height meters	Comments
			Limit	Margin				
5198.01	99.48	V	-	-	Peak	114	1	RB:1MHz;VB:3MHz;Detector:PK
5192.56	85.89	V	-	-	Avg	114	1	RB:1MHz;VB:10Hz;Detector:PK
5197.69	96.23	H	-	-	Peak	249	1.45	RB:1MHz;VB:3MHz;Detector:PK
5187.44	83.09	H	-	-	Avg	249	1.45	RB:1MHz;VB:10Hz;Detector:PK

Direct Measurement of Field Strength at the bandedge

Frequency MHz	Level dBuV/m	Test Polar V/H	15.209/15.407		Detector PK/AV	Azimuth degrees	Height meters	Comments
			Limit	Margin				
5150	57.94	V	74	-16.06	Peak	114	1	RB:1MHz;VB:3MHz;Detector:PK
5150	43.47	V	54	-10.53	Avg	114	1	RB:1MHz;VB:10Hz;Detector:PK
5149.68	58.73	H	74	-15.27	Peak	249	1.45	RB:1MHz;VB:3MHz;Detector:PK
5150	43.36	H	54	-10.64	Avg	249	1.45	RB:1MHz;VB:10Hz;Detector:PK



Test #2 EUT on Channel62 5310MHz - 802.11n 40MHz, ChainA+B

Chain	Target (dBm)			Power Settings Measured (dBm)			Software Setting	
	A	B	Total	A	B	Total		
	9.5	9.5	12.51	9.44	9.61	12.54	18.5	18.5

Fundamental Signal Field Strength

Frequency MHz	Level dBuV/m	Test Polar V/H	15.209/15.407		Detector PK/AV	Azimuth degrees	Height meters	Comments
			Limit	Margin				
5318.01	99.3	V	-	-	Peak	172	1.21	RB:1MHz;VB:3MHz;Detector:PK
5312.56	86.09	V	-	-	Avg	172	1.21	RB:1MHz;VB:10Hz;Detector:PK
5304.55	98.29	H	-	-	Peak	112	1.34	RB:1MHz;VB:3MHz;Detector:PK
5298.78	85.13	H	-	-	Avg	112	1.34	RB:1MHz;VB:10Hz;Detector:PK

Direct Measurement of Field Strength at the bandedge

Frequency MHz	Level dBuV/m	Test Polar V/H	15.209/15.407		Detector PK/AV	Azimuth degrees	Height meters	Comments
			Limit	Margin				
5350	56.81	V	74	-17.19	Peak	172	1.21	RB:1MHz;VB:3MHz;Detector:PK
5350	42.82	V	54	-11.18	Avg	172	1.21	RB:1MHz;VB:10Hz;Detector:PK
5350.32	55.18	H	74	-18.82	Peak	112	1.34	RB:1MHz;VB:3MHz;Detector:PK
5350	42.57	H	54	-11.43	Avg	112	1.34	RB:1MHz;VB:10Hz;Detector:PK



Test #3 EUT on Channel102 5510MHz- 802.11n 40MHz, ChainA+B

Chain	Target (dBm)			Power Settings Measured (dBm)			Software Setting	
	A	B	Total	A	B	Total		
	12.5	12.5	15.51	12.46	12.4	15.44	23	22.5

Fundamental Signal Field Strength

Frequency	Level	Test Polar	15.209/15.407		Detector	Azimuth	Height	Comments
			Limit	Margin				
MHz	dBuV/m	V/H			PK/AV	degrees	meters	
5505.51	99.06	V	-	-	Peak	205	1	RB:1MHz;VB:3MHz;Detector:PK
5505.83	85.08	V	-	-	Avg	205	1	RB:1MHz;VB:10Hz;Detector:PK
5497.5	96.15	H	-	-	Peak	346	1	RB:1MHz;VB:3MHz;Detector:PK
5498.46	83.61	H	-	-	Avg	346	1	RB:1MHz;VB:10Hz;Detector:PK

Direct Measurement of Field Strength at the bandedge

Frequency	Level	Test Polar	15.209/15.407		Detector	Azimuth	Height	Comments
			Limit	Margin				
MHz	dBuV/m	V/H			PK/AV	degrees	meters	
5460	53.89	V	74	-20.11	Peak	205	1	RB:1MHz;VB:3MHz;Detector:PK
5467.76	62.1	V	68.3	-6.2	Peak	205	1	RB:1MHz;VB:3MHz;Detector:PK
5460	41.08	V	54	-12.92	Avg	205	1	RB:1MHz;VB:10Hz;Detector:PK
5460	54.37	H	74	-19.63	Peak	346	1	RB:1MHz;VB:3MHz;Detector:PK
5469.68	60.87	H	68.3	-7.43	Peak	346	1	RB:1MHz;VB:3MHz;Detector:PK
5460	40.42	H	54	-13.58	Avg	346	1	RB:1MHz;VB:10Hz;Detector:PK



Test #4 EUT on Channel137 5670MHz - 802.11n 40MHz, ChainA+B

Chain	Target (dBm)			Power Settings Measured (dBm)			Software Setting	
	A	B	Total	A	B	Total		
	13	13	16.01	12.92	13.13	16.04	26	25.5

Fundamental Signal Field Strength

Frequency MHz	Level dBuV/m	Test Polar V/H	15.209/15.407		Detector PK/AV	Azimuth degrees	Height meters	Comments
			Limit	Margin				
5666.47	101.99	V	-	-	Peak	169	1	RB:1MHz;VB:3MHz;Detector:PK
5667.12	88.64	V	-	-	Avg	169	1	RB:1MHz;VB:10Hz;Detector:PK
5675.77	101.17	H	-	-	Peak	111	1.68	RB:1MHz;VB:3MHz;Detector:PK
5667.76	87.42	H	-	-	Avg	111	1.68	RB:1MHz;VB:10Hz;Detector:PK

Direct Measurement of Field Strength at the bandedge

Frequency MHz	Level dBuV/m	Test Polar V/H	15.209/15.407		Detector PK/AV	Azimuth degrees	Height meters	Comments
			Limit	Margin				
5725.32	52.48	V	68.3	-15.82	Peak	169	1	RB:1MHz;VB:3MHz;Detector:PK
5725.64	52.94	H	68.3	-15.36	Peak	111	1.68	RB:1MHz;VB:3MHz;Detector:PK

4.3. 99% Occupied Bandwidth Measurement

4.3.1. Summary of Test Results

MAC Address: 00:15:00:85:80:1C DRTU Tool Version: 1.5.2-0308 Driver version: 14.0.4.115

Pwr setting	EIRP Pwr (dBm)	Test Performed	Limit	Pass / Fail	Result (MHz)
-	19.87	802.11a 26dB Bandwidth (5150-5250MHz Band)	15.407	Pass	23.84
-	19.87	802.11a 99% Bandwidth (5150-5250MHz Band)	RSS 210	N/A	16.96
-	19.87	802.11n 20MHz 26dB Bandwidth (5150-5250MHz Band)	15.407	Pass	28.16
-	19.87	802.11n 20MHz 99% Bandwidth (5150-5250MHz Band)	RSS 210	N/A	18.08
-	19.87	802.11n 40MHz 26dB Bandwidth (5150-5250MHz Band)	15.407	Pass	42.24
-	19.87	802.11n 40MHz 99% Bandwidth (5150-5250MHz Band)	RSS 210	N/A	36.16
-	19.75	802.11a 26dB Bandwidth (5250-5350MHz Band)	15.407	Pass	25.12
-	19.75	802.11a 99% Bandwidth (5250-5350MHz Band)	RSS 210	N/A	16.96
-	19.77	802.11n 20MHz 26dB Bandwidth (5250-5350MHz Band)	15.407	Pass	28.80
-	19.77	802.11n 20MHz 99% Bandwidth (5250-5350MHz Band)	RSS 210	N/A	18.24
-	19.75	802.11n 40MHz 26dB Bandwidth (5250-5350MHz Band)	15.407	Pass	47.36
-	19.75	802.11n 40MHz 99% Bandwidth (5250-5350MHz Band)	RSS 210	N/A	36.16
-	20.91	802.11a 26dB Bandwidth (5470-5725MHz Band)	15.407	Pass	34.08
-	20.91	802.11a 99% Bandwidth (5470-5725MHz Band)	RSS 210	N/A	17.60
-	20.88	802.11n 20MHz 26dB Bandwidth (5470-5725MHz Band)	15.407	Pass	39.04
-	20.88	802.11n 20MHz 99% Bandwidth (5470-5725MHz Band)	RSS 210	N/A	18.72
-	20.88	802.11n 40MHz 26dB Bandwidth (5470-5725MHz Band)	15.407	Pass	66.24
-	20.88	802.11n 40MHz 99% Bandwidth (5470-5725MHz Band)	RSS 210	N/A	36.48

4.3.2. Limit

No restriction limits. But resolution bandwidth within band edge measurement is 1% of the 99% occupied bandwidth.

4.3.3. Measuring Instruments and Setting

Please refer to section 5 of equipments list in this report. The following table is the setting of the spectrum analyzer.

Spectrum Parameters	Setting
Attenuation	Auto
Span Frequency	> 26dB Bandwidth
RB	300 kHz
VB	1000 kHz
Detector	Peak
Trace	Max Hold
Sweep Time	Auto

4.3.4. Test Procedures

1. The transmitter output (antenna port) was connected to the spectrum analyzer in peak hold mode.
2. The resolution bandwidth of 300 kHz and the video bandwidth of 1000 kHz were used.
3. Measured the spectrum width with power higher than 26dB below carrier.

4.3.5. Test Setup Layout

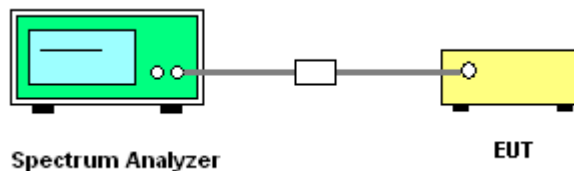

4.3.6. Test Deviation

There is no deviation with the original standard.

4.3.7. EUT Operation during Test

The EUT was programmed to be in continuously transmitting mode.

4.3.8. Test Result of 99% Occupied Bandwidth

Temperature	23°C	Humidity	61%
Test Engineer	Denis Su	Configurations	5150-5250MHz Band - Chain A
Test Date	Dec. 18, 2011~Dec. 23, 2011		

Single Chain Operation						
Antenna Gain	3.7	EIRP	97.05	mW	19.87	dBm
Frequency (MHz)	Software Setting	Bandwidth			Result	
		26dB	99% (Note)			
802.11a						
5180	17.5	20.64	16.96		Pass	
5200	18.5	23.84	16.96		Pass	
5240	18.5	23.52	16.96		Pass	
802.11n HT20						
5180	18.5	22.24	17.92		Pass	
5200	19.5	27.52	18.08		Pass	
5240	20	27.84	18.08		Pass	
802.11n HT40						
5190	14	39.2	35.84		Pass	
5230	20	42.24	36.16		Pass	
Note	99% Bandwidth measured in accordance with RSS GEN - RB > 1% of span and VB >= 3xRB					

Temperature	23°C	Humidity	61%
Test Engineer	Denis Su	Configurations	5150-5250MHz Band - Chain B
Test Date	Dec. 18, 2011~Dec. 23, 2011		

Single Chain Operation						
Antenna Gain	3.7	EIRP	97.27	mW	19.88	dBm
Frequency (MHz)	Software Setting	Bandwidth		Result		
		26dB	99% (Note)			
802.11a						
5180	20.5	26.08		16.96		Pass
5200	19.5	23.52		16.96		Pass
5240	19.5	23.52		16.96		Pass
802.11n HT20						
5180	20	25.92		17.92		Pass
5200	20	28.16		17.92		Pass
5240	20.5	26.72		17.92		Pass
802.11n HT40						
5190	15.5	39.04		36		Pass
5230	21	40.32		35.84		Pass
Note	99% Bandwidth measured in accordance with RSS GEN - RB > 1% of span and VB > =3xRB					



Temperature	23°C	Humidity	61%
Test Engineer	Denis Su	Configurations	5150-5250MHz Band – Chain A+B
Test Date	Dec. 18, 2011 ~ Dec. 23, 2011		

Single Chain Operation						
Antenna Gain	Chain A : 3.7 Chain B : 3.7		EIRP	97.62	mW	19.90 dBm
Frequency (MHz)	Software Setting		Bandwidth		Result	
	Chain A	Chain B	26dB	99% (Note)		
802.11n HT20						
5180	18.5	20.5	20.8	17.76	Pass	
5200	20.5	21	20.96	17.92	Pass	
5240	20.5	21	20.96	17.76	Pass	
802.11n HT40						
5190	17.5	18	38.4	36	Pass	
5230	20.5	21	38.4	35.84	Pass	
Note	99% Bandwidth measured in accordance with RSS GEN - RB > 1% of span and VB >= 3xRB					



Temperature	23°C	Humidity	61%
Test Engineer	Denis Su	Configurations	5250-5350MHz Band - Chain A
Test Date	Dec. 18, 2011 ~ Dec. 23, 2011		

Single Chain Operation						
Antenna Gain	3.7	EIRP	94.84	mW	19.77	dBm
Frequency (MHz)	Software Setting	Bandwidth		Result		
		26dB	99% (Note)			
802.11a						
5260	18.5	23.52		16.96		Pass
5300	19	24		16.96		Pass
5320	18.5	20.8		16.96		Pass
802.11n HT20						
5260	20	27.36		18.24		Pass
5300	20	28.8		18.08		Pass
5320	20	26.24		18.08		Pass
802.11n HT40						
5270	20.5	41.92		36.16		Pass
5310	15.5	39.2		36		Pass
Note	99% Bandwidth measured in accordance with RSS GEN - RB > 1% of span and VB > =3xRB					



Temperature	23°C	Humidity	61%
Test Engineer	Denis Su	Configurations	5250-5350MHz Band - Chain B
Test Date	Dec. 18, 2011~Dec. 23, 2011		

Single Chain Operation						
Antenna Gain	3.7	EIRP	94.41	mW	19.75	dBm
Frequency (MHz)	Software Setting	Bandwidth		Result		
		26dB	99% (Note)			
802.11a						
5260	19.5	23.84		16.96		Pass
5300	20	25.12		16.96		Pass
5320	20	23.2		16.96		Pass
802.11n HT20						
5260	20.5	27.68		18.08		Pass
5300	20.5	27.68		17.92		Pass
5320	21	28		18.08		Pass
802.11n HT40						
5270	21	47.36		36.16		Pass
5310	16.5	39.2		36		Pass
Note	99% Bandwidth measured in accordance with RSS GEN - RB > 1% of span and VB > =3xRB					



Temperature	23°C	Humidity	61%
Test Engineer	Denis Su	Configurations	5250-5350MHz Band – Chain A+B
Test Date	Dec. 18, 2011~Dec. 23, 2011		

Single Chain Operation						
Antenna Gain	Chain A : 3.7 Chain B : 3.7		EIRP	95.95	mW	19.82 dBm
Frequency (MHz)	Software Setting		Bandwidth		Result	
	Chain A	Chain B	26dB	99% (Note)		
802.11n HT20						
5260	20.5	21	21.12	17.92	Pass	
5300	20.5	21	20.8	17.92	Pass	
5320	21	21	20.48	17.76	Pass	
802.11n HT40						
5270	21	21.5	38.4	36.16	Pass	
5310	18.5	18.5	38.24	36	Pass	
Note	99% Bandwidth measured in accordance with RSS GEN - RB > 1% of span and VB >= 3xRB					



Temperature	23°C	Humidity	61%
Test Engineer	Denis Su	Configurations	5470-5725MHz Band - Chain A
Test Date	Dec. 18, 2011~Dec. 23, 2011		

Single Chain Operation						
Antenna Gain	4.8	EIRP	122.46	mW	20.88	dBm
Frequency (MHz)	Software Setting	Bandwidth		Result		
		26dB	99% (Note)			
802.11a						
5500	22	26.08	16.96	Pass		
5580	22	32.48	17.28	Pass		
5700	23.5	28.64	17.12	Pass		
802.11n HT20						
5500	22	28.48	18.08	Pass		
5580	23	39.04	18.72	Pass		
5700	23.5	31.52	18.24	Pass		
802.11n HT40						
5510	22	52.16	36.16	Pass		
5550	23	66.24	36.48	Pass		
5670	24	52.32	36.16	Pass		
Note	99% Bandwidth measured in accordance with RSS GEN - RB > 1% of span and VB > =3xRB					



Temperature	23°C	Humidity	61%
Test Engineer	Denis Su	Configurations	5470-5725MHz Band - Chain B
Test Date	Dec. 18, 2011 ~ Dec. 23, 2011		

Single Chain Operation						
Antenna Gain	4.8	EIRP	123.31	mW	20.91	dBm
Frequency (MHz)	Software Setting	Bandwidth		Result		
		26dB	99% (Note)			
802.11a						
5500	22.5	31.68		17.28		Pass
5580	22	28.8		17.28		Pass
5700	25	34.08		17.6		Pass
802.11n HT20						
5500	22.5	34.56		18.24		Pass
5580	23	32.96		18.4		Pass
5700	24	32.48		18.24		Pass
802.11n HT40						
5510	22.5	53.28		36.16		Pass
5550	24	61.44		36.48		Pass
5670	25	62.72		36.16		Pass
Note	99% Bandwidth measured in accordance with RSS GEN - RB > 1% of span and VB >= 3xRB					

Temperature	23°C	Humidity	61%
Test Engineer	Denis Su	Configurations	5470-5725MHz Band – Chain A+B
Test Date	Dec. 18, 2011 ~ Dec. 23, 2011		

Single Chain Operation							
Antenna Gain	Chain A : 4.8 Chain B : 4.8		EIRP	137.26	mW	21.38	dBm
Frequency (MHz)	Software Setting		Bandwidth		Result		
	Chain A	Chain B	26dB	99% (Note)			
802.11n HT20							
5500	22.5	22	20.96	17.92	Pass		
5580	23	23	21.28	17.92	Pass		
5700	25.5	25	20.8	17.92	Pass		
802.11n HT40							
5510	23	22.5	38.4	36	Pass		
5550	23	23.5	41.28	36.16	Pass		
5670	26	25.5	38.72	36.16	Pass		
Note	99% Bandwidth measured in accordance with RSS GEN - RB > 1% of span and VB > = 3xRB						

Note: All the test values were listed in the report.

For plots, only the channel with maximum results was shown.

26 dB Bandwidth Plot on Configuration IEEE 802.11n MCS0 20MHz / Chain B / 5200 MHz

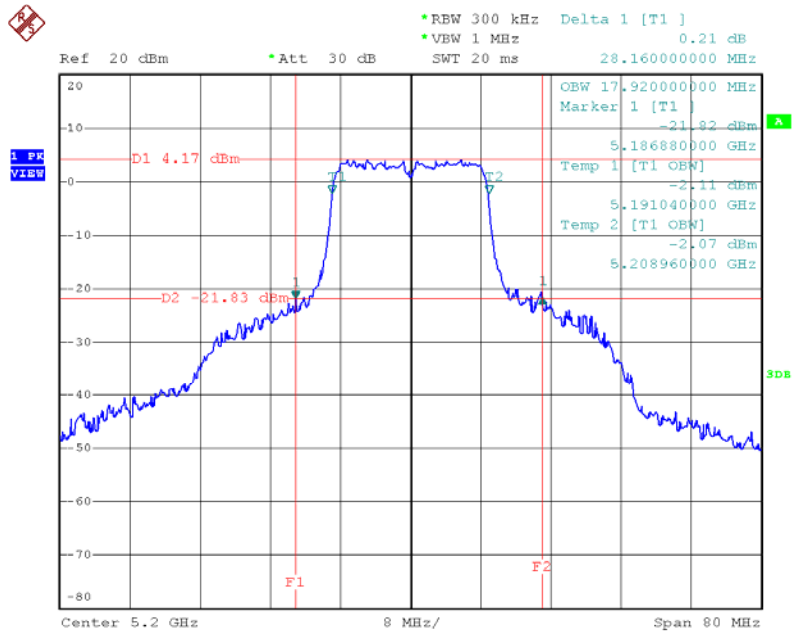

Date: 23.DEC.2011 08:04:34

26 dB Bandwidth Plot on Configuration IEEE 802.11n MCS0 20MHz / Chain A / 5300 MHz

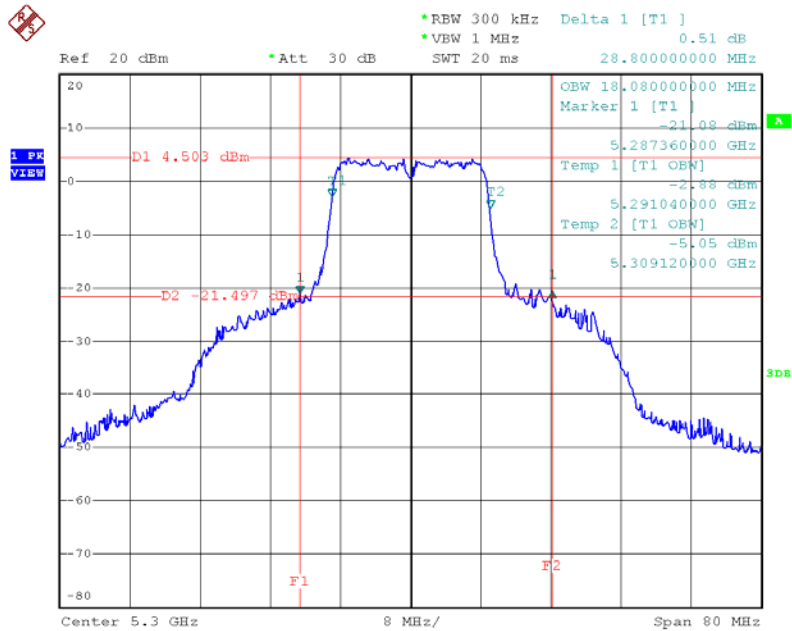

Date: 23.DEC.2011 07:56:55

26 dB Bandwidth Plot on Configuration IEEE 802.11n MCS0 20MHz / Chain A / 5580 MHz

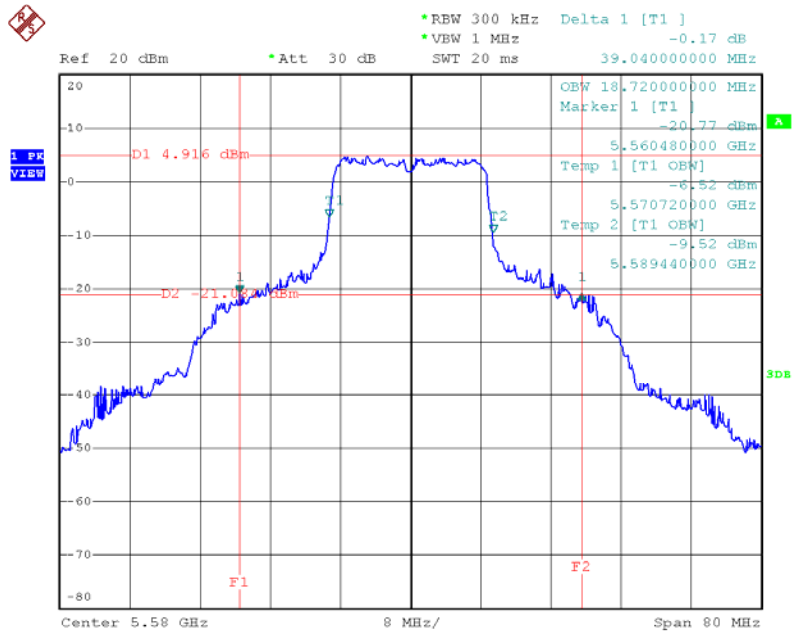

Date: 23.DEC.2011 07:56:08

26 dB Bandwidth Plot on Configuration IEEE 802.11n MCS0 40MHz / Chain A / 5230 MHz

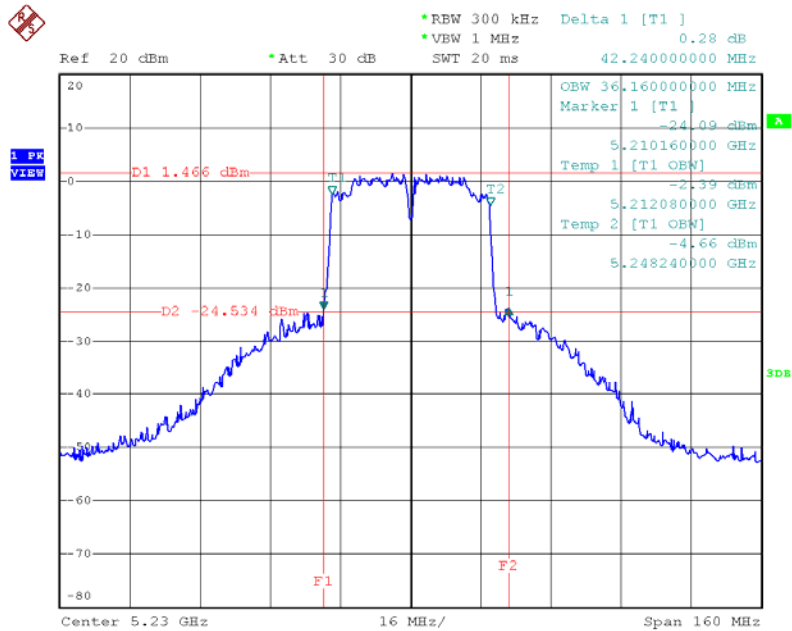

Date: 23.DEC.2011 07:59:19

26 dB Bandwidth Plot on Configuration IEEE 802.11n MCS0 40MHz / Chain B / 5270 MHz

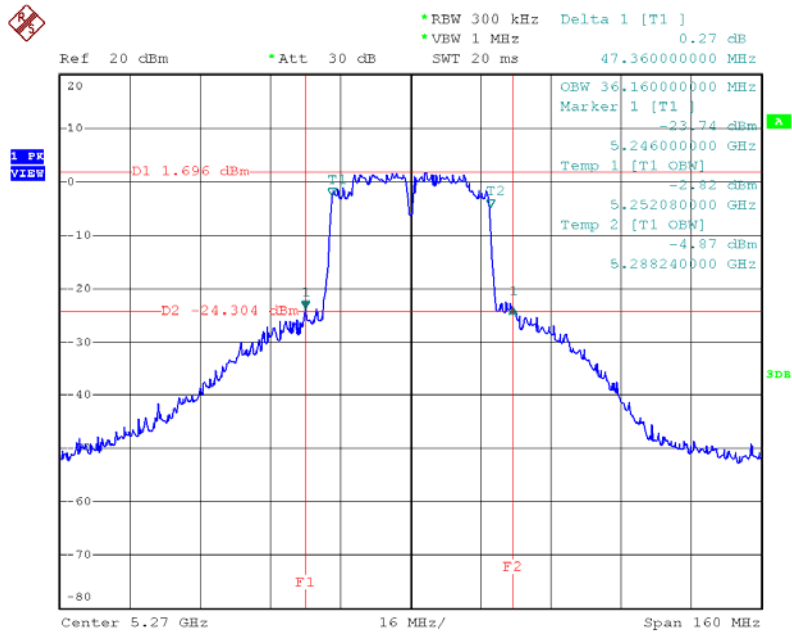

Date: 23.DEC.2011 08:02:47

26 dB Bandwidth Plot on Configuration IEEE 802.11n MCS0 40MHz / Chain A / 5550 MHz

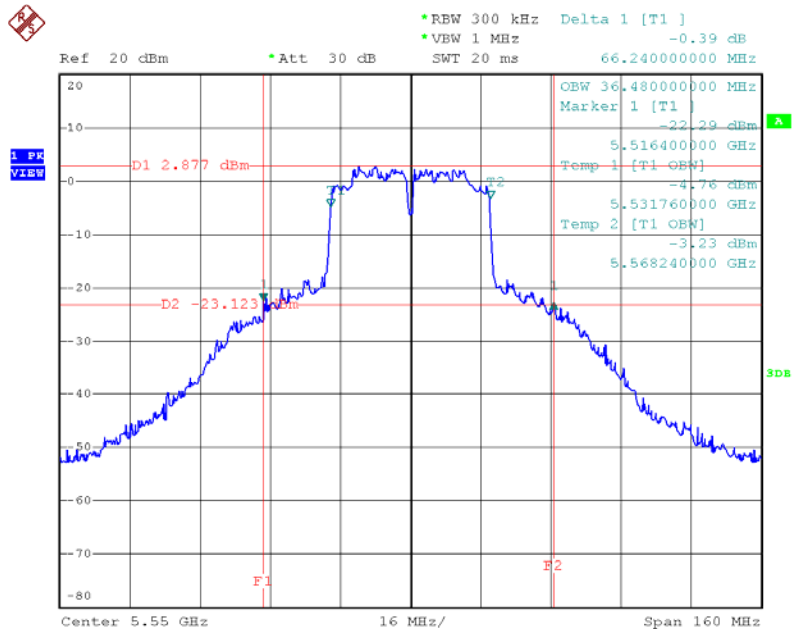

Date: 23.DEC.2011 08:00:57

26 dB Bandwidth Plot on Configuration IEEE 802.11a / Chain B / 5180 MHz

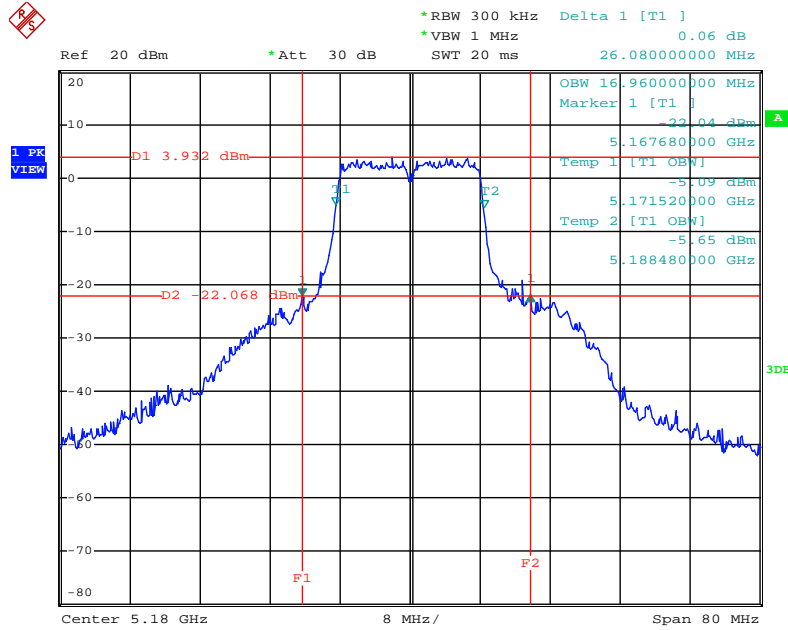

Date: 18.DEC.2011 12:33:18

26 dB Bandwidth Plot on Configuration IEEE 802.11a / Chain B / 5300 MHz

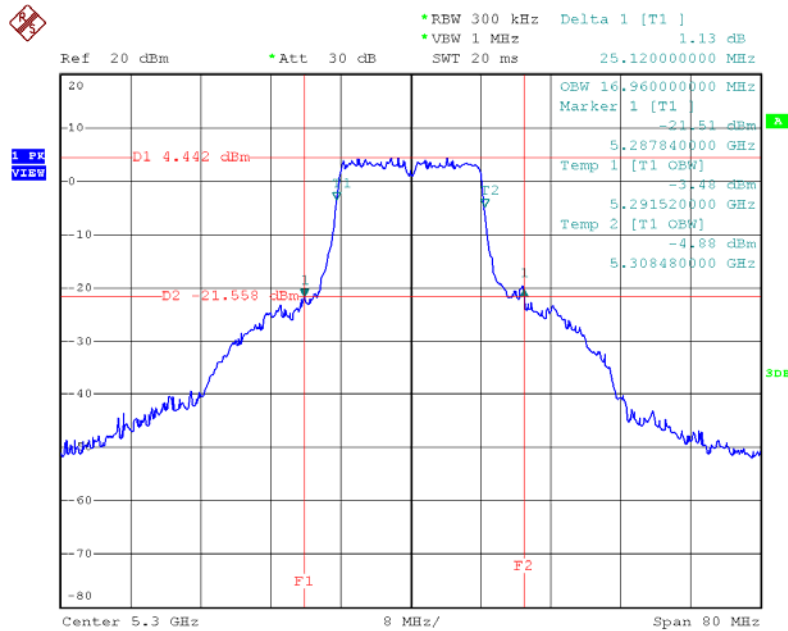

Date: 23.DEC.2011 08:09:34

26 dB Bandwidth Plot on Configuration IEEE 802.11a / Chain B / 5700 MHz

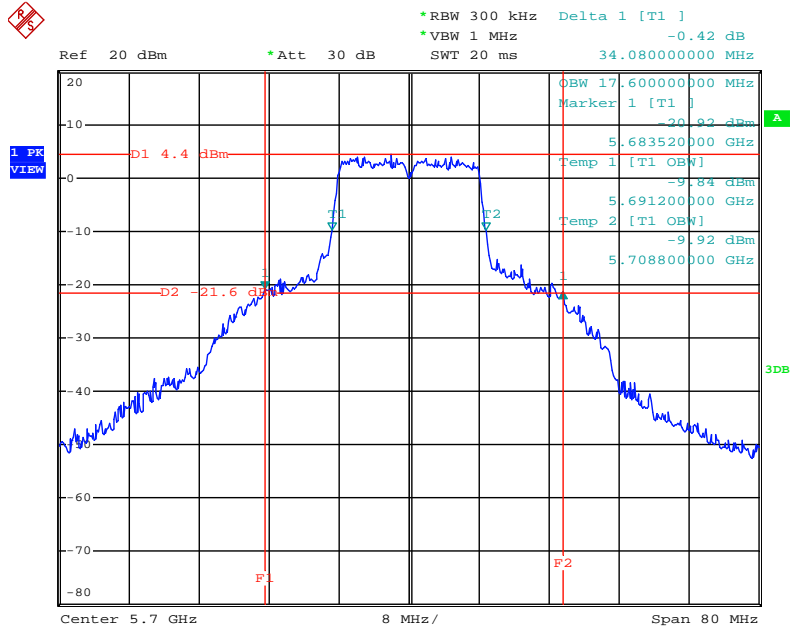

Date: 18.DEC.2011 13:10:36

4.4. Maximum Conducted Output Power Measurement

4.4.1. Summary of Test Result

MAC Address: 00:15:00:85:80:1C DRTU Tool Version: 1.5.2-0308 Driver version: 14.0.4.115

Pwr setting	Test Performed	Limit	Pass / Fail	Result (dBm)
-	Power, 5150 - 5250MHz	15.407(a) (1), (2)	Pass	802.11a: 15.66 802.11an 20MHz: 16.20 802.11an 40MHz: 15.68
-	Power, 5250 - 5350MHz	15.407(a) (1), (2)	Pass	802.11a: 15.68 802.11an 20MHz: 16.12 802.11an 40MHz: 15.64
-	Power, 5470 - 5725MHz	15.407(a) (1), (2)	Pass	802.11a: 16.08 802.11an 20MHz: 16.58 802.11an 40MHz: 16.10

4.4.2. Limit

For the band 5.15~5.25 GHz, the maximum conducted output power over the frequency band of operation shall not exceed the lesser of 50 mW (17dBm) or $4 \text{ dBm} + 10 \log B$, where B is the 26 dB emissions bandwidth in MHz. If transmitting antennas of directional gain greater than 6 dBi are used, both the maximum conducted output power and the peak power spectral density shall be reduced by the amount in dB that the directional gain of the antenna exceeds 6 dBi.

For the 5.25-5.35 GHz and 5.470-5.725 GHz bands, the maximum conducted output power over the frequency bands of operation shall not exceed the lesser of 250 mW (24dBm) or $11 \text{ dBm} + 10 \log B$, where B is the 26-dB emission bandwidth in MHz. If transmitting antennas of directional gain greater than 6 dBi are used, both the maximum conducted output power and the peak power spectral density shall be reduced by the amount in dB that the directional gain of the antenna exceeds 6 dBi.

For the band 5.725~5.825 GHz, the maximum conducted output power over the frequency band of operation shall not exceed the lesser of 1 W or $17 \text{ dBm} + 10 \log B$, where B is the 26-dB emission bandwidth in MHz. In addition, the peak power spectral density shall not exceed 17 dBm in any 1RMHz band. If transmitting antennas of directional gain greater than 6 dBi are used, both the maximum conducted output power and the peak power spectral density shall be reduced by the amount in dB that the directional gain of the antenna exceeds 6 dBi. However, fixed point-to-point U-NII devices operating in this band may employ transmitting antennas with directional gain up to 23 dBi without any corresponding reduction in the transmitter peak output power or peak power spectral density. For fixed, point-to-point U-NII transmitters that employ a directional antenna gain greater than 23 dBi, a 1 dB reduction in peak transmitter power and peak power spectral density for each 1 dB of antenna gain in excess of 23 dBi would be required.

4.4.3. Test Setup Layout

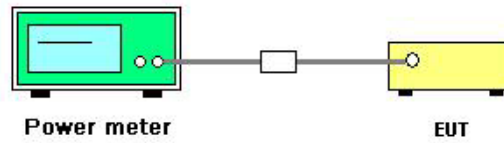

4.4.4. Test Deviation

There is no deviation with the original standard.

4.4.5. EUT Operation during Test

The EUT was programmed to be in continuously transmitting mode.

4.4.6. Test Result of Maximum Conducted Output Power

Temperature	23°C	Humidity	61%
Test Engineer	Denis Su	Configurations	5150-5250MHz Band - Chain A
Test Date	Dec. 18, 2011~Dec. 23, 2011		

Single Chain Operation						
Antenna Gain	3.7	EIRP	97.05	mW	19.87	dBm
Frequency (MHz)	Software Setting	Output Power (Note) (dBm)		Power (W)	Result	
		Measured	Limit			
802.11a						
5180	17.5	15.48	17	0.04	Pass	
5200	18.5	15.66	17	0.04	Pass	
5240	18.5	15.58	17	0.04	Pass	
802.11n HT20						
5180	18.5	15.2	17	0.03	Pass	
5200	19.5	15.86	17	0.04	Pass	
5240	20	16.17	17	0.04	Pass	
802.11n HT40						
5190	14	10.4	17	0.01	Pass	
5230	20	15.44	17	0.03	Pass	
Note	Measured using the power meter average for output power.					

Temperature	23°C	Humidity	61%
Test Engineer	Denis Su	Configurations	5150-5250MHz Band - Chain B
Test Date	Dec. 18, 2011~Dec. 23, 2011		

Single Chain Operation						
Antenna Gain	3.7	EIRP	97.27	mW	19.88	dBm
Frequency (MHz)	Software Setting	Output Power (Note) (dBm)		Power (W)	Result	
		Measured	Limit			
802.11a						
5180	20.5	15.53	17	0.04	Pass	
5200	19.5	15.52	17	0.04	Pass	
5240	19.5	15.44	17	0.03	Pass	
802.11n HT20						
5180	20	14.95	17	0.03	Pass	
5200	20	15.85	17	0.04	Pass	
5240	20.5	16.18	17	0.04	Pass	
802.11n HT40						
5190	15.5	10.38	17	0.01	Pass	
5230	21	15.68	17	0.04	Pass	
Note	Measured using the power meter average for output power.					

Temperature	23°C	Humidity	61%
Test Engineer	Denis Su	Configurations	5150-5250MHz Band – Chain A+B
Test Date	Dec. 18, 2011~Dec. 23, 2011		

Single Chain Operation								
Antenna Gain	Chain A : 3.7 Chain B : 3.7		EIRP	97.62	mW	19.90	dBm	
Frequency (MHz)	Software Setting		Output Power (Note) (dBm)					Result
	Chain A	Chain B	Chain A	Chain B	Total (dBm)	Total (mW)	Limit	
802.11n HT20								
5180	18.5	20.5	13.01	13.01	16.02	40.00	17	Pass
5200	20.5	21	13.06	13.03	16.06	40.32	17	Pass
5240	20.5	21	13.19	13.18	16.20	41.64	17	Pass
802.11n HT40								
5190	17.5	18	9.13	9.2	12.18	16.50	17	Pass
5230	20.5	21	12.4	12.34	15.38	34.52	17	Pass
Note	Measured using the power meter average for output power.							

Temperature	23°C	Humidity	61%
Test Engineer	Denis Su	Configurations	5250-5350MHz Band - Chain A
Test Date	Dec. 21, 2011~Dec. 26, 2011		

Single Chain Operation						
Antenna Gain	3.7	EIRP	94.84	mW	19.77	dBm
Frequency (MHz)	Software Setting	Output Power (Note) (dBm)		Power (W)	Result	
		Measured	Limit			
802.11a						
5260	18.5	15.34	24	0.03	Pass	
5300	19	15.43	24	0.03	Pass	
5320	18.5	15	24	0.03	Pass	
802.11n HT20						
5260	20	16.07	24	0.04	Pass	
5300	20	15.86	24	0.04	Pass	
5320	20	15.46	24	0.04	Pass	
802.11n HT40						
5270	20.5	15.63	24	0.04	Pass	
5310	15.5	11.06	24	0.01	Pass	
Note	Measured using the power meter average for output power.					



Temperature	23°C	Humidity	61%
Test Engineer	Denis Su	Configurations	5250-5350MHz Band - Chain B
Test Date	Dec. 18, 2011~Dec. 23, 2011		

Single Chain Operation						
Antenna Gain	3.7	EIRP	94.41	mW	19.75	dBm
Frequency (MHz)	Software Setting	Output Power (Note) (dBm)		Power (W)	Result	
		Measured Limit				
802.11a						
5260	19.5	15.41	24	0.03	Pass	
5300	20	15.68	24	0.04	Pass	
5320	20	14.9	24	0.03	Pass	
802.11n HT20						
5260	20.5	16.05	24	0.04	Pass	
5300	20.5	15.98	24	0.04	Pass	
5320	21	15.59	24	0.04	Pass	
802.11n HT40						
5270	21	15.64	24	0.04	Pass	
5310	16.5	11.1	24	0.01	Pass	
Note	Measured using the power meter average for output power.					



Temperature	23°C	Humidity	61%
Test Engineer	Denis Su	Configurations	5250-5350MHz Band – Chain A+B
Test Date	Dec. 18, 2011~Dec. 23, 2011		

Single Chain Operation								
Antenna Gain	Chain A : 3.7 Chain B : 3.7		EIRP	95.95	mW	19.82	dBm	
Frequency (MHz)	Software Setting		Output Power (Note) (dBm)					Result
	Chain A	Chain B	Chain A	Chain B	Total (dBm)	Total (mW)	Limit	
802.11n HT20								
5260	20.5	21	13.09	13.08	16.10	40.69	24	Pass
5300	20.5	21	12.92	12.98	15.96	39.45	24	Pass
5320	21	21	13.1	13.12	16.12	40.93	24	Pass
802.11n HT40								
5270	21	21.5	12.41	12.46	15.45	35.04	24	Pass
5310	18.5	18.5	9.44	9.61	12.54	17.93	24	Pass
Note	Measured using the power meter average for output power.							

Temperature	23°C	Humidity	61%
Test Engineer	Denis Su	Configurations	5470-5725MHz Band - Chain A
Test Date	Dec. 18, 2011~Dec. 23, 2011		

Single Chain Operation						
Antenna Gain	4.8	EIRP	122.46	mW	20.88	dBm
Frequency (MHz)	Software Setting	Output Power (Note) (dBm)		Power (W)	Result	
		Measured	Limit			
802.11a						
5500	22	16.08	24	0.04	Pass	
5580	22	15.59	24	0.04	Pass	
5700	23.5	15.63	24	0.04	Pass	
802.11n HT20						
5500	22	15.93	24	0.04	Pass	
5580	23	16.02	24	0.04	Pass	
5700	23.5	15.35	24	0.03	Pass	
802.11n HT40						
5510	22	15.2	24	0.03	Pass	
5550	23	15.6	24	0.04	Pass	
5670	24	15.34	24	0.03	Pass	
Note	Measured using the power meter average for output power.					



Temperature	23°C	Humidity	61%
Test Engineer	Denis Su	Configurations	5470-5725MHz Band - Chain B
Test Date	Dec. 18, 2011 ~ Dec. 23, 2011		

Single Chain Operation						
Antenna Gain	4.8	EIRP	123.31	mW	20.91	dBm
Frequency (MHz)	Software Setting	Output Power (Note) (dBm)		Power (W)	Result	
		Measured	Limit			
802.11a						
5500	22.5	16.02	24	0.04	Pass	
5580	22	15.56	24	0.04	Pass	
5700	25	16.01	24	0.04	Pass	
802.11n HT20						
5500	22.5	15.89	24	0.04	Pass	
5580	23	16.11	24	0.04	Pass	
5700	24	15.86	24	0.04	Pass	
802.11n HT40						
5510	22.5	15.14	24	0.03	Pass	
5550	24	16.1	24	0.04	Pass	
5670	25	15.52	24	0.04	Pass	
Note	Measured using the power meter average for output power.					



Temperature	23°C	Humidity	61%
Test Engineer	Denis Su	Configurations	5470-5725MHz Band – Chain A+B
Test Date	Dec. 18, 2011 ~ Dec. 23, 2011		

Single Chain Operation								
Antenna Gain	Chain A : 4.8 Chain B : 4.8		EIRP	137.26	mW	21.38	dBm	
Frequency (MHz)	Software Setting		Output Power (Note) (dBm)					Result
	Chain A	Chain B	Chain A	Chain B	Total (dBm)	Total (mW)	Limit	
802.11n HT20								
5500	22.5	22	13.2	13.2	16.21	41.79	24	Pass
5580	23	23	13.19	12.93	16.07	40.48	24	Pass
5700	25.5	25	13.55	13.58	16.58	45.45	24	Pass
802.11n HT40								
5510	23	22.5	12.46	12.4	15.44	35.00	24	Pass
5550	23	23.5	12.46	12.65	15.57	36.03	24	Pass
5670	26	25.5	12.92	13.13	16.04	40.15	24	Pass
Note	Measured using the power meter average for output power.							

4.5. Power Spectral Density Measurement

4.5.1. Summary of Test Result

MAC Address: 00:15:00:85:80:1C DRTU Tool Version: 1.5.2-0308 Driver version: 14.0.4.115

Pwr setting	Test Performed	Limit	Pass / Fail	Result (dBm/MHz)
-	Power, 5150 - 5250MHz	15.407(a) (1), (2)	Pass	802.11a: 1.46 802.11n 20MHz: 2.21 802.11n n40MHz: -0.93
-	Power, 5250 - 5350MHz	15.407(a) (1), (2)	Pass	802.11a: 1.70 802.11n 20MHz: 2.09 802.11n n40MHz: -0.70
-	Power, 5470 - 5725MHz	15.407(a) (1), (2)	Pass	802.11a: 2.97 802.11n 20MHz: 2.34 802.11n n40MHz: 0.07

4.5.2. Limit

The power spectral density is defined as the highest level of power in dBm per MHz generated by the transmitter within the power envelope. The following table is power spectral density limits and decrease power density limit rule refer to section 4.3.1.

Frequency Range	Power Spectral Density limit (dBm/MHz)
5.15~5.25 GHz	4
5.25-5.35 GHz	11
5470-5725	11

4.5.3. Test Setup Layout

For radiated emissions below 1GHz

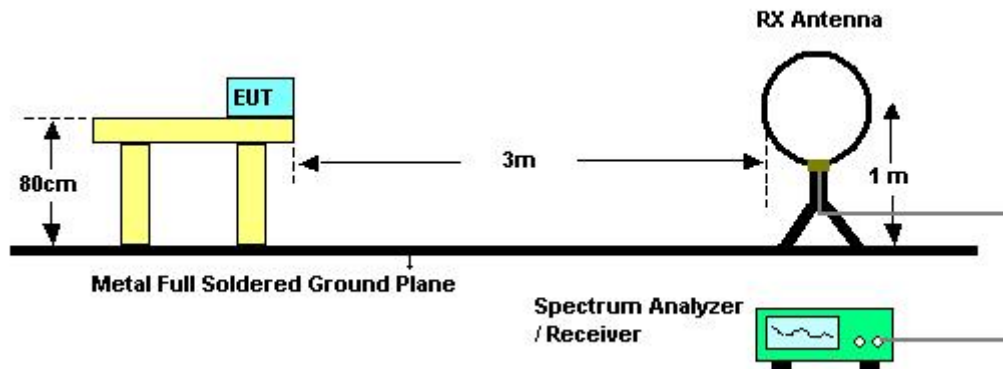

For radiated emissions above 1GHz

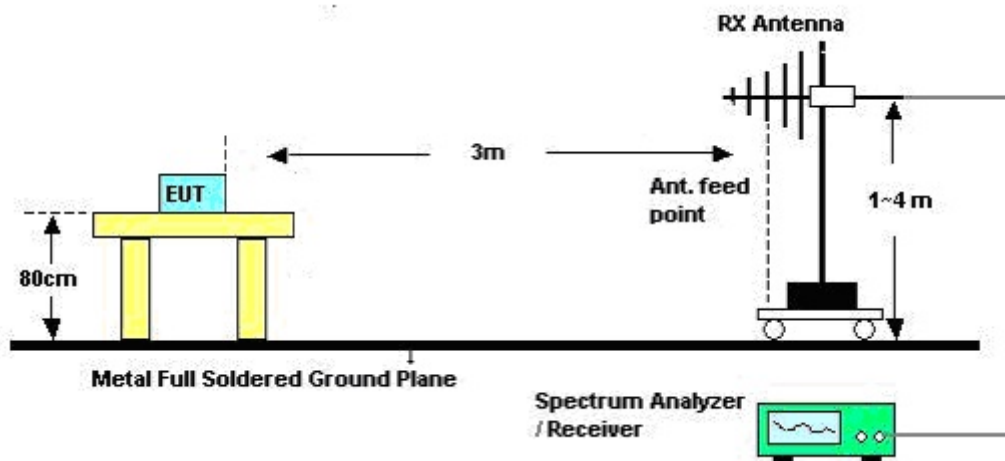

4.5.4. Test Deviation

There is no deviation with the original standard.

4.5.5. EUT Operation during Test

The EUT was programmed to be in continuously transmitting mode.

4.5.6. Test Result of Power Spectral Density

Temperature	23°C	Humidity	61%
Test Engineer	Denis Su	Configurations	5150-5250MHz Band - Chain A
Test Date	Dec. 18, 2011~Dec. 23, 2011		

Single Chain Operation						
Antenna Gain	3.7	EIRP	97.05	mW	19.87	dBm
Frequency (MHz)	Software Setting	PSD (Note1) (dBm/MHz)			Result	
		Measured	FCC Limit	RSS Limit(Note2)		
802.11a						
5180	17.5	-0.5	4	4	Pass	
5200	18.5	1.33	4	4	Pass	
5240	18.5	1.29	4	4	Pass	
802.11n HT20						
5180	18.5	0.07	4	4	Pass	
5200	19.5	1.61	4	4	Pass	
5240	20	2	4	4	Pass	
802.11n HT40						
5190	14	-7.21	4	4	Pass	
5230	20	-1.27	4	4	Pass	
Note 1	measured using a spectrum analyzer. RBW=1MHz, VB=3 MHz, RMS detector, Trace average at least 100 traces in power averaging (i.e., RMS) mode - method SA-2 of KDB780933					
Note 2	For RSS-210 the limit for the 5150 - 5250 MHz band accounts for the antenna gain as the maximum eirp allowed is 10dBm/MHz. The limits are also corrected for instances where the highest measured value of the PSD exceeds the average PSD (calculated from the measured power divided by the measured 99% bandwidth) by more than 3dB by the amount that the measured value exceeds the average by more than 3dB.					



Temperature	23°C	Humidity	61%
Test Engineer	Denis Su	Configurations	5150-5250MHz Band - Chain B
Test Date	Dec. 18, 2011 ~ Dec. 23, 2011		

Single Chain Operation						
Antenna Gain	3.7	EIRP	97.27	mW	19.88	dBm
Frequency (MHz)	Software Setting	PSD (Note1) (dBm/MHz)			Result	
		Measured	FCC Limit	RSS Limit (Note2)		
802.11a						
5180	20.5	1.08	4	4	Pass	
5200	19.5	1.46	4	4	Pass	
5240	19.5	1.33	4	4	Pass	
802.11n HT20						
5180	20	0.33	4	6.3	Pass	
5200	20	1.53	4	6.3	Pass	
5240	20.5	2.21	4	6.3	Pass	
802.11n HT40						
5190	15.5	-6.72	4	4	Pass	
5230	21	-0.93	4	4	Pass	
Note 1	measured using a spectrum analyzer. RBW=1MHz, VB=3 MHz, RMS detector, Trace average at least 100 traces in power averaging (i.e., RMS) mode - method SA-2 of KDB780933					
Note 2	For RSS-210 the limit for the 5150 - 5250 MHz band accounts for the antenna gain as the maximum eirp allowed is 10dBm/MHz. The limits are also corrected for instances where the highest measured value of the PSD exceeds the average PSD (calculated from the measured power divided by the measured 99% bandwidth) by more than 3dB by the amount that the measured value exceeds the average by more than 3dB.					



Temperature	23°C	Humidity	61%
Test Engineer	Denis Su	Configurations	5150-5250MHz Band – Chain A+B
Test Date	Dec. 18, 2011 ~ Dec. 23, 2011		

Single Chain Operation								
Antenna Gain	Chain A : 3.7 Chain B : 3.7		EIRP	97.62	mW	19.90	dBm	
Frequency (MHz)	Software Setting		PSD (Note1) (dBm/MHz)					Result
	Chain A	Chain B	Chain A	Chain B	Total	FCC Limit	RSS Limit (Note2)	
802.11n HT20								
5180	18.5	20.5	-3.77	-2.67	-0.17	4.00	4	Pass
5200	20.5	21	-1.32	-1.34	1.68	4.00	4	Pass
5240	20.5	21	-1.31	-1.55	1.58	4.00	4	Pass
802.11n HT40								
5190	17.5	18	-7.89	-8.17	-5.02	4.00	4	Pass
5230	20.5	21	-3.98	-4.3	-1.13	4.00	4	Pass
Note 1	measured using a spectrum analyzer. RBW=1MHz, VB=3 MHz, RMS detector, Trace average at least 100 traces in power averaging (i.e., RMS) mode - method SA-2 of KDB780933							
Note 2	For RSS-210 the limit for the 5150 - 5250 MHz band accounts for the antenna gain as the maximum eirp allowed is 10dBm/MHz. The limits are also corrected for instances where the highest measured value of the PSD exceeds the average PSD (calculated from the measured power divided by the measured 99% bandwidth) by more than 3dB by the amount that the measured value exceeds the average by more than 3dB.							

Temperature	23°C	Humidity	61%
Test Engineer	Denis Su	Configurations	5250-5350MHz Band - Chain A
Test Date	Dec. 18, 2011 ~ Dec. 23, 2011		

Single Chain Operation						
Antenna Gain	3.7	EIRP	94.84	mW	19.77	dBm
Frequency (MHz)	Software Setting	PSD (Note1) dBm/MHz			Result	
		Measured	FCC Limit	RSS Limit (Note2)		
802.11a						
5260	18.5	1.18	11	11	Pass	
5300	19	1.42	11	11	Pass	
5320	18.5	1.19	11	11	Pass	
802.11n HT20						
5260	20	1.9	11	11	Pass	
5300	20	1.55	11	11	Pass	
5320	20	1.54	11	11	Pass	
802.11n HT40						
5270	20.5	-1.2	11	11	Pass	
5310	15.5	-5.48	11	11	Pass	
Note 1	measured using a spectrum analyzer. RBW=1MHz, VB=3 MHz, RMS detector, Trace average at least 100 traces in power averaging (i.e., RMS) mode - method SA-2 of KDB780933					
Note 2	For RSS-210 the limit for the 5150 - 5250 MHz band accounts for the antenna gain as the maximum eirp allowed is 10dBm/MHz. The limits are also corrected for instances where the highest measured value of the PSD exceeds the average PSD (calculated from the measured power divided by the measured 99% bandwidth) by more than 3dB by the amount that the measured value exceeds the average by more than 3dB.					

Temperature	23°C	Humidity	61%
Test Engineer	Denis Su	Configurations	5250-5350MHz Band - Chain B
Test Date	Dec. 18, 2011~Dec. 23, 2011		

Single Chain Operation						
Antenna Gain	3.7	EIRP	94.41	mW	19.75	dBm
Frequency (MHz)	Software Setting	PSD (Note1) (dBm/MHz)			Result	
		Measured	FCC Limit	RSS Limit (Note2)		
802.11a						
5260	19.5	1.25	11	11	Pass	
5300	20	1.7	11	11	Pass	
5320	20	0.53	11	11	Pass	
802.11n HT20						
5260	20.5	2.09	11	11	Pass	
5300	20.5	1.76	11	11	Pass	
5320	21	1.2	11	11	Pass	
802.11n HT40						
5270	21	-0.93	11	11	Pass	
5310	16.5	-5.07	11	11	Pass	
Note 1	measured using a spectrum analyzer. RBW=1MHz, VB=3 MHz, RMS detector, Trace average at least 100 traces in power averaging (i.e., RMS) mode - method SA-2 of KDB780933					
Note 2	For RSS-210 the limit for the 5150 - 5250 MHz band accounts for the antenna gain as the maximum eirp allowed is 10dBm/MHz. The limits are also corrected for instances where the highest measured value of the PSD exceeds the average PSD (calculated from the measured power divided by the measured 99% bandwidth) by more than 3dB by the amount that the measured value exceeds the average by more than 3dB.					



Temperature	23°C	Humidity	61%
Test Engineer	Denis Su	Configurations	5250-5350MHz Band – Chain A+B
Test Date	Dec. 18, 2011 ~ Dec. 23, 2011		

Single Chain Operation								
Antenna Gain	Chain A : 3.7 Chain B : 3.7		EIRP	95.95	mW	19.82	dBm	
Frequency (MHz)	Software Setting		PSD (Note1) (dBm/MHz)					Result
	Chain A	Chain B	Chain A	Chain B	Total	FCC Limit	RSS Limit (Note2)	
802.11n HT20								
5260	20.5	21	-1.12	-1.35	1.78	11.00	11	Pass
5300	20.5	21	-1.17	-1.48	1.69	11.00	11	Pass
5320	21	21	-0.91	-1.36	1.88	11.00	11	Pass
802.11n HT40								
5270	21	21.5	-3.81	-3.62	-0.70	11.00	11	Pass
5310	18.5	18.5	-6.55	-6.52	-3.52	11.00	11	Pass
Note 1	measured using a spectrum analyzer. RBW=1MHz, VB=3 MHz, RMS detector, Trace average at least 100 traces in power averaging (i.e., RMS) mode - method SA-2 of KDB780933							
Note 2	For RSS-210 the limit for the 5150 - 5250 MHz band accounts for the antenna gain as the maximum eirp allowed is 10dBm/MHz. The limits are also corrected for instances where the highest measured value of the PSD exceeds the average PSD (calculated from the measured power divided by the measured 99% bandwidth) by more than 3dB by the amount that the measured value exceeds the average by more than 3dB.							

Temperature	23°C	Humidity	61%
Test Engineer	Denis Su	Configurations	5470-5725MHz Band - Chain A
Test Date	Dec. 18, 2011 ~ Dec. 23, 2011		

Single Chain Operation						
Antenna Gain	4.8	EIRP	122.46	mW	20.88	dBm
Frequency (MHz)	Software Setting	PSD (Note1) (dBm/MHz)			Result	
		Measured	FCC Limit	RSS Limit (Note2)		
802.11a						
5500	22	1.24	11	11	Pass	
5580	22	1.92	11	11	Pass	
5700	23.5	0.77	11	11	Pass	
802.11n HT20						
5500	22	0.89	11	11	Pass	
5580	23	2.27	11	11	Pass	
5700	23.5	0.08	11	11	Pass	
802.11n HT40						
5510	22	-1.44	11	11	Pass	
5550	23	-0.72	11	11	Pass	
5670	24	-2.09	11	11	Pass	
Note 1	measured using a spectrum analyzer. RBW=1MHz, VB=3 MHz, RMS detector, Trace average at least 100 traces in power averaging (i.e., RMS) mode - method SA-2 of KDB780933					
Note 2	For RSS-210 the limit for the 5150 - 5250 MHz band accounts for the antenna gain as the maximum eirp allowed is 10dBm/MHz. The limits are also corrected for instances where the highest measured value of the PSD exceeds the average PSD (calculated from the measured power divided by the measured 99% bandwidth) by more than 3dB by the amount that the measured value exceeds the average by more than 3dB.					

Temperature	23°C	Humidity	61%
Test Engineer	Denis Su	Configurations	5470-5725MHz Band - Chain B
Test Date	Dec. 18, 2011~Dec. 23, 2011		

Single Chain Operation						
Antenna Gain	4.8	EIRP	123.31	mW	20.91	dBm
Frequency (MHz)	Software Setting	PSD (Note1) dBm/MHz			Result	
		Measured	FCC Limit	RSS Limit (Note2)		
802.11a						
5500	22.5	2.97	11	11	Pass	
5580	22	1.86	11	11	Pass	
5700	25	1.25	11	11	Pass	
802.11n HT20						
5500	22.5	2.24	11	11	Pass	
5580	23	2.34	11	11	Pass	
5700	24	0.38	11	11	Pass	
802.11n HT40						
5510	22.5	-0.98	11	11	Pass	
5550	24	0.07	11	11	Pass	
5670	25	-1.69	11	11	Pass	
Note 1	measured using a spectrum analyzer. RBW=1MHz, VB=3 MHz, RMS detector, Trace average at least 100 traces in power averaging (i.e., RMS) mode - method SA-2 of KDB780933					
Note 2	For RSS-210 the limit for the 5150 - 5250 MHz band accounts for the antenna gain as the maximum eirp allowed is 10dBm/MHz. The limits are also corrected for instances where the highest measured value of the PSD exceeds the average PSD (calculated from the measured power divided by the measured 99% bandwidth) by more than 3dB by the amount that the measured value exceeds the average by more than 3dB.					

Temperature	23°C	Humidity	61%
Test Engineer	Denis Su	Configurations	5470-5725MHz Band – Chain A+B
Test Date	Dec. 18, 2011~Dec. 23, 2011		

Single Chain Operation								
Antenna Gain	Chain A : 4.8 Chain B : 4.8		EIRP	137.26	mW	21.38	dBm	
Frequency (MHz)	Software Setting		PSD (Note1) (dBm/MHz)					Result
	Chain A	Chain B	Chain A	Chain B	Total	FCC Limit	RSS Limit (Note2)	
802.11n HT20								
5500	22.5	22	-0.83	-1.32	1.94	11.00	11	Pass
5580	23	23	-0.87	-1.03	2.06	11.00	11	Pass
5700	25.5	25	-1.22	-0.89	1.96	11.00	11	Pass
802.11n HT40								
5510	23	22.5	-3.83	-3.84	-0.82	11.00	11	Pass
5550	23	23.5	-3.27	-3.34	-0.29	11.00	11	Pass
5670	26	25.5	-4.12	-4.61	-1.35	11.00	11	Pass
Note 1	measured using a spectrum analyzer. RBW=1MHz, VB=3 MHz, RMS detector, Trace average at least 100 traces in power averaging (i.e., RMS) mode - method SA-2 of KDB780933							
Note 2	For RSS-210 the limit for the 5150 - 5250 MHz band accounts for the antenna gain as the maximum eirp allowed is 10dBm/MHz. The limits are also corrected for instances where the highest measured value of the PSD exceeds the average PSD (calculated from the measured power divided by the measured 99% bandwidth) by more than 3dB by the amount that the measured value exceeds the average by more than 3dB.							

Note: All the test values were listed in the report.

For plots, only the channel with maximum results was shown.

Power Density Plot on Configuration IEEE 802.11n MCS0 20MHz / Chain B / 5240 MHz

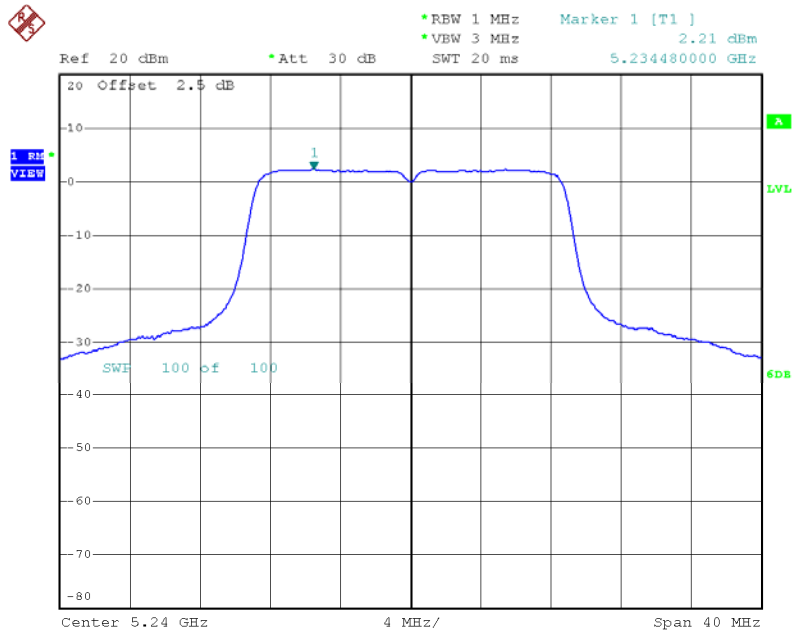

Date: 23.DEC.2011 09:28:03

Power Density Plot on Configuration IEEE 802.11n MCS0 20MHz / Chain B / 5260 MHz

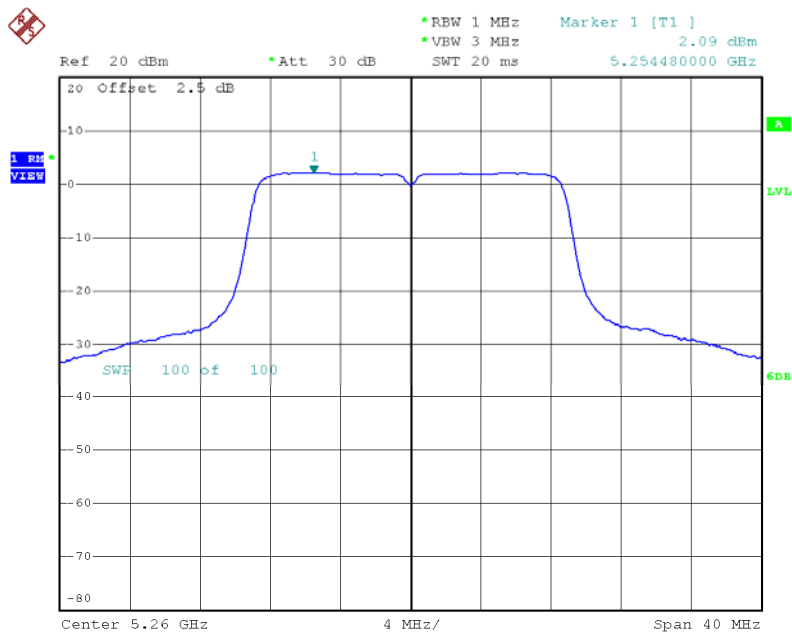

Date: 23.DEC.2011 09:28:31

Power Density Plot on Configuration IEEE 802.11n MCS0 20MHz / Chain B / 5580 MHz

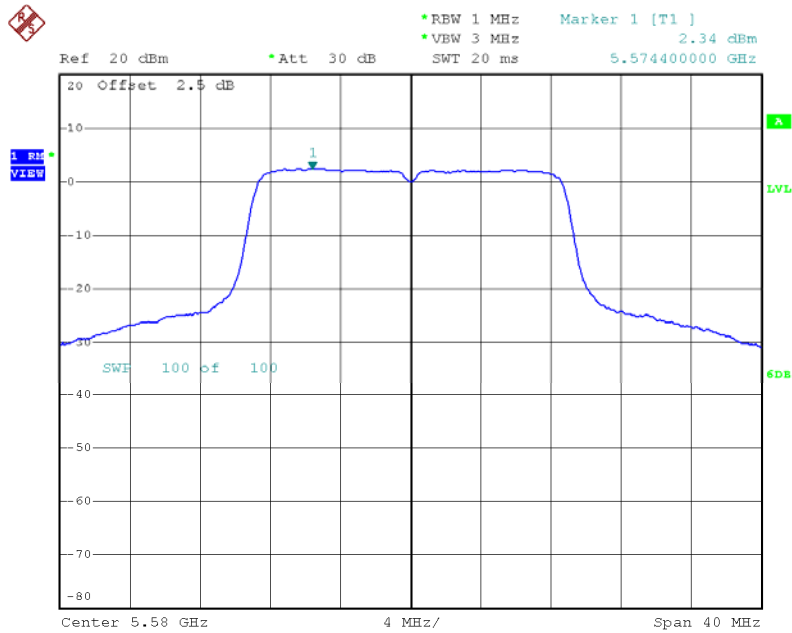

Date: 23.DEC.2011 09:30:46

Power Density Plot on Configuration IEEE 802.11n MCS0 40MHz / Chain B / 5230 MHz

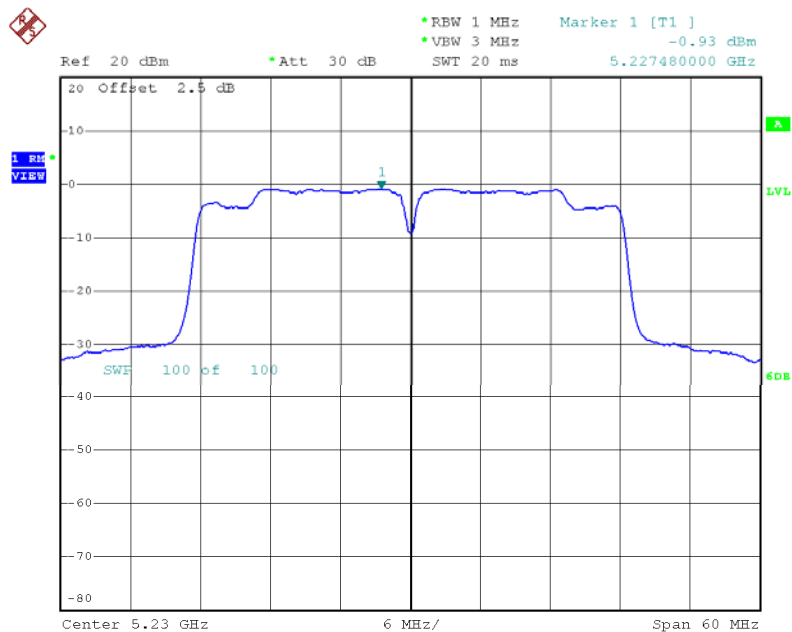

Date: 23.DEC.2011 09:26:59

Power Density Plot on Configuration IEEE 802.11n MCS0 40MHz / Chaing B / 5270 MHz

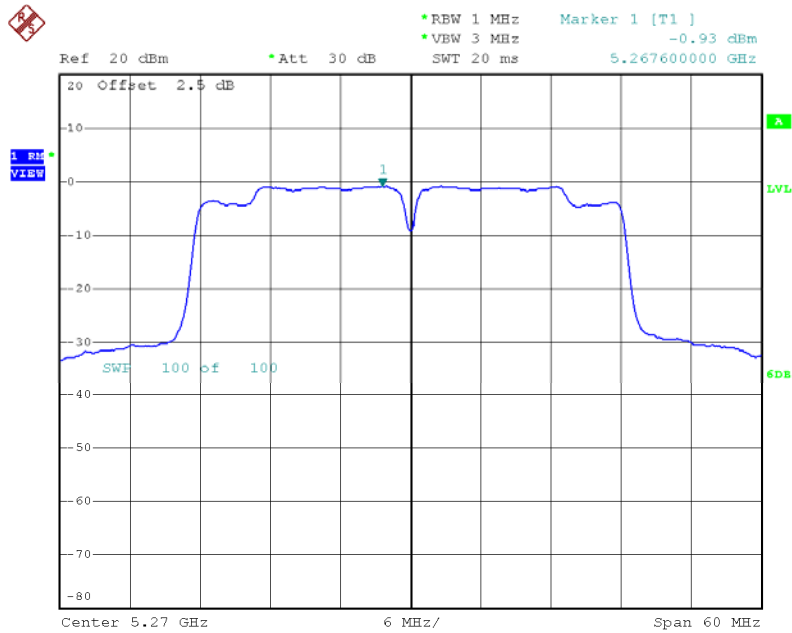

Date: 23.DEC.2011 09:26:01

Power Density Plot on Configuration IEEE 802.11n MCS0 40MHz / Chain B / 5550 MHz

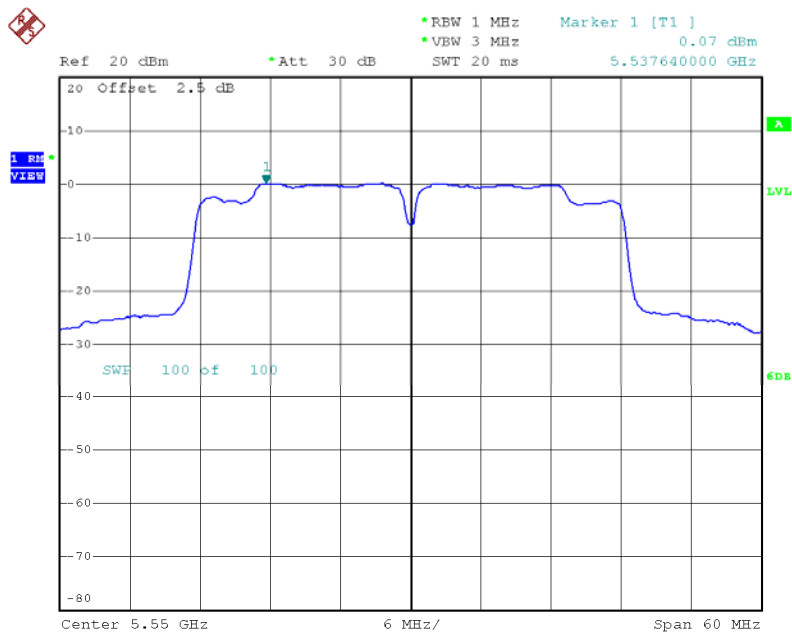

Date: 23.DEC.2011 09:24:29

Power Density Plot on Configuration IEEE 802.11a / Chain B / 5200 MHz

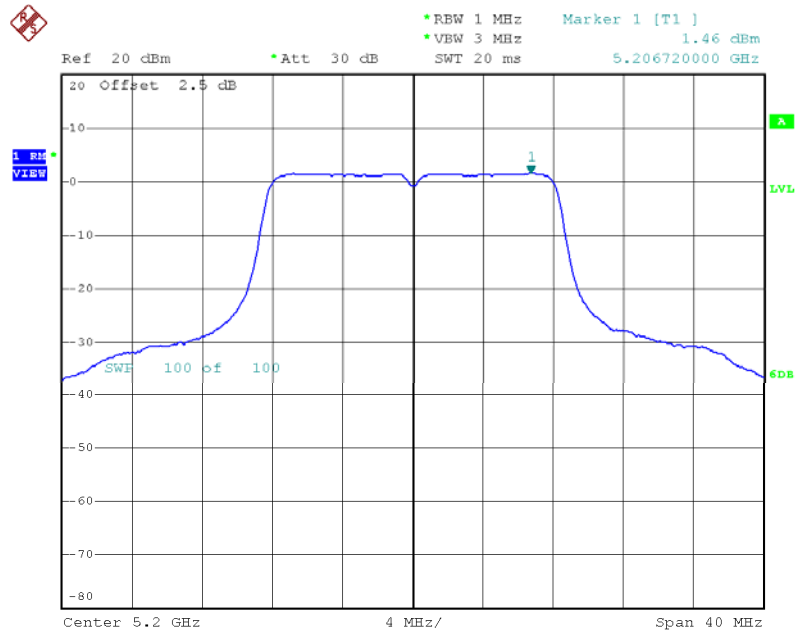

Date: 23.DEC.2011 09:35:02

Power Density Plot on Configuration IEEE 802.11a / Chain B / 5300 MHz

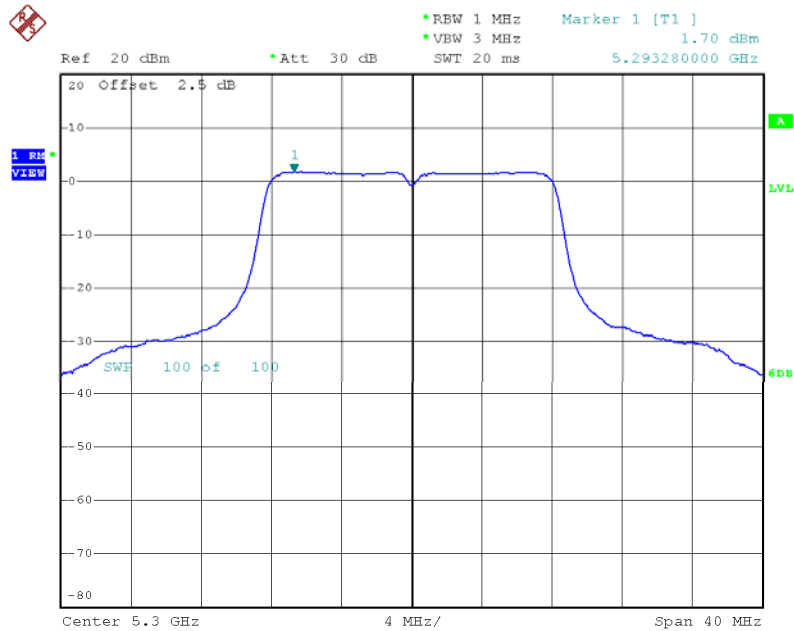

Date: 23.DEC.2011 09:33:38

Power Density Plot on Configuration IEEE 802.11a / Chain B / 5500 MHz

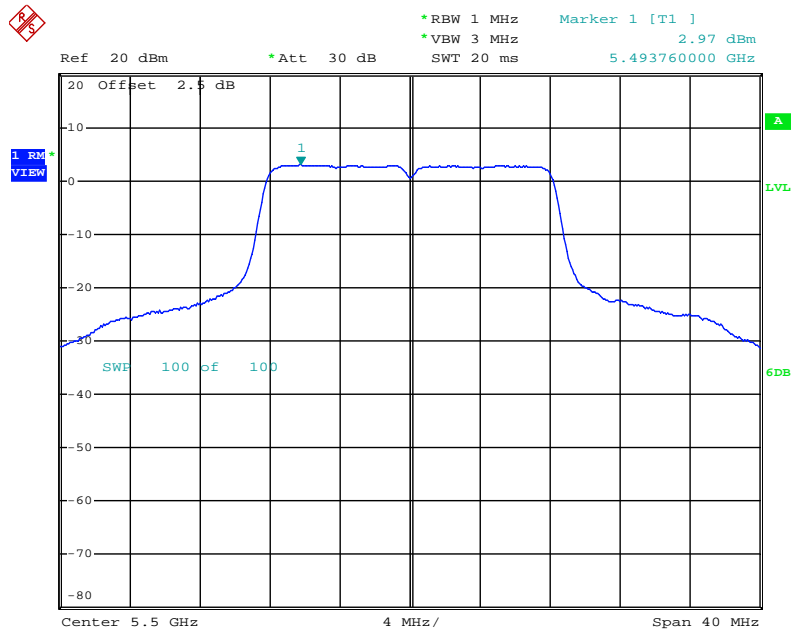

Date: 18.DEC.2011 13:02:10

4.6. Peak Excursion Measurement

4.6.1. Summary of Test Result

MAC Address: 00:15:00:85:80:1C DRTU Tool Version: 1.5.2-0308 Driver version: 14.0.4.115

Pwr setting	Test Performed	Limit	Pass / Fail	Result (dBm/MHz)
-	Peak Excursion Envelope	15.407(a) (6)13dB	Pass	12.48 dB

4.6.2. Limit

The ratio of the peak excursion of the modulation envelope (measured using a peak hold function) to the maximum conducted output power (measured as specified above) shall not exceed 13 dB across any 1 MHz bandwidth or the emissions bandwidth whichever is less.

4.6.3. Measuring Instruments and Setting

Please refer to section 5 of equipments list in this report. The following table is the setting of the spectrum analyzer.

Spectrum Parameter	Setting
Attenuation	Auto
Span Frequency	Encompass the entire emissions bandwidth (EBW) of the signal
RB	1000 kHz (Peak Trace) / 1000 kHz (Average Trace)
VB	3000 kHz (Peak Trace) / 300 kHz (Average Trace)
Detector	Peak (Peak Trace) / Sample (Average Trace)
Trace	Max Hold
Sweep Time	60s

4.6.4. Test Procedures

1. The test procedure is the same as section 4.6.3.
2. Trace A, Set RBW = 1MHz, VBW = 3MHz, Span >26dB bandwidth, Max. hold.
3. Delta Mark trace A Maximum frequency and trace B same frequency.
4. Repeat the above procedure until measurements for all frequencies were complete.

4.6.5. Test Setup Layout

For radiated emissions below 1GHz

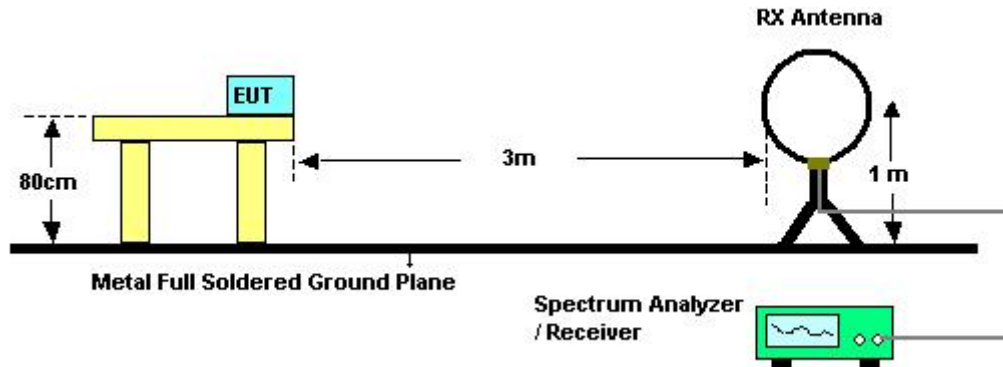

For radiated emissions above 1GHz

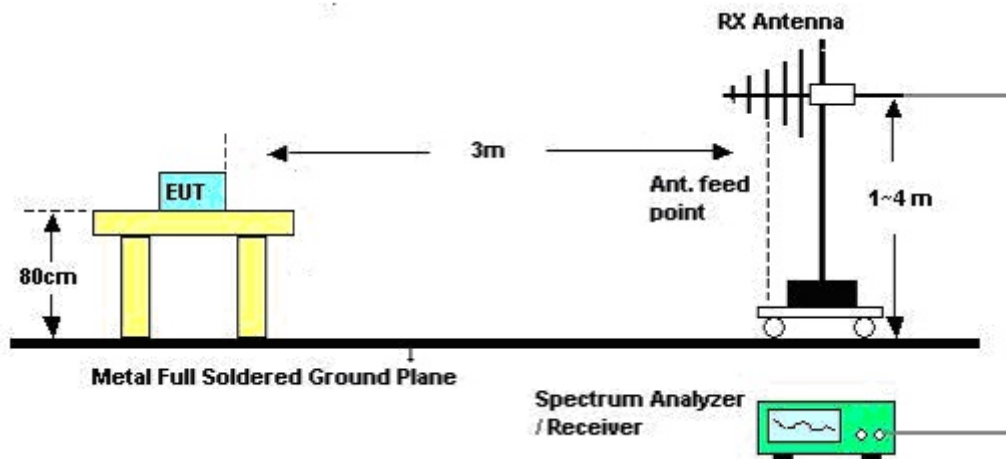

4.6.6. Test Deviation

There is no deviation with the original standard.

4.6.7. EUT Operation during Test

The EUT was programmed to be in continuously transmitting mode.

4.6.8. Test Result of Peak Excursion

Temperature	23°C	Humidity	61%
Test Engineer	Denis Su	Configurations	5150-5250MHz Band - Chain A
Test Date	Dec. 18, 2011~Dec. 23, 2011		

Frequency(MHz)	Peak Excursion(dB)		Result
	Measured	Limit	
802.11a			
5180	8.78	13	Pass
5200	8.73	13	Pass
5240	8.62	13	Pass
802.11n HT20			
5180	8.39	13	Pass
5200	9.62	13	Pass
5240	9.59	13	Pass
802.11n HT40			
5190	12.48	13	Pass
5230	10.13	13	Pass

Temperature	23°C	Humidity	61%
Test Engineer	Denis Su	Configurations	5150-5250MHz Band - Chain B
Test Date	Dec. 18, 2011~Dec. 23, 2011		

Frequency(MHz)	Peak Excursion(dB)		Result
	Measured	Limit	
802.11a			
5180	9.02	13	Pass
5200	8.85	13	Pass
5240	9.14	13	Pass
802.11n HT20			
5180	9.81	13	Pass
5200	9.06	13	Pass
5240	9.39	13	Pass
802.11n HT40			
5190	12.39	13	Pass
5230	10.65	13	Pass

Temperature	23°C	Humidity	61%
Test Engineer	Denis Su	Configurations	5150-5250MHz Band – Chain A+B
Test Date	Dec. 18, 2011~Dec. 23, 2011		

Frequency(MHz)	Peak Excursion(dB)		Result
	Measured	Limit	
802.11n HT20			
5180	10.33	13	Pass
5200	10.49	13	Pass
5240	11.37	13	Pass
802.11n HT40			
5190	12.37	13	Pass
5230	10.63	13	Pass



Temperature	23°C	Humidity	61%
Test Engineer	Denis Su	Configurations	5250-5350MHz Band - Chain A
Test Date	Dec. 18, 2011~Dec. 23, 2011		

Frequency(MHz)	Peak Excursion(dB)		Result
	Measured	Limit	
802.11a			
5260	8.03	13	Pass
5300	10.9	13	Pass
5320	8.84	13	Pass
802.11n HT20			
5260	9.44	13	Pass
5300	8.95	13	Pass
5320	8.87	13	Pass
802.11n HT40			
5270	9.67	13	Pass
5310	12.23	13	Pass



Temperature	23°C	Humidity	61%
Test Engineer	Denis Su	Configurations	5250-5350MHz Band - Chain B
Test Date	Dec. 18, 2011~Dec. 23, 2011		

Frequency(MHz)	Peak Excursion(dB)		Result
	Measured	Limit	
802.11a			
5260	9.82	13	Pass
5300	9.09	13	Pass
5320	9.6	13	Pass
802.11n HT20			
5260	8.99	13	Pass
5300	9.14	13	Pass
5320	10.91	13	Pass
802.11n HT40			
5270	11.85	13	Pass
5310	12.32	13	Pass



Temperature	23°C	Humidity	61%
Test Engineer	Denis Su	Configurations	5250-5350MHz Band – Chain A+B
Test Date	Dec. 18, 2011~Dec. 23, 2011		

Frequency(MHz)	Peak Excursion(dB)		Result
	Measured	Limit	
802.11n HT20			
5260	9.93	13	Pass
5300	9.25	13	Pass
5320	11.04	13	Pass
802.11n HT40			
5270	12.4	13	Pass
5310	11.61	13	Pass



Temperature	23°C	Humidity	61%
Test Engineer	Denis Su	Configurations	5470-5725MHz Band - Chain A
Test Date	Dec. 18, 2011~Dec. 23, 2011		

Frequency(MHz)	Peak Excursion(dB)		Result
	Measured	Limit	
802.11a			
5500	8.8	13	Pass
5580	8.77	13	Pass
5700	9.64	13	Pass
802.11n HT20			
5500	8.71	13	Pass
5580	9.78	13	Pass
5700	9.05	13	Pass
802.11n HT40			
5510	12.25	13	Pass
5550	10.3	13	Pass
5670	12.28	13	Pass



Temperature	23°C	Humidity	61%
Test Engineer	Denis Su	Configurations	5470-5725MHz Band - Chain B
Test Date	Dec. 18, 2011~Dec. 23, 2011		

Frequency(MHz)	Peak Excursion(dB)		Result
	Measured	Limit	
802.11a			
5500	10.28	13	Pass
5580	8.03	13	Pass
5700	8.4	13	Pass
802.11n HT20			
5500	8.75	13	Pass
5580	9.92	13	Pass
5700	9.26	13	Pass
802.11n HT40			
5510	11.94	13	Pass
5550	11.42	13	Pass
5670	11.72	13	Pass

Temperature	23°C	Humidity	61%
Test Engineer	Denis Su	Configurations	5470-5725MHz Band – Chain A+B
Test Date	Dec. 18, 2011~Dec. 23, 2011		

Frequency(MHz)	Peak Excursion(dB)		Result
	Measured	Limit	
802.11n HT20			
5500	9.66	13	Pass
5580	9.58	13	Pass
5700	10.06	13	Pass
802.11n HT40			
5510	10.38	13	Pass
5550	12.03	13	Pass
5670	11.46	13	Pass

Note: All the test values were listed in the report.

For plots, only the channel with maximum results was shown.

Peak Excursion Plot on Configuration IEEE 802.11n MCS0 20MHz / Chain A + Chain B / 5240 MHz

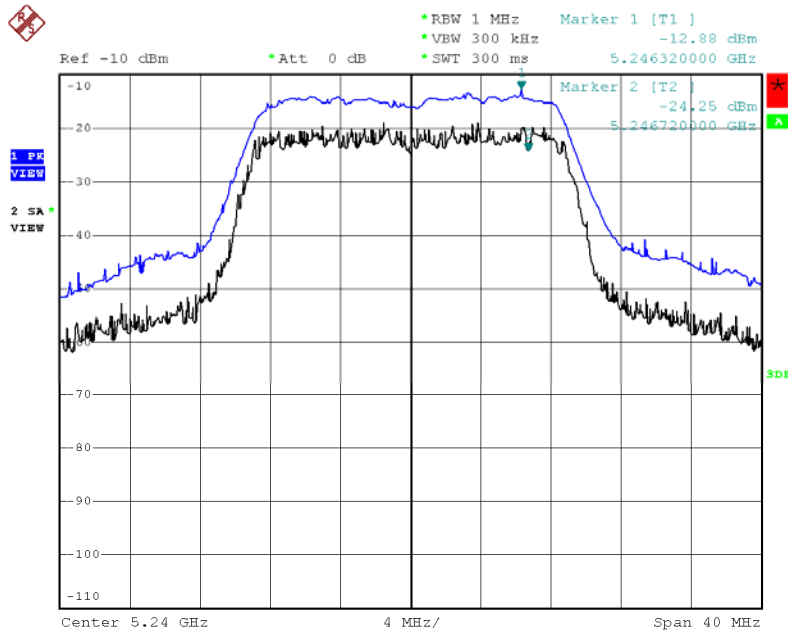

Date: 23.DEC.2011 10:21:22

Peak Excursion Plot on Configuration IEEE 802.11n MCS0 20MHz / Chain A + Chain B / 5320 MHz

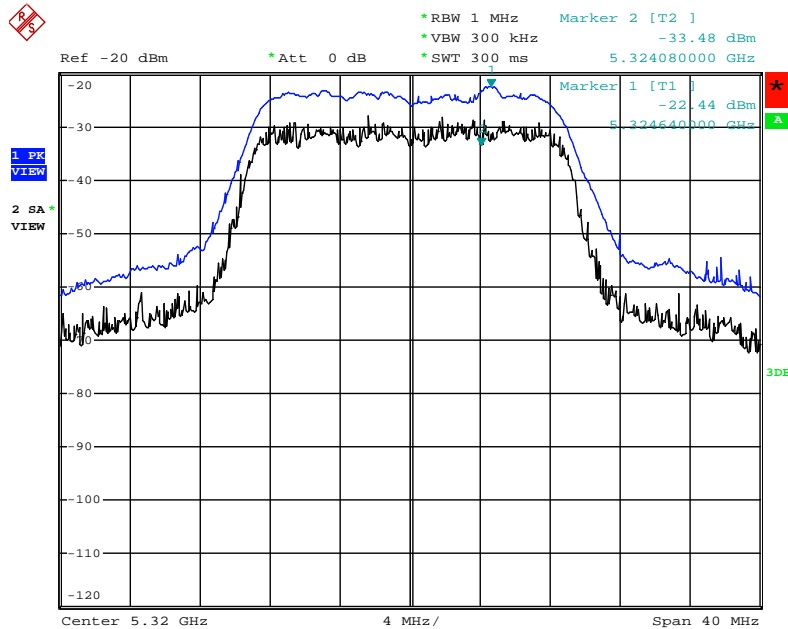

Date: 18.DEC.2011 19:33:52

Peak Excursion Plot on Configuration IEEE 802.11n MCS0 20MHz / Chain A + Chain B / 5700 MHz

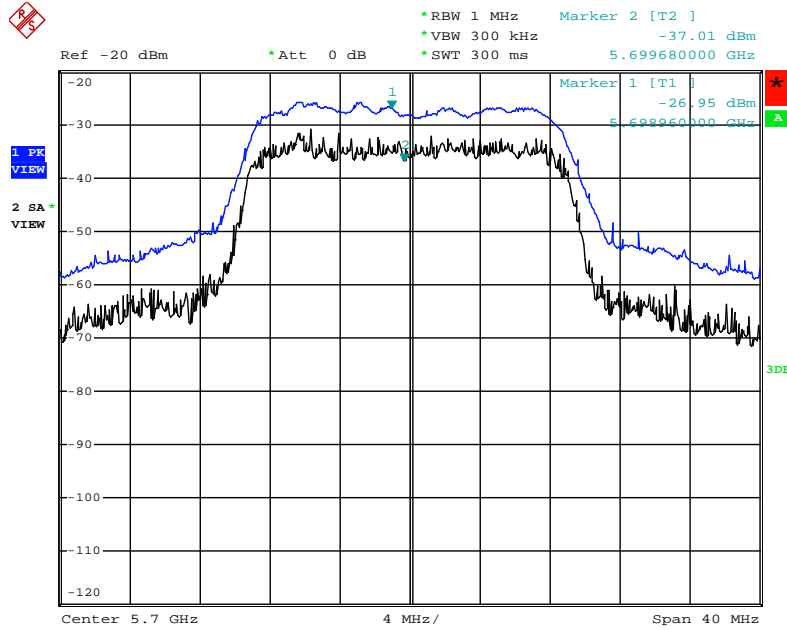

Date: 18.DEC.2011 19:38:48

Peak Excursion Plot on Configuration IEEE 802.11n MCS0 40MHz / Chain A / 5190 MHz

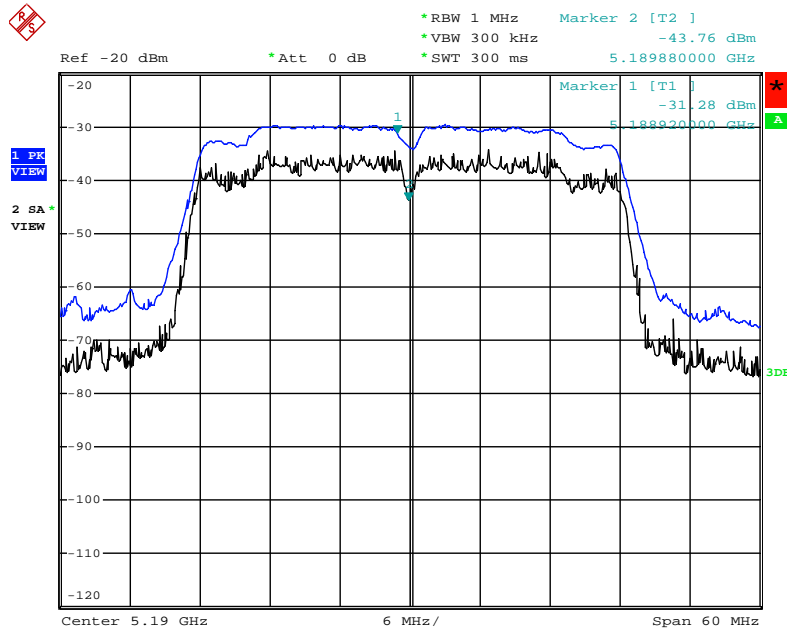

Date: 18.DEC.2011 18:48:29

Peak Excursion Plot on Configuration IEEE 802.11n MCS0 40MHz / Chain A + Chain B / 5270 MHz

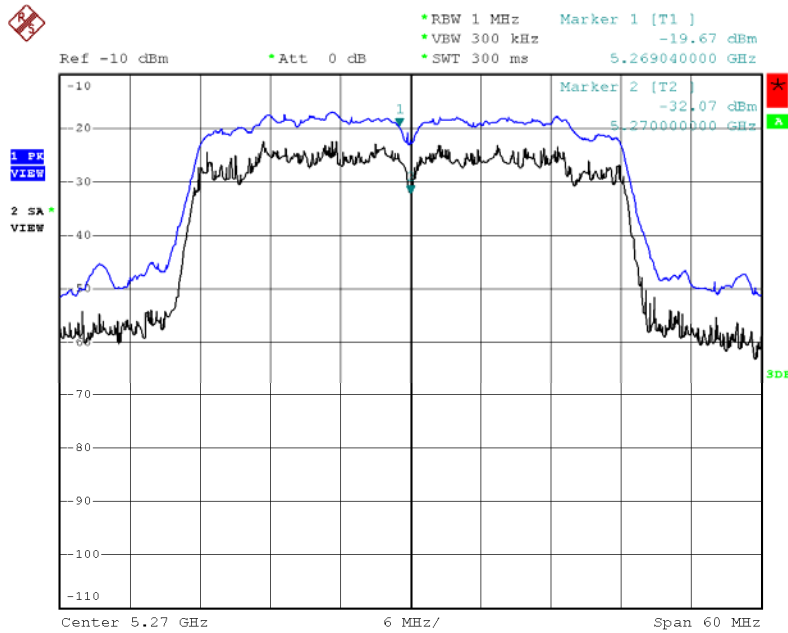

Date: 23.DEC.2011 10:25:26

Peak Excursion Plot on Configuration IEEE 802.11n MCS0 40MHz / Chain A / 5670 MHz

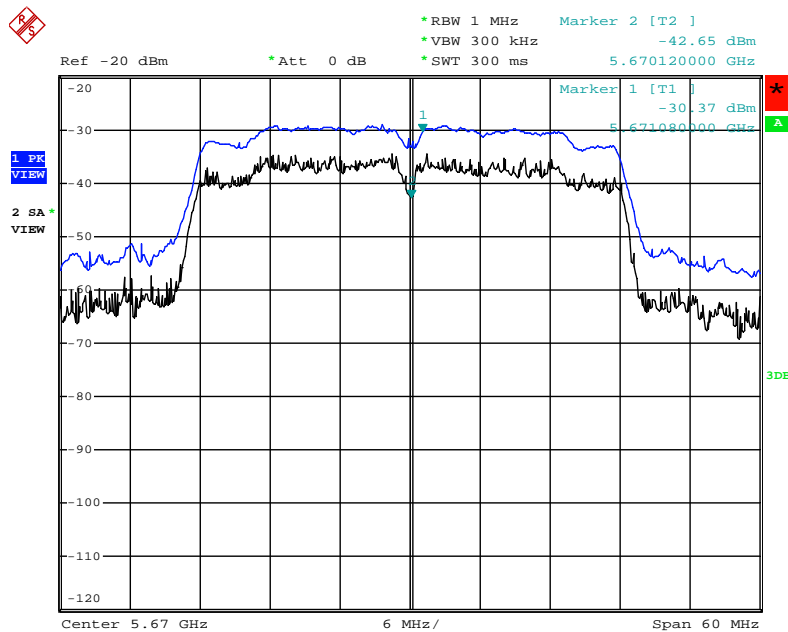

Date: 18.DEC.2011 19:14:54

Peak Excursion Plot on Configuration IEEE 802.11 a / Chain B / 5240 MHz

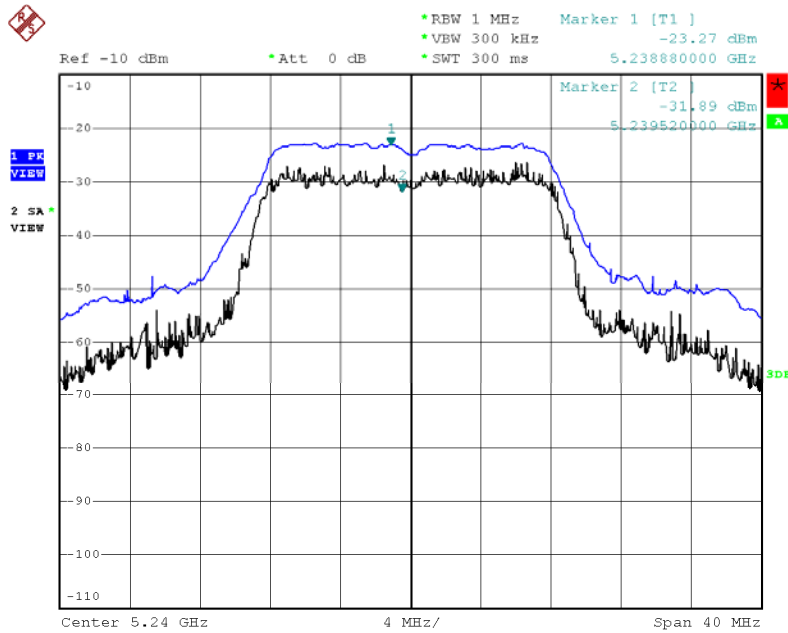

Date: 23.DEC.2011 09:47:59

Peak Excursion Plot on Configuration IEEE 802.11 a / Chain A / 5300 MHz

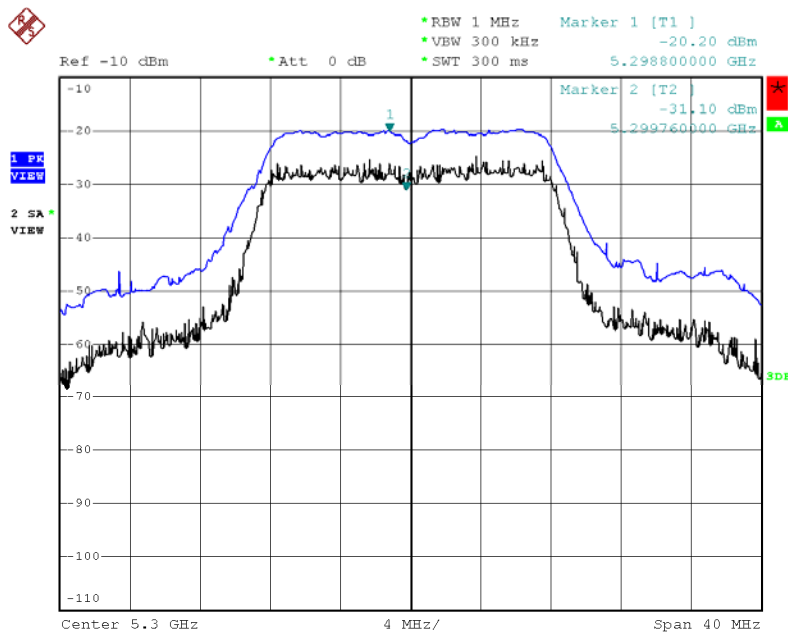

Date: 23.DEC.2011 09:51:50

Peak Excursion Plot on Configuration IEEE 802.11 a / Chain B / 5500 MHz

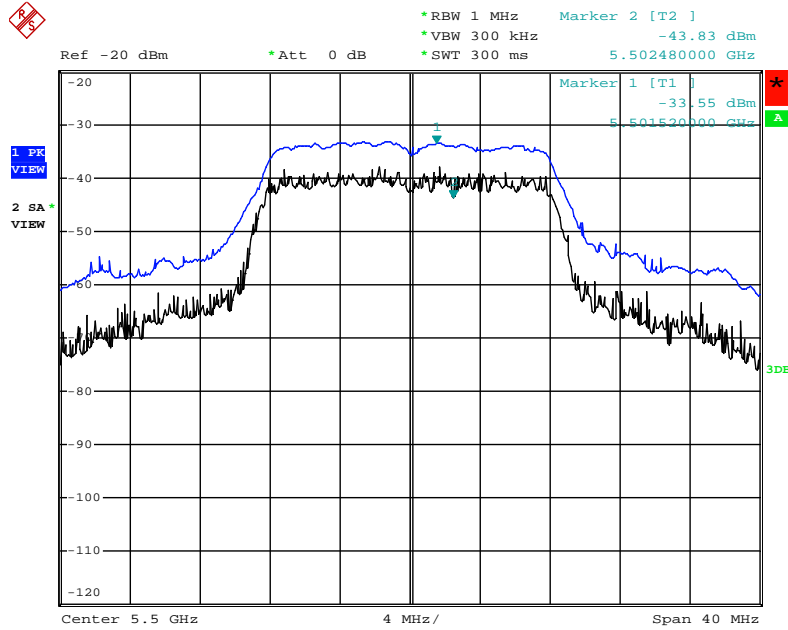

Date: 18.DEC.2011 19:17:06

4.7. Radiated Emissions Measurement for Transmitter and Receiver Spurious

4.7.1. Summary of Test Result

MAC Address: 00:15:00:85:80:1C DRTU Tool Version: 1.5.2-0308 Driver version: 14.0.4.115

Test #	Mode	Channel	Target Power (dBm)	Measured Power (dBm)	Test Performed	Limit	Result
First set of measurements - center channel in each band to determine which mode has the highest emissions. SISO modes evaluated at the same per chain power as the highest single chain power to cover both MIMO & SISO operation.							
1	n20 Chain A+B	#36 5180 MHz	A: 16.5 B: 16.5	A: 16.68 B: 16.44	Radiated Emissions, 1 - 40 GHz	FCC 15.209, 15 E	41.39dB μ V/m, -12.61dB
2		#40 5200 MHz	A: 16.5 B: 16.5	A: 16.61 B: 16.58			40.04dB μ V/m, -13.96dB
3		#48 5240 MHz	A: 16.5 B: 16.5	A: 16.64 B: 16.53			41.95dB μ V/m, -12.05dB
4		#52 5260 MHz	A: 16.5 B: 16.5	A: 16.67 B: 16.51			42.40dB μ V/m, -11.60dB
5		#60 5300 MHz	A: 16.5 B: 16.5	A: 16.58 B: 16.45			44.10dB μ V/m, -9.90dB
6		#64 5320 MHz	A: 16.5 B: 16.5	A: 16.5 B: 16.41			44.89dB μ V/m, -9.11dB
7		#100 5500 MHz	A: 16.5 B: 16.5	A: 16.39 B: 16.41			39.49dB μ V/m, -14.51dB
8		#118 5580 MHz	A: 16.5 B: 16.5	A: 16.54 B: 16.57			41.19dB μ V/m, -12.81dB
9		#140 5700 MHz	A: 16.5 B: 16.5	A: 16.59 B: 16.52			42.57dB μ V/m, -11.43dB
1	n40 Chain A+B	#46 5230 MHz	A: 16.5 B: 16.5	A: 16.62 B: 16.59			39.74dB μ V/m, -14.26dB
2		#62 5310 MHz	A: 16.5 B: 16.5	A: 16.52 B: 16.56			42.35dB μ V/m, -11.65dB
3		#110 5550 MHz	A: 16.5 B: 16.5	A: 16.64 B: 16.52			40.31dB μ V/m, -13.69dB
1	11a Chain A	#40 5200 MHz	16.5	16.46			39.00dB μ V/m, -15.00dB
2		#60 5300 MHz	16.5	16.41			40.59dB μ V/m, -13.41dB
3		#116 5580 MHz	16.5	16.53			37.92dB μ V/m, -16.08dB
1	11a Chain B	#40 5200 MHz	16.5	16.65			39.94dB μ V/m, -14.06dB
2		#60 5300 MHz	16.5	16.58			41.90dB μ V/m, -12.10dB
3		#116 5580 MHz	16.5	16.5			38.32dB μ V/m, -15.68dB
Final measurements based on center channel measurements in each band. 802.11n 20MHz mode was worst case in the 5150-5250 and 5250-5350 MHz bands.							



Test #	Mode	Channel	Target Power (dBm)	Measured Power (dBm)	Test Performed	Limit	Result
Receiver spurious measurements for the 5.7GHz band indicated that there were no significant differences in emissions between Chain B and Chain A + B and emissions on Chain A were lower than both Chain B and Chain A+B. Measurements were made with both chains active and only repeated on the individual chains for frequencies where the margin was less than 10dB.							
1	receive mode Chain A+B	#40 5200 MHz	-	-	Radiated Emissions, 1 - 18 GHz	RSS 210	43.45dB μ V/m / -10.55dB
2		#60 5300 MHz	-	-			42.24dB μ V/m / -11.76dB
3		#120 5600 MHz	-	-			43.24dB μ V/m / -10.76dB
1	receive mode Chain A	#40 5200 MHz	-	-			43.34dB μ V/m / -10.66dB
2		#60 5300 MHz	-	-			43.40dB μ V/m / -10.60dB
3		#120 5600 MHz	-	-			42.27dB μ V/m / -11.73dB
1	receive mode Chain B	#40 5200 MHz	-	-			41.14dB μ V/m / -12.86dB
2		#60 5300 MHz	-	-			42.40dB μ V/m / -11.60dB
3		#120 5600 MHz	-	-			42.87dB μ V/m / -11.13dB

4.7.2. Limit

For transmitters operating in the 5.15-5.35 GHz band: all emissions outside of the 5.15-5.35 GHz band shall not exceed an EIRP of -27 dBm/MHz (68.3dBuV/m at 3m). For transmitters operating in the 5.470-5.725 GHz band: all emissions outside of the 5.470-5.725 GHz band shall not exceed an EIRP of -27 dBm/MHz (68.3dBuV/m at 3m). For transmitters operating in the 5.725-5.825 GHz band: all emissions within the frequency range from the band edge to 10 MHz above or below the band edge shall not exceed an EIRP of -17 dBm/MHz (78.3dBuV/m at 3m); for frequencies 10 MHz or greater above or below the band edge, emissions shall not exceed an EIRP of -27 dBm/MHz (68.3dBuV/m at 3m). In addition, In case the emission fall within the restricted band specified on 15.205(a), then the 15.209(a) limit in the table below has to be followed.

Frequencies (MHz)	Field Strength (micorvolts/meter)	Measurement Distance (meters)
0.009~0.490	2400/F(KHz)	300
0.490~1.705	24000/F(KHz)	30
1.705~30.0	30	30
30~88	100	3
88~216	150	3
216~960	200	3
Above 960	500	3

4.7.3. Measuring Instruments and Setting

Please refer to section 5 of equipments list in this report. The following table is the setting of spectrum analyzer and receiver.

Spectrum Parameter	Setting
Attenuation	Auto
Start Frequency	1000 MHz
Stop Frequency	40 GHz
RB / VB (Emission in restricted band)	1MHz / 1MHz for Peak, 1 MHz / 10Hz for Average
RB / VB (Emission in non-restricted band)	1000KHz / 1000KHz for peak

Receiver Parameter	Setting
Attenuation	Auto
Start ~ Stop Frequency	9kHz~150kHz / RB 200Hz for QP
Start ~ Stop Frequency	150kHz~30MHz / RB 9kHz for QP
Start ~ Stop Frequency	30MHz~1000MHz / RB 120kHz for QP

4.7.4. Test Procedures

1. Configure the EUT according to ANSI C63.10. The EUT was placed on the top of the turntable 0.8 meter above ground. The phase center of the receiving antenna mounted on the top of a height-variable antenna tower was placed 3 meters far away from the turntable.
2. Power on the EUT and all the supporting units. The turntable was rotated by 360 degrees to determine the position of the highest radiation.
3. The height of the broadband receiving antenna was varied between one meter and four meters above ground to find the maximum emissions field strength of both horizontal and vertical polarization.
4. For each suspected emissions, the antenna tower was scan (from 1 M to 4 M) and then the turntable was rotated (from 0 degree to 360 degrees) to find the maximum reading.
5. Set the test-receiver system to Peak or CISPR quasi-peak Detect Function with specified bandwidth under Maximum Hold Mode.
6. For emissions above 1GHz, use 1MHz VBW and RBW for peak reading. Then 1MHz RBW and 10Hz VBW for average reading in spectrum analyzer.
7. When the radiated emissions limits are expressed in terms of the average value of the emissions, and pulsed operation is employed, the measurement field strength shall be determined by averaging over one complete pulse train, including blanking intervals, as long as the pulse train does not exceed 0.1 seconds. As an alternative (provided the transmitter operates for longer than 0.1 seconds) or in cases where the pulse train exceeds 0.1 seconds, the measured field strength shall be determined from the average absolute voltage during a 0.1 second interval during which the field strength is at its maximum value.

8. If the emissions level of the EUT in peak mode was 3 dB lower than the average limit specified, then testing will be stopped and peak values of EUT will be reported, otherwise, the emissions which do not have 3 dB margin will be repeated one by one using the quasi-peak method for below 1GHz.
9. For testing above 1GHz, the emissions level of the EUT in peak mode was lower than average limit (that means the emissions level in peak mode also complies with the limit in average mode), then testing will be stopped and peak values of EUT will be reported, otherwise, the emissions will be measured in average mode again and reported.
10. In case the emission is lower than 30MHz, loop antenna has to be used for measurement and the recorded data should be QP measured by receiver. High – Low scan is not required in this case.

4.7.5. Test Setup Layout

For radiated emissions below 1GHz

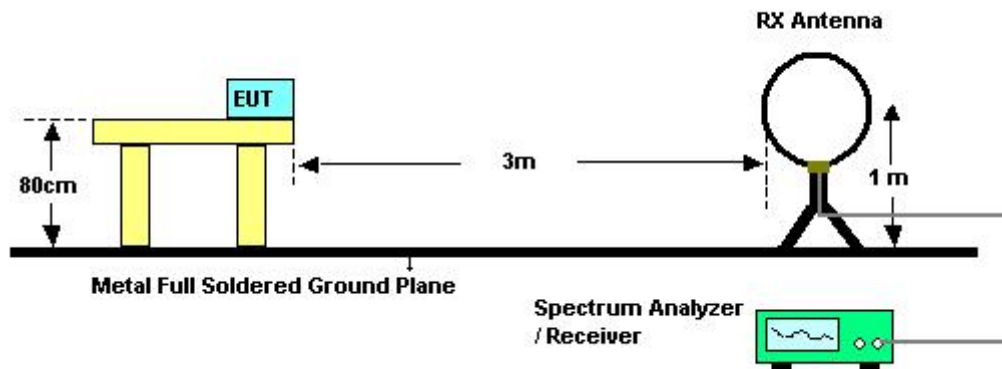

For radiated emissions above 1GHz

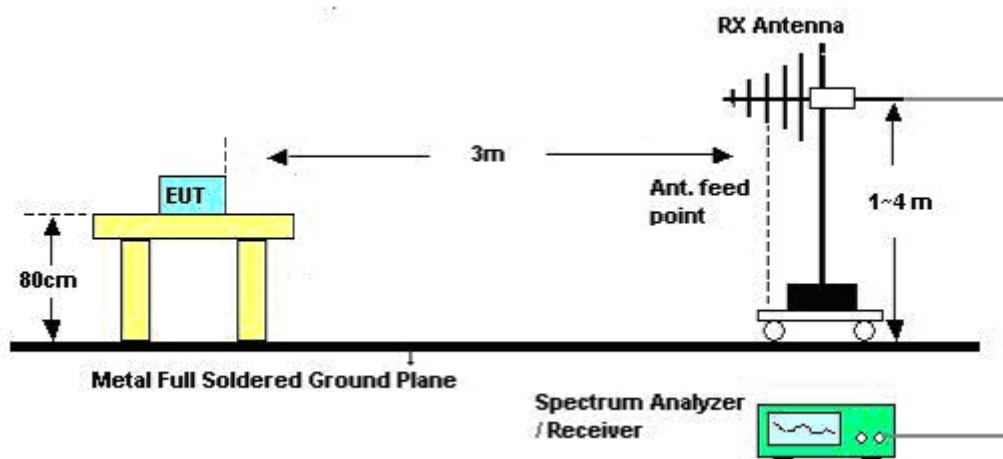

4.7.6. Test Deviation

There is no deviation with the original standard.

4.7.7. EUT Operation during Test

The EUT was programmed to be in continuously transmitting mode.

4.7.8. Results of Radiated Emissions (9kHz~30MHz)

Temperature	22°C	Humidity	63%
Test Engineer	Denis Su	Configurations	CTX
Test Date	Dec. 16, 2011		

Freq. (MHz)	Level (dBuV)	Over Limit (dB)	Limit Line (dBuV)	Remark
-	-	-	-	See Note

Note:

The amplitude of spurious emissions that are attenuated by more than 20dB below the permissible value has no need to be reported.

Distance extrapolation factor = $40 \log(\text{specific distance} / \text{test distance})$ (dB);

Limit line = specific limits (dBuV) + distance extrapolation factor.

4.7.9. Results of Radiated Emissions (30MHz~1GHz)

Temperature	22°C	Humidity	63%
Test Engineer	Denis Su	Configurations	CTX

Horizontal

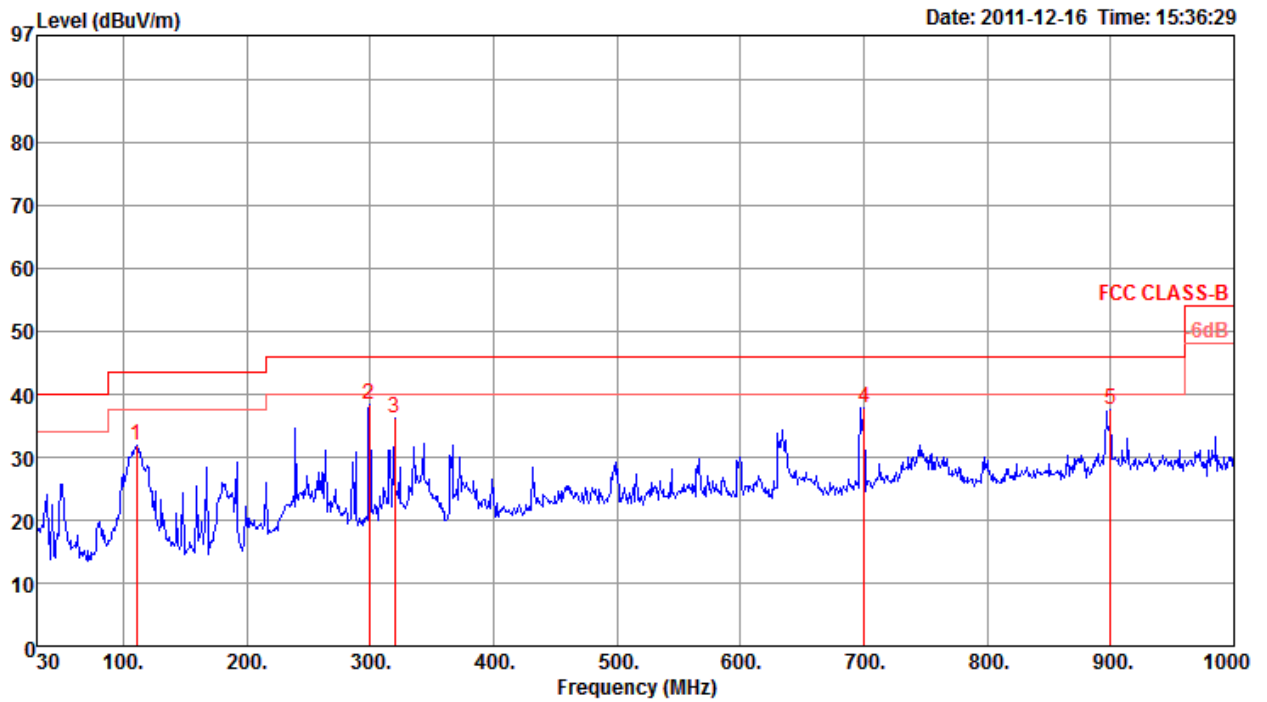

	Freq	Level	Limit	Over	Read	Cable	Preamp	Antenna	T/Pos	A/Pos	Remark	Pol/Phase
	MHz	dBuV/m	dBuV/m	dB	dBuV	dB	dB	dB/m	deg	cm		
1	110.51	31.76	43.50	-11.74	45.34	1.57	27.55	12.40	0	400	Peak	HORIZONTAL
2	299.66	38.41	46.00	-7.59	49.22	2.51	26.90	13.58	0	400	Peak	HORIZONTAL
3	320.03	36.24	46.00	-9.76	46.29	2.63	27.03	14.35	0	400	Peak	HORIZONTAL
4	700.27	37.80	46.00	-8.20	41.67	4.16	27.99	19.96	0	400	Peak	HORIZONTAL
5	900.09	37.66	46.00	-8.34	39.43	4.60	27.40	21.03	0	400	Peak	HORIZONTAL

Vertical

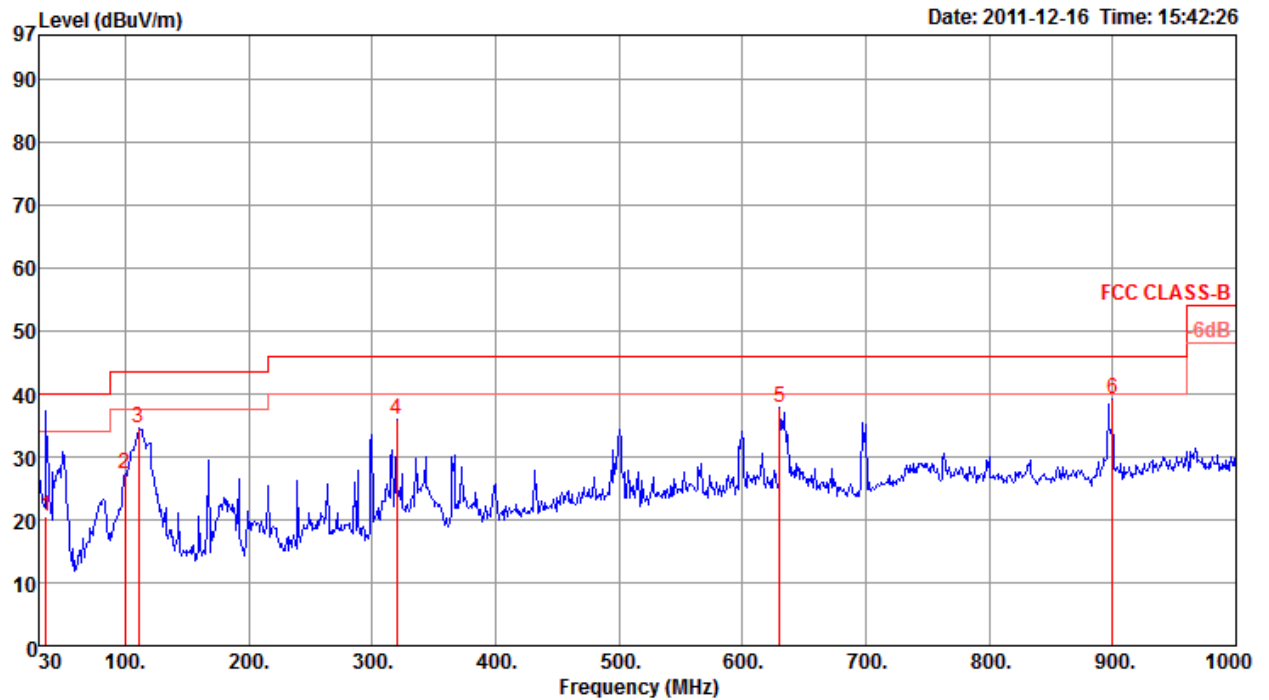

	Freq	Level	Limit	Over	Read	Cable	Preamp	Antenna	T/Pos	A/Pos	Remark	Pol/Phase
	MHz	dBuV/m	dBuV/m	dB	dBuV	dB	dB	dB/m	deg	cm		
1 q	35.85	20.51	40.00	-19.49	32.50	0.93	27.80	14.88	126	100	QP	VERTICAL
2	99.84	27.31	43.50	-16.19	42.53	1.50	27.60	10.88	0	100	Peak	VERTICAL
3	110.51	34.49	43.50	-9.01	48.07	1.57	27.55	12.40	0	100	Peak	VERTICAL
4	320.03	36.02	46.00	-9.98	46.07	2.63	27.03	14.35	0	100	Peak	VERTICAL
5	630.43	37.74	46.00	-8.26	42.30	3.83	28.07	19.68	0	100	Peak	VERTICAL
6 p	900.09	39.30	46.00	-6.70	41.07	4.60	27.40	21.03	0	100	Peak	VERTICAL

Note:

The amplitude of spurious emissions that are attenuated by more than 20dB below the permissible value has no need to be reported.

Emission level (dBuV/m) = 20 log Emission level (uV/m).

Corrected Reading: Antenna Factor + Cable Loss + Read Level - Preamp Factor = Level.

4.7.10. Results for Radiated Emissions (1GHz~40GHz)

Radiated Spurious Emissions - 802.11a, Chain A

Date of Test:	Dec. 15, 2011
Test Engineer:	Robert Chang

Test #1 EUT on Channel-40 5200MHz - 802.11b, Chain A

Antenna Port	Target (dBm)	Power Settings Measured (dBm)	Software Setting
Chain A	16.5	16.46	20

Frequency MHz	Level dBuV/m	Test Polar V/H	15.209/15.407		Detector PK/AV	Azimuth degrees	Height meters	Comments
			Limit	Margin				
15600.4	53.24	V	74	-20.76	Peak	205	1.26	RB/VB:1MHz/3MHz
15599.08	39.00	V	54	-15.00	Avg	205	1.26	RB/VB:1MHz/10Hz
15600.43	50.78	H	74	-23.22	Peak	142	1	RB/VB:1MHz/3MHz
1559.48	36.71	H	54	-17.29	Avg	142	1	RB/VB:1MHz/10Hz

Test #2 EUT on Channel-60 5300MHz- 802.11a, Chain A

Antenna Port	Target (dBm)	Power Settings Measured (dBm)	Software Setting
Chain A	16.5	16.41	21

Frequency MHz	Level dBuV/m	Test Polar V/H	15.209/15.407		Detector PK/AV	Azimuth degrees	Height meters	Comments
			Limit	Margin				
15900.33	55.96	V	74	-18.04	Peak	184	1	RB/VB:1MHz/3MHz
15899.12	40.59	V	54	-13.41	Avg	184	1	RB/VB:1MHz/10Hz
15900.13	53.05	H	74	-20.95	Peak	170	1.35	RB/VB:1MHz/3MHz
15900.33	38.26	H	54	-15.74	Avg	170	1.35	RB/VB:1MHz/10Hz



Test #3 EUT on Channel-116 5580MHz- 802.11a, Chain A

Antenna Port	Target (dBm)	Power Settings Measured (dBm)	Software Setting
Chain A	16.5	16.53	23.5

Frequency	Level	Test Polar	15.209/15.407		Detector	Azimuth	Height	Comments
MHz	dBuV/m	V/H	Limit	Margin	PK/AV	degrees	meters	
11159.91	53.19	V	74	-20.81	Peak	270	1	RB/VB:1MHz/3MHz
11159.98	37.92	V	54	-16.08	Avg	270	1	RB/VB:1MHz/10Hz
11159.54	50.97	H	74	-23.03	Peak	139	1	RB/VB:1MHz/3MHz
11159.95	36.67	H	54	-17.33	Avg	139	1	RB/VB:1MHz/10Hz



Radiated Spurious Emissions - 802.11a, Chain B

Date of Test:	Dec. 15, 2011
Test Engineer:	Robert Chang

Test #1 EUT on Channel-40 5200MHz - 802.11b, Chain B

Antenna Port	Target (dBm)	Power Settings Measured (dBm)	Software Setting
Chain B	16.5	16.65	22

Frequency MHz	Level dBuV/m	Test Polar V/H	15.209/15.407		Detector PK/AV	Azimuth degrees	Height meters	Comments
			Limit	Margin				
15599.42	52.01	V	74	-21.99	Peak	174	1	RB/VB:1MHz/3MHz
15599.02	37.66	V	54	-16.34	Avg	174	1	RB/VB:1MHz/10Hz
15599.71	54.76	H	74	-19.24	Peak	192	1.27	RB/VB:1MHz/3MHz
15599.24	39.94	H	54	-14.06	Avg	192	1.27	RB/VB:1MHz/10Hz

Test #2 EUT on Channel-60 5300MHz- 802.11a, Chain B

Antenna Port	Target (dBm)	Power Settings Measured (dBm)	Software Setting
Chain B	16.5	16.58	22

Frequency MHz	Level dBuV/m	Test Polar V/H	15.209/15.247		Detector PK/AV	Azimuth degrees	Height meters	Comments
			Limit	Margin				
15900.39	35.46	V	74	-38.54	Peak	48	1	RB/VB:1MHz/3MHz
15899.56	41.90	V	54	-12.10	Avg	48	1	RB/VB:1MHz/10Hz
15900.75	54.30	H	74	-19.70	Peak	189	1	RB/VB:1MHz/3MHz
15899.11	39.24	H	54	-14.76	Avg	189	1	RB/VB:1MHz/10Hz

**Test #3 EUT on Channel-116 5580MHz- 802.11a, Chain B**

Antenna Port	Target (dBm)	Power Settings Measured (dBm)	Software Setting
Chain B	16.5	16.5	24.5

Frequency	Level	Test Polar	15.209/15.247		Detector	Azimuth	Height	Comments
MHz	dBuV/m	V/H	Limit	Margin	PK/AV	degrees	meters	
11159.51	51.73	V	74	-22.27	Peak	143	1.24	RB/VB:1MHz/3MHz
11160.1	38.32	V	54	-15.68	Avg	143	1.24	RB/VB:1MHz/10Hz
11159.62	50.18	H	74	-23.82	Peak	278	1	RB/VB:1MHz/3MHz
11160.08	36.49	H	54	-17.51	Avg	278	1	RB/VB:1MHz/10Hz



Radiated Spurious Emissions - 802.11an 20MHz, Chain A+B (Worse Case)

Date of Test:	Dec. 15, 2011
Test Engineer:	Robert Chang

Test #1 EUT on Channel-36 5180MHz - 802.11an 20MHz, Chain A+B

Chain	Target (dBm)			Power Settings Measured (dBm)			Software Setting	
	A	B	Total	A	B	Total		
	16.5	16.5	19.51	16.68	16.44	19.57	26	25.5

Frequency	Level	Test Polar	15.209/15.407		Detector	Azimuth	Height	Comments
MHz	dBuV/m	V/H	Limit	Margin	PK/AV	degrees	meters	
15540.19	55.27	V	74	-18.73	Peak	192	1.01	RB/VB:1MHz/3MHz
15539.04	41.39	V	54	-12.61	Avg	192	1.01	RB/VB:1MHz/10Hz
15540.83	52.47	H	74	-21.53	Peak	182	1	RB/VB:1MHz/3MHz
15539.34	37.90	H	54	-16.10	Avg	182	1	RB/VB:1MHz/10Hz

Test #2 EUT on Channel-40 5200MHz-802.11an 20MHz, Chain A+B (Worse Case)

Chain	Target (dBm)			Power Settings Measured (dBm)			Software Setting	
	A	B	Total	A	B	Total		
	16.5	16.5	19.51	16.61	16.58	19.61	26	26

Frequency	Level	Test Polar	15.209/15.407		Detector	Azimuth	Height	Comments
MHz	dBuV/m	V/H	Limit	Margin	PK/AV	degrees	meters	
15600.97	54.72	V	74	-19.28	Peak	185	1	RB/VB:1MHz/3MHz
15599.06	40.04	V	54	-13.96	Avg	185	1	RB/VB:1MHz/10Hz
15599.84	52.06	H	74	-21.94	Peak	165	1	RB/VB:1MHz/3MHz
15599.25	37.78	H	54	-16.22	Avg	165	1	RB/VB:1MHz/10Hz

Test #3 EUT on Channel-48 5240MHz- 802.11an 20MHz, Chain A+B

Chain	Target (dBm)			Power Settings Measured (dBm)			Software Setting	
	A	B	Total	A	B	Total		
	16.5	16.5	19.51	16.46	16.53	19.51	26	26

Frequency	Level	Test Polar	15.209/15.407		Detector	Azimuth	Height	Comments
MHz	dBuV/m	V/H	Limit	Margin	PK/AV	degrees	meters	
15719.6	52.78	V	74	-21.22	Peak	161	1.58	RB/VB:1MHz/3MHz
15719.56	38.69	V	54	-15.31	Avg	161	1.58	RB/VB:1MHz/10Hz
15719.55	56.16	H	74	-17.84	Peak	212	1.2	RB/VB:1MHz/3MHz
15721	41.95	H	54	-12.05	Avg	212	1.2	RB/VB:1MHz/10Hz

Test #4 EUT on Channel-52 5260MHz- 802.11an 20MHz, Chain A+B

Chain	Target (dBm)			Power Settings Measured (dBm)			Software Setting	
	A	B	Total	A	B	Total		
	16.5	16.5	19.51	16.67	16.51	19.60	26.5	26

Frequency	Level	Test Polar	15.209/15.407		Detector	Azimuth	Height	Comments
MHz	dBuV/m	V/H	Limit	Margin	PK/AV	degrees	meters	
15779.76	56.80	V	74	-17.20	Peak	188	1	RB/VB:1MHz/3MHz
15780.99	42.40	V	54	-11.60	Avg	188	1	RB/VB:1MHz/10Hz
15780.68	53.07	H	74	-20.93	Peak	162	1.28	RB/VB:1MHz/3MHz
15781	38.67	H	54	-15.33	Avg	162	1.28	RB/VB:1MHz/10Hz

Test #5 EUT on Channel-60 5300MHz- 802.11an 20MHz, Chain A+B(Worse Case)

Chain	Target (dBm)			Power Settings Measured (dBm)			Software Setting	
	A	B	Total	A	B	Total		
	16.5	16.5	19.51	16.58	16.45	19.53	26.5	26

Frequency	Level	Test Polar	15.209/15.407		Detector	Azimuth	Height	Comments
MHz	dBuV/m	V/H	Limit	Margin	PK/AV	degrees	meters	
15900.35	57.98	V	74	-16.02	Peak	182	1	RB/VB:1MHz/3MHz
15900.91	44.10	V	54	-9.90	Avg	182	1	RB/VB:1MHz/10Hz
15900.14	54.07	H	74	-19.93	Peak	173	1.37	RB/VB:1MHz/3MHz
15900.42	39.95	H	54	-14.05	Avg	173	1.37	RB/VB:1MHz/10Hz

Test #6 EUT on Channel-64 5320MHz- 802.11an 20MHz, Chain A+B

Chain	Target (dBm)			Power Settings Measured (dBm)			Software Setting	
	A	B	Total	A	B	Total		
	16.5	16.5	19.51	16.5	16.41	19.47	26.5	26

Frequency	Level	Test Polar	15.209/15.407		Detector	Azimuth	Height	Comments
MHz	dBuV/m	V/H	Limit	Margin	PK/AV	degrees	meters	
15959.98	58.65	V	74	-15.35	Peak	173	1	RB/VB:1MHz/3MHz
15960.94	44.89	V	54	-9.11	Avg	173	1	RB/VB:1MHz/10Hz
15959.01	54.61	H	74	-19.39	Peak	170	137	RB/VB:1MHz/3MHz
15960.14	40.06	H	54	-13.94	Avg	170	137	RB/VB:1MHz/10Hz

Test #7 EUT on Channel-100 5500MHz- 802.11an 20MHz, Chain A+B

Chain	Target (dBm)			Power Settings Measured (dBm)			Software Setting	
	A	B	Total	A	B	Total		
	16.5	16.5	19.51	16.39	16.41	19.41	27.5	27

Frequency	Level	Test Polar	15.209/15.407		Detector	Azimuth	Height	Comments
MHz	dBuV/m	V/H	Limit	Margin	PK/AV	degrees	meters	
10999.81	53.04	V	74	-20.96	Peak	271	167	RB/VB:1MHz/3MHz
10999.97	39.49	V	54	-14.51	Avg	271	167	RB/VB:1MHz/10Hz
11000.07	50.46	H	74	-23.54	Peak	179	164	RB/VB:1MHz/3MHz
10999.99	36.81	H	54	-17.19	Avg	179	164	RB/VB:1MHz/10Hz

Test #8 EUT on Channel-118 5580MHz- 802.11an 20MHz, Chain A+B(Worse Case)

Chain	Target (dBm)			Power Settings Measured (dBm)			Software Setting	
	A	B	Total	A	B	Total		
	16.5	16.5	19.51	16.54	16.57	19.57	27.5	28

Frequency	Level	Test Polar	15.209/15.407		Detector	Azimuth	Height	Comments
MHz	dBuV/m	V/H	Limit	Margin	PK/AV	degrees	meters	
11160.01	54.98	V	74	-19.02	Peak	273	1	RB/VB:1MHz/3MHz
11159.96	41.19	V	54	-12.81	Avg	273	1	RB/VB:1MHz/10Hz
11159.86	51.69	H	74	-22.31	Peak	107	1	RB/VB:1MHz/3MHz
11159.5	38.32	H	54	-15.68	Avg	107	1	RB/VB:1MHz/10Hz



Test #9 EUT on Channel-140MHz- 802.11an 20MHz, Chain A+B

Chain	Target (dBm)			Power Settings Measured (dBm)			Software Setting	
	A	B	Total	A	B	Total		
	16.5	16.5	19.51	16.59	16.52	19.57	30.5	30

Frequency	Level	Test Polar	15.209/15.407		Detector	Azimuth	Height	Comments
MHz	dBuV/m	V/H	Limit	Margin	PK/AV	degrees	meters	
11400.1	57.51	V	74	-16.49	Peak	266	1.55	RB/VB:1MHz/3MHz
11399.54	42.57	V	54	-11.43	Avg	266	1.55	RB/VB:1MHz/10Hz
11400.35	52.82	H	74	-21.18	Peak	171	108	RB/VB:1MHz/3MHz
11399.91	37.93	H	54	-16.07	Avg	171	108	RB/VB:1MHz/10Hz

Radiated Spurious Emissions - 802.11n 40MHz, Chain A+B

Date of Test:	Dec. 15, 2011
Test Engineer:	Robert Chang

Test #1 EUT on Channel-46 5230MHz - 802.11n 40MHz, Chain A+B

Chain	Target (dBm)			Power Settings Measured (dBm)			Software Setting	
	A	B	Total	A	B	Total		
	16.5	16.5	19.51	16.62	16.59	19.62	27	27.5

Frequency	Level	Test Polar	15.209/15.407		Detector	Azimuth	Height	Comments
MHz	dBuV/m	V/H	Limit	Margin	PK/AV	degrees	meters	
15689.59	53.56	V	74	-20.44	Peak	214	1	RB/VB:1MHz/3MHz
15689.08	39.74	V	54	-14.26	Avg	214	1	RB/VB:1MHz/10Hz
15690.89	52.42	H	74	-21.58	Peak	182	1	RB/VB:1MHz/3MHz
15690.55	37.78	H	54	-16.22	Avg	182	1	RB/VB:1MHz/10Hz

Test #2 EUT on Channel-62 5310MHz- 802.11n 40MHz, Chain A+B

Chain	Target (dBm)			Power Settings Measured (dBm)			Software Setting	
	A	B	Total	A	B	Total		
	16.5	16.5	19.51	16.52	16.56	19.55	27.5	27.5

Frequency	Level	Test Polar	15.209/15.407		Detector	Azimuth	Height	Comments
MHz	dBuV/m	V/H	Limit	Margin	PK/AV	degrees	meters	
15930.7	56.89	V	74	-17.11	Peak	208	1.22	RB/VB:1MHz/3MHz
15931	42.35	V	54	-11.65	Avg	208	1.22	RB/VB:1MHz/10Hz
15929.37	53.28	H	74	-20.72	Peak	189	1.04	RB/VB:1MHz/3MHz
15929.1	38.71	H	54	-15.29	Avg	189	1.04	RB/VB:1MHz/10Hz



Test #3 EUT on Channel-110 5550MHz- 802.11n 40MHz, Chain A+B

Chain	Target (dBm)			Power Settings Measured (dBm)			Software Setting	
	A	B	Total	A	B	Total		
	16.5	16.5	19.51	16.64	16.52	19.59	29	28.5

Frequency	Level	Test Polar	15.209/15.407		Detector	Azimuth	Height	Comments
MHz	dBuV/m	V/H	Limit	Margin	PK/AV	degrees	meters	
11180.21	56.84	V	74	-17.16	Peak	270	1.88	RB/VB:1MHz/3MHz
11180.01	40.31	V	54	-13.69	Avg	270	1.88	RB/VB:1MHz/10Hz
11180.06	49.67	H	74	-24.33	Peak	213	1	RB/VB:1MHz/3MHz
11180.33	35.70	H	54	-18.30	Avg	213	1	RB/VB:1MHz/10Hz



Radiated Receiver Spurious Emissions - 802.11a

Date of Test:	Dec. 15, 2011
Test Engineer:	Robert Chang

Test #1 EUT on Channel-40 5200MHz - Chain A

Frequency	Level	Test Polar	15.209/15.407		Detector	Azimuth	Height	Comments
			Limit	Margin				
MHz	dBuV/m	V/H			PK/AV	degrees	meters	
1166.74	50.04	V	74	-23.96	Peak	276	1	RB/VB:1MHz/3MHz
1166.77	43.34	V	54	-10.66	Avg	276	1	RB/VB:1MHz/10Hz
1166.66	42.03	H	74	-31.97	Peak	235	1	RB/VB:1MHz/3MHz
1166.76	33.68	H	54	-20.32	Avg	235	1	RB/VB:1MHz/10Hz

Test #2 EUT on Channel-60 5300MHz- Chain A

Frequency	Level	Test Polar	15.209/15.407		Detector	Azimuth	Height	Comments
			Limit	Margin				
MHz	dBuV/m	V/H			PK/AV	degrees	meters	
1166.44	50.14	V	74	-23.86	Peak	251	1	RB/VB:1MHz/3MHz
1165.97	43.40	V	54	-10.60	Avg	251	1	RB/VB:1MHz/10Hz
1166.16	43.03	H	74	-30.97	Peak	247	1	RB/VB:1MHz/3MHz
1165.76	33.18	H	54	-20.82	Avg	247	1	RB/VB:1MHz/10Hz

Test #3 EUT on Channel-120 5600MHz - Chain A

Frequency	Level	Test Polar	15.209/15.407		Detector	Azimuth	Height	Comments
			Limit	Margin				
MHz	dBuV/m	V/H			PK/AV	degrees	meters	
1166.79	50.31	V	74	-23.69	Peak	275	1	RB/VB:1MHz/3MHz
1166.86	42.27	V	54	-11.73	Avg	275	1	RB/VB:1MHz/10Hz
1167.28	41.78	H	74	-32.22	Peak	141	1	RB/VB:1MHz/3MHz
1166.79	33.50	H	54	-20.50	Avg	141	1	RB/VB:1MHz/10Hz



Radiated Receiver Spurious Emissions - 802.11a

Date of Test:	Dec. 15, 2011
Test Engineer:	Robert Chang

Test #1 EUT on Channel-40 5200MHz - Chain B

Frequency	Level	Test Polar	15.209/15.407		Detector	Azimuth	Height	Comments
			Limit	Margin				
MHz	dBuV/m	V/H			PK/AV	degrees	meters	
1166.74	50.34	V	74	-23.66	Peak	269	1	RB/VB:1MHz/3MHz
1166.77	41.14	V	54	-12.86	Avg	269	1	RB/VB:1MHz/10Hz
1166.66	42.04	H	74	-31.96	Peak	144	1	RB/VB:1MHz/3MHz
1166.76	33.48	H	54	-20.52	Avg	144	1	RB/VB:1MHz/10Hz

Test #2 EUT on Channel-60 5300MHz- Chain B

Frequency	Level	Test Polar	15.209/15.407		Detector	Azimuth	Height	Comments
			Limit	Margin				
MHz	dBuV/m	V/H			PK/AV	degrees	meters	
1166.44	50.14	V	74	-23.86	Peak	266	1	RB/VB:1MHz/3MHz
1165.97	42.40	V	54	-11.60	Avg	266	1	RB/VB:1MHz/10Hz
1166.16	42.64	H	74	-31.36	Peak	154	1	RB/VB:1MHz/3MHz
1165.76	33.04	H	54	-20.96	Avg	154	1	RB/VB:1MHz/10Hz

Test #3 EUT on Channel-120 5600MHz - Chain B

Frequency	Level	Test Polar	15.209/15.407		Detector	Azimuth	Height	Comments
			Limit	Margin				
MHz	dBuV/m	V/H			PK/AV	degrees	meters	
1166.79	51.05	V	74	-22.95	Peak	267	1	RB/VB:1MHz/3MHz
1166.86	42.87	V	54	-11.13	Avg	267	1	RB/VB:1MHz/10Hz
1167.28	42.80	H	74	-31.20	Peak	139	1	RB/VB:1MHz/3MHz
1166.79	32.90	H	54	-21.10	Avg	139	1	RB/VB:1MHz/10Hz



Radiated Receiver Spurious Emissions - 802.11a

Date of Test:	Dec.15, 2011
Test Engineer:	Robert Chang

Test #1 EUT on Channel-40 5200MHz - ChainA+B

Frequency	Level	Test Polar	15.209/15.407		Detector	Azimuth	Height	Comments
			Limit	Margin				
MHz	dBuV/m	V/H			PK/AV	degrees	meters	
1166.79	50.61	V	74	-23.39	Peak	243	1	RB/VB:1MHz/3MHz
1165.96	43.45	V	54	-10.55	Avg	243	1	RB/VB:1MHz/10Hz
1167.28	43.55	H	74	-30.45	Peak	173	1	RB/VB:1MHz/3MHz
1166.79	30.60	H	54	-23.40	Avg	173	1	RB/VB:1MHz/10Hz

Test #2 EUT on Channel-60 5300MHz- ChainA+B

Frequency	Level	Test Polar	15.209/15.407		Detector	Azimuth	Height	Comments
			Limit	Margin				
MHz	dBuV/m	V/H			PK/AV	degrees	meters	
1166.63	51.00	V	74	-23.00	Peak	255	1	RB/VB:1MHz/3MHz
1166.13	42.24	V	54	-11.76	Avg	255	1	RB/VB:1MHz/10Hz
1166.16	42.53	H	74	-31.47	Peak	167	1	RB/VB:1MHz/3MHz
1166.84	33.41	H	54	-20.59	Avg	167	1	RB/VB:1MHz/10Hz

Test #3 EUT on Channel-120 5600MHz - ChainA+B

Frequency	Level	Test Polar	15.209/15.407		Detector	Azimuth	Height	Comments
			Limit	Margin				
MHz	dBuV/m	V/H			PK/AV	degrees	meters	
1166.63	49.94	V	74	-24.06	Peak	268	1	RB/VB:1MHz/3MHz
1166.83	43.24	V	54	-10.76	Avg	268	1	RB/VB:1MHz/10Hz
1166.66	42.83	H	74	-31.17	Peak	147	1	RB/VB:1MHz/3MHz
1166.84	34.33	H	54	-19.67	Avg	147	1	RB/VB:1MHz/10Hz

4.8. Frequency Stability Measurement

4.8.1. Limit

Manufacturers of U-NII devices are responsible for ensuring frequency stability such that an emissions is maintained within the band of operation under all conditions of normal operation as specified in the user's manual or $\pm 20\text{ppm}$ (IEEE 802.11 specification).

4.8.2. Measuring Instruments and Setting

Please refer to section 5 of equipments list in this report. The following table is the setting of the spectrum analyzer.

Spectrum Parameter	Setting
Attenuation	Auto
Span Frequency	Entire absence of modulation emissions bandwidth
RB	10 kHz
VB	10 kHz
Sweep Time	Auto

4.8.3. Test Procedures

1. The transmitter output (antenna port) was connected to the spectrum analyzer.
2. EUT have transmitted absence of modulation signal and fixed channelize.
3. Set the spectrum analyzer span to view the entire absence of modulation emissions bandwidth.
4. Set RBW = 10 kHz, VBW = 10 kHz with peak detector and maxhold settings.
5. f_c is declaring of channel frequency. Then the frequency error formula is $(f_c - f) / f_c \times 10^6$ ppm and the limit is less than $\pm 20\text{ppm}$ (IEEE 802.11 specification).
6. The test extreme voltage is to change the primary supply voltage from 85 to 115 percent of the nominal value
7. Extreme temperature rule is $-30^\circ\text{C} \sim 50^\circ\text{C}$.

4.8.4. Test Setup Layout

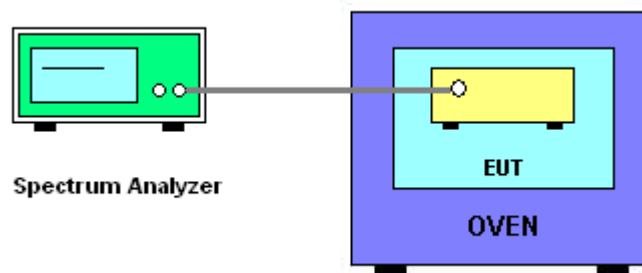

4.8.5. Test Deviation

There is no deviation with the original standard.

4.8.6. EUT Operation during Test

The EUT was programmed to be in continuously un-modulation transmitting mode.

4.8.7. Test Result of Frequency Stability

Voltage vs. Frequency Stability

Voltage	Measurement Frequency (MHz)	
	5200	5300
(V)		
126.50	5200.0185	5300.0250
110.00	5200.0158	5300.0158
93.50	5200.0100	5300.0100
Max. Deviation (MHz)	0.018500	0.025000
Max. Deviation (ppm)	3.56	4.72

Temperature vs. Frequency Stability

Temperature	Measurement Frequency (MHz)	
	5200	5300
(°C)		
-30	5200.0544	5300.0544
-20	5200.0540	5300.0544
-10	5200.0480	5300.0498
0	5200.0358	5300.0382
10	5200.0186	5300.0186
20	5200.0158	5300.0158
30	5200.0175	5300.0132
40	5200.0120	5300.0125
50	5200.0052	5300.0050
Max. Deviation (MHz)	0.054400	0.054400
Max. Deviation (ppm)	10.46	10.2642

4.9. Antenna Requirements

4.9.1. Limit

Except for special regulations, the Low-power Radio-frequency Devices must not be equipped with any jacket for installing an antenna with extension cable. An intentional radiator shall be designed to ensure that no antenna other than that furnished by the responsible party shall be used with the device. The use of a permanently attached antenna or of an antenna that uses a unique coupling to the intentional radiator shall be considered sufficient to comply with the provisions of this Section. The manufacturer may design the unit so that the user can replace a broken antenna, but the use of a standard antenna jack or electrical connector is prohibited. Further, this requirement does not apply to intentional radiators that must be professionally installed.

4.9.2. Antenna Connector Construction

Please refer to section 3.3 in this test report; antenna connector complied with the requirements.

5. LIST OF MEASURING EQUIPMENTS

Instrument	Manufacturer	Model No.	Serial No.	Characteristics	Calibration Date	Remark
EMI Test Receiver	R&S	ESCS 30	100377	9kHz ~ 2.75GHz	Sep. 14, 2011	Conduction (CO01-CB)
LISN	F.C.C.	FCC-LISN-50-16-2	04083	150kHz ~ 100MHz	Oct. 28, 2011	Conduction (CO01-CB)
V- LISN	Schwarzbeck	NSLK 8127	8127-478	9K ~ 30MHz	Nov. 16, 2011	Conduction (CO01-CB)
PULSE LIMITER	R&S	ESH3-Z2	100430	9K~30MHz	Jan. 04, 2011	Conduction (CO01-CB)
COND Cable	-	Cable	-	0.15MHz~30MHz	Dec. 04, 2011	Conduction (CO01-CB)
BILOG ANTENNA	Schaffner	CBL6112D	22021	20MHz ~ 2GHz	Oct. 29, 2011	Radiation (03CH01-CB)
Horn Antenna	EMCO	3115	00075790	750MHz~18GHz	Nov. 22, 2011	Radiation (03CH01-CB)
Horn Antenna	SCHWARZBEAK	BBHA 9170	BBHA9170252	15GHz ~ 40GHz	Nov. 22, 2011	Radiation (03CH01-CB)
Pre-Amplifier	Agilent	8447D	2944A10991	0.1MHz ~ 1.3GHz	Nov. 17, 2011	Radiation (03CH01-CB)
Pre-Amplifier	Agilent	8449B	3008A02310	1GHz ~ 26.5GHz	Nov. 23, 2011	Radiation (03CH01-CB)
Pre-Amplifier	WM	TF-130N-R1	923365	26.5GHz ~ 40GHz	Jul. 29, 2011	Radiation (03CH01-CB)
Spectrum analyzer	R&S	FSP40	100056	9KHz~40GHz	Nov. 03, 2011	Radiation (03CH01-CB)
EMI Test Receiver	R&S	ESCS 30	100355	9KHz ~ 2.75GHz	Mar. 22, 2011	Radiation (03CH01-CB)
Loop Antenna	Teseq	HLA 6120	24155	9 kHz - 30 MHz	Sep. 09, 2010*	Radiation (03CH01-CB)
Turn Table	INN CO	CO 2000	N/A	0 ~ 360 degree	N/A	Radiation (03CH01-CB)
Antenna Mast	INN CO	CO2000	N/A	1 m - 4 m	N/A	Radiation (03CH01-CB)
RF Cable-low	Woken	Low Cable-1	N/A	30 MHz - 1 GHz	Nov. 17, 2011	Radiation (03CH01-CB)
RF Cable-high	Woken	High Cable-1	N/A	1 GHz – 26.5 GHz	Nov. 17, 2011	Radiation (03CH01-CB)
RF Cable-high	Woken	High Cable-2	N/A	1 GHz – 26.5 GHz	Nov. 17, 2011	Radiation (03CH01-CB)
RF Cable-high	Woken	High Cable-3	N/A	1 GHz - 40 GHz	Nov. 17, 2011	Radiation (03CH01-CB)
RF Cable-high	Woken	High Cable-4	N/A	1 GHz - 40 GHz	Nov. 17, 2011	Radiation (03CH01-CB)
Spectrum analyzer	R&S	FSV30	101026	9KHz~30GHz	Jul. 27, 2011	Conducted (TH01-CB)
Temp. and Humidity Chamber	Ten Billion	TTH-D3SP	TBN-931011	-30~100 degree	May 20, 2011	Conducted (TH01-CB)
Thermo-Hygro Meter	N/A	HC 520	#1	15~70 degree	Nov. 02, 2011	Conducted (TH01-CB)
RF Power Divider	HP	11636A	00306	2GHz ~ 18GHz	N/A	Conducted (TH01-CB)



Instrument	Manufacturer	Model No.	Serial No.	Characteristics	Calibration Date	Remark
RF Power Splitter	Anaren	44100	1839	2GHz ~ 18GHz	N/A	Conducted (TH01-CB)
RF Power Splitter	Anaren	42100	17930	2GHz ~ 18GHz	N/A	Conducted (TH01-CB)
EPM-P Series Power Meter	Agilent	E4416A	GB41291199	50MHz – 18GHz	Sep. 09, 2011	Conducted (TH01-CB)
Peak an Avg Power Sensor	Agilent	E9327A	US40442088	50MHz – 18GHz	Sep. 09, 2011	Conducted (TH01-CB)
RF Cable-high	Woken	High Cable-7	-	1 GHz – 26.5 GHz	Nov. 17, 2011	Conducted (TH01-CB)
RF Cable-high	Woken	High Cable-8	-	1 GHz – 26.5 GHz	Nov. 17, 2011	Conducted (TH01-CB)
RF Cable-high	Woken	High Cable-9	-	1 GHz – 26.5 GHz	Nov. 17, 2011	Conducted (TH01-CB)
RF Cable-high	Woken	High Cable-10	-	1 GHz – 26.5 GHz	Nov. 17, 2011	Conducted (TH01-CB)
RF Cable-high	Woken	High Cable-11	-	1 GHz – 26.5 GHz	Nov. 17, 2011	Conducted (TH01-CB)
RF Cable-high	Woken	High Cable-12	-	1 GHz – 26.5 GHz	Nov. 17, 2011	Conducted (TH01-CB)
RF Cable-high	Woken	High Cable-13	-	1 GHz – 26.5 GHz	Nov. 17, 2011	Conducted (TH01-CB)
Power Sensor	Anritsu	MA2411B	0917223	300MHz~40GHz	Nov. 01, 2011	Conducted (TH01-CB)
Power Meter	Anritsu	ML2495A	1035008	300MHz~40GHz	Nov. 01, 2011	Conducted (TH01-CB)

Note: Calibration Interval of instruments listed above is one year.

Note: “*” Calibration Interval of instruments listed above is two years.

6. TEST LOCATION

SHIJR	ADD : 6Fl., No. 106, Sec. 1, Shintai 5th Rd., Shijr City, Taipei, Taiwan 221, R.O.C. TEL : 886-2-2696-2468 FAX : 886-2-2696-2255
HWA YA	ADD : No. 52, Hwa Ya 1st Rd., Kwei-Shan Hsiang, Tao Yuan Hsien, Taiwan, R.O.C. TEL : 886-3-327-3456 FAX : 886-3-318-0055
LINKOU	ADD : No. 30-2, Dingfu Tsuen, Linkou Shiang, Taipei, Taiwan 244, R.O.C TEL : 886-2-2601-1640 FAX : 886-2-2601-1695
DUNGHU	ADD : No. 3, Lane 238, Kangle St., Neihu Chiu, Taipei, Taiwan 114, R.O.C. TEL : 886-2-2631-4739 FAX : 886-2-2631-9740
JUNGHE	ADD : 7Fl., No. 758, Jungjeng Rd., Junghe City, Taipei, Taiwan 235, R.O.C. TEL : 886-2-8227-2020 FAX : 886-2-8227-2626
NEIHU	ADD : 4Fl., No. 339, Hsin Hu 2 nd Rd., Taipei 114, Taiwan, R.O.C. TEL : 886-2-2794-8886 FAX : 886-2-2794-9777
JHUBEI	ADD : No.8, Lane 724, Bo-ai St., Jhubei City, HsinChu County 302, Taiwan, R.O.C. TEL : 886-3-656-9065 FAX : 886-3-656-9085

7. TAF CERTIFICATE OF ACCREDITATION



Certificate No. : L1190-110702

財團法人全國認證基金會
Taiwan Accreditation Foundation

Certificate of Accreditation

This is to certify that

Sporton International Inc.
EMC & Wireless Communications Laboratory
No.52, Hwa Ya 1st Road, Hwa Ya Technology Park, Kwei-Shan Hsiang, Tao Yuan Hsien,
Taiwan, R.O.C.

is accredited in respect of laboratory

Accreditation Criteria	: ISO/IEC 17025:2005
Accreditation Number	: 1190
Originally Accredited	: December 15, 2003
Effective Period	: January 10, 2010 to January 09, 2013
Accredited Scope	: Testing Field, see described in the Appendix
Specific Accreditation Program	: Accreditation Program for Designated Testing Laboratory for Commodities Inspection Accreditation Program for Telecommunication Equipment Testing Laboratory Accreditation Program for BSMI Mutual Recognition Arrangement with Foreign Authorities

Jay-San Chen
President, Taiwan Accreditation Foundation
Date : July 02, 2011

P1, total 22 pages

The Appendix forms an integral part of this Certificate, which shall be invalid when use without the Appendix