

20120614_SystemPerformanceCheck-D1900V2 SN 5d043

Frequency: 1900 MHz; Duty Cycle: 1:1; Room Ambient Temperature: 24.0°C; Liquid Temperature: 23.0°C
Medium parameters used: $f = 1900$ MHz; $\sigma = 1.529$ mho/m; $\epsilon_r = 51.874$; $\rho = 1000$ kg/m³

DASY5 Configuration:

- Electronics: DAE4 Sn1259; Calibrated: 2/13/2012
- Probe: EX3DV4 - SN3686; ConvF(7.04, 7.04, 7.04); Calibrated: 2/16/2012
- Sensor-Surface: 2.5mm (Mechanical Surface Detection)
- Phantom: ELI v5.0 (B); Type: QDOVA001BB; Serial: 1118

Body/Pin=100 mW/Area Scan (7x7x1): Measurement grid: dx=15mm, dy=15mm

Maximum value of SAR (measured) = 3.558 mW/g

Body/Pin=100 mW/Zoom Scan (7x7x7)/Cube 0: Measurement grid: dx=5mm, dy=5mm, dz=5mm

Reference Value = 59.036 V/m; Power Drift = 0.01 dB

Peak SAR (extrapolated) = 7.1290

SAR(1 g) = 4.02 mW/g; SAR(10 g) = 2.12 mW/g

Maximum value of SAR (measured) = 5.399 mW/g

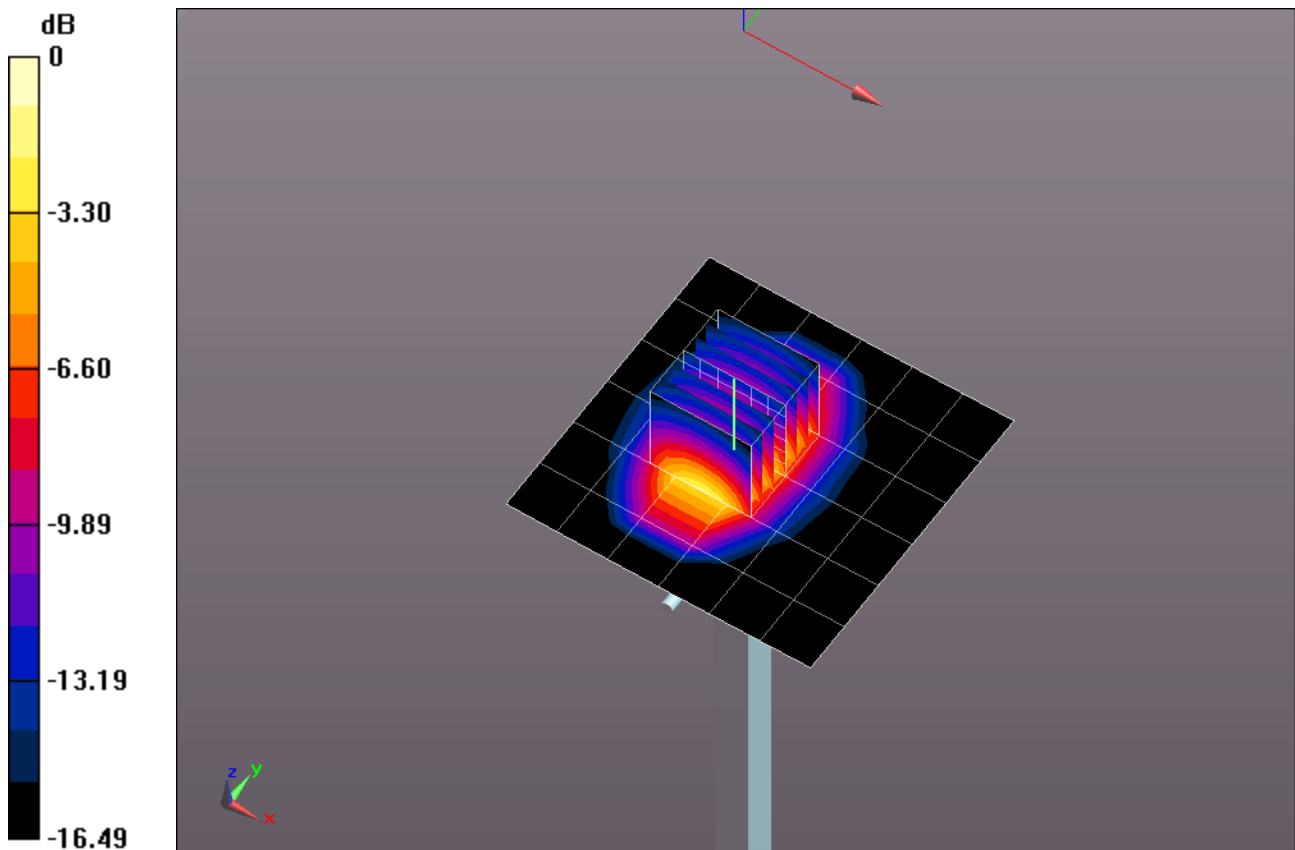

0 dB = 5.400mW/g = 14.65 dB mW/g

20120614_SystemPerformanceCheck-D1900V2 SN 5d043

Frequency: 1900 MHz; Duty Cycle: 1:1

Body/Pin=100 mW/Z Scan (1x1x21): Measurement grid: dx=20mm, dy=20mm, dz=5mm
Maximum value of SAR (measured) = 3.354 mW/g

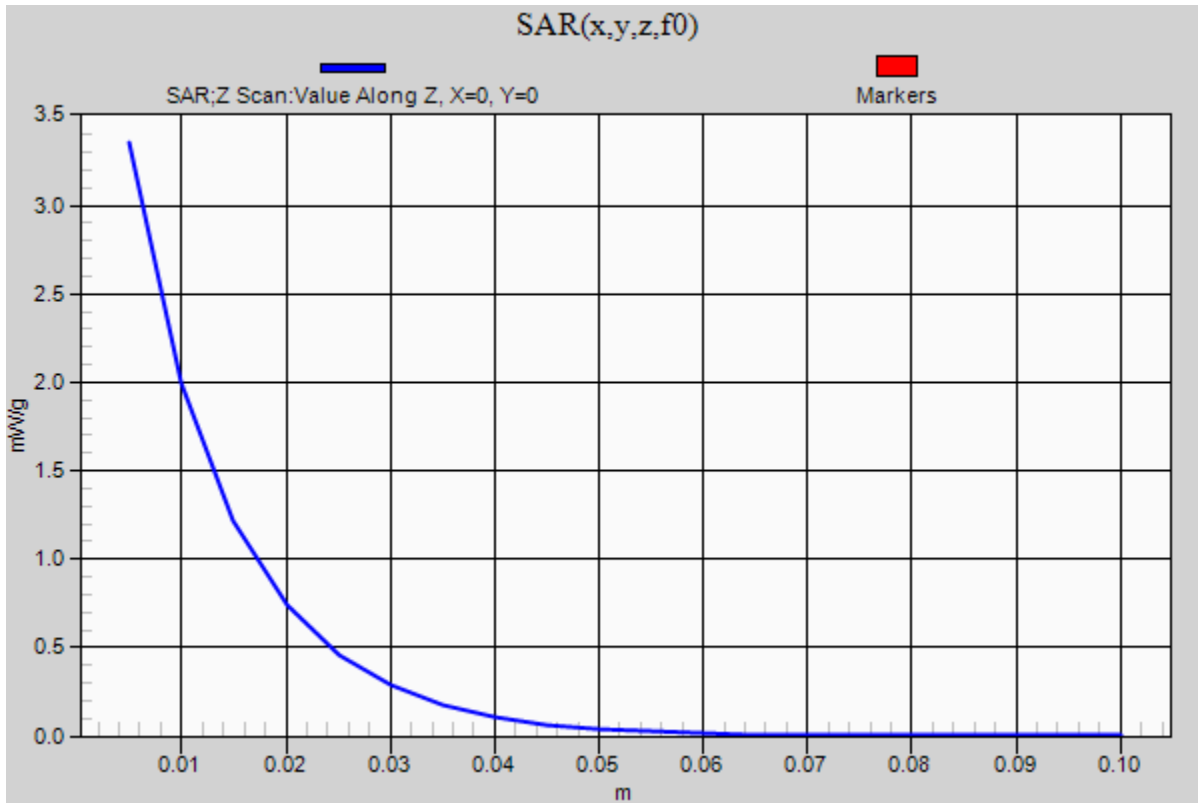

20120616_SystemPerformanceCheck-D2450V2 SN 748

Frequency: 2450 MHz; Duty Cycle: 1:1; Room Ambient Temperature: 24.0°C; Liquid Temperature: 23.0°C

Medium parameters used: $f = 2450$ MHz; $\sigma = 1.996$ mho/m; $\epsilon_r = 51.737$; $\rho = 1000$ kg/m³

DASY5 Configuration:

- Area Scan setting - Find Secondary Maximum Within: 2.0 dB and with a peak SAR value greater than 0.0012W/kg
- Electronics: DAE4 Sn1258; Calibrated: 3/8/2012
- Probe: EX3DV4 - SN3772; ConvF(6.65, 6.65, 6.65); Calibrated: 2/16/2012;
- Sensor-Surface: 2.5mm (Mechanical Surface Detection)
- Phantom: ELI v5.0 (A); Type: QDOVA001BB; Serial: 1120

Body/Pin=100 mW/Area Scan (7x7x1): Measurement grid: dx=15mm, dy=15mm

Maximum value of SAR (measured) = 5.93 mW/g

Body/Pin=100 mW/Zoom Scan (7x7x7)/Cube 0: Measurement grid: dx=5mm, dy=5mm, dz=5mm

Reference Value = 61.524 V/m; Power Drift = -0.05 dB

Peak SAR (extrapolated) = 11.105 mW/g

SAR(1 g) = 5.31 mW/g; SAR(10 g) = 2.47 mW/g

Maximum value of SAR (measured) = 7.54 mW/g

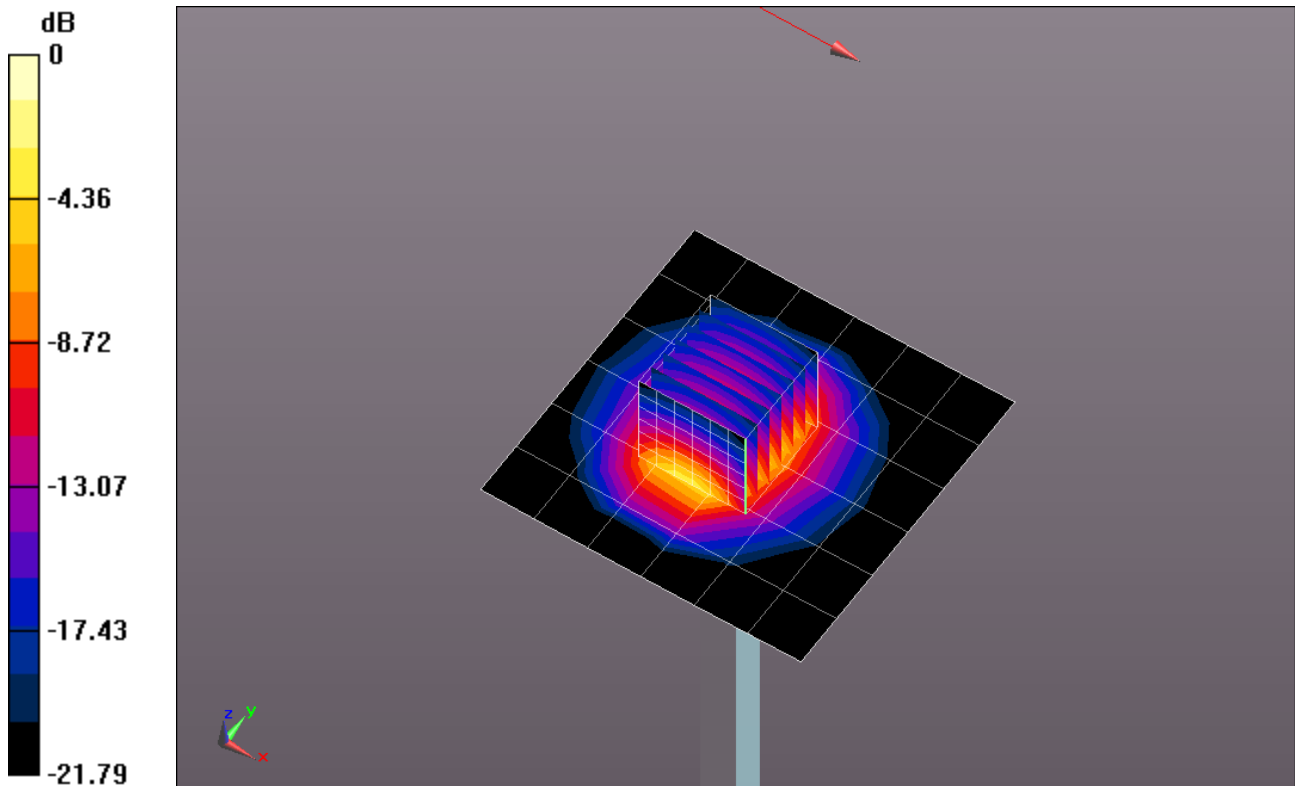

0 dB = 7.54 mW/g = 17.55 dB mW/g

20120616_SystemPerformanceCheck-D2450V2 SN 748

Frequency: 2450 MHz; Duty Cycle: 1:1

Body/Pin=100 mW/Z Scan (1x1x21): Measurement grid: dx=20mm, dy=20mm, dz=5mm
Maximum value of SAR (measured) = 3.97 mW/g

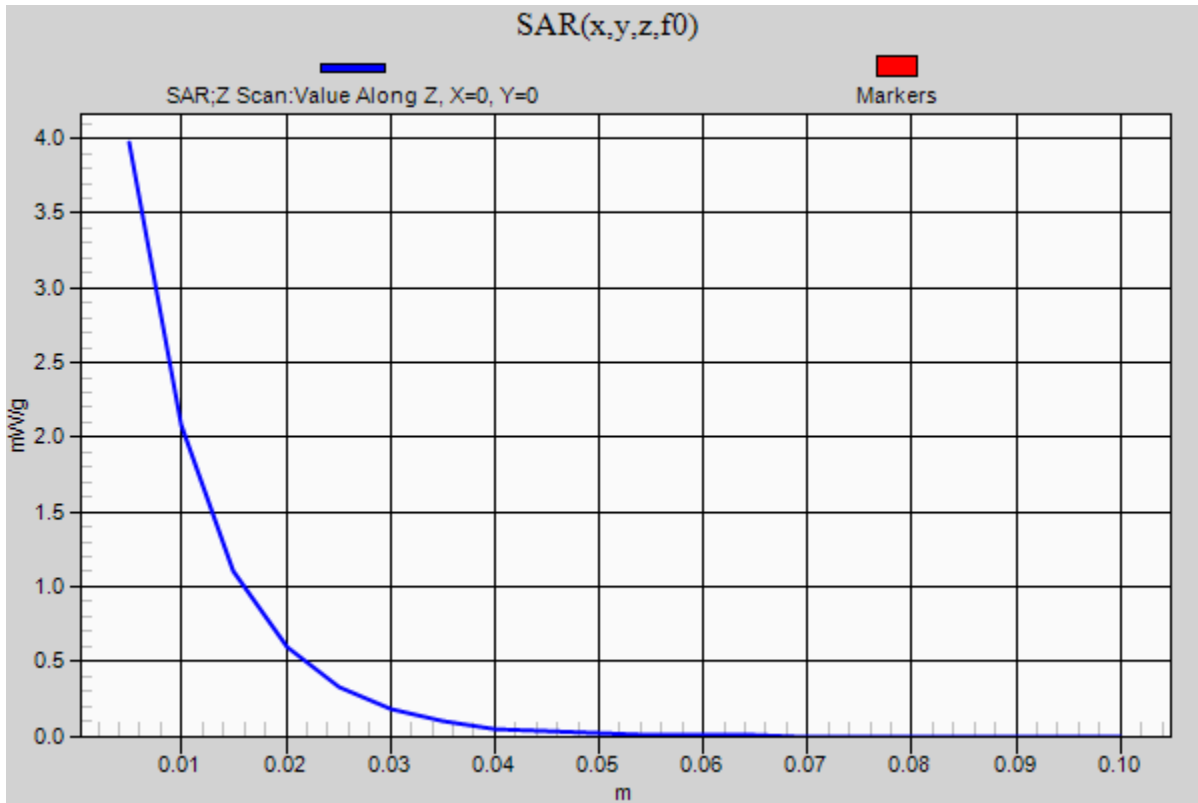

20120618_SystemPerformanceCheck-D5GHzV2 SN 1075

Frequency: 5800 MHz; Duty Cycle: 1:1; Room Ambient Temperature: 25.0°C; Liquid Temperature: 24.0°C

Medium parameters used: $f = 5800$ MHz; $\sigma = 5.92$ mho/m; $\epsilon_r = 49.854$; $\rho = 1000$ kg/m³

DASY5 Configuration:

- Area Scan setting - Find Secondary Maximum Within: 2.0 dB and with a peak SAR value greater than 0.0012W/kg
- Electronics: DAE4 Sn1259; Calibrated: 2/13/2012
- Probe: EX3DV4 - SN3686; ConvF(3.57, 3.57, 3.57); Calibrated: 2/16/2012
- Sensor-Surface: 2.5mm (Mechanical Surface Detection)
- Phantom: ELI v5.0 (A); Type: QDOVA001BB; Serial: 1120

Body/5.8 GHz, Pin=100mW/Area Scan (7x7x1): Measurement grid: dx=10mm, dy=10mm

Maximum value of SAR (measured) = 10.029 mW/g

Body/5.8 GHz, Pin=100mW/Zoom Scan (8x8x10)/Cube 0: Measurement grid: dx=4mm, dy=4mm,

dz=2.5mm

Reference Value = 45.057 V/m; Power Drift = 0.14 dB

Peak SAR (extrapolated) = 26.8630

SAR(1 g) = 7.37 mW/g; SAR(10 g) = 2.05 mW/g

Maximum value of SAR (measured) = 13.381 mW/g

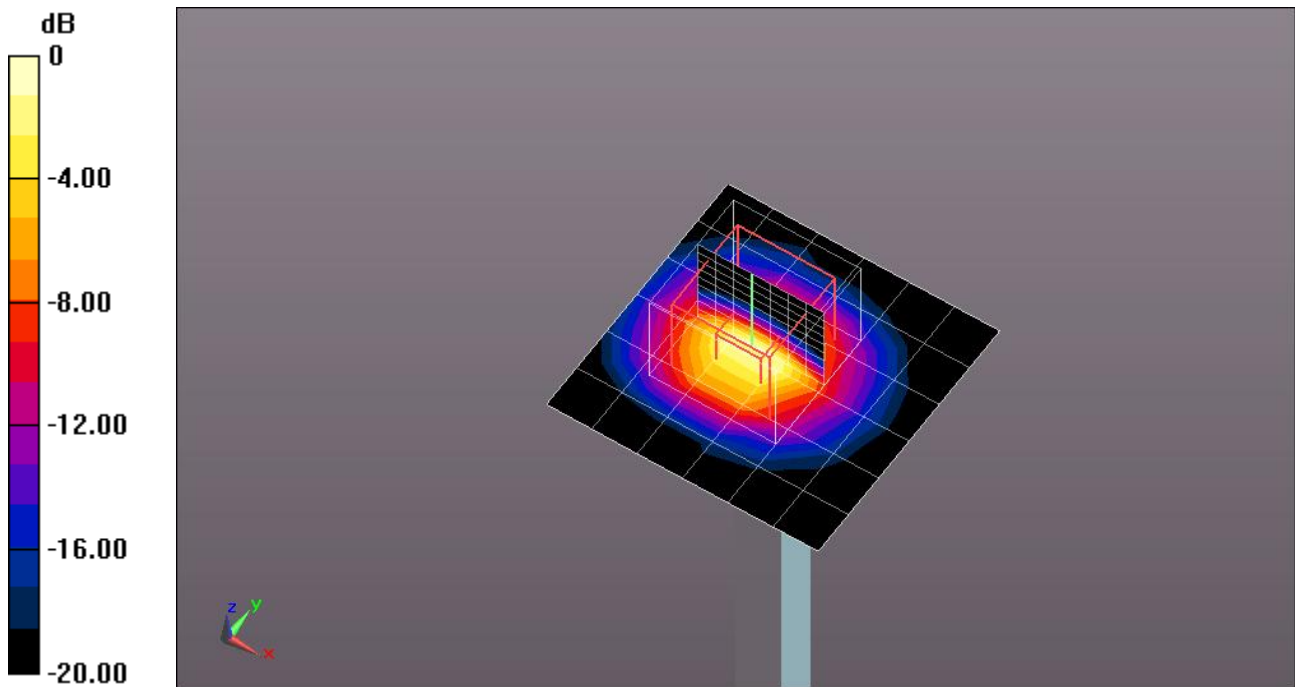

0 dB = 13.380mW/g = 22.53 dB mW/g

20120618_SystemPerformanceCheck-D5GHzV2 SN 1075

Frequency: 5800 MHz; Duty Cycle: 1:1

Body/5.8 GHz, Pin=100mW/Z Scan (1x1x21): Measurement grid: dx=20mm, dy=20mm, dz=5mm
Maximum value of SAR (measured) = 1.694 mW/g

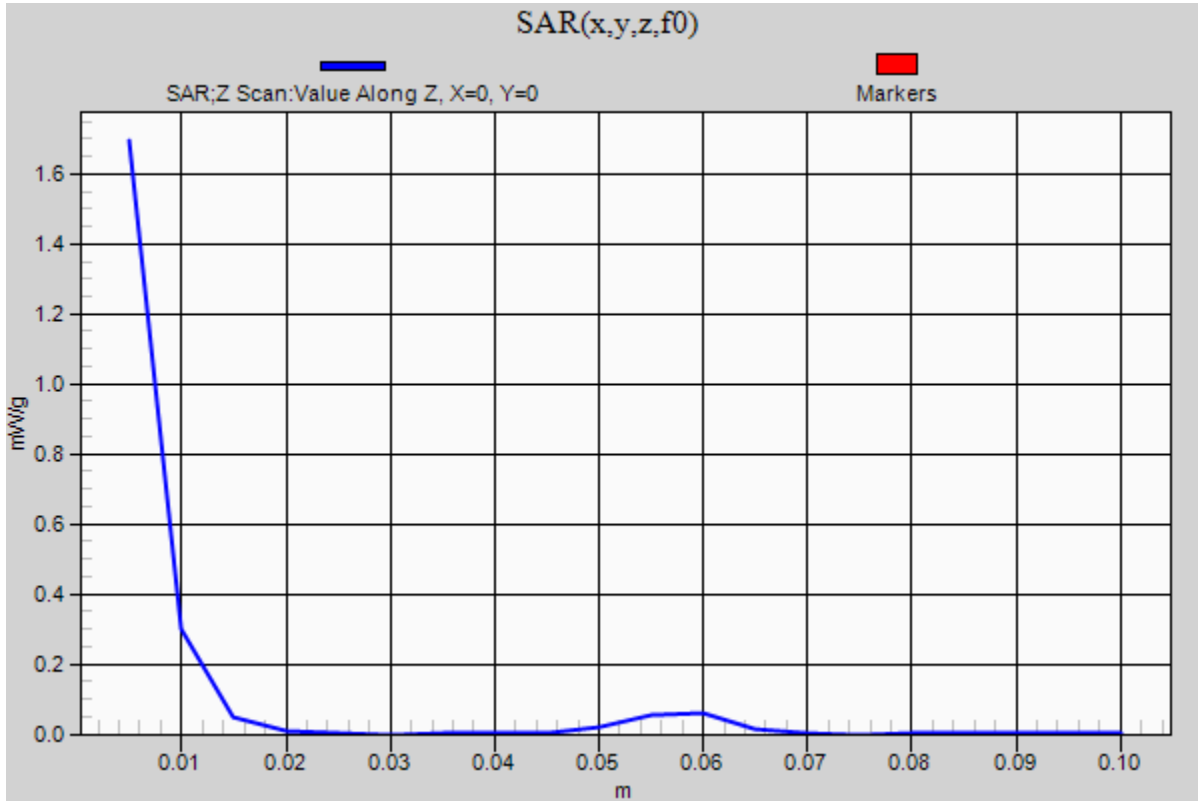

20120620_SystemPerformanceCheck-D5GHzV2 SN 1075

Frequency: 5800 MHz; Duty Cycle: 1:1; Room Ambient Temperature: 25.0°C; Liquid Temperature: 24.0°C

Medium parameters used: $f = 5800$ MHz; $\sigma = 6.066$ mho/m; $\epsilon_r = 50.353$; $\rho = 1000$ kg/m³

DASY5 Configuration:

- Area Scan setting - Find Secondary Maximum Within: 2.0 dB and with a peak SAR value greater than 0.0012W/kg
- Electronics: DAE4 Sn1259; Calibrated: 2/13/2012
- Probe: EX3DV4 - SN3686; ConvF(3.57, 3.57, 3.57); Calibrated: 2/16/2012
- Sensor-Surface: 2.5mm (Mechanical Surface Detection)
- Phantom: ELI v5.0 (A); Type: QDOVA001BB; Serial: 1120

Body/5.8 GHz, Pin=100mW/Area Scan (7x7x1): Measurement grid: dx=10mm, dy=10mm

Maximum value of SAR (measured) = 10.229 mW/g

Body/5.8 GHz, Pin=100mW/Zoom Scan (8x8x10)/Cube 0: Measurement grid: dx=4mm, dy=4mm,

dz=2.5mm

Reference Value = 43.869 V/m; Power Drift = 0.22 dB

Peak SAR (extrapolated) = 28.3020

SAR(1 g) = 7.7 mW/g; SAR(10 g) = 2.16 mW/g

Maximum value of SAR (measured) = 14.270 mW/g

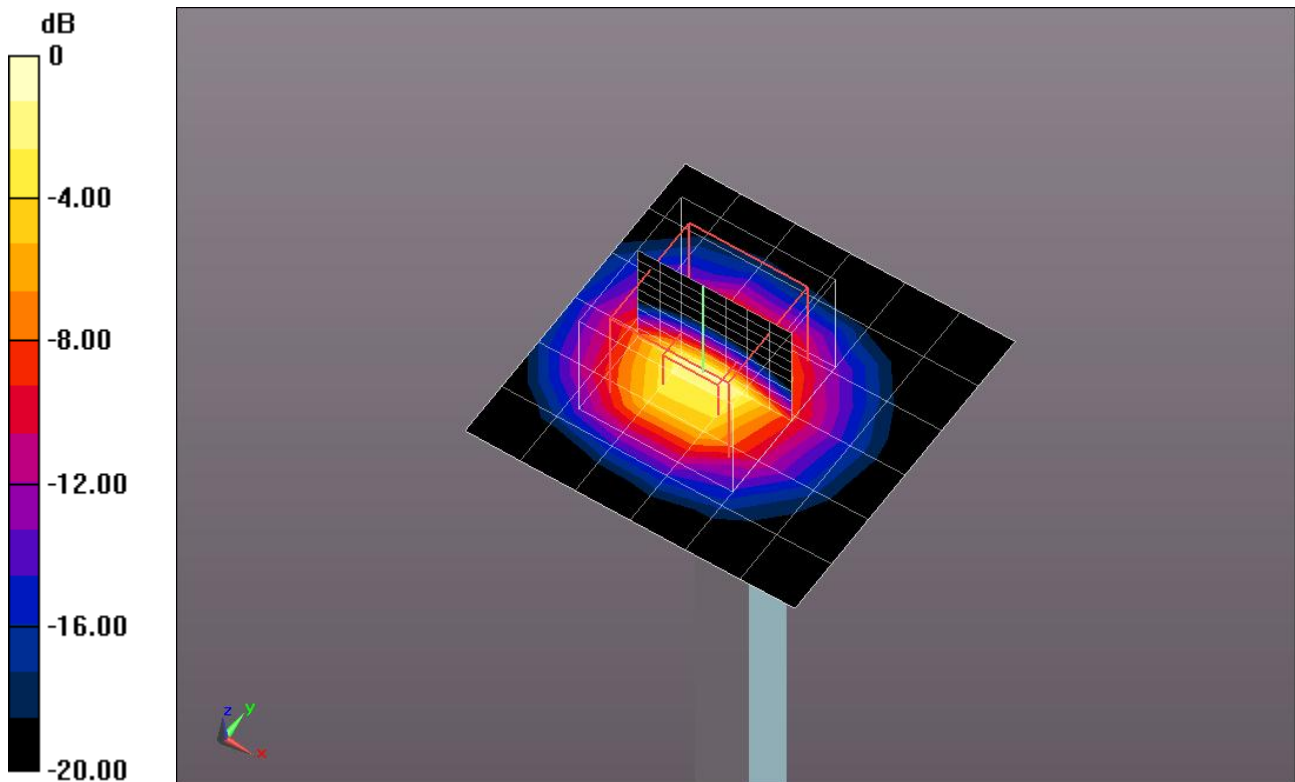

0 dB = 14.270mW/g = 23.09 dB mW/g

20120620_SystemPerformanceCheck-D5GHzV2 SN 1075

Frequency: 5800 MHz; Duty Cycle: 1:1

Body/5.8 GHz, Pin=100mW/Z Scan (1x1x21): Measurement grid: dx=20mm, dy=20mm, dz=5mm
Maximum value of SAR (measured) = 1.643 mW/g

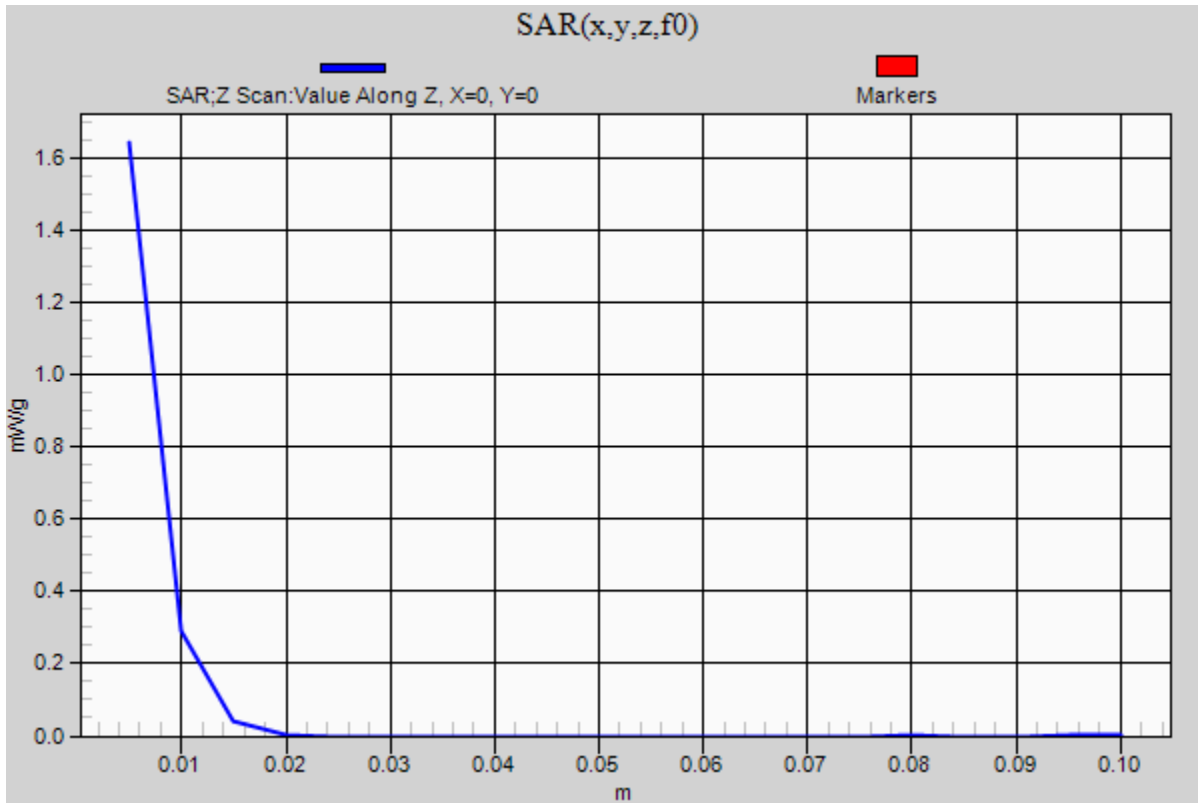

20120620_SystemPerformanceCheck-D5GHzV2 SN 1075

Frequency: 5500 MHz; Duty Cycle: 1:1; Room Ambient Temperature: 25.0°C; Liquid Temperature: 24.0°C

Medium parameters used: $f = 5500$ MHz; $\sigma = 5.646$ mho/m; $\epsilon_r = 50.957$; $\rho = 1000$ kg/m³

DASY5 Configuration:

- Area Scan setting - Find Secondary Maximum Within: 2.0 dB and with a peak SAR value greater than 0.0012W/kg
- Electronics: DAE4 Sn1259; Calibrated: 2/13/2012
- Probe: EX3DV4 - SN3686; ConvF(3.62, 3.62, 3.62); Calibrated: 2/16/2012
- Sensor-Surface: 2.5mm (Mechanical Surface Detection)
- Phantom: ELI v5.0 (A); Type: QDOVA001BB; Serial: 1120

Body/5.5 GHz, Pin=100mW/Area Scan (7x7x1): Measurement grid: dx=10mm, dy=10mm

Maximum value of SAR (measured) = 13.887 mW/g

Body/5.5 GHz, Pin=100mW/Zoom Scan (8x8x10)/Cube 0: Measurement grid: dx=4mm, dy=4mm,

dz=2.5mm

Reference Value = 53.317 V/m; Power Drift = 0.16 dB

Peak SAR (extrapolated) = 29.0240

SAR(1 g) = 8.15 mW/g; SAR(10 g) = 2.3 mW/g

Maximum value of SAR (measured) = 15.067 mW/g

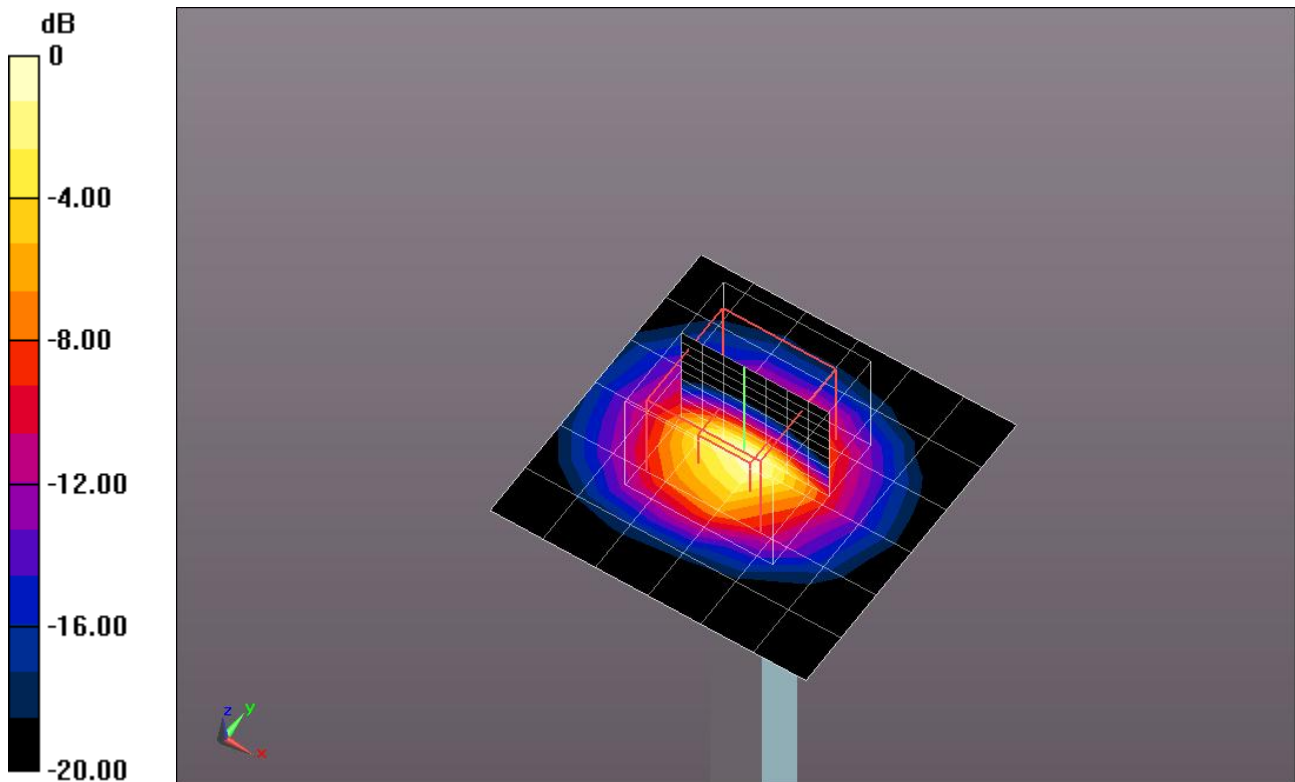

0 dB = 15.070mW/g = 23.56 dB mW/g

20120620_SystemPerformanceCheck-D5GHzV2 SN 1075

Frequency: 5500 MHz; Duty Cycle: 1:1

Body/5.5 GHz, Pin=100mW/Z Scan (1x1x21): Measurement grid: dx=20mm, dy=20mm, dz=5mm
Maximum value of SAR (measured) = 3.364 mW/g

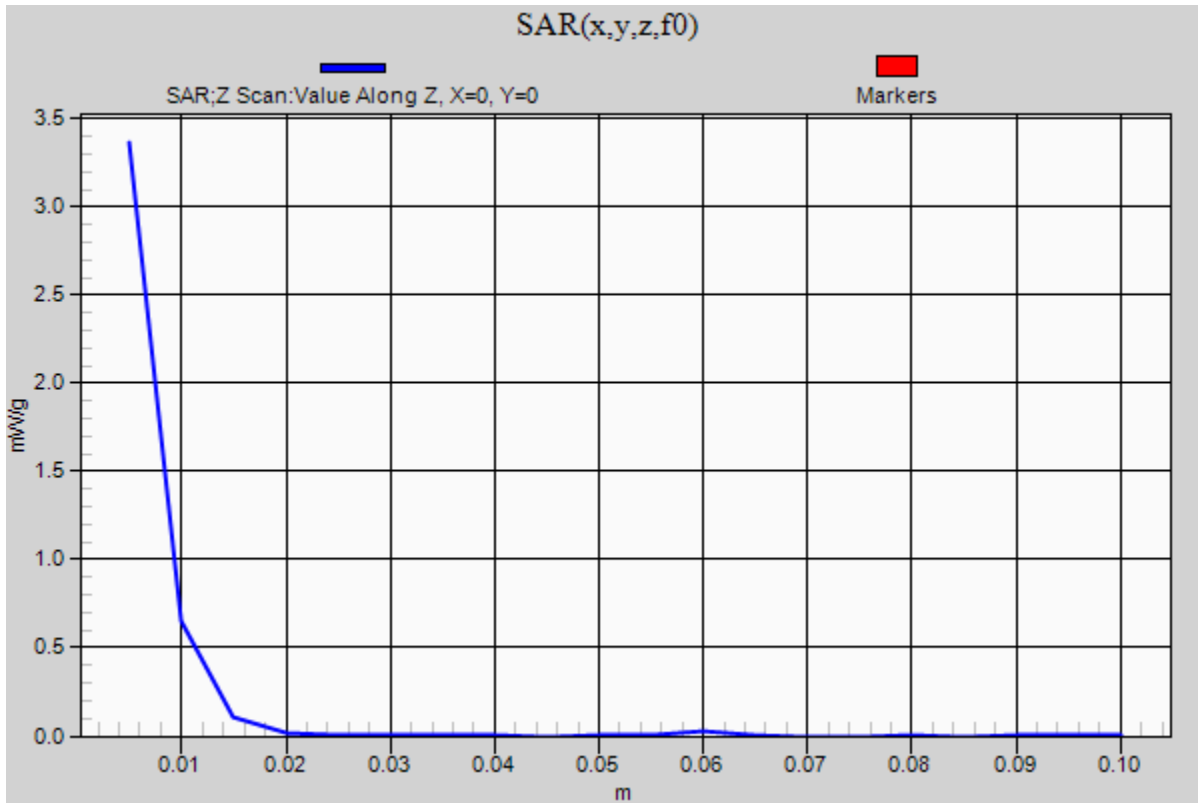

20120621_SystemPerformanceCheck-D5GHzV2 SN 1075

Frequency: 5200 MHz; Duty Cycle: 1:1; Room Ambient Temperature: 25.0°C; Liquid Temperature: 24.0°C

Medium parameters used: $f = 5200$ MHz; $\sigma = 5.256$ mho/m; $\epsilon_r = 51.216$; $\rho = 1000$ kg/m³

DASY5 Configuration:

- Area Scan setting - Find Secondary Maximum Within: 2.0 dB and with a peak SAR value greater than 0.0012W/kg
- Electronics: DAE4 Sn1259; Calibrated: 2/13/2012
- Probe: EX3DV4 - SN3686; ConvF(4.04, 4.04, 4.04); Calibrated: 2/16/2012
- Sensor-Surface: 2.5mm (Mechanical Surface Detection)
- Phantom: ELI v5.0 (A); Type: QDOVA001BB; Serial: 1120

Body/5.2 GHz, Pin=100mW/Area Scan (7x7x1): Measurement grid: dx=10mm, dy=10mm

Maximum value of SAR (measured) = 13.126 mW/g

Body/5.2 GHz, Pin=100mW/Zoom Scan (8x8x10)/Cube 0: Measurement grid: dx=4mm, dy=4mm,

dz=2.5mm

Reference Value = 53.764 V/m; Power Drift = 0.11 dB

Peak SAR (extrapolated) = 26.8800

SAR(1 g) = 7.78 mW/g; SAR(10 g) = 2.21 mW/g

Maximum value of SAR (measured) = 14.178 mW/g

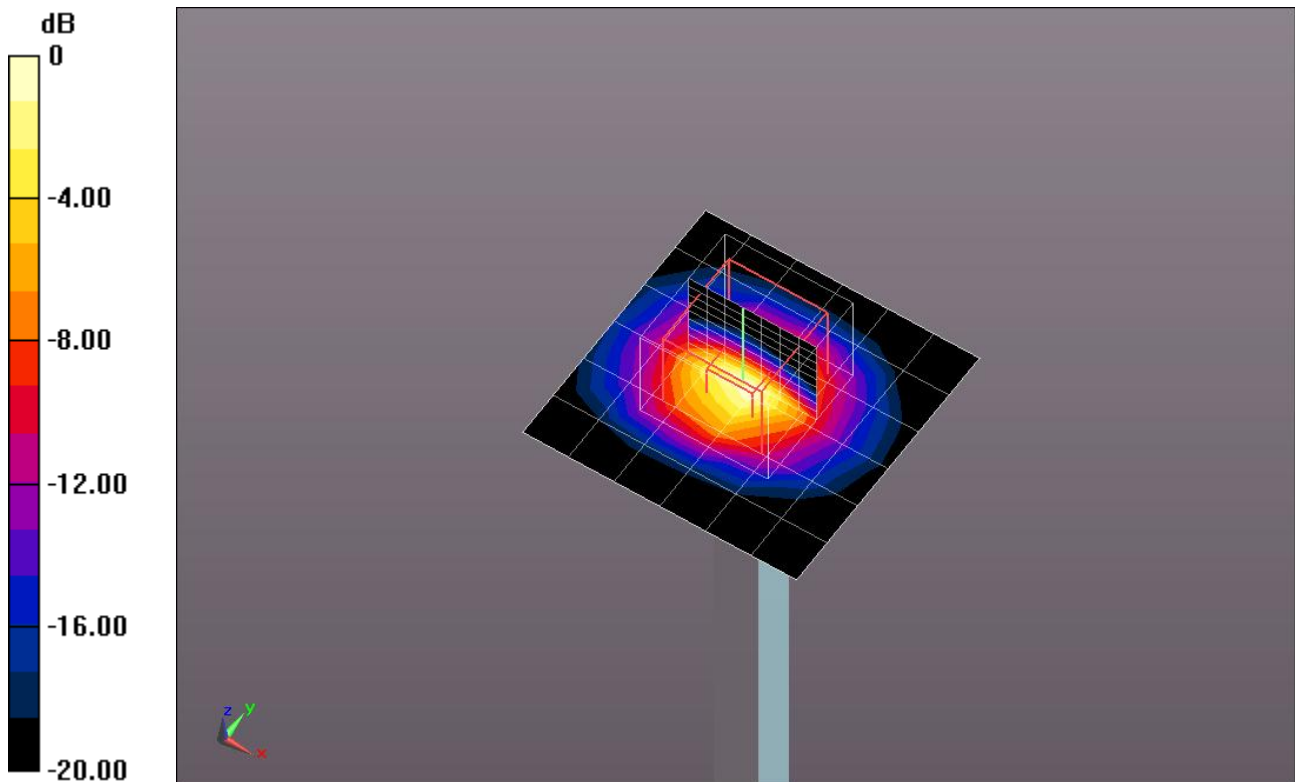

0 dB = 14.180mW/g = 23.03 dB mW/g

20120621_SystemPerformanceCheck-D5GHzV2 SN 1075

Frequency: 5200 MHz; Duty Cycle: 1:1

Body/5.2 GHz, Pin=100mW/Z Scan (1x1x21): Measurement grid: dx=20mm, dy=20mm, dz=5mm
Maximum value of SAR (measured) = 3.445 mW/g

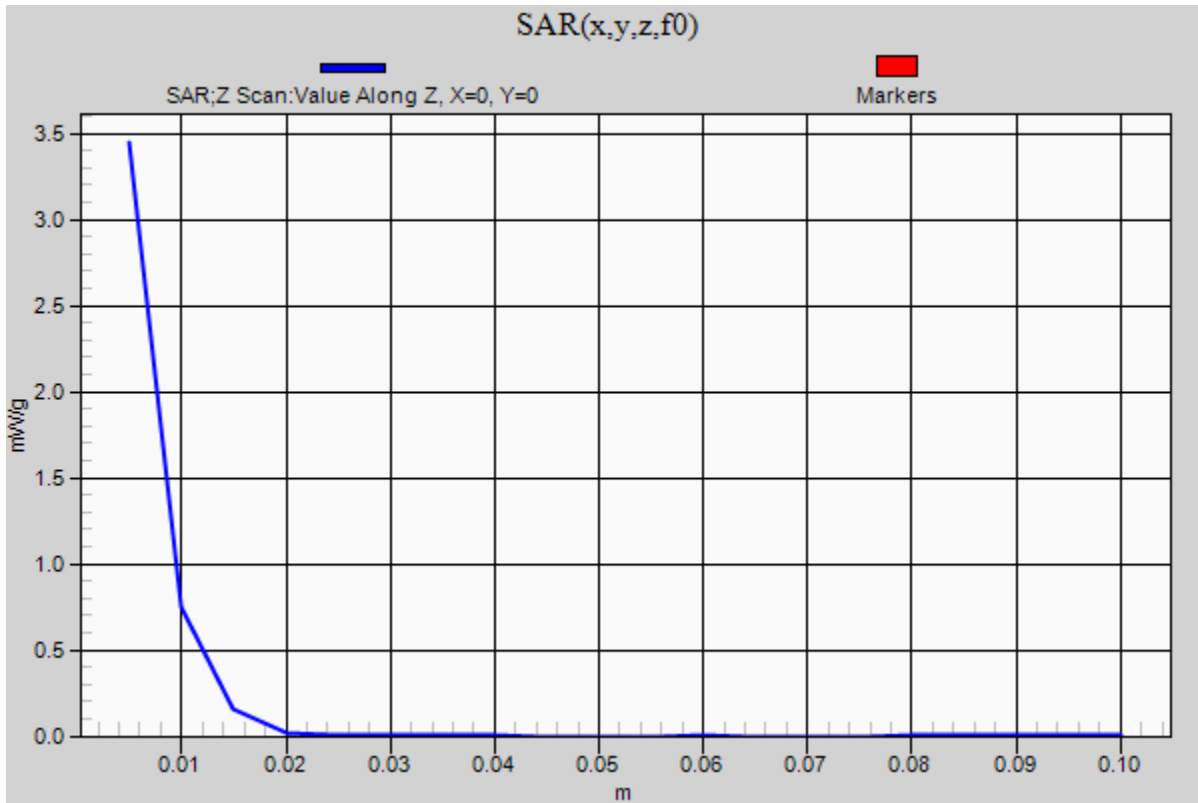

20120621_SystemPerformanceCheck-D1900V2 SN 5d043

Frequency: 1900 MHz; Duty Cycle: 1:1; Room Ambient Temperature: 24.0°C; Liquid Temperature: 23.0°C

Medium parameters used: $f = 1900$ MHz; $\sigma = 1.53$ mho/m; $\epsilon_r = 50.735$; $\rho = 1000$ kg/m³

DASY5 Configuration:

- Area Scan setting - Find Secondary Maximum Within: 2.0 dB and with a peak SAR value greater than 0.0012W/kg
- Electronics: DAE4 Sn1259; Calibrated: 2/13/2012
- Probe: EX3DV4 - SN3686; ConvF(7.04, 7.04, 7.04); Calibrated: 2/16/2012
- Sensor-Surface: 2.5mm (Mechanical Surface Detection)
- Phantom: ELI v5.0 (B); Type: QDOVA001BB; Serial: 1118

Body/Pin=100 mW/Area Scan (7x7x1): Measurement grid: dx=15mm, dy=15mm

Maximum value of SAR (measured) = 4.224 mW/g

Body/Pin=100 mW/Zoom Scan (7x7x7)/Cube 0: Measurement grid: dx=5mm, dy=5mm, dz=5mm

Reference Value = 55.741 V/m; Power Drift = 0.12 dB

Peak SAR (extrapolated) = 7.3020

SAR(1 g) = 4.02 mW/g; SAR(10 g) = 2.1 mW/g

Maximum value of SAR (measured) = 5.420 mW/g

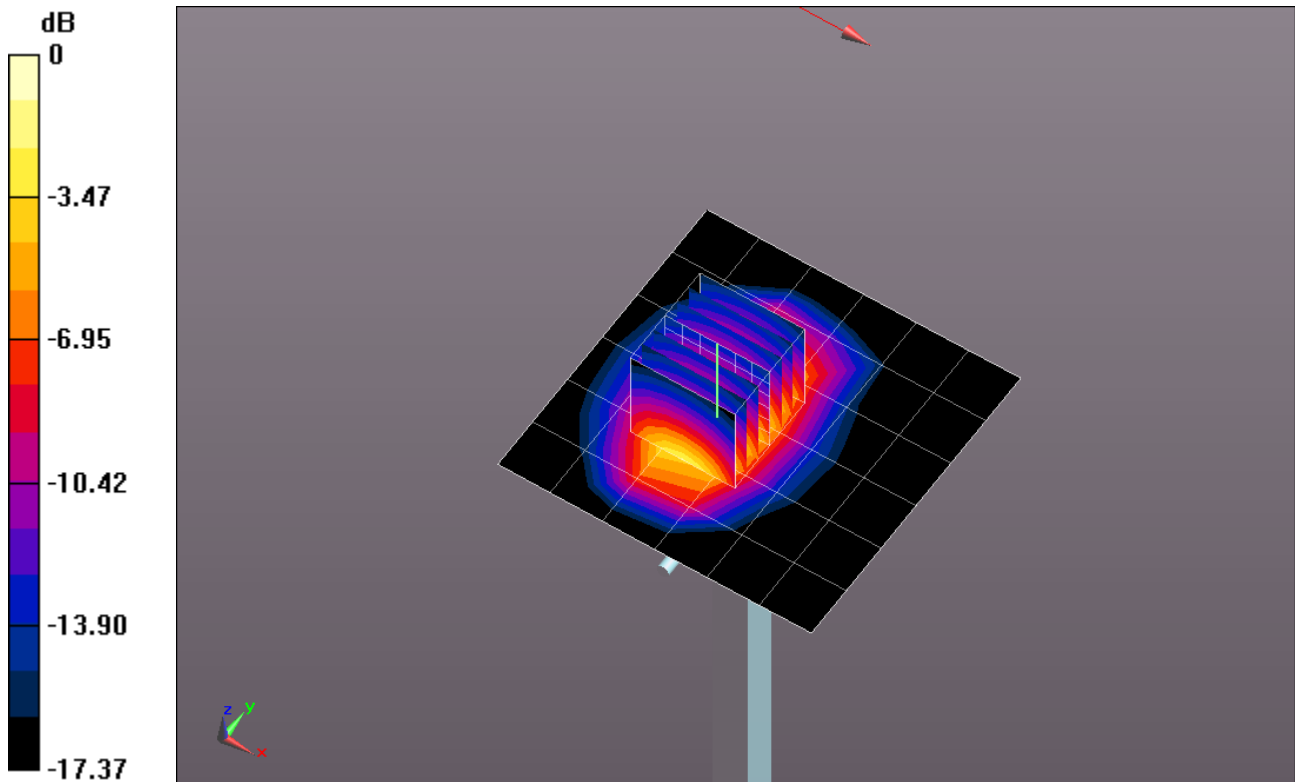

0 dB = 5.420mW/g = 14.68 dB mW/g

20120621_SystemPerformanceCheck-D1900V2 SN 5d043

Frequency: 1900 MHz; Duty Cycle: 1:1

Body/Pin=100 mW/Z Scan (1x1x21): Measurement grid: dx=20mm, dy=20mm, dz=5mm
Maximum value of SAR (measured) = 3.121 mW/g

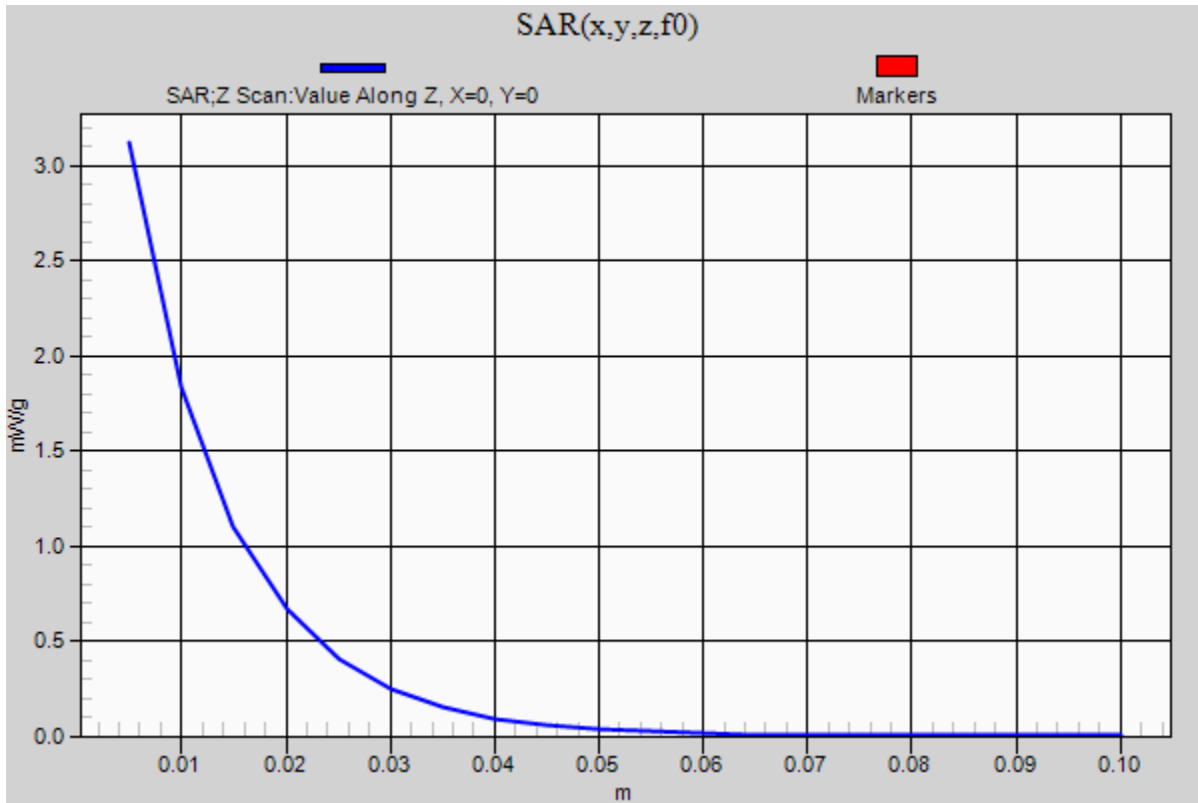

20120621_SystemPerformanceCheck-D835V2 SN 4d002

Frequency: 835 MHz; Duty Cycle: 1:1; Room Ambient Temperature: 24.0°C; Liquid Temperature: 23.0°C

Medium parameters used: $f = 835$ MHz; $\sigma = 0.991$ mho/m; $\epsilon_r = 53.838$; $\rho = 1000$ kg/m³

DASY5 Configuration:

- Area Scan setting - Find Secondary Maximum Within: 2.0 dB and with a peak SAR value greater than 0.0012W/kg
- Electronics: DAE4 Sn1259; Calibrated: 2/13/2012
- Probe: EX3DV4 - SN3686; ConvF(8.73, 8.73, 8.73); Calibrated: 2/16/2012
- Sensor-Surface: 2.5mm (Mechanical Surface Detection)
- Phantom: ELI v5.0 (A); Type: QDOVA001BB; Serial: 1120

Body/Pin=100 mW/Area Scan (7x7x1): Measurement grid: dx=15mm, dy=15mm

Maximum value of SAR (measured) = 1.173 mW/g

Body/Pin=100 mW/Zoom Scan (7x7x7)/Cube 0: Measurement grid: dx=5mm, dy=5mm, dz=5mm

Reference Value = 34.552 V/m; Power Drift = -0.07 dB

Peak SAR (extrapolated) = 1.5260

SAR(1 g) = 1.02 mW/g; SAR(10 g) = 0.672 mW/g

Maximum value of SAR (measured) = 1.247 mW/g

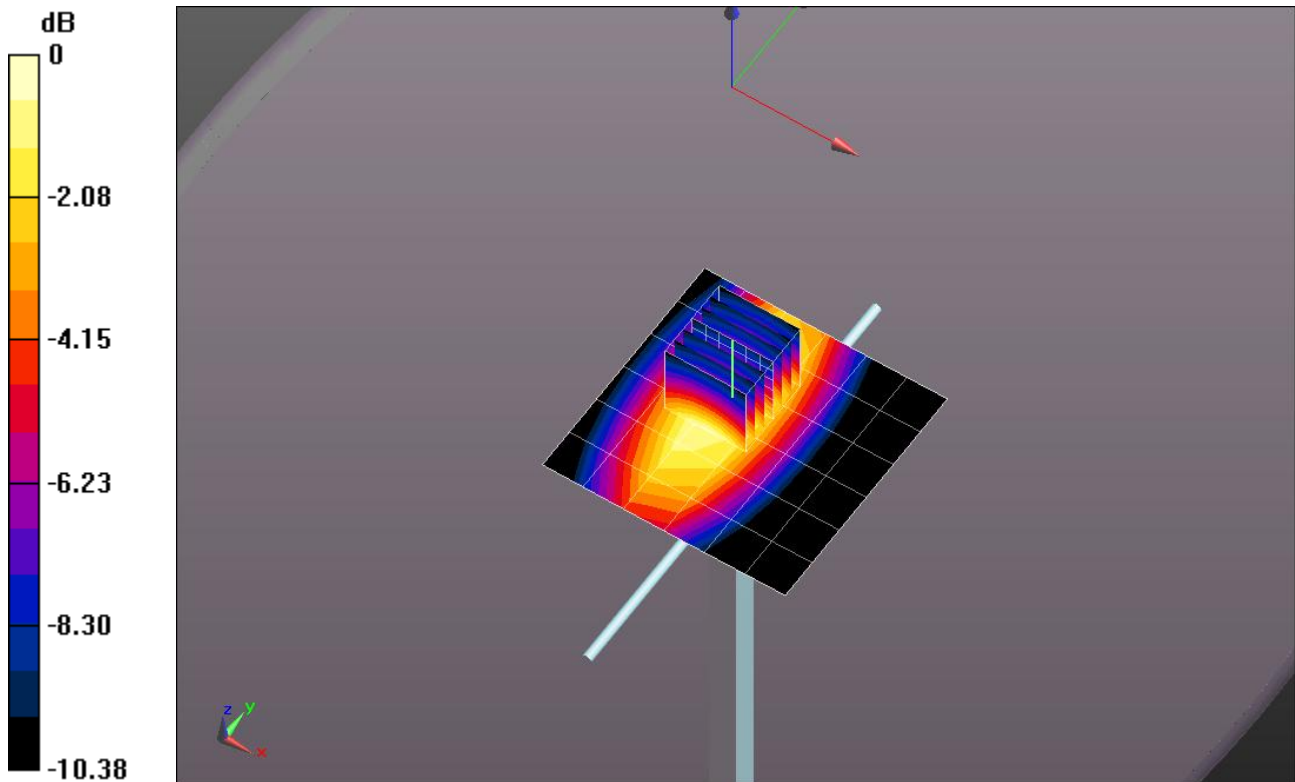

0 dB = 1.250mW/g = 1.94 dB mW/g

20120621_SystemPerformanceCheck-D835V2 SN 4d002

Frequency: 835 MHz; Duty Cycle: 1:1

Body/Pin=100 mW/Z Scan (1x1x21): Measurement grid: dx=20mm, dy=20mm, dz=5mm
Maximum value of SAR (measured) = 0.730 mW/g

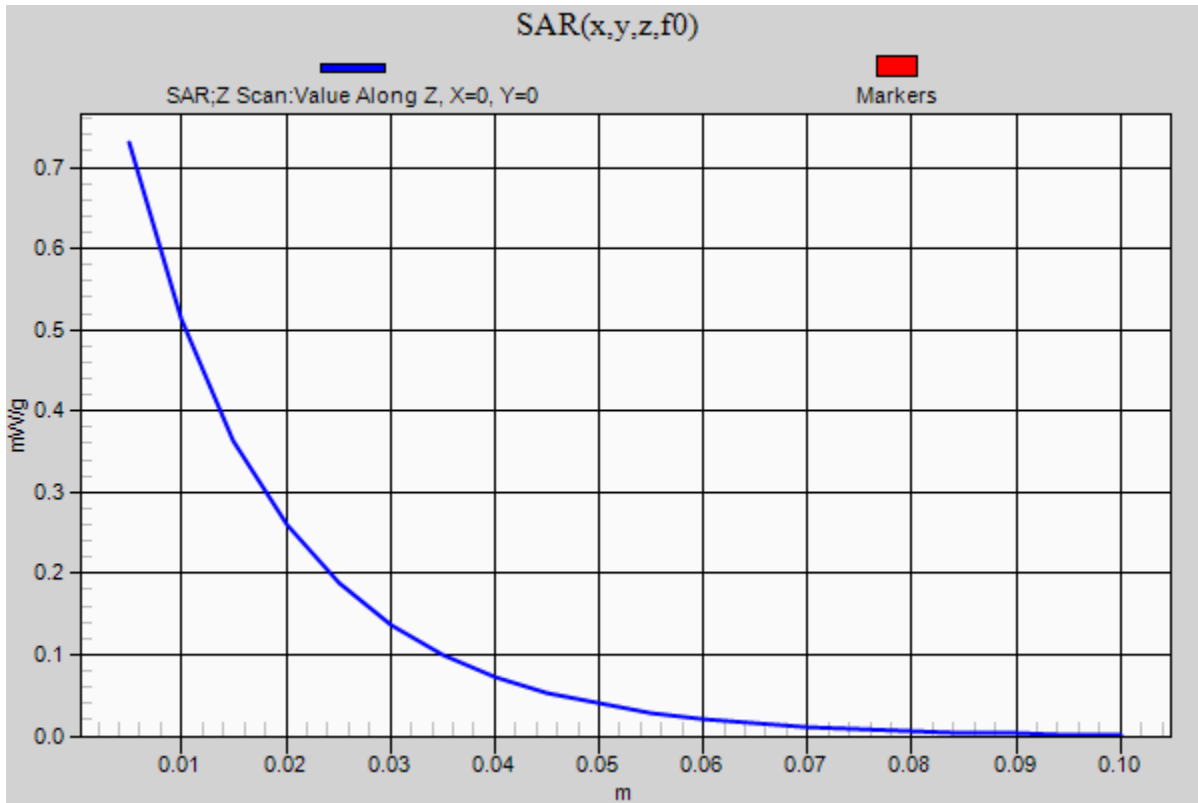

20120625_SystemPerformanceCheck-D835V2 SN 4d002

Frequency: 835 MHz; Duty Cycle: 1:1; Room Ambient Temperature: 24.0°C; Liquid Temperature: 23.0°C

Medium parameters used: $f = 835$ MHz; $\sigma = 0.966$ mho/m; $\epsilon_r = 53.832$; $\rho = 1000$ kg/m³

DASY5 Configuration:

- Area Scan setting - Find Secondary Maximum Within: 2.0 dB and with a peak SAR value greater than 0.0012W/kg
- Electronics: DAE4 Sn1259; Calibrated: 2/13/2012
- Probe: EX3DV4 - SN3686; ConvF(8.73, 8.73, 8.73); Calibrated: 2/16/2012
- Sensor-Surface: 2.5mm (Mechanical Surface Detection)
- Phantom: ELI v5.0 (A); Type: QDOVA001BB; Serial: 1120

Body/Pin=100 mW/Area Scan (7x7x1): Measurement grid: dx=15mm, dy=15mm

Maximum value of SAR (measured) = 1.066 mW/g

Body/Pin=100 mW/Zoom Scan (7x7x7)/Cube 0: Measurement grid: dx=5mm, dy=5mm, dz=5mm

Reference Value = 35.298 V/m; Power Drift = -0.0053 dB

Peak SAR (extrapolated) = 1.4640

SAR(1 g) = 0.987 mW/g; SAR(10 g) = 0.648 mW/g

Maximum value of SAR (measured) = 1.199 mW/g

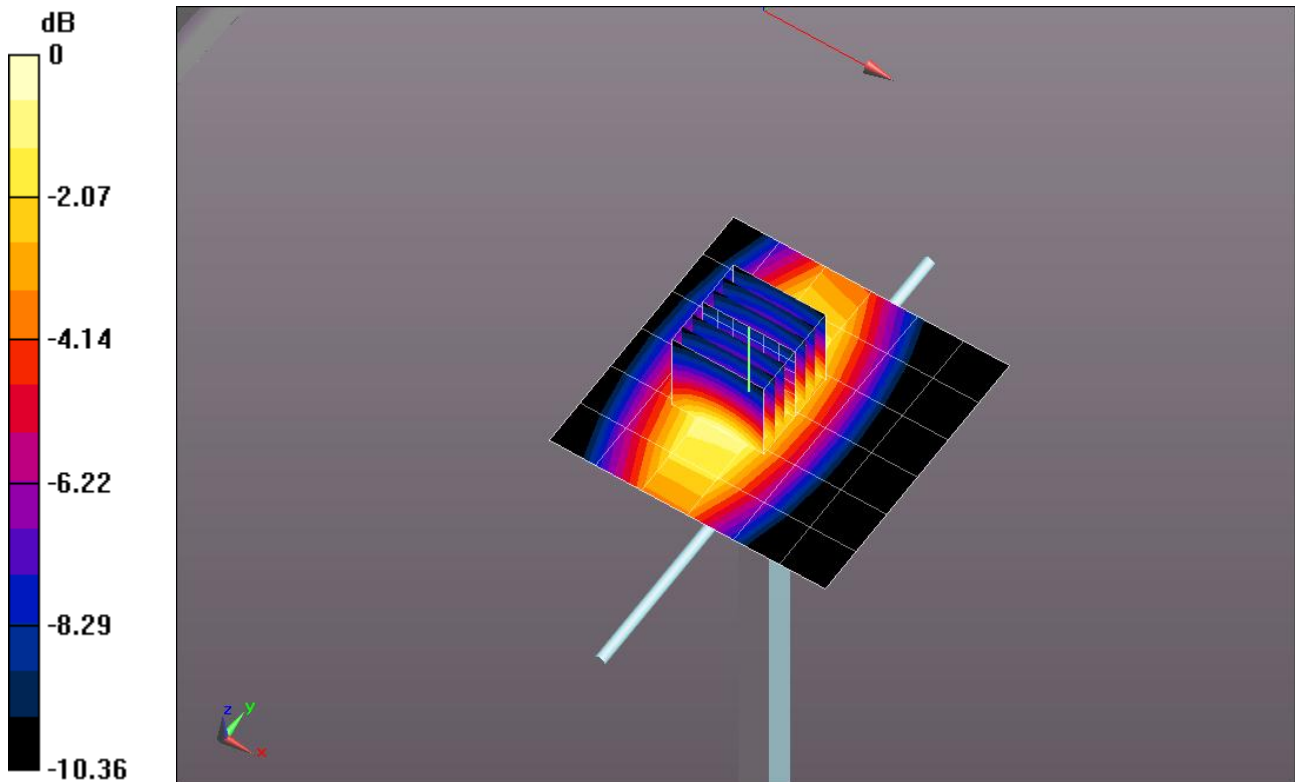

0 dB = 1.200mW/g = 1.58 dB mW/g

20120625_SystemPerformanceCheck-D835V2 SN 4d002

Frequency: 835 MHz; Duty Cycle: 1:1

Body/Pin=100 mW/Z Scan (1x1x21): Measurement grid: dx=20mm, dy=20mm, dz=5mm
Maximum value of SAR (measured) = 0.783 mW/g

