



# SPORTON International Inc.

No. 52, Hwa Ya 1st Rd., Kwei-Shan Hsiang, TaoYuan Hsien, Taiwan, R.O.C.  
Ph: 886-3-327-3456 / FAX: 886-3-327-0973 / www.sporton.com.tw

## FCC RADIO TEST REPORT

Applicant's company	Broadcom Corporation
Applicant Address	190 Mathilda Place, Sunnyvale, CA 94086 USA
FCC ID	QDS-BRCM1067
Manufacturer's company	Hon Hai PRECISION IND. CO., LTD.
Manufacturer Address	5F-1, 5 Hsin-An road Hsinchu, Science-Based Industrial Park, Taiwan, R.O.C.

Product Name	802.11 abgn WLAN + Bluetooth Card
Brand Name	Broadcom
Model Name	BCM94330LGA
Test Rule Part(s)	47 CFR FCC Part 15 Subpart E § 15.407
Test Freq. Range	5150 ~ 5350MHz / 5470 ~ 5725MHz
Received Date	Jun. 04, 2012
Final Test Date	Jul. 16, 2012
Submission Type	Original Equipment

### Statement

Test result included is for the IEEE 802.11n and IEEE 802.11a (5150 ~ 5350MHz / 5470 ~ 5725MHz) of the product.

The test result in this report refers exclusively to the presented test model / sample.

Without written approval of SPORTON International Inc., the test report shall not be reproduced except in full.

The measurements and test results shown in this test report were made in accordance with the procedures and found in compliance with the limit given in ANSI C63.10-2009 and 47 CFR FCC Part 15 Subpart E and KDB 789033 – 20120305.

The test equipment used to perform the test is calibrated and traceable to NML/ROC.



## Table of Contents

<b>1. CERTIFICATE OF COMPLIANCE .....</b>	<b>1</b>
<b>2. SUMMARY OF THE TEST RESULT .....</b>	<b>2</b>
<b>3. GENERAL INFORMATION .....</b>	<b>3</b>
3.1. Product Details .....	3
3.2. Accessories .....	5
3.3. Table for Filed Antenna .....	5
3.4. Table for Carrier Frequencies .....	6
3.5. Table for Test Modes.....	7
3.6. Table for Testing Locations .....	8
3.7. Table for Supporting Units .....	8
3.8. Table for Parameters of Test Software Setting .....	9
3.9. Test Configurations .....	10
<b>4. TEST RESULT .....</b>	<b>13</b>
4.1. AC Power Line Conducted Emissions Measurement .....	13
4.2. 99% Occupied Bandwidth Measurement.....	17
4.3. Maximum Conducted Output Power Measurement .....	30
4.4. Power Spectral Density Measurement.....	34
4.5. Peak Excursion Measurement .....	42
4.6. Radiated Emissions Measurement .....	49
4.7. Band Edge Emissions Measurement.....	73
4.8. Frequency Stability Measurement.....	83
4.9. Antenna Requirements.....	85
<b>5. LIST OF MEASURING EQUIPMENTS .....</b>	<b>86</b>
<b>6. TEST LOCATION.....</b>	<b>88</b>
<b>7. TAF CERTIFICATE OF ACCREDITATION .....</b>	<b>89</b>
<b>APPENDIX A. TEST PHOTOS .....</b>	<b>A1 ~ A5</b>
<b>APPENDIX B. MAXIMUM PERMISSIBLE EXPOSURE .....</b>	<b>B1 ~ B4</b>
<b>APPENDIX C. CO-LOCATION REPORT.....</b>	<b>C1 ~ C3</b>



## History of This Test Report

REPORT NO.	VERSION	DESCRIPTION	ISSUED DATE
FR260412AB	Rev. 01	Initial issue of report	Jul. 25, 2012

## 1. CERTIFICATE OF COMPLIANCE

Product Name : 802.11 abgn WLAN + Bluetooth Card  
Brand Name : Broadcom  
Model Name : BCM94330LGA  
Applicant : Broadcom Corporation  
Test Rule Part(s) : 47 CFR FCC Part 15 Subpart E § 15.407

Sporton International as requested by the applicant to evaluate the EMC performance of the product sample received on Jun. 04, 2012 would like to declare that the tested sample has been evaluated and found to be in compliance with the tested rule parts. The data recorded as well as the test configuration specified is true and accurate for showing the sample's EMC nature.

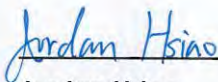

Jordan Hsiao

SPORTON INTERNATIONAL INC.

## 2. SUMMARY OF THE TEST RESULT

Applied Standard: 47 CFR FCC Part 15 Subpart E				
Part	Rule Section	Description of Test	Result	Under Limit
4.1	15.207	AC Power Line Conducted Emissions	Complies	18.49 dB
4.2	15.407(a)	26dB Spectrum Bandwidth	Complies	-
4.3	15.407(a)	Maximum Conducted Output Power	Complies	3.64dB
4.4	15.407(a)	Power Spectral Density	Complies	5.02 dB
4.5	15.407(a)	Peak Excursion	Complies	2.76 dB
4.6	15.407(b)	Radiated Emissions	Complies	2.10 dB
4.7	15.407(b)	Band Edge Emissions	Complies	0.53 dB
4.8	15.407(g)	Frequency Stability	Complies	-
4.9	15.203	Antenna Requirements	Complies	-

Test Items	Uncertainty	Remark
AC Power Line Conducted Emissions	±2.3dB	Confidence levels of 95%
Maximum Conducted Output Power	±0.5dB	Confidence levels of 95%
Power Spectral Density	±0.5dB	Confidence levels of 95%
Peak Excursion	±0.5dB	Confidence levels of 95%
26dB Spectrum Bandwidth / Frequency Stability	±8.5×10 <sup>-8</sup>	Confidence levels of 95%
Radiated Emissions (9kHz~30MHz)	±0.8dB	Confidence levels of 95%
Radiated Emissions (30MHz~1000MHz)	±1.9dB	Confidence levels of 95%
Radiated / Band Edge Emissions (1GHz~18GHz)	±1.9dB	Confidence levels of 95%
Radiated Emissions (18GHz~40GHz)	±1.9dB	Confidence levels of 95%
Temperature	±0.7°C	Confidence levels of 95%
Humidity	±3.2%	Confidence levels of 95%
DC / AC Power Source	±1.4%	Confidence levels of 95%

### 3. GENERAL INFORMATION

#### 3.1. Product Details

##### IEEE 802.11n

Items	Description
Product Type	WLAN (1TX, 1RX)
Radio Type	Intentional Transceiver
Power Type	From host system
Modulation	see the below table for IEEE 802.11n
Data Modulation	OFDM (BPSK / QPSK / 16QAM / 64QAM)
Data Rate (Mbps)	see the below table for IEEE 802.11n
Frequency Range	5150 ~ 5350MHz / 5470 ~ 5725MHz
Channel Number	19 for 20MHz bandwidth
Channel Band Width (99%)	MCS0 (20MHz): 17.60 MHz
Conducted Output Power	Band 1: MCS0 (20MHz): 12.09 dBm Band 2: MCS0 (20MHz): 12.17 dBm Band 3: MCS0 (20MHz): 12.17 dBm
Carrier Frequencies	Please refer to section 3.4
Antenna	Please refer to section 3.3

##### IEEE 802.11a

Items	Description
Product Type	WLAN (1TX, 1RX)
Radio Type	Intentional Transceiver
Power Type	From host system
Modulation	OFDM for IEEE 802.11a
Data Modulation	OFDM (BPSK / QPSK / 16QAM / 64QAM)
Data Rate (Mbps)	OFDM (6/9/12/18/24/36/48/54/108)
Frequency Range	5150 ~ 5350MHz / 5470 ~ 5725MHz
Channel Number	19
Channel Band Width (99%)	11a: 16.64 MHz
Conducted Output Power	Band 1: 13.13 dBm ; Band 2: 13.21 dBm ; Band 3: 13.38 dBm
Carrier Frequencies	Please refer to section 3.4
Antenna	Please refer to section 3.3

**Antenna & Band width**

Antenna	Single (TX)
Band width Mode	20 MHz
IEEE 802.11a	V
IEEE 802.11n	V

**IEEE 802.11n spec**

MCS Index	Nss	Modulation	R	NBPS	NCBPS	NDBPS	Datarate(Mbps)	
							800nsGI	400nsGI
							20MHz	20MHz
0	1	BPSK	1/2	1	52	26	6.5	7.200
1	1	QPSK	1/2	2	104	52	13.0	14.400
2	1	QPSK	3/4	2	104	78	19.5	21.700
3	1	16-QAM	1/2	4	208	104	26.0	28.900
4	1	16-QAM	3/4	4	208	156	39.0	43.300
5	1	64-QAM	2/3	6	312	208	52.0	57.800
6	1	64-QAM	3/4	6	312	234	58.5	65.000
7	1	64-QAM	5/6	6	312	260	65.0	72.200
8	2	BPSK	1/2	1	104	52	13.0	14.444
9	2	QPSK	1/2	2	208	104	26.0	28.889
10	2	QPSK	3/4	2	208	156	39.0	43.333
11	2	16-QAM	1/2	4	416	208	52.0	57.778
12	2	16-QAM	3/4	4	416	312	78.0	86.667
13	2	64-QAM	2/3	6	624	416	104.0	115.556
14	2	64-QAM	3/4	6	624	468	117.0	130.000
15	2	64-QAM	5/6	6	624	520	130.0	144.444

Symbol	Explanation
NSS	Number of spatial streams
R	Code rate
NBPS	Number of coded bits per single carrier
NCBPS	Number of coded bits per symbol
NDBPS	Number of data bits per symbol
GI	guard interval

### 3.2. Accessories

NA

### 3.3. Table for Filed Antenna

Ant.	Brand	Model Name	Antenna Type	Connector	Gain (dBi)	
A	WhaYu	-	PIFA Antenna	I-pex	2.4GHz	3
B	WhaYu	-	PIFA Antenna	I-pex	5GHz	4.3

Note: The EUT has two antennas. One for 2.4GHz band use, the other for 5GHz band use.

<5GHz WALN function>

For IEEE 802.11 a/n Mode: (1TX, 1RX)

Only Ant. B can be used as transmitting/receiving antenna.

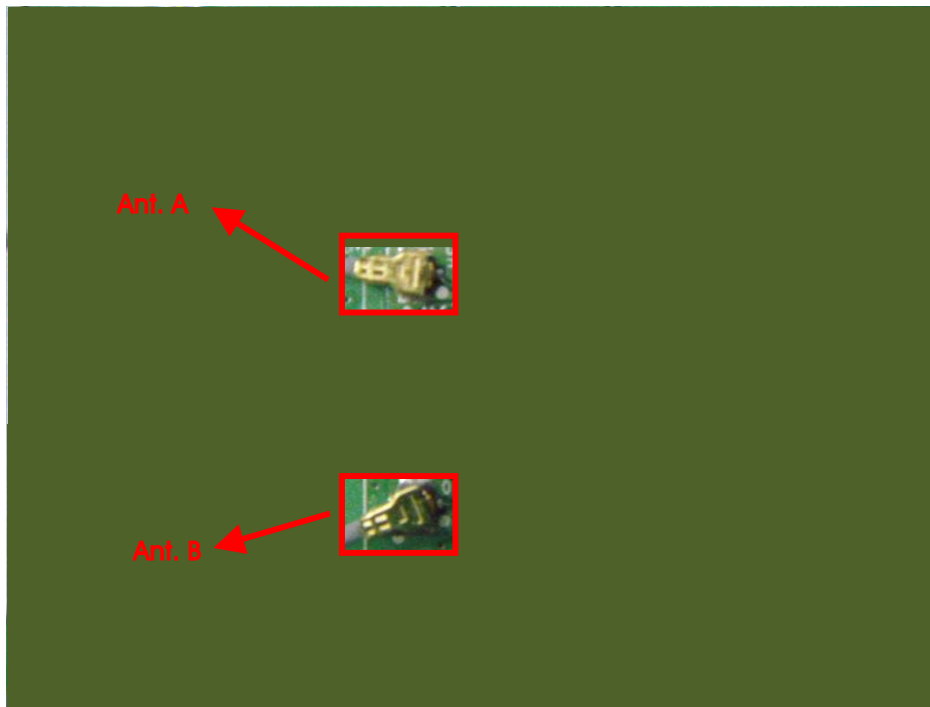



### 3.4. Table for Carrier Frequencies

For IEEE 802.11a, use Channel 36, 40, 44, 48, 52, 56, 60, 64, 100, 104, 108, 112, 116, 132, 136, 140.

There is one bandwidth systems for IEEE 802.11n.

For both 20MHz bandwidth systems, use Channel 36, 40, 44, 48, 52, 56, 60, 64, 100, 104, 108, 112, 116, 132, 136, 140.

Frequency Band	Channel No.	Frequency	Channel No.	Frequency
5150~5250 MHz Band 1	36	5180 MHz	44	5220 MHz
	40	5200 MHz	48	5240 MHz
5250~5350 MHz Band 2	52	5260 MHz	60	5300 MHz
	56	5280 MHz	64	5320 MHz
5470~5725 MHz Band 3	100	5500 MHz	116	5580 MHz
	104	5520 MHz	132	5660 MHz
	108	5540 MHz	136	5680 MHz
	112	5560 MHz	140	5700 MHz

### 3.5. Table for Test Modes

Preliminary tests were performed in different data rate to find the worst radiated emission. The data rate shown in the table below is the worst-case rate with respect to the specific test item. Investigation has been done on all the possible configurations for searching the worst cases. The following table is a list of the test modes shown in this test report.

Test Items	Mode		Data Rate	Channel	Antenna
AC Power Conducted Emission	Normal Link		Auto	-	-
Max. Conducted Output Power	MCS0/20MHz	Band 1~2	6.5Mbps	36/40/48/52/60/64	B
		Band 3	6.5Mbps	100/116/140	B
Power Spectral Density	11a/BPSK	Band 1~2	6Mbps	36/40/48/52/60/64	B
		Band 3	6Mbps	100/116/140	B
26dB Spectrum Bandwidth	MCS0/20MHz	Band 1~2	6.5Mbps	36/40/48/52/60/64	B
		Band 3	6.5Mbps	100/116/140	B
99% Occupied Bandwidth Measurement	11a/BPSK	Band 1~2	6Mbps	36/40/48/52/60/64	B
		Band 3	6Mbps	100/116/140	B
Peak Excursion					
Radiated Emission Below 1GHz	Normal Link		Auto	-	-
Radiated Emission Above 1GHz	MCS0/20MHz	Band 1~2	6.5Mbps	36/40/48/52/60/64	B
		Band 3	6.5Mbps	100/116/140	B
	11a/BPSK	Band 1~2	6Mbps	36/40/48/52/60/64	B
		Band 3	6Mbps	100/116/140	B
Band Edge Emission	MCS0/20MHz	Band 1~2	6.5Mbps	36/40/48/52/60/64	B
		Band 3	6.5Mbps	100/116/140	B
	11a/BPSK	Band 1~2	6Mbps	36/40/48/52/60/64	B
		Band 3	6Mbps	100/116/140	B
Frequency Stability	Un-modulation		-	40/60	N/A

### 3.6. Table for Testing Locations

Test Site No.	Site Category	Location	FCC Reg. No.	IC File No.	VCCI Reg. No
03CH01-CB	SAC	Hsin Chu	262045	IC 4086D	-
CO01-CB	Conduction	Hsin Chu	262045	IC 4086D	-
TH01-CB	OVEN Room	Hsin Chu	-	-	-

Open Area Test Site (OATS); Semi Anechoic Chamber (SAC); Fully Anechoic Chamber (FAC).

Please refer section 6 for Test Site Address.

### 3.7. Table for Supporting Units

Support Unit	Brand	Model	FCC ID
Notebook	DELL	M1330	E2K4965AGNM
Notebook	DELL	LATITUDE E6500	PDN:5JNCT A00
Mouse	Logitech M90	M-U0026	DoC
Wireless AP	BELKIN	WG7016G22-LF-AK	DoC
EARPHONES	E-books	E-EPC040	N/A

### 3.8. Table for Parameters of Test Software Setting

During testing, Channel & Power Controlling Software provided by the customer was used to control the operating channel as well as the output power level. The RF output power selection is for the setting of RF output power expected by the customer and is going to be fixed on the firmware of the final end product.

#### Power Parameters of IEEE 802.11n MCS0 20MHz

Test Software Version	DOS								
Frequency	5180 MHz	5200 MHz	5240 MHz	5260 MHz	5300 MHz	5320 MHz	5500 MHz	5580 MHz	5700 MHz
Ant. B	52.00	52.00	52.00	52.00	52.00	52.00	46.00	46.00	48.00

#### Power Parameters of IEEE 802.11a

Test Software Version	DOS								
Frequency	5180 MHz	5200 MHz	5240 MHz	5260 MHz	5300 MHz	5320 MHz	5500 MHz	5580 MHz	5700 MHz
Ant. B	56.00	56.00	56.00	56.00	56.00	56.00	50.00	50.00	54.00

During the test, "DOS" under WIN XP was executed the test program to control the EUT continuously transmit RF signal.

### 3.9. Test Configurations

#### 3.9.1. Radiation Emissions Test Configuration

Test Configuration: 30MHz ~ 1GHz

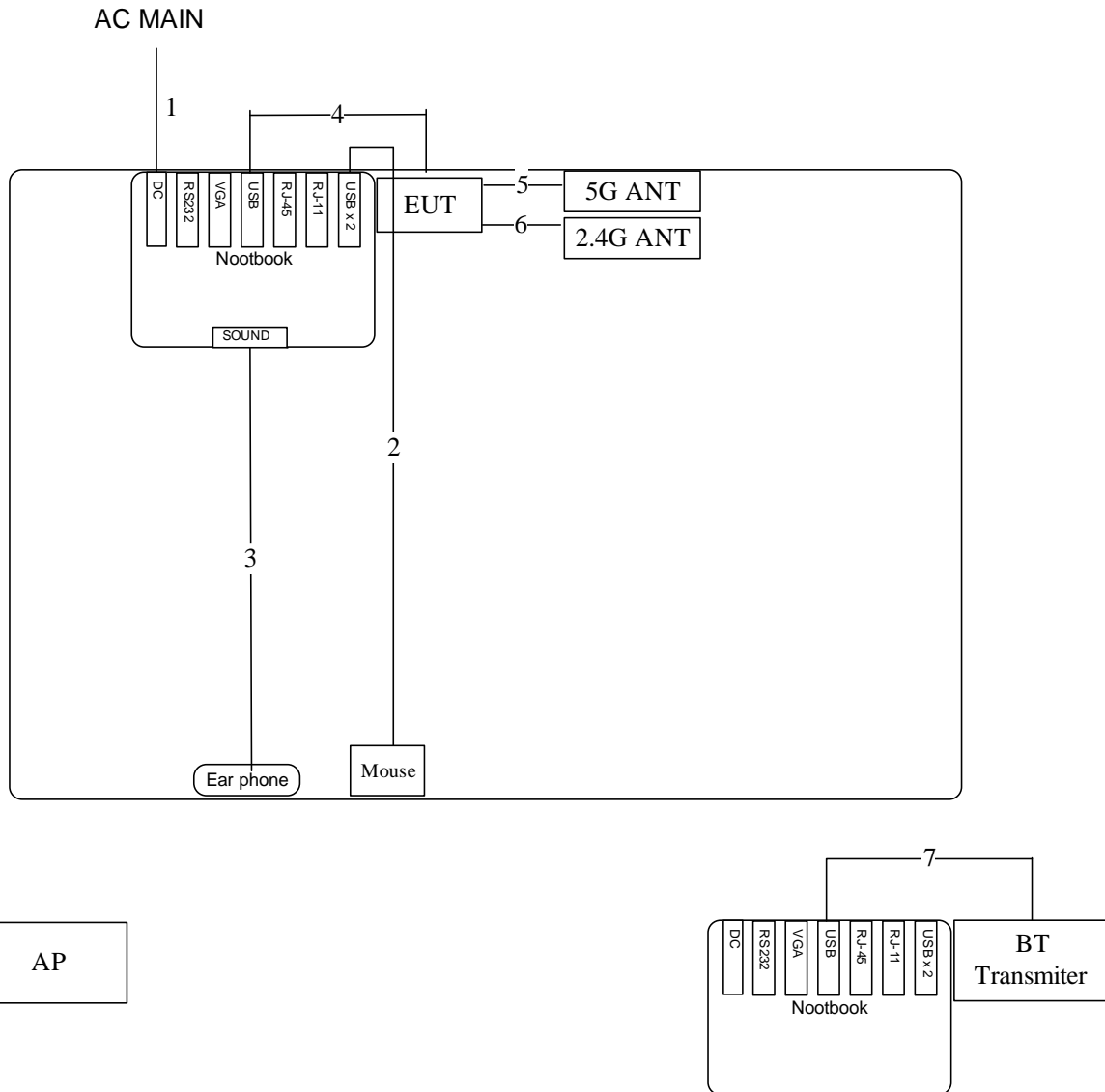

Item	Connection	Shield	Length
1	Power cable	No	2.6M
2	USB cable	No	1.8M
3	Earphone cable	No	1.1M
4	RS-232 cable	Yes	1.95M
5	Antenna cable	Yes	0.11M
6	Antenna cable	Yes	1.8M
7	RS-232 cable	Yes	1.95M

Test Configuration: above 1GHz

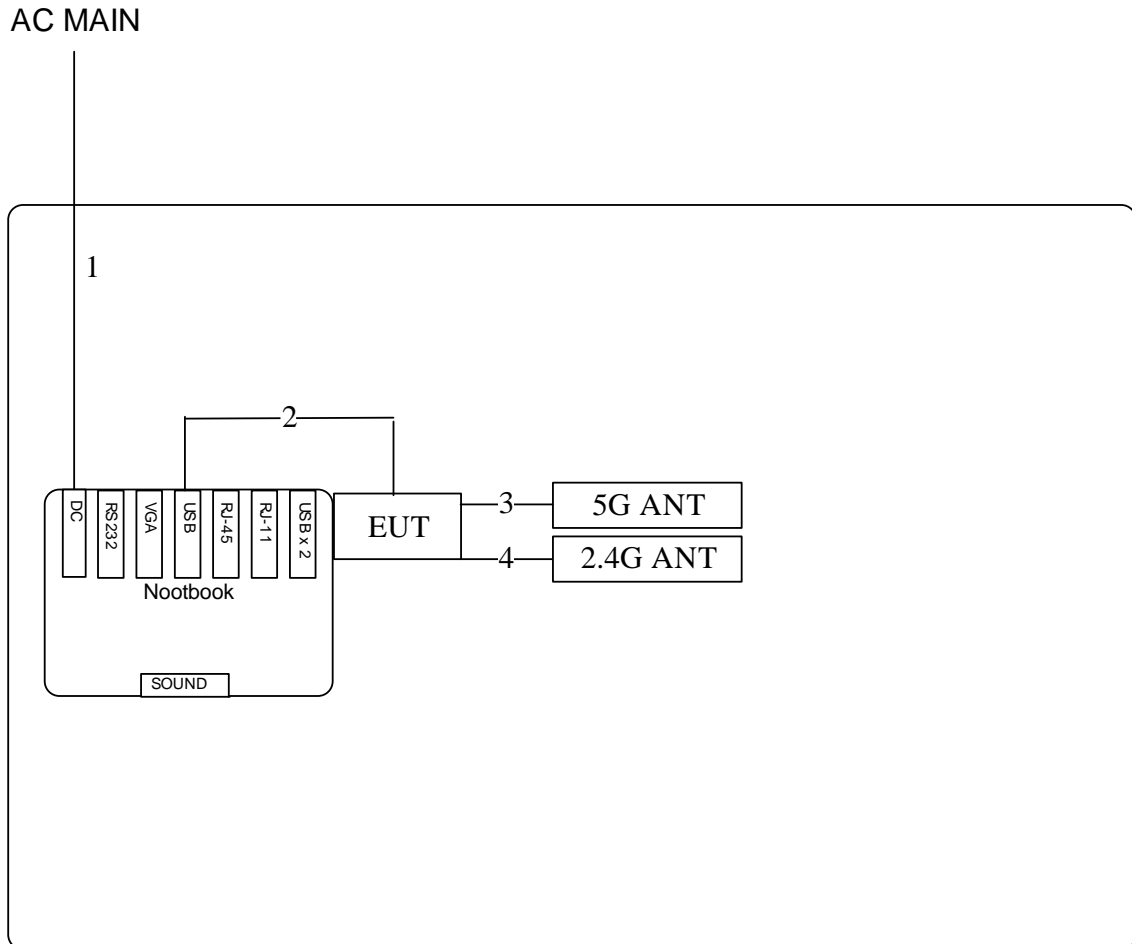

Item	Connection	Shield	Length
1	Power cable	No	2.6M
2	Antenna cable	Yes	0.11M
3	Antenna cable	Yes	1.8M
4	RS-232 cable	Yes	1.95M

### 3.9.2. AC Power Line Conduction Emissions Test Configuration

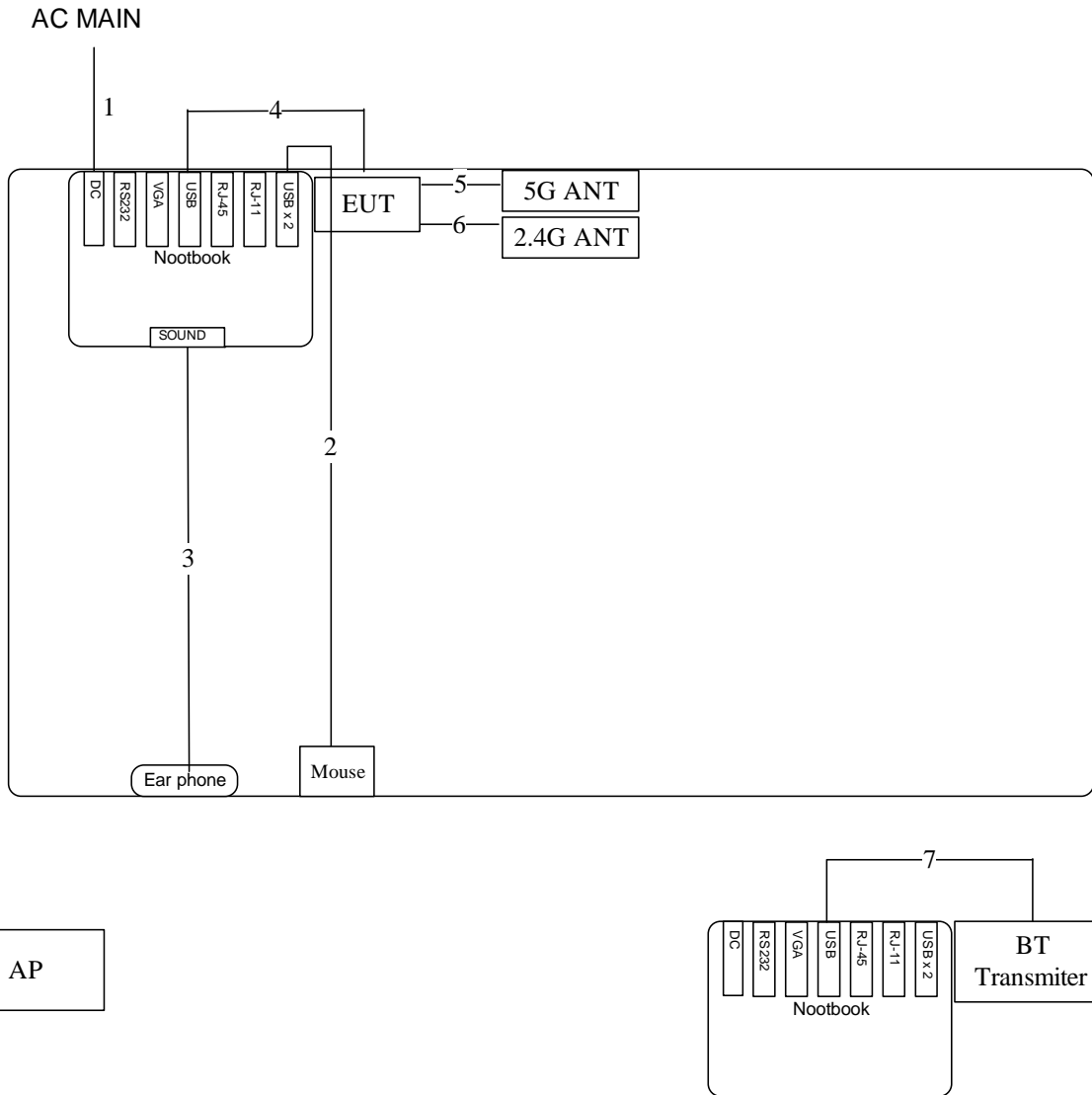

Item	Connection	Shield	Length
1	Power cable	No	2.6M
2	USB cable	No	1.8M
3	Earphone cable	No	1.1M
4	RS-232 cable	Yes	1.95M
5	Antenna cable	Yes	0.11M
6	Antenna cable	Yes	1.8M
7	RS-232 cable	Yes	1.95M

## 4. TEST RESULT

### 4.1. AC Power Line Conducted Emissions Measurement

#### 4.1.1. Limit

For this product that is designed to connect to the AC power line, the radio frequency voltage that is conducted back onto the AC power line on any frequency or frequencies within the band 150 kHz to 30 MHz shall not exceed below limits table.

Frequency (MHz)	QP Limit (dBuV)	AV Limit (dBuV)
0.15~0.5	66~56	56~46
0.5~5	56	46
5~30	60	50

#### 4.1.2. Measuring Instruments and Setting

Please refer to section 5 of equipments list in this report. The following table is the setting of the receiver.

Receiver Parameters	Setting
Attenuation	10 dB
Start Frequency	0.15 MHz
Stop Frequency	30 MHz
IF Bandwidth	9 KHz

#### 4.1.3. Test Procedures

1. Configure the EUT according to ANSI C63.10. The EUT or host of EUT has to be placed 0.4 meter far from the conducting wall of the shielding room and at least 80 centimeters from any other grounded conducting surface.
2. Connect EUT or host of EUT to the power mains through a line impedance stabilization network (LISN).
3. All the support units are connected to the other LISNs. The LISN should provide 50uH/50ohms coupling impedance.
4. The frequency range from 150 KHz to 30 MHz was searched.
5. Set the test-receiver system to Peak Detect Function and Specified Bandwidth with Maximum Hold Mode.
6. The measurement has to be done between each power line and ground at the power terminal.



#### 4.1.4. Test Setup Layout

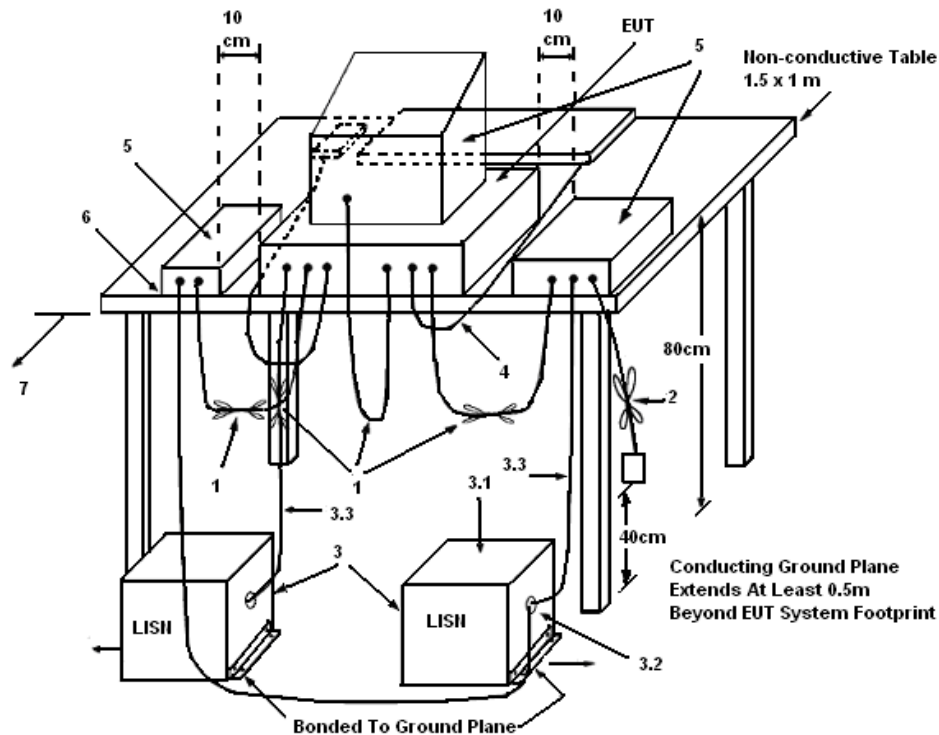

#### LEGEND:

- (1) Interconnecting cables that hang closer than 40 cm to the ground plane shall be folded back and forth in the center forming a bundle 30 to 40 cm long.
- (2) I/O cables that are not connected to a peripheral shall be bundled in the center. The end of the cable may be terminated, if required, using the correct terminating impedance. The overall length shall not exceed 1 m.
- (3) EUT connected to one LISN. Unused LISN measuring port connectors shall be terminated in 50  $\Omega$ . LISN can be placed on top of, or immediately beneath, reference ground plane.
  - (3.1) All other equipment powered from additional LISN(s).
  - (3.2) Multiple outlet strip can be used for multiple power cords of non-EUT equipment.
  - (3.3) LISN at least 80 cm from nearest part of EUT chassis.
- (4) Cables of hand-operated devices, such as keyboards, mice, etc., shall be placed as for normal use.
- (5) Non-EUT components of EUT system being tested.
- (6) Rear of EUT, including peripherals, shall all be aligned and flush with rear of tabletop.
- (7) Rear of tabletop shall be 40 cm removed from a vertical conducting plane that is bonded to the ground plane.

#### 4.1.5. Test Deviation

There is no deviation with the original standard.

#### 4.1.6. EUT Operation during Test

The EUT was placed on the test table and programmed in normal function.

4.1.7. Results of AC Power Line Conducted Emissions Measurement

Temperature	22°C	Humidity	57%
Test Engineer	Kane Liu	Phase	Line
Configuration	Normal Link		

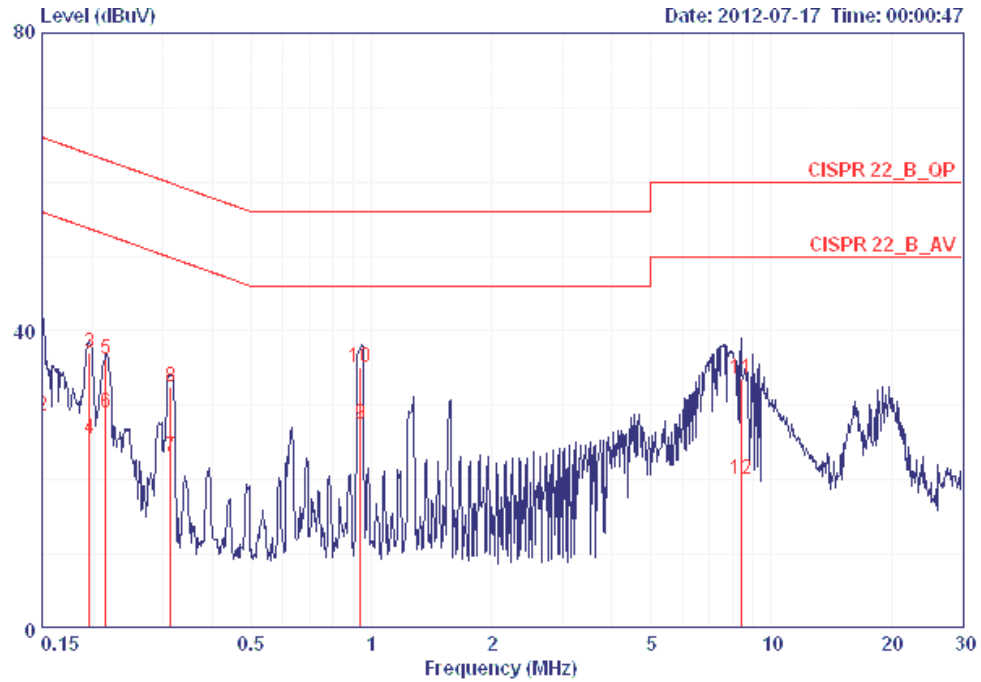

	Freq	Level	Over Limit	Limit Line	Read Level	LISN Factor	Cable Loss	Pol/Phase	Remark
	MHz	dBuV	dB	dBuV	dBuV	dB	dB		
1	0.15000	39.38	-26.62	66.00	39.02	0.16	0.20	LINE	QP
2	0.15000	28.47	-27.53	56.00	28.11	0.16	0.20	LINE	AVERAGE
3	0.19758	36.95	-26.76	63.71	36.60	0.15	0.20	LINE	QP
4	0.19758	25.45	-28.26	53.71	25.10	0.15	0.20	LINE	AVERAGE
5	0.21620	36.23	-26.73	62.96	35.88	0.15	0.20	LINE	QP
6	0.21620	28.93	-24.03	52.96	28.58	0.15	0.20	LINE	AVERAGE
7	0.31495	23.15	-26.69	49.84	22.80	0.15	0.20	LINE	AVERAGE
8	0.31495	32.58	-27.26	59.84	32.23	0.15	0.20	LINE	QP
9	0.94009	27.51	-18.49	46.00	27.14	0.17	0.20	LINE	AVERAGE
10	0.94009	35.20	-20.80	56.00	34.83	0.17	0.20	LINE	QP
11	8.412	33.56	-26.44	60.00	32.93	0.31	0.32	LINE	QP
12	8.412	20.08	-29.92	50.00	19.45	0.31	0.32	LINE	AVERAGE

Temperature	22°C	Humidity	57%
Test Engineer	Kane Liu	Phase	Neutral
Configuration	Normal Link		

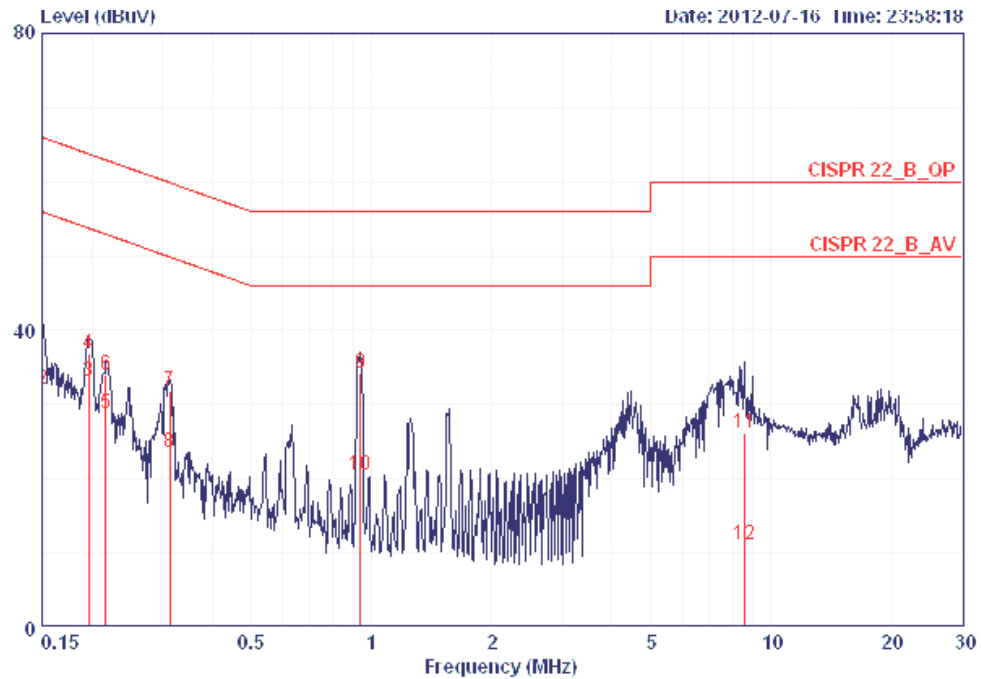

	Freq	Level	Over Limit	Limit Line	Read Level	LISN Factor	Cable Loss	Pol/Phase	Remark
	MHz	dBuV	dB	dBuV	dBuV	dB	dB		
1	0.15000	38.47	-27.53	66.00	38.19	0.08	0.20	NEUTRAL	QP
2	0.15000	32.00	-24.00	56.00	31.72	0.08	0.20	NEUTRAL	AVERAGE
3	0.19654	33.16	-20.60	53.76	32.88	0.08	0.20	NEUTRAL	AVERAGE
4	0.19654	36.82	-26.94	63.76	36.54	0.08	0.20	NEUTRAL	QP
5	0.21620	28.77	-24.19	52.96	28.49	0.08	0.20	NEUTRAL	AVERAGE
6	0.21620	33.94	-29.02	62.96	33.66	0.08	0.20	NEUTRAL	QP
7	0.31328	31.88	-28.00	59.88	31.60	0.08	0.20	NEUTRAL	QP
8	0.31328	23.63	-26.25	49.88	23.35	0.08	0.20	NEUTRAL	AVERAGE
9	0.93810	34.19	-21.81	56.00	33.90	0.09	0.20	NEUTRAL	QP
10	0.93810	20.51	-25.49	46.00	20.22	0.09	0.20	NEUTRAL	AVERAGE
11	8.546	26.19	-33.81	60.00	25.68	0.21	0.30	NEUTRAL	QP
12	8.546	11.19	-38.81	50.00	10.68	0.21	0.30	NEUTRAL	AVERAGE

Note:

Level = Read Level + LISN Factor + Cable Loss.

## 4.2. 99% Occupied Bandwidth Measurement

### 4.2.1. Limit

No restriction limits. But resolution bandwidth within band edge measurement is 1% of the 99% occupied bandwidth.

### 4.2.2. Measuring Instruments and Setting

Please refer to section 5 of equipments list in this report. The following table is the setting of the spectrum analyzer.

Spectrum Parameters	Setting
Attenuation	Auto
Span Frequency	> 26dB Bandwidth
RB	300 kHz
VB	1000 kHz
Detector	Peak
Trace	Max Hold
Sweep Time	Auto

### 4.2.3. Test Procedures

1. The transmitter output (antenna port) was connected to the spectrum analyzer in peak hold mode.
2. The resolution bandwidth of 300 kHz and the video bandwidth of 1000 kHz were used.
3. Measured the spectrum width with power higher than 26dB below carrier.

### 4.2.4. Test Setup Layout

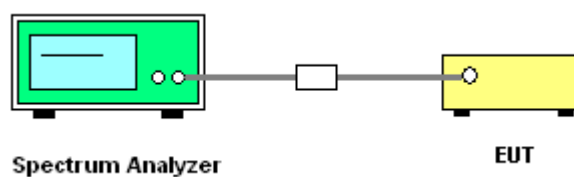

### 4.2.5. Test Deviation

There is no deviation with the original standard.

### 4.2.6. EUT Operation during Test

The EUT was programmed to be in continuously transmitting mode.

#### 4.2.7. Test Result of 99% Occupied Bandwidth

<b>Temperature</b>	24°C	<b>Humidity</b>	63%
<b>Test Engineer</b>	Satoshi Yang	<b>Configurations</b>	IEEE 802.11n

#### Configuration IEEE 802.11n MCS0 20MHz / Ant. B

Channel	Frequency	26dB Bandwidth (MHz)	99% Occupied Bandwidth (MHz)
36	5180 MHz	19.52	17.60
40	5200 MHz	19.36	17.60
48	5240 MHz	19.20	17.60
52	5260 MHz	19.20	17.60
60	5300 MHz	19.36	17.60
64	5320 MHz	19.36	17.60
100	5500 MHz	19.36	17.60
116	5580 MHz	19.36	17.60
140	5700 MHz	19.20	17.60

<b>Temperature</b>	24°C	<b>Humidity</b>	63%
<b>Test Engineer</b>	Satoshi Yang	<b>Configurations</b>	IEEE 802.11a

**Configuration IEEE 802.11a / Ant. B**

Channel	Frequency	26dB Bandwidth (MHz)	99% Occupied Bandwidth (MHz)
36	5180 MHz	19.04	16.64
40	5200 MHz	18.72	16.64
48	5240 MHz	18.72	16.64
52	5260 MHz	19.20	16.64
60	5300 MHz	18.88	16.64
64	5320 MHz	18.88	16.64
100	5500 MHz	18.88	16.64
116	5580 MHz	18.88	16.64
140	5700 MHz	19.52	16.64

26 dB Bandwidth Plot on Configuration IEEE 802.11n MCS0 20MHz / Ant. B / 5180 MHz

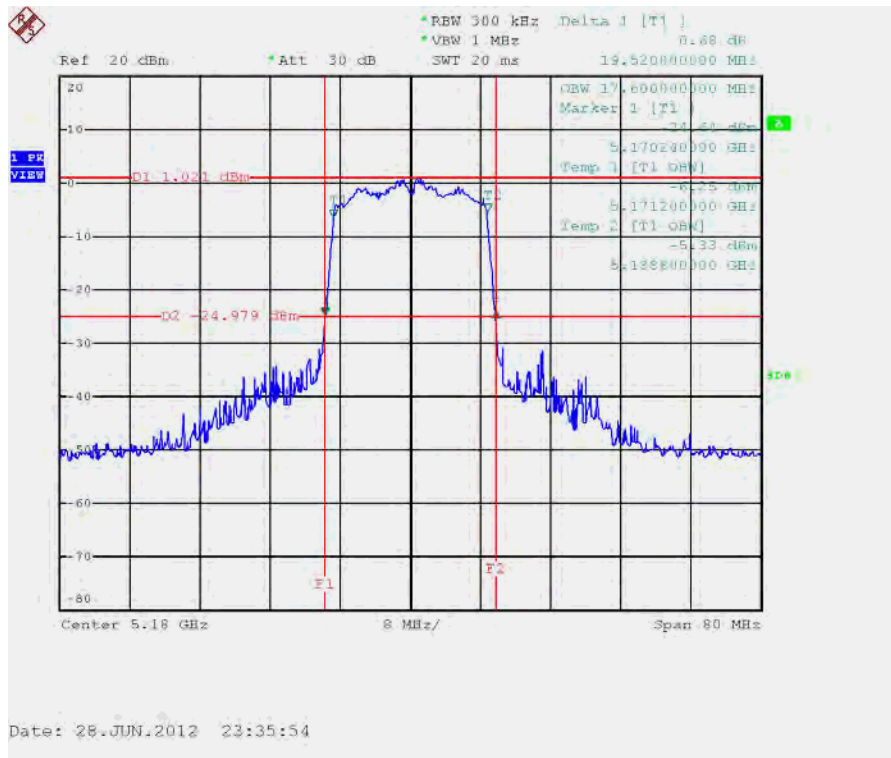

26 dB Bandwidth Plot on Configuration IEEE 802.11n MCS0 20MHz / Ant. B / 5200 MHz

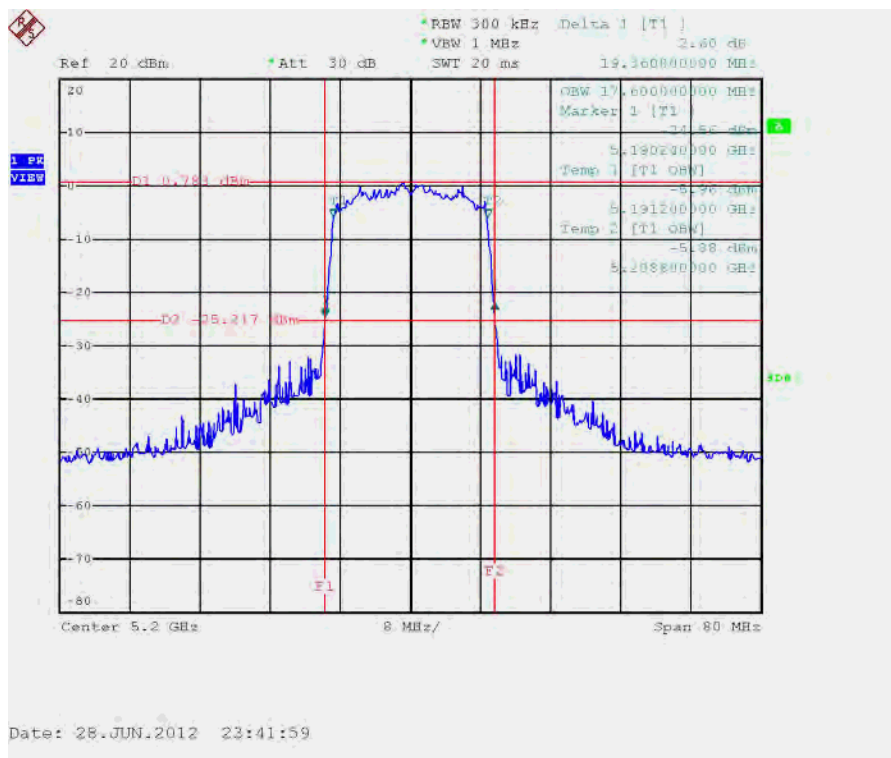

26 dB Bandwidth Plot on Configuration IEEE 802.11n MCS0 20MHz / Ant. B / 5240 MHz

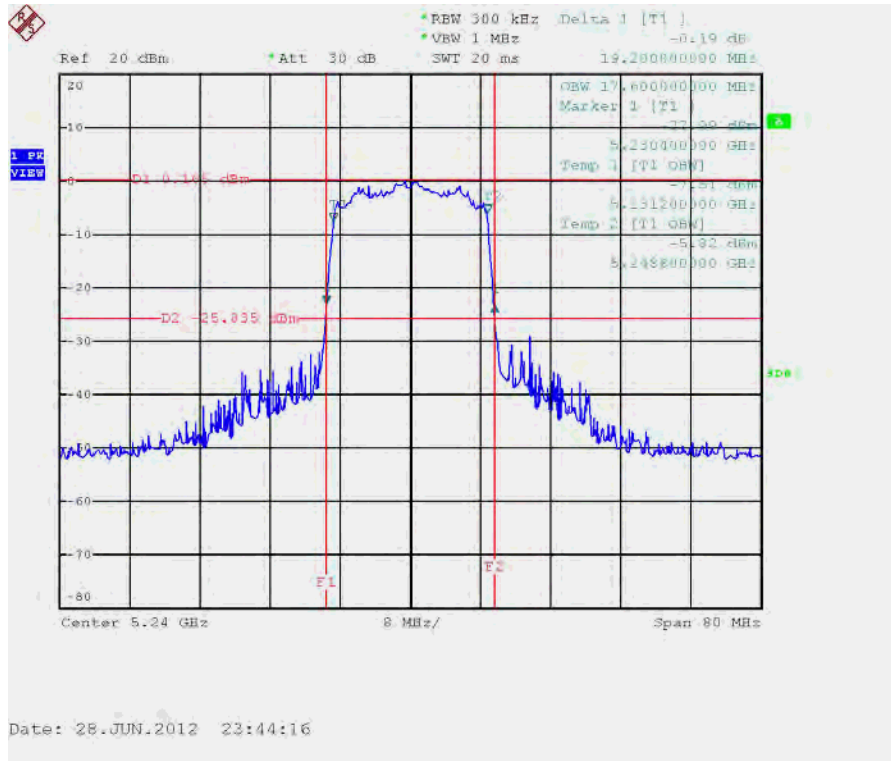

26 dB Bandwidth Plot on Configuration IEEE 802.11n MCS0 20MHz / Ant. B / 5260 MHz

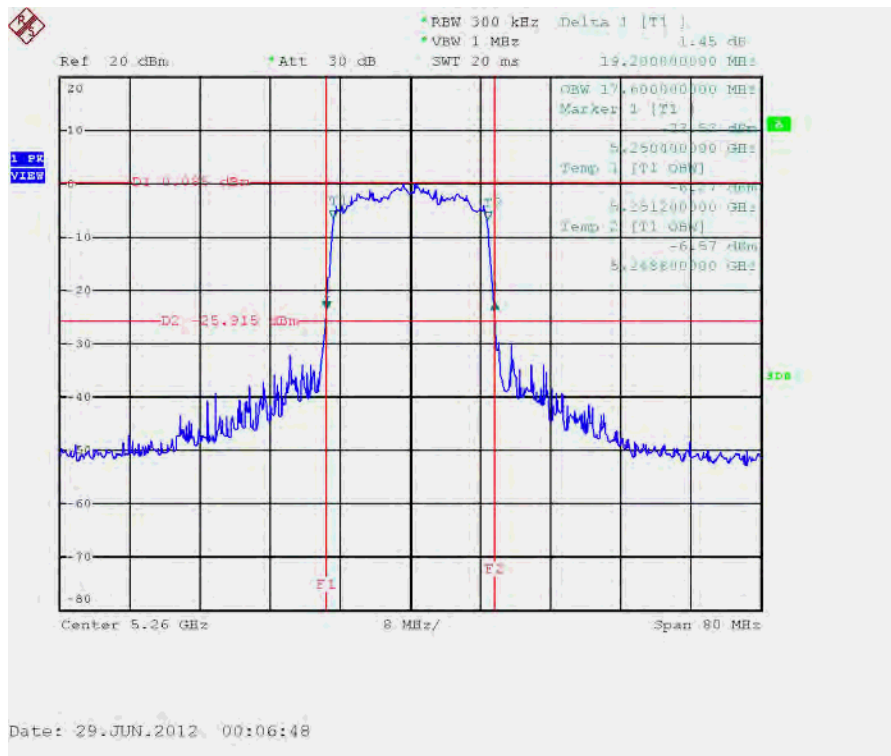



26 dB Bandwidth Plot on Configuration IEEE 802.11n MCS0 20MHz / Ant. B / 5300 MHz

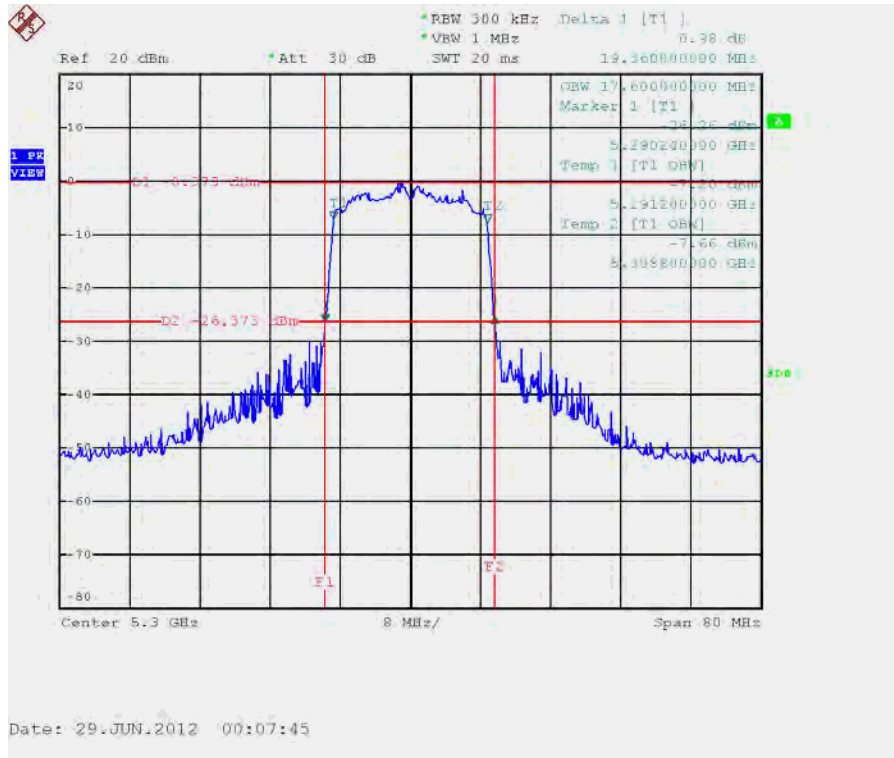

26 dB Bandwidth Plot on Configuration IEEE 802.11n MCS0 20MHz / Ant. B / 5320 MHz

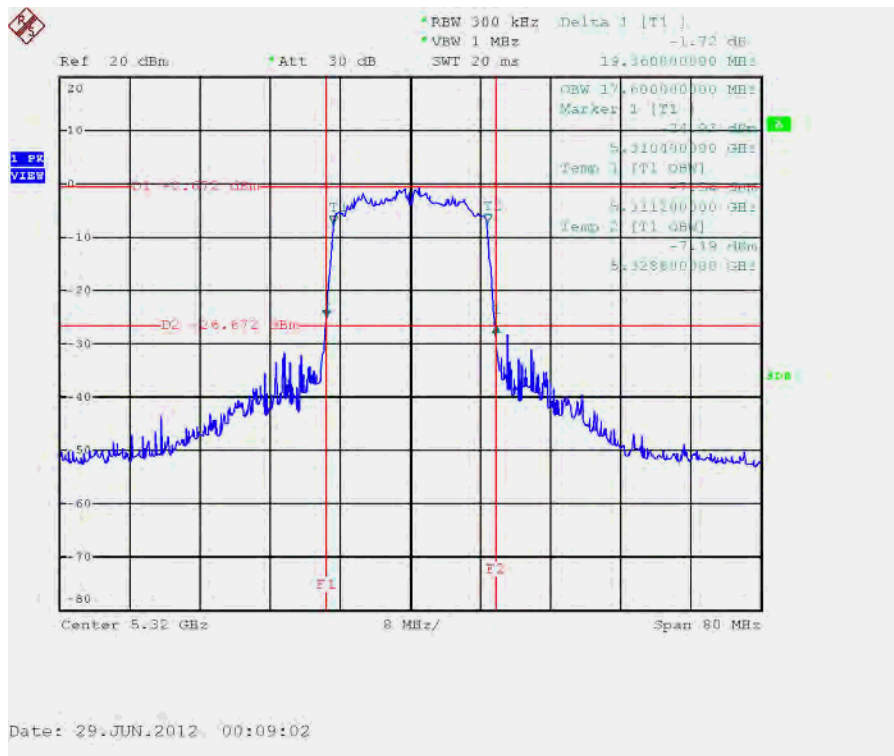

26 dB Bandwidth Plot on Configuration IEEE 802.11n MCS0 20MHz / Ant. B / 5500 MHz

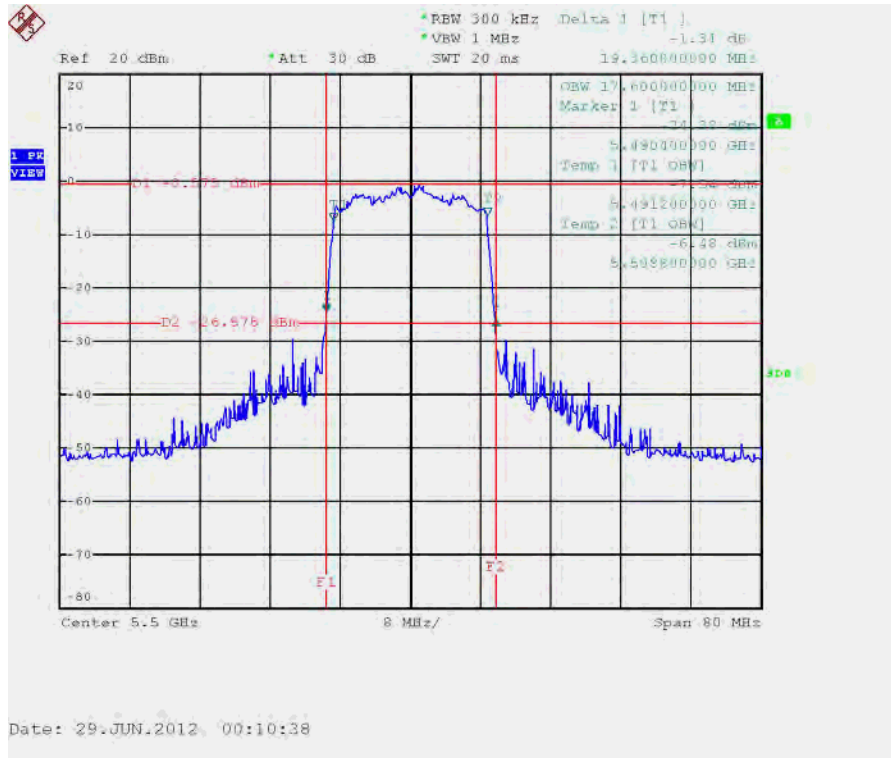

26 dB Bandwidth Plot on Configuration IEEE 802.11n MCS0 20MHz / Ant. B / 5580 MHz

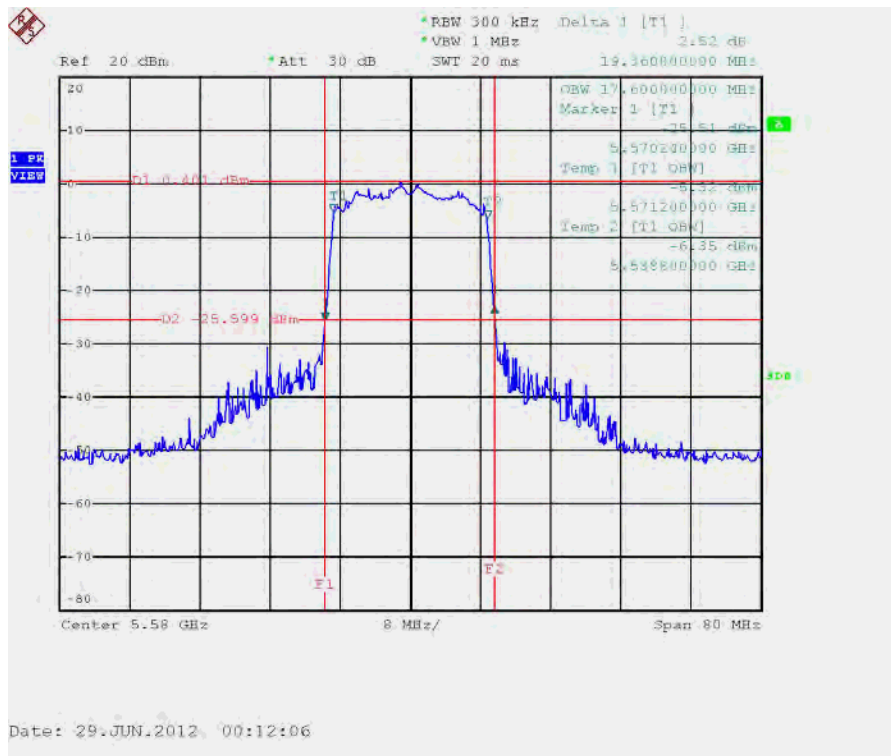

26 dB Bandwidth Plot on Configuration IEEE 802.11n MCS0 20MHz / Ant. B / 5700 MHz

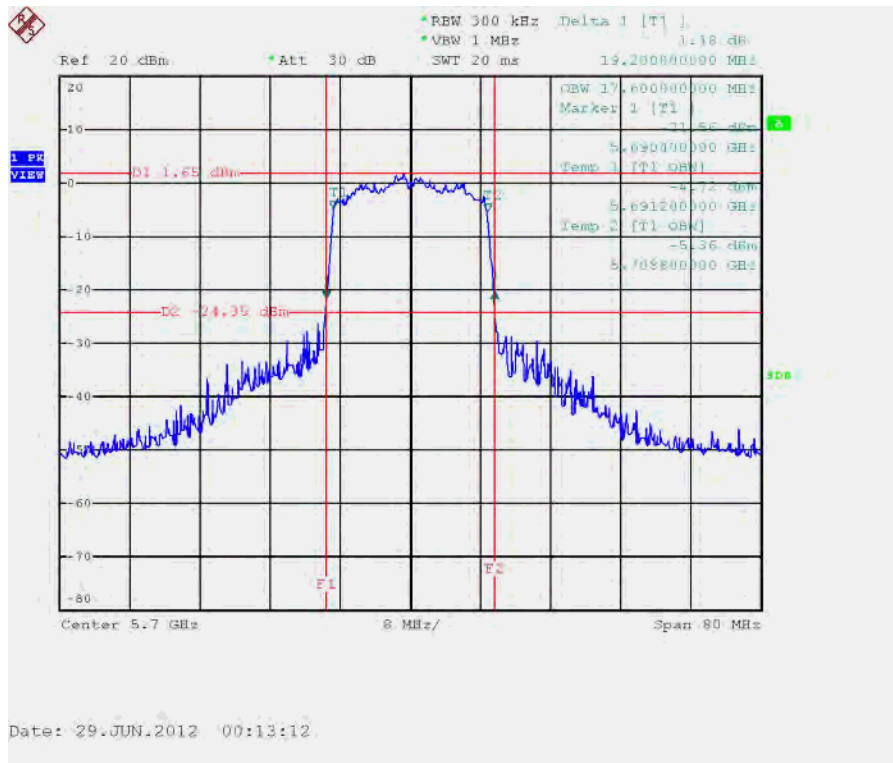

26 dB Bandwidth Plot on Configuration IEEE 802.11a / Ant. B / 5180 MHz

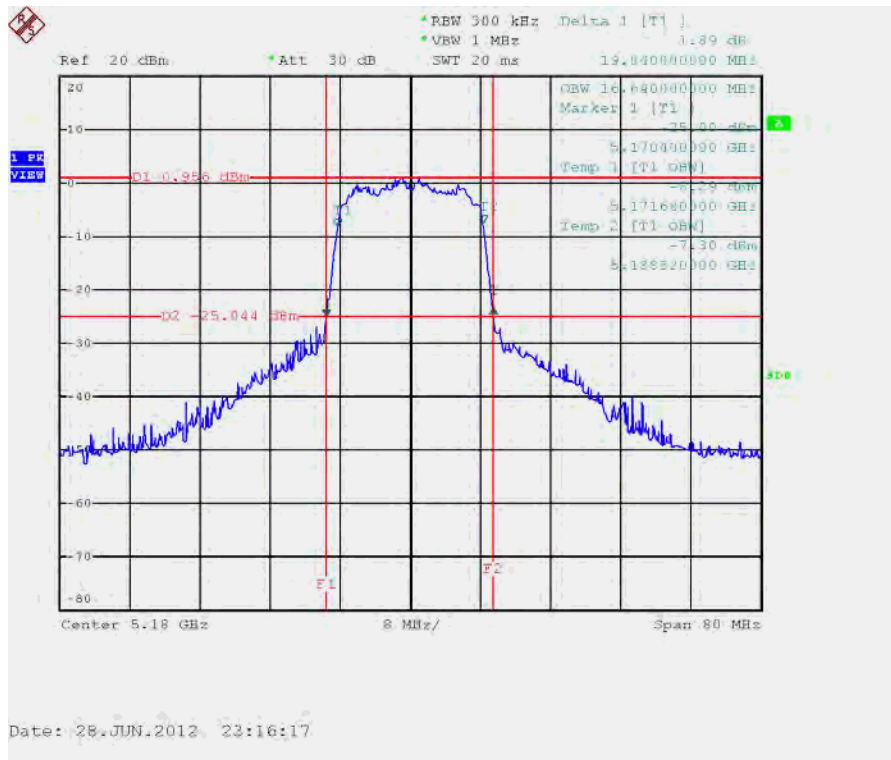

26 dB Bandwidth Plot on Configuration IEEE 802.11a / Ant. B / 5200 MHz

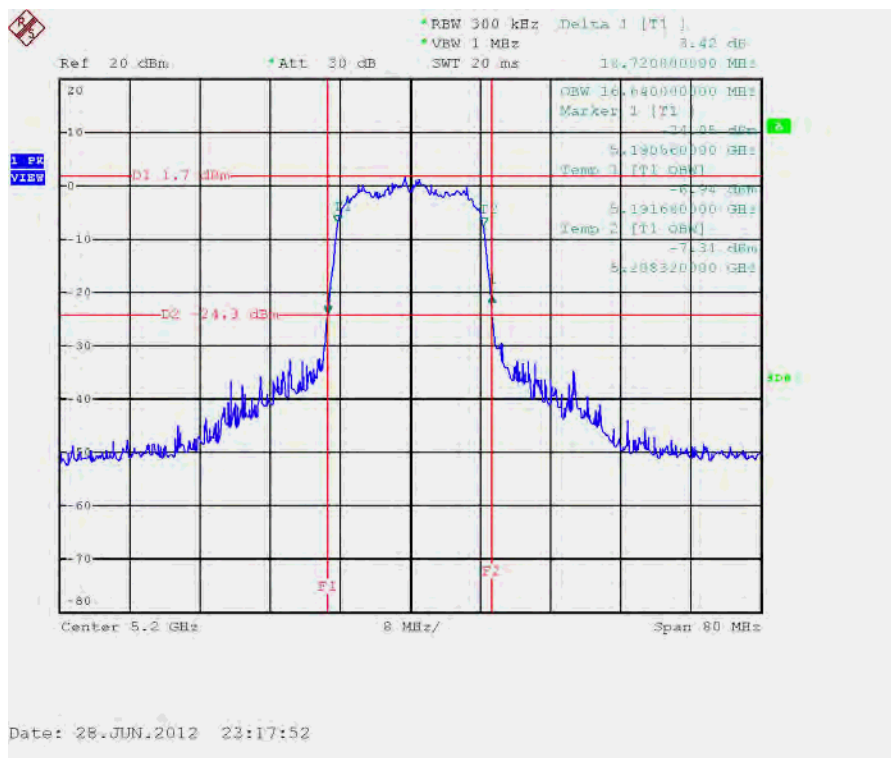

26 dB Bandwidth Plot on Configuration IEEE 802.11a / Ant. B / 5240 MHz

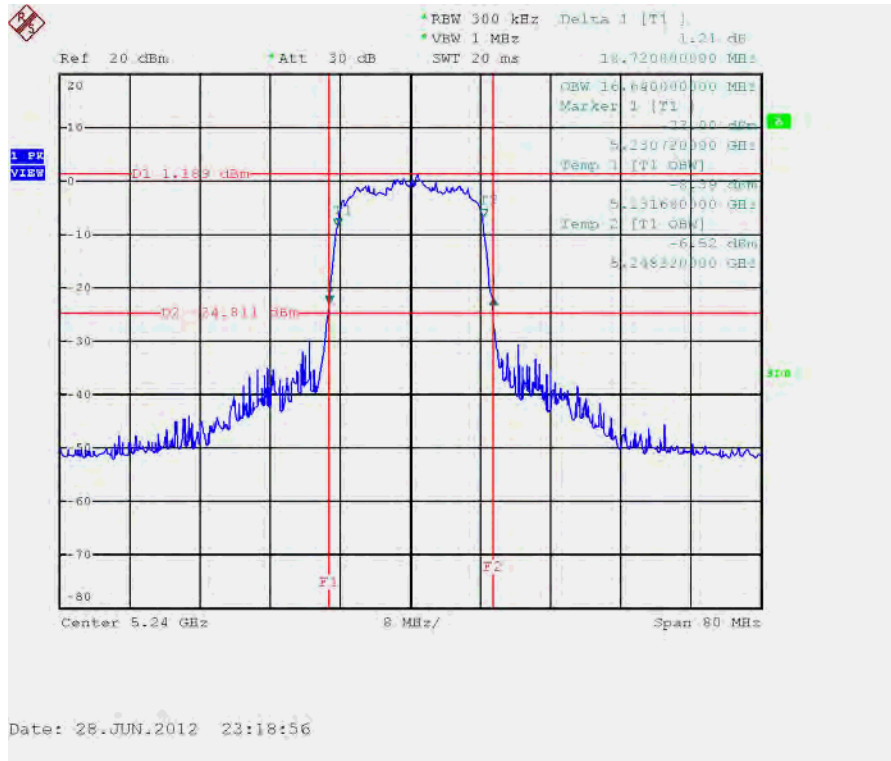

26 dB Bandwidth Plot on Configuration IEEE 802.11a / Ant. B / 5260 MHz

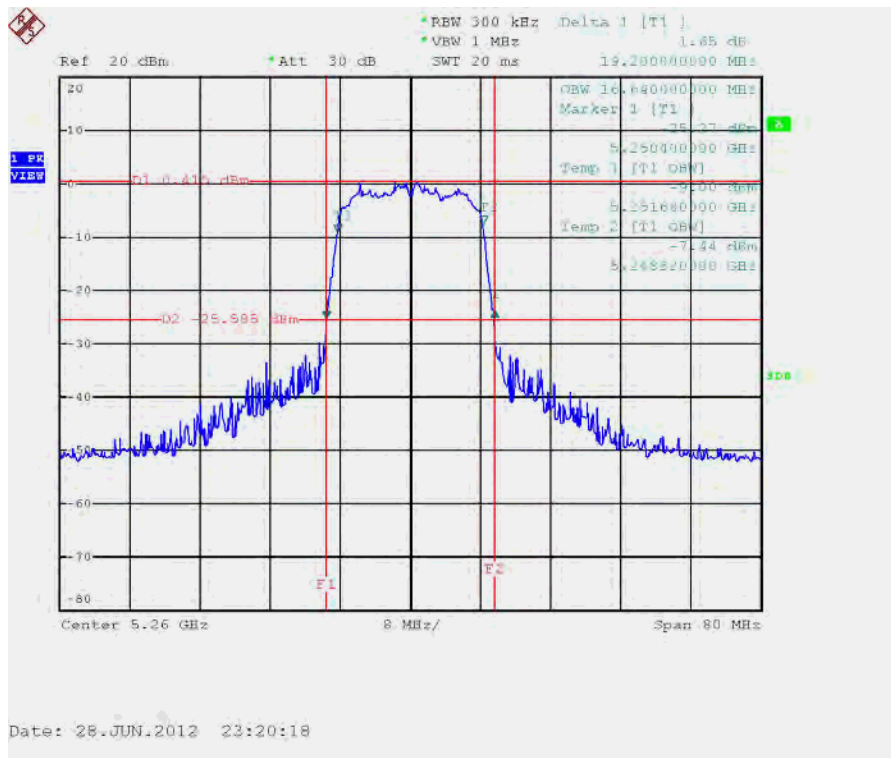

26 dB Bandwidth Plot on Configuration IEEE 802.11a / Ant. B / 5300 MHz

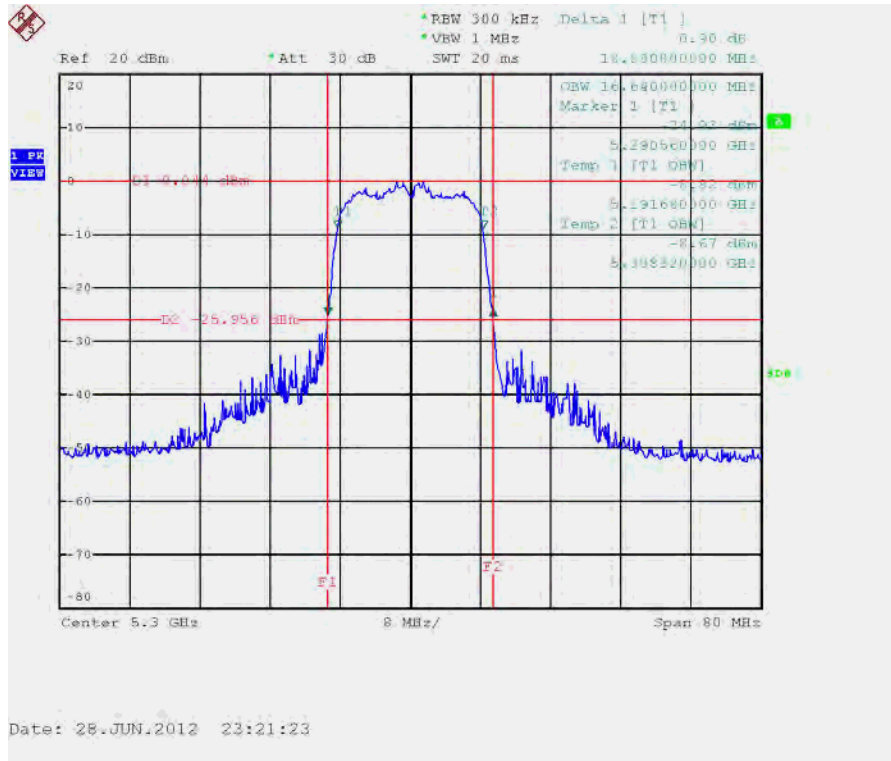

26 dB Bandwidth Plot on Configuration IEEE 802.11a / Ant. B / 5320 MHz

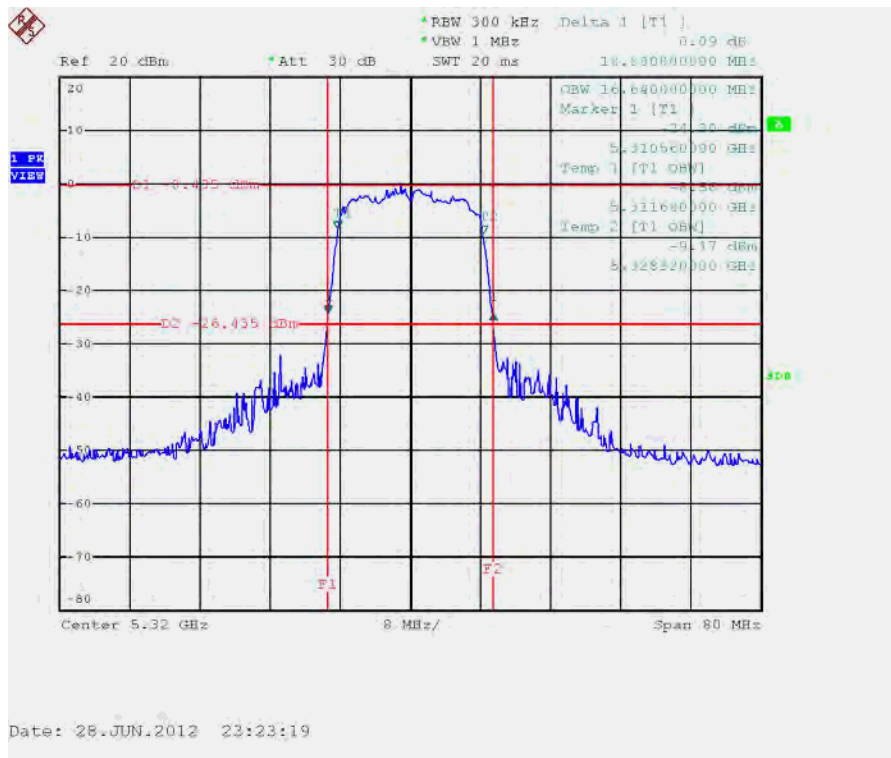

26 dB Bandwidth Plot on Configuration IEEE 802.11a / Ant. B / 5500 MHz

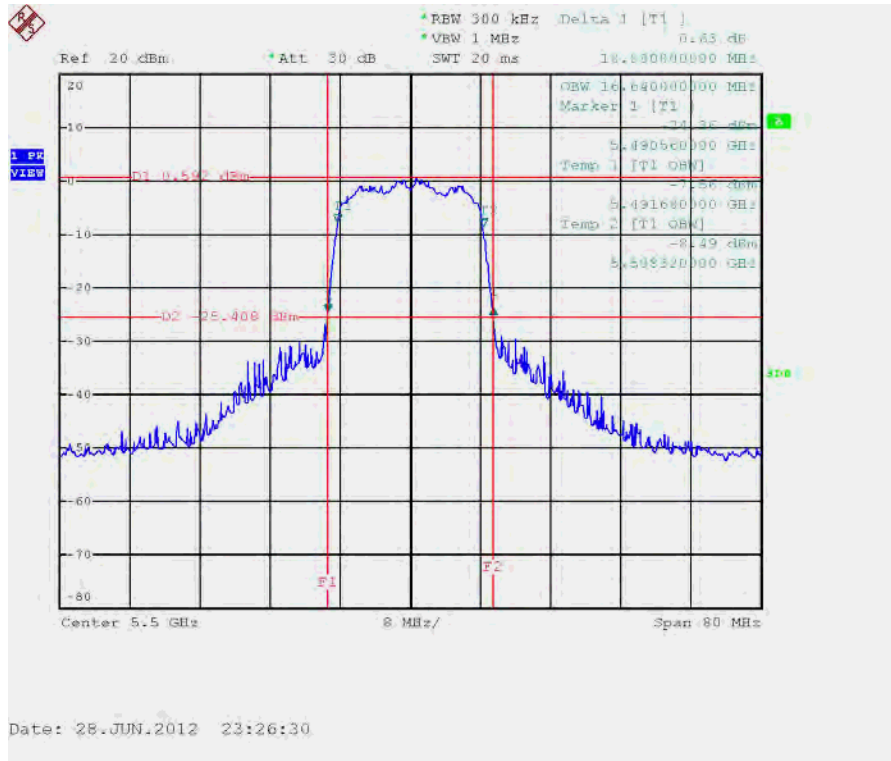

26 dB Bandwidth Plot on Configuration IEEE 802.11a / Ant. B / 5580 MHz

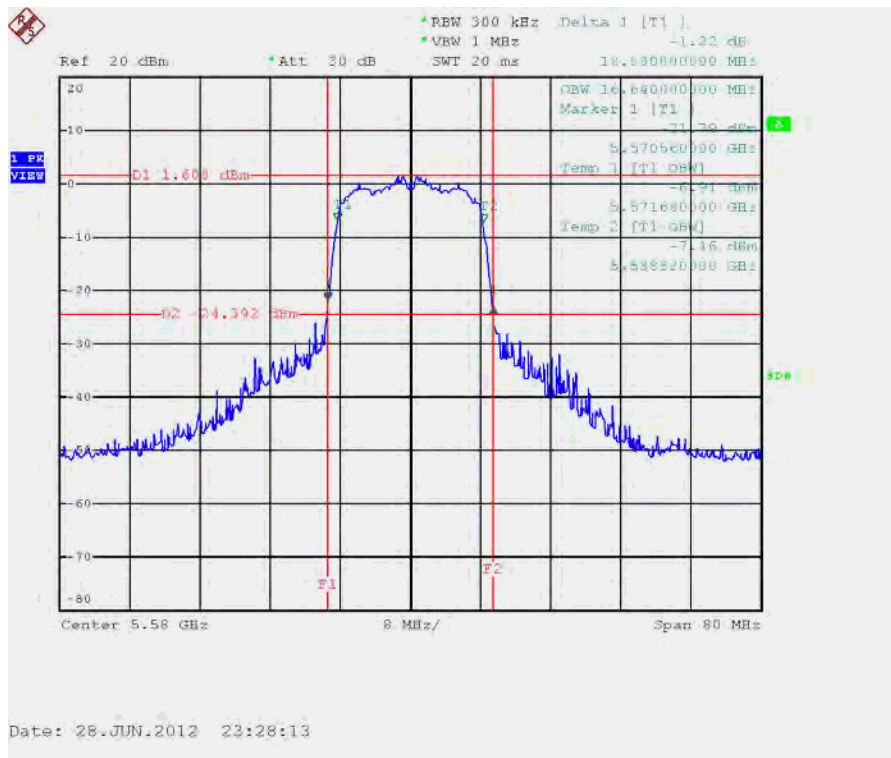

26 dB Bandwidth Plot on Configuration IEEE 802.11a / Ant. B / 5700 MHz

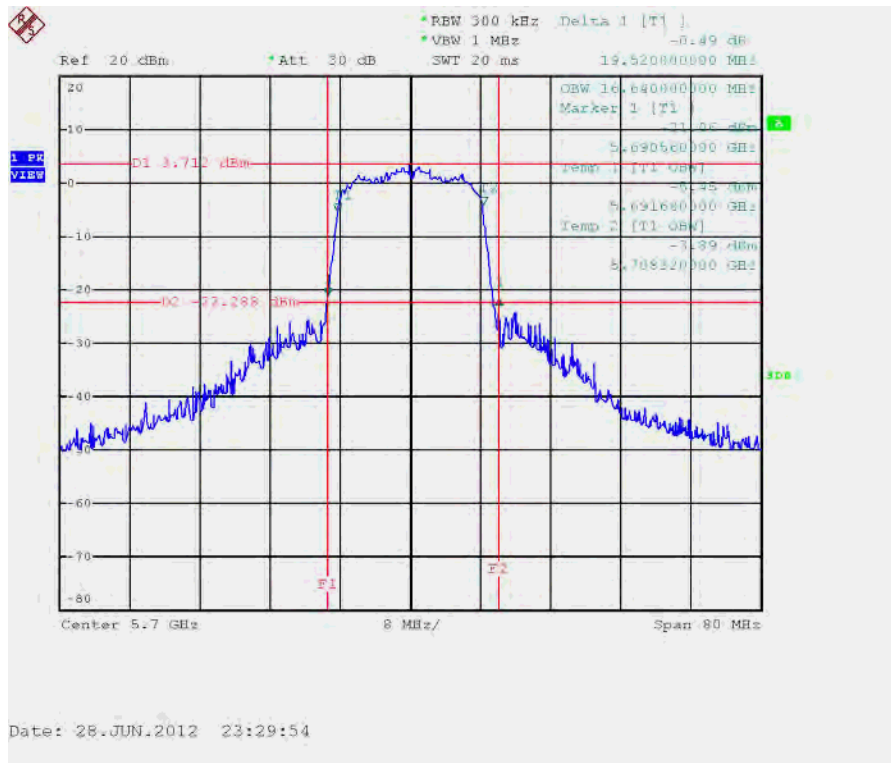



### 4.3. Maximum Conducted Output Power Measurement

#### 4.3.1 Limit

For the band 5.15~5.25 GHz, the maximum conducted output power over the frequency band of operation shall not exceed the lesser of 50 mW (17dBm) or  $4 \text{ dBm} + 10\log B$ , where B is the 26 dB emissions bandwidth in MHz. If transmitting antennas of directional gain greater than 6 dBi are used, both the maximum conducted output power and the peak power spectral density shall be reduced by the amount in dB that the directional gain of the antenna exceeds 6 dBi.

For the 5.25-5.35 GHz and 5.470-5.725 GHz bands, the maximum conducted output power over the frequency bands of operation shall not exceed the lesser of 250 mW (24dBm) or  $11 \text{ dBm} + 10\log B$ , where B is the 26-dB emission bandwidth in MHz. If transmitting antennas of directional gain greater than 6 dBi are used, both the maximum conducted output power and the peak power spectral density shall be reduced by the amount in dB that the directional gain of the antenna exceeds 6 dBi.

For the band 5.725~5.825 GHz, the maximum conducted output power over the frequency band of operation shall not exceed the lesser of 1 W or  $17 \text{ dBm} + 10 \log B$ , where B is the 26-dB emission bandwidth in MHz. In addition, the peak power spectral density shall not exceed 17 dBm in any 1MHz band. If transmitting antennas of directional gain greater than 6 dBi are used, both the maximum conducted output power and the peak power spectral density shall be reduced by the amount in dB that the directional gain of the antenna exceeds 6 dBi. However, fixed point-to-point U-NII devices operating in this band may employ transmitting antennas with directional gain up to 23 dBi without any corresponding reduction in the transmitter peak output power or peak power spectral density. For fixed, point-to-point U-NII transmitters that employ a directional antenna gain greater than 23 dBi, a 1 dB reduction in peak transmitter power and peak power spectral density for each 1 dB of antenna gain in excess of 23 dBi would be required.

#### 4.3.2. Measuring Instruments and Setting

The following table is the setting of the peak power meter.

Power Meter Parameter	Setting
Bandwidth	50MHz bandwidth is greater than the EUT emission bandwidth
Detector	AVERAGE

#### 4.3.3. Test Procedures

1. The transmitter output (antenna port) was connected to the power meter.
2. Test was performed in accordance with KDB 789033 Guidelines for Compliance Testing of Unlicensed National Information Infrastructure (U-NII) Devices - Part 15, Subpart E, section (C) Maximum conducted output power =>(4) Method PM (Measurement using an RF average power meter) Multiple antenna systems was performed in accordance with KDB 662911 Emissions Testing of Transmitters with Multiple Outputs in the Same Band.
3. When measuring maximum conducted output power with multiple antenna systems, add every

result of the values by mathematic formula.

#### 4.3.4. Test Setup Layout

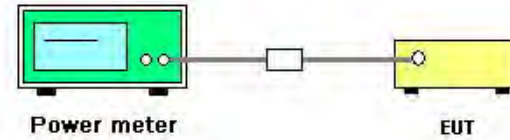

#### 4.3.5. Test Deviation

There is no deviation with the original standard.

#### 4.3.6. EUT Operation during Test

The EUT was programmed to be in continuously transmitting mode.

#### 4.3.7. Test Result of Maximum Conducted Output Power

Temperature	24°C	Humidity	63%
Test Engineer	Satoshi Yang	Configurations	IEEE 802.11n
Test Date	Jun. 28, 2012		

#### Configuration IEEE 802.11n MCS0 20MHz / Ant. B

Channel	Frequency	Conducted Power (dBm)	Max. Limit (dBm)	Result
36	5180 MHz	12.01	16.90	Complies
40	5200 MHz	11.98	16.87	Complies
48	5240 MHz	12.09	16.83	Complies
52	5260 MHz	12.11	23.83	Complies
60	5300 MHz	12.06	23.87	Complies
64	5320 MHz	12.17	23.87	Complies
100	5500 MHz	12.17	23.87	Complies
116	5580 MHz	12.17	23.87	Complies
140	5700 MHz	11.93	23.83	Complies

<b>Temperature</b>	24°C	<b>Humidity</b>	63%
<b>Test Engineer</b>	Satoshi Yang	<b>Configurations</b>	IEEE 802.11a
<b>Test Date</b>	Jun. 28, 2012		

**Configuration IEEE 802.11a / Ant. B**

Channel	Frequency	Conducted Power (dBm)	Max. Limit (dBm)	Result
36	5180 MHz	13.13	16.80	<b>Complies</b>
40	5200 MHz	13.03	16.72	<b>Complies</b>
48	5240 MHz	13.08	16.72	<b>Complies</b>
52	5260 MHz	13.08	23.83	<b>Complies</b>
60	5300 MHz	13.18	23.76	<b>Complies</b>
64	5320 MHz	13.21	23.76	<b>Complies</b>
100	5500 MHz	13.24	23.76	<b>Complies</b>
116	5580 MHz	13.02	23.76	<b>Complies</b>
140	5700 MHz	13.38	23.90	<b>Complies</b>

## 4.4. Power Spectral Density Measurement

### 4.4.1. Limit

The power spectral density is defined as the highest level of power in dBm per MHz generated by the transmitter within the power envelope. The following table is power spectral density limits and decrease power density limit rule refer to section 4.3.1.

Frequency Range	Power Spectral Density limit (dBm/MHz)
5.15~5.25 GHz	4
5.25-5.35 GHz	11
5470-5725	11

### 4.4.2. Measuring Instruments and Setting

Please refer to section 5 of equipments list in this report. The following table is the setting of the spectrum analyzer.

Spectrum Parameter	Setting
Attenuation	Auto
Span Frequency	Encompass the entire emissions bandwidth (EBW) of the signal
RB	1000 kHz
VB	3000 kHz
Detector	RMS
Trace	AVERAGE
Sweep Time	Auto
Trace Average	100 times

### 4.4.3. Test Procedures

1. The transmitter output (antenna port) was connected RF switch to the spectrum analyzer.
2. Test was performed in accordance with KDB 789033 Guidelines for Compliance Testing of Unlicensed National Information Infrastructure (U-NII) Devices - Part 15, Subpart E, section (C) Maximum conducted output power => (d) Method SA-2 (trace averaging across on and off times of the EUT transmissions, followed by duty cycle correction).
3. Multiple antenna systems was performed in accordance with KDB 662911 in-Band Power Spectral Density (PSD) Measurements (1) Measure and sum the spectra across the outputs.
4. When measuring first spectral bin of output 1 is summed with that in the first spectral bin of output 2 and that from the first spectral bin of output 3 and so on up to the Nth output to obtain the value for the first frequency bin of the summed spectrum. the summed spectrum value for each of the other frequency bins is computed in the same way.

### 4.4.4. Test Setup Layout

This test setup layout is the same as that shown in section 4.6.4.

#### 4.4.5. Test Deviation

There is no deviation with the original standard.

#### 4.4.6. EUT Operation during Test

The EUT was programmed to be in continuously transmitting mode.

#### 4.4.7. Test Result of Power Spectral Density

Temperature	24°C	Humidity	63%
Test Engineer	Satoshi Yang	Configurations	IEEE 802.11n
Test Date	Jun. 29, 2012		

#### Configuration IEEE 802.11n MCS0 20MHz

Channel	Frequency	Power Density (dBm/3kHz)	Max. Limit (dBm/3kHz)	Result
		Ant. B		
36	5180 MHz	-2.42	4.00	Complies
40	5200 MHz	-2.47	4.00	Complies
48	5240 MHz	-2.89	4.00	Complies
52	5260 MHz	-3.24	11.00	Complies
60	5300 MHz	-3.88	11.00	Complies
64	5320 MHz	-4.05	11.00	Complies
100	5500 MHz	-3.99	11.00	Complies
116	5580 MHz	-3.13	11.00	Complies
140	5700 MHz	-1.88	11.00	Complies

<b>Temperature</b>	24°C	<b>Humidity</b>	63%
<b>Test Engineer</b>	Satoshi Yang	<b>Configurations</b>	IEEE 802.11a
<b>Test Date</b>	Jun. 29, 2012		

**Configuration IEEE 802.11a**

Channel	Frequency	Power Density (dBm/3kHz)	Max. Limit (dBm/3kHz)	Result
		Ant. B		
36	5180 MHz	-1.05	4.00	<b>Complies</b>
40	5200 MHz	-1.02	4.00	<b>Complies</b>
48	5240 MHz	-1.47	4.00	<b>Complies</b>
52	5260 MHz	-1.79	11.00	<b>Complies</b>
60	5300 MHz	-2.44	11.00	<b>Complies</b>
64	5320 MHz	-2.60	11.00	<b>Complies</b>
100	5500 MHz	-2.48	11.00	<b>Complies</b>
116	5580 MHz	-1.74	11.00	<b>Complies</b>
140	5700 MHz	0.01	11.00	<b>Complies</b>

Note: All the test values were listed in the report.

For plots, only the channel with maximum results was shown.



## Power Density Plot on Configuration IEEE 802.11n MCS0 20MHz / Ant. B / 5180 MHz

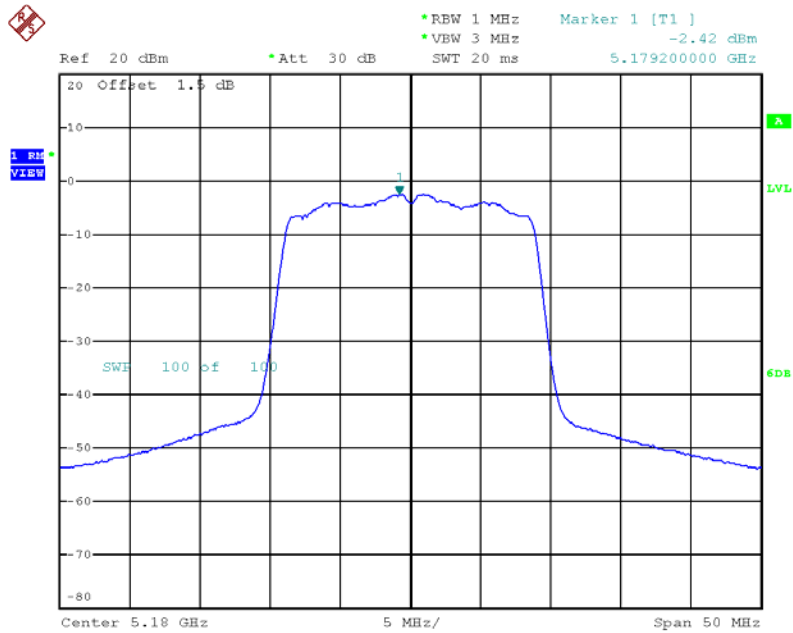

Date: 29.JUN.2012 00:23:11

## Power Density Plot on Configuration IEEE 802.11n MCS0 20MHz / Ant. B / 5260 MHz

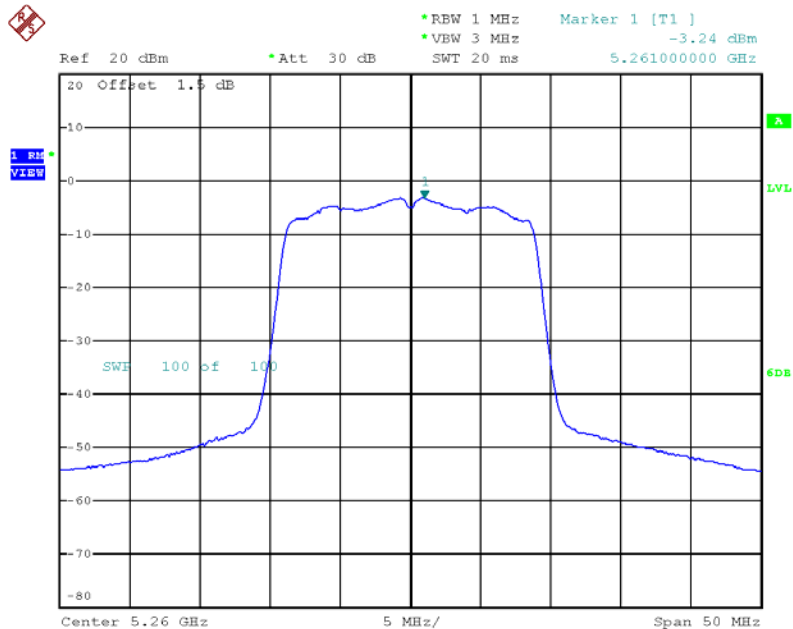

Date: 29.JUN.2012 00:20:49

### Power Density Plot on Configuration IEEE 802.11n MCS0 20MHz / Ant. B / 5700 MHz

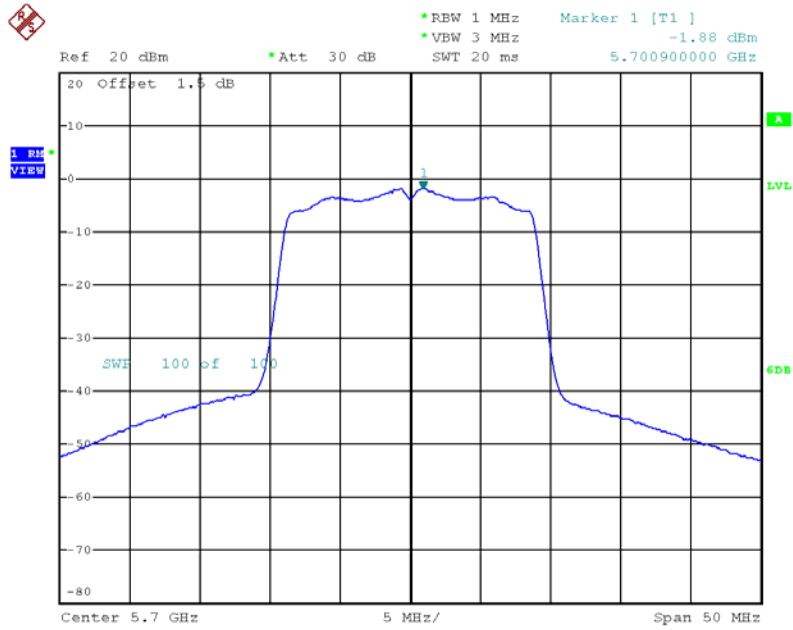

Date: 29.JUN.2012 00:15:37

**Power Density Plot on Configuration IEEE 802.11a / Ant. B / 5200 MHz**

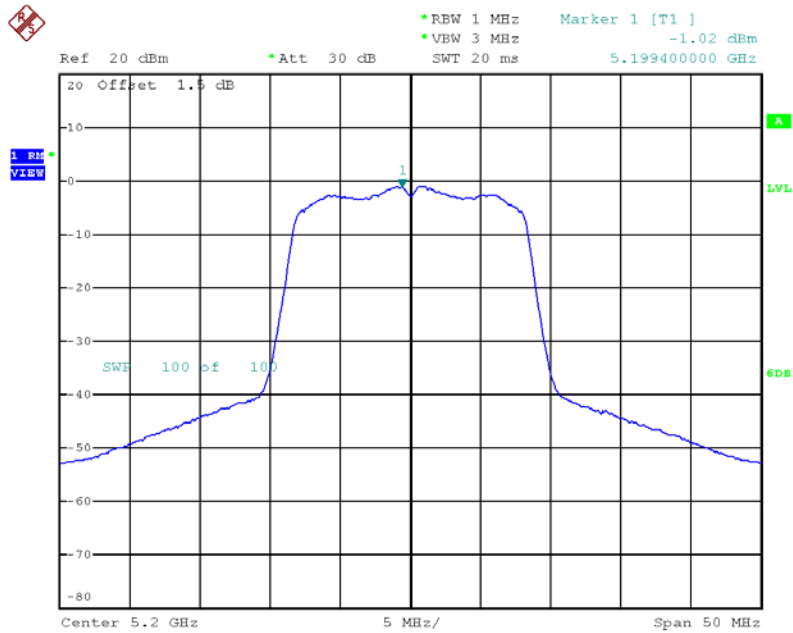

Date: 29.JUN.2012 00:26:28

**Power Density Plot on Configuration IEEE 802.11a / Ant. B / 5260 MHz**

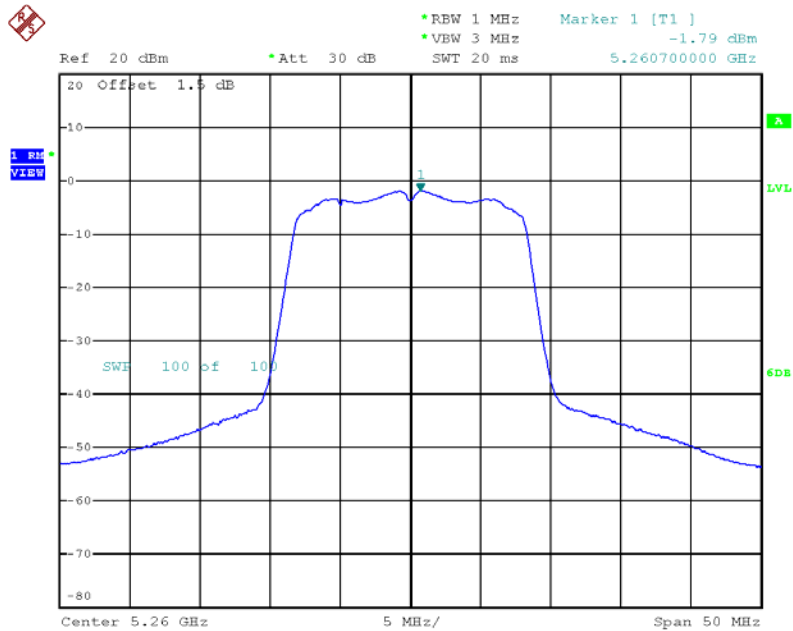

Date: 29.JUN.2012 00:28:05

### Power Density Plot on Configuration IEEE 802.11a / Ant. B / 5700 MHz

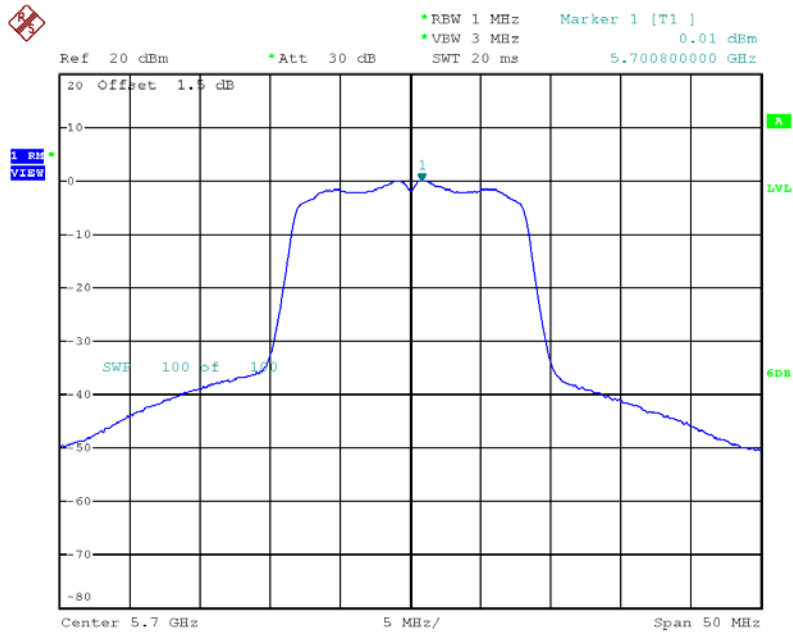

Date: 29.JUN.2012 00:32:53

## 4.5. Peak Excursion Measurement

### 4.5.1. Limit

The ratio of the peak excursion of the modulation envelope (measured using a peak hold function) to the maximum conducted output power (measured as specified above) shall not exceed 13 dB across any 1 MHz bandwidth or the emissions bandwidth whichever is less.

### 4.5.2. Measuring Instruments and Setting

Please refer to section 5 of equipments list in this report. The following table is the setting of the spectrum analyzer.

Spectrum Parameter	Setting
Attenuation	Auto
Span Frequency	Encompass the entire emissions bandwidth (EBW) of the signal
RB	1MHz (Peak Trace) / 1MHz (Average Trace)
VB	3MHz (Peak Trace) / 3MHz (Average Trace)
Detector	Peak (Peak Trace) / RMS
Trace	Peak : Trace :Max hold/Average: Trace Average Sweep Count 100
Sweep Time	AUTO

### 4.5.3. Test Procedures

1. The test procedure is the same as section 4.6.3.
2. Trace A, Set RBW = 1MHz, VBW = 3MHz, Span >26dB bandwidth, Max. hold.
3. Delta Mark trace A Maximum frequency and trace B same frequency.
4. Repeat the above procedure until measurements for all frequencies were complete.

### 4.5.4. Test Setup Layout

This test setup layout is the same as that shown in section 4.6.4.

### 4.5.5. Test Deviation

There is no deviation with the original standard.

### 4.5.6. EUT Operation during Test

The EUT was programmed to be in continuously transmitting mode.

#### 4.5.7. Test Result of Peak Excursion

<b>Temperature</b>	24°C	<b>Humidity</b>	63%
<b>Test Engineer</b>	Satoshi Yang	<b>Configurations</b>	IEEE 802.11n

#### Configuration IEEE 802.11n MCS0 20MHz / Ant. B

Channel	Frequency	Peak Excursion (dB)	Max. Limit (dB)	Result
36	5180 MHz	9.36	13	Complies
40	5200 MHz	10.24	13	Complies
48	5240 MHz	9.30	13	Complies
52	5260 MHz	9.53	13	Complies
60	5300 MHz	9.26	13	Complies
64	5320 MHz	9.95	13	Complies
100	5500 MHz	9.06	13	Complies
116	5580 MHz	9.21	13	Complies
140	5700 MHz	8.72	13	Complies

<b>Temperature</b>	24°C	<b>Humidity</b>	63%
<b>Test Engineer</b>	Satoshi Yang	<b>Configurations</b>	IEEE 802.11a

**Configuration IEEE 802.11a / Ant. B**

Channel	Frequency	Peak Excursion (dB)	Max. Limit (dB)	Result
36	5180 MHz	9.22	13	Complies
40	5200 MHz	9.10	13	Complies
48	5240 MHz	9.30	13	Complies
52	5260 MHz	9.06	13	Complies
60	5300 MHz	9.34	13	Complies
64	5320 MHz	9.28	13	Complies
100	5500 MHz	9.00	13	Complies
116	5580 MHz	9.06	13	Complies
140	5700 MHz	9.30	13	Complies

Note: All the test values were listed in the report.

For plots, only the channel with maximum results was shown.

Peak Excursion Plot on Configuration IEEE 802.11n MCS0 20MHz / Ant. B / 5200 MHz

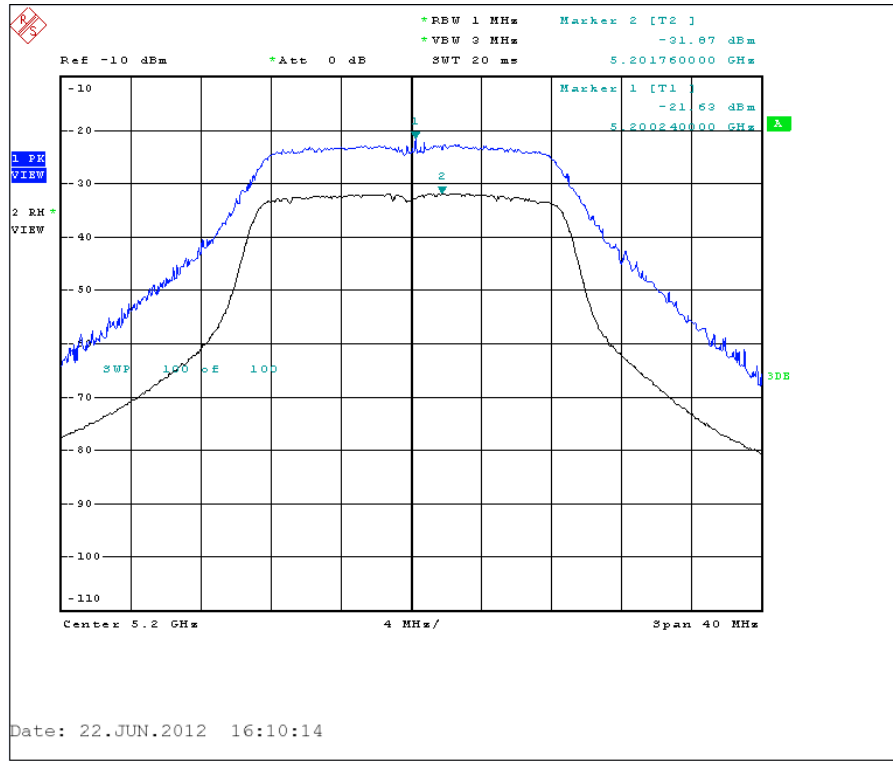

Peak Excursion Plot on Configuration IEEE 802.11n MCS0 20MHz / Ant. B / 5320 MHz

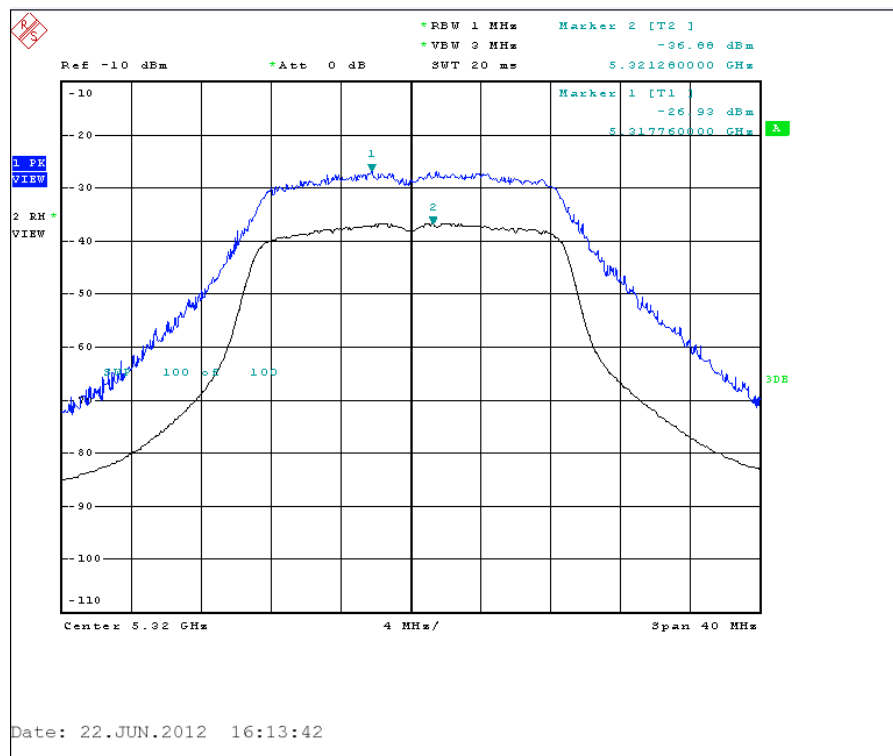



Peak Excursion Plot on Configuration IEEE 802.11n MCS0 20MHz / Ant. B / 5580 MHz

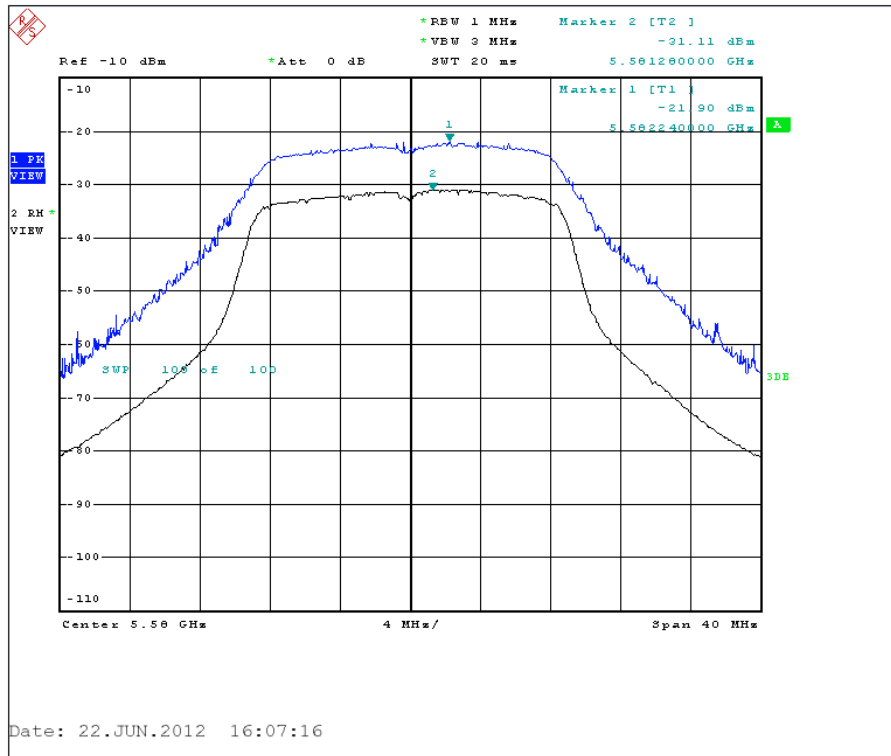

Peak Excursion Plot on Configuration IEEE 802.11a / Ant. B / 5240 MHz

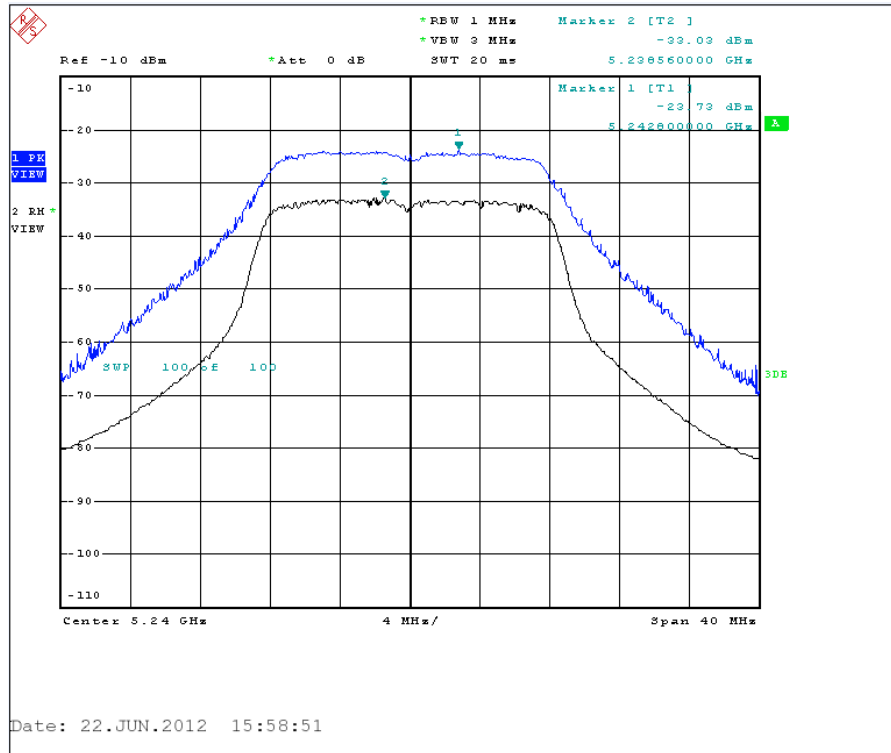

Peak Excursion Plot on Configuration IEEE 802.11a / Ant. B / 5300 MHz

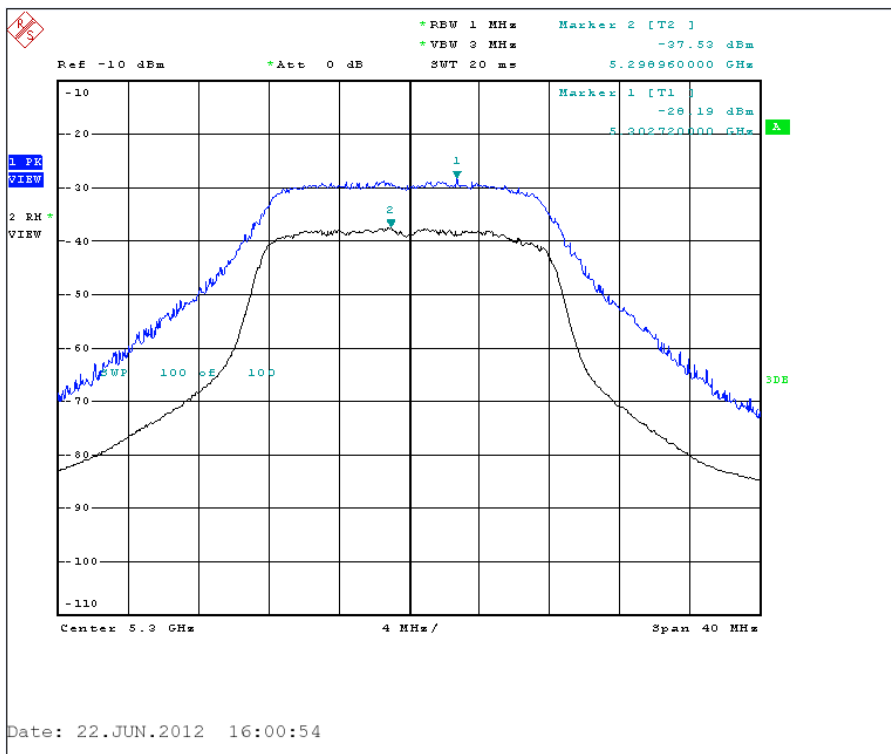

Peak Excursion Plot on Configuration IEEE 802.11a / Ant. B / 5700 MHz

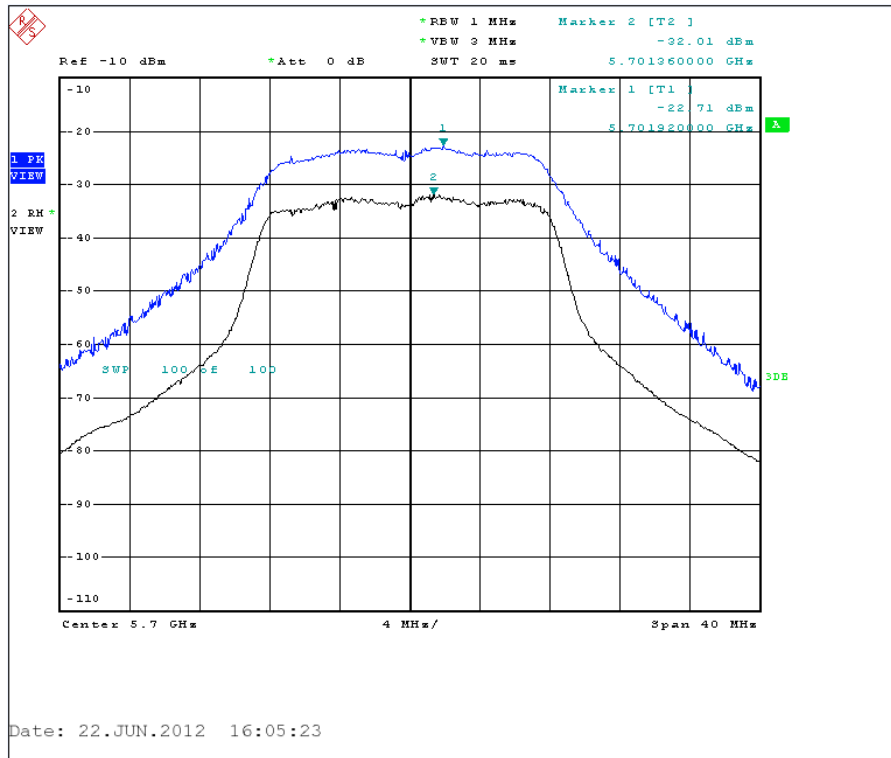

## 4.6. Radiated Emissions Measurement

### 4.6.1. Limit

For transmitters operating in the 5.15-5.35 GHz band: all emissions outside of the 5.15-5.35 GHz band shall not exceed an EIRP of -27 dBm/MHz (68.3dBuV/m at 3m). For transmitters operating in the 5.470-5.725 GHz band: all emissions outside of the 5.470-5.725 GHz band shall not exceed an EIRP of -27 dBm/MHz (68.3dBuV/m at 3m). For transmitters operating in the 5.725-5.825 GHz band: all emissions within the frequency range from the band edge to 10 MHz above or below the band edge shall not exceed an EIRP of -17 dBm/MHz (78.3dBuV/m at 3m); for frequencies 10 MHz or greater above or below the band edge, emissions shall not exceed an EIRP of -27 dBm/MHz (68.3dBuV/m at 3m). In addition, in case the emission falls within the restricted band specified on 15.205(a), then the 15.209(a) limit in the table below has to be followed.

Frequencies (MHz)	Field Strength (microrvolts/meter)	Measurement Distance (meters)
0.009~0.490	2400/F(KHz)	300
0.490~1.705	24000/F(KHz)	30
1.705~30.0	30	30
30~88	100	3
88~216	150	3
216~960	200	3
Above 960	500	3

### 4.6.2. Measuring Instruments and Setting

Please refer to section 5 of equipments list in this report. The following table is the setting of spectrum analyzer and receiver.

Spectrum Parameter	Setting
Attenuation	Auto
Start Frequency	1000 MHz
Stop Frequency	40 GHz
RB / VB (Emission in restricted band)	1 MHz / 3MHz for Peak, 1 MHz / 10Hz for Average
RB / VB (Emission in non-restricted band)	1 MHz / 3MHz for peak

Receiver Parameter	Setting
Attenuation	Auto
Start ~ Stop Frequency	9kHz~150kHz / RB 200Hz for QP
Start ~ Stop Frequency	150kHz~30MHz / RB 9kHz for QP
Start ~ Stop Frequency	30MHz~1000MHz / RB 120kHz for QP

#### 4.6.3. Test Procedures

1. Configure the EUT according to ANSI C63.10. The EUT was placed on the top of the turntable 0.8 meter above ground. The phase center of the receiving antenna mounted on the top of a height-variable antenna tower was placed 3 meters far away from the turntable.
2. Power on the EUT and all the supporting units. The turntable was rotated by 360 degrees to determine the position of the highest radiation.
3. The height of the broadband receiving antenna was varied between one meter and four meters above ground to find the maximum emissions field strength of both horizontal and vertical polarization.
4. For each suspected emissions, the antenna tower was scan (from 1 M to 4 M) and then the turntable was rotated (from 0 degree to 360 degrees) to find the maximum reading.
5. Set the test-receiver system to Peak or CISPR quasi-peak Detect Function with specified bandwidth under Maximum Hold Mode.
6. For emissions above 1GHz, use 1MHz VBW and RBW for peak reading. Then 1MHz RBW and 10Hz VBW for average reading in spectrum analyzer.
7. When the radiated emissions limits are expressed in terms of the average value of the emissions, and pulsed operation is employed, the measurement field strength shall be determined by averaging over one complete pulse train, including blanking intervals, as long as the pulse train does not exceed 0.1 seconds. As an alternative (provided the transmitter operates for longer than 0.1 seconds) or in cases where the pulse train exceeds 0.1 seconds, the measured field strength shall be determined from the average absolute voltage during a 0.1 second interval during which the field strength is at its maximum value.
8. If the emissions level of the EUT in peak mode was 3 dB lower than the average limit specified, then testing will be stopped and peak values of EUT will be reported, otherwise, the emissions which do not have 3 dB margin will be repeated one by one using the quasi-peak method for below 1GHz.
9. For testing above 1GHz, the emissions level of the EUT in peak mode was lower than average limit (that means the emissions level in peak mode also complies with the limit in average mode), then testing will be stopped and peak values of EUT will be reported, otherwise, the emissions will be measured in average mode again and reported.
10. In case the emission is lower than 30MHz, loop antenna has to be used for measurement and the recorded data should be QP measured by receiver. High – Low scan is not required in this case.

#### 4.6.4. Test Setup Layout

For radiated emissions below 1GHz

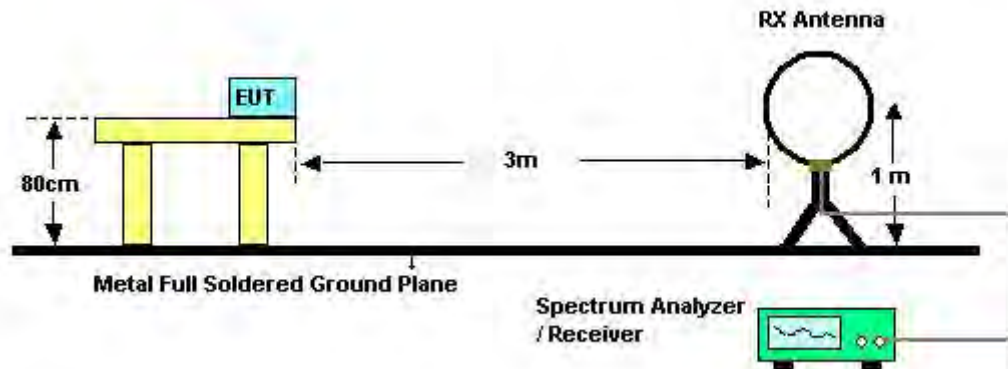

For radiated emissions above 1GHz

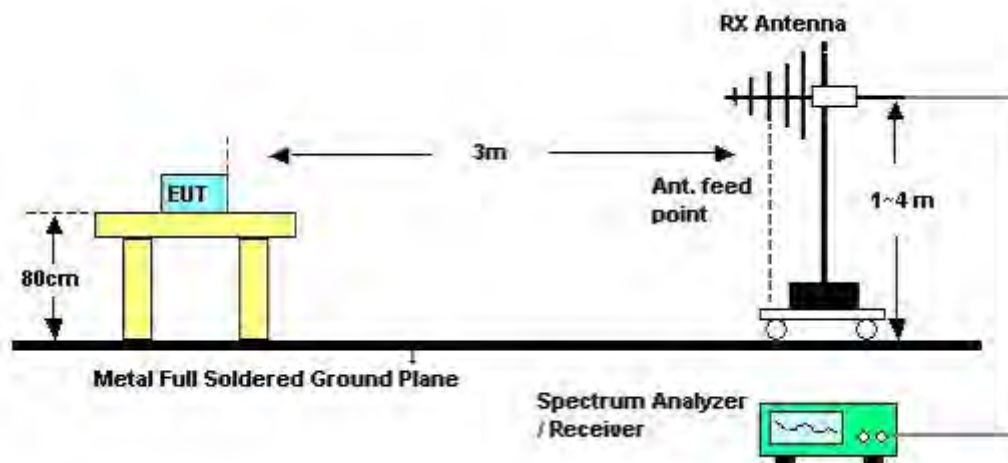

#### 4.6.5. Test Deviation

There is no deviation with the original standard.

#### 4.6.6. EUT Operation during Test

The EUT was programmed to be in continuously transmitting mode.

#### 4.6.7. Results of Radiated Emissions (9kHz~30MHz)

<b>Temperature</b>	21°C	<b>Humidity</b>	56.4%
<b>Test Engineer</b>	Benson Peng	<b>Configurations</b>	Normal Link
<b>Test Date</b>	Jul. 06, 2012		

<b>Freq. (MHz)</b>	<b>Level (dBuV)</b>	<b>Over Limit (dB)</b>	<b>Limit Line (dBuV)</b>	<b>Remark</b>
-	-	-	-	See Note

Note:

The amplitude of spurious emissions that are attenuated by more than 20dB below the permissible value has no need to be reported.

Distance extrapolation factor =  $40 \log(\text{specific distance} / \text{test distance})$  (dB);

Limit line = specific limits (dBuV) + distance extrapolation factor.

4.6.8. Results of Radiated Emissions (30MHz~1GHz)

Temperature	21°C	Humidity	56.4%
Test Engineer	Benson Peng	Configurations	Normal Link

Horizontal

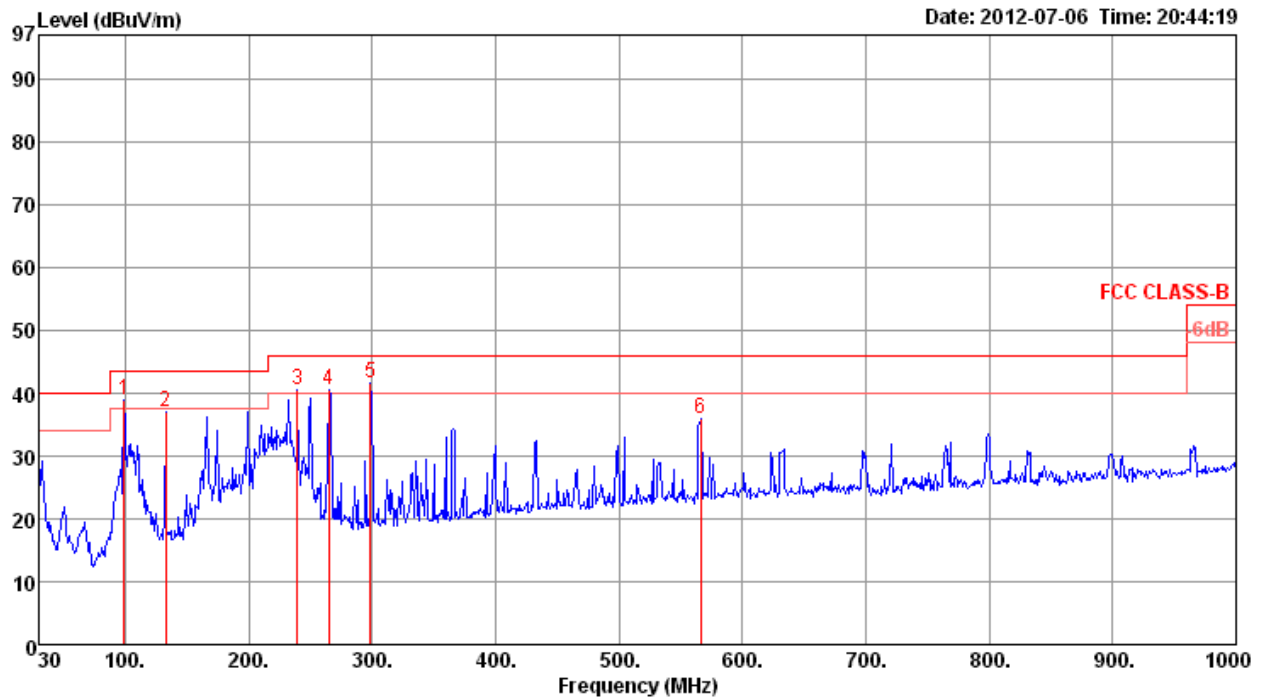

	Freq	Level	Limit	Over	Read	Cable	Antenna	Preamp	Remark	A/Pos	T/Pos	PoI/Phase
	MHz	dBuV/m	dBuV/m	dB	dBuV	dB	dB/m	dB		cm	deg	
1	98.87	38.89	43.50	-4.61	54.53	1.18	10.79	27.61	Peak	100	0	HORIZONTAL
2	132.82	37.01	43.50	-6.49	50.83	1.33	12.28	27.43	Peak	100	0	HORIZONTAL
3	239.52	40.60	46.00	-5.40	53.78	1.86	11.98	27.02	Peak	100	0	HORIZONTAL
4	264.74	40.59	46.00	-5.41	52.66	1.96	12.94	26.97	Peak	100	0	HORIZONTAL
5	298.69	41.54	46.00	-4.46	52.99	2.10	13.35	26.90	Peak	100	0	HORIZONTAL
6	566.41	35.94	46.00	-10.06	42.83	2.83	18.38	28.10	Peak	100	0	HORIZONTAL



**Vertical**

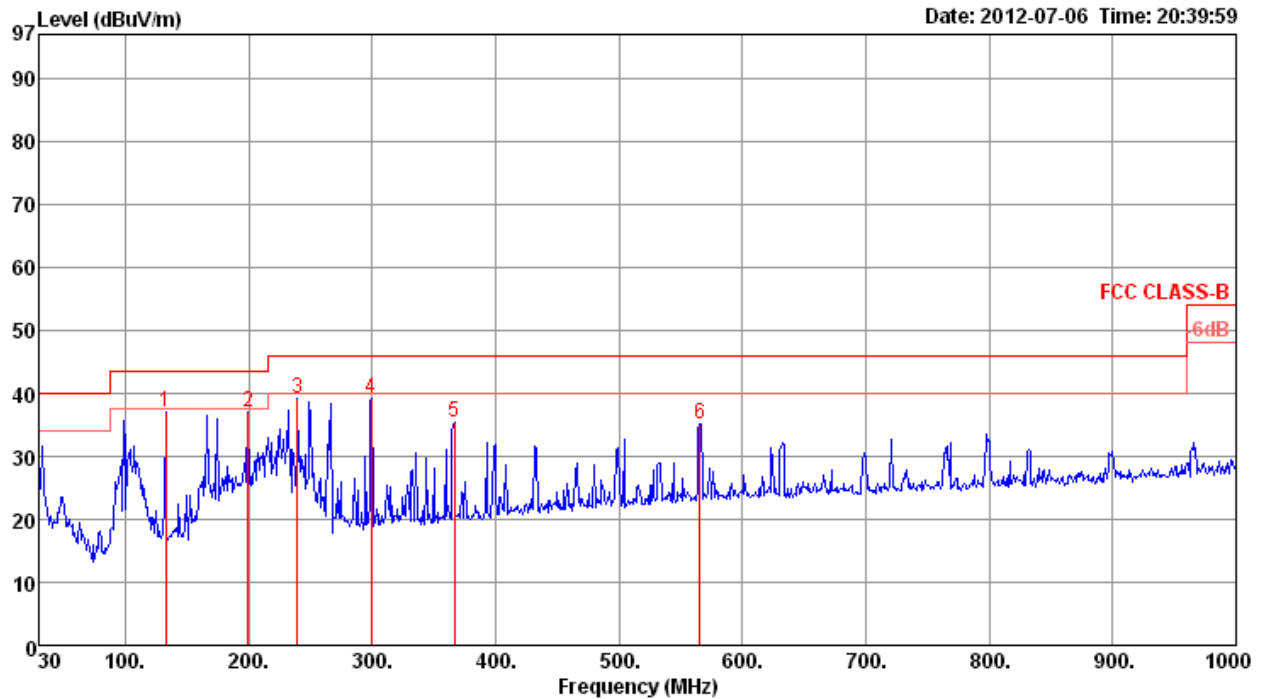

	Freq	Level	Limit Line	Over Limit	Read Level	CableAntenna Loss	Preamp Factor	Preamp Factor	Remark	A/Pos	T/Pos	Pol/Phase
	MHz	dBuV/m	dBuV/m	dB	dBuV	dB	dB/m	dB		cm	deg	
1	132.82	37.02	43.50	-6.48	50.84	1.33	12.28	27.43	Peak	400	0	VERTICAL
2	199.75	37.07	43.50	-6.43	53.42	1.70	9.05	27.10	Peak	400	0	VERTICAL
3	239.52	39.09	46.00	-6.91	52.27	1.86	11.98	27.02	Peak	400	0	VERTICAL
4	299.66	39.05	46.00	-6.95	50.49	2.10	13.36	26.90	Peak	400	0	VERTICAL
5	366.59	35.27	46.00	-10.73	45.24	2.23	15.17	27.37	Peak	400	0	VERTICAL
6	565.44	35.16	46.00	-10.84	42.06	2.83	18.37	28.10	Peak	400	0	VERTICAL

**Note:**

The amplitude of spurious emissions that are attenuated by more than 20dB below the permissible value has no need to be reported.

Emission level (dBuV/m) = 20 log Emission level (uV/m).

Corrected Reading: Antenna Factor + Cable Loss + Read Level - Preamp Factor = Level.

#### 4.6.9. Results for Radiated Emissions (1GHz~40GHz)

<b>Temperature</b>	25.6°C	<b>Humidity</b>	56%
<b>Test Engineer</b>	Serway Li	<b>Configurations</b>	IEEE 802.11n MCS0 20MHz Ch 36 / Ant. B
<b>Test Date</b>	Jun. 15, 2012		

##### *Horizontal*

	Freq	Level	Limit Line	Over Limit	Read Level	CableAntenna Loss	Antenna Factor	Preamp Factor	Remark	A/Pos	T/Pos	Pol/Phase
	MHz	dBuV/m	dBuV/m	dB	dBuV	dB	dB/m	dB		cm	deg	
1	15539.81	51.33	74.00	-22.67	42.86	6.13	37.65	35.31	Peak	100	148	HORIZONTAL
2	15540.44	39.02	54.00	-14.98	30.55	6.13	37.65	35.31	Average	100	148	HORIZONTAL

##### *Vertical*

	Freq	Level	Limit Line	Over Limit	Read Level	CableAntenna Loss	Antenna Factor	Preamp Factor	Remark	A/Pos	T/Pos	Pol/Phase
	MHz	dBuV/m	dBuV/m	dB	dBuV	dB	dB/m	dB		cm	deg	
1	15540.04	51.69	74.00	-22.31	43.18	6.13	37.69	35.31	Peak	100	213	VERTICAL
2	15541.35	39.27	54.00	-14.73	30.76	6.13	37.69	35.31	Average	100	213	VERTICAL



<b>Temperature</b>	25°C	<b>Humidity</b>	56%
<b>Test Engineer</b>	Serway Li	<b>Configurations</b>	IEEE 802.11n MCS0 20MHz Ch 40 / Ant. B
<b>Test Date</b>	Jun. 15, 2012		

**Horizontal**

	Freq	Level	Limit Line	Over Limit	Read Level	Cable Loss	Antenna Factor	Preamp Factor	Remark	A/Pos	T/Pos	Pol/Phase
	MHz	dBuV/m	dBuV/m	dB	dBuV	dB	dB/m	dB		cm	deg	
1	15600.35	51.75	74.00	-22.25	43.36	6.13	37.60	35.34	Peak	100	186	HORIZONTAL
2	15600.35	38.28	54.00	-15.72	29.89	6.13	37.60	35.34	Average	100	186	HORIZONTAL

**Vertical**

	Freq	Level	Limit Line	Over Limit	Read Level	Cable Loss	Antenna Factor	Preamp Factor	Remark	A/Pos	T/Pos	Pol/Phase
	MHz	dBuV/m	dBuV/m	dB	dBuV	dB	dB/m	dB		cm	deg	
1	15600.27	39.67	54.00	-14.33	31.28	6.13	37.60	35.34	Average	100	272	VERTICAL
2	15600.35	52.06	74.00	-21.94	43.67	6.13	37.60	35.34	Peak	100	272	VERTICAL

<b>Temperature</b>	25°C	<b>Humidity</b>	56%
<b>Test Engineer</b>	Serway Li	<b>Configurations</b>	IEEE 802.11n MCS0 20MHz Ch 48 / Ant. B
<b>Test Date</b>	Jun. 15, 2012		

### Horizontal

	Freq	Level	Limit Line	Over Limit	Read Level	CableAntenna Loss	Antenna Factor	Preamp Factor	Remark	A/Pos	T/Pos	Pol/Phase
	MHz	dBuV/m	dBuV/m	dB	dBuV	dB	dB/m	dB		cm	deg	
1	15719.56	51.40	74.00	-22.60	43.17	6.14	37.48	35.39	Peak	100	123	VERTICAL
2	15719.92	39.41	54.00	-14.59	31.18	6.14	37.48	35.39	Average	100	123	VERTICAL

### Vertical

	Freq	Level	Limit Line	Over Limit	Read Level	CableAntenna Loss	Antenna Factor	Preamp Factor	Remark	A/Pos	T/Pos	Pol/Phase
	MHz	dBuV/m	dBuV/m	dB	dBuV	dB	dB/m	dB		cm	deg	
1	15719.77	51.00	74.00	-23.00	42.77	6.14	37.48	35.39	Peak	100	292	HORIZONTAL
2	15720.38	38.16	54.00	-15.84	29.93	6.14	37.48	35.39	Average	100	292	HORIZONTAL



<b>Temperature</b>	25°C	<b>Humidity</b>	56%
<b>Test Engineer</b>	Serway Li	<b>Configurations</b>	IEEE 802.11n MCS0 20MHz Ch 52 / Ant. B
<b>Test Date</b>	Jun. 15, 2012		

**Horizontal**

	Freq	Level	Limit Line	Over Limit	Read Level	CableAntenna Loss	Antenna Factor	Preamp Factor	Remark	A/Pos	T/Pos	Pol/Phase
	MHz	dBuV/m	dBuV/m	dB	dBuV	dB	dB/m	dB		cm	deg	
1	15779.60	38.16	54.00	-15.84	30.03	6.14	37.41	35.42	Average	100	301	HORIZONTAL
2	15779.88	50.13	74.00	-23.87	42.00	6.14	37.41	35.42	Peak	100	301	HORIZONTAL

**Vertical**

	Freq	Level	Limit Line	Over Limit	Read Level	CableAntenna Loss	Antenna Factor	Preamp Factor	Remark	A/Pos	T/Pos	Pol/Phase
	MHz	dBuV/m	dBuV/m	dB	dBuV	dB	dB/m	dB		cm	deg	
1	15779.60	49.72	74.00	-24.28	41.59	6.14	37.41	35.42	Peak	100	133	VERTICAL
2	15779.90	39.54	54.00	-14.46	31.41	6.14	37.41	35.42	Average	100	133	VERTICAL

<b>Temperature</b>	25°C	<b>Humidity</b>	56%
<b>Test Engineer</b>	Serway Li	<b>Configurations</b>	IEEE 802.11n MCS0 20MHz Ch 60 / Ant. B
<b>Test Date</b>	Jun. 15, 2012		

### Horizontal

	Freq	Level	Limit Line	Over Limit	Read Level	CableAntenna Loss	Antenna Factor	Preamp Factor	Remark	A/Pos	T/Pos	Pol/Phase
	MHz	dBuV/m	dBuV/m	dB	dBuV	dB	dB/m	dB		cm	deg	
1	10600.16	45.20	54.00	-8.80	37.23	5.01	38.38	35.42	Average	137	278	HORIZONTAL
2	10600.20	59.46	74.00	-14.54	51.49	5.01	38.38	35.42	Peak	137	278	HORIZONTAL

### Vertical

	Freq	Level	Limit Line	Over Limit	Read Level	CableAntenna Loss	Antenna Factor	Preamp Factor	Remark	A/Pos	T/Pos	Pol/Phase
	MHz	dBuV/m	dBuV/m	dB	dBuV	dB	dB/m	dB		cm	deg	
1	10600.06	43.03	54.00	-10.97	35.06	5.01	38.38	35.42	Average	131	68	VERTICAL
2	10600.06	54.73	74.00	-19.27	46.76	5.01	38.38	35.42	Peak	131	68	VERTICAL



<b>Temperature</b>	25°C	<b>Humidity</b>	56%
<b>Test Engineer</b>	Serway Li	<b>Configurations</b>	IEEE 802.11n MCS0 20MHz Ch 64 / Ant. B
<b>Test Date</b>	Jun. 15, 2012		

**Horizontal**

	Freq	Level	Limit Line	Over Limit	Read Level	Cable Loss	Antenna Factor	Preamp Factor	Remark	A/Pos	T/Pos	Pol/Phase
	MHz	dBuV/m	dBuV/m	dB	dBuV	dB	dB/m	dB		cm	deg	
1	10639.63	60.47	74.00	-13.53	52.48	5.01	38.37	35.39	Peak	126	278	HORIZONTAL
2	10640.11	45.31	54.00	-8.69	37.32	5.01	38.37	35.39	Average	126	278	HORIZONTAL

**Vertical**

	Freq	Level	Limit Line	Over Limit	Read Level	Cable Loss	Antenna Factor	Preamp Factor	Remark	A/Pos	T/Pos	Pol/Phase
	MHz	dBuV/m	dBuV/m	dB	dBuV	dB	dB/m	dB		cm	deg	
1	10639.76	41.42	54.00	-12.58	33.43	5.01	38.37	35.39	Average	122	63	VERTICAL
2	10639.82	56.46	74.00	-17.54	48.47	5.01	38.37	35.39	Peak	122	63	VERTICAL



<b>Temperature</b>	25°C	<b>Humidity</b>	56%
<b>Test Engineer</b>	Serway Li	<b>Configurations</b>	IEEE 802.11n MCS0 20MHz Ch 100 / Ant. B
<b>Test Date</b>	Jun. 15, 2012		

**Horizontal**

	Freq	Level	Limit Line	Over Limit	Read Level	CableAntenna Loss	Antenna Factor	Preamp Factor	Remark	A/Pos	T/Pos	Pol/Phase
	MHz	dBuV/m	dBuV/m	dB	dBuV	dB	dB/m	dB		cm	deg	
1	10999.78	57.60	74.00	-16.40	49.37	5.01	38.32	35.10	Peak	115	69	HORIZONTAL
2	10999.79	42.90	54.00	-11.10	34.67	5.01	38.32	35.10	Average	115	69	HORIZONTAL

**Vertical**

	Freq	Level	Limit Line	Over Limit	Read Level	CableAntenna Loss	Antenna Factor	Preamp Factor	Remark	A/Pos	T/Pos	Pol/Phase
	MHz	dBuV/m	dBuV/m	dB	dBuV	dB	dB/m	dB		cm	deg	
1	10999.65	42.64	54.00	-11.36	34.43	5.01	38.30	35.10	Average	120	285	VERTICAL
2	10999.81	57.46	74.00	-16.54	49.25	5.01	38.30	35.10	Peak	120	285	VERTICAL





<b>Temperature</b>	25°C	<b>Humidity</b>	56%
<b>Test Engineer</b>	Serway Li	<b>Configurations</b>	IEEE 802.11n MCS0 20MHz Ch 116 / Ant. B
<b>Test Date</b>	Jun. 15, 2012		

**Horizontal**

	Freq	Level	Limit	Over	Read	Cable	Antenna	Preamp	Remark	A/Pos	T/Pos	Pol/Phase
	MHz	dBuV/m	dBuV/m	dB	dBuV	Loss	Factor	Factor		cm	deg	
1	11159.64	48.82	54.00	-5.18	40.48	5.04	38.47	35.17	Average	120	69	HORIZONTAL
2	11159.89	64.18	74.00	-9.82	55.84	5.04	38.47	35.17	Peak	120	69	HORIZONTAL

**Vertical**

	Freq	Level	Limit	Over	Read	Cable	Antenna	Preamp	Remark	A/Pos	T/Pos	Pol/Phase
	MHz	dBuV/m	dBuV/m	dB	dBuV	Loss	Factor	Factor		cm	deg	
1	11159.53	51.70	54.00	-2.30	43.36	5.04	38.47	35.17	Average	120	289	VERTICAL
2	11159.63	66.56	74.00	-7.44	58.22	5.04	38.47	35.17	Peak	120	289	VERTICAL

<b>Temperature</b>	25°C	<b>Humidity</b>	56%
<b>Test Engineer</b>	Serway Li	<b>Configurations</b>	IEEE 802.11n MCS0 20MHz Ch 140 / Ant. B
<b>Test Date</b>	Jun. 15, 2012		

### Horizontal

	Freq	Level	Limit Line	Over Limit	Read Level	CableAntenna Loss	Antenna Factor	Preamp Factor	Remark	A/Pos	T/Pos	Pol/Phase
	MHz	dBuV/m	dBuV/m	dB	dBuV	dB	dB/m	dB		cm	deg	
1	11399.94	43.71	54.00	-10.29	35.16	5.10	38.70	35.25	Average	119	70	HORIZONTAL
2	11400.32	58.83	74.00	-15.17	50.28	5.10	38.70	35.25	Peak	119	70	HORIZONTAL

### Vertical

	Freq	Level	Limit Line	Over Limit	Read Level	CableAntenna Loss	Antenna Factor	Preamp Factor	Remark	A/Pos	T/Pos	Pol/Phase
	MHz	dBuV/m	dBuV/m	dB	dBuV	dB	dB/m	dB		cm	deg	
1	11399.50	42.51	54.00	-11.49	33.96	5.10	38.70	35.25	Average	111	97	VERTICAL
2	11400.12	59.20	74.00	-14.80	50.65	5.10	38.70	35.25	Peak	111	97	VERTICAL



<b>Temperature</b>	25°C	<b>Humidity</b>	56%
<b>Test Engineer</b>	Serway Li	<b>Configurations</b>	IEEE 802.11a Ch 36 / Ant. B
<b>Test Date</b>	Jun. 15, 2012		

**Horizontal**

	Freq	Level	Limit Line	Over Limit	Read Level	CableAntenna Loss	Antenna Factor	Preamp Factor	Remark	A/Pos	T/Pos	Pol/Phase
	MHz	dBuV/m	dBuV/m	dB	dBuV	dB	dB/m	dB		cm	deg	
1	15539.84	50.16	74.00	-23.84	41.69	6.13	37.65	35.31	Peak	100	155	HORIZONTAL
2	15540.47	37.94	54.00	-16.06	29.47	6.13	37.65	35.31	Average	100	155	HORIZONTAL

**Vertical**

	Freq	Level	Limit Line	Over Limit	Read Level	CableAntenna Loss	Antenna Factor	Preamp Factor	Remark	A/Pos	T/Pos	Pol/Phase
	MHz	dBuV/m	dBuV/m	dB	dBuV	dB	dB/m	dB		cm	deg	
1	15540.38	50.83	74.00	-23.17	42.32	6.13	37.69	35.31	Peak	100	219	VERTICAL
2	15540.42	39.20	54.00	-14.80	30.69	6.13	37.69	35.31	Average	100	219	VERTICAL



<b>Temperature</b>	25°C	<b>Humidity</b>	56%
<b>Test Engineer</b>	Serway Li	<b>Configurations</b>	IEEE 802.11a Ch 40 / Ant. B
<b>Test Date</b>	Jun. 15, 2012		

**Horizontal**

	Freq	Level	Limit Line	Over Limit	Read Level	Cable Loss	Antenna Factor	Preamp Factor	Remark	A/Pos	T/Pos	Pol/Phase
	MHz	dBuV/m	dBuV/m	dB	dBuV	dB	dB/m	dB		cm	deg	
1	15599.62	38.03	54.00	-15.97	29.64	6.13	37.60	35.34	Average	100	266	HORIZONTAL
2	15600.22	50.50	74.00	-23.50	42.11	6.13	37.60	35.34	Peak	100	266	HORIZONTAL

**Vertical**

	Freq	Level	Limit Line	Over Limit	Read Level	Cable Loss	Antenna Factor	Preamp Factor	Remark	A/Pos	T/Pos	Pol/Phase
	MHz	dBuV/m	dBuV/m	dB	dBuV	dB	dB/m	dB		cm	deg	
1	15599.57	39.13	54.00	-14.87	30.74	6.13	37.60	35.34	Average	100	174	VERTICAL
2	15600.42	50.56	74.00	-23.44	42.17	6.13	37.60	35.34	Peak	100	174	VERTICAL

<b>Temperature</b>	25°C	<b>Humidity</b>	56%
<b>Test Engineer</b>	Serway Li	<b>Configurations</b>	IEEE 802.11a Ch 48 / Ant. B
<b>Test Date</b>	Jun. 15, 2012		

### Horizontal

	Freq	Level	Limit Line	Over Limit	Read Level	CableAntenna Loss	Antenna Factor	Preamp Factor	Remark	A/Pos	T/Pos	Pol/Phase
	MHz	dBuV/m	dBuV/m	dB	dBuV	dB	dB/m	dB		cm	deg	
1	15719.61	38.74	54.00	-15.26	30.51	6.14	37.48	35.39	Average	100	166	HORIZONTAL
2	15720.04	50.38	74.00	-23.62	42.15	6.14	37.48	35.39	Peak	100	166	HORIZONTAL

### Vertical

	Freq	Level	Limit Line	Over Limit	Read Level	CableAntenna Loss	Antenna Factor	Preamp Factor	Remark	A/Pos	T/Pos	Pol/Phase
	MHz	dBuV/m	dBuV/m	dB	dBuV	dB	dB/m	dB		cm	deg	
1	15719.90	51.33	74.00	-22.67	43.10	6.14	37.48	35.39	Peak	100	321	VERTICAL
2	15720.17	39.42	54.00	-14.58	31.19	6.14	37.48	35.39	Average	100	321	VERTICAL



<b>Temperature</b>	25°C	<b>Humidity</b>	56%
<b>Test Engineer</b>	Serway Li	<b>Configurations</b>	IEEE 802.11a Ch 52 / Ant. B
<b>Test Date</b>	Jun. 15, 2012		

**Horizontal**

	Freq	Level	Limit Line	Over Limit	Read Level	Cable Loss	Antenna Factor	Preamp Factor	Remark	A/Pos	T/Pos	Pol/Phase
	MHz	dBuV/m	dBuV/m	dB	dBuV	dB	dB/m	dB		cm	deg	
1	15780.17	39.23	54.00	-14.77	31.10	6.14	37.41	35.42	Average	100	132	HORIZONTAL
2	15780.25	50.08	74.00	-23.92	41.95	6.14	37.41	35.42	Peak	100	132	HORIZONTAL

**Vertical**

	Freq	Level	Limit Line	Over Limit	Read Level	Cable Loss	Antenna Factor	Preamp Factor	Remark	A/Pos	T/Pos	Pol/Phase
	MHz	dBuV/m	dBuV/m	dB	dBuV	dB	dB/m	dB		cm	deg	
1	15779.81	38.11	54.00	-15.89	29.98	6.14	37.41	35.42	Average	100	224	VERTICAL
2	15779.84	50.20	74.00	-23.80	42.07	6.14	37.41	35.42	Peak	100	224	VERTICAL



<b>Temperature</b>	25°C	<b>Humidity</b>	56%
<b>Test Engineer</b>	Serway Li	<b>Configurations</b>	IEEE 802.11a Ch 60 / Ant. B
<b>Test Date</b>	Jun. 15, 2012		

**Horizontal**

	Freq	Level	Limit Line	Over Limit	Read Level	CableAntenna Loss	Antenna Factor	Preamp Factor	Remark	A/Pos	T/Pos	Pol/Phase
	MHz	dBuV/m	dBuV/m	dB	dBuV	dB	dB/m	dB		cm	deg	
1	10600.12	45.00	54.00	-9.00	37.03	5.01	38.38	35.42	Average	148	273	HORIZONTAL
2	10600.35	59.86	74.00	-14.14	51.89	5.01	38.38	35.42	Peak	148	273	HORIZONTAL

**Vertical**

	Freq	Level	Limit Line	Over Limit	Read Level	CableAntenna Loss	Antenna Factor	Preamp Factor	Remark	A/Pos	T/Pos	Pol/Phase
	MHz	dBuV/m	dBuV/m	dB	dBuV	dB	dB/m	dB		cm	deg	
1	10600.32	43.42	54.00	-10.58	35.45	5.01	38.38	35.42	Average	122	66	VERTICAL
2	10600.32	54.33	74.00	-19.67	46.36	5.01	38.38	35.42	Peak	122	66	VERTICAL



<b>Temperature</b>	25°C	<b>Humidity</b>	56%
<b>Test Engineer</b>	Serway Li	<b>Configurations</b>	IEEE 802.11a Ch 64 / Ant. B
<b>Test Date</b>	Jun. 15, 2012		

**Horizontal**

	Freq	Level	Limit Line	Over Limit	Read Level	Cable Loss	Antenna Factor	Preamp Factor	Remark	A/Pos	T/Pos	Pol/Phase
	MHz	dBuV/m	dBuV/m	dB	dBuV	dB	dB/m	dB		cm	deg	
1	10639.44	58.22	74.00	-15.78	50.23	5.01	38.37	35.39	Peak	149	263	HORIZONTAL
2	10641.28	45.10	54.00	-8.90	37.11	5.01	38.37	35.39	Average	149	263	HORIZONTAL

**Vertical**

	Freq	Level	Limit Line	Over Limit	Read Level	Cable Loss	Antenna Factor	Preamp Factor	Remark	A/Pos	T/Pos	Pol/Phase
	MHz	dBuV/m	dBuV/m	dB	dBuV	dB	dB/m	dB		cm	deg	
1	10640.12	40.84	54.00	-13.16	32.85	5.01	38.37	35.39	Average	145	306	VERTICAL
2	10643.04	54.83	74.00	-19.17	46.84	5.01	38.37	35.39	Peak	145	306	VERTICAL





<b>Temperature</b>	25°C	<b>Humidity</b>	56%
<b>Test Engineer</b>	Serway Li	<b>Configurations</b>	IEEE 802.11a Ch 100 / Ant. B
<b>Test Date</b>	Jun. 15, 2012		

**Horizontal**

	Freq	Level	Limit Line	Over Limit	Read Level	Cable Loss	Antenna Factor	Preamp Factor	Remark	A/Pos	T/Pos	Pol/Phase
	MHz	dBuV/m	dBuV/m	dB	dBuV	dB	dB/m	dB		cm	deg	
1	11000.10	42.95	54.00	-11.05	34.72	5.01	38.32	35.10	Average	129	70	HORIZONTAL
2	11000.34	57.75	74.00	-16.25	49.52	5.01	38.32	35.10	Peak	129	70	HORIZONTAL

**Vertical**

	Freq	Level	Limit Line	Over Limit	Read Level	Cable Loss	Antenna Factor	Preamp Factor	Remark	A/Pos	T/Pos	Pol/Phase
	MHz	dBuV/m	dBuV/m	dB	dBuV	dB	dB/m	dB		cm	deg	
1	10999.93	57.23	74.00	-16.77	49.02	5.01	38.30	35.10	Peak	123	287	VERTICAL
2	11000.15	42.81	54.00	-11.19	34.60	5.01	38.30	35.10	Average	123	287	VERTICAL



<b>Temperature</b>	25°C	<b>Humidity</b>	56%
<b>Test Engineer</b>	Serway Li	<b>Configurations</b>	IEEE 802.11a Ch 116 / Ant. B
<b>Test Date</b>	Jun. 15, 2012		

**Horizontal**

	Freq	Level	Limit Line	Over Limit	Read Level	Cable Loss	Antenna Factor	Preamp Factor	Remark	A/Pos	T/Pos	Pol/Phase
	MHz	dBuV/m	dBuV/m	dB	dBuV	dB	dB/m	dB		cm	deg	
1	11159.50	50.04	54.00	-3.96	41.70	5.04	38.47	35.17	Average	117	70	HORIZONTAL
2	11159.65	64.74	74.00	-9.26	56.40	5.04	38.47	35.17	Peak	117	70	HORIZONTAL

**Vertical**

	Freq	Level	Limit Line	Over Limit	Read Level	Cable Loss	Antenna Factor	Preamp Factor	Remark	A/Pos	T/Pos	Pol/Phase
	MHz	dBuV/m	dBuV/m	dB	dBuV	dB	dB/m	dB		cm	deg	
1	11158.80	66.81	74.00	-7.19	58.47	5.04	38.47	35.17	Peak	119	288	VERTICAL
2	11159.04	51.90	54.00	-2.10	43.56	5.04	38.47	35.17	Average	119	288	VERTICAL



<b>Temperature</b>	25°C	<b>Humidity</b>	56%
<b>Test Engineer</b>	Serway Li	<b>Configurations</b>	IEEE 802.11a Ch 140 / Ant. B
<b>Test Date</b>	Jun. 15, 2012		

**Horizontal**

	Freq	Level	Limit Line	Over Limit	Read Level	Cable Loss	Antenna Factor	Preamp Factor	Remark	A/Pos	T/Pos	Pol/Phase
	MHz	dBuV/m	dBuV/m	dB	dBuV	dB	dB/m	dB		cm	deg	
1	11399.60	56.80	74.00	-17.20	48.25	5.10	38.70	35.25	Peak	115	67	HORIZONTAL
2	11400.14	42.61	54.00	-11.39	34.06	5.10	38.70	35.25	Average	115	67	HORIZONTAL

**Vertical**

	Freq	Level	Limit Line	Over Limit	Read Level	Cable Loss	Antenna Factor	Preamp Factor	Remark	A/Pos	T/Pos	Pol/Phase
	MHz	dBuV/m	dBuV/m	dB	dBuV	dB	dB/m	dB		cm	deg	
1	11399.55	59.09	74.00	-14.91	50.54	5.10	38.70	35.25	Peak	119	294	VERTICAL
2	11400.13	42.53	54.00	-11.47	33.98	5.10	38.70	35.25	Average	119	294	VERTICAL

**Note:**

The amplitude of spurious emissions that are attenuated by more than 20dB below the permissible value has no need to be reported.

Emission level (dBuV/m) = 20 log Emission level (uV/m).

Corrected Reading: Antenna Factor + Cable Loss + Read Level - Preamp Factor = Level.

## 4.7. Band Edge Emissions Measurement

### 4.7.1. Limit

For transmitters operating in the 5.15-5.35 GHz band: all emissions outside of the 5.15-5.35 GHz band shall not exceed an EIRP of -27 dBm/MHz (68.3dBuV/m at 3m). For transmitters operating in the 5.470-5.725 GHz band: all emissions outside of the 5.470-5.725 GHz band shall not exceed an EIRP of -27 dBm/MHz (68.3dBuV/m at 3m). For transmitters operating in the 5.725-5.825 GHz band: all emissions within the frequency range from the band edge to 10 MHz above or below the band edge shall not exceed an EIRP of -17 dBm/MHz (78.3dBuV/m at 3m); for frequencies 10 MHz or greater above or below the band edge, emissions shall not exceed an EIRP of -27 dBm/MHz (68.3dBuV/m at 3m). In addition, in case the emission falls within the restricted band specified on 15.205(a), then the 15.209(a) limit in the table below has to be followed.

Frequencies (MHz)	Field Strength (micovolts/meter)	Measurement Distance (meters)
0.009~0.490	2400/F(KHz)	300
0.490~1.705	24000/F(KHz)	30
1.705~30.0	30	30
30~88	100	3
88~216	150	3
216~960	200	3
Above 960	500	3

### 4.7.2. Measuring Instruments and Setting

Please refer to section 5 of equipments list in this report. The following table is the setting of the spectrum analyzer.

Spectrum Parameter	Setting
Attenuation	Auto
Span Frequency	100 MHz
RB / VB (Emission in restricted band)	1 MHz / 3MHz for Peak, 1 MHz / 10Hz for Average
RB / VB (Emission in non-restricted band)	1 MHz / 3MHz for Peak

### 4.7.3. Test Procedures

The test procedure is the same as section 4.6.3, only the frequency range investigated is limited to 100MHz around bandedges.

#### **4.7.4. Test Setup Layout**

This test setup layout is the same as that shown in section 4.6.4.

#### **4.7.5. Test Deviation**

There is no deviation with the original standard.

#### **4.7.6. EUT Operation during Test**

The EUT was programmed to be in continuously transmitting mode.

#### 4.7.7. Test Result of Band Edge and Fundamental Emissions

<b>Temperature</b>	25.6°C	<b>Humidity</b>	56%
<b>Test Engineer</b>	Serway Li	<b>Configurations</b>	IEEE 802.11n MCS0 20MHz Ch 36, 40 / Ant. B
<b>Test Date</b>	Jun. 15, 2012		

##### Channel 36

	Freq	Level	Limit Line	Over Limit	Read Level	CableAntenna Loss	Antenna Factor	Preamp Factor	Remark	A/Pos	T/Pos	PoI/Phase
	MHz	dBuV/m	dBuV/m	dB	dBuV	dB	dB/m	dB		cm	deg	
1	5148.60	71.24	74.00	-2.76	34.14	3.43	33.67	0.00	Peak	113	150	VERTICAL
2	5150.00	48.46	54.00	-5.54	11.36	3.43	33.67	0.00	Average	113	150	VERTICAL
3	5180.60				56.62	3.44	33.73	0.00	Average	113	150	VERTICAL
4	5180.60				70.35	3.44	33.73	0.00	Peak	113	150	VERTICAL

Item 3, 4 are the fundamental frequency at 5180 MHz.

##### Channel 40

	Freq	Level	Limit Line	Over Limit	Read Level	CableAntenna Loss	Antenna Factor	Preamp Factor	Remark	A/Pos	T/Pos	PoI/Phase
	MHz	dBuV/m	dBuV/m	dB	dBuV	dB	dB/m	dB		cm	deg	
1	5150.00	48.51	54.00	-5.49	11.41	3.43	33.67	0.00	Average	109	150	VERTICAL
2	5150.00	67.76	74.00	-6.24	30.66	3.43	33.67	0.00	Peak	109	150	VERTICAL
3	5199.20				58.67	3.45	33.76	0.00	Average	109	150	VERTICAL
4	5200.80				71.81	3.45	33.76	0.00	Peak	109	150	VERTICAL
5	5359.60	45.73	54.00	-8.27	8.21	3.49	34.03	0.00	Average	109	150	VERTICAL
6	5359.60	58.06	74.00	-15.94	20.54	3.49	34.03	0.00	Peak	109	150	VERTICAL

Item 3, 4 are the fundamental frequency at 5200 MHz.

<b>Temperature</b>	25.6°C	<b>Humidity</b>	56%
<b>Test Engineer</b>	Serway Li	<b>Configurations</b>	IEEE 802.11n MCS0 20MHz Ch 48, 52 / Ant. B
<b>Test Date</b>	Jun. 15, 2012		

### Channel 48

	Freq	Level	Limit	Over	Read	CableAntenna	Preamp	Remark	A/Pos	T/Pos	Pol/Phase
	MHz	dBuV/m	dBuV/m	dB	dBuV	dB	dB/m	dB	cm	deg	
1	5079.60	43.98	54.00	-10.02	7.02	3.41	33.55	0.00 Average	100	152	VERTICAL
2	5086.00	54.09	74.00	-19.91	17.13	3.41	33.55	0.00 Peak	100	152	VERTICAL
3	5239.20				58.88	3.46	33.82	0.00 Average	100	152	VERTICAL
4	5240.00				72.15	3.46	33.82	0.00 Peak	100	152	VERTICAL
5	5399.60	46.59	54.00	-7.41	8.96	3.51	34.12	0.00 Average	100	152	VERTICAL
6	5399.60	58.88	74.00	-15.12	21.25	3.51	34.12	0.00 Peak	100	152	VERTICAL

Item 3, 4 are the fundamental frequency at 5240 MHz.

### Channel 52

	Freq	Level	Limit	Over	Read	CableAntenna	Preamp	Remark	A/Pos	T/Pos	Pol/Phase
	MHz	dBuV/m	dBuV/m	dB	dBuV	dB	dB/m	dB	cm	deg	
1	5099.60	46.33	54.00	-7.67	9.33	3.42	33.58	0.00 Average	100	152	VERTICAL
2	5107.60	55.48	74.00	-18.52	18.48	3.42	33.58	0.00 Peak	100	152	VERTICAL
3	5259.20				57.75	3.46	33.85	0.00 Average	100	152	VERTICAL
4	5259.20				70.12	3.46	33.85	0.00 Peak	100	152	VERTICAL
5	5420.00	44.86	54.00	-9.14	7.20	3.51	34.15	0.00 Average	100	152	VERTICAL
6	5428.00	55.59	74.00	-18.41	17.92	3.52	34.15	0.00 Peak	100	152	VERTICAL

Item 3, 4 are the fundamental frequency at 5260 MHz.



<b>Temperature</b>	25.6°C	<b>Humidity</b>	56%
<b>Test Engineer</b>	Serway Li	<b>Configurations</b>	IEEE 802.11n MCS0 20MHz Ch 60, 64 / Ant. B
<b>Test Date</b>	Jun. 15, 2012		

**Channel 60**

	Freq	Level	Limit Line	Over Limit	Read Level	CableAntenna Loss	Antenna Factor	Preamp Factor	Remark	A/Pos	T/Pos	Pol/Phase
	MHz	dBuV/m	dBuV/m	dB	dBuV	dB	dB/m	dB		cm	deg	
1	5138.80	46.99	54.00	-7.01	9.92	3.43	33.64	0.00	Average	100	145	VERTICAL
2	5139.60	56.53	74.00	-17.47	19.46	3.43	33.64	0.00	Peak	100	145	VERTICAL
3	5300.00				69.37	3.48	33.94	0.00	Peak	100	145	VERTICAL
4	5300.80				56.33	3.48	33.94	0.00	Average	100	145	VERTICAL
5	5460.00	43.07	54.00	-10.93	5.34	3.52	34.21	0.00	Average	100	145	VERTICAL
6	5460.00	54.02	74.00	-19.98	16.29	3.52	34.21	0.00	Peak	100	145	VERTICAL

Item 3, 4 are the fundamental frequency at 5300 MHz.

**Channel 64**

	Freq	Level	Limit Line	Over Limit	Read Level	CableAntenna Loss	Antenna Factor	Preamp Factor	Remark	A/Pos	T/Pos	Pol/Phase
	MHz	dBuV/m	dBuV/m	dB	dBuV	dB	dB/m	dB		cm	deg	
1	5319.20				69.88	3.48	33.97	0.00	Peak	100	147	VERTICAL
2	5319.40				56.68	3.48	33.97	0.00	Average	100	147	VERTICAL
3	5350.00	47.56	54.00	-6.44	10.04	3.49	34.03	0.00	Average	100	147	VERTICAL
4	5350.00	66.69	74.00	-7.31	29.17	3.49	34.03	0.00	Peak	100	147	VERTICAL

Item 1, 2 are the fundamental frequency at 5320 MHz.



<b>Temperature</b>	25.6°C	<b>Humidity</b>	56%
<b>Test Engineer</b>	Serway Li	<b>Configurations</b>	IEEE 802.11n MCS0 20MHz Ch 100, 140 / Ant. B
<b>Test Date</b>	Jun. 15, 2012		

**Channel 100**

	Freq	Level	Limit Line	Over Limit	Read Level	CableAntenna Loss	Antenna Factor	Preamp Factor	Remark	A/Pos	T/Pos	Pol/Phase
	MHz	dBuV/m	dBuV/m	dB	dBuV	dB	dB/m	dB		cm	deg	
1	5459.80	54.65	74.00	-19.35	16.92	3.52	34.21	0.00	Peak	100	149	VERTICAL
2	5460.00	41.53	54.00	-12.47	3.80	3.52	34.21	0.00	Average	100	149	VERTICAL
3	5469.80	63.73	68.30	-4.57	25.97	3.52	34.24	0.00	Peak	100	149	VERTICAL
4	5499.80				66.14	3.53	34.26	0.00	Peak	100	149	VERTICAL
5	5500.60				53.21	3.53	34.26	0.00	Average	100	149	VERTICAL

Item 4, 5 are the fundamental frequency at 5500 MHz.

**Channel 140**

	Freq	Level	Limit Line	Over Limit	Read Level	CableAntenna Loss	Antenna Factor	Preamp Factor	Remark	A/Pos	T/Pos	Pol/Phase
	MHz	dBuV/m	dBuV/m	dB	dBuV	dB	dB/m	dB		cm	deg	
1	5699.20				54.36	3.59	34.34	0.00	Average	100	149	VERTICAL
2	5699.60				67.46	3.59	34.34	0.00	Peak	100	149	VERTICAL
3	5725.40	67.35	68.30	-0.95	29.41	3.60	34.34	0.00	Peak	100	149	VERTICAL

Item 1, 2 are the fundamental frequency at 5700 MHz.

<b>Temperature</b>	25.6°C	<b>Humidity</b>	56%
<b>Test Engineer</b>	Serway Li	<b>Configurations</b>	IEEE 802.11a Ch 36, 40 / Ant. B
<b>Test Date</b>	Jun. 15, 2012		

**Channel 36**

	Freq	Level	Limit Line	Over Limit	Read Level	CableAntenna Loss	Antenna Factor	Preamp Factor	Remark	A/Pos	T/Pos	Pol/Phase
	MHz	dBuV/m	dBuV/m	dB	dBuV	dB	dB/m	dB		cm	deg	
1	5148.60	71.67	74.00	-2.33	34.57	3.43	33.67	0.00	Peak	206	255	HORIZONTAL
2	5150.00	48.92	54.00	-5.08	11.82	3.43	33.67	0.00	Average	206	255	HORIZONTAL
3	5180.60				59.05	3.44	33.73	0.00	Average	206	255	HORIZONTAL
4	5181.60				72.15	3.44	33.73	0.00	Peak	206	255	HORIZONTAL

Item 3, 4 are the fundamental frequency at 5180 MHz.

**Channel 40**

	Freq	Level	Limit Line	Over Limit	Read Level	CableAntenna Loss	Antenna Factor	Preamp Factor	Remark	A/Pos	T/Pos	Pol/Phase
	MHz	dBuV/m	dBuV/m	dB	dBuV	dB	dB/m	dB		cm	deg	
1	5038.80	55.72	74.00	-18.28	18.87	3.40	33.45	0.00	Peak	203	267	HORIZONTAL
2	5039.60	47.14	54.00	-6.86	10.29	3.40	33.45	0.00	Average	203	267	HORIZONTAL
3	5200.80				59.98	3.45	33.76	0.00	Average	203	267	HORIZONTAL
4	5200.80				72.41	3.45	33.76	0.00	Peak	203	267	HORIZONTAL
5	5359.60	49.21	54.00	-4.79	11.69	3.49	34.03	0.00	Average	203	267	HORIZONTAL
6	5359.60	60.90	74.00	-13.10	23.38	3.49	34.03	0.00	Peak	203	267	HORIZONTAL

Item 3, 4 are the fundamental frequency at 5200 MHz.



<b>Temperature</b>	25.6°C	<b>Humidity</b>	56%
<b>Test Engineer</b>	Serway Li	<b>Configurations</b>	IEEE 802.11a Ch 48, 52 / Ant. B
<b>Test Date</b>	Jun. 15, 2012		

**Channel 48**

	Freq	Level	Limit	Over	Read	Cable	Antenna	Preamp	Remark	A/Pos	T/Pos	Pol/Phase
	MHz	dBuV/m	dBuV/m	dB	dBuV	dB	dB/m	dB		cm	deg	
1	5078.80	53.85	74.00	-20.15	16.89	3.41	33.55	0.00	Peak	235	55	HORIZONTAL
2	5079.60	43.80	54.00	-10.20	6.84	3.41	33.55	0.00	Average	235	55	HORIZONTAL
3	5239.20				58.38	3.46	33.82	0.00	Average	235	55	HORIZONTAL
4	5239.20				70.91	3.46	33.82	0.00	Peak	235	55	HORIZONTAL
5	5399.60	45.69	54.00	-8.31	8.06	3.51	34.12	0.00	Average	235	55	HORIZONTAL
6	5400.40	55.14	74.00	-18.86	17.51	3.51	34.12	0.00	Peak	235	55	HORIZONTAL

Item 3, 4 are the fundamental frequency at 5240 MHz.

**Channel 52**

	Freq	Level	Limit	Over	Read	Cable	Antenna	Preamp	Remark	A/Pos	T/Pos	Pol/Phase
	MHz	dBuV/m	dBuV/m	dB	dBuV	dB	dB/m	dB		cm	deg	
1	5099.60	47.45	54.00	-6.55	10.45	3.42	33.58	0.00	Average	207	263	HORIZONTAL
2	5099.60	57.64	74.00	-16.36	20.64	3.42	33.58	0.00	Peak	207	263	HORIZONTAL
3	5259.20				58.39	3.46	33.85	0.00	Average	207	263	HORIZONTAL
4	5260.00				71.18	3.46	33.85	0.00	Peak	207	263	HORIZONTAL
5	5419.60	48.42	54.00	-5.58	10.76	3.51	34.15	0.00	Average	207	263	HORIZONTAL
6	5420.40	56.88	74.00	-17.12	19.22	3.51	34.15	0.00	Peak	207	263	HORIZONTAL

Item 3, 4 are the fundamental frequency at 5260 MHz.



<b>Temperature</b>	25.6°C	<b>Humidity</b>	56%
<b>Test Engineer</b>	Serway Li	<b>Configurations</b>	IEEE 802.11a Ch 60, 64 / Ant. B
<b>Test Date</b>	Jun. 15, 2012		

**Channel 60**

	Freq	Level	Limit Line	Over Limit	Read Level	Cable Loss	Antenna Factor	Preamp Factor	Remark	A/Pos	T/Pos	Pol/Phase
	MHz	dBuV/m	dBuV/m	dB	dBuV	dB	dB/m	dB		cm	deg	
1	5139.60	47.90	54.00	-6.10	10.83	3.43	33.64	0.00	Average	211	259	HORIZONTAL
2	5139.60	58.44	74.00	-15.56	21.37	3.43	33.64	0.00	Peak	211	259	HORIZONTAL
3	5299.20				58.29	3.48	33.94	0.00	Average	211	259	HORIZONTAL
4	5300.80				71.27	3.48	33.94	0.00	Peak	211	259	HORIZONTAL
5	5459.60	48.47	54.00	-5.53	10.76	3.52	34.19	0.00	Average	211	259	HORIZONTAL
6	5460.80	59.14	68.30	-9.16	21.43	3.52	34.19	0.00	Peak	211	259	HORIZONTAL

Item 3, 4 are the fundamental frequency at 5300 MHz.

**Channel 64**

	Freq	Level	Limit Line	Over Limit	Read Level	Cable Loss	Antenna Factor	Preamp Factor	Remark	A/Pos	T/Pos	Pol/Phase
	MHz	dBuV/m	dBuV/m	dB	dBuV	dB	dB/m	dB		cm	deg	
1	5319.20				59.22	3.48	33.97	0.00	Average	172	254	HORIZONTAL
2	5320.00				71.67	3.48	33.97	0.00	Peak	172	254	HORIZONTAL
3	5350.00	49.78	54.00	-4.22	12.26	3.49	34.03	0.00	Average	172	254	HORIZONTAL
4	5350.00	72.72	74.00	-1.28	35.20	3.49	34.03	0.00	Peak	172	254	HORIZONTAL

Item 1, 2 are the fundamental frequency at 5320 MHz.



<b>Temperature</b>	25.6°C	<b>Humidity</b>	56%
<b>Test Engineer</b>	Serway Li	<b>Configurations</b>	IEEE 802.11a Ch 100, 140 / Ant. B
<b>Test Date</b>	Jun. 15, 2012		

**Channel 100**

	Freq	Level	Limit Line	Over Limit	Read Level	Cable Loss	Antenna Factor	Preamp Factor	Remark	A/Pos	T/Pos	Pol/Phase
	MHz	dBuV/m	dBuV/m	dB	dBuV	dB	dB/m	dB		cm	deg	
1	5459.60	60.62	74.00	-13.38	22.91	3.52	34.19	0.00	Peak	192	251	HORIZONTAL
2	5460.00	43.94	54.00	-10.06	6.23	3.52	34.19	0.00	Average	192	251	HORIZONTAL
3	5469.60	67.48	68.30	-0.82	29.75	3.52	34.21	0.00	Peak	192	251	HORIZONTAL
4	5498.80				70.55	3.53	34.23	0.00	Peak	192	251	HORIZONTAL
5	5499.60				57.78	3.53	34.23	0.00	Average	192	251	HORIZONTAL

Item 4, 5 are the fundamental frequency at 5500 MHz.

**Channel 140**

	Freq	Level	Limit Line	Over Limit	Read Level	Cable Loss	Antenna Factor	Preamp Factor	Remark	A/Pos	T/Pos	Pol/Phase
	MHz	dBuV/m	dBuV/m	dB	dBuV	dB	dB/m	dB		cm	deg	
1	5699.40				57.38	3.59	34.34	0.00	Average	195	247	HORIZONTAL
2	5700.00				71.71	3.59	34.34	0.00	Peak	195	247	HORIZONTAL
3	5726.00	67.77	68.30	-0.53	29.83	3.60	34.34	0.00	Peak	195	247	HORIZONTAL

Item 1, 2 are the fundamental frequency at 5700 MHz.

Note:

Emission level (dBuV/m) = 20 log Emission level (uV/m)

Corrected Reading: Antenna Factor + Cable Loss + Read Level - Preamp Factor = Level

## 4.8. Frequency Stability Measurement

### 4.8.1. Limit

Manufacturers of U-NII devices are responsible for ensuring frequency stability such that an emissions is maintained within the band of operation under all conditions of normal operation as specified in the user's manual or  $\pm 20\text{ppm}$  (IEEE 802.11 specification).

### 4.8.2. Measuring Instruments and Setting

Please refer to section 5 of equipments list in this report. The following table is the setting of the spectrum analyzer.

Spectrum Parameter	Setting
Attenuation	Auto
Span Frequency	Entire absence of modulation emissions bandwidth
RB	10 kHz
VB	10 kHz
Sweep Time	Auto

### 4.8.3. Test Procedures

1. The transmitter output (antenna port) was connected to the spectrum analyzer.
2. EUT have transmitted absence of modulation signal and fixed channelize.
3. Set the spectrum analyzer span to view the entire absence of modulation emissions bandwidth.
4. Set RBW = 10 kHz, VBW = 10 kHz with peak detector and maxhold settings.
5.  $f_c$  is declaring of channel frequency. Then the frequency error formula is  $(f_c - f)/f_c \times 10^6$  ppm and the limit is less than  $\pm 20\text{ppm}$  (IEEE 802.11 specification).
6. The test extreme voltage is to change the primary supply voltage from 85 to 115 percent of the nominal value
7. Extreme temperature rule is  $-30^\circ\text{C} \sim 50^\circ\text{C}$ .

### 4.8.4. Test Setup Layout

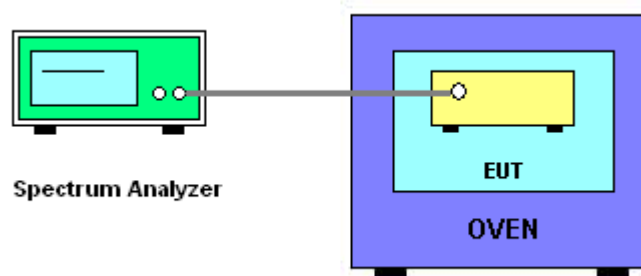

#### 4.8.5. Test Deviation

There is no deviation with the original standard.

#### 4.8.6. EUT Operation during Test

The EUT was programmed to be in continuously un-modulation transmitting mode.

#### 4.8.7. Test Result of Frequency Stability

##### Voltage vs. Frequency Stability

Voltage	Measurement Frequency (MHz)	
	5200	5300
(V)		
126.50	5199.9843	5299.9844
110.00	5199.9868	5299.9856
93.50	5200.0030	5300.0050
Max. Deviation (MHz)	0.015700	0.015600
Max. Deviation (ppm)	<b>3.02</b>	<b>2.94</b>

##### Temperature vs. Frequency Stability

Temperature	Measurement Frequency (MHz)	
	5200	5300
(°C)		
-30	5199.9816	5299.9811
-20	5199.9823	5299.9821
-10	5199.9833	5299.9826
0	5199.9841	5299.9831
10	5199.9852	5299.9848
20	5199.9868	5299.9856
30	5199.9913	5299.9871
40	5199.9926	5299.9878
50	5199.9938	5299.9891
Max. Deviation (MHz)	0.018400	0.018900
Max. Deviation (ppm)	<b>3.54</b>	<b>3.5660</b>

## 4.9. Antenna Requirements

### 4.9.1 Limit

Except for special regulations, the Low-power Radio-frequency Devices must not be equipped with any jacket for installing an antenna with extension cable. An intentional radiator shall be designed to ensure that no antenna other than that furnished by the responsible party shall be used with the device. The use of a permanently attached antenna or of an antenna that uses a unique coupling to the intentional radiator shall be considered sufficient to comply with the provisions of this Section. The manufacturer may design the unit so that the user can replace a broken antenna, but the use of a standard antenna jack or electrical connector is prohibited. Further, this requirement does not apply to intentional radiators that must be professionally installed.

### 4.9.2. Antenna Connector Construction

Please refer to section 3.3 in this test report; antenna connector complied with the requirements.



## 5. LIST OF MEASURING EQUIPMENTS

Instrument	Manufacturer	Model No.	Serial No.	Characteristics	Calibration Date	Remark
EMI Test Receiver	R&S	ESCS 30	100377	9kHz ~ 2.75GHz	Sep. 14, 2011	Conduction (CO01-CB)
LISN	F.C.C.	FCC-LISN-50-16-2	04083	150kHz ~ 100MHz	Nov. 14, 2011	Conduction (CO01-CB)
V- LISN	Schwarzbeck	NSLK 8127	8127-478	9K ~ 30MHz	Jun. 22, 2012	Conduction (CO01-CB)
PULSE LIMITER	R&S	ESH3-Z2	100430	9K~30MHz	Feb. 03, 2012	Conduction (CO01-CB)
COND Cable	Woken	Cable	01	0.15MHz~30MHz	Dec. 4, 2011	Conduction (CO01-CB)
BILOG ANTENNA	Schaffner	CBL6112D	22021	20MHz ~ 2GHz	Jan. 11, 2012	Radiation (03CH01-CB)
Horn Antenna	EMCO	3115	00075790	750MHz~18GHz	Nov. 25, 2011	Radiation (03CH01-CB)
Horn Antenna	SCHWARZBEAK	BBHA 9170	BBHA9170252	15GHz ~ 40GHz	Nov. 22, 2011	Radiation (03CH01-CB)
Pre-Amplifier	Agilent	8447D	2944A10991	0.1MHz ~ 1.3GHz	Nov. 17, 2011	Radiation (03CH01-CB)
Pre-Amplifier	Agilent	8449B	3008A02310	1GHz ~ 26.5GHz	Nov. 29, 2011	Radiation (03CH01-CB)
Pre-Amplifier	WM	TF-130N-R1	923365	26.5GHz ~ 40GHz	Jul. 29, 2011	Radiation (03CH01-CB)
Spectrum analyzer	R&S	FSP40	100056	9KHz~40GHz	Nov. 03, 2011	Radiation (05CH01-CB)
EMI Test Receiver	R&S	ESCS 30	100355	9KHz ~ 2.75GHz	Mar. 20, 2012	Radiation (03CH01-CB)
Loop Antenna	Teseq	HLA 6120	24155	9 kHz - 30 MHz	Sep. 09, 2010*	Radiation (03CH01-CB)
Turn Table	INN CO	CO 2000	N/A	0 ~ 360 degree	N/A	Radiation (03CH01-CB)
Antenna Mast	INN CO	CO2000	N/A	1 m - 4 m	N/A	Radiation (03CH01-CB)
RF Cable-low	Woken	Low Cable-1	N/A	30 MHz - 1 GHz	Nov. 17, 2011	Radiation (03CH01-CB)
RF Cable-high	Woken	High Cable-1	N/A	1 GHz – 26.5 GHz	Nov. 17, 2011	Radiation (03CH01-CB)
RF Cable-high	Woken	High Cable-2	N/A	1 GHz – 26.5 GHz	Nov. 17, 2011	Radiation (03CH01-CB)
RF Cable-high	Woken	High Cable-3	N/A	1 GHz - 40 GHz	Nov. 17, 2011	Radiation (03CH01-CB)
RF Cable-high	Woken	High Cable-4	N/A	1 GHz - 40 GHz	Nov. 17, 2011	Radiation (03CH01-CB)
Signal analyzer	R&S	FSV40	100979	9KHz~40GHz	Sep. 26, 2011	Conducted (TH01-CB)
Temp. and Humidity Chamber	Ten Billion	TTH-D3SP	TBN-931011	-30~100 degree	Jun. 05, 2012	Conducted (TH01-CB)
Thermo-Hygro Meter	N/A	HC 520	#1	15~70 degree	Nov. 02, 2011	Conducted (TH01-CB)
Signal Generator	R&S	SMR40	100302	10MHz-40GHz	Nov. 22, 2011	Conducted (TH01-CB)

Instrument	Manufacturer	Model No.	Serial No.	Characteristics	Calibration Date	Remark
RF Power Divider	HP	11636A	00306	2GHz ~ 18GHz	N/A	Conducted (TH01-CB)
RF Power Splitter	Anaren	44100	1839	2GHz ~ 18GHz	N/A	Conducted (TH01-CB)
RF Power Splitter	Anaren	42100	17930	2GHz ~ 18GHz	N/A	Conducted (TH01-CB)
Signal generator	R&S	SMU200A	102782	10MHz-40GHz	Jun. 07, 2012	Conducted (TH01-CB)
Horn Antenna	COM-POWER	AH-118	071187	1GHz – 18GHz	May 09, 2012	Conducted (TH01-CB)
RF Cable-high	Woken	High Cable-7	-	1 GHz – 26.5 GHz	Nov. 17, 2011	Conducted (TH01-CB)
RF Cable-high	Woken	High Cable-8	-	1 GHz – 26.5 GHz	Nov. 17, 2011	Conducted (TH01-CB)
RF Cable-high	Woken	High Cable-9	-	1 GHz – 26.5 GHz	Nov. 17, 2011	Conducted (TH01-CB)
RF Cable-high	Woken	High Cable-10	-	1 GHz – 26.5 GHz	Nov. 17, 2011	Conducted (TH01-CB)
RF Cable-high	Woken	High Cable-11	-	1 GHz – 26.5 GHz	Nov. 17, 2011	Conducted (TH01-CB)
RF Cable-high	Woken	High Cable-12	-	1 GHz – 26.5 GHz	Nov. 17, 2011	Conducted (TH01-CB)
RF Cable-high	Woken	High Cable-13	-	1 GHz – 26.5 GHz	Nov. 17, 2011	Conducted (TH01-CB)
Power Sensor	Anritsu	MA2411B	0917223	300MHz~40GHz	Nov. 01, 2011	Conducted (TH01-CB)
Power Meter	Anritsu	ML2495A	1035008	300MHz~40GHz	Nov. 01, 2011	Conducted (TH01-CB)

Note: Calibration Interval of instruments listed above is one year.

“\*” Calibration Interval of instruments listed above is two years.

NCR means Non-Calibration required.

## 6. TEST LOCATION

SHIJR	ADD : 6Fl., No. 106, Sec. 1, Shintai 5th Rd., Shijr City, Taipei, Taiwan 221, R.O.C. TEL : 886-2-2696-2468 FAX : 886-2-2696-2255
HWA YA	ADD : No. 52, Hwa Ya 1st Rd., Kwei-Shan Hsiang, Tao Yuan Hsien, Taiwan, R.O.C. TEL : 886-3-327-3456 FAX : 886-3-318-0055
LINKOU	ADD : No. 30-2, Dingfu Tsuen, Linkou Shiang, Taipei, Taiwan 244, R.O.C TEL : 886-2-2601-1640 FAX : 886-2-2601-1695
DUNGHU	ADD : No. 3, Lane 238, Kangle St., Neihu Chiu, Taipei, Taiwan 114, R.O.C. TEL : 886-2-2631-4739 FAX : 886-2-2631-9740
JUNGHE	ADD : 7Fl., No. 758, Jungjeng Rd., Junghe City, Taipei, Taiwan 235, R.O.C. TEL : 886-2-8227-2020 FAX : 886-2-8227-2626
NEIHU	ADD : 4Fl., No. 339, Hsin Hu 2 <sup>nd</sup> Rd., Taipei 114, Taiwan, R.O.C. TEL : 886-2-2794-8886 FAX : 886-2-2794-9777
JHUBEI	ADD : No.8, Lane 724, Bo-ai St., Jhubei City, HsinChu County 302, Taiwan, R.O.C. TEL : 886-3-656-9065 FAX : 886-3-656-9085

## 7. TAF CERTIFICATE OF ACCREDITATION



Certificate No. : L1190-110702

財團法人全國認證基金會  
Taiwan Accreditation Foundation

### Certificate of Accreditation

This is to certify that

**Sporton International Inc.**  
**EMC & Wireless Communications Laboratory**  
No.52, Hwa Ya 1st Road, Hwa Ya Technology Park, Kwei-Shan Hsiang, Tao Yuan Hsien,  
Taiwan, R.O.C.

**is accredited in respect of laboratory**

<b>Accreditation Criteria</b>	: ISO/IEC 17025:2005
<b>Accreditation Number</b>	: 1190
<b>Originally Accredited</b>	: December 15, 2003
<b>Effective Period</b>	: January 10, 2010 to January 09, 2013
<b>Accredited Scope</b>	: Testing Field, see described in the Appendix
<b>Specific Accreditation Program</b>	: Accreditation Program for Designated Testing Laboratory for Commodities Inspection Accreditation Program for Telecommunication Equipment Testing Laboratory Accreditation Program for BSMI Mutual Recognition Arrangement with Foreign Authorities

  
Jay-San Chen  
President, Taiwan Accreditation Foundation  
Date : July 02, 2011

P1, total 22 pages

The Appendix forms an integral part of this Certificate, which shall be invalid when use without the Appendix

## Appendix A. Test Photos

## 1. Photographs of Conducted Emissions Test Configuration

FRONT VIEW



REAR VIEW

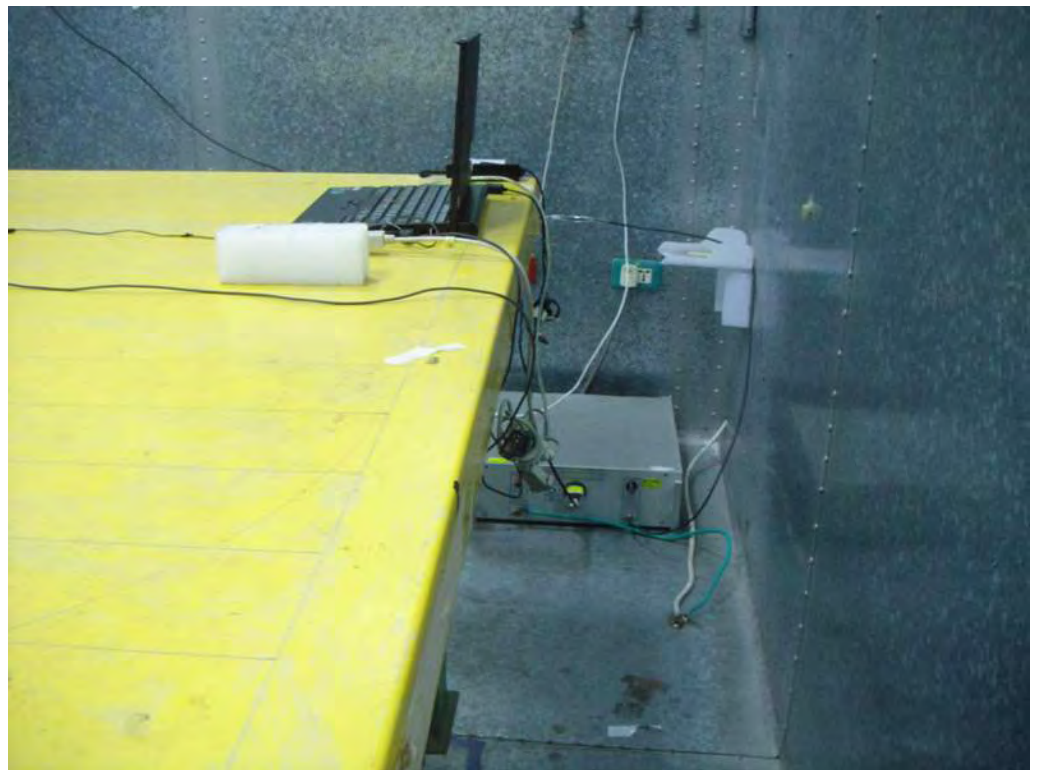

## 2. Photographs of Radiated Emissions Test Configuration

Test Configuration: 9kHz ~30MHz

FRONT VIEW



REAR VIEW



Test Configuration: 30MHz~1GHz

FRONT VIEW



REAR VIEW





Test Configuration: Above 1GHz

FRONT VIEW

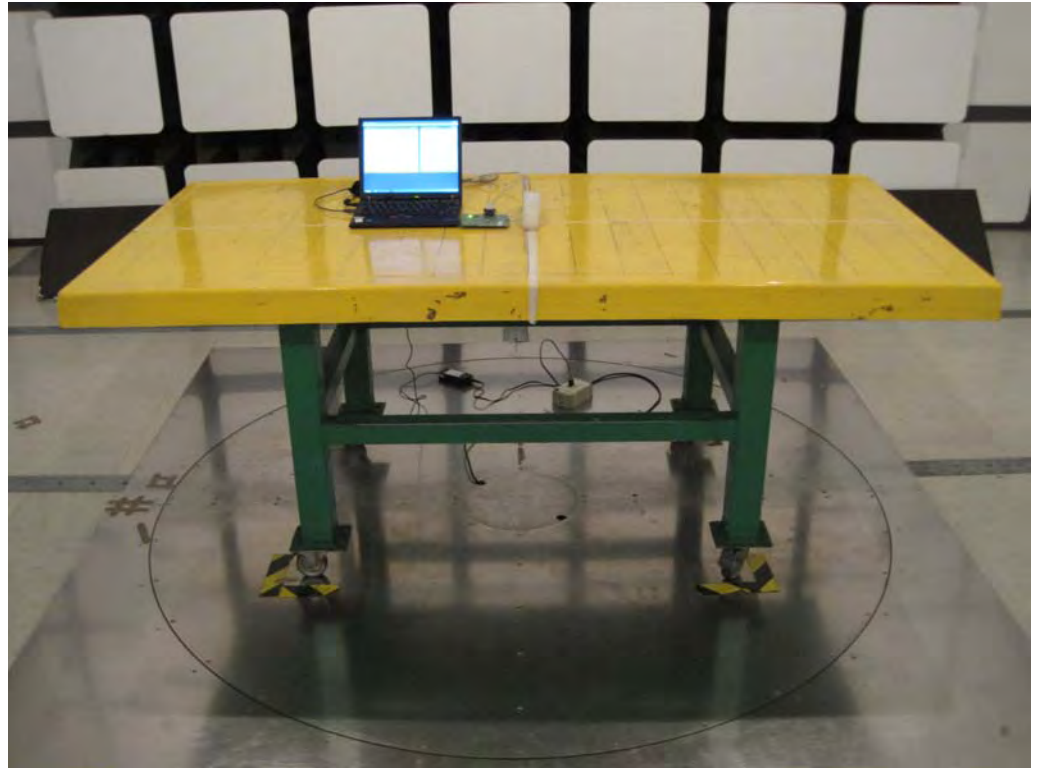

REAR VIEW

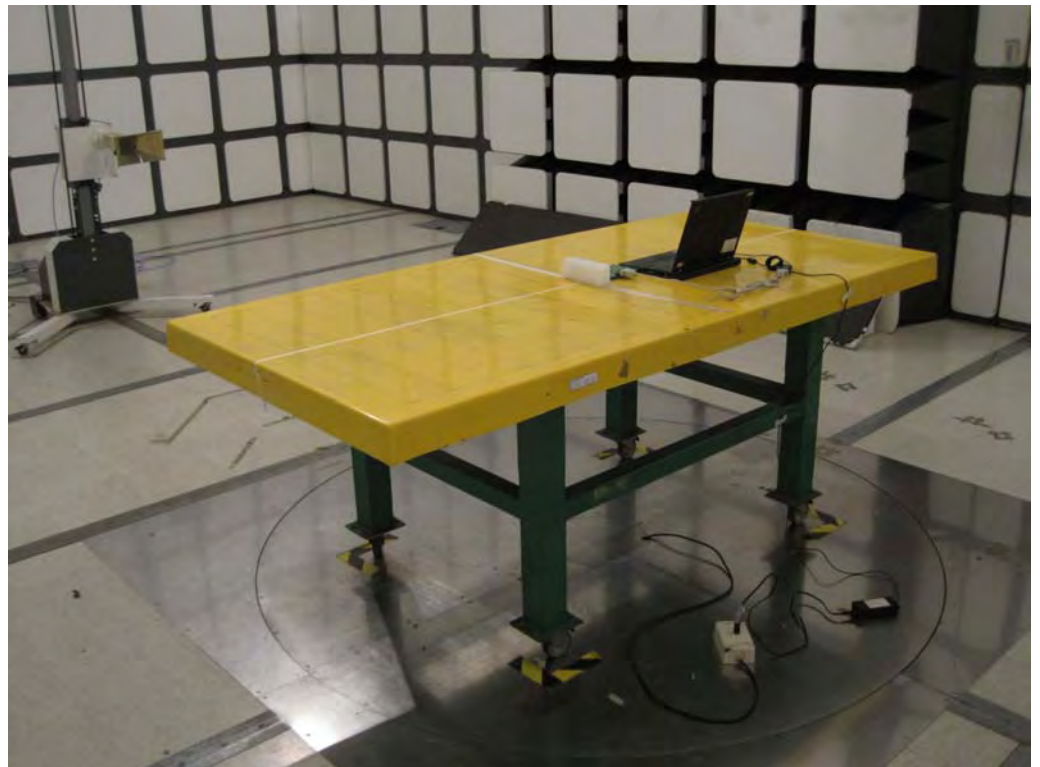

## Appendix B. Maximum Permissible Exposure

# 1. Maximum Permissible Exposure

## 1.1. Applicable Standard

Systems operating under the provisions of this section shall be operated in a manner that ensures that the public is not exposed to radio frequency energy levels in excess limit for maximum permissible exposure. In accordance with 47 CFR FCC Part 2 Subpart J, section 2.1091 this device has been defined as a mobile device whereby a distance of 0.25 m normally can be maintained between the user and the device.

(A) Limits for Occupational / Controlled Exposure

Frequency Range (MHz)	Electric Field Strength (E) (V/m)	Magnetic Field Strength (H) (A/m)	Power Density (S) (mW/ cm <sup>2</sup> )	Averaging Time  E  <sup>2</sup> ,  H  <sup>2</sup> or S (minutes)
0.3-3.0	614	1.63	(100)*	6
3.0-30	1842 / f	4.89 / f	(900 / f)*	6
30-300	61.4	0.163	1.0	6
300-1500			F/300	6
1500-100,000			5	6

(B) Limits for General Population / Uncontrolled Exposure

Frequency Range (MHz)	Electric Field Strength (E) (V/m)	Magnetic Field Strength (H) (A/m)	Power Density (S) (mW/ cm <sup>2</sup> )	Averaging Time  E  <sup>2</sup> ,  H  <sup>2</sup> or S (minutes)
0.3-1.34	614	1.63	(100)*	30
1.34-30	824/f	2.19/f	(180/f)*	30
30-300	27.5	0.073	0.2	30
300-1500			F/1500	30
1500-100,000			1.0	30

Note: f = frequency in MHz ; \*Plane-wave equivalent power density

## 1.2. MPE Calculation Method

$$E \text{ (V/m)} = \frac{\sqrt{30 \times P \times G}}{d} \quad \text{Power Density: } Pd \text{ (W/m}^2\text{)} = \frac{E^2}{377}$$

**E** = Electric field (V/m)

**P** = Average RF output power (W)

**G** = EUT Antenna numeric gain (numeric)

**d** = Separation distance between radiator and human body (m)

The formula can be changed to

$$Pd = \frac{30 \times P \times G}{377 \times d^2}$$

From the EUT RF output power, the minimum mobile separation distance, d=0.2m, as well as the gain of the used antenna, the RF power density can be obtained.

### 1.3. Calculated Result and Limit

For 5GHz UNII Band:

Antenna Type : PIFA Antenna

Max Conducted Power for IEEE 802.11a : 13.38dBm

Directional Antenna Gain (dBi)	Antenna Gain (numeric)	Average Output Power (dBm)	Average Output Power (mW)	Power Density (S) (mW/cm <sup>2</sup> )	Limit of Power Density (S) (mW/cm <sup>2</sup> )	Test Result
4.30	2.6915	13.3800	21.7771	0.011667	1	Complies

Note: Directional Antenna Gain = Test Antenna Gain + 10 log (Antenna quantity)

For 5GHz ISM Band:

Antenna Type : PIFA Antenna

Max Conducted Power for IEEE 802.11a: 13.25dBm

Directional Antenna Gain (dBi)	Antenna Gain (numeric)	Average Output Power (dBm)	Average Output Power (mW)	Power Density (S) (mW/cm <sup>2</sup> )	Limit of Power Density (S) (mW/cm <sup>2</sup> )	Test Result
4.30	2.6915	13.2500	21.1349	0.011323	1	Complies

Note: Directional Antenna Gain = Test Antenna Gain + 10 log (Antenna quantity)

For 2.4GHz Band:

Antenna Type : PIFA Antenna

Max Conducted Power for IEEE 802.11b : 15.82 dBm

Directional Antenna Gain (dBi)	Antenna Gain (numeric)	Average Output Power (dBm)	Average Output Power (mW)	Power Density (S) (mW/cm <sup>2</sup> )	Limit of Power Density (S) (mW/cm <sup>2</sup> )	Test Result
3	1.9953	15.8200	38.1944	0.015169	1	Complies

Note: Directional Antenna Gain = Test Antenna Gain + 10 log (Antenna quantity)

For Bluetooth 1.0 :

Antenna Type : PIFA Antenna

Max Conducted Power for Bluetooth : 9.32 dBm

Antenna Gain (dBi)	Antenna Gain (numeric)	Average Output Power (dBm)	Average Output Power (mW)	Power Density (S) (mW/cm <sup>2</sup> )	Limit of Power Density (S) (mW/cm <sup>2</sup> )	Test Result
3	1.9953	9.3200	8.5507	0.003396	1	Complies

For Bluetooth 2.1+EDR :

Antenna Type : PIFA Antenna

Max Conducted Power for Bluetooth : 9.50 dBm

Antenna Gain (dBi)	Antenna Gain (numeric)	Average Output Power (dBm)	Average Output Power (mW)	Power Density (S) (mW/cm <sup>2</sup> )	Limit of Power Density (S) (mW/cm <sup>2</sup> )	Test Result
3	1.9953	9.5000	8.9125	0.003540	1	Complies

For Bluetooth 4.0 :

Antenna Type : PIFA Antenna

Max Conducted Power for Bluetooth : 7.80 dBm

Antenna Gain (dBi)	Antenna Gain (numeric)	Average Output Power (dBm)	Average Output Power (mW)	Power Density (S) (mW/cm <sup>2</sup> )	Limit of Power Density (S) (mW/cm <sup>2</sup> )	Test Result
3	1.9953	7.8000	6.0256	0.002393	1	Complies

**CONCLUSION:**

Both of the WLAN 5GHz Band and Bluetooth can transmit simultaneously, the formula of calculated the MPE is:

$$CPD1 / LPD1 + CPD2 / LPD2 + \dots \text{etc.} < 1$$

CPD = Calculation power density

LPD = Limit of power density

Therefore, the worst-case situation is  $0.011667 / 1 + 0.003540 / 1 = 0.015207$ , which is less than "1". This confirmed that the device comply with FCC 1.1310 MPE limit.

## Appendix C. Co-location

# 1. Results of Radiated Emissions for Co-located

<b>Temperature</b>	21°C	<b>Humidity</b>	56.4%
<b>Test Engineer</b>	Benson Peng	<b>Configurations</b>	5G + BT

## Horizontal

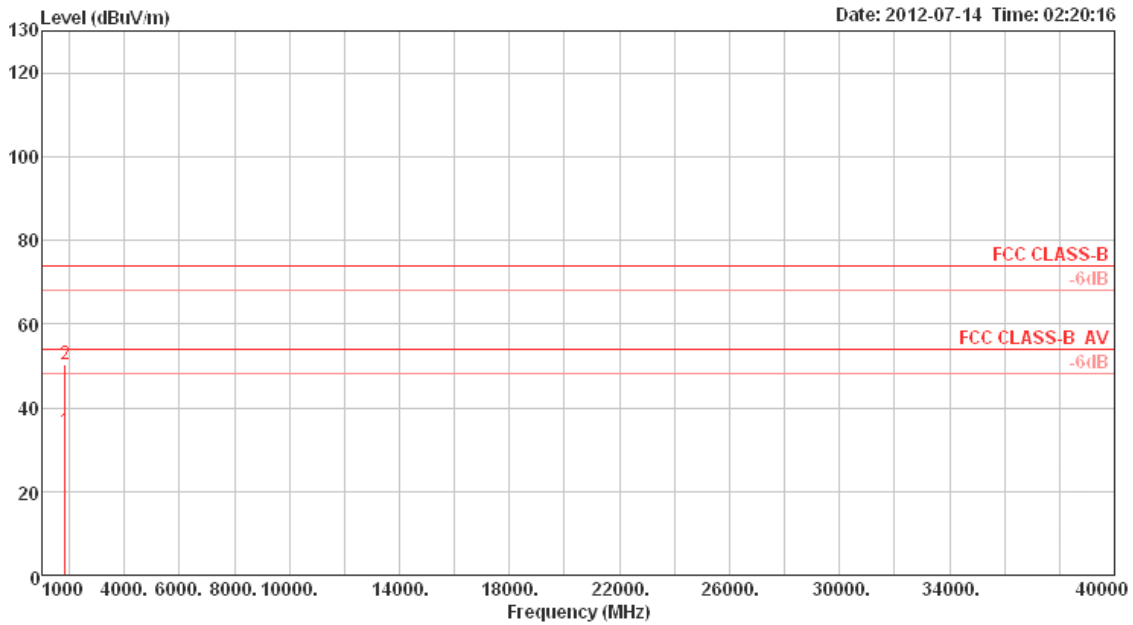

	Freq	Level	Limit Line	Over Limit	Read Level	Cable Loss	Antenna Factor	Preamp Factor	Remark	A/Pos	T/Pos	Pol/Phase
	MHz	dBuV/m	dBuV/m	dB	dBuV	dB	dB/m	dB		cm	deg	
1	1842.20	34.56	54.00	-19.44	38.98	3.85	26.63	34.90	Average	100	351	HORIZONTAL
2	1842.20	50.16	74.00	-23.84	54.58	3.85	26.63	34.90	Peak	100	351	HORIZONTAL

**Vertical**

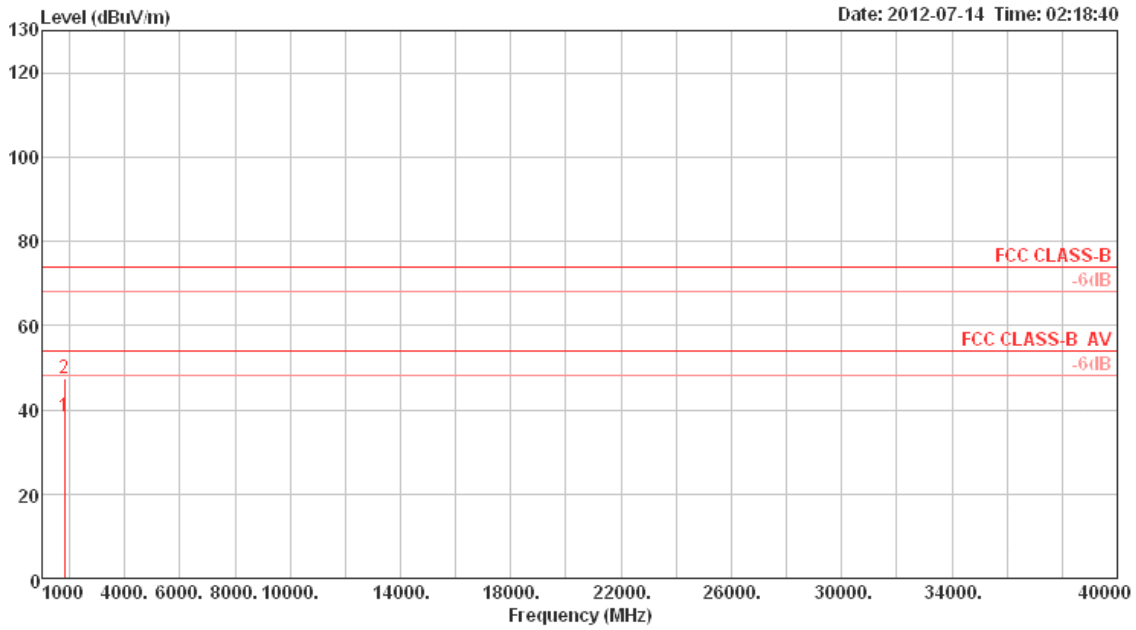

	Freq	Level	Limit Line	Over Limit	Read Level	Cable Loss	Antenna Factor	Preamp Factor	Remark	A/Pos	T/Pos	Pol/Phase
	MHz	dBuV/m	dBuV/m	dB	dBuV	dB	dB/m	dB		cm	deg	
1	1808.20	38.45	54.00	-15.55	43.02	3.80	26.53	34.90	Average	105	228	VERTICAL
2	1808.20	47.60	74.00	-26.40	52.17	3.80	26.53	34.90	Peak	105	228	VERTICAL