

FCC Radio Test Report

FCC ID: PU5-LN300WG3L

Report No. : BTL-FCCP-13-2102T172A
Equipment : Notebook Computer
Model Name : Lenovo 300w Gen 3xxxxxxx (The "x" in model name can be 0 to 9, A to Z, a to z, "-" or blank, for marketing purpose only)
Brand Name : Lenovo
Applicant : Wistron Corporation
Address : 21F, No. 88, Sec. 1, Hsin Tai Wu Rd., Hsichih Dist, New Taipei City 221, Taiwan

Radio Function : WCDMA Band V, LTE Band 5, 26

FCC Rule Part(s) : 47 CFR FCC Part 22 Subpart H
Measurement Procedure(s) : ANSI C63.26-2015
ANSI/TIA-603-E-2016
FCC KDB 971168 D01 Power Meas License Digital Systems v03r01

Date of Receipt : 2021/3/12
Date of Test : 2021/3/12 ~ 2021/3/31
Issued Date : 2021/4/27

The above equipment has been tested and found in compliance with the requirement of the above standards by BTL Inc.

Prepared by



Peter Chen, Engineer

Approved by

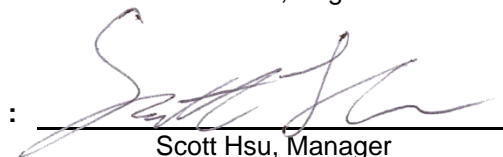

Scott Hsu, Manager



BTL Inc.

No.18, Ln. 171, Sec. 2, Jiuzong Rd., Neihu Dist., Taipei City 114, Taiwan

Tel: +886-2-2657-3299

Fax: +886-2-2657-3331

Web: www.newbtl.com

Declaration

BTL represents to the client that testing is done in accordance with standard procedures as applicable and that test instruments used has been calibrated with standards traceable to international standard(s) and/or national standard(s).

BTL's reports apply only to the specific samples tested under conditions. It is manufacture's responsibility to ensure that additional production units of this model are manufactured with the identical electrical and mechanical components. **BTL** shall have no liability for any declarations, inferences or generalizations drawn by the client or others from **BTL** issued reports.

This report is the confidential property of the client. As a mutual protection to the clients, the public and ourselves, the test report shall not be reproduced, except in full, without our written approval.

BTL's laboratory quality assurance procedures are in compliance with the **ISO/IEC 17025** requirements, and accredited by the conformity assessment authorities listed in this test report.

BTL is not responsible for the sampling stage, so the results only apply to the sample as received.

The information, data and test plan are provided by manufacturer which may affect the validity of results, so it is manufacturer's responsibility to ensure that the apparatus meets the essential requirements of applied standards and in all the possible configurations as representative of its intended use.

Limitation

For the use of the authority's logo is limited unless the Test Standard(s)/Scope(s)/Item(s) mentioned in this test report is (are) included in the conformity assessment authorities acceptance respective.

Please note that the measurement uncertainty is provided for informational purpose only and are not use in determining the Pass/Fail results.

CONTENTS

1	SUMMARY OF TEST RESULTS	5
1.1	TEST FACILITY	6
1.2	MEASUREMENT UNCERTAINTY	6
1.3	TEST ENVIRONMENT CONDITIONS	6
2	GENERAL INFORMATION	7
2.1	DESCRIPTION OF EUT	7
2.2	TEST MODES	7
2.3	BLOCK DIAGRAM SHOWING THE CONFIGURATION OF SYSTEM TESTED	8
2.4	SUPPORT UNITS	9
3	AC POWER LINE CONDUCTED EMISSIONS TEST	10
3.1	LIMIT	10
3.2	TEST PROCEDURE	10
3.3	DEVIATION FROM TEST STANDARD	10
3.4	TEST SETUP	11
3.5	TEST RESULT	11
4	RADIATED SPURIOUS EMISSIONS MEASUREMENT	12
4.1	LIMIT	12
4.2	TEST PROCEDURE	12
4.3	DEVIATION FROM TEST STANDARD	12
4.4	TEST SETUP	13
4.5	EUT OPERATING CONDITIONS	13
4.6	TEST RESULT	13
5	LIST OF MEASURING EQUIPMENTS	14
6	EUT TEST PHOTO	15
7	EUT PHOTOS	15
APPENDIX A	AC POWER LINE CONDUCTED EMISSIONS	16
APPENDIX B	RADIATED SPURIOUS EMISSIONS	21
APPENDIX C	REFERENCE INFORMATION	52

REVISION HISTORY

Report No.	Version	Description	Issued Date
BTL-FCCP-13-2102T172A	R00	Original Report.	2021/4/27

1 SUMMARY OF TEST RESULTS

Test procedures according to the technical standards.

FCC Clause No	Description	Test Result	Judgement	Remark
15.207	AC Power Line Conducted Emissions	APPENDIX A	Pass	-----
2.1053 22.917(a)	Radiated Spurious Emissions	APPENDIX B	Pass	-----

NOTE:

- (1) "N/A" denotes test is not applicable in this Test Report.
- (2) The report format version is TP.1.1.1.
- (3) The WWAN test result refer FCC ID: PU5-LN300WG3D that the system of 2 FCC IDs (WWAN system IDs) are identical HW design of system, the same WWAN module and WWAN + WLAN antennas. The only difference is different FCC ID contains different certified WLAN module.
- (4) After spot check, this revision does not change original radio parameters.

1.1 TEST FACILITY

The test facilities used to collect the test data in this report:

No. 68-1, Ln. 169, Sec. 2, Datong Rd., Xizhi Dist., New Taipei City 221, Taiwan

The test sites and facilities are covered under FCC RN: 674415 and DN: TW0659.

C05
 CB08
 CB11
 CB15
 CB16

1.2 MEASUREMENT UNCERTAINTY

The reported uncertainty of measurement $y \pm U$, where expanded uncertainty U is based on a standard uncertainty multiplied by a coverage factor of $k = 2$, providing a level of confidence of approximately **95 %**. The measurement instrumentation uncertainty considerations contained in CISPR 16-4-2. The BTL measurement uncertainty is less than the CISPR 16-4-2 U_{cispr} requirement.

A. AC power line conducted emissions test:

Test Site	Method	Measurement Frequency Range	U (dB)
C05	CISPR	150 kHz ~ 30MHz	3.44

B. Radiated emissions test :

Test Site	Measurement Frequency Range	U,(dB)
CB15	0.03 GHz ~ 0.2 GHz	4.17
	0.2 GHz ~ 1 GHz	4.72
	1 GHz ~ 6 GHz	5.21
	6 GHz ~ 18 GHz	5.51
	18 GHz ~ 26 GHz	3.69
	26 GHz ~ 40 GHz	4.23

NOTE:

Unless specifically mentioned, the uncertainty of measurement has not been taken into account to declare the compliance or non-compliance to the specification.

1.3 TEST ENVIRONMENT CONDITIONS

Test Item	Environment Condition	Test Voltage	Tested by
AC Power Line Conducted Emissions	20 °C, 72 %	AC 120V	Vincent Lee
Radiated Spurious Emissions	Refer to data	AC 120V	Jay Kao

2 GENERAL INFORMATION

2.1 DESCRIPTION OF EUT

Equipment	Notebook Computer		
Model Name	Lenovo 300w Gen 3xxxxxxx (The "x" in model name can be 0 to 9, A to Z, a to z, "-" or blank, for marketing purpose only)		
Brand Name	Lenovo		
Model Difference	Different model distribute to different area.		
Power Source	DC voltage supplied from External Power Supply. (Lenovo/ADLX45YLC3D)		
Power Rating	I/P: 100-240V~1.3A 50-60Hz O/P: 20.0V---2.25A 45.0W / 15.0V---3.0A / 9.0V---2.0A / 5.0V---2.0A 10.0W		
Products Covered	1 * Adapter: Lenovo/ADLX45YLC3D		
WIFI+BT Module	Realtek / RTL8822CE		
WWAN Module	Fibocom / L850-GL		
Operation Frequency	Band	UL Frequency (MHz)	DL Frequency (MHz)
	WCDMA V	824 ~ 849	869 ~ 894
	LTE 5	824 ~ 849	869 ~ 894
	LTE 26	824 ~ 849	869 ~ 894
Test Model	Lenovo 300w Gen 3		
Sample Status	Engineering Sample		
EUT Modification(s)	N/A		

NOTE:

(1) For a more detailed features description, please refer to the manufacturer's specifications or the user's manual.

(2) Table for Filed Antenna:

Antenna	Manufacture	Parts Number	Type	Connector	Gain (dBi)	Note
Main	INPAQ Corporation	025.901TX.0001	PIFA	I-PEX	-5.74	WCDMA Band V
					-5.67	LTE Band 5
						LTE Band 26
Aux	INPAQ Corporation	025.901TY.0001	PIFA	I-PEX	-	RX only

2.2 TEST MODES

Test Items	Band	Test Mode	Note
AC Power Line Conducted Emissions	-	Normal/Idle	-
Radiated Spurious Emissions	WCDMA Band V	TX Mode (CH 4357/4407/4458)	-
	LTE Band 5	TX Mode (CH 20450/20525/20600)	-
	LTE Band 26	TX Mode (CH 26865/26915/26965)	-

NOTE:

(1) The Radiated emissions test was verified based on the worst conducted power and Bandwidth test results reported in the original report.

(2) All X, Y and Z axes are evaluated, but only the worst case (X axis) is recorded.

2.3 BLOCK DIAGRAM SHOWING THE CONFIGURATION OF SYSTEM TESTED

Equipment letters and Cable numbers refer to item numbers described in the tables of clause 2.4.

AC Power Line Conducted Emissions Test

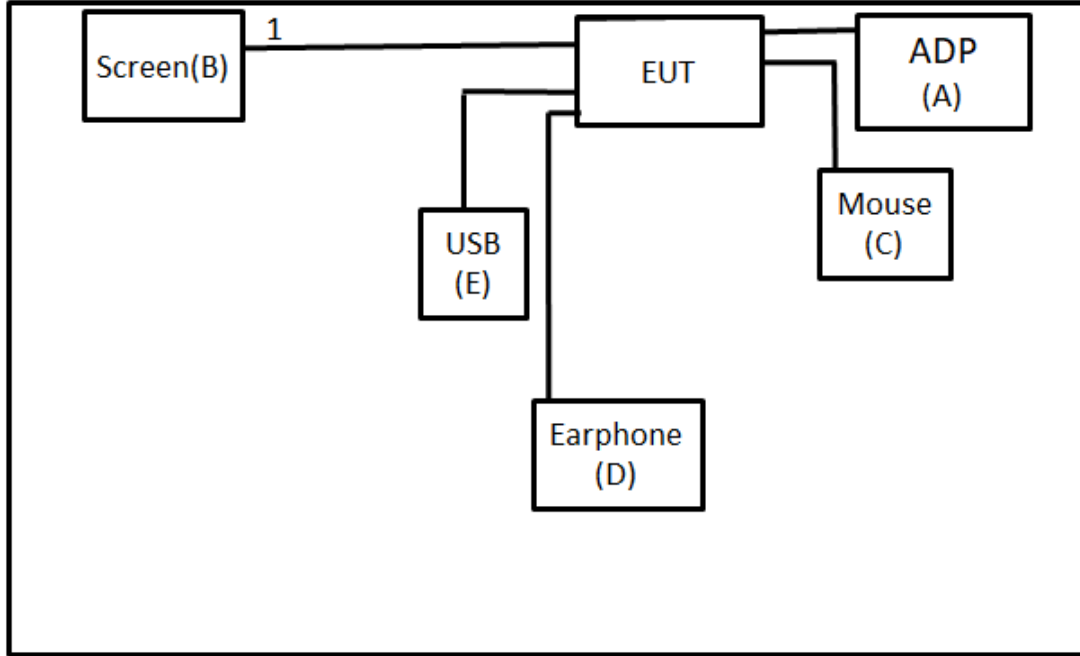

Radiated Emissions Test

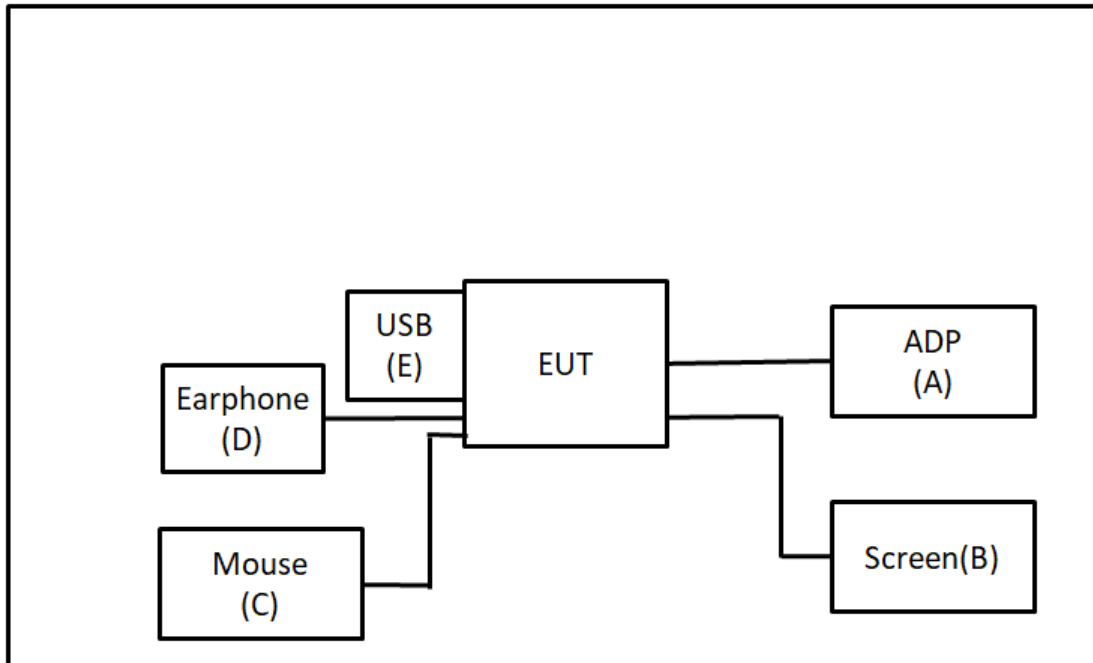

2.4 SUPPORT UNITS

Item	Equipment	Brand	Model No.	Series No.	Remarks
A	ADP	Lenovo	ADLX45YLC3D	N/A	Supplied by test requester.
B	Screen	ASUS	MX27U	N/A	Furnished by test lab.
C	Mouse	ACER	MP-368	N/A	Furnished by test lab.
D	Earphone	Sony	MDR-E9LP	N/A	Furnished by test lab.
E	USB	Kingston	C7052-322.AOOL F	N/A	Furnished by test lab.

Item	Shielded	Ferrite Core	Length	Cable Type	Remarks
1	N/A	N/A	1.8m	HDMI Cable	Furnished by test lab.

3 AC POWER LINE CONDUCTED EMISSIONS TEST

3.1 LIMIT

Frequency (MHz)	Limit (dB μ V)	
	Quasi-peak	Average
0.15 - 0.5	66 - 56 *	56 - 46 *
0.50 - 5.0	56	46
5.0 - 30.0	60	50

NOTE:

- (1) The tighter limit applies at the band edges.
- (2) The limit of " * " marked band means the limitation decreases linearly with the logarithm of the frequency in the range.
- (3) The test result calculated as following:
 Measurement Value = Reading Level + Correct Factor
 Correct Factor = Insertion Loss + Cable Loss + Attenuator Factor (if use)
 Margin Level = Measurement Value – Limit Value
 Calculation example:

Reading Level		Correct Factor		Measurement Value
38.22	+	3.45	=	41.67

Measurement Value		Limit Value		Margin Level
41.67	-	60	=	-18.33

The following table is the setting of the receiver.

Receiver Parameter	Setting
Attenuation	10 dB
Start Frequency	0.15 MHz
Stop Frequency	30 MHz
IF Bandwidth	9 KHz

3.2 TEST PROCEDURE

- a. The EUT was placed 0.8 m above the horizontal ground plane with the EUT being connected to the power mains through a line impedance stabilization network (LISN).
 All other support equipment were powered from an additional LISN(s).
 The LISN provides 50 Ohm/50uH of impedance for the measuring instrument.
- b. Interconnecting cables that hang closer than 40 cm to the ground plane shall be folded back and forth in the center forming a bundle to keep the cable above 40 cm.
- c. Excess I/O cables that are not connected to a peripheral shall be bundled in the center.
 The end of the cable will be terminated, using the correct terminating impedance.
 The overall length shall not exceed 1 m.
- d. The LISN is spaced at least 80 cm from the nearest part of the EUT chassis.
- e. For the actual test configuration, please refer to the related Item - EUT TEST PHOTO.

NOTE:

- (1) In the results, each reading is marked as Peak, QP or AVG per the detector used.
 BW=9 kHz (6 dB Bandwidth)
- (2) All readings are Peak unless otherwise stated QP or AVG in column of Note. Both the QP and the AVG readings must be less than the limit for compliance.

3.3 DEVIATION FROM TEST STANDARD

No deviation.

3.4 TEST SETUP

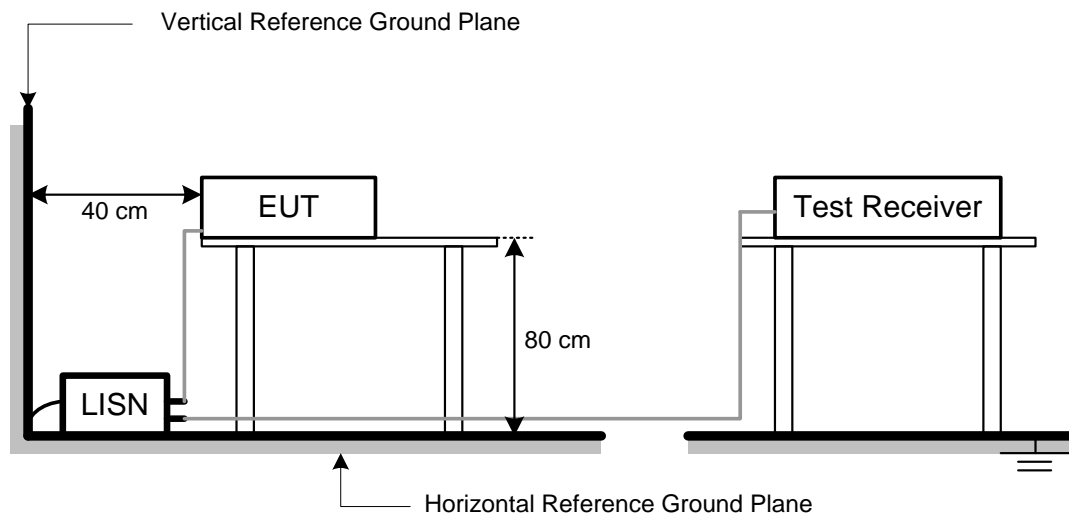

3.5 TEST RESULT

Please refer to the APPENDIX A.

4 RADIATED SPURIOUS EMISSIONS MEASUREMENT

4.1 LIMIT

The power of any emission outside of the authorized operating frequency ranges must be attenuated below the transmitting power (P) by a factor of at least $43 + 10 \log(P)$ dB. The emission limit equal to -13dBm.

NOTE:

(1) The test result calculated as following:

Measurement Value = Reading Level + Correct Factor

Correct Factor = Antenna Factor + Cable Loss - Amplifier Gain(if use)

Margin Level = Measurement Value - Limit Value

Calculation example:

Reading Level		Correct Factor		Measurement Value
-50.43	+	-2.11	=	-52.54

Measurement Value		Limit Value		Margin Level
-52.54	-	-13	=	-39.54

4.2 TEST PROCEDURE

The testing follows FCC KDB 971168 v03r01 Section 6.2.

- a. Substitution method is used for E.I.R.P measurement. In the semi-anechoic chamber, EUT placed on the 0.8m height of Turn Table, rotated the table around 360 degrees to search the maximum radiation power and receiver antenna shall be rotated vertical and horizontal polarization and moved height from 1m to 4m to find the maximum polar radiated power. The "Read Value" is the spectrum reading the maximum power value.
- b. The substitution horn antenna is substituted for EUT at the same position and signals generator export the CW signal to the substitution antenna via a TX cable. Rotated the Turn Table and moved receiving antenna to find the maximum radiation power. Adjust output power level of S.G to get a Value of spectrum reading equal to "Read Value " of step a. Record the power level of S.G
- c. EIRP = Output power level of S.G – TX cable loss + Antenna gain of substitution horn.
- d. ERP can be calculated form EIRP by subtracting the gain of dipole, ERP = EIPR - 2.15dBi..
- e. The resolution bandwidth and video bandwidth of test receiver/spectrum analyzer is 1MHz/3MHz.

4.3 DEVIATION FROM TEST STANDARD

No deviation.

4.4 TEST SETUP

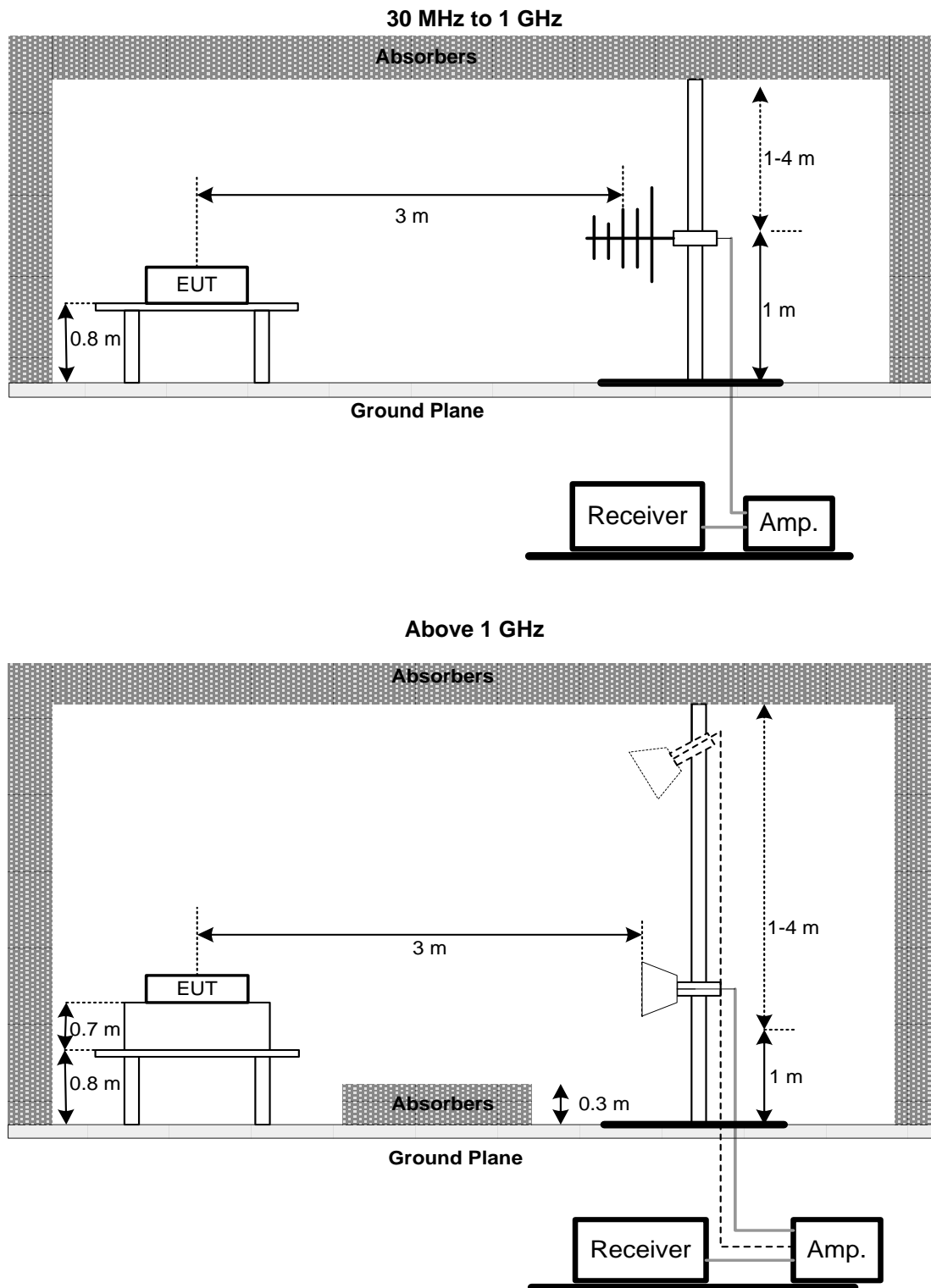

4.5 EUT OPERATING CONDITIONS

The EUT was programmed to be in continuously transmitting mode.

4.6 TEST RESULT

Please refer to the APPENDIX B.

5 LIST OF MEASURING EQUIPMENTS

AC Power Line Conducted Emissions						
Item	Kind of Equipment	Manufacturer	Type No.	Serial No.	Calibrated Date	Calibrated Until
1	TWO-LINE V-NETWORK	R&S	ENV216	101050	2020/6/11	2021/6/10
2	Test Cable	EMCI	EMC400-BM-BM-5000	170501	2020/6/8	2021/6/7
3	EMI Test Receiver	R&S	ESCI	100080	2020/6/15	2021/6/14
4	Measurement Software	EZ	EZ EMC (Version NB-03A1-01)	N/A	N/A	N/A

Radiated Emissions						
Item	Kind of Equipment	Manufacturer	Type No.	Serial No.	Calibrated Date	Calibrated Until
1	Preamplifier	EMCI	EMC02325B	980217	2020/4/10	2021/4/9
2	Preamplifier	EMCI	EMC012645B	980267	2020/4/10	2021/4/9
3	Test Cable	EMCI	EMC-SM-SM-1000	180809	2020/4/10	2021/4/9
4	Test Cable	EMCI	EMC104-SM-SM-3000	151205	2020/4/10	2021/4/9
5	Test Cable	EMCI	EMC-SM-SM-7000	180408	2020/4/10	2021/4/9
6	MXE EMI Receiver	Agilent	N9038A	MY554200087	2020/6/10	2021/6/9
7	Signal Analyzer	Agilent	N9010A	MY56480554	2020/8/25	2021/8/24
8	Horn Ant	SCHWARZBECK	BBHA 9120D	9120D-1342	2020/6/12	2021/6/11
9	Horn Ant	Schwarzbeck	BBHA 9170	BBHA 9170340	2020/7/9	2021/7/8
10	Trilog-Broadband Antenna	Schwarzbeck	VULB 9168	VULB 9168-352	2020/7/24	2021/7/23
11	5dB Attenuator	EMCI	EMCI-N-6-05	AT-N0625	2020/7/24	2021/7/23
12	Measurement Software	EZ	EZ EMC (Version NB-03A1-01)	N/A	N/A	N/A
13	8960 Series 10 Wireless Com Test Set	Agilent	E5515C	GB47390193	2020/6/4	2021/6/3
14	Radio Communication Analyzer (LTE)	Anritsu	MT8820C	6201525878	2020/6/3	2021/6/2
15	Radio Communication Analyzer	Anritsu	MT8821C	6262044728	2020/12/15	2021/12/14

Remark: "N/A" denotes no model name, no serial no. or no calibration specified.
All calibration period of equipment list is one year.

6 EUT TEST PHOTO

Please refer to document Appendix No.: TP-2102T172A-2 (APPENDIX-TEST PHOTOS).

7 EUT PHOTOS

Please refer to document Appendix No.: EP-2102T172A-1 (APPENDIX-EUT PHOTOS).

APPENDIX A AC POWER LINE CONDUCTED EMISSIONS

Test Mode	Normal	Tested Date	2021/3/23
Test Frequency	-	Phase	Line

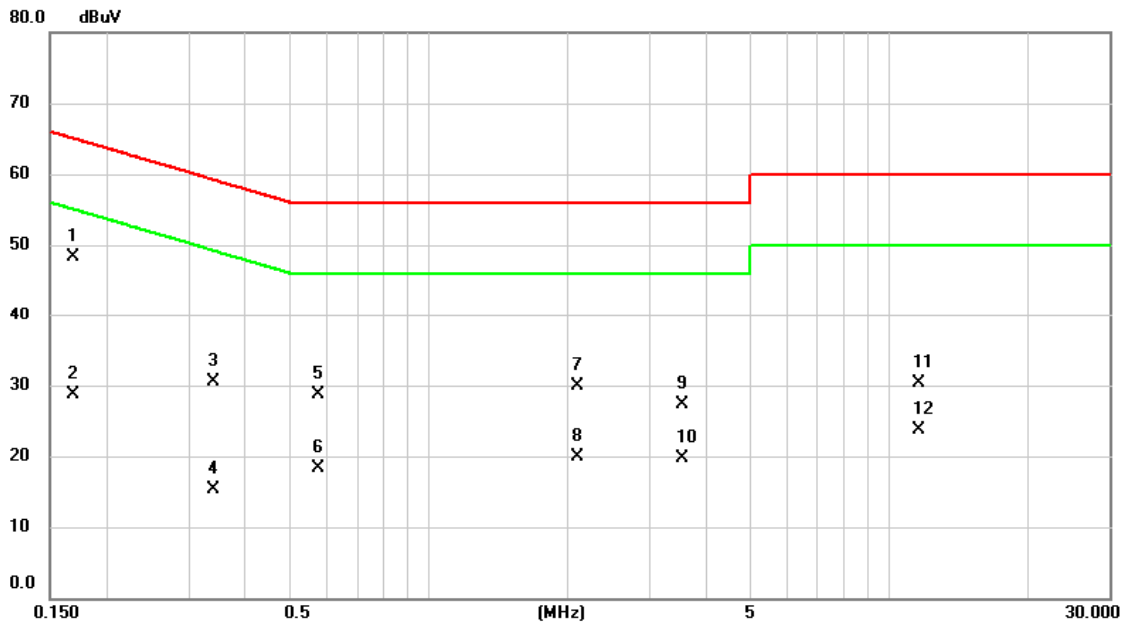

No.	Mk.	Freq.	Reading Level	Correct Factor	Measurement	Limit	Over	Detector	Comment
		MHz	dBuV	dB	dBuV	dBuV	dB		
1	*	0.1685	38.71	9.68	48.39	65.03	-16.64	QP	
2		0.1685	19.08	9.68	28.76	55.03	-26.27	AVG	
3		0.3412	20.75	9.68	30.43	59.17	-28.74	QP	
4		0.3412	5.54	9.68	15.22	49.17	-33.95	AVG	
5		0.5752	19.02	9.68	28.70	56.00	-27.30	QP	
6		0.5752	8.59	9.68	18.27	46.00	-27.73	AVG	
7		2.0963	20.07	9.74	29.81	56.00	-26.19	QP	
8		2.0963	10.25	9.74	19.99	46.00	-26.01	AVG	
9		3.5498	17.43	9.78	27.21	56.00	-28.79	QP	
10		3.5498	9.88	9.78	19.66	46.00	-26.34	AVG	
11		11.5935	20.34	9.93	30.27	60.00	-29.73	QP	
12		11.5935	13.79	9.93	23.72	50.00	-26.28	AVG	

REMARKS:

- (1) Measurement Value = Reading Level + Correct Factor.
- (2) Margin Level = Measurement Value - Limit Value.

Test Mode	Normal	Tested Date	2021/3/23
Test Frequency	-	Phase	Neutral

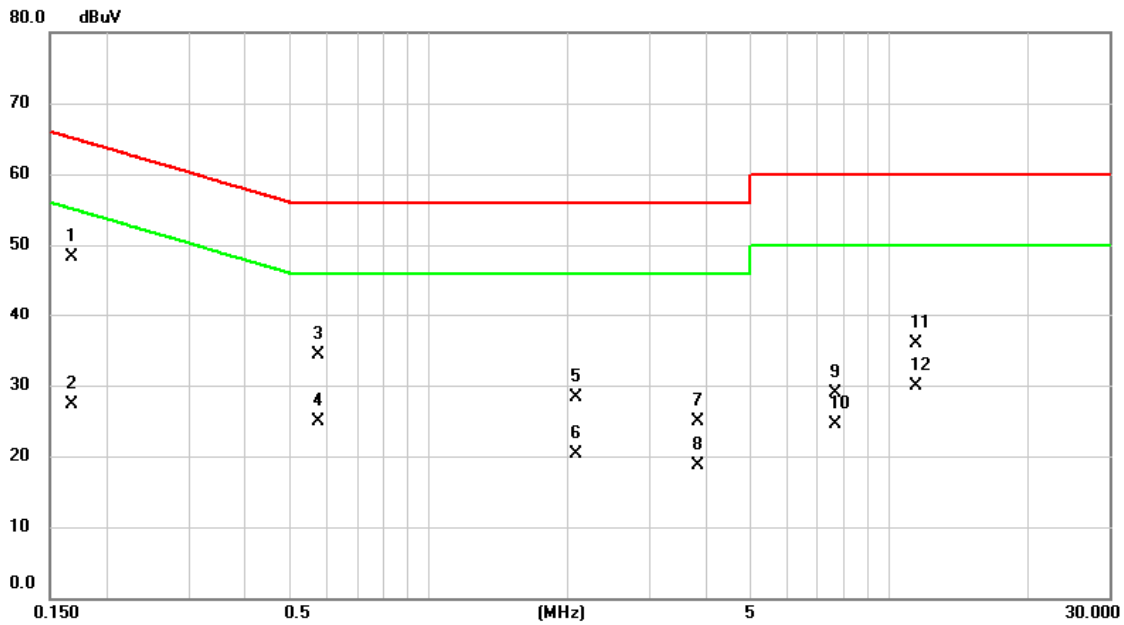

No.	Mk.	Freq. MHz	Reading Level dBuV	Correct Factor dB	Measure- ment dBuV	Limit dBuV	Over dB	Detector	Comment
1	*	0.1668	38.72	9.68	48.40	65.12	-16.72	QP	
2		0.1668	17.60	9.68	27.28	55.12	-27.84	AVG	
3		0.5752	24.68	9.68	34.36	56.00	-21.64	QP	
4		0.5752	15.30	9.68	24.98	46.00	-21.02	AVG	
5		2.0805	18.64	9.74	28.38	56.00	-27.62	QP	
6		2.0805	10.53	9.74	20.27	46.00	-25.73	AVG	
7		3.8288	15.11	9.79	24.90	56.00	-31.10	QP	
8		3.8288	8.95	9.79	18.74	46.00	-27.26	AVG	
9		7.6718	18.96	9.88	28.84	60.00	-31.16	QP	
10		7.6718	14.57	9.88	24.45	50.00	-25.55	AVG	
11		11.4720	25.95	9.93	35.88	60.00	-24.12	QP	
12		11.4720	19.96	9.93	29.89	50.00	-20.11	AVG	

REMARKS:

- (1) Measurement Value = Reading Level + Correct Factor.
- (2) Margin Level = Measurement Value - Limit Value.

Test Mode	Idle	Tested Date	2021/3/23
Test Frequency	-	Phase	Line

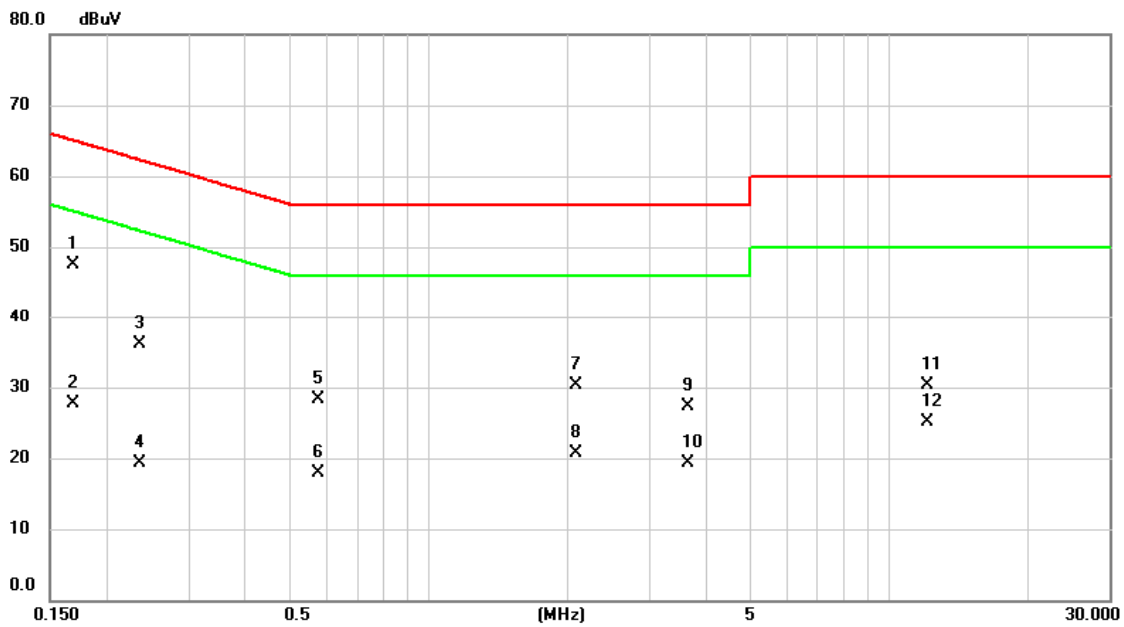

No.	Mk.	Freq.	Reading Level	Correct Factor	Measurement	Limit	Over		
		MHz	dBuV	dB	dBuV	dBuV	dB	Detector	Comment
1	*	0.1680	37.78	9.68	47.46	65.06	-17.60	QP	
2		0.1680	18.12	9.68	27.80	55.06	-27.26	AVG	
3		0.2355	26.49	9.68	36.17	62.25	-26.08	QP	
4		0.2355	9.67	9.68	19.35	52.25	-32.90	AVG	
5		0.5775	18.65	9.68	28.33	56.00	-27.67	QP	
6		0.5775	8.16	9.68	17.84	46.00	-28.16	AVG	
7		2.0873	20.57	9.74	30.31	56.00	-25.69	QP	
8		2.0873	10.94	9.74	20.68	46.00	-25.32	AVG	
9		3.6420	17.45	9.79	27.24	56.00	-28.76	QP	
10		3.6420	9.50	9.79	19.29	46.00	-26.71	AVG	
11		12.1403	20.32	9.93	30.25	60.00	-29.75	QP	
12		12.1403	15.14	9.93	25.07	50.00	-24.93	AVG	

REMARKS:

- (1) Measurement Value = Reading Level + Correct Factor.
- (2) Margin Level = Measurement Value - Limit Value.

Test Mode	Idle	Tested Date	2021/3/23
Test Frequency	-	Phase	Neutral

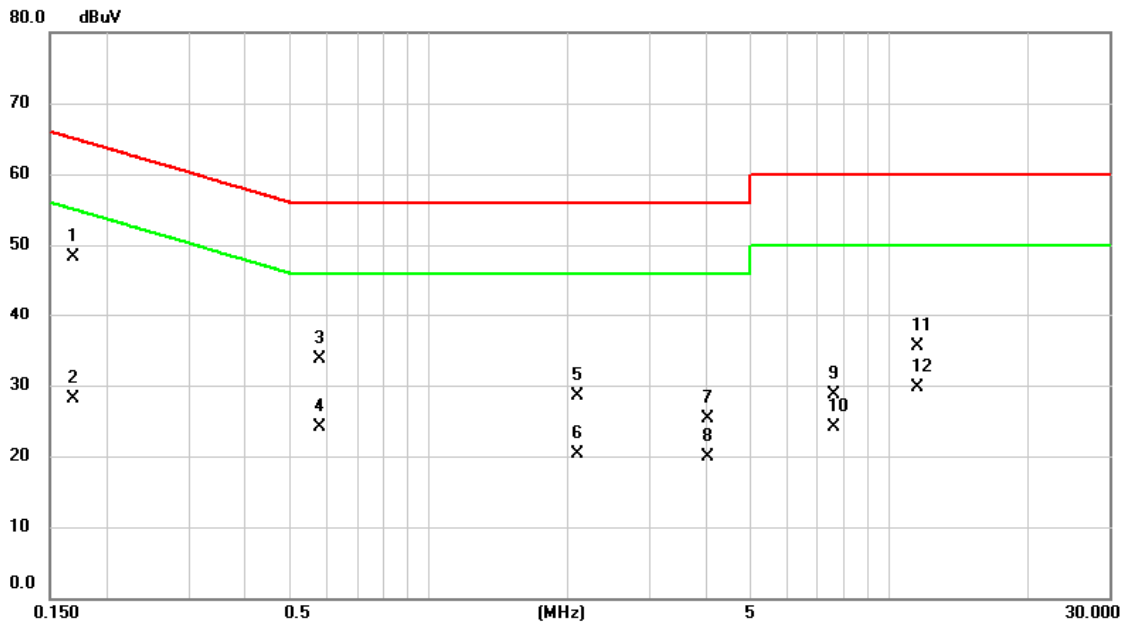

No.	Mk.	Freq. MHz	Reading Level dBuV	Correct Factor dB	Measure- ment dBuV	Limit dBuV	Over dB	Detector	Comment
1	*	0.1685	38.68	9.68	48.36	65.03	-16.67	QP	
2		0.1685	18.51	9.68	28.19	55.03	-26.84	AVG	
3		0.5797	24.08	9.68	33.76	56.00	-22.24	QP	
4		0.5797	14.48	9.68	24.16	46.00	-21.84	AVG	
5		2.1008	18.72	9.74	28.46	56.00	-27.54	QP	
6		2.1008	10.50	9.74	20.24	46.00	-25.76	AVG	
7		4.0313	15.45	9.80	25.25	56.00	-30.75	QP	
8		4.0313	10.04	9.80	19.84	46.00	-26.16	AVG	
9		7.6155	18.77	9.88	28.65	60.00	-31.35	QP	
10		7.6155	14.26	9.88	24.14	50.00	-25.86	AVG	
11		11.5260	25.62	9.93	35.55	60.00	-24.45	QP	
12		11.5260	19.82	9.93	29.75	50.00	-20.25	AVG	

REMARKS:

- (1) Measurement Value = Reading Level + Correct Factor.
- (2) Margin Level = Measurement Value - Limit Value.

APPENDIX B RADIATED SPURIOUS EMISSIONS

Test Mode	WCDMA Band V	Test Date	2021/3/25
Test Channel	CH4407	Polarization	Vertical
Temp	21°C	Hum.	68%

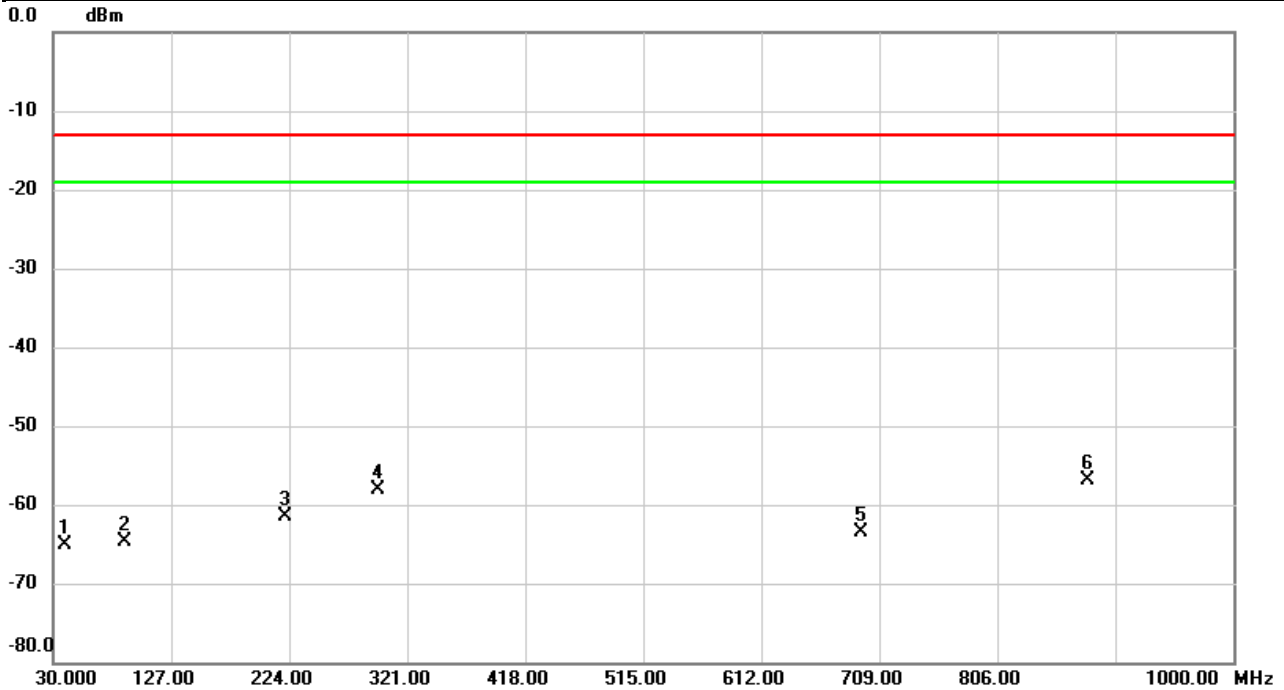

No.	Mk.	Freq. MHz	Reading Level dBm	Correct Factor dB	Measure- ment dBm	Limit dBm	Over dB	Detector	Comment
1		39.7000	-63.75	-1.35	-65.10	-13.00	-52.10	peak	
2		89.1700	-63.07	-1.62	-64.69	-13.00	-51.69	peak	
3		221.0900	-65.02	3.48	-61.54	-13.00	-48.54	peak	
4		296.7500	-65.77	7.62	-58.15	-13.00	-45.15	peak	
5		694.4500	-76.21	12.66	-63.55	-13.00	-50.55	peak	
6	*	880.6900	-67.33	10.42	-56.91	-13.00	-43.91	peak	

REMARKS:

- (1) Measurement Value = Reading Level + Correct Factor.
- (2) Margin Level = Measurement Value - Limit Value.

Test Mode	WCDMA Band V	Test Date	2021/3/25
Test Channel	CH4407	Polarization	Horizontal
Temp	21°C	Hum.	68%

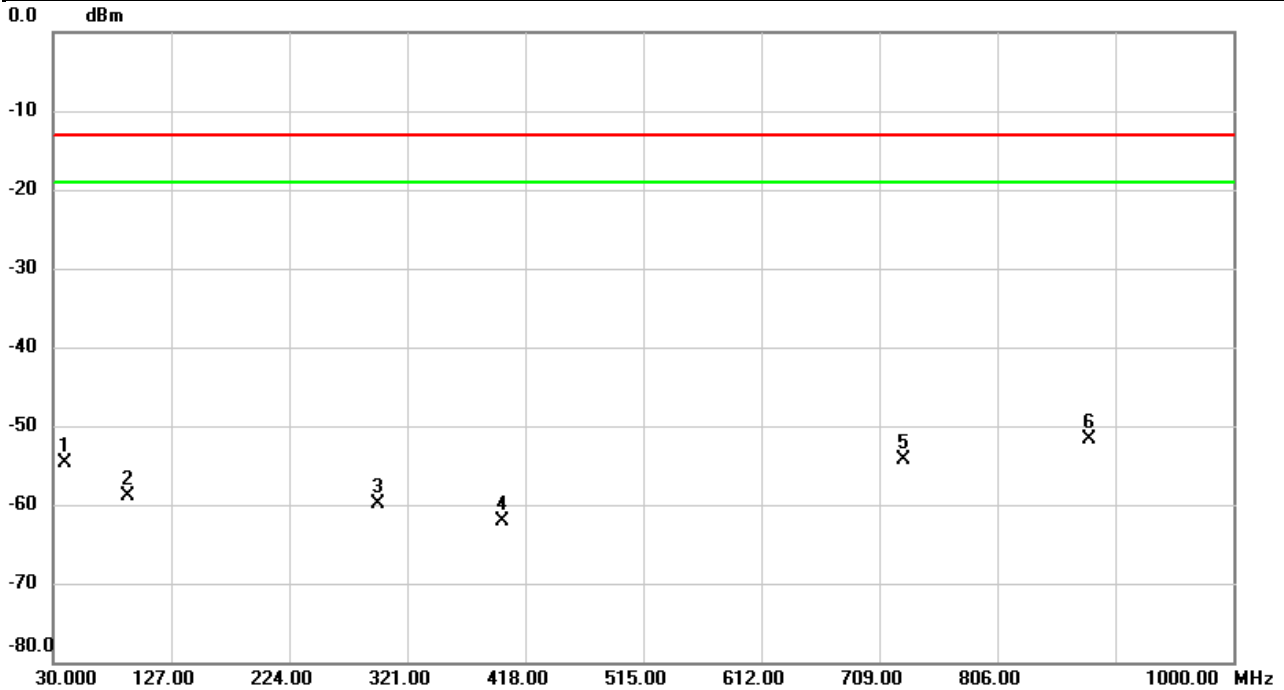

No.	Mk.	Freq. MHz	Reading Level dBm	Correct Factor dB	Measure- ment dBm	Limit dBm	Over dB	Detector	Comment
1		39.7000	-71.61	16.97	-54.64	-13.00	-41.64	peak	
2		91.1100	-62.61	3.63	-58.98	-13.00	-45.98	peak	
3		296.7500	-60.65	0.76	-59.89	-13.00	-46.89	peak	
4		399.5700	-68.28	6.16	-62.12	-13.00	-49.12	peak	
5		729.3700	-65.76	11.37	-54.39	-13.00	-41.39	peak	
6	*	881.6600	-67.64	15.98	-51.66	-13.00	-38.66	peak	

REMARKS:

- (1) Measurement Value = Reading Level + Correct Factor.
- (2) Margin Level = Measurement Value - Limit Value.

Test Mode	WCDMA Band V	Test Date	2021/3/25
Test Channel	CH4357	Polarization	Vertical
Temp	21°C	Hum.	68%

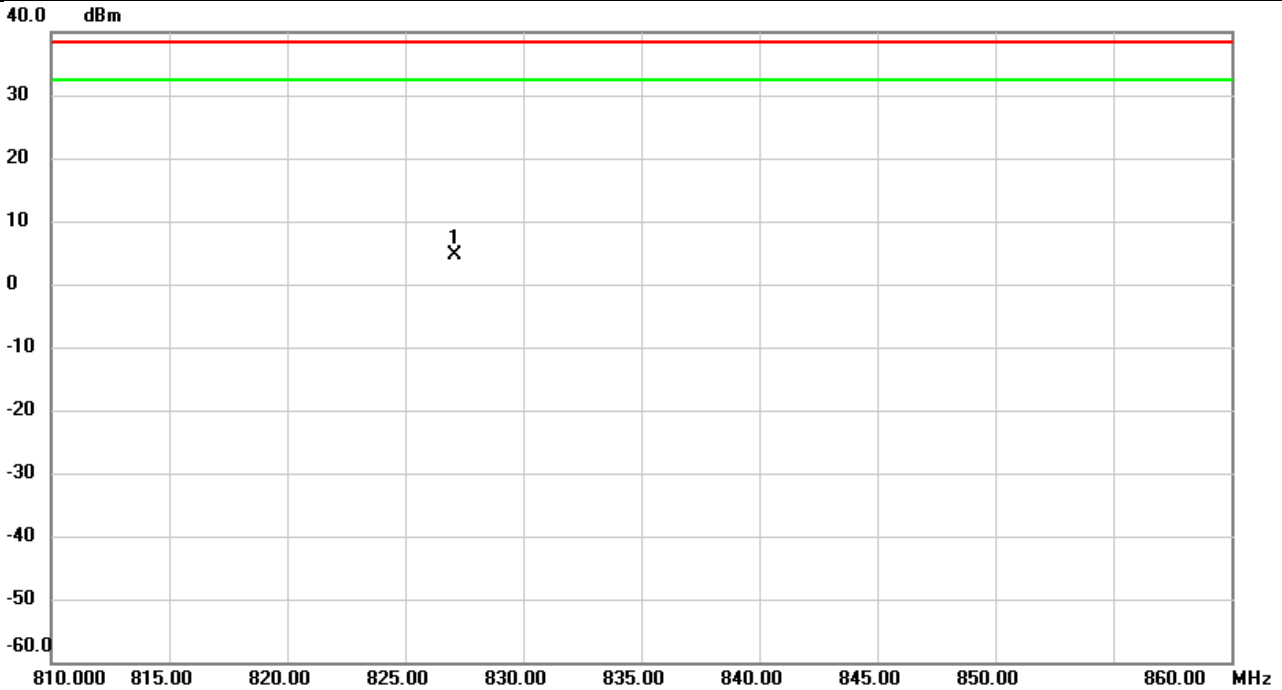

No.	Mk.	Freq.	Reading Level	Correct Factor	Measurement	Limit	Over	Detector	Comment
		MHz	dBm	dB	dBm	dBm	dB		
1	*	827.0750	-29.66	34.26	4.60	38.45	-33.85	peak	

REMARKS:

- (1) Measurement Value = Reading Level + Correct Factor.
- (2) Margin Level = Measurement Value - Limit Value.

Test Mode	WCDMA Band V	Test Date	2021/3/25
Test Channel	CH4357	Polarization	Horizontal
Temp	21°C	Hum.	68%

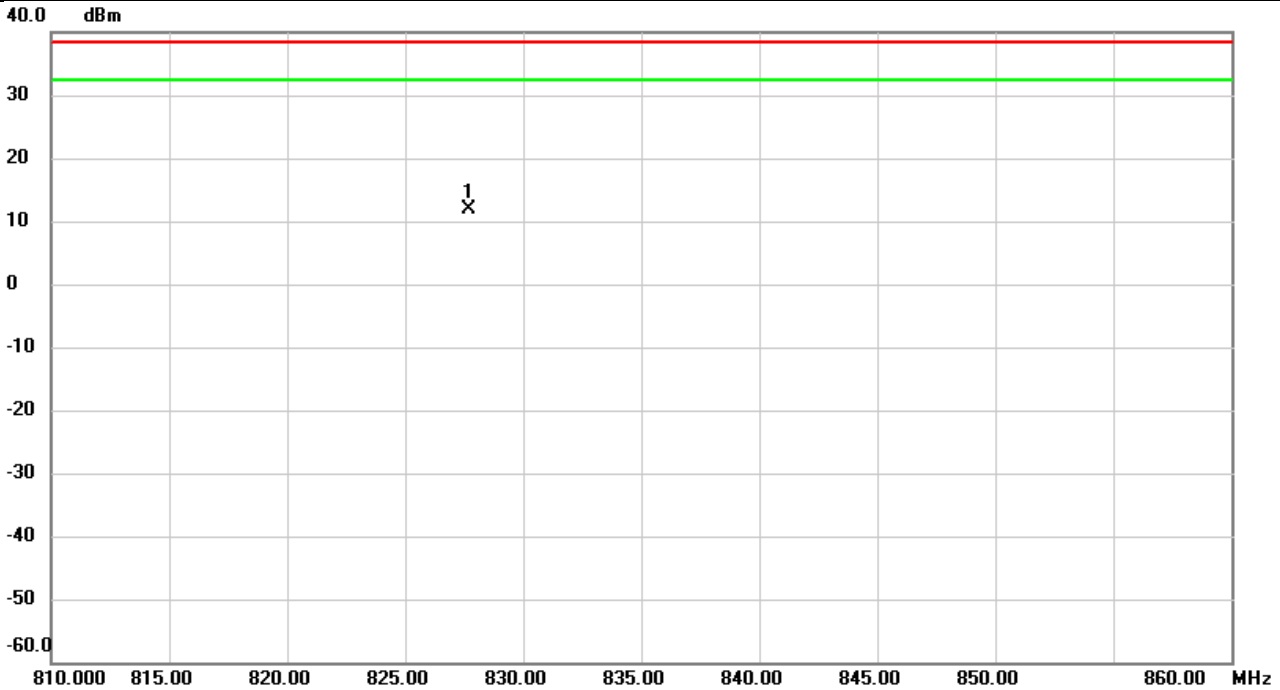

No.	Mk.	Freq.	Reading Level	Correct Factor	Measurement	Limit	Over	Detector	Comment
		MHz	dBm	dB	dBm	dBm	dB		
1	*	827.6800	-21.77	33.54	11.77	38.45	-26.68	peak	

REMARKS:

- (1) Measurement Value = Reading Level + Correct Factor.
- (2) Margin Level = Measurement Value - Limit Value.

Test Mode	WCDMA Band V	Test Date	2021/3/25
Test Channel	CH4407	Polarization	Vertical
Temp	21°C	Hum.	68%

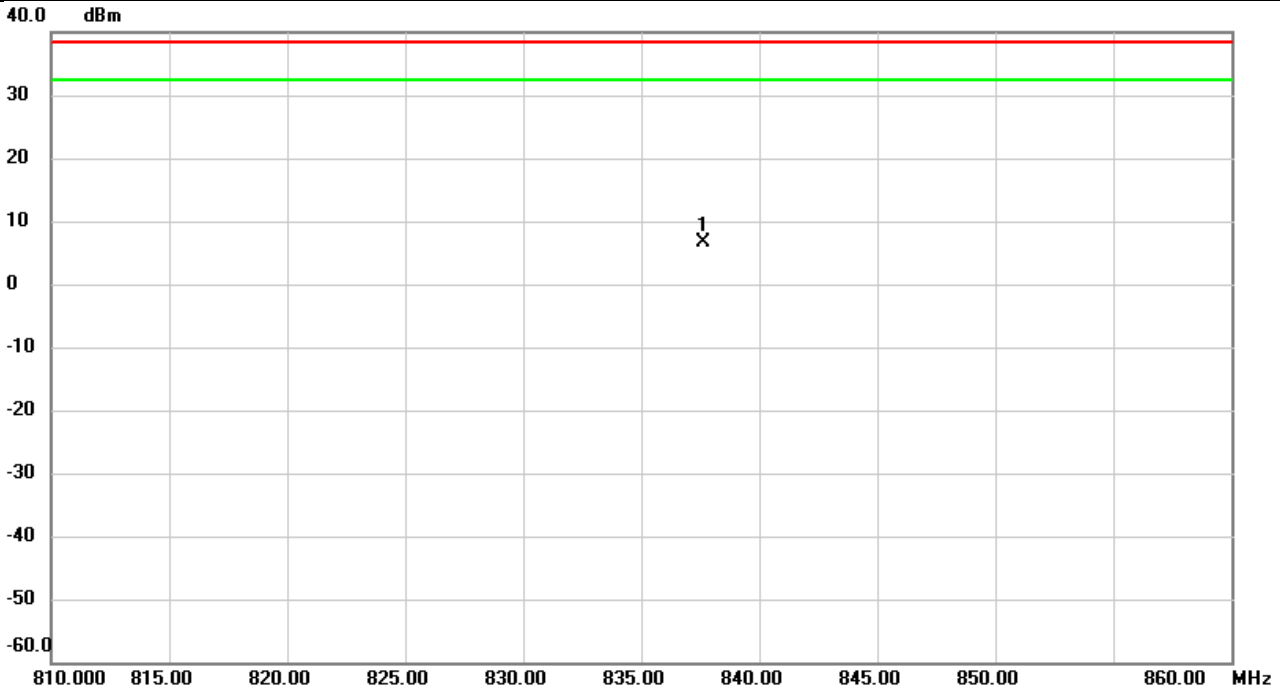

No.	Mk.	Freq.	Reading Level	Correct Factor	Measurement	Limit	Over	Detector	Comment
		MHz	dBm	dB	dBm	dBm	dB		
1	*	837.6367	-27.55	34.23	6.68	38.45	-31.77	peak	

REMARKS:

- (1) Measurement Value = Reading Level + Correct Factor.
- (2) Margin Level = Measurement Value - Limit Value.

Test Mode	WCDMA Band V	Test Date	2021/3/25
Test Channel	CH4407	Polarization	Horizontal
Temp	21°C	Hum.	68%

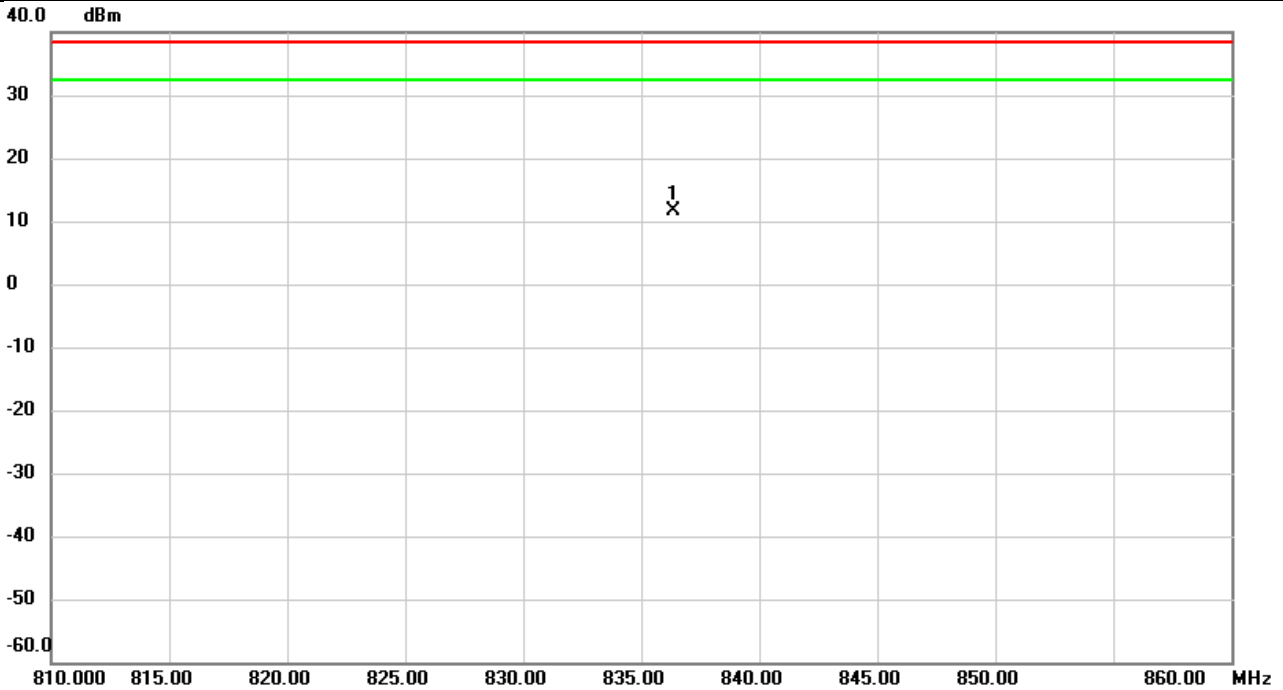

No.	Mk.	Freq.	Reading Level	Correct Factor	Measurement	Limit	Over	Detector	Comment
		MHz	dBm	dB	dBm	dBm	dB		
1	*	836.3767	-21.79	33.52	11.73	38.45	-26.72	peak	

REMARKS:

- (1) Measurement Value = Reading Level + Correct Factor.
- (2) Margin Level = Measurement Value - Limit Value.

Test Mode	WCDMA Band V	Test Date	2021/3/25
Test Channel	CH4458	Polarization	Vertical
Temp	21°C	Hum.	68%

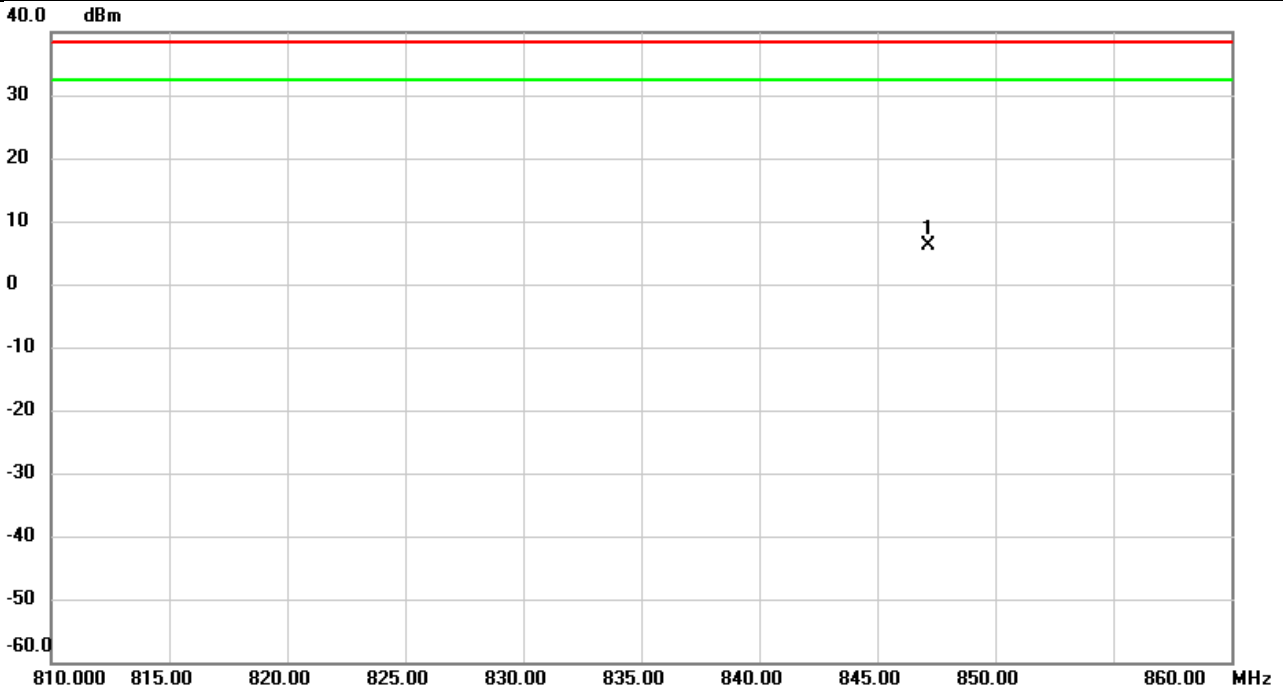

No.	Mk.	Freq.	Reading Level	Correct Factor	Measurement	Limit	Over	Detector	Comment
		MHz	dBm	dB	dBm	dBm	dB		
1	*	847.1817	-28.07	34.20	6.13	38.45	-32.32	peak	

REMARKS:

- (1) Measurement Value = Reading Level + Correct Factor.
- (2) Margin Level = Measurement Value - Limit Value.

Test Mode	WCDMA Band V	Test Date	2021/3/25
Test Channel	CH4458	Polarization	Horizontal
Temp	21°C	Hum.	68%

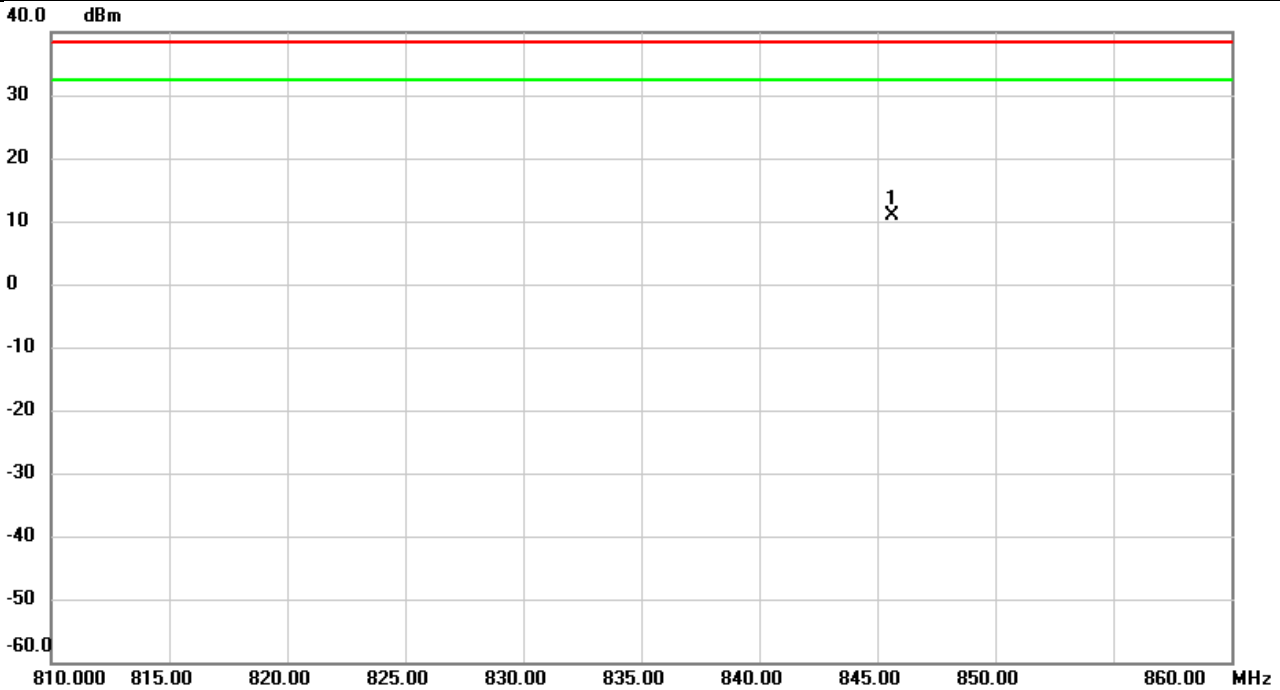

No.	Mk.	Freq. MHz	Reading Level dBm	Correct Factor dB	Measure- ment dBm	Limit dBm	Over dB	Detector	Comment
1	*	845.6350	-22.68	33.50	10.82	38.45	-27.63	peak	

REMARKS:

- (1) Measurement Value = Reading Level + Correct Factor.
- (2) Margin Level = Measurement Value - Limit Value.

Test Mode	WCDMA Band V	Test Date	2021/3/25
Test Channel	CH4407	Polarization	Vertical
Temp	21°C	Hum.	68%

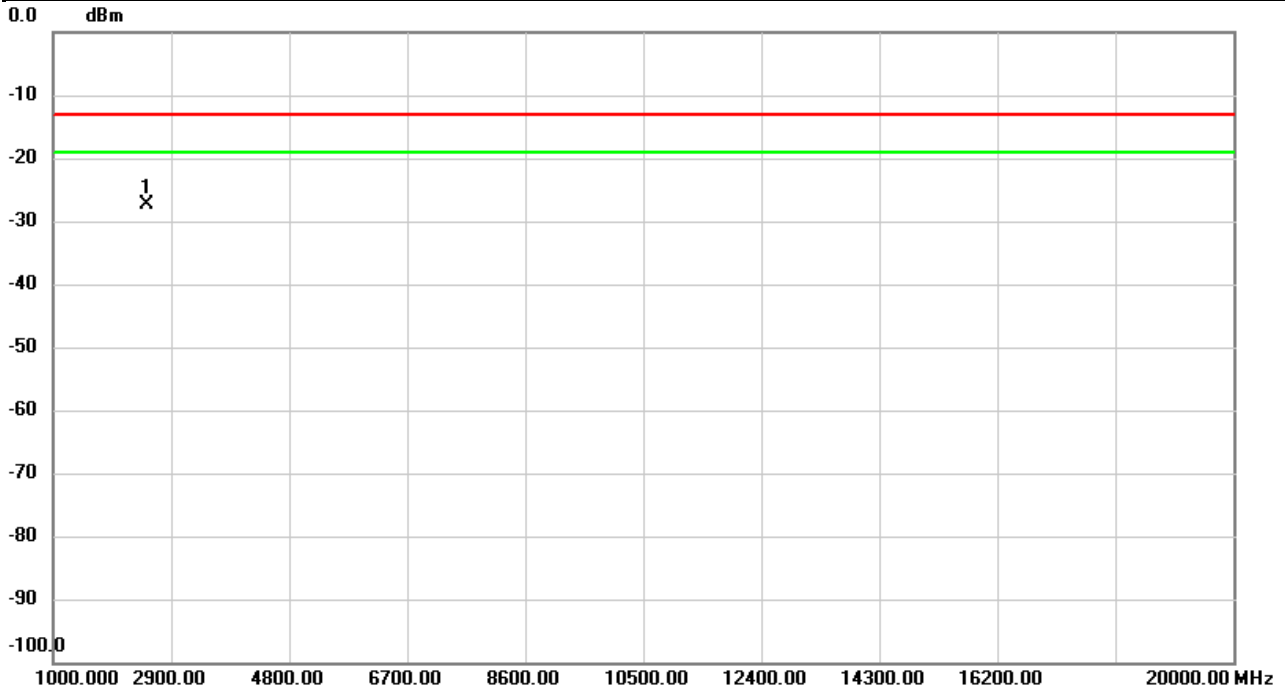

No.	Mk.	Freq.	Reading Level	Correct Factor	Measurement	Limit	Over	Detector	Comment
		MHz	dBm	dB	dBm	dBm	dB		
1	*	2513.033	-23.26	-4.22	-27.48	-13.00	-14.48	peak	

REMARKS:

- (1) Measurement Value = Reading Level + Correct Factor.
- (2) Margin Level = Measurement Value - Limit Value.

Test Mode	WCDMA Band V	Test Date	2021/3/25
Test Channel	CH4407	Polarization	Horizontal
Temp	21°C	Hum.	68%

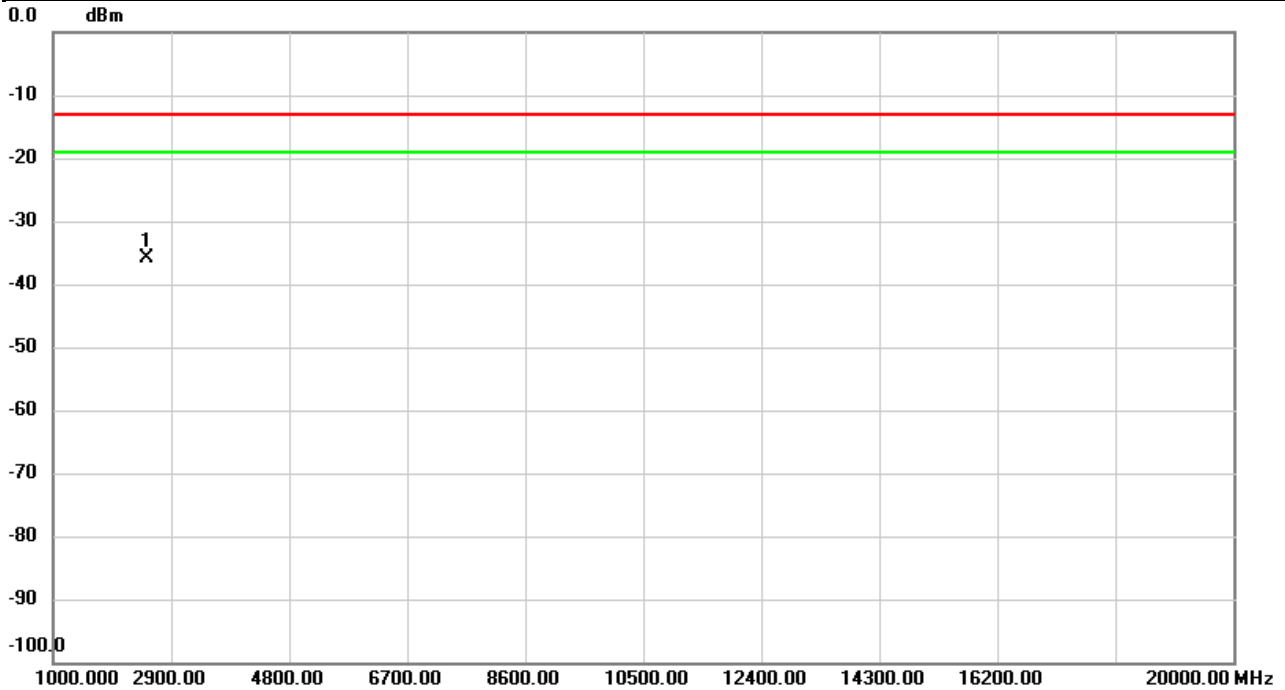

No.	Mk.	Freq.	Reading Level	Correct Factor	Measurement	Limit	Over	Detector	Comment
		MHz	dBm	dB	dBm	dBm	dB		
1	*	2513.033	-31.48	-4.45	-35.93	-13.00	-22.93	peak	

REMARKS:

- (1) Measurement Value = Reading Level + Correct Factor.
- (2) Margin Level = Measurement Value - Limit Value.

Test Mode	LTE Band 5	Test Date	2021/3/25
Test Channel	CH20525	Polarization	Vertical
Temp	21°C	Hum.	68%

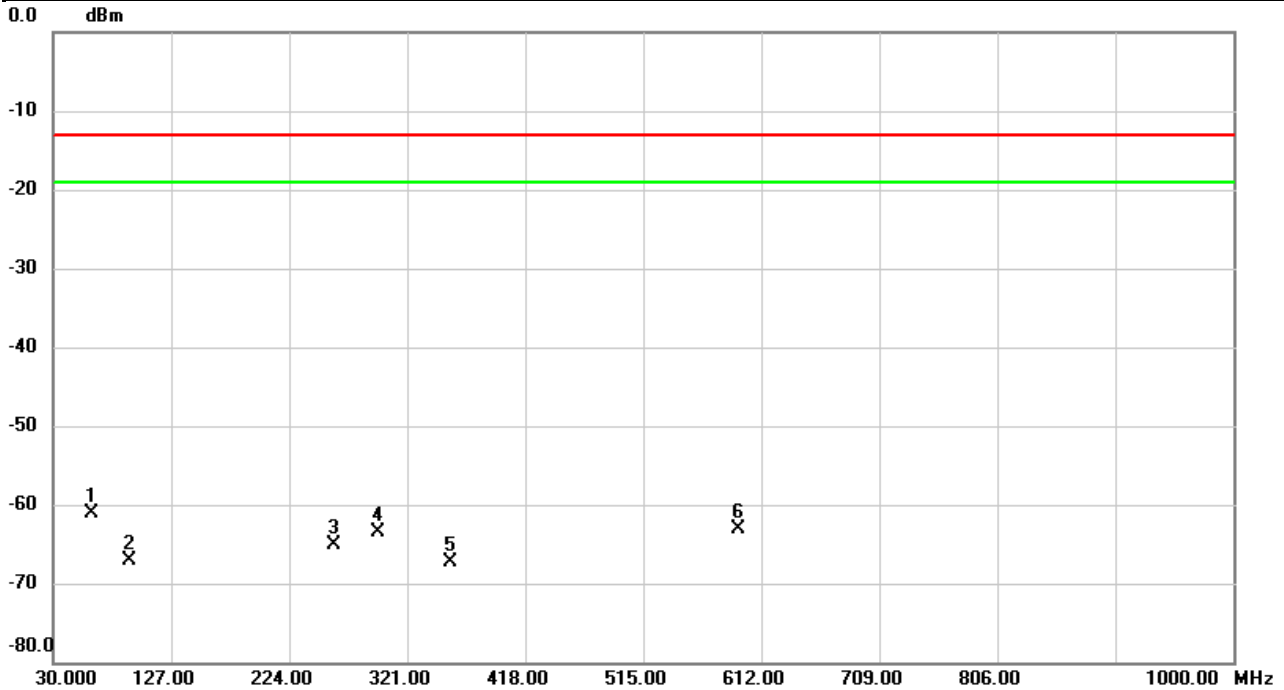

No.	Mk.	Freq.	Reading Level	Correct Factor	Measurement	Limit	Over	Detector	Comment
		MHz	dBm	dB	dBm	dBm	dB		
1	*	61.0400	-59.61	-1.44	-61.05	-13.00	-48.05	peak	
2		92.0800	-65.99	-1.08	-67.07	-13.00	-54.07	peak	
3		260.8600	-72.75	7.70	-65.05	-13.00	-52.05	peak	
4		296.7500	-71.14	7.62	-63.52	-13.00	-50.52	peak	
5		355.9200	-73.43	6.14	-67.29	-13.00	-54.29	peak	
6		593.5700	-74.91	11.75	-63.16	-13.00	-50.16	peak	

REMARKS:

- (1) Measurement Value = Reading Level + Correct Factor.
- (2) Margin Level = Measurement Value - Limit Value.

Test Mode	LTE Band 5	Test Date	2021/3/25
Test Channel	CH20525	Polarization	Horizontal
Temp	21°C	Hum.	68%

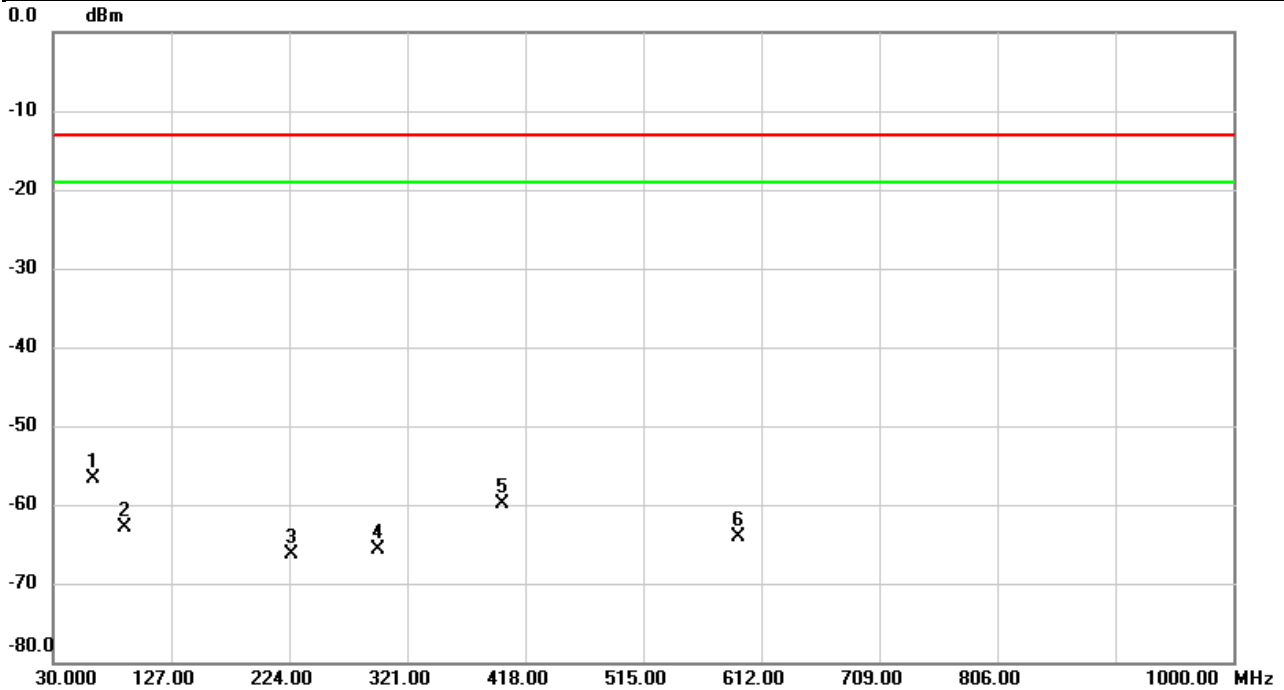

No.	Mk.	Freq.	Reading Level	Correct Factor	Measurement	Limit	Over	Detector	Comment
		MHz	dBm	dB	dBm	dBm	dB		
1	*	62.9800	-62.87	6.15	-56.72	-13.00	-43.72	peak	
2		89.1700	-66.79	3.83	-62.96	-13.00	-49.96	peak	
3		225.9400	-65.49	-0.76	-66.25	-13.00	-53.25	peak	
4		296.7500	-66.46	0.76	-65.70	-13.00	-52.70	peak	
5		398.6000	-66.08	6.12	-59.96	-13.00	-46.96	peak	
6		593.5700	-71.61	7.44	-64.17	-13.00	-51.17	peak	

REMARKS:

- (1) Measurement Value = Reading Level + Correct Factor.
- (2) Margin Level = Measurement Value - Limit Value.

Test Mode	LTE Band 5	Test Date	2021/3/24
Test Channel	CH20450	Polarization	Vertical
Temp	21°C	Hum.	68%

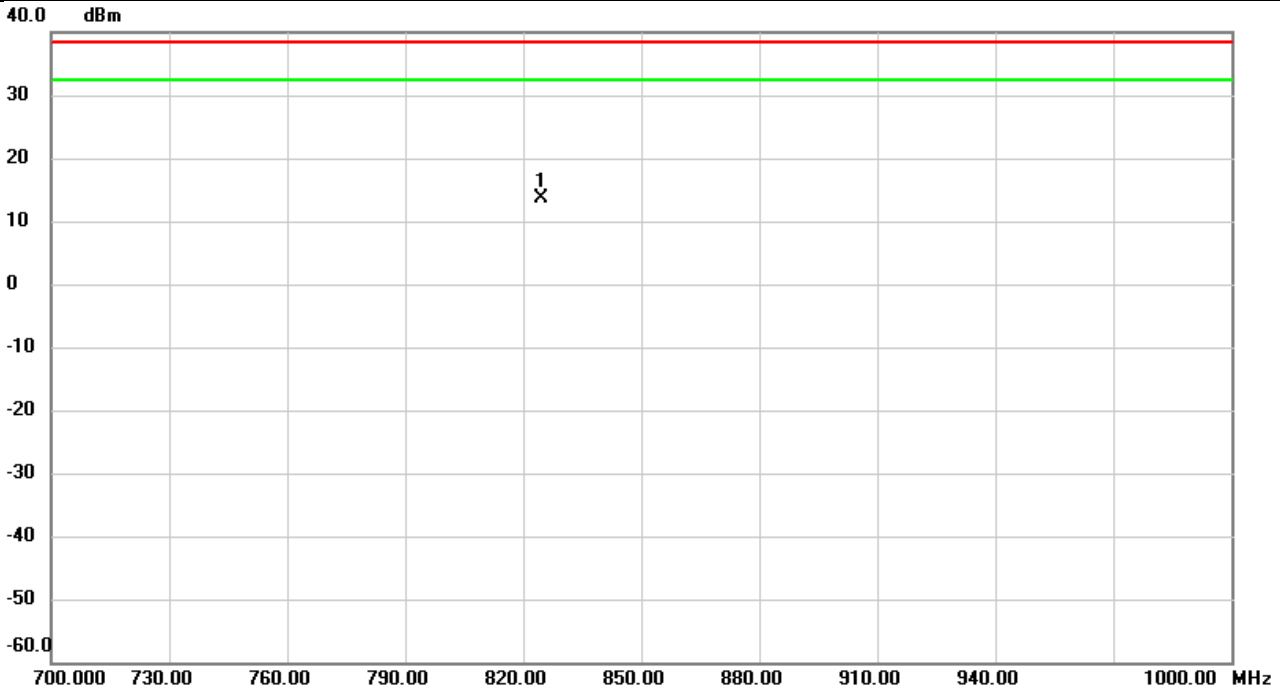

No.	Mk.	Freq.	Reading Level	Correct Factor	Measurement	Limit	Over	Detector	Comment
		MHz	dBm	dB	dBm	dBm	dB		
1	*	824.6000	-20.62	34.27	13.65	38.45	-24.80	peak	

REMARKS:

- (1) Measurement Value = Reading Level + Correct Factor.
- (2) Margin Level = Measurement Value - Limit Value.

Test Mode	LTE Band 5	Test Date	2021/3/24
Test Channel	CH20450	Polarization	Horizontal
Temp	21°C	Hum.	68%

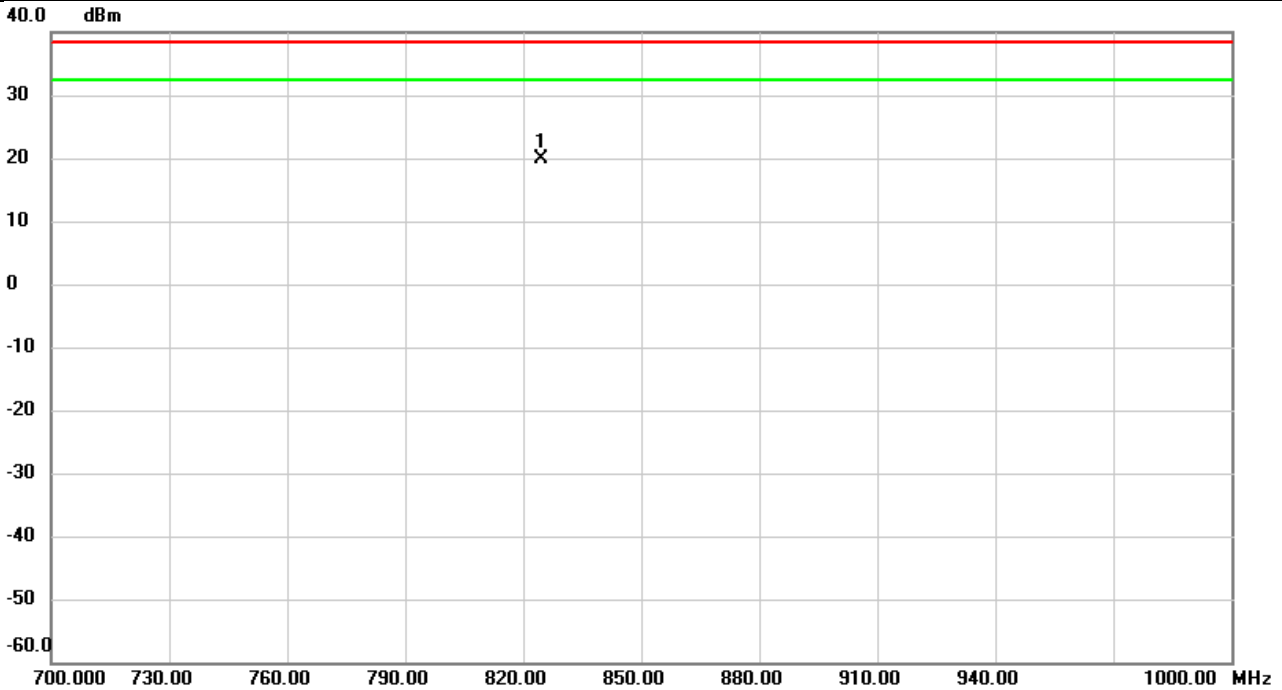

No.	Mk.	Freq.	Reading Level	Correct Factor	Measurement	Limit	Over	Detector	Comment
		MHz	dBm	dB	dBm	dBm	dB		
1	*	824.6300	-13.58	33.55	19.97	38.45	-18.48	peak	

REMARKS:

- (1) Measurement Value = Reading Level + Correct Factor.
- (2) Margin Level = Measurement Value - Limit Value.

Test Mode	LTE Band 5	Test Date	2021/3/25
Test Channel	CH20525	Polarization	Vertical
Temp	21°C	Hum.	68%

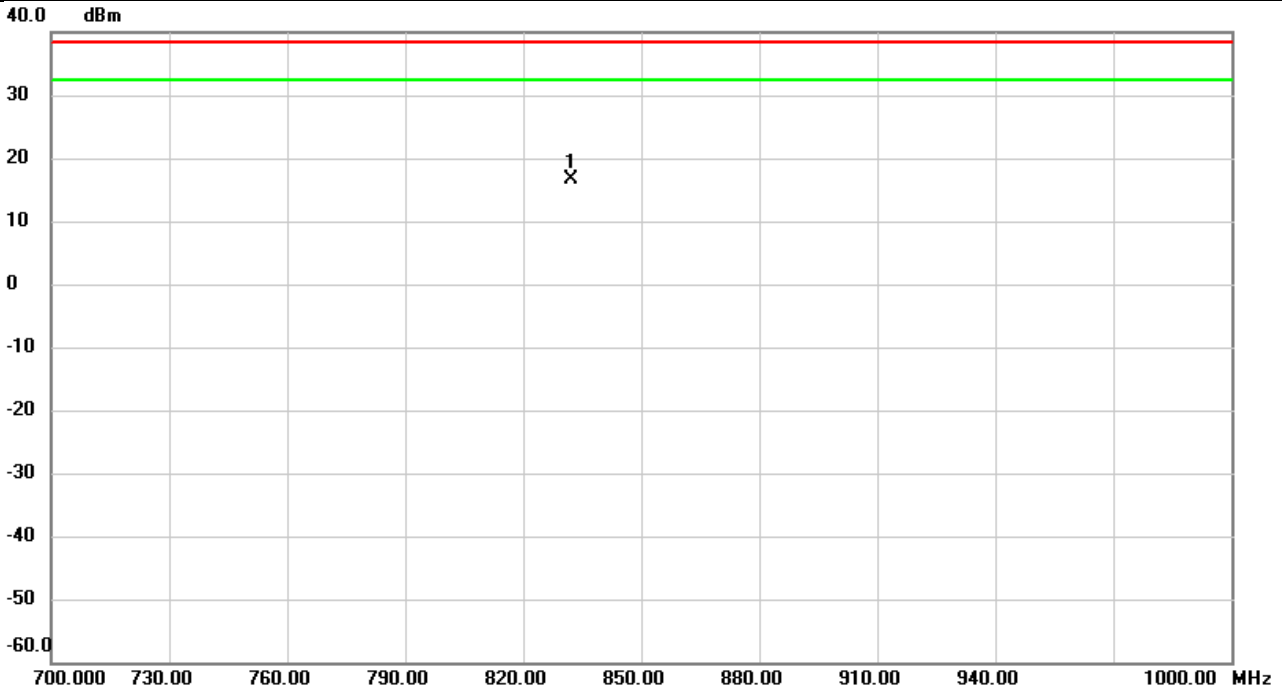

No.	Mk.	Freq.	Reading Level	Correct Factor	Measurement	Limit	Over	Detector	Comment
		MHz	dBm	dB	dBm	dBm	dB		
1	*	832.1100	-17.62	34.24	16.62	38.45	-21.83	peak	

REMARKS:

- (1) Measurement Value = Reading Level + Correct Factor.
- (2) Margin Level = Measurement Value - Limit Value.

Test Mode	LTE Band 5	Test Date	2021/3/25
Test Channel	CH20525	Polarization	Horizontal
Temp	21°C	Hum.	68%

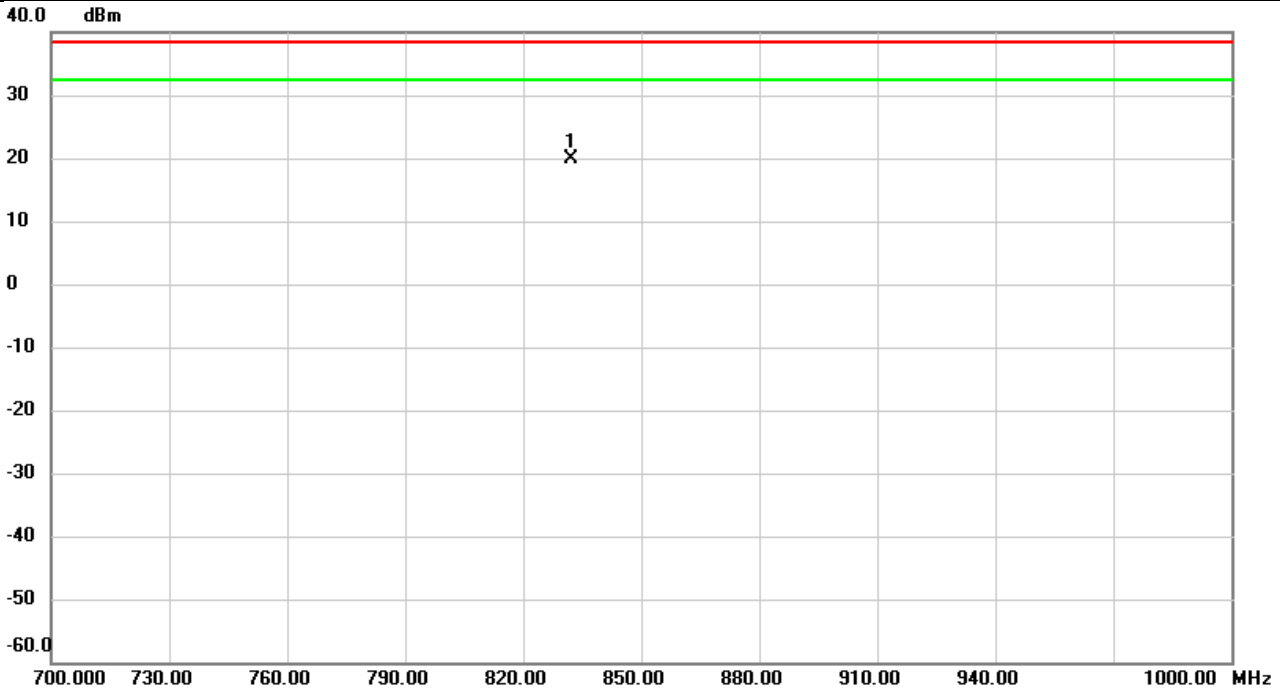

No.	Mk.	Freq.	Reading Level	Correct Factor	Measurement	Limit	Over	Detector	Comment
		MHz	dBm	dB	dBm	dBm	dB		
1	*	832.1000	-13.53	33.53	20.00	38.45	-18.45	peak	

REMARKS:

- (1) Measurement Value = Reading Level + Correct Factor.
- (2) Margin Level = Measurement Value - Limit Value.

Test Mode	LTE Band 5	Test Date	2021/3/25
Test Channel	CH20600	Polarization	Vertical
Temp	21°C	Hum.	68%

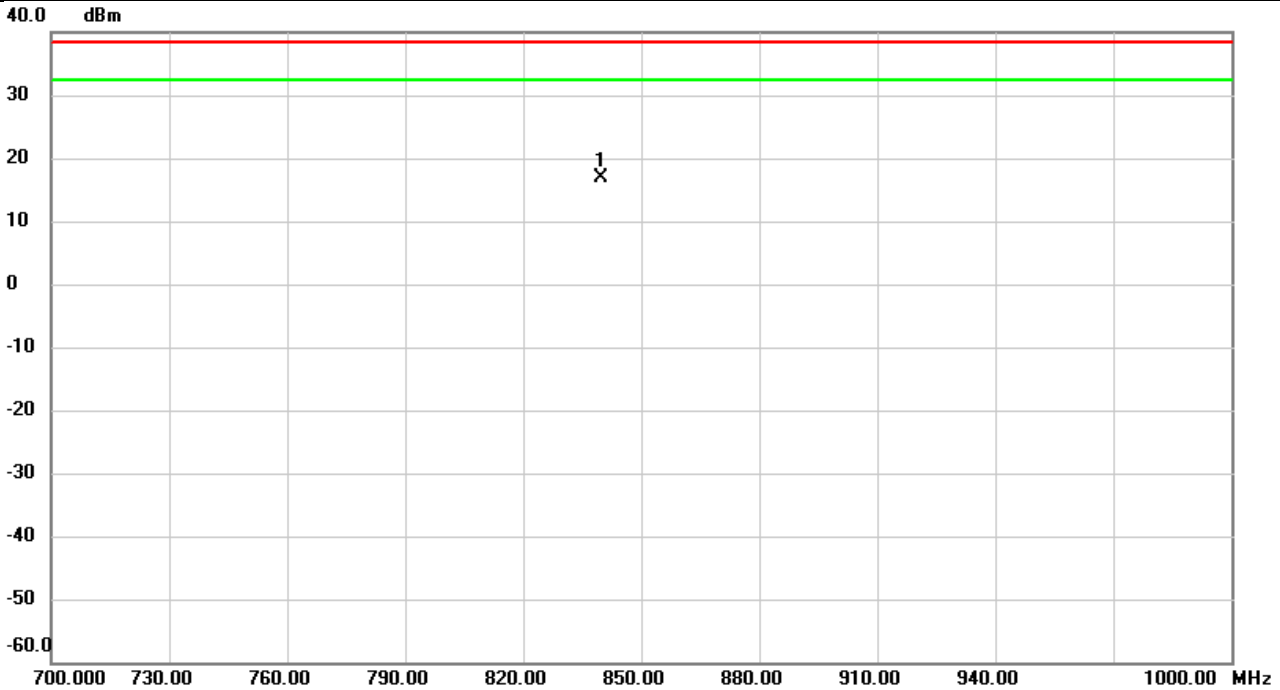

No.	Mk.	Freq.	Reading Level	Correct Factor	Measurement	Limit	Over	Detector	Comment
		MHz	dBm	dB	dBm	dBm	dB		
1	*	839.6200	-17.25	34.22	16.97	38.45	-21.48	peak	

REMARKS:

- (1) Measurement Value = Reading Level + Correct Factor.
- (2) Margin Level = Measurement Value - Limit Value.

Test Mode	LTE Band 5	Test Date	2021/3/25
Test Channel	CH20600	Polarization	Horizontal
Temp	21°C	Hum.	68%

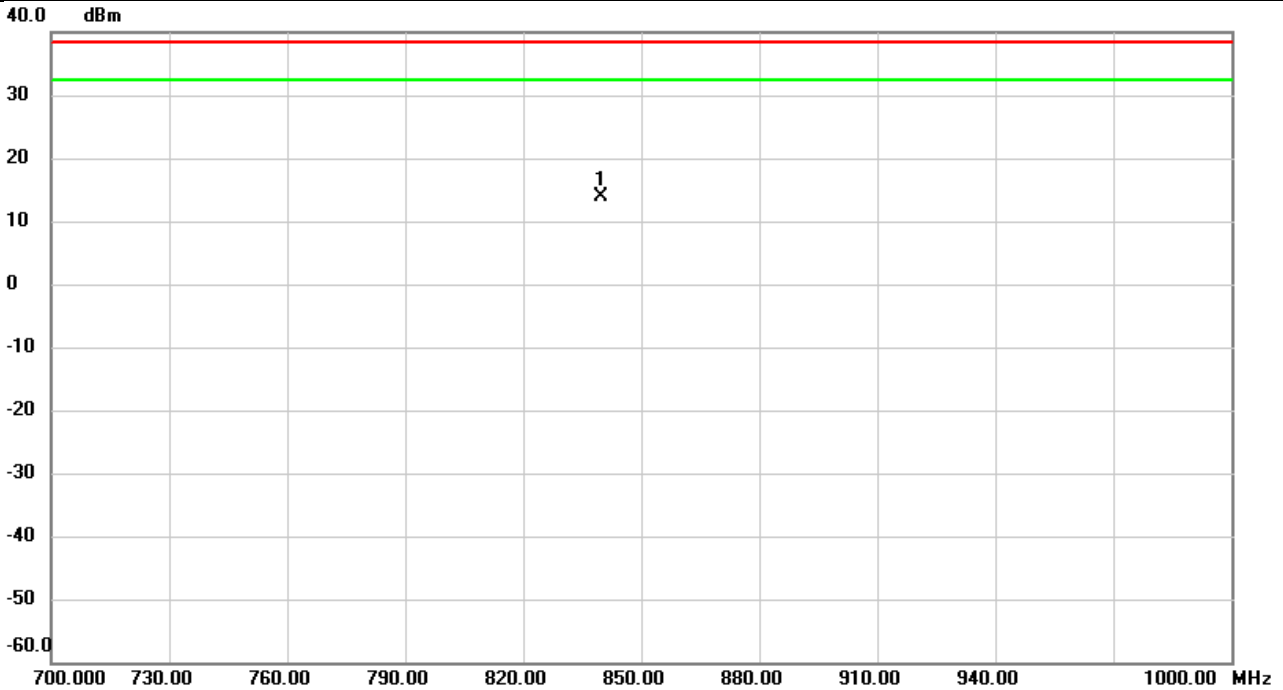

No.	Mk.	Freq.	Reading Level	Correct Factor	Measurement	Limit	Over	Detector	Comment
		MHz	dBm	dB	dBm	dBm	dB		
1	*	839.9000	-19.65	33.51	13.86	38.45	-24.59	peak	

REMARKS:

- (1) Measurement Value = Reading Level + Correct Factor.
- (2) Margin Level = Measurement Value - Limit Value.

Test Mode	LTE Band 5	Test Date	2021/3/25
Test Channel	CH20525	Polarization	Vertical
Temp	21°C	Hum.	68%

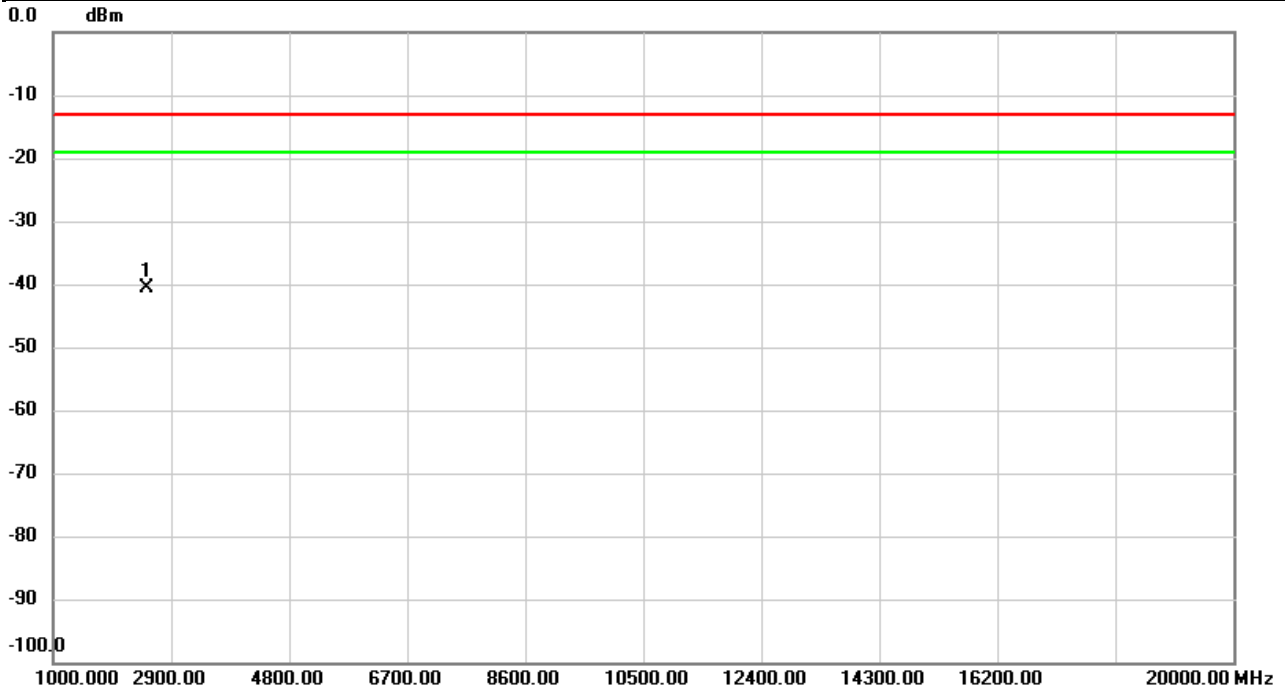

No.	Mk.	Freq.	Reading Level	Correct Factor	Measurement	Limit	Over	Detector	Comment
		MHz	dBm	dB	dBm	dBm	dB		
1	*	2496.567	-36.21	-4.35	-40.56	-13.00	-27.56	peak	

REMARKS:

- (1) Measurement Value = Reading Level + Correct Factor.
- (2) Margin Level = Measurement Value - Limit Value.

Test Mode	LTE Band 5	Test Date	2021/3/25
Test Channel	CH20525	Polarization	Horizontal
Temp	21°C	Hum.	68%

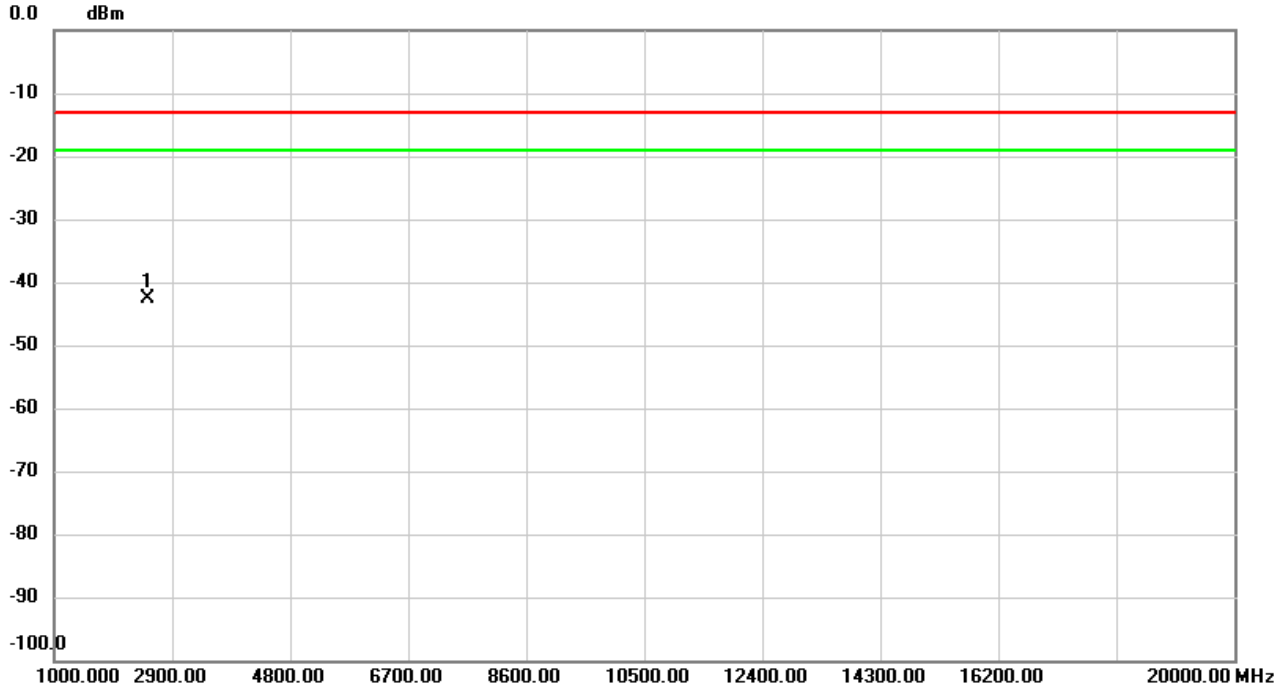

No.	Mk.	Freq.	Reading Level	Correct Factor	Measurement	Limit	Over	Detector	Comment
		MHz	dBm	dB	dBm	dBm	dB		
1	*	2496.567	-38.23	-4.35	-42.58	-13.00	-29.58	peak	

REMARKS:

- (1) Measurement Value = Reading Level + Correct Factor.
- (2) Margin Level = Measurement Value - Limit Value.

Test Mode	LTE Band 26	Test Date	2021/3/25
Test Channel	CH26915	Polarization	Vertical
Temp	21°C	Hum.	68%

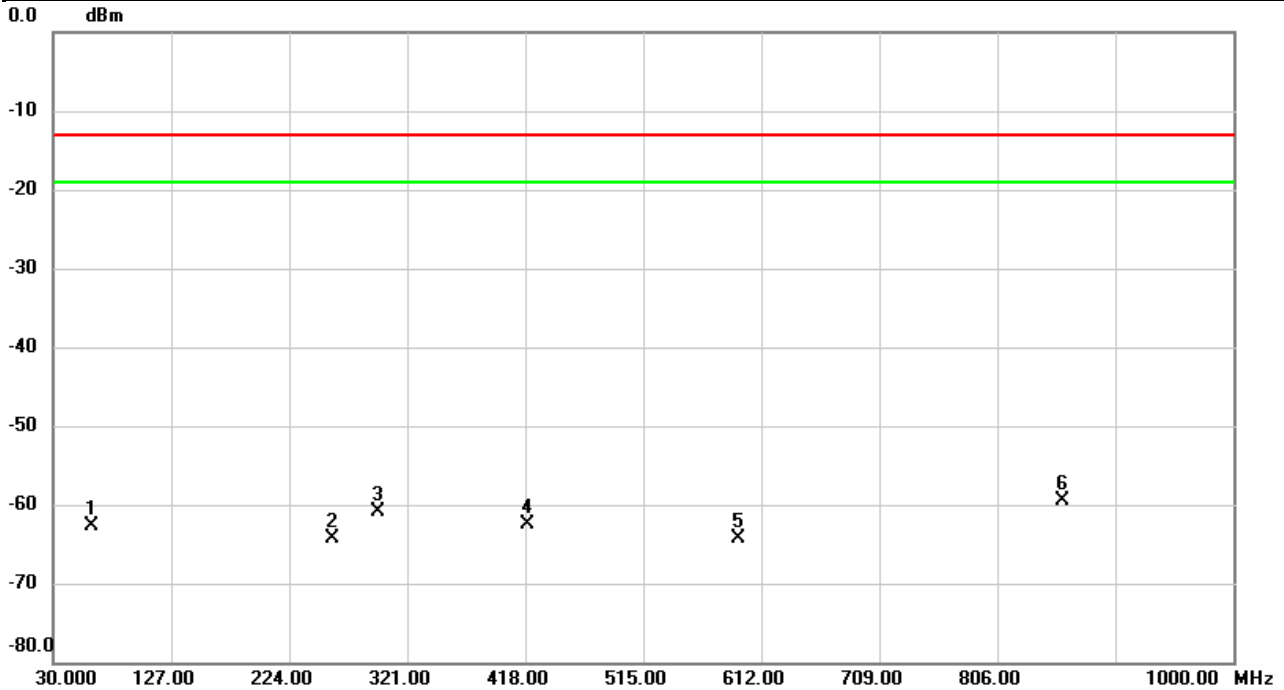

No.	Mk.	Freq. MHz	Reading Level dBm	Correct Factor dB	Measure- ment dBm	Limit dBm	Over dB	Detector	Comment
1		61.4602	-61.29	-1.49	-62.78	-13.00	-49.78	peak	
2		259.3080	-72.00	7.71	-64.29	-13.00	-51.29	peak	
3		296.7175	-68.61	7.62	-60.99	-13.00	-47.99	peak	
4		420.0370	-65.07	2.50	-62.57	-13.00	-49.57	peak	
5		593.3760	-75.96	11.74	-64.22	-13.00	-51.22	peak	
6	*	860.2553	-69.42	10.00	-59.42	-13.00	-46.42	peak	

REMARKS:

- (1) Measurement Value = Reading Level + Correct Factor.
- (2) Margin Level = Measurement Value - Limit Value.

Test Mode	LTE Band 26	Test Date	2021/3/25
Test Channel	CH26915	Polarization	Horizontal
Temp	21°C	Hum.	68%

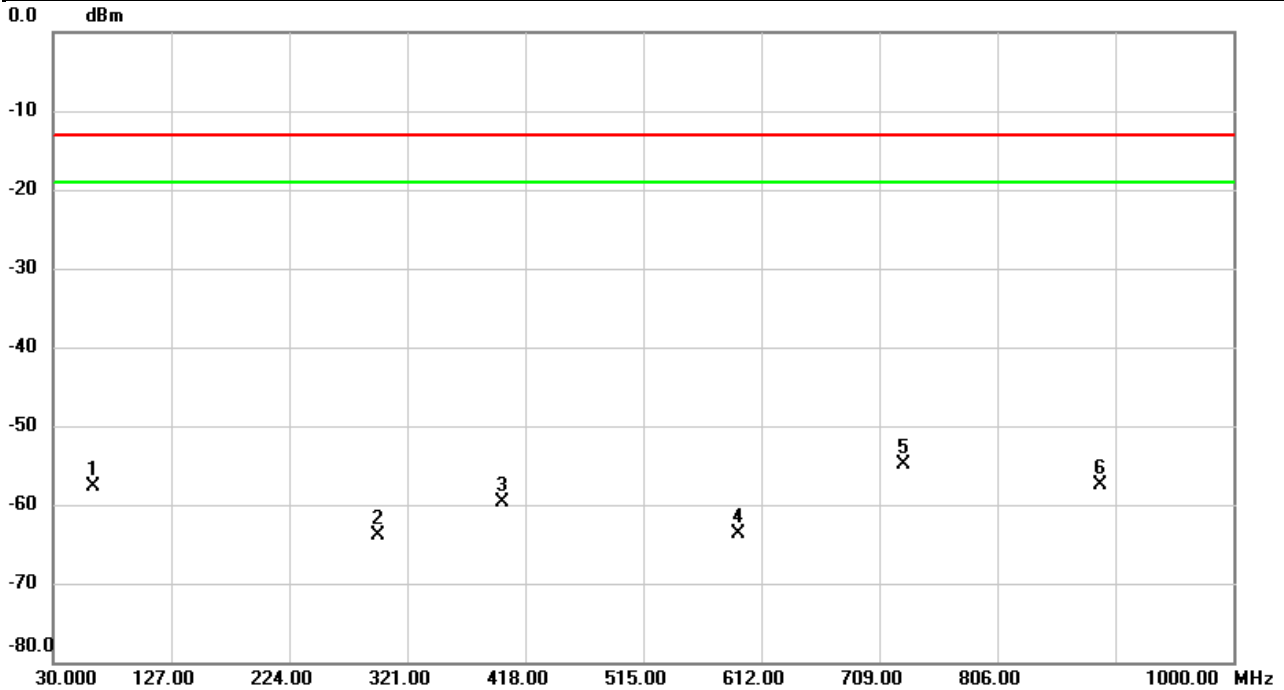

No.	Mk.	Freq. MHz	Reading Level dBm	Correct Factor dB	Measure- ment dBm	Limit dBm	Over dB	Detector	Comment
1		63.0446	-63.81	6.13	-57.68	-13.00	-44.68	peak	
2		296.7175	-64.66	0.76	-63.90	-13.00	-50.90	peak	
3		398.6322	-65.87	6.12	-59.75	-13.00	-46.75	peak	
4		593.4083	-71.07	7.45	-63.62	-13.00	-50.62	peak	
5	*	729.2730	-66.23	11.36	-54.87	-13.00	-41.87	peak	
6		890.0990	-73.42	15.86	-57.56	-13.00	-44.56	peak	

REMARKS:

- (1) Measurement Value = Reading Level + Correct Factor.
- (2) Margin Level = Measurement Value - Limit Value.

Test Mode	LTE Band 26	Test Date	2021/3/25
Test Channel	CH26865	Polarization	Vertical
Temp	21°C	Hum.	68%

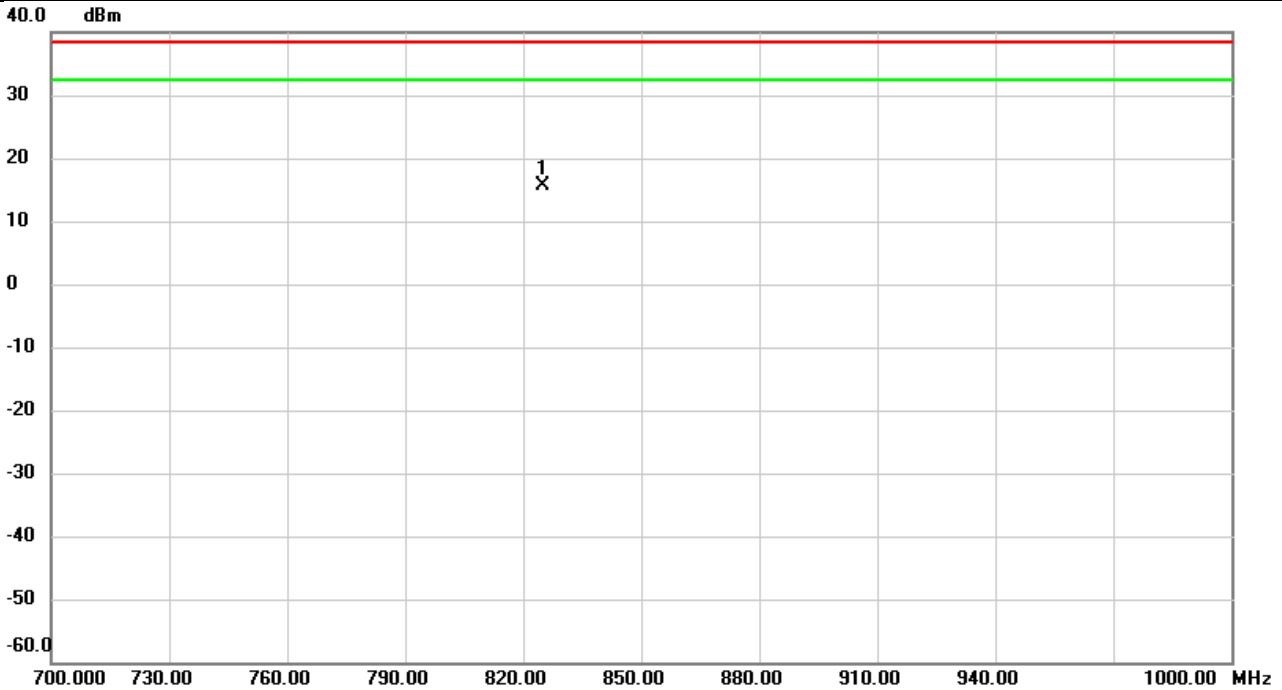

No.	Mk.	Freq.	Reading Level	Correct Factor	Measurement	Limit	Over	Detector	Comment
		MHz	dBm	dB	dBm	dBm	dB		
1	*	824.8600	-18.54	34.27	15.73	38.45	-22.72	peak	

REMARKS:

- (1) Measurement Value = Reading Level + Correct Factor.
- (2) Margin Level = Measurement Value - Limit Value.

Test Mode	LTE Band 26	Test Date	2021/3/25
Test Channel	CH26865	Polarization	Horizontal
Temp	21°C	Hum.	68%

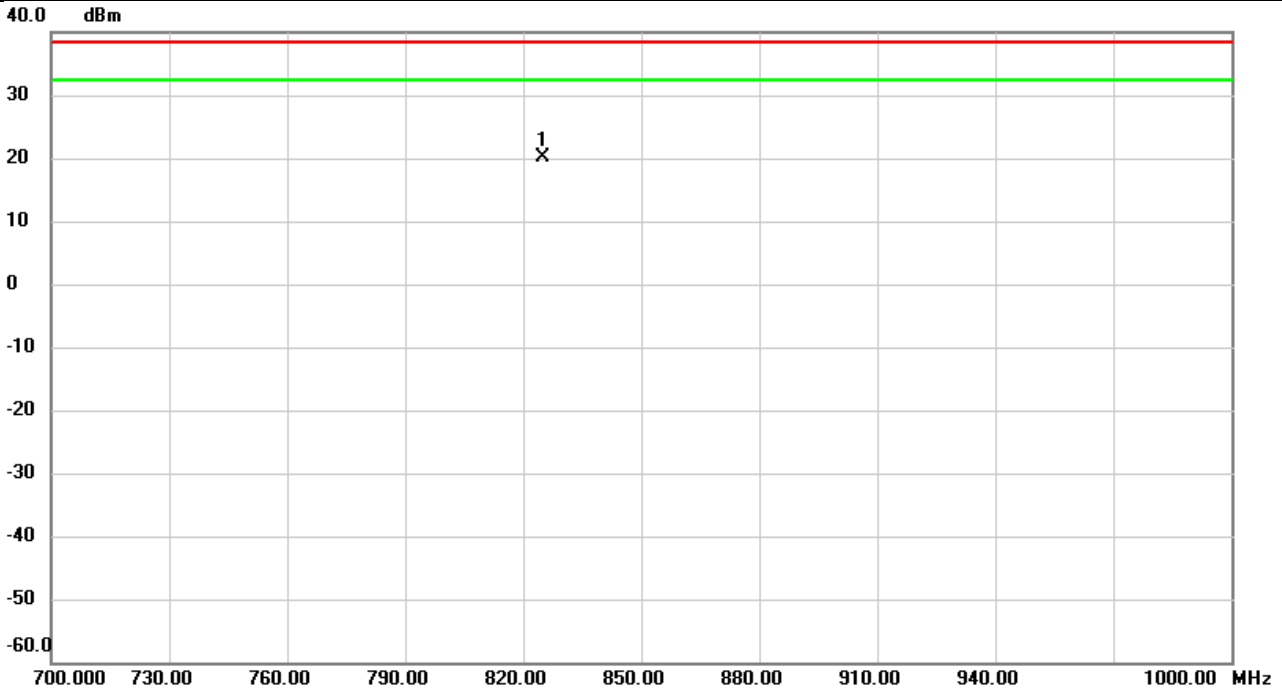

No.	Mk.	Freq.	Reading Level	Correct Factor	Measurement	Limit	Over	Detector	Comment
		MHz	dBm	dB	dBm	dBm	dB		
1	*	824.8700	-13.32	33.55	20.23	38.45	-18.22	peak	

REMARKS:

- (1) Measurement Value = Reading Level + Correct Factor.
- (2) Margin Level = Measurement Value - Limit Value.

Test Mode	LTE Band 26	Test Date	2021/3/25
Test Channel	CH26915	Polarization	Vertical
Temp	21°C	Hum.	68%

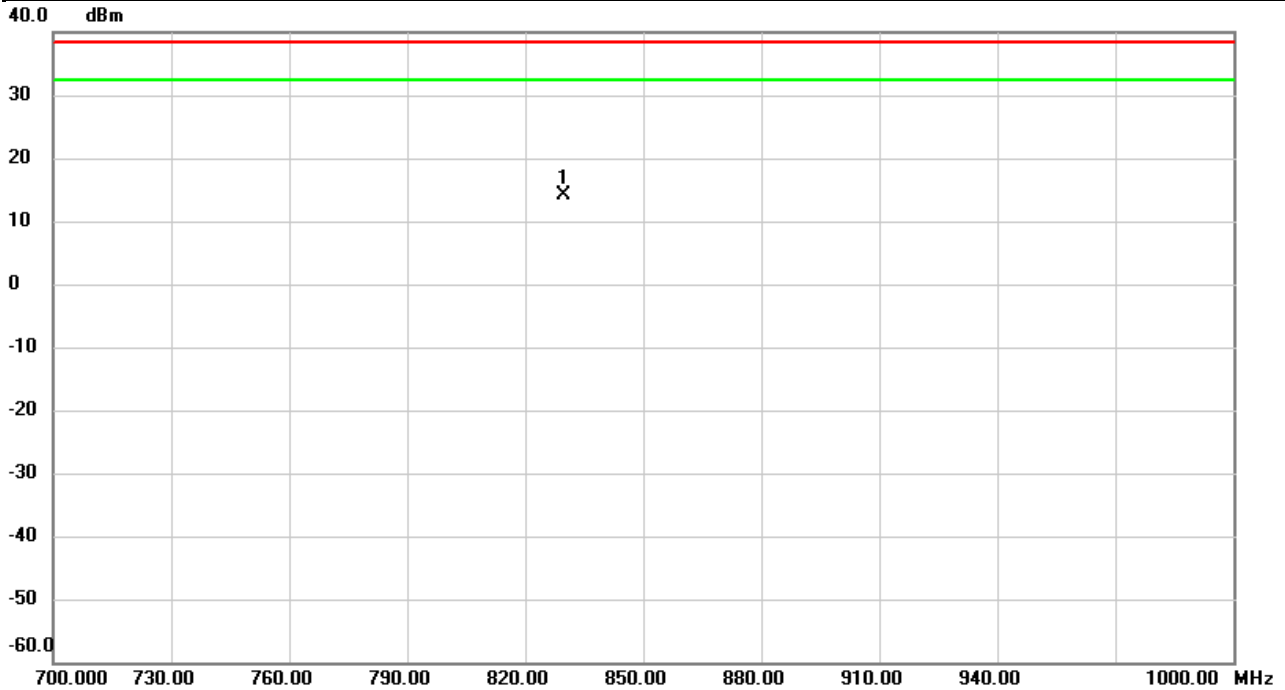

No.	Mk.	Freq.	Reading Level	Correct Factor	Measurement	Limit	Over	Detector	Comment
		MHz	dBm	dB	dBm	dBm	dB		
1	*	829.8000	-22.37	36.40	14.03	38.45	-24.42	peak	

REMARKS:

- (1) Measurement Value = Reading Level + Correct Factor.
- (2) Margin Level = Measurement Value - Limit Value.

Test Mode	LTE Band 26	Test Date	2021/3/25
Test Channel	CH26915	Polarization	Horizontal
Temp	21°C	Hum.	68%

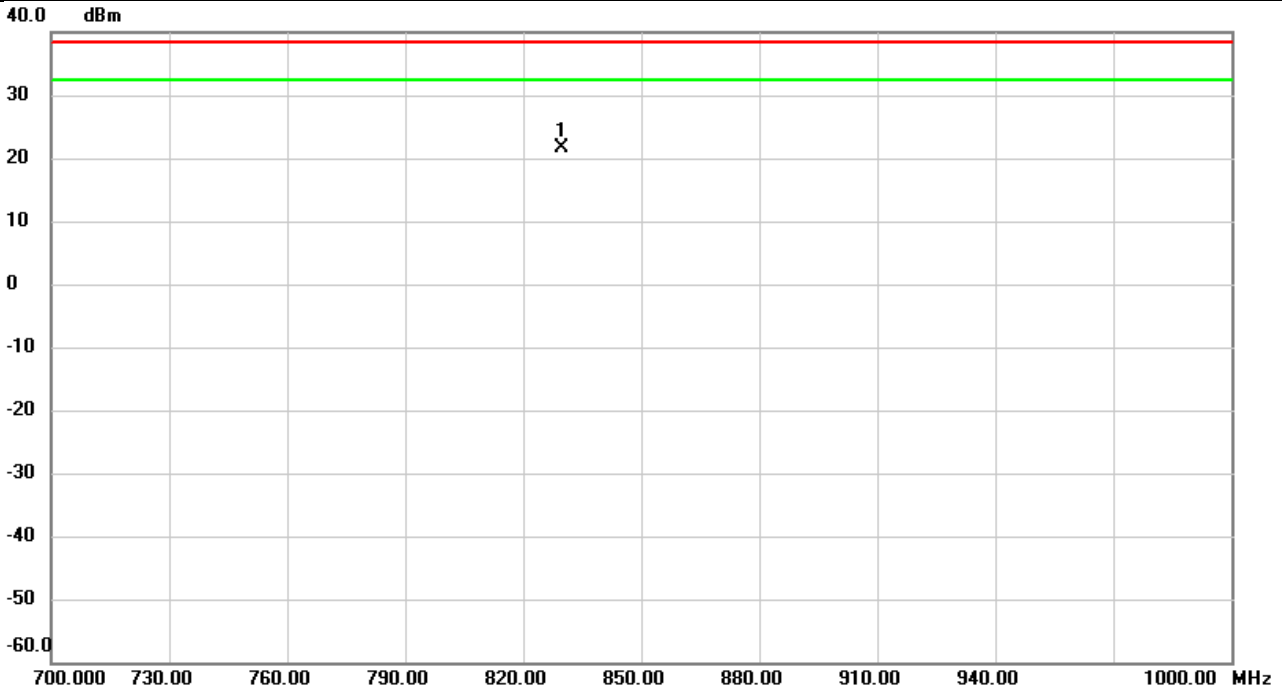

No.	Mk.	Freq.	Reading Level	Correct Factor	Measurement	Limit	Over	Detector	Comment
		MHz	dBm	dB	dBm	dBm	dB		
1	*	829.8000	-13.97	35.69	21.72	38.45	-16.73	peak	

REMARKS:

- (1) Measurement Value = Reading Level + Correct Factor.
- (2) Margin Level = Measurement Value - Limit Value.

Test Mode	LTE Band 26	Test Date	2021/3/25
Test Channel	CH26965	Polarization	Vertical
Temp	21°C	Hum.	68%

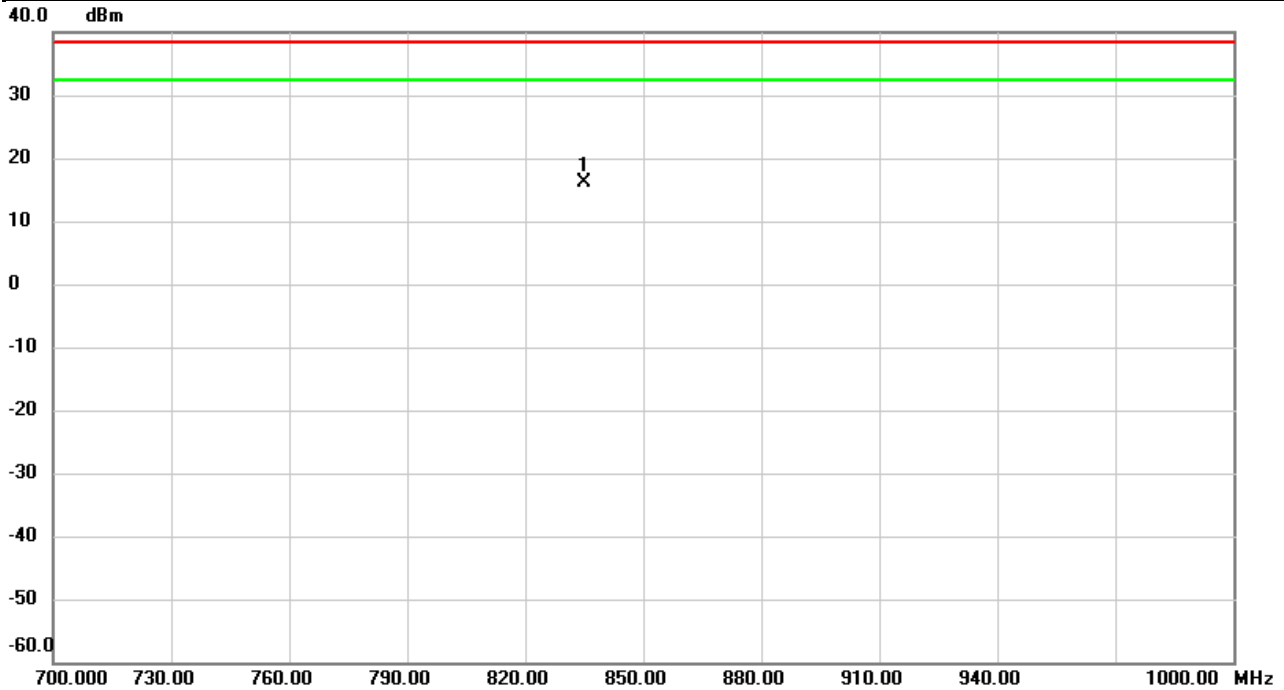

No.	Mk.	Freq.	Reading Level	Correct Factor	Measurement	Limit	Over	Detector	Comment
		MHz	dBm	dB	dBm	dBm	dB		
1	*	834.9700	-18.06	34.24	16.18	38.45	-22.27	peak	

REMARKS:

- (1) Measurement Value = Reading Level + Correct Factor.
- (2) Margin Level = Measurement Value - Limit Value.

Test Mode	LTE Band 26	Test Date	2021/3/25
Test Channel	CH26965	Polarization	Horizontal
Temp	21°C	Hum.	68%

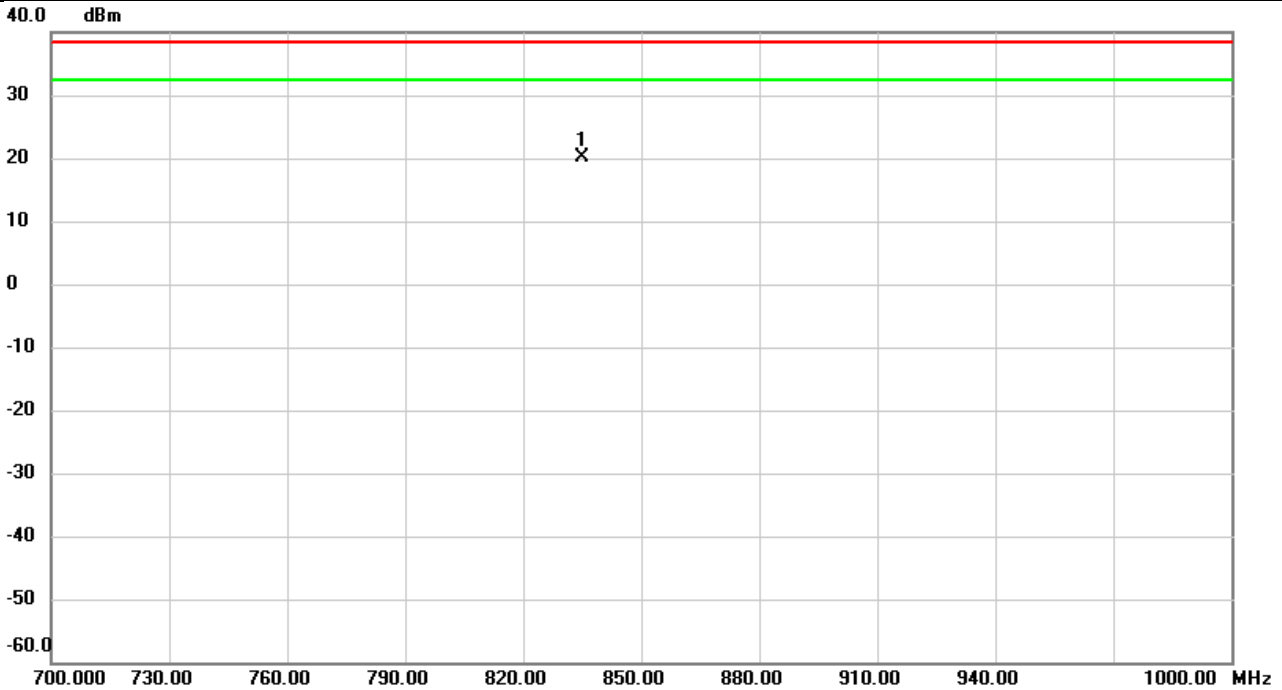

No.	Mk.	Freq.	Reading Level	Correct Factor	Measurement	Limit	Over	Detector	Comment
		MHz	dBm	dB	dBm	dBm	dB		
1	*	834.9000	-13.39	33.53	20.14	38.45	-18.31	peak	

REMARKS:

- (1) Measurement Value = Reading Level + Correct Factor.
- (2) Margin Level = Measurement Value - Limit Value.

Test Mode	LTE Band 26	Test Date	2021/3/25
Test Channel	CH26915	Polarization	Vertical
Temp	21°C	Hum.	68%

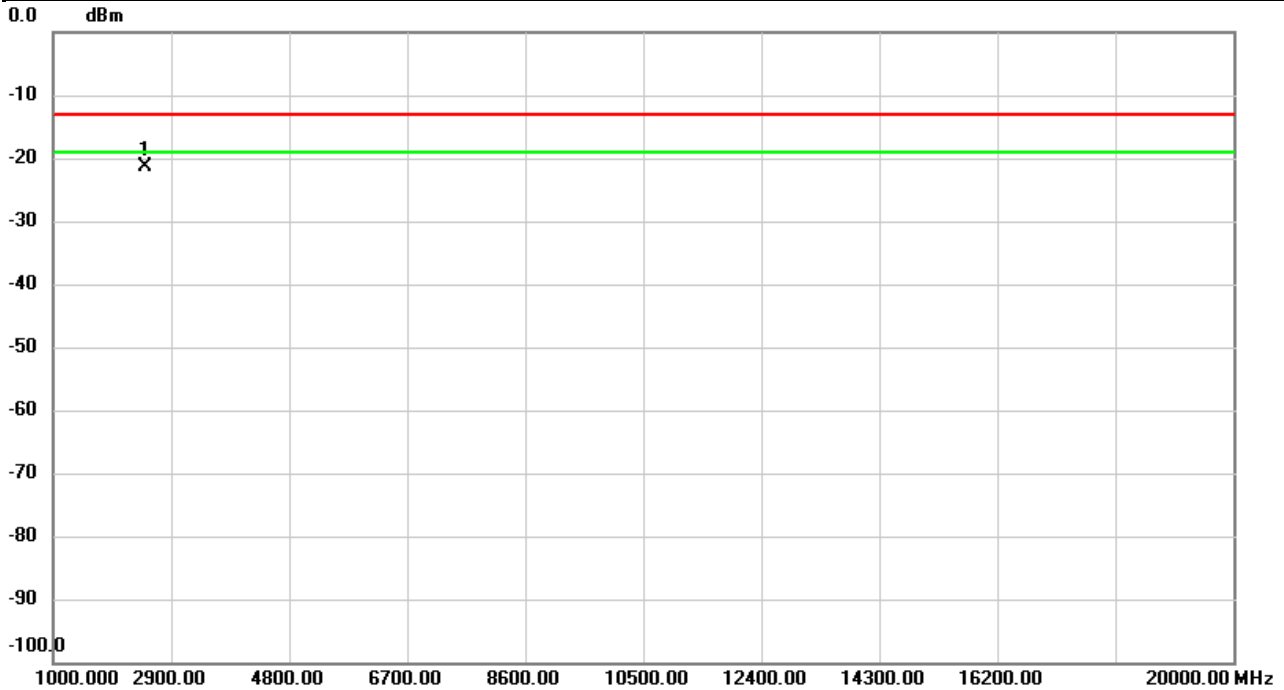

No.	Mk.	Freq.	Reading Level	Correct Factor	Measurement	Limit	Over	Detector	Comment
		MHz	dBm	dB	dBm	dBm	dB		
1	*	2489.600	-17.09	-4.36	-21.45	-13.00	-8.45	peak	

REMARKS:

- (1) Measurement Value = Reading Level + Correct Factor.
- (2) Margin Level = Measurement Value - Limit Value.

Test Mode	LTE Band 26	Test Date	2021/3/25
Test Channel	CH26915	Polarization	Horizontal
Temp	21°C	Hum.	68%

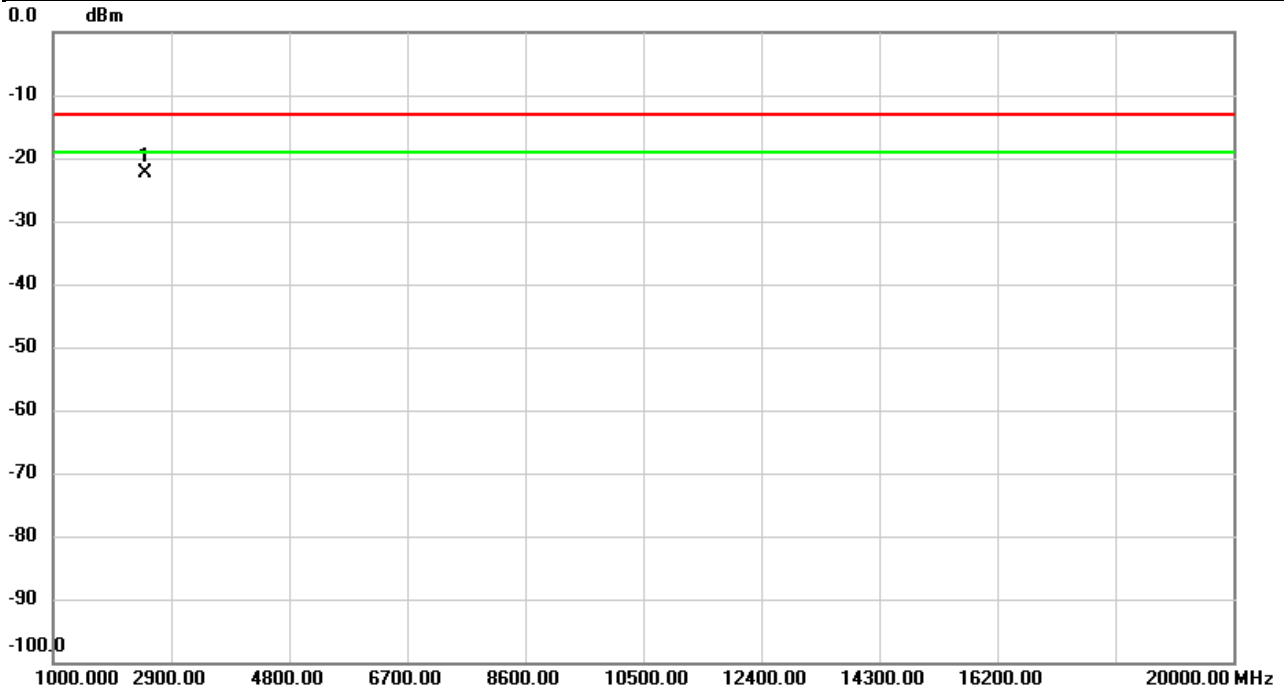

No.	Mk.	Freq.	Reading Level	Correct Factor	Measurement	Limit	Over	Detector	Comment
		MHz	dBm	dB	dBm	dBm	dB		
1	*	2489.600	-17.57	-4.73	-22.30	-13.00	-9.30	peak	

REMARKS:

- (1) Measurement Value = Reading Level + Correct Factor.
- (2) Margin Level = Measurement Value - Limit Value.

APPENDIX C REFERENCE INFORMATION

WCDMA Band V Power:

Band	Mode	UL/DL Channel No.	Frequency(MHz)	Average power(dBm)
WCDMA Band V	Rel 99	4132/4357	826.4	23.10
		4183/4408	836.4	23.51
		4233/4458	846.6	23.35

Band	Sub-test	UL/DL Channel No.	Average power(dBm)
HSDPA V	1	4132/4357	21.32
		4183/4408	21.40
		4233/4458	21.38
	2	4132/4357	20.87
		4183/4408	20.95
		4233/4458	20.93
	3	4132/4357	20.37
		4183/4408	20.45
		4233/4458	20.43
	4	4132/4357	20.42
		4183/4408	20.50
		4233/4458	20.48

Band	Sub-test	UL/DL Channel No.	Average power(dBm)
HSUPA V	1	4132/4157	19.46
		4182/4407	19.72
		4233/4458	19.89
	2	4132/4157	17.58
		4182/4407	17.84
		4233/4458	18.01
	3	4132/4157	18.58
		4182/4407	18.84
		4233/4458	19.01
	4	4132/4157	17.60
		4182/4407	17.86
		4233/4458	18.03
	5	4132/4157	19.37
		4182/4407	19.63
		4233/4458	19.80

LTE Band 5 Power:

Band	BW (MHz)	Channel	Frequency (MHz)	Mode	UL RB Allocation	UL RB Offset	MPR	Average power (dBm)		
5	1.4	20407	824.7	QPSK	1	0	0	22.36		
					1	2	0	22.12		
					1	5	0	22.06		
					3	0	0	22.36		
					3	1	0	22.12		
					3	2	0	22.06		
				16QAM	6	0	1	21.42		
					1	0	1	21.54		
					1	2	1	21.50		
					1	5	1	21.13		
					3	0	1	21.54		
					3	1	1	21.50		
		20525	836.5	QPSK	836.5	QPSK	3	2	1	21.13
							6	0	2	20.51
							1	0	0	22.16
							1	2	0	22.03
							1	5	0	21.88
							3	0	0	22.16
				16QAM	3	1	0	22.03		
					3	2	0	21.88		
					6	0	1	21.22		
					1	0	1	21.34		
					1	2	1	21.30		
					1	5	1	20.95		
		20642	848.2	QPSK	848.2	QPSK	3	0	1	21.34
							3	1	1	21.30
							3	2	1	20.95
							6	0	2	20.50
							1	0	0	22.25
							1	2	0	22.11
16QAM	1			5	0	21.86				
	3			0	0	22.25				
	3			1	0	22.11				
	3			2	0	21.86				
	6			0	1	21.31				
	1			0	1	21.43				
16QAM	1	2	1	21.39						
	1	5	1	20.93						
	3	0	1	21.43						
	3	1	1	21.39						
	3	2	1	20.93						
	6	0	2	20.60						

Band	BW (MHz)	Channel	Frequency (MHz)	Mode	UL RB Allocation	UL RB Offset	MPR	Average power (dBm)
5	3	20415	825.5	QPSK	1	0	0	22.41
					1	7	0	22.17
					1	14	0	22.11
					8	0	1	21.52
					8	4	1	21.21
					8	7	1	21.29
					15	0	1	21.47
				16QAM	1	0	1	21.59
					1	7	1	21.55
					1	14	1	21.18
					8	0	2	20.42
					8	4	2	20.31
					8	7	2	20.14
					15	0	2	20.56
					20525	836.5	QPSK	1
		1	7	0				22.08
		1	14	0				21.93
		8	0	1				21.32
		8	4	1				21.12
		8	7	1				21.11
		15	0	1				21.27
		16QAM	1	0			1	21.39
			1	7			1	21.35
			1	14			1	21.00
			8	0			2	20.22
			8	4			2	20.22
			8	7			2	19.96
			15	0			2	20.36
			20634	847.4			QPSK	1
		1			7	0		22.16
1	14	0			21.91			
8	0	1			21.41			
8	4	1			21.20			
8	7	1			21.09			
15	0	1			21.36			
16QAM	1	0			1	21.48		
	1	7			1	21.44		
	1	14			1	20.98		
	8	0			2	20.31		
	8	4			2	20.30		
	8	7			2	19.94		
	15	0			2	20.45		

Band	BW (MHz)	Channel	Frequency (MHz)	Mode	UL RB Allocation	UL RB Offset	MPR	Average power (dBm)		
5	5	20425	826.5	QPSK	1	0	0	22.46		
					1	12	0	22.22		
					1	24	0	22.16		
					12	0	1	21.57		
					12	6	1	21.26		
					12	11	1	21.34		
				16QAM	25	0	1	21.52		
					1	0	1	21.64		
					1	12	1	21.60		
					1	24	1	21.23		
					12	0	2	20.47		
					12	6	2	20.36		
		20525	836.5	QPSK	836.5	QPSK	12	11	2	20.19
							25	0	2	20.61
							1	0	0	22.26
							1	12	0	22.13
							1	24	0	21.98
							12	0	1	21.37
				16QAM	12	6	1	21.17		
					12	11	1	21.16		
					25	0	1	21.32		
					1	0	1	21.44		
					1	12	1	21.40		
					1	24	1	21.05		
		20625	846.5	QPSK	846.5	QPSK	12	0	2	20.27
							12	6	2	20.27
							12	11	2	20.01
							25	0	2	20.41
							1	0	0	22.35
							1	12	0	22.21
16QAM	1			24	0	21.96				
	12			0	1	21.46				
	12			6	1	21.25				
	12			11	1	21.14				
	25			0	1	21.41				
	1			0	1	21.53				
16QAM	1	12	1	21.49						
	1	24	1	21.03						
	12	0	2	20.36						
	12	6	2	20.35						
	12	11	2	19.99						
	25	0	2	20.50						

Band	BW (MHz)	Channel	Frequency (MHz)	Mode	UL RB Allocation	UL RB Offset	MPR	Average power (dBm)		
5	10	20450	829.0	QPSK	1	0	0	22.51		
					1	24	0	22.27		
					1	49	0	22.21		
					25	0	1	21.62		
					25	12	1	21.31		
					25	24	1	21.39		
				16QAM	50	0	1	21.57		
					1	0	1	21.69		
					1	24	1	21.65		
					1	49	1	21.28		
					25	0	2	20.52		
					25	12	2	20.41		
		20525	836.5	QPSK	836.5	QPSK	25	24	2	20.24
							50	0	2	20.66
							1	0	0	22.31
							1	24	0	22.18
							1	49	0	22.03
							25	0	1	21.42
				16QAM	25	12	1	21.22		
					25	24	1	21.21		
					50	0	1	21.37		
					1	0	1	21.49		
					1	24	1	21.45		
					1	49	1	21.10		
		20600	844.0	QPSK	844.0	QPSK	25	0	2	20.32
							25	12	2	20.32
							25	24	2	20.06
							50	0	2	20.46
							1	0	0	22.40
							1	24	0	22.26
16QAM	1			49	0	22.01				
	25			0	1	21.51				
	25			12	1	21.30				
	25			24	1	21.19				
	50			0	1	21.46				
	1			0	1	21.58				
16QAM	1	24	1	21.54						
	1	49	1	21.08						
	25	0	2	20.41						
	25	12	2	20.40						
	25	24	2	20.04						
	50	0	2	20.55						

LTE Band 26 Power:

Band	BW (MHz)	Channel	Frequency (MHz)	Mode	UL RB Allocation	UL RB Offset	MPR	Average power (dBm)	
26	1.4	26797	824.7	QPSK	1	0	0	22.11	
					1	2	0	22.01	
					1	5	0	21.92	
					3	0	0	22.11	
					3	1	0	22.01	
					3	2	0	21.92	
				16QAM	6	0	1	21.17	
					1	0	1	21.29	
					1	2	1	21.25	
					1	5	1	20.99	
					3	0	1	21.29	
					3	1	1	21.25	
		26915	836.5	QPSK	836.5	3	2	1	20.99
						6	0	2	20.26
						1	0	0	21.99
						1	2	0	21.92
						1	5	0	21.83
						3	0	0	21.99
				16QAM	3	1	0	21.92	
					3	2	0	21.83	
					6	0	1	21.05	
					1	0	1	21.17	
					1	2	1	21.13	
					1	5	1	20.90	
		27033	848.3	QPSK	848.3	3	0	1	21.17
						3	1	1	21.13
						3	2	1	20.90
						6	0	2	20.50
						1	0	0	22.03
						1	2	0	21.97
16QAM	1			5	0	21.93			
	3			0	0	22.03			
	3			1	0	21.97			
	3			2	0	21.93			
	6			0	1	21.09			
	1			0	1	21.21			
16QAM	1	2	1	21.17					
	1	5	1	21.00					
	3	0	1	21.21					
	3	1	1	21.17					
	3	2	1	21.00					
	6	0	2	20.60					

Band	BW (MHz)	Channel	Frequency (MHz)	Mode	UL RB Allocation	UL RB Offset	MPR	Average power (dBm)
26	3	26805	825.5	QPSK	1	0	0	22.16
					1	7	0	22.06
					1	14	0	21.97
					8	0	1	21.27
					8	4	1	21.10
					8	7	1	21.15
				16QAM	15	0	1	21.22
					1	0	1	21.34
					1	7	1	21.30
					1	14	1	21.04
					8	0	2	20.17
					8	4	2	20.20
					8	7	2	20.00
					15	0	2	20.31
					26915	836.5	QPSK	1
		1	7	0				21.97
		1	14	0				21.88
		8	0	1				21.15
		8	4	1				21.01
		8	7	1				21.06
		16QAM	15	0			1	21.10
			1	0			1	21.22
			1	7			1	21.18
			1	14			1	20.95
			8	0			2	20.05
			8	4			2	20.11
			8	7			2	19.91
			15	0			2	21.30
			27025	847.5			QPSK	1
		1			7	0		22.02
1	14	0			21.98			
8	0	1			21.19			
8	4	1			21.06			
8	7	1			21.16			
16QAM	15	0			1	21.14		
	1	0			1	21.26		
	1	7			1	21.22		
	1	14			1	21.05		
	8	0			2	20.09		
	8	4			2	20.16		
	8	7			2	20.01		
	15	0			2	21.10		

Band	BW (MHz)	Channel	Frequency (MHz)	Mode	UL RB Allocation	UL RB Offset	MPR	Average power (dBm)
26	5	26815	826.5	QPSK	1	0	0	22.21
					1	12	0	22.11
					1	24	0	22.02
					12	0	1	21.32
					12	6	1	21.15
					12	11	1	21.20
					25	0	1	21.27
				16QAM	1	0	1	21.39
					1	12	1	21.35
					1	24	1	21.09
					12	0	2	20.22
					12	6	2	20.25
					12	11	2	20.05
					25	0	2	20.36
		26915	836.5	QPSK	1	0	0	22.09
					1	12	0	22.02
					1	24	0	21.93
					12	0	1	21.20
					12	6	1	21.06
					12	11	1	21.11
					25	0	1	21.15
				16QAM	1	0	1	21.27
					1	12	1	21.23
					1	24	1	21.00
					12	0	2	20.10
					12	6	2	20.16
					12	11	2	19.96
					25	0	2	20.24
		27015	846.5	QPSK	1	0	0	22.13
					1	12	0	22.07
1	24				0	22.03		
12	0				1	21.24		
12	6				1	21.11		
12	11				1	21.21		
25	0				1	21.19		
16QAM	1			0	1	21.31		
	1			12	1	21.27		
	1			24	1	21.10		
	12			0	2	20.14		
	12			6	2	20.21		
	12			11	2	20.06		
	25			0	2	20.28		

Band	BW (MHz)	Channel	Frequency (MHz)	Mode	UL RB Allocation	UL RB Offset	MPR	Average power (dBm)		
26	10	26840	829.0	QPSK	1	0	0	22.26		
					1	24	0	22.16		
					1	49	0	22.07		
					25	0	1	21.37		
					25	12	1	21.20		
					25	24	1	21.25		
				16QAM	50	0	1	21.32		
					1	0	1	21.44		
					1	24	1	21.40		
					1	49	1	21.14		
					25	0	2	20.27		
					25	12	2	20.30		
		26915	836.5	QPSK	836.5	QPSK	25	24	2	20.10
							50	0	2	20.41
							1	0	0	22.14
							1	24	0	22.07
							1	49	0	21.98
							25	0	1	21.25
				16QAM	25	12	1	21.11		
					25	24	1	21.16		
					50	0	1	21.20		
					1	0	1	21.32		
					1	24	1	21.28		
					1	49	1	21.05		
		26990	844.0	QPSK	844.0	QPSK	25	0	2	20.27
							25	12	2	20.30
							25	24	2	20.10
							50	0	2	20.41
							1	0	0	22.18
							1	24	0	22.12
16QAM	1			49	0	22.08				
	25			0	1	21.29				
	25			12	1	21.16				
	25			24	1	21.26				
	50			0	1	21.24				
	1			0	1	21.36				
16QAM	1	24	1	21.32						
	1	49	1	21.15						
	25	0	2	20.19						
	25	12	2	20.26						
	25	24	2	20.11						
	50	0	2	20.33						

Band	BW (MHz)	Channel	Frequency (MHz)	Mode	UL RB Allocation	UL RB Offset	MPR	Average power (dBm)
26	15	26865	831.5	QPSK	1	0	0	22.31
					1	37	0	22.21
					1	74	0	22.12
					36	0	1	21.42
					36	18	1	21.25
					36	37	1	21.30
					75	0	1	21.37
				16QAM	1	0	1	21.49
					1	37	1	21.45
					1	74	1	21.19
					36	0	2	20.32
					36	18	2	20.35
					36	37	2	20.15
					75	0	2	20.46
		26915	836.5	QPSK	1	0	0	22.19
					1	37	0	22.12
					1	74	0	22.03
					36	0	1	21.30
					36	18	1	21.16
					36	37	1	21.21
					75	0	1	21.25
				16QAM	1	0	1	21.37
					1	37	1	21.33
					1	74	1	21.10
					36	0	2	20.20
					36	18	2	20.26
					36	37	2	20.06
					75	0	2	20.34
		26965	841.5	QPSK	1	0	0	22.23
					1	37	0	22.17
1	74				0	22.13		
36	0				1	21.34		
36	18				1	21.21		
36	37				1	21.31		
75	0				1	21.29		
16QAM	1			0	1	21.41		
	1			37	1	21.37		
	1			74	1	21.20		
	36			0	2	20.24		
	36			18	2	20.31		
	36			37	2	20.16		
	75			0	2	20.38		

End of Test Report