

## FCC Test Report

**Report No.:** RF160512C51-1

**FCC ID:** PTP-TU1601

**Test Model:** TU1601

**Received Date:** May 12, 2016

**Test Date:** May 27 ~ Jun. 15, 2016

**Issued Date:** Jun. 15, 2016

**Applicant:** Salutica Allied Solutions Sdn. Bhd

**Address:** 3 Jalan Zarib 6, Kawasan Perindustrian Zarib, 31500 Lahat Ipoh, Perak, Malaysia

**Issued By:** Bureau Veritas Consumer Products Services (H.K.) Ltd., Taoyuan Branch

**Lab Address:** No. 47-2, 14th Ling, Chia Pau Vil., Lin Kou Dist., New Taipei City, Taiwan, R.O.C.

**Test Location:** No. 19, Hwa Ya 2nd Rd., Wen Hwa Vil., Kwei Shan Dist., Taoyuan City 33383, TAIWAN (R.O.C.)



This report is for your exclusive use. Any copying or replication of this report to or for any other person or entity, or use of our name or trademark, is permitted only with our prior written permission. This report sets forth our findings solely with respect to the test samples identified herein. The results set forth in this report are not indicative or representative of the quality or characteristics of the lot from which a test sample was taken or any similar or identical product unless specifically and expressly noted. Our report includes all of the tests requested by you and the results thereof based upon the information that you provided to us. You have 60 days from date of issuance of this report to notify us of any material error or omission caused by our negligence, provided, however, that such notice shall be in writing and shall specifically address the issue you wish to raise. A failure to raise such issue within the prescribed time shall constitute your unqualified acceptance of the completeness of this report, the tests conducted and the correctness of the report contents. Unless specifically mentioned, the uncertainty of measurement has been explicitly taken into account to declare the compliance or non-compliance to the specification. The report must not be used by the client to claim product certification, approval, or endorsement by TAF or any government agencies.

## Table of Contents

<b>Release Control Record</b> .....	<b>3</b>
<b>1 Certificate of Conformity</b> .....	<b>4</b>
<b>2 Summary of Test Results</b> .....	<b>5</b>
2.1 Measurement Uncertainty.....	5
2.2 Modification Record.....	5
<b>3 General Information</b> .....	<b>6</b>
3.1 General Description of EUT.....	6
3.2 Description of Test Modes.....	6
3.2.1 Test Mode Applicability and Tested Channel Deta.....	7
3.3 Description of Support Units.....	9
3.3.1 Configuration of System under Test.....	9
3.4 General Description of Applied Standards.....	9
<b>4 Test Types and Results</b> .....	<b>10</b>
4.1 Radiated Emission Measurement.....	10
4.1.1 Limits of Radiated Emission Measurement.....	10
4.1.2 Test Instruments.....	11
4.1.3 Test Procedures.....	12
4.1.4 Deviation from Test Standard.....	12
4.1.5 Test Set Up.....	13
4.1.6 EUT Operating Conditions.....	13
4.1.7 Test Results.....	14
4.2 Frequency Stability.....	24
4.2.1 Limits of Frequency Stability Measurement.....	24
4.2.2 Test Setup.....	24
4.2.3 Test Instruments.....	24
4.2.4 Test Procedure.....	24
4.2.5 Deviation from Test Standard.....	24
4.2.6 EUT Operating Conditions.....	24
4.2.7 Test Result.....	25
4.3 20dB bandwidth.....	27
4.3.1 Limits of 20dB Bandwidth Measurement.....	27
4.3.2 Test Setup.....	27
4.3.3 Test Instruments.....	27
4.3.4 Test Procedures.....	27
4.3.5 Deviation from Test Standard.....	27
4.3.6 EUT Operating Conditions.....	27
4.3.7 Test Results.....	28
<b>5 Pictures of Test Arrangements</b> .....	<b>29</b>
<b>Appendix – Information on the Testing Laboratories</b> .....	<b>30</b>

### Release Control Record

Issue No.	Description	Date Issued
RF160512C51-1	Original release	Jun. 15, 2016

## 1 Certificate of Conformity

**Product:** In Car and Repeater

**Brand:** FOBO Ultra

**Test Model:** TU1601

**Sample Status:** Engineering sample

**Applicant:** Salutica Allied Solutions Sdn. Bhd

**Test Date:** May 27 ~ Jun. 15, 2016

**Standards:** 47 CFR FCC Part 15, Subpart C (Section 15.225)  
47 CFR FCC Part 15, Subpart C (Section 15.215)  
ANSI C63.10:2013

The above equipment has been tested by **Bureau Veritas Consumer Products Services (H.K.) Ltd., Taoyuan Branch**, and found compliance with the requirement of the above standards. The test record, data evaluation & Equipment Under Test (EUT) configurations represented herein are true and accurate accounts of the measurements of the sample's EMC characteristics under the conditions specified in this report.

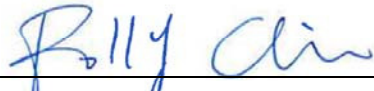
**Prepared by :**  , **Date:** Jun. 15, 2016  
Polly Chien / Specialist

**Approved by :**  , **Date:** Jun. 15, 2016  
Ken Liu / Senior Manager

## 2 Summary of Test Results

47 CFR FCC Part 15, Subpart C (Section 15.225, 15.215)			
FCC Clause	Test Item	Result	Remarks
15.207	Conducted emission test	Pass	Meet the requirement of limit. Minimum passing margin is -3.46dB at 13.56000MHz.
15.225 (a)	The field strength of any emissions within the band 13.553-13.567 MHz	Pass	Meet the requirement of limit. Minimum passing margin is -69.78dB at 13.56MHz.
15.225 (b)	The field strength of any emissions within the bands 13.410-13.553 MHz and 13.567-13.710 MHz	Pass	Meet the requirement of limit.
15.225 (c)	The field strength of any emissions within the bands 13.110-13.410 MHz and 13.710-14.010 MHz	Pass	Meet the requirement of limit.
15.225 (d)	The field strength of any emissions appearing outside of the 13.110-14.010 MHz band	Pass	Meet the requirement of limit. Minimum passing margin is -5.7dB at 78.51MHz.
15.225 (e)	The frequency tolerance	Pass	Meet the requirement of limit.
15.215 (c)	20dB Bandwidth	Pass	Meet the requirement of limit.

### 2.1 Measurement Uncertainty

Where relevant, the following measurement uncertainty levels have been estimated for tests performed on the EUT as specified in CISPR 16-4-2:

Measurement	Frequency	Expanded Uncertainty (k=2) ( $\pm$ )
Conducted Emissions at mains ports	150kHz ~ 30MHz	2.44 dB
	30MHz ~ 200MHz	3.59 dB
Radiated Emissions up to 1 GHz	200MHz ~1000MHz	3.60 dB

### 2.2 Modification Record

There were no modifications required for compliance.

### 3 General Information

#### 3.1 General Description of EUT

Product	In Car and Repeater
Brand	FOBO Ultra
Test Model	TU1601
Status of EUT	Engineering sample
Power Supply Rating	7.5Vdc (Battery: 1.5Vdc x 5) 24Vdc
Modulation Type	ASK
Operating Frequency	13.56MHz
Antenna Type	Loop antenna
Accessory Device	Battery
Data Cable Supplied	NA

Note:

1. The EUT uses following battery.

Battery	
Model	GP15AUP
Rating	1.5Vdc, 1.5A

2. The above EUT information is declared by manufacturer and for more detailed features description, please refer to the manufacturer's specifications or User's Manual.

#### 3.2 Description of Test Modes

1 channel is provided to this EUT

Channel	FREQ. (MHz)
1	13.56

### 3.2.1 Test Mode Applicability and Tested Channel Data

EUT CONFIGURE MODE	APPLICABLE TO				DESCRIPTION
	RE	PLC	FS	EB	
A	√	-	-	√	EUT power from battery
B	√	√	√	-	EUT power from DC power supply

Where **RE:** Radiated Emission **PLC:** Power Line Conducted Emission  
**FS:** Frequency Stability **EB:** 20dB Bandwidth measurement

**Note:**

1. The EUT had been pre-tested on the positioned of each 3 axis. The worst case was found when positioned on **Z-plane**.
2. "-": Means no effect.

**Radiated Emission Test:**

- Pre-Scan has been conducted to determine the worst-case mode from all possible combinations between available modulations, data rates and antenna ports (if EUT with antenna diversity architecture).
- Following channel(s) was (were) selected for the final test as listed below.

EUT CONFIGUURE MODE	AVAILABLE CHANNEL	TESTED CHANNEL	MODULATION TYPE
A, B	1	1	ASK

**Power Line Conducted Emission Test:**

- Pre-Scan has been conducted to determine the worst-case mode from all possible combinations between available modulations, data rates and antenna ports (if EUT with antenna diversity architecture).
- Following channel(s) was (were) selected for the final test as listed below.

EUT CONFIGUURE MODE	AVAILABLE CHANNEL	TESTED CHANNEL	MODULATION TYPE
B	1	1	ASK

**Frequency Stability:**

- Pre-Scan has been conducted to determine the worst-case mode from all possible combinations between available modulations, data rates and antenna ports (if EUT with antenna diversity architecture).
- Following channel(s) was (were) selected for the final test as listed below.

EUT CONFIGUURE MODE	AVAILABLE CHANNEL	TESTED CHANNEL	MODULATION TYPE
B	1	1	ASK

**20dB Bandwidth:**

- Pre-Scan has been conducted to determine the worst-case mode from all possible combinations between available modulations, data rates and antenna ports (if EUT with antenna diversity architecture).
- Following channel(s) was (were) selected for the final test as listed below.

EUT CONFIGUURE MODE	AVAILABLE CHANNEL	TESTED CHANNEL	MODULATION TYPE
A	1	1	ASK

**Test Condition:**

APPLICABLE TO	ENVIRONMENTAL CONDITIONS	INPUT POWER	TESTED BY
RE	16deg. C, 70%RH,	24Vdc 7.5Vdc	Nick Hsu,
PLC	16deg. C, 70%RH	24Vdc	Nick Hsu
FS	16deg. C, 70%RH	24Vdc	Nick Hsu
BW	16deg. C, 70%RH	7.5Vdc	Nick Hsu

### 3.3 Description of Support Units

The EUT has been tested as an independent unit together with other necessary accessories or support units. The following support units or accessories were used to form a representative test configuration during the tests.

ID	Product	Brand	Model No.	Serial No.	FCC ID	Remarks
A.	DC Power Supply	TOPWARD	6303D	802236	NA	-

Note: All power cords of the above support units are non-shielded (1.8m).

ID	Descriptions	Qty.	Length (m)	Shielding (Yes/No)	Cores (Qty.)	Remarks
1.	Power cable	1	2	N	0	-

#### 3.3.1 Configuration of System under Test

Test mode A

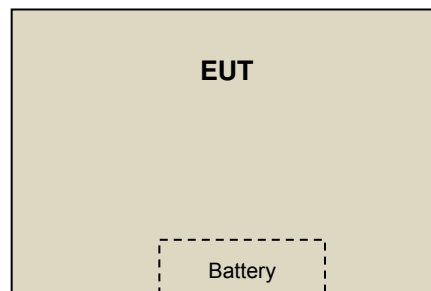

Test mode B

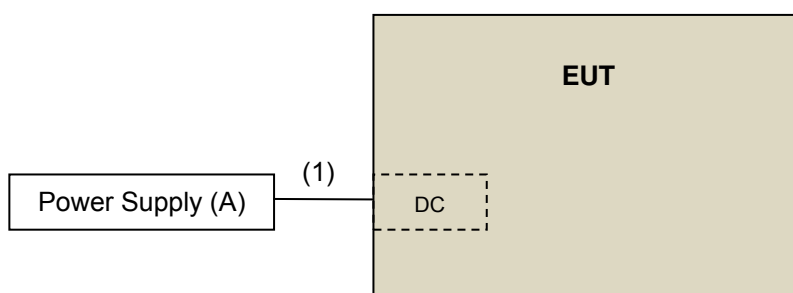

### 3.4 General Description of Applied Standards

The EUT is a RF Product. According to the specifications of the manufacturer, it must comply with the requirements of the following standards:

**FCC Part 15, Subpart C (15.225)**

**FCC Part 15, Subpart C (15.215)**

ANSI C63.10-2013

All test items have been performed and recorded as per the above standards.

Note: The EUT has been verified to comply with the requirements of FCC Part 15, Subpart B, Class B (DoC). The test report has been issued separately.

## 4 Test Types and Results

### 4.1 Radiated Emission Measurement

#### 4.1.1 Limits of Radiated Emission Measurement

The field strength of any emissions within the band 13.553-13.567 MHz shall not exceed 15,848 microvolts/meter at 30 meters.

The field strength of any emissions appearing outside of the 13.110-14.010 MHz band shall not exceed the general radiated emission limits in § 15.209.

Frequencies (MHz)	Field Strength (microvolts/meter)	Measurement Distance (meters)
0.009 ~ 0.490	2400/F(kHz)	300
0.490 ~ 1.705	24000/F(kHz)	30
1.705 ~ 30.0	30	30
30 ~ 88	100	3
88 ~ 216	150	3
216 ~ 960	200	3
Above 960	500	3

**Note:**

1. The lower limit shall apply at the transition frequencies.
2. Emission level (dBuV/m) = 20 log Emission level (uV/m).
3. For frequencies above 1000MHz, the field strength limits are based on average detector, however, the peak field strength of any emission shall not exceed the maximum permitted average limits, specified above by more than 20dB under any condition of modulation.

#### 4.1.2 Test Instruments

Description & Manufacturer	Model No.	Serial No.	Cal. Date	Cal. Due
Test Receiver ROHDE & SCHWARZ	ESCI	100424	Oct. 12, 2015	Oct. 11, 2016
Spectrum Analyzer ROHDE & SCHWARZ	FSP40	100040	Jul. 08, 2015	Jul. 07, 2016
BILOG Antenna SCHWARZBECK	VULB9168	9168-155	Jan. 07, 2016	Jan. 06, 2017
HORN Antenna SCHWARZBECK	BBHA 9120D	9120D-1170	Jan. 08, 2016	Jan. 07, 2017
HORN Antenna SCHWARZBECK	BBHA 9170	BBHA9170241	Jan. 18, 2016	Jan. 17, 2017
Loop Antenna	EM-6879	269	Jul. 31, 2015	Jul. 30, 2016
Preamplifier Agilent	8449B	3008A01960	Aug. 09, 2015	Aug. 08, 2016
Preamplifier Agilent	8447D	2944A10631	Aug. 09, 2015	Aug. 08, 2016
RF signal cable HUBER+SUHNER	SUCOFLEX 104	Cable-CH4-02(295012+ 309220)	Aug. 09, 2015	Aug. 08, 2016
RF signal cable HUBER+SUHNER	SUCOFLEX 104	Cable-CH4-03(250724)	Aug. 09, 2015	Aug. 08, 2016
Software BV ADT	ADT_Radiated_ V7.6.15.9.4	NA	NA	NA
Antenna Tower inn-co GmbH	MA 4000	010303	NA	NA
Antenna Tower Controller BV ADT	AT100	AT93021703	NA	NA
Turn Table BV ADT	TT100	TT93021703	NA	NA
Turn Table Controller BV ADT	SC100.	SC93021703	NA	NA
High Speed Peak Power Meter	ML2495A	0824011	Jul. 09, 2015	Jul. 08, 2016
Power Sensor	MA2411B	0738171	Jul. 09, 2015	Jul. 08, 2016

- Note:
1. The calibration interval of the above test instruments is 12 months and the calibrations are traceable to NML/ROC and NIST/USA.
  2. The test was performed in HwaYa Chamber 4.
  3. The horn antenna and preamplifier (model: 8449B) are used only for the measurement of emission frequency above 1GHz if tested.
  4. The FCC Site Registration No. is 460141.
  5. The IC Site Registration No. is IC7450F-4.

#### 4.1.3 Test Procedures

- a. The EUT was placed on the top of a rotating table 0.8 meters above the ground at a 3 meters semi-anechoic chamber. The table was rotated 360 degrees to determine the position of the highest radiation.
- b. The EUT was set 3 meters away from the interference-receiving antenna, which was mounted on the top of a variable-height antenna tower.
- c. Height of receiving antenna is varied from one meter to four meters above the ground to determine the maximum value of the field strength. Both horizontal and vertical polarizations of the antenna are set to make the measurement.
- d. For each suspected emission, the EUT was arranged to its worst case and then the antenna was tuned to heights from 1 meter to 4 meters and the rotatable table was turned from 0 degrees to 360 degrees to find the maximum reading.
- e. The test-receiver system was set to Peak Detect Function and Specified Bandwidth with Maximum Hold Mode.
- f. If the emission level of the EUT in peak mode was lower than the limit specified, then testing could be stopped and the peak values of the EUT would be reported. Otherwise the emissions would be re-tested one by one using peak, quasi-peak or average method as specified and then reported in a data sheet.

**Note:**

1. The resolution bandwidth and video bandwidth of test receiver/spectrum analyzer is 120kHz for Quasi-peak detection at frequency below 1GHz.
2. The resolution bandwidth of test receiver/spectrum analyzer is 1MHz and video bandwidth is 3MHz for Peak detection at frequency above 1GHz.
3. The resolution bandwidth of test receiver/spectrum analyzer is 1MHz and the video bandwidth is  $\geq 1/T$  (Duty cycle < 98%) or 10Hz (Duty cycle > 98%) for Average detection (AV) at frequency above 1GHz.
4. All modes of operation were investigated and the worst-case emissions are reported.

#### 4.1.4 Deviation from Test Standard

No deviation.

#### 4.1.5 Test Set Up

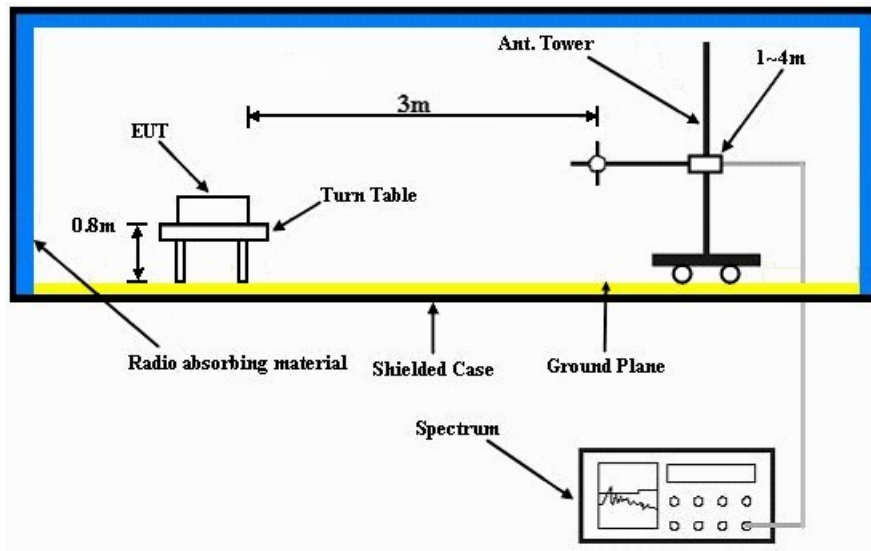

For the actual test configuration, please refer to the attached file (Test Setup Photo).

#### 4.1.6 EUT Operating Conditions

Set the EUT under transmission condition continuously at specific channel frequency.

#### 4.1.7 Test Results

EUT Test Condition		Measurement Detail	
Channel	Channel 1	Frequency Range	13.553 ~ 13.567MHz
Input Power	7.5Vdc	Detector Function	Quasi-Peak
Environmental Conditions	16deg. C, 70%RH	Tested By	Nick Hsu

Antenna Polarity & Test Distance: Loop Antenna Open At 3m								
No.	Freq. (MHz)	Emission Level (dBuV/m)	Limit (dBuV/m)	Margin (dB)	Antenna Height (m)	Table Angle (Degree)	Raw Value (dBuV)	Correction Factor (dB/m)
1	13.56	54.22	124.00	-69.78	1.00	353	46.40	7.80

- Remarks:**
1. Emission level(dBuV/m)=Raw Value(dBuV) + Correction Factor(dB/m)
  2. Correction Factor(dB/m) = Antenna Factor (dB/m) + Cable Factor (dB) – Pre-Amplifier Factor(dB)
  3. The other emission levels were very low against the limit.
  4. Margin value = Emission level – Limit value.
  5. Above limits have been translated by the formula

The measured field strength was extrapolated to distance 30 meters, using the formula that the limit of field strength varies as the inverse distance square (40dB per decade of distance)

Example:

$$\begin{aligned}
 13.56\text{MHz} &= 15848\mu\text{V/m} && 30\text{m} \\
 &= 84\text{dBuV/m} && 30\text{m} \\
 &= 84+20\log(30/3)^2 && 3\text{m} \\
 &= 124\text{dBuV/m}
 \end{aligned}$$

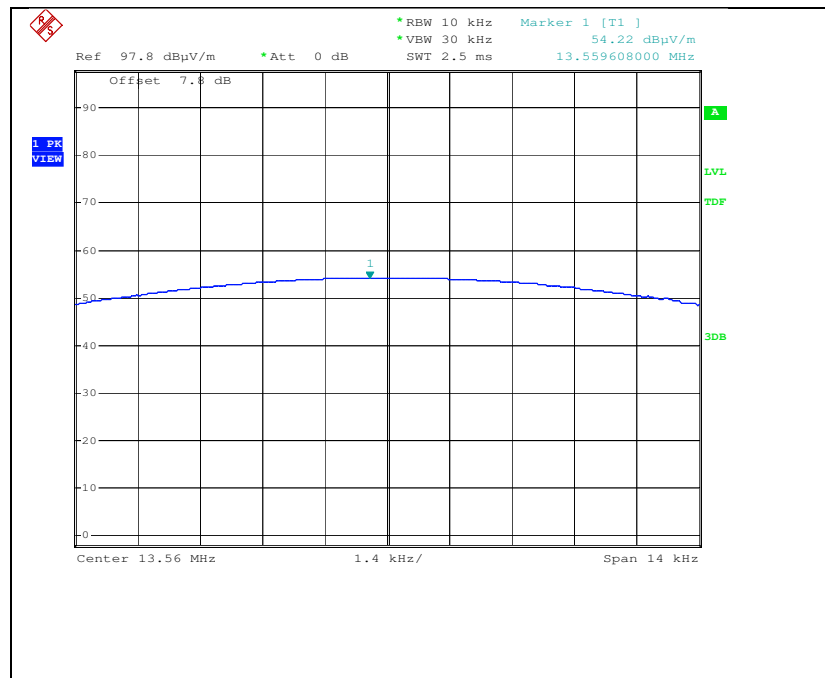

EUT Test Condition		Measurement Detail	
Channel	Channel 1	Frequency Range	13.553 ~ 13.567MHz
Input Power	7.5Vdc	Detector Function	Quasi-Peak
Environmental Conditions	16deg. C, 70%RH	Tested By	Nick Hsu

Antenna Polarity & Test Distance: Loop Antenna Close At 3m								
No.	Freq. (MHz)	Emission Level (dBuV/m)	Limit (dBuV/m)	Margin (dB)	Antenna Height (m)	Table Angle (Degree)	Raw Value (dBuV)	Correction Factor (dB/m)
1	13.56	51.13	124.00	-72.87	1.00	83	43.30	7.80

- Remarks:**
1. Emission level(dBuV/m)=Raw Value(dBuV) + Correction Factor(dB/m)
  2. Correction Factor(dB/m) = Antenna Factor (dB/m) + Cable Factor (dB) – Pre-Amplifier Factor(dB)
  3. The other emission levels were very low against the limit.
  4. Margin value = Emission level – Limit value.
  5. Above limits have been translated by the formula

The measured field strength was extrapolated to distance 30 meters, using the formula that the limit of field strength varies as the inverse distance square (40dB per decade of distance)

Example:

$$\begin{aligned}
 13.56\text{MHz} &= 15848\mu\text{V/m} && 30\text{m} \\
 &= 84\text{dBuV/m} && 30\text{m} \\
 &= 84+20\log(30/3)^2 && 3\text{m} \\
 &= 124\text{dBuV/m}
 \end{aligned}$$

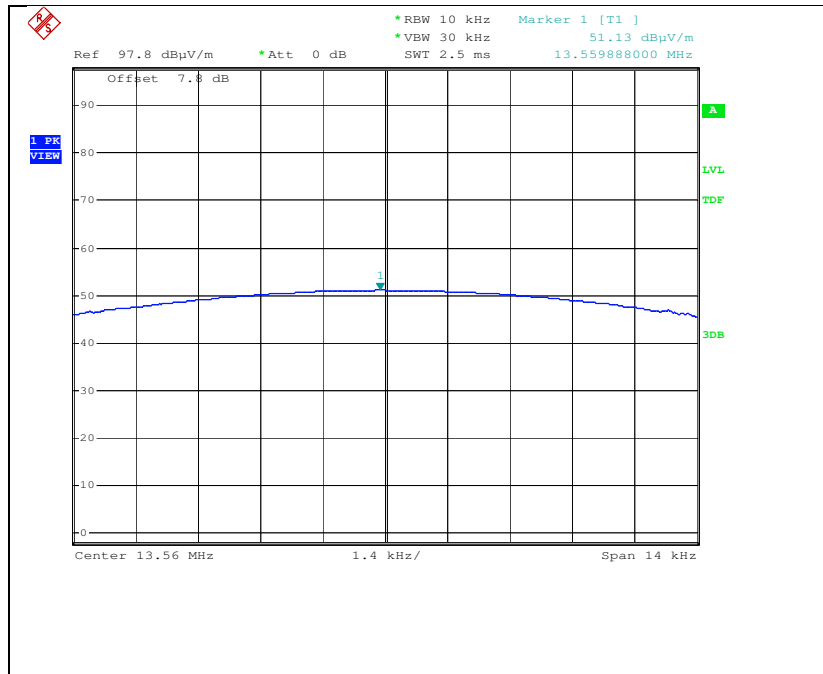

EUT Test Condition		Measurement Detail	
Channel	Channel 1	Frequency Range	Below 30MHz
Input Power	7.5Vdc	Detector Function	Quasi-Peak
Environmental Conditions	16deg. C, 70%RH	Tested By	Nick Hsu

Antenna Polarity & Test Distance: Loop Antenna Open At 3m								
No.	Freq. (MHz)	Emission Level (dBuV/m)	Limit (dBuV/m)	Margin (dB)	Antenna Height (m)	Table Angle (Degree)	Raw Value (dBuV)	Correction Factor (dB/m)
1	27.12	23.90	69.50	-45.60	1.00 V	185	17.20	6.70

**Remarks:**

1. Emission Level(dBuV/m) = Raw Value(dBuV) + Correction Factor(dB/m)
2. Correction Factor(dB/m) = Antenna Factor(dB/m) + Cable Factor(dB)  
– Pre-Amplifier Factor (dB)
3. The other emission levels were very low against the limit.
4. Margin value = Emission Level – Limit value

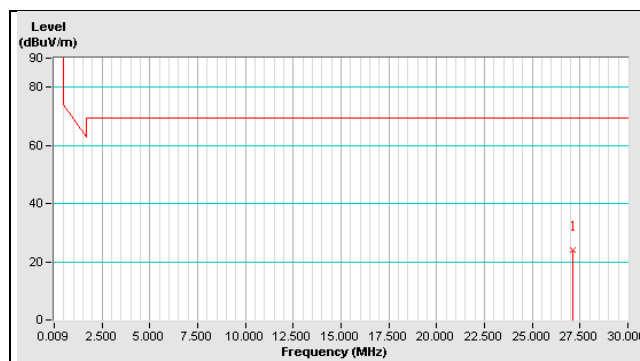

EUT Test Condition		Measurement Detail	
Channel	Channel 1	Frequency Range	Below 30MHz
Input Power	7.5Vdc	Detector Function	Quasi-Peak
Environmental Conditions	16deg. C, 70%RH	Tested By	Nick Hsu

Antenna Polarity & Test Distance: Loop Antenna Close At 3m								
No.	Freq. (MHz)	Emission Level (dBuV/m)	Limit (dBuV/m)	Margin (dB)	Antenna Height (m)	Table Angle (Degree)	Raw Value (dBuV)	Correction Factor (dB/m)
1	27.12	25.50	69.50	-44.00	1.00 V	197	18.80	6.70

**Remarks:**

1. Emission Level(dBuV/m) = Raw Value(dBuV) + Correction Factor(dB/m)
2. Correction Factor(dB/m) = Antenna Factor(dB/m) + Cable Factor(dB)  
– Pre-Amplifier Factor (dB)
3. The other emission levels were very low against the limit.
4. Margin value = Emission Level – Limit value

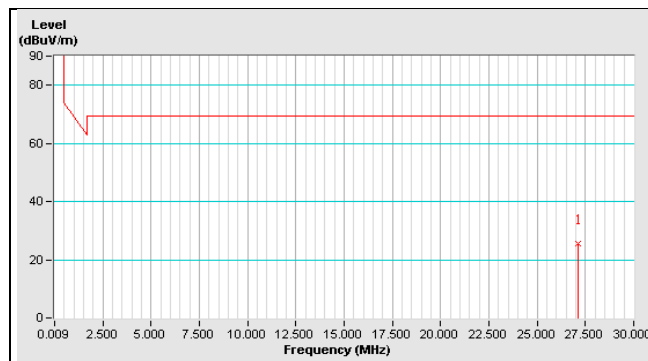

EUT Test Condition		Measurement Detail	
Channel	Channel 1	Frequency Range	Below 1000MHz
Input Power	7.5Vdc	Detector Function	Quasi-Peak
Environmental Conditions	16deg. C, 70%RH	Tested By	Nick Hsu
Test Mode	A		

Antenna Polarity & Test Distance: Horizontal At 3m								
No.	Freq. (MHz)	Emission Level (dBuV/m)	Limit (dBuV/m)	Margin (dB)	Antenna Height (m)	Table Angle (Degree)	Raw Value (dBuV)	Correction Factor (dB/m)
1	30.00	21.8 QP	40.0	-18.2	1.01 H	340	38.00	-16.20
2	57.12	30.6 QP	40.0	-9.4	2.00 H	61	45.20	-14.60
3	62.95	23.2 QP	40.0	-16.8	1.01 H	282	38.30	-15.10
4	70.73	19.7 QP	40.0	-20.3	2.00 H	312	36.30	-16.60
5	84.34	19.7 QP	40.0	-20.3	2.00 H	231	39.10	-19.40
6	127.11	17.3 QP	43.5	-26.2	1.01 H	12	33.20	-15.90

Antenna Polarity & Test Distance: Vertical At 3m								
No.	Freq. (MHz)	Emission Level (dBuV/m)	Limit (dBuV/m)	Margin (dB)	Antenna Height (m)	Table Angle (Degree)	Raw Value (dBuV)	Correction Factor (dB/m)
1	30.00	26.9 QP	40.0	-13.1	1.49 V	154	43.10	-16.20
2	41.57	25.5 QP	40.0	-14.5	1.49 V	240	40.60	-15.10
3	57.12	26.1 QP	40.0	-13.9	1.00 V	246	40.70	-14.60
4	76.56	25.4 QP	40.0	-14.6	1.49 V	119	43.40	-18.00
5	132.95	20.4 QP	43.5	-23.1	1.49 V	13	35.70	-15.30
6	249.60	16.9 QP	46.0	-29.1	1.00 V	271	31.10	-14.20

**Remarks:**

1. Emission Level(dBuV/m) = Raw Value(dBuV) + Correction Factor(dB/m)
2. Correction Factor(dB/m) = Antenna Factor(dB/m) + Cable Factor(dB)  
– Pre-Amplifier Factor (dB)
3. The other emission levels were very low against the limit.
4. Margin value = Emission Level – Limit value

EUT Test Condition		Measurement Detail	
Channel	Channel 1	Frequency Range	Below 1000MHz
Input Power	24Vdc	Detector Function	Quasi-Peak
Environmental Conditions	16deg. C, 70%RH	Tested By	Nick Hsu
Test Mode	B		

Antenna Polarity & Test Distance: Horizontal At 3m								
No.	Freq. (MHz)	Emission Level (dBuV/m)	Limit (dBuV/m)	Margin (dB)	Antenna Height (m)	Table Angle (Degree)	Raw Value (dBuV)	Correction Factor (dB/m)
1	30.00	18.9 QP	40.0	-21.1	1.00 H	329	35.10	-16.20
2	57.12	29.9 QP	40.0	-10.1	2.00 H	36	44.50	-14.60
3	70.73	19.4 QP	40.0	-20.6	2.00 H	52	36.00	-16.60
4	84.34	18.7 QP	40.0	-21.3	2.00 H	52	38.10	-19.40
5	175.72	18.0 QP	43.5	-25.5	1.50 H	265	32.60	-14.60
6	257.38	21.1 QP	46.0	-24.9	1.00 H	87	35.20	-14.10

Antenna Polarity & Test Distance: Vertical At 3m								
No.	Freq. (MHz)	Emission Level (dBuV/m)	Limit (dBuV/m)	Margin (dB)	Antenna Height (m)	Table Angle (Degree)	Raw Value (dBuV)	Correction Factor (dB/m)
1	30.00	23.4 QP	40.0	-16.6	1.49 V	13	39.60	-16.20
2	57.12	25.4 QP	40.0	-14.6	1.00 V	162	40.00	-14.60
3	66.84	24.3 QP	40.0	-15.7	1.49 V	175	40.20	-15.90
<b>4</b>	<b>78.51</b>	<b>34.3 QP</b>	<b>40.0</b>	<b>-5.7</b>	<b>1.49 V</b>	<b>186</b>	<b>52.70</b>	<b>-18.40</b>
5	232.11	20.8 QP	46.0	-25.2	1.00 V	266	36.50	-15.70
6	364.32	29.9 QP	46.0	-16.1	1.49 V	150	40.80	-10.90

**Remarks:**

1. Emission Level(dBuV/m) = Raw Value(dBuV) + Correction Factor(dB/m)
2. Correction Factor(dB/m) = Antenna Factor(dB/m) + Cable Factor(dB)  
– Pre-Amplifier Factor (dB)
3. The other emission levels were very low against the limit.
4. Margin value = Emission Level – Limit value

## 4.2 Conducted Emission Measurement

### 4.2.1 Limits of Conducted Emission Measurement

Frequency (MHz)	Conducted Limit (dBuV)	
	Quasi-peak	Average
0.15 - 0.5	66 - 56	56 - 46
0.50 - 5.0	56	46
5.0 - 30.0	60	50

Note: 1. The lower limit shall apply at the transition frequencies.

2. The limit decreases in line with the logarithm of the frequency in the range of 0.15 to 0.50MHz.

### 4.2.2 Test Instruments

Description & Manufacturer	Model No.	Serial No.	Date Of Calibration	Due Date Of Calibration
Test Receiver ROHDE & SCHWARZ	ESCI	100424	Oct. 12, 2015	Oct. 11, 2016
RF signal cable (with 10dB PAD) Woken	5D-FB	Cable-cond2-01	Dec. 26, 2015	Dec. 25, 2016
LISN ROHDE & SCHWARZ (EUT)	ESH2-Z5	100100	Jan. 11, 2016	Jan. 10, 2017
LISN ROHDE & SCHWARZ (Peripheral)	ESH3-Z5	100312	Jul. 21, 2015	Jul. 20, 2016
Software ADT	BV ADT_Cond_ V7.3.7.3	NA	NA	NA

Note: 1. The calibration interval of the above test instruments is 12 months and the calibrations are traceable to NML/ROC and NIST/USA.

2. The test was performed in HwaYa Shielded Room 2.

3. The VCCI Site Registration No. is C-2047.

### 4.2.3 Test Procedures

- The EUT was placed 0.4 meters from the conducting wall of the shielded room with EUT being connected to the power mains through a line impedance stabilization network (LISN). Other support units were connected to the power mains through another LISN. The two LISNs provide 50 ohm/ 50uH of coupling impedance for the measuring instrument.
- Both lines of the power mains connected to the EUT were checked for maximum conducted interference.
- The frequency range from 150kHz to 30MHz was searched. Emission levels under (Limit - 20dB) was not recorded.

**NOTE:** The resolution bandwidth and video bandwidth of test receiver is 9kHz for quasi-peak detection (QP) and average detection (AV) at frequency 0.15MHz-30MHz.

#### 4.2.4 Deviation from Test Standard

No deviation.

#### 4.2.5 Test Setup

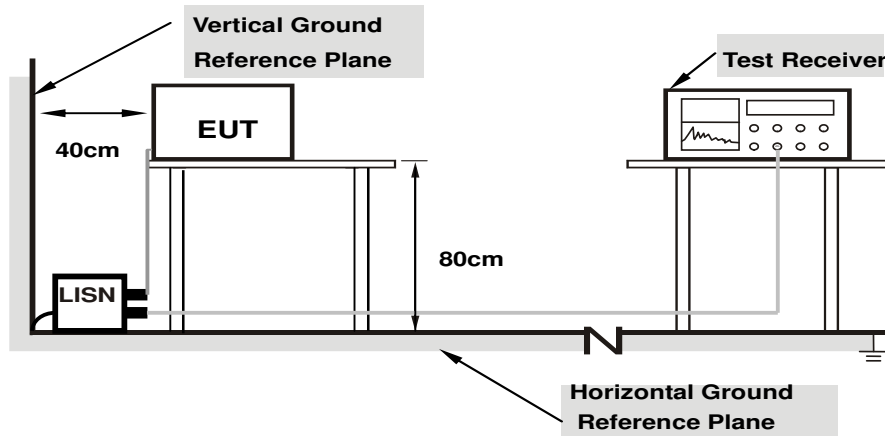

**Note: 1.Support units were connected to second LISN.**

For the actual test configuration, please refer to the attached file (Test Setup Photo).

#### 4.2.6 EUT Operating Conditions

Same as 4.1.6.

#### 4.2.7 Test Results

Phase	Line (L)	Detector Function	Quasi-Peak (QP) / Average (AV)
-------	----------	-------------------	--------------------------------

No	Freq. [MHz]	Corr. Factor (dB)	Reading Value		Emission Level		Limit		Margin	
			[dB (uV)]		[dB (uV)]		[dB (uV)]		(dB)	
			Q.P.	AV.	Q.P.	AV.	Q.P.	AV.	Q.P.	AV.
1	0.16562	10.13	19.54	16.18	29.67	26.31	65.18	55.18	-35.51	-28.87
2	0.43906	10.19	19.46	16.34	29.65	26.53	57.08	47.08	-27.43	-20.55
3	0.56406	10.20	17.82	16.04	28.02	26.24	56.00	46.00	-27.98	-19.76
4	1.46484	10.25	17.28	15.82	27.53	26.07	56.00	46.00	-28.47	-19.93
5	13.56000	10.52	34.76	30.52	45.28	41.04	60.00	50.00	-14.72	-8.96
6	27.12000	10.47	26.70	23.42	37.17	33.89	60.00	50.00	-22.83	-16.11

#### REMARKS:

1. Q.P. and AV. are abbreviations of quasi-peak and average individually.
2. The emission levels of other frequencies were very low against the limit.
3. Margin value = Emission level - Limit value
4. Correction factor = Insertion loss + Cable loss
5. Emission Level = Correction Factor + Reading Value.

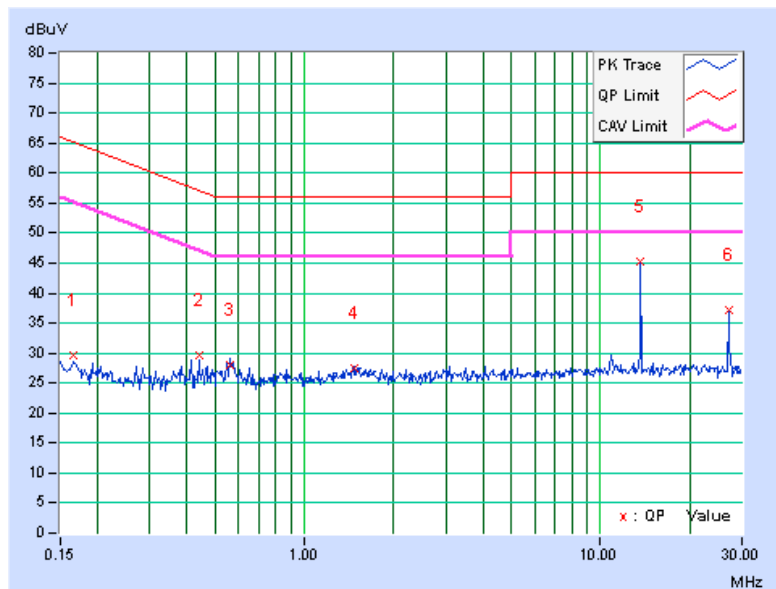

Phase	Neutral (N)	Detector Function	Quasi-Peak (QP) / Average (AV)
-------	-------------	-------------------	--------------------------------

No	Freq. [MHz]	Corr. Factor (dB)	Reading Value [dB (uV)]		Emission Level [dB (uV)]		Limit [dB (uV)]		Margin (dB)	
			Q.P.	AV.	Q.P.	AV.	Q.P.	AV.	Q.P.	AV.
			1	0.38047	10.19	18.62	16.20	28.81	26.39	58.27
2	0.44297	10.19	18.36	16.24	28.55	26.43	57.01	47.01	-28.46	-20.58
3	1.41016	10.25	17.20	15.76	27.45	26.01	56.00	46.00	-28.55	-19.99
4	2.43750	10.32	17.32	15.66	27.64	25.98	56.00	46.00	-28.36	-20.02
<b>5</b>	<b>13.56000</b>	<b>10.62</b>	<b>40.36</b>	<b>35.92</b>	<b>50.98</b>	<b>46.54</b>	<b>60.00</b>	<b>50.00</b>	<b>-9.02</b>	<b>-3.46</b>
6	27.12000	10.61	27.44	23.56	38.05	34.17	60.00	50.00	-21.95	-15.83

#### REMARKS:

1. Q.P. and AV. are abbreviations of quasi-peak and average individually.
2. The emission levels of other frequencies were very low against the limit.
3. Margin value = Emission level - Limit value
4. Correction factor = Insertion loss + Cable loss
5. Emission Level = Correction Factor + Reading Value.

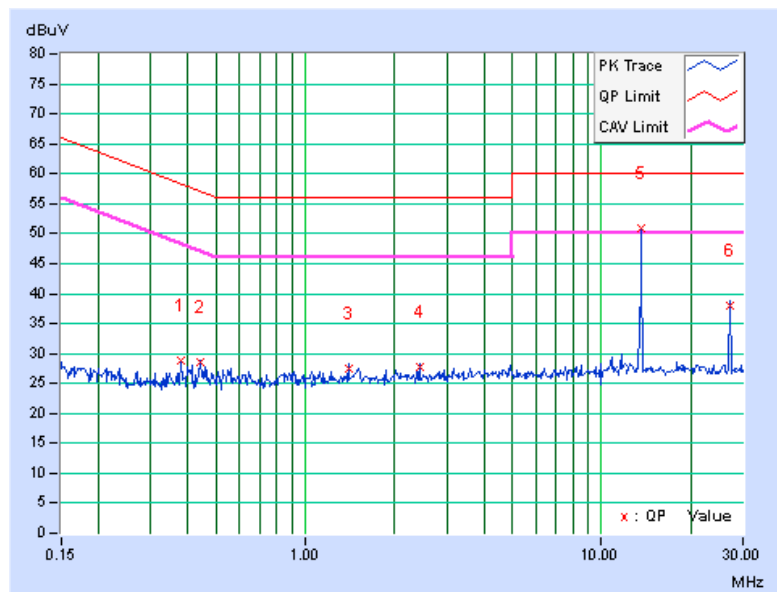

### 4.3 Frequency Stability

#### 4.3.1 Limits of Frequency Stability Measurement

The frequency tolerance of the carrier signal shall be maintained within  $\pm 0.01\%$  of the operating frequency over a temperature variation of  $-20$  degrees to  $50$  degrees C at normal supply voltage, and for a variation in the primary supply voltage from  $85\%$  to  $115\%$  of the rated supply voltage at a temperature of  $20$  degrees C.

#### 4.3.2 Test Setup

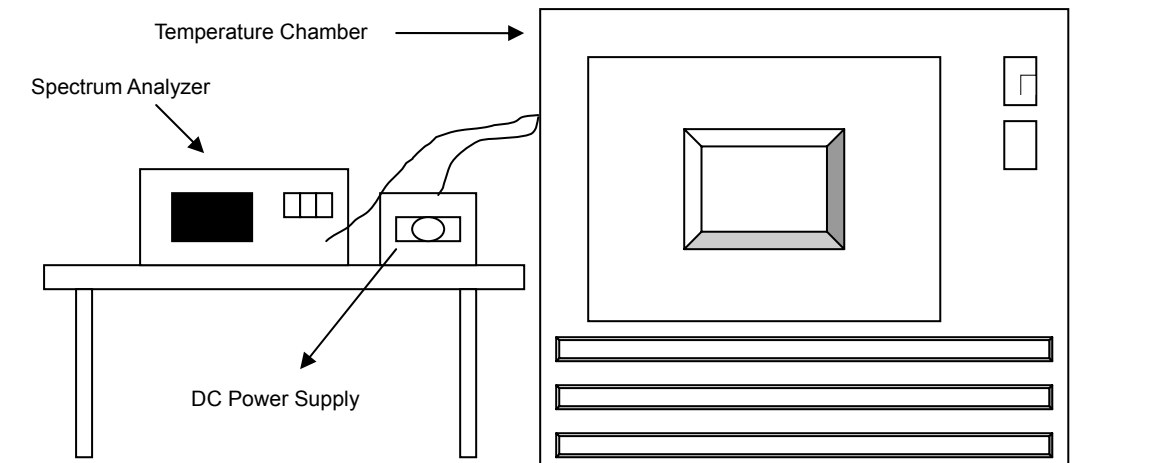

#### 4.3.3 Test Instruments

Refer to section 4.1.2 to get information of above instrument.

#### 4.3.4 Test Procedure

- The EUT was placed inside the environmental test chamber and powered by nominal DC voltage.
- Turned the EUT on and coupled its output to a spectrum analyzer.
- Turned the EUT off and set the chamber to the highest temperature specified.
- Allowed sufficient time (approximately 30 min) for the temperature of the chamber to stabilize then turned the EUT on and measured the operating frequency after 2, 5, and 10 minutes.
- Repeated step 2 and 3 with the temperature chamber set to the lowest temperature.
- The test chamber was allowed to stabilize at  $+20$  degree C for a minimum of 30 minutes. The supply voltage was then adjusted on the EUT from  $85\%$  to  $115\%$  and the frequency record.

#### 4.3.5 Deviation from Test Standard

No deviation.

#### 4.3.6 EUT Operating Conditions

Same as Item 4.1.6.

#### 4.3.7 Test Result

Frequency Stability Versus Temp.									
TEMP. (°C)	Power Supply (Vdc)	0 Minute		2 Minute		5 Minute		10 Minute	
		Measured Frequency	Frequency Drift	Measured Frequency	Frequency Drift	Measured Frequency	Frequency Drift	Measured Frequency	Frequency Drift
		(MHz)	%	(MHz)	%	(MHz)	%	(MHz)	%
80	27.6	13.559943	-0.00042	13.559956	-0.00032	13.559956	-0.00032	13.559954	-0.00034
	24	13.559942	-0.00043	13.559955	-0.00033	13.559954	-0.00034	13.559952	-0.00035
	20.4	13.559939	-0.00045	13.559955	-0.00033	13.559955	-0.00033	13.559953	-0.00035
70	27.6	13.559985	-0.00011	13.559989	-0.00008	13.559992	-0.00006	13.559987	-0.00010
	24	13.559983	-0.00013	13.55999	-0.00007	13.559996	-0.00003	13.559986	-0.00010
	20.4	13.559986	-0.00010	13.559989	-0.00008	13.559993	-0.00005	13.559986	-0.00010
60	27.6	13.56006	0.00044	13.560061	0.00045	13.560062	0.00046	13.560059	0.00044
	24	13.56006	0.00044	13.560064	0.00047	13.560061	0.00045	13.560061	0.00045
	20.4	13.560056	0.00041	13.56006	0.00044	13.560058	0.00043	13.560062	0.00046
50	27.6	13.559973	-0.00020	13.559959	-0.00030	13.559958	-0.00031	13.559958	-0.00031
	24	13.559977	-0.00017	13.559956	-0.00032	13.559959	-0.00030	13.55996	-0.00029
	20.4	13.559974	-0.00019	13.55996	-0.00029	13.559962	-0.00028	13.55996	-0.00029
40	27.6	13.55999	-0.00007	13.559998	-0.00001	13.560008	0.00006	13.560004	0.00003
	24	13.559987	-0.00010	13.559995	-0.00004	13.560006	0.00004	13.560006	0.00004
	20.4	13.55999	-0.00007	13.559994	-0.00004	13.560007	0.00005	13.560009	0.00007
30	27.6	13.560026	0.00019	13.560047	0.00035	13.560036	0.00027	13.56003	0.00022
	24	13.560023	0.00017	13.560047	0.00035	13.560036	0.00027	13.560028	0.00021
	20.4	13.560024	0.00018	13.560042	0.00031	13.56004	0.00029	13.560032	0.00024
20	27.6	13.559985	-0.00011	13.560004	0.00003	13.560005	0.00004	13.56001	0.00007
	24	13.559986	-0.00010	13.560004	0.00003	13.560005	0.00004	13.560013	0.00010
	20.4	13.559985	-0.00011	13.560004	0.00003	13.560009	0.00007	13.56001	0.00007
10	27.6	13.560041	0.00030	13.560045	0.00033	13.560059	0.00044	13.560036	0.00027
	24	13.560042	0.00031	13.56005	0.00037	13.560061	0.00045	13.56004	0.00029
	20.4	13.560042	0.00031	13.560046	0.00034	13.560062	0.00046	13.56004	0.00029
0	27.6	13.559953	-0.00035	13.559967	-0.00024	13.559946	-0.00040	13.559957	-0.00032
	24	13.559951	-0.00036	13.559968	-0.00024	13.559947	-0.00039	13.559956	-0.00032
	20.4	13.559948	-0.00038	13.559966	-0.00025	13.559948	-0.00038	13.559955	-0.00033
-10	27.6	13.560042	0.00031	13.560029	0.00021	13.560033	0.00024	13.560043	0.00032
	24	13.560042	0.00031	13.560031	0.00023	13.560031	0.00023	13.560042	0.00031
	20.4	13.560041	0.00030	13.560033	0.00024	13.560031	0.00023	13.560042	0.00031
-20	27.6	13.560001	0.00001	13.559996	-0.00003	13.560005	0.00004	13.560018	0.00013
	24	13.559997	-0.00002	13.559997	-0.00002	13.560007	0.00005	13.560015	0.00011
	20.4	13.559996	-0.00003	13.559997	-0.00002	13.56001	0.00007	13.560014	0.00010
-30	27.6	13.560001	0.00001	13.559996	-0.00003	13.560005	0.00004	13.560018	0.00013
	24	13.559997	-0.00002	13.559997	-0.00002	13.560007	0.00005	13.560015	0.00011
	20.4	13.559996	-0.00003	13.559997	-0.00002	13.56001	0.00007	13.560014	0.00010
-40	27.6	13.560001	0.00001	13.559996	-0.00003	13.560005	0.00004	13.560018	0.00013
	24	13.559997	-0.00002	13.559997	-0.00002	13.560007	0.00005	13.560015	0.00011
	20.4	13.559996	-0.00003	13.559997	-0.00002	13.56001	0.00007	13.560014	0.00010

## Frequency Stability Versus Voltage

TEMP. (°C)	Power Supply (Vdc)	0 Minute		2 Minute		5 Minute		10 Minute	
		Measured Frequency	Frequency Drift	Measured Frequency	Frequency Drift	Measured Frequency	Frequency Drift	Measured Frequency	Frequency Drift
		(MHz)	%	(MHz)	%	(MHz)	%	(MHz)	%
20	27.6	13.559985	-0.00011	13.560004	0.00003	13.560005	0.00004	13.56001	0.00007
	24	13.559986	-0.00010	13.560004	0.00003	13.560005	0.00004	13.560013	0.00010
	20.4	13.559985	-0.00011	13.560004	0.00003	13.560009	0.00007	13.56001	0.00007

#### **4.4 20dB bandwidth**

##### **4.4.1 Limits of 20dB Bandwidth Measurement**

The 20dB bandwidth shall be specified in operating frequency band.

##### **4.4.2 Test Setup**

Same as Item 4.1.5.

##### **4.4.3 Test Instruments**

Refer to section 4.1.2 to get information of above instrument.

##### **4.4.4 Test Procedures**

The bandwidth of the fundamental frequency was measured by spectrum analyzer with 1kHz RBW and 3kHz VBW. The 20dB bandwidth is defined as the total spectrum the power of which is higher than peak power minus 20dB.

##### **4.4.5 Deviation from Test Standard**

No deviation.

##### **4.4.6 EUT Operating Conditions**

Same as Item 4.1.6.

#### 4.4.7 Test Results

20dBc point (Low)	20dBc point (High)	Operating frequency band (MHz)	Pass / Fail
13.55744	13.56228	13.553~13.567	Pass

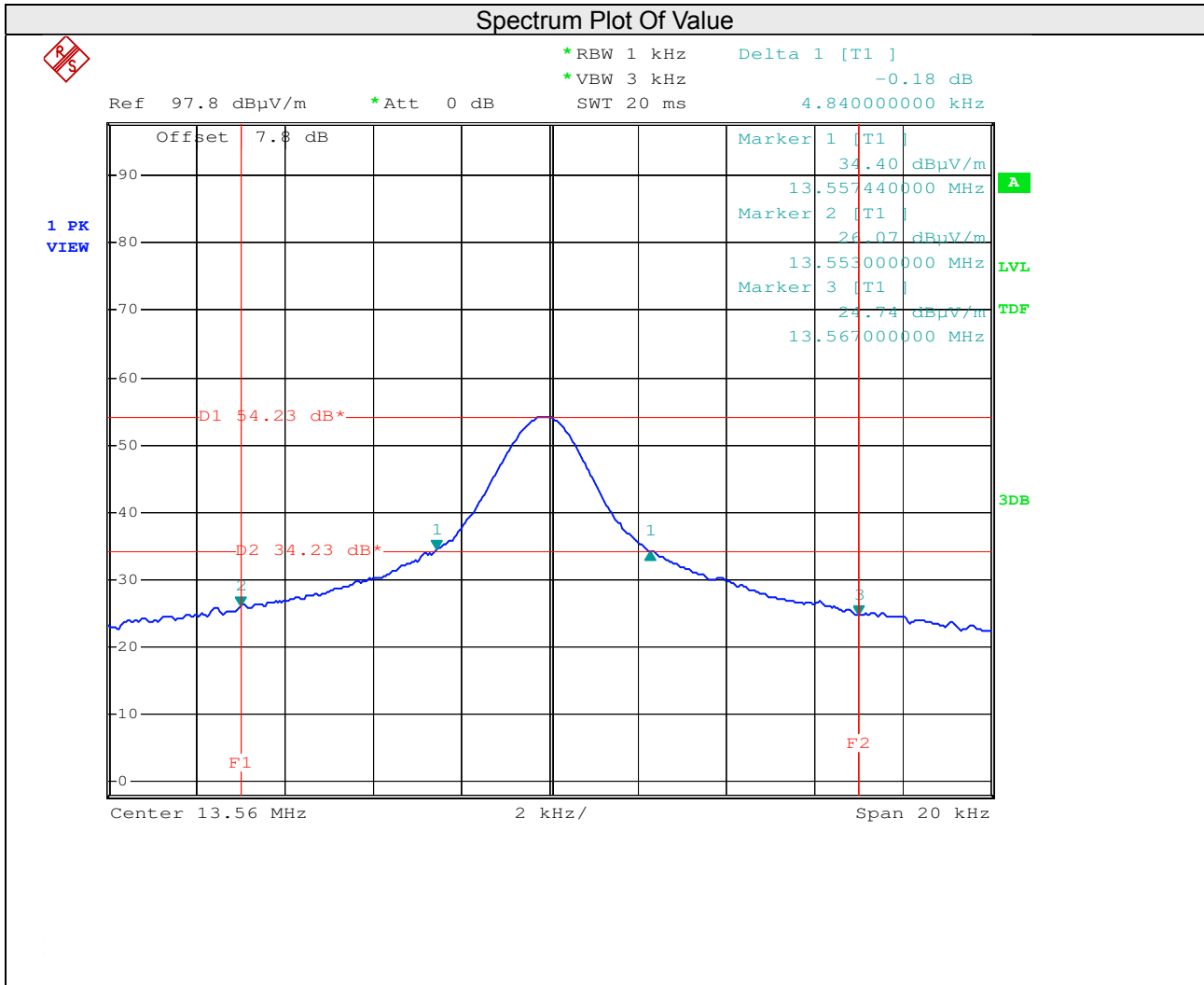

## 5 Pictures of Test Arrangements

Please refer to the attached file (Test Setup Photo).

## Appendix – Information on the Testing Laboratories

We, Bureau Veritas Consumer Products Services (H.K.) Ltd., Taoyuan Branch, were founded in 1988 to provide our best service in EMC, Radio, Telecom and Safety consultation. Our laboratories are accredited and approved according to ISO/IEC 17025.

If you have any comments, please feel free to contact us at the following:

**Linko EMC/RF Lab**

Tel: 886-2-26052180

Fax: 886-2-26051924

**Hsin Chu EMC/RF/Telecom Lab**

Tel: 886-3-6668565

Fax: 886-3-6668323

**Hwa Ya EMC/RF/Safety Lab**

Tel: 886-3-3183232

Fax: 886-3-3270892

**Email:** [service.adt@tw.bureauveritas.com](mailto:service.adt@tw.bureauveritas.com)

**Web Site:** [www.bureauveritas-adt.com](http://www.bureauveritas-adt.com)

The address and road map of all our labs can be found in our web site also.

--- END ---