

Change : "Made in Belgium" replaced by "Made in Portugal"

< Outline artwork version to use for printing on the product.  
3104-200-0731-2-110 (2007-07-18).eps

**PRINTING**

- Print on back side acc. to OUTLINE ARTWORK version on this drawing.
- color text : Black 80007
- color background : Bright Silver acc to 11126
- Color of rectangular area: No printing, it will be transparent.

**-ADHESIVE REQUIREMENTS**

- Rearside has to be self adhesive and protected with an easily removable layer
- Adhesive specification equivalent to Mactac-Macband B1148

**PRINTING REQUIREMENTS**

- Frontside : no printing
- Rearside : acc. to UAN-D1235 : App30 - Clim1

**GENERAL REQUIREMENTS**

- PCB and PCT free acc. to UAN-D1675
- Cadmium free acc. to UAN-D1597
- Product must be free from scratches and damages

**DELIVER**

- Approbation sticker to be delivered on sheet

ENVIRONMENTAL REQUIREMENT :  
NO BANNED SUBSTANCES ACC. TO UAW-0480/100

UN-D 28 TOLERANCES UNLESS OTHERWISE STATED TOLERANTIES TENZIJ ANDERS VERMELD DIMENSION MAAT +/-0.2 ANGLE HOEK		UN-D 603		TSU9200/00	
GENERAL ROUGHNESS ALGEMENE RUWHEID	UNIT EENH. mm	MATERIAL MATERIAAL	Polypropylene both sides high gloss <b>Thickness 0.125 mm.</b>	ITEM POST	ASSEMBLY NO. SAMENSTELLINGSNR.
SCALE SCHAAL	PROJ EUROP	TREATMENT BEHANDELING			QUANT. AANTAL
CLASS NO 6NE100	<b>Approbation sticker</b> <b>TSU9200/00/05</b>			1 2007-06-01 2 2007-07-18	
				3104 200 0731	
NAME NAAM Heysse Gert	SUPERS. VERV. 01	110	01	10	A4
PL	CHECK CONTR. DAT. 2007-06-01	Property of Eigendom van N.V. PHILIPS GLOEILAMPENFABRIEKEN EINDHOVEN - NEDERLAND			

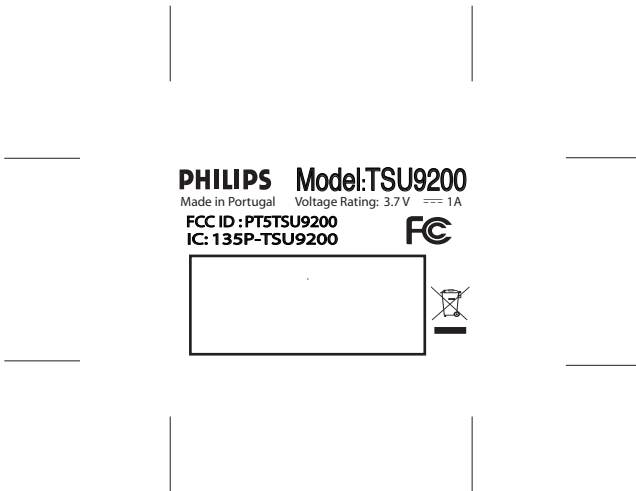
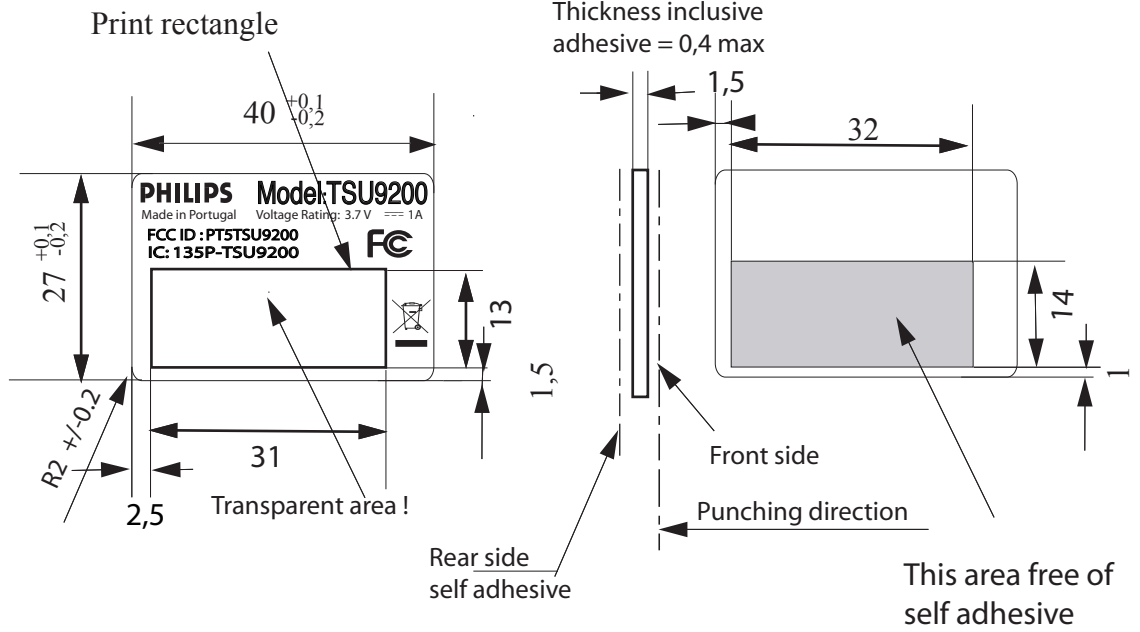

Change: "Made in Belgium" replaced by "Made in Portugal"

< Outline artwork version to use for printing on the product.  
3104-200-0732-1-110 (2007-06-01).eps

- PRINTING REQUIREMENTS**
- Frontside : no printing
  - Rearside : acc. to UAN-D1235 : App30 - Clim1
- GENERAL REQUIREMENTS**
- PCB and PCT free acc. to UAN-D1675
  - Cadmium free acc. to UAN-D1597
  - Product must be free from scratches and damages
- DELIVER**
- Approbation sticker to be delivered on sheet

- PRINTING**
- Print on back side acc. to OUTLINE ARTWORK version on this drawing.
  - color text : Black 80007
  - color background : Bright Silver acc to 11126
  - Color of rectangular area: No printing, it will be transparent.
- ADHESIVE REQUIREMENTS**
- Rearside has to be self adhesive and protected with an easily removable layer
  - Adhesive specification equivalent to Mactac-Macband B1148

ENVIRONMENTAL REQUIREMENT :  
NO BANNED SUBSTANCES ACC. TO UAW-0480/100

		TOLERANCES UNLESS OTHERWISE STATED TOLERANTIES TENZIJ ANDERS VERMELD DIMENSION MAAT +/-0.2 ANGLE HOEK		TSU9200/37	
GENERAL ROUGHNESS ALGEMENE RUWHEID	UNIT EENH. mm	Polypropylene both sides high gloss <b>Thickness 0.125 mm.</b>		ITEM POST	ASSEMBLY NO. SAMENSTELLINGSNR.
SCALE SCHAAL	PROJ EUROP			ORDER NO./ORDERNR.	QUANT. AANTAL
CLASS NO 6NE100		<b>Approbation sticker</b> <b>TSU9200/37</b>		1 2007-06-01 2 2007-07-18	
NAME NAAM Heysse Gert		SUPERS. VERV. 01		110 — 01 10	
CHECK CONTR.		DAT. 2007-06-01		Property of Eigendom van N.V. PHILIPS GLOEILAMPENFABRIEKEN EINDHOVEN - NEDERLAND	