

**Reversion History:**

**Rev3.0 to 4.0:**

- 1. EMI improvement.

# **ARESCOM**

## **ND 1760**

## **ADSL WLAN**

## **MOTOROLA MPC850 MAIN BOARD**

### **P/N :**

### **Revision : 4A**

<b>ARESCOM</b>		
Title ND 1760		
Size	Document Number HEADER	Rev 4.0
Date:	Wednesday, August 08, 2001	Sheet 1 of 9

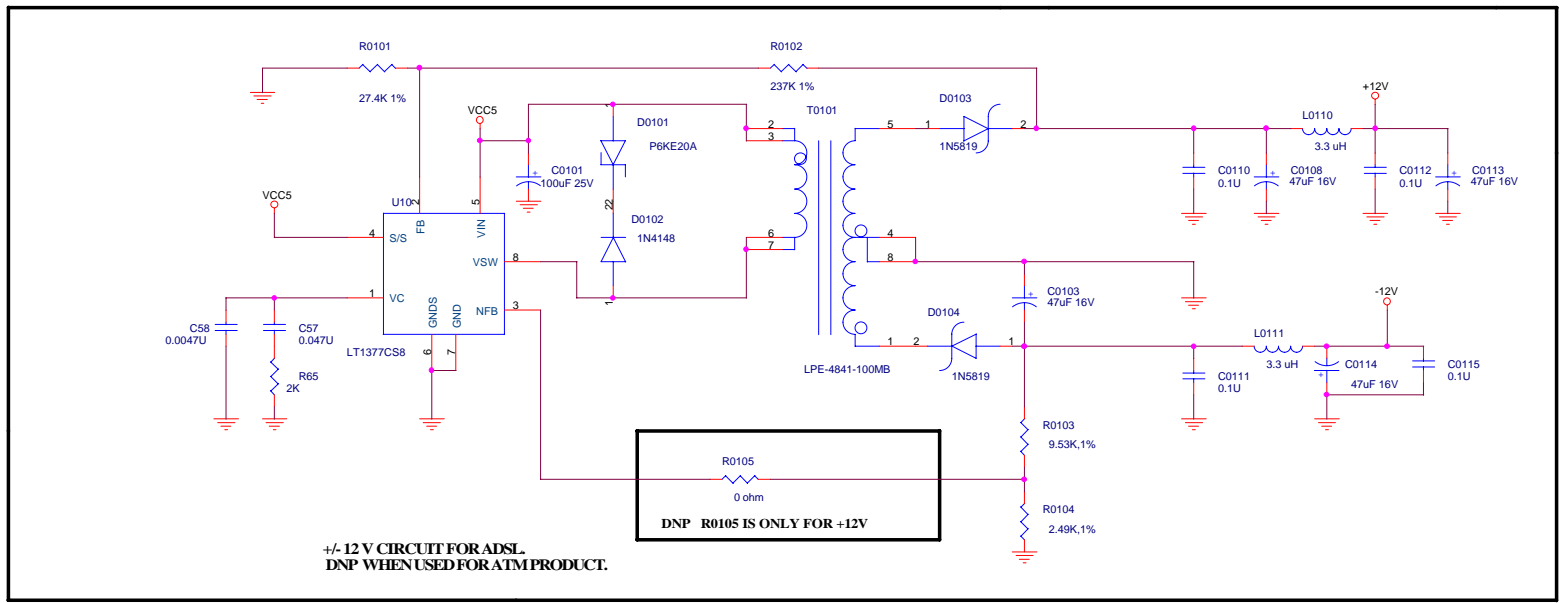
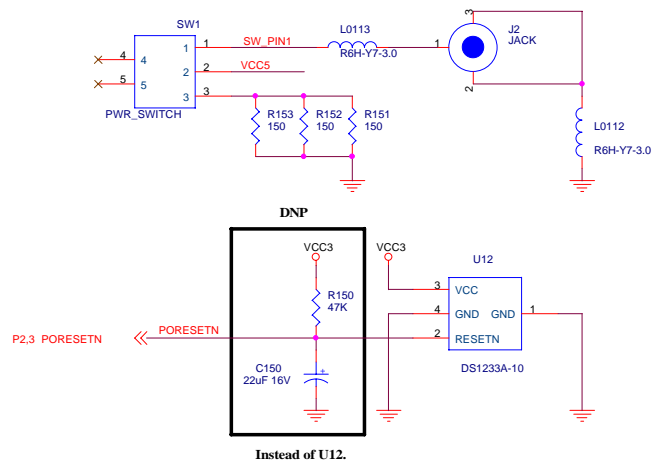
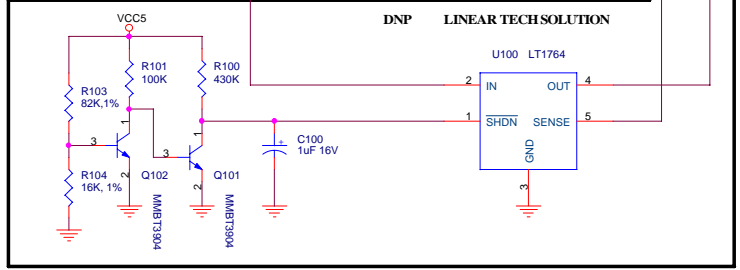
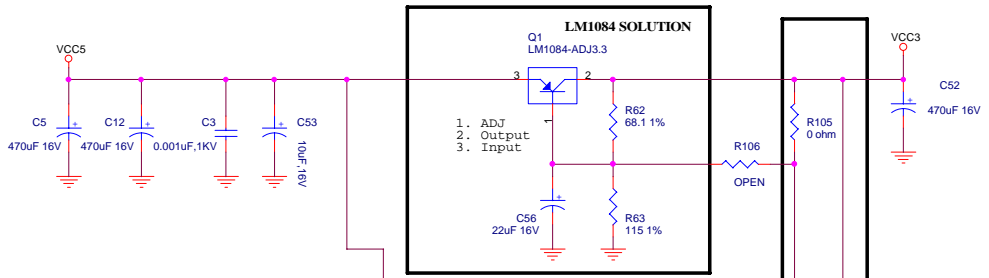

<b>ARES COM</b>		
Title ND 1760		
Size	Document Number POWER	Rev 4.0
Date:	Wednesday, August 08, 2001	Sheet 2 of 9

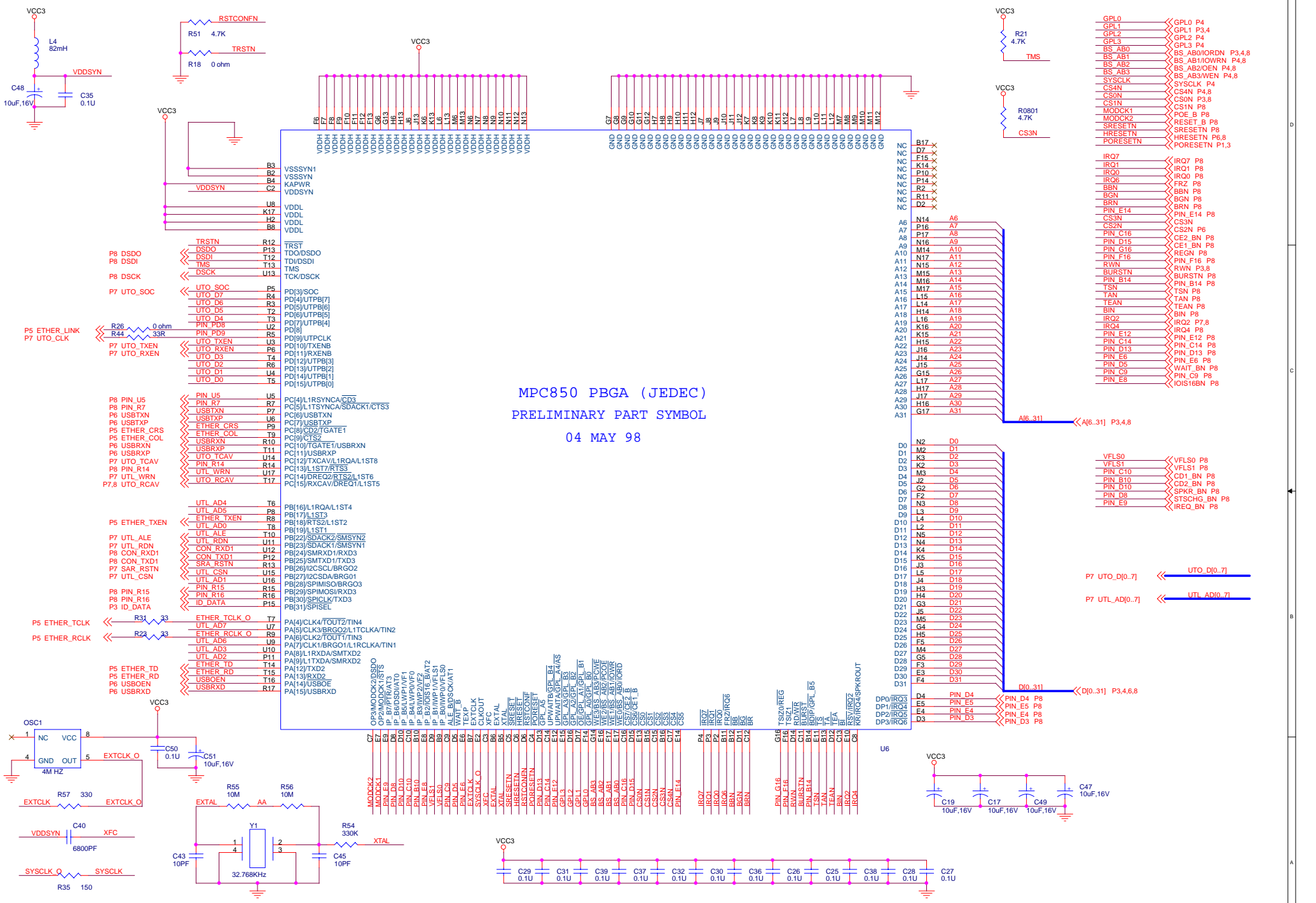

MPC850 PBGA (JEDEC)  
 PRELIMINARY PART SYMBOL  
 04 MAY 98

GPIO0	<<>	GPIO P4
GPIO1	<<>	GPIO P4.4
GPIO2	<<>	GPIO P4
GPIO3	<<>	GPIO P4
BS AB0	<<>	BS AB0/ORDN P3,4,8
BS AB1	<<>	BS AB2
BS AB2	<<>	BS AB2/OEN P4,8
BS AB3	<<>	BS AB3/WEN P4,8
SYSCLK	<<>	SYSCLK P4
CS4N	<<>	CS4N P4,8
CS0N	<<>	CS0N P3,8
CS1N	<<>	CS1N P8
MODCK1	<<>	MODCK1 P8
MODCK2	<<>	MODCK2 P8
SRESETN	<<>	SRESETN P8
HRESETN	<<>	HRESETN P6,8
PORESETN	<<>	PORESETN P1,3
GPIO4	<<>	GPIO P4
GPIO5	<<>	GPIO P4
GPIO6	<<>	GPIO P4
GPIO7	<<>	GPIO P4
GPIO8	<<>	GPIO P4
GPIO9	<<>	GPIO P4
GPIO10	<<>	GPIO P4
GPIO11	<<>	GPIO P4
GPIO12	<<>	GPIO P4
GPIO13	<<>	GPIO P4
GPIO14	<<>	GPIO P4
GPIO15	<<>	GPIO P4
GPIO16	<<>	GPIO P4
GPIO17	<<>	GPIO P4
GPIO18	<<>	GPIO P4
GPIO19	<<>	GPIO P4
GPIO20	<<>	GPIO P4
GPIO21	<<>	GPIO P4
GPIO22	<<>	GPIO P4
GPIO23	<<>	GPIO P4
GPIO24	<<>	GPIO P4
GPIO25	<<>	GPIO P4
GPIO26	<<>	GPIO P4
GPIO27	<<>	GPIO P4
GPIO28	<<>	GPIO P4
GPIO29	<<>	GPIO P4
GPIO30	<<>	GPIO P4
GPIO31	<<>	GPIO P4
GPIO32	<<>	GPIO P4
GPIO33	<<>	GPIO P4
GPIO34	<<>	GPIO P4
GPIO35	<<>	GPIO P4
GPIO36	<<>	GPIO P4
GPIO37	<<>	GPIO P4
GPIO38	<<>	GPIO P4
GPIO39	<<>	GPIO P4
GPIO40	<<>	GPIO P4
GPIO41	<<>	GPIO P4
GPIO42	<<>	GPIO P4
GPIO43	<<>	GPIO P4
GPIO44	<<>	GPIO P4
GPIO45	<<>	GPIO P4
GPIO46	<<>	GPIO P4
GPIO47	<<>	GPIO P4
GPIO48	<<>	GPIO P4
GPIO49	<<>	GPIO P4
GPIO50	<<>	GPIO P4
GPIO51	<<>	GPIO P4
GPIO52	<<>	GPIO P4
GPIO53	<<>	GPIO P4
GPIO54	<<>	GPIO P4
GPIO55	<<>	GPIO P4
GPIO56	<<>	GPIO P4
GPIO57	<<>	GPIO P4
GPIO58	<<>	GPIO P4
GPIO59	<<>	GPIO P4
GPIO60	<<>	GPIO P4
GPIO61	<<>	GPIO P4
GPIO62	<<>	GPIO P4
GPIO63	<<>	GPIO P4
GPIO64	<<>	GPIO P4
GPIO65	<<>	GPIO P4
GPIO66	<<>	GPIO P4
GPIO67	<<>	GPIO P4
GPIO68	<<>	GPIO P4
GPIO69	<<>	GPIO P4
GPIO70	<<>	GPIO P4
GPIO71	<<>	GPIO P4
GPIO72	<<>	GPIO P4
GPIO73	<<>	GPIO P4
GPIO74	<<>	GPIO P4
GPIO75	<<>	GPIO P4
GPIO76	<<>	GPIO P4
GPIO77	<<>	GPIO P4
GPIO78	<<>	GPIO P4
GPIO79	<<>	GPIO P4
GPIO80	<<>	GPIO P4
GPIO81	<<>	GPIO P4
GPIO82	<<>	GPIO P4
GPIO83	<<>	GPIO P4
GPIO84	<<>	GPIO P4
GPIO85	<<>	GPIO P4
GPIO86	<<>	GPIO P4
GPIO87	<<>	GPIO P4
GPIO88	<<>	GPIO P4
GPIO89	<<>	GPIO P4
GPIO90	<<>	GPIO P4
GPIO91	<<>	GPIO P4
GPIO92	<<>	GPIO P4
GPIO93	<<>	GPIO P4
GPIO94	<<>	GPIO P4
GPIO95	<<>	GPIO P4
GPIO96	<<>	GPIO P4
GPIO97	<<>	GPIO P4
GPIO98	<<>	GPIO P4
GPIO99	<<>	GPIO P4
GPIO100	<<>	GPIO P4
GPIO101	<<>	GPIO P4
GPIO102	<<>	GPIO P4
GPIO103	<<>	GPIO P4
GPIO104	<<>	GPIO P4
GPIO105	<<>	GPIO P4
GPIO106	<<>	GPIO P4
GPIO107	<<>	GPIO P4
GPIO108	<<>	GPIO P4
GPIO109	<<>	GPIO P4
GPIO110	<<>	GPIO P4
GPIO111	<<>	GPIO P4
GPIO112	<<>	GPIO P4
GPIO113	<<>	GPIO P4
GPIO114	<<>	GPIO P4
GPIO115	<<>	GPIO P4
GPIO116	<<>	GPIO P4
GPIO117	<<>	GPIO P4
GPIO118	<<>	GPIO P4
GPIO119	<<>	GPIO P4
GPIO120	<<>	GPIO P4
GPIO121	<<>	GPIO P4
GPIO122	<<>	GPIO P4
GPIO123	<<>	GPIO P4
GPIO124	<<>	GPIO P4
GPIO125	<<>	GPIO P4
GPIO126	<<>	GPIO P4
GPIO127	<<>	GPIO P4
GPIO128	<<>	GPIO P4
GPIO129	<<>	GPIO P4
GPIO130	<<>	GPIO P4
GPIO131	<<>	GPIO P4
GPIO132	<<>	GPIO P4
GPIO133	<<>	GPIO P4
GPIO134	<<>	GPIO P4
GPIO135	<<>	GPIO P4
GPIO136	<<>	GPIO P4
GPIO137	<<>	GPIO P4
GPIO138	<<>	GPIO P4
GPIO139	<<>	GPIO P4
GPIO140	<<>	GPIO P4
GPIO141	<<>	GPIO P4
GPIO142	<<>	GPIO P4
GPIO143	<<>	GPIO P4
GPIO144	<<>	GPIO P4
GPIO145	<<>	GPIO P4
GPIO146	<<>	GPIO P4
GPIO147	<<>	GPIO P4
GPIO148	<<>	GPIO P4
GPIO149	<<>	GPIO P4
GPIO150	<<>	GPIO P4

EMI improvement:  
 R31/R23 change from 10R to 33R.  
 R57 change from 10R to 330.  
 R35 change from 10R to 150.  
 Add R44=33R.

<b>ARESCOM</b>		
Title	ND 1760	
Size	Document Number	Rev
	MPC850SAR	4.0
Date:	Wednesday, August 08, 2001	Sheet 3 of 9

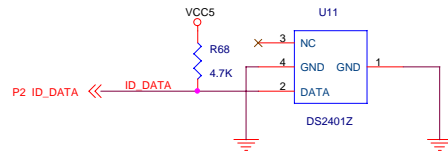
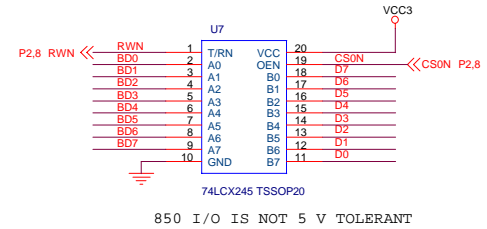
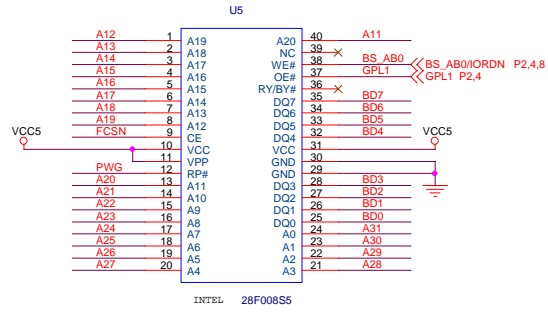
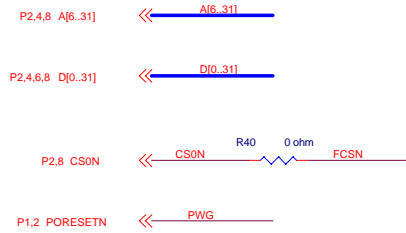
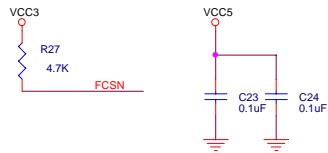

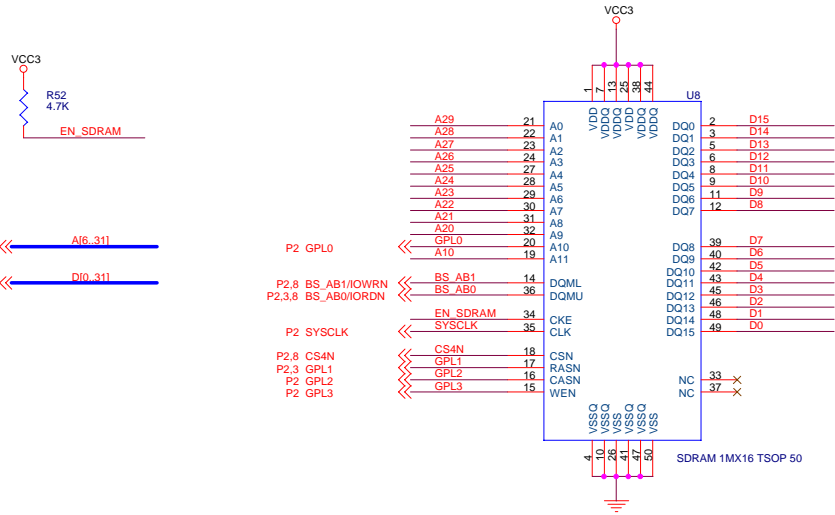

P2.3.8 A[6..31] << A[6..31]

P2.3.6,8 D[0..31] << D[0..31]

P2 GPL0 << GPL0

P2.8 BS\_AB1/IOWRN  
P2.3.8 BS\_AB0/IORDN << BS\_AB1, BS\_AB0

P2 SYSCLK << SYSCLK

P2.8 CS4N << CS4N

P2.3 GPL1 << GPL1

P2 GPL2 << GPL2

P2 GPL3 << GPL3

P2.8 BS\_AB3/WEN << BS\_AB3

P2.8 BS\_AB2/OEN << BS\_AB2

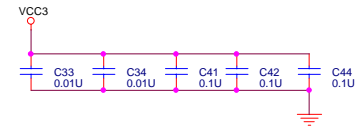
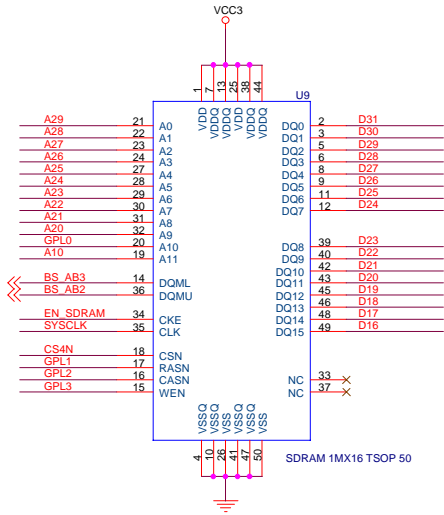

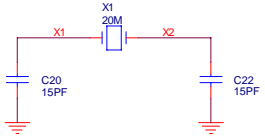
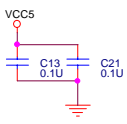
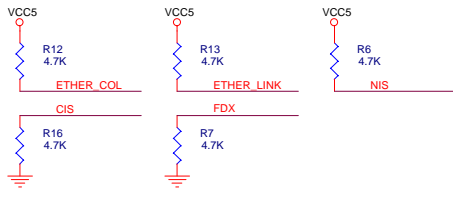

- ETHER\_CRS << ETHER\_CRS P2
- ETHER\_RCLK << ETHER\_RCLK P2
- ETHER\_TD << ETHER\_TD P2
- ETHER\_TXEN << ETHER\_TXEN P2
- P2 ETHER\_COL << ETHER\_COL
- P2 ETHER\_RD << ETHER\_RD
- P2 ETHER\_LINK << ETHER\_LINK
- P2 ETHER\_TCLK << ETHER\_TCLK

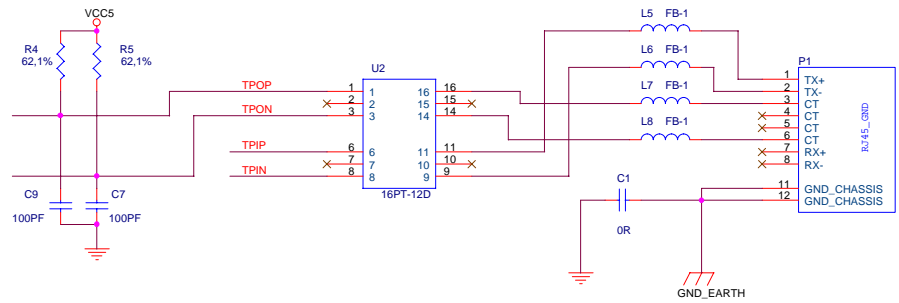
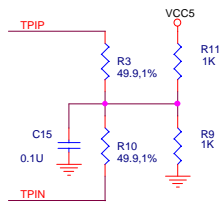
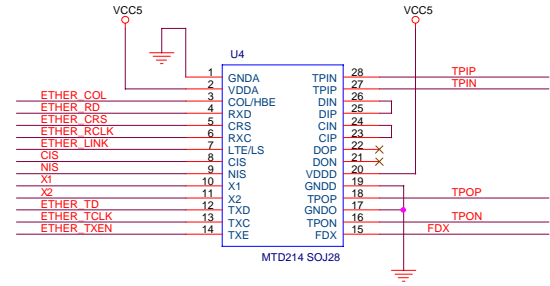

EMI improvement:  
 Add L5,L6,L7 and L8.  
 C1 change from 0.01uF to 0R.  
 C20,C22 change from 30pF to 15pF.

ARES COM		
Title	ND 1760	
Size	Document Number	Rev
	ETHERNET_PHY	4.0
Date:	Wednesday, August 08, 2001	Sheet 6 of 9

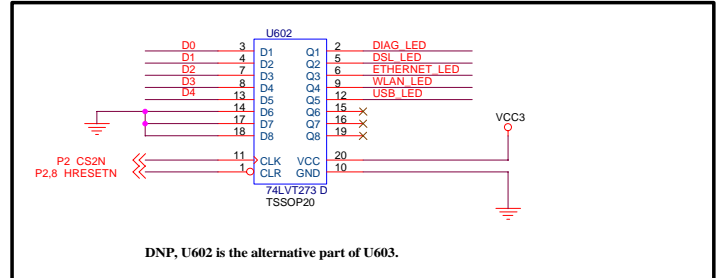
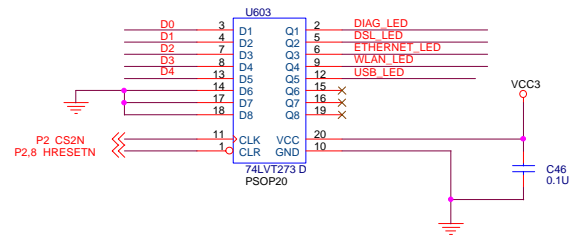
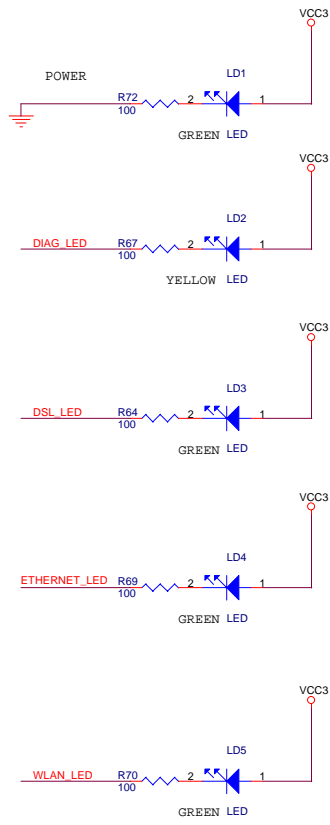

DNP, U602 is the alternative part of U603.

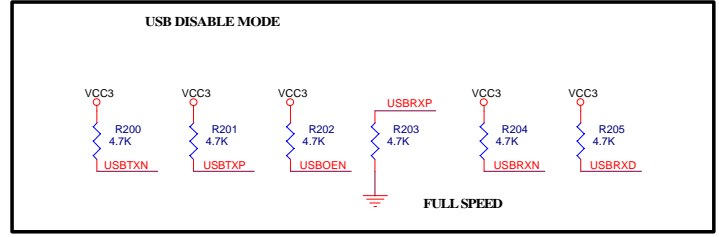

P2.3,4,8 D[0:31] ← D[0:31]

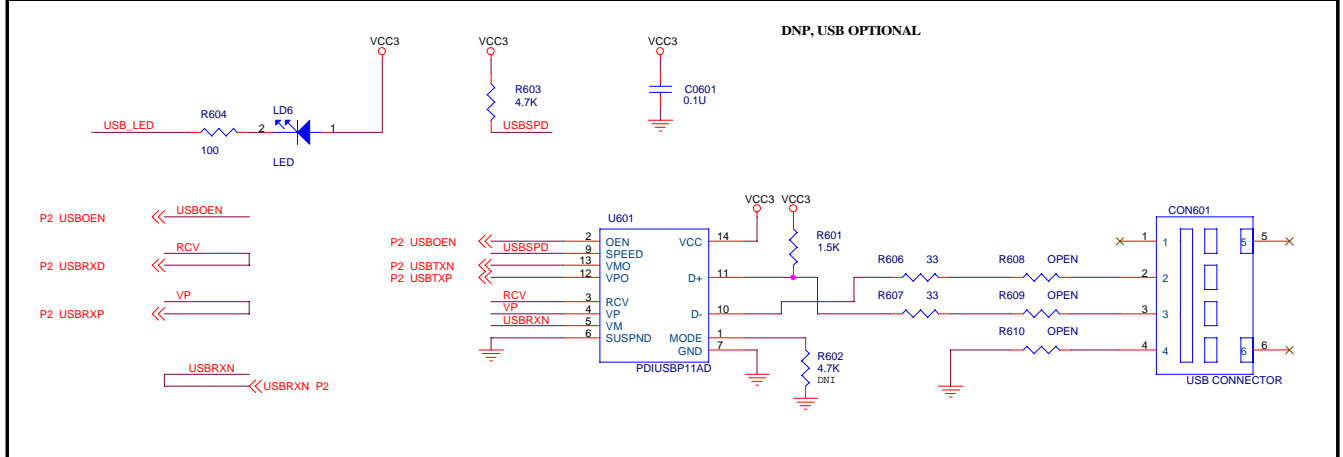

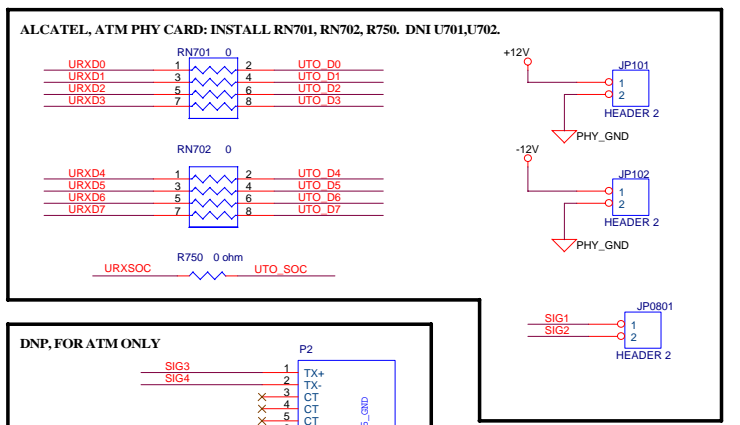
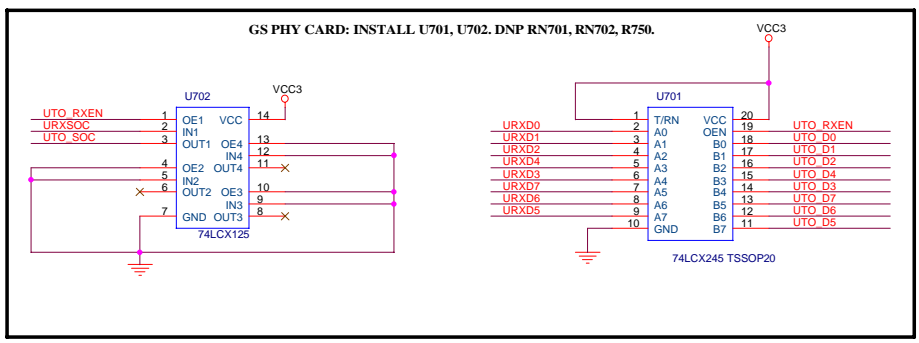
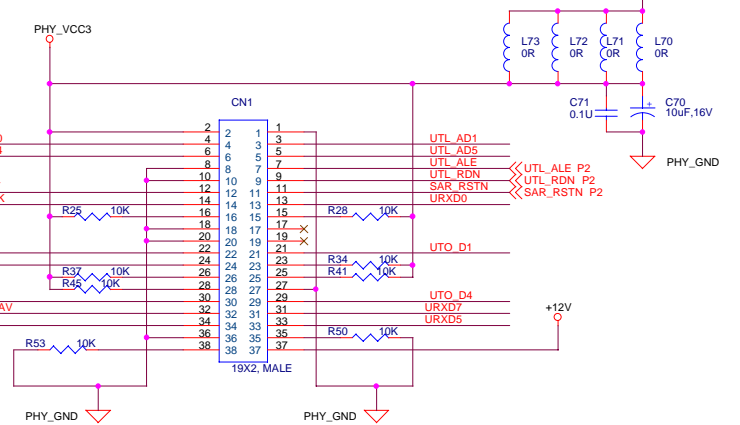
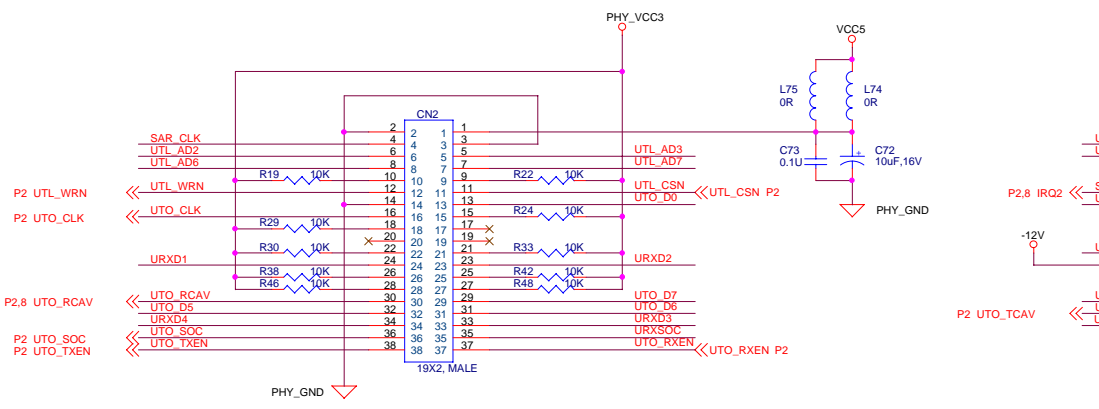

P2\_UTO\_D[0..7] << UTO\_D[0..7]  
 P2\_UTL\_AD[0..7] << UTL\_AD[0..7]

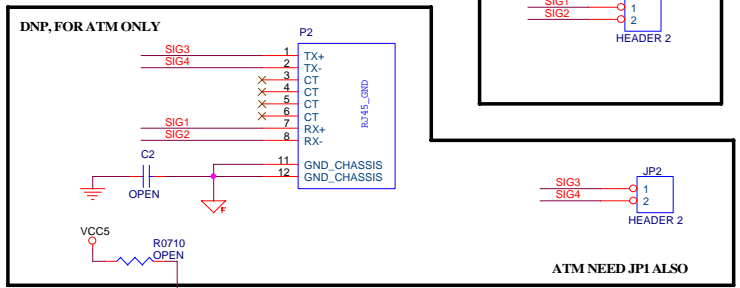
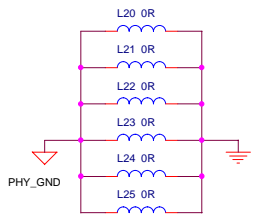

ATM NEED JPI ALSO

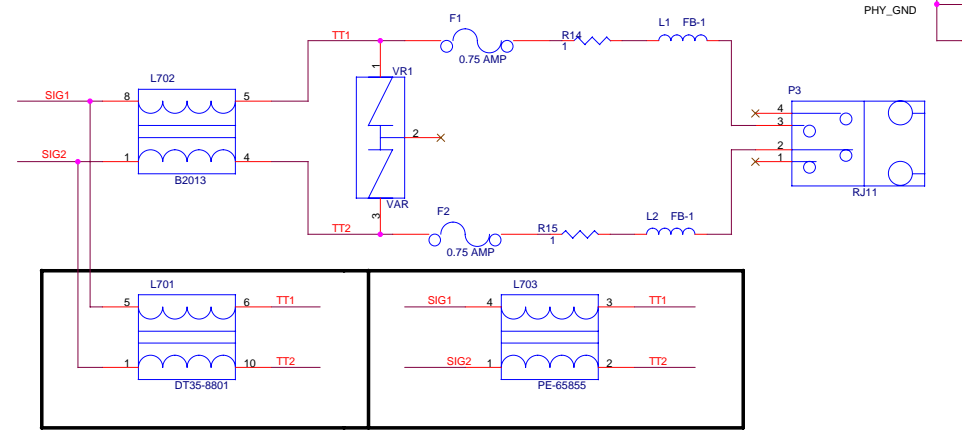

R0710 for 32M HZ ATM solution  
 R0711 for 34.56M HZ ADSL solution

EMI improvement:  
 L20 to L25 and L70 to L75 change from FB-1 to 0R.

<b>ARESCOM</b>		
Title	ND 1760	
Size	Document Number	Rev
	ADSL PHY CONNECTOR	4.0
Date:	Wednesday, August 08, 2001	Sheet 8 of 9



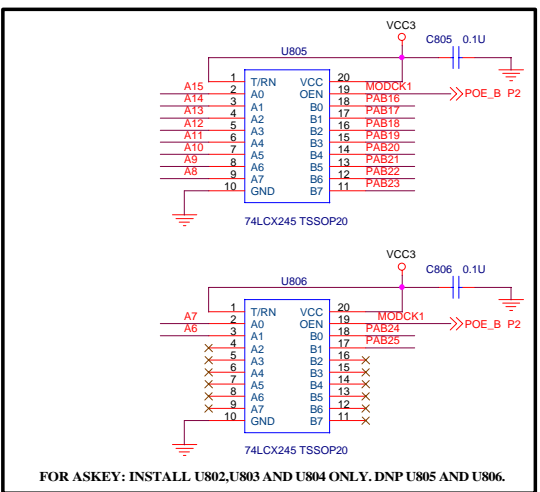
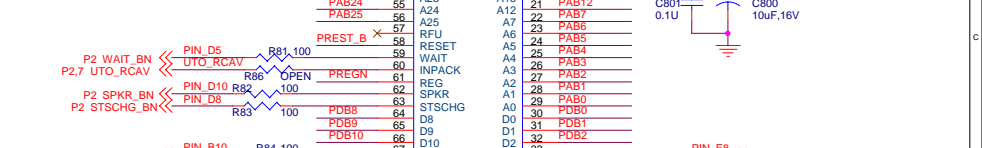
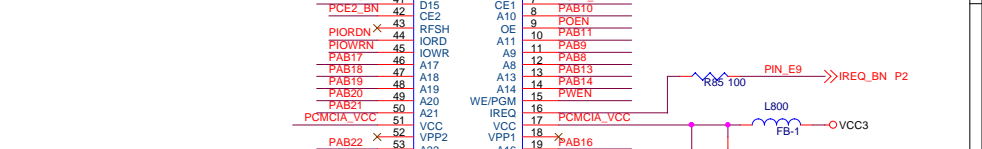
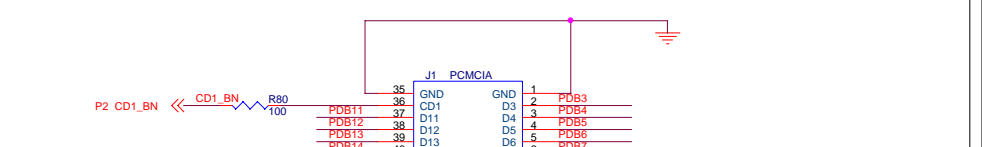
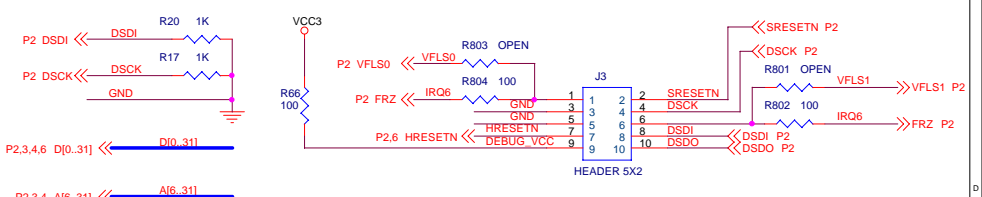
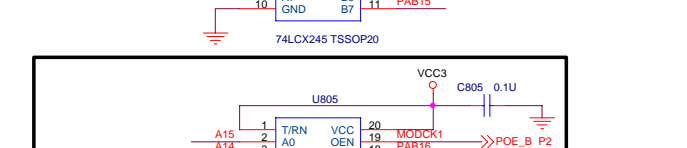
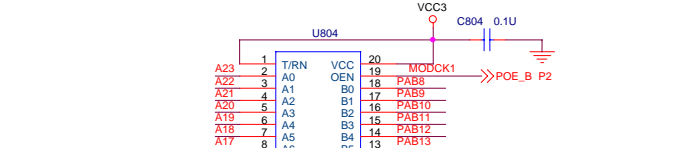
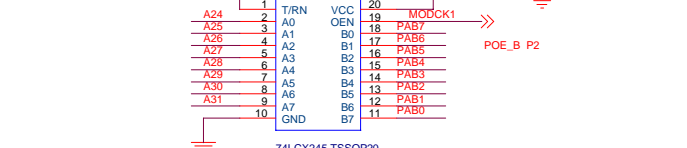
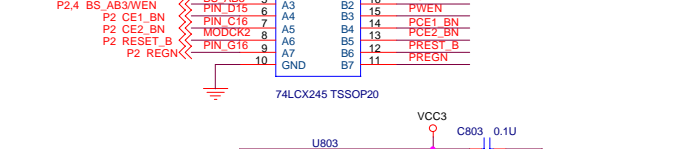
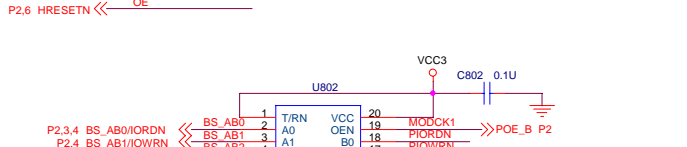
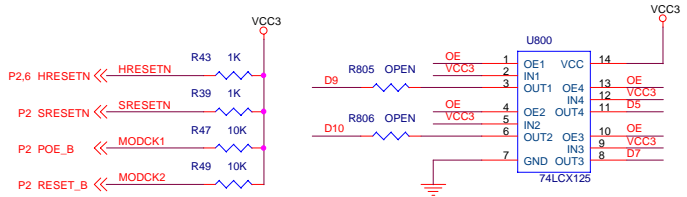
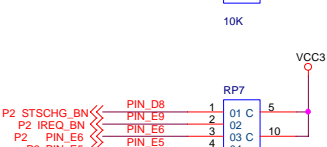
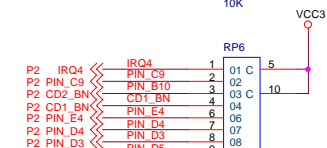
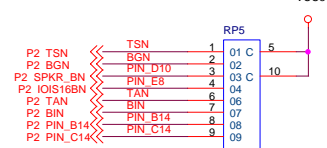
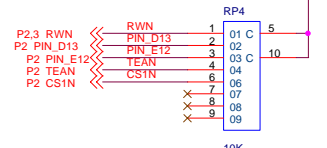
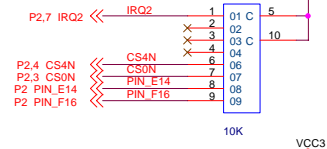
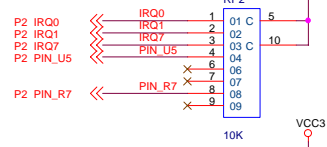
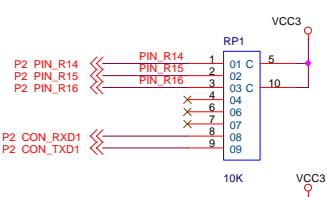

Note: Read is data from PCMCIA to MPC850. RWN=L, A to B

