

FCC PART 15C TEST REPORT FOR CERTIFICATION

On Behalf of

Acrox Technologies Co.,Ltd

Wireless Mouse

Model Number: M250R

FCC ID: PRDMU04

Prepared for : Arox Technologies Co.,Ltd
437,8f,Rui Guang Road,Nei Hu District,Taipei,Taiwan

Prepared By : EST Technology Co., Ltd.
Santun(guantai Road), Houjie Town,
DongGuan City,GuangDong, China.

Tel: 86-769-83081888-808

Report Number : ESTE-R1107004
Date of Test : July.01~14, 2011
Date of Report : July.14, 2011

TABLE OF CONTENTS

Description	Page
1. SUMMARY OF STANDARDS AND RESULTS.....	1-1
1.1. Description of Standards and Results	1-1
2. GENERAL INFORMATION	2-1
2.1. Description of Device (EUT)	2-1
2.2. Tested Supporting System Details	2-2
2.3. EUT Configuration and operation conditions for test.....	2-2
3. POWER LINE CONDUCTED EMISSION TEST	3-1
N/A.....	3-1
4. RADIATED EMISSION TEST	4-2
4.1. Test Equipment	4-2
4.2. Block Diagram of Test Setup.....	4-2
4.3. Radiated Emission Limit Standard: FCC 15.209 and 15.249	4-3
4.4. Operating Condition of EUT.....	4-4
4.5. Test Procedure.....	4-4
4.6. Radiated Emission Test Results	4-4
5. 20 DB BANDWIDTH TEST	5-1
5.1. Test Equipment	5-1
5.2. Limit.....	5-1
5.3. Test Results	5-1
6. BAND EDGE COMPLIANCE TEST	6-1
6.1. Test Equipment	6-1
6.2. Limit.....	6-1
6.3. Test Produce	6-1
6.4. Test Results	6-2
7. PHOTOGRAPH OF TEST	7-1
7.1. Photos of Radiated Emission Test (30-1000MHz)	7-1
8. PHOTOGRAPH OF EUT	8-1

TEST REPORT CERTIFICATION



Applicant : Acrox Technologies Co.,Ltd
Manufacturer : Acrox Technologies Co.,Ltd
EUT Description : Wireless Mouse
FCC ID : PRDMU04
(A) MODEL NO. : M250R
(B) SERIAL NO. : N/A
(C) POWER SUPPLY : DC 1.5V from battery
(D) TEST VOLTAGE : DC 1.5V from battery

Tested for comply with:
FCC Rules and Regulations Part 15 Subpart C:2008

Test procedure used:
ANSI C63.10:2009

The device described above is tested by EST Technology Co., Ltd. to confirm comply with all the FCC Part 15 Subpart C requirements.

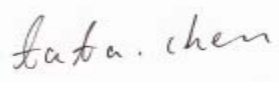
The test results are contained in this test report and EST Technology Co., Ltd. is assumed full responsibility for the accuracy and completeness of these tests. Also, this report shows that the Equipment under test (EUT) is to be technically compliant with the FCC requirements.

Prepared by:	Tested by:	Approved by:
		
_____ Coco / Assistant	_____ Tata Chen / Engineer	_____ Iceman Hu / Manager
<p><i>This test report is based on a single evaluation of one sample of above mentioned products. It is not permitted to be duplicated in extracts without written approval of EST Technology Co., Ltd.</i></p>		

1. SUMMARY OF STANDARDS AND RESULTS

1.1. Description of Standards and Results

The EUT have been tested according to the applicable standards as referenced below.

EMISSION		
Description of Test Item	Standard	Results
Power Line Conducted Emission Test	FCC Part 15C: 15.207 ANSI C63.10-2009	N/A
Radiated Emission Test	FCC Part 15C: 15.209 FCC Part 15C: 15.249 ANSI C63.10-2009	PASS
Band Edge Compliance Test	FCC Part 15: 15.249 ANSI C63.10-2009	PASS
20dB Bandwidth Test	FCC Part 15: 15.215 ANSI C63.10-2009	PASS

2. GENERAL INFORMATION

2.1. Description of Device (EUT)

Product Name	: Wireless Mouse
Model Number	: M250R
FCC ID	: PRDMU04
Operation frequency	: 2408MHz~2474MHz
Antenna	: Integrated PCB antenna, -7.5dBi gain
Modulation	: GFSK
Power Supply	: DC 1.5V from battery Note: New battery were used for all test.
Applicant	: Acrox Technologies Co.,Ltd 437,8f,Rui Guang Road,Nei Hu District,Taipei,Taiwan.
Manufacturer	: Acrox Technologies Co.,Ltd Hsinmin Industrial,Changan Town, Dongguan City
Sample Type	: Prototype production

2.2. Tested Supporting System Details

N/A

2.3. EUT Configuration and operation conditions for test.

EUT

EUT work continues Tx mode and frequency as below:

Channel	Frequency
Low	2408MHz
Middle	2440MHz
High	2474MHz

Note: A typical modulation was applied when performance test.

3. POWER LINE CONDUCTED EMISSION TEST

N/A

Note: This test only apply to device powered with AC mains.

4. RADIATED EMISSION TEST

4.1. Test Equipment

Frequency rang: 30~1000MHz

Item	Equipment	Manufacturer	Model No.	Serial No.	Last Cal.	Cal. Interval
1	4#Chamber	AUDIX	N/A	N/A	Dec.05, 10	1 Year
2	EMI Spectrum	Agilent	E4407B	MY41440292	May.08, 11	1 Year
3	Test Receiver	Rohde & Schwarz	ESVS10	834468/011	May.08, 11	1 Year
4	Amplifier	HP	8447D	2648A04738	May.08, 11	1 Year
5	Bilog Antenna	Schaffner	CBL6112D	25237	Mar. 27,11	1 Year
6	RF Cable	MIYAZAKI	8D-FB	3# Chamber No.1	May.08, 11	1 Year
7	Coaxial Switch	Anritsu	MP59B	M73989	May.08, 11	1 Year

Frequency rang: above 1000MHz

Item	Equipment	Manufacturer	Model No.	Serial No.	Last Cal.	Cal. Interval
1	Spectrum Analyzer	Agilent	E4446A	US44300459	May.08, 11	1 Year
2	Horn Antenna	EMCO	3115	9607-4877	May.25, 11	1.5 Year
3	Horn Antenna	EMCO	3116	00060089	May.25, 11	1.5 Year
4	Amplifier	Agilent	8449B	3008A00863	May.08, 11	1 Year
5	RF Cable	Hubersuhner	SUCOFLEX102	28620/2	May.08, 11	1 Year
6	RF Cable	Hubersuhner	SUCOFLEX102	29091/2	May.08, 11	1 Year

4.2. Block Diagram of Test Setup

For frequency range 30MHz-1000MHz

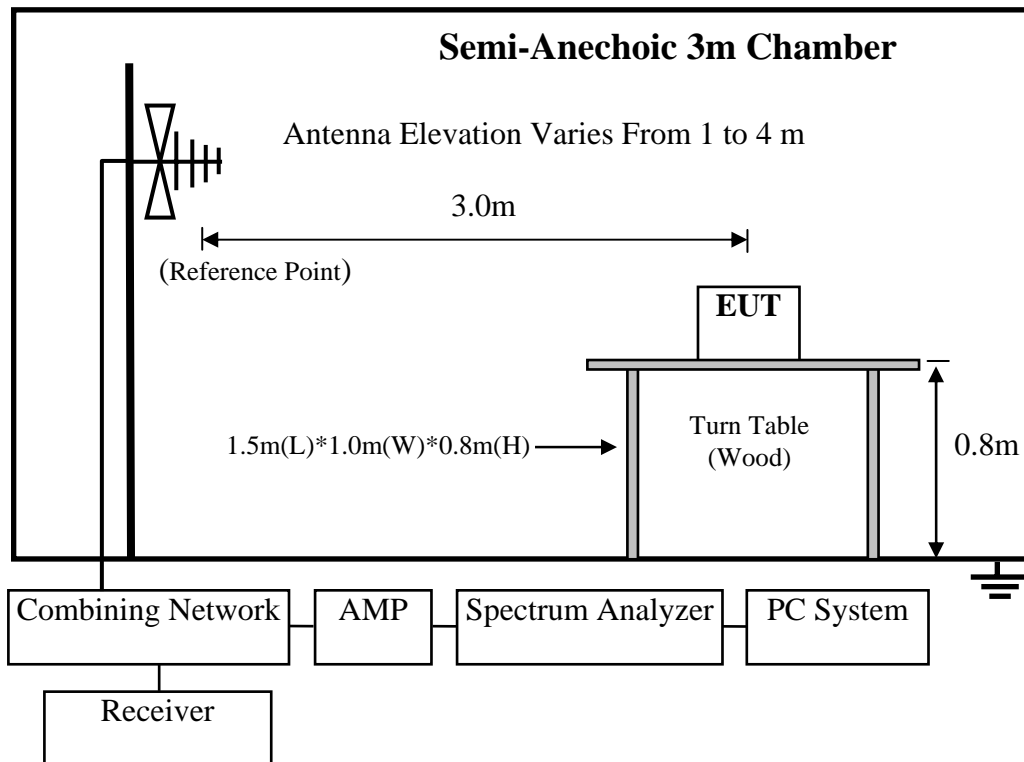

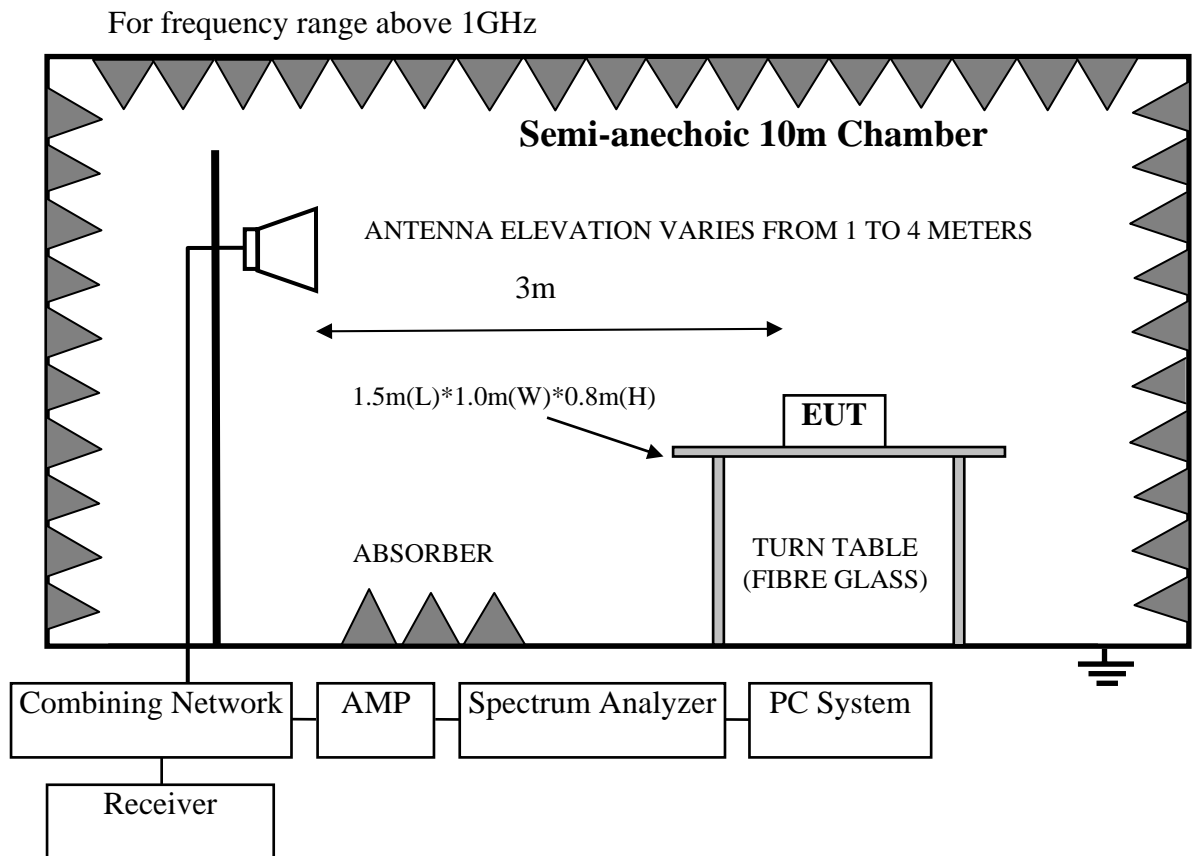

4.3. Radiated Emission Limit Standard: FCC 15.209 and 15.249

FREQUENCY MHz	DISTANCE Meters	FIELD STRENGTHS LIMIT	
		µV/m	dB(µV)/m
30 ~ 88	3	100	40.0
88 ~ 216	3	150	43.5
216 ~ 960	3	200	46.0
960 ~ 1000	3	500	54.0
Above 1000MHz	3	74.0 dB(µV)/m (Peak) 54.0 dB(µV)/m (Average)	
Field Strength of fundamental emissions for 2.4GHz-2.4835GHz	3	114.0 dB(µV)/m (Peak) 94.0 dB(µV)/m (Average)	

- Remark :
- (1) Emission level $dB\mu V = 20 \log$ Emission level $\mu V/m$
 - (2) The smaller limit shall apply at the cross point between two frequency bands.
 - (3) Distance is the distance in meters between the measuring instrument, antenna and the closest point of any part of the device or system.
 - (4) The emission limits shown in the above table are based on measurements employing a CISPR quasi-peak detector except for the frequency bands 9-90 kHz, 110-490 kHz and above 1000 MHz. Radiated emission limits in these three bands are based on measurements employing an average detector.

4.4. Operating Condition of EUT

- 4.4.1. Setup the EUT and simulator as shown as Section 4.2.
- 4.4.2. Turned on the power of all equipment.
- 4.4.3. Let EUT work in test mode (Tx mode) and test it.

4.5. Test Procedure

The EUT and its simulators are placed on a turn table, which is 0.8 meter high above ground. The turn table can rotate 360 degrees to determine the position of the maximum emission level. The EUT is set 3 meters away from the receiving antenna, which is mounted on a antenna tower. The antenna can be moved up and down between 1 meter and 4 meters to find out the maximum emission level. Broadband antenna (calibrated bilog antenna) is used as receiving antenna. Both horizontal and vertical polarization of the antenna is set on Test. In order to find the maximum emission levels, all of the interface cables must be manipulated according to ANSI C63.10-2009 on radiated emission Test.

This exploratory test was performed with EUT in X, Y, Z position with a USB extend line (0.5m long), and the worse case was found when EUT in X position and direct connected to PC as the test photo indicated and so the final test was performed with this configuration.

The bandwidth of the EMI test receiver is set at 120kHz for frequency range from 30MHz to 1000 MHz

The bandwidth of the Spectrum Analyzer's RBW is set at 1MHz and VBW is set at 3MHz for peak emissions measurement above 1GHz, and 1MHz RBW, 10Hz VBW for average measurement above 1GHz.

Note: For fundamental emissions, it's bandwidth is about 1.3MHz, so the Spectrum Analyzer's RBW was set at 2MHz and VBW was set at 3MHz for fundamental emissions measure.

4.6. Radiated Emission Test Results

PASS.

All the emissions from 30MHz to 25GHz were comply with the 15.209 Limit.

Emissions from 30MHz to 1GHz:

EST Technology

San Tun Management Zone, Houjie Town,
Dongguan City, Guangdong, China
Tel: +86-769-83081888
Fax: +86-769-83081878

Data: 1 File: D:\test data\W\WangHong.EMI (109)

Date: 2011-07-11 Time: 14:19:05

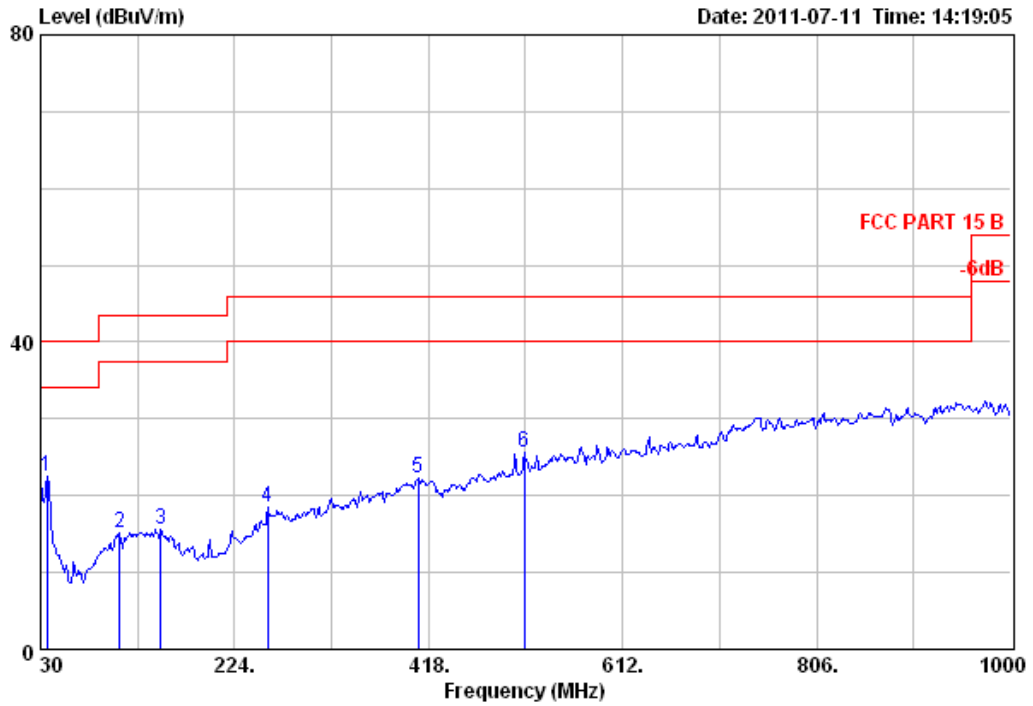

Site no. : 3m Chamber Data no. : 1
 Dis. / Ant. : 3m 27137 Ant. pol. : VERTICAL
 Limit : FCC PART 15 B
 Env. / Ins. : Temp:25.6'; Humi:56%; Press:101.52kPa
 Engineer : Tony
 EUT : Wireless Mouse
 Power : DC 1.5V
 M/N : M250R
 Test Mode : TX 2408

	Freq. (MHz)	Ant. Factor (dB/m)	Cable Loss (dB)	Reading (dBuV)	Emission Level (dBuV/m)	Limits (dBuV/m)	Margin (dB)	Remark
1	36.79	14.52	0.61	7.34	22.47	40.00	17.53	QP
2	109.54	10.44	1.24	3.57	15.25	43.50	28.25	QP
3	150.28	10.86	1.43	3.33	15.62	43.50	27.88	QP
4	256.98	12.63	2.13	3.63	18.39	46.00	27.61	QP
5	407.33	16.22	2.84	3.25	22.31	46.00	23.69	QP
6	514.03	17.95	3.54	4.03	25.52	46.00	20.48	QP



EST Technology

San Tun Management Zone, Houjie Town,
Dongguan City, Guangdong, China
Tel: +86-769-83081888
Fax: +86-769-83081878

Data: 2 File: D:\test data\W\WangHong.EMI (109)

Date: 2011-07-11 Time: 14:23:07

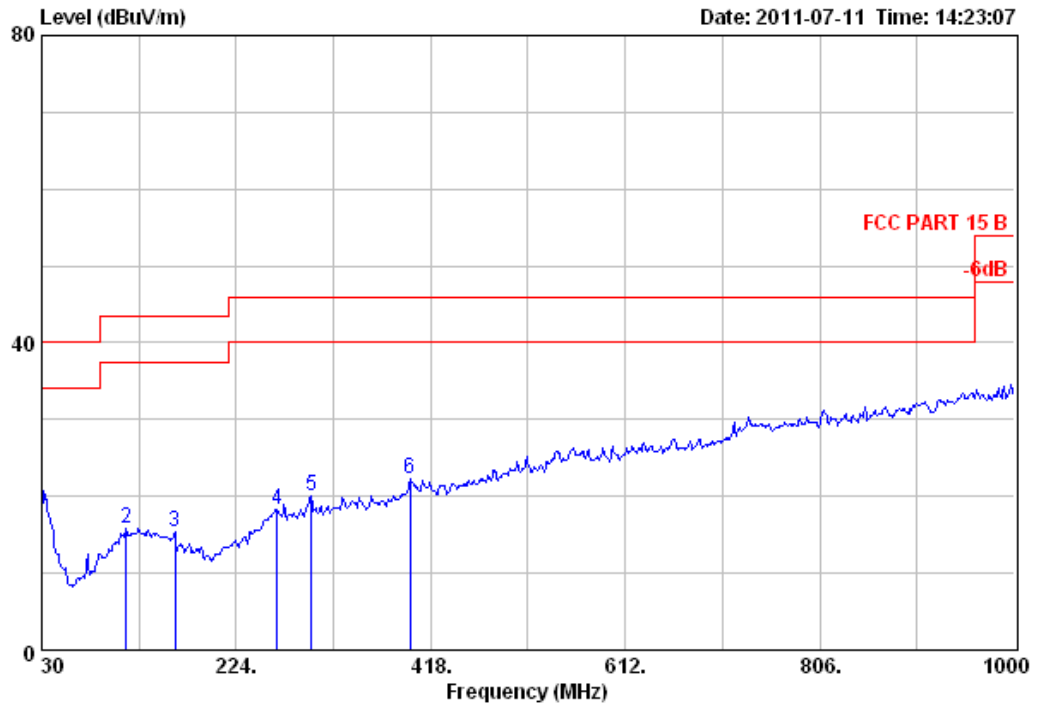

Site no. : 3m Chamber Data no. : 2
 Dis. / Ant. : 3m 27137 Ant. pol. : HORIZONTAL
 Limit : FCC PART 15 B
 Env. / Ins. : Temp:25.6';Humi:56%;Press:101.52kPa
 Engineer : Tony
 EUT : Wireless Mouse
 Power : DC 1.5V
 M/N : M250R
 Test Mode : TX 2408

No.	Freq. (MHz)	Ant. Factor (dB/m)	Cable Loss (dB)	Emission Reading (dBuV)	Emission Level (dBuV/m)	Limits (dBuV/m)	Margin (dB)	Remark
1	30.00	18.30	0.50	2.57	21.37	40.00	18.63	QP
2	114.39	10.85	1.24	3.66	15.75	43.50	27.75	QP
3	162.89	10.01	1.41	3.96	15.38	43.50	28.12	QP
4	264.74	12.94	2.23	3.16	18.33	46.00	27.67	QP
5	298.69	13.00	2.62	4.43	20.05	46.00	25.95	QP
6	397.63	15.96	2.86	3.39	22.21	46.00	23.79	QP



EST Technology

San Tun Management Zone, Houjie Town,
 Dongguan City, Guangdong, China
 Tel: +86-769-83081888
 Fax: +86-769-83081878

Data: 3 File: D:\test data\W\WangHong.EMI (109)

Date: 2011-07-11 Time: 14:28:15

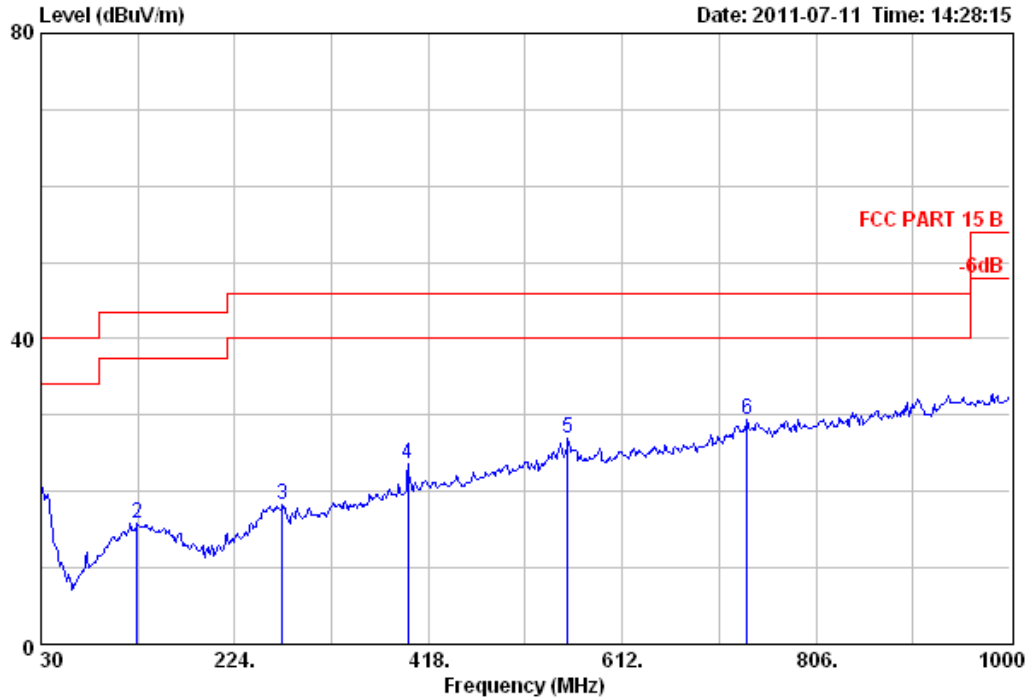

Site no. : 3m Chamber Data no. : 3
 Dis. / Ant. : 3m 27137 Ant. pol. : HORIZONTAL
 Limit : FCC PART 15 B
 Env. / Ins. : Temp:25.6';Humi:56%;Press:101.52kPa
 Engineer : Tony
 EUT : Wireless Mouse
 Power : DC 1.5V
 M/N : M250R
 Test Mode : TX 2440

No.	Ant. Cable			Emission				Remark
	Freq. (MHz)	Factor (dB/m)	Loss (dB)	Reading (dBuV)	Level (dBuV/m)	Limits (dBuV/m)	Margin (dB)	
1	30.00	18.30	0.50	2.22	21.02	40.00	18.98	QP
2	126.03	11.34	1.35	3.07	15.76	43.50	27.74	QP
3	271.53	12.49	2.25	3.50	18.24	46.00	27.76	QP
4	397.63	15.96	2.86	4.70	23.52	46.00	22.48	QP
5	557.68	19.66	3.61	3.60	26.87	46.00	19.13	QP
6	737.13	22.30	4.58	2.63	29.51	46.00	16.49	QP



EST Technology

San Tun Management Zone, Houjie Town,
 Dongguan City, Guangdong, China
 Tel: +86-769-83081888
 Fax: +86-769-83081878

Data: 4 File: D:\test data\W\WangHong.EMI (109)

Date: 2011-07-11 Time: 14:32:22

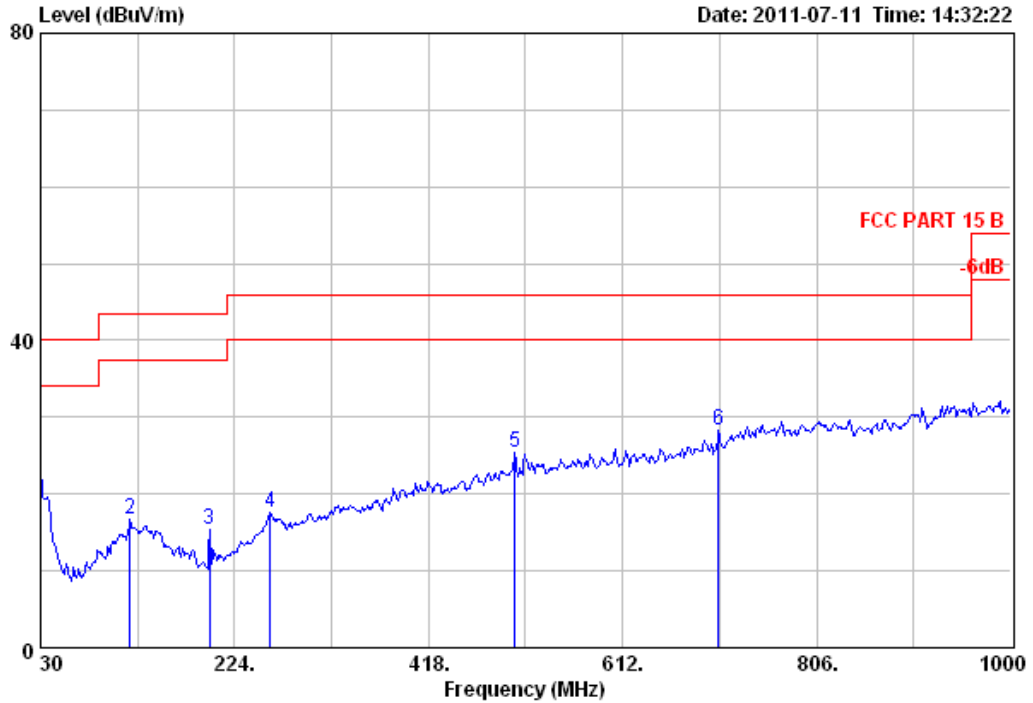

Site no. : 3m Chamber Data no. : 4
 Dis. / Ant. : 3m 27137 Ant. pol. : VERTICAL
 Limit : FCC PART 15 B
 Env. / Ins. : Temp:25.6'; Humi:56%; Press:101.52kPa
 Engineer : Tony
 EUT : Wireless Mouse
 Power : DC 1.5V
 M/N : M250R
 Test Mode : TX 2440

No.	Freq. (MHz)	Ant. Factor (dB/m)	Cable Loss (dB)	Emission		Limits (dBuV/m)	Margin (dB)	Remark
				Reading (dBuV)	Level (dBuV/m)			
1	30.00	18.30	0.50	3.85	22.65	40.00	17.35	QP
2	119.24	11.11	1.31	4.21	16.63	43.50	26.87	QP
3	198.78	7.71	1.69	5.87	15.27	43.50	28.23	QP
4	259.89	12.97	2.28	2.42	17.67	46.00	28.33	QP
5	504.33	17.90	3.47	4.00	25.37	46.00	20.63	QP
6	708.03	20.92	4.32	3.00	28.24	46.00	17.76	QP



EST Technology

San Tun Management Zone, Houjie Town,
 Dongguan City, Guangdong, China
 Tel: +86-769-83081888
 Fax: +86-769-83081878

Data: 5 File: D:\test data\W\WangHong.EMI (109)

Date: 2011-07-11 Time: 14:36:07

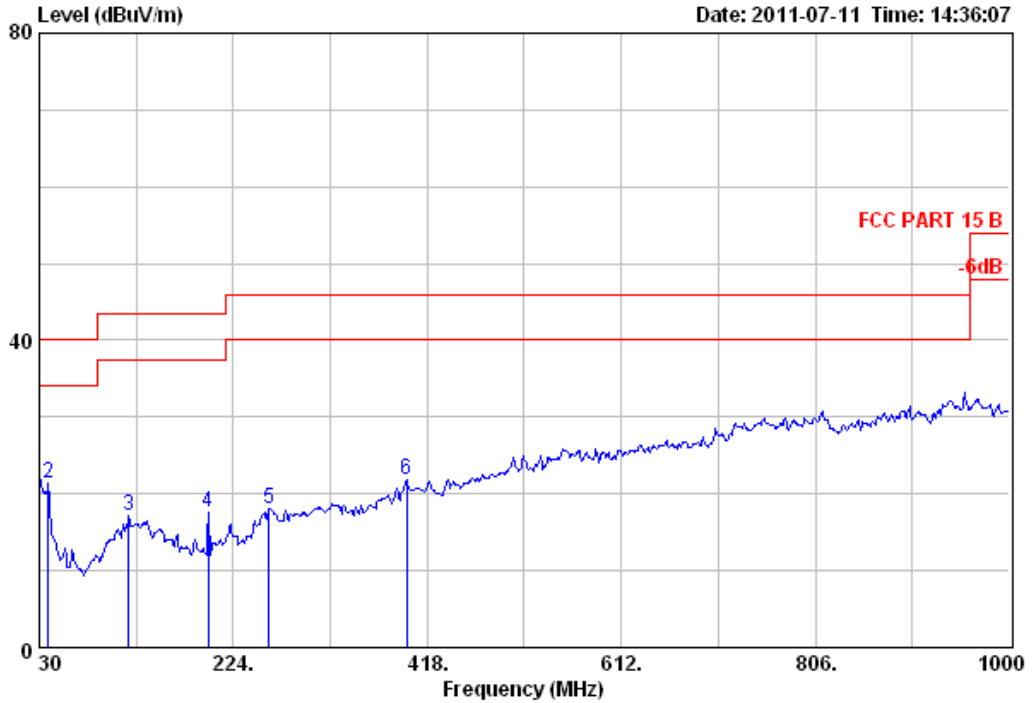

Site no. : 3m Chamber Data no. : 5
 Dis. / Ant. : 3m 27137 Ant. pol. : VERTICAL
 Limit : FCC PART 15 B
 Env. / Ins. : Temp:25.6'; Humi:56%; Press:101.52kPa
 Engineer : Tony
 EUT : Wireless Mouse
 Power : DC 1.5V
 M/N : M250R
 Test Mode : TX 2474

No.	Freq. (MHz)	Ant. Factor (dB/m)	Cable Loss (dB)	Reading (dBuV)	Emission			Remark
					Level (dBuV/m)	Limits (dBuV/m)	Margin (dB)	
1	30.00	18.30	0.50	3.64	22.44	40.00	17.56	QP
2	38.73	13.48	0.66	7.21	21.35	40.00	18.65	QP
3	119.24	11.11	1.31	4.70	17.12	43.50	26.38	QP
4	198.78	7.71	1.69	8.17	17.57	43.50	25.93	QP
5	259.89	12.97	2.28	2.87	18.12	46.00	27.88	QP
6	397.63	15.96	2.86	3.09	21.91	46.00	24.09	QP



EST Technology

San Tun Management Zone, Houjie Town,
Dongguan City, Guangdong, China
Tel: +86-769-83081888
Fax: +86-769-83081878

Data: 6 File: D:\test data\W\WangHong.EMI (109)

Date: 2011-07-11 Time: 14:40:03

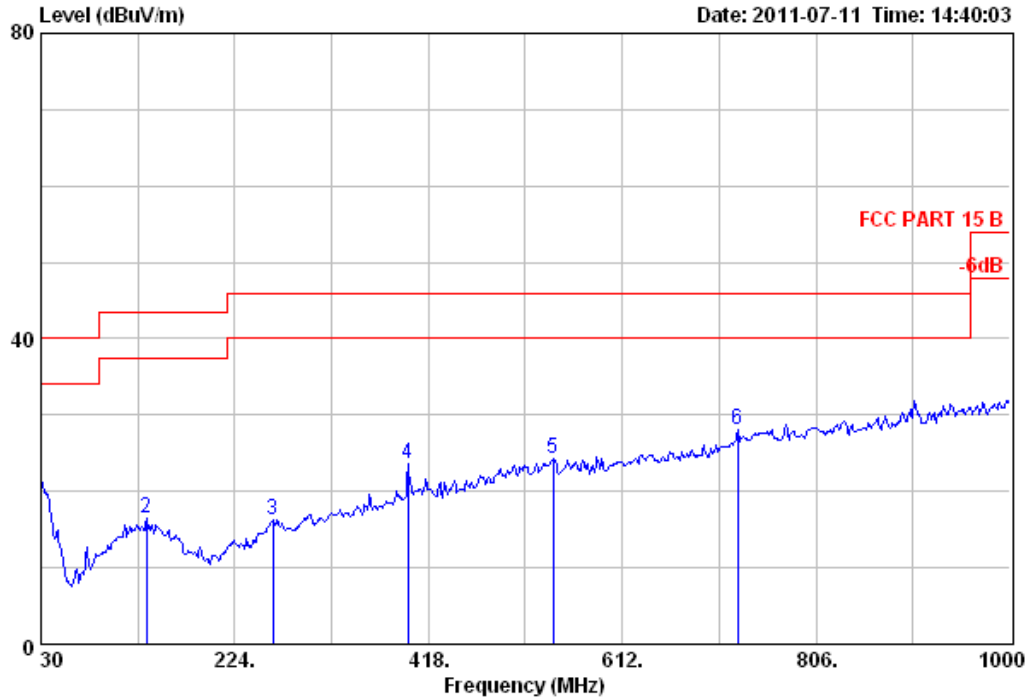

Site no. : 3m Chamber Data no. : 6
 Dis. / Ant. : 3m 27137 Ant. pol. : HORIZONTAL
 Limit : FCC PART 15 B
 Env. / Ins. : Temp:25.6';Humi:56%;Press:101.52kPa
 Engineer : Tony
 EUT : Wireless Mouse
 Power : DC 1.5V
 M/N : M250R
 Test Mode : TX 2474

	Freq. (MHz)	Ant. Factor (dB/m)	Cable Loss (dB)	Reading (dBuV)	Emission Level (dBuV/m)	Limits (dBuV/m)	Margin (dB)	Remark
1	30.00	18.30	0.50	2.64	21.44	40.00	18.56	QP
2	135.73	11.38	1.28	3.91	16.57	43.50	26.93	QP
3	261.83	12.96	2.15	1.26	16.37	46.00	29.63	QP
4	397.63	15.96	2.86	4.81	23.63	46.00	22.37	QP
5	543.13	19.46	3.51	1.22	24.19	46.00	21.81	QP
6	727.43	21.97	4.55	1.65	28.17	46.00	17.83	QP

Emissions from 1GHz to 25GHz:

Data: 1 File: E:\2010 report data\J201110311.EM6 (34)

Level (dBuV/m) Date: 2011-07-12

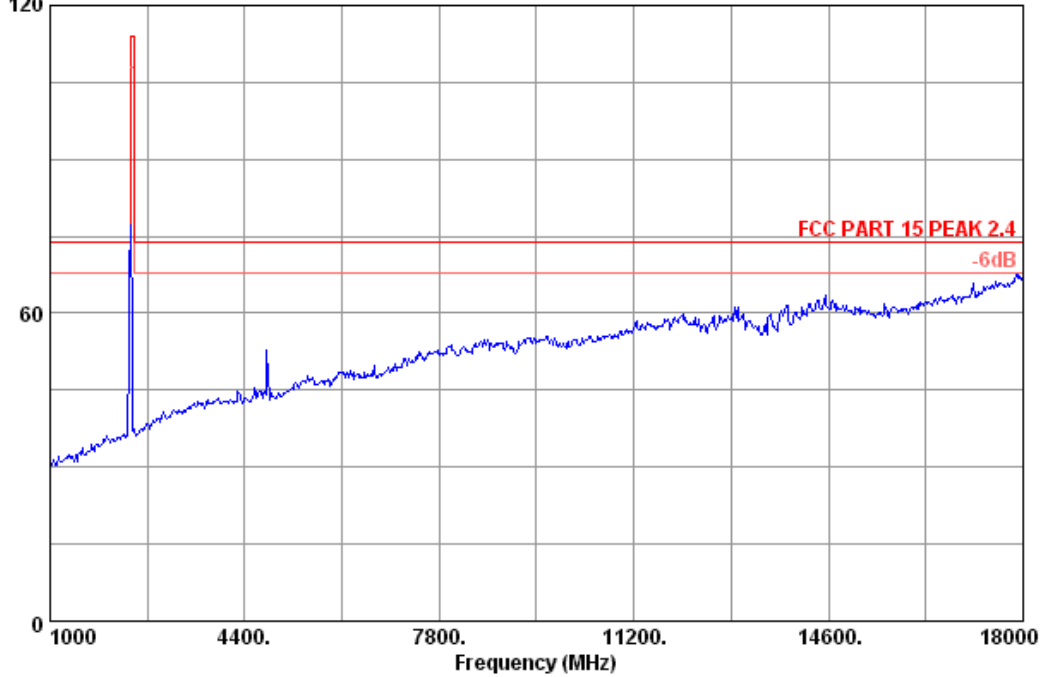

Site no.	: 3# Chamber	Data no. :	1
Dis. / Ant.	: 3m 3115(0911)	Ant. pol. :	VERTICAL
Limit	: FCC PART 15 PEAK 2.4	Engineer :	TaTa Chen
Env. / Ins.	: 23°C/54%		
EUT	: Wireless Mouse		
Power	: DC 1.5V		
Test mode	: TX 2408		
M/N	: M250R		

Data: 2 File: E:\2010 report data\J\20110311.EM6 (34) Date: 2011-07-12

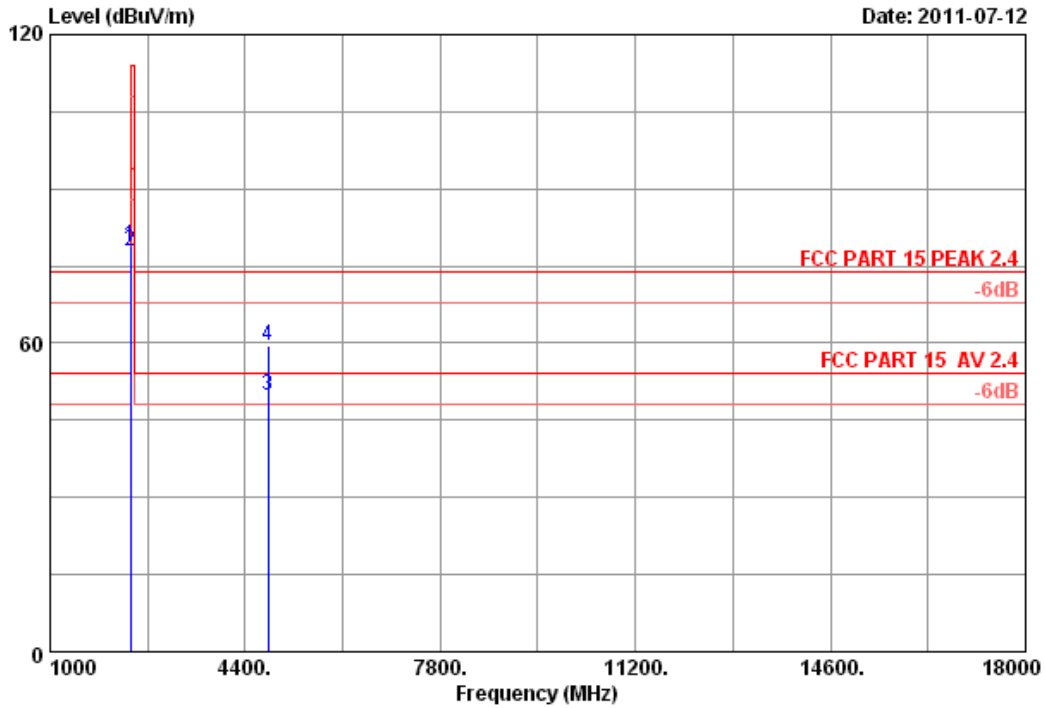

Site no. : 3# Chamber Data no. : 2
 Dis. / Ant. : 3m 3115(O911) Ant. pol. : VERTICAL
 Limit : FCC PART 15 PEAK 2.4
 Env. / Ins. : 23*C/54% Engineer : TaTa Chen
 EUT : Wireless Mouse
 Power : DC 1.5V
 Test mode : TX 2408
 M/N : M250R

	Ant. Freq. (MHz)	Ant. Factor (dB/m)	Cable loss (dB)	Amp. Factor (dB)	Emission Reading (dBuV)	Emission Level (dBuV/m)	Limits (dBuV/m)	Margin (dB)	Remark
1	2408.000	29.45	7.43	36.62	78.68	78.94	114.00	35.06	Peak
2	2408.000	29.45	7.43	36.62	77.60	77.86	94.00	16.14	Average
3	4816.000	34.30	10.62	35.10	40.14	49.96	54.00	4.04	Average
4	4816.000	34.30	10.62	35.10	49.74	59.56	74.00	14.44	Peak

Remarks:

1. Emission Level= Antenna Factor + Cable Loss -Amp Factor + Reading.
2. The emission levels that are 20dB below the official limit are not reported.

Data: 3 File: E:\2010 report data\J201110311.EM6 (34)

Date: 2011-07-12

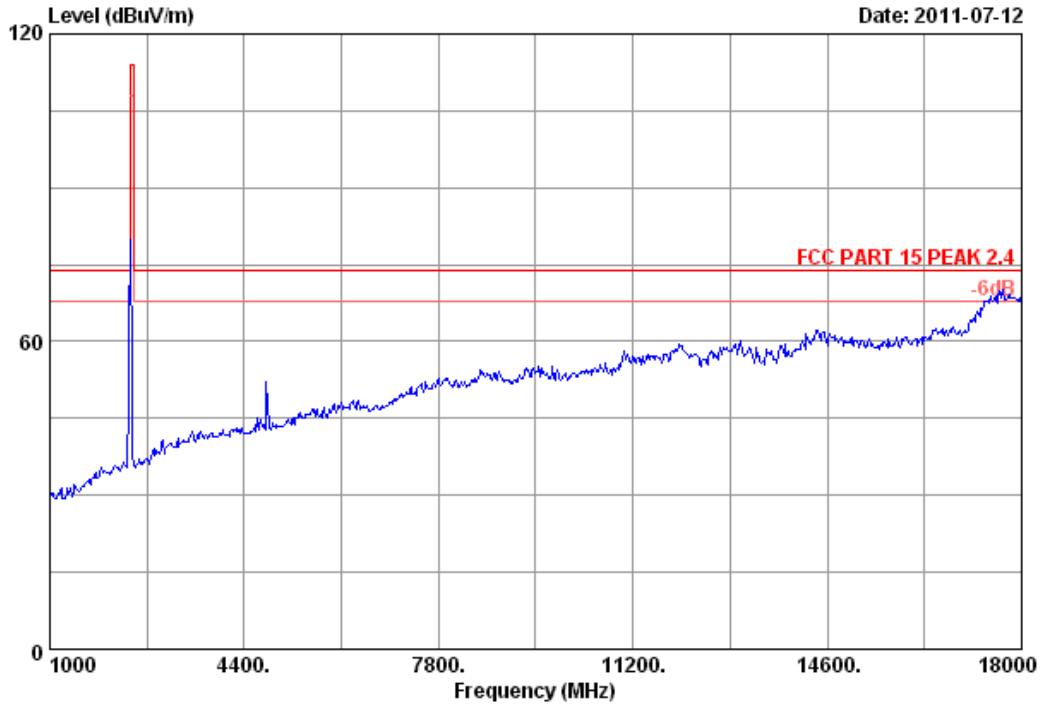

Site no.	: 3# Chamber	Data no. :	3
Dis. / Ant.	: 3m 3115(0911)	Ant. pol. :	HORIZONTAL
Limit	: FCC PART 15 PEAK 2.4		
Env. / Ins.	: 23°C/54%	Engineer :	TaTa Chen
EUT	: Wireless Mouse		
Power	: DC 1.5V		
Test mode	: TX 2408		
M/N	: M250R		



Data: 4 File: E:\2010 report data\J20110311.EM6 (34)

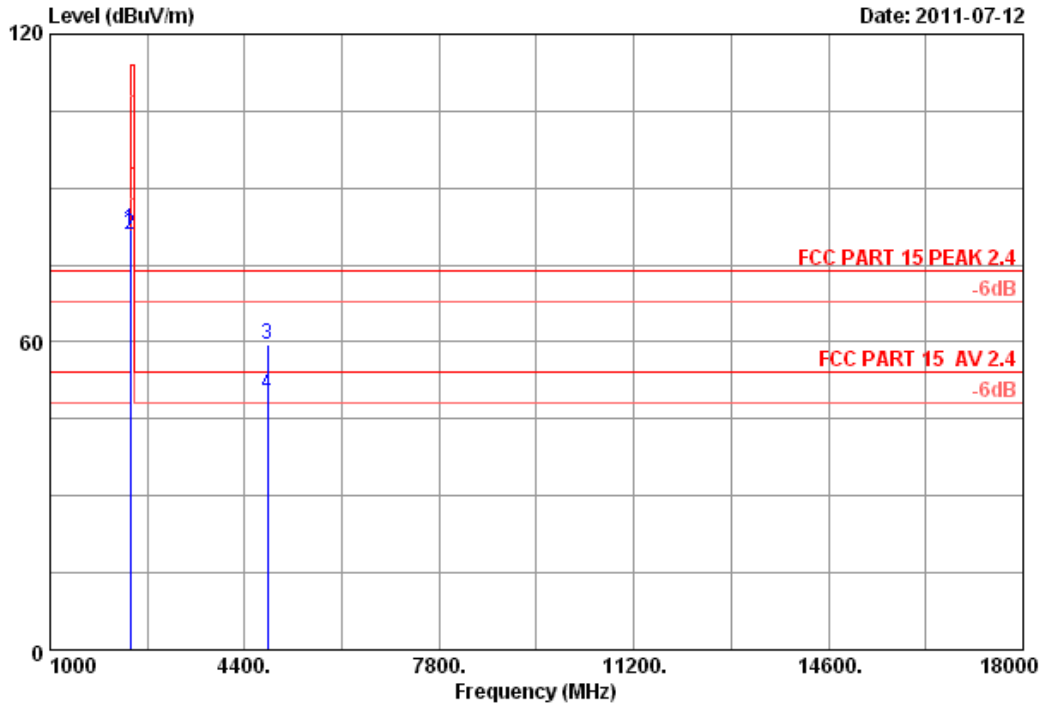

Site no. : 3# Chamber Data no. : 4
 Dis. / Ant. : 3m 3115(0911) Ant. pol. : HORIZONTAL
 Limit : FCC PART 15 PEAK 2.4
 Env. / Ins. : 23*C/54% Engineer : TaTa Chen
 EUT : Wireless Mouse
 Power : DC 1.5V
 Test mode : TX 2408
 M/N : M250R

	Freq. (MHz)	Ant. Factor (dB/m)	Cable loss (dB)	Amp. Factor (dB)	Reading (dBuV)	Emission Level (dBuV/m)	Limits (dBuV/m)	Margin (dB)	Remark
1	2408.000	29.45	7.43	36.62	81.71	81.97	114.00	32.03	Peak
2	2408.000	29.45	7.43	36.62	80.54	80.80	94.00	13.20	Average
3	4816.000	34.30	10.62	35.10	49.65	59.47	74.00	14.53	Peak
4	4816.000	34.30	10.62	35.10	40.12	49.94	54.00	4.06	Average

Remarks:

1. Emission Level= Antenna Factor + Cable Loss -Amp Factor + Reading.
2. The emission levels that are 20dB below the official limit are not reported.

Data: 7 File: E:\2010 report data\J20110311.EM6 (34)

Date: 2011-07-12

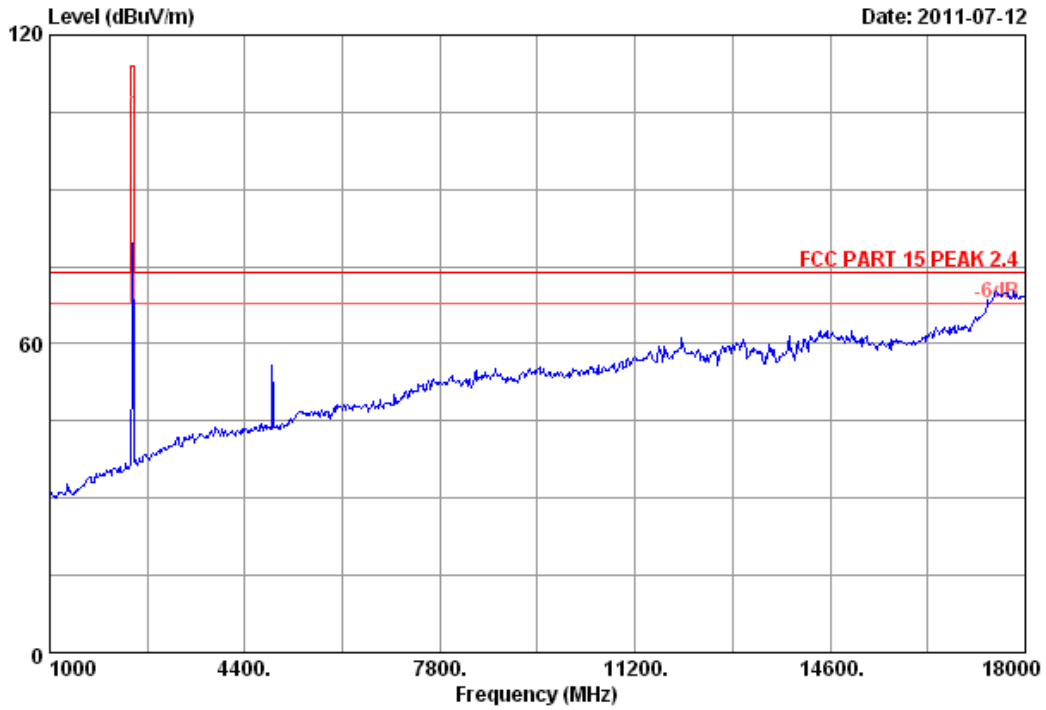

Site no.	: 3# Chamber	Data no. :	7
Dis. / Ant.	: 3m 3115(0911)	Ant. pol. :	VERTICAL
Limit	: FCC PART 15 PEAK 2.4		
Env. / Ins.	: 23°C/54%	Engineer :	TaTa Chen
EUT	: Wireless Mouse		
Power	: DC 1.5V		
Test mode	: TX 2440		
M/N	: M250R		



Data: 8 File: E:\2010 report data\J20110311.EM6 (34) Date: 2011-07-12

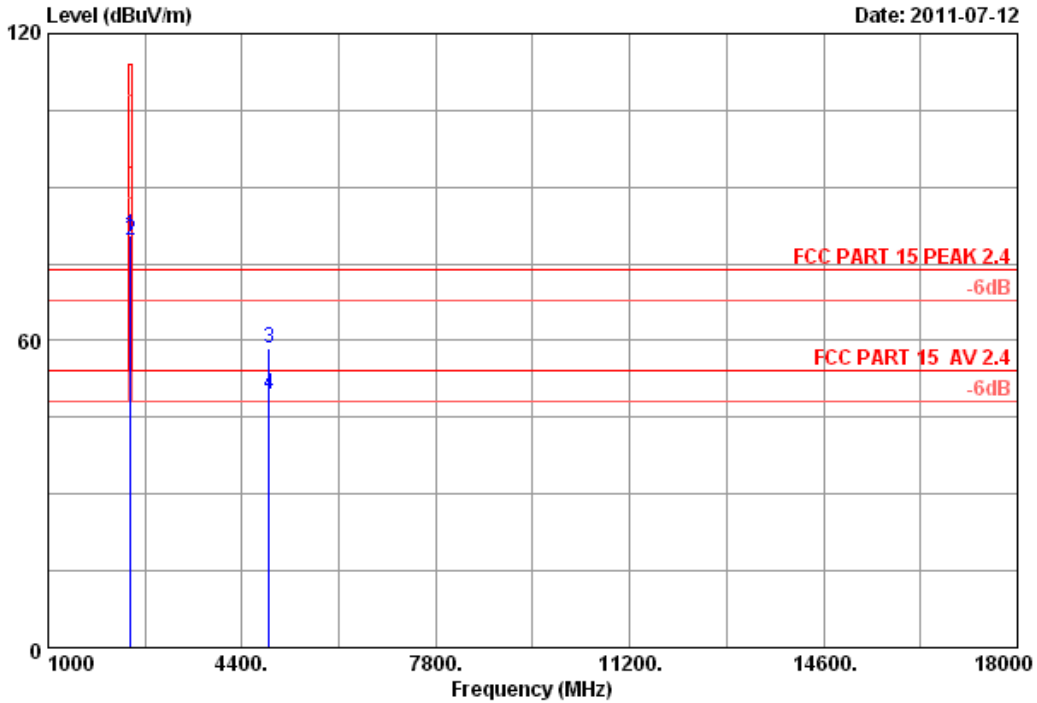

Site no. : 3# Chamber Data no. : 8
 Dis. / Ant. : 3m 3115(0911) Ant. pol. : VERTICAL
 Limit : FCC PART 15 PEAK 2.4
 Env. / Ins. : 23°C/54% Engineer : TaTa Chen
 EUT : Wireless Mouse
 Power : DC 1.5V
 Test mode : TX 2440
 M/N : M250R

	Ant. Freq. (MHz)	Ant. Factor (dB/m)	Cable loss (dB)	Amp. Factor (dB)	Emission Reading (dBuV)	Emission Level (dBuV/m)	Limits (dBuV/m)	Margin (dB)	Remark
1	2440.000	29.47	7.50	36.61	80.10	80.46	114.00	33.54	Peak
2	2440.000	29.47	7.50	36.61	79.21	79.57	94.00	14.43	Average
3	4880.000	34.41	10.71	35.03	48.38	58.47	74.00	15.53	Peak
4	4880.000	34.41	10.71	35.03	39.23	49.32	54.00	4.68	Average

Remarks:
 1. Emission Level= Antenna Factor + Cable Loss -Amp Factor + Reading.
 2. The emission levels that are 20dB below the official limit are not reported.

Data: 9 File: E:\2010 report data\J20110311.EM6 (34)

Date: 2011-07-12

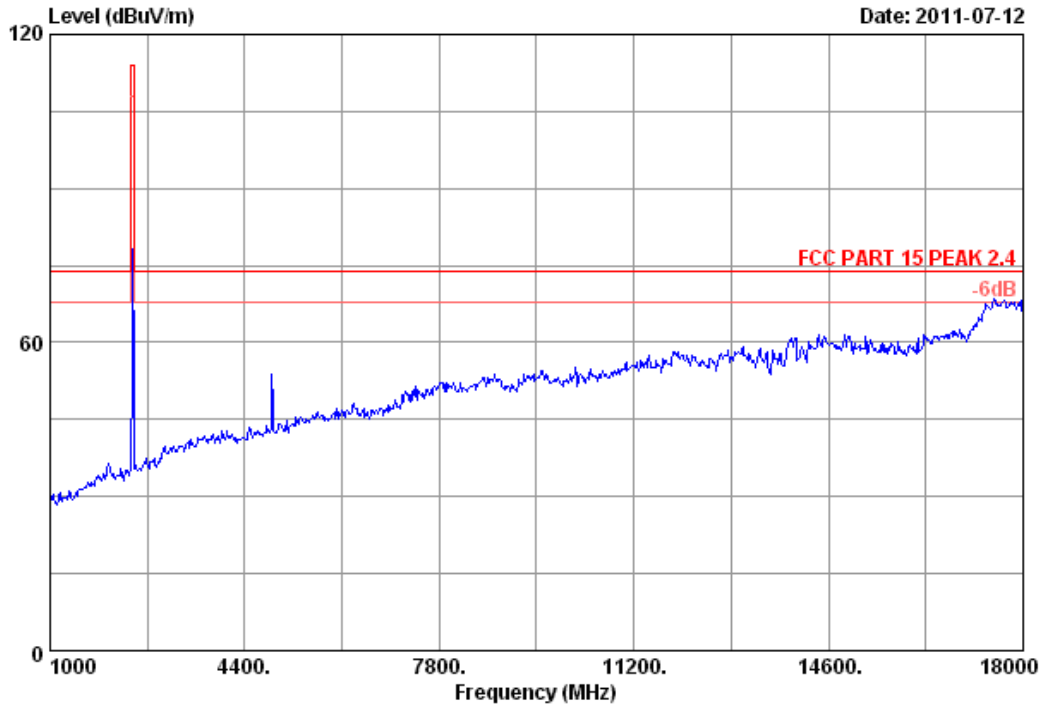

Site no.	: 3# Chamber	Data no.	: 9
Dis. / Ant.	: 3m 3115(0911)	Ant. pol.	: HORIZONTAL
Limit	: FCC PART 15 PEAK 2.4		
Env. / Ins.	: 23°C/54%	Engineer	: TaTa Chen
EUT	: Wireless Mouse		
Power	: DC 1.5V		
Test mode	: TX 2440		
M/N	: M250R		

Data: 10 File: E:\2010 report data\J201110311.EM6 (34)

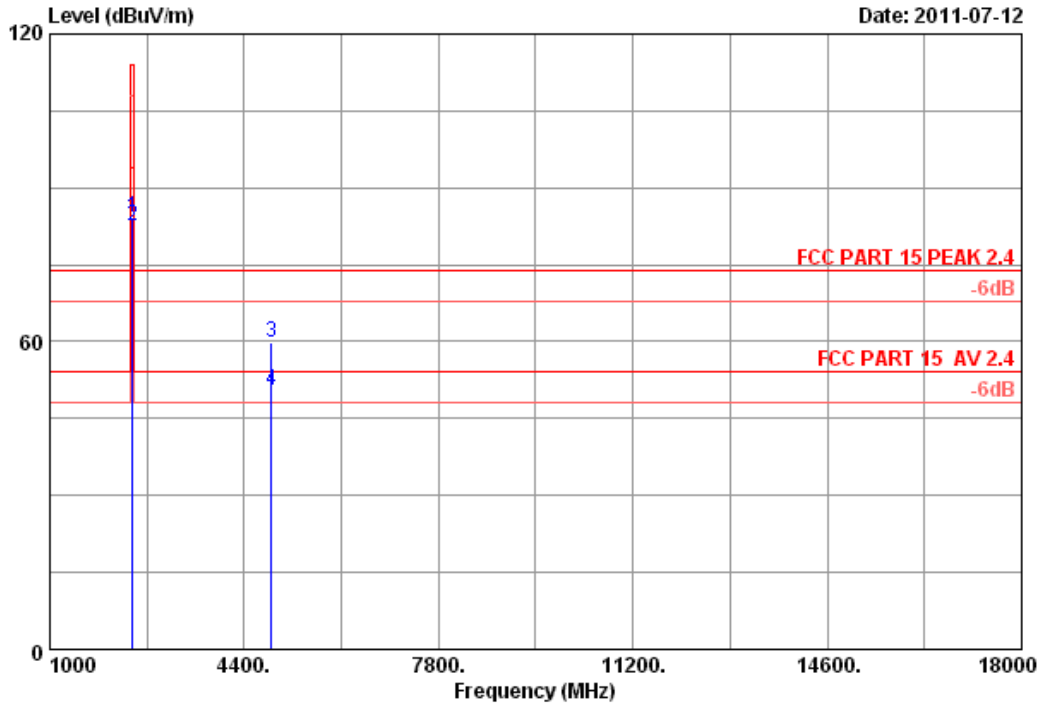

Site no. : 3# Chamber Data no. : 10
 Dis. / Ant. : 3m 3115(0911) Ant. pol. : HORIZONTAL
 Limit : FCC PART 15 PEAK 2.4
 Env. / Ins. : 23*C/54% Engineer : TaTa Chen
 EUT : Wireless Mouse
 Power : DC 1.5V
 Test mode : TX 2440
 M/N : M250R

	Freq. (MHz)	Ant. Factor (dB/m)	Cable loss (dB)	Amp. Factor (dB)	Reading (dBuV)	Emission Level (dBuV/m)	Limits (dBuV/m)	Margin (dB)	Remark
1	2440.000	29.47	7.50	36.61	83.76	84.12	114.00	29.88	Peak
2	2440.000	29.47	7.50	36.61	82.10	82.46	94.00	11.54	Average
3	4880.000	34.41	10.71	35.03	49.62	59.71	74.00	14.29	Peak
4	4880.000	34.41	10.71	35.03	40.36	50.45	54.00	3.55	Average

Remarks:

1. Emission Level= Antenna Factor + Cable Loss -Amp Factor + Reading.
2. The emission levels that are 20dB below the official limit are not reported.



Data: 11 File: E:\2010 report data\J201110311.EM6 (34)

Date: 2011-07-12

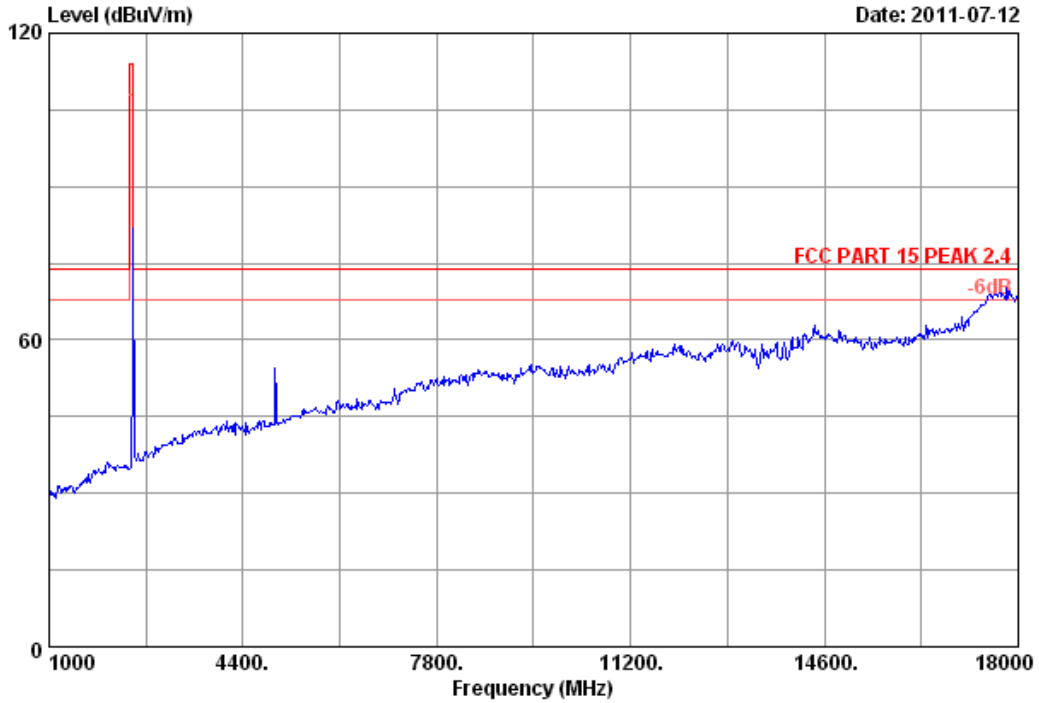

Site no.	: 3# Chamber	Data no. :	11
Dis. / Ant.	: 3m 3115(0911)	Ant. pol. :	HORIZONTAL
Limit	: FCC PART 15 PEAK 2.4		
Env. / Ins.	: 23°C/54%	Engineer :	TaTa Chen
EUT	: Wireless Mouse		
Power	: DC 1.5V		
Test mode	: TX 2474		
M/N	: M250R		

Data: 12 File: E:\2010 report data\J201110311.EM6 (34)

Date: 2011-07-12

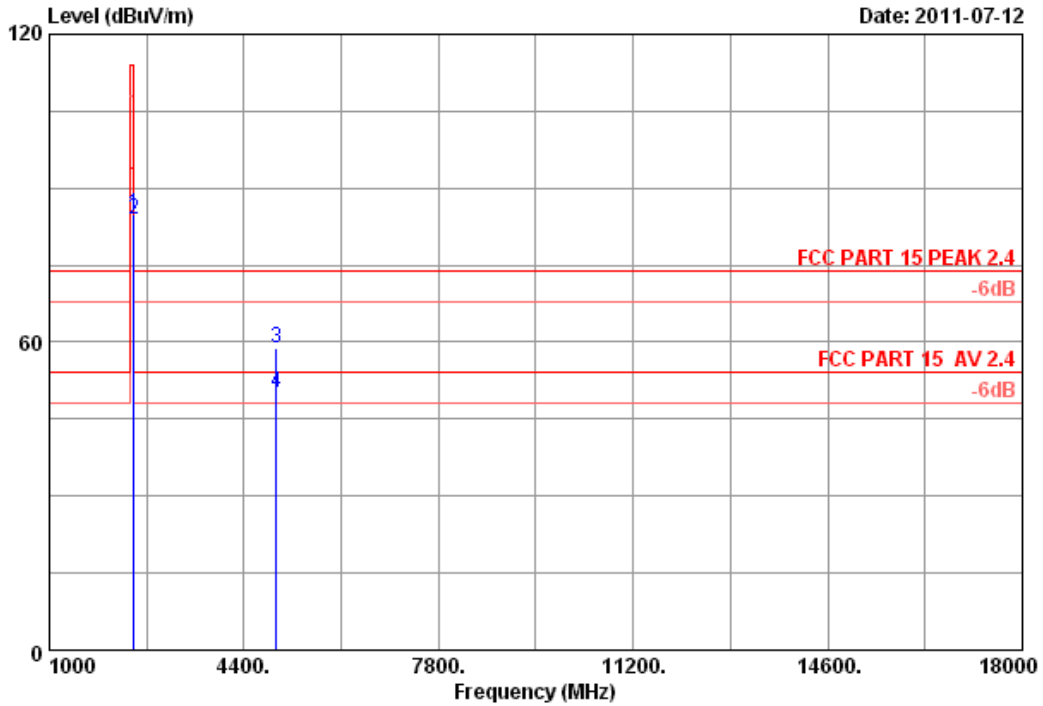

Site no. : 3# Chamber Data no. : 12
 Dis. / Ant. : 3m 3115(O911) Ant. pol. : HORIZONTAL
 Limit : FCC PART 15 PEAK 2.4
 Env. / Ins. : 23*C/54% Engineer : TaTa Chen
 EUT : Wireless Mouse
 Power : DC 1.5V
 Test mode : TX 2474
 M/N : M250R

	Freq. (MHz)	Ant. Factor (dB/m)	Cable loss (dB)	Amp. Factor (dB)	Reading (dBuV)	Emission Level (dBuV/m)	Limits (dBuV/m)	Margin (dB)	Remark
1	2474.000	29.49	7.58	36.60	84.51	84.98	114.00	29.02	Peak
2	2474.000	29.49	7.58	36.60	83.29	83.76	94.00	10.24	Average
3	4948.000	34.54	10.80	34.95	48.33	58.72	74.00	15.28	Peak
4	4948.000	34.54	10.80	34.95	39.66	50.05	54.00	3.95	Average

Remarks:

1. Emission Level= Antenna Factor + Cable Loss -Amp Factor + Reading.
2. The emission levels that are 20dB below the official limit are not reported.



Data: 13 File: E:\2010 report data\J20110311.EM6 (34)

Date: 2011-07-12

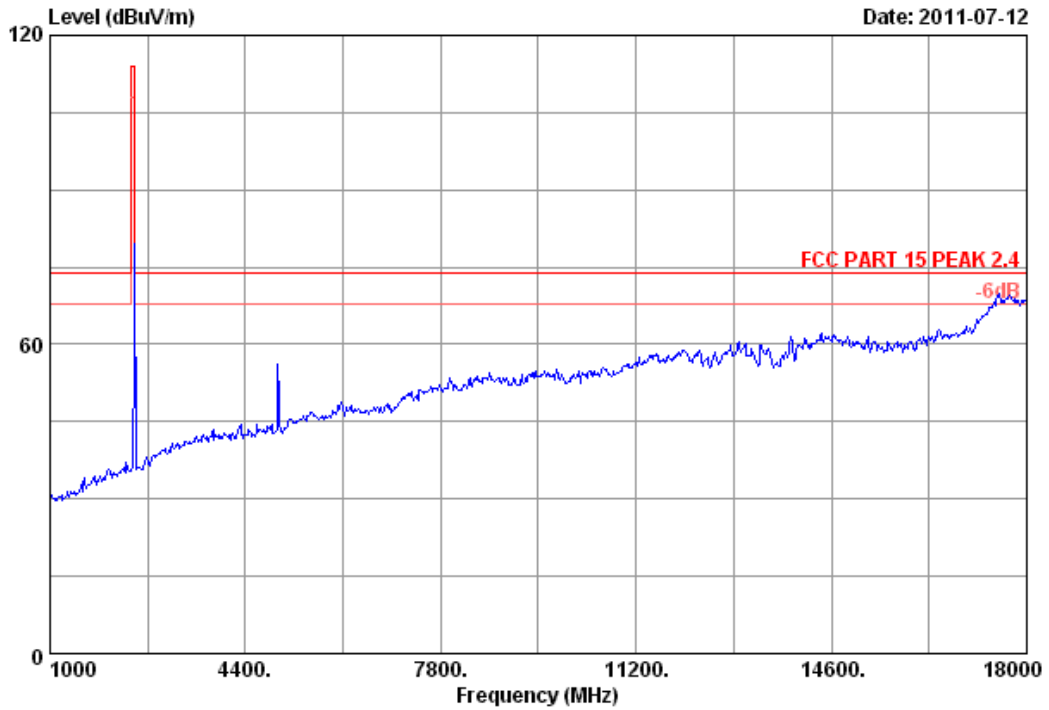

Site no.	: 3# Chamber	Data no. :	13
Dis. / Ant.	: 3m 3115(0911)	Ant. pol. :	VERTICAL
Limit	: FCC PART 15 PEAK 2.4	Engineer :	TaTa Chen
Env. / Ins.	: 23°C/54%		
EUT	: Wireless Mouse		
Power	: DC 1.5V		
Test mode	: TX 2474		
M/N	: M250R		



Data: 14 File: E:\2010 report data\J20110311.EM6 (34)

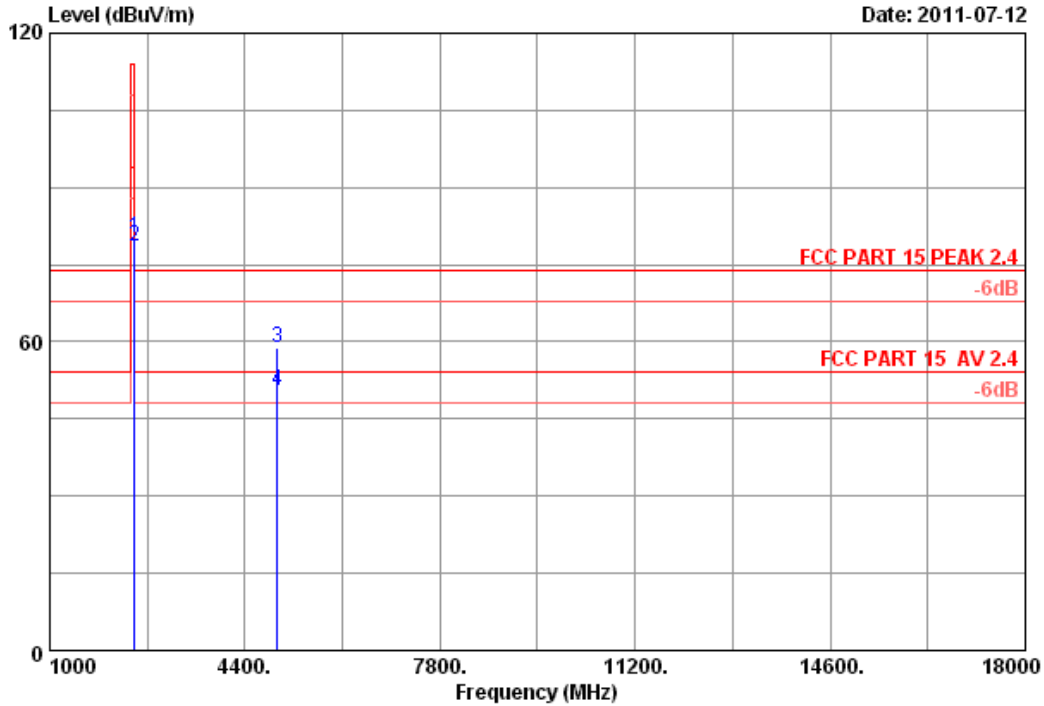

Site no. : 3# Chamber Data no. : 14
 Dis. / Ant. : 3m 3115(0911) Ant. pol. : VERTICAL
 Limit : FCC PART 15 PEAK 2.4
 Env. / Ins. : 23*C/54% Engineer : TaTa Chen
 EUT : Wireless Mouse
 Power : DC 1.5V
 Test mode : TX 2474
 M/N : M250R

	Ant. Freq. (MHz)	Ant. Factor (dB/m)	Cable loss (dB)	Amp. Factor (dB)	Reading (dBuV)	Emission Level (dBuV/m)	Limits (dBuV/m)	Margin (dB)	Remark
1	2474.000	29.49	7.58	36.60	79.72	80.19	114.00	33.81	Peak
2	2474.000	29.49	7.58	36.60	78.09	78.56	94.00	15.44	Average
3	4948.000	34.54	10.80	34.95	48.42	58.81	74.00	15.19	Peak
4	4948.000	34.54	10.80	34.95	40.21	50.60	54.00	3.40	Average

Remarks:

1. Emission Level= Antenna Factor + Cable Loss -Amp Factor + Reading.
2. The emission levels that are 20dB below the official limit are not reported.

Data: 17 File: E:\2010 report data\J20110311.EM6 (34)

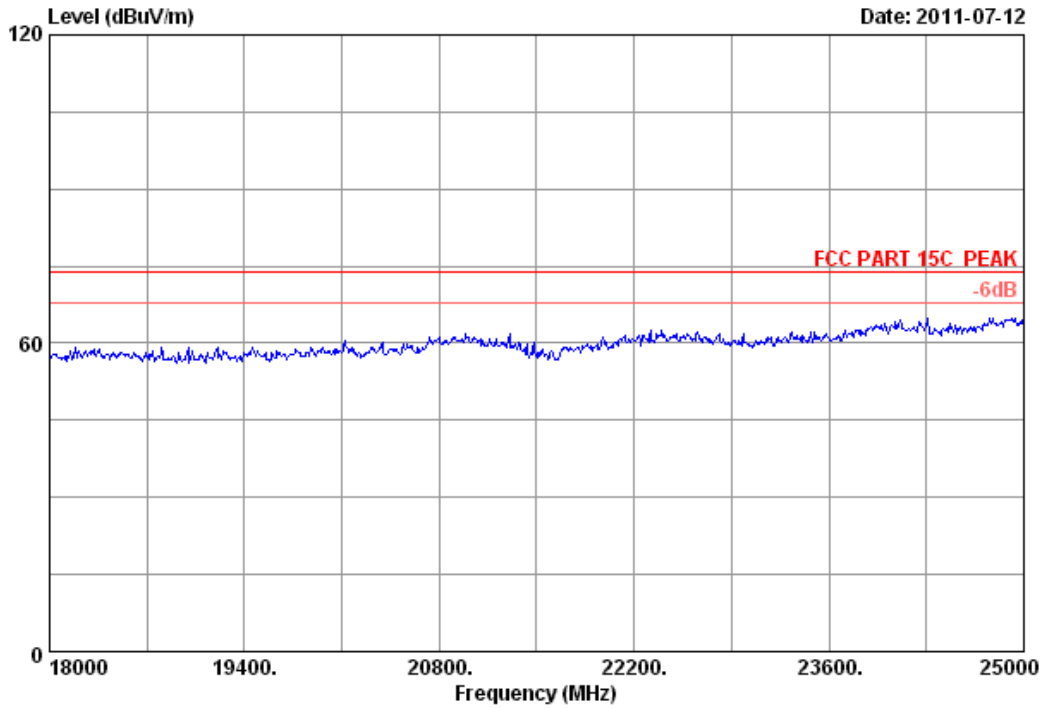

Site no.	: 3# Chamber	Data no. :	17
Dis. / Ant.	: 3m 3116 T	Ant. pol. :	HORIZONTAL
Limit	: FCC PART 15C PEAK		
Env. / Ins.	: 23°C/54%	Engineer :	TaTa Chen
EUT	: Wireless Mouse		
Power	: DC 1.5V		
Test mode	: TX 2474		
M/N	: M250R		

Data: 18 File: E:\2010 report data\J20110311.EM6 (34)

Date: 2011-07-12

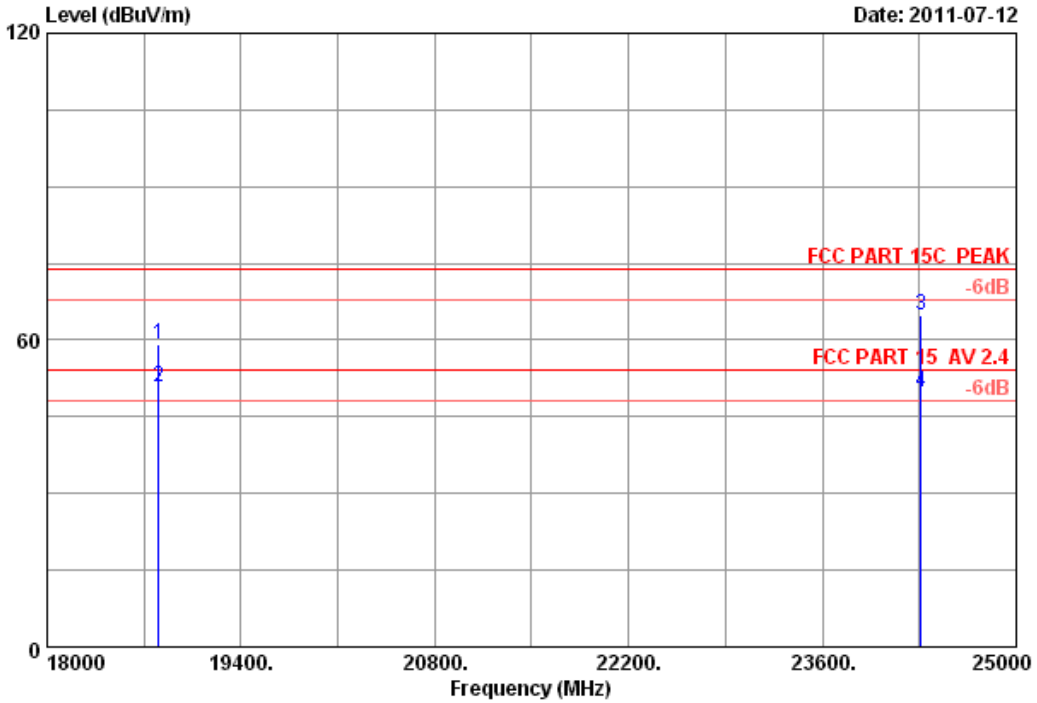

Site no. : 3# Chamber Data no. : 18
 Dis. / Ant. : 3m 3116 T Ant. pol. : HORIZONTAL
 Limit : FCC PART 15C PEAK
 Env. / Ins. : 23°C/54% Engineer : TaTa Chen
 EUT : Wireless Mouse
 Power : DC 1.5V
 Test mode : TX 2474
 M/N : M250R

	Ant. Freq. (MHz)	Ant. Factor (dB/m)	Cable loss (dB)	Amp. Factor (dB)	Emission Reading (dBuV)	Emission Level (dBuV/m)	Limits (dBuV/m)	Margin (dB)	Remark
1	18805.000	39.22	17.88	33.52	35.62	59.20	74.00	14.80	Peak
2	18805.000	39.22	17.88	33.52	27.26	50.84	54.00	3.16	Average
3	24314.000	39.66	20.07	34.06	39.18	64.85	74.00	9.15	Peak
4	24314.000	39.66	20.07	34.06	24.11	49.78	54.00	4.22	Average

Remarks:
 1. Emission Level= Antenna Factor + Cable Loss -Amp Factor + Reading.
 2. The emission levels that are 20dB below the official limit are not reported.



Data: 19 File: E:\2010 report data\J20110311.EM6 (34) Date: 2011-07-12

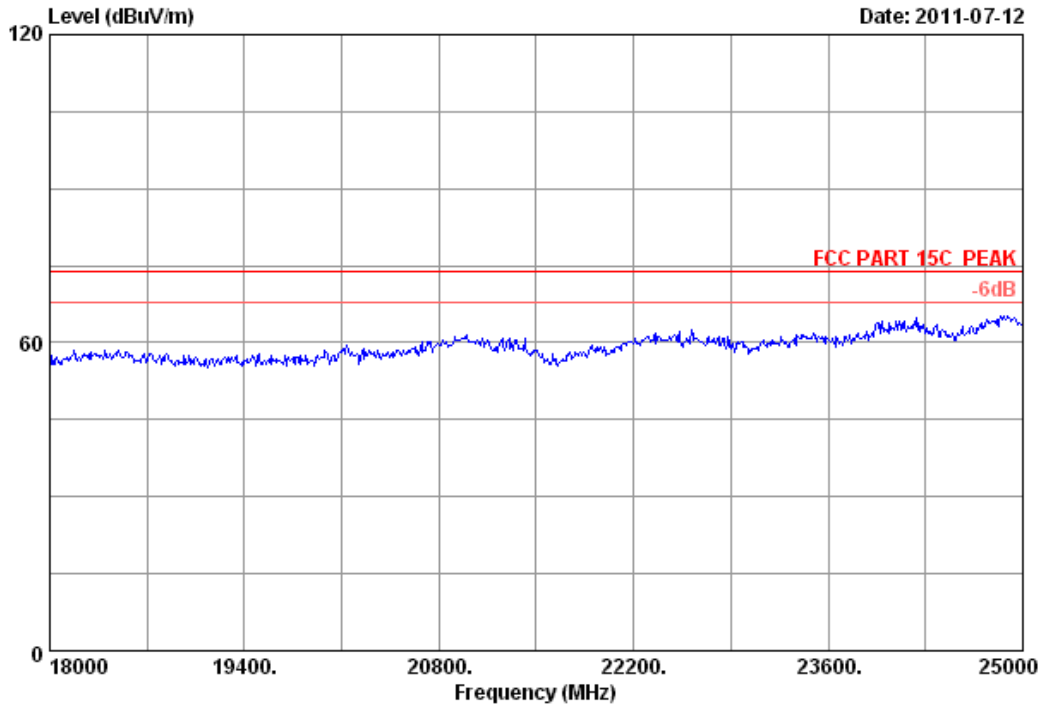

Site no.	: 3# Chamber	Data no. :	19
Dis. / Ant.	: 3m 3116 T	Ant. pol. :	VERTICAL
Limit	: FCC PART 15C PEAK		
Env. / Ins.	: 23°C/54%	Engineer :	TaTa Chen
EUT	: Wireless Mouse		
Power	: DC 1.5V		
Test mode	: TX 2474		
M/N	: M250R		

Data: 20 File: E:\2010 report data\J20110311.EM6 (34)

Date: 2011-07-12

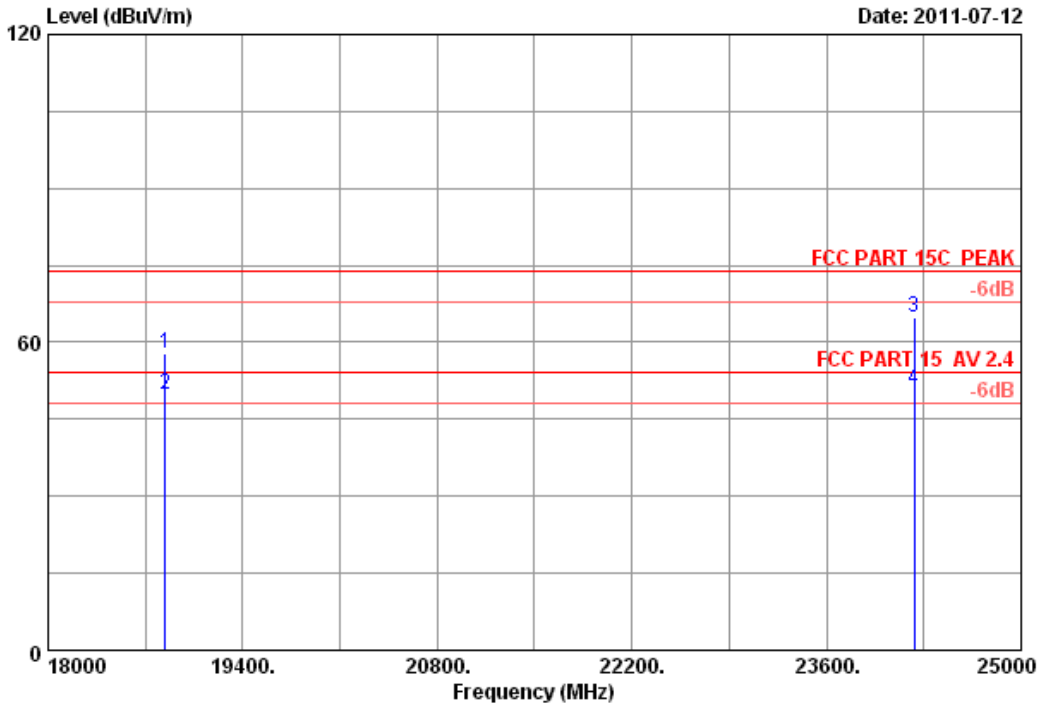

Site no. : 3# Chamber Data no. : 20
 Dis. / Ant. : 3m 3116 T Ant. pol. : VERTICAL
 Limit : FCC PART 15C PEAK
 Env. / Ins. : 23*C/54% Engineer : TaTa Chen
 EUT : Wireless Mouse
 Power : DC 1.5V
 Test mode : TX 2474
 M/N : M250R

	Ant. Freq. (MHz)	Ant. Factor (dB/m)	Cable loss (dB)	Amp. Factor (dB)	Reading (dBuV)	Emission Level (dBuV/m)	Limits (dBuV/m)	Margin (dB)	Remark
1	18840.000	39.24	17.89	33.64	34.43	57.92	74.00	16.08	Peak
2	18840.000	39.24	17.89	33.64	26.43	49.92	54.00	4.08	Average
3	24230.000	39.65	20.04	33.82	38.90	64.77	74.00	9.23	Peak
4	24230.000	39.65	20.04	33.82	25.00	50.87	54.00	3.13	Average

Remarks:

1. Emission Level= Antenna Factor + Cable Loss -Amp Factor + Reading.
2. The emission levels that are 20dB below the official limit are not reported.



Data: 21 File: E:\2010 report data\J\20110311.EM6 (34)

Date: 2011-07-12

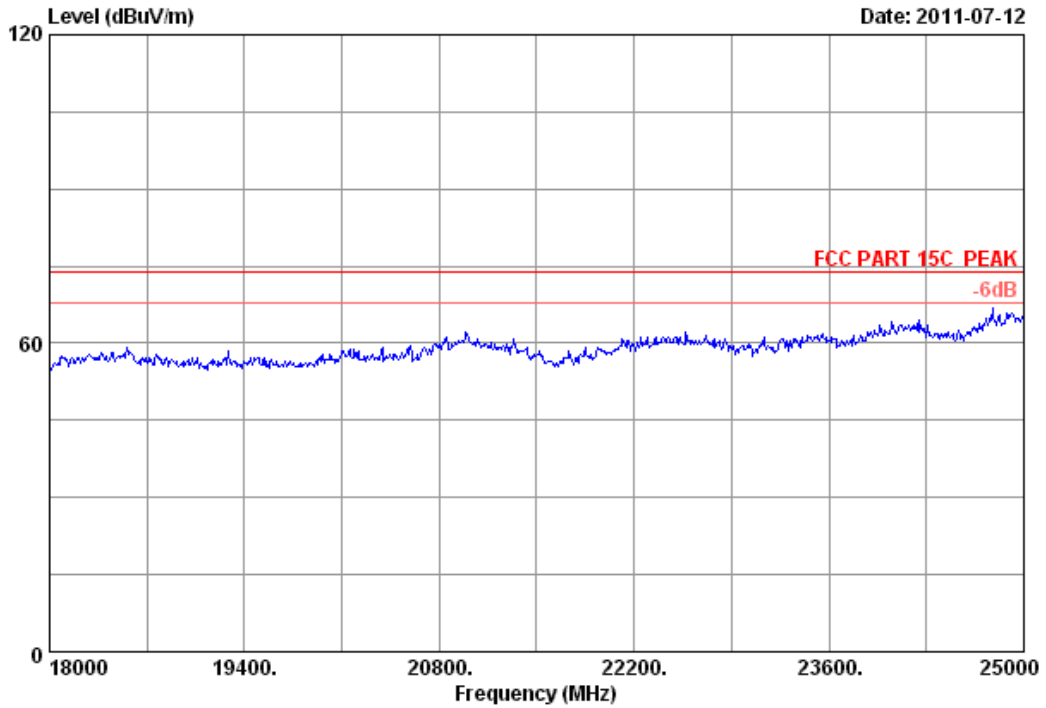

Site no.	: 3# Chamber	Data no. :	21
Dis. / Ant.	: 3m 3116 T	Ant. pol. :	VERTICAL
Limit	: FCC PART 15C PEAK		
Env. / Ins.	: 23*C/54%	Engineer :	TaTa Chen
EUT	: Wireless Mouse		
Power	: DC 1.5V		
Test mode	: TX 2440		
M/N	: M250R		

Data: 22 File: E:\2010 report data\J20110311.EM6 (34)

Date: 2011-07-12

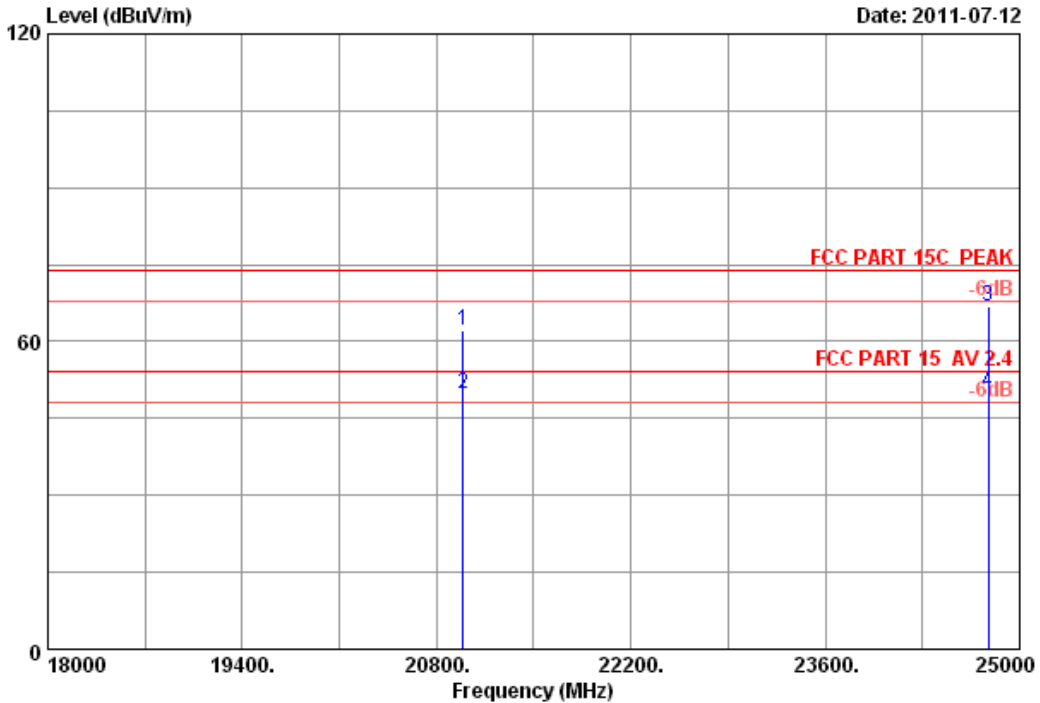

Site no. : 3# Chamber Data no. : 22
 Dis. / Ant. : 3m 3116 T Ant. pol. : VERTICAL
 Limit : FCC PART 15C PEAK
 Env. / Ins. : 23°C/54% Engineer : TaTa Chen
 EUT : Wireless Mouse
 Power : DC 1.5V
 Test mode : TX 2440
 M/N : M250R

	Ant. Freq. (MHz)	Ant. Factor (dB/m)	Cable loss (dB)	Amp. Factor (dB)	Reading (dBuV)	Emission Level (dBuV/m)	Limits (dBuV/m)	Margin (dB)	Remark
1	20989.000	40.30	18.75	33.40	36.49	62.14	74.00	11.86	Peak
2	20989.000	40.30	18.75	33.40	24.12	49.77	54.00	4.23	Average
3	24776.000	39.93	20.26	33.65	40.24	66.78	74.00	7.22	Peak
4	24776.000	39.93	20.26	33.65	23.56	50.10	54.00	3.90	Average

Remarks:

1. Emission Level= Antenna Factor + Cable Loss -Amp Factor + Reading.
2. The emission levels that are 20dB below the official limit are not reported.



Data: 23 File: E:\2010 report data\J\20110311.EM6 (34) Date: 2011-07-12

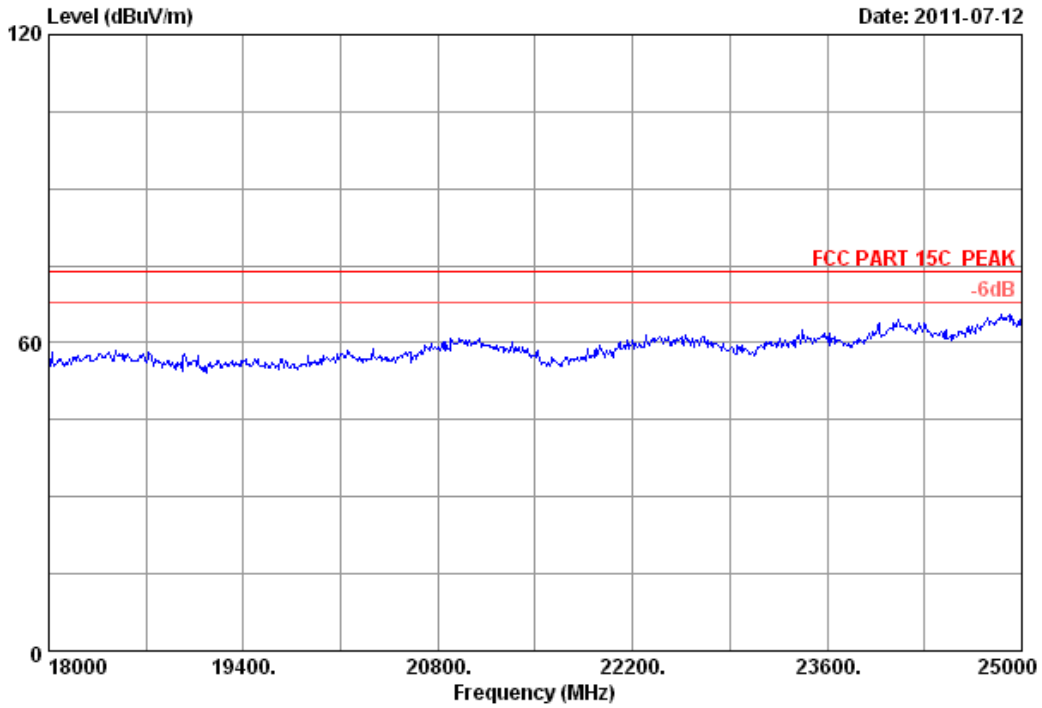

Site no.	: 3# Chamber	Data no. :	23
Dis. / Ant.	: 3m 3116 T	Ant. pol. :	HORIZONTAL
Limit	: FCC PART 15C PEAK		
Env. / Ins.	: 23°C/54%	Engineer :	TaTa Chen
EUT	: Wireless Mouse		
Power	: DC 1.5V		
Test mode	: TX 2440		
M/N	: M250R		

Data: 24 File: E:\2010 report data\J20110311.EM6 (34)

Date: 2011-07-12

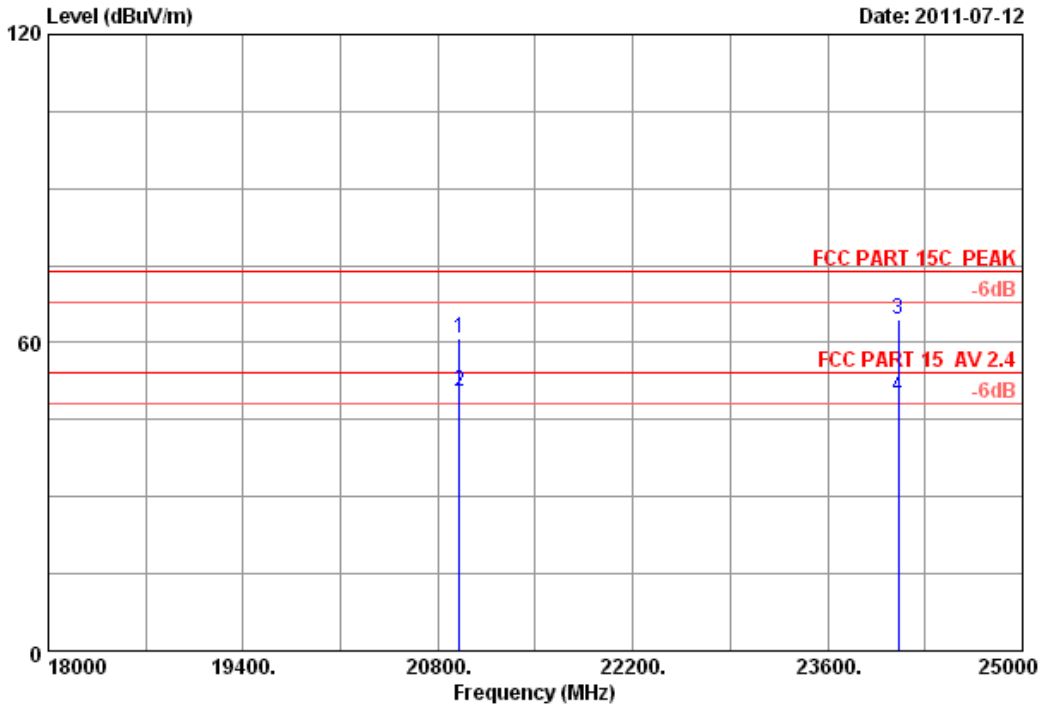

Site no. : 3# Chamber Data no. : 24
 Dis. / Ant. : 3m 3116 T Ant. pol. : HORIZONTAL
 Limit : FCC PART 15C PEAK
 Env. / Ins. : 23°C/54% Engineer : TaTa Chen
 EUT : Wireless Mouse
 Power : DC 1.5V
 Test mode : TX 2440
 M/N : M250R

	Ant. Freq. (MHz)	Factor (dB/m)	Cable loss (dB)	Amp. Factor (dB)	Reading (dBuV)	Emission Level (dBuV/m)	Limits (dBuV/m)	Margin (dB)	Remark
1	20954.000	40.27	18.73	33.49	35.34	60.85	74.00	13.15	Peak
2	20954.000	40.27	18.73	33.49	25.13	50.64	54.00	3.36	Average
3	24111.000	39.62	20.00	33.42	38.31	64.51	74.00	9.49	Peak
4	24111.000	39.62	20.00	33.42	23.33	49.53	54.00	4.47	Average

Remarks:

1. Emission Level= Antenna Factor + Cable Loss -Amp Factor + Reading.
2. The emission levels that are 20dB below the official limit are not reported.



Data: 25 File: E:\2010 report data\J\201110311.EM6 (34) Date: 2011-07-12

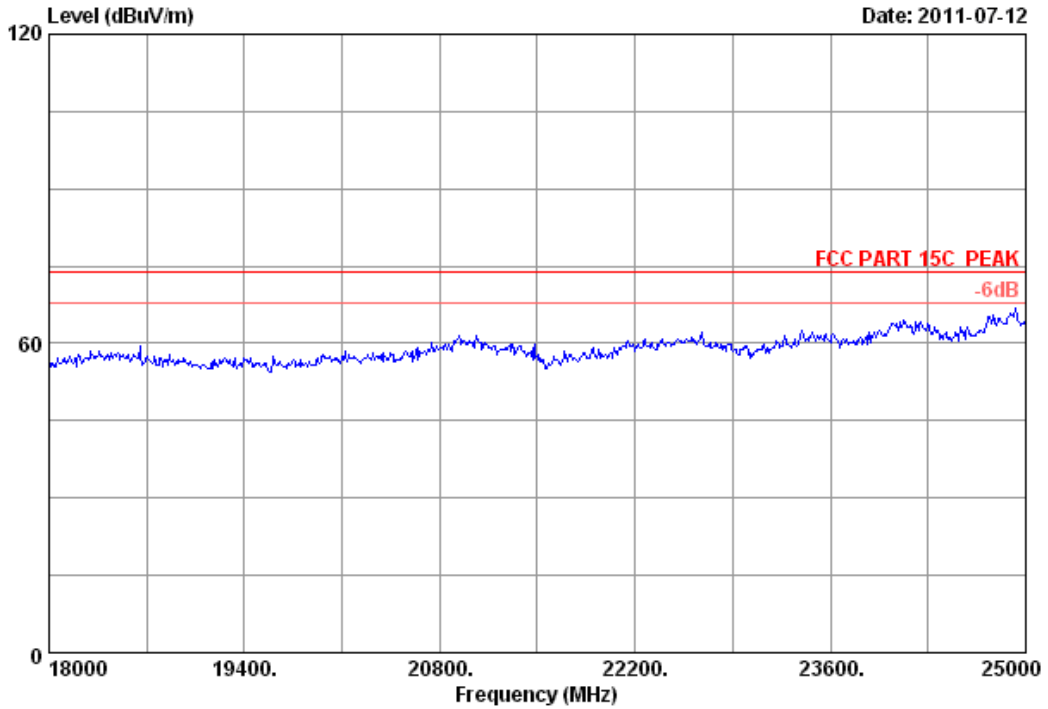

Site no.	: 3# Chamber	Data no.	: 25
Dis. / Ant.	: 3m 3116 T	Ant. pol.	: HORIZONTAL
Limit	: FCC PART 15C PEAK		
Env. / Ins.	: 23*C/54%	Engineer	: TaTa Chen
EUT	: Wireless Mouse		
Power	: DC 1.5V		
Test mode	: TX 2408		
M/N	: M250R		



Data: 26 File: E:\2010 report data\J\201110311.EM6 (34) Date: 2011-07-12

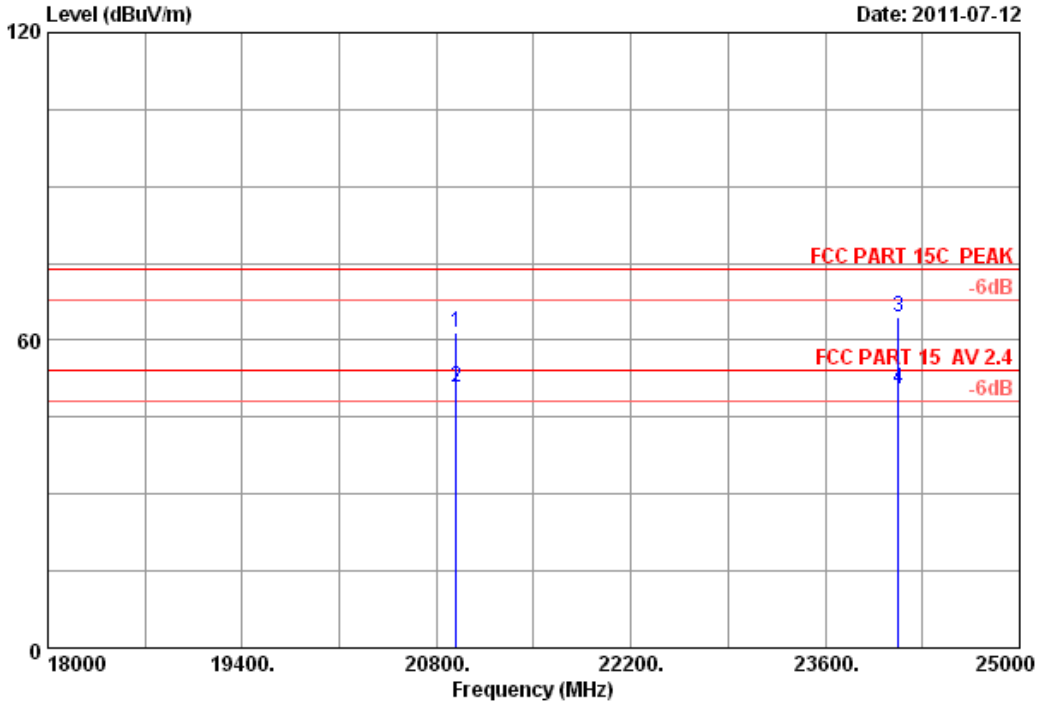

Site no. : 3# Chamber Data no. : 26
 Dis. / Ant. : 3m 3116 T Ant. pol. : HORIZONTAL
 Limit : FCC PART 15C PEAK
 Env. / Ins. : 23°C/54% Engineer : TaTa Chen
 EUT : Wireless Mouse
 Power : DC 1.5V
 Test mode : TX 2408
 M/N : M250R

	Ant. Freq. (MHz)	Ant. Factor (dB/m)	Cable loss (dB)	Amp. Factor (dB)	Reading (dBuV)	Emission Level (dBuV/m)	Limits (dBuV/m)	Margin (dB)	Remark
1	20940.000	40.27	18.73	33.58	36.05	61.47	74.00	12.53	Peak
2	20940.000	40.27	18.73	33.58	25.37	50.79	54.00	3.21	Average
3	24125.000	39.62	20.00	33.50	38.45	64.57	74.00	9.43	Peak
4	24125.000	39.62	20.00	33.50	24.23	50.35	54.00	3.65	Average

Remarks:

1. Emission Level= Antenna Factor + Cable Loss -Amp Factor + Reading.
2. The emission levels that are 20dB below the official limit are not reported.

Data: 27 File: E:\2010 report data\J\20110311.EM6 (34)

Date: 2011-07-12

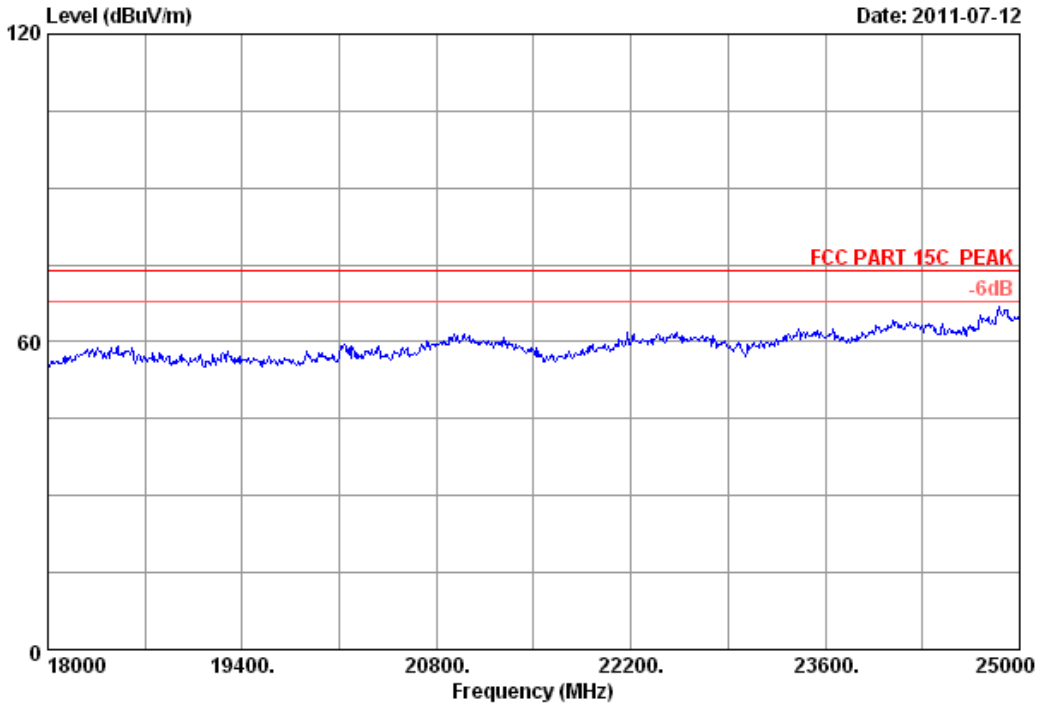

Site no.	: 3# Chamber	Data no. :	27
Dis. / Ant.	: 3m 3116 T	Ant. pol. :	VERTICAL
Limit	: FCC PART 15C PEAK		
Env. / Ins.	: 23°C/54%	Engineer :	TaTa Chen
EUT	: Wireless Mouse		
Power	: DC 1.5V		
Test mode	: TX 2408		
M/N	: M250R		

Data: 28 File: E:\2010 report data\J20110311.EM6 (34)

Date: 2011-07-12

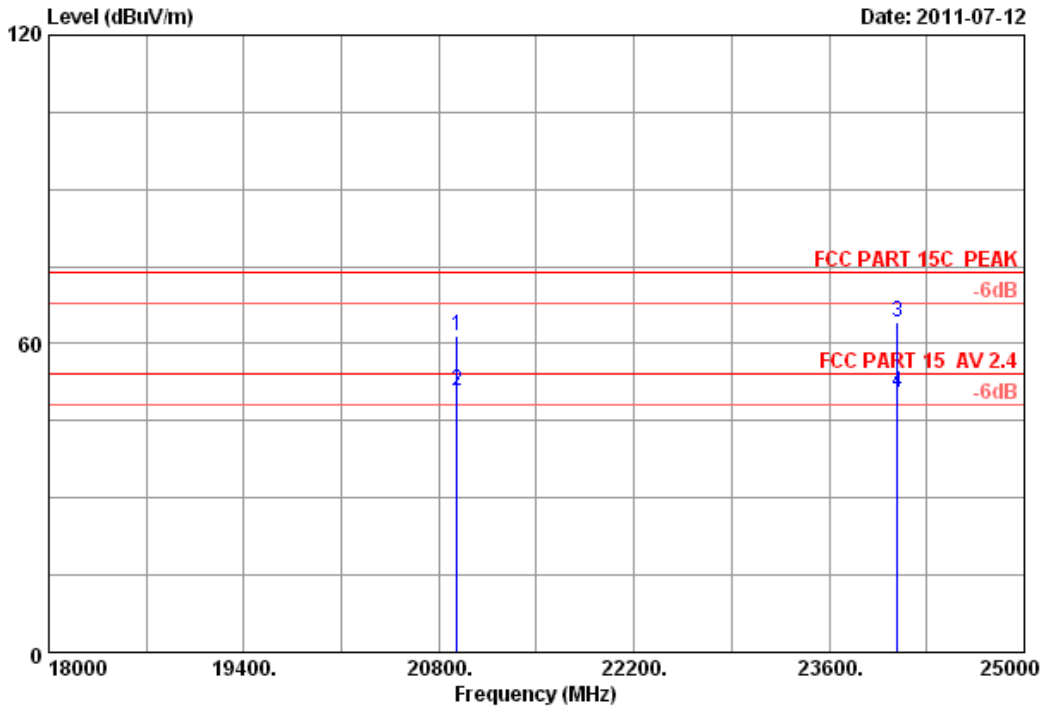

Site no. : 3# Chamber Data no. : 28
 Dis. / Ant. : 3m 3116 T Ant. pol. : VERTICAL
 Limit : FCC PART 15C PEAK
 Env. / Ins. : 23°C/54% Engineer : TaTa Chen
 EUT : Wireless Mouse
 Power : DC 1.5V
 Test mode : TX 2408
 M/N : M250R

	Ant. Freq. (MHz)	Ant. Factor (dB/m)	Cable loss (dB)	Amp. Factor (dB)	Reading (dBuV)	Emission Level (dBuV/m)	Limits (dBuV/m)	Margin (dB)	Remark
1	20926.000	40.26	18.73	33.67	36.29	61.61	74.00	12.39	Peak
2	20926.000	40.26	18.73	33.67	25.36	50.68	54.00	3.32	Average
3	24090.000	39.62	19.99	33.34	38.00	64.27	74.00	9.73	Peak
4	24090.000	39.62	19.99	33.34	24.22	50.49	54.00	3.51	Average

Remarks:

1. Emission Level= Antenna Factor + Cable Loss -Amp Factor + Reading.
2. The emission levels that are 20dB below the official limit are not reported.



5. 20 DB BANDWIDTH TEST

5.1. Test Equipment

Item	Equipment	Manufacturer	Model No.	Serial No.	Last Cal.	Cal. Interval
1.	Spectrum Analyz	Rohde &Schwarz	FSP	101130	Jun 17.11	1 Year

5.2. Limit

Intentional radiators operating under the alternative provisions to the general emission limits, as contained in §§ 15.217 through 15.257 and in Subpart E of this part, must be designed to ensure that the 20 dB bandwidth of the emission, or whatever bandwidth may otherwise be specified in the specific rule section under which the equipment operates, is contained within the frequency band designated in the rule section under which the equipment is operated.

5.3. Test Results

EUT: Wireless Mouse		
M/N: M250R		
Test date:2011-07-12	Pressure:101.4 kpa	Humidity:57 %
Tested by: TaTa Chen	Test site: RF site	Temperature : 24.1 °C

Frequency	20% bandwidth (MHz)	Limit (KHz)
2408	2.50	N/A
2440	2.50	N/A
2474	2.46	N/A
Conclusion : PASS		

Test Frequency: 2408MHz



*RBW 100 kHz Delta 2 [T1]
*VBW 300 kHz -20.43 dB
*SWT 500 ms 780.00000000 kHz

Ref 0 dBm Att 30 dB

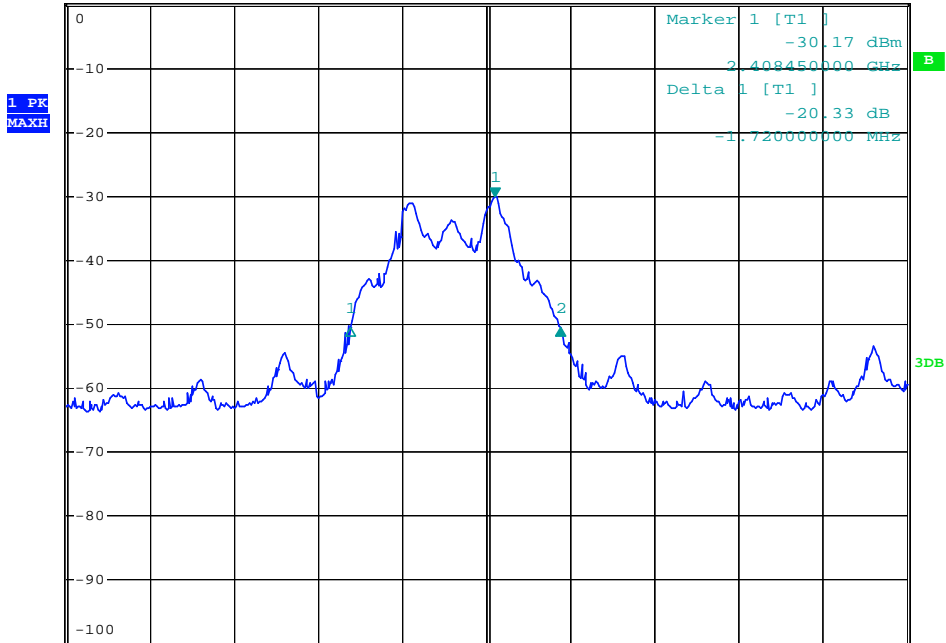

Date: 14.JUL.2011 06:27:04

Test Frequency: 2440MHz



*RBW 100 kHz Delta 1 [T1]
*VBW 300 kHz -21.42 dB
*SWT 500 ms -1.740000000 MHz

Ref 0 dBm Att 30 dB

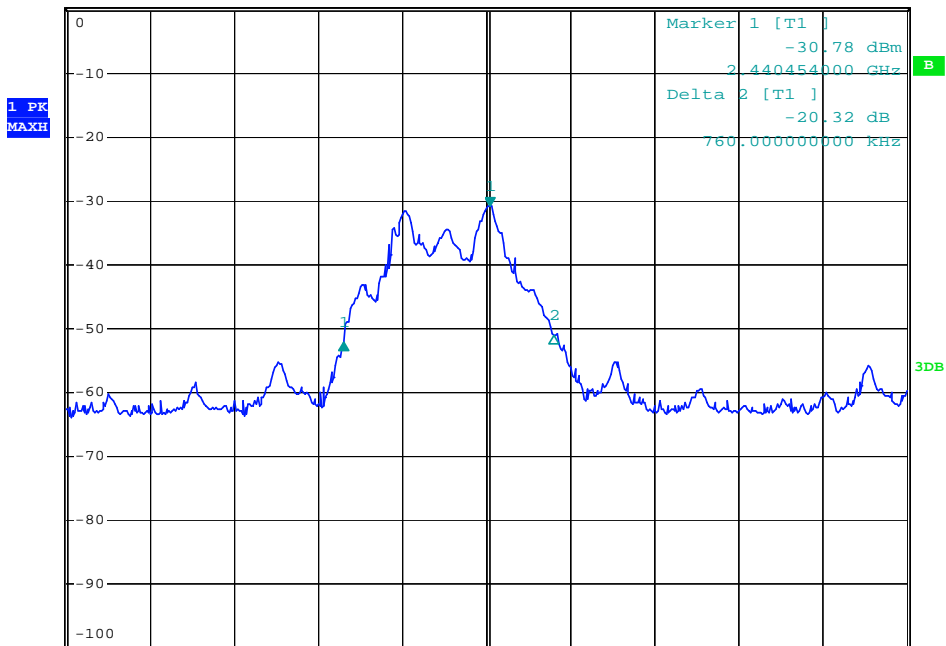

Date: 14.JUL.2011 06:29:05

Test Frequency: 2474MHz



*RBW 100 kHz Delta 1 [T1]
*VBW 300 kHz -20.83 dB
SWT 500 ms -1.720000000 MHz

Ref 0 dBm *Att 30 dB

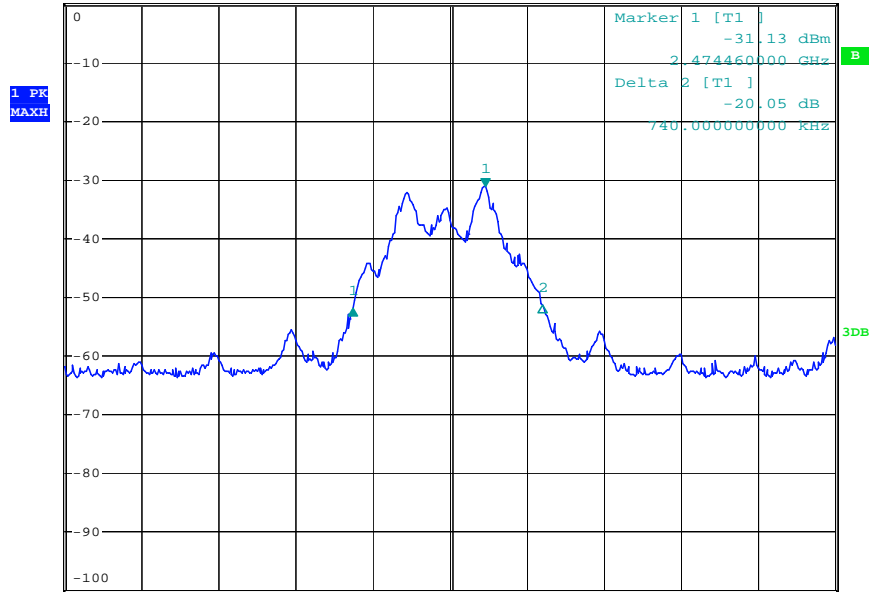

Date: 14.JUL.2011 06:36:09

6. BAND EDGE COMPLIANCE TEST

6.1. Test Equipment

Item	Equipment	Manufacturer	Model No.	Serial No.	Last Cal.	Cal. Interval
1.	Spectrum Analyzer	Agilent	E4446A	US44300459	May.08,11	1 Year
2.	Horn Antenna	EMCO	3115	9607-4877	Nov.25, 11	1.5 Year
3.	Amplifier	Agilent	8449B	3008A02495	May.08, 11	1 Year
4.	RF Cable	Hubersuhner	SUCOFLEX102	28620/2	May.08,11	1 Year
5.	RF Cable	Hubersuhner	SUCOFLEX102	28618/2	May.08,11	1 Year
6.	RF Cable	Hubersuhner	SUCOFLEX102	28610/2	May.08,11	1 Year

6.2. Limit

All the lower and upper band-edges emissions appearing within 2310MHz to 2390MHz and 2483.5MHz to 2500MHz restricted frequency bands shall not exceed the limits shown in 15.209, all the other emissions outside operation frequency band 2400MHz to 2483.5MHz shall be at least 20dB below the fundamental emissions, or comply with 15.209 limits.

6.3. Test Produce

1. The EUT is placed on a turntable, which is 0.8m above the ground plane and worked at highest radiated power.
2. The turntable was rotated for 360 degrees to determine the position of maximum emission level.
3. EUT is set 3m away from the receiving antenna, which is varied from 1m to 4m to find out the highest emission.
4. Set the spectrum analyzer in the following setting in order to capture the lower and upperband-edges of the emission:
 - (a) PEAK: RBW=1MHz ;VBW=3MHz, PK detector, Sweep=AUTO
 - (b) Average: RBW=1MHz ;VBW=10Hz, PK detector, Sweep=AUTO

6.4. Test Results

Pass (The testing data was attached in the next pages.)

Note: If the PK measured levels comply with average limit, then the average level were deemed to comply with average limit.

Data: 5 File: E:\2010 report data\J20110311.EM6 (34)

Date: 2011-07-12

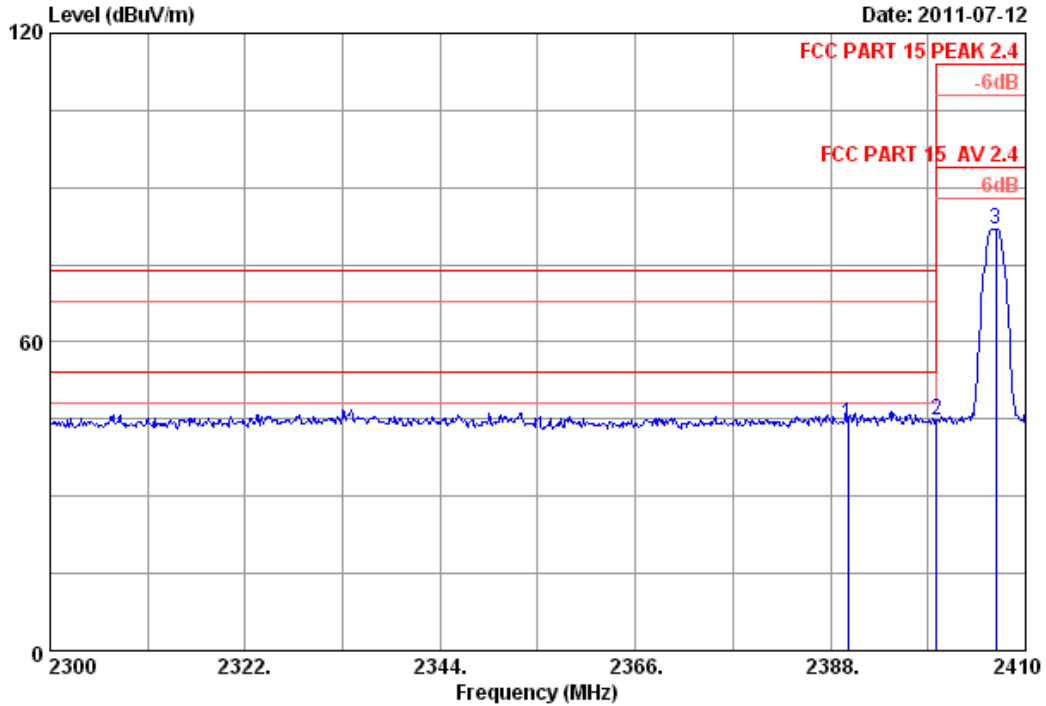

Site no.	: 3# Chamber	Data no.	: 5
Dis. / Ant.	: 3m 3115(0911)	Ant. pol.	: HORIZONTAL
Limit	: FCC PART 15 PEAK 2.4	Engineer	: TaTa Chen
Env. / Ins.	: 23°C/54%		
EUT	: Wireless Mouse		
Power	: DC 1.5V		
Test mode	: TX 2408		
M/N	: M250R		

	Ant. Freq. (MHz)	Ant. Factor (dB/m)	Cable loss (dB)	Amp. Factor (dB)	Reading (dBuV)	Emission Level (dBuV/m)	Limits (dBuV/m)	Margin (dB)	Remark
1	2390.000	29.44	7.39	36.62	44.06	44.27	74.00	29.73	Peak
2	2400.000	29.44	7.43	36.62	44.55	44.80	74.00	29.20	Peak
3	2407.180	29.45	7.43	36.62	81.68	81.94	114.00	32.06	Peak

Remarks:

1. Emission Level= Antenna Factor + Cable Loss -Amp Factor + Reading.
2. The emission levels that are 20dB below the official limit are not reported.

Data: 6 File: E:\2010 report data\J20110311.EM6 (34)

Date: 2011-07-12

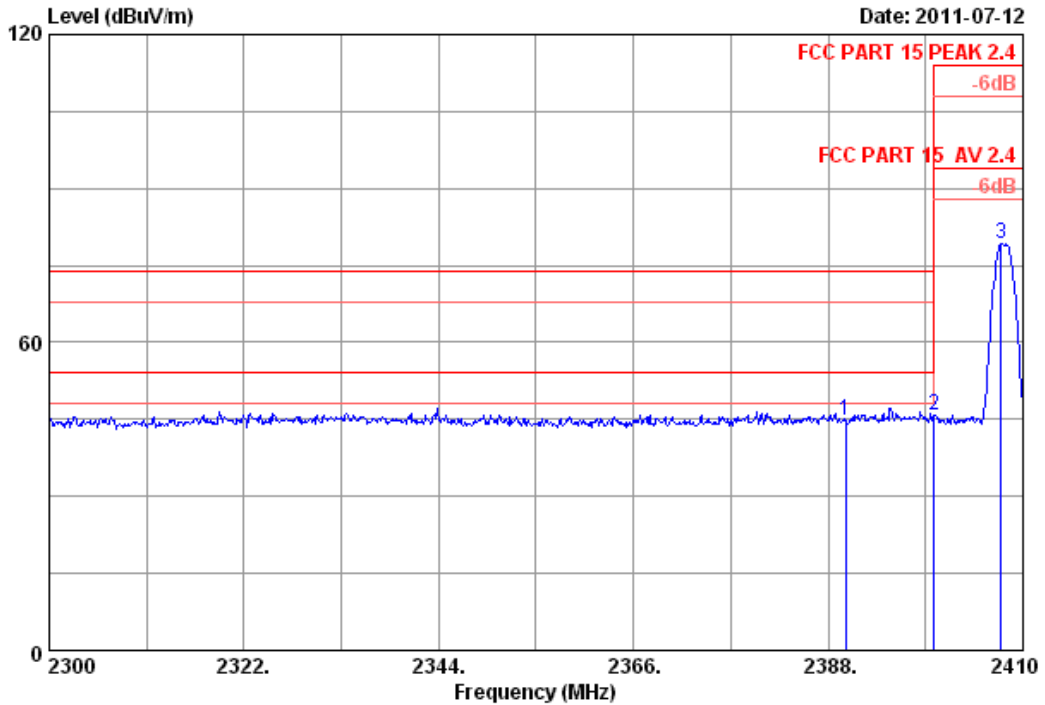

Site no. : 3# Chamber Data no. : 6
 Dis. / Ant. : 3m 3115(0911) Ant. pol. : VERTICAL
 Limit : FCC PART 15 PEAK 2.4
 Env. / Ins. : 23°C/54% Engineer : TaTa Chen
 EUT : Wireless Mouse
 Power : DC 1.5V
 Test mode : TX 2408
 M/N : M250R

	Ant. Freq. (MHz)	Ant. Factor (dB/m)	Cable loss (dB)	Amp. Factor (dB)	Emission Reading (dBuV)	Emission Level (dBuV/m)	Limits (dBuV/m)	Margin (dB)	Remark
1	2390.000	29.44	7.39	36.62	44.54	44.75	74.00	29.25	Peak
2	2400.000	29.44	7.43	36.62	45.49	45.74	74.00	28.26	Peak
3	2407.630	29.45	7.43	36.62	78.85	79.11	114.00	34.89	Peak

Remarks:

1. Emission Level= Antenna Factor + Cable Loss -Amp Factor + Reading.
2. The emission levels that are 20dB below the official limit are not reported.

Data: 15 File: E:\2010 report data\J20110311.EM6 (34)

Date: 2011-07-12

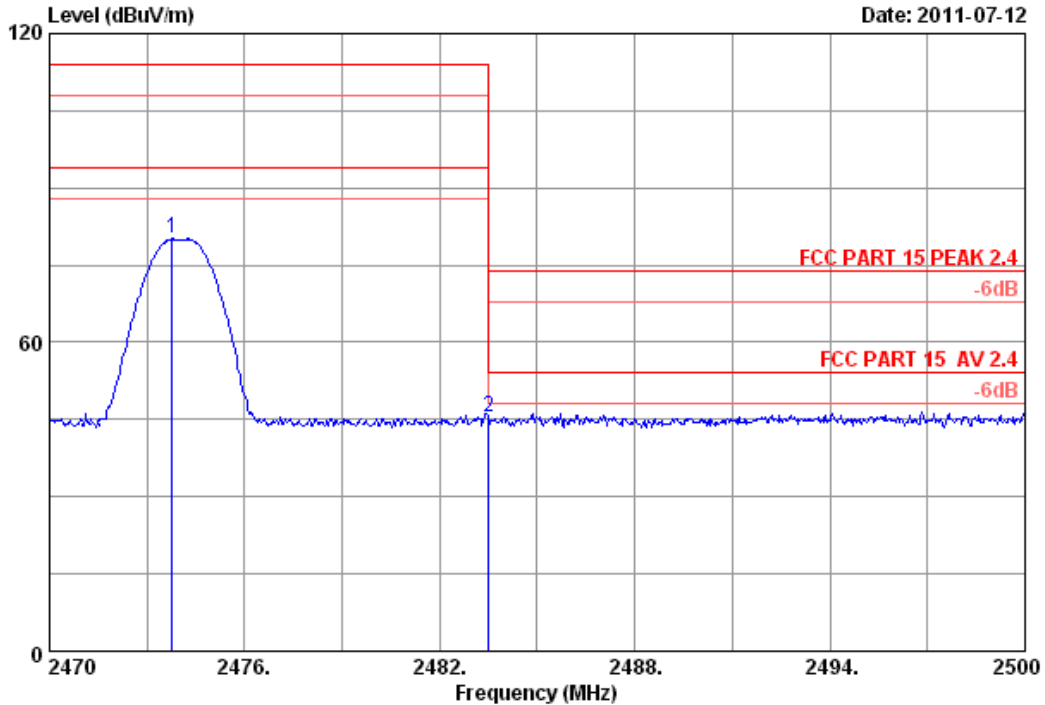

Site no. : 3# Chamber Data no. : 15
 Dis. / Ant. : 3m 3115(0911) Ant. pol. : VERTICAL
 Limit : FCC PART 15 PEAK 2.4
 Env. / Ins. : 23°C/54% Engineer : TaTa Chen
 EUT : Wireless Mouse
 Power : DC 1.5V
 Test mode : TX 2474
 M/N : M250R

	Ant. Freq. (MHz)	Factor (dB/m)	Cable loss (dB)	Amp. Factor (dB)	Reading (dBuV)	Emission Level (dBuV/m)	Limits (dBuV/m)	Margin (dB)	Remark
1	2473.750	29.49	7.58	36.60	79.61	80.08	114.00	33.92	Peak
2	2483.500	29.49	7.58	36.60	44.98	45.45	74.00	28.55	Peak

Remarks:

1. Emission Level= Antenna Factor + Cable Loss -amp Factor + Reading.
2. The emission levels that are 20dB below the official limit are not reported.

Data: 16 File: E:\2010 report data\J20110311.EM6 (34)

Date: 2011-07-12

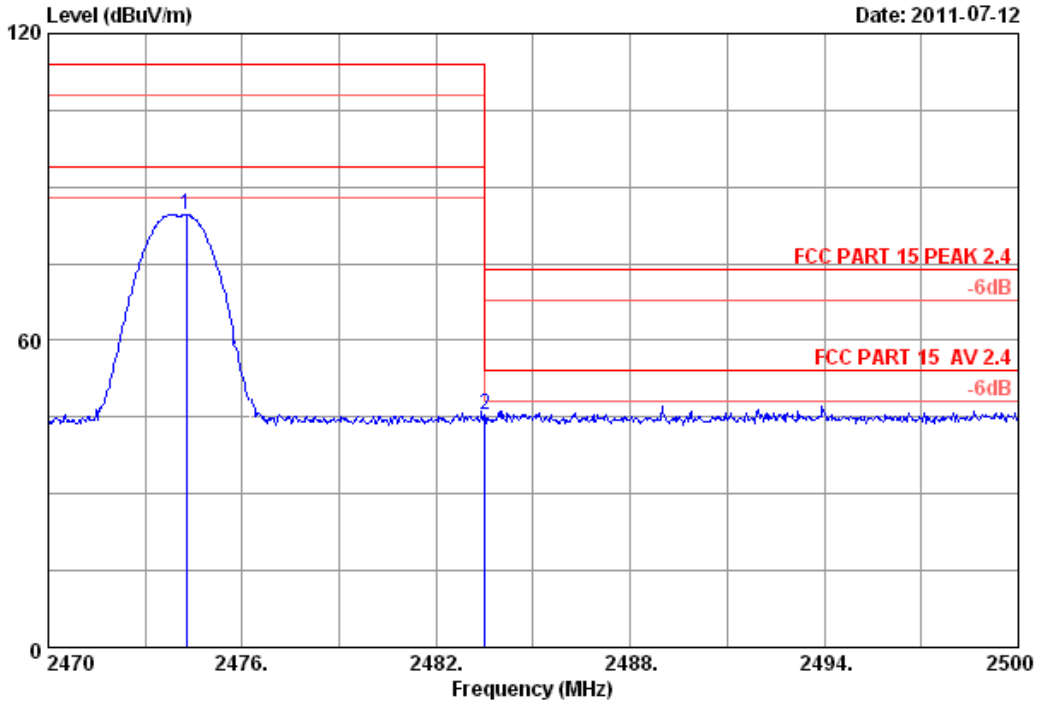

Site no. : 3# Chamber Data no. : 16
 Dis. / Ant. : 3m 3115(0911) Ant. pol. : HORIZONTAL
 Limit : FCC PART 15 PEAK 2.4
 Env. / Ins. : 23°C/54% Engineer : TaTa Chen
 EUT : Wireless Mouse
 Power : DC 1.5V
 Test mode : TX 2474
 M/N : M250R

	Ant. Freq. (MHz)	Ant. Factor (dB/m)	Cable loss (dB)	Amp. Factor (dB)	Emission Reading (dBuV)	Emission Level (dBuV/m)	Limits (dBuV/m)	Margin (dB)	Remark
1	2474.260	29.49	7.58	36.60	84.07	84.54	114.00	29.46	Peak
2	2483.500	29.49	7.58	36.60	44.93	45.40	74.00	28.60	Peak

Remarks:

1. Emission Level= Antenna Factor + Cable Loss -Amp Factor + Reading.
2. The emission levels that are 20dB below the official limit are not reported.

7. PHOTOGRAPH OF TEST

7.1.Photos of Radiated Emission Test (30-1000MHz)

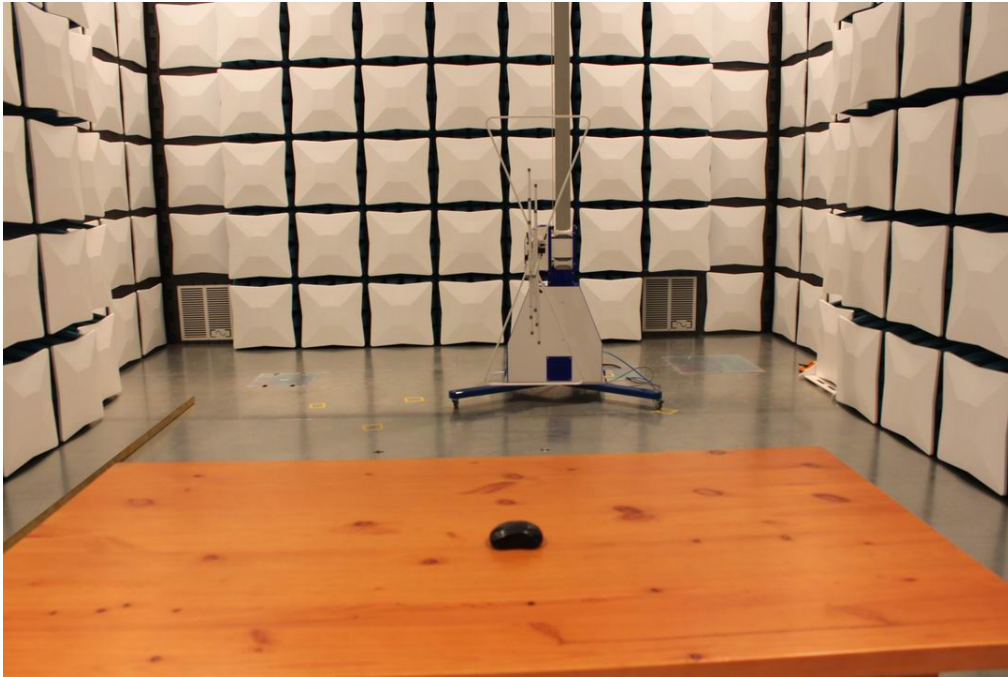

(Above 1000MHz)

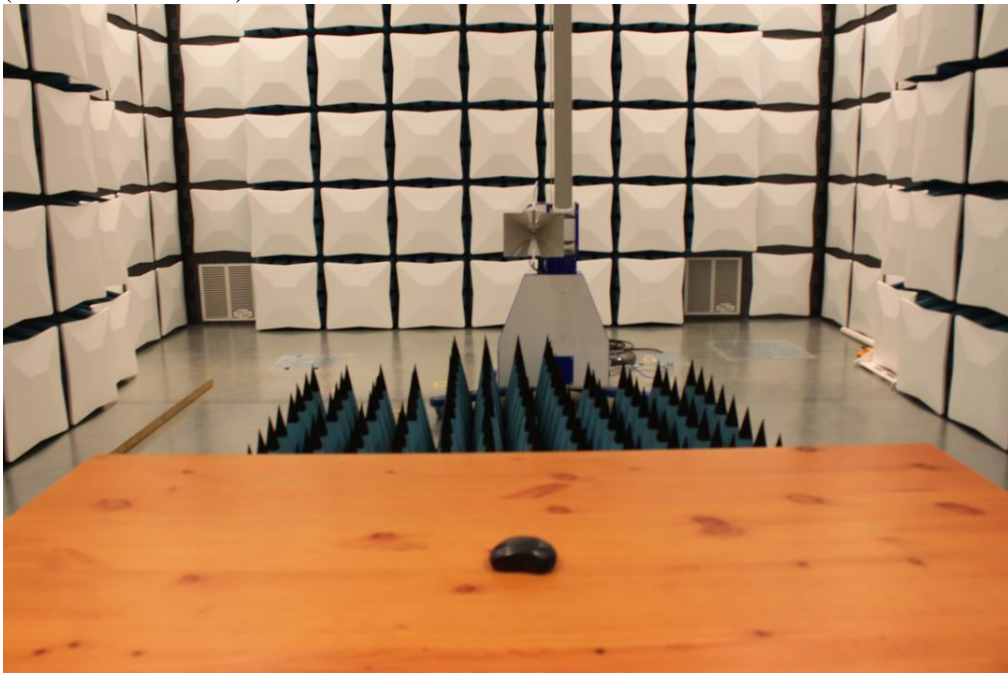

8. PHOTOGRAPH OF EUT

Figure 1
General Appearance of the EUT



Figure 2
General Appearance of the EUT



Figure 3
General Appearance of the EUT



Figure 4
General Appearance of the EUT



Figure 5
General Appearance of the EUT



Figure 6
Component Side of the PCB

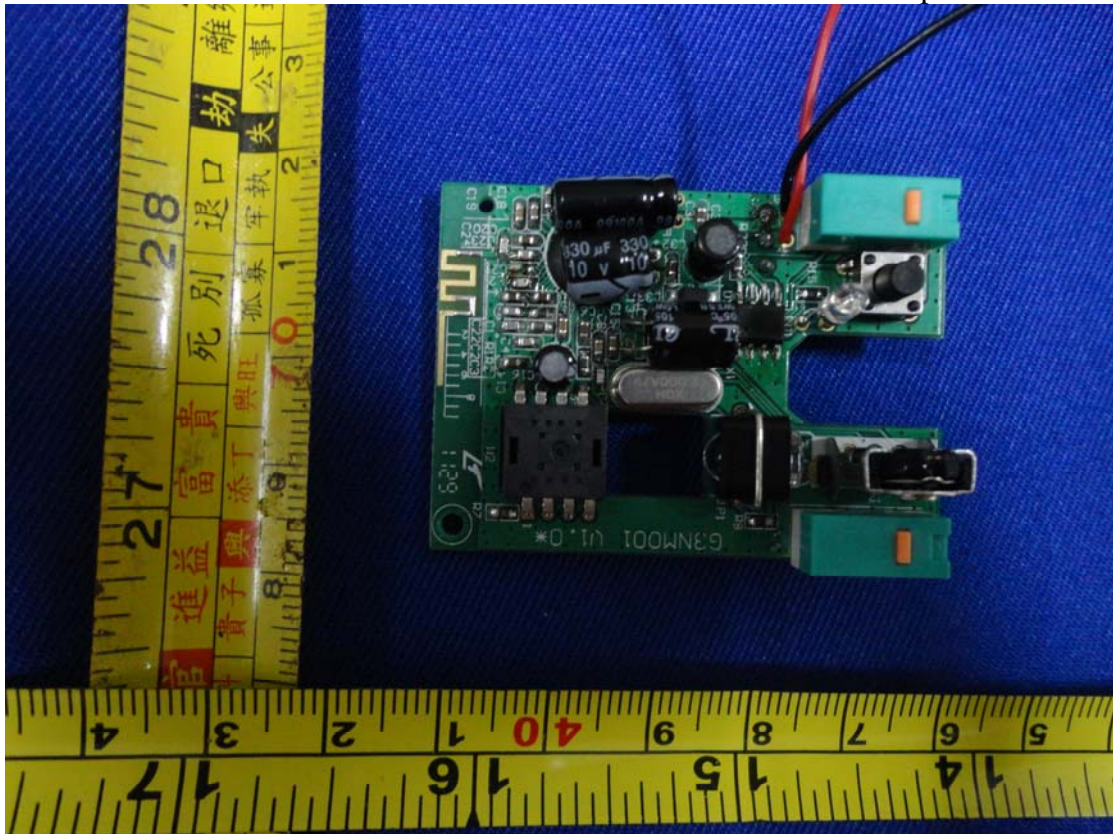

Figure 7
Component Side of the PCB

