

# FCC TEST REPORT

**REPORT NO. :** RF970626L16A

**MODEL NO. :** KB3 (refer to item 3.1 for more details)

**RECEIVED :** May 25, 2009

**TESTED :** Jun. 02 ~ Jun. 03, 2009

**ISSUED :** Jun. 05, 2009

**APPLICANT :** Acrox Technologies Co., Ltd

**ADDRESS :** 8F, No. 437, Rui Guang RD., Nei Hu Dist., Taipei  
114, Taiwan, R.O.C.

**ISSUED BY :** Bureau Veritas Consumer Products Services  
(H.K.) Ltd., Taoyuan Branch

**LAB ADDRESS :** No. 47, 14th Ling, Chia Pau Tsuen, Lin Kou  
Hsiang, Taipei Hsien 244, Taiwan, R.O.C.

**TEST LOCATION :** No. 19, Hwa Ya 2nd Rd, Wen Hwa Tsuen, Kwei  
Shan Hsiang, Taoyuan Hsien 333, Taiwan, R.O.C.

This test report consists of 23 pages in total. It may be duplicated completely for legal use with the approval of the applicant. It should not be reproduced except in full, without the written approval of our laboratory. The client should not use it to claim product endorsement by TAF or any government agency. The test results in the report only apply to the tested sample.



## Table of Contents

1.	CERTIFICATION .....	3
2.	SUMMARY OF TEST RESULTS .....	4
2.1	MEASUREMENT UNCERTAINTY .....	4
3.	GENERAL INFORMATION.....	5
3.1	GENERAL DESCRIPTION OF EUT .....	5
3.2	DESCRIPTION OF TEST MODES.....	6
3.2.1	CONFIGURATION OF SYSTEM UNDER TEST .....	6
3.2.2	TEST MODE APPLICABILITY AND TESTED CHANNEL DETAIL.....	7
3.3	GENERAL DESCRIPTION OF APPLIED STANDARDS .....	8
3.4	DESCRIPTION OF SUPPORT UNITS .....	8
4.	TEST TYPES AND RESULTS .....	9
4.1	RADIATED EMISSION MEASUREMENT .....	9
4.1.1	LIMITS OF RADIATED EMISSION MEASUREMENT.....	9
4.1.2	TEST INSTRUMENTS .....	10
4.1.3	TEST PROCEDURES .....	11
4.1.4	DEVIATION FROM TEST STANDARD .....	11
4.1.5	TEST SETUP .....	12
4.1.6	EUT OPERATING CONDITIONS .....	12
4.1.7	TEST RESULTS .....	13
4.2	BAND EDGES MEASUREMENT .....	18
4.2.1	LIMITS OF BAND EDGES MEASUREMENT .....	18
4.2.2	TEST INSTRUMENTS .....	18
4.2.3	TEST PROCEDURE .....	18
4.2.4	DEVIATION FROM TEST STANDARD .....	18
4.2.5	EUT OPERATING CONDITION .....	18
4.2.6	TEST RESULTS .....	18
5.	PHOTOGRAPHS OF THE TEST CONFIGURATION.....	21
6.	INFORMATION ON THE TESTING LABORATORIES .....	22
7.	APPENDIX A - MODIFICATIONS RECORDERS FOR ENGINEERING CHANGES TO THE EUT BY THE LAB.....	23



# 1. CERTIFICATION

**PRODUCT:** 2.4G Keyboard  
**MODEL NO.:** KB3 (refer to item 3.1 for more details)  
**BRAND:** ACROX  
**APPLICANT:** Acrox Technologies Co., Ltd  
**TESTED:** Jun. 02 ~ Jun. 03, 2009  
**TEST SAMPLE:** ENGINEERING SAMPLE  
**STANDARDS: FCC Part 15, Subpart C (Section 15.249)**  
**ANSI C63.4-2003**

The above equipment (model: KB3) have been tested by **Bureau Veritas Consumer Products Services (H.K.) Ltd., Taoyuan Branch**, and found compliance with the requirement of the above standards. The test record, data evaluation & Equipment Under Test (EUT) configurations represented herein are true and accurate accounts of the measurements of the sample’s EMC characteristics under the conditions specified in this report.

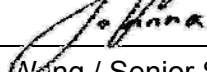
**PREPARED BY** :  , **DATE** : Jun. 05, 2009  
 Joanna Wang / Senior Specialist

**TECHNICAL ACCEPTANCE** :  , **DATE** : Jun. 05, 2009  
 Responsible for RF Long Chen / Senior Engineer

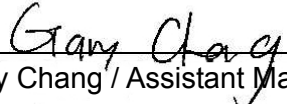
**APPROVED BY** :  , **DATE** : Jun. 05, 2009  
 Gary Chang / Assistant Manager

## 2. SUMMARY OF TEST RESULTS

The EUT has been tested according to the following specifications:

APPLIED STANDARD: FCC Part 15, Subpart C (Section 15.249)			
STANDARD PARAGRAPH	TEST TYPE	RESULT	REMARK
15.207	Conducted Emission Test	NA	Power supply is 3Vdc from batteries.
15.209 15.249 15.249 (d)	Radiated Emission Test Band Edge Measurement Limit: 50dB less than the peak value of fundamental frequency or meet radiated emission limit in section 15.209	PASS	Meet the requirement of limit. Minimum passing margin is -5.29dB at 4953.80MHz.

### 2.1 MEASUREMENT UNCERTAINTY

Where relevant, the following measurement uncertainty levels have been estimated for tests performed on the EUT as specified in CISPR 16-4-2:

MEASUREMENT	FREQUENCY	UNCERTAINTY
Radiated emissions	30MHz ~ 200MHz	2.93dB
	200MHz ~ 1000MHz	2.95dB
	1GHz ~ 18GHz	2.26dB
	18GHz ~ 40GHz	1.94dB

This uncertainty represents an expanded uncertainty expressed at approximately the 95% confidence level using a coverage factor of k=2.

### 3. GENERAL INFORMATION

#### 3.1 GENERAL DESCRIPTION OF EUT

<b>PRODUCT</b>	2.4G Keyboard
<b>MODEL NO.</b>	KB3 (refer to NOTE 2 for more details)
<b>FCC ID</b>	PRDCOWIFIKB03
<b>POWER SUPPLY</b>	3Vdc from batteries (1.5V AAA x 2)
<b>MODULATION TYPE</b>	GFSK
<b>DATA RATE</b>	1Mbps
<b>OPERATING FREQUENCY</b>	2404.9 ~ 2476.9MHz
<b>NUMBER OF CHANNEL</b>	73
<b>ANTENNA TYPE</b>	Printed antenna
<b>DATA CABLE</b>	NA
<b>I/O PORT</b>	NA
<b>ACCESSORY DEVICES</b>	NA

**NOTE:**

1. A set of the EUT include transmitter and receiver. This report covers transmitter only. The receiver is covered in another test report which report no.: FD970626L16A.
2. The following models are provided to this EUT.

MODEL	DESCRIPTION
KB3	For marketing different
KB1100W	

3. The above EUT information was declared by the manufacturer and for more detailed features description, please refer to the manufacturer's specifications or User's Manual.

### 3.2 DESCRIPTION OF TEST MODES

73 channels are provided to this EUT.

Channel	Freq. (MHz)	Channel	Freq. (MHz)	Channel	Freq. (MHz)
1	2404.9	26	2429.9	51	2454.9
2	2405.9	27	2430.9	52	2455.9
3	2406.9	28	2431.9	53	2456.9
4	2407.9	29	2432.9	54	2457.9
5	2408.9	30	2433.9	55	2458.9
6	2409.9	31	2434.9	56	2459.9
7	2410.9	32	2435.9	57	2460.9
8	2411.9	33	2436.9	58	2461.9
9	2412.9	34	2437.9	59	2462.9
10	2413.9	35	2438.9	60	2463.9
11	2414.9	36	2439.9	61	2464.9
12	2415.9	37	2440.9	62	2465.9
13	2416.9	38	2441.9	63	2466.9
14	2417.9	39	2442.9	64	2467.9
15	2418.9	40	2443.9	65	2468.9
16	2419.9	41	2444.9	66	2469.9
17	2420.9	42	2445.9	67	2470.9
18	2421.9	43	2446.9	68	2471.9
19	2422.9	44	2447.9	69	2472.9
20	2423.9	45	2448.9	70	2473.9
21	2424.9	46	2449.9	71	2474.9
22	2425.9	47	2450.9	72	2475.9
23	2426.9	48	2451.9	73	2476.9
24	2427.9	49	2452.9		
25	2428.9	50	2453.9		

#### 3.2.1 CONFIGURATION OF SYSTEM UNDER TEST

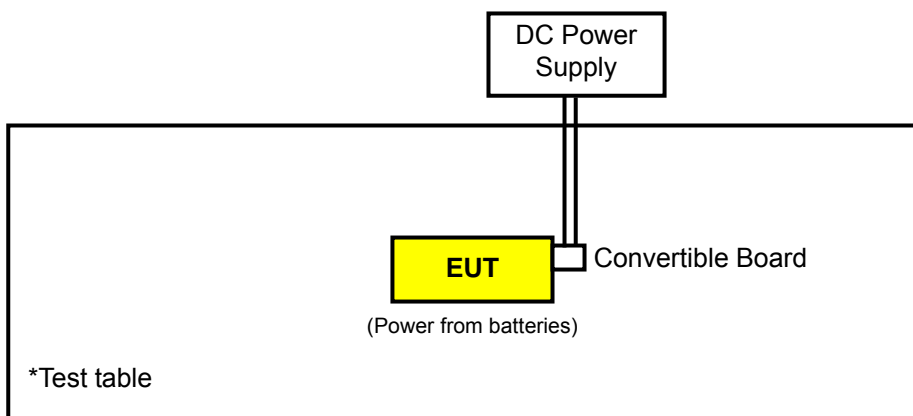

### 3.2.2 TEST MODE APPLICABILITY AND TESTED CHANNEL DETAIL

EUT CONFIGURE MODE	APPLICABLE TO				DESCRIPTION
	RE $\geq$ 1G	RE<1G	PLC	BM	
-	√	√	NOTE	√	-

Where **PLC**: Power Line Conducted Emission

**RE<1G**: Radiated Emission below 1GHz

**RE $\geq$ 1G**: Radiated Emission above 1GHz

**BM**: Bandedge Measurement

**NOTE**: No need to concern of Conducted Emission due to the EUT is powered by battery.

#### RADIATED EMISSION TEST (ABOVE 1 GHz):

- Pre-Scan has been conducted to determine the worst-case mode from all possible combinations between available modulations and antenna ports (if EUT with antenna diversity architecture).
- Following channel(s) was (were) selected for the final test as listed below.

AVAILABLE CHANNEL	TESTED CHANNEL	MODULATION TYPE
1 to 73	1, 43, 73	GFSK

#### RADIATED EMISSION TEST (BELOW 1 GHz):

- Pre-Scan has been conducted to determine the worst-case mode from all possible combinations between available modulations and antenna ports (if EUT with antenna diversity architecture).
- Following channel(s) was (were) selected for the final test as listed below.

AVAILABLE CHANNEL	TESTED CHANNEL	MODULATION TYPE
1 to 73	1	GFSK

#### BANDEDGE MEASUREMENT:

- Pre-Scan has been conducted to determine the worst-case mode from all possible combinations between available modulations and antenna ports (if EUT with antenna diversity architecture).
- Following channel(s) was (were) selected for the final test as listed below.

AVAILABLE CHANNEL	TESTED CHANNEL	MODULATION TYPE
1 to 73	1, 73	GFSK

### 3.3 GENERAL DESCRIPTION OF APPLIED STANDARDS

The EUT is a RF Product. According to the specifications of the manufacturer, it must comply with the requirements of the following standards:

#### **FCC Part 15, Subpart C (Section 15.249)**

#### **ANSI C63.4-2003**

All test items have been performed and recorded as per the above standards.

**NOTE:** The EUT is also considered as a kind of computer peripheral, because the connection to computer is necessary for typical use. It has been verified to comply with the requirements of FCC Part 15, Subpart B, Class B (DoC). The test report has been issued separately.

### 3.4 DESCRIPTION OF SUPPORT UNITS

The EUT has been tested as an independent unit together with other necessary accessories or support units. The following support units or accessories were used to form a representative test configuration during the tests.

NO.	PRODUCT	BRAND	MODEL NO.	SERIAL NO.	FCC ID
1	CONVERTIBLE BOARD	NA	NA	NA	NA
2	DC POWER SUPPLY	TOP WARD	6306A	713585	NA

NO.	SIGNAL CABLE DESCRIPTION OF THE ABOVE SUPPORT UNITS
1	NA
2	NA

**NOTE:**

1. All power cords of the above support units are non shielded (1.8m).
2. Convertible board was provided by the client and used to control EUT transmit at specific channel.
3. Item 2 was under test table during test.



## 4. TEST TYPES AND RESULTS

### 4.1 RADIATED EMISSION MEASUREMENT

#### 4.1.1 LIMITS OF RADIATED EMISSION MEASUREMENT

Emissions radiated outside of the specified bands, shall be according to the general radiated limits in 15.209, 15.249 as following:

15.209 Limit		
Frequencies (MHz)	Field strength (microvolts/meter)	Measurement distance (meters)
0.009 ~ 0.490	2400/F(kHz)	300
0.490 ~ 1.705	24000/F(kHz)	30
1.705 ~ 30.0	30	30
30 ~ 88	100	3
88 ~ 216	150	3
216 ~ 960	200	3
Above 960	500	3
15.249 Limit		
Fundamental Frequency	Field Strength of Fundamental (millivolts/meter)	Field Strength of Harmonics (microvolts/meter)
902 ~ 928 MHz	50	500
2400 ~ 2483.5 MHz	50	500
5725 ~ 5875 MHz	50	500
24 ~ 24.25 GHz	250	2500

**NOTE:**

1. The lower limit shall apply at the transition frequencies.
2. Emission level (dBuV/m) = 20 log Emission level (uV/m).
3. As shown in 15.35(b), for frequencies above 1000MHz, the field strength limits are based on average detector, however, the peak field strength of any emission shall not exceed the maximum permitted average limits, specified above by more than 20dB under any condition of modulation.



#### 4.1.2 TEST INSTRUMENTS

DESCRIPTION & MANUFACTURER	MODEL NO.	SERIAL NO.	DATE OF CALIBRATION	DUE DATE OF CALIBRATION
Test Receiver ROHDE & SCHWARZ	ESIB7	100212	May 25, 2009	May 24, 2010
Spectrum Analyzer ROHDE & SCHWARZ	FSP40	100269	Aug. 08, 2008	Aug. 07, 2009
BILOG Antenna SCHWARZBECK	VULB9168	9168-156	Apr. 30, 2009	Apr. 29, 2010
HORN Antenna SCHWARZBECK	BBHA 9120 D	9120D-563	Aug. 06, 2008	Aug. 05, 2009
HORN Antenna SCHWARZBECK	BBHA 9170	BBHA9170242	Jan. 06, 2009	Jan. 05, 2010
Loop Antenna	HFH2-Z2	100070	Jan. 14, 2008	Jan. 13, 2010
Preamplifier Agilent	8449B	3008A01911	Sep. 10, 2008	Sep. 09, 2009
Preamplifier Agilent	8447D	2944A10638	Dec. 26, 2008	Dec. 25, 2009
RF signal cable HUBER+SUHNNER	SUCOFLEX 104	218190/4 231241/4	May 13, 2009	May 12, 2010
RF signal cable Worken	8D-FB	Cable-HYCH9-01	Aug. 09, 2008	Aug. 08, 2009
Software	ADT_Radiated_ V7.6.15.9.2	NA	NA	NA
Antenna Tower EMCO	2070/2080	512.835.4684	NA	NA
Turn Table EMCO	2087-2.03	NA	NA	NA
Antenna Tower & Turn Table Controller EMCO	2090	NA	NA	NA

- NOTE:**
1. The calibration interval of the above test instruments is 12 months and the calibrations are traceable to NML/ROC and NIST/USA.
  2. The test was performed in HwaYa Chamber 9.
  3. The horn antenna and HP preamplifier (model: 8449B) are used only for the measurement of emission frequency above 1GHz if tested.
  4. The FCC Site Registration No. is 460141.
  5. The IC Site Registration No. is IC 7450F-4.

#### 4.1.3 TEST PROCEDURES

- a. The EUT was placed on the top of a rotating table 0.8 meters above the ground at a 3 meter semi-anechoic chamber. The table was rotated 360 degrees to determine the position of the highest radiation.
- b. The EUT was set 3 meters away from the interference-receiving antenna, which was mounted on the top of a variable-height antenna tower.
- c. The antenna is a broadband antenna, and its height is varied from one meter to four meters above the ground to determine the maximum value of the field strength. Both horizontal and vertical polarizations of the antenna are set to make the measurement.
- d. For each suspected emission, the EUT was arranged to its worst case and then the antenna was tuned to heights from 1 meter to 4 meters and the rotatable table was turned from 0 degrees to 360 degrees to find the maximum reading.
- e. The test-receiver system was set to Peak Detect Function and Specified Bandwidth with Maximum Hold Mode.
- f. If the emission level of the EUT in peak mode was lower than the limit specified, then testing could be stopped and the peak values of the EUT would be reported. Otherwise the emissions would be re-tested one by one using peak, quasi-peak or average method as specified and then reported in a data sheet.

**NOTE:**

1. The resolution bandwidth and video bandwidth of test receiver/spectrum analyzer is 120kHz for Quasi-peak detection at frequency below 1GHz.
2. The resolution bandwidth of test receiver/spectrum analyzer is 1 MHz and video bandwidth is 3MHz for Peak detection at frequency above 1GHz.
3. All modes of operation were investigated and the worst-case emissions are reported.

#### 4.1.4 DEVIATION FROM TEST STANDARD

No deviation.

#### 4.1.5 TEST SETUP

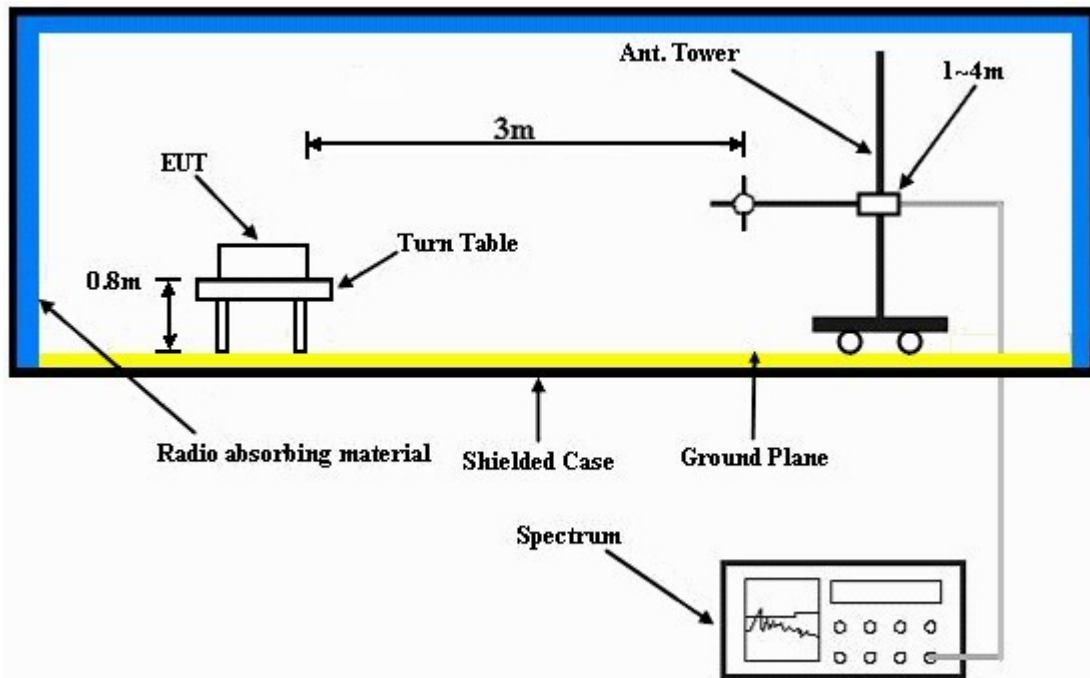

For the actual test configuration, please refer to the attached file (Test Setup Photo).

#### 4.1.6 EUT OPERATING CONDITIONS

Set the EUT under transmission condition continuously at specific channel frequency.



## 4.1.7 TEST RESULTS

### ABOVE 1GHz DATA

EUT TEST CONDITION		MEASUREMENT DETAIL	
CHANNEL	Channel 1	FREQUENCY RANGE	1 ~ 25GHz
MODULATION TYPE	GFSK	DETECTOR FUNCTION	Peak (PK) Average (AV)
ENVIRONMENTAL CONDITIONS	24.0deg. C, 64.0%RH 1004hPa	TESTED BY	Antony Lee

ANTENNA POLARITY & TEST DISTANCE: HORIZONTAL AT 3 M								
NO.	FREQ. (MHz)	EMISSION LEVEL (dBuV/m)	LIMIT (dBuV/m)	MARGIN (dB)	ANTENNA HEIGHT (m)	TABLE ANGLE (Degree)	RAW VALUE (dBuV)	CORRECTION FACTOR (dB/m)
1	2390.00	41.68 PK	74.00	-32.32	1.31 H	113	8.60	33.08
2	2390.00	29.07 AV	54.00	-24.93	1.31 H	113	-4.01	33.08
3	2400.00	36.05 PK	74.00	-37.95	1.31 H	113	2.92	33.13
4	2400.00	18.62 AV	54.00	-35.38	1.31 H	113	-14.51	33.13
5	*2404.90	93.75 PK	114.00	-20.25	1.31 H	113	60.60	33.15
6	*2404.90	76.32 AV	94.00	-17.68	1.31 H	113	43.17	33.15
7	4809.80	63.60 PK	74.00	-10.40	1.20 H	114	24.45	39.15
8	4809.80	46.17 AV	54.00	-7.83	1.20 H	114	7.02	39.15
ANTENNA POLARITY & TEST DISTANCE: VERTICAL AT 3 M								
NO.	FREQ. (MHz)	EMISSION LEVEL (dBuV/m)	LIMIT (dBuV/m)	MARGIN (dB)	ANTENNA HEIGHT (m)	TABLE ANGLE (Degree)	RAW VALUE (dBuV)	CORRECTION FACTOR (dB/m)
1	2390.00	40.02 PK	74.00	-33.98	1.14 V	155	6.94	33.08
2	2390.00	29.29 AV	54.00	-24.71	1.14 V	155	-3.79	33.08
3	2400.00	36.83 PK	74.00	-37.17	1.15 V	156	3.70	33.13
4	2400.00	19.40 AV	54.00	-34.60	1.15 V	156	-13.73	33.13
5	*2404.90	88.84 PK	114.00	-25.16	1.15 V	156	55.69	33.15
6	*2404.90	71.41 AV	94.00	-22.59	1.15 V	156	38.26	33.15
7	4809.80	60.67 PK	74.00	-13.33	1.00 V	102	21.52	39.15
8	4809.80	43.24 AV	54.00	-10.76	1.00 V	102	4.09	39.15

- REMARKS:**
1. Emission level (dBuV/m) = Raw Value (dBuV) + Correction Factor (dB/m).
  2. Correction Factor (dB/m) = Antenna Factor (dB/m) + Cable Factor (dB).
  3. The other emission levels were very low against the limit.
  4. Margin value = Emission level – Limit value.
  5. “ \* “ : Fundamental frequency
  6. The average value of fundamental frequency is: Average = Peak value + 20log(Duty cycle) Where the duty factor is calculated from following formula:  
 $20 \log (\text{Duty cycle}) = 20 \log (13.44 \text{ ms} / 100 \text{ ms}) = -17.43 \text{ dB}$   
 Please see page 16 for plotted duty.



A D T

EUT TEST CONDITION		MEASUREMENT DETAIL	
CHANNEL	Channel 43	FREQUENCY RANGE	1 ~ 25GHz
MODULATION TYPE	GFSK	DETECTOR FUNCTION	Peak (PK) Average (AV)
ENVIRONMENTAL CONDITIONS	24.0deg. C, 64.0%RH 1004hPa	TESTED BY	Antony Lee

ANTENNA POLARITY & TEST DISTANCE: HORIZONTAL AT 3 M								
NO.	FREQ. (MHz)	EMISSION LEVEL (dBuV/m)	LIMIT (dBuV/m)	MARGIN (dB)	ANTENNA HEIGHT (m)	TABLE ANGLE (Degree)	RAW VALUE (dBuV)	CORRECTION FACTOR (dB/m)
1	*2446.90	92.80 PK	114.00	-21.20	1.28 H	112	59.48	33.32
2	*2446.90	75.37 AV	94.00	-18.63	1.28 H	112	42.05	33.32
3	4893.80	65.89 PK	74.00	-8.11	1.05 H	119	26.75	39.14
4	4893.80	48.46 AV	54.00	-5.54	1.05 H	119	9.32	39.14
ANTENNA POLARITY & TEST DISTANCE: VERTICAL AT 3 M								
NO.	FREQ. (MHz)	EMISSION LEVEL (dBuV/m)	LIMIT (dBuV/m)	MARGIN (dB)	ANTENNA HEIGHT (m)	TABLE ANGLE (Degree)	RAW VALUE (dBuV)	CORRECTION FACTOR (dB/m)
1	*2446.90	89.12 PK	114.00	-24.88	1.15 V	142	55.80	33.32
2	*2446.90	71.69 AV	94.00	-22.31	1.15 V	142	38.37	33.32
3	4893.80	64.48 PK	74.00	-9.52	1.00 V	102	25.34	39.14
4	4893.80	47.05 AV	54.00	-6.95	1.00 V	102	7.91	39.14

- REMARKS:**
1. Emission level (dBuV/m) = Raw Value (dBuV) + Correction Factor (dB/m).
  2. Correction Factor (dB/m) = Antenna Factor (dB/m) + Cable Factor (dB).
  3. The other emission levels were very low against the limit.
  4. Margin value = Emission level – Limit value.
  5. “ \* ” : Fundamental frequency
  6. The average value of fundamental frequency is: Average = Peak value + 20log(Duty cycle) Where the duty factor is calculated from following formula:  
 $20 \log (\text{Duty cycle}) = 20 \log (13.44 \text{ ms} / 100 \text{ ms}) = -17.43 \text{ dB}$   
 Please see page 16 for plotted duty.

EUT TEST CONDITION		MEASUREMENT DETAIL	
CHANNEL	Channel 73	FREQUENCY RANGE	1 ~ 25GHz
MODULATION TYPE	GFSK	DETECTOR FUNCTION	Peak (PK) Average (AV)
ENVIRONMENTAL CONDITIONS	24.0deg. C, 64.0%RH 1004hPa	TESTED BY	Antony Lee

ANTENNA POLARITY & TEST DISTANCE: HORIZONTAL AT 3 M								
NO.	FREQ. (MHz)	EMISSION LEVEL (dBuV/m)	LIMIT (dBuV/m)	MARGIN (dB)	ANTENNA HEIGHT (m)	TABLE ANGLE (Degree)	RAW VALUE (dBuV)	CORRECTION FACTOR (dB/m)
1	*2476.90	92.96 PK	114.00	-21.04	1.22 H	122	59.52	33.44
2	*2476.90	75.53 AV	94.00	-18.47	1.22 H	122	42.09	33.44
3	2483.50	35.03 PK	74.00	-38.97	1.22 H	122	1.57	33.46
4	2483.50	17.60 AV	54.00	-36.40	1.22 H	122	-15.86	33.46
5	4953.80	66.14 PK	74.00	-7.86	1.46 H	117	26.53	39.61
6	4953.80	48.71 AV	54.00	-5.29	1.46 H	117	9.10	39.61

ANTENNA POLARITY & TEST DISTANCE: VERTICAL AT 3 M								
NO.	FREQ. (MHz)	EMISSION LEVEL (dBuV/m)	LIMIT (dBuV/m)	MARGIN (dB)	ANTENNA HEIGHT (m)	TABLE ANGLE (Degree)	RAW VALUE (dBuV)	CORRECTION FACTOR (dB/m)
1	*2476.90	89.32 PK	114.00	-24.68	1.12 V	124	55.88	33.44
2	*2476.90	71.89 AV	94.00	-22.11	1.12 V	124	38.45	33.44
3	2483.50	34.58 PK	74.00	-39.42	1.12 V	124	1.12	33.46
4	2483.50	17.15 AV	54.00	-36.85	1.12 V	124	-16.31	33.46
5	4953.80	65.18 PK	74.00	-8.82	1.00 V	94	25.57	39.61
6	4953.80	47.75 AV	54.00	-6.25	1.00 V	94	8.14	39.61

- REMARKS:**
1. Emission level (dBuV/m) = Raw Value (dBuV) + Correction Factor (dB/m).
  2. Correction Factor (dB/m) = Antenna Factor (dB/m) + Cable Factor (dB).
  3. The other emission levels were very low against the limit.
  4. Margin value = Emission level – Limit value.
  5. “ \* “ : Fundamental frequency
  6. The average value of fundamental frequency is: Average = Peak value + 20log(Duty cycle) Where the duty factor is calculated from following formula:  
 $20 \log (\text{Duty cycle}) = 20 \log (13.44 \text{ ms} / 100 \text{ ms}) = -17.43 \text{ dB}$   
 Please see page 16 for plotted duty.



A D T

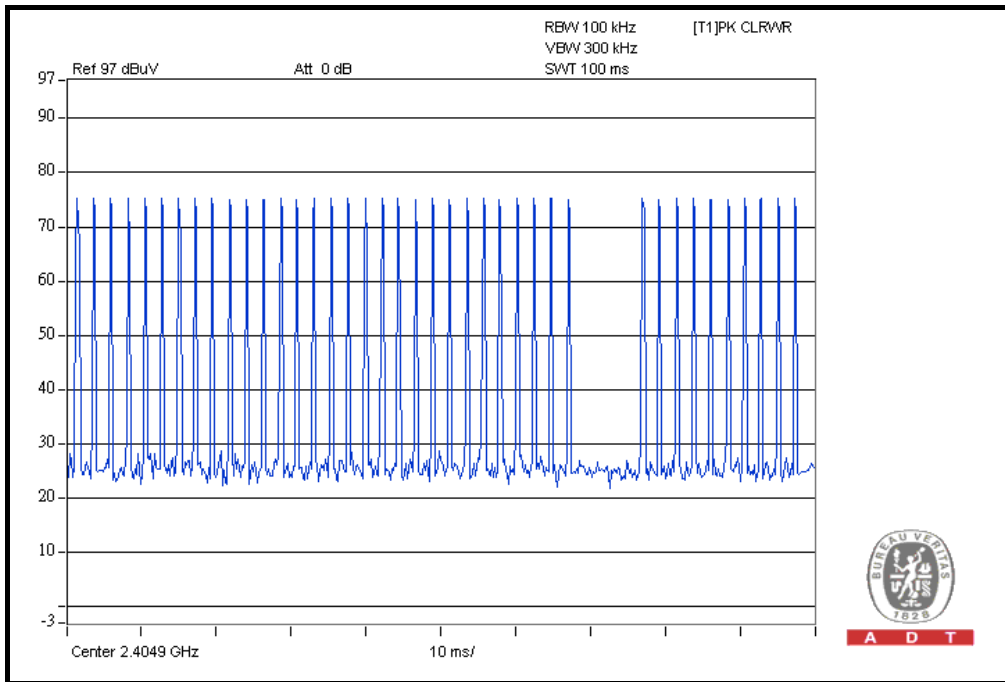

A D T

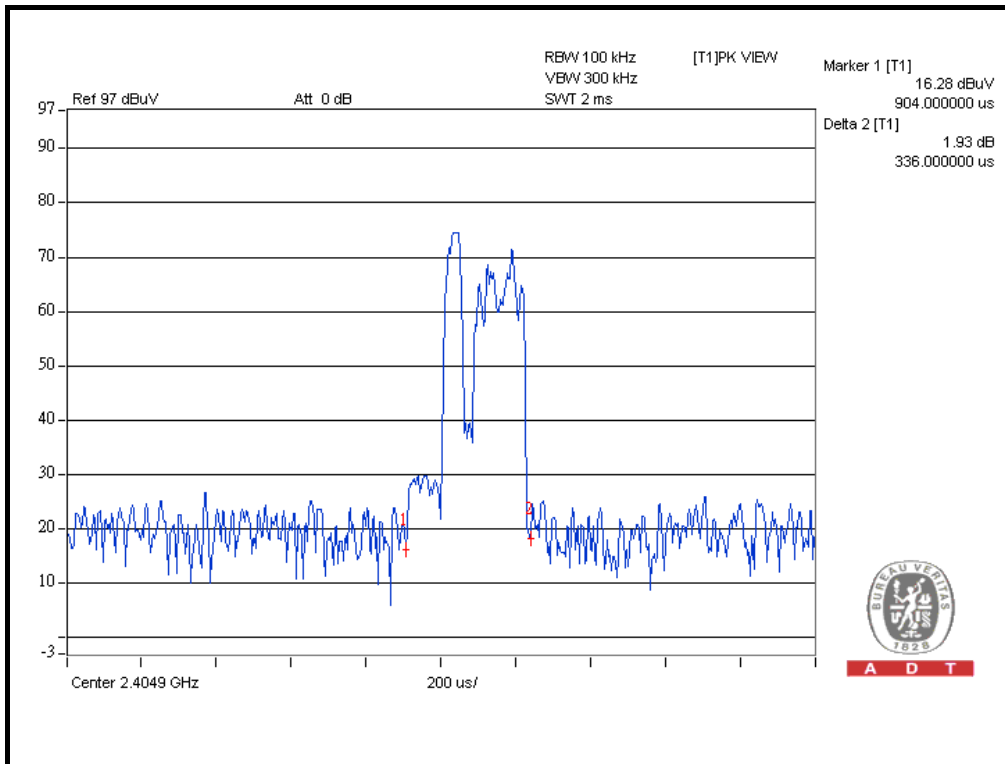

A D T

$$20 \log (\text{Duty cycle}) = 20 \log (0.336 \text{ ms} \times 40 / 100 \text{ ms}) = -17.43 \text{ dB}$$



**BELOW 1GHz WORST-CASE DATA**

EUT TEST CONDITION		MEASUREMENT DETAIL	
CHANNEL	Channel 1	FREQUENCY RANGE	Below 1000MHz
MODULATION TYPE	GFSK	DETECTOR FUNCTION	Quasi-Peak
ENVIRONMENTAL CONDITIONS	24.0deg. C, 64.0%RH 1000hPa	TESTED BY	Antony Lee

ANTENNA POLARITY & TEST DISTANCE: HORIZONTAL AT 3 M								
NO.	FREQ. (MHz)	EMISSION LEVEL (dBuV/m)	LIMIT (dBuV/m)	MARGIN (dB)	ANTENNA HEIGHT (m)	TABLE ANGLE (Degree)	RAW VALUE (dBuV)	CORRECTION FACTOR (dB/m)
1	119.34	31.24 QP	43.50	-12.26	1.50 H	97	19.57	11.67
2	167.94	31.99 QP	43.50	-11.51	1.50 H	268	18.88	13.11
3	239.88	33.95 QP	46.00	-12.05	1.25 H	250	21.57	12.38
4	383.76	40.37 QP	46.00	-5.63	1.00 H	301	24.70	15.67
5	407.09	35.28 QP	46.00	-10.72	1.00 H	307	18.98	16.30
6	877.61	29.73 QP	46.00	-16.27	1.00 H	64	3.83	25.90
ANTENNA POLARITY & TEST DISTANCE: VERTICAL AT 3 M								
NO.	FREQ. (MHz)	EMISSION LEVEL (dBuV/m)	LIMIT (dBuV/m)	MARGIN (dB)	ANTENNA HEIGHT (m)	TABLE ANGLE (Degree)	RAW VALUE (dBuV)	CORRECTION FACTOR (dB/m)
1	35.73	32.66 QP	40.00	-7.34	1.00 V	97	20.48	12.17
2	70.73	34.37 QP	40.00	-5.63	1.00 V	298	23.08	11.30
3	360.43	33.23 QP	46.00	-12.77	1.00 V	343	18.13	15.10
4	383.76	33.29 QP	46.00	-12.71	2.00 V	331	17.62	15.67
5	395.43	32.27 QP	46.00	-13.73	1.00 V	334	16.32	15.95
6	704.57	27.43 QP	46.00	-18.57	1.25 V	304	4.58	22.84

- REMARKS:**
1. Emission level (dBuV/m) = Raw Value (dBuV) + Correction Factor (dB/m).
  2. Correction Factor (dB/m) = Antenna Factor (dB/m) + Cable Factor (dB).
  3. The other emission levels were very low against the limit.
  4. Margin value = Emission level – Limit value.

## 4.2 BAND EDGES MEASUREMENT

### 4.2.1 LIMITS OF BAND EDGES MEASUREMENT

Below  $-50\text{dB}$  of the highest emission level of operating band (in 100kHz Resolution Bandwidth).

### 4.2.2 TEST INSTRUMENTS

DESCRIPTION & MANUFACTURER	MODEL NO.	SERIAL NO.	DATE OF CALIBRATION	DUE DATE OF CALIBRATION
R&S SPECTRUM ANALYZER	FSP40	100040	Jul. 04, 2008	Jul. 03, 2009

**NOTE:** The calibration interval of the above test instruments is 12 months and the calibrations are traceable to NML/ROC and NIST/USA.

### 4.2.3 TEST PROCEDURE

The transmitter output was connected to the spectrum analyzer via a low loss cable. Set both RBW and VBW of spectrum analyzer to 100 kHz and 300 kHz with suitable frequency span including 100 MHz bandwidth from band edge. The band edges was measured and recorded.

The spectrum plots are attached on the following pages.

### 4.2.4 DEVIATION FROM TEST STANDARD

No deviation.

### 4.2.5 EUT OPERATING CONDITION

The software provided by client to enable the EUT under transmission condition continuously at lowest and highest channel frequencies individually.

### 4.2.6 TEST RESULTS

The spectrum plots are attached on the following 4 images. D1 line indicates the highest level, and D2 line indicates the 50dB offset below D1. It shows compliance with the requirement in part 15.249 (d).



A D T

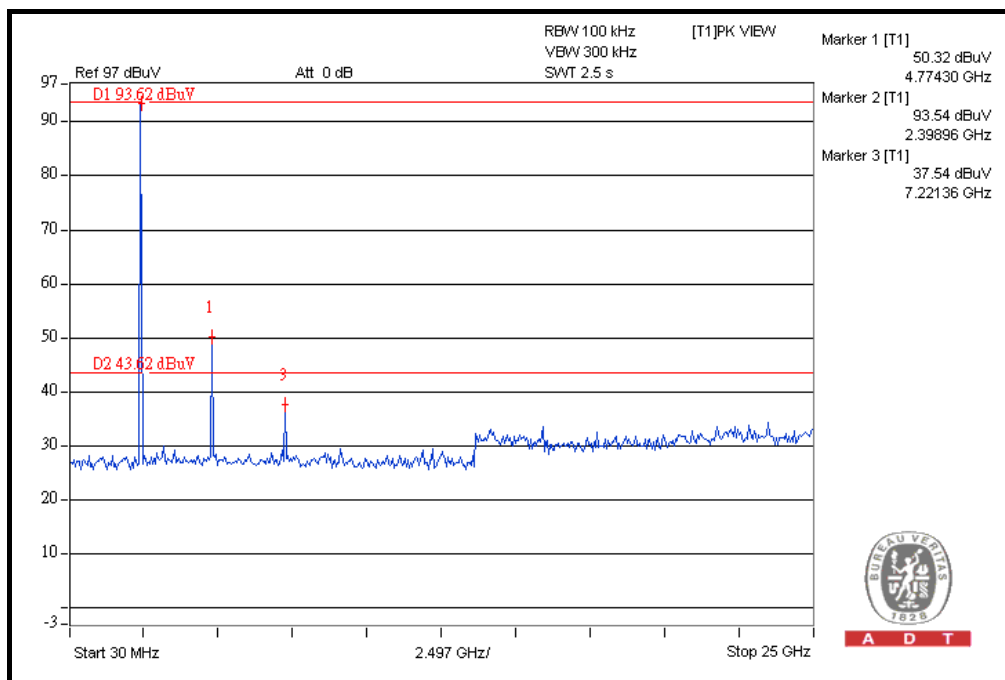
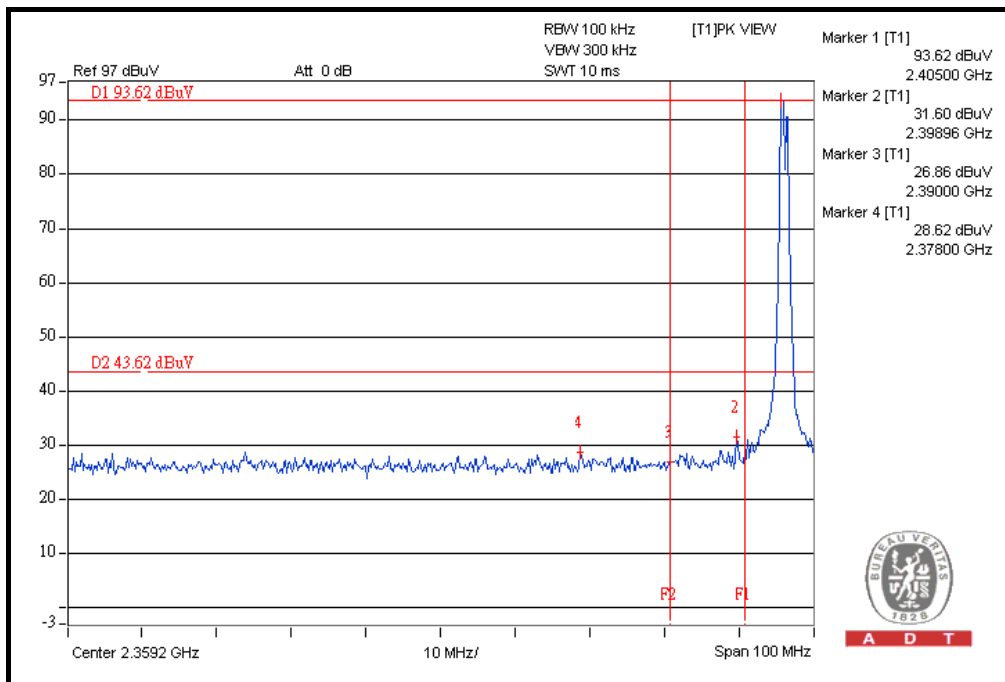



A D T

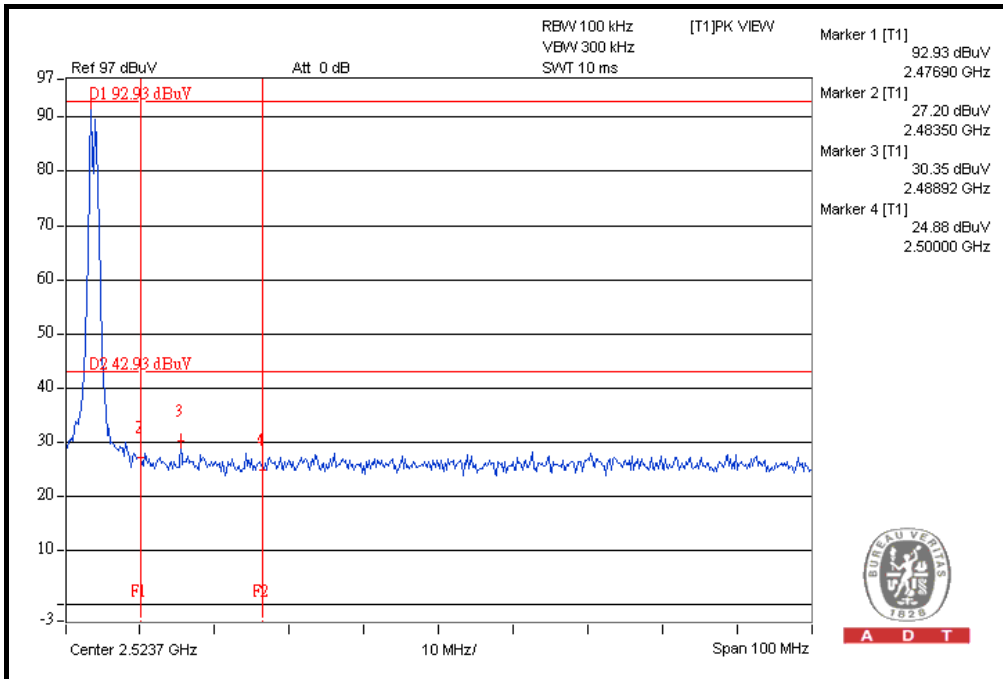

A D T

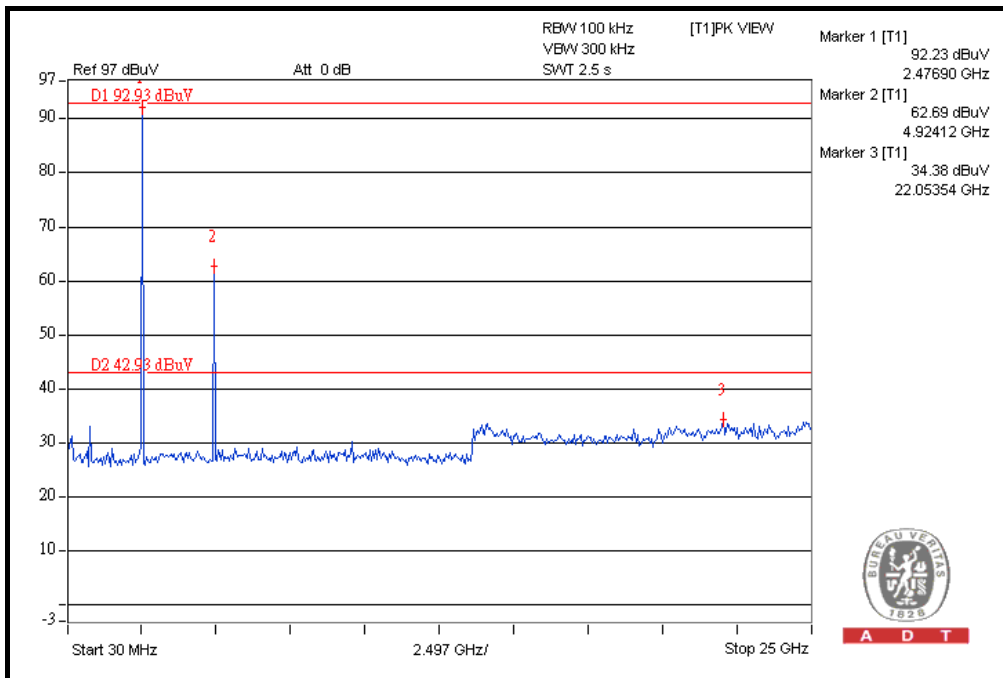

A D T



## 5. PHOTOGRAPHS OF THE TEST CONFIGURATION

Please refer to the attached file (Test Setup Photo).



## 6. INFORMATION ON THE TESTING LABORATORIES

We, Bureau Veritas Consumer Products Services (H.K.) Ltd., Taoyuan Branch, were founded in 1988 to provide our best service in EMC, Radio, Telecom and Safety consultation. Our laboratories are accredited and approved by the following approval agencies according to ISO/IEC 17025.

<b>USA</b>	FCC, NVLAP
<b>Germany</b>	TUV Rheinland
<b>Japan</b>	VCCI
<b>Norway</b>	NEMKO
<b>Canada</b>	INDUSTRY CANADA, CSA
<b>R.O.C.</b>	TAF, BSMI, NCC
<b>Netherlands</b>	Telefication
<b>Singapore</b>	GOST-ASIA(MOU)
<b>Russia</b>	CERTIS(MOU)

Copies of accreditation certificates of our laboratories obtained from approval agencies can be downloaded from our web site: [www.adt.com.tw/index.5/phtml](http://www.adt.com.tw/index.5/phtml). If you have any comments, please feel free to contact us at the following:

**Linko EMC/RF Lab**  
Tel: 886-2-26052180  
Fax: 886-2-26051924

**Hsin Chu EMC/RF Lab**  
Tel: 886-3-5935343  
Fax: 886-3-5935342

**Hwa Ya EMC/RF/Safety Telecom Lab**  
Tel: 886-3-3183232  
Fax: 886-3-3185050

**Web Site:** [www.adt.com.tw](http://www.adt.com.tw)

The address and road map of all our labs can be found in our web site also

## **7. APPENDIX A - MODIFICATIONS RECORDERS FOR ENGINEERING CHANGES TO THE EUT BY THE LAB**

No any modifications are made to the EUT by the lab during the test.

**--- END ---**