

# ⚠ WARNING



**Electrical Shock Hazard**  
**Disconnect power before servicing.**  
**Replace all parts and panels before operating.**  
**Failure to do so can result in death or electrical shock.**

## Models:

665.62612200  
 665.62614200  
 665.62619200

## PRECAUTIONS TO BE OBSERVED BEFORE AND DURING SERVICING TO AVOID POSSIBLE EXPOSURE TO EXCESSIVE MICROWAVE ENERGY

- a. Do not operate or allow the oven to be operated with the door open.
- b. Make the following safety checks on all ovens to be serviced before activating the magnetron or other microwave source, and make repairs as necessary:
  1. Interlock Operation
  2. Proper Door Closing
  3. Seal and Sealing Surfaces (Arcing, Wear & Other Damage)
  4. Damage to or Loosening of Hinges & Latches
  5. Evidence of Dropping or Abuse
- c. Before turning on microwave power for any service test or inspection within the microwave generating compartments,
  - d. check the magnetron, waveguide or transmission line and cavity for proper alignment, integrity and connections.
  - e. Any defective or misadjusted components in the interlock, monitor, door seal, and microwave generation, and transmission systems shall be repaired, replaced, or adjusted by procedures described in service manual before the oven is released to the owner.
  - e. A microwave leakage check to verify compliance with the Federal performance standard should be performed on each oven prior to release to the owner.
  - f. Do not attempt to operate the oven if the window area of the door is broken.

## POWER OUTPUT MEASUREMENT

The power output of the magnetron can be measured by the following tap water temperature rise test:

- ✓ Be sure oven cavity is clean and cool (not used recently).
  - ✓ Low voltage will lower the magnetron output.
1. Fill a glass beaker with 1000 ml (32 oz.) of tap water. Stir the water with a thermometer (digital recommended) and record the temperature. This starting temperature should be between 10°C (50°F) to 24°C (75°F).

2. Place the beaker in the center of the oven. Operate on HIGH power level for 60 seconds.
3. When done, stir the thermometer through the water and record the temperature.
4. Subtract the cold water temperature from the warm water temperature to get the temperature rise. Normal range is as shown in the following table:

Voltage (VAC under load)	Temperature Rise	
	°C	°F
120V	12 - 13	21 - 24
108V	10 - 11	18 - 19

## FAILURE CODES/INDICATIONS

Display	Likely Failure Condition	Recommended Repair Procedure
Flashing colon ":"	Power failure	After a power failure, the colon ":" will be flashing. Press any key to end this indication. The colon will then be steady when in stand-by.
-F2-	Membrane switch failure	Replace membrane switch. If problem persists, replace control board.
-F5-	Microwave relay failure	Check wiring to relay 4903 for short circuits. If wiring is OK, replace control board.

**SCHEMATIC DIAGRAM**

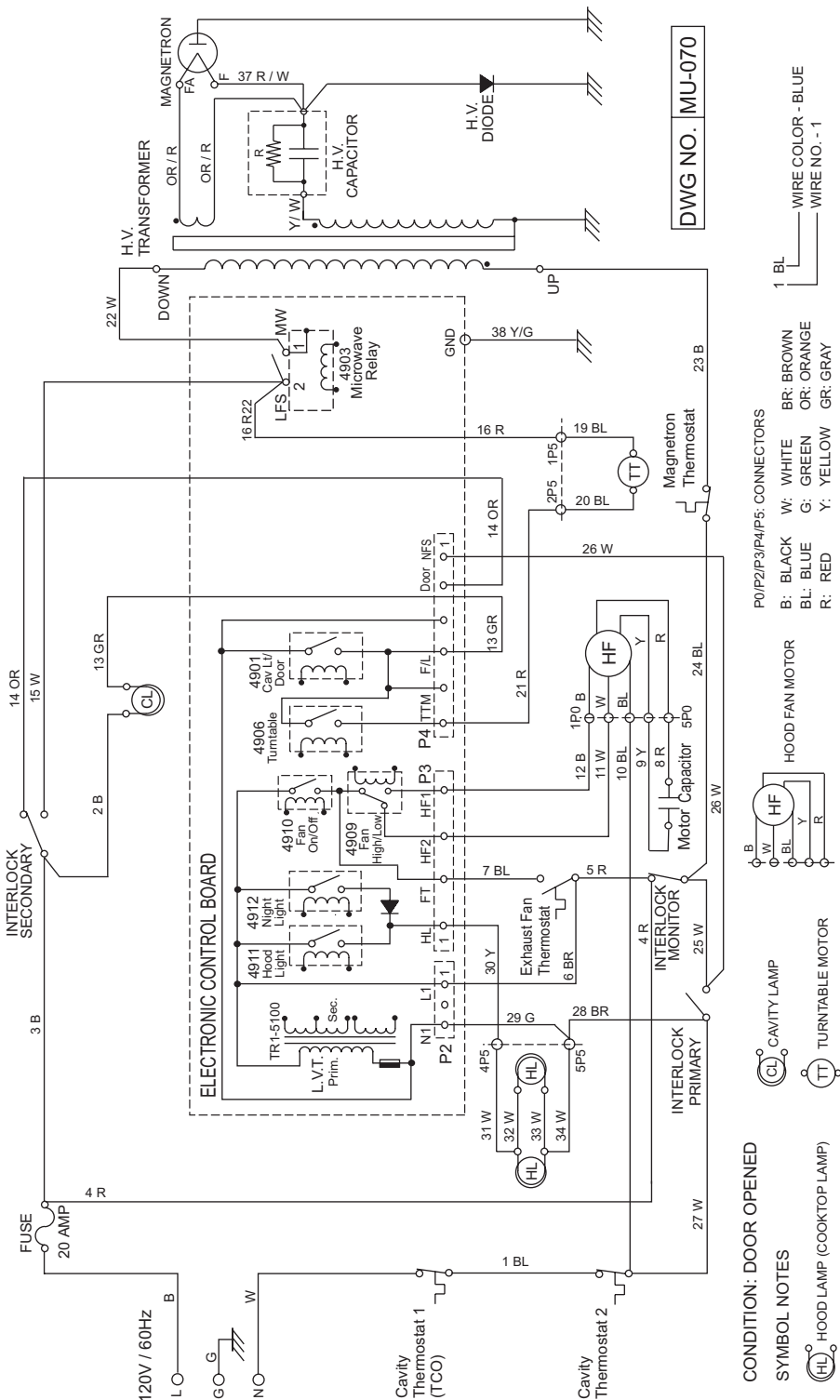

DWG NO. IMU-070

PICTORIAL DIAGRAM

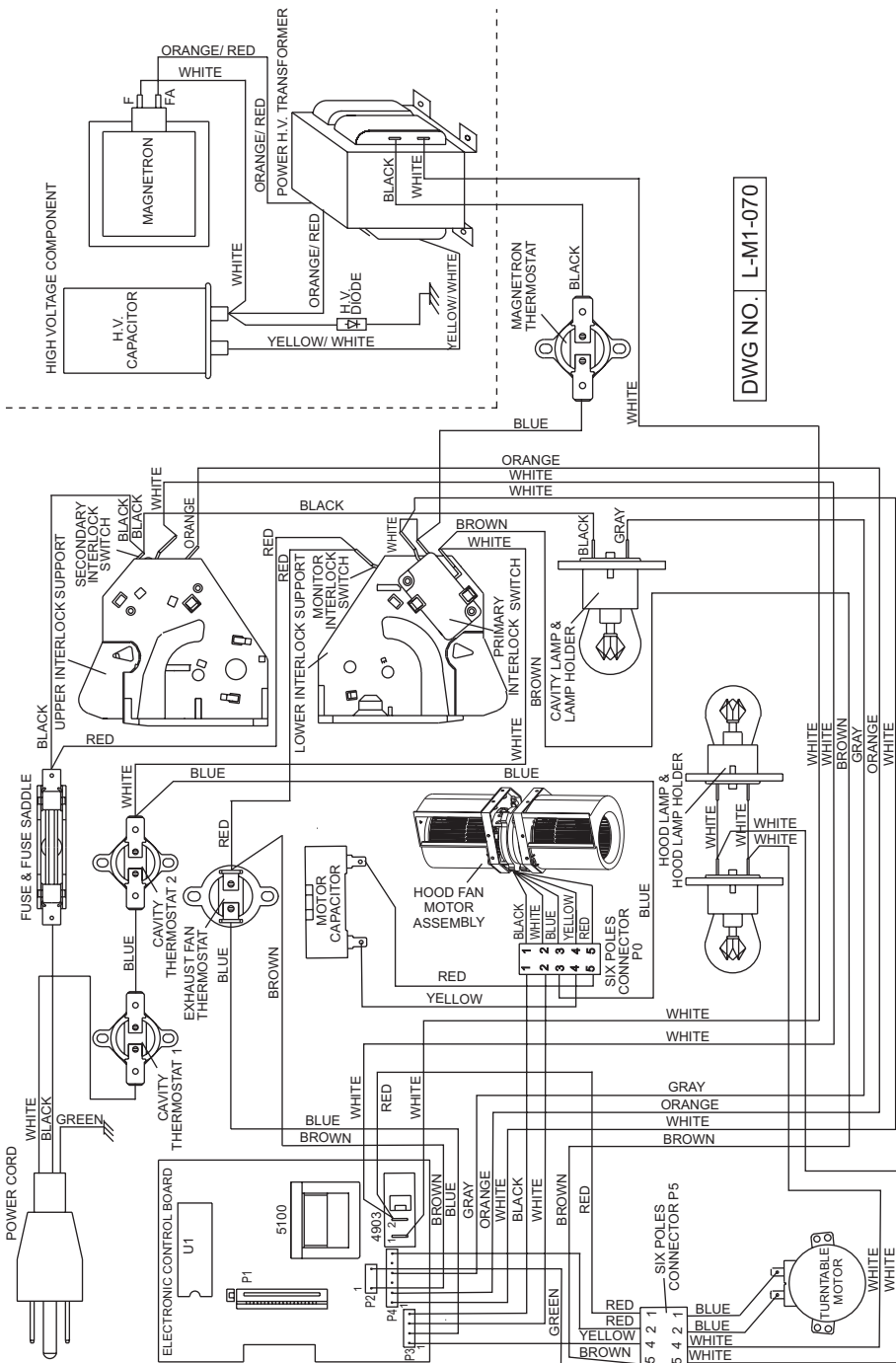

DWG NO. L-M1-070

PICTORIAL DIAGRAM

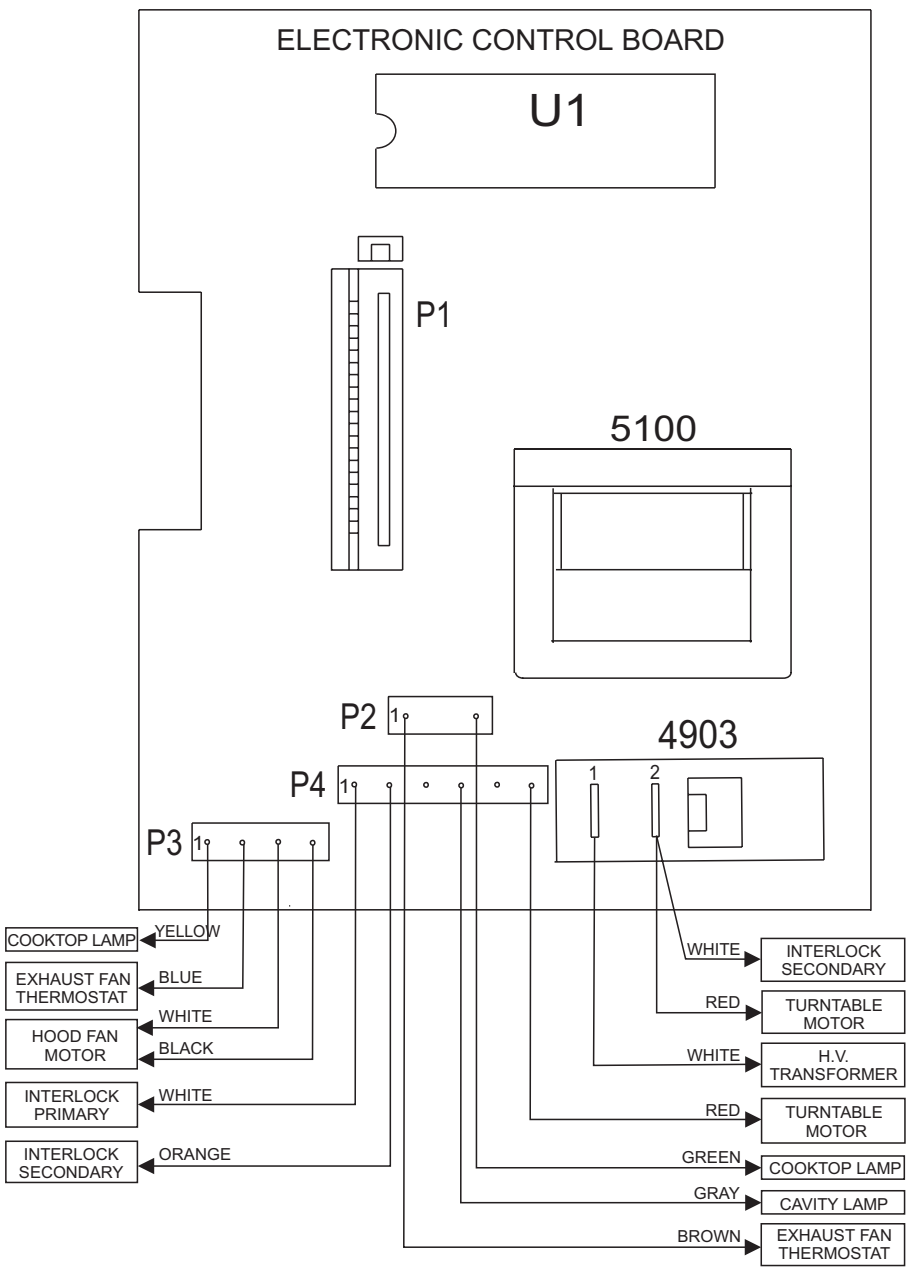

DWG NO. L-M1-071

**PARTS LAYOUT**

Not to Scale

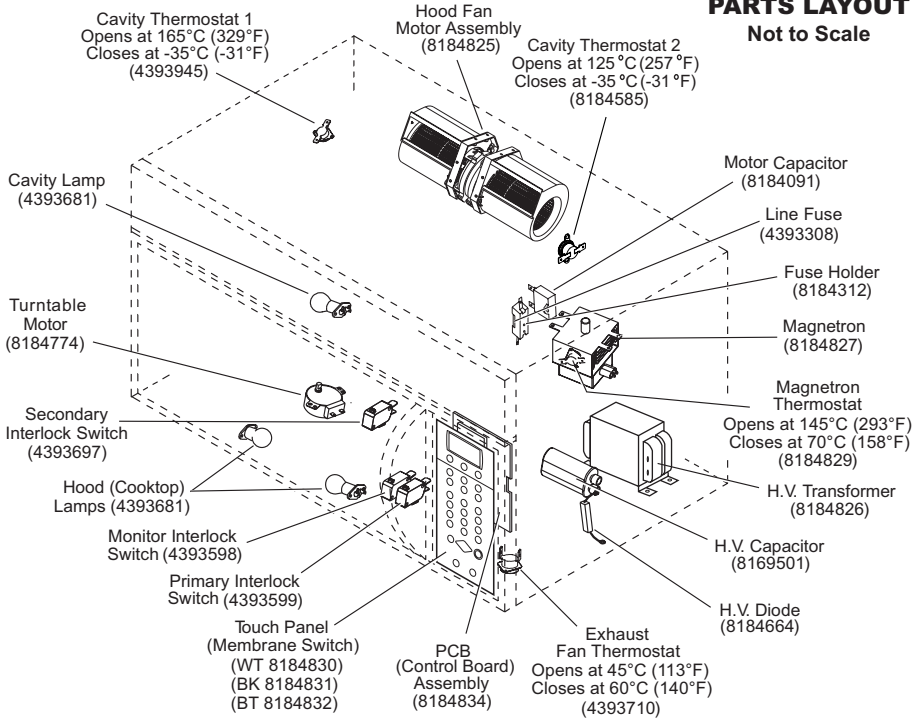

**PRIMARY, SECONDARY, AND MONITOR INTERLOCK SWITCH CHECKOUT PROCEDURE**

Switch	Check By	Door Open	Door Closed
<b>Primary Interlock</b>	Disconnect the wires at the Primary Interlock Switch. Check from the common terminal (White/Brown wires) to the normally open terminal (White wires).	-	+
<b>Secondary Interlock</b>	Disconnect the wires at the Secondary Interlock Switch. Check from the common terminal (Black wires) to the normally open terminal (White wire).	-	+
	Disconnect the wires at the Secondary Interlock Switch. Check from the common terminal (Black wires) to the normally closed terminal (Orange wire).	+	-
<b>Monitor</b>	Disconnect the wires at the Monitor Switch. Check from the common terminal (White/Blue wires) to the normally closed terminal (Red wires).	+	-

(+) Continuity (-) No Continuity

**NOTE:** These diagrams are not intended to show a complete circuit; they represent the position of switches during "DOOR OPEN" and "DOOR CLOSED" (continuity checks only).

**DOOR CLOSED**

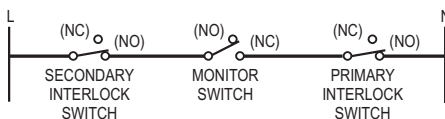

**DOOR OPEN**

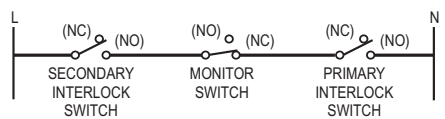

**TOUCH PANEL CONTINUITY DIAGRAM**

**Example of use:**

When "Cook Time" is selected, a resistance of less than 200 ohms will be observed between 3 and 11 on the flex circuit connector. See diagram at right.

**14 PIN FLEX CIRCUIT CONNECTOR**

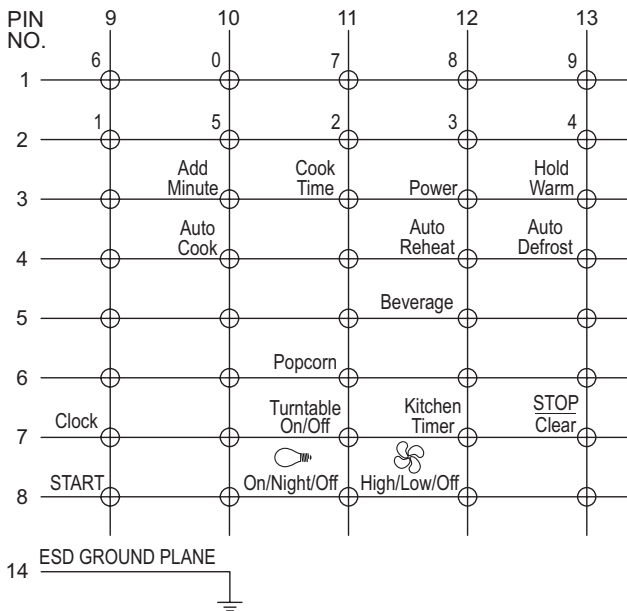
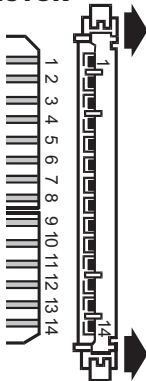

**TOUCH PANEL AND MICROCOMPUTER BOARD TEST**

The microwave hood combination is provided with a self-diagnostic routine that can be accessed through the touch key pad. To initiate this routine:

1. Depress the STOP/Clear button while opening the door and while still depressing the STOP/Clear button, unplug the microwave oven for two seconds and plug it back in.

2. Release the STOP/Clear button and then close the door.
3. Now, by pressing each button on the control panel, the number 8 will appear in the display to indicate that the circuits are complete and all relays are working.

**NOTE:** If the STOP/Clear button is pressed during this diagnostic routine, you will exit the test mode.

**KEY TABLE FOR TEST MODE**

Key Name	In Circuit Relay	Digit*
Popcorn	-	1
Beverage	-	3
Hold Warm	-	5
Auto Cook	-	1
Auto Defrost	-	3
Auto Reheat	-	5
Cook Time	-	1
Power	-	3
Add Minute	-	5
1	4901 (Cavity Light/Door)	1
2	4911 (Hood Light)	3
3	4903 (MW)	5
4	-	1
5	-	3
6	4906 (Turntable) 4901 (Cavity Light/Door)	5

Key Name	In Circuit Relay	Digit*
7	-	1
8	4912 (Night Light)	3
9	4909 (Fan High/Low)	5
Clock	Buzzer	1
0	4910 (Fan On/Off)	3
Kitchen Timer	-	5
START	-	1
Turntable On/Off	-	3
(Fan) High/Low/Off	-	2
(Light) On/Night/Off	-	4
STOP/Clear	-	See Text

\* The No. 8 will appear in the display position indicated in the table.

### TROUBLESHOOTING GUIDE

Complete the following steps before checking microwave circuitry:

1. Check the line voltage, household fuses or circuit breakers.
2. Check for loose wiring or miswiring within microwave.
3. Disconnect white wire from power transformer and discharge high-voltage capacitor.

4. All testing must be done with an ohmmeter having a sensitivity of 20,000 ohms per volt DC or greater, and powered by at least a 9-volt battery.
5. All operational checks using microwave energy must be done with the microwave oven loaded with a minimum of 300 ml (10 oz.) of water in a microwave-safe container.

### MICROWAVE COOKING

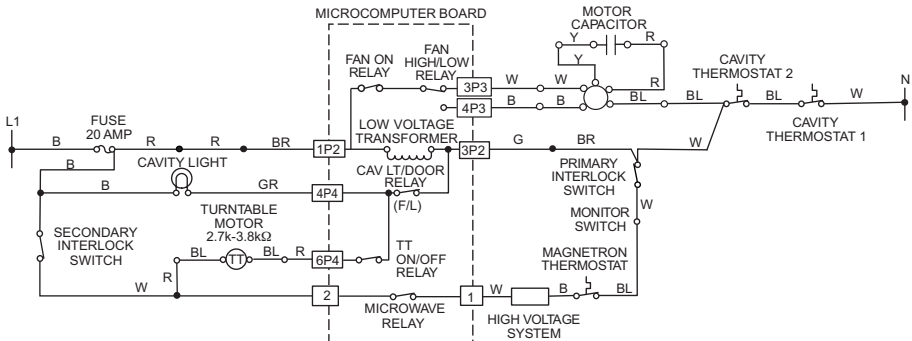

### BLOWER FAN TURNS ON AUTOMATICALLY

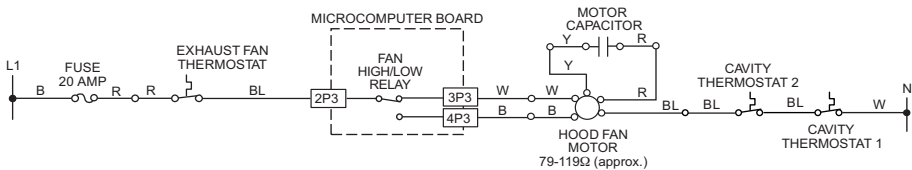

### BLOWER FAN ON HIGH

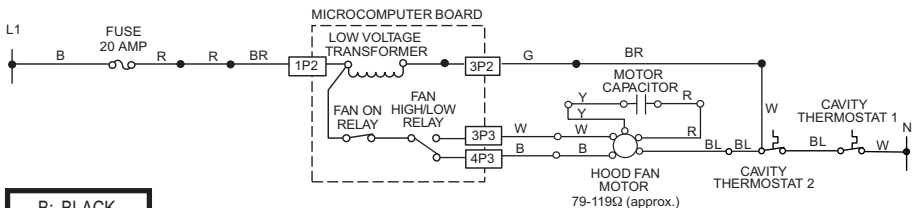

- B: BLACK
- BL: BLUE
- BR: BROWN
- G: GREEN
- R: RED
- W: WHITE
- Y: YELLOW

**BLOWER FAN ON LOW**

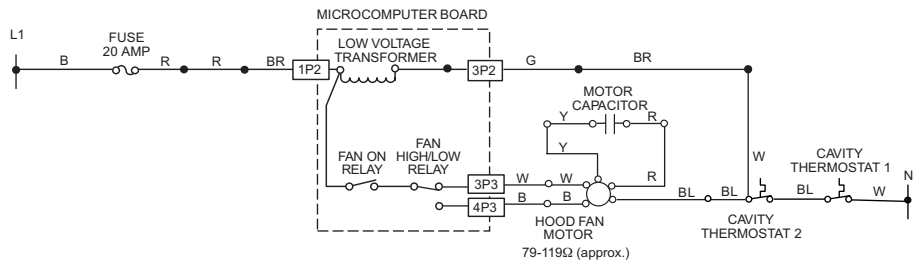

**MICROWAVE PLUGGED IN - TIME OF DAY DISPLAYED**

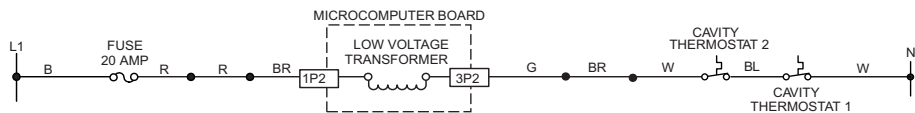

**DOOR OPEN - CAVITY LIGHT IS ON**

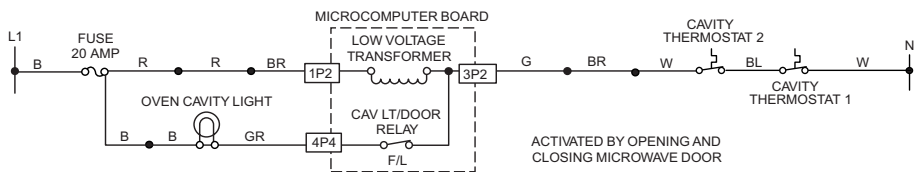

- B: BLACK
- BL: BLUE
- BR: BROWN
- G: GREEN
- R: RED
- W: WHITE
- Y: YELLOW



**COOKTOP LIGHT ON HIGH**

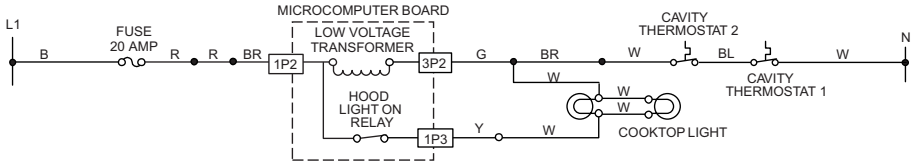

**COOKTOP LIGHT ON LOW (NIGHT LIGHT)**

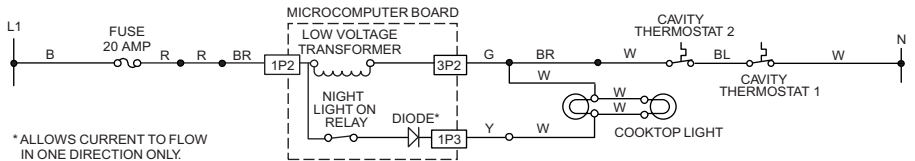

\* ALLOWS CURRENT TO FLOW IN ONE DIRECTION ONLY.

- B: BLACK
- BL: BLUE
- BR: BROWN
- G: GREEN
- R: RED
- W: WHITE
- Y: YELLOW

**COMPONENT TESTS**

Discharge the high-voltage capacitor and remove the lead wires from the primary winding of the high voltage transformer before conducting any of the following tests.

All operational checks using microwave energy must be done with the microwave oven loaded with a minimum of 300 ml (10 oz.) of water in a microwave-safe container.



Conduct a microwave energy test after performing any tests or repairs to the microwave.

Check that all wire leads are in the correct position before operating the microwave oven.

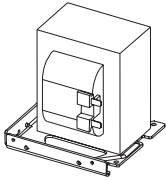
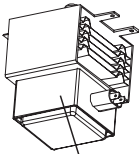
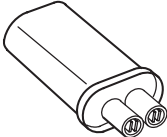
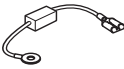
Grasp wire connectors when removing the wire leads from microwave parts.

COMPONENT	TEST	RESULTS
<b>H.V. Transformer</b> 	1. Remove wire leads.	
	2. Measure resistance (ohmmeter scale: Rx1): Primary winding - Secondary winding - Filament winding -	- Less than 0.5 ohm (approx.) - 100 ohms (approximate) - 0 ohms
	3. Measure resistance (ohmmeter scale: Rx1k): Primary winding to grounding - Filament winding to grounding -	- Normal: Infinite - Normal: Infinite
<b>Magnetron</b>  Chassis	1. Remove wire leads. Check that the seal is in good condition.	
	2. Measure resistance (ohmmeter scale: Rx1): Filament terminal -	- Normal: Less than 1 ohm
	3. Measure resistance (ohmmeter scale: Rx1k): Filament to chassis -	- Normal: Infinite
<b>H.V. Capacitor</b> 	1. Discharge capacitor.	
	2. Remove wire leads.	
	3. Measure resistance (ohmmeter scale: Rx1k): Terminal to terminal -  Terminal to case -	- Normal: Momentarily indicates several ohms, gradually returns to Infinite  - Normal: Infinite
<b>H.V. Diode</b>  (Some inexpensive meters may indicate infinite resistance, both directions.)	1. Measure continuity (ohmmeter scale: Rx1k): Forward -	- Normal: Continuity - Abnormal: Infinite
	2. Measure continuity (ohmmeter scale: Rx1k): Reverse -	- Normal: Infinite - Abnormal: Continuity

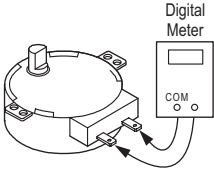
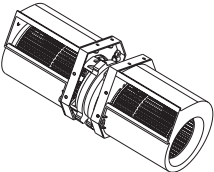
CONTINUED ...

COMPONENT	TEST	RESULTS
<p><b>Turntable Motor</b></p> 	<ol style="list-style-type: none"> <li>1. Remove wire leads.</li> <li>2. Measure resistance (ohmmeter scale: Rx1k):</li> </ol>	<ul style="list-style-type: none"> <li>- Normal: 2.7k - 3.8k ohms (approximate)</li> <li>- Abnormal: Infinite</li> </ul>
<p><b>Hood Fan Motor</b></p> 	<ol style="list-style-type: none"> <li>1. Remove wire leads.</li> <li>2. Measure resistance (ohmmeter scale: Rx1):                         <ul style="list-style-type: none"> <li>For High Speed:                                 <ul style="list-style-type: none"> <li>Red and Blue wires</li> <li>Blue and Black wires</li> </ul> </li> <li>For Low Speed:                                 <ul style="list-style-type: none"> <li>Red and Blue wires</li> <li>Blue and White wires</li> </ul> </li> </ul> </li> </ol>	<ul style="list-style-type: none"> <li>- Normal:                             <ul style="list-style-type: none"> <li>79 - 119 ohms (approximate)</li> <li>22 - 43 ohms (approximate)</li> </ul> </li> <li>- Abnormal: Infinite</li> </ul>
<p><b>Thermostats</b></p> <p>Cavity/Magnetron Thermostat</p>  <p>.....</p> <p>Exhaust Fan Thermostat</p> 	<p><b>NOTE:</b> Refer to Parts Layout on page 5 for opening and closing temperatures.</p> <ol style="list-style-type: none"> <li>1. Remove wire leads.</li> <li>2. <b>Cavity and Magnetron Thermostats:</b> Measure continuity (ohmmeter scale: Rx1):</li> <li>3. <b>Exhaust Fan Thermostat:</b> Measure continuity (ohmmeter scale: Rx1):</li> </ol>	<ul style="list-style-type: none"> <li>- Normal: Continuity</li> <li>- Abnormal: Infinite</li> </ul> <ul style="list-style-type: none"> <li>- Normal: Infinite</li> <li>- Abnormal: Continuity</li> </ul>

This page is intentionally blank.