



EMI TEST REPORT

BWS Tech, Inc.

294-9, Jungdae-Dong, Gwangju-City, Gyeonggi-Do 464-080 Korea
TEL: 82 31 764 0125 FAX: 82 31 764 0126

Date of Test : February 06, 2002
Test Report No. : BWS-03-EF-0005
Test Site : BWS Tech., Inc. (Registration No. : 553281)

Trade Name : N/A
Applicant : Digital Device Inc.
Address : 4th FL. Hanhwa B/D, 78-1 Karakbon-Dong, Songpa-Gu, Seoul, Korea.

Contact Person : InHO, Cheong
Tel No. : 82-2-431-8471
Fax No. : 82-2-431-8472

Product Name : 42 inch Plasma Display Monitor
Model Name : DPD-4210
FCC ID : PQZDPD-4210
FCC Rule Part(s) : FCC Part 15 Subpart B Class B
Classification : Part 15 Class B Computing Device Peripheral (JBP)

The device bearing the trade name and model specified above has been complied with the applicable technical standards as described in this test report and was tested in accordance with the measurement procedures specified in ANSI C.63.4-2000.

I attest to the accuracy of data and all measurement reported herein were performed by our test personnel were made under my supervision.
I assume the responsibility for the completeness of these measurements and for the qualification of all our personnel conducting this testing.

Feb. 06, 2003

K. Young Kim
Chief Engineer
Laboratory Division



TABLE OF CONTENTS

	Pages
1. Description of Device	3
1.1 General	3
1.2 EUT Description	3
2. Test facility	4
3. Summary of results	4
3.1 Electromagnetic Emission	4
3.2 Modifications to the EUT	4
4. Tested system details	5
4.1 Peripherals and Others	5
4.2 Type of Cables Used	5
4.3 System layout on EUT and peripherals	6
5. Test result	7
5.1 RFI Voltage Measurement	7~10
5.2 RFI Field Strength Measurement	11~12
5.3 Minimum Margin	13
5.4 Sample Calculations	13
6. Test Equipments	14
Appendix 1. External Photos of EUT	
Appendix 2. Internal Photos of EUT	
Appendix 3. Test Setup Photos	
Appendix 4. FCC ID Label and location	
Appendix 5. Block Diagram	
Appendix 6. User Manual	



1. DESCRIPTION OF DEVICE

1.1 General

Applicant	Digital Device Inc. 4 th FL. Hanhwa B/D, 78-1 Karakbon-Dong, Songpa-Gu, Seoul, Korea.
Contact Person	InHO, Cheong Tel No. : 82-2-431-8471 Fax No. : 82-2-431-8472

- Trade name **Digital Device Inc.**
- Model name **DPD-4210**
- EUT Type **42 inch Plasma Display Monitor**
- Classification **Part 15 Class B Computing Device Peripheral (JBP)**
- Clock Speed **20.2 MHz, 12 MHz**
- Rule Part(s) **FCC Part 2 & Part 15 Subpart B Class B**
- Test Procedure(s) **ANSI C63.4-2000**
- Date of Tests **February 06, 2003**
- Test Lab **BWS Tech, Inc.**

1.2 EUT Descriptions

This equipment is the PDP Monitor with its ultra slim design, PDP can be placed anywhere to let you enjoy multimedia contents. It is the perfect multimedia display terminal with direct connections to PCs, Terrestrial / CABLE / Satellite receivers, DVD players, TV RF, Camcorders, and more.

Note. This report may be reproduced in full pages. Partial reproduction may only be made with the written permission of BWS Tech laboratory. The test results in this report are only applied to the sample(s) tested.

Note. Please refer to the duties and responsibilities of the Responsible Party attached.



2. TEST FACILITY

The open field test site and conducted measurement facility used for this measurement, is located following address. This site was fully described in a report dated Dec. 26, 2001 that was submitted to the FCC. Our site and facility had been accepted in a letter dated Dec. 26, 2001(Registration No. : 553281) :

BWS Tech, Inc.
Address : 294-9, Jungdae-Dong, Gwangju-City, Gyeonggi-Do 464-080 Korea

The detailed description of the measurement facility was found to be in compliance with the requirements of §2.948 according to ANSI C63.4 on Dec. 08, 2000.

3. SUMMARY OF RESULTS

3.1 Electromagnetic Emission

RFI Voltage Measurement **PASS**

RFI Field Strength Measurement **PASS**

Although the measured emissions indicate that the EUT complies with the required limits, some measurement s are close to these limits.

When the uncertainty of measurement is considered, there is a possibility that the EUT may not be compliant.

3.2 Modifications to the EUT : None



FCC TEST REPORT

Model No. : DPD-4210
Test Report No. : BWS-03-EF-0005

4. TESTED SYSTEM DETAILS

4.1 Peripherals and Others :

Description	Model Name	Serial No.	Manufacturer	FCC ID
Computer(Test 7)	VDHM(Optiplex GX240)	-	Dell	DoC
42 inch Plasma Display Monitor	DPD-4210	-	Digital Device Inc	EUT
Keyboard	SK-8110	04N730	SILITEK	AQ6-22K15
PS2 Mouse	M-SAW34	LZE21070672	SUZHOU	DZL211029
Serial Mouse #1	OK-720	-	A4 TECH	DoC
Serial Mouse #2	OK-520	-	A4 TECH	FSUGMZC7
Joystick	-	-	Microsoft	DoC

4.2 Type of Cables Used:

Device from	Device to	Type of Cable	Length	Type of shield
Computer	PS/2 (Keyboard)	Signal cable	1.0	Shielded
Computer	PS/2 (Mouse)	Signal cable	1.0	Shielded
Computer	SERIAL (Mouse #1, #2)	Signal cable	1.0	Shielded
Computer	MIDI (Joystick)	Signal cable	1.2	Shielded
EUT	VIDEO (Computer)	Signal cable	1.0	Shielded
Power Cable	Power	-	1.5	Unshielded

4.3 System layout on EUT and peripherals

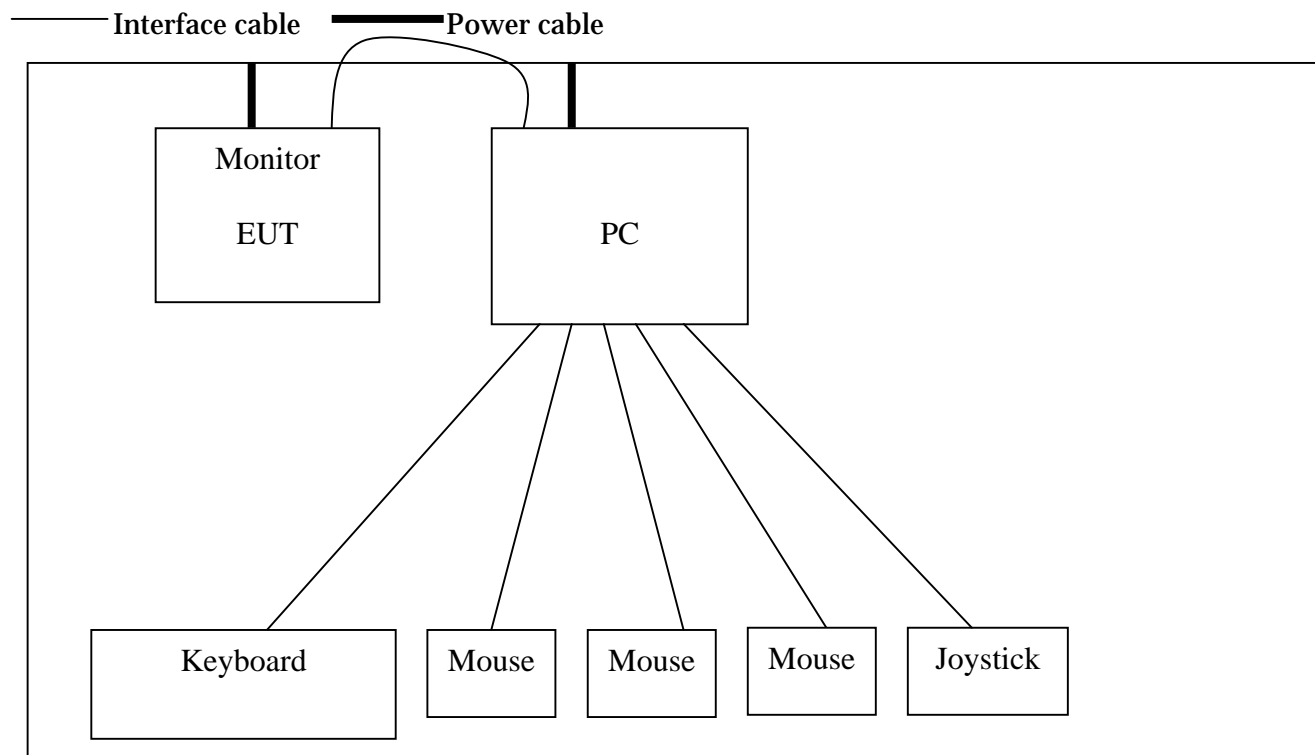

<Figure 4-1 System layout>



5. TEST RESULT

5.1 RFI Voltage Measurement

5.1.1 Measurement Instrumentation Used

Equipment Type	Model	Manufacture	Serial No	Cal Date	Use
EMI Receiver	ESH3	ROHDE & SCHWARZ	892580/014	2002. 06. 01	<input checked="" type="checkbox"/>
Signal Analyzer	PMM9000	PMM	3100570602	2002. 08. 16	<input type="checkbox"/>
Artificial Mains Network	KNW-242C	KYORITSU	8-920-20	2002. 08. 19	<input checked="" type="checkbox"/>
Artificial Mains Network	L3-25	PMM	1110K70403	2002. 09. 01	<input checked="" type="checkbox"/>
Coaxial Cable	RG213U	MARLOW	N/A	N/A	<input checked="" type="checkbox"/>

5.1.2 Measurement Procedure

The power line conducted interference measurement were performed according to ANSI C63.4-2000 in a Shielded room placed on a table, 0.8 m high over a metal floor. It was located more than required distance away from the shielded enclosure wall. There is no deviation from the standard. The EUT was plugged into the LISN and the frequency range of interest scanned. **We conducted measurement in 'worst case' emission mode.** We reported at maximum emission levels.

5.1.3 Operation Modes

EUT was tested according to the video resolution specifications given by the manufacturer, and reported the worst emissions. The following resolution modes were investigated.

5.1.4 Measurement Uncertainty

Measurement uncertainty of RFI Voltage Measurement test was estimated at ± 3.51 dB(k=2)



FCC TEST REPORT

Model No. : DPD-4210
Test Report No. : BWS-03-EF-0005

5.1.5 Test Data

RFI Voltage Measurement Results (0.15 MHz to 30 MHz)

Operating mode : Normal mode
Test procedure : ANSI C63.4-2000

Date of measurement : February 06, 2003
Temperature : 22 degree C
Humidity : 33 %

Model : **DPD-4210**

FREQ(MHz)	LEVEL(dBuV)	LINE	LIMIT(dBuV)	Result(dBuV)	MARGIN(dBuV)
0.160	43.20	N	65.7	43.20	-22.50
0.174	31.70	H	65.4	31.70	-33.70
2.386	34.50	H	56.00	34.50	-21.50
2.653	35.00	H		35.00	-21.00
2.932	35.50	N		35.50	-20.50
3.222	34.00	N		34.00	-22.00
4.325	32.00	N		32.00	-24.00
6.840	42.00	H		60.00	42.00
7.700	39.20	H	39.20		-20.80
8.460	39.00	H	39.00		-21.00
15.240	45.20	H	45.20		-14.80
16.260	41.50	H	41.50		-18.50
23.290	44.50	H	44.50		-15.50

Table 1. Line Conducted Emission Tabulated Data

Note :

- All modes of operation were investigated and the worst-case emissions are reported.
See attached Plots.
- The limit for Class B digital device is 2000-630 $\mu\text{V}/\text{m}$ (66-56 $\text{dB}\mu\text{V}/\text{m}$) from 0.15 MHz to 0.5 MHz, 630 $\mu\text{V}/\text{m}$ (56 $\text{dB}\mu\text{V}/\text{m}$) from 0.5 MHz to 5 MHz, 1000 $\mu\text{V}/\text{m}$ (60 $\text{dB}\mu\text{V}/\text{m}$) from 5 MHz to 30 MHz
- Line H = Hot , Line N = Neutral

** Measurement using CISPR quasi-peak mode

Tested by *Shim Min-Seob*



FCC TEST REPORT

Model No. : DPD-4210
Test Report No. : BWS-03-EF-0005

PLOTS OF EMISSIONS

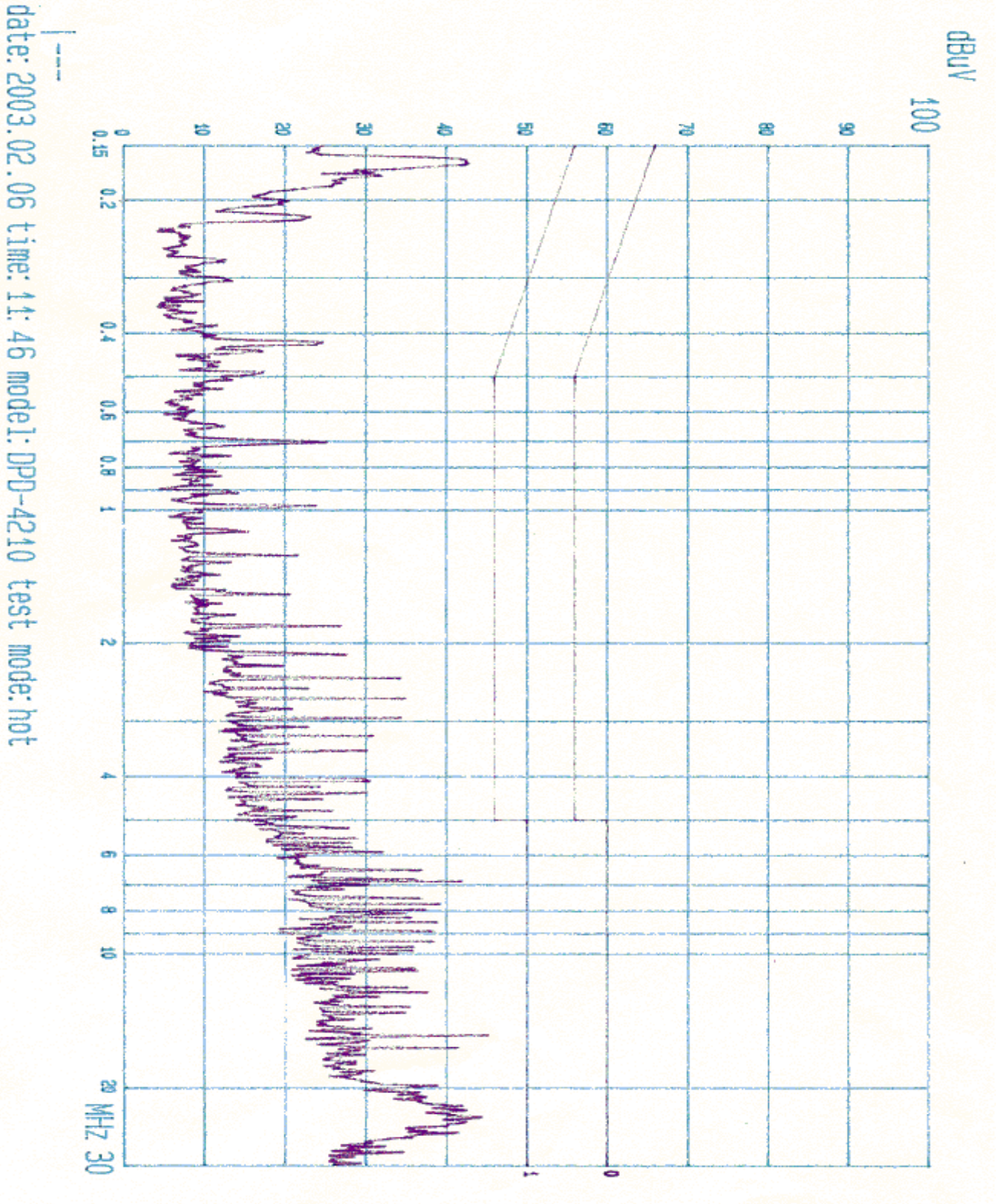



FCC TEST REPORT

Model No. : DPD-4210
Test Report No. : BWS-03-EF-0005

PLOTS OF EMISSIONS

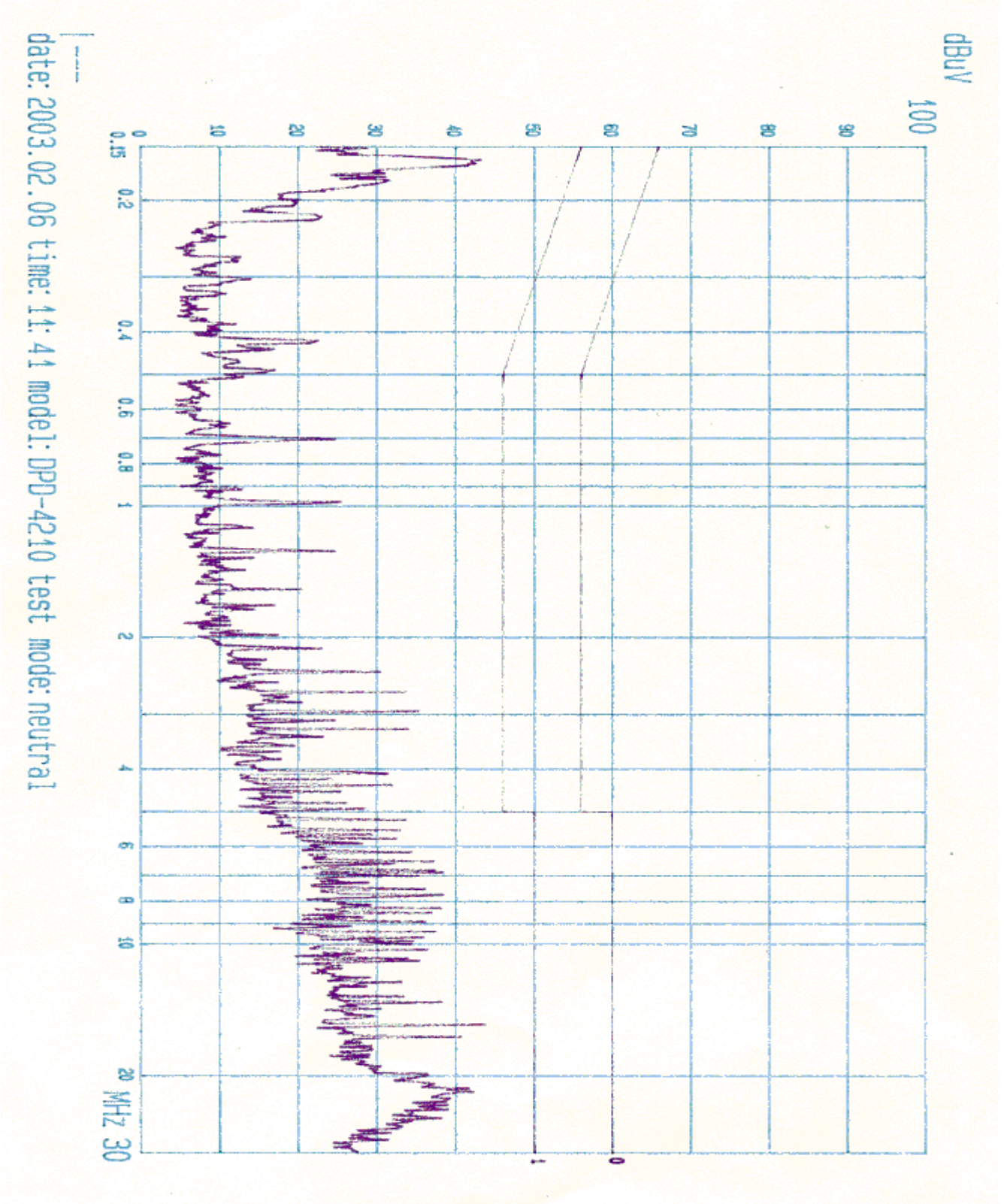



5.2 RFI Field Strength Measurement

5.2.1 Measurement Instrumentation Used

Equipment Type	Model	Manufacture	Serial No	Cal Date	Use
Signal Analyzer	PMM9000	PMM	3100570602	2002. 08. 16	<input checked="" type="checkbox"/>
SPECTRUM ANALYZER	R3261C	ADVANTEST	61720002	2002. 08. 22	<input checked="" type="checkbox"/>
LOG PERIODIC ANT	UPA6109	SCHAFFNER	1076	2002. 09. 06	<input checked="" type="checkbox"/>
BICONICAL ANT	BBA9106	SWALZBECK	N/A	2002. 09. 06	<input checked="" type="checkbox"/>
AMPLIFIER	8447E	HP	2945A02712	2002. 08. 19	<input checked="" type="checkbox"/>
Antenna Mast	JAC-1	DAIL EMC	DAIL EMC	N/A	<input checked="" type="checkbox"/>
Antenna Turntable Controller	JAC-2	JAEMC	N/A	N/A	<input checked="" type="checkbox"/>
Coaxial cable	RG213U	MARLOW	N/A	N/A	<input checked="" type="checkbox"/>

5.2.2 Measurement Procedure

Final test was performed according to ANSI C63.4-2000 at the open field site .

Deviations from the standard were none.

The EUT was placed in a 0.8 m high table along with the peripherals. The turn table was separated from the antenna with the distance of 3 meter. Cables were placed in a position to produce maximum emissions as determined by experimentation, and operation mode was selected for maximum.

The frequencies and amplitudes of maximum emission were measured at varying azimuths, antenna heights and antenna polarities. **We measured device in 'worst case' condition mode.** We gathered data at maximum emission levels.

5.2.3 Operation Modes

EUT was tested according to the video resolution specifications given by the manufacturer, and reported the worst emissions. The following resolution modes were investigated.

5.2.4 Measurement Uncertainty

Measurement uncertainty of RFI Field Strength Measurement test was estimated at ± 4.34 dB(k=2)



FCC TEST REPORT

Model No. : DPD-4210
Test Report No. : BWS-03-EF-0005

5.2.5 Test Data

RFI Field Strength Measurement Results(30 MHz to 1000 MHz)

Operating mode : Normal Mode

Date of measurement : February 06, 2003

Test procedure : ANSI C63.4-2000

Temperature : 3 degree C

Humidity : 21 %

Model : **DPD-4210**

MEASEMENT FREQ (MHz)	MEASEMENT LEVEL (dBuV)	ANTENNA POLARITY (H/V)	ANTENNA FACTOR (dB)	CABLE LOSS (dB)	LIMIT (dBuV)	FIELD STRENGTH (dBuV/m)	MARGIN (dBuV/m)
37.73	22.30	V	12.60	1.27	40.00	36.17	-3.83
41.69	20.00	V	13.69	2.61		36.30	-3.70
49.61	23.50	V	9.73	1.38		34.61	-5.39
127.97	18.20	V	12.52	2.30	43.5	33.02	-10.48
174.95	15.00	V	13.40	2.74		31.14	-12.36
199.96	18.00	V	14.28	2.93		35.21	-8.29
255.97	22.50	H	12.19	3.42	46	38.11	-7.89
383.98	21.00	H	15.48	4.18		40.66	-5.34
411.98	19.00	H	15.97	4.35		39.32	-6.68
639.97	13.00	H	20.68	5.56		39.24	-6.76
767.97	12.50	V	22.43	6.27		41.20	-4.80
895.97	10.80	V	24.69	6.27		41.76	-4.24

Table 2. Radiated Measurements at 3meters.

Note :

- All modes of operation were investigated and the worst-case emissions are reported.
- The limit for Class B digital device is 100 $\mu\text{V}/\text{m}$ (40.0 dB $\mu\text{V}/\text{m}$) from 30 MHz to 88 MHz, 150 $\mu\text{V}/\text{m}$ (43.5 dB $\mu\text{V}/\text{m}$) from 88 MHz to 216 MHz, 200 $\mu\text{V}/\text{m}$ (46.0 dB $\mu\text{V}/\text{m}$) from 216 MHz to 960 MHz and 500 $\mu\text{V}/\text{m}$ (53.98 dB $\mu\text{V}/\text{m}$) from above 960 MHz.

* Measurements were performed using CISPR quasi-peak mode. Above 1 GHz, peak detector function mode was used with a resolution bandwidth of 1 MHz and a video bandwidth of 1 MHz.

The peak level complies with the average limit. Peak mode is used with linearly polarized horn antenna and low-loss microwave cable.

Tested by *Shim Min-Seob*



FCC TEST REPORT

Model No. : DPD-4210
Test Report No. : BWS-03-EF-0005

5.3 Minimum Margin

Conducted emission

DPD-4210 Normal mode 15.24 MHz, 14.80 dB

Radiated emission

DPD-4210 Normal mode 41.69 MHz, 3.70 dB

5.4 SAMPLE CALCULATIONS

$$\text{dB}\mu\text{V} = 20 \log_{10} (\mu\text{V}/\text{m})$$
$$\mu\text{V} = 10^{(\text{dB}\mu\text{V}/20)}$$

EX. 1.

@ 15.24 MHz Class B limit = 60 dB μ V

Reading = 45.20 dB μ V (calibrated level)

Margin = 45.20 - 60 = -14.80

14.80 dB ; below limit

EX. 2.

@ 41.69 MHz Class B limit = 40.0 dB μ V/m

Reading = 20.0 dB μ V(calibrated level)

Antenna factor + Cable Loss = 16.3 dB

Total = 36.3dB μ V/m

Margin = 36.3 - 40 = -3.7 dB

3.7 dB ; below limit

6. TEST EQUIPMENTS



FCC TEST REPORT

Model No. : DPD-4210
Test Report No. : BWS-03-EF-0005

The listing below denotes the test equipments utilized for the test(s).

<u>Nomenclature</u>	<u>Manufacture Model Number</u>	<u>Serial Number</u>	<u>Calibration Date</u>
Signal Analyzer	PMM PMM9000	3100570602	02/08/16
EMC Analyzer	HP E7403A	US39150108	02/02/19
EMI Receiver	ESH3 ROHDE & SCHWARZ	892580/014	02/06/01
Spectrum Analyzer	ADVANTEST R3261C	61720002	02/08/22
Amplifier (0.1MHz-1.3GHz)	HP 8447E	2945A02712	02/08/19
Biconical Antenna	SWALZBECK BBA9106	N/A	02/09/12
Log Periodic Antenna	SCHAFFNER UPA6109	N/A	02/09/12
Plotter	HP 7475A	007475A	N/A
Shield Room 7m x 4m x 4m	SEMITECH	000815	N/A
Turn Table	JAEMC JAC-2	N/A	N/A
Antenna Mast	Dae-il EMC JAC-1	N/A	N/A
Artificial Mains Network	PMM L3-25	1110K70403	02/10/02
Artificial Mains Network	KYORITSU KNW-242C	8-920-20	02/08/31
Antenna Turntable Controller	JAEMC JAC-2	N/A	N/A