



A D T

DFS TEST REPORT

REPORT NO.: RF120113E07B-2

MODEL NO.: FXE2000-G

FCC ID: PQRFXE2000-G

RECEIVED: Jan. 13, 2012

TESTED: Mar. 03, 2012

ISSUED: June 12, 2012

APPLICANT: Contec Co., Ltd.

ADDRESS: 3-9-31, Himesato, Nishiyodogawa-ku Osaka
Japan 555-0025

ISSUED BY: Bureau Veritas Consumer Products Services
(H.K.) Ltd., Taoyuan Branch Hsin Chu Laboratory

LAB ADDRESS : No. 81-1, Lu Liao Keng, 9th Ling, Wu Lung Tsuen,
Chiung Lin Hsiang, Hsin Chu Hsien 307, Taiwan,
R.O.C.

TEST LOCATION (1): No. 81-1, Lu Liao Keng, 9th Ling, Wu Lung Tsuen,
Chiung Lin Hsiang, Hsin Chu Hsien 307, Taiwan,
R.O.C.

TEST LOCATION (2): No. 49, Ln. 206, Wende Rd., Shangshan Tsuen,
Chiung Lin Hsiang, Hsin Chu Hsien 307, Taiwan,
R.O.C.

This report should not be used by the client to claim
product certification, approval, or endorsement by
TAF or any government agencies.



This report is for your exclusive use. Any copying or replication of this report to or for any other person or entity, or use of our name or trademark, is permitted only with our prior written permission. This report sets forth our findings solely with respect to the test samples identified herein. The results set forth in this report are not indicative or representative of the quality or characteristics of the lot from which a test sample was taken or any similar or identical product unless specifically and expressly noted. Our report includes all of the tests requested by you and the results thereof based upon the information that you provided to us. You have 60 days from date of issuance of this report to notify us of any material error or omission caused by our negligence, provided, however, that such notice shall be in writing and shall specifically address the issue you wish to raise. A failure to raise such issue within the prescribed time shall constitute your unqualified acceptance of the completeness of this report, the tests conducted and the correctness of the report contents. Unless specific mention, the uncertainty of measurement has been explicitly taken into account to declare the compliance or non-compliance to the specification



Table of Contents

RELEASE CONTROL RECORD.....	4
1. CERTIFICATION	5
2. EUT INFORMATION	6
2.1 OPERATING FREQUENCY BANDS AND MODE OF EUT.....	6
2.2 EUT SOFTWARE AND FIRMWARE VERSION	6
2.3 DESCRIPTION OF AVAILABLE ANTENNAS TO THE EUT	7
2.4 EUT MAXIMUM CONDUCTED POWER	8
2.5 EUT MAXIMUM EIRP POWER	9
2.6 TRANSMIT POWER CONTROL (TPC).....	10
2.7 STATEMENT OF MAUNFACTURER	10
3. U-NII DFS RULE REQUIREMENTS	11
3.1 WORKING MODES AND REQUIRED TEST ITEMS	11
3.2 TEST LIMITS AND RADAR SIGNAL PARAMETERS	12
4. TEST & SUPPORT EQUIPMENT LIST	15
4.1 TEST INSTRUMENTS	15
4.2 DESCRIPTION OF SUPPORT UNITS.....	15
5. TEST PROCEDURE	16
5.1 BVADT DFS MEASUREMENT SYSTEM:	16
5.2 CALIBRATION OF DFS DETECTION THRESHOLD LEVEL:.....	17
5.3 DEVIATION FROM TEST STANDARD	17
5.4 CONDUCTED TEST SETUP CONFIGURATION.....	18
5.4.1 MASTER MODE.....	18
5.4.2 SLAVE WITHOUT RADAR DETECTION MODE	18
6. TEST RESULTS.....	19
6.1 SUMMARY OF TEST RESULT	19
6.1.1 MASTER MODE	19
6.1.2 SLAVE WITHOUT RADAR DETECTION MODE	19
6.2 DETAIL TEST RESULTS.....	20
6.2.1. TEST MODE: DEVICE OPERATING IN MASTER MODE.	20
6.2.1.1 DFS DETECTION THRESHOLD.....	20
6.2.1.2 CHANNEL AVAILABILITY CHECK TIME	20
6.2.1.3 CHANNEL CLOSING TRANSMISSION AND CHANNEL MOVE TIME ...	29
6.2.1.4 NON- OCCUPANCY PERIOD	52
6.2.1.5 UNIFORM SPREADING.....	54
6.2.1.6 U-NII DETECTION BANDWIDTH.....	54
6.2.1.7 NON-CO-CHANNEL TEST	57
6.2.1.8 TRANSMIT POWER CONTROL (TPC).....	58



A D T

6.2.2. TEST MODE: DEVICE OPERATING IN CLIENT WITHOUT RADAR DETECTION MODE.....	59
6.2.2.1 DFS DETECTION THRESHOLD.....	59
6.2.2.2 CHANNEL CLOSING TRANSMISSION AND CHANNEL MOVE TIME ...	60
6.2.2.3 NON- OCCUPANCY PERIOD	61
7 INFORMATION ON THE TESTING LABORATORIES.....	64
8 APPENDIX-A.....	65
9 APPENDIX-B	66
10 APPENDIX-C	135



A D T

RELEASE CONTROL RECORD

ISSUE NO.	REASON FOR CHANGE	DATE ISSUED
RF120113E07B-2	Original release	June 12, 2012



A D T

1. CERTIFICATION

PRODUCT: Wireless LAN Adapter
BRAND NAME: CONTEC
MODEL NO.: FXE2000-G
TEST SAMPLE: R&D SAMPLE
APPLICANT: Contec Co., Ltd.
TESTED: Jan. 19 to Apr. 17, 2012
STANDARDS: FCC Part 15, Subpart E (Section 15.407)
FCC 06-96

The above equipment (Model: FXE2000-G) has been tested by **Bureau Veritas Consumer Products Services (H.K.) Ltd., Taoyuan Branch**, and was in compliance with the requirement of the above standards. The test record, data evaluation & Equipment Under Test (EUT) configurations represented herein are true and accurate accounts of the measurements of the sample's EMC characteristics under the conditions specified in this report.

PREPARED BY : Midoli Peng, **DATE:** June 12, 2012
(Midoli Peng, Specialist)

APPROVED BY : May Chen, **DATE:** June 12, 2012
(May Chen, Deputy Manager)

Note: This report is prepared for FCC class II change. Add the master mode in band <5250~5350MHz & 5.47~5.6GHz & 5.65~5.725GHz>



2. EUT INFORMATION

2.1 OPERATING FREQUENCY BANDS AND MODE OF EUT

Table 1: Operating frequency bands and mode of EUT.

Operational Mode	Operating Frequency Range	
	5250~5350MHz	5470~5725MHz
Master	ü	ü
Slave without radar detection	ü	ü

2.2 EUT SOFTWARE AND FIRMWARE VERSION

Table 2: The EUT software/firmware version.

No.	Product	Model No.	Software/Firmware Version
1	Wireless LAN Adapter	FXE2000-G	1.03.06 (2012-02-24)



A D T

2.3 DESCRIPTION OF AVAILABLE ANTENNAS TO THE EUT

Table 3: Antenna list.

Set 1									
Brand	Model	Antenna Type	Peak Gain(dBi) (Exclude cable loss)	Net Gain (dBi) (Include cable loss)	Connector Type	Cable Length (cm)	Cable Loss (dB)	Transmitter Circuit	
FDK	AN1523	chip	2.4GHz: 2	2.4GHz: 0.6	U.FL	16	1.4	Chain (0) & Chain (1)	
			5GHz :1	5GHz :-0.4					
Set 2									
Brand	Model	Antenna Type	Peak Gain(dBi) (Exclude cable loss)	Net Gain (dBi) (Include cable loss)	Connector Type	Cable Length (cm)	Cable Loss (dB)	Total Cable Loss (dB)	Transmitter Circuit
Azure Solutions, Inc.	MR-1700-W	Vehicle	2.4GHz: 4	2.4GHz: 2.1695	Cable 1: R-SMA	Cable 1: 152	Cable 1: 0.9305	1.8305	Chain (0) & Chain (1)
					Cable 2: U.FL	Cable 2: 20	Cable 2: 0.9		
Set 3									
Brand	Model	Antenna Type	Peak Gain(dBi) (Exclude cable loss)	Net Gain (dBi) (Include cable loss)	Connector Type	Cable Length (cm)	Cable Loss (dB)	Total Cable Loss (dB)	Transmitter Circuit
Azure Solutions, Inc.	MR-6000	Vehicle	5GHz :4	5GHz: 0.7978	Cable 1: R-SMA	Cable 1: 152	Cable 1: 1.5022	3.2022	Chain (0) & Chain (1)
					Cable 2: U.FL	Cable 2: 20	Cable 2: 1.7		

When operating Ant Set 2 or Set 3, that should connect cable1 & cable2 together.

Note :

- The EUT incorporates a MIMO function. Physically, the EUT provides two completed transmitters and two receivers.

MODULATION MODE	TX/RX FUNCTION
802.11a	2Tx/2Rx
802.11n (20MHz)	2Tx/2Rx
802.11n (40MHz)	2Tx/2Rx

- For 802.11a :

Directional gain = gain of antenna element + 10 log (# of TX antenna elements)

Effective Legacy Gain (dBi)=3.81 for antenna set 3

Effective Legacy Gain (dBi)=2.61 for antenna set 1

- For 802.11n (20MHz) & 802.11n (40MHz):

Net Gain (dBi)= 0.7978 for antenna set 3 ;

Net Gain (dBi)= -0.4 for antenna set 1



2.4 EUT MAXIMUM CONDUCTED POWER

Table 4: The measured conducted output power.

802.11a

Ant Set	Frequency Band(MHz)	MAX. Power	
		Output Power(dBm)	Output Power(mW)
3	5250~5725MHz	17.96	62.559

802.11n HT20

Ant Set	Frequency Band(MHz)	MAX. Power	
		Output Power(dBm)	Output Power(mW)
3	5250~5725MHz	17.5	56.170

802.11n HT40

Ant Set	Frequency Band(MHz)	MAX. Power	
		Output Power(dBm)	Output Power(mW)
3	5250~5725MHz	17.61	57.660



A D T

2.5 EUT MAXIMUM EIRP POWER

Table 5: The EIRP output power list.

802.11a

Ant Set	Frequency Band(MHz)	MAX. Power	
		Output Power(dBm)	Output Power(mW)
3	5250~5725MHz	21.77	143.549

802.11n HT20

Ant Set	Frequency Band(MHz)	MAX. Power	
		Output Power(dBm)	Output Power(mW)
3	5250~5725MHz	18.3	64.565

802.11n HT40

Ant Set	Frequency Band(MHz)	MAX. Power	
		Output Power(dBm)	Output Power(mW)
3	5250~5725MHz	18.41	66.222



A D T

2.6 TRANSMIT POWER CONTROL (TPC)

U-NII devices operating in the 5.25-5.35 GHz band and the 5.47-5.725 GHz band shall employ a TPC mechanism. The U-NII device is required to have the capability to operate at least 6 dB below the mean EIRP value of 30 dBm. A TPC mechanism is not required for systems with an e.i.r.p. of less than 500 mW.

Maximum EIRP of this device is 143.549mW which less than 500mW, therefore it's not require TPC function.

2.7 STATEMENT OF MAUNFACTURER

Manufacturer statement confirming that information regarding the parameters of the detected Radar Waveforms is not available to the end user. And the device Slave without radar detection mode doesn't have Ad Hoc mode on DFS frequency band.



3. U-NII DFS RULE REQUIREMENTS

3.1 WORKING MODES AND REQUIRED TEST ITEMS

The manufacturer shall state whether the UUT is capable of operating as a Master and/or a Client. If the UUT is capable of operating in more than one operating mode then each operating mode shall be tested separately. See tables 1 and 2 for the applicability of DFS requirements for each of the operational modes.

Table 6: Applicability of DFS requirements prior to use a channel

Requirement	Operational Mode		
	Master	Client without radar detection	Client with radar detection
Non-Occupancy Period	ü	ü	ü
DFS Detection Threshold	ü	Not required	ü
Channel Availability Check Time	ü	Not required	Not required
Uniform Spreading	ü	Not required	Not required
U-NII Detection Bandwidth	ü	Not required	ü

Table 7: Applicability of DFS requirements during normal operation.

Requirement	Operational Mode		
	Master	Client without radar detection	Client with radar detection
DFS Detection Threshold	ü	Not required	ü
Channel Closing Transmission Time	ü	ü	ü
Channel Move Time	ü	ü	ü
U-NII Detection Bandwidth	ü	Not required	ü



A D T

3.2 TEST LIMITS AND RADAR SIGNAL PARAMETERS

DETECTION THRESHOLD VALUES

Table 8: DFS Detection Thresholds for Master Devices and Client Devices With Radar Detection.

Maximum Transmit Power	Value (See Notes 1 and 2)
≥ 200 milliwatt	-64 dBm
< 200 milliwatt	-62 dBm

Note 1: This is the level at the input of the receiver assuming a 0 dBi receive antenna.
Note 2: Throughout these test procedures an additional 1 dB has been added to the amplitude of the test transmission waveforms to account for variations in measurement equipment. This will ensure that the test signal is at or above the detection threshold level to trigger a DFS response.



Table 9: DFS Response Requirement Values

Parameter	Value
Non-occupancy period	Minimum 30 minutes
Channel Availability Check Time	60 seconds
Channel Move Time	10 seconds See Note 1.
Channel Closing Transmission Time	200 milliseconds + an aggregate of 60 milliseconds over remaining 10 second period. See Notes 1 and 2.
U-NII Detection Bandwidth	Minimum 80% of the UNII 99% transmission power bandwidth. See Note 3.

Note 1: The instant that the Channel Move Time and the Channel Closing Transmission Time begins is as follows:

- For the Short Pulse Radar Test Signals this instant is the end of the Burst.
- For the Frequency Hopping radar Test Signal, this instant is the end of the last radar Burst generated.
- For the Long Pulse Radar Test Signal this instant is the end of the 12 second period defining the Radar Waveform.

Note 2: The Channel Closing Transmission Time is comprised of 200 milliseconds starting at the beginning of the Channel Move Time plus any additional intermittent control signals required to facilitate a Channel move (an aggregate of 60 milliseconds) during the remainder of the 10 second period. The aggregate duration of control signals will not count quiet periods in between transmissions.

Note 3: During the U-NII Detection Bandwidth detection test, radar type 1 is used and for each frequency step the minimum percentage of detection is 90 percent. Measurements are performed with no data traffic.



PARAMETERS OF DFS TEST SIGNALS

Step intervals of 0.1 microsecond for Pulse Width, 1 microsecond for PRI, 1 MHz for chirp width and 1 for the number of pulses will be utilized for the random determination of specific test waveforms.

Table 10: Short Pulse Radar Test Waveforms.

Radar Type	Pulse Width (µsec)	PRI (µsec)	Number of Pulses	Minimum Percentage of Successful Detection	Minimum Number of Trials
1	1	1428	18	60%	30
2	1-5	150-230	23-29	60%	30
3	6-10	200-500	16-18	60%	30
4	11-20	200-500	12-16	60%	30
Aggregate (Radar Types 1-4)				80%	120

Table 11: Long Pulse Radar Test Waveform

Radar Type	Pulse Width (µsec)	Chirp Width (MHz)	PRI (µsec)	Number of Pulses per Burst	Number of Bursts	Minimum Percentage of Successful Detection	Minimum Number of Trials
5	50-100	5-20	1000-2000	1-3	8-20	80%	30

Table 12: Frequency Hopping Radar Test Waveform

Radar Type	Pulse Width (µsec)	PRI (µsec)	Pulses per Hop	Hopping Rate (kHz)	Hopping Sequence Length (msec)	Minimum Percentage of Successful Detection	Minimum Number of Trials
6	1	333	9	0.333	300	70%	30



A D T

4. TEST & SUPPORT EQUIPMENT LIST

4.1 TEST INSTRUMENTS

Table 1: Test instruments list.

DESCRIPTION & MANUFACTURER	MODEL NO.	BRAND	CALIBRATED DATE	CALIBRATED UNTIL
R&S Spectrum analyzer	FSP40	R&S	May 11, 2011	May 10, 2012
Signal generator	8645A	Agilent	Sep. 02, 2011	Sep. 01, 2012
Oscilloscope	TDS 5104	Tektronix	May 17, 2011	May 16, 2012

4.2 DESCRIPTION OF SUPPORT UNITS

This EUT was functioned as a Master & Slave device during the DFS test.

5. TEST PROCEDURE

5.1 BVADT DFS MEASUREMENT SYSTEM:

A complete ADT DFS Measurement System consists of two subsystems: (1) the Radar Signal Generating Subsystem and (2) the Traffic Monitoring Subsystem. The control PC is necessary for generating the Radar waveforms in Table 10, 11 and 12. The traffic monitoring subsystem is specified to the type of unit under test (UUT).

Conducted setup configuration of ADT DFS Measurement System

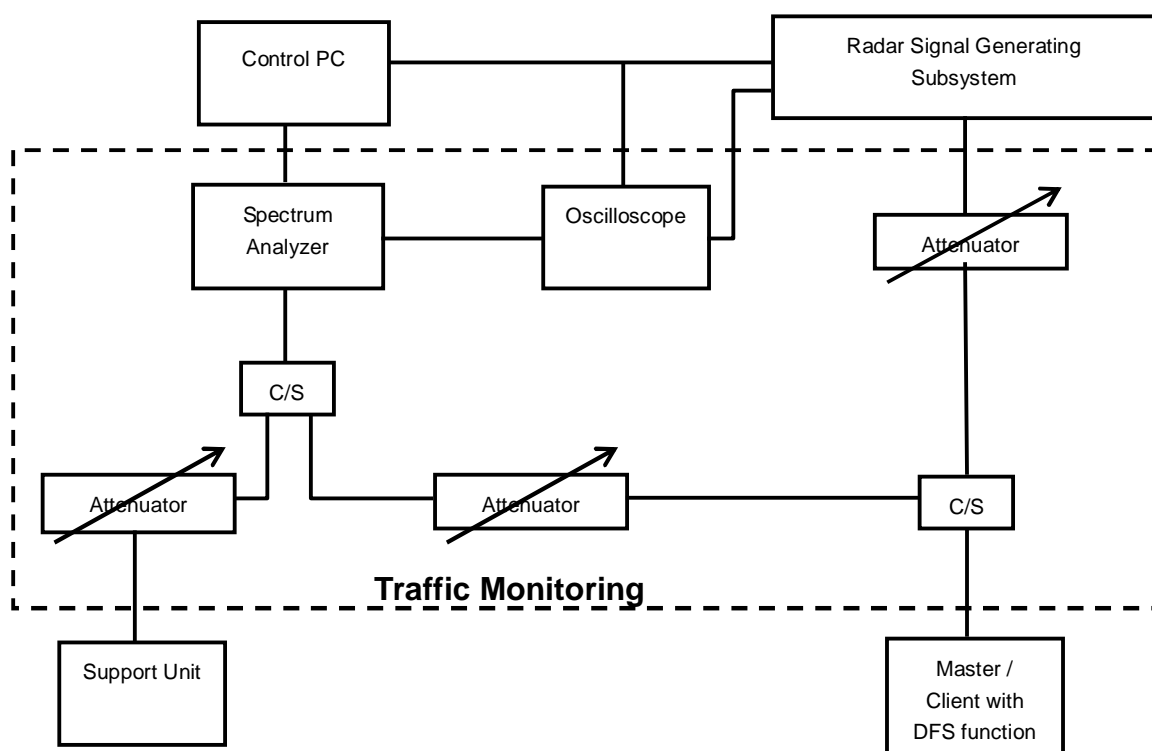

The test transmission will always be from the Master Device to the Client Device. While the Client device is set up to associate with the Master device and play the MPEG file (6 y Magic Hours) from Master device, the designated MPEG test file and instructions are located at:

<http://ntiacsd.ntia.doc.gov/dfs/>.

5.2 CALIBRATION OF DFS DETECTION THRESHOLD LEVEL:

The measured channel is 5510MHz. The radar signal was the same as transmitted channels, and injected into the antenna port of AP (master) or Client Device with Radar Detection, measured the channel closing transmission time and channel move time.

5.2.1 MASTER MODE

The Master antenna net gain is (-0.4)dBi and required detection threshold is -61.4dBm (= -62 +(-0.4) +1)dBm. The calibrated conducted detection threshold level is set to -61.4 dBm.

5.2.2 SLAVE WITHOUT RADAR DETECTION MODE

The Master antenna net gain is (-0.4)dBi and required detection threshold is -61.4dBm (= -62 +(-0.4) +1)dBm. The calibrated conducted detection threshold level is set to -61.4 dBm

Conducted setup configuration of Calibration of DFS Detection Threshold Level

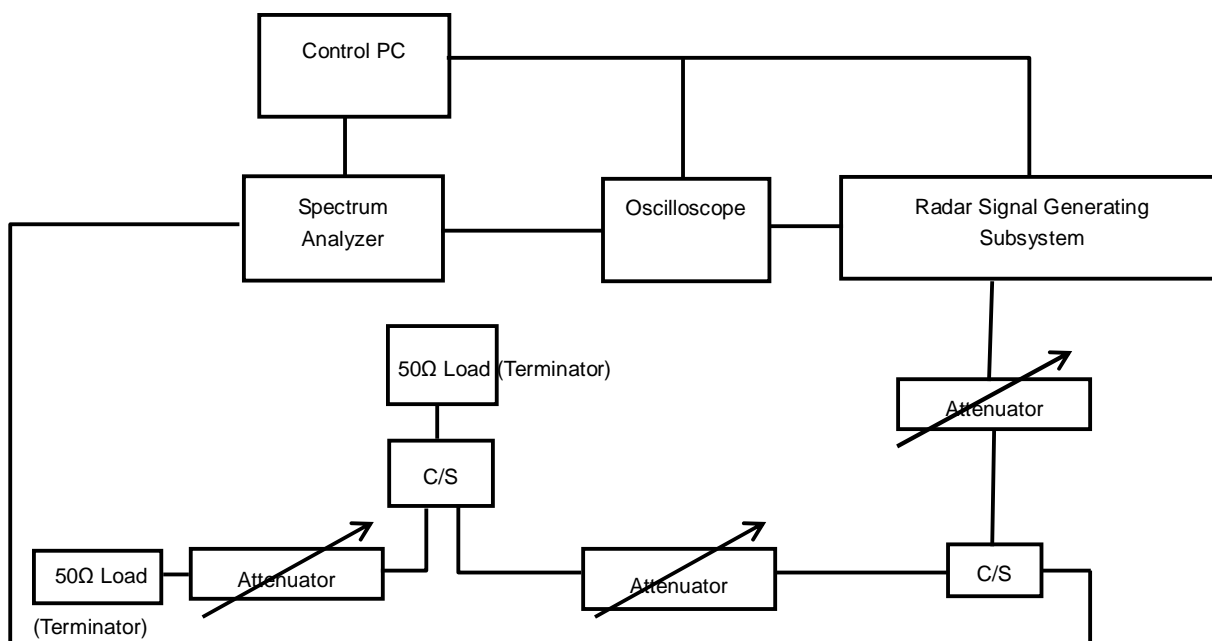

5.3 DEVIATION FROM TEST STANDARD

No deviation.

5.4 CONDUCTED TEST SETUP CONFIGURATION

5.4.1 MASTER MODE

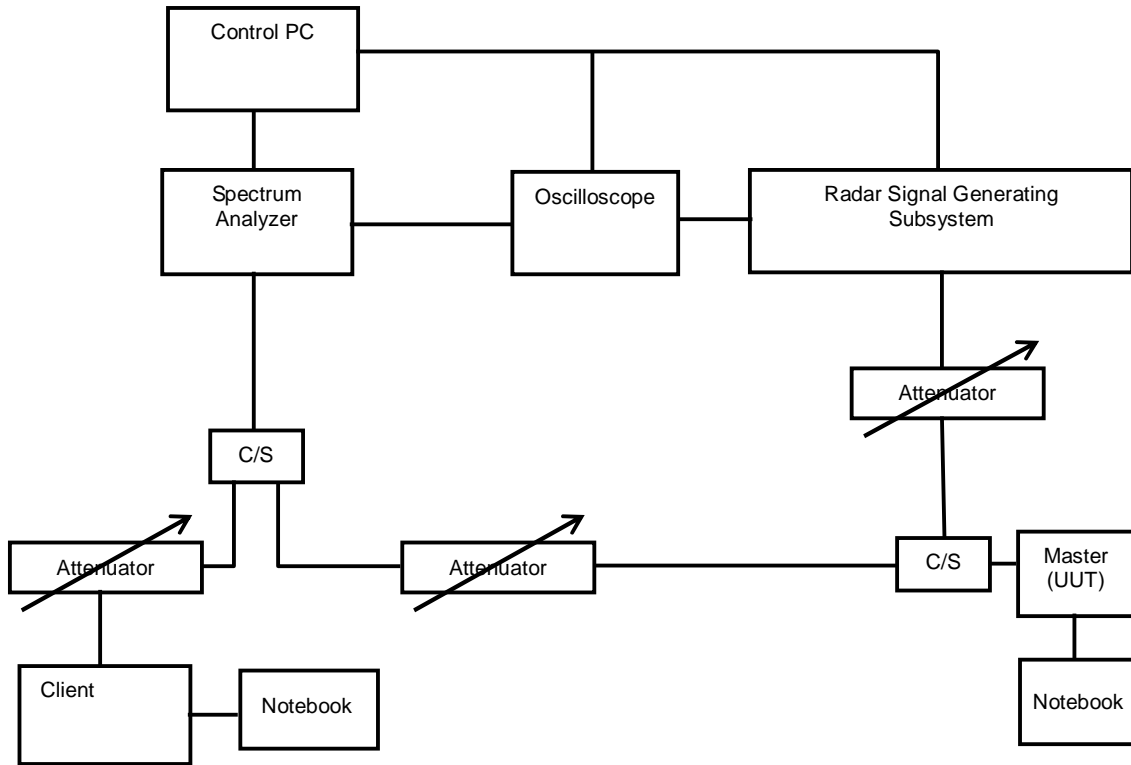

The UUT is a U-NII Device operating in Master mode. The radar test signals are injected into the Master Device.

5.4.2 SLAVE WITHOUT RADAR DETECTION MODE

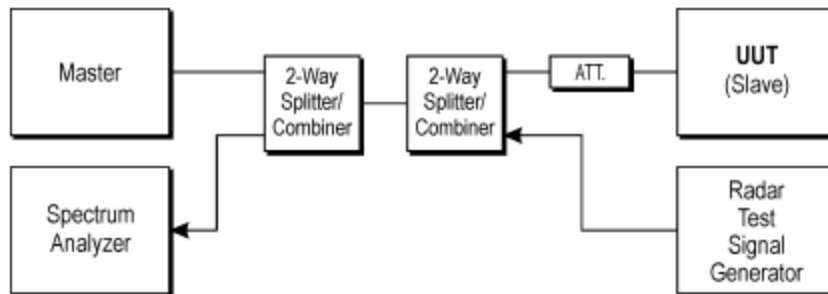

The UUT is a RLAN device operating in slave mode, without Radar Interference Detection function. The radar test signals are injected into the master device.



6. TEST RESULTS

6.1 SUMMARY OF TEST RESULT

6.1.1 MASTER MODE

Clause	Test Parameter	Remarks	Pass/Fail
15.407	DFS Detection Threshold	Applicable	Pass
15.407	Channel Availability Check Time	Applicable	Pass
15.407	Channel Move Time	Applicable	Pass
15.407	Channel Closing Transmission Time	Applicable	Pass
15.407	Non- Occupancy Period	Applicable	Pass
15.407	Uniform Spreading	Applicable	Pass
15.407	U-NII Detection Bandwidth	Applicable	Pass
15.407	Non-Co-Channel test	Applicable	Pass

6.1.2 SLAVE WITHOUT RADAR DETECTION MODE

CLAUSE	TEST PARAMETER	REMARKS	PASS/FAIL
15.407	DFS Detection Threshold	Not Applicable	NA
15.407	Channel Availability Check Time	Not Applicable	NA
15.407	Channel Move Time	Applicable	Pass
15.407	Channel Closing Transmission Time	Applicable	Pass
15.407	Non- Occupancy Period	Applicable	Pass
15.407	Uniform Spreading	Not Applicable	NA
15.407	U-NII Detection Bandwidth	Not Applicable	NA
15.407	Non-associated test	Applicable	Pass
15.407	Non-Co-Channel test	Applicable	Pass

6.2 DETAIL TEST RESULTS

6.2.1. TEST MODE: DEVICE OPERATING IN MASTER MODE.

6.2.1.1 DFS DETECTION THRESHOLD

For a detection threshold level of -61.4dBm and net gain is $(-0.4)\text{dBi}$. The required detection threshold is -61.4dBm ($= -62 + (-0.4)$) dBm . The conducted radar burst level is set to -62.4dBm .

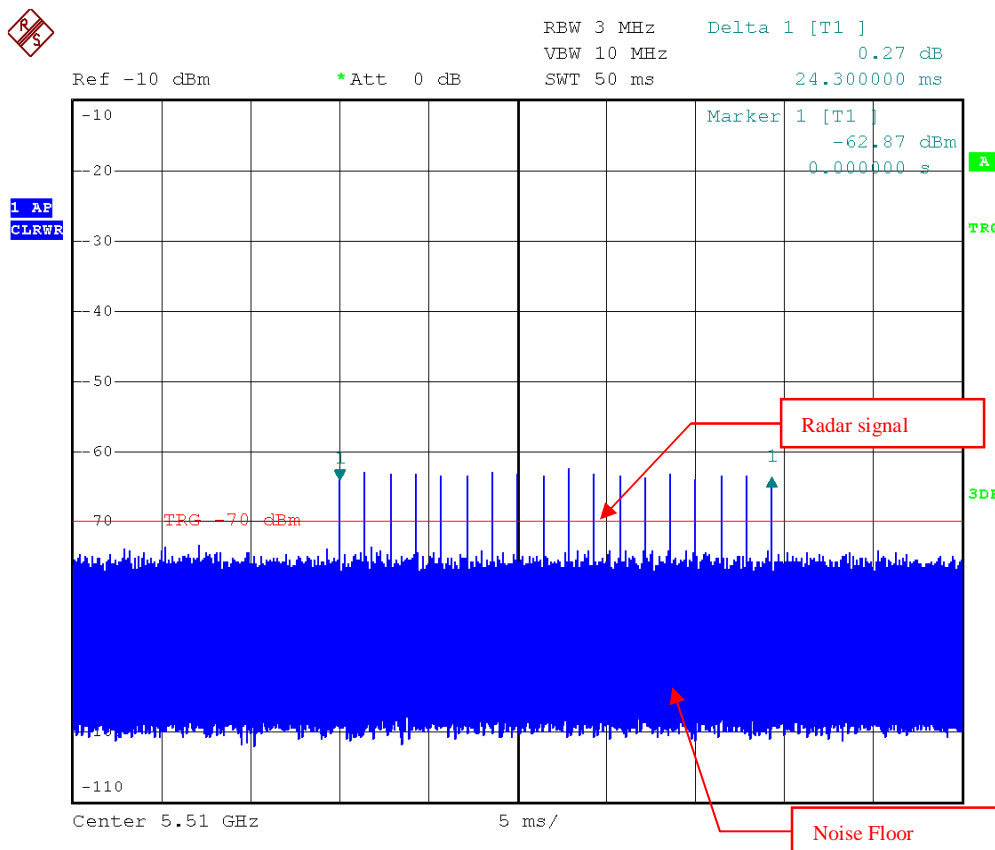

Radar Signal 1



A D T



REW 3 MHz Delta 1 [T1]
VBW 10 MHz -0.03 dB
SWT 10 ms 6.000000 ms

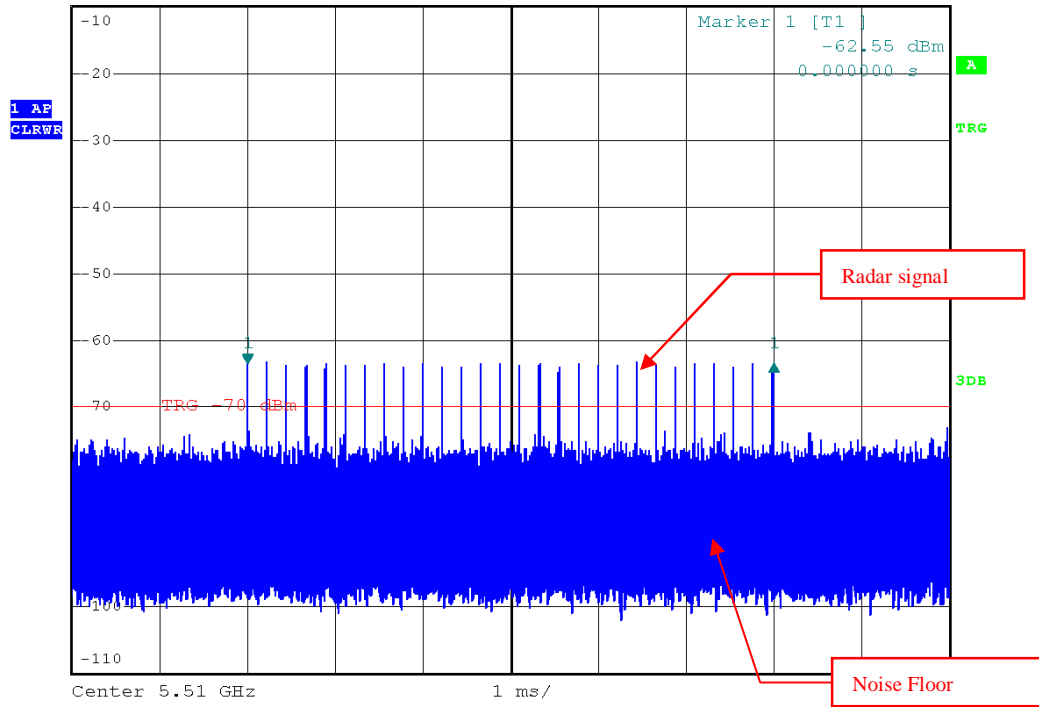

Radar Signal 2



A D T



REW 3 MHz Delta 1 [T1]
VBW 10 MHz 0.15 dB
SWT 10 ms 6.800000 ms

Ref -10 dBm *Att 0 dB

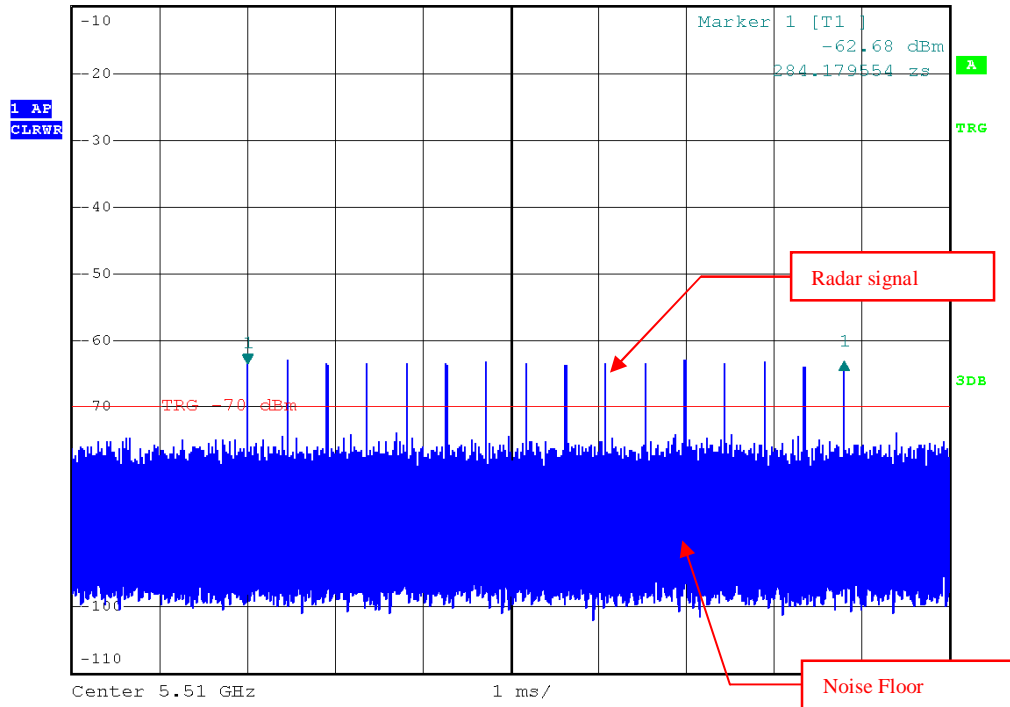

Radar Signal 3



A D T



Ref -10 dBm *Att 0 dB RBW 3 MHz Delta 1 [T1]
VBW 10 MHz -0.09 dB
SWT 10 ms 5.900000 ms

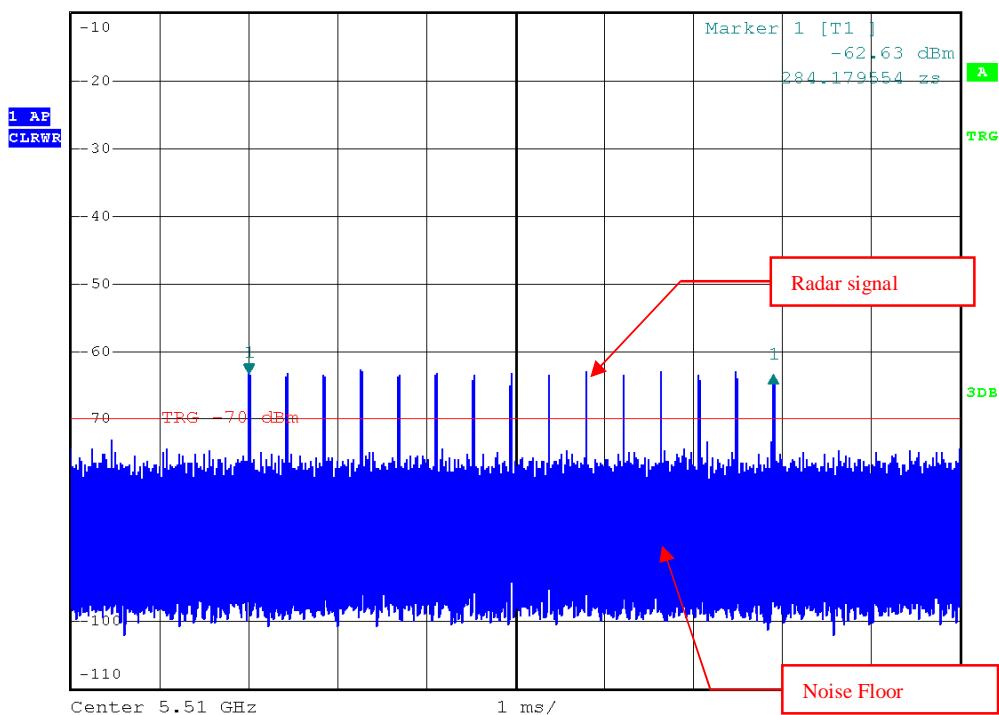

Radar Signal 4



A D T



Ref -10 dBm *Att 0 dB RBW 3 MHz Delta 1 [T1]
VBW 10 MHz -0.61 dB
SWT 20 s 11.245900 s

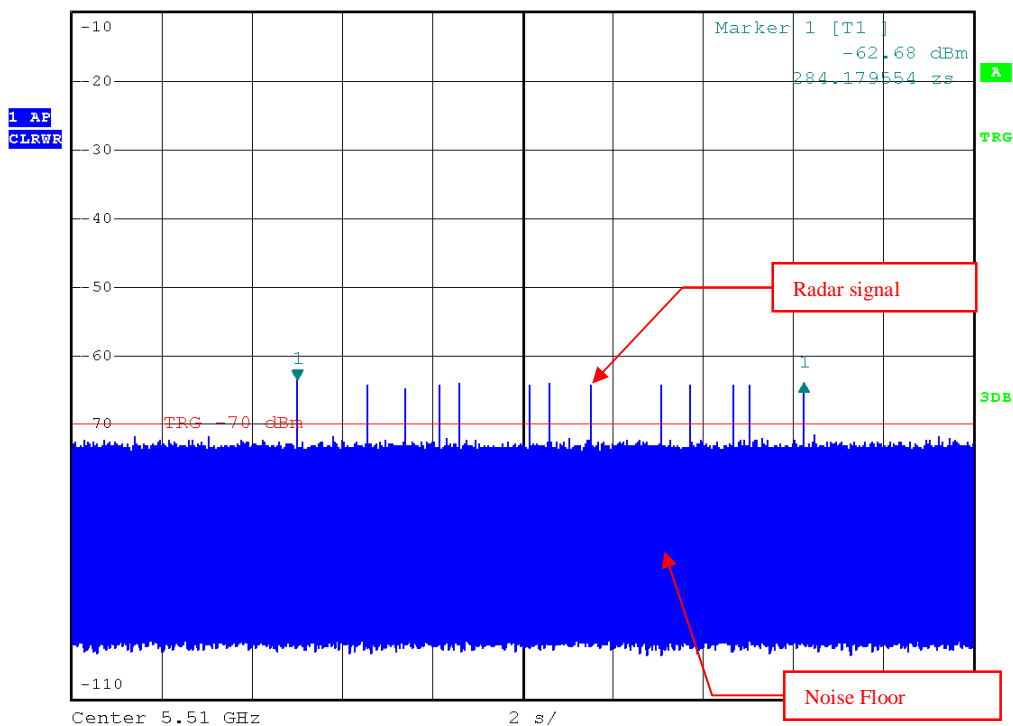

Radar Signal 5



A D T



REW 3 MHz Delta 1 [T1]
VBW 10 MHz -0.18 dB
SWT 10 ms 1.600000 ms

Ref -10 dBm *Att 0 dB

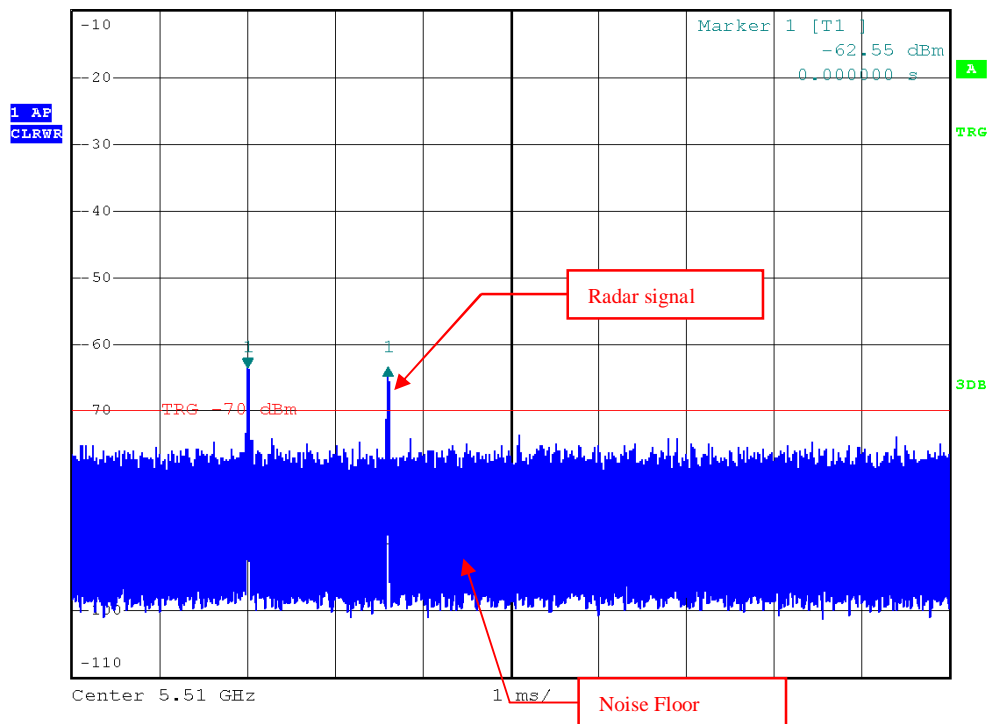

Single Burst of Radar Signal 5



A D T

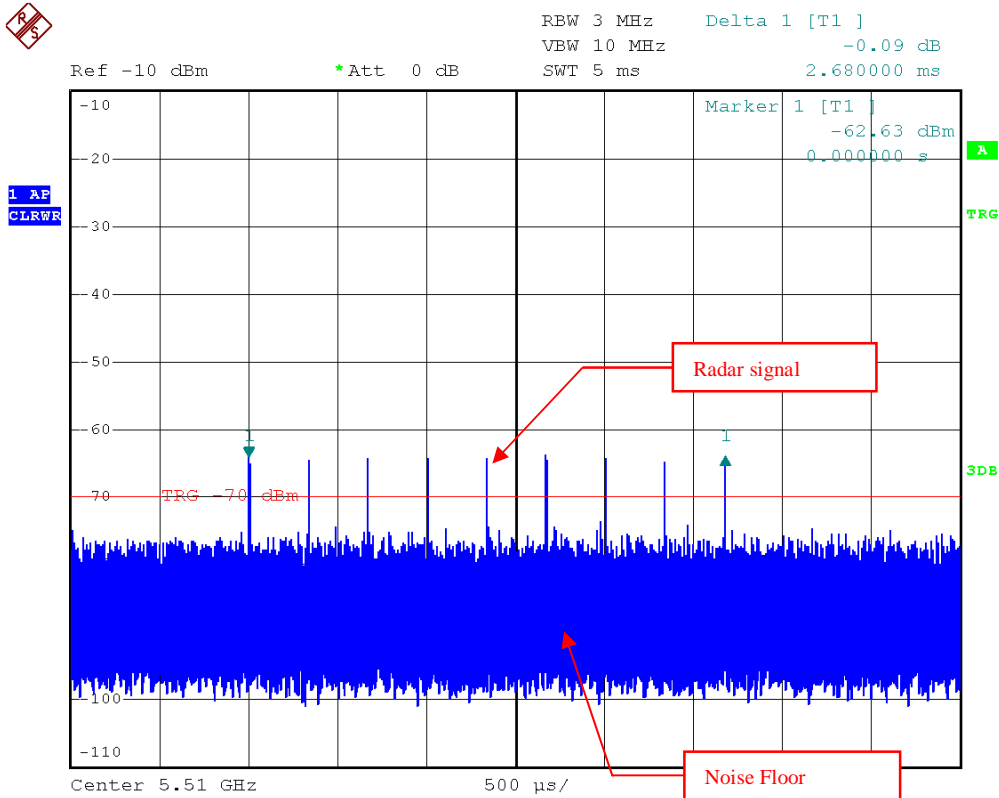

Radar Signal 6

6.2.1.2 CHANNEL AVAILABILITY CHECK TIME

Initial Channel Availability Check Time

Channel Availability Check @ CH100 - 5500MHz

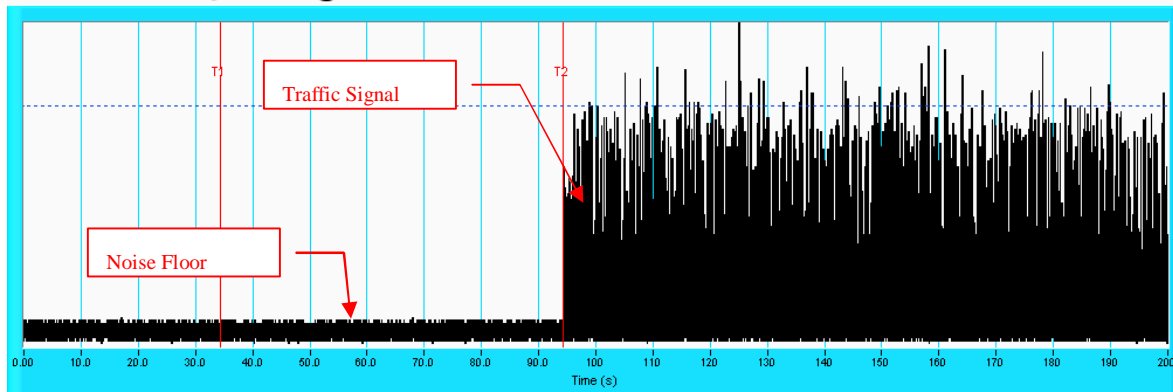

NOTE: T1 denotes the end of power-up time period is 34.4th second. T2 denotes the end of Channel Availability Check time is 94.4th second. Channel Availability Check time is equal to (T2 – T1) 60 seconds.

Radar Burst at the Beginning of the Channel Availability Check Time

Channel Availability Check @ CH100 - 5500MHz

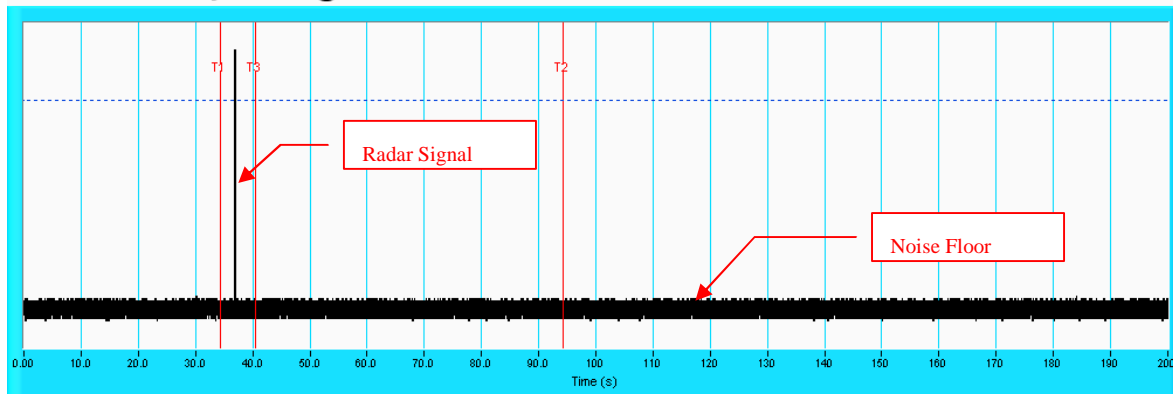

NOTE: T1 denotes the end of power up time period is 34.4th second. T3 denotes the radar burst was commenced within a 6 second window starting from the end of power-up sequence. T2 denotes the 94.4th second.

Radar Burst at the End of the Channel Availability Check Time Channel Availability Check @ CH100 - 5500MHz

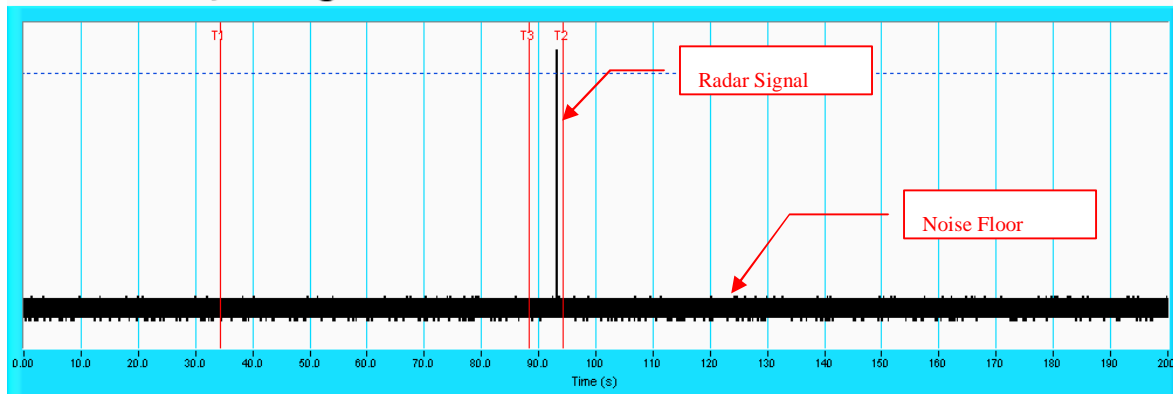

NOTE: T1 denotes the end of power up time period is 34.4th second. T2 denotes 94.4th second and T3 denotes the 88.4th second. The radar burst was commenced within 54th second to 60th second window starting from the end of power-up sequence.



6.2.1.3 CHANNEL CLOSING TRANSMISSION AND CHANNEL MOVE TIME 802.11n HT20

Table 4: Short Pulse Radar Test Waveforms.

Radar Type	Pulse Width (µsec)	PRI (µsec)	Number of Pulses	Number of Trials(Times)	Percentage of Successful Detection (%)
1	1	1428	18	30	96.7
2	1-5	150-230	23-29	30	93.3
3	6-10	200-500	16-18	30	90
4	11-20	200-500	12-16	30	86.7
Aggregate (Radar Types 1-4)				120	91.6

Table 5: Long Pulse Radar Test Waveform

Radar Type	Pulse Width (µsec)	Chirp Width (MHz)	PRI (µsec)	Number of Pulses per Burst	Number of Bursts	Number of Trials(Times)	Percentage of Successful Detection (%)
5	50-100	5-20	1000-2000	1-3	8-20	30	100

Table 6: Frequency Hopping Radar Test Waveform

Radar Type	Pulse Width (µsec)	PRI (µsec)	Pulses per Hop	Hopping Rate (kHz)	Hopping Sequence Length (msec)	Number of Trials(Times)	Percentage of Successful Detection (%)
6	1	333	9	0.333	300	30	96.7



802.11n HT40

Table 7: Short Pulse Radar Test Waveforms.

Radar Type	Pulse Width (µsec)	PRI (µsec)	Number of Pulses	Number of Trials(Times)	Percentage of Successful Detection (%)
1	1	1428	18	30	93.3
2	1-5	150-230	23-29	30	93.3
3	6-10	200-500	16-18	30	90
4	11-20	200-500	12-16	30	86.7
Aggregate (Radar Types 1-4)				120	90.8

Table 8: Long Pulse Radar Test Waveform

Radar Type	Pulse Width (µsec)	Chirp Width (MHz)	PRI (µsec)	Number of Pulses per Burst	Number of Bursts	Number of Trials(Times)	Percentage of Successful Detection (%)
5	50-100	5-20	1000-2000	1-3	8-20	30	100

Table 9: Frequency Hopping Radar Test Waveform

Radar Type	Pulse Width (µsec)	PRI (µsec)	Pulses per Hop	Hopping Rate (kHz)	Hopping Sequence Length (msec)	Number of Trials(Times)	Percentage of Successful Detection (%)
6	1	333	9	0.333	300	30	100



A D T

WLAN TRAFFIC

802.11n HT40

Duty Cycle @ CH102 - 5510MHz

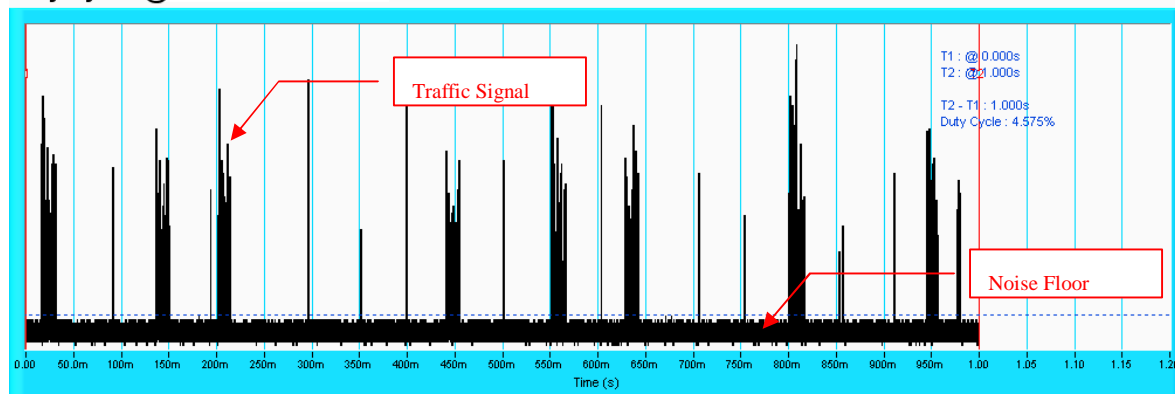

NOTE: T1 denotes the start of duty cycle period is 0th second. T2 denotes the end of duty cycle period is 1th second. T2 – T1= 1 seconds. Duty Cycle = 4.575%

Radar signal 1

Channel Closing Transmission Time & Channel Move Time @ CH102 - 5510MHz

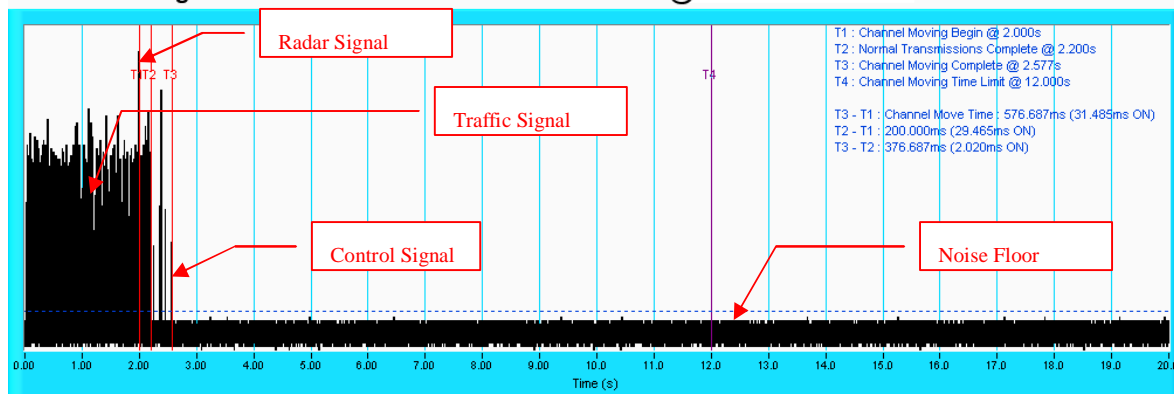

NOTE: T1 denotes the start of Channel Move Time upon the end of the last Radar burst. T2 denotes the data transmission time of 200ms from T1. T3 denotes the end of Channel Move Time. T4 denotes the 10 second from T1 to observe the aggregate duration of transmissions.

Channel Closing Transmission Time & Channel Move Time @ CH102 - 5510MHz

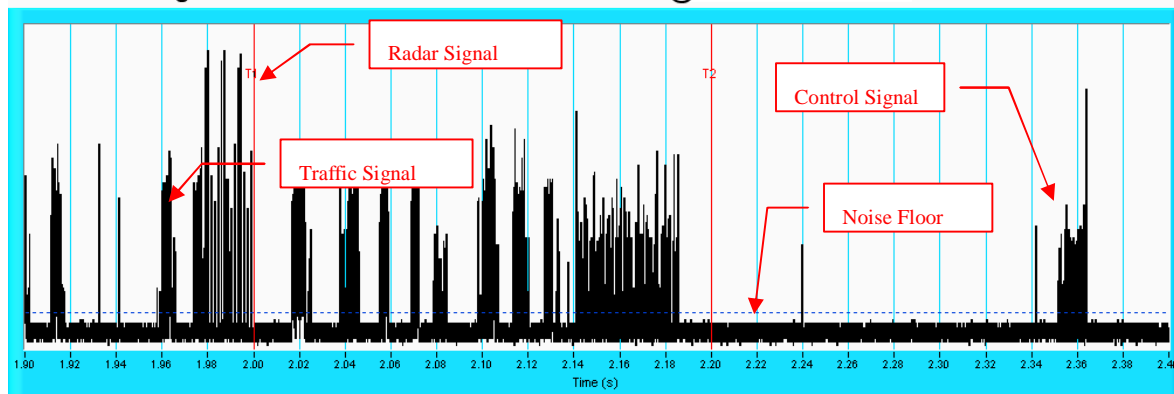

NOTE: An expanded plot for the device vacates the channel in the required 500ms.

Radar signal 2

Channel Closing Transmission Time & Channel Move Time @ CH102 - 5510MHz

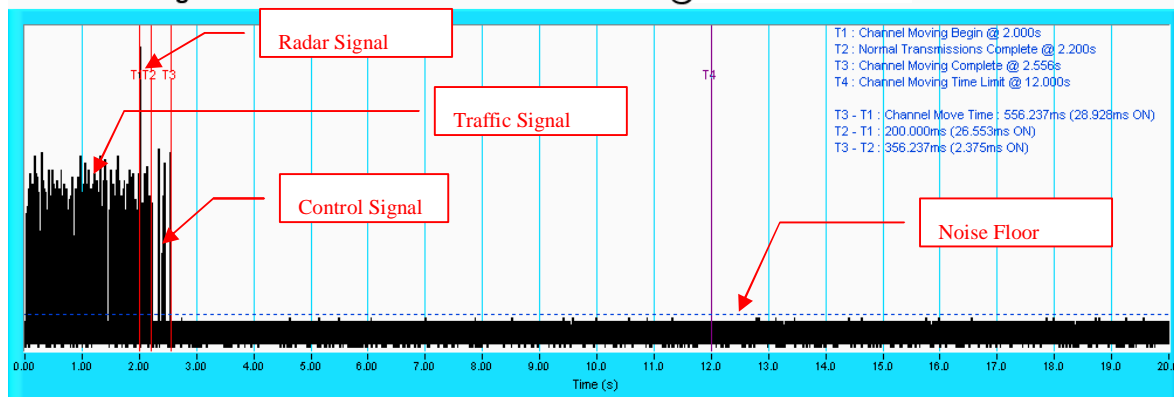

NOTE: T1 denotes the start of Channel Move Time upon the end of the last Radar burst. T2 denotes the data transmission time of 200ms from T1. T3 denotes the end of Channel Move Time. T4 denotes the 10 second from T1 to observe the aggregate duration of transmissions.

Channel Closing Transmission Time & Channel Move Time @ CH102 - 5510MHz

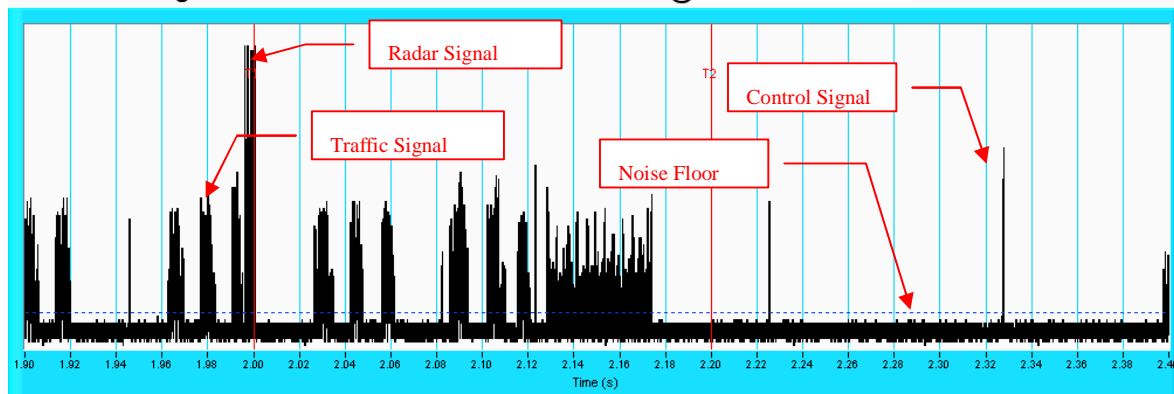

NOTE: An expanded plot for the device vacates the channel in the required 500ms.

Radar signal 3

Channel Closing Transmission Time & Channel Move Time @ CH102 - 5510MHz

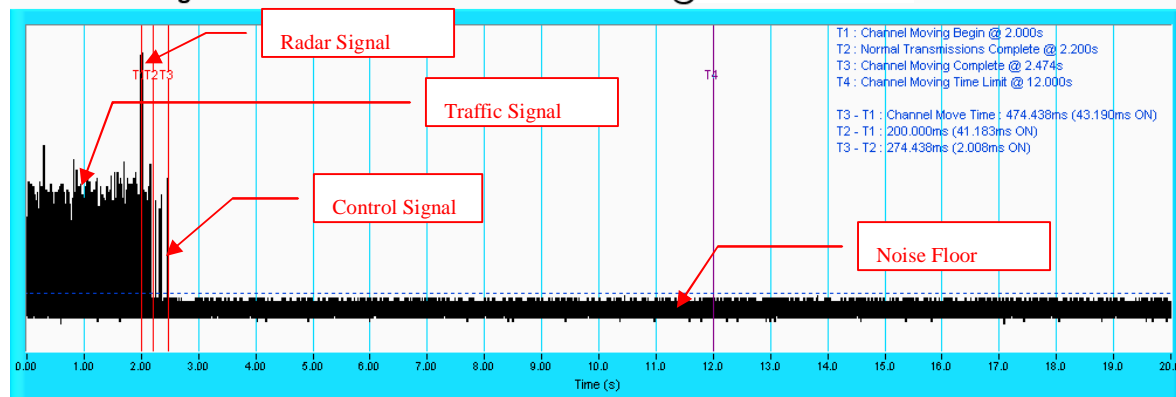

NOTE: T1 denotes the start of Channel Move Time upon the end of the last Radar burst. T2 denotes the data transmission time of 200ms from T1. T3 denotes the end of Channel Move Time. T4 denotes the 10 second from T1 to observe the aggregate duration of transmissions.

Channel Closing Transmission Time & Channel Move Time @ CH102 - 5510MHz

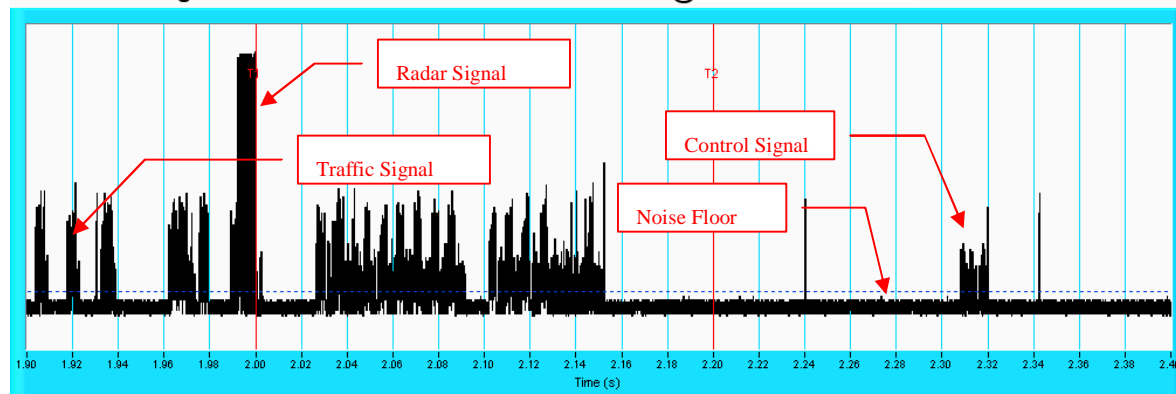

NOTE: An expanded plot for the device vacates the channel in the required 500ms.

Radar signal 4

Channel Closing Transmission Time & Channel Move Time @ CH102 - 5510MHz

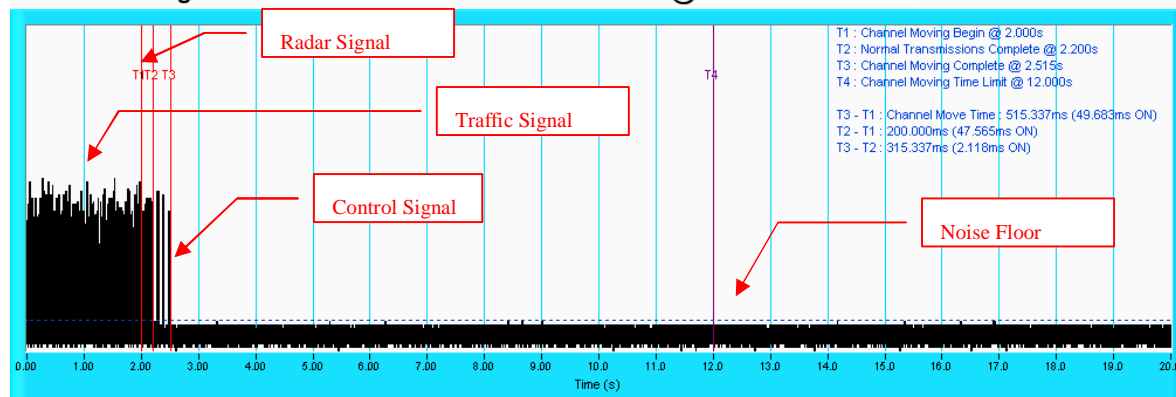

NOTE: T1 denotes the start of Channel Move Time upon the end of the last Radar burst. T2 denotes the data transmission time of 200ms from T1. T3 denotes the end of Channel Move Time. T4 denotes the 10 second from T1 to observe the aggregate duration of transmissions.

Channel Closing Transmission Time & Channel Move Time @ CH102 - 5510MHz

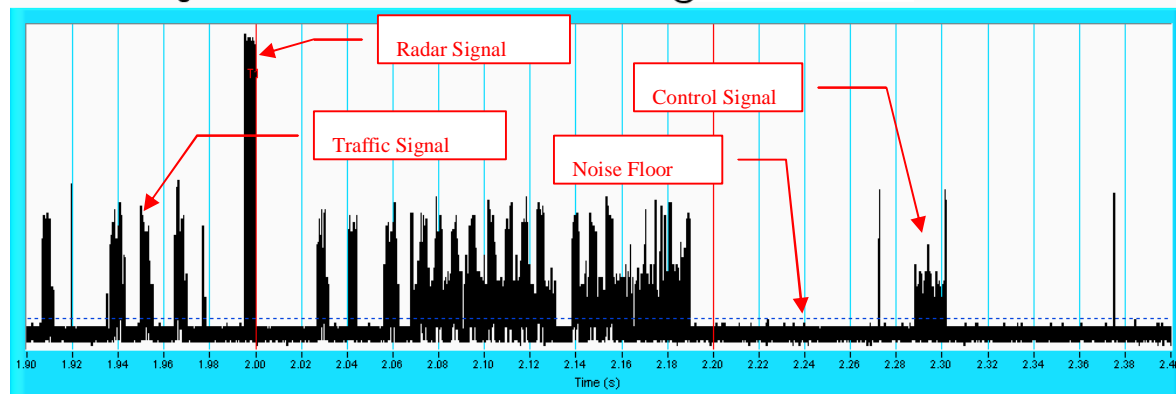

NOTE: An expanded plot for the device vacates the channel in the required 500ms.

Radar signal 5

Channel Closing Transmission Time & Channel Move Time @ CH102 - 5510MHz

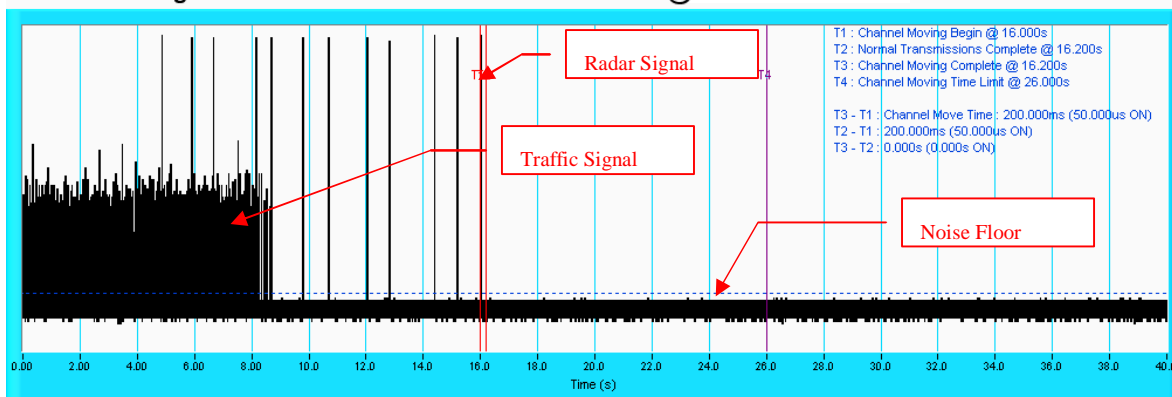

NOTE: T1 denotes the start of Channel Move Time upon the end of the last Radar burst. T2 denotes the data transmission time of 200ms from T1. T3 denotes the end of Channel Move Time. T4 denotes the 10 second from T1 to observe the aggregate duration of transmissions.

Channel Closing Transmission Time & Channel Move Time @ CH102 - 5510MHz

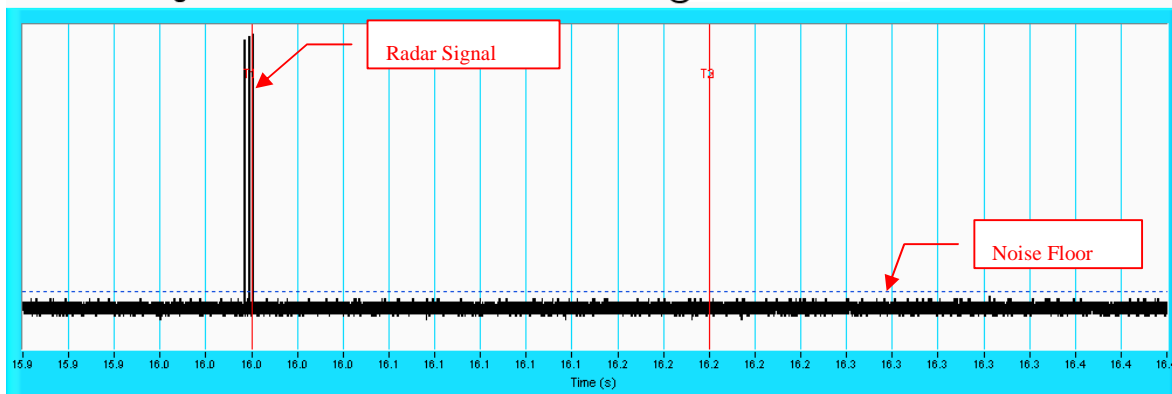

NOTE: An expanded plot for the device vacates the channel in the required 500ms.

Radar signal 6

Channel Closing Transmission Time & Channel Move Time @ CH102 - 5510MHz

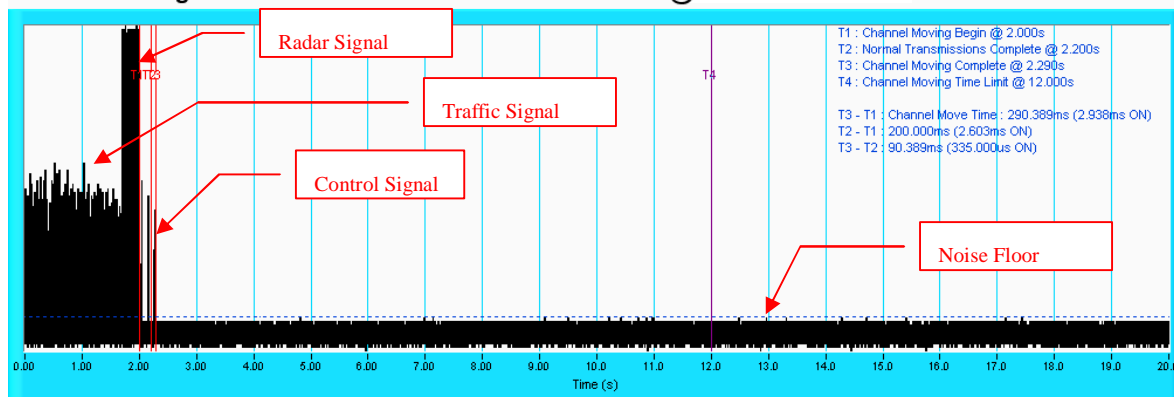

NOTE: T1 denotes the start of Channel Move Time upon the end of the last Radar burst. T2 denotes the data transmission time of 200ms from T1. T3 denotes the end of Channel Move Time. T4 denotes the 10 second from T1 to observe the aggregate duration of transmissions.

Channel Closing Transmission Time & Channel Move Time @ CH102 - 5510MHz

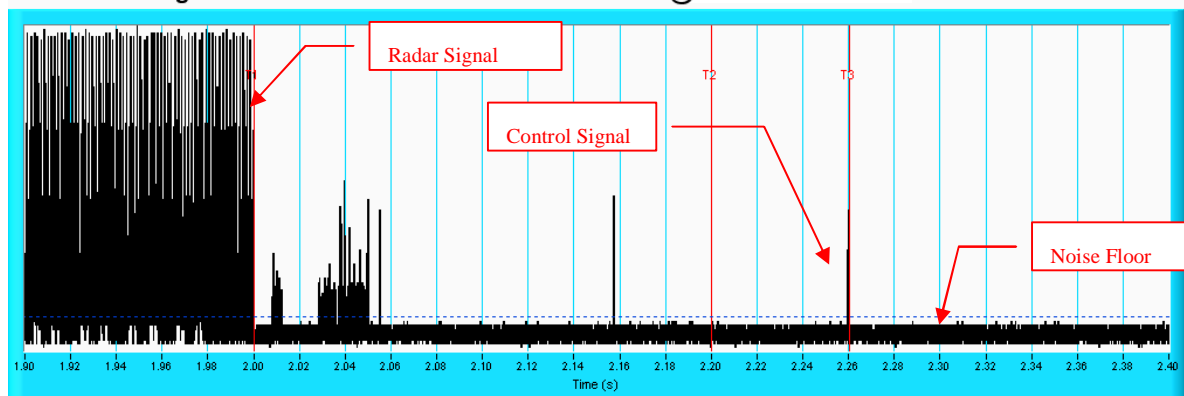

NOTE: An expanded plot for the device vacates the channel in the required 500ms.



A D T

802.11n HT20

Type 1 Radar Statistical Performances				
Trial #	Pulses per Burst	Pulse Width (s)	PRI (s)	Detection
1	18	1.0u	1.428m	Yes
2	18	1.0u	1.428m	Yes
3	18	1.0u	1.428m	Yes
4	18	1.0u	1.428m	Yes
5	18	1.0u	1.428m	Yes
6	18	1.0u	1.428m	Yes
7	18	1.0u	1.428m	Yes
8	18	1.0u	1.428m	Yes
9	18	1.0u	1.428m	Yes
10	18	1.0u	1.428m	Yes
11	18	1.0u	1.428m	No
12	18	1.0u	1.428m	Yes
13	18	1.0u	1.428m	Yes
14	18	1.0u	1.428m	Yes
15	18	1.0u	1.428m	Yes
16	18	1.0u	1.428m	Yes
17	18	1.0u	1.428m	Yes
18	18	1.0u	1.428m	Yes
19	18	1.0u	1.428m	Yes
20	18	1.0u	1.428m	Yes
21	18	1.0u	1.428m	Yes
22	18	1.0u	1.428m	Yes
23	18	1.0u	1.428m	Yes
24	18	1.0u	1.428m	Yes
25	18	1.0u	1.428m	Yes
26	18	1.0u	1.428m	Yes
27	18	1.0u	1.428m	Yes
28	18	1.0u	1.428m	Yes
29	18	1.0u	1.428m	Yes
30	18	1.0u	1.428m	Yes
				Detection Rate: 96.7 %



A D T

802.11n HT20

Type 2 Radar Statistical Performances				
Trial #	Pulses per Burst	Pulse Width (s)	PRI (s)	Detection
1	28	2.5u	179.0u	Yes
2	26	1.3u	177.0u	No
3	23	3.4u	198.0u	Yes
4	28	2.8u	166.0u	Yes
5	23	3.6u	210.0u	Yes
6	26	4.4u	223.0u	Yes
7	24	2.5u	222.0u	Yes
8	23	1.9u	194.0u	Yes
9	26	3.2u	159.0u	Yes
10	27	3.6u	211.0u	Yes
11	25	1.0u	158.0u	Yes
12	27	3.9u	222.0u	Yes
13	25	1.1u	160.0u	Yes
14	27	3.5u	198.0u	Yes
15	24	2.2u	194.0u	Yes
16	24	1.8u	181.0u	Yes
17	27	4.6u	208.0u	Yes
18	25	3.8u	189.0u	Yes
19	23	3.3u	200.0u	Yes
20	25	4.9u	151.0u	Yes
21	28	1.9u	182.0u	No
22	27	4.6u	222.0u	Yes
23	28	1.3u	224.0u	Yes
24	26	2.5u	205.0u	Yes
25	25	3.1u	222.0u	Yes
26	24	1.1u	224.0u	Yes
27	24	3.5u	189.0u	Yes
28	26	1.9u	151.0u	Yes
29	28	1.4u	210.0u	Yes
30	28	1.2u	212.0u	Yes
				Detection Rate: 93.3 %



A D T

802.11n HT20

Type 3 Radar Statistical Performances				
Trial #	Pulses per Burst	Pulse Width (s)	PRI (s)	Detection
1	16	9.9u	332.0u	Yes
2	16	9.3u	464.0u	No
3	16	7.4u	492.0u	Yes
4	17	9.2u	260.0u	Yes
5	17	9.1u	318.0u	Yes
6	17	8.4u	368.0u	Yes
7	18	8.6u	319.0u	Yes
8	17	8.9u	361.0u	Yes
9	17	6.7u	341.0u	Yes
10	18	9.9u	441.0u	Yes
11	18	6.2u	322.0u	Yes
12	16	9.8u	350.0u	Yes
13	17	8.0u	284.0u	Yes
14	17	7.6u	302.0u	Yes
15	16	8.0u	358.0u	Yes
16	16	6.7u	228.0u	No
17	18	6.5u	238.0u	Yes
18	17	9.9u	494.0u	No
19	18	6.0u	200.0u	Yes
20	18	6.8u	409.0u	Yes
21	16	9.9u	303.0u	Yes
22	16	8.2u	330.0u	Yes
23	18	7.6u	415.0u	Yes
24	18	8.9u	291.0u	Yes
25	17	9.5u	262.0u	Yes
26	18	8.0u	234.0u	Yes
27	17	9.1u	320.0u	Yes
28	17	8.6u	392.0u	Yes
29	18	6.3u	322.0u	Yes
30	17	6.9u	414.0u	Yes
				Detection Rate: 90 %



A D T

802.11n HT20

Type 4 Radar Statistical Performances				
Trial #	Pulses per Burst	Pulse Width (s)	PRI (s)	Detection
1	15	13.3u	447.0u	Yes
2	14	13.0u	470.0u	No
3	14	15.1u	305.0u	Yes
4	14	14.7u	334.0u	Yes
5	13	17.6u	332.0u	No
6	15	16.3u	364.0u	Yes
7	14	19.2u	354.0u	Yes
8	12	16.5u	248.0u	Yes
9	12	15.0u	419.0u	Yes
10	13	17.6u	281.0u	No
11	14	17.9u	425.0u	Yes
12	13	17.1u	244.0u	Yes
13	13	13.8u	305.0u	Yes
14	13	14.8u	391.0u	Yes
15	16	19.0u	460.0u	Yes
16	16	12.9u	275.0u	Yes
17	14	11.2u	237.0u	Yes
18	15	12.3u	369.0u	Yes
19	15	14.1u	264.0u	Yes
20	13	19.7u	304.0u	Yes
21	14	18.5u	345.0u	Yes
22	16	17.6u	339.0u	Yes
23	14	18.4u	296.0u	Yes
24	13	14.0u	459.0u	Yes
25	13	15.1u	330.0u	No
26	14	17.8u	443.0u	Yes
27	13	15.9u	230.0u	Yes
28	14	16.1u	291.0u	Yes
29	15	17.4u	348.0u	Yes
30	15	11.2u	432.0u	Yes
				Detection Rate: 86.7 %



A D T

802.11n HT20

Type 5 Radar Statistical Performances

Trial #	Test Signal Name	Detection
1	LP_HT20_Signal_01	Yes
2	LP_HT20_Signal_02	Yes
3	LP_HT20_Signal_03	Yes
4	LP_HT20_Signal_04	Yes
5	LP_HT20_Signal_05	Yes
6	LP_HT20_Signal_06	Yes
7	LP_HT20_Signal_07	Yes
8	LP_HT20_Signal_08	Yes
9	LP_HT20_Signal_09	Yes
10	LP_HT20_Signal_10	Yes
11	LP_HT20_Signal_11	Yes
12	LP_HT20_Signal_12	Yes
13	LP_HT20_Signal_13	Yes
14	LP_HT20_Signal_14	Yes
15	LP_HT20_Signal_15	Yes
16	LP_HT20_Signal_16	Yes
17	LP_HT20_Signal_17	Yes
18	LP_HT20_Signal_18	Yes
19	LP_HT20_Signal_19	Yes
20	LP_HT20_Signal_20	Yes
21	LP_HT20_Signal_21	Yes
22	LP_HT20_Signal_22	Yes
23	LP_HT20_Signal_23	Yes
24	LP_HT20_Signal_24	Yes
25	LP_HT20_Signal_25	Yes
26	LP_HT20_Signal_26	Yes
27	LP_HT20_Signal_27	Yes
28	LP_HT20_Signal_28	Yes
29	LP_HT20_Signal_29	Yes
30	LP_HT20_Signal_30	Yes
		Detection Rate: 100.0 %

The Long Pulse Radar pattern shown in Annex B.1



A D T

802.11n HT20

Type 6 Radar Statistical Performances

Trial #	Pulses per Burst	Pulse Width (s)	PRI (s)	Detection
1	9	1.0u	333.0u	Yes
2	9	1.0u	333.0u	Yes
3	9	1.0u	333.0u	Yes
4	9	1.0u	333.0u	Yes
5	9	1.0u	333.0u	Yes
6	9	1.0u	333.0u	Yes
7	9	1.0u	333.0u	Yes
8	9	1.0u	333.0u	Yes
9	9	1.0u	333.0u	Yes
10	9	1.0u	333.0u	Yes
11	9	1.0u	333.0u	Yes
12	9	1.0u	333.0u	Yes
13	9	1.0u	333.0u	Yes
14	9	1.0u	333.0u	Yes
15	9	1.0u	333.0u	Yes
16	9	1.0u	333.0u	Yes
17	9	1.0u	333.0u	Yes
18	9	1.0u	333.0u	Yes
19	9	1.0u	333.0u	Yes
20	9	1.0u	333.0u	Yes
21	9	1.0u	333.0u	Yes
22	9	1.0u	333.0u	Yes
23	9	1.0u	333.0u	Yes
24	9	1.0u	333.0u	Yes
25	9	1.0u	333.0u	Yes
26	9	1.0u	333.0u	Yes
27	9	1.0u	333.0u	Yes
28	9	1.0u	333.0u	Yes
29	9	1.0u	333.0u	Yes
30	9	1.0u	333.0u	Yes
				Detection Rate: 100.0 %



A D T

802.11n HT20

Type 6 Radar Statistical Performances		
Trial #	Hopping Frequency Sequence Name	Detection
1	HOP_FREQ_SEQ_HT20_01	Yes
2	HOP_FREQ_SEQ_HT20_02	Yes
3	HOP_FREQ_SEQ_HT20_03	Yes
4	HOP_FREQ_SEQ_HT20_04	Yes
5	HOP_FREQ_SEQ_HT20_05	Yes
6	HOP_FREQ_SEQ_HT20_06	Yes
7	HOP_FREQ_SEQ_HT20_07	Yes
8	HOP_FREQ_SEQ_HT20_08	Yes
9	HOP_FREQ_SEQ_HT20_09	Yes
10	HOP_FREQ_SEQ_HT20_10	Yes
11	HOP_FREQ_SEQ_HT20_11	Yes
12	HOP_FREQ_SEQ_HT20_12	Yes
13	HOP_FREQ_SEQ_HT20_13	No
14	HOP_FREQ_SEQ_HT20_14	Yes
15	HOP_FREQ_SEQ_HT20_15	Yes
16	HOP_FREQ_SEQ_HT20_16	Yes
17	HOP_FREQ_SEQ_HT20_17	Yes
18	HOP_FREQ_SEQ_HT20_18	Yes
19	HOP_FREQ_SEQ_HT20_19	Yes
20	HOP_FREQ_SEQ_HT20_20	Yes
21	HOP_FREQ_SEQ_HT20_21	Yes
22	HOP_FREQ_SEQ_HT20_22	Yes
23	HOP_FREQ_SEQ_HT20_23	Yes
24	HOP_FREQ_SEQ_HT20_24	Yes
25	HOP_FREQ_SEQ_HT20_25	Yes
26	HOP_FREQ_SEQ_HT20_26	Yes
27	HOP_FREQ_SEQ_HT20_27	Yes
28	HOP_FREQ_SEQ_HT20_28	Yes
29	HOP_FREQ_SEQ_HT20_29	Yes
30	HOP_FREQ_SEQ_HT20_30	Yes
		Detection Rate: 96.7 %

The Frequency Hopping Radar pattern shown in Annex B.2



A D T

802.11n HT40

Type 1 Radar Statistical Performances

Trial #	Pulses per Burst	Pulse Width (s)	PRI (s)	Detection
1	18	1.0u	1.428m	Yes
2	18	1.0u	1.428m	Yes
3	18	1.0u	1.428m	Yes
4	18	1.0u	1.428m	Yes
5	18	1.0u	1.428m	Yes
6	18	1.0u	1.428m	Yes
7	18	1.0u	1.428m	Yes
8	18	1.0u	1.428m	No
9	18	1.0u	1.428m	Yes
10	18	1.0u	1.428m	Yes
11	18	1.0u	1.428m	Yes
12	18	1.0u	1.428m	Yes
13	18	1.0u	1.428m	Yes
14	18	1.0u	1.428m	No
15	18	1.0u	1.428m	Yes
16	18	1.0u	1.428m	Yes
17	18	1.0u	1.428m	Yes
18	18	1.0u	1.428m	Yes
19	18	1.0u	1.428m	Yes
20	18	1.0u	1.428m	Yes
21	18	1.0u	1.428m	Yes
22	18	1.0u	1.428m	Yes
23	18	1.0u	1.428m	Yes
24	18	1.0u	1.428m	Yes
25	18	1.0u	1.428m	Yes
26	18	1.0u	1.428m	Yes
27	18	1.0u	1.428m	Yes
28	18	1.0u	1.428m	Yes
29	18	1.0u	1.428m	Yes
30	18	1.0u	1.428m	Yes

Detection Rate: 93.3%



A D T

802.11n HT40

Type 2 Radar Statistical Performances				
Trial #	Pulses per Burst	Pulse Width (s)	PRI (s)	Detection
1	29	5.0u	155.0u	Yes
2	24	4.0u	175.0u	Yes
3	28	5.0u	207.0u	Yes
4	25	3.8u	212.0u	Yes
5	25	3.2u	151.0u	Yes
6	29	4.0u	201.0u	Yes
7	23	2.5u	223.0u	Yes
8	24	4.3u	161.0u	Yes
9	24	3.5u	183.0u	Yes
10	23	4.9u	165.0u	Yes
11	27	2.3u	207.0u	Yes
12	24	1.6u	223.0u	Yes
13	26	4.2u	212.0u	Yes
14	25	4.3u	219.0u	Yes
15	27	3.1u	194.0u	Yes
16	27	1.3u	171.0u	No
17	25	2.2u	165.0u	Yes
18	28	1.4u	214.0u	Yes
19	28	4.2u	194.0u	Yes
20	27	4.2u	195.0u	Yes
21	27	1.3u	200.0u	Yes
22	28	2.0u	229.0u	Yes
23	28	4.2u	224.0u	Yes
24	25	3.2u	222.0u	Yes
25	28	4.7u	182.0u	No
26	27	4.6u	202.0u	Yes
27	25	3.5u	200.0u	Yes
28	28	1.7u	210.0u	Yes
29	27	1.3u	205.0u	Yes
30	25	4.5u	160.0u	Yes
				Detection Rate: 93.3 %



A D T

802.11n HT40

Type 3 Radar Statistical Performances				
Trial #	Pulses per Burst	Pulse Width (s)	PRI (s)	Detection
1	16	9.5u	474.0u	Yes
2	17	8.2u	269.0u	Yes
3	17	7.5u	247.0u	Yes
4	17	6.2u	294.0u	Yes
5	16	7.3u	495.0u	Yes
6	18	6.1u	237.0u	Yes
7	18	7.4u	419.0u	No
8	17	8.0u	257.0u	Yes
9	17	7.5u	392.0u	Yes
10	17	9.6u	308.0u	Yes
11	18	7.3u	262.0u	Yes
12	16	7.7u	231.0u	Yes
13	17	8.1u	390.0u	Yes
14	16	7.6u	370.0u	Yes
15	17	6.8u	397.0u	Yes
16	16	8.6u	271.0u	Yes
17	16	6.7u	375.0u	Yes
18	18	6.3u	407.0u	Yes
19	18	7.4u	386.0u	Yes
20	17	7.4u	339.0u	Yes
21	17	6.6u	480.0u	Yes
22	17	9.8u	477.0u	Yes
23	17	9.2u	455.0u	Yes
24	17	9.9u	332.0u	Yes
25	17	8.6u	462.0u	No
26	17	6.3u	438.0u	Yes
27	18	7.2u	314.0u	No
28	17	7.3u	464.0u	Yes
29	18	6.6u	390.0u	Yes
30	18	9.7u	448.0u	Yes
				Detection Rate: 90.0 %



A D T

802.11n HT40

Type 4 Radar Statistical Performances				
Trial #	Pulses per Burst	Pulse Width (s)	PRI (s)	Detection
1	13	18.0u	451.0u	Yes
2	13	18.0u	264.0u	Yes
3	13	18.5u	387.0u	Yes
4	14	13.6u	232.0u	Yes
5	15	19.5u	421.0u	No
6	13	13.4u	355.0u	Yes
7	14	17.1u	498.0u	Yes
8	12	14.1u	469.0u	No
9	13	17.9u	309.0u	Yes
10	13	14.6u	383.0u	No
11	16	15.0u	417.0u	Yes
12	15	11.1u	483.0u	Yes
13	13	19.8u	355.0u	Yes
14	14	15.3u	262.0u	Yes
15	13	16.8u	494.0u	No
16	13	11.5u	484.0u	Yes
17	15	13.9u	262.0u	Yes
18	13	11.3u	393.0u	Yes
19	13	11.4u	419.0u	Yes
20	14	14.8u	344.0u	Yes
21	14	15.9u	228.0u	Yes
22	15	12.9u	361.0u	Yes
23	13	12.0u	230.0u	Yes
24	15	16.2u	449.0u	Yes
25	14	16.1u	490.0u	Yes
26	14	12.7u	202.0u	Yes
27	15	16.3u	243.0u	Yes
28	15	11.0u	377.0u	Yes
29	15	12.4u	464.0u	Yes
30	13	14.5u	340.0u	Yes
				Detection Rate: 86.7 %



A D T

802.11n HT40

Type 5 Radar Statistical Performances

Trial #	Test Signal Name	Detection
1	LP_HT40_Signal_01	Yes
2	LP_HT40_Signal_02	Yes
3	LP_HT40_Signal_03	Yes
4	LP_HT40_Signal_04	Yes
5	LP_HT40_Signal_05	Yes
6	LP_HT40_Signal_06	Yes
7	LP_HT40_Signal_07	Yes
8	LP_HT40_Signal_08	Yes
9	LP_HT40_Signal_09	Yes
10	LP_HT40_Signal_10	Yes
11	LP_HT40_Signal_11	Yes
12	LP_HT40_Signal_12	Yes
13	LP_HT40_Signal_13	Yes
14	LP_HT40_Signal_14	Yes
15	LP_HT40_Signal_15	Yes
16	LP_HT40_Signal_16	Yes
17	LP_HT40_Signal_17	Yes
18	LP_HT40_Signal_18	Yes
19	LP_HT40_Signal_19	Yes
20	LP_HT40_Signal_20	Yes
21	LP_HT40_Signal_21	Yes
22	LP_HT40_Signal_22	Yes
23	LP_HT40_Signal_23	Yes
24	LP_HT40_Signal_24	Yes
25	LP_HT40_Signal_25	Yes
26	LP_HT40_Signal_26	Yes
27	LP_HT40_Signal_27	Yes
28	LP_HT40_Signal_28	Yes
29	LP_HT40_Signal_29	Yes
30	LP_HT40_Signal_30	Yes
		Detection Rate: 100 %

The Long Pulse Radar pattern shown in Annex B.1



A D T

802.11n HT40

Type 6 Radar Statistical Performances				
Trial #	Pulses per Burst	Pulse Width (s)	PRI (s)	Detection
1	9	1.0u	333.0u	Yes
2	9	1.0u	333.0u	Yes
3	9	1.0u	333.0u	Yes
4	9	1.0u	333.0u	Yes
5	9	1.0u	333.0u	Yes
6	9	1.0u	333.0u	Yes
7	9	1.0u	333.0u	Yes
8	9	1.0u	333.0u	Yes
9	9	1.0u	333.0u	Yes
10	9	1.0u	333.0u	Yes
11	9	1.0u	333.0u	Yes
12	9	1.0u	333.0u	Yes
13	9	1.0u	333.0u	Yes
14	9	1.0u	333.0u	Yes
15	9	1.0u	333.0u	Yes
16	9	1.0u	333.0u	Yes
17	9	1.0u	333.0u	Yes
18	9	1.0u	333.0u	Yes
19	9	1.0u	333.0u	Yes
20	9	1.0u	333.0u	Yes
21	9	1.0u	333.0u	Yes
22	9	1.0u	333.0u	Yes
23	9	1.0u	333.0u	Yes
24	9	1.0u	333.0u	Yes
25	9	1.0u	333.0u	Yes
26	9	1.0u	333.0u	Yes
27	9	1.0u	333.0u	Yes
28	9	1.0u	333.0u	Yes
29	9	1.0u	333.0u	Yes
30	9	1.0u	333.0u	Yes
				Detection Rate: 100.0 %



802.11n HT40

Type 6 Radar Statistical Performances

Trial #	Hopping Frequency Sequence Name	Detection
1	HOP_FREQ_SEQ_HT40_01	Yes
2	HOP_FREQ_SEQ_HT40_02	Yes
3	HOP_FREQ_SEQ_HT40_03	Yes
4	HOP_FREQ_SEQ_HT40_04	Yes
5	HOP_FREQ_SEQ_HT40_05	Yes
6	HOP_FREQ_SEQ_HT40_06	Yes
7	HOP_FREQ_SEQ_HT40_07	Yes
8	HOP_FREQ_SEQ_HT40_08	Yes
9	HOP_FREQ_SEQ_HT40_09	Yes
10	HOP_FREQ_SEQ_HT40_10	Yes
11	HOP_FREQ_SEQ_HT40_11	Yes
12	HOP_FREQ_SEQ_HT40_12	Yes
13	HOP_FREQ_SEQ_HT40_13	Yes
14	HOP_FREQ_SEQ_HT40_14	Yes
15	HOP_FREQ_SEQ_HT40_15	Yes
16	HOP_FREQ_SEQ_HT40_16	Yes
17	HOP_FREQ_SEQ_HT40_17	Yes
18	HOP_FREQ_SEQ_HT40_18	Yes
19	HOP_FREQ_SEQ_HT40_19	Yes
20	HOP_FREQ_SEQ_HT40_20	Yes
21	HOP_FREQ_SEQ_HT40_21	Yes
22	HOP_FREQ_SEQ_HT40_22	Yes
23	HOP_FREQ_SEQ_HT40_23	Yes
24	HOP_FREQ_SEQ_HT40_24	Yes
25	HOP_FREQ_SEQ_HT40_25	Yes
26	HOP_FREQ_SEQ_HT40_26	Yes
27	HOP_FREQ_SEQ_HT40_27	Yes
28	HOP_FREQ_SEQ_HT40_28	Yes
29	HOP_FREQ_SEQ_HT40_29	Yes
30	HOP_FREQ_SEQ_HT40_30	Yes

Detection Rate: 100.0 %

The Frequency Hopping Radar pattern shown in Annex B.2

6.2.1.4 NON- OCCUPANCY PERIOD

1) Test results demonstrating an associated client link is established with the master on a test frequency.

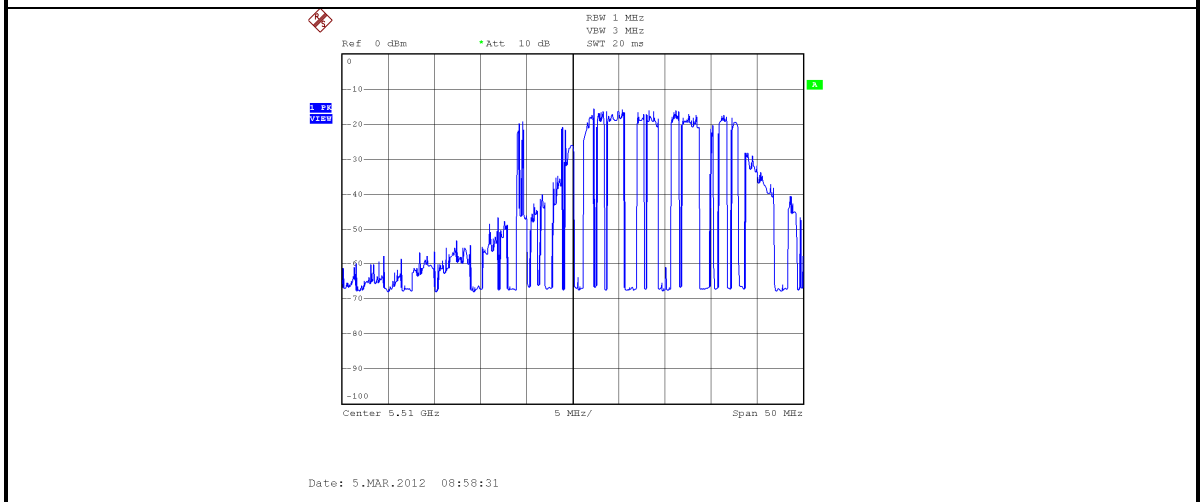

EUT (master) links with Client on 5510MHz

2) The master and DFS-certified client device are associated, and the movie can be streamed as specified in the DFS Order for a non-occupancy period test.

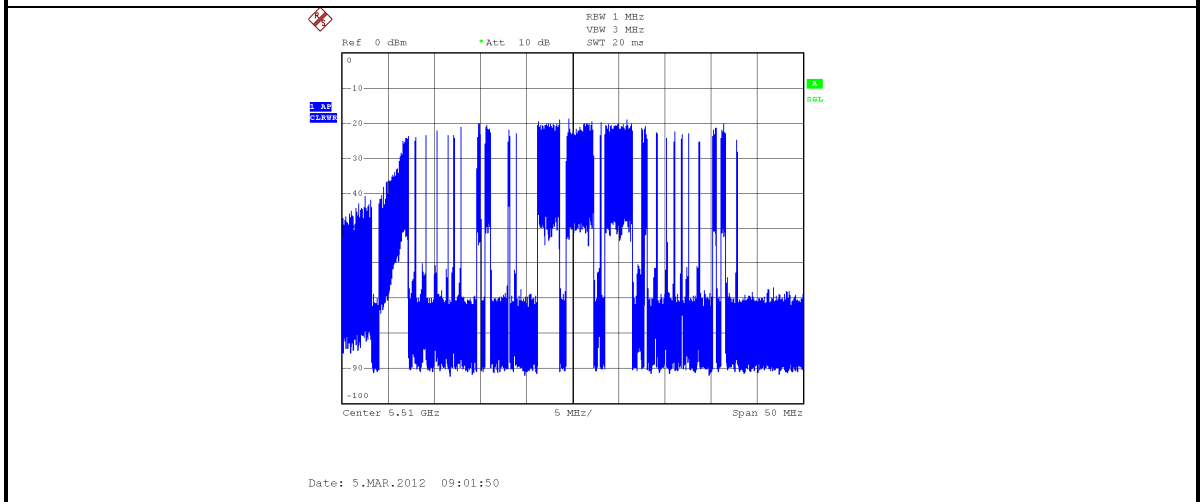

Client plays a specified files via master.

3). The device transmits one type of radar as specified in the DFS Order.

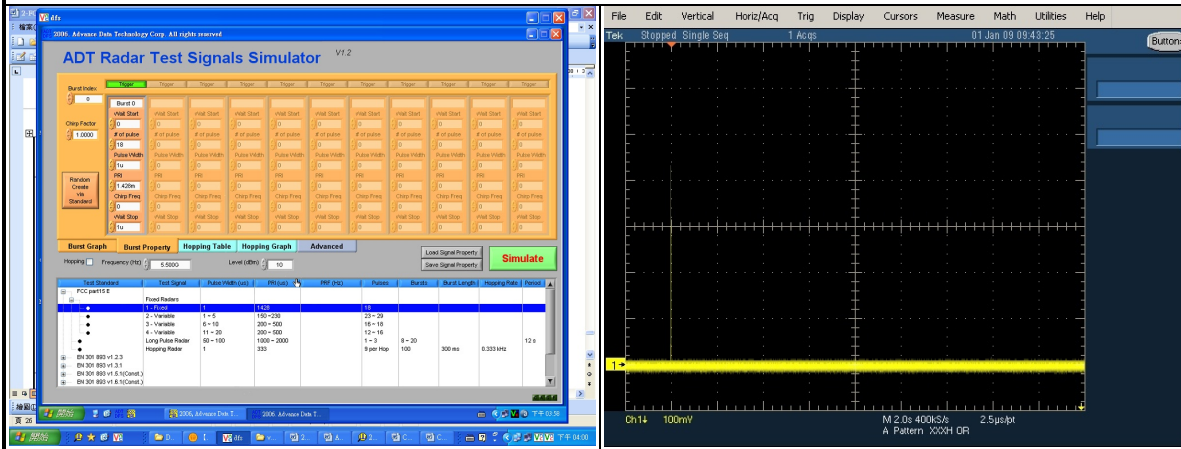

Radar 1 is used to test during DFS testing.

4) The test frequency has been monitored to ensure no transmission of any type has occurred for 30 minutes;

Note: If the client moves with the master, the device is considered compliant if nothing appears in the client non-occupancy period test. For devices that shut down (rather than moving channels), no beacons should appear;

5) An analyzer plot that contains a single 30-minute sweep on the original test frequency.

Non - Occupancy Period @ CH102 - 5510MHz

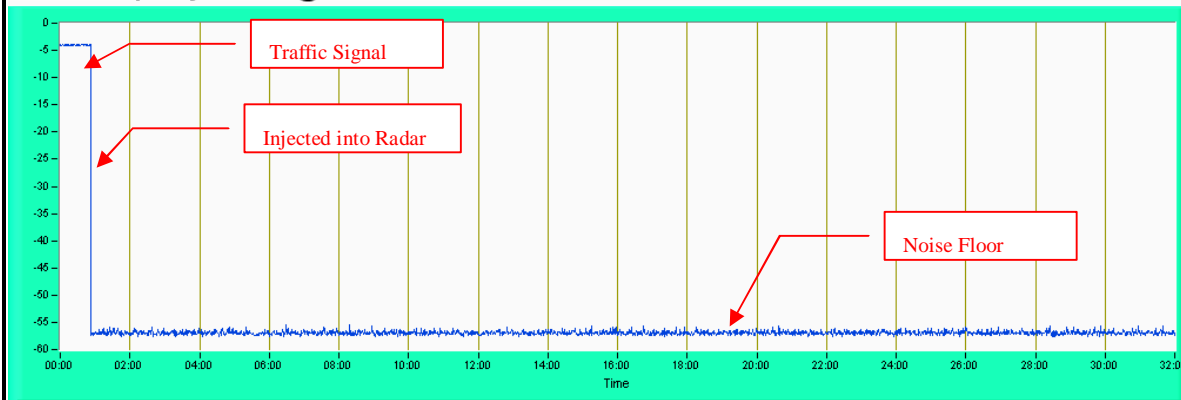



A D T

6.2.1.5 UNIFORM SPREADING

The manufacturer declare:

The intention of the uniform spreading is to provide, on aggregate, a uniform loading of the spectrum. The UUT using the bands 5150 to 5350MHz and 5470 to 5850 MHz shall select an operating channel out of the 21 channels, so that the probability of selecting a given channel shall be the same for all channels.

The UUT will select channel by random mode and remember this channel when detect radar signal, so that will select unused channel by random mode.

6.2.1.6 U-NII DETECTION BANDWIDTH

802.11n HT20

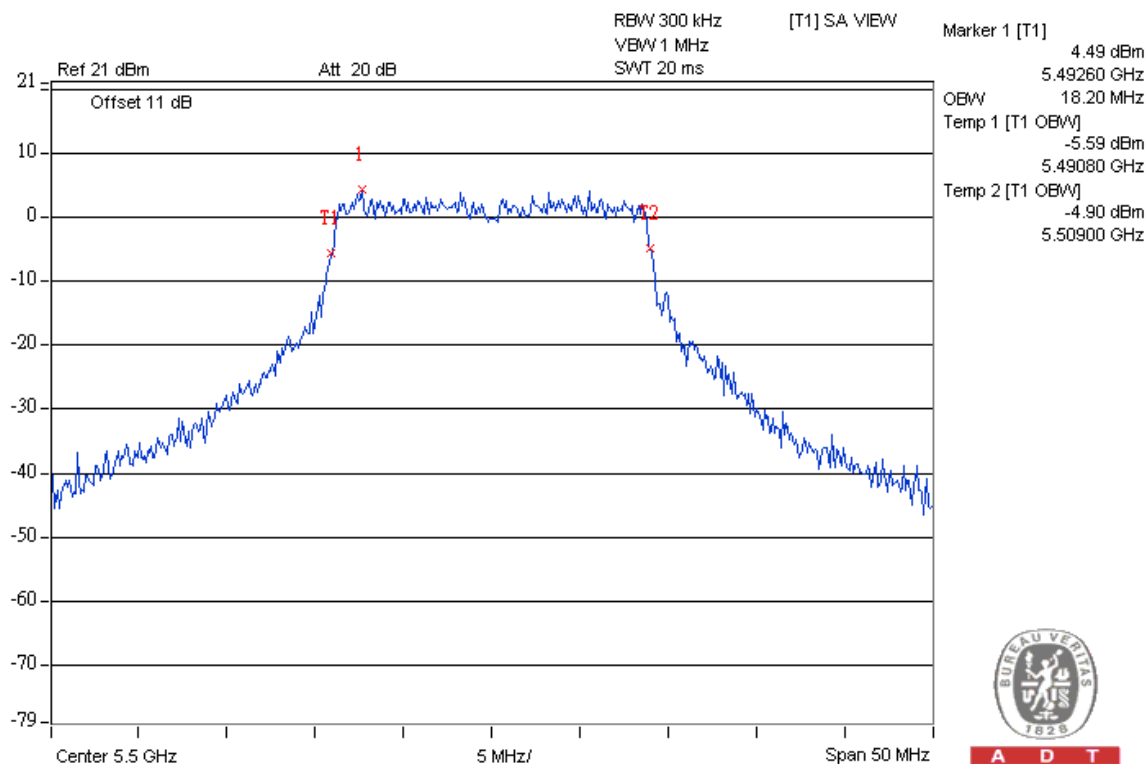

A D T

U-NII 99% Channel bandwidth



802.11n HT20

Detection Bandwidth Test
 EUT Frequency: 5.500GHz
 EUT 99% Power bandwidth: 18.20MHz
 Detection bandwidth limit (80% of EUT 99% Power bandwidth): 14.56MHz
 Detection Bandwidth (FH - FL): 22.00MHz
 Test Result : PASS

Radar Frequency (Hz)	Trial Number / Detection										Detection Rate (%)
	1	2	3	4	5	6	7	8	9	10	
5.488G	No	No	No	No	No	No	No	No	No	No	0
5.489G (FL)	Yes	Yes	Yes	Yes	Yes	Yes	Yes	Yes	Yes	Yes	100
5.490G	Yes	Yes	Yes	Yes	Yes	Yes	Yes	Yes	Yes	Yes	100
5.491G	Yes	Yes	Yes	Yes	Yes	Yes	Yes	Yes	Yes	Yes	100
5.492G	Yes	Yes	Yes	Yes	Yes	Yes	Yes	Yes	Yes	Yes	100
5.493G	Yes	Yes	Yes	Yes	Yes	Yes	Yes	Yes	Yes	Yes	100
5.494G	Yes	Yes	Yes	Yes	Yes	Yes	Yes	Yes	Yes	Yes	100
5.495G	Yes	Yes	Yes	Yes	Yes	Yes	Yes	Yes	Yes	Yes	100
5.496G	Yes	Yes	Yes	Yes	Yes	Yes	Yes	Yes	Yes	Yes	100
5.497G	Yes	Yes	Yes	Yes	Yes	Yes	Yes	Yes	Yes	Yes	100
5.498G	Yes	Yes	Yes	Yes	Yes	Yes	Yes	Yes	Yes	Yes	100
5.499G	Yes	Yes	Yes	Yes	Yes	Yes	Yes	Yes	Yes	Yes	100
5.500G	Yes	Yes	Yes	Yes	Yes	Yes	Yes	Yes	Yes	Yes	100
5.501G	Yes	Yes	Yes	Yes	Yes	Yes	Yes	Yes	Yes	Yes	100
5.502G	Yes	Yes	Yes	Yes	Yes	Yes	Yes	Yes	Yes	Yes	100
5.503G	Yes	Yes	Yes	Yes	Yes	Yes	Yes	Yes	Yes	Yes	100
5.504G	Yes	Yes	Yes	Yes	Yes	Yes	Yes	Yes	Yes	Yes	100
5.505G	Yes	Yes	Yes	Yes	Yes	Yes	Yes	Yes	Yes	Yes	100
5.506G	Yes	Yes	Yes	Yes	Yes	Yes	Yes	Yes	Yes	Yes	100
5.507G	Yes	Yes	Yes	Yes	Yes	Yes	Yes	Yes	Yes	Yes	100
5.508G	Yes	Yes	Yes	Yes	Yes	Yes	Yes	Yes	Yes	Yes	100
5.509G	Yes	Yes	Yes	Yes	Yes	Yes	Yes	Yes	Yes	Yes	100
5.510G	Yes	Yes	Yes	Yes	Yes	Yes	Yes	Yes	Yes	Yes	100
5.511G(FH)	Yes	Yes	Yes	Yes	Yes	Yes	Yes	Yes	Yes	Yes	100
5.512G	No	No	No	No	No	No	No	No	No	No	0



A D T

802.11n HT40

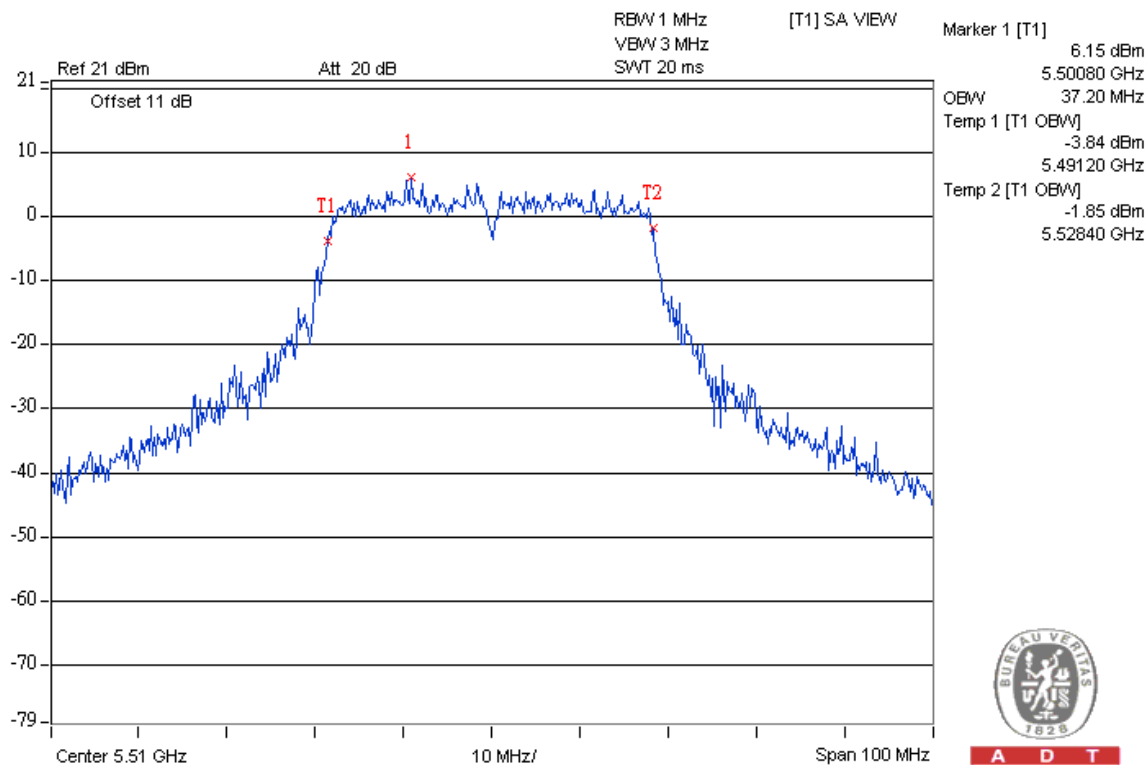

A D T

U-NII 99% Channel bandwidth



A D T

802.11n HT40

Detection Bandwidth Test											
EUT Frequency: 5.510GHz											
EUT 99% Power bandwidth: 37.20MHz											
Detection bandwidth limit (80% of EUT 99% Power bandwidth): 29.76MHz											
Detection Bandwidth (FH - FL): 42.00MHz											
Test Result : PASS											
Radar	Trial Number / Detection										Detection Rate (%)
Frequency (Hz)	1	2	3	4	5	6	7	8	9	10	
5.488G	No	No	No	No	No	No	No	No	No	No	0
5.489G (FL)	Yes	Yes	Yes	Yes	Yes	Yes	Yes	Yes	Yes	Yes	100
5.490G	Yes	Yes	Yes	Yes	Yes	Yes	Yes	Yes	Yes	Yes	100
5.491G	Yes	Yes	Yes	Yes	Yes	Yes	Yes	Yes	Yes	Yes	100
5.492G	Yes	Yes	Yes	Yes	Yes	Yes	Yes	Yes	Yes	Yes	100
5.493G	Yes	Yes	Yes	Yes	Yes	Yes	Yes	Yes	Yes	Yes	100
5.494G	Yes	Yes	Yes	Yes	Yes	Yes	Yes	Yes	Yes	Yes	100
5.495G	Yes	Yes	Yes	Yes	Yes	Yes	Yes	Yes	Yes	Yes	100
5.496G	Yes	Yes	Yes	Yes	Yes	Yes	Yes	Yes	Yes	Yes	100
5.497G	Yes	Yes	Yes	Yes	Yes	Yes	Yes	Yes	Yes	Yes	100
5.498G	Yes	Yes	Yes	Yes	Yes	Yes	Yes	Yes	Yes	Yes	100
5.499G	Yes	Yes	Yes	Yes	Yes	Yes	Yes	Yes	Yes	Yes	100
5.500G	Yes	Yes	Yes	Yes	Yes	Yes	Yes	Yes	Yes	Yes	100
5.501G	Yes	Yes	Yes	Yes	Yes	Yes	Yes	Yes	Yes	Yes	100
5.502G	Yes	Yes	Yes	Yes	Yes	Yes	Yes	Yes	Yes	Yes	100
5.503G	Yes	Yes	Yes	Yes	Yes	Yes	Yes	Yes	Yes	Yes	100
5.504G	Yes	Yes	Yes	Yes	Yes	Yes	Yes	Yes	Yes	Yes	100
5.505G	Yes	Yes	Yes	Yes	Yes	Yes	Yes	Yes	Yes	Yes	100
5.506G	Yes	Yes	Yes	Yes	Yes	Yes	Yes	Yes	Yes	Yes	100
5.507G	Yes	Yes	Yes	Yes	Yes	Yes	Yes	Yes	Yes	Yes	100
5.508G	Yes	Yes	Yes	Yes	Yes	Yes	Yes	Yes	Yes	Yes	100
5.509G	Yes	Yes	Yes	Yes	Yes	Yes	Yes	Yes	Yes	Yes	100
5.510G	Yes	Yes	Yes	Yes	Yes	Yes	Yes	Yes	Yes	Yes	100
5.511G	Yes	Yes	Yes	Yes	Yes	Yes	Yes	Yes	Yes	Yes	100
5.512G	Yes	Yes	Yes	Yes	Yes	Yes	Yes	Yes	Yes	Yes	100
5.513G	Yes	Yes	Yes	Yes	Yes	Yes	Yes	Yes	Yes	Yes	100
5.514G	Yes	Yes	Yes	Yes	Yes	Yes	Yes	Yes	Yes	Yes	100
5.515G	Yes	Yes	Yes	Yes	Yes	Yes	Yes	Yes	Yes	Yes	100
5.516G	Yes	Yes	Yes	Yes	Yes	Yes	Yes	Yes	Yes	Yes	100
5.517G	Yes	Yes	Yes	Yes	Yes	Yes	Yes	Yes	Yes	Yes	100
5.518G	Yes	Yes	Yes	Yes	Yes	Yes	Yes	Yes	Yes	Yes	100
5.519G	Yes	Yes	Yes	Yes	Yes	Yes	Yes	Yes	Yes	Yes	100
5.520G	Yes	Yes	Yes	Yes	Yes	Yes	Yes	Yes	Yes	Yes	100
5.521G	Yes	Yes	Yes	Yes	Yes	Yes	Yes	Yes	Yes	Yes	100
5.522G	Yes	Yes	Yes	Yes	Yes	Yes	Yes	Yes	Yes	Yes	100
5.523G	Yes	Yes	Yes	Yes	Yes	Yes	Yes	Yes	Yes	Yes	100
5.524G	Yes	Yes	Yes	Yes	Yes	Yes	Yes	Yes	Yes	Yes	100
5.525G	Yes	Yes	Yes	Yes	Yes	Yes	Yes	Yes	Yes	Yes	100
5.526G	Yes	Yes	Yes	Yes	Yes	Yes	Yes	Yes	Yes	Yes	100
5.527G	Yes	Yes	Yes	Yes	Yes	Yes	Yes	Yes	Yes	Yes	100
5.528G	Yes	Yes	Yes	Yes	Yes	Yes	Yes	Yes	Yes	Yes	100
5.529G	Yes	Yes	Yes	Yes	Yes	Yes	Yes	Yes	Yes	Yes	100
5.530G	Yes	Yes	Yes	Yes	Yes	Yes	Yes	Yes	Yes	Yes	100
5.531G(FH)	Yes	Yes	Yes	Yes	Yes	Yes	Yes	Yes	Yes	Yes	100
5.532G	No	Yes	No	No	No	No	No	No	No	No	10



A D T

6.2.1.7 NON-CO-CHANNEL TEST

The UUT was investigated after radar was detected the channel and made sure no co-channel operation with radars.

6.2.1.8 TRANSMIT POWER CONTROL (TPC)

Maximum EIRP of this device is 143.549mW which less than 500mW, therefore it's not require TPC function.

6.2.2. TEST MODE: DEVICE OPERATING IN CLIENT WITHOUT RADAR DETECTION MODE.

Client with injection at the Master. (The radar test signals are injected into the Master Device.

6.2.2.1 DFS DETECTION THRESHOLD

For a detection threshold level of -62dBm and the Master antenna gain is $(-0.4)\text{dBi}$. The Required detection threshold is -61.4dBm ($= -62 + (-0.4) + 1$) dBm . The conducted radar burst level is set to -61.4dBm .

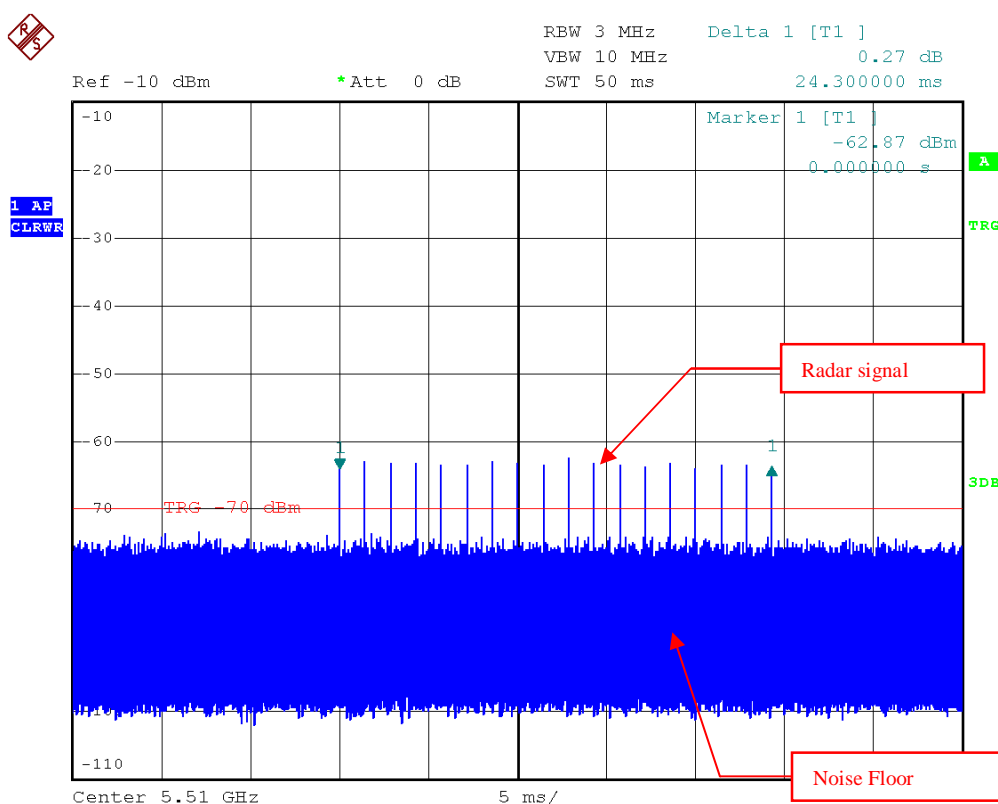

Radar Signal 1

6.2.2.2 CHANNEL CLOSING TRANSMISSION AND CHANNEL MOVE TIME

Channel Closing Transmission Time & Channel Move Time @ CH102 - 5510MHz

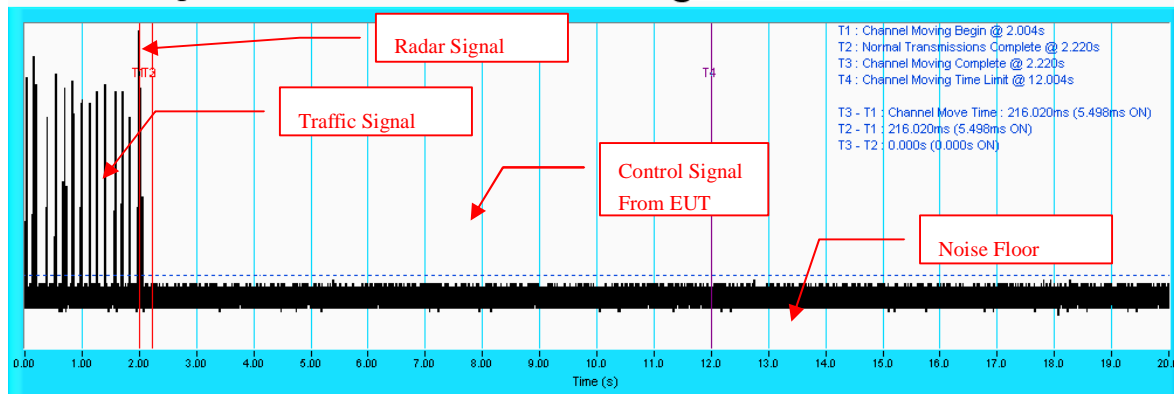

NOTE: T1 denotes the start of Channel Move Time upon the end of the last Radar burst. T2 denotes the data transmission time of 200ms from T1. T4 denotes the 10 second from T1 to observe the aggregate duration of transmissions.

Channel Closing Transmission Time & Channel Move Time @ CH102 - 5510MHz

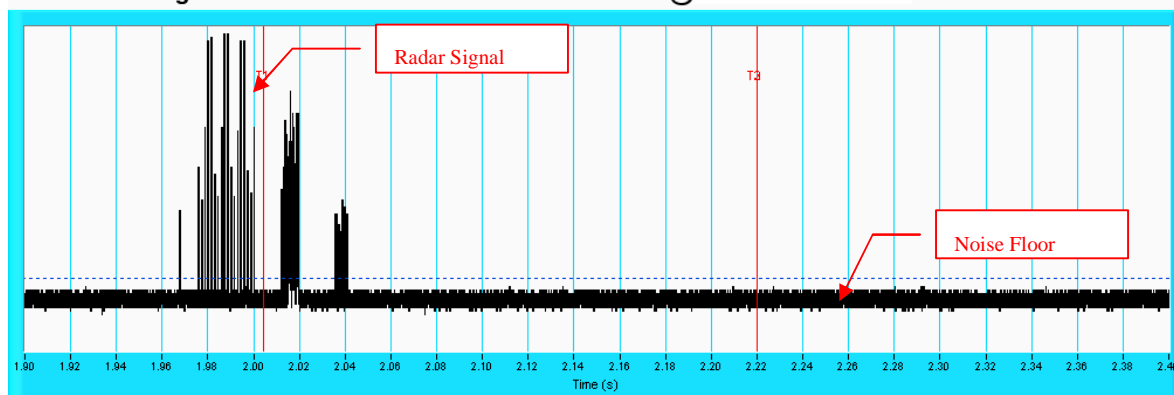

NOTE: An expanded plot for the device vacates the channel in the required 500ms.

6.2.2.3 NON- OCCUPANCY PERIOD

ASSOCIATED TEST

1) Test results demonstrating an associated client link is established with the master on a test frequency.

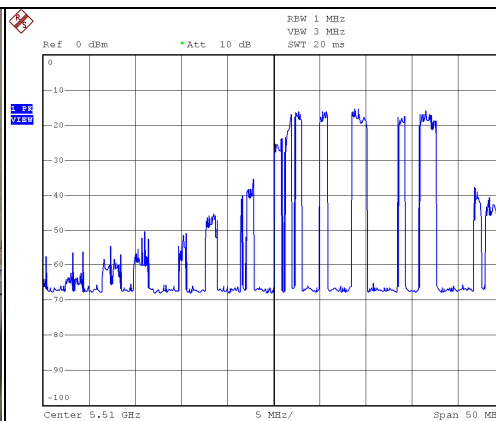

Date: 5.MAR.2012 08:48:56

EUT (Client) links with master on 5510MHz

2) The client and DFS-certified master device are associated, and the movie can be streamed as specified in the DFS Order for a non-occupancy period test.

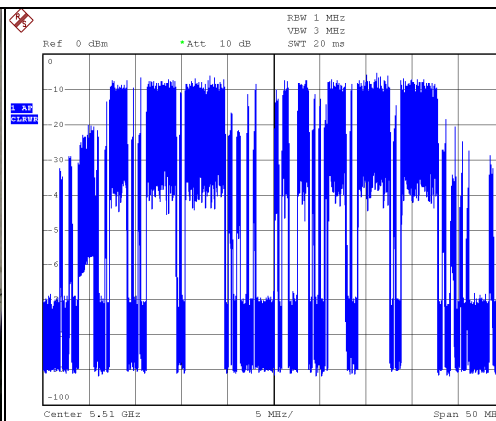

Date: 5.MAR.2012 08:56:34

Client plays a specified files via master.

3). The device transmits one type of radar as specified in the DFS Order.

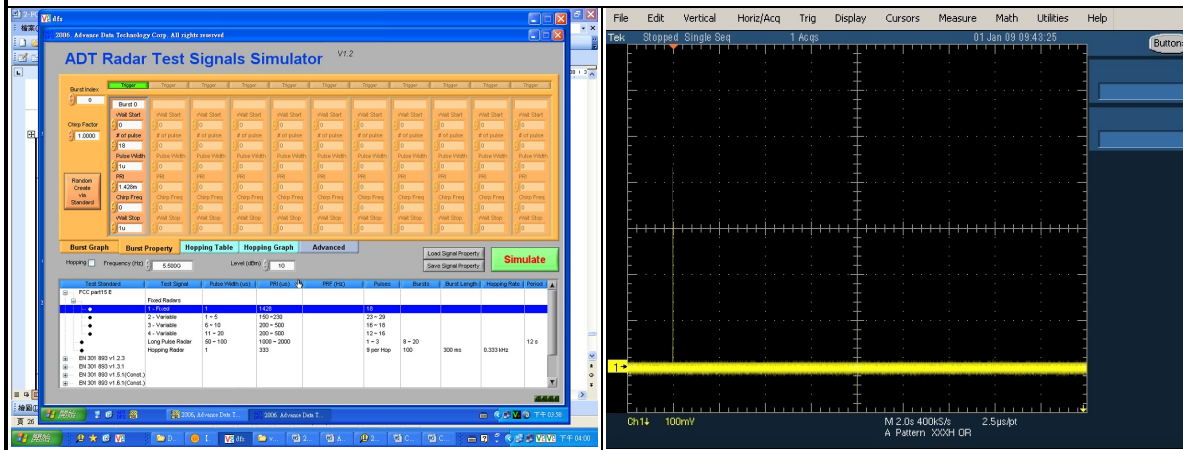

Radar 1 is used to test during DFS testing.

4) The test frequency has been monitored to ensure no transmission of any type has occurred for 30 minutes;

Note: If the client moves with the master, the device is considered compliant if nothing appears in the client non-occupancy period test. For devices that shut down (rather than moving channels), no beacons should appear;

5)An analyzer plot that contains a single 30-minute sweep on the original test frequency.

Non - Occupancy Period @ CH102 - 5510MHz

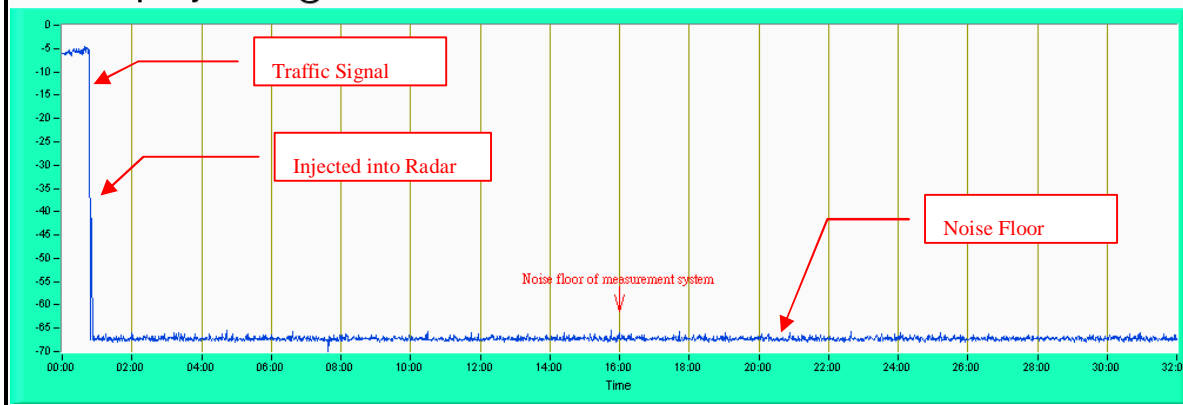

NON-ASSOCIATED TEST

Master was off.

During the 30 minutes observation time, The UUT did not make any transmissions in the DFS band after UUT power up.

Non - Associated Test @ CH102 - 5510MHz

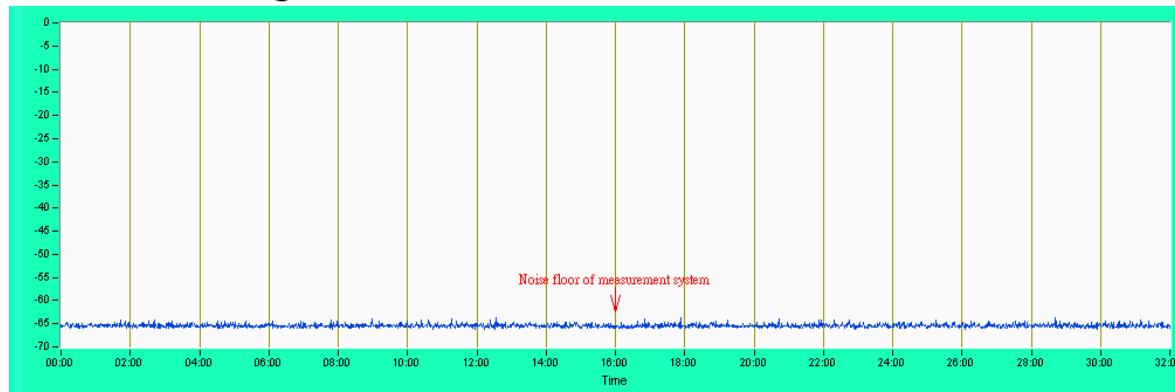

6.2.2.4 NON- CO-CHANNEL TEST

The UUT was investigated after radar was detected the channel and made sure no co-channel operation with radars.



A D T

7 INFORMATION ON THE TESTING LABORATORIES

We, Bureau Veritas Consumer Products Services (H.K.) Ltd., Taoyuan Branch, were founded in 1988 to provide our best service in EMC, Radio, Telecom and Safety consultation. Our laboratories are accredited and approved according to ISO/IEC 17025.

If you have any comments, please feel free to contact us at the following:

Linko EMC/RF Lab:

Tel: 886-2-26052180

Fax: 886-2-26052943

Hsin Chu EMC/RF Lab:

Tel: 886-3-5935343

Fax: 886-3-5935342

Hwa Ya EMC/RF/Safety/Telecom Lab:

Tel: 886-3-3183232

Fax: 886-3-3270892

Email: service.adt@tw.bureauveritas.com

Web Site: www.adt.com.tw

The address and road map of all our labs can be found in our web site also.



A D T

8 APPENDIX-A

Modifications or adding components during the test

No any modifications are made to the EUT by the lab during the test.



9 APPENDIX-B

RADAR TEST SIGNAL

B.1 The Long Pulse Radar Pattern

Long Pulse Radar Test Signal						
Test Signal Name: LP_HT20_Signal_01						
Number of Bursts in Trial: 15						
Burst	Pulses per Burst	Chrip (Hz)	Pulse Width (s)	Pulse 1 to 2 Spacing (s)	Pulse 2 to 3 Spacing (s)	Start Location (s)
1	2	14M	51.9u	1.469m	-	268.4m
2	2	8M	61.8u	1.795m	-	283.4m
3	3	9M	65.5u	1.159m	1.829m	353.4m
4	2	7M	58.6u	1.198m	-	579.5m
5	2	15M	54.2u	1.203m	-	279.7m
6	2	13M	67.0u	1.714m	-	376.8m
7	2	12M	96.4u	1.771m	-	226.1m
8	1	8M	82.8u	-	-	560.2m
9	2	17M	51.0u	1.795m	-	614.4m
10	2	5M	70.7u	1.041m	-	450.6m
11	1	9M	76.8u	-	-	318.3m
12	3	7M	69.1u	1.790m	1.275m	388.0m
13	3	18M	55.1u	1.283m	1.660m	598.2m
14	2	20M	78.0u	1.361m	-	55.53m
15	3	18M	98.6u	1.280m	1.251m	715.1m

Long Pulse Radar Test Signal						
Test Signal Name: LP_HT20_Signal_02						
Number of Bursts in Trial: 8						
Burst	Pulses per Burst	Chrip (Hz)	Pulse Width (s)	Pulse 1 to 2 Spacing (s)	Pulse 2 to 3 Spacing (s)	Start Location (s)
1	1	13M	80.5u	-	-	320.2m
2	1	12M	54.9u	-	-	1.215
3	2	13M	54.6u	1.529m	-	227.0m
4	3	12M	66.4u	1.267m	1.571m	395.3m
5	2	17M	63.1u	1.761m	-	777.7m
6	3	14M	76.1u	1.729m	1.781m	570.2m
7	2	16M	99.9u	1.476m	-	1.206
8	1	18M	82.5u	-	-	1.072



A D T

Long Pulse Radar Test Signal

Test Signal Name: LP_HT20_Signal_03

Number of Bursts in Trial: 15

Burst	Pulses per Burst	Chrip (Hz)	Pulse Width (s)	Pulse 1 to 2 Spacing (s)	Pulse 2 to 3 Spacing (s)	Start Location (s)
1	3	16M	78.3u	1.433m	1.341m	417.6m
2	2	10M	94.1u	1.844m	-	438.9m
3	1	18M	70.1u	-	-	507.3m
4	1	10M	69.0u	-	-	458.0m
5	2	10M	79.5u	1.065m	-	505.8m
6	3	6M	79.5u	1.499m	1.837m	449.1m
7	3	18M	65.5u	1.914m	1.491m	14.47m
8	1	17M	92.3u	-	-	112.6m
9	2	13M	90.1u	1.225m	-	632.4m
10	3	8M	91.8u	1.873m	1.446m	21.44m
11	2	10M	78.1u	1.780m	-	234.9m
12	1	14M	92.5u	-	-	137.6m
13	3	14M	55.5u	1.318m	1.643m	459.5m
14	1	9M	77.3u	-	-	309.2m
15	3	14M	65.9u	1.605m	969.1u	246.6m

Long Pulse Radar Test Signal

Test Signal Name: LP_HT20_Signal_04

Number of Bursts in Trial: 10

Burst	Pulses per Burst	Chrip (Hz)	Pulse Width (s)	Pulse 1 to 2 Spacing (s)	Pulse 2 to 3 Spacing (s)	Start Location (s)
1	3	9M	58.1u	1.241m	1.184m	960.6m
2	1	18M	77.8u	-	-	209.8m
3	3	16M	61.1u	1.246m	1.167m	794.3m
4	1	12M	81.3u	-	-	649.6m
5	2	18M	82.4u	1.805m	-	1.166
6	2	15M	82.2u	1.088m	-	427.1m
7	2	13M	58.7u	1.377m	-	355.1m
8	3	5M	75.0u	1.664m	1.296m	1.050
9	3	6M	98.1u	1.459m	1.816m	847.2m
10	1	14M	75.0u	-	-	340.9m



A D T

Long Pulse Radar Test Signal

Test Signal Name: LP_HT20_Signal_05

Number of Bursts in Trial: 17

Burst	Pulses per Burst	Chrip (Hz)	Pulse Width (s)	Pulse 1 to 2 Spacing (s)	Pulse 2 to 3 Spacing (s)	Start Location (s)
1	2	8M	86.4u	941.6u	-	621.8m
2	1	13M	71.7u	-	-	309.3m
3	2	7M	57.2u	1.616m	-	278.4m
4	2	12M	94.9u	925.1u	-	593.5m
5	2	13M	65.3u	973.7u	-	490.1m
6	3	9M	84.9u	1.533m	1.174m	512.6m
7	2	9M	56.0u	1.883m	-	447.1m
8	1	18M	73.0u	-	-	121.2m
9	2	14M	77.5u	1.714m	-	115.6m
10	1	11M	81.7u	-	-	516.7m
11	3	19M	75.4u	959.6u	1.146m	142.6m
12	2	11M	71.2u	1.552m	-	178.8m
13	1	9M	96.6u	-	-	255.6m
14	3	19M	89.6u	1.430m	1.898m	408.5m
15	2	20M	95.6u	1.302m	-	436.0m
16	2	11M	64.3u	1.195m	-	58.88m
17	3	12M	77.1u	1.288m	1.192m	138.3m

Long Pulse Radar Test Signal

Test Signal Name: LP_HT20_Signal_06

Number of Bursts in Trial: 17

Burst	Pulses per Burst	Chrip (Hz)	Pulse Width (s)	Pulse 1 to 2 Spacing (s)	Pulse 2 to 3 Spacing (s)	Start Location (s)
1	2	9M	51.2u	1.941m	-	203.6m
2	1	10M	57.0u	-	-	534.2m
3	2	12M	63.4u	1.378m	-	456.0m
4	3	15M	57.0u	1.443m	1.612m	33.74m
5	2	19M	74.1u	1.304m	-	2.045m
6	3	7M	73.3u	1.631m	1.224m	553.0m
7	1	13M	83.6u	-	-	700.6m
8	2	11M	78.5u	1.707m	-	202.3m
9	3	18M	94.8u	1.389m	1.780m	699.6m
10	2	12M	80.1u	1.510m	-	694.8m
11	1	12M	88.1u	-	-	249.5m
12	1	12M	63.7u	-	-	463.4m
13	3	10M	85.8u	1.748m	1.409m	644.1m
14	3	6M	85.4u	928.6u	1.700m	147.0m



A D T

15	1	19M	86.9u	-	-	586.7m
16	3	9M	68.0u	1.659m	1.527m	22.16m
17	2	17M	55.1u	1.067m	-	687.1m

Long Pulse Radar Test Signal
 Test Signal Name: LP_HT20_Signal_07
 Number of Bursts in Trial: 13

Burst	Pulses per Burst	Chrip (Hz)	Pulse Width (s)	Pulse 1 to 2 Spacing (s)	Pulse 2 to 3 Spacing (s)	Start Location (s)
1	1	5M	94.7u	-	-	266.7m
2	2	14M	88.0u	1.710m	-	427.9m
3	3	15M	81.0u	926.0u	1.529m	541.6m
4	1	16M	56.9u	-	-	657.7m
5	1	11M	75.6u	-	-	148.9m
6	3	12M	68.1u	1.735m	1.092m	147.0m
7	1	13M	60.4u	-	-	351.0m
8	1	14M	95.6u	-	-	201.2m
9	2	19M	95.9u	1.433m	-	799.5m
10	2	20M	64.0u	1.696m	-	11.74m
11	2	12M	60.3u	1.243m	-	376.5m
12	3	17M	98.4u	1.347m	1.660m	884.3m
13	2	19M	73.0u	1.513m	-	256.7m

Long Pulse Radar Test Signal
 Test Signal Name: LP_HT20_Signal_08
 Number of Bursts in Trial: 9

Burst	Pulses per Burst	Chrip (Hz)	Pulse Width (s)	Pulse 1 to 2 Spacing (s)	Pulse 2 to 3 Spacing (s)	Start Location (s)
1	1	15M	71.3u	-	-	78.68m
2	3	9M	64.2u	1.201m	1.782m	119.9m
3	1	6M	88.3u	-	-	1.315
4	3	19M	56.0u	1.934m	1.403m	126.5m
5	1	7M	74.2u	-	-	440.3m
6	2	16M	85.0u	1.335m	-	446.7m
7	2	18M	99.1u	1.335m	-	905.3m
8	2	18M	81.5u	1.584m	-	719.0m
9	2	13M	75.4u	1.203m	-	98.62m

Long Pulse Radar Test Signal
 Test Signal Name: LP_HT20_Signal_09
 Number of Bursts in Trial: 12

Burst	Pulses per Burst	Chrip (Hz)	Pulse Width (s)	Pulse 1 to 2 Spacing (s)	Pulse 2 to 3 Spacing (s)	Start Location (s)
-------	------------------	------------	-----------------	--------------------------	--------------------------	--------------------



A D T

	Burst					
1	1	7M	66.8u	-	-	416.0m
2	3	11M	62.4u	1.304m	1.586m	664.6m
3	2	9M	73.7u	1.109m	-	842.9m
4	2	14M	85.1u	941.9u	-	538.1m
5	1	11M	77.3u	-	-	964.1m
6	2	20M	98.7u	1.659m	-	472.4m
7	2	7M	57.6u	1.482m	-	364.5m
8	1	10M	63.5u	-	-	408.4m
9	2	9M	70.9u	1.207m	-	993.9m
10	2	19M	89.9u	1.412m	-	148.0m
11	1	11M	95.6u	-	-	238.1m
12	2	10M	92.3u	1.905m	-	550.0m

Long Pulse Radar Test Signal

Test Signal Name: LP_HT20_Signal_10

Number of Bursts in Trial: 11

Burst	Pulses per Burst	Chrip (Hz)	Pulse Width (s)	Pulse 1 to 2 Spacing (s)	Pulse 2 to 3 Spacing (s)	Start Location (s)
1	2	8M	96.1u	943.9u	-	255.5m
2	2	14M	78.2u	1.277m	-	364.2m
3	2	11M	53.7u	993.3u	-	289.8m
4	3	7M	80.9u	1.335m	1.257m	721.1m
5	1	9M	67.7u	-	-	488.3m
6	2	18M	89.7u	1.569m	-	352.5m
7	2	17M	76.6u	1.425m	-	154.8m
8	3	10M	62.0u	1.735m	1.646m	250.4m
9	1	8M	66.7u	-	-	696.6m
10	3	16M	75.3u	1.372m	1.149m	863.0m
11	3	18M	92.3u	1.268m	1.725m	690.6m

Long Pulse Radar Test Signal

Test Signal Name: LP_HT20_Signal_11

Number of Bursts in Trial: 19

Burst	Pulses per Burst	Chrip (Hz)	Pulse Width (s)	Pulse 1 to 2 Spacing (s)	Pulse 2 to 3 Spacing (s)	Start Location (s)
1	2	8M	95.4u	1.774m	-	231.1m
2	2	19M	52.3u	1.640m	-	495.9m
3	1	20M	98.8u	-	-	478.7m
4	2	9M	88.5u	1.469m	-	504.4m
5	1	10M	69.9u	-	-	87.71m
6	3	9M	88.7u	1.724m	1.244m	618.2m
7	3	20M	98.7u	1.501m	1.861m	407.5m



A D T

8	2	16M	54.4u	1.390m	-	608.2m
9	1	14M	98.7u	-	-	103.3m
10	2	6M	51.9u	1.857m	-	94.43m
11	2	10M	50.0u	1.140m	-	72.45m
12	2	8M	61.7u	1.223m	-	52.89m
13	2	18M	76.4u	1.012m	-	63.22m
14	3	13M	85.5u	1.311m	1.198m	92.24m
15	1	8M	75.7u	-	-	344.7m
16	2	9M	78.3u	1.249m	-	372.0m
17	2	6M	83.9u	1.513m	-	51.40m
18	2	12M	63.0u	1.742m	-	23.00m
19	2	15M	72.3u	1.475m	-	528.7m

Long Pulse Radar Test Signal						
Test Signal Name: LP_HT20_Signal_12						
Number of Bursts in Trial: 13						
Burst	Pulses per Burst	Chrip (Hz)	Pulse Width (s)	Pulse 1 to 2 Spacing (s)	Pulse 2 to 3 Spacing (s)	Start Location (s)
1	3	5M	64.2u	1.784m	1.291m	572.7m
2	3	15M	99.2u	1.409m	952.8u	853.0m
3	2	15M	97.5u	952.5u	-	138.3m
4	1	16M	90.7u	-	-	117.4m
5	2	8M	53.2u	1.234m	-	47.49m
6	1	15M	94.1u	-	-	276.2m
7	2	13M	73.0u	1.115m	-	399.7m
8	3	19M	80.4u	1.377m	1.384m	604.9m
9	3	7M	65.7u	1.382m	1.305m	459.1m
10	2	7M	84.1u	1.733m	-	735.7m
11	3	8M	99.2u	1.631m	1.390m	353.0m
12	2	8M	98.1u	1.733m	-	449.4m
13	2	11M	68.1u	1.702m	-	158.7m

Long Pulse Radar Test Signal						
Test Signal Name: LP_HT20_Signal_13						
Number of Bursts in Trial: 8						
Burst	Pulses per Burst	Chrip (Hz)	Pulse Width (s)	Pulse 1 to 2 Spacing (s)	Pulse 2 to 3 Spacing (s)	Start Location (s)
1	2	8M	52.4u	1.039m	-	696.0m
2	2	19M	77.4u	1.657m	-	1.045
3	2	11M	97.8u	1.354m	-	978.7m
4	3	16M	89.0u	947.0u	1.715m	556.6m
5	3	12M	59.3u	1.202m	1.408m	778.8m
6	1	11M	95.9u	-	-	430.9m



A D T

7	3	13M	55.4u	1.161m	1.581m	1.245
8	2	16M	65.7u	1.678m	-	105.9m

Long Pulse Radar Test Signal

Test Signal Name: LP_HT20_Signal_14

Number of Bursts in Trial: 19

Burst	Pulses per Burst	Chrip (Hz)	Pulse Width (s)	Pulse 1 to 2 Spacing (s)	Pulse 2 to 3 Spacing (s)	Start Location (s)
1	3	9M	56.2u	1.871m	1.674m	334.6m
2	1	11M	84.0u	-	-	165.7m
3	2	9M	61.3u	1.381m	-	146.6m
4	1	9M	58.2u	-	-	250.1m
5	2	7M	53.0u	1.123m	-	574.6m
6	3	18M	78.2u	987.8u	947.8u	465.7m
7	1	8M	69.5u	-	-	364.4m
8	3	13M	91.5u	1.110m	1.380m	247.2m
9	3	14M	97.7u	1.654m	991.3u	110.0m
10	3	5M	88.7u	1.277m	1.869m	209.9m
11	3	12M	57.3u	1.407m	1.401m	233.2m
12	2	17M	96.8u	1.025m	-	101.3m
13	2	16M	79.9u	1.284m	-	204.8m
14	3	19M	99.4u	1.573m	1.427m	232.1m
15	2	19M	86.0u	1.328m	-	292.1m
16	3	5M	55.2u	1.668m	1.141m	593.6m
17	2	14M	59.5u	1.360m	-	204.7m
18	2	12M	66.2u	1.844m	-	78.96m
19	2	18M	98.4u	1.137m	-	500.8m

Long Pulse Radar Test Signal

Test Signal Name: LP_HT20_Signal_15

Number of Bursts in Trial: 17

Burst	Pulses per Burst	Chrip (Hz)	Pulse Width (s)	Pulse 1 to 2 Spacing (s)	Pulse 2 to 3 Spacing (s)	Start Location (s)
1	3	13M	50.0u	1.071m	1.214m	534.3m
2	3	15M	53.4u	1.245m	1.264m	391.2m
3	1	10M	53.0u	-	-	683.0m
4	1	8M	79.5u	-	-	183.8m
5	2	9M	94.3u	1.081m	-	100.0m
6	1	10M	72.9u	-	-	350.4m
7	2	18M	98.5u	1.087m	-	104.3m
8	3	13M	87.7u	1.508m	1.789m	183.2m
9	2	19M	75.5u	1.829m	-	295.3m
10	2	19M	69.2u	1.734m	-	675.4m



A D T

11	3	8M	93.3u	1.336m	1.052m	354.6m
12	2	13M	82.0u	1.501m	-	496.0m
13	1	8M	66.5u	-	-	557.5m
14	1	6M	58.8u	-	-	166.2m
15	2	20M	67.7u	1.465m	-	658.5m
16	3	5M	76.9u	1.072m	1.167m	223.0m
17	2	6M	68.7u	1.143m	-	249.9m

Long Pulse Radar Test Signal

Test Signal Name: LP_HT20_Signal_16

Number of Bursts in Trial: 16

Burst	Pulses per Burst	Chrip (Hz)	Pulse Width (s)	Pulse 1 to 2 Spacing (s)	Pulse 2 to 3 Spacing (s)	Start Location (s)
1	2	6M	72.3u	1.160m	-	74.77m
2	1	19M	65.2u	-	-	249.1m
3	3	15M	98.8u	1.416m	1.101m	17.71m
4	1	17M	71.4u	-	-	503.3m
5	3	18M	78.6u	1.074m	1.606m	674.3m
6	2	13M	68.2u	1.010m	-	98.98m
7	2	19M	85.5u	1.749m	-	684.0m
8	2	17M	96.7u	1.029m	-	533.9m
9	3	11M	59.3u	1.081m	1.560m	511.3m
10	3	18M	82.1u	1.769m	1.197m	394.3m
11	3	10M	91.0u	1.185m	1.127m	61.21m
12	2	9M	98.0u	1.163m	-	185.8m
13	2	18M	84.7u	1.606m	-	294.8m
14	2	6M	78.4u	1.513m	-	652.8m
15	3	18M	92.7u	1.611m	963.3u	533.0m
16	1	11M	87.9u	-	-	606.7m

Long Pulse Radar Test Signal

Test Signal Name: LP_HT20_Signal_17

Number of Bursts in Trial: 11

Burst	Pulses per Burst	Chrip (Hz)	Pulse Width (s)	Pulse 1 to 2 Spacing (s)	Pulse 2 to 3 Spacing (s)	Start Location (s)
1	1	12M	59.4u	-	-	502.3m
2	2	17M	75.2u	1.083m	-	899.8m
3	2	7M	68.3u	1.857m	-	975.4m
4	1	11M	98.5u	-	-	963.3m
5	2	13M	93.3u	1.568m	-	447.9m
6	2	19M	82.2u	1.199m	-	590.7m
7	1	18M	65.3u	-	-	1.028
8	2	9M	59.4u	1.334m	-	641.0m



A D T

9	2	13M	67.5u	1.812m	-	500.9m
10	3	17M	71.4u	1.629m	1.027m	127.9m
11	2	18M	83.8u	1.487m	-	536.7m

Long Pulse Radar Test Signal

Test Signal Name: LP_HT20_Signal_18

Number of Bursts in Trial: 9

Burst	Pulses per Burst	Chrip (Hz)	Pulse Width (s)	Pulse 1 to 2 Spacing (s)	Pulse 2 to 3 Spacing (s)	Start Location (s)
1	3	6M	66.1u	1.528m	1.373m	681.5m
2	1	12M	81.2u	-	-	831.9m
3	2	16M	78.0u	1.814m	-	141.7m
4	1	8M	87.5u	-	-	1.093
5	2	7M	69.1u	1.600m	-	646.8m
6	3	17M	50.9u	1.048m	1.004m	1.264
7	2	16M	82.7u	1.884m	-	272.5m
8	2	9M	68.2u	1.304m	-	924.3m
9	1	9M	86.5u	-	-	1.244

Long Pulse Radar Test Signal

Test Signal Name: LP_HT20_Signal_19

Number of Bursts in Trial: 17

Burst	Pulses per Burst	Chrip (Hz)	Pulse Width (s)	Pulse 1 to 2 Spacing (s)	Pulse 2 to 3 Spacing (s)	Start Location (s)
1	2	11M	81.2u	931.8u	-	3.965m
2	2	15M	85.3u	1.699m	-	250.7m
3	2	13M	92.7u	1.532m	-	77.91m
4	2	6M	92.9u	1.259m	-	533.1m
5	1	9M	88.3u	-	-	47.30m
6	2	7M	50.8u	1.170m	-	453.4m
7	3	19M	81.1u	1.873m	1.865m	511.2m
8	3	7M	78.5u	1.867m	1.143m	295.6m
9	2	7M	79.5u	1.664m	-	81.11m
10	2	10M	59.3u	1.021m	-	575.7m
11	1	15M	56.0u	-	-	667.1m
12	2	6M	70.6u	1.311m	-	448.3m
13	2	16M	65.2u	1.010m	-	263.1m
14	2	6M	67.5u	1.304m	-	278.1m
15	3	6M	57.5u	1.513m	1.822m	131.0m
16	2	15M	76.5u	1.902m	-	468.3m
17	1	7M	74.8u	-	-	436.2m



A D T

Long Pulse Radar Test Signal
Test Signal Name: LP_HT20_Signal_20
Number of Bursts in Trial: 19

Burst	Pulses per Burst	Chrip (Hz)	Pulse Width (s)	Pulse 1 to 2 Spacing (s)	Pulse 2 to 3 Spacing (s)	Start Location (s)
1	2	17M	78.7u	1.160m	-	310.1m
2	2	19M	88.1u	1.793m	-	543.3m
3	3	16M	70.6u	1.032m	1.586m	151.6m
4	1	7M	80.8u	-	-	33.13m
5	2	20M	68.2u	1.911m	-	261.1m
6	3	8M	75.9u	1.098m	1.620m	593.8m
7	2	16M	80.8u	963.2u	-	30.05m
8	2	14M	62.5u	1.638m	-	617.6m
9	2	16M	83.8u	1.003m	-	473.5m
10	1	10M	92.0u	-	-	466.1m
11	1	6M	80.5u	-	-	108.4m
12	2	13M	96.0u	1.495m	-	454.2m
13	1	9M	80.5u	-	-	91.80m
14	2	15M	93.0u	1.461m	-	556.6m
15	2	20M	81.9u	1.855m	-	59.29m
16	1	7M	93.4u	-	-	38.78m
17	3	10M	85.2u	1.470m	1.502m	500.4m
18	2	12M	68.9u	1.439m	-	23.59m
19	2	15M	96.3u	997.7u	-	28.69m

Long Pulse Radar Test Signal
Test Signal Name: LP_HT20_Signal_21
Number of Bursts in Trial: 9

Burst	Pulses per Burst	Chrip (Hz)	Pulse Width (s)	Pulse 1 to 2 Spacing (s)	Pulse 2 to 3 Spacing (s)	Start Location (s)
1	3	6M	89.1u	1.778m	1.055m	1.188
2	2	6M	76.4u	1.366m	-	73.27m
3	2	5M	79.1u	1.603m	-	1.007
4	2	18M	56.5u	1.236m	-	651.1m
5	1	6M	85.6u	-	-	256.3m
6	3	13M	52.3u	1.537m	1.387m	237.4m
7	2	10M	78.1u	947.9u	-	187.4m
8	1	17M	55.0u	-	-	475.7m
9	2	13M	74.6u	1.233m	-	693.8m



Long Pulse Radar Test Signal

Test Signal Name: LP_HT20_Signal_22

Number of Bursts in Trial: 19

Burst	Pulses per Burst	Chrip (Hz)	Pulse Width (s)	Pulse 1 to 2 Spacing (s)	Pulse 2 to 3 Spacing (s)	Start Location (s)
1	3	12M	61.8u	1.787m	1.381m	574.9m
2	2	17M	89.6u	1.083m	-	581.0m
3	3	15M	97.3u	954.7u	1.524m	108.7m
4	2	18M	50.6u	1.758m	-	543.0m
5	2	12M	68.7u	1.239m	-	333.7m
6	2	19M	95.6u	1.195m	-	131.7m
7	1	12M	66.3u	-	-	444.7m
8	1	19M	89.4u	-	-	139.3m
9	1	10M	50.2u	-	-	238.4m
10	2	18M	96.1u	1.826m	-	238.8m
11	1	19M	56.7u	-	-	215.9m
12	1	10M	81.7u	-	-	477.5m
13	1	9M	70.1u	-	-	123.7m
14	3	11M	64.7u	1.865m	1.348m	305.0m
15	1	16M	98.6u	-	-	305.5m
16	2	17M	87.9u	1.352m	-	366.3m
17	1	11M	52.3u	-	-	253.1m
18	3	17M	96.4u	1.465m	1.784m	303.3m
19	3	16M	77.3u	1.680m	1.295m	33.90m

Long Pulse Radar Test Signal

Test Signal Name: LP_HT20_Signal_23

Number of Bursts in Trial: 12

Burst	Pulses per Burst	Chrip (Hz)	Pulse Width (s)	Pulse 1 to 2 Spacing (s)	Pulse 2 to 3 Spacing (s)	Start Location (s)
1	3	12M	78.1u	1.176m	1.242m	528.5m
2	2	9M	79.4u	1.529m	-	394.6m
3	2	15M	77.2u	1.539m	-	659.4m
4	2	8M	61.8u	1.843m	-	468.8m
5	2	18M	86.1u	1.694m	-	153.6m
6	2	6M	92.5u	1.476m	-	847.8m
7	2	17M	60.4u	1.936m	-	336.3m
8	1	9M	90.8u	-	-	619.3m
9	2	18M	68.0u	1.004m	-	152.4m
10	2	9M	68.8u	1.722m	-	883.9m
11	3	18M	76.7u	1.583m	1.383m	697.2m
12	2	6M	65.6u	978.4u	-	324.4m



A D T

Long Pulse Radar Test Signal

Test Signal Name: LP_HT20_Signal_24

Number of Bursts in Trial: 14

Burst	Pulses per Burst	Chrip (Hz)	Pulse Width (s)	Pulse 1 to 2 Spacing (s)	Pulse 2 to 3 Spacing (s)	Start Location (s)
1	1	7M	85.3u	-	-	165.7m
2	1	11M	93.2u	-	-	407.0m
3	3	8M	92.2u	1.624m	1.640m	158.0m
4	2	12M	85.2u	1.429m	-	804.4m
5	2	7M	69.8u	1.483m	-	230.9m
6	2	12M	70.8u	1.246m	-	635.5m
7	2	13M	52.5u	1.448m	-	179.0m
8	2	16M	94.2u	1.224m	-	770.6m
9	2	6M	95.5u	1.792m	-	836.6m
10	3	8M	71.5u	1.852m	961.5u	336.4m
11	3	17M	68.2u	1.031m	1.741m	431.0m
12	2	20M	98.9u	1.744m	-	148.3m
13	3	8M	66.0u	1.717m	992.0u	322.1m
14	1	6M	83.9u	-	-	338.3m

Long Pulse Radar Test Signal

Test Signal Name: LP_HT20_Signal_25

Number of Bursts in Trial: 13

Burst	Pulses per Burst	Chrip (Hz)	Pulse Width (s)	Pulse 1 to 2 Spacing (s)	Pulse 2 to 3 Spacing (s)	Start Location (s)
1	2	9M	64.2u	1.245m	-	100.8m
2	3	9M	71.3u	1.046m	1.101m	779.2m
3	3	6M	50.8u	1.237m	1.000m	564.1m
4	1	8M	70.6u	-	-	136.2m
5	3	16M	98.7u	1.706m	1.613m	483.9m
6	1	14M	77.3u	-	-	325.5m
7	1	11M	93.1u	-	-	1.883m
8	1	10M	52.4u	-	-	363.8m
9	2	6M	85.6u	1.500m	-	479.8m
10	3	5M	67.7u	1.746m	1.316m	302.5m
11	2	15M	95.8u	1.348m	-	393.1m
12	3	12M	57.4u	993.6u	1.862m	872.9m
13	2	5M	87.9u	1.873m	-	554.9m



A D T

Long Pulse Radar Test Signal

Test Signal Name: LP_HT20_Signal_26

Number of Bursts in Trial: 15

Burst	Pulses per Burst	Chrip (Hz)	Pulse Width (s)	Pulse 1 to 2 Spacing (s)	Pulse 2 to 3 Spacing (s)	Start Location (s)
1	3	18M	73.2u	1.700m	1.696m	82.58m
2	2	16M	74.3u	1.744m	-	98.52m
3	2	13M	87.5u	1.707m	-	282.6m
4	1	10M	90.1u	-	-	495.3m
5	2	10M	88.0u	1.177m	-	40.54m
6	1	13M	67.6u	-	-	421.3m
7	2	19M	93.0u	1.367m	-	783.1m
8	3	10M	66.3u	1.775m	1.335m	132.2m
9	2	14M	57.9u	1.641m	-	782.4m
10	1	12M	56.4u	-	-	416.8m
11	2	13M	71.7u	1.300m	-	626.5m
12	2	15M	95.0u	1.573m	-	40.39m
13	1	7M	51.7u	-	-	444.6m
14	3	14M	57.5u	1.712m	1.064m	436.0m
15	3	10M	52.5u	1.002m	1.440m	617.1m

Long Pulse Radar Test Signal

Test Signal Name: LP_HT20_Signal_27

Number of Bursts in Trial: 20

Burst	Pulses per Burst	Chrip (Hz)	Pulse Width (s)	Pulse 1 to 2 Spacing (s)	Pulse 2 to 3 Spacing (s)	Start Location (s)
1	2	17M	54.7u	1.156m	-	414.0m
2	2	16M	78.7u	969.3u	-	56.56m
3	2	14M	86.9u	983.1u	-	52.82m
4	2	18M	75.9u	1.784m	-	230.1m
5	1	7M	72.8u	-	-	148.9m
6	3	18M	64.4u	1.089m	1.023m	335.7m
7	1	17M	56.6u	-	-	258.0m
8	2	13M	83.3u	1.328m	-	393.8m
9	2	18M	51.9u	1.464m	-	228.2m
10	2	17M	70.4u	1.025m	-	68.90m
11	2	14M	59.5u	1.935m	-	256.7m
12	3	15M	88.5u	1.387m	1.184m	397.6m
13	2	7M	52.1u	1.158m	-	533.5m
14	2	10M	82.7u	1.530m	-	27.77m
15	2	16M	55.2u	1.147m	-	436.8m
16	1	18M	68.8u	-	-	545.6m



A D T

17	1	14M	73.3u	-	-	86.09m
18	3	19M	55.2u	1.013m	1.480m	575.2m
19	2	16M	70.5u	1.853m	-	109.8m
20	1	10M	54.7u	-	-	393.2m

Long Pulse Radar Test Signal

Test Signal Name: LP_HT20_Signal_28

Number of Bursts in Trial: 9

Burst	Pulses per Burst	Chrip (Hz)	Pulse Width (s)	Pulse 1 to 2 Spacing (s)	Pulse 2 to 3 Spacing (s)	Start Location (s)
1	2	8M	93.0u	1.573m	-	1.227
2	2	12M	65.4u	1.389m	-	731.3m
3	3	6M	87.4u	1.450m	1.601m	645.7m
4	1	8M	97.0u	-	-	463.1m
5	2	11M	96.8u	946.2u	-	689.1m
6	2	6M	67.9u	1.685m	-	497.7m
7	2	13M	76.7u	1.865m	-	522.3m
8	2	7M	78.1u	1.098m	-	328.4m
9	2	12M	78.0u	1.637m	-	1.297

Long Pulse Radar Test Signal

Test Signal Name: LP_HT20_Signal_29

Number of Bursts in Trial: 12

Burst	Pulses per Burst	Chrip (Hz)	Pulse Width (s)	Pulse 1 to 2 Spacing (s)	Pulse 2 to 3 Spacing (s)	Start Location (s)
1	2	15M	66.7u	1.340m	-	122.1m
2	1	19M	63.9u	-	-	109.8m
3	2	8M	61.3u	942.7u	-	372.4m
4	1	10M	52.9u	-	-	433.0m
5	1	12M	90.7u	-	-	839.2m
6	2	6M	89.8u	1.542m	-	541.8m
7	1	18M	96.1u	-	-	156.5m
8	1	6M	59.7u	-	-	66.44m
9	2	18M	91.6u	1.114m	-	315.3m
10	2	11M	94.1u	1.033m	-	339.4m
11	3	8M	92.9u	1.021m	1.059m	8.797m
12	2	9M	73.2u	1.824m	-	672.3m



Long Pulse Radar Test Signal

Test Signal Name: LP_HT20_Signal_30

Number of Bursts in Trial: 14

Burst	Pulses per Burst	Chrip (Hz)	Pulse Width (s)	Pulse 1 to 2 Spacing (s)	Pulse 2 to 3 Spacing (s)	Start Location (s)
1	2	11M	66.9u	1.930m	-	648.3m
2	2	12M	66.3u	1.356m	-	55.89m
3	1	13M	77.4u	-	-	33.01m
4	2	8M	68.5u	1.695m	-	268.6m
5	3	20M	94.0u	1.700m	1.040m	381.4m
6	1	15M	57.7u	-	-	537.8m
7	2	8M	58.3u	1.771m	-	66.43m
8	2	16M	66.2u	1.495m	-	178.1m
9	2	9M	98.7u	976.3u	-	563.0m
10	1	15M	76.2u	-	-	453.6m
11	1	18M	84.6u	-	-	31.54m
12	2	9M	62.1u	1.136m	-	393.9m
13	2	11M	90.9u	971.1u	-	487.2m
14	2	5M	56.2u	1.799m	-	803.7m

Long Pulse Radar Test Signal

Test Signal Name: LP_HT40_Signal_01

Number of Bursts in Trial: 18

Burst	Pulses per Burst	Chrip (Hz)	Pulse Width (s)	Pulse 1 to 2 Spacing (s)	Pulse 2 to 3 Spacing (s)	Start Location (s)
1	1	12M	92.5u	-	-	181.2m
2	3	15M	61.8u	1.833m	1.889m	592.4m
3	2	16M	57.9u	1.514m	-	54.45m
4	3	18M	89.1u	1.383m	1.112m	94.05m
5	2	13M	100.0u	1.071m	-	24.91m
6	3	16M	99.5u	1.169m	964.5u	447.2m
7	3	15M	100.0u	1.088m	914.0u	426.9m
8	1	15M	63.2u	-	-	185.5m
9	3	17M	91.4u	1.633m	1.793m	368.6m
10	3	13M	58.1u	1.673m	1.528m	646.3m
11	1	8M	52.9u	-	-	550.6m
12	1	17M	67.3u	-	-	590.5m
13	2	10M	63.5u	1.272m	-	9.768m
14	3	17M	66.5u	1.147m	1.513m	239.4m
15	1	19M	70.0u	-	-	315.5m
16	1	6M	59.6u	-	-	49.02m
17	1	14M	64.6u	-	-	459.1m
18	2	8M	70.3u	1.640m	-	254.1m



A D T

Long Pulse Radar Test Signal

Test Signal Name: LP_HT40_Signal_02

Number of Bursts in Trial: 15

Burst	Pulses per Burst	Chrip (Hz)	Pulse Width (s)	Pulse 1 to 2 Spacing (s)	Pulse 2 to 3 Spacing (s)	Start Location (s)
1	2	15M	50.9u	1.845m	-	752.9m
2	2	18M	70.0u	984.0u	-	746.8m
3	2	13M	81.5u	1.485m	-	553.0m
4	2	6M	89.0u	1.860m	-	520.4m
5	1	9M	97.5u	-	-	372.7m
6	2	17M	86.1u	1.845m	-	191.0m
7	2	15M	72.7u	1.378m	-	671.0m
8	1	7M	62.5u	-	-	259.6m
9	3	14M	73.4u	1.305m	1.036m	462.6m
10	2	12M	62.4u	1.408m	-	304.4m
11	3	17M	88.0u	1.256m	1.799m	600.8m
12	2	20M	88.9u	1.029m	-	145.8m
13	1	10M	62.6u	-	-	331.0m
14	2	11M	79.3u	1.868m	-	673.1m
15	1	18M	64.5u	-	-	32.45m

Long Pulse Radar Test Signal

Test Signal Name: LP_HT40_Signal_03

Number of Bursts in Trial: 16

Burst	Pulses per Burst	Chrip (Hz)	Pulse Width (s)	Pulse 1 to 2 Spacing (s)	Pulse 2 to 3 Spacing (s)	Start Location (s)
1	3	14M	69.1u	1.801m	1.885m	35.35m
2	3	13M	85.7u	1.025m	991.3u	622.1m
3	1	18M	89.9u	-	-	445.9m
4	1	6M	68.1u	-	-	217.8m
5	2	20M	97.0u	1.188m	-	527.8m
6	3	12M	65.5u	1.406m	1.816m	551.0m
7	2	15M	63.5u	1.731m	-	137.1m
8	2	6M	63.6u	1.259m	-	392.0u
9	2	19M	59.8u	1.771m	-	169.0m
10	2	19M	52.6u	1.472m	-	584.8m
11	1	6M	64.0u	-	-	303.0m
12	2	16M	50.1u	1.067m	-	486.2m
13	2	9M	74.8u	1.057m	-	238.1m
14	2	11M	75.3u	1.547m	-	543.4m
15	2	10M	50.0u	1.294m	-	294.1m
16	3	15M	79.7u	1.898m	1.238m	33.04m



Long Pulse Radar Test Signal

Test Signal Name: LP_HT40_Signal_04

Number of Bursts in Trial: 19

Burst	Pulses per Burst	Chrip (Hz)	Pulse Width (s)	Pulse 1 to 2 Spacing (s)	Pulse 2 to 3 Spacing (s)	Start Location (s)
1	3	13M	63.8u	1.569m	1.576m	388.8m
2	3	19M	68.9u	1.491m	1.367m	427.1m
3	2	7M	63.0u	1.196m	-	43.84m
4	2	8M	64.2u	1.788m	-	575.6m
5	2	19M	93.0u	1.576m	-	266.6m
6	1	8M	91.2u	-	-	623.7m
7	2	17M	88.6u	1.609m	-	173.7m
8	1	13M	75.1u	-	-	304.1m
9	3	20M	65.6u	1.272m	1.627m	452.9m
10	2	15M	78.5u	1.749m	-	395.5m
11	3	16M	73.6u	1.054m	1.027m	248.7m
12	1	13M	72.5u	-	-	209.9m
13	1	12M	73.8u	-	-	249.1m
14	1	13M	95.5u	-	-	73.73m
15	2	14M	76.6u	1.914m	-	427.7m
16	3	16M	81.2u	1.452m	1.370m	622.7m
17	2	15M	75.6u	1.055m	-	517.5m
18	1	9M	92.9u	-	-	211.0m
19	2	7M	66.3u	1.298m	-	477.6m

Long Pulse Radar Test Signal

Test Signal Name: LP_HT40_Signal_05

Number of Bursts in Trial: 17

Burst	Pulses per Burst	Chrip (Hz)	Pulse Width (s)	Pulse 1 to 2 Spacing (s)	Pulse 2 to 3 Spacing (s)	Start Location (s)
1	1	13M	78.5u	-	-	481.7m
2	3	15M	61.0u	1.470m	1.524m	24.13m
3	2	13M	78.0u	1.678m	-	437.0m
4	2	16M	88.5u	1.334m	-	357.4m
5	2	8M	75.0u	1.560m	-	108.0m
6	2	9M	80.7u	1.211m	-	204.9m
7	3	6M	61.4u	1.565m	1.155m	591.6m
8	3	7M	89.1u	1.095m	1.126m	443.2m
9	1	19M	96.1u	-	-	35.55m
10	2	20M	96.7u	1.838m	-	298.8m
11	2	12M	60.3u	1.472m	-	16.68m
12	3	8M	81.4u	1.733m	941.6u	621.1m



A D T

13	3	14M	62.3u	1.095m	1.455m	477.5m
14	2	10M	53.4u	1.818m	-	244.4m
15	1	19M	96.8u	-	-	415.4m
16	1	11M	63.5u	-	-	609.7m
17	2	7M	60.0u	1.402m	-	490.9m

Long Pulse Radar Test Signal

Test Signal Name: LP_HT40_Signal_06

Number of Bursts in Trial: 18

Burst	Pulses per Burst	Chrip (Hz)	Pulse Width (s)	Pulse 1 to 2 Spacing (s)	Pulse 2 to 3 Spacing (s)	Start Location (s)
1	3	6M	62.6u	942.4u	1.231m	41.02m
2	2	18M	56.6u	1.586m	-	492.1m
3	2	16M	99.8u	1.883m	-	654.3m
4	2	18M	62.9u	1.439m	-	550.5m
5	2	11M	99.6u	1.379m	-	623.2m
6	2	7M	83.1u	1.271m	-	366.8m
7	2	19M	51.2u	1.442m	-	44.31m
8	3	9M	64.8u	1.122m	1.053m	332.0m
9	2	11M	82.4u	1.044m	-	300.8m
10	3	12M	93.9u	939.1u	1.830m	78.30m
11	1	7M	61.2u	-	-	182.0m
12	1	15M	80.2u	-	-	36.97m
13	2	15M	69.6u	1.288m	-	23.20m
14	3	8M	56.6u	1.326m	1.130m	65.06m
15	2	14M	68.8u	1.564m	-	639.8m
16	1	10M	97.7u	-	-	660.4m
17	3	15M	66.3u	1.879m	1.052m	88.38m
18	1	8M	57.7u	-	-	273.7m

Long Pulse Radar Test Signal

Test Signal Name: LP_HT40_Signal_07

Number of Bursts in Trial: 12

Burst	Pulses per Burst	Chrip (Hz)	Pulse Width (s)	Pulse 1 to 2 Spacing (s)	Pulse 2 to 3 Spacing (s)	Start Location (s)
1	1	11M	70.8u	-	-	150.5m
2	3	6M	82.5u	1.070m	1.841m	100.7m
3	3	7M	69.0u	983.0u	1.027m	468.1m
4	1	14M	54.0u	-	-	370.1m
5	2	8M	70.8u	1.928m	-	585.6m
6	2	7M	81.6u	1.231m	-	653.3m
7	1	16M	66.1u	-	-	899.4m
8	2	19M	91.7u	1.563m	-	752.7m



A D T

9	3	9M	65.8u	1.482m	1.239m	748.9m
10	2	16M	68.8u	1.253m	-	519.3m
11	1	15M	65.4u	-	-	256.6m
12	1	18M	76.1u	-	-	921.9m

Long Pulse Radar Test Signal

Test Signal Name: LP_HT40_Signal_08

Number of Bursts in Trial: 9

Burst	Pulses per Burst	Chrip (Hz)	Pulse Width (s)	Pulse 1 to 2 Spacing (s)	Pulse 2 to 3 Spacing (s)	Start Location (s)
1	1	15M	74.9u	-	-	847.6m
2	2	14M	60.6u	1.496m	-	1.188
3	2	17M	98.0u	1.701m	-	806.9m
4	1	10M	92.2u	-	-	909.7m
5	1	17M	82.6u	-	-	329.4m
6	2	10M	77.1u	1.820m	-	976.8m
7	2	13M	85.0u	1.288m	-	172.2m
8	2	13M	62.3u	1.725m	-	854.7m
9	2	6M	68.3u	1.756m	-	1.308

Long Pulse Radar Test Signal

Test Signal Name: LP_HT40_Signal_09

Number of Bursts in Trial: 14

Burst	Pulses per Burst	Chrip (Hz)	Pulse Width (s)	Pulse 1 to 2 Spacing (s)	Pulse 2 to 3 Spacing (s)	Start Location (s)
1	2	19M	56.3u	1.643m	-	432.9m
2	2	16M	94.8u	1.401m	-	810.8m
3	2	19M	90.9u	932.1u	-	274.1m
4	1	14M	69.7u	-	-	350.2m
5	2	18M	58.9u	1.703m	-	648.0m
6	2	10M	89.5u	935.5u	-	394.3m
7	2	13M	78.9u	1.807m	-	731.8m
8	3	9M	76.4u	1.301m	1.417m	64.89m
9	2	13M	85.5u	1.861m	-	194.4m
10	2	7M	88.0u	1.235m	-	277.5m
11	2	11M	73.5u	1.414m	-	177.3m
12	1	17M	87.2u	-	-	304.3m
13	2	6M	92.9u	1.497m	-	724.5m
14	2	12M	63.0u	1.616m	-	637.1m



Long Pulse Radar Test Signal

Test Signal Name: LP_HT40_Signal_10

Number of Bursts in Trial: 18

Burst	Pulses per Burst	Chrip (Hz)	Pulse Width (s)	Pulse 1 to 2 Spacing (s)	Pulse 2 to 3 Spacing (s)	Start Location (s)
1	2	17M	83.8u	1.652m	-	106.7m
2	3	14M	97.9u	1.707m	1.861m	216.0m
3	1	19M	56.4u	-	-	67.09m
4	2	8M	85.6u	1.141m	-	624.0m
5	2	9M	78.7u	1.514m	-	357.2m
6	1	17M	61.2u	-	-	416.2m
7	3	7M	79.9u	1.142m	1.464m	654.7m
8	2	12M	55.9u	1.431m	-	602.2m
9	3	13M	55.8u	1.124m	1.825m	531.4m
10	2	7M	51.0u	1.639m	-	218.8m
11	3	7M	57.0u	1.433m	1.383m	365.7m
12	2	15M	83.2u	1.255m	-	215.0m
13	3	19M	55.9u	1.266m	1.705m	576.6m
14	2	17M	96.3u	1.287m	-	417.1m
15	3	5M	51.5u	1.659m	1.462m	516.2m
16	2	16M	76.0u	1.873m	-	209.1m
17	2	7M	69.7u	1.378m	-	369.0m
18	2	10M	87.7u	1.612m	-	545.1m

Long Pulse Radar Test Signal

Test Signal Name: LP_HT40_Signal_11

Number of Bursts in Trial: 13

Burst	Pulses per Burst	Chrip (Hz)	Pulse Width (s)	Pulse 1 to 2 Spacing (s)	Pulse 2 to 3 Spacing (s)	Start Location (s)
1	2	7M	77.3u	1.323m	-	28.84m
2	2	9M	82.9u	1.859m	-	474.0m
3	2	17M	63.4u	1.873m	-	390.9m
4	3	7M	99.3u	1.369m	970.7u	656.7m
5	2	16M	56.3u	1.685m	-	486.6m
6	2	8M	65.7u	1.498m	-	864.4m
7	2	6M	72.0u	980.0u	-	351.7m
8	2	12M	57.0u	1.377m	-	769.1m
9	3	17M	62.1u	1.299m	1.727m	705.0m
10	1	16M	92.4u	-	-	852.0m
11	2	12M	52.8u	1.351m	-	286.4m
12	2	11M	71.1u	1.025m	-	530.4m
13	2	16M	55.3u	1.868m	-	558.6m



A D T

Long Pulse Radar Test Signal

Test Signal Name: LP_HT40_Signal_12

Number of Bursts in Trial: 11

Burst	Pulses per Burst	Chrip (Hz)	Pulse Width (s)	Pulse 1 to 2 Spacing (s)	Pulse 2 to 3 Spacing (s)	Start Location (s)
1	2	19M	74.1u	1.115m	-	37.10m
2	1	14M	82.5u	-	-	789.7m
3	2	11M	66.4u	1.892m	-	622.3m
4	2	15M	96.8u	1.187m	-	668.0m
5	3	8M	93.8u	1.124m	1.416m	357.0m
6	3	13M	63.0u	1.837m	1.421m	793.8m
7	2	18M	77.2u	1.344m	-	656.5m
8	1	11M	87.4u	-	-	981.9m
9	1	12M	87.3u	-	-	807.2m
10	2	17M	76.6u	1.222m	-	732.6m
11	3	19M	88.3u	1.350m	1.906m	737.7m

Long Pulse Radar Test Signal

Test Signal Name: LP_HT40_Signal_13

Number of Bursts in Trial: 19

Burst	Pulses per Burst	Chrip (Hz)	Pulse Width (s)	Pulse 1 to 2 Spacing (s)	Pulse 2 to 3 Spacing (s)	Start Location (s)
1	1	14M	90.0u	-	-	626.3m
2	3	16M	52.7u	1.625m	1.071m	371.9m
3	2	7M	65.2u	1.139m	-	43.30m
4	2	15M	79.4u	1.491m	-	430.5m
5	2	9M	85.0u	1.801m	-	598.0m
6	2	17M	58.5u	1.920m	-	377.7m
7	1	20M	96.4u	-	-	368.2m
8	3	7M	97.9u	1.335m	1.390m	468.9m
9	1	5M	57.7u	-	-	300.3m
10	2	8M	88.7u	1.251m	-	430.0m
11	2	14M	75.7u	1.489m	-	505.9m
12	2	5M	97.1u	943.9u	-	607.1m
13	2	9M	72.4u	928.6u	-	4.126m
14	2	18M	93.3u	1.230m	-	406.9m
15	3	14M	68.6u	1.354m	1.293m	578.2m
16	3	5M	71.7u	1.206m	957.3u	426.3m
17	3	19M	57.8u	1.199m	1.465m	217.5m
18	2	6M	72.1u	1.720m	-	434.5m
19	2	10M	61.5u	1.594m	-	82.42m



A D T

Long Pulse Radar Test Signal

Test Signal Name: LP_HT40_Signal_14

Number of Bursts in Trial: 8

Burst	Pulses per Burst	Chrip (Hz)	Pulse Width (s)	Pulse 1 to 2 Spacing (s)	Pulse 2 to 3 Spacing (s)	Start Location (s)
1	1	12M	69.0u	-	-	1.413
2	2	13M	91.5u	1.264m	-	948.3m
3	1	15M	54.9u	-	-	118.0m
4	3	16M	65.5u	1.524m	1.298m	1.050
5	2	16M	64.9u	1.632m	-	1.142
6	1	7M	88.0u	-	-	933.1m
7	2	10M	79.7u	1.867m	-	30.65m
8	3	9M	88.4u	1.199m	1.388m	603.2m

Long Pulse Radar Test Signal

Test Signal Name: LP_HT40_Signal_15

Number of Bursts in Trial: 15

Burst	Pulses per Burst	Chrip (Hz)	Pulse Width (s)	Pulse 1 to 2 Spacing (s)	Pulse 2 to 3 Spacing (s)	Start Location (s)
1	2	14M	68.2u	1.538m	-	64.00m
2	2	12M	63.2u	1.658m	-	65.30m
3	2	10M	59.4u	1.900m	-	664.8m
4	2	10M	95.4u	1.904m	-	713.8m
5	1	13M	72.1u	-	-	158.6m
6	3	13M	90.7u	1.644m	1.239m	738.2m
7	2	16M	75.0u	1.028m	-	717.7m
8	2	10M	60.2u	1.728m	-	750.0m
9	3	11M	81.4u	1.579m	1.442m	61.22m
10	1	6M	64.7u	-	-	368.0m
11	1	14M	92.7u	-	-	60.51m
12	3	9M	64.1u	1.418m	1.049m	57.55m
13	1	6M	62.4u	-	-	140.3m
14	2	17M	63.7u	1.606m	-	268.5m
15	1	20M	72.6u	-	-	303.9m

Long Pulse Radar Test Signal

Test Signal Name: LP_HT40_Signal_16

Number of Bursts in Trial: 9

Burst	Pulses per Burst	Chrip (Hz)	Pulse Width (s)	Pulse 1 to 2 Spacing (s)	Pulse 2 to 3 Spacing (s)	Start Location (s)
1	2	6M	56.1u	1.082m	-	641.1m
2	3	18M	84.5u	1.678m	1.404m	1.328



A D T

3	1	10M	74.9u	-	-	295.4m
4	2	15M	52.7u	1.810m	-	1.137
5	2	8M	50.7u	1.712m	-	198.2m
6	3	15M	89.0u	1.529m	1.675m	314.7m
7	3	6M	69.4u	1.713m	1.765m	876.8m
8	2	6M	96.9u	1.313m	-	1.032
9	3	16M	85.8u	1.148m	1.285m	746.7m

Long Pulse Radar Test Signal

Test Signal Name: LP_HT40_Signal_17

Number of Bursts in Trial: 18

Burst	Pulses per Burst	Chrip (Hz)	Pulse Width (s)	Pulse 1 to 2 Spacing (s)	Pulse 2 to 3 Spacing (s)	Start Location (s)
1	2	15M	64.7u	1.617m	-	556.1m
2	1	11M	94.5u	-	-	319.4m
3	3	15M	66.2u	1.550m	990.8u	380.5m
4	1	19M	71.6u	-	-	656.3m
5	1	19M	88.1u	-	-	430.6m
6	2	18M	69.5u	1.786m	-	380.9m
7	2	15M	51.0u	1.080m	-	274.2m
8	2	18M	68.7u	1.565m	-	8.002m
9	2	11M	88.2u	1.457m	-	557.0m
10	2	8M	81.7u	1.477m	-	138.0u
11	1	19M	60.8u	-	-	549.6m
12	1	6M	72.7u	-	-	197.6m
13	2	19M	78.7u	1.474m	-	156.8m
14	2	20M	76.9u	1.432m	-	270.7m
15	1	19M	59.8u	-	-	165.7m
16	1	11M	85.3u	-	-	384.6m
17	2	13M	98.1u	1.719m	-	279.2m
18	2	6M	50.9u	1.427m	-	363.0m

Long Pulse Radar Test Signal

Test Signal Name: LP_HT40_Signal_18

Number of Bursts in Trial: 10

Burst	Pulses per Burst	Chrip (Hz)	Pulse Width (s)	Pulse 1 to 2 Spacing (s)	Pulse 2 to 3 Spacing (s)	Start Location (s)
1	3	16M	50.6u	1.928m	1.192m	668.3m
2	1	13M	90.4u	-	-	355.2m
3	2	16M	83.7u	997.3u	-	1.022
4	2	9M	70.8u	1.489m	-	335.6m
5	2	13M	51.1u	1.212m	-	739.2m
6	2	19M	74.4u	1.327m	-	653.4m



A D T

7	2	17M	72.5u	1.370m	-	1.008
8	2	18M	98.3u	1.809m	-	356.1m
9	1	11M	63.0u	-	-	932.0m
10	3	7M	57.8u	1.165m	1.653m	965.3m

Long Pulse Radar Test Signal

Test Signal Name: LP_HT40_Signal_19

Number of Bursts in Trial: 17

Burst	Pulses per Burst	Chrip (Hz)	Pulse Width (s)	Pulse 1 to 2 Spacing (s)	Pulse 2 to 3 Spacing (s)	Start Location (s)
1	1	10M	88.1u	-	-	278.4m
2	2	14M	57.2u	952.8u	-	419.0m
3	3	9M	78.1u	1.233m	988.9u	156.1m
4	2	17M	68.5u	1.123m	-	170.0m
5	2	15M	72.9u	1.138m	-	475.1m
6	2	13M	59.4u	1.497m	-	653.8m
7	3	20M	68.3u	1.501m	1.094m	432.9m
8	2	11M	70.6u	1.723m	-	518.7m
9	1	10M	55.5u	-	-	575.2m
10	3	12M	57.7u	1.567m	954.3u	151.9m
11	2	11M	86.6u	1.520m	-	285.0m
12	2	13M	73.3u	1.172m	-	311.7m
13	2	10M	72.9u	1.707m	-	288.4m
14	2	12M	95.6u	1.058m	-	388.7m
15	1	9M	78.6u	-	-	563.5m
16	3	18M	83.8u	1.602m	1.058m	373.8m
17	2	5M	64.1u	1.717m	-	413.2m

Long Pulse Radar Test Signal

Test Signal Name: LP_HT40_Signal_20

Number of Bursts in Trial: 16

Burst	Pulses per Burst	Chrip (Hz)	Pulse Width (s)	Pulse 1 to 2 Spacing (s)	Pulse 2 to 3 Spacing (s)	Start Location (s)
1	3	11M	58.8u	1.696m	1.879m	145.8m
2	2	9M	59.5u	1.422m	-	158.4m
3	1	5M	54.6u	-	-	271.7m
4	2	8M	80.4u	1.546m	-	99.47m
5	2	10M	67.2u	1.094m	-	93.65m
6	1	13M	79.3u	-	-	313.6m
7	2	18M	67.7u	1.290m	-	559.0m
8	2	10M	70.0u	1.316m	-	106.4m
9	3	11M	78.2u	1.720m	1.038m	690.5m
10	1	9M	93.4u	-	-	125.2m



A D T

11	2	13M	85.9u	1.570m	-	679.2m
12	2	16M	75.0u	930.0u	-	428.7m
13	3	7M	67.1u	1.117m	1.220m	24.56m
14	2	8M	52.2u	1.295m	-	398.7m
15	2	16M	70.4u	1.063m	-	453.8m
16	2	9M	60.6u	1.221m	-	255.1m

Long Pulse Radar Test Signal

Test Signal Name: LP_HT40_Signal_21

Number of Bursts in Trial: 11

Burst	Pulses per Burst	Chrip (Hz)	Pulse Width (s)	Pulse 1 to 2 Spacing (s)	Pulse 2 to 3 Spacing (s)	Start Location (s)
1	3	16M	78.4u	1.095m	1.436m	784.6m
2	3	10M	69.7u	1.815m	1.412m	521.8m
3	1	19M	66.8u	-	-	901.3m
4	1	9M	88.2u	-	-	11.32m
5	3	13M	82.5u	1.521m	1.609m	968.7m
6	2	8M	98.1u	1.359m	-	614.8m
7	2	19M	87.1u	1.197m	-	631.4m
8	2	13M	95.3u	1.708m	-	885.1m
9	2	7M	78.4u	1.134m	-	74.04m
10	2	15M	77.9u	1.293m	-	149.8m
11	1	17M	73.3u	-	-	237.8m

Long Pulse Radar Test Signal

Test Signal Name: LP_HT40_Signal_22

Number of Bursts in Trial: 13

Burst	Pulses per Burst	Chrip (Hz)	Pulse Width (s)	Pulse 1 to 2 Spacing (s)	Pulse 2 to 3 Spacing (s)	Start Location (s)
1	2	19M	57.2u	1.369m	-	306.2m
2	2	19M	61.7u	1.648m	-	415.9m
3	2	18M	59.4u	1.139m	-	615.1m
4	2	13M	75.7u	1.733m	-	288.1m
5	2	9M	80.9u	949.1u	-	758.9m
6	2	15M	90.5u	1.399m	-	181.8m
7	3	17M	73.5u	1.651m	1.712m	674.6m
8	1	9M	63.3u	-	-	468.0m
9	1	11M	57.5u	-	-	354.7m
10	3	11M	76.8u	1.354m	1.192m	228.9m
11	3	11M	62.8u	1.284m	1.242m	34.43m
12	2	6M	63.8u	1.130m	-	493.6m
13	2	18M	80.3u	1.619m	-	149.7m



A D T

Long Pulse Radar Test Signal

Test Signal Name: LP_HT40_Signal_23

Number of Bursts in Trial: 9

Burst	Pulses per Burst	Chrip (Hz)	Pulse Width (s)	Pulse 1 to 2 Spacing (s)	Pulse 2 to 3 Spacing (s)	Start Location (s)
1	2	11M	65.0u	1.156m	-	164.8m
2	1	8M	62.2u	-	-	22.47m
3	1	15M	82.3u	-	-	231.4m
4	3	7M	97.5u	1.022m	1.560m	293.0m
5	3	9M	50.6u	1.091m	963.4u	242.8m
6	1	8M	54.9u	-	-	429.2m
7	2	12M	58.7u	1.529m	-	1.025
8	2	11M	97.4u	1.139m	-	1.237
9	3	13M	78.8u	1.466m	1.357m	1.205

Long Pulse Radar Test Signal

Test Signal Name: LP_HT40_Signal_24

Number of Bursts in Trial: 10

Burst	Pulses per Burst	Chrip (Hz)	Pulse Width (s)	Pulse 1 to 2 Spacing (s)	Pulse 2 to 3 Spacing (s)	Start Location (s)
1	2	18M	79.0u	1.815m	-	1.173
2	3	13M	65.1u	1.916m	1.470m	558.5m
3	2	19M	50.1u	1.513m	-	507.4m
4	2	15M	70.1u	981.9u	-	392.7m
5	1	9M	70.1u	-	-	584.7m
6	3	19M	81.3u	1.162m	1.334m	76.20m
7	2	16M	94.7u	1.775m	-	655.8m
8	2	19M	59.7u	1.242m	-	187.6m
9	2	16M	94.0u	1.081m	-	942.1m
10	3	10M	71.8u	1.382m	1.538m	484.6m

Long Pulse Radar Test Signal

Test Signal Name: LP_HT40_Signal_25

Number of Bursts in Trial: 18

Burst	Pulses per Burst	Chrip (Hz)	Pulse Width (s)	Pulse 1 to 2 Spacing (s)	Pulse 2 to 3 Spacing (s)	Start Location (s)
1	3	10M	89.4u	1.280m	937.6u	253.5m
2	1	6M	60.4u	-	-	661.7m
3	2	10M	85.4u	1.427m	-	397.7m
4	3	15M	83.0u	1.453m	1.231m	33.56m
5	3	13M	50.6u	1.112m	1.290m	262.1m
6	3	13M	54.6u	1.397m	1.069m	309.8m



A D T

7	2	16M	75.2u	1.058m	-	53.30m
8	1	6M	98.2u	-	-	352.8m
9	1	10M	70.1u	-	-	512.9m
10	3	17M	84.3u	1.277m	1.392m	379.2m
11	2	7M	62.5u	1.759m	-	136.3m
12	2	13M	90.9u	1.106m	-	165.9m
13	1	9M	93.5u	-	-	138.8m
14	2	12M	82.0u	1.839m	-	43.11m
15	1	11M	64.7u	-	-	274.5m
16	2	14M	90.6u	1.320m	-	54.45m
17	1	16M	95.0u	-	-	402.2m
18	2	14M	87.8u	1.450m	-	547.5m

Long Pulse Radar Test Signal

Test Signal Name: LP_HT40_Signal_26

Number of Bursts in Trial: 9

Burst	Pulses per Burst	Chrip (Hz)	Pulse Width (s)	Pulse 1 to 2 Spacing (s)	Pulse 2 to 3 Spacing (s)	Start Location (s)
1	1	6M	85.4u	-	-	1.081
2	3	9M	62.3u	1.603m	1.142m	531.8m
3	2	20M	57.7u	1.702m	-	447.6m
4	3	11M	76.7u	1.497m	1.728m	925.9m
5	2	11M	58.4u	1.782m	-	435.1m
6	3	14M	56.7u	1.017m	1.014m	30.61m
7	3	15M	65.7u	1.191m	1.174m	50.81m
8	1	6M	74.5u	-	-	1.124
9	2	6M	95.2u	1.375m	-	883.8m

Long Pulse Radar Test Signal

Test Signal Name: LP_HT40_Signal_27

Number of Bursts in Trial: 19

Burst	Pulses per Burst	Chrip (Hz)	Pulse Width (s)	Pulse 1 to 2 Spacing (s)	Pulse 2 to 3 Spacing (s)	Start Location (s)
1	3	20M	97.8u	934.2u	1.048m	172.3m
2	3	11M	64.8u	987.2u	1.062m	590.4m
3	1	11M	67.5u	-	-	360.9m
4	3	18M	81.9u	1.408m	1.223m	154.6m
5	1	15M	70.7u	-	-	218.6m
6	3	15M	92.5u	1.223m	1.429m	232.9m
7	3	13M	74.6u	1.710m	1.882m	181.4m
8	2	10M	96.1u	1.089m	-	495.7m
9	1	13M	55.1u	-	-	557.5m
10	1	10M	62.8u	-	-	78.61m



A D T

11	2	10M	54.6u	1.101m	-	332.6m
12	2	13M	74.5u	1.798m	-	456.3m
13	2	19M	58.9u	1.742m	-	433.2m
14	2	11M	67.5u	1.133m	-	290.1m
15	3	13M	74.2u	1.417m	1.843m	397.9m
16	3	15M	95.7u	1.416m	1.568m	49.43m
17	2	9M	76.1u	1.285m	-	546.9m
18	2	11M	53.1u	1.069m	-	192.6m
19	3	12M	60.4u	1.397m	1.238m	452.4m

Long Pulse Radar Test Signal

Test Signal Name: LP_HT40_Signal_28

Number of Bursts in Trial: 8

Burst	Pulses per Burst	Chrip (Hz)	Pulse Width (s)	Pulse 1 to 2 Spacing (s)	Pulse 2 to 3 Spacing (s)	Start Location (s)
1	1	17M	97.5u	-	-	283.2m
2	1	7M	76.1u	-	-	1.412
3	3	7M	70.1u	1.487m	968.9u	997.8m
4	2	5M	82.2u	1.133m	-	642.8m
5	3	13M	93.8u	1.673m	1.891m	1.459
6	1	18M	56.7u	-	-	1.475
7	3	11M	58.6u	1.562m	1.918m	945.5m
8	1	13M	95.1u	-	-	1.120

Long Pulse Radar Test Signal

Test Signal Name: LP_HT40_Signal_29

Number of Bursts in Trial: 16

Burst	Pulses per Burst	Chrip (Hz)	Pulse Width (s)	Pulse 1 to 2 Spacing (s)	Pulse 2 to 3 Spacing (s)	Start Location (s)
1	2	12M	65.4u	1.342m	-	422.1m
2	2	7M	53.8u	1.900m	-	528.4m
3	2	9M	82.5u	1.691m	-	181.7m
4	2	9M	85.3u	1.903m	-	3.318m
5	1	13M	67.7u	-	-	504.1m
6	2	18M	92.3u	1.289m	-	656.2m
7	3	9M	99.8u	1.367m	1.814m	551.7m
8	1	19M	68.2u	-	-	38.20m
9	3	16M	70.7u	1.927m	938.3u	206.7m
10	2	7M	87.5u	1.754m	-	692.4m
11	2	20M	98.6u	1.071m	-	728.4m
12	1	11M	60.1u	-	-	540.0m
13	3	7M	94.1u	1.473m	1.675m	346.0m
14	2	10M	53.8u	1.882m	-	737.3m



A D T

15	3	6M	78.1u	987.9u	1.755m	224.3m
16	3	7M	72.0u	1.108m	1.326m	432.9m

Long Pulse Radar Test Signal

Test Signal Name: LP_HT40_Signal_30

Number of Bursts in Trial: 19

Burst	Pulses per Burst	Chrip (Hz)	Pulse Width (s)	Pulse 1 to 2 Spacing (s)	Pulse 2 to 3 Spacing (s)	Start Location (s)
1	1	11M	64.5u	-	-	320.5m
2	2	19M	92.1u	1.208m	-	12.86m
3	1	15M	68.3u	-	-	137.2m
4	2	19M	59.2u	1.631m	-	294.7m
5	3	8M	73.9u	1.254m	1.231m	468.8m
6	2	9M	56.4u	1.537m	-	377.1m
7	3	10M	91.8u	1.568m	1.249m	517.1m
8	3	8M	61.1u	1.568m	1.858m	284.3m
9	1	16M	97.9u	-	-	254.5m
10	2	20M	58.0u	1.639m	-	177.2m
11	2	18M	78.9u	1.012m	-	628.1m
12	2	19M	81.7u	1.399m	-	325.3m
13	2	13M	82.6u	1.122m	-	45.61m
14	2	18M	50.4u	1.389m	-	31.52m
15	2	7M	92.8u	1.757m	-	625.6m
16	1	16M	56.1u	-	-	295.5m
17	2	20M	50.3u	1.777m	-	445.3m
18	2	19M	62.4u	1.034m	-	513.4m
19	2	7M	82.2u	1.024m	-	349.5m

B.2 The Frequency Hopping Radar Pattern

Hopping Frequency Sequence Name: HOP_FREQ_SEQ_HT20_01

SEQ#	Frequency (Hz)	SEQ#	Frequency (Hz)	SEQ#	Frequency (Hz)	SEQ#	Frequency (Hz)
1	5.261G	2	5.721G	3	5.325G	4	5.464G
5	5.696G	6	5.424G	7	5.312G	8	5.284G
9	5.619G	10	5.256G	11	5.602G	12	5.473G
13	5.314G	14	5.268G	15	5.537G	16	5.380G
17	5.512G	18	5.281G	19	5.309G	20	5.595G
21	5.559G	22	5.344G	23	5.662G	24	5.637G
25	5.700G	26	5.386G	27	5.609G	28	5.704G
29	5.376G	30	5.258G	31	5.318G	32	5.370G
33	5.469G	34	5.586G	35	5.561G	36	5.402G
37	5.429G	38	5.414G	39	5.406G	40	5.340G
41	5.578G	42	5.443G	43	5.668G	44	5.564G
45	5.361G	46	5.324G	47	5.418G	48	5.532G



A D T

49	5.610G	50	5.471G	51	5.493G	52	5.468G
53	5.514G	54	5.552G	55	5.430G	56	5.287G
57	5.521G	58	5.695G	59	5.298G	60	5.348G
61	5.253G	62	5.452G	63	5.345G	64	5.548G
65	5.496G	66	5.337G	67	5.494G	68	5.689G
69	5.682G	70	5.529G	71	5.697G	72	5.582G
73	5.463G	74	5.621G	75	5.690G	76	5.638G
77	5.276G	78	5.291G	79	5.357G	80	5.501G
81	5.572G	82	5.264G	83	5.641G	84	5.706G
85	5.709G	86	5.277G	87	5.715G	88	5.289G
89	5.293G	90	5.698G	91	5.423G	92	5.319G
93	5.712G	94	5.676G	95	5.624G	96	5.659G
97	5.392G	98	5.672G	99	5.410G	100	5.691G

Hopping Frequency Sequence Name: HOP_FREQ_SEQ_HT20_02

SEQ#	Frequency (Hz)	SEQ#	Frequency (Hz)	SEQ#	Frequency (Hz)	SEQ#	Frequency (Hz)
1	5.658G	2	5.548G	3	5.628G	4	5.337G
5	5.361G	6	5.433G	7	5.575G	8	5.333G
9	5.714G	10	5.545G	11	5.639G	12	5.520G
13	5.320G	14	5.251G	15	5.288G	16	5.466G
17	5.547G	18	5.660G	19	5.303G	20	5.498G
21	5.369G	22	5.296G	23	5.388G	24	5.453G
25	5.283G	26	5.597G	27	5.719G	28	5.579G
29	5.297G	30	5.555G	31	5.668G	32	5.682G
33	5.590G	34	5.405G	35	5.694G	36	5.439G
37	5.566G	38	5.693G	39	5.581G	40	5.314G
41	5.583G	42	5.446G	43	5.527G	44	5.551G
45	5.371G	46	5.290G	47	5.571G	48	5.484G
49	5.400G	50	5.292G	51	5.356G	52	5.463G
53	5.289G	54	5.632G	55	5.353G	56	5.458G
57	5.457G	58	5.260G	59	5.437G	60	5.476G
61	5.299G	62	5.444G	63	5.705G	64	5.651G
65	5.708G	66	5.291G	67	5.402G	68	5.543G
69	5.318G	70	5.538G	71	5.441G	72	5.381G
73	5.374G	74	5.506G	75	5.624G	76	5.565G
77	5.544G	78	5.298G	79	5.486G	80	5.621G
81	5.692G	82	5.295G	83	5.430G	84	5.306G
85	5.493G	86	5.359G	87	5.254G	88	5.609G
89	5.688G	90	5.534G	91	5.502G	92	5.315G
93	5.670G	94	5.653G	95	5.557G	96	5.349G
97	5.629G	98	5.524G	99	5.700G	100	5.386G



A D T

Hopping Frequency Sequence Name: HOP_FREQ_SEQ_HT20_03							
SEQ#	Frequency (Hz)	SEQ#	Frequency (Hz)	SEQ#	Frequency (Hz)	SEQ#	Frequency (Hz)
1	5.522G	2	5.569G	3	5.286G	4	5.374G
5	5.506G	6	5.566G	7	5.410G	8	5.449G
9	5.674G	10	5.660G	11	5.654G	12	5.333G
13	5.285G	14	5.710G	15	5.606G	16	5.649G
17	5.708G	18	5.460G	19	5.508G	20	5.281G
21	5.263G	22	5.459G	23	5.385G	24	5.345G
25	5.562G	26	5.305G	27	5.429G	28	5.619G
29	5.723G	30	5.620G	31	5.362G	32	5.573G
33	5.456G	34	5.367G	35	5.266G	36	5.565G
37	5.477G	38	5.629G	39	5.447G	40	5.700G
41	5.387G	42	5.513G	43	5.346G	44	5.527G
45	5.577G	46	5.468G	47	5.602G	48	5.375G
49	5.274G	50	5.534G	51	5.336G	52	5.574G
53	5.612G	54	5.254G	55	5.621G	56	5.716G
57	5.613G	58	5.556G	59	5.646G	60	5.523G
61	5.706G	62	5.627G	63	5.640G	64	5.353G
65	5.409G	66	5.280G	67	5.501G	68	5.592G
69	5.712G	70	5.518G	71	5.547G	72	5.548G
73	5.258G	74	5.351G	75	5.587G	76	5.330G
77	5.304G	78	5.262G	79	5.484G	80	5.678G
81	5.647G	82	5.667G	83	5.469G	84	5.458G
85	5.724G	86	5.526G	87	5.662G	88	5.255G
89	5.683G	90	5.322G	91	5.308G	92	5.704G
93	5.490G	94	5.328G	95	5.418G	96	5.252G
97	5.435G	98	5.337G	99	5.536G	100	5.302G

Hopping Frequency Sequence Name: HOP_FREQ_SEQ_HT20_04							
SEQ#	Frequency (Hz)	SEQ#	Frequency (Hz)	SEQ#	Frequency (Hz)	SEQ#	Frequency (Hz)
1	5.359G	2	5.315G	3	5.600G	4	5.443G
5	5.490G	6	5.564G	7	5.670G	8	5.594G
9	5.446G	10	5.696G	11	5.599G	12	5.251G
13	5.722G	14	5.313G	15	5.583G	16	5.493G
17	5.596G	18	5.331G	19	5.683G	20	5.253G
21	5.386G	22	5.709G	23	5.283G	24	5.661G
25	5.540G	26	5.355G	27	5.280G	28	5.704G
29	5.495G	30	5.427G	31	5.595G	32	5.667G
33	5.501G	34	5.263G	35	5.552G	36	5.570G
37	5.666G	38	5.325G	39	5.414G	40	5.430G
41	5.373G	42	5.510G	43	5.440G	44	5.469G
45	5.428G	46	5.592G	47	5.381G	48	5.364G



A D T

49	5.361G	50	5.633G	51	5.458G	52	5.346G
53	5.645G	54	5.679G	55	5.279G	56	5.308G
57	5.603G	58	5.382G	59	5.269G	60	5.619G
61	5.462G	62	5.516G	63	5.404G	64	5.492G
65	5.602G	66	5.365G	67	5.657G	68	5.439G
69	5.581G	70	5.551G	71	5.573G	72	5.388G
73	5.500G	74	5.539G	75	5.598G	76	5.374G
77	5.578G	78	5.514G	79	5.641G	80	5.408G
81	5.537G	82	5.392G	83	5.580G	84	5.456G
85	5.424G	86	5.257G	87	5.385G	88	5.328G
89	5.379G	90	5.282G	91	5.435G	92	5.533G
93	5.467G	94	5.639G	95	5.324G	96	5.547G
97	5.426G	98	5.723G	99	5.334G	100	5.614G

Hopping Frequency Sequence Name: HOP_FREQ_SEQ_HT20_05							
SEQ#	Frequency (Hz)	SEQ#	Frequency (Hz)	SEQ#	Frequency (Hz)	SEQ#	Frequency (Hz)
1	5.544G	2	5.411G	3	5.674G	4	5.342G
5	5.419G	6	5.673G	7	5.520G	8	5.492G
9	5.666G	10	5.354G	11	5.595G	12	5.256G
13	5.381G	14	5.561G	15	5.298G	16	5.306G
17	5.644G	18	5.385G	19	5.628G	20	5.533G
21	5.390G	22	5.384G	23	5.716G	24	5.545G
25	5.647G	26	5.278G	27	5.621G	28	5.321G
29	5.456G	30	5.352G	31	5.320G	32	5.427G
33	5.315G	34	5.476G	35	5.550G	36	5.576G
37	5.418G	38	5.594G	39	5.529G	40	5.705G
41	5.266G	42	5.465G	43	5.297G	44	5.537G
45	5.680G	46	5.522G	47	5.648G	48	5.568G
49	5.636G	50	5.290G	51	5.491G	52	5.424G
53	5.631G	54	5.295G	55	5.405G	56	5.686G
57	5.325G	58	5.535G	59	5.707G	60	5.359G
61	5.469G	62	5.580G	63	5.319G	64	5.711G
65	5.335G	66	5.527G	67	5.590G	68	5.407G
69	5.703G	70	5.547G	71	5.393G	72	5.552G
73	5.689G	74	5.337G	75	5.279G	76	5.499G
77	5.484G	78	5.569G	79	5.656G	80	5.414G
81	5.277G	82	5.438G	83	5.463G	84	5.669G
85	5.625G	86	5.719G	87	5.593G	88	5.515G
89	5.369G	90	5.720G	91	5.565G	92	5.617G
93	5.660G	94	5.350G	95	5.513G	96	5.349G
97	5.285G	98	5.603G	99	5.274G	100	5.339G



A D T

Hopping Frequency Sequence Name: HOP_FREQ_SEQ_HT20_06

SEQ#	Frequency (Hz)	SEQ#	Frequency (Hz)	SEQ#	Frequency (Hz)	SEQ#	Frequency (Hz)
1	5.467G	2	5.384G	3	5.677G	4	5.720G
5	5.479G	6	5.632G	7	5.698G	8	5.550G
9	5.253G	10	5.275G	11	5.308G	12	5.584G
13	5.671G	14	5.517G	15	5.370G	16	5.623G
17	5.607G	18	5.689G	19	5.621G	20	5.330G
21	5.254G	22	5.458G	23	5.300G	24	5.373G
25	5.270G	26	5.585G	27	5.492G	28	5.508G
29	5.462G	30	5.484G	31	5.691G	32	5.552G
33	5.497G	34	5.252G	35	5.407G	36	5.357G
37	5.596G	38	5.631G	39	5.307G	40	5.454G
41	5.510G	42	5.593G	43	5.322G	44	5.288G
45	5.418G	46	5.318G	47	5.518G	48	5.715G
49	5.411G	50	5.426G	51	5.604G	52	5.542G
53	5.569G	54	5.284G	55	5.287G	56	5.324G
57	5.643G	58	5.250G	59	5.362G	60	5.599G
61	5.554G	62	5.648G	63	5.268G	64	5.659G
65	5.310G	66	5.545G	67	5.309G	68	5.388G
69	5.706G	70	5.468G	71	5.345G	72	5.372G
73	5.721G	74	5.475G	75	5.361G	76	5.446G
77	5.537G	78	5.606G	79	5.629G	80	5.389G
81	5.649G	82	5.399G	83	5.647G	84	5.652G
85	5.722G	86	5.683G	87	5.562G	88	5.265G
89	5.481G	90	5.577G	91	5.262G	92	5.486G
93	5.678G	94	5.549G	95	5.676G	96	5.630G
97	5.439G	98	5.494G	99	5.653G	100	5.501G

Hopping Frequency Sequence Name: HOP_FREQ_SEQ_HT20_07

SEQ#	Frequency (Hz)	SEQ#	Frequency (Hz)	SEQ#	Frequency (Hz)	SEQ#	Frequency (Hz)
1	5.317G	2	5.703G	3	5.430G	4	5.426G
5	5.388G	6	5.665G	7	5.371G	8	5.627G
9	5.636G	10	5.329G	11	5.570G	12	5.403G
13	5.266G	14	5.262G	15	5.700G	16	5.418G
17	5.584G	18	5.666G	19	5.361G	20	5.659G
21	5.363G	22	5.563G	23	5.568G	24	5.533G
25	5.335G	26	5.281G	27	5.253G	28	5.473G
29	5.571G	30	5.333G	31	5.524G	32	5.619G
33	5.443G	34	5.622G	35	5.544G	36	5.588G
37	5.370G	38	5.672G	39	5.642G	40	5.490G
41	5.710G	42	5.691G	43	5.330G	44	5.311G
45	5.654G	46	5.512G	47	5.674G	48	5.543G



A D T

49	5.644G	50	5.383G	51	5.325G	52	5.591G
53	5.308G	54	5.514G	55	5.386G	56	5.267G
57	5.587G	58	5.328G	59	5.658G	60	5.359G
61	5.316G	62	5.685G	63	5.551G	64	5.558G
65	5.617G	66	5.639G	67	5.295G	68	5.280G
69	5.483G	70	5.717G	71	5.500G	72	5.695G
73	5.625G	74	5.493G	75	5.681G	76	5.441G
77	5.640G	78	5.337G	79	5.582G	80	5.601G
81	5.336G	82	5.714G	83	5.327G	84	5.362G
85	5.722G	86	5.380G	87	5.252G	88	5.274G
89	5.554G	90	5.534G	91	5.696G	92	5.486G
93	5.256G	94	5.682G	95	5.452G	96	5.553G
97	5.595G	98	5.699G	99	5.382G	100	5.508G

Hopping Frequency Sequence Name: HOP_FREQ_SEQ_HT20_08							
SEQ#	Frequency (Hz)	SEQ#	Frequency (Hz)	SEQ#	Frequency (Hz)	SEQ#	Frequency (Hz)
1	5.279G	2	5.417G	3	5.366G	4	5.320G
5	5.504G	6	5.450G	7	5.521G	8	5.309G
9	5.292G	10	5.431G	11	5.254G	12	5.264G
13	5.486G	14	5.541G	15	5.361G	16	5.327G
17	5.664G	18	5.587G	19	5.358G	20	5.448G
21	5.588G	22	5.684G	23	5.680G	24	5.489G
25	5.709G	26	5.582G	27	5.567G	28	5.369G
29	5.377G	30	5.694G	31	5.257G	32	5.600G
33	5.313G	34	5.442G	35	5.638G	36	5.618G
37	5.673G	38	5.715G	39	5.389G	40	5.281G
41	5.572G	42	5.296G	43	5.394G	44	5.444G
45	5.362G	46	5.282G	47	5.376G	48	5.700G
49	5.500G	50	5.497G	51	5.564G	52	5.476G
53	5.711G	54	5.530G	55	5.293G	56	5.334G
57	5.712G	58	5.668G	59	5.672G	60	5.558G
61	5.488G	62	5.328G	63	5.524G	64	5.436G
65	5.501G	66	5.388G	67	5.270G	68	5.446G
69	5.432G	70	5.465G	71	5.348G	72	5.312G
73	5.705G	74	5.462G	75	5.555G	76	5.650G
77	5.329G	78	5.710G	79	5.316G	80	5.401G
81	5.375G	82	5.449G	83	5.671G	84	5.345G
85	5.330G	86	5.581G	87	5.627G	88	5.601G
89	5.682G	90	5.534G	91	5.402G	92	5.385G
93	5.663G	94	5.606G	95	5.322G	96	5.525G
97	5.506G	98	5.359G	99	5.291G	100	5.713G



A D T

Hopping Frequency Sequence Name: HOP_FREQ_SEQ_HT20_09							
SEQ#	Frequency (Hz)	SEQ#	Frequency (Hz)	SEQ#	Frequency (Hz)	SEQ#	Frequency (Hz)
1	5.398G	2	5.294G	3	5.490G	4	5.354G
5	5.623G	6	5.339G	7	5.624G	8	5.502G
9	5.379G	10	5.698G	11	5.454G	12	5.260G
13	5.255G	14	5.629G	15	5.325G	16	5.691G
17	5.664G	18	5.659G	19	5.498G	20	5.365G
21	5.662G	22	5.530G	23	5.408G	24	5.254G
25	5.300G	26	5.392G	27	5.540G	28	5.644G
29	5.481G	30	5.460G	31	5.304G	32	5.719G
33	5.473G	34	5.529G	35	5.682G	36	5.667G
37	5.395G	38	5.393G	39	5.597G	40	5.710G
41	5.723G	42	5.559G	43	5.372G	44	5.517G
45	5.272G	46	5.438G	47	5.343G	48	5.678G
49	5.330G	50	5.567G	51	5.680G	52	5.671G
53	5.613G	54	5.686G	55	5.484G	56	5.396G
57	5.380G	58	5.676G	59	5.535G	60	5.651G
61	5.500G	62	5.276G	63	5.444G	64	5.625G
65	5.285G	66	5.324G	67	5.329G	68	5.465G
69	5.485G	70	5.555G	71	5.331G	72	5.419G
73	5.317G	74	5.598G	75	5.400G	76	5.390G
77	5.522G	78	5.335G	79	5.336G	80	5.371G
81	5.675G	82	5.291G	83	5.334G	84	5.305G
85	5.687G	86	5.374G	87	5.700G	88	5.621G
89	5.467G	90	5.386G	91	5.546G	92	5.611G
93	5.639G	94	5.322G	95	5.568G	96	5.580G
97	5.341G	98	5.259G	99	5.572G	100	5.702G

Hopping Frequency Sequence Name: HOP_FREQ_SEQ_HT20_10							
SEQ#	Frequency (Hz)	SEQ#	Frequency (Hz)	SEQ#	Frequency (Hz)	SEQ#	Frequency (Hz)
1	5.359G	2	5.273G	3	5.322G	4	5.682G
5	5.582G	6	5.479G	7	5.390G	8	5.716G
9	5.522G	10	5.378G	11	5.341G	12	5.666G
13	5.326G	14	5.296G	15	5.344G	16	5.459G
17	5.498G	18	5.393G	19	5.554G	20	5.427G
21	5.596G	22	5.540G	23	5.431G	24	5.600G
25	5.419G	26	5.530G	27	5.403G	28	5.254G
29	5.601G	30	5.687G	31	5.338G	32	5.702G
33	5.413G	34	5.526G	35	5.699G	36	5.520G
37	5.321G	38	5.262G	39	5.470G	40	5.606G
41	5.285G	42	5.412G	43	5.722G	44	5.609G
45	5.615G	46	5.490G	47	5.434G	48	5.271G



A D T

49	5.688G	50	5.566G	51	5.392G	52	5.302G
53	5.573G	54	5.367G	55	5.684G	56	5.328G
57	5.425G	58	5.320G	59	5.579G	60	5.602G
61	5.380G	62	5.670G	63	5.574G	64	5.365G
65	5.539G	66	5.260G	67	5.583G	68	5.667G
69	5.689G	70	5.692G	71	5.564G	72	5.319G
73	5.580G	74	5.286G	75	5.349G	76	5.495G
77	5.575G	78	5.531G	79	5.251G	80	5.694G
81	5.584G	82	5.710G	83	5.379G	84	5.706G
85	5.641G	86	5.517G	87	5.489G	88	5.436G
89	5.546G	90	5.673G	91	5.476G	92	5.377G
93	5.518G	94	5.631G	95	5.473G	96	5.315G
97	5.267G	98	5.550G	99	5.386G	100	5.642G

Hopping Frequency Sequence Name: HOP_FREQ_SEQ_HT20_11

SEQ#	Frequency (Hz)	SEQ#	Frequency (Hz)	SEQ#	Frequency (Hz)	SEQ#	Frequency (Hz)
1	5.437G	2	5.412G	3	5.260G	4	5.485G
5	5.700G	6	5.648G	7	5.602G	8	5.623G
9	5.566G	10	5.503G	11	5.433G	12	5.665G
13	5.323G	14	5.613G	15	5.686G	16	5.642G
17	5.320G	18	5.270G	19	5.441G	20	5.596G
21	5.393G	22	5.651G	23	5.386G	24	5.679G
25	5.302G	26	5.601G	27	5.555G	28	5.644G
29	5.677G	30	5.507G	31	5.415G	32	5.389G
33	5.348G	34	5.634G	35	5.452G	36	5.687G
37	5.682G	38	5.469G	39	5.579G	40	5.661G
41	5.448G	42	5.410G	43	5.427G	44	5.358G
45	5.301G	46	5.253G	47	5.675G	48	5.288G
49	5.325G	50	5.519G	51	5.538G	52	5.697G
53	5.361G	54	5.641G	55	5.546G	56	5.517G
57	5.331G	58	5.513G	59	5.460G	60	5.321G
61	5.286G	62	5.653G	63	5.693G	64	5.678G
65	5.402G	66	5.568G	67	5.492G	68	5.423G
69	5.322G	70	5.372G	71	5.628G	72	5.627G
73	5.581G	74	5.488G	75	5.315G	76	5.585G
77	5.368G	78	5.375G	79	5.667G	80	5.530G
81	5.545G	82	5.685G	83	5.454G	84	5.695G
85	5.345G	86	5.521G	87	5.495G	88	5.475G
89	5.466G	90	5.486G	91	5.391G	92	5.590G
93	5.614G	94	5.537G	95	5.706G	96	5.327G
97	5.440G	98	5.522G	99	5.684G	100	5.387G



A D T

Hopping Frequency Sequence Name: HOP_FREQ_SEQ_HT20_12							
SEQ#	Frequency (Hz)	SEQ#	Frequency (Hz)	SEQ#	Frequency (Hz)	SEQ#	Frequency (Hz)
1	5.394G	2	5.460G	3	5.593G	4	5.325G
5	5.561G	6	5.520G	7	5.327G	8	5.573G
9	5.517G	10	5.287G	11	5.649G	12	5.254G
13	5.567G	14	5.587G	15	5.637G	16	5.663G
17	5.299G	18	5.462G	19	5.524G	20	5.418G
21	5.616G	22	5.321G	23	5.605G	24	5.300G
25	5.268G	26	5.540G	27	5.406G	28	5.611G
29	5.414G	30	5.480G	31	5.309G	32	5.681G
33	5.492G	34	5.497G	35	5.643G	36	5.565G
37	5.539G	38	5.250G	39	5.668G	40	5.568G
41	5.585G	42	5.588G	43	5.269G	44	5.310G
45	5.338G	46	5.675G	47	5.271G	48	5.353G
49	5.625G	50	5.537G	51	5.345G	52	5.417G
53	5.670G	54	5.583G	55	5.476G	56	5.598G
57	5.389G	58	5.351G	59	5.709G	60	5.356G
61	5.469G	62	5.656G	63	5.478G	64	5.431G
65	5.429G	66	5.307G	67	5.369G	68	5.722G
69	5.529G	70	5.487G	71	5.613G	72	5.575G
73	5.445G	74	5.428G	75	5.305G	76	5.706G
77	5.452G	78	5.633G	79	5.614G	80	5.408G
81	5.563G	82	5.592G	83	5.381G	84	5.514G
85	5.471G	86	5.511G	87	5.578G	88	5.337G
89	5.653G	90	5.695G	91	5.569G	92	5.289G
93	5.363G	94	5.674G	95	5.584G	96	5.354G
97	5.642G	98	5.503G	99	5.612G	100	5.550G

Hopping Frequency Sequence Name: HOP_FREQ_SEQ_HT20_13							
SEQ#	Frequency (Hz)	SEQ#	Frequency (Hz)	SEQ#	Frequency (Hz)	SEQ#	Frequency (Hz)
1	5.472G	2	5.372G	3	5.431G	4	5.509G
5	5.331G	6	5.444G	7	5.441G	8	5.590G
9	5.309G	10	5.379G	11	5.320G	12	5.460G
13	5.325G	14	5.713G	15	5.664G	16	5.356G
17	5.559G	18	5.353G	19	5.440G	20	5.267G
21	5.533G	22	5.596G	23	5.367G	24	5.691G
25	5.269G	26	5.482G	27	5.519G	28	5.315G
29	5.654G	30	5.352G	31	5.458G	32	5.665G
33	5.711G	34	5.406G	35	5.514G	36	5.388G
37	5.624G	38	5.502G	39	5.539G	40	5.701G
41	5.448G	42	5.708G	43	5.675G	44	5.408G
45	5.414G	46	5.337G	47	5.384G	48	5.257G



A D T

49	5.682G	50	5.698G	51	5.347G	52	5.607G
53	5.422G	54	5.628G	55	5.364G	56	5.681G
57	5.593G	58	5.317G	59	5.297G	60	5.281G
61	5.428G	62	5.254G	63	5.491G	64	5.535G
65	5.721G	66	5.339G	67	5.663G	68	5.354G
69	5.695G	70	5.255G	71	5.536G	72	5.673G
73	5.427G	74	5.289G	75	5.429G	76	5.699G
77	5.668G	78	5.679G	79	5.330G	80	5.709G
81	5.552G	82	5.439G	83	5.560G	84	5.492G
85	5.375G	86	5.457G	87	5.543G	88	5.511G
89	5.498G	90	5.605G	91	5.485G	92	5.620G
93	5.551G	94	5.493G	95	5.477G	96	5.627G
97	5.696G	98	5.293G	99	5.571G	100	5.542G

Hopping Frequency Sequence Name: HOP_FREQ_SEQ_HT20_14

SEQ#	Frequency (Hz)	SEQ#	Frequency (Hz)	SEQ#	Frequency (Hz)	SEQ#	Frequency (Hz)
1	5.429G	2	5.540G	3	5.654G	4	5.554G
5	5.278G	6	5.634G	7	5.719G	8	5.476G
9	5.439G	10	5.664G	11	5.332G	12	5.395G
13	5.581G	14	5.402G	15	5.580G	16	5.551G
17	5.604G	18	5.466G	19	5.488G	20	5.534G
21	5.387G	22	5.609G	23	5.588G	24	5.286G
25	5.619G	26	5.281G	27	5.359G	28	5.553G
29	5.535G	30	5.418G	31	5.406G	32	5.494G
33	5.360G	34	5.716G	35	5.487G	36	5.503G
37	5.409G	38	5.309G	39	5.422G	40	5.400G
41	5.304G	42	5.396G	43	5.276G	44	5.474G
45	5.434G	46	5.426G	47	5.353G	48	5.704G
49	5.280G	50	5.686G	51	5.678G	52	5.458G
53	5.358G	54	5.642G	55	5.620G	56	5.348G
57	5.277G	58	5.250G	59	5.607G	60	5.703G
61	5.454G	62	5.514G	63	5.572G	64	5.508G
65	5.500G	66	5.346G	67	5.611G	68	5.373G
69	5.643G	70	5.486G	71	5.645G	72	5.707G
73	5.323G	74	5.388G	75	5.550G	76	5.303G
77	5.657G	78	5.571G	79	5.378G	80	5.544G
81	5.706G	82	5.441G	83	5.269G	84	5.519G
85	5.590G	86	5.416G	87	5.368G	88	5.334G
89	5.328G	90	5.624G	91	5.542G	92	5.306G
93	5.444G	94	5.517G	95	5.471G	96	5.516G
97	5.610G	98	5.546G	99	5.366G	100	5.344G



A D T

Hopping Frequency Sequence Name: HOP_FREQ_SEQ_HT20_15

SEQ#	Frequency (Hz)	SEQ#	Frequency (Hz)	SEQ#	Frequency (Hz)	SEQ#	Frequency (Hz)
1	5.301G	2	5.431G	3	5.644G	4	5.389G
5	5.529G	6	5.706G	7	5.495G	8	5.454G
9	5.461G	10	5.304G	11	5.590G	12	5.649G
13	5.625G	14	5.651G	15	5.398G	16	5.297G
17	5.269G	18	5.570G	19	5.722G	20	5.562G
21	5.259G	22	5.481G	23	5.254G	24	5.539G
25	5.380G	26	5.441G	27	5.621G	28	5.561G
29	5.583G	30	5.467G	31	5.273G	32	5.315G
33	5.270G	34	5.682G	35	5.387G	36	5.656G
37	5.538G	38	5.316G	39	5.355G	40	5.579G
41	5.412G	42	5.588G	43	5.310G	44	5.512G
45	5.251G	46	5.691G	47	5.392G	48	5.527G
49	5.252G	50	5.437G	51	5.265G	52	5.338G
53	5.556G	54	5.348G	55	5.299G	56	5.489G
57	5.470G	58	5.560G	59	5.518G	60	5.320G
61	5.395G	62	5.705G	63	5.620G	64	5.360G
65	5.499G	66	5.423G	67	5.547G	68	5.430G
69	5.626G	70	5.657G	71	5.688G	72	5.471G
73	5.634G	74	5.696G	75	5.477G	76	5.347G
77	5.303G	78	5.460G	79	5.407G	80	5.604G
81	5.599G	82	5.487G	83	5.577G	84	5.333G
85	5.302G	86	5.260G	87	5.534G	88	5.463G
89	5.637G	90	5.672G	91	5.551G	92	5.426G
93	5.506G	94	5.450G	95	5.681G	96	5.458G
97	5.405G	98	5.643G	99	5.339G	100	5.513G

Hopping Frequency Sequence Name: HOP_FREQ_SEQ_HT20_16

SEQ#	Frequency (Hz)	SEQ#	Frequency (Hz)	SEQ#	Frequency (Hz)	SEQ#	Frequency (Hz)
1	5.302G	2	5.414G	3	5.555G	4	5.445G
5	5.289G	6	5.543G	7	5.712G	8	5.691G
9	5.344G	10	5.692G	11	5.446G	12	5.633G
13	5.614G	14	5.554G	15	5.601G	16	5.469G
17	5.637G	18	5.611G	19	5.672G	20	5.334G
21	5.708G	22	5.658G	23	5.560G	24	5.276G
25	5.564G	26	5.480G	27	5.420G	28	5.676G
29	5.598G	30	5.700G	31	5.552G	32	5.370G
33	5.579G	34	5.675G	35	5.280G	36	5.640G
37	5.451G	38	5.331G	39	5.256G	40	5.547G
41	5.454G	42	5.403G	43	5.491G	44	5.335G
45	5.434G	46	5.605G	47	5.705G	48	5.371G



A D T

49	5.477G	50	5.399G	51	5.539G	52	5.518G
53	5.423G	54	5.600G	55	5.313G	56	5.527G
57	5.537G	58	5.648G	59	5.662G	60	5.470G
61	5.575G	62	5.505G	63	5.510G	64	5.422G
65	5.644G	66	5.421G	67	5.404G	68	5.532G
69	5.545G	70	5.630G	71	5.719G	72	5.512G
73	5.351G	74	5.297G	75	5.567G	76	5.377G
77	5.269G	78	5.412G	79	5.683G	80	5.279G
81	5.488G	82	5.458G	83	5.419G	84	5.715G
85	5.625G	86	5.407G	87	5.286G	88	5.390G
89	5.452G	90	5.264G	91	5.442G	92	5.707G
93	5.500G	94	5.696G	95	5.278G	96	5.448G
97	5.366G	98	5.713G	99	5.262G	100	5.608G

Hopping Frequency Sequence Name: HOP_FREQ_SEQ_HT20_17							
SEQ#	Frequency (Hz)	SEQ#	Frequency (Hz)	SEQ#	Frequency (Hz)	SEQ#	Frequency (Hz)
1	5.589G	2	5.594G	3	5.526G	4	5.709G
5	5.279G	6	5.474G	7	5.250G	8	5.422G
9	5.617G	10	5.505G	11	5.438G	12	5.295G
13	5.469G	14	5.619G	15	5.635G	16	5.376G
17	5.450G	18	5.649G	19	5.476G	20	5.362G
21	5.486G	22	5.409G	23	5.306G	24	5.430G
25	5.444G	26	5.551G	27	5.299G	28	5.678G
29	5.710G	30	5.620G	31	5.677G	32	5.577G
33	5.322G	34	5.411G	35	5.502G	36	5.307G
37	5.570G	38	5.564G	39	5.389G	40	5.491G
41	5.399G	42	5.549G	43	5.590G	44	5.272G
45	5.598G	46	5.485G	47	5.621G	48	5.314G
49	5.443G	50	5.470G	51	5.679G	52	5.585G
53	5.462G	54	5.588G	55	5.366G	56	5.370G
57	5.540G	58	5.418G	59	5.492G	60	5.282G
61	5.724G	62	5.512G	63	5.535G	64	5.461G
65	5.425G	66	5.573G	67	5.468G	68	5.644G
69	5.636G	70	5.637G	71	5.680G	72	5.367G
73	5.442G	74	5.350G	75	5.722G	76	5.670G
77	5.415G	78	5.531G	79	5.358G	80	5.684G
81	5.703G	82	5.458G	83	5.600G	84	5.441G
85	5.386G	86	5.548G	87	5.717G	88	5.480G
89	5.683G	90	5.508G	91	5.667G	92	5.284G
93	5.259G	94	5.303G	95	5.544G	96	5.569G
97	5.541G	98	5.542G	99	5.311G	100	5.426G



A D T

Hopping Frequency Sequence Name: HOP_FREQ_SEQ_HT20_18							
SEQ#	Frequency (Hz)	SEQ#	Frequency (Hz)	SEQ#	Frequency (Hz)	SEQ#	Frequency (Hz)
1	5.391G	2	5.281G	3	5.645G	4	5.672G
5	5.572G	6	5.562G	7	5.447G	8	5.401G
9	5.345G	10	5.488G	11	5.272G	12	5.680G
13	5.495G	14	5.691G	15	5.328G	16	5.255G
17	5.557G	18	5.650G	19	5.357G	20	5.554G
21	5.624G	22	5.600G	23	5.504G	24	5.710G
25	5.315G	26	5.431G	27	5.587G	28	5.443G
29	5.321G	30	5.308G	31	5.458G	32	5.430G
33	5.465G	34	5.439G	35	5.254G	36	5.633G
37	5.343G	38	5.612G	39	5.436G	40	5.552G
41	5.553G	42	5.607G	43	5.586G	44	5.582G
45	5.720G	46	5.683G	47	5.293G	48	5.660G
49	5.662G	50	5.261G	51	5.448G	52	5.384G
53	5.619G	54	5.291G	55	5.311G	56	5.307G
57	5.606G	58	5.614G	59	5.271G	60	5.578G
61	5.459G	62	5.707G	63	5.690G	64	5.454G
65	5.330G	66	5.682G	67	5.387G	68	5.354G
69	5.501G	70	5.637G	71	5.493G	72	5.589G
73	5.266G	74	5.358G	75	5.348G	76	5.367G
77	5.701G	78	5.541G	79	5.461G	80	5.336G
81	5.661G	82	5.350G	83	5.685G	84	5.340G
85	5.406G	86	5.699G	87	5.300G	88	5.376G
89	5.299G	90	5.641G	91	5.639G	92	5.292G
93	5.318G	94	5.632G	95	5.463G	96	5.290G
97	5.325G	98	5.408G	99	5.681G	100	5.385G

Hopping Frequency Sequence Name: HOP_FREQ_SEQ_HT20_19							
SEQ#	Frequency (Hz)	SEQ#	Frequency (Hz)	SEQ#	Frequency (Hz)	SEQ#	Frequency (Hz)
1	5.333G	2	5.273G	3	5.610G	4	5.267G
5	5.711G	6	5.317G	7	5.492G	8	5.256G
9	5.422G	10	5.551G	11	5.277G	12	5.263G
13	5.601G	14	5.565G	15	5.686G	16	5.531G
17	5.289G	18	5.660G	19	5.471G	20	5.589G
21	5.283G	22	5.445G	23	5.405G	24	5.434G
25	5.286G	26	5.396G	27	5.597G	28	5.631G
29	5.664G	30	5.314G	31	5.652G	32	5.590G
33	5.506G	34	5.653G	35	5.278G	36	5.358G
37	5.695G	38	5.575G	39	5.274G	40	5.502G
41	5.364G	42	5.440G	43	5.650G	44	5.495G
45	5.640G	46	5.679G	47	5.677G	48	5.380G



A D T

49	5.675G	50	5.561G	51	5.437G	52	5.282G
53	5.591G	54	5.521G	55	5.330G	56	5.555G
57	5.673G	58	5.648G	59	5.550G	60	5.420G
61	5.417G	62	5.484G	63	5.461G	64	5.397G
65	5.569G	66	5.297G	67	5.499G	68	5.370G
69	5.608G	70	5.674G	71	5.616G	72	5.538G
73	5.698G	74	5.253G	75	5.603G	76	5.491G
77	5.719G	78	5.720G	79	5.688G	80	5.395G
81	5.414G	82	5.559G	83	5.480G	84	5.311G
85	5.627G	86	5.649G	87	5.692G	88	5.507G
89	5.705G	90	5.657G	91	5.424G	92	5.319G
93	5.598G	94	5.701G	95	5.298G	96	5.702G
97	5.477G	98	5.536G	99	5.634G	100	5.515G

Hopping Frequency Sequence Name: HOP_FREQ_SEQ_HT20_20

SEQ#	Frequency (Hz)	SEQ#	Frequency (Hz)	SEQ#	Frequency (Hz)	SEQ#	Frequency (Hz)
1	5.569G	2	5.662G	3	5.449G	4	5.441G
5	5.547G	6	5.681G	7	5.402G	8	5.509G
9	5.268G	10	5.443G	11	5.336G	12	5.382G
13	5.304G	14	5.292G	15	5.477G	16	5.664G
17	5.300G	18	5.311G	19	5.613G	20	5.645G
21	5.384G	22	5.643G	23	5.453G	24	5.364G
25	5.621G	26	5.337G	27	5.512G	28	5.656G
29	5.281G	30	5.548G	31	5.351G	32	5.422G
33	5.599G	34	5.508G	35	5.619G	36	5.624G
37	5.387G	38	5.376G	39	5.593G	40	5.489G
41	5.275G	42	5.522G	43	5.670G	44	5.716G
45	5.435G	46	5.680G	47	5.693G	48	5.557G
49	5.439G	50	5.531G	51	5.418G	52	5.434G
53	5.408G	54	5.574G	55	5.529G	56	5.702G
57	5.519G	58	5.618G	59	5.637G	60	5.715G
61	5.568G	62	5.413G	63	5.628G	64	5.454G
65	5.471G	66	5.601G	67	5.251G	68	5.582G
69	5.386G	70	5.649G	71	5.259G	72	5.626G
73	5.636G	74	5.510G	75	5.250G	76	5.555G
77	5.396G	78	5.377G	79	5.314G	80	5.294G
81	5.654G	82	5.272G	83	5.366G	84	5.657G
85	5.461G	86	5.642G	87	5.684G	88	5.399G
89	5.541G	90	5.650G	91	5.427G	92	5.588G
93	5.464G	94	5.600G	95	5.370G	96	5.724G
97	5.647G	98	5.293G	99	5.403G	100	5.291G



A D T

Hopping Frequency Sequence Name: HOP_FREQ_SEQ_HT20_21							
SEQ#	Frequency (Hz)	SEQ#	Frequency (Hz)	SEQ#	Frequency (Hz)	SEQ#	Frequency (Hz)
1	5.411G	2	5.589G	3	5.483G	4	5.679G
5	5.410G	6	5.583G	7	5.399G	8	5.354G
9	5.426G	10	5.637G	11	5.588G	12	5.699G
13	5.439G	14	5.587G	15	5.710G	16	5.419G
17	5.631G	18	5.330G	19	5.444G	20	5.456G
21	5.569G	22	5.351G	23	5.675G	24	5.267G
25	5.440G	26	5.485G	27	5.612G	28	5.276G
29	5.273G	30	5.470G	31	5.547G	32	5.252G
33	5.466G	34	5.586G	35	5.442G	36	5.596G
37	5.388G	38	5.719G	39	5.403G	40	5.640G
41	5.685G	42	5.436G	43	5.452G	44	5.420G
45	5.529G	46	5.549G	47	5.542G	48	5.395G
49	5.564G	50	5.438G	51	5.713G	52	5.318G
53	5.266G	54	5.425G	55	5.620G	56	5.343G
57	5.298G	58	5.313G	59	5.353G	60	5.416G
61	5.722G	62	5.606G	63	5.565G	64	5.518G
65	5.288G	66	5.605G	67	5.292G	68	5.593G
69	5.684G	70	5.550G	71	5.643G	72	5.321G
73	5.693G	74	5.338G	75	5.482G	76	5.669G
77	5.563G	78	5.308G	79	5.281G	80	5.635G
81	5.618G	82	5.289G	83	5.522G	84	5.528G
85	5.582G	86	5.320G	87	5.496G	88	5.336G
89	5.609G	90	5.497G	91	5.314G	92	5.384G
93	5.603G	94	5.471G	95	5.431G	96	5.325G
97	5.503G	98	5.674G	99	5.405G	100	5.537G

Hopping Frequency Sequence Name: HOP_FREQ_SEQ_HT20_22							
SEQ#	Frequency (Hz)	SEQ#	Frequency (Hz)	SEQ#	Frequency (Hz)	SEQ#	Frequency (Hz)
1	5.559G	2	5.331G	3	5.642G	4	5.529G
5	5.353G	6	5.261G	7	5.383G	8	5.498G
9	5.317G	10	5.543G	11	5.450G	12	5.679G
13	5.540G	14	5.253G	15	5.423G	16	5.369G
17	5.293G	18	5.628G	19	5.702G	20	5.671G
21	5.367G	22	5.272G	23	5.706G	24	5.674G
25	5.409G	26	5.547G	27	5.489G	28	5.474G
29	5.588G	30	5.554G	31	5.502G	32	5.589G
33	5.501G	34	5.412G	35	5.521G	36	5.425G
37	5.526G	38	5.564G	39	5.288G	40	5.616G
41	5.517G	42	5.318G	43	5.431G	44	5.573G
45	5.403G	46	5.464G	47	5.609G	48	5.494G



A D T

49	5.549G	50	5.650G	51	5.688G	52	5.687G
53	5.664G	54	5.495G	55	5.577G	56	5.476G
57	5.625G	58	5.711G	59	5.722G	60	5.263G
61	5.398G	62	5.362G	63	5.634G	64	5.437G
65	5.662G	66	5.328G	67	5.296G	68	5.301G
69	5.636G	70	5.453G	71	5.381G	72	5.660G
73	5.404G	74	5.352G	75	5.393G	76	5.723G
77	5.627G	78	5.684G	79	5.399G	80	5.365G
81	5.708G	82	5.536G	83	5.305G	84	5.690G
85	5.545G	86	5.416G	87	5.659G	88	5.657G
89	5.454G	90	5.666G	91	5.602G	92	5.346G
93	5.444G	94	5.506G	95	5.673G	96	5.442G
97	5.611G	98	5.430G	99	5.606G	100	5.630G

Hopping Frequency Sequence Name: HOP_FREQ_SEQ_HT20_23

SEQ#	Frequency (Hz)	SEQ#	Frequency (Hz)	SEQ#	Frequency (Hz)	SEQ#	Frequency (Hz)
1	5.628G	2	5.332G	3	5.637G	4	5.711G
5	5.441G	6	5.251G	7	5.684G	8	5.283G
9	5.461G	10	5.382G	11	5.650G	12	5.673G
13	5.397G	14	5.596G	15	5.312G	16	5.435G
17	5.341G	18	5.346G	19	5.695G	20	5.475G
21	5.420G	22	5.408G	23	5.281G	24	5.273G
25	5.638G	26	5.439G	27	5.510G	28	5.465G
29	5.530G	30	5.360G	31	5.663G	32	5.651G
33	5.656G	34	5.699G	35	5.502G	36	5.664G
37	5.342G	38	5.646G	39	5.721G	40	5.327G
41	5.425G	42	5.542G	43	5.471G	44	5.417G
45	5.456G	46	5.654G	47	5.415G	48	5.683G
49	5.253G	50	5.647G	51	5.466G	52	5.575G
53	5.580G	54	5.594G	55	5.368G	56	5.494G
57	5.479G	58	5.395G	59	5.601G	60	5.293G
61	5.297G	62	5.351G	63	5.277G	64	5.578G
65	5.657G	66	5.387G	67	5.446G	68	5.513G
69	5.680G	70	5.267G	71	5.574G	72	5.288G
73	5.687G	74	5.644G	75	5.438G	76	5.329G
77	5.586G	78	5.429G	79	5.641G	80	5.336G
81	5.317G	82	5.372G	83	5.718G	84	5.427G
85	5.340G	86	5.371G	87	5.255G	88	5.671G
89	5.536G	90	5.563G	91	5.318G	92	5.391G
93	5.470G	94	5.708G	95	5.523G	96	5.306G
97	5.440G	98	5.433G	99	5.528G	100	5.263G



A D T

Hopping Frequency Sequence Name: HOP_FREQ_SEQ_HT20_24							
SEQ#	Frequency (Hz)	SEQ#	Frequency (Hz)	SEQ#	Frequency (Hz)	SEQ#	Frequency (Hz)
1	5.555G	2	5.676G	3	5.510G	4	5.406G
5	5.550G	6	5.721G	7	5.701G	8	5.587G
9	5.557G	10	5.461G	11	5.311G	12	5.346G
13	5.341G	14	5.641G	15	5.262G	16	5.584G
17	5.686G	18	5.679G	19	5.604G	20	5.513G
21	5.717G	22	5.553G	23	5.314G	24	5.310G
25	5.568G	26	5.693G	27	5.403G	28	5.521G
29	5.588G	30	5.548G	31	5.381G	32	5.323G
33	5.591G	34	5.258G	35	5.523G	36	5.532G
37	5.275G	38	5.530G	39	5.711G	40	5.350G
41	5.640G	42	5.459G	43	5.432G	44	5.639G
45	5.625G	46	5.391G	47	5.411G	48	5.594G
49	5.487G	50	5.549G	51	5.377G	52	5.428G
53	5.280G	54	5.254G	55	5.404G	56	5.327G
57	5.418G	58	5.372G	59	5.692G	60	5.699G
61	5.251G	62	5.627G	63	5.283G	64	5.613G
65	5.607G	66	5.407G	67	5.271G	68	5.491G
69	5.297G	70	5.389G	71	5.420G	72	5.673G
73	5.415G	74	5.442G	75	5.680G	76	5.538G
77	5.302G	78	5.644G	79	5.696G	80	5.637G
81	5.480G	82	5.482G	83	5.582G	84	5.565G
85	5.575G	86	5.358G	87	5.365G	88	5.417G
89	5.394G	90	5.615G	91	5.602G	92	5.429G
93	5.653G	94	5.313G	95	5.689G	96	5.669G
97	5.287G	98	5.250G	99	5.463G	100	5.667G

Hopping Frequency Sequence Name: HOP_FREQ_SEQ_HT20_25							
SEQ#	Frequency (Hz)	SEQ#	Frequency (Hz)	SEQ#	Frequency (Hz)	SEQ#	Frequency (Hz)
1	5.561G	2	5.662G	3	5.337G	4	5.597G
5	5.498G	6	5.507G	7	5.360G	8	5.499G
9	5.295G	10	5.461G	11	5.614G	12	5.646G
13	5.267G	14	5.657G	15	5.468G	16	5.298G
17	5.652G	18	5.384G	19	5.524G	20	5.335G
21	5.380G	22	5.713G	23	5.535G	24	5.707G
25	5.350G	26	5.708G	27	5.661G	28	5.395G
29	5.309G	30	5.545G	31	5.710G	32	5.280G
33	5.283G	34	5.503G	35	5.723G	36	5.464G
37	5.685G	38	5.252G	39	5.563G	40	5.321G
41	5.676G	42	5.416G	43	5.620G	44	5.324G
45	5.719G	46	5.297G	47	5.697G	48	5.477G



A D T

49	5.473G	50	5.549G	51	5.453G	52	5.592G
53	5.504G	54	5.611G	55	5.310G	56	5.641G
57	5.406G	58	5.481G	59	5.608G	60	5.392G
61	5.595G	62	5.424G	63	5.287G	64	5.505G
65	5.695G	66	5.612G	67	5.299G	68	5.617G
69	5.286G	70	5.434G	71	5.251G	72	5.482G
73	5.683G	74	5.717G	75	5.317G	76	5.672G
77	5.548G	78	5.398G	79	5.413G	80	5.349G
81	5.658G	82	5.538G	83	5.285G	84	5.492G
85	5.253G	86	5.479G	87	5.459G	88	5.506G
89	5.556G	90	5.369G	91	5.644G	92	5.693G
93	5.675G	94	5.663G	95	5.602G	96	5.382G
97	5.628G	98	5.530G	99	5.533G	100	5.528G

Hopping Frequency Sequence Name: HOP_FREQ_SEQ_HT20_26							
SEQ#	Frequency (Hz)	SEQ#	Frequency (Hz)	SEQ#	Frequency (Hz)	SEQ#	Frequency (Hz)
1	5.438G	2	5.693G	3	5.615G	4	5.519G
5	5.658G	6	5.425G	7	5.517G	8	5.716G
9	5.361G	10	5.583G	11	5.646G	12	5.657G
13	5.385G	14	5.402G	15	5.687G	16	5.266G
17	5.271G	18	5.347G	19	5.597G	20	5.286G
21	5.301G	22	5.272G	23	5.524G	24	5.309G
25	5.463G	26	5.684G	27	5.431G	28	5.721G
29	5.527G	30	5.660G	31	5.587G	32	5.263G
33	5.434G	34	5.631G	35	5.483G	36	5.392G
37	5.258G	38	5.491G	39	5.506G	40	5.355G
41	5.697G	42	5.274G	43	5.270G	44	5.710G
45	5.253G	46	5.348G	47	5.300G	48	5.574G
49	5.334G	50	5.625G	51	5.396G	52	5.375G
53	5.395G	54	5.498G	55	5.576G	56	5.371G
57	5.423G	58	5.389G	59	5.416G	60	5.399G
61	5.699G	62	5.316G	63	5.449G	64	5.496G
65	5.652G	66	5.260G	67	5.530G	68	5.690G
69	5.365G	70	5.317G	71	5.322G	72	5.408G
73	5.290G	74	5.277G	75	5.436G	76	5.414G
77	5.323G	78	5.297G	79	5.262G	80	5.661G
81	5.539G	82	5.403G	83	5.295G	84	5.511G
85	5.465G	86	5.401G	87	5.532G	88	5.490G
89	5.454G	90	5.484G	91	5.590G	92	5.446G
93	5.335G	94	5.291G	95	5.411G	96	5.581G
97	5.305G	98	5.525G	99	5.378G	100	5.343G



A D T

Hopping Frequency Sequence Name: HOP_FREQ_SEQ_HT20_27

SEQ#	Frequency (Hz)	SEQ#	Frequency (Hz)	SEQ#	Frequency (Hz)	SEQ#	Frequency (Hz)
1	5.419G	2	5.672G	3	5.634G	4	5.617G
5	5.303G	6	5.619G	7	5.719G	8	5.563G
9	5.367G	10	5.363G	11	5.331G	12	5.296G
13	5.498G	14	5.458G	15	5.484G	16	5.317G
17	5.559G	18	5.506G	19	5.378G	20	5.422G
21	5.297G	22	5.308G	23	5.529G	24	5.270G
25	5.381G	26	5.453G	27	5.556G	28	5.645G
29	5.704G	30	5.655G	31	5.515G	32	5.624G
33	5.703G	34	5.596G	35	5.581G	36	5.641G
37	5.443G	38	5.612G	39	5.522G	40	5.546G
41	5.472G	42	5.396G	43	5.712G	44	5.315G
45	5.362G	46	5.565G	47	5.400G	48	5.625G
49	5.620G	50	5.595G	51	5.504G	52	5.511G
53	5.671G	54	5.588G	55	5.395G	56	5.651G
57	5.434G	58	5.359G	59	5.521G	60	5.294G
61	5.279G	62	5.602G	63	5.430G	64	5.647G
65	5.550G	66	5.514G	67	5.409G	68	5.262G
69	5.383G	70	5.386G	71	5.344G	72	5.678G
73	5.557G	74	5.393G	75	5.496G	76	5.706G
77	5.432G	78	5.460G	79	5.351G	80	5.542G
81	5.373G	82	5.650G	83	5.298G	84	5.501G
85	5.260G	86	5.520G	87	5.416G	88	5.701G
89	5.662G	90	5.509G	91	5.271G	92	5.613G
93	5.313G	94	5.494G	95	5.480G	96	5.336G
97	5.705G	98	5.660G	99	5.566G	100	5.599G

Hopping Frequency Sequence Name: HOP_FREQ_SEQ_HT20_28

SEQ#	Frequency (Hz)	SEQ#	Frequency (Hz)	SEQ#	Frequency (Hz)	SEQ#	Frequency (Hz)
1	5.436G	2	5.485G	3	5.300G	4	5.364G
5	5.278G	6	5.638G	7	5.635G	8	5.459G
9	5.375G	10	5.442G	11	5.597G	12	5.624G
13	5.452G	14	5.356G	15	5.413G	16	5.545G
17	5.367G	18	5.290G	19	5.411G	20	5.253G
21	5.403G	22	5.488G	23	5.443G	24	5.663G
25	5.338G	26	5.566G	27	5.255G	28	5.453G
29	5.532G	30	5.317G	31	5.540G	32	5.468G
33	5.336G	34	5.394G	35	5.575G	36	5.386G
37	5.469G	38	5.267G	39	5.521G	40	5.426G
41	5.587G	42	5.339G	43	5.329G	44	5.561G
45	5.479G	46	5.661G	47	5.613G	48	5.410G



A D T

49	5.646G	50	5.451G	51	5.534G	52	5.707G
53	5.435G	54	5.576G	55	5.578G	56	5.543G
57	5.259G	58	5.251G	59	5.346G	60	5.297G
61	5.656G	62	5.397G	63	5.554G	64	5.270G
65	5.464G	66	5.298G	67	5.721G	68	5.314G
69	5.349G	70	5.331G	71	5.605G	72	5.610G
73	5.579G	74	5.698G	75	5.309G	76	5.362G
77	5.505G	78	5.520G	79	5.389G	80	5.571G
81	5.323G	82	5.352G	83	5.276G	84	5.674G
85	5.600G	86	5.558G	87	5.631G	88	5.528G
89	5.525G	90	5.481G	91	5.345G	92	5.274G
93	5.550G	94	5.581G	95	5.420G	96	5.460G
97	5.705G	98	5.428G	99	5.400G	100	5.522G

Hopping Frequency Sequence Name: HOP_FREQ_SEQ_HT20_29							
SEQ#	Frequency (Hz)	SEQ#	Frequency (Hz)	SEQ#	Frequency (Hz)	SEQ#	Frequency (Hz)
1	5.706G	2	5.639G	3	5.609G	4	5.391G
5	5.260G	6	5.425G	7	5.608G	8	5.610G
9	5.417G	10	5.393G	11	5.420G	12	5.689G
13	5.379G	14	5.325G	15	5.570G	16	5.566G
17	5.453G	18	5.427G	19	5.716G	20	5.661G
21	5.277G	22	5.703G	23	5.688G	24	5.413G
25	5.622G	26	5.400G	27	5.631G	28	5.479G
29	5.447G	30	5.538G	31	5.389G	32	5.638G
33	5.335G	34	5.559G	35	5.687G	36	5.554G
37	5.605G	38	5.693G	39	5.717G	40	5.440G
41	5.473G	42	5.437G	43	5.627G	44	5.467G
45	5.446G	46	5.404G	47	5.651G	48	5.642G
49	5.373G	50	5.300G	51	5.350G	52	5.646G
53	5.505G	54	5.504G	55	5.604G	56	5.636G
57	5.296G	58	5.294G	59	5.676G	60	5.380G
61	5.583G	62	5.587G	63	5.510G	64	5.306G
65	5.493G	66	5.339G	67	5.338G	68	5.537G
69	5.340G	70	5.659G	71	5.263G	72	5.431G
73	5.258G	74	5.390G	75	5.365G	76	5.441G
77	5.327G	78	5.564G	79	5.634G	80	5.454G
81	5.568G	82	5.652G	83	5.291G	84	5.626G
85	5.295G	86	5.500G	87	5.410G	88	5.528G
89	5.267G	90	5.396G	91	5.517G	92	5.329G
93	5.432G	94	5.697G	95	5.343G	96	5.461G
97	5.572G	98	5.702G	99	5.701G	100	5.298G



A D T

Hopping Frequency Sequence Name: HOP_FREQ_SEQ_HT20_30							
SEQ#	Frequency (Hz)	SEQ#	Frequency (Hz)	SEQ#	Frequency (Hz)	SEQ#	Frequency (Hz)
1	5.259G	2	5.482G	3	5.405G	4	5.508G
5	5.680G	6	5.515G	7	5.387G	8	5.669G
9	5.566G	10	5.594G	11	5.444G	12	5.712G
13	5.276G	14	5.700G	15	5.573G	16	5.565G
17	5.413G	18	5.600G	19	5.472G	20	5.304G
21	5.479G	22	5.456G	23	5.436G	24	5.627G
25	5.668G	26	5.510G	27	5.465G	28	5.349G
29	5.370G	30	5.667G	31	5.531G	32	5.499G
33	5.369G	34	5.430G	35	5.335G	36	5.368G
37	5.713G	38	5.372G	39	5.568G	40	5.509G
41	5.548G	42	5.281G	43	5.523G	44	5.714G
45	5.650G	46	5.312G	47	5.475G	48	5.250G
49	5.403G	50	5.611G	51	5.537G	52	5.706G
53	5.258G	54	5.525G	55	5.303G	56	5.425G
57	5.649G	58	5.473G	59	5.604G	60	5.321G
61	5.469G	62	5.330G	63	5.266G	64	5.431G
65	5.685G	66	5.529G	67	5.684G	68	5.411G
69	5.502G	70	5.670G	71	5.342G	72	5.299G
73	5.543G	74	5.462G	75	5.720G	76	5.707G
77	5.655G	78	5.644G	79	5.440G	80	5.585G
81	5.377G	82	5.642G	83	5.672G	84	5.417G
85	5.501G	86	5.255G	87	5.488G	88	5.470G
89	5.555G	90	5.450G	91	5.602G	92	5.336G
93	5.395G	94	5.506G	95	5.307G	96	5.390G
97	5.671G	98	5.291G	99	5.461G	100	5.514G

Hopping Frequency Sequence Name: HOP_FREQ_SEQ_HT40_01							
SEQ#	Frequency (Hz)	SEQ#	Frequency (Hz)	SEQ#	Frequency (Hz)	SEQ#	Frequency (Hz)
1	5.692G	2	5.717G	3	5.613G	4	5.615G
5	5.468G	6	5.493G	7	5.328G	8	5.542G
9	5.324G	10	5.442G	11	5.416G	12	5.649G
13	5.403G	14	5.448G	15	5.379G	16	5.458G
17	5.500G	18	5.250G	19	5.714G	20	5.348G
21	5.581G	22	5.463G	23	5.271G	24	5.636G
25	5.426G	26	5.673G	27	5.566G	28	5.598G
29	5.346G	30	5.701G	31	5.323G	32	5.552G
33	5.371G	34	5.631G	35	5.543G	36	5.623G
37	5.719G	38	5.679G	39	5.568G	40	5.560G
41	5.420G	42	5.473G	43	5.612G	44	5.393G
45	5.301G	46	5.461G	47	5.375G	48	5.689G



A D T

49	5.546G	50	5.429G	51	5.723G	52	5.550G
53	5.488G	54	5.657G	55	5.380G	56	5.270G
57	5.513G	58	5.483G	59	5.711G	60	5.633G
61	5.364G	62	5.536G	63	5.284G	64	5.357G
65	5.360G	66	5.343G	67	5.430G	68	5.281G
69	5.706G	70	5.593G	71	5.269G	72	5.635G
73	5.619G	74	5.539G	75	5.322G	76	5.306G
77	5.478G	78	5.464G	79	5.257G	80	5.413G
81	5.484G	82	5.688G	83	5.376G	84	5.587G
85	5.369G	86	5.421G	87	5.279G	88	5.276G
89	5.366G	90	5.354G	91	5.358G	92	5.492G
93	5.545G	94	5.646G	95	5.509G	96	5.685G
97	5.392G	98	5.709G	99	5.567G	100	5.315G

Hopping Frequency Sequence Name: HOP_FREQ_SEQ_HT40_02							
SEQ#	Frequency (Hz)	SEQ#	Frequency (Hz)	SEQ#	Frequency (Hz)	SEQ#	Frequency (Hz)
1	5.376G	2	5.503G	3	5.573G	4	5.466G
5	5.412G	6	5.632G	7	5.608G	8	5.446G
9	5.377G	10	5.509G	11	5.459G	12	5.507G
13	5.618G	14	5.387G	15	5.554G	16	5.312G
17	5.368G	18	5.396G	19	5.703G	20	5.329G
21	5.323G	22	5.485G	23	5.545G	24	5.587G
25	5.654G	26	5.332G	27	5.294G	28	5.471G
29	5.395G	30	5.565G	31	5.709G	32	5.357G
33	5.629G	34	5.253G	35	5.365G	36	5.427G
37	5.517G	38	5.304G	39	5.337G	40	5.286G
41	5.473G	42	5.383G	43	5.527G	44	5.261G
45	5.352G	46	5.607G	47	5.274G	48	5.586G
49	5.278G	50	5.637G	51	5.547G	52	5.492G
53	5.717G	54	5.269G	55	5.675G	56	5.494G
57	5.598G	58	5.670G	59	5.589G	60	5.533G
61	5.698G	62	5.563G	63	5.532G	64	5.322G
65	5.684G	66	5.595G	67	5.712G	68	5.525G
69	5.569G	70	5.291G	71	5.476G	72	5.603G
73	5.590G	74	5.410G	75	5.423G	76	5.710G
77	5.444G	78	5.665G	79	5.362G	80	5.356G
81	5.400G	82	5.257G	83	5.369G	84	5.311G
85	5.255G	86	5.609G	87	5.421G	88	5.279G
89	5.409G	90	5.512G	91	5.519G	92	5.317G
93	5.667G	94	5.564G	95	5.258G	96	5.468G
97	5.349G	98	5.544G	99	5.511G	100	5.697G



A D T

Hopping Frequency Sequence Name: HOP_FREQ_SEQ_HT40_03							
SEQ#	Frequency (Hz)	SEQ#	Frequency (Hz)	SEQ#	Frequency (Hz)	SEQ#	Frequency (Hz)
1	5.546G	2	5.425G	3	5.342G	4	5.529G
5	5.461G	6	5.426G	7	5.489G	8	5.493G
9	5.630G	10	5.657G	11	5.428G	12	5.332G
13	5.382G	14	5.475G	15	5.325G	16	5.388G
17	5.323G	18	5.682G	19	5.621G	20	5.679G
21	5.269G	22	5.599G	23	5.530G	24	5.313G
25	5.547G	26	5.273G	27	5.427G	28	5.279G
29	5.542G	30	5.490G	31	5.416G	32	5.633G
33	5.404G	34	5.525G	35	5.590G	36	5.567G
37	5.671G	38	5.448G	39	5.584G	40	5.592G
41	5.602G	42	5.415G	43	5.620G	44	5.349G
45	5.473G	46	5.330G	47	5.651G	48	5.705G
49	5.507G	50	5.282G	51	5.307G	52	5.431G
53	5.654G	54	5.312G	55	5.674G	56	5.531G
57	5.631G	58	5.607G	59	5.331G	60	5.357G
61	5.354G	62	5.669G	63	5.387G	64	5.356G
65	5.256G	66	5.272G	67	5.419G	68	5.298G
69	5.304G	70	5.466G	71	5.476G	72	5.346G
73	5.564G	74	5.445G	75	5.403G	76	5.492G
77	5.458G	78	5.296G	79	5.367G	80	5.563G
81	5.457G	82	5.613G	83	5.577G	84	5.423G
85	5.550G	86	5.317G	87	5.632G	88	5.442G
89	5.541G	90	5.344G	91	5.484G	92	5.637G
93	5.675G	94	5.625G	95	5.666G	96	5.653G
97	5.624G	98	5.696G	99	5.508G	100	5.350G

Hopping Frequency Sequence Name: HOP_FREQ_SEQ_HT40_04							
SEQ#	Frequency (Hz)	SEQ#	Frequency (Hz)	SEQ#	Frequency (Hz)	SEQ#	Frequency (Hz)
1	5.423G	2	5.638G	3	5.498G	4	5.266G
5	5.458G	6	5.454G	7	5.303G	8	5.365G
9	5.706G	10	5.688G	11	5.716G	12	5.680G
13	5.285G	14	5.622G	15	5.611G	16	5.264G
17	5.408G	18	5.352G	19	5.287G	20	5.526G
21	5.514G	22	5.664G	23	5.340G	24	5.652G
25	5.468G	26	5.452G	27	5.701G	28	5.414G
29	5.500G	30	5.614G	31	5.633G	32	5.655G
33	5.460G	34	5.416G	35	5.634G	36	5.465G
37	5.681G	38	5.434G	39	5.421G	40	5.425G
41	5.563G	42	5.476G	43	5.582G	44	5.381G
45	5.471G	46	5.686G	47	5.560G	48	5.293G



A D T

49	5.436G	50	5.657G	51	5.480G	52	5.619G
53	5.580G	54	5.639G	55	5.341G	56	5.409G
57	5.631G	58	5.362G	59	5.376G	60	5.494G
61	5.667G	62	5.654G	63	5.589G	64	5.486G
65	5.380G	66	5.710G	67	5.678G	68	5.467G
69	5.602G	70	5.581G	71	5.604G	72	5.691G
73	5.530G	74	5.576G	75	5.679G	76	5.644G
77	5.456G	78	5.429G	79	5.641G	80	5.451G
81	5.383G	82	5.407G	83	5.349G	84	5.519G
85	5.594G	86	5.700G	87	5.433G	88	5.299G
89	5.411G	90	5.646G	91	5.624G	92	5.373G
93	5.501G	94	5.490G	95	5.474G	96	5.525G
97	5.647G	98	5.718G	99	5.444G	100	5.258G

Hopping Frequency Sequence Name: HOP_FREQ_SEQ_HT40_05							
SEQ#	Frequency (Hz)	SEQ#	Frequency (Hz)	SEQ#	Frequency (Hz)	SEQ#	Frequency (Hz)
1	5.314G	2	5.263G	3	5.464G	4	5.519G
5	5.501G	6	5.352G	7	5.698G	8	5.508G
9	5.420G	10	5.387G	11	5.296G	12	5.329G
13	5.563G	14	5.264G	15	5.513G	16	5.520G
17	5.676G	18	5.368G	19	5.524G	20	5.412G
21	5.403G	22	5.261G	23	5.485G	24	5.397G
25	5.720G	26	5.690G	27	5.510G	28	5.597G
29	5.394G	30	5.444G	31	5.691G	32	5.620G
33	5.297G	34	5.724G	35	5.500G	36	5.273G
37	5.388G	38	5.332G	39	5.460G	40	5.542G
41	5.425G	42	5.618G	43	5.609G	44	5.482G
45	5.493G	46	5.717G	47	5.611G	48	5.521G
49	5.503G	50	5.406G	51	5.539G	52	5.327G
53	5.480G	54	5.534G	55	5.287G	56	5.324G
57	5.470G	58	5.365G	59	5.401G	60	5.696G
61	5.511G	62	5.344G	63	5.358G	64	5.373G
65	5.385G	66	5.325G	67	5.289G	68	5.722G
69	5.437G	70	5.281G	71	5.317G	72	5.447G
73	5.430G	74	5.484G	75	5.453G	76	5.499G
77	5.463G	78	5.678G	79	5.693G	80	5.294G
81	5.476G	82	5.636G	83	5.295G	84	5.687G
85	5.661G	86	5.694G	87	5.680G	88	5.704G
89	5.669G	90	5.713G	91	5.619G	92	5.712G
93	5.350G	94	5.312G	95	5.573G	96	5.709G
97	5.275G	98	5.496G	99	5.550G	100	5.641G



A D T

Hopping Frequency Sequence Name: HOP_FREQ_SEQ_HT40_06							
SEQ#	Frequency (Hz)	SEQ#	Frequency (Hz)	SEQ#	Frequency (Hz)	SEQ#	Frequency (Hz)
1	5.622G	2	5.545G	3	5.379G	4	5.597G
5	5.460G	6	5.570G	7	5.396G	8	5.676G
9	5.286G	10	5.510G	11	5.450G	12	5.257G
13	5.398G	14	5.439G	15	5.463G	16	5.438G
17	5.639G	18	5.568G	19	5.618G	20	5.381G
21	5.722G	22	5.330G	23	5.691G	24	5.345G
25	5.539G	26	5.670G	27	5.715G	28	5.293G
29	5.651G	30	5.708G	31	5.526G	32	5.335G
33	5.321G	34	5.665G	35	5.493G	36	5.647G
37	5.602G	38	5.454G	39	5.346G	40	5.285G
41	5.310G	42	5.707G	43	5.369G	44	5.632G
45	5.547G	46	5.432G	47	5.273G	48	5.489G
49	5.517G	50	5.542G	51	5.433G	52	5.683G
53	5.338G	54	5.443G	55	5.506G	56	5.325G
57	5.275G	58	5.650G	59	5.408G	60	5.701G
61	5.459G	62	5.574G	63	5.348G	64	5.307G
65	5.502G	66	5.684G	67	5.260G	68	5.523G
69	5.518G	70	5.397G	71	5.393G	72	5.495G
73	5.598G	74	5.712G	75	5.507G	76	5.663G
77	5.436G	78	5.486G	79	5.323G	80	5.661G
81	5.640G	82	5.299G	83	5.560G	84	5.410G
85	5.266G	86	5.521G	87	5.558G	88	5.617G
89	5.342G	90	5.565G	91	5.403G	92	5.297G
93	5.569G	94	5.575G	95	5.648G	96	5.556G
97	5.483G	98	5.418G	99	5.404G	100	5.405G

Hopping Frequency Sequence Name: HOP_FREQ_SEQ_HT40_07							
SEQ#	Frequency (Hz)	SEQ#	Frequency (Hz)	SEQ#	Frequency (Hz)	SEQ#	Frequency (Hz)
1	5.421G	2	5.681G	3	5.362G	4	5.622G
5	5.557G	6	5.568G	7	5.292G	8	5.607G
9	5.513G	10	5.613G	11	5.718G	12	5.687G
13	5.537G	14	5.484G	15	5.662G	16	5.597G
17	5.614G	18	5.579G	19	5.267G	20	5.516G
21	5.420G	22	5.713G	23	5.338G	24	5.327G
25	5.559G	26	5.635G	27	5.705G	28	5.620G
29	5.465G	30	5.376G	31	5.487G	32	5.498G
33	5.538G	34	5.671G	35	5.540G	36	5.321G
37	5.476G	38	5.467G	39	5.556G	40	5.624G
41	5.501G	42	5.642G	43	5.339G	44	5.440G
45	5.308G	46	5.609G	47	5.346G	48	5.438G



A D T

49	5.585G	50	5.270G	51	5.531G	52	5.264G
53	5.377G	54	5.273G	55	5.411G	56	5.454G
57	5.468G	58	5.374G	59	5.529G	60	5.457G
61	5.302G	62	5.595G	63	5.508G	64	5.365G
65	5.353G	66	5.357G	67	5.347G	68	5.427G
69	5.674G	70	5.494G	71	5.437G	72	5.633G
73	5.527G	74	5.590G	75	5.309G	76	5.603G
77	5.592G	78	5.632G	79	5.567G	80	5.392G
81	5.381G	82	5.690G	83	5.320G	84	5.463G
85	5.692G	86	5.488G	87	5.480G	88	5.424G
89	5.444G	90	5.294G	91	5.317G	92	5.470G
93	5.291G	94	5.615G	95	5.301G	96	5.368G
97	5.481G	98	5.669G	99	5.299G	100	5.599G

Hopping Frequency Sequence Name: HOP_FREQ_SEQ_HT40_08							
SEQ#	Frequency (Hz)	SEQ#	Frequency (Hz)	SEQ#	Frequency (Hz)	SEQ#	Frequency (Hz)
1	5.660G	2	5.576G	3	5.465G	4	5.273G
5	5.459G	6	5.383G	7	5.349G	8	5.284G
9	5.322G	10	5.356G	11	5.539G	12	5.382G
13	5.389G	14	5.288G	15	5.556G	16	5.421G
17	5.272G	18	5.517G	19	5.574G	20	5.423G
21	5.723G	22	5.651G	23	5.467G	24	5.460G
25	5.345G	26	5.642G	27	5.600G	28	5.319G
29	5.552G	30	5.287G	31	5.454G	32	5.543G
33	5.292G	34	5.514G	35	5.614G	36	5.599G
37	5.461G	38	5.410G	39	5.685G	40	5.405G
41	5.722G	42	5.304G	43	5.474G	44	5.546G
45	5.563G	46	5.550G	47	5.360G	48	5.384G
49	5.350G	50	5.446G	51	5.553G	52	5.507G
53	5.401G	54	5.639G	55	5.700G	56	5.613G
57	5.516G	58	5.648G	59	5.693G	60	5.411G
61	5.484G	62	5.492G	63	5.261G	64	5.413G
65	5.547G	66	5.324G	67	5.699G	68	5.544G
69	5.686G	70	5.377G	71	5.616G	72	5.309G
73	5.491G	74	5.257G	75	5.605G	76	5.307G
77	5.290G	78	5.269G	79	5.359G	80	5.707G
81	5.258G	82	5.711G	83	5.625G	84	5.714G
85	5.611G	86	5.531G	87	5.409G	88	5.458G
89	5.385G	90	5.582G	91	5.422G	92	5.271G
93	5.490G	94	5.523G	95	5.653G	96	5.289G
97	5.425G	98	5.391G	99	5.375G	100	5.577G



A D T

Hopping Frequency Sequence Name: HOP_FREQ_SEQ_HT40_09							
SEQ#	Frequency (Hz)	SEQ#	Frequency (Hz)	SEQ#	Frequency (Hz)	SEQ#	Frequency (Hz)
1	5.605G	2	5.427G	3	5.488G	4	5.461G
5	5.298G	6	5.478G	7	5.250G	8	5.641G
9	5.648G	10	5.596G	11	5.371G	12	5.696G
13	5.607G	14	5.590G	15	5.513G	16	5.380G
17	5.423G	18	5.604G	19	5.516G	20	5.711G
21	5.406G	22	5.664G	23	5.389G	24	5.440G
25	5.397G	26	5.687G	27	5.668G	28	5.444G
29	5.634G	30	5.501G	31	5.422G	32	5.268G
33	5.261G	34	5.290G	35	5.441G	36	5.572G
37	5.653G	38	5.315G	39	5.606G	40	5.546G
41	5.489G	42	5.588G	43	5.493G	44	5.551G
45	5.360G	46	5.597G	47	5.637G	48	5.424G
49	5.410G	50	5.408G	51	5.331G	52	5.326G
53	5.321G	54	5.446G	55	5.503G	56	5.384G
57	5.373G	58	5.681G	59	5.621G	60	5.363G
61	5.304G	62	5.585G	63	5.401G	64	5.309G
65	5.525G	66	5.425G	67	5.350G	68	5.302G
69	5.682G	70	5.276G	71	5.286G	72	5.543G
73	5.443G	74	5.472G	75	5.574G	76	5.676G
77	5.260G	78	5.296G	79	5.691G	80	5.655G
81	5.417G	82	5.504G	83	5.693G	84	5.575G
85	5.567G	86	5.620G	87	5.586G	88	5.334G
89	5.263G	90	5.254G	91	5.262G	92	5.375G
93	5.592G	94	5.570G	95	5.450G	96	5.534G
97	5.434G	98	5.287G	99	5.723G	100	5.333G

Hopping Frequency Sequence Name: HOP_FREQ_SEQ_HT40_10							
SEQ#	Frequency (Hz)	SEQ#	Frequency (Hz)	SEQ#	Frequency (Hz)	SEQ#	Frequency (Hz)
1	5.483G	2	5.642G	3	5.610G	4	5.384G
5	5.664G	6	5.303G	7	5.690G	8	5.299G
9	5.454G	10	5.578G	11	5.599G	12	5.706G
13	5.709G	14	5.392G	15	5.712G	16	5.340G
17	5.557G	18	5.616G	19	5.398G	20	5.336G
21	5.379G	22	5.682G	23	5.659G	24	5.598G
25	5.441G	26	5.443G	27	5.623G	28	5.451G
29	5.559G	30	5.524G	31	5.369G	32	5.492G
33	5.635G	34	5.393G	35	5.459G	36	5.375G
37	5.534G	38	5.596G	39	5.631G	40	5.311G
41	5.536G	42	5.683G	43	5.641G	44	5.429G
45	5.445G	46	5.670G	47	5.263G	48	5.260G



A D T

49	5.331G	50	5.630G	51	5.722G	52	5.707G
53	5.302G	54	5.323G	55	5.390G	56	5.371G
57	5.636G	58	5.417G	59	5.602G	60	5.306G
61	5.543G	62	5.420G	63	5.525G	64	5.554G
65	5.537G	66	5.475G	67	5.488G	68	5.258G
69	5.552G	70	5.333G	71	5.713G	72	5.446G
73	5.703G	74	5.553G	75	5.608G	76	5.704G
77	5.681G	78	5.565G	79	5.282G	80	5.396G
81	5.448G	82	5.373G	83	5.430G	84	5.676G
85	5.720G	86	5.414G	87	5.293G	88	5.425G
89	5.275G	90	5.612G	91	5.252G	92	5.406G
93	5.319G	94	5.584G	95	5.480G	96	5.370G
97	5.595G	98	5.699G	99	5.628G	100	5.256G

Hopping Frequency Sequence Name: HOP_FREQ_SEQ_HT40_11							
SEQ#	Frequency (Hz)	SEQ#	Frequency (Hz)	SEQ#	Frequency (Hz)	SEQ#	Frequency (Hz)
1	5.611G	2	5.456G	3	5.552G	4	5.683G
5	5.396G	6	5.724G	7	5.445G	8	5.312G
9	5.540G	10	5.454G	11	5.631G	12	5.635G
13	5.599G	14	5.387G	15	5.691G	16	5.370G
17	5.414G	18	5.281G	19	5.393G	20	5.444G
21	5.662G	22	5.366G	23	5.389G	24	5.250G
25	5.719G	26	5.715G	27	5.324G	28	5.384G
29	5.261G	30	5.467G	31	5.507G	32	5.375G
33	5.529G	34	5.700G	35	5.610G	36	5.609G
37	5.575G	38	5.358G	39	5.655G	40	5.502G
41	5.614G	42	5.287G	43	5.300G	44	5.578G
45	5.594G	46	5.339G	47	5.288G	48	5.556G
49	5.504G	50	5.272G	51	5.647G	52	5.251G
53	5.602G	54	5.412G	55	5.376G	56	5.267G
57	5.318G	58	5.325G	59	5.439G	60	5.543G
61	5.517G	62	5.656G	63	5.252G	64	5.419G
65	5.593G	66	5.453G	67	5.684G	68	5.485G
69	5.574G	70	5.257G	71	5.345G	72	5.291G
73	5.617G	74	5.402G	75	5.490G	76	5.435G
77	5.544G	78	5.511G	79	5.522G	80	5.651G
81	5.279G	82	5.584G	83	5.436G	84	5.652G
85	5.269G	86	5.477G	87	5.516G	88	5.344G
89	5.262G	90	5.595G	91	5.383G	92	5.515G
93	5.541G	94	5.565G	95	5.675G	96	5.371G
97	5.542G	98	5.416G	99	5.369G	100	5.559G



A D T

Hopping Frequency Sequence Name: HOP_FREQ_SEQ_HT40_12

SEQ#	Frequency (Hz)	SEQ#	Frequency (Hz)	SEQ#	Frequency (Hz)	SEQ#	Frequency (Hz)
1	5.512G	2	5.493G	3	5.313G	4	5.467G
5	5.634G	6	5.324G	7	5.316G	8	5.357G
9	5.586G	10	5.715G	11	5.359G	12	5.296G
13	5.615G	14	5.697G	15	5.279G	16	5.621G
17	5.464G	18	5.304G	19	5.680G	20	5.379G
21	5.499G	22	5.302G	23	5.695G	24	5.256G
25	5.457G	26	5.410G	27	5.508G	28	5.662G
29	5.723G	30	5.717G	31	5.577G	32	5.255G
33	5.639G	34	5.674G	35	5.398G	36	5.663G
37	5.714G	38	5.270G	39	5.607G	40	5.380G
41	5.694G	42	5.415G	43	5.442G	44	5.482G
45	5.546G	46	5.556G	47	5.362G	48	5.558G
49	5.524G	50	5.510G	51	5.453G	52	5.721G
53	5.455G	54	5.412G	55	5.515G	56	5.439G
57	5.517G	58	5.319G	59	5.454G	60	5.619G
61	5.364G	62	5.308G	63	5.298G	64	5.468G
65	5.340G	66	5.641G	67	5.562G	68	5.495G
69	5.342G	70	5.705G	71	5.612G	72	5.566G
73	5.636G	74	5.394G	75	5.630G	76	5.580G
77	5.418G	78	5.328G	79	5.688G	80	5.374G
81	5.591G	82	5.438G	83	5.420G	84	5.616G
85	5.713G	86	5.470G	87	5.545G	88	5.687G
89	5.305G	90	5.437G	91	5.595G	92	5.707G
93	5.563G	94	5.322G	95	5.451G	96	5.709G
97	5.653G	98	5.483G	99	5.363G	100	5.609G

Hopping Frequency Sequence Name: HOP_FREQ_SEQ_HT40_13

SEQ#	Frequency (Hz)	SEQ#	Frequency (Hz)	SEQ#	Frequency (Hz)	SEQ#	Frequency (Hz)
1	5.327G	2	5.438G	3	5.546G	4	5.610G
5	5.431G	6	5.448G	7	5.702G	8	5.664G
9	5.659G	10	5.429G	11	5.374G	12	5.686G
13	5.510G	14	5.636G	15	5.275G	16	5.722G
17	5.407G	18	5.585G	19	5.335G	20	5.310G
21	5.522G	22	5.355G	23	5.699G	24	5.458G
25	5.488G	26	5.525G	27	5.293G	28	5.254G
29	5.379G	30	5.430G	31	5.693G	32	5.385G
33	5.502G	34	5.386G	35	5.452G	36	5.697G
37	5.410G	38	5.551G	39	5.346G	40	5.684G
41	5.360G	42	5.681G	43	5.506G	44	5.341G
45	5.666G	46	5.516G	47	5.634G	48	5.381G



A D T

49	5.276G	50	5.279G	51	5.493G	52	5.708G
53	5.602G	54	5.257G	55	5.406G	56	5.523G
57	5.267G	58	5.517G	59	5.603G	60	5.723G
61	5.282G	62	5.589G	63	5.378G	64	5.260G
65	5.687G	66	5.678G	67	5.537G	68	5.579G
69	5.656G	70	5.651G	71	5.650G	72	5.445G
73	5.351G	74	5.526G	75	5.628G	76	5.459G
77	5.518G	78	5.644G	79	5.611G	80	5.569G
81	5.672G	82	5.670G	83	5.467G	84	5.620G
85	5.653G	86	5.689G	87	5.627G	88	5.328G
89	5.465G	90	5.641G	91	5.482G	92	5.423G
93	5.476G	94	5.481G	95	5.712G	96	5.599G
97	5.484G	98	5.633G	99	5.617G	100	5.601G

Hopping Frequency Sequence Name: HOP_FREQ_SEQ_HT40_14							
SEQ#	Frequency (Hz)	SEQ#	Frequency (Hz)	SEQ#	Frequency (Hz)	SEQ#	Frequency (Hz)
1	5.681G	2	5.612G	3	5.455G	4	5.489G
5	5.520G	6	5.375G	7	5.533G	8	5.536G
9	5.530G	10	5.457G	11	5.309G	12	5.566G
13	5.558G	14	5.393G	15	5.388G	16	5.408G
17	5.395G	18	5.675G	19	5.280G	20	5.593G
21	5.394G	22	5.262G	23	5.548G	24	5.259G
25	5.282G	26	5.705G	27	5.564G	28	5.600G
29	5.496G	30	5.378G	31	5.303G	32	5.373G
33	5.614G	34	5.364G	35	5.413G	36	5.700G
37	5.507G	38	5.449G	39	5.521G	40	5.418G
41	5.630G	42	5.471G	43	5.607G	44	5.485G
45	5.428G	46	5.365G	47	5.290G	48	5.438G
49	5.472G	50	5.662G	51	5.715G	52	5.347G
53	5.559G	54	5.286G	55	5.383G	56	5.466G
57	5.321G	58	5.389G	59	5.516G	60	5.490G
61	5.351G	62	5.580G	63	5.433G	64	5.546G
65	5.305G	66	5.642G	67	5.461G	68	5.563G
69	5.648G	70	5.721G	71	5.481G	72	5.582G
73	5.423G	74	5.606G	75	5.341G	76	5.579G
77	5.358G	78	5.340G	79	5.510G	80	5.572G
81	5.430G	82	5.476G	83	5.469G	84	5.325G
85	5.277G	86	5.658G	87	5.583G	88	5.676G
89	5.632G	90	5.439G	91	5.336G	92	5.634G
93	5.400G	94	5.650G	95	5.354G	96	5.441G
97	5.414G	98	5.492G	99	5.714G	100	5.369G



A D T

Hopping Frequency Sequence Name: HOP_FREQ_SEQ_HT40_15

SEQ#	Frequency (Hz)	SEQ#	Frequency (Hz)	SEQ#	Frequency (Hz)	SEQ#	Frequency (Hz)
1	5.459G	2	5.517G	3	5.509G	4	5.656G
5	5.416G	6	5.710G	7	5.633G	8	5.587G
9	5.346G	10	5.620G	11	5.350G	12	5.445G
13	5.481G	14	5.409G	15	5.692G	16	5.659G
17	5.684G	18	5.583G	19	5.391G	20	5.687G
21	5.492G	22	5.299G	23	5.373G	24	5.463G
25	5.723G	26	5.402G	27	5.542G	28	5.351G
29	5.298G	30	5.294G	31	5.340G	32	5.398G
33	5.689G	34	5.257G	35	5.377G	36	5.513G
37	5.372G	38	5.711G	39	5.375G	40	5.566G
41	5.424G	42	5.612G	43	5.543G	44	5.511G
45	5.577G	46	5.671G	47	5.545G	48	5.712G
49	5.634G	50	5.567G	51	5.572G	52	5.305G
53	5.477G	54	5.610G	55	5.314G	56	5.645G
57	5.596G	58	5.720G	59	5.713G	60	5.413G
61	5.519G	62	5.721G	63	5.443G	64	5.382G
65	5.297G	66	5.353G	67	5.263G	68	5.338G
69	5.343G	70	5.383G	71	5.358G	72	5.367G
73	5.565G	74	5.595G	75	5.379G	76	5.480G
77	5.606G	78	5.277G	79	5.390G	80	5.688G
81	5.374G	82	5.493G	83	5.562G	84	5.648G
85	5.458G	86	5.563G	87	5.611G	88	5.400G
89	5.550G	90	5.661G	91	5.529G	92	5.312G
93	5.334G	94	5.551G	95	5.304G	96	5.330G
97	5.408G	98	5.524G	99	5.488G	100	5.499G

Hopping Frequency Sequence Name: HOP_FREQ_SEQ_HT40_16

SEQ#	Frequency (Hz)	SEQ#	Frequency (Hz)	SEQ#	Frequency (Hz)	SEQ#	Frequency (Hz)
1	5.433G	2	5.320G	3	5.628G	4	5.470G
5	5.411G	6	5.456G	7	5.260G	8	5.363G
9	5.592G	10	5.668G	11	5.317G	12	5.307G
13	5.473G	14	5.535G	15	5.425G	16	5.441G
17	5.285G	18	5.687G	19	5.650G	20	5.616G
21	5.467G	22	5.492G	23	5.627G	24	5.698G
25	5.713G	26	5.537G	27	5.624G	28	5.426G
29	5.622G	30	5.265G	31	5.533G	32	5.534G
33	5.345G	34	5.486G	35	5.631G	36	5.398G
37	5.280G	38	5.501G	39	5.271G	40	5.342G
41	5.675G	42	5.676G	43	5.479G	44	5.603G
45	5.451G	46	5.655G	47	5.278G	48	5.605G



A D T

49	5.567G	50	5.333G	51	5.664G	52	5.708G
53	5.384G	54	5.484G	55	5.444G	56	5.614G
57	5.360G	58	5.469G	59	5.367G	60	5.268G
61	5.611G	62	5.250G	63	5.619G	64	5.328G
65	5.637G	66	5.563G	67	5.335G	68	5.575G
69	5.406G	70	5.548G	71	5.287G	72	5.717G
73	5.557G	74	5.712G	75	5.288G	76	5.475G
77	5.706G	78	5.283G	79	5.302G	80	5.488G
81	5.639G	82	5.290G	83	5.308G	84	5.413G
85	5.690G	86	5.435G	87	5.625G	88	5.279G
89	5.291G	90	5.437G	91	5.691G	92	5.315G
93	5.709G	94	5.397G	95	5.344G	96	5.296G
97	5.253G	98	5.700G	99	5.452G	100	5.577G

Hopping Frequency Sequence Name: HOP_FREQ_SEQ_HT40_17							
SEQ#	Frequency (Hz)	SEQ#	Frequency (Hz)	SEQ#	Frequency (Hz)	SEQ#	Frequency (Hz)
1	5.644G	2	5.392G	3	5.560G	4	5.293G
5	5.523G	6	5.515G	7	5.518G	8	5.352G
9	5.613G	10	5.277G	11	5.572G	12	5.482G
13	5.301G	14	5.264G	15	5.320G	16	5.329G
17	5.378G	18	5.708G	19	5.531G	20	5.291G
21	5.289G	22	5.408G	23	5.509G	24	5.661G
25	5.279G	26	5.642G	27	5.367G	28	5.270G
29	5.374G	30	5.423G	31	5.414G	32	5.627G
33	5.599G	34	5.267G	35	5.499G	36	5.501G
37	5.456G	38	5.675G	39	5.578G	40	5.442G
41	5.272G	42	5.432G	43	5.581G	44	5.682G
45	5.689G	46	5.450G	47	5.418G	48	5.331G
49	5.349G	50	5.591G	51	5.252G	52	5.525G
53	5.379G	54	5.342G	55	5.466G	56	5.649G
57	5.609G	58	5.375G	59	5.519G	60	5.656G
61	5.310G	62	5.261G	63	5.713G	64	5.384G
65	5.629G	66	5.588G	67	5.488G	68	5.704G
69	5.382G	70	5.427G	71	5.416G	72	5.477G
73	5.720G	74	5.711G	75	5.309G	76	5.665G
77	5.391G	78	5.250G	79	5.639G	80	5.701G
81	5.667G	82	5.547G	83	5.346G	84	5.260G
85	5.559G	86	5.461G	87	5.500G	88	5.465G
89	5.604G	90	5.415G	91	5.341G	92	5.288G
93	5.473G	94	5.258G	95	5.617G	96	5.687G
97	5.355G	98	5.685G	99	5.469G	100	5.368G



A D T

Hopping Frequency Sequence Name: HOP_FREQ_SEQ_HT40_18

SEQ#	Frequency (Hz)	SEQ#	Frequency (Hz)	SEQ#	Frequency (Hz)	SEQ#	Frequency (Hz)
1	5.369G	2	5.524G	3	5.453G	4	5.310G
5	5.272G	6	5.474G	7	5.533G	8	5.603G
9	5.473G	10	5.568G	11	5.433G	12	5.290G
13	5.353G	14	5.343G	15	5.437G	16	5.377G
17	5.679G	18	5.431G	19	5.313G	20	5.259G
21	5.582G	22	5.354G	23	5.614G	24	5.262G
25	5.523G	26	5.598G	27	5.556G	28	5.537G
29	5.555G	30	5.589G	31	5.328G	32	5.499G
33	5.660G	34	5.618G	35	5.344G	36	5.713G
37	5.267G	38	5.371G	39	5.337G	40	5.298G
41	5.571G	42	5.705G	43	5.677G	44	5.622G
45	5.422G	46	5.650G	47	5.633G	48	5.592G
49	5.634G	50	5.609G	51	5.289G	52	5.698G
53	5.416G	54	5.335G	55	5.383G	56	5.521G
57	5.459G	58	5.464G	59	5.309G	60	5.392G
61	5.541G	62	5.338G	63	5.561G	64	5.388G
65	5.358G	66	5.714G	67	5.670G	68	5.395G
69	5.515G	70	5.432G	71	5.312G	72	5.283G
73	5.511G	74	5.588G	75	5.577G	76	5.496G
77	5.708G	78	5.282G	79	5.695G	80	5.379G
81	5.454G	82	5.250G	83	5.317G	84	5.538G
85	5.403G	86	5.279G	87	5.724G	88	5.441G
89	5.325G	90	5.373G	91	5.254G	92	5.331G
93	5.488G	94	5.481G	95	5.389G	96	5.718G
97	5.351G	98	5.490G	99	5.390G	100	5.638G

Hopping Frequency Sequence Name: HOP_FREQ_SEQ_HT40_19

SEQ#	Frequency (Hz)	SEQ#	Frequency (Hz)	SEQ#	Frequency (Hz)	SEQ#	Frequency (Hz)
1	5.272G	2	5.352G	3	5.314G	4	5.687G
5	5.455G	6	5.266G	7	5.297G	8	5.362G
9	5.709G	10	5.292G	11	5.253G	12	5.321G
13	5.273G	14	5.663G	15	5.621G	16	5.293G
17	5.525G	18	5.419G	19	5.635G	20	5.530G
21	5.354G	22	5.548G	23	5.251G	24	5.412G
25	5.284G	26	5.409G	27	5.631G	28	5.399G
29	5.252G	30	5.446G	31	5.626G	32	5.681G
33	5.417G	34	5.529G	35	5.349G	36	5.491G
37	5.638G	38	5.506G	39	5.440G	40	5.344G
41	5.457G	42	5.434G	43	5.694G	44	5.264G
45	5.338G	46	5.489G	47	5.487G	48	5.573G



A D T

49	5.461G	50	5.410G	51	5.516G	52	5.559G
53	5.341G	54	5.588G	55	5.496G	56	5.517G
57	5.637G	58	5.701G	59	5.413G	60	5.584G
61	5.448G	62	5.533G	63	5.437G	64	5.334G
65	5.609G	66	5.324G	67	5.707G	68	5.335G
69	5.339G	70	5.632G	71	5.667G	72	5.310G
73	5.356G	74	5.563G	75	5.269G	76	5.664G
77	5.503G	78	5.617G	79	5.715G	80	5.562G
81	5.536G	82	5.401G	83	5.659G	84	5.645G
85	5.524G	86	5.535G	87	5.265G	88	5.442G
89	5.260G	90	5.490G	91	5.288G	92	5.505G
93	5.566G	94	5.595G	95	5.308G	96	5.435G
97	5.464G	98	5.454G	99	5.550G	100	5.418G

Hopping Frequency Sequence Name: HOP_FREQ_SEQ_HT40_20							
SEQ#	Frequency (Hz)	SEQ#	Frequency (Hz)	SEQ#	Frequency (Hz)	SEQ#	Frequency (Hz)
1	5.704G	2	5.593G	3	5.536G	4	5.282G
5	5.616G	6	5.605G	7	5.649G	8	5.423G
9	5.361G	10	5.419G	11	5.666G	12	5.487G
13	5.465G	14	5.655G	15	5.656G	16	5.663G
17	5.678G	18	5.391G	19	5.458G	20	5.400G
21	5.516G	22	5.613G	23	5.672G	24	5.675G
25	5.401G	26	5.425G	27	5.555G	28	5.435G
29	5.707G	30	5.529G	31	5.553G	32	5.577G
33	5.578G	34	5.359G	35	5.690G	36	5.539G
37	5.654G	38	5.548G	39	5.697G	40	5.328G
41	5.604G	42	5.705G	43	5.607G	44	5.511G
45	5.292G	46	5.687G	47	5.326G	48	5.376G
49	5.377G	50	5.279G	51	5.708G	52	5.455G
53	5.428G	54	5.310G	55	5.265G	56	5.646G
57	5.263G	58	5.701G	59	5.575G	60	5.566G
61	5.348G	62	5.332G	63	5.471G	64	5.352G
65	5.551G	66	5.521G	67	5.501G	68	5.537G
69	5.424G	70	5.590G	71	5.652G	72	5.635G
73	5.580G	74	5.660G	75	5.444G	76	5.283G
77	5.527G	78	5.619G	79	5.313G	80	5.257G
81	5.680G	82	5.589G	83	5.460G	84	5.583G
85	5.298G	86	5.535G	87	5.468G	88	5.662G
89	5.579G	90	5.262G	91	5.286G	92	5.269G
93	5.661G	94	5.650G	95	5.509G	96	5.657G
97	5.329G	98	5.615G	99	5.679G	100	5.275G



A D T

Hopping Frequency Sequence Name: HOP_FREQ_SEQ_HT40_21							
SEQ#	Frequency (Hz)	SEQ#	Frequency (Hz)	SEQ#	Frequency (Hz)	SEQ#	Frequency (Hz)
1	5.332G	2	5.255G	3	5.329G	4	5.304G
5	5.551G	6	5.624G	7	5.548G	8	5.386G
9	5.654G	10	5.282G	11	5.305G	12	5.690G
13	5.412G	14	5.335G	15	5.268G	16	5.538G
17	5.449G	18	5.411G	19	5.525G	20	5.635G
21	5.649G	22	5.526G	23	5.626G	24	5.536G
25	5.559G	26	5.478G	27	5.295G	28	5.269G
29	5.505G	30	5.597G	31	5.373G	32	5.369G
33	5.593G	34	5.554G	35	5.278G	36	5.560G
37	5.632G	38	5.550G	39	5.302G	40	5.466G
41	5.584G	42	5.334G	43	5.553G	44	5.377G
45	5.472G	46	5.511G	47	5.477G	48	5.567G
49	5.400G	50	5.430G	51	5.290G	52	5.664G
53	5.571G	54	5.506G	55	5.464G	56	5.531G
57	5.271G	58	5.350G	59	5.299G	60	5.250G
61	5.594G	62	5.541G	63	5.512G	64	5.416G
65	5.619G	66	5.427G	67	5.581G	68	5.309G
69	5.580G	70	5.454G	71	5.681G	72	5.421G
73	5.634G	74	5.403G	75	5.557G	76	5.382G
77	5.600G	78	5.706G	79	5.645G	80	5.564G
81	5.263G	82	5.497G	83	5.428G	84	5.389G
85	5.451G	86	5.692G	87	5.322G	88	5.262G
89	5.317G	90	5.397G	91	5.401G	92	5.300G
93	5.546G	94	5.470G	95	5.289G	96	5.611G
97	5.610G	98	5.530G	99	5.631G	100	5.486G

Hopping Frequency Sequence Name: HOP_FREQ_SEQ_HT40_22							
SEQ#	Frequency (Hz)	SEQ#	Frequency (Hz)	SEQ#	Frequency (Hz)	SEQ#	Frequency (Hz)
1	5.582G	2	5.710G	3	5.687G	4	5.518G
5	5.298G	6	5.579G	7	5.411G	8	5.477G
9	5.355G	10	5.272G	11	5.495G	12	5.553G
13	5.479G	14	5.427G	15	5.280G	16	5.357G
17	5.612G	18	5.490G	19	5.593G	20	5.645G
21	5.624G	22	5.574G	23	5.284G	24	5.340G
25	5.521G	26	5.585G	27	5.438G	28	5.323G
29	5.442G	30	5.547G	31	5.613G	32	5.485G
33	5.389G	34	5.472G	35	5.526G	36	5.640G
37	5.326G	38	5.536G	39	5.395G	40	5.445G
41	5.504G	42	5.347G	43	5.310G	44	5.492G
45	5.556G	46	5.654G	47	5.320G	48	5.680G



A D T

49	5.515G	50	5.384G	51	5.630G	52	5.568G
53	5.418G	54	5.588G	55	5.422G	56	5.290G
57	5.430G	58	5.255G	59	5.464G	60	5.643G
61	5.417G	62	5.689G	63	5.558G	64	5.661G
65	5.449G	66	5.483G	67	5.435G	68	5.372G
69	5.503G	70	5.259G	71	5.279G	72	5.446G
73	5.437G	74	5.325G	75	5.520G	76	5.605G
77	5.529G	78	5.620G	79	5.657G	80	5.496G
81	5.522G	82	5.460G	83	5.674G	84	5.329G
85	5.459G	86	5.414G	87	5.686G	88	5.463G
89	5.468G	90	5.703G	91	5.594G	92	5.683G
93	5.461G	94	5.377G	95	5.277G	96	5.699G
97	5.658G	98	5.704G	99	5.283G	100	5.517G

Hopping Frequency Sequence Name: HOP_FREQ_SEQ_HT40_23							
SEQ#	Frequency (Hz)	SEQ#	Frequency (Hz)	SEQ#	Frequency (Hz)	SEQ#	Frequency (Hz)
1	5.454G	2	5.448G	3	5.406G	4	5.260G
5	5.422G	6	5.389G	7	5.431G	8	5.613G
9	5.657G	10	5.562G	11	5.707G	12	5.459G
13	5.671G	14	5.319G	15	5.508G	16	5.370G
17	5.668G	18	5.572G	19	5.718G	20	5.501G
21	5.656G	22	5.710G	23	5.285G	24	5.292G
25	5.299G	26	5.662G	27	5.437G	28	5.344G
29	5.357G	30	5.404G	31	5.293G	32	5.456G
33	5.504G	34	5.359G	35	5.440G	36	5.605G
37	5.382G	38	5.290G	39	5.439G	40	5.339G
41	5.262G	42	5.608G	43	5.500G	44	5.341G
45	5.449G	46	5.468G	47	5.447G	48	5.425G
49	5.686G	50	5.614G	51	5.466G	52	5.651G
53	5.565G	54	5.529G	55	5.486G	56	5.506G
57	5.253G	58	5.415G	59	5.396G	60	5.523G
61	5.412G	62	5.333G	63	5.628G	64	5.298G
65	5.349G	66	5.511G	67	5.351G	68	5.558G
69	5.272G	70	5.549G	71	5.410G	72	5.530G
73	5.343G	74	5.484G	75	5.348G	76	5.417G
77	5.552G	78	5.358G	79	5.649G	80	5.724G
81	5.430G	82	5.460G	83	5.307G	84	5.528G
85	5.386G	86	5.498G	87	5.542G	88	5.597G
89	5.485G	90	5.294G	91	5.669G	92	5.337G
93	5.268G	94	5.570G	95	5.296G	96	5.698G
97	5.401G	98	5.391G	99	5.619G	100	5.721G



A D T

Hopping Frequency Sequence Name: HOP_FREQ_SEQ_HT40_24							
SEQ#	Frequency (Hz)	SEQ#	Frequency (Hz)	SEQ#	Frequency (Hz)	SEQ#	Frequency (Hz)
1	5.591G	2	5.399G	3	5.481G	4	5.416G
5	5.516G	6	5.526G	7	5.440G	8	5.599G
9	5.617G	10	5.561G	11	5.573G	12	5.266G
13	5.392G	14	5.675G	15	5.277G	16	5.354G
17	5.639G	18	5.292G	19	5.262G	20	5.511G
21	5.683G	22	5.641G	23	5.523G	24	5.702G
25	5.372G	26	5.380G	27	5.313G	28	5.620G
29	5.420G	30	5.583G	31	5.361G	32	5.594G
33	5.664G	34	5.706G	35	5.580G	36	5.668G
37	5.427G	38	5.402G	39	5.711G	40	5.255G
41	5.317G	42	5.691G	43	5.593G	44	5.502G
45	5.656G	46	5.348G	47	5.696G	48	5.415G
49	5.604G	50	5.383G	51	5.306G	52	5.567G
53	5.559G	54	5.358G	55	5.655G	56	5.446G
57	5.708G	58	5.529G	59	5.587G	60	5.477G
61	5.273G	62	5.606G	63	5.462G	64	5.588G
65	5.278G	66	5.428G	67	5.330G	68	5.406G
69	5.469G	70	5.331G	71	5.433G	72	5.356G
73	5.281G	74	5.718G	75	5.431G	76	5.537G
77	5.471G	78	5.363G	79	5.271G	80	5.259G
81	5.425G	82	5.414G	83	5.343G	84	5.467G
85	5.288G	86	5.352G	87	5.315G	88	5.370G
89	5.677G	90	5.325G	91	5.556G	92	5.305G
93	5.301G	94	5.551G	95	5.250G	96	5.302G
97	5.700G	98	5.712G	99	5.643G	100	5.566G

Hopping Frequency Sequence Name: HOP_FREQ_SEQ_HT40_25							
SEQ#	Frequency (Hz)	SEQ#	Frequency (Hz)	SEQ#	Frequency (Hz)	SEQ#	Frequency (Hz)
1	5.541G	2	5.657G	3	5.405G	4	5.321G
5	5.282G	6	5.707G	7	5.498G	8	5.435G
9	5.327G	10	5.451G	11	5.558G	12	5.265G
13	5.310G	14	5.665G	15	5.340G	16	5.324G
17	5.402G	18	5.496G	19	5.400G	20	5.654G
21	5.311G	22	5.609G	23	5.637G	24	5.547G
25	5.414G	26	5.449G	27	5.702G	28	5.293G
29	5.452G	30	5.475G	31	5.306G	32	5.512G
33	5.369G	34	5.661G	35	5.261G	36	5.722G
37	5.570G	38	5.506G	39	5.326G	40	5.638G
41	5.278G	42	5.404G	43	5.421G	44	5.505G
45	5.515G	46	5.319G	47	5.681G	48	5.566G



A D T

49	5.511G	50	5.612G	51	5.429G	52	5.582G
53	5.450G	54	5.539G	55	5.480G	56	5.298G
57	5.594G	58	5.465G	59	5.290G	60	5.427G
61	5.296G	62	5.472G	63	5.523G	64	5.255G
65	5.628G	66	5.583G	67	5.357G	68	5.676G
69	5.569G	70	5.361G	71	5.288G	72	5.508G
73	5.425G	74	5.374G	75	5.699G	76	5.618G
77	5.256G	78	5.379G	79	5.453G	80	5.299G
81	5.538G	82	5.531G	83	5.647G	84	5.461G
85	5.678G	86	5.683G	87	5.448G	88	5.551G
89	5.315G	90	5.546G	91	5.724G	92	5.660G
93	5.671G	94	5.484G	95	5.325G	96	5.301G
97	5.410G	98	5.307G	99	5.560G	100	5.317G

Hopping Frequency Sequence Name: HOP_FREQ_SEQ_HT40_26							
SEQ#	Frequency (Hz)	SEQ#	Frequency (Hz)	SEQ#	Frequency (Hz)	SEQ#	Frequency (Hz)
1	5.328G	2	5.426G	3	5.695G	4	5.549G
5	5.444G	6	5.470G	7	5.539G	8	5.366G
9	5.304G	10	5.512G	11	5.404G	12	5.269G
13	5.259G	14	5.568G	15	5.258G	16	5.394G
17	5.685G	18	5.582G	19	5.556G	20	5.262G
21	5.257G	22	5.719G	23	5.585G	24	5.619G
25	5.718G	26	5.606G	27	5.369G	28	5.287G
29	5.457G	30	5.676G	31	5.412G	32	5.360G
33	5.649G	34	5.565G	35	5.396G	36	5.371G
37	5.471G	38	5.607G	39	5.579G	40	5.530G
41	5.276G	42	5.466G	43	5.467G	44	5.350G
45	5.320G	46	5.453G	47	5.395G	48	5.401G
49	5.267G	50	5.533G	51	5.610G	52	5.432G
53	5.635G	54	5.275G	55	5.552G	56	5.439G
57	5.410G	58	5.344G	59	5.349G	60	5.423G
61	5.698G	62	5.415G	63	5.321G	64	5.480G
65	5.309G	66	5.592G	67	5.252G	68	5.499G
69	5.544G	70	5.597G	71	5.587G	72	5.354G
73	5.603G	74	5.402G	75	5.272G	76	5.497G
77	5.292G	78	5.622G	79	5.337G	80	5.414G
81	5.387G	82	5.722G	83	5.388G	84	5.256G
85	5.498G	86	5.515G	87	5.600G	88	5.713G
89	5.345G	90	5.376G	91	5.348G	92	5.629G
93	5.605G	94	5.589G	95	5.422G	96	5.326G
97	5.357G	98	5.567G	99	5.576G	100	5.305G



A D T

Hopping Frequency Sequence Name: HOP_FREQ_SEQ_HT40_27

SEQ#	Frequency (Hz)	SEQ#	Frequency (Hz)	SEQ#	Frequency (Hz)	SEQ#	Frequency (Hz)
1	5.558G	2	5.511G	3	5.286G	4	5.314G
5	5.680G	6	5.614G	7	5.361G	8	5.423G
9	5.664G	10	5.599G	11	5.658G	12	5.620G
13	5.543G	14	5.722G	15	5.612G	16	5.544G
17	5.462G	18	5.393G	19	5.259G	20	5.360G
21	5.634G	22	5.373G	23	5.321G	24	5.422G
25	5.474G	26	5.255G	27	5.529G	28	5.701G
29	5.587G	30	5.718G	31	5.355G	32	5.553G
33	5.583G	34	5.489G	35	5.554G	36	5.312G
37	5.301G	38	5.661G	39	5.480G	40	5.254G
41	5.671G	42	5.716G	43	5.413G	44	5.683G
45	5.408G	46	5.724G	47	5.652G	48	5.346G
49	5.713G	50	5.440G	51	5.433G	52	5.385G
53	5.617G	54	5.699G	55	5.376G	56	5.663G
57	5.548G	58	5.478G	59	5.418G	60	5.272G
61	5.302G	62	5.498G	63	5.441G	64	5.675G
65	5.468G	66	5.390G	67	5.505G	68	5.555G
69	5.424G	70	5.666G	71	5.382G	72	5.464G
73	5.655G	74	5.654G	75	5.419G	76	5.586G
77	5.279G	78	5.337G	79	5.649G	80	5.298G
81	5.710G	82	5.300G	83	5.605G	84	5.534G
85	5.250G	86	5.487G	87	5.594G	88	5.545G
89	5.426G	90	5.673G	91	5.320G	92	5.537G
93	5.565G	94	5.488G	95	5.297G	96	5.589G
97	5.383G	98	5.593G	99	5.267G	100	5.381G

Hopping Frequency Sequence Name: HOP_FREQ_SEQ_HT40_28

SEQ#	Frequency (Hz)	SEQ#	Frequency (Hz)	SEQ#	Frequency (Hz)	SEQ#	Frequency (Hz)
1	5.275G	2	5.522G	3	5.283G	4	5.505G
5	5.444G	6	5.693G	7	5.662G	8	5.716G
9	5.363G	10	5.593G	11	5.469G	12	5.571G
13	5.397G	14	5.511G	15	5.721G	16	5.323G
17	5.403G	18	5.685G	19	5.574G	20	5.521G
21	5.669G	22	5.433G	23	5.405G	24	5.640G
25	5.576G	26	5.361G	27	5.452G	28	5.594G
29	5.553G	30	5.357G	31	5.606G	32	5.551G
33	5.708G	34	5.256G	35	5.290G	36	5.410G
37	5.257G	38	5.526G	39	5.501G	40	5.438G
41	5.647G	42	5.720G	43	5.466G	44	5.494G
45	5.278G	46	5.695G	47	5.306G	48	5.282G



A D T

49	5.261G	50	5.424G	51	5.482G	52	5.723G
53	5.395G	54	5.518G	55	5.472G	56	5.399G
57	5.547G	58	5.702G	59	5.530G	60	5.462G
61	5.620G	62	5.304G	63	5.354G	64	5.279G
65	5.317G	66	5.621G	67	5.595G	68	5.483G
69	5.252G	70	5.583G	71	5.380G	72	5.694G
73	5.607G	74	5.394G	75	5.629G	76	5.596G
77	5.613G	78	5.425G	79	5.414G	80	5.660G
81	5.627G	82	5.459G	83	5.415G	84	5.592G
85	5.578G	86	5.276G	87	5.604G	88	5.265G
89	5.682G	90	5.614G	91	5.332G	92	5.461G
93	5.681G	94	5.633G	95	5.417G	96	5.381G
97	5.542G	98	5.305G	99	5.272G	100	5.296G

Hopping Frequency Sequence Name: HOP_FREQ_SEQ_HT40_29							
SEQ#	Frequency (Hz)	SEQ#	Frequency (Hz)	SEQ#	Frequency (Hz)	SEQ#	Frequency (Hz)
1	5.344G	2	5.569G	3	5.451G	4	5.434G
5	5.379G	6	5.367G	7	5.318G	8	5.458G
9	5.583G	10	5.654G	11	5.463G	12	5.294G
13	5.286G	14	5.419G	15	5.269G	16	5.505G
17	5.380G	18	5.593G	19	5.600G	20	5.481G
21	5.663G	22	5.257G	23	5.527G	24	5.587G
25	5.297G	26	5.622G	27	5.440G	28	5.362G
29	5.391G	30	5.558G	31	5.614G	32	5.302G
33	5.591G	34	5.343G	35	5.700G	36	5.258G
37	5.420G	38	5.576G	39	5.595G	40	5.304G
41	5.386G	42	5.539G	43	5.687G	44	5.599G
45	5.396G	46	5.404G	47	5.636G	48	5.274G
49	5.541G	50	5.454G	51	5.348G	52	5.677G
53	5.282G	54	5.573G	55	5.621G	56	5.431G
57	5.668G	58	5.328G	59	5.255G	60	5.333G
61	5.368G	62	5.489G	63	5.271G	64	5.521G
65	5.691G	66	5.313G	67	5.660G	68	5.493G
69	5.260G	70	5.536G	71	5.506G	72	5.552G
73	5.695G	74	5.615G	75	5.525G	76	5.717G
77	5.433G	78	5.514G	79	5.608G	80	5.559G
81	5.472G	82	5.466G	83	5.457G	84	5.342G
85	5.547G	86	5.336G	87	5.395G	88	5.509G
89	5.388G	90	5.612G	91	5.401G	92	5.291G
93	5.364G	94	5.526G	95	5.516G	96	5.642G
97	5.346G	98	5.649G	99	5.376G	100	5.531G



A D T

Hopping Frequency Sequence Name: HOP_FREQ_SEQ_HT40_30							
SEQ#	Frequency (Hz)	SEQ#	Frequency (Hz)	SEQ#	Frequency (Hz)	SEQ#	Frequency (Hz)
1	5.359G	2	5.636G	3	5.406G	4	5.673G
5	5.629G	6	5.337G	7	5.302G	8	5.684G
9	5.670G	10	5.595G	11	5.564G	12	5.465G
13	5.259G	14	5.531G	15	5.379G	16	5.450G
17	5.279G	18	5.387G	19	5.642G	20	5.563G
21	5.442G	22	5.652G	23	5.538G	24	5.376G
25	5.422G	26	5.719G	27	5.498G	28	5.265G
29	5.319G	30	5.324G	31	5.340G	32	5.304G
33	5.609G	34	5.512G	35	5.698G	36	5.420G
37	5.475G	38	5.395G	39	5.547G	40	5.584G
41	5.640G	42	5.620G	43	5.664G	44	5.333G
45	5.708G	46	5.487G	47	5.502G	48	5.655G
49	5.481G	50	5.289G	51	5.385G	52	5.431G
53	5.455G	54	5.490G	55	5.539G	56	5.666G
57	5.417G	58	5.291G	59	5.364G	60	5.556G
61	5.522G	62	5.679G	63	5.365G	64	5.656G
65	5.402G	66	5.483G	67	5.250G	68	5.381G
69	5.536G	70	5.649G	71	5.516G	72	5.561G
73	5.418G	74	5.680G	75	5.390G	76	5.622G
77	5.596G	78	5.554G	79	5.258G	80	5.565G
81	5.662G	82	5.521G	83	5.489G	84	5.310G
85	5.469G	86	5.492G	87	5.298G	88	5.299G
89	5.702G	90	5.647G	91	5.631G	92	5.508G
93	5.704G	94	5.583G	95	5.458G	96	5.428G
97	5.352G	98	5.389G	99	5.586G	100	5.675G

10 APPENDIX-C

MASTER MODE

NOTCH BAND IN 5600-5650MHZ

Verify that the 5600 - 5650 MHz band is notched.
 Test results demonstrating last channel shall not exceed the band edge on 56000~5650MHz.

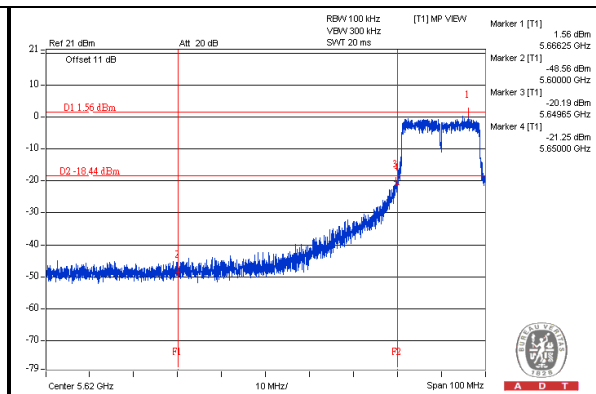
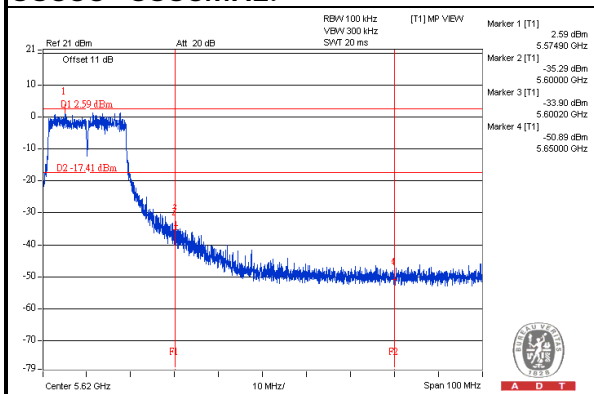

802.11n (20MHz) OFDM MODULATION (CH 116: 5580MHz)

802.11n (20MHz) OFDM MODULATION (CH 132: 5660MHz)

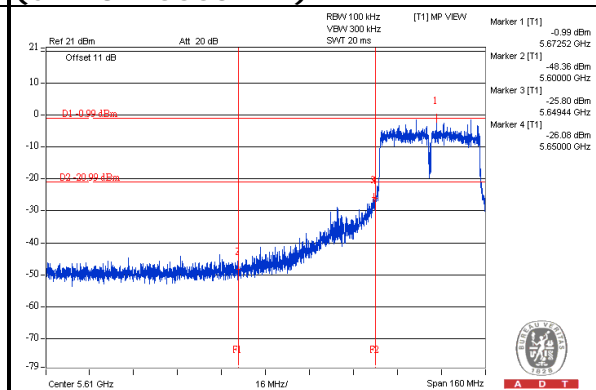
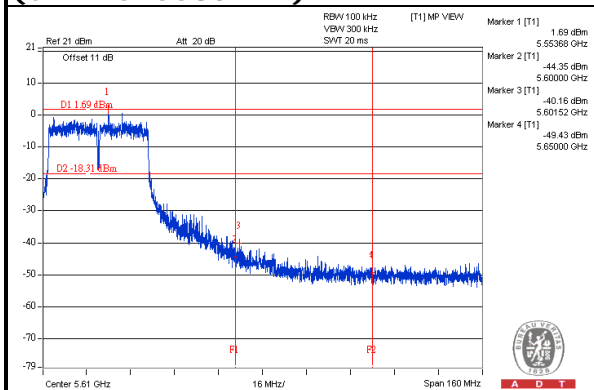

802.11n (40MHz) OFDM MODULATION (CH 110: 5550MHz)

802.11n (40MHz) OFDM MODULATION (CH 134: 5670MHz)

CLIENT MODE

NON BEACON ON DFS BAND

- 1) Test results demonstrating no any beacon on DFS band after power up.
- 2) Observation time is 10min after power up.

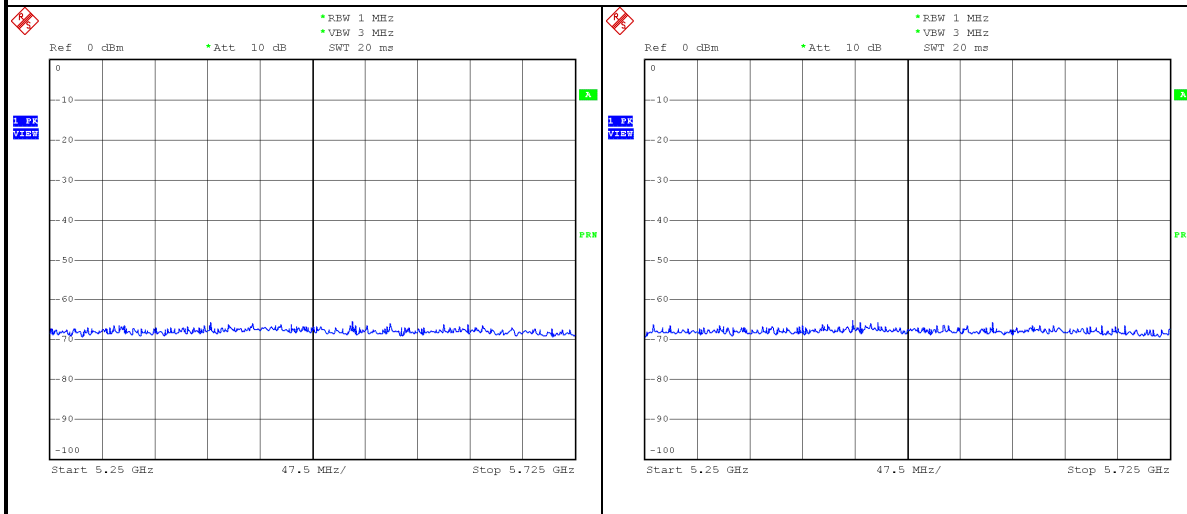

EUT (Client) links with master on 11n HT20 mode

EUT (Client) links with master on 11n HT40 mode

BAND EDGE AT NEARBY DFS BAND

- 1) Test results demonstrating last channel (20dB BW) shall not exceed the band edge on 5150~5250MHz.

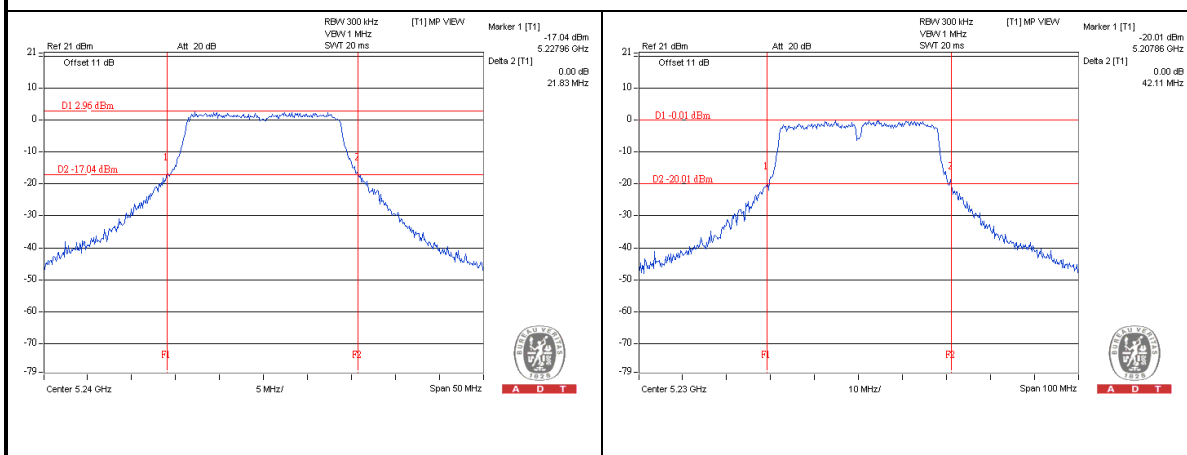

EUT (Client) links with master on 11n HT20 mode

EUT (Client) links with master on 11n HT40 mode

---END---