



## Test Report

Product Name : Wireless LAN PC Card

Model No.: WP210g

FCC ID.: PQP-WP210G

Applicant : PRIME ELECTRONICS & SATELLITICS INC.

Address : 69, Tung-Yuan Rd., Chung-Li Industrial Park, Chung-Li  
City, Taoyuan, Taiwan.

Date of Receipt : Aug 11, 2003

Date of Test : Aug 26, 2003

Report No. : 038H035FI

The test results relate only to the samples tested.

The test report shall not be reproduced except in full without the written approval of Quietek Corporation.

This report must not be used to claim product endorsement by NVLAP any agency of the U.S. Government

# Test Report Certification

Test Date : Aug 26, 2003

Report No. : 038H035FI



Accredited by NIST (NVLAP)

NVLAP Lab Code: 200347-0

Product Name : Wireless LAN PC Card

Applicant : PRIME ELECTRONICS & SATELLITICS INC.

Address : 69, Tung-Yuan Rd., Chung-Li Industrial Park,  
Chung-Li City, Taoyuan, Taiwan.

Manufacturer : PRIME ELECTRONICS & SATELLITICS INC.

Model No. : WP210g

FCC ID. : PQP-WP210G

Rated Voltage : DC 3.3V(Power by PC)

Trade Name : PESI

Measurement Standard : FCC Part 15 Subpart C Paragraph 15.247

Measurement Procedure : ANSI C63.4: 1992

Test Result : Complied



The Test Results relate only to the samples tested.

The test report shall not be reproduced except in full without the written approval of Quietek Corporation.

This report must not be used to claim product endorsement by NVLAP any agency of the U.S. Government

Documented By : \_\_\_\_\_  
( Lydia Tsai )

Tested By : \_\_\_\_\_  
( Ken Hsu )

Approved By : \_\_\_\_\_  
( Kevin Wang )

## TABLE OF CONTENTS

Description	Page
<b>1. GENERAL INFORMATION .....</b>	<b>5</b>
1.1. EUT Description.....	5
1.2. Operational Description .....	6
1.3. Tested System Details.....	7
1.4. Configuration of tested System .....	8
1.5. EUT Exercise Software .....	8
1.6. Test Facility .....	9
<b>2. Conducted Emission.....</b>	<b>10</b>
2.1. Test Equipment.....	10
2.2. Test Setup .....	10
2.3. Limits .....	10
2.4. Test Procedure .....	11
2.5. Test Result of Conducted Emission.....	12
<b>3. Peak Power Output .....</b>	<b>16</b>
3.1. Test Equipment.....	16
3.2. Test Setup .....	16
3.3. Limits .....	16
3.4. Test Result of Peak Power Output.....	17
<b>4. Radiated Emission.....</b>	<b>19</b>
4.1. Test Equipment.....	19
4.2. Test Setup .....	19
4.3. Limits .....	20
4.4. Test Procedure .....	20
4.5. Test Result of Radiated Emission.....	21
<b>5. Band Edge .....</b>	<b>33</b>
5.1. Test Equipment.....	33
5.2. Test Setup .....	34
5.3. Limits .....	35
5.4. Test Procedure .....	35
5.5. Test Result of Band Edge .....	36
<b>6. Occupied Bandwidth.....</b>	<b>40</b>
6.1. Test Equipment.....	40
6.2. Test Setup .....	40
6.3. Limits .....	40
6.4. Test Result of Occupied Bandwidth .....	41
<b>7. Power Density .....</b>	<b>43</b>
7.1. Test Equipment.....	43
7.2. Test Setup .....	43
7.3. Limits .....	43
7.4. Test Result of Power Density .....	44
<b>8. EMI Reduction Method During Compliance Testing .....</b>	<b>46</b>

Attachment 1: EUT Test Photographs

Attachment 2: EUT Detailed Photographs

## 1. GENERAL INFORMATION

### 1.1. EUT Description

Product Name : Wireless LAN PC Card  
 Trade Name : PESI  
 FCC ID. : PQP-WP210G  
 Model No. : WP210g  
 Frequency Range : 2412MHz to 2462MHz  
 Channel Number : 11  
 Data Speed (IEEE 802.11b) : 1Mbps, 2Mbps, 5.5Mbps, 11Mbps  
 Data Speed (IEEE 802.11g) : 6Mbps, 9Mbps, 12Mbps, 18Mbps, 24Mbps, 36Mbps,  
 48Mbps, 54Mbps  
 Type of Modulation : Direct Sequence Spread Spectrum  
 Antenna Type : Printed  
 Antenna Gain : 0dBi  
 Channel Control : Auto

Frequency of Each Channel:

Channel	Frequency	Channel	Frequency	Channel	Frequency
Channel 1:	2412 MHz	Channel 5:	2432 MHz	Channel 9:	2452 MHz
Channel 2:	2417 MHz	Channel 6:	2437 MHz	Channel 10:	2457 MHz
Channel 3:	2422 MHz	Channel 7:	2442 MHz	Channel 11:	2462 MHz
Channel 4:	2427 MHz	Channel 8:	2447 MHz		

Note:

1. This device is a 2.4GHz Wireless LAN PC Card included a 2.4GHz receiving function, a 2.4GHz transmitting function.
2. Regards to the frequency band operation; the highest rate that was included the lowest , middle and highest frequency of channel were selected to perform the test, then shown on this report.
3. These tests were conducted on a sample of the equipment for the purpose of demonstrating compliance with Part 15 Subpart C Paragraph 15.247 for spread spectrum devices.
4. This device is a composite device in accordance with Part 15 regulations. The function receiving was measured and made a test report that the report number is 038H035F under Declaration of Conformity.

## 1.2. Operational Description

EUT is a Wireless LAN PC Card with 11 channels. This device provided four kind of transmitting speed 1,2,5.5 and 11Mbps. The device of RF carrier is DQPSK, DB PSK and CCK(IEEE 802.11b) or eight kinds of transmitting speed 6, 9, 12, 18, 24, 36, 48 and 54Mbps, The device of RF carrier is OFDM(IEEE 802.11g).

The device adapts direct sequence spread spectrum modulation. The printed antenna was provides diversity function to improve the receiving function.

This Wireless LAN PC Card compliant with IEEE 802.11b and IEEE 802.11g is a high-efficiency Wireless LAN adapter. It allows your computer to connect to a wireless network and to share resources, such as files or printers without being bound to the network wires. Operation in 2.4GHz Direct Sequence Spread Spectrum (DSSS) radio transmission, the Wireless LAN PC Card Wired Equivalent Protection (WEP) algorithm is used. In addition, its standard compliance ensures that it can communicate with any 802.11b and IEEE 802.11g network.

### 1.3. Tested System Details

The types for all equipment, plus descriptions of all cables used in the tested system (including inserted cards) are:

	Product	Manufacturer	Model No.	Serial No.	Power Cord
(1)	Notebook PC	DELL	Latitude 610	N/A	Non-shielded, 1.7m, a ferrite core bonded
(2)	Monitor	SONY	PVM-14M2U	2018559	Non-shielded, 1.8m
(3)	Printer	HP	C2642A	TH86M1M34W	Non-shielded, 0.7m
(4)	Modem	ACEEX	DM-1414	0102027544	Non-shielded, 1.6m
(5)	Microphone & Earphone	TOKTO	SX-MI	N/A	--
(6)	Mouse	IBM	M-SAU-IBM6	23-029372	--
(7)	USB Mouse	Logitech	M-UE55	N/A	--
(8)	Notebook PC	DELL	Latitude 610	N/A	Non-shielded, 1.7m, a ferrite core bonded

Signal Cable Type	Signal cable Description
A. VGA Cable	Shielded, 1.6m, a ferrite core bonded.
B. Printer Cable	Shielded, 1.2m
C. Modem Cable	Non-Shielded, 1.5m
D. Microphone & Earphone Cable	Shielded, 1.8m
E. Mouse Cable	Shielded, 1.8m
F. USB Mouse Cable	Shielded, 1.0m

### 1.4. Configuration of tested System

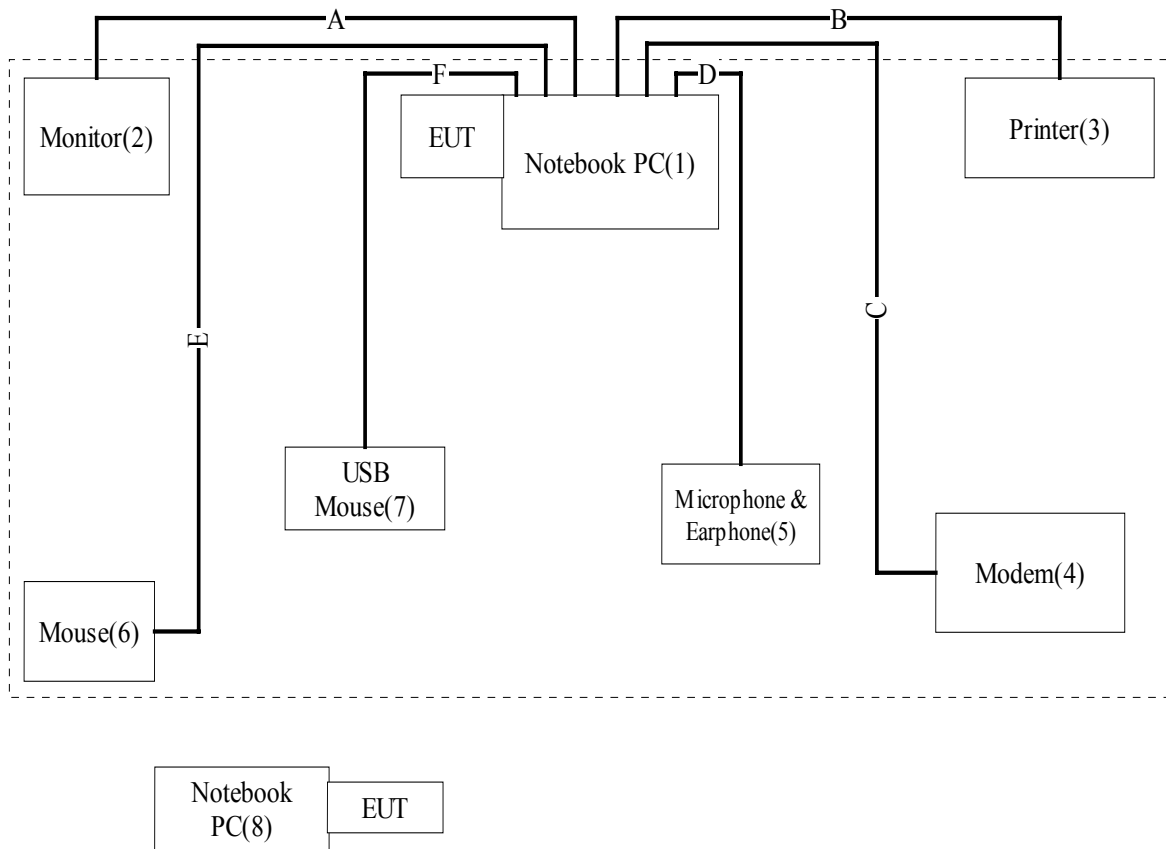

### 1.5. EUT Exercise Software

- (1) Setup the EUT and simulators as shown on 1.4
- (2) Turn on the power of all equipment.
- (3) Notebook PC reads data from disk.
- (4) Data will be transmitting through EUT.
- (5) The transmitted status will be shown on the monitor.
- (6) Repeat the above procedure 1.5.3 to 1.5.5



**1.6. Test Facility**

Ambient conditions in the laboratory:

Items	Required (IEC 68-1)	Actual
Temperature (°C)	15-35	20-35
Humidity (%RH)	25-75	50-65
Barometric pressure (mbar)	860-1060	950-1000

Site Description: November 3, 1998 File on  
 Federal Communications Commission  
 FCC Engineering Laboratory  
 7435 Oakland Mills Road  
 Columbia, MD 21046  
 Reference 31040/SIT1300F2  
 August 30, 2001 Accreditation on NVLAP  
 NVLAP Lab Code: 200347-0



Site Name: Quietek Corporation

Site Address: No.75-1, Wang-Yeh Valley, Yung-Hsing,  
 Chiung-Lin, Hsin-Chu County,  
 Taiwan, R.O.C.  
 TEL : 886-3-592-8858 / FAX : 886-3-592-8859  
 E-Mail: [service@quietek.com](mailto:service@quietek.com)

## 2. Conducted Emission

### 2.1. Test Equipment

The following test equipment are used during the test:

Item	Equipment	Manufacturer	Model No. / Serial No.	Last Cal.	Remark
1	Test Receiver	R & S	ESCS 30 / 825442/018	Sep., 2002	
2	Artificial Mains Network	R & S	ENV4200 / 848411/10	Feb., 2003	Peripherals
3	LISN	R & S	ESH3-Z5 / 825562/002	Feb., 2003	EUT
4	Pulse Limiter	R & S	ESH3-Z2 / 357.8810.52	Feb., 2003	
5	No.2 Shielded Room			N/A	

Note: All equipment upon which need to calibrated are with calibration period of 1 year.

### 2.2. Test Setup

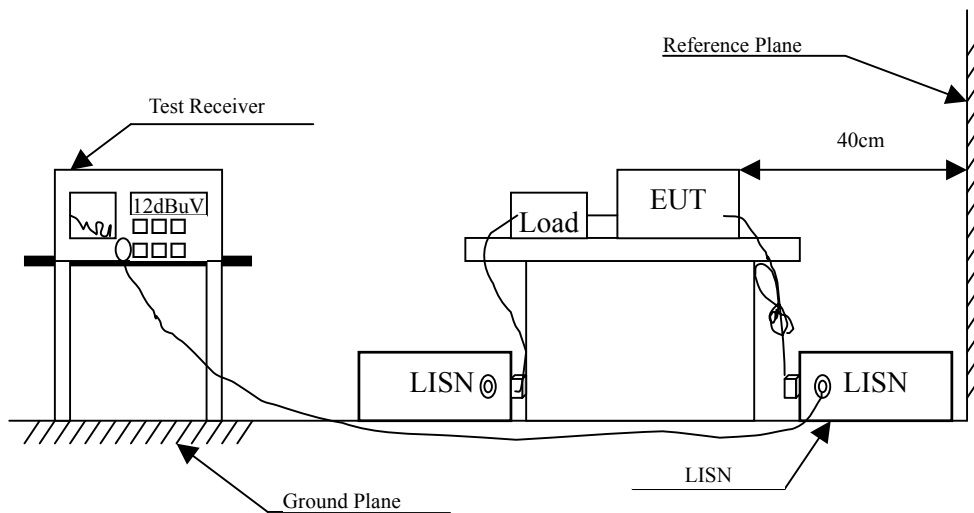

### 2.3. Limits

FCC Part 15 Subpart C Paragraph 15.207 (dBuV) Limit		
Frequency MHz	Limits	
	QP	AV
0.15 - 0.50	66-56	56-46
0.50-5.0	56	46
5.0 - 30	60	50

Remarks : In the above table, the tighter limit applies at the band edges.

## 2.4. Test Procedure

The EUT and simulators are connected to the main power through a line impedance stabilization network (L.I.S.N.). This provides a 50 ohm /50uH coupling impedance for the measuring equipment. The peripheral devices are also connected to the main power through a LISN that provides a 50ohm/50uH coupling impedance with 50ohm termination. (Please refer to the block diagram of the test setup and photographs.)

Both sides of A.C. line are checked for maximum conducted interference. In order to find the maximum emission, the relative positions of equipment and all of the interface cables must be changed according to ANSI C63.4:1992 on conducted measurement.

Conducted emissions were investigated over the frequency range from 0.15MHz to 30MHz using a receiver bandwidth of 9kHz.

## 2.5. Test Result of Conducted Emission

Product : Wireless LAN PC Card  
 Test Item : Conducted Emission  
 Power Line : Line 1  
 Test Mode : Mode 1: Data Rate 11Mbps

Frequency MHz	Cable Loss dB	Probe Factor dB	Reading Level dBuV	Emission Level dBuV	Limits dBuV
<b>Quasi-Peak</b>					
*0.177	0.05	0.12	45.47	45.64	64.60
0.236	0.01	0.14	39.33	39.48	62.24
0.296	0.00	0.16	34.59	34.75	60.37
0.591	0.03	0.23	26.37	26.63	56.00
3.722	0.25	0.40	31.99	32.64	56.00
18.785	0.22	0.56	26.61	27.39	60.00
<b>Average</b>					
0.177	0.05	0.12	36.40	36.57	54.63
0.236	0.01	0.14	28.70	28.85	52.24
0.296	0.00	0.16	25.00	25.16	50.35
0.591	0.03	0.23	24.10	24.36	46.00
3.722	0.25	0.40	22.80	23.45	46.00
18.785	0.22	0.56	21.30	22.08	50.00

Note:

1. All Reading Levels are Quasi-Peak and Average value.
2. “ \* ”, means this data is the worst emission level.
3. Emission Level = Reading Level + LISN Factor + Cable Loss.

Product : Wireless LAN PC Card  
 Test Item : Conducted Emission  
 Power Line : Line 2  
 Test Mode : Mode 1: Data Rate 11Mbps

Frequency MHz	Cable Loss dB	Probe Factor dB	Reading Level dBuV	Emission Level dBuV	Limits dBuV
<b>Quasi-Peak</b>					
*0.177	0.05	0.12	46.87	47.04	64.61
0.236	0.01	0.14	40.01	40.16	62.25
0.294	0.00	0.16	38.35	38.51	60.40
0.354	0.02	0.18	31.39	31.59	58.86
0.471	0.02	0.21	27.91	28.14	56.50
3.651	0.24	0.40	27.55	28.19	56.00
<b>Average</b>					
0.177	0.05	0.12	36.40	36.57	54.63
0.236	0.01	0.14	30.40	30.55	52.24
0.294	0.00	0.16	30.10	30.26	50.41
0.354	0.02	0.18	24.20	24.40	48.87
0.471	0.02	0.21	25.00	25.23	46.50
3.651	0.24	0.40	21.20	21.84	46.00

Note:

1. All Reading Levels are Quasi-Peak and Average value.
2. “ \* ”, means this data is the worst emission level.
3. Emission Level = Reading Level + LISN Factor + Cable Loss.

Product : Wireless LAN PC Card  
 Test Item : Conducted Emission  
 Power Line : Line 1  
 Test Mode : Mode 2: Data Rate 54Mbps

Frequency MHz	Cable Loss dB	Probe Factor dB	Reading Level dBuV	Emission Level dBuV	Limits dBuV
<b>Quasi-Peak</b>					
*0.175	0.05	0.11	46.13	46.29	64.74
0.235	0.01	0.14	38.93	39.08	62.28
0.292	0.02	0.16	33.21	33.39	60.46
0.351	0.02	0.18	30.31	30.51	58.94
3.689	0.24	0.40	27.31	27.95	56.00
18.237	0.22	0.55	21.67	22.44	60.00
<b>Average</b>					
0.175	0.05	0.11	36.00	36.16	54.72
0.235	0.01	0.14	29.30	29.45	52.27
0.292	0.02	0.16	27.30	27.48	50.47
0.351	0.02	0.18	25.40	25.60	48.94
3.689	0.24	0.40	21.30	21.94	46.00
18.237	0.22	0.55	16.10	16.87	50.00

Note:

1. All Reading Levels are Quasi-Peak and Average value.
2. “ \* ”, means this data is the worst emission level.
3. Emission Level = Reading Level + LISN Factor + Cable Loss.

Product : Wireless LAN PC Card  
 Test Item : Conducted Emission  
 Power Line : Line 2  
 Test Mode : Mode 2: Data Rate 54Mbps

Frequency MHz	Cable Loss dB	Probe Factor dB	Reading Level dBuV	Emission Level dBuV	Limits dBuV
<b>Quasi-Peak</b>					
*0.176	0.05	0.11	47.75	47.91	64.67
0.232	-0.03	0.14	39.07	39.19	62.38
0.290	0.02	0.16	34.17	34.35	60.52
0.353	0.02	0.18	34.83	35.03	58.90
0.467	0.02	0.21	30.67	30.90	56.57
3.680	0.24	0.40	27.20	27.84	56.00
<b>Average</b>					
0.176	0.05	0.11	37.30	37.46	54.67
0.232	-0.03	0.14	30.60	30.72	52.38
0.291	0.02	0.16	28.90	29.08	50.50
0.352	0.02	0.18	28.30	28.50	48.92
0.467	0.02	0.21	26.00	26.23	46.57
3.680	0.24	0.40	18.90	19.54	46.00

Note:

1. All Reading Levels are Quasi-Peak and Average value.
2. “ \* ”, means this data is the worst emission level.
3. Emission Level = Reading Level + LISN Factor + Cable Loss.

### 3. Peak Power Output

#### 3.1. Test Equipment

The following test equipment are used during the test:

Item	Equipment	Manufacturer	Model No. / Serial No.	Last Cal.	Remark
1	Power Meter	Agilent	E4416A / GB41291630	May, 2003	
2	Power Sensor	Agilent	E9323A / US40411166	Apr., 2003	
3	No.1 OATS			Sep., 2002	

Note: All equipment upon which need to calibrated are with calibration period of 1 year.

#### 3.2. Test Setup

##### Conduction Power Measurement

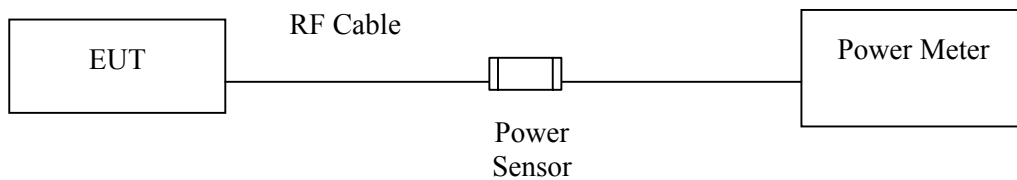

#### 3.3. Limits

The maximum peak power shall be less 1 Watt.



### 3.4. Test Result of Peak Power Output

Product : Wireless LAN PC Card  
Test Item : Peak Power Output  
Test Site : No.1 OATS  
Test Mode : Mode 1: Data Rate 11Mbps

Channel No.	Frequency(MHz)	Measurement	Required Limit	Result
1	2412.00	13.00dBm	1 Watt= 30 dBm	Pass
6	2437.00	13.50dBm	1 Watt= 30 dBm	Pass
11	2462.00	13.76dBm	1 Watt= 30 dBm	Pass

Product : Wireless LAN PC Card  
Test Item : Peak Power Output  
Test Site : No.1 OATS  
Test Mode : Mode 2: Data Rate 54Mbps

Channel No.	Frequency(MHz)	Measurement	Required Limit	Result
1	2412.00	9.82dBm	1 Watt= 30 dBm	Pass
6	2437.00	10.26dBm	1 Watt= 30 dBm	Pass
11	2462.00	10.8dBm	1 Watt= 30 dBm	Pass

## 4. Radiated Emission

### 4.1. Test Equipment

The following test equipment are used during the test:

Item		Equipment	Manufacturer	Model No. / Serial No.	Last Cal.
1	X	Test Receiver	R & S	ESCS 30 / 825442/017	Jan., 2003
2	X	Spectrum Analyzer	Advantest	R3261C / 81720266	N/A
3	X	Pre-Amplifier	HP	8447D / 2944A09276	N/A
4	X	Bilog Antenna	Chase	CBL6112B / 2455	Sep., 2002
5	X	Spectrum Analyzer	R & S	FSP40 / 100005	Aug., 2003
6	X	Pre-Amplifier	HP	8449B / 3008A01123	Feb., 2003
7	X	Horn Antenna	Schwarzbeck	BBHA 9120D / BBHA9120D312	Sep., 2002
8		No.1 OATS			Sep., 2002

Note: 1. All equipments that need to calibrate are with calibration period of 1 year.  
 2. Mark "X" test instruments are used to measure the final test results.

### 4.2. Test Setup

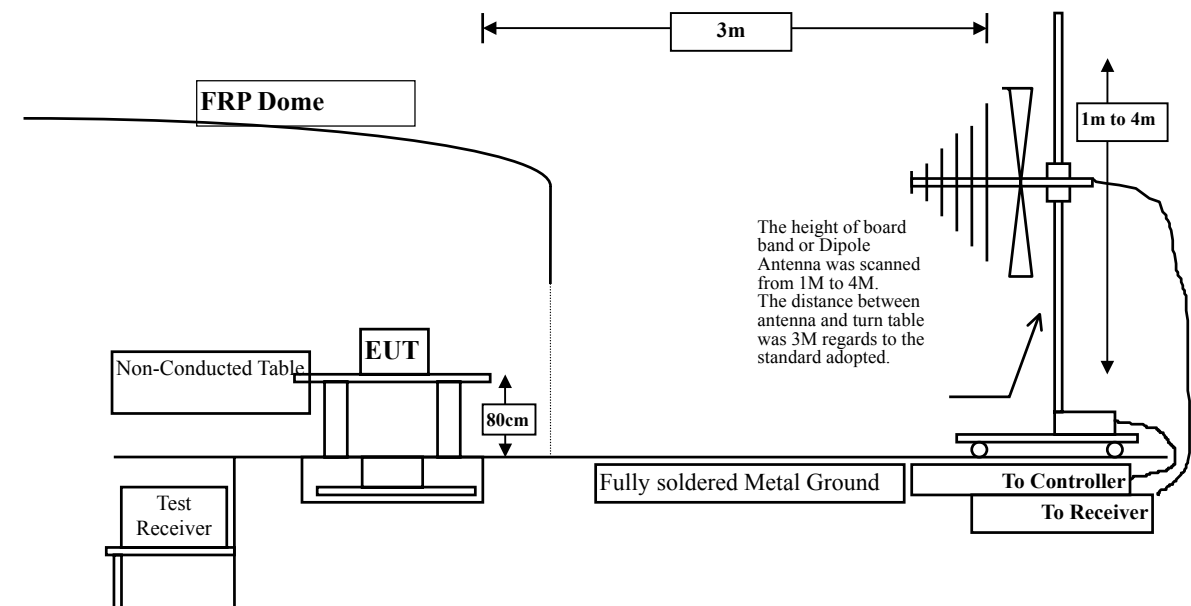

### 4.3. Limits

#### ➤ General Radiated Emission Limits

Emissions radiated outside of the specified frequency bands, except for harmonics, shall be attenuated by at least 20dB below the level of the fundamental or to the general radiated emission limits in paragraph 15.209, whichever is the lesser attenuation.

FCC Part 15 Subpart C Paragraph 15.209 Limits		
Frequency MHz	uV/m @3m	dBuV/m@3m
30-88	100	40
88-216	150	43.5
216-960	200	46
Above 960	500	54

- Remarks :
1. RF Voltage (dBuV) = 20 log RF Voltage (uV)
  2. In the Above Table, the tighter limit applies at the band edges.
  3. Distance refers to the distance in meters between the measuring instrument antenna and the closed point of any part of the device or system.

### 4.4. Test Procedure

The EUT and its simulators are placed on a turn table which is 0.8 meter above ground. The turn table can rotate 360 degrees to determine the position of the maximum emission level. The EUT was positioned such that the distance from antenna to the EUT was 3 meters. The antenna can move up and down between 1 meter and 4 meters to find out the maximum emission level.

Both horizontal and vertical polarization of the antenna are set on measurement. In order to find the maximum emission, all of the interface cables must be manipulated according to ANSI C63.4:1992 on radiated measurement.

The additional latch filter below 1GHz was used to measure the level of harmonics radiated emission during field strength of harmonics measurement.

The bandwidth below 1GHz setting on the field strength meter (R&S Test Receiver ESCS 30 )is 120 kHz, above 1GHz are 1 MHz.

The frequency range from 30MHz to 10th harmonics is checked.

#### 4.5. Test Result of Radiated Emission

Product : Wireless LAN PC Card  
 Test Item : Harmonic Radiated Emission  
 Test Site : No.1 OATS  
 Test Mode : Mode 1: Data Rate 11Mbps (Channel 1)

Frequency	Cable	Probe	PreAMP	Reading	Emission	Margin	Limit
	Loss	Factor		Level	Level		
MHz	dB	dB/m	dB	dBuV	dBuV/m	dB	dBuV/m

##### Horizontal

###### Peak Detector:

4824.062	4.24	31.31	34.38	49.35	50.52	23.48	74.00
7235.842	5.63	36.54	34.94	44.82	52.05	21.95	74.00
9647.793	7.01	37.98	34.43	41.96	<52.52	21.48	74.00
12059.78	8.40	38.59	33.24	39.45	<53.20	20.80	74.00

##### Vertical

###### Peak Detector:

4824.006	4.24	31.28	34.38	49.51	50.66	23.34	74.00
7236.189	5.63	36.54	34.94	44.01	51.24	22.76	74.00
9647.881	7.01	37.98	34.43	41.35	<51.91	22.09	74.00
12059.97	8.40	38.59	33.24	39.24	<52.99	21.01	74.00

##### Note:

1. All Readings below 1GHz are Quasi-Peak, above are performed with peak and/or average measurements as necessary.
2. Receiver setting (Peak Detector) : RBW:1MHz; VBW:1MHz; Span:100MHz ◦
3. Receiver setting (AVG Detector) : RBW:1MHz; VBW:30Hz; Span:20MHz ◦
4. Emission Level = Reading Level + Probe Factor + Cable Loss – PreAMP.
5. The average measurement was not performed when the peak measured data under the limit of average detection. If the readings given are average, peak measurement should also be supplied.

Product : Wireless LAN PC Card  
 Test Item : Harmonic Radiated Emission  
 Test Site : No.1 OATS  
 Test Mode : Mode 1: Data Rate 11Mbps (Channel 6)

Frequency	Cable	Probe	PreAMP	Reading	Emission	Margin	Limit
	Loss	Factor		Level	Level		
MHz	dB	dB/m	dB	dBuV	dBuV/m	dB	dBuV/m

### Horizontal

#### Peak Detector:

4874.181	4.27	31.37	34.37	48.83	50.11	23.89	74.00
7311.098	5.67	36.56	34.97	43.33	50.59	23.41	74.00
9747.968	7.07	38.13	34.31	42.65	<53.54	20.46	74.00
12185.08	8.47	38.51	33.31	39.41	<53.07	20.93	74.00

### Vertical

#### Peak Detector:

4873.918	4.27	31.37	34.37	49.38	50.66	23.34	74.00
7311.085	5.68	36.57	34.98	43.86	51.12	22.88	74.00
9748.093	7.07	38.13	34.31	42.44	<53.33	20.67	74.00
12185.09	8.47	38.51	33.31	39.52	<53.18	20.82	74.00

#### Note:

1. All Readings below 1GHz are Quasi-Peak, above are performed with peak and/or average measurements as necessary.
2. Receiver setting (Peak Detector) : RBW:1MHz; VBW:1MHz; Span:100MHz ◦
3. Receiver setting (AVG Detector) : RBW:1MHz; VBW:30Hz; Span:20MHz ◦
4. Emission Level = Reading Level + Probe Factor + Cable Loss – PreAMP.
5. The average measurement was not performed when the peak measured data under the limit of average detection. If the readings given are average, peak measurement should also be supplied.

Product : Wireless LAN PC Card  
 Test Item : Harmonic Radiated Emission  
 Test Site : No.1 OATS  
 Test Mode : Mode 1: Data Rate 11Mbps (Channel 11)

Frequency	Cable	Probe	PreAMP	Reading	Emission	Margin	Limit
MHz	Loss	Factor	dB	Level	Level	dB	dBuV/m
	dB	dB/m		dBuV	dBuV/m		

### Horizontal

#### Peak Detector:

4923.943	4.30	31.43	34.36	49.21	50.58	23.42	74.00
7385.914	5.72	36.59	35.02	42.44	49.73	24.27	74.00
9848.000	7.13	38.18	34.18	41.67	<52.79	21.21	74.00
12310.11	8.53	38.43	33.39	39.03	<52.61	21.39	74.00

### Vertical

#### Peak Detector:

4923.981	4.30	31.43	34.36	49.52	50.89	23.11	74.00
7386.067	5.72	36.59	35.02	43.39	50.68	23.32	74.00
9747.941	7.07	38.13	34.31	41.22	<52.11	21.89	74.00
12310.12	8.53	38.43	33.39	39.14	<52.72	21.28	74.00

#### Note:

1. All Readings below 1GHz are Quasi-Peak, above are performed with peak and/or average measurements as necessary.
2. Receiver setting (Peak Detector) : RBW:1MHz; VBW:1MHz; Span:100MHz ◦
3. Receiver setting (AVG Detector) : RBW:1MHz; VBW:30Hz; Span:20MHz ◦
4. Emission Level = Reading Level + Probe Factor + Cable Loss – PreAMP.
5. The average measurement was not performed when the peak measured data under the limit of average detection. If the readings given are average, peak measurement should also be supplied.

Product : Wireless LAN PC Card  
 Test Item : Harmonic Radiated Emission  
 Test Site : No.1 OATS  
 Test Mode : Mode 2: Data Rate 54Mbps (Channel 1)

Frequency	Cable	Probe	PreAMP	Reading	Emission	Margin	Limit
MHz	Loss	Factor	dB	Level	Level	dB	dBuV/m
	dB	dB/m		dBuV	dBuV/m		

### Horizontal

#### Peak Detector:

4823.843	4.24	31.28	34.38	47.27	48.42	25.58	74.00
7236.111	5.63	36.54	34.94	43.46	50.69	23.31	74.00
9648.196	7.01	37.98	34.43	42.02	<52.58	21.42	74.00
12060.31	8.40	38.59	33.24	39.72	<53.47	20.53	74.00

### Vertical

#### Peak Detector:

4824.131	4.24	31.28	34.38	47.74	48.89	25.11	74.00
7236.131	5.63	36.54	34.94	43.85	51.08	22.92	74.00
9648.068	7.01	37.98	34.43	41.26	<51.82	22.18	74.00
12059.93	8.40	38.59	33.24	39.46	<53.21	20.79	74.00

#### Note:

1. All Readings below 1GHz are Quasi-Peak, above are performed with peak and/or average measurements as necessary.
2. Receiver setting (Peak Detector) : RBW:1MHz; VBW:1MHz; Span:100MHz ◦
3. Receiver setting (AVG Detector) : RBW:1MHz; VBW:30Hz; Span:20MHz ◦
4. Emission Level = Reading Level + Probe Factor + Cable Loss – PreAMP.
5. The average measurement was not performed when the peak measured data under the limit of average detection. If the readings given are average, peak measurement should also be supplied.



Product : Wireless LAN PC Card  
 Test Item : Harmonic Radiated Emission  
 Test Site : No.1 OATS  
 Test Mode : Mode 2: Data Rate 54Mbps (Channel 6)

Frequency	Cable	Probe	PreAMP	Reading	Emission	Margin	Limit
MHz	Loss	Factor	dB	Level	Level	dB	dBuV/m
	dB	dB/m		dBuV	dBuV/m		

### Horizontal

#### Peak Detector:

4873.931	4.27	31.37	34.37	48.36	49.64	24.36	74.00
7311.150	5.67	36.56	34.97	44.59	51.85	22.15	74.00
9747.952	7.07	38.13	34.31	41.96	<52.85	21.15	74.00
12184.86	8.47	38.51	33.31	39.64	<53.30	20.70	74.00

### Vertical

#### Peak Detector:

4873.906	4.27	31.37	34.37	48.46	49.74	24.26	74.00
7310.902	5.67	36.56	34.97	44.11	51.37	22.63	74.00
9748.125	7.07	38.13	34.31	42.02	<52.91	21.09	74.00
12184.93	8.47	38.51	33.31	39.88	<53.54	20.46	74.00

#### Note:

1. All Readings below 1GHz are Quasi-Peak, above are performed with peak and/or average measurements as necessary.
2. Receiver setting (Peak Detector) : RBW:1MHz; VBW:1MHz; Span:100MHz ◦
3. Receiver setting (AVG Detector) : RBW:1MHz; VBW:30Hz; Span:20MHz ◦
4. Emission Level = Reading Level + Probe Factor + Cable Loss – PreAMP.
5. The average measurement was not performed when the peak measured data under the limit of average detection. If the readings given are average, peak measurement should also be supplied.

Product : Wireless LAN PC Card  
 Test Item : Harmonic Radiated Emission  
 Test Site : No.1 OATS  
 Test Mode : Mode 2: Data Rate 54Mbps (Channel 11)

Frequency	Cable	Probe	PreAMP	Reading	Emission	Margin	Limit
	Loss	Factor		Level	Level		
MHz	dB	dB/m	dB	dBuV	dBuV/m	dB	dBuV/m

### Horizontal

#### Peak Detector:

4924.093	4.30	31.43	34.36	47.89	49.26	24.74	74.00
7386.294	5.72	36.59	35.02	43.36	50.65	23.35	74.00
9847.830	7.13	38.18	34.18	41.39	<52.51	21.49	74.00
12309.90	8.53	38.43	33.39	39.34	<52.92	21.08	74.00

### Vertical

#### Peak Detector:

4923.798	4.30	31.43	34.36	48.97	50.34	23.66	74.00
7386.027	5.72	36.59	35.02	43.14	50.43	23.57	74.00
9847.864	7.13	38.18	34.18	41.80	<52.92	21.08	74.00
12310.16	8.53	38.43	33.39	39.22	<52.80	21.20	74.00

#### Note:

1. All Readings below 1GHz are Quasi-Peak, above are performed with peak and/or average measurements as necessary.
2. Receiver setting (Peak Detector) : RBW:1MHz; VBW:1MHz; Span:100MHz ◦
3. Receiver setting (AVG Detector) : RBW:1MHz; VBW:30Hz; Span:20MHz ◦
4. Emission Level = Reading Level + Probe Factor + Cable Loss – PreAMP.
5. The average measurement was not performed when the peak measured data under the limit of average detection. If the readings given are average, peak measurement should also be supplied.

Product : Wireless LAN PC Card  
 Test Item : General Radiated Emission  
 Test Site : No.1 OATS  
 Test Mode : Mode 1: Data Rate 11Mbps (Channel 1)

Frequency	Cable	Probe	PreAMP	Reading	Emission	Margin	Limit
MHz	Loss	Factor	dB	Level	Level	dB	dBuV/m
	dB	dB/m		dBuV	dBuV/m		

### Horizontal

239.520	1.88	8.37	22.60	41.60	29.24	16.76	46.00
331.670	2.26	14.59	22.60	41.40	35.64	10.36	46.00
396.660	2.52	16.14	22.60	38.80	34.86	11.14	46.00
465.530	2.80	16.12	22.60	41.40	37.72	8.28	46.00
530.520	3.07	21.41	22.60	35.00	36.88	9.12	46.00
*558.650	3.19	21.94	22.60	36.60	39.13	6.87	46.00

### Vertical

146.400	1.50	15.45	22.60	42.20	36.54	6.96	43.50
*189.080	1.67	18.48	22.60	42.00	39.55	3.95	43.50
211.390	1.76	12.76	22.60	47.40	39.32	4.18	43.50
330.700	2.25	15.90	22.60	38.20	33.75	12.25	46.00
561.560	3.20	20.31	22.60	32.00	32.91	13.09	46.00
873.900	4.48	23.93	22.60	27.80	33.62	12.38	46.00

### Note:

1. All Readings below 1GHz are Quasi-Peak, above are performed with peak and/or average measurements as necessary.
2. “ \* ”, means this data is the worst emission level.
3. Emission Level = Reading Level + Probe Factor + Cable Loss-PreAMP.

Product : Wireless LAN PC Card  
 Test Item : General Radiated Emission  
 Test Site : No.1 OATS  
 Test Mode : Mode 1: Data Rate 11Mbps (Channel 6)

Frequency	Cable	Probe	PreAMP	Reading	Emission	Margin	Limit
MHz	Loss	Factor	dB	Level	Level	dB	dBuV/m
	dB	dB/m		dBuV	dBuV/m		

### Horizontal

188.110	1.66	9.32	22.60	39.60	27.98	15.52	43.50
265.710	1.98	11.35	22.60	44.40	35.14	10.86	46.00
352.040	2.34	14.23	22.60	41.40	35.37	10.63	46.00
449.040	2.74	15.28	22.60	41.40	36.81	9.19	46.00
*579.990	3.28	21.75	22.60	36.00	38.43	7.57	46.00
891.360	4.55	24.89	22.60	26.80	33.64	12.36	46.00

### Vertical

156.100	1.54	18.38	22.60	39.40	36.71	6.79	43.50
*187.140	1.66	18.32	22.60	40.80	38.18	5.32	43.50
208.480	1.75	12.56	22.60	44.40	36.11	7.39	43.50
330.700	2.25	15.90	22.60	38.00	33.55	12.45	46.00
529.550	3.07	18.67	22.60	33.20	32.34	13.66	46.00
841.890	4.35	24.68	22.60	27.00	33.43	12.57	46.00

### Note:

1. All Readings below 1GHz are Quasi-Peak, above are performed with peak and/or average measurements as necessary.
2. “ \* ”, means this data is the worst emission level.
3. Emission Level = Reading Level + Probe Factor + Cable Loss-PreAMP.

Product : Wireless LAN PC Card  
 Test Item : General Radiated Emission  
 Test Site : No.1 OATS  
 Test Mode : Mode 1: Data Rate 11Mbps (Channel 11)

Frequency	Cable	Probe	PreAMP	Reading	Emission	Margin	Limit
MHz	Loss	Factor	dB	Level	Level	dB	dBuV/m
	dB	dB/m		dBuV	dBuV/m		

### Horizontal

264.740	1.98	11.23	22.60	46.20	36.81	9.19	46.00
353.010	2.34	14.23	22.60	43.80	37.77	8.23	46.00
450.980	2.74	15.38	22.60	41.20	36.72	9.28	46.00
529.550	3.07	21.20	22.60	33.00	34.67	11.33	46.00
*574.170	3.25	21.80	22.60	35.40	37.85	8.15	46.00
927.250	4.70	25.17	22.60	28.20	35.47	10.53	46.00

### Vertical

156.100	1.54	18.38	22.60	40.00	37.31	6.19	43.50
*178.410	1.62	17.60	22.60	41.00	37.62	5.88	43.50
221.090	1.80	13.43	22.60	44.40	37.03	8.97	46.00
330.700	2.25	15.90	22.60	36.60	32.15	13.85	46.00
452.920	2.75	14.04	22.60	37.80	31.99	14.01	46.00
841.890	4.35	24.68	22.60	28.00	34.43	11.57	46.00

### Note:

1. All Readings below 1GHz are Quasi-Peak, above are performed with peak and/or average measurements as necessary.
2. “ \* ”, means this data is the worst emission level.
3. Emission Level = Reading Level + Probe Factor + Cable Loss-PreAMP.

Product : Wireless LAN PC Card  
 Test Item : General Radiated Emission  
 Test Site : No.1 OATS  
 Test Mode : Mode 2: Data Rate 54Mbps (Channel 1)

Frequency	Cable	Probe	PreAMP	Reading	Emission	Margin	Limit
MHz	Loss	Factor	dB	Level	Level	dB	dBuV/m
	dB	dB/m		dBuV	dBuV/m		

**Horizontal**

330.700	2.25	14.61	22.60	37.60	31.87	14.13	46.00
395.690	2.52	16.18	22.60	38.40	34.50	11.50	46.00
454.860	2.76	15.57	22.60	40.20	35.93	10.07	46.00
*567.380	3.22	21.86	22.60	33.60	36.09	9.91	46.00
793.390	4.15	22.30	22.60	29.60	33.46	12.54	46.00
922.400	4.68	25.16	22.60	27.80	35.04	10.96	46.00

**Vertical**

*146.400	1.50	15.45	22.60	44.40	38.74	4.76	43.50
158.040	1.54	18.97	22.60	40.40	38.32	5.18	43.50
177.440	1.62	17.52	22.60	41.60	38.14	5.36	43.50
210.420	1.76	12.69	22.60	46.00	37.85	5.65	43.50
528.580	3.06	18.62	22.60	33.00	32.08	13.92	46.00
842.860	4.36	24.68	22.60	28.00	34.44	11.56	46.00

**Note:**

1. All Readings below 1GHz are Quasi-Peak, above are performed with peak and/or average measurements as necessary.
2. “ \* ”, means this data is the worst emission level.
3. Emission Level = Reading Level + Probe Factor + Cable Loss-PreAMP.

Product : Wireless LAN PC Card  
 Test Item : General Radiated Emission  
 Test Site : No.1 OATS  
 Test Mode : Mode 2: Data Rate 54Mbps (Channel 6)

Frequency	Cable	Probe	PreAMP	Reading	Emission	Margin	Limit
MHz	Loss	Factor	dB	Level	Level	dB	dBuV/m
	dB	dB/m		dBuV	dBuV/m		

### Horizontal

198.780	1.71	9.28	22.60	43.20	31.59	11.91	43.50
356.890	2.36	14.23	22.60	42.00	35.99	10.01	46.00
397.630	2.53	16.09	22.60	40.40	36.42	9.58	46.00
452.920	2.75	15.48	22.60	41.20	36.83	9.17	46.00
*465.530	2.80	16.12	22.60	43.20	39.52	6.48	46.00
572.230	3.24	21.82	22.60	32.40	34.86	11.14	46.00

### Vertical

*188.110	1.66	18.40	22.60	39.60	37.06	6.44	43.50
221.090	1.80	13.43	22.60	41.40	34.03	11.97	46.00
330.700	2.25	15.90	22.60	37.60	33.15	12.85	46.00
356.890	2.36	15.23	22.60	37.60	32.59	13.41	46.00
451.950	2.75	14.02	22.60	37.00	31.16	14.84	46.00
528.580	3.06	18.62	22.60	33.40	32.48	13.52	46.00

### Note:

1. All Readings below 1GHz are Quasi-Peak, above are performed with peak and/or average measurements as necessary.
2. “ \* ”, means this data is the worst emission level.
3. Emission Level = Reading Level + Probe Factor + Cable Loss-PreAMP.

Product : Wireless LAN PC Card  
 Test Item : General Radiated Emission  
 Test Site : No.1 OATS  
 Test Mode : Mode 2: Data Rate 54Mbps (Channel 11)

Frequency	Cable	Probe	PreAMP	Reading	Emission	Margin	Limit
MHz	Loss	Factor	dB	Level	Level	dB	dBuV/m
	dB	dB/m		dBuV	dBuV/m		

**Horizontal**

256.010	1.94	10.09	22.60	39.00	28.44	17.56	46.00
330.700	2.25	14.61	22.60	37.20	31.47	14.53	46.00
394.720	2.52	16.23	22.60	38.20	34.34	11.66	46.00
*577.080	3.26	21.78	22.60	35.00	37.44	8.56	46.00
663.410	3.62	18.12	22.60	33.80	32.93	13.07	46.00
841.890	4.35	24.75	22.60	27.00	33.50	12.50	46.00

**Vertical**

168.710	1.59	19.74	22.60	33.20	31.93	11.57	43.50
*187.140	1.66	18.32	22.60	35.20	32.58	10.92	43.50
330.700	2.25	15.90	22.60	32.00	27.55	18.45	46.00
530.520	3.07	18.73	22.60	31.60	30.80	15.20	46.00
842.860	4.36	24.68	22.60	27.40	33.84	12.16	46.00
922.400	4.68	21.95	22.60	27.00	31.03	14.97	46.00

**Note:**

1. All Readings below 1GHz are Quasi-Peak, above are performed with peak and/or average measurements as necessary.
2. “ \* ”, means this data is the worst emission level.
3. Emission Level = Reading Level + Probe Factor + Cable Loss-PreAMP.



## 5. Band Edge

### 5.1. Test Equipment

The following test equipment are used during the test:

RF Conducted Measurement:

Item	Equipment	Manufacturer	Model No. / Serial No.	Last Cal.	Remark
1	Spectrum Analyzer	R & S	FSP / 100561	Mar., 2003	
2	No.1 OATS			N/A	

RF Radiated Measurement:

Item		Equipment	Manufacturer	Model No. / Serial No.	Last Cal.
1	X	Spectrum Analyzer	R & S	FSP40 / 100005	Aug., 2003
2	X	Pre-Amplifier	HP	8449B / 3008A01123	Feb., 2003
3		Loop Antenna	R & S	HFH2-Z2 / 833799/004	Sep., 2002
4		BiconiLog Antenna	Schwarzbeck	VULB 9166 / 1061	Sep., 2002
5		Bilog Antenna	Chase	CBL6112B / 2455	Sep., 2002
6	X	Horn Antenna	Schwarzbeck	BBHA 9120D / BBHA9120D312	Sep., 2002
7		No.1 OATS			Sep., 2002

- Note:
1. All equipments that need to calibrate are with calibration period of 1 year.
  2. Mark "X" test instruments are used to measure the final test results.

## 5.2. Test Setup

### RF Conducted Measurement:

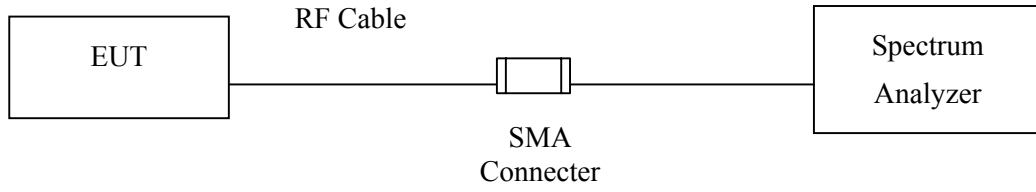

### RF Radiated Measurement:

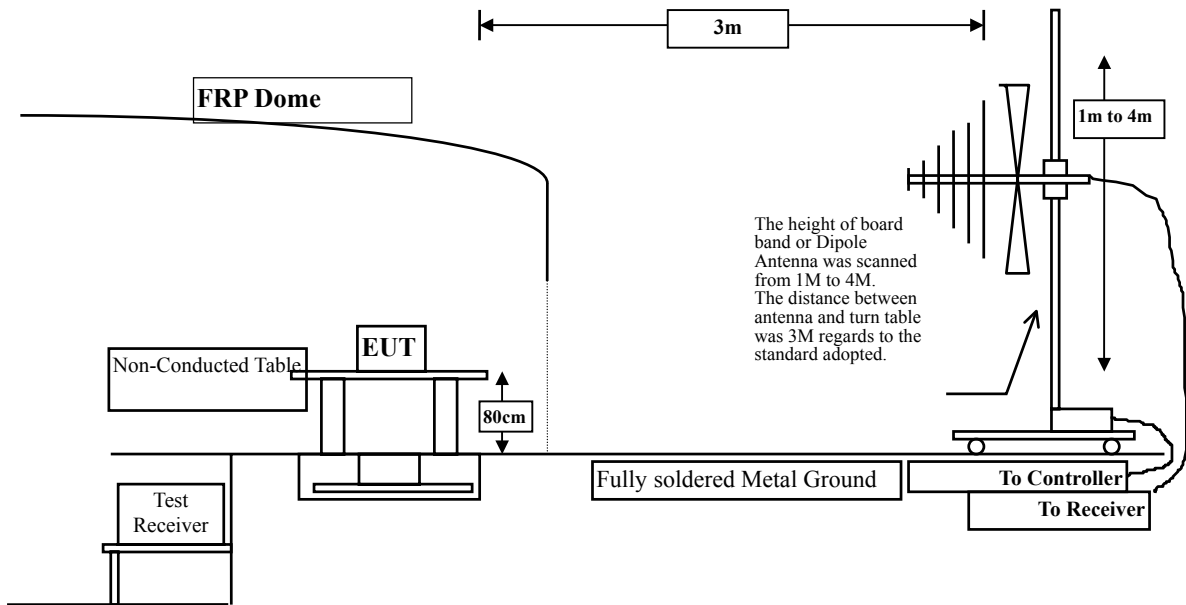

### 5.3. Limits

In any 100 kHz bandwidth outside the frequency band in which the spread spectrum intentional radiator is operating, the radio frequency power that is produced by the intentional radiator shall be at least 20 dB below that in the 100 kHz bandwidth within the band that contains the highest level of the desired power, based on either an RF conducted or a radiated measurement. Attenuation below the general limits specified in Section 15.209(a) is not required. In addition, radiated emissions which fall in the restricted bands, as defined in Section 15.205(a), must also comply with the radiated emission limits specified in Section 15.209(a) (see Section 15.205(c)).

### 5.4. Test Procedure

The EUT and its simulators are placed on a turn table which is 0.8 meter above ground. The turn table can rotate 360 degrees to determine the position of the maximum emission level. The EUT was positioned such that the distance from antenna to the EUT was 3 meters.

The antenna can move up and down between 1 meter and 4 meters to find out the maximum emission level.

Both horizontal and vertical polarization of the antenna are set on measurement. In order to find the maximum emission, all of the interface cables must be manipulated according to ANSI C63.4:1992 on radiated measurement.

The bandwidth below 1GHz setting on the field strength meter (R&S Test Receiver ESCS 30 )is 120 kHz, above 1GHz are 1 MHz.

### 5.5. Test Result of Band Edge

Product : Wireless LAN PC Card  
 Test Item : Band Edge  
 Test Site : No.1 OATS  
 Test Mode : Mode 1: Data Rate 11Mbps (Channel 1)

#### RF Radiated Measurement:

Channel No.	Frequency (MHz)	Required Limit (dBc)	Result
1 (Horizontal)	<2400	>20	Pass
1 (Vertical)	<2400	>20	Pass

Figure Channel 1: (Horizontal)

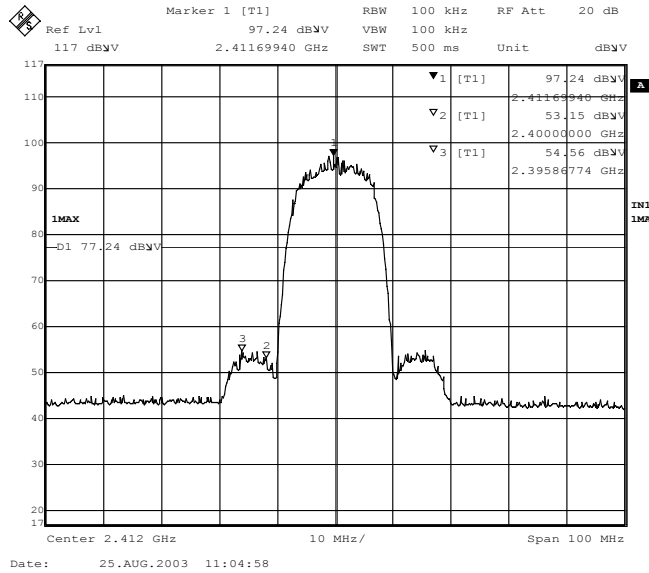
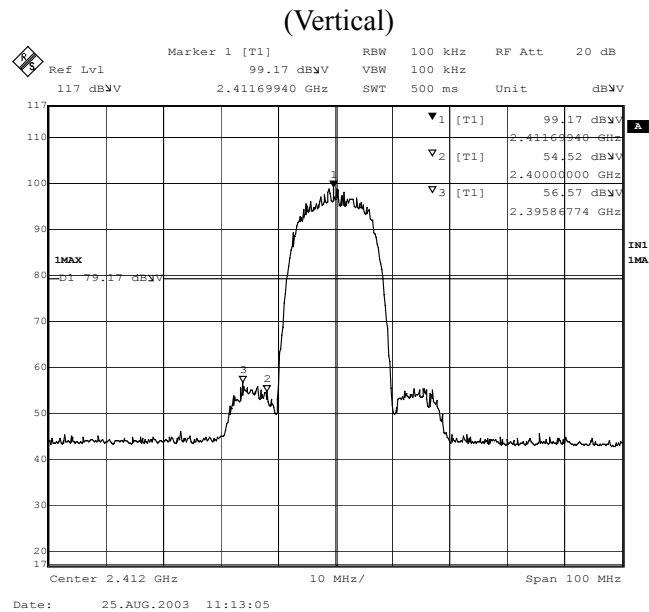

Figure Channel 1: (Vertical)



Product : Wireless LAN PC Card  
 Test Item : Band Edge  
 Test Site : No.1 OATS  
 Test Mode : Mode 2: Data Rate 54Mbps (Channel 1)

**RF Radiated Measurement:**

Channel No.	Frequency (MHz)	Required Limit (dBc)	Result
1 (Horizontal)	<2400	>20	Pass
1 (Vertical)	<2400	>20	Pass

**Figure Channel 1: (Horizontal)**

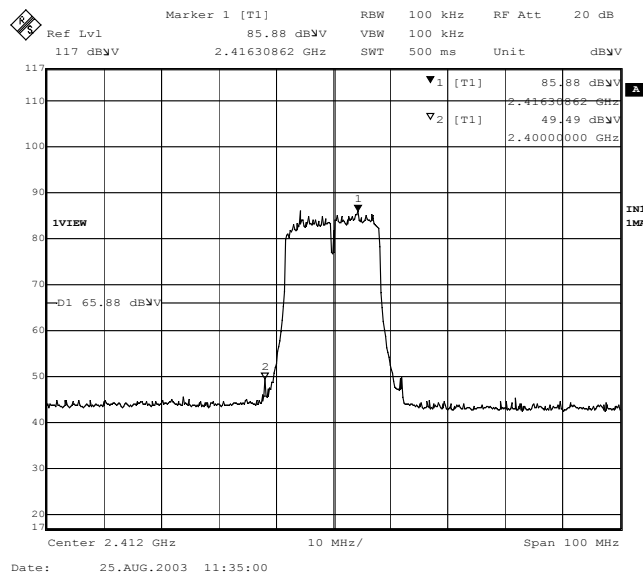

**Figure Channel 1: (Vertical)**

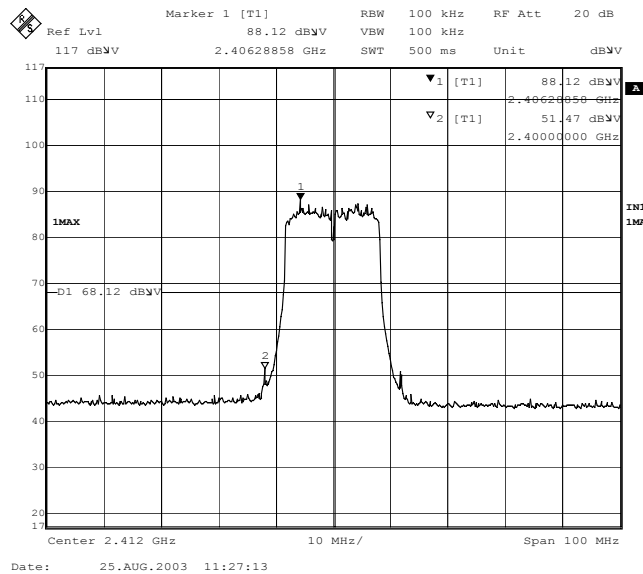

Product : Wireless LAN PC Card  
 Test Item : Band Edge  
 Test Site : No.1 OATS  
 Test Mode : Mode 1: Data Rate 11Mbps (Channel 11)

**RF Radiated Measurement: (Peak Detector)**

Channel No.	Frequency (MHz)	Reading Level (dBUV)	Probe Factor (dB/m)	Cable Loss (dB)	PreAMP (dB)	Emission Level (dBUV/m)	Limit (dBUV/m)	Result
11(Horizontal)	2490.517	51.26	27.58	2.91	34.56	47.19	74	Pass
11 (Vertical)	2489.635	53.51	27.58	2.91	34.56	49.44	74	Pass

**Figure Channel 11:**

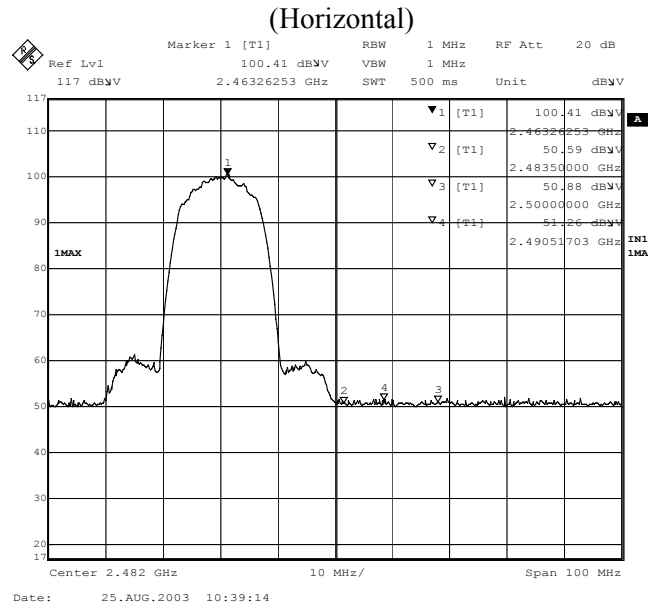

**Figure Channel 11:**

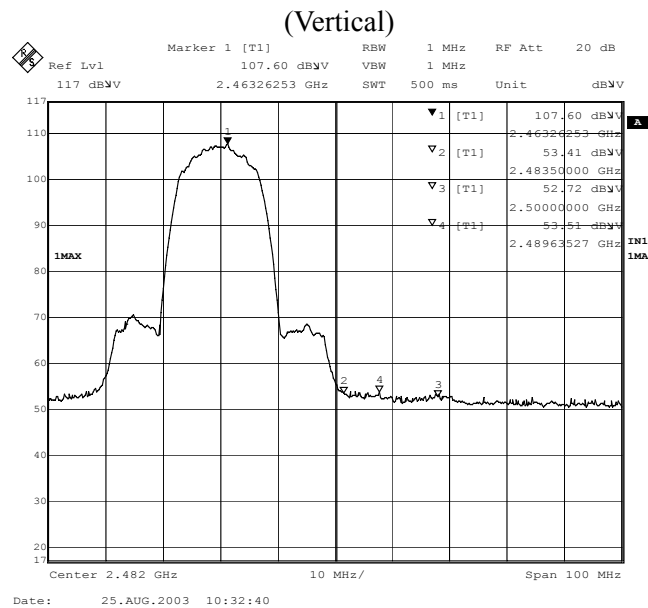

Note: The average measurement was not performed when the peak measured data under the limit of average detection. If the readings given are average, peak measurement should also be supplied.

Product : Wireless LAN PC Card  
 Test Item : Band Edge  
 Test Site : No.1 OATS  
 Test Mode : Mode 2: Data Rate 54Mbps (Channel 11)

**RF Radiated Measurement: (Peak Detector)**

Channel No.	Frequency (MHz)	Reading Level (dBUV)	Probe Factor (dB/m)	Cable Loss (dB)	PreAMP (dB)	Emission Level (dBUV/m)	Limit (dBUV/m)	Result
11(Horizontal)	2492.320	51.84	27.58	2.91	34.56	47.77	74	Pass
11 (Vertical)	2483.703	53.45	27.58	2.90	34.58	49.35	74	Pass

**Figure Channel 11:**

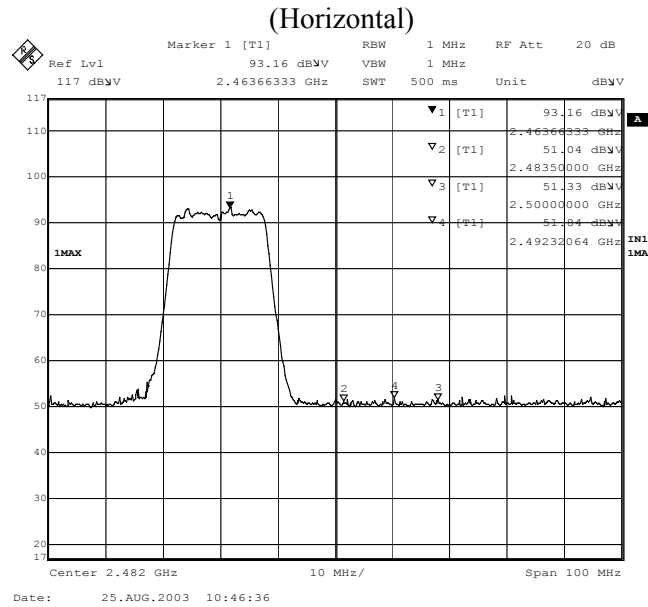

**Figure Channel 11:**

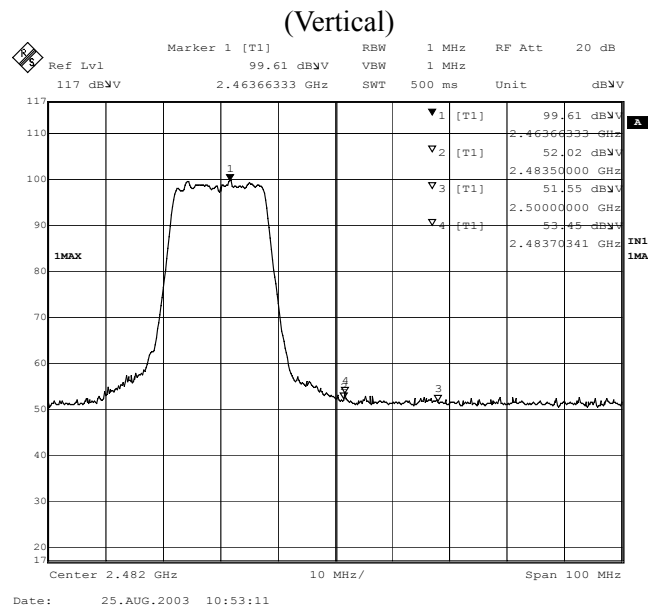

Note: The average measurement was not performed when the peak measured data under the limit of average detection. If the readings given are average, peak measurement should also be supplied.

## 6. Occupied Bandwidth

### 6.1. Test Equipment

The following test equipment are used during the test:

Item	Equipment	Manufacturer	Model No. / Serial No.	Last Cal.	Remark
1	Spectrum Analyzer	R & S	FSP / 100561	Mar., 2003	
2	No.1 OATS			N/A	

Note: All equipment upon which need to calibrated are with calibration period of 1 year.

### 6.2. Test Setup

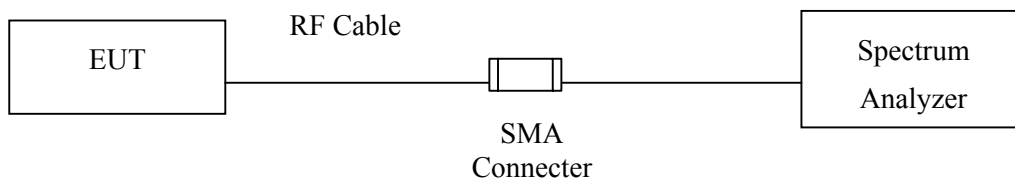

### 6.3. Limits

The minimum 6dB bandwidth shall be at least 500kHz.



### 6.4. Test Result of Occupied Bandwidth

Product : Wireless LAN PC Card  
 Test Item : Occupied Bandwidth  
 Test Site : No.1 OATS  
 Test Mode : Mode 1: Data Rate 11Mbps

Channel No.	Frequency (MHz)	Measurement Level (kHz)	Required Limit (kHz)	Result
1	2412.00	11800	>500	Pass
6	2437.00	11800	>500	Pass
11	2462.00	11800	>500	Pass

**Channel 1:**

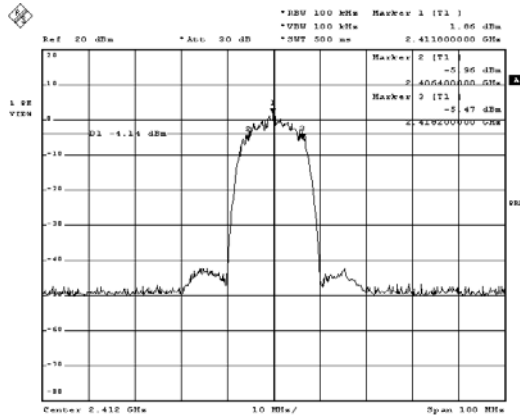

Date: 20.AUG.2009 10:20:54

**Channel 6**

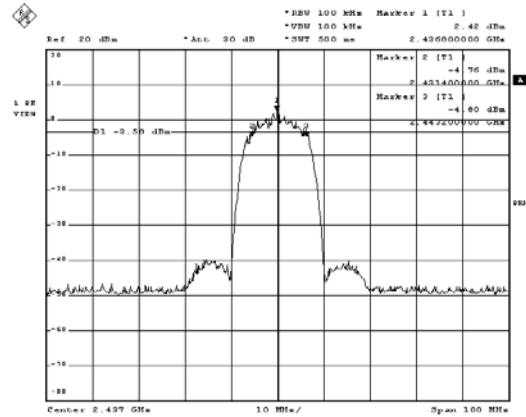

Date: 20.AUG.2009 10:36:00

**Channel 11:**

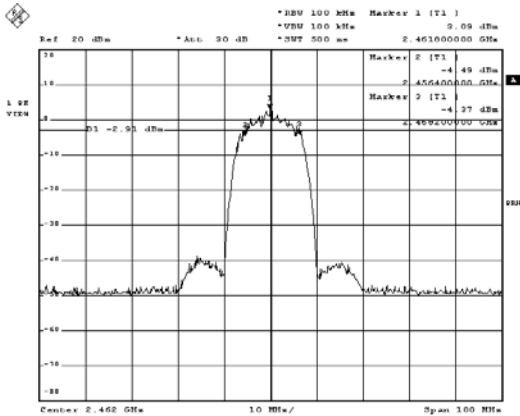

Date: 20.AUG.2009 10:37:37

Product : Wireless LAN PC Card  
 Test Item : Occupied Bandwidth  
 Test Site : No.1 OATS  
 Test Mode : Mode 2: Data Rate 54Mbps

Channel No.	Frequency (MHz)	Measurement Level (kHz)	Required Limit (kHz)	Result
1	2412.00	16800	>500	Pass
6	2437.00	16800	>500	Pass
11	2462.00	16800	>500	Pass

**Channel 1:**

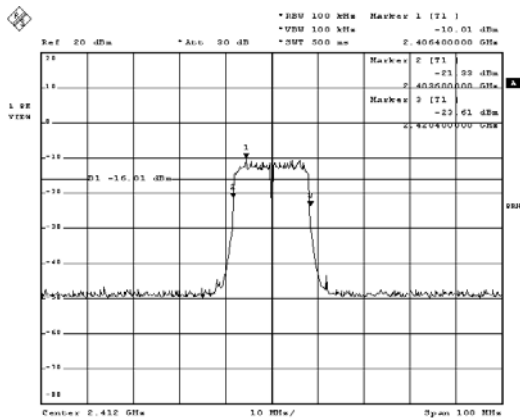

Date: 20. AUG. 2009 10:31:04

**Channel 6**

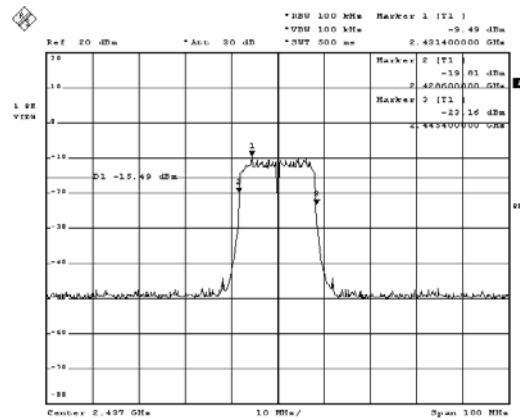

Date: 20. AUG. 2009 10:32:28

**Channel 11:**

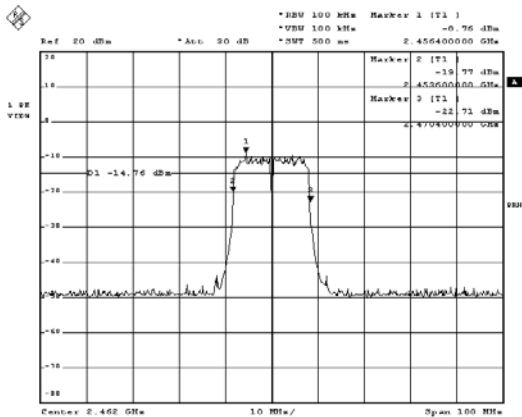

Date: 20. AUG. 2009 10:39:06

## 7. Power Density

### 7.1. Test Equipment

The following test equipment are used during the test:

Item	Equipment	Manufacturer	Model No. / Serial No.	Last Cal.	Remark
1	Spectrum Analyzer	R & S	FSP / 100561	Mar., 2003	
2	No.1 OATS			N/A	

Note: All equipment upon which need to calibrated are with calibration period of 1 year.

### 7.2. Test Setup

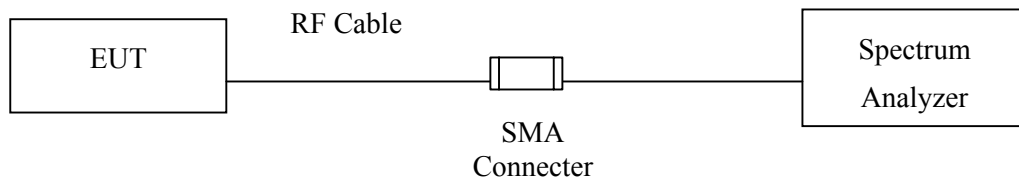

### 7.3. Limits

The transmitted power density averaged over any 1 second interval shall not be greater +8dBm in any 3kHz bandwidth.

### 7.4. Test Result of Power Density

Product : Wireless LAN PC Card  
 Test Item : Power Density  
 Test Site : No.1 OATS  
 Test Mode : Mode 1: Data Rate 11Mbps

Channel No.	Frequency (MHz)	Measurement Level (dBm)	Required Limit (dBm)	Result
1	2411.994	-12.65	< 8dBm	Pass
6	2436.994	-11.9	< 8dBm	Pass
11	2461.994	-11.31	< 8dBm	Pass

**Channel 1:**

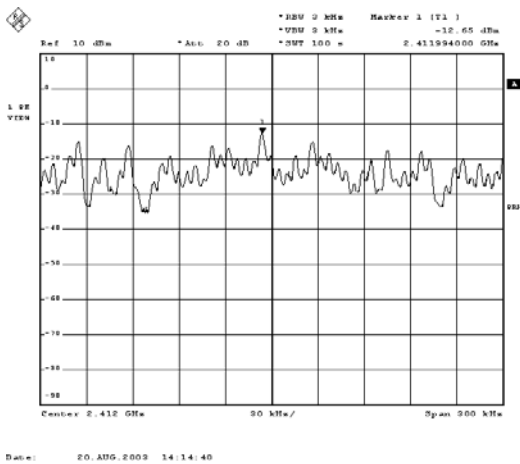

**Channel 6**

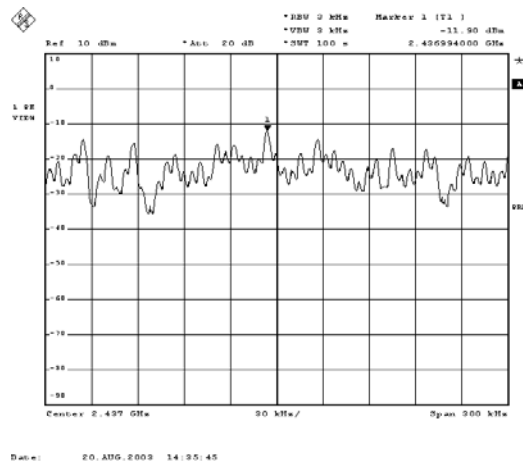

**Channel 11:**

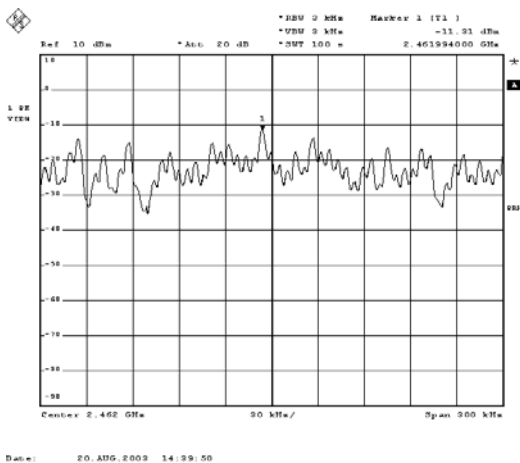

Product : Wireless LAN PC Card  
 Test Item : Power Density  
 Test Site : No.1 OATS  
 Test Mode : Mode 2: Data Rate 54Mbps

Channel No.	Frequency (MHz)	Measurement Level (dBm)	Required Limit (dBm)	Result
1	2412.130	-32.65	< 8dBm	Pass
6	2436.974	-30.69	< 8dBm	Pass
11	2462.131	-31.45	< 8dBm	Pass

**Channel 1:**

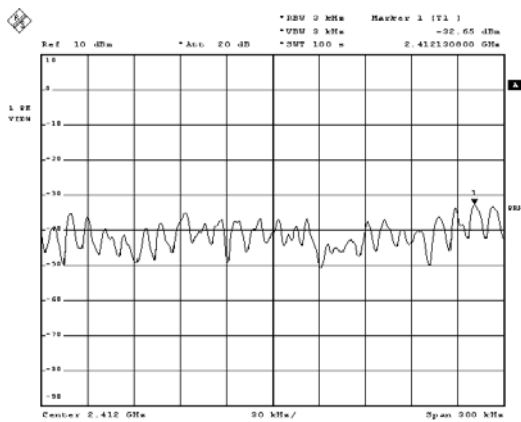

Date: 20.AUG.2009 14:19:52

**Channel 6**

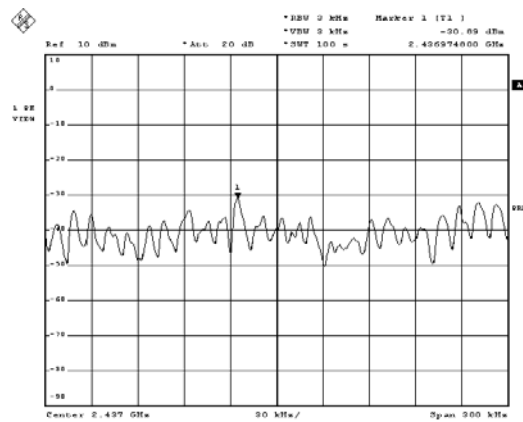

Date: 20.AUG.2009 14:25:50

**Channel 11:**

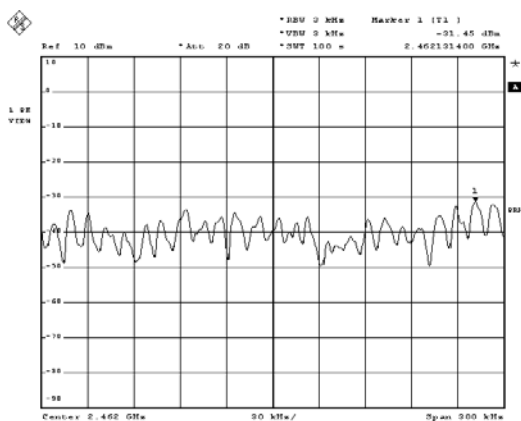

Date: 20.AUG.2009 14:49:58

## 8. EMI Reduction Method During Compliance Testing

No modification was made during testing.

## Attachment 1: EUT Test Photographs

## Attachment 2: EUT Detailed Photographs