

Application
For
Certification

Two Way Radio with FRS

FCC ID: PQN70437
For
Spin Master Toys Far East Ltd

IC: 4438B-15211
For
Spin Master Toys

13030588HKG-001
MN/ cl
May 13, 2013

- The test report only allows to be revised the retention period issued date unless further standard or the requirement was noticed.
- This report is for the exclusive use of Intertek's Client and is provided pursuant to the agreement between Intertek and its Client. Intertek's responsibility and liability are limited to the terms and conditions of the agreement. Intertek assumes no liability to any party, other than to the Client in accordance with the agreement, for any loss, expense or damage occasioned by the use of this report. Only the Client is authorized to permit copying or distribution of this report and then only in its entirety. Any use of the Intertek name or one of its marks for the sale or advertisement of the tested material, product or service must first be approved in writing by Intertek. The observations and test results in this report are relevant only to the sample tested. This report by itself does not imply that the material, product, or service is or has ever been under an Intertek certification program.

Intertek Testing Services Hong Kong Ltd.

2/F., Garment Centre, 576 Castle Peak Road, Kowloon, Hong Kong.
Tel: (852) 2173 8888 Fax: (852) 2785 5487 Website: www.hk.intertek-etlsemko.com

INTERTEK TESTING SERVICES

MEASUREMENT/TECHNICAL REPORT

FCC Applicant : **Spin Master Toys Far East Ltd.**
Trade Name/Model No : **70437**
6021605, 1029072, 1029260
Date : **May 13, 2013**

This report concerns (check one:) Original Grant Class II Change

Equipment Type: FRF – Part 95 Family Radio Face Held Transmitter

Deferred grant requested per 47 CFR 0.457(d)(1)(ii)? Yes No
If yes, defer until: _____
date

Company Name agrees to notify the Commission by: _____
date

of the intended date of announcement of the product so that the grant can be issued on that date.

Report prepared by: Nip Ming Fung, Melvin
Intertek Testing Services Hong Kong Ltd.
2/F., Garment Centre,
576 Castle Peak Road,
Kowloon, Hong Kong.
Phone: 852-2173-8535
Fax: 852-2741-1693

INTERTEK TESTING SERVICES

Table of Contents

1.0 General Description	4
1.1 Product Description	4
1.2 Related Submittal(s) Grants	5
1.3 Test Methodology	5
1.4 Test Facility	5
2.0 System Test Configuration	7
2.1 Justification	7
2.2 EUT Exercising Software	8
2.3 Special Accessories	8
2.4 Measurement Uncertainty	8
2.5 Equipment Modification	8
2.6 Support Equipment	8
3.0 RF Power Output (FCC Section 2.1046(a), 95.639(d) / RSS-210 A6.1.4)	10
4.0 Modulation Characteristics (FCC Section 2.1047(a)(b), 95.637(a))	14
4.1 Modulation Frequency Response	15
4.2 Modulation Limiting Characteristics	17
4.3 Audio Low Pass Filter Response	19
5.0 Occupied Bandwidth (FCC Section 95.633(c) / RSS-210 A6.1.3)	22
6.0 Spurious Emission (FCC Section 2.1053, 95.635(b) / RSS-210 A6.1.5)	25
6.1 Power of Spurious Radiation	26
7.0 Frequency Stability (FCC Section 2.1055(a)(b)(d), 95.627(b) / RSS-210 A6.1.6) ..	31
7.1 Frequency Tolerance	32
7.2 Temperature Extreme Condition	34
7.3 Voltage Extreme Condition	36
8.0 Equipment List	38

INTERTEK TESTING SERVICES

EXHIBIT 1

GENERAL DESCRIPTION

INTERTEK TESTING SERVICES

1.0 General Description

1.1 Product Description

The Equipment Under Test (EUT) is a Two Way Radio with FRS operating between 462.5625MHz and 467.7125MHz. The EUT is powered by 4.5V (3 x "AAA" size 1.5V alkaline batteries).

Transmitter Portion

- (i) Type of Emission : 5K80F3E
- (ii) Frequency Range : 14 Channels from 462.5625MHz to 467.7125MHz
- (iii) Maximum Power Rating : 0.04W ERP
- (iv) Antenna Type : Integral, vertically polarized with 0dBi gain
- (iv) dc voltage of radio frequency amplifying device : 1.5V
dc current of radio frequency amplifying device : 50mA

For FCC, the Model: 6021605, 1029072, 1029260 are the same as the Model: 70437 in electrical designs, including software & firmware, PCB layout and construction design/Physical design/Enclosure. The only differences between these models are model number and color to be sold for marketing purpose.

The brief circuit description is saved with filename: descri.pdf

INTERTEK TESTING SERVICES

1.2 Related Submittal(s) Grants

For FCC, this is an Application for Certification of the transmitter portion of a FRS Transceiver. The receiver section of this Transceiver and digital device portion is subject to verification process.

1.3 Test Methodology

Radiated emission measurements were performed according to the procedures in ANSI C63.4 (2003) and ANSI/TIA-603-C-2004. All radiated measurements were performed in Open Area Test Sites. Preliminary scans were performed in the Open Area Test Sites only to determine worst case modes. All radiated tests were performed at an antenna the EUT distance of 3 meters, unless stated otherwise in the “**Justification Section**” of this Application.

1.4 Test Facility

The open area test site used to collect the emission data is located at Garment Centre, 576 Castle Peak Road, Kowloon, Hong Kong. The test facility and site measurement data have been fully placed on file with the FCC & IC.

INTERTEK TESTING SERVICES

EXHIBIT 2

SYSTEM TEST CONFIGURATION

INTERTEK TESTING SERVICES

2.0 **System Test Configuration**

2.1 Justification

The device was configured for testing in a typical fashion (as a customer would normally use it). The device was placed on a turntable, which enabled the engineer to maximize emissions through its placement in the three orthogonal axes. The device has been tested with headset and without headset when the radiated emissions are measured.

The device was powered by 3 x new "AAA" size 1.5V alkaline batteries.

The following are all the test modes (only the worst-case was reported):

FRS, Tx without headset

FRS, Tx with headset

INTERTEK TESTING SERVICES

2.2 EUT Exercising Software

There was no special software to exercise the device. Once the PTT button was pushed, a signal was transmitted.

2.3 Special Accessories

No special accessory is needed for compliance of this device.

2.4 Measurement Uncertainty

When determining of the test conclusion, the Measurement Uncertainty of test has been considered.

Uncertainty and Compliance - Unless the standard specifically states that measured values are to be extended by the measurement uncertainty in determining compliance, all compliance determinations are based on the actual measured value and a consideration of that the uncertainty is within reasonable limits

2.5 Equipment Modification

No modifications by Spin Master Toys Far East Ltd. will be incorporated in each production model sold/leased in the United States.

2.6 Support Equipment

1. A headset with 1.2m unshielded cable. (Supplied by Client)
2. Operated Battery: 3 x "AAA" size 1.5V battery

Confirmed by:

*Nip Ming Fung, Melvin
Assistant Manager
Intertek Testing Services Hong Kong Ltd.*

_____ Signature

_____ May 13, 2013 Date

EXHIBIT 3
RF POWER OUTPUT

INTERTEK TESTING SERVICES

3.0 **RF Power Output (FCC Section 2.1046(a), 95.639(d) / RSS-210 A6.1.4)**

A. Equipment Used

Equipment	Brand Name	Model No.
Log Periodic Antenna	EMCO	3148
Spectrum Analyzer	AGILENTTECH	E4407B
EMI Test Receiver	ROHDESCHWARZ	ESCI
Tuned Dipole Antenna	CDI	A100
Signal Generator	AGILENTTECH	E8247C

B. Testing Procedure

1. On a test site, the EUT shall be placed at 0.8m height on a wooden turntable, and in the position closest to normal use as declared by the applicant.
2. The test antenna shall be oriented initially for vertical polarisation located 3m from EUT to correspond to the frequency of the transmitter.
3. The output of the test antenna shall be connected to the measuring receiver and the peak detector is used for the measurement.
4. The transmitter shall be switched on, if possible, without modulation and the measuring receiver shall be tuned to the frequency of the transmitter under test.
5. The test antenna shall be raised and lowered through the specified range of height until a maximum signal level is detected by the measuring receiver.

INTERTEK TESTING SERVICES

6. The transmitter shall then be rotated through 360° in the horizontal plane, until the maximum signal level is detected by the measuring receiver.
7. The test antenna shall be raised and lowered again through the specified range of height until a maximum signal level is detected by the measuring receiver.
8. The maximum signal level detected by the measuring receiver shall be noted.
9. The transmitter shall be replaced by a tuned dipole (substitution antenna).
10. The substitution antenna shall be orientated for vertical polarisation and the length of the substitution antenna shall be adjusted to correspond to the frequency of the transmitter.
11. The substitution antenna shall be connected to a calibrated signal generator.
12. If necessary, the input attenuator setting of the measuring receiver shall be adjusted in order to increase the sensitivity of the measuring receiver.
13. The test antenna shall be raised and lowered through the specified range of height to ensure that the maximum signal is received.
14. The input signal to the substitution antenna shall be adjusted to the level that produces a level detected by the measuring receiver, that is equal to the level noted while the transmitter radiated power was measured, corrected for the change of input attenuator setting of the measuring receiver.
15. The input level to the substitution antenna shall be recorded as power level in dBm, corrected for any change of input attenuator setting of the measuring receiver.
16. The measurement shall be repeated with the test antenna and the substitution antenna orientated for horizontal polarisation.
17. The measure of the effective radiated power is the larger of the two levels recorded, at the input to the substitution antenna, corrected for gain of the substitution antenna if necessary.

INTERTEK TESTING SERVICES

Table 1

Transmission Power

Channel	Frequency (MHz)	Effective Radiated Power		FCC 95.639 Limit (W)	Margin (W)	RSS-210 Limit (W)	Margin (W)
		(dBm)	(W)				
1	462.5625	15.8	0.04	0.5	-0.46	0.5	-0.46
2	462.5875	15.8	0.04	0.5	-0.46	0.5	-0.46
3	462.6125	15.8	0.04	0.5	-0.46	0.5	-0.46
4	462.6375	15.8	0.04	0.5	-0.46	0.5	-0.46
5	462.6625	15.8	0.04	0.5	-0.46	0.5	-0.46
6	462.6875	15.8	0.04	0.5	-0.46	0.5	-0.46
7	462.7125	15.8	0.04	0.5	-0.46	0.5	-0.46
8	467.5625	15.8	0.04	0.5	-0.46	0.5	-0.46
9	467.5875	15.8	0.04	0.5	-0.46	0.5	-0.46
10	467.6125	15.8	0.04	0.5	-0.46	0.5	-0.46
11	467.6375	15.8	0.04	0.5	-0.46	0.5	-0.46
12	467.6625	15.8	0.04	0.5	-0.46	0.5	-0.46
13	467.6875	15.8	0.04	0.5	-0.46	0.5	-0.46
14	467.7125	15.8	0.04	0.5	-0.46	0.5	-0.46

Notes: Negative sign in the margin column shows the value below limits.

Verdict: Passed

Test Engineer: Koo Wai Ip

Date of Test: April 05, 2012

INTERTEK TESTING SERVICES

EXHIBIT 4

MODULATION CHARACTERISTICS

INTERTEK TESTING SERVICES

4.0 Modulation Characteristics (FCC Section 2.1047(a)(b), 95.637(a))

In order to satisfy the 95.637(a) and 2.1047(b) requirements, Modulation Frequency Response and Modulation Limiting Characteristics are attached in Exhibit 4.1 & 4.2.

In order to satisfy the 2.1047(a) requirement, Audio Low Pass Filter Response is attached in Exhibit 4.3.

For electronic filing, the modulation frequency response curve and modulation limiting characteristic curve are saved with filename: mfr.pdf and mlc.pdf respectively.

For electronic filing, the audio low pass frequency response curve is saved with filename: lpf.pdf.

INTERTEK TESTING SERVICES

4.1 Modulation Frequency Response (FCC Section 2.1047(a), 95.637(a))

A. Test Equipment

Equipment	Brand Name	Model No.
Function Generator	GRUNDIG	FG100
AC Millivoltmeter	Leader	LMV-182A
20 dB RF Attenuator	Bird	8304-200-N
Radiocommunication Service Monitor	R&S	CMS54

B. Testing Procedure

- 1) Set-up the test equipment in the following configuration:

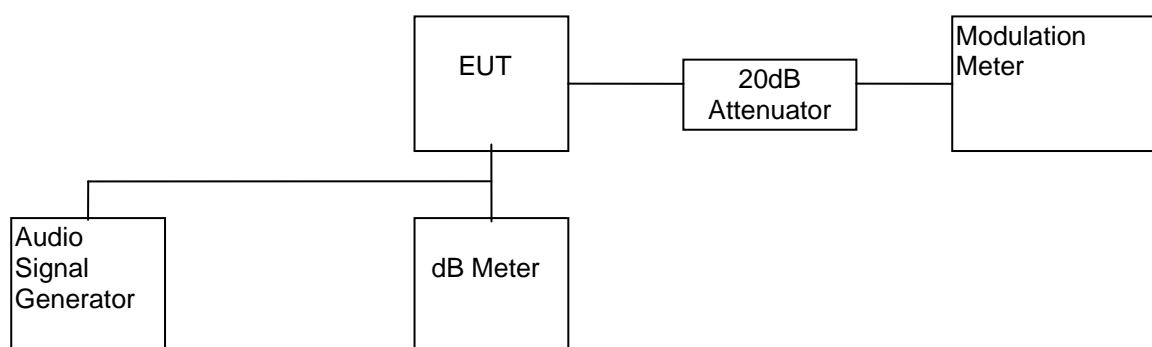

- 2) Set the audio signal generator frequency to the sound pressure level 127dB SPL at the microphone of the EUT.
- 3) The frequency of the audio signal generator is changed from 100Hz to 5kHz.
- 4) Record the frequency deviation.
- 5) The peak frequency deviation must not exceed:

$$\text{FRS} : \pm 2.5\text{kHz}$$

- 6) Calculate the audio frequency response at each frequency as:

$$\text{response} = 20 \log_{10}(\text{DEV}_{\text{FREQ}} / \text{DEV}_{\text{REF}});$$

DEV_{REF} = Frequency deviation at 1000Hz ;

DEV_{FREQ} = Frequency deviation at 100 - 5000Hz ;

- 7) From the plot, audio frequency response rolls off before 3.125kHz.

INTERTEK TESTING SERVICES

C. Test Result

Table 2

Modulation Frequency Response

Test Channel : 4
Input level = 112 dBSPL

Modulation Frequency(Hz)	Frequency Deviation(kHz)	Audio Frequency Response = 20 log ₁₀ (DEV FREQ/ DEV REF)
100	0.186	-21.96
200	1.560	-3.49
300	1.670	-2.90
400	2.135	-0.76
500	2.342	0.04
600	2.221	-0.42
700	2.361	0.11
800	2.391	0.22
900	2.481	0.54
1000	2.331	0.00
1250	2.444	0.41
1500	2.462	0.47
1750	2.322	-0.03
2000	2.344	0.05
2250	2.063	-1.06
2500	1.923	-1.67
2750	1.722	-2.63
3000	1.518	-3.73
3125	1.501	-3.82
3250	1.491	-3.88
3500	1.248	-5.43
4000	1.015	-7.22
5000	0.710	-10.33

Verdict: Passed

Test Engineer: Koo Wai Ip

Date of Test: March 26, 2013

INTERTEK TESTING SERVICES

4.2 Modulation Limiting Characteristics (FCC Section 2.1047(b), 95.637(a))

A. Test Equipment

Equipment	Brand Name	Model No.
Function Generator	GRUNDIG	FG100
20 dB RF Attenuator	Bird	8304-200-N
Radiocommunication Service Monitor	R&S	CMS54

B. Testing Procedure

- 1) Set-up the test equipment in the following configuration:

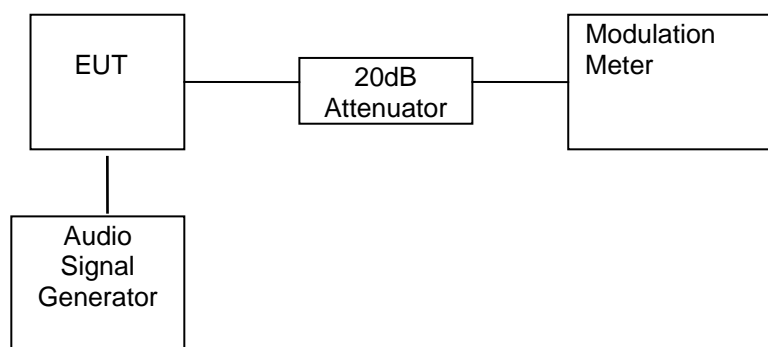

- 2) Set the frequency of the audio signal generator to 500Hz and adjust the level from 47dB SPL to 137dB SPL.
- 3) Record the maximum value of plus or minus peak frequency deviation.
- 4) Repeat the above procedure with frequency 1000Hz, 2500Hz & 3125Hz.
- 5) The peak frequency deviation must not exceed:

FRS : $\pm 2.5\text{kHz}$

INTERTEK TESTING SERVICES

C. Test Result

Table 3

Modulation Limiting Characteristics

Test Channel : 4

Modulation Input (dB SPL)	Peak Frequency Deviation (kHz) at 500Hz	Peak Frequency Deviation (kHz) at 1000Hz	Peak Frequency Deviation (kHz) at 2500Hz	Peak Frequency Deviation (kHz) at 3125Hz
47	0.138	0.488	0.111	0.101
57	0.141	0.520	0.128	0.154
67	0.143	0.489	0.145	0.145
77	0.143	0.512	0.143	0.144
87	0.145	0.615	0.185	0.135
97	0.647	1.342	1.024	0.824
107	1.324	2.497	2.260	1.625
117	2.357	2.456	2.062	1.369
127	2.421	2.493	2.032	1.256
137	2.422	2.492	2.132	1.342

Verdict: Passed

Test Engineer: Koo Wai Ip

Date of Test: March 26, 2013

INTERTEK TESTING SERVICES

4.3 Audio Low Pass Filter Response (FCC Section 2.1047(a), 95.637(b))

A. Test Equipment

Equipment	Brand Name	Model No.
Function Generator	GRUNDIG	FG100
Radiocommunication Service Monitor	R&S	CMS54

B. Testing Procedure

- 1) Connect the audio signal generator to the input of the post limiter low pass filter and the dB meter to the output of the post limiter low pass filter.
- 2) Apply a 1000 Hz tone from the audio signal generator and adjust the level per manufacturer's specifications. Record the dB level of the 1000 Hz tone as LEV_{REF} .
- 3) Set the audio signal generator to the desired test frequency between 3000 Hz and the upper low pass filter limit. Record the dB level at the test frequency as LEV_{FREQ} .
- 4) Calculate the audio frequency response at the test frequency as:

$$\text{low pass filter response} = LEV_{FREQ} - LEV_{REF}$$

- 5) Repeat the above procedure for all the desired test frequencies.

INTERTEK TESTING SERVICES

C. Test Result

Table 4

Low-Pass Filter Response

Test Channel : 4

Audio Input Strength = 500mVrms

Frequency (kHz)	dB relative to 1 kHz	TIA/EIA-603C
1	0.0	0.0
3	-7.0	0.0
4	-11.0	-7.5
5	-15.0	-13.3
6	-19.0	-18.1
8	-26.0	-25.6
10	-32.0	-31.4
15	-44.0	-41.9
20	-52.0	-50.0
30	-59.0	-50.0
40	-60.0	-50.0
50	-56.0	-50.0
60	-60.0	-50.0
70	-60.0	-50.0
80	-56.0	-50.0
90	-58.0	-50.0
100	-66.0	-50.0

Audio Output at 1kHz: -18.0dBV

Verdict: Passed

Test Engineer: Koo Wai Ip

Date of Test: April 23, 2013

INTERTEK TESTING SERVICES

EXHIBIT 5

OCCUPIED BANDWIDTH

INTERTEK TESTING SERVICES

5.0 Occupied Bandwidth (FCC Section 2.1049, 95.633(c) / RSS-210 A6.1.3)

A. Test Equipment

Equipment	Brand Name	Model No.
Function Generator	GRUNDIG	FG100
AC Millivoltmeter	Leader	LMV-182A
20 dB RF Attenuator	Bird	8304-200-N
Spectrum Analyzer	ROHDESCHWARZ	FSP30

B. Testing Procedure

- 1) Set-up the test equipment in the following configuration:

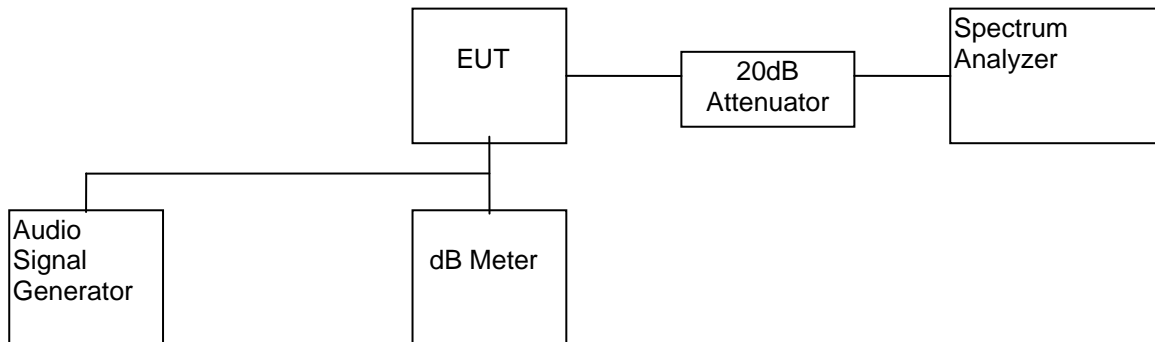

- 2) Set the level of audio signal generator to obtain 16 dB greater than required for 50% modulation.
- 3) The occupied bandwidth is measured with the spectrum analyzer set at 2kHz/div scan and 10dB/div.

INTERTEK TESTING SERVICES

C. Test Result

Table 5

System	Channel	Measured Bandwidth (kHz)	Limit (kHz)
FRS	4	5.80	≤12.5

Verdict: Passed

For the electronic filing, the bandwidth plot is saved with filename: bw.pdf

Test Engineer: Koo Wai Ip

Date of Test: March 23, 2013

INTERTEK TESTING SERVICES

EXHIBIT 6

SPURIOUS EMISSION

INTERTEK TESTING SERVICES

6.0 **Spurious Emission (FCC Section 2.1053, 95.635(b) / RSS-210 A6.1.5)**

The spurious emission from the EUT are measured and shown in the Exhibit 6.1.

INTERTEK TESTING SERVICES

6.1 Power of Spurious Radiation

A. Test Equipment

Equipment	Brand Name	Model No.
Antenna	EMCO	A100, 3148, 3104C, 3115
Spectrum Analyzer	AGILENTTECH	E4407B
RF Filter	Trilithic	3VF500/1000-5-50-CC
Signal Generator	AGILENTTECH	E8247C
EMI Test Receiver	ROHDESCHWARZ	ESCI

B. Testing Procedure

Radiated emission measurements were performed according to the procedures in ANSI/TIA-603-C-2004. All measurements were performed in Open Area Test Sites located at Roof Top of Garment Centre, 576 Castle Peak Road, Kowloon, Hong Kong.

INTERTEK TESTING SERVICES

C. Radiated Emission Configuration Photograph

Worst Case Radiated Emission

For electronic filing, the radiated emission configurations photograph is saved with filename: config photos.pdf

INTERTEK TESTING SERVICES

C. Test Result

Table 6(a)

1) Unwanted emission from CARRIER $\pm 6.25\text{kHz}$ to CARRIER $\pm 31.25\text{kHz}$

(Refer to the plots which is saved with filename: spurious.pdf)

Region	Unwanted emission
	Channel 4
CARRIER $\pm 6.25\text{kHz}$ to $\pm 12.5\text{kHz}$	<25dB
CARRIER $\pm 12.5\text{kHz}$ to $\pm 31.25\text{kHz}$	<35dB

INTERTEK TESTING SERVICES

Table 6(b): Channel 4

Frequency (MHz)	Effective Radiated Power (dBm)	Transmission Power (dBm)	Attenuation (dBc)	Limit (dBc)	Margin (dB)
925.274	-18.0	15.8	33.8	28.8	-5.0
1387.911	-13.3	15.8	29.1	28.8	-0.3
1850.548	-22.0	15.8	37.8	28.8	-9.0
2313.185	-16.4	15.8	32.2	28.8	-3.4
2775.822	-15.0	15.8	30.8	28.8	-2.0
3238.459	-27.2	15.8	43.0	28.8	-14.2
3701.096	-26.0	15.8	41.8	28.8	-13.0
4163.733	-24.2	15.8	40.0	28.8	-11.2
4626.371	-26.3	15.8	42.1	28.8	-13.3

- Remark: 1. Transmission power is 15.8 dBm or -14.2 dB(W).
2. According to Section 95.635(b7) / RSS-210 A6.1.5, the unwanted emission should be attenuated below TP by at least $43 + 10 \log_{10} (TP)$ dB or 28.8 dB.
3. The test is performed according to ANSI/TIA-603-C-2004.

Verdict: Passed

Test Engineer: Koo Wai Ip

Date of Test: April 15, 2013

EXHIBIT 7

FREQUENCY STABILITY

INTERTEK TESTING SERVICES

7.0 Frequency Stability (FCC Section 2.1055(a)(b)(d), 95.627(b) / RSS-210 A6.1.6)

The frequency tolerance was tested in normal condition & over extreme ambient conditions with respect to voltage and temperature variation.

INTERTEK TESTING SERVICES

7.1 Frequency Tolerance (FCC Section 95.627(b) / RSS-210 A6.1.6)

A. Test Equipment

Equipment	Brand Name	Model No.
20 dB RF Attenuator	Bird	8304-200-N
Frequency Counter	OPTOELECTRONICS	3000A

B. Testing Procedure

- 1) Set-up the test equipment in the following configuration:

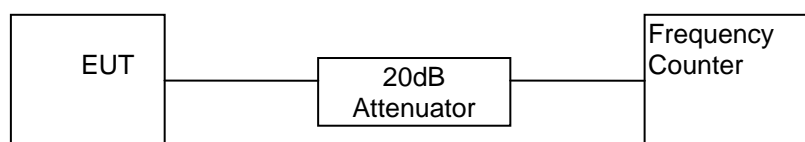

- 2) Measure all transmit channel frequencies in MHz.

INTERTEK TESTING SERVICES

C. Test Result

Table 7

Frequency Tolerance

Channel	Frequency (MHz)	Measured Frequency (MHz)	Tolerance (%)
1	462.5625	462.56300	0.000108
2	462.5875	462.58799	0.000106
3	462.6125	462.61298	0.000104
4	462.6375	462.63817	0.000145
5	462.6625	462.66296	0.000099
6	462.6875	462.68795	0.000097
7	462.7125	462.71293	0.000093
8	467.5625	467.56292	0.000090
9	467.5875	467.58781	0.000066
10	467.6125	467.61290	0.000086
11	467.6375	467.63789	0.000083
12	467.6625	467.66288	0.000081
13	467.6875	467.68788	0.000081
14	467.7125	467.71287	0.000079

FCC Limit for FRS (95.627(b)): $\leq \pm 0.00025\%$

RSS-210 Limit for FRS (A6.1.6): $< \pm 0.0005\%$

Verdict: Passed

Test Engineer: Koo Wai Ip

Date of Test: March 26, 2013

INTERTEK TESTING SERVICES

7.2 Frequency Stability - Temperature (FCC Section 2.1055(a)(b), 95.627(b) / RSS-210 A6.1.6)

A. Test Equipment

Equipment	Brand Name	Model No.
20 dB RF Attenuator	Bird	8304-200-N
Frequency Counter	OPTOELECTRONICS	3000A

B. Testing Procedure

- 1) Set-up the test equipment in the following configuration:

Temperature Chamber

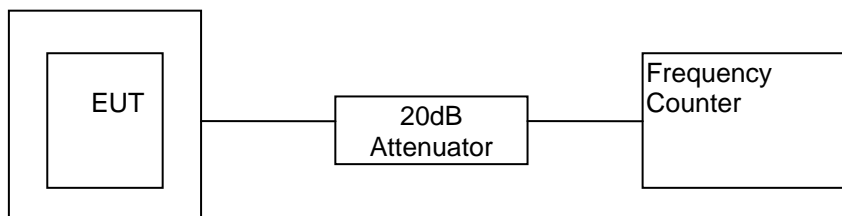

- 2) Set the Temperature Chamber to 20°C and stabilize the EUT temperature for one hour. Set transmitter ON for two minutes.
- 3) Measure the channel frequency of channel 4 in MHz.
- 4) Turn the EUT OFF.
- 5) Repeat the above procedure from -30°C to 50°C with 10°C increment.

INTERTEK TESTING SERVICES

C. Test Result

Table 8(a)

Frequency Tolerance with Temperature Variation

Channel : 4

Temperature (°C)	Assigned Frequency (MHz)	Measured Frequency (MHz)	Tolerance (%)	*Frequency Tolerance with reference to its value at +20°C (ppm)
-20	462.63750	462.63730	-0.000043	-1.9
-10	462.63750	462.63759	0.000019	-1.3
0	462.63750	462.63829	0.000171	0.3
10	462.63750	462.63841	0.000197	0.5
20	462.63750	462.63817	0.000145	0.0
30	462.63750	462.63779	0.000063	-0.8
40	462.63750	462.63745	-0.000011	-1.6
50	462.63750	462.63769	0.000041	-1.0

Remark: 1) For FRS, frequency tolerance must be maintained within a frequency tolerance of 0.00025%

Verdict: Passed

Test Engineer: Koo Wai Ip

Date of Test: March 26, 2013

INTERTEK TESTING SERVICES

7.3 Frequency Stability - Voltage (FCC Section 2.1055(d), 95.627(b) / RSS-210 A6.1.6)

A. Test Equipment

Equipment	Brand Name	Model No.
Regulated Power Supply	PAD	30-35L
20 dB RF Attenuator	Bird	8304-200-N
Voltage meter	Fluke	87
Frequency Counter	OPTOELECTRONICS	3000A

B. Testing Procedure

- 1) Set-up the test equipment in the following configuration:

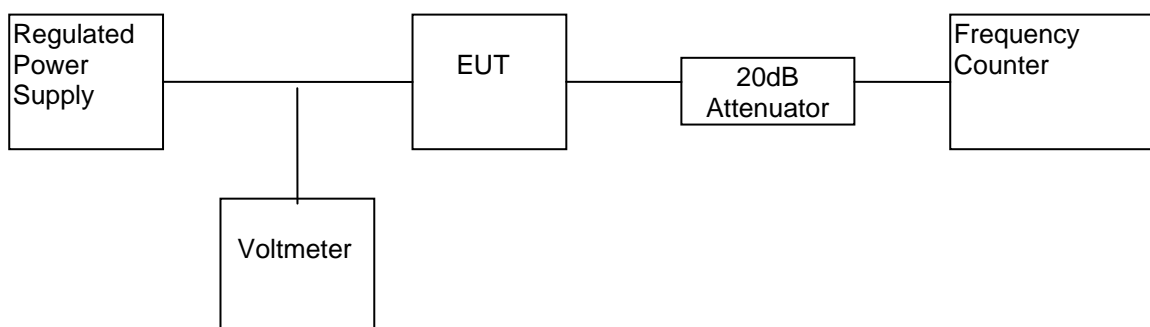

- 2) Vary the level of regulated power supply to the manufacturer specified battery end point of the EUT.
- 3) Measure the channel frequency of channel 4 in MHz.

INTERTEK TESTING SERVICES

C. Test Result

Table 9

Frequency Deviation with Voltage Variation

The manufacturer specified battery end point 2.7V

Channel	Frequency (MHz)	Measured Frequency (MHz)	Tolerance (%)
4	462.63750	462.63752	0.000004

Remark: 1) For FRS, frequency tolerance must be maintained within a frequency tolerance of 0.00025%.

2) The test voltage is from primary supply voltage to 2.7V

Test Engineer: Koo Wai Ip

Date of Test: March 26, 2013

INTERTEK TESTING SERVICES

8.0 Equipment List

1) Radiated Emissions Test

Equipment	EMI Test Receiver	Spectrum Analyzer (9kHz to 26.5GHz)	Biconical Antenna
Registration No.	EW-2500	EW-2188	EW-0571
Manufacturer	ROHDESCHWARZ	AGILENTTECH	EMCO
Model No.	ESCI	E4407B	3104C
Calibration Date	Mar. 22, 2013	Nov. 05, 2012	Apr. 05, 2012
Calibration Due Date	Feb. 28, 2014	Nov. 05, 2013	Oct. 05, 2013

Equipment	Log Periodic Antenna	Roberts Antennas	Roberts Antennas
Registration No.	EW-0446	EW-0159	EW-0160
Manufacturer	EMCO	CDI	CDI
Model No.	3146	A100	A100
Calibration Date	Oct. 31, 2011	Sep. 25, 2012	Sep. 25, 2012
Calibration Due Date	Apr. 30, 2013	Mar. 25, 2014	Mar. 25, 2014

Equipment	Double Ridged Guide Antenna (1GHz - 18GHz)	Signal Generator (250kHz to 40GHz)
Registration No.	EW-1133	EW-1983
Manufacturer	EMCO	AGILENTTECH
Model No.	3115	E8247C
Calibration Date	Oct. 05, 2012	Apr. 12, 2013
Calibration Due Date	Apr. 05, 2014	Apr. 12, 2015

INTERTEK TESTING SERVICES

2) Other RF Measurement Test

Equipment	Communication Service Monitor (Radio)	Frequency Counter	Function Generator
Registration No.	EW-1443	EW-1069	EW-2775
Manufacturer	ROHDESCHWARZ	OPTOELECTRON	AGILENTTECH
Model No.	CMS54	3000A/TCXO	33210A
Calibration Date	May. 10, 2012	Apr. 18, 2012	Aug. 28, 2012
Calibration Due Date	May. 10, 2013	Apr. 18, 2013	Sep. 28, 2013

Equipment	Spectrum Analyzer
Registration No.	EW-2466
Manufacturer	ROHDESCHWARZ
Model No.	FSP30
Calibration Date	Jul. 16, 2012
Calibration Due Date	Jul. 16, 2013

INTERTEK TESTING SERVICES

APPENDIX

EXHIBITS OF APPLICATION FOR CERTIFICATION