

CARE AND MAINTENANCE: Always remove batteries from the toy when it is not being used for a long period of time (controller only). Wipe the toy gently with a clean damp cloth. Keep the toy away from direct heat. Do not submerge the toy in water. This can damage the electronic assemblies.

BATTERY SAFETY INFORMATION: Requires LiFe 9.6V/700mAh battery (included) and 2 x 1.5 V AAA (LR03) batteries (not included). Batteries are small objects. Replacement of batteries must be done by adults. Follow the polarity (+/-) diagram in the battery compartment. Promptly remove dead batteries from the toy. Dispose of used batteries properly. Remove batteries for prolonged storage. Only batteries of the same or equivalent type as recommended are to be used. DO NOT incinerate used batteries. DO NOT dispose of batteries in fire, as batteries may explode or leak. DO NOT mix old and new batteries or types of batteries (i.e. alkaline/standard/rechargeable). Using rechargeable batteries is not recommended due to possible reduced performance. Rechargeable batteries are only to be charged under adult supervision. Replaceable-rechargeable batteries are to be removed from the toy before being charged. DO NOT recharge non-rechargeable batteries. DO NOT short-circuit the supply terminals.

FCC STATEMENT: This device complies with Part 15 of the FCC rules. Operation is subject to the following two conditions: (1) This device may not cause harmful interference, and (2) This device must accept any interference received, including interference that may cause undesired operation. This equipment has been tested and found to comply with the limits for Class B digital devices pursuant to Part 15 of the FCC rules. These limits are designed to provide reasonable protection against harmful interference to radio communications. This equipment generates, uses and can radiate radio frequency energy and, if not installed and used in accordance with the instruction, may cause harmful interference to radio communication. However, there is no guarantee that interference will not occur in a particular installation. If this toy does cause interference to radio or television reception (you can check this by turning the toy off and on while listening for the interference), one or more of the following measures may be useful:



- Reorient or relocate the receiving antenna.
- Increase the separation between the toy and the radio or the TV.
- Consult the dealer or an experienced TV-radio technician for help.
- Shielded cables must be used with this unit to ensure compliance with the Class B FCC limits.

NOTE: Changes, adjustments or modifications to this unit, including but not limited to, replacement of any transmitter component (crystal, semiconductor, etc) could result in a violation of FCC rules under part 15 and/or 95 and must be expressly approved by Spin Master Ltd or they could void the user's authority to operate the equipment. Spin Master Inc., PMB #10053, 300 International Drive, Suite 100, Williamsville, NY 14221. To contact the responsible party please visit fcc.spinmaster.com

Do not change or modify anything on the toy.

BEFORE FIRST USE: Read the user's information together with your child.

SPIN MASTER LTD., 225 KING STREET WEST, TORONTO, ON M5V 3M2 CANADA
 Imported into EU by SPIN MASTER INTERNATIONAL, B.V., Kingsfordweg 151, 1043 GR Amsterdam, The Netherlands
 Spin Master logo & © Spin Master Ltd. All rights reserved. Retain this information, addresses and phone numbers for future reference. Keep away from obstacles and electrical hazards.
 Spin Master Ltd. reserves the right to discontinue the www.monsterjamrc.com website at any time. **MADE IN CHINA**
 Imported by Spin Master Australia Pty Ltd, Suite 101, Level 1, 18-24 Chandos Street, St Leonards, NSW 2065; ☎1800 316 982

 **Battery requirement for toy**
Power Supply: 
Rating: 9.6V 700mAh
Battery: 1 x 9.6V 700mAh LiFePO4 Rechargeable Battery Pack
Requires: 1 x 9.6V 700mAh LiFePO4 Rechargeable Battery Pack

Battery requirement for controller
Power Supply: 
Rating: DC 3 V, 0.45 W
Batteries: 2 x 1.5 V AAA (LR03)
Requires 2 x 1.5 V AAA size batteries (not included)

MONSTER JAM **MEGA GRAVE DIGGER**

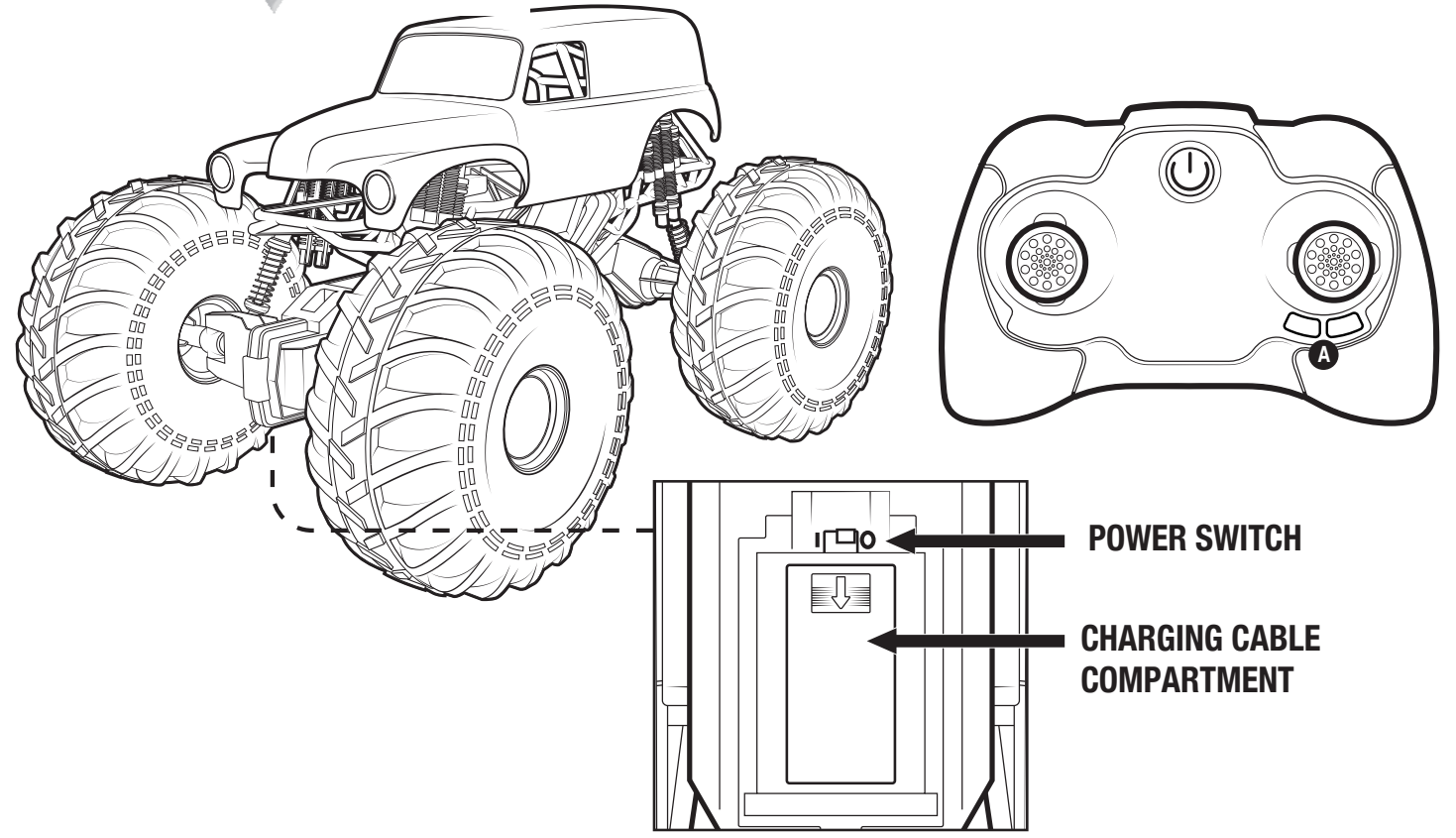

Caution not a Ride-On Toy. Not intended to bear weight of children.

CONTENTS

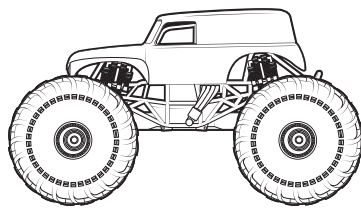
 1 x Grave Digger

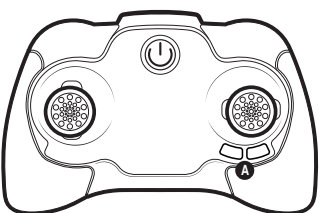
 1 x Controller

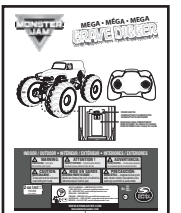
 1 x Instruction Guide

For in-depth video instructions go to
MONSTERJAMRC.COM

© 2019 Feld Motor Sports, Inc. MONSTER JAM®, UNITED STATES HOT ROD ASSOCIATION, GRAVE DIGGER are trademarks of and used under license by FMS. All rights reserved.

Spin Master International B.V. hereby declares that the radio equipment type MONSTER JAM MEGA GRAVE DIGGER™ is in compliance with Directive 2014/53/EU. The full text of the EU declaration of conformity is available at the following internet address: <http://doc.spinmaster.com>
 T66804_0001_20105999_GEN_IS_R4

Frequency Band(s): 2.420 GHz – 2.465 GHz
Maximum radio frequency power transmitted: Below 10dBm

WARNING: CHOKING HAZARD – Small parts.

CAUTION:
HAIR ENTANGLEMENT –
 Tie back and cover hair and secure loose clothing prior to play.

INDOOR / OUTDOOR
WWW.SPINMASTER.COM

NORTH AMERICA • AMÉRIQUE DU NORD
 1-800-622-8339, customercare@spinmaster.com
UK – 0800 206 1191, serviceuk@spinmaster.com
 IRELAND – 1800 992 249
FRANCE – 0800 909 150, servicefr@spinmaster.com
AUSTRALIA – 1800 316 982, customercare@spinmaster.com
MÉXICO – 55 4160 7947, servicio@spinmaster.com

WWW.SPINMASTER.COM

BC 4+ YRS

2xAAA (LR03)^{1.5V}
Not Included



WWW.MONSTERJAMRC.COM

HOW TO INSTALL BATTERIES

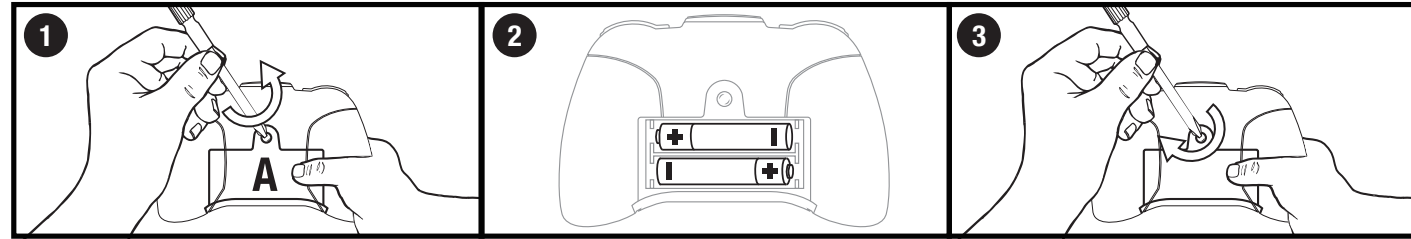

1. Open the battery door with a screwdriver. (A). If used batteries are present, remove these batteries from the unit by pulling up on one end of each battery. DO NOT remove or install batteries using sharp or metal tools.
2. Install new batteries as shown in the polarity diagram (+/-) inside the battery compartment.
3. Replace battery door securely. Check your local laws and regulations for correct recycling and/or battery disposal.

HOW TO CHARGE

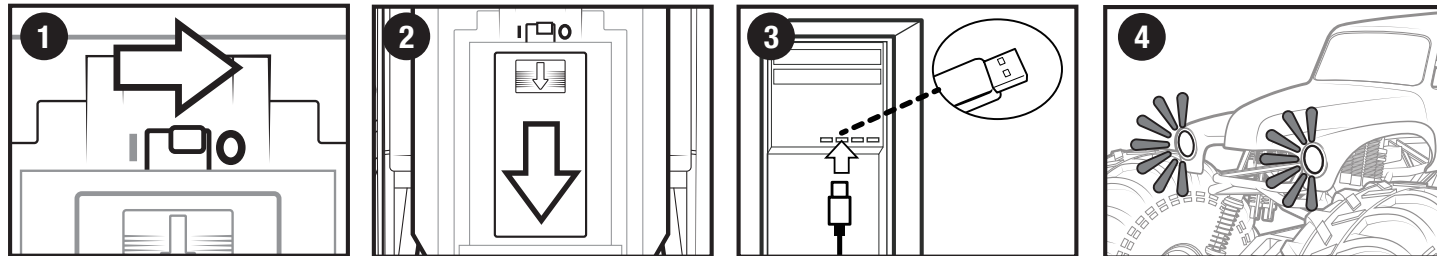

1. Turn the vehicle off.
2. Remove the cover from the charging cable compartment.
3. Plug the charging cable into a computer or wall adapter. Only connect USB charging cable to a computer or other 5VDC rated power source.
4. Headlights indicate charging. Blinking for charging and ON when fully charged.

HOW TO DRIVE

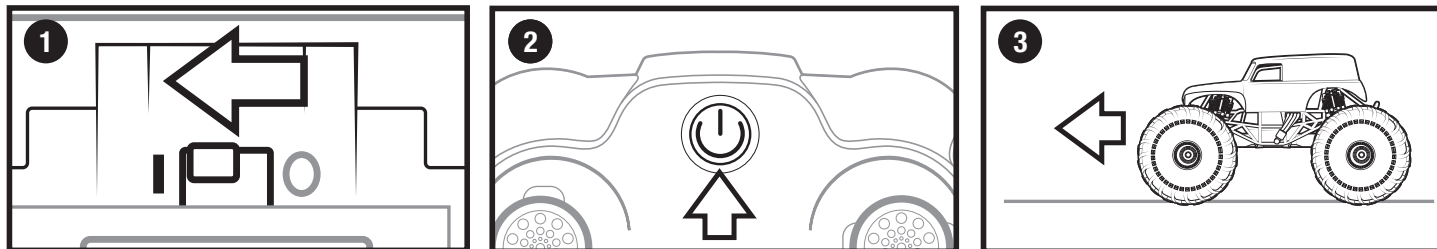

1. Turn on the vehicle and place on a flat surface.
2. Hold the controller near your truck, press the power button wait until power light stops flashing.
3. You are ready to drive.
4. Use the remote control to drive.

TROUBLESHOOTING

NOTE: If your truck does not connect to the controller the first time, turn the truck off, take the batteries out of the controller and repeat STEP 1.

DIRECTIONAL CONTROL

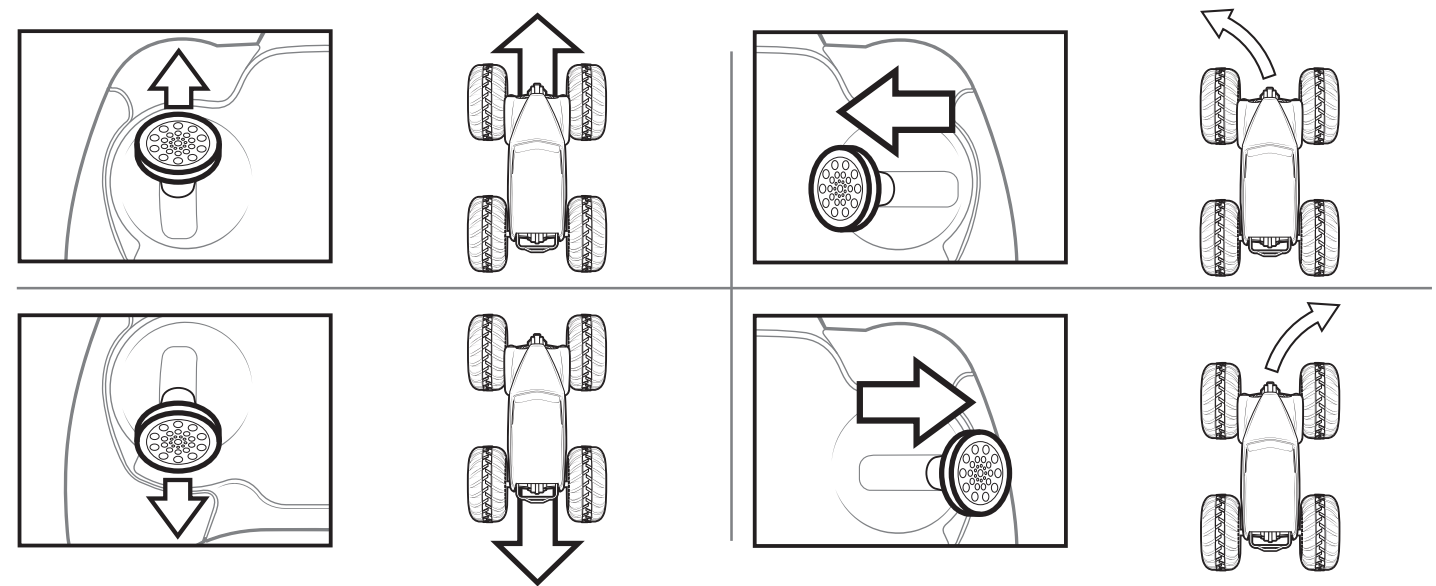

HOW TO FIX DRIFTING

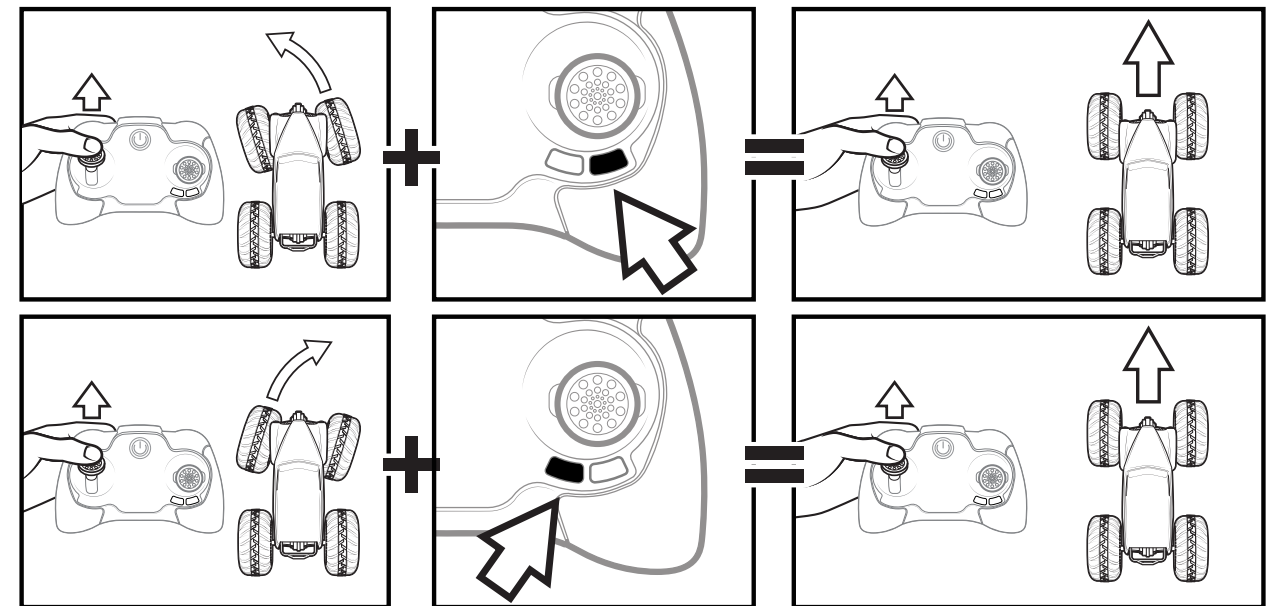

EN For TROUBLESHOOTING questions and solutions, please visit our website: MONSTERJAMRC.COM

NOTE: If normal function of the product is disturbed or interrupted, strong electromagnetic interference may be causing the issue. To reset product, turn it completely off, then turn it back on. If normal operation does not resume, move the product to another location and try again. To ensure normal performance, change the batteries, as low batteries may not allow full function.

Safety Precautions: - Keep hands, hair and loose clothing away from the motor/ wheels when power switch is turned ON. - Remove battery(s) from controller when not in use. - Parental guidance is recommended for the play. - Keep your toy in your sight so that you can supervise it all the time. - New alkaline batteries are recommended for use in controller to obtain maximum performance. - Users should keep strict accordance with the instruction manual while operating the product. - Your controller/charger is tailor-made for the LiFePO4 rechargeable battery used in your vehicle. Do not use it to charge any battery other than that in the toy. **Note:** Parental guidance is recommended when installing or replacing batteries. Under the environment with electrostatic discharge, the toy may malfunction and require user to reset the toy.

Special note to adults: Regularly examine for damage to the plug, enclosure and other parts. In the event of any damage, the toy must not be used with the charger until the damage has been repaired. This toy is not intended for children under 3 years old. This toy must only be used with the recommended charger.

CONTAINS 1 X 9.6V LiFe BATTERY PACK AND REQUIRES 2 x 1.5V AAA (LR03) ALKALINE BATTERIES. (Not Included)
Batteries or battery packs must be recycled or disposed of properly. When this product has reached the end of its useful life, it should not be disposed of with other household waste. The Waste Electrical and Electronic Equipment Regulations require it to be separately collected so that it can be treated using the best available recovery and recycling techniques. This will minimize the impact on the environment and human health from soil and water contamination by any hazardous substances, decrease the resources required to make new products and avoid using up landfill space. Please do your part by keeping this product out of the municipal waste stream! The "wheelie bin" symbol means that it should be collected as "waste electrical and electronic equipment". You can return an old product to your retailer when you buy a similar new one. For other options, please contact your local council.

PRODUCT BATTERY REMOVAL INSTRUCTIONS:
Internal battery is factory installed and non-replaceable. Product disassembly and battery removal must be performed by an adult. Do not puncture, cut, tear, compress or deform product during disassembly. Ensure product is turned off, then use a screw driver to remove screw. Lift end of battery compartment and slide out battery. Dispose of battery in accordance with your local battery recycling or disposal laws.

NOTE: Opening of product will render product inoperative and voids manufacturer warranties. Dispose of remaining product components in accordance with local laws.

This toy is equipped with a Lithium-ion battery.

SPECIAL LiFe BATTERY INSTRUCTIONS: Never charge battery unattended. - Charge battery in an isolated area. Keep away from flammable materials. - Do not expose to direct sunlight. There is a risk of the batteries exploding, overheating, or igniting. - Do not disassemble, modify, heat, or short-circuit the batteries. Do not place them in fires or leave them in hot places. - Do not drop or subject to strong impacts. - Do not allow the batteries to get wet. - Only charge the batteries with the specified Spin Master™ battery charger. - Only use the batteries in the device specified by Spin Master™. - Carefully read the instruction guide and use the batteries correctly. - In the unlikely event of leakage or explosion use sand or a chemical fire extinguisher for the battery. - Batteries must be recycled or disposed of properly.

Monster Jam Parts Warranty – 1 Year Replacement Parts

Free replacement parts 1 year from the date of purchase. Contact our consumer care
1-800-622-8339 for more information.