

## TEST REPORT

**Report No.: 22050961HKG-003R1**

Spin Master Toys Far East Ltd.

Application For Certification  
(Original Grant)

**FCC ID: PQN66803RX2G42**

Transceiver – 2.4GHz RC Car

This report supersedes previous report with report number 22050961HKG-003 dated July 29, 2022.  
Please refer TY-S22-0092 Letter issued on August 18, 2022 for amendment/ supersede notification.

**Prepared and Checked by:**

**Approved by:**

Signed on File  
Leung Chun Ning, Peter  
Assistant Engineer

---

Wong Kwok Yeung, Kenneth  
Assistant Supervisor  
Date: August 18, 2022

---

Intertek's standard Terms and Conditions can be obtained at our website <http://www.intertek.com/terms/>.

The test report only allows to be revised within the retention period unless further standard or the requirement was noticed.

This report is for the exclusive use of Intertek's Client and is provided pursuant to the agreement between Intertek and its Client. Intertek's responsibility and liability are limited to the terms and conditions of the agreement. Intertek assumes no liability to any party, other than to the Client in accordance with the agreement, for any loss, expense or damage occasioned by the use of this report. Only the Client is authorized to permit copying or distribution of this report and then only in its entirety. Any use of the Intertek name or one of its marks for the sale or advertisement of the tested material, product or service must first be approved in writing by Intertek. The observations and test results in this report are relevant only to the sample tested. This report by itself does not imply that the material, product, or service is or has ever been under an Intertek certification program.

© 2017 Intertek

**TEST REPORT****GENERAL INFORMATION**

|                                  |  |
|----------------------------------|--|
| <b>Grantee:</b>                  | Spin Master Toys Far East Ltd.   |
| <b>Grantee Address:</b>          | Room 1113, 11/F., Chinachem Golden Plaza,<br>77 Mody Road, Tsim Sha Tsui East,<br>Kowloon, Hong Kong.  |
| <b>Contact Person:</b>           | Tommy So   |
| <b>Tel:</b>                      | 852-2301 3822  |
| <b>Fax:</b>                      | 852-2301 1822  |
| <b>E-mail:</b>                   | tommys@spinmaster.com  |
| <b>Manufacturer:</b>             | Spin Master Toys Far East Ltd.   |
| <b>Manufacturer Address:</b>     | Room 1113, 11/F., Chinachem Golden Plaza,<br>77 Mody Road, Tsim Sha Tsui East,<br>Kowloon, Hong Kong.  |
| <b>Brand Name:</b>               | Spin Master LTD.   |
| <b>Model:</b>                    | 66803  |
| <b>Additional Model:</b>         | 58769, 6064930, 1084429, 6066098, 1085821, 58782, 6066359,<br>1086142, 6044952, 1078779, 1078778, 6044955, 1078775, 1078772,<br>6047109, 1062922, 6047110, 1062921, 6047111, 1062920, 6047112,<br>1078532, 1077830, 1062916, 6055574, 1073470, 6060323, 1078533,<br>6060517, 1078829, 6060603, 1079819, 1079016, 6062898, 1081742,<br>6059401, 1077207, 66810, 1082678, 6063605, 1060081, 1060101,<br>1060107, 1060108, 1060109, 1060110, 1062970, 1062971, 1063284,<br>1069115, 1069118, 1069117, 1078320, 1078776, 1078963, 1081220,<br>6044957, 6044950, 6044954, 6044951, 6047145, 6047146, 6047314,<br>6053017, 6053018, 6053019, 6062287 |
| <b>Type of EUT:</b>              | Transceiver  |
| <b>Description of EUT:</b>       | Ref. to P.3-4 of Test Report   |
| <b>Serial Number:</b>            | N/A  |
| <b>FCC ID:</b>                   | PQN66803RX2G42   |
| <b>Phantom No.:</b>              | 20103727/20103589/20103729/20103591/20103730/20103592/<br>20108561/20108562/20108563/20108568/20108569/20108716/<br>20109237/20109238/20109239/20128981/20128982/20128983/<br>20130533/20130539/20130541/20108561/20108563/20130538/<br>20130542/20138377/ 20140308  |
| <b>Date of Sample Submitted:</b> | May 20, 2022   |
| <b>Date of Test:</b>             | May 20, 2022 to June 30, 2022  |
| <b>Report No.:</b>               | 22050961HKG-003R1  |
| <b>Report Date:</b>              | August 18, 2022  |
| <b>Environmental Conditions:</b> | Temperature: +10 to 40°C<br>Humidity: 10 to 90%  |
| <b>Conclusion:</b>               | Test was conducted by client submitted sample. The submitted sample as received complied with the 47 CFR Part 15 Certification.  |

## TEST REPORT

### GENERAL INFORMATION

#### Description of EUT:

MJC 1to24 El Toro Loco (66803),  
MNJ RDC 1t24BTBDragonRC (58769),  
MNJ RDC 1t24BTBDragonRC (6064930),  
MNJ RDC 1t24BTBDragonRC (1084429),  
MNJ RDC 1t24BTBDragonRC (6066098),  
MNJ RDC 1t24BTBDragonRC (1085821),  
MNJ RDC RC 1 24 BJSX (58782),  
MNJ RDC RC 1 24 BJSX (6066359),  
MNJ RDC RC 1 24 BJSX (1086142),  
MJC RDC 1to24 Megalodon (6044952),  
MJC RDC 1to24 Megalodon (1078779),  
MJC 1:24th Megalodon (1078778),  
MJC RDC 1to24 GraveDigger (6044955),  
MJC RDC 1to24 GraveDigger (1078775),  
MJC 1:24th Grave Digger (1078772),  
MJC RDC 1t24 MMDalmatin (6047109),  
MJC RDC 1t24 MMDalmatin (1062922),  
MJC RDC 1to24 Megalodon (6047110),  
MJC RDC 1to24 Megalodon (1062921),  
MJC RDC 1to24 GraveDigger (6047111),  
MJC RDC 1to24 GraveDigger (1062920),  
MJC 1to24 El Toro Loco (6047112),  
MJC 1to24 El Toro Loco (1078532),  
MJC 1:24 Assortment (1077830),  
MJC 1to24 Truck (1062916),  
MJC RDC 1to24 CDU Ast (6055574),  
MJC RDC 1to24 CDU Ast (1073470),  
MJC RDC 1to24 ElToroLoco (6060323),  
MJC RDC 1to24 ElToroLoco (1078533),  
MJC 1to24 El Toro Loco (6060517),  
MJC 1to24 El Toro Loco (1078829),  
MJC 1:24th GBL AST (6060603),  
MJC 1:24th GBL AST (1079819),  
MJC 1:24th GBL AST (1079016),  
MJC RDC 1t24ScaleGraveDigr (6062898),  
MJC RDC 1t24ScaleGraveDigr (1081742),  
MJC 1to24 El Toro Loco (6059401),  
MJC 1to24 El Toro Loco (1077207),  
MJC RDC Racing Rivals INTL GML1pkSLD (66810),  
MJC RDC Racing Rivals INTL GML1pkSLD (1082678),  
MJC RDC Racing Rivals INTL GML1pkSLD (6063605),  
MJC RC 24th Scale Grave Digger M01 (1060081),  
MJC RDC 1to24 GraveDigger (1060101),  
MJC RC 24th Scale Megalodon M01 (1060107),  
MJC RDC 1to24 Megalodon (1060108),

## TEST REPORT

### GENERAL INFORMATION

#### Description of EUT:

MJC RC 24th Scale Monster Mutt Dalmatian M01 (1060109),  
MJC RDC 1to24 MstMutDIImtn (1060110),  
MJC RDC 1t24 FirIcMgalodn (1062970),  
MJC RDC 1t24 FirIcMgalodn (1062971),  
MJC RDC 1 to 24 Scale Ast (1063284),  
MJC RDC 1to24 MstMutDIImtn (1069115),  
MJC RDC 1to24 GraveDigger (1069118),  
MJC RDC 1to24 Megalodon (1069117),  
MJC RDC 1to24 Scale Ast CDU (1078320),  
MJC 1:24th Monster Mutt Dalmatian (1078776),  
MJC RDC 1to24 Scale Ast (1078963),  
MJC Racing Rivals GML TRGX (1081220),  
MJC RC 24th Scale Grave Digger M01 (6044957),  
MJC RC 24th Scale Monster Mutt Dalmatian M01 (6044950),  
MJC RC 24th Scale Megalodon (6044954),  
MJC 1:24th Monster Mutt Dalmatian (6044951),  
MJC RDC 1t24 FirIcMgalodn (6047145),  
MJC RDC 1t24 FirIcMgalodn (6047146),  
MJC RDC 1 to 24 Scale Ast (6047314),  
MJC RDC 1to24 MstMutDIImtn (6053017),  
MJC RDC 1to24 Megalodon (6053018),  
MJC RDC 1to24 GraveDigger (6053019),  
MJC Racing Rivals GML TRGX (6062287)

### AMENDMENT HISTORY

| Report No.        | Issued Date     | Content                                      |
|-------------------|-----------------|--|
| 22050961HKG-003   | July 29, 2022   | Original Report                              |
| 22050961HKG-003R1 | August 18, 2022 | Add Product Description and Additional Model |

## TEST REPORT

### SUMMARY OF TEST RESULT

| Test Specification                    | Reference      | Results  |
|---------------------------------------|----------------|----------|
| Radiated Emission                     | 15.249, 15.209 | Complied |
| Radiated Emission on the Bandedge     |                |          |
| Radiated Emission in Restricted Bands | 15.205         | Complied |

The equipment under test is found to be complying with the following standards:  
FCC Part 15, October 1, 2020 Edition

- Note:
1. The EUT uses a permanently attached antenna which, in accordance to section 15.203, is considered sufficient to comply with the pervisions of this section.
  2. Pursuant to FCC part 15 Section 15.215(c), the 20 dB bandwidth of the emission was contained within the frequency band designated (mentioned as above) which the EUT operated. The effects, if any, from frequency sweeping, frequency hopping, other modulation techniques and frequency stability over excepted variations in temperature and supply voltage were considered.

**TEST REPORT**

**TABLE OF CONTENTS**

**1.0 GENERAL DESCRIPTION..... 7**

1.1 Product Description .....7

1.2 Related Submittal(s) Grants.....7

1.3 Test Methodology .....7

1.4 Test Facility.....7

**2.0 SYSTEM TEST CONFIGURATION..... 8**

2.1 Justification .....8

2.2 EUT Exercising Software.....8

2.3 Special Accessories.....8

2.4 Measurement Uncertainty.....8

2.5 Support Equipment List and Description .....8

**3.0 EMISSION RESULTS..... 9**

3.1 Field Strength Calculation .....9

3.2 Radiated Emission Configuration Photograph.....10

3.3 Radiated Emission Data .....10

**4.0 EQUIPMENT PHOTOGRAPHS..... 15**

**5.0 PRODUCT LABELLING ..... 15**

**6.0 TECHNICAL SPECIFICATIONS ..... 15**

**7.0 INSTRUCTION MANUAL ..... 15**

**8.0 MISCELLANEOUS INFORMATION ..... 16**

8.1 Radiated Emission on the Bandedge .....16

8.2 Emissions Test Procedures.....17

8.3 Occupied Bandwidth .....19

**9.0 EQUIPMENT LIST ..... 20**

## TEST REPORT

### 1.0 GENERAL DESCRIPTION

#### 1.1 Product Description

The Equipment Under Test (EUT), is a portable 2.4GHz Transceiver (Car Unit) for a RC Car. The sample supplied operated on 22 channels, normally at 2411 - 2472MHz. The channels are shown in below table.

|      |      |      |      |      |
|------|------|------|------|------|
| 2411 | 2413 | 2420 | 2422 | 2424 |
| 2426 | 2428 | 2432 | 2435 | 2437 |
| 2439 | 2441 | 2443 | 2445 | 2451 |
| 2453 | 2455 | 2457 | 2461 | 2468 |
| 2470 | 2472 |      |      |      |

The EUT is powered by 3 x 1.5V AAA batteries. After switching on the EUT, the car will be moved forward or backward and turned left and right based on the switches pressed in the controller.

The Models: 58769, 6064930, 1084429, 6066098, 1085821, 58782, 6066359, 1086142, 6044952, 1078779, 1078778, 6044955, 1078775, 1078772, 6047109, 1062922, 6047110, 1062921, 6047111, 1062920, 6047112, 1078532, 1077830, 1062916, 6055574, 1073470, 6060323, 1078533, 6060517, 1078829, 6060603, 1079819, 1079016, 6062898, 1081742, 6059401, 1077207, 66810, 1082678, 6063605, 1060081, 1060101, 1060107, 1060108, 1060109, 1060110, 1062970, 1062971, 1063284, 1069115, 1069118, 1069117, 1078320, 1078776, 1078963, 1081220, 6044957, 6044950, 6044954, 6044951, 6047145, 6047146, 6047314, 6053017, 6053018, 6053019 and 6062287 are the same as the Model: 66803 in hardware aspect. The models are different in car body and packaging only as declared by client.

Antenna Type: Internal, Integral

For electronic filing, the brief circuit description is saved with filename: descri.pdf.

#### 1.2 Related Submittal(s) Grants

This is a single application for certification of a transceiver.

The Certification procedure of transceiver for this transceiver (with FCC ID: PQN66803TX2G42) is being processed as the same time of this application.

#### 1.3 Test Methodology

Radiated emission measurements were performed according to the procedures in ANSI C63.10 (2013). All radiated measurements were performed in an 3m Chamber. Preliminary scans were performed in the 3m Chamber only to determine worst case modes. All radiated tests were performed at an antenna to EUT distance of 3 meters, unless stated otherwise in the “**Justification Section**” of this Application.

#### 1.4 Test Facility

The 3m Chamber used to collect the radiated data is located at Workshop No. 3, G/F., World-Wide Industrial Centre, 43-47 Shan Mei Street, Fo Tan, Sha Tin, N.T., Hong Kong SAR, China. This test facility and site measurement data have been placed on file with the FCC.

## TEST REPORT

### 2.0 SYSTEM TEST CONFIGURATION

#### 2.1 Justification

The system was configured for testing in a typical fashion (as a customer would normally use it), and in the confines as outlined in ANSI C63.10 (2013).

The device was powered by DC 4.5V (3 x 1.5V AAA batteries).

For maximizing emissions, the EUT was rotated through 360°, the antenna height was varied from 1 meter to 4 meters above the ground plane, and the antenna polarization was changed. This step by step procedure for maximizing emissions led to the data reported in Exhibit 3.0.

The unit was operated standalone and placed in the center of the turntable.

The equipment under test (EUT) was configured for testing in a typical fashion (as a customer would normally use it). The EUT was mounted to a plastic stand if necessary and placed on the wooden turntable, which enabled the engineer to maximize emissions through its placement in the three orthogonal axes.

#### 2.2 EUT Exercising Software

There was no special software to exercise the device. Once the unit is powered up, it transmits the RF signal continuously.

#### 2.3 Special Accessories

There are no special accessories necessary for compliance of this product.

#### 2.4 Measurement Uncertainty

Decision Rule for compliance: For FCC/IC standard, the measured value must be within the limits of applicable standard without accounting for the measurement uncertainty. For EN/IEC/HKTA/HKTC standard, conformity rules will be used as per standard directly excepted EN/IEC 61000-3-2, EN/IEC 61000-3-3, HKTA1004, HKCA1008, HKTA1019, HKTA1020, HKTA1041 and HKTA1044. For these excepted or not mentioned standards, Cl 4.2.2 of ILAC-G8:09/2019 decision rules will be reference and guard band will be equal to our measurement uncertainty with 95% confidence level (k=2). In case, the measured value is within guard band region, undetermined decision will be used.

#### 2.5 Support Equipment List and Description

Not Applicable.



## TEST REPORT

### 3.0 EMISSION RESULTS

Data is included of the worst case configuration (the configuration which resulted in the highest emission levels). A sample calculation, configuration photographs and data tables of the emissions are included.

#### 3.1 Field Strength Calculation

The field strength is calculated by adding the Antenna Factor and Cable Factor, and subtracting the Amplifier Gain (if any), Average Factor (optional) from the measured reading.

The basic equation with a sample calculation is as follows:

$$FS = RA + AF + CF - AG - AV$$

where

- FS = Field Strength in dB $\mu$ V/m
- RA = Receiver Amplitude (including preamplifier) in dB $\mu$ V
- AF = Antenna Factor in dB
- CF = Cable Attenuation Factor in dB
- AG = Amplifier Gain in dB
- AV = Average Factor in dB

In the following table(s), the reading shown on the data table reflects the preamplifier gain.

An example for the calculations in the following table is as follows:

$$FS = RR + LF$$

where

- FS = Field Strength in dB $\mu$ V/m
- RR = RA - AG - AV in dB $\mu$ V
- LF = CF + AF in dB

Assume a receiver reading of 52.0 dB $\mu$ V is obtained. The antenna factor of 7.4 dB and cable factor of 1.6 dB are added. The amplifier gain of 29.0 dB and average factor of 5.0 dB are subtracted, giving a field strength of 27.0 dB $\mu$ V/m. This value in dB $\mu$ V/m was converted to its corresponding level in  $\mu$ V/m.

|                               |                      |
|-------------------------------|----------------------|
| RA = 52.0 dB $\mu$ V/m        |                      |
| AF = 7.4 dB                   | RR = 18.0 dB $\mu$ V |
| CF = 1.6 dB                   | LF = 9.0 dB          |
| AG = 29.0 dB                  |                      |
| AV = 5.0 dB                   |                      |
| FS = RR + LF                  |                      |
| FS = 18 + 9 = 27 dB $\mu$ V/m |                      |

Level in  $\mu$ V/m = Common Antilogarithm [(27 dB $\mu$ V/m)/20] = 22.4  $\mu$ V/m

## TEST REPORT

### 3.2 Radiated Emission Configuration Photograph

The worst case in radiated emission was found at 2483.5 MHz

For electronic filing, the worst case radiated emission configuration photographs are saved with filename: radiated photos.pdf.

### 3.3 Radiated Emission Data

The data on the following page lists the significant emission frequencies, the limit and the margin of compliance. Numbers with a minus sign are below the limit.

Judgment: Passed by 7.5 dB

**TEST REPORT**

**RADIATED EMISSIONS**

Model: 66803  
Date of Test: June 30, 2022  
Worst-Case Operating Mode: Transmitting

**Table 1  
Pursuant to FCC Part 15 Section 15.249 Requirement**

**Lowest Channel**

| Polarization | Frequency (MHz) | Reading (dBµV) | Pre-Amp Gain (dB) | Antenna Factor (dB) | Net at 3m - Average (dBµV/m) | Average Limit at 3m (dBµV/m) | Margin (dB) |
|--------------|-----------------|----------------|-------------------|---------------------|------------------------------|------------------------------|-------------|
| H            | 2411.000        | 79.5           | 33                | 29.4                | 75.9                         | 94.0                         | -18.1       |
| H            | 2400.000        | 40.8           | 33                | 29.4                | 37.2                         | 54.0                         | -16.8       |
| V            | 4822.000        | 27.5           | 33                | 34.9                | 29.4                         | 54.0                         | -24.6       |
| H            | 7233.000        | 22.1           | 33                | 37.9                | 27.0                         | 54.0                         | -27.0       |
| H            | 9644.000        | 27.9           | 33                | 40.4                | 35.3                         | 54.0                         | -18.7       |
| V            | 12055.000       | 25.5           | 33                | 40.5                | 33.0                         | 54.0                         | -21.0       |
| H            | 14466.000       | 29.7           | 33                | 40.0                | 36.7                         | 54.0                         | -17.3       |

| Polarization | Frequency (MHz) | Reading (dBµV) | Pre-Amp Gain (dB) | Antenna Factor (dB) | Net at 3m - Peak (dBµV/m) | Peak Limit at 3m (dBµV/m) | Margin (dB) |
|--------------|-----------------|----------------|-------------------|---------------------|---------------------------|---------------------------|-------------|
| H            | 2411.000        | 103.4          | 33                | 29.4                | 99.8                      | 114.0                     | -14.2       |
| H            | 2400.000        | 68.3           | 33                | 29.4                | 64.7                      | 74.0                      | -9.3        |
| V            | 4822.000        | 46.5           | 33                | 34.9                | 48.4                      | 74.0                      | -25.6       |
| H            | 7233.000        | 38.9           | 33                | 37.9                | 43.8                      | 74.0                      | -30.2       |
| H            | 9644.000        | 41.1           | 33                | 40.4                | 48.5                      | 74.0                      | -25.5       |
| V            | 12055.000       | 39.8           | 33                | 40.5                | 47.3                      | 74.0                      | -26.7       |
| H            | 14466.000       | 42.7           | 33                | 40.0                | 49.7                      | 74.0                      | -24.3       |

- NOTES: 1. Peak Detector Data unless otherwise stated.  
 2. Average detector is applied according to ANSI C63.10.  
 3. All measurements were made at 3 meters.  
 4. Negative value in the margin column shows emission below limit.  
 5. Horn antenna is used for the emission over 1000MHz.  
 6. Emissions within the restricted band meets the requirement of FCC Part 15 Section 15.205.  
 7. Measurement Uncertainty is ±5.3dB at a level of confidence of 95%.

**TEST REPORT**

**RADIATED EMISSIONS**

Model: 66803  
Date of Test: June 30, 2022  
Worst-Case Operating Mode: Transmitting

Table 2  
**Pursuant to FCC Part 15 Section 15.249 Requirement**

Middle Channel

| Polarization | Frequency (MHz) | Reading (dBµV) | Pre-Amp Gain (dB) | Antenna Factor (dB) | Net at 3m - Average (dBµV/m) | Average Limit at 3m (dBµV/m) | Margin (dB) |
|--------------|-----------------|----------------|-------------------|---------------------|------------------------------|------------------------------|-------------|
| V            | 2441.000        | 81.9           | 33                | 29.4                | 78.3                         | 94.0                         | -15.7       |
| V            | 4882.000        | 30.9           | 33                | 34.9                | 32.8                         | 54.0                         | -21.2       |
| H            | 7323.000        | 28.8           | 33                | 37.9                | 33.7                         | 54.0                         | -20.3       |
| H            | 9764.000        | 27.7           | 33                | 40.4                | 35.1                         | 54.0                         | -18.9       |
| H            | 12205.000       | 26.1           | 33                | 40.5                | 33.6                         | 54.0                         | -20.4       |
| V            | 14646.000       | 32.4           | 33                | 38.4                | 37.8                         | 54.0                         | -16.2       |

| Polarization | Frequency (MHz) | Reading (dBµV) | Pre-Amp Gain (dB) | Antenna Factor (dB) | Net at 3m - Peak (dBµV/m) | Peak Limit at 3m (dBµV/m) | Margin (dB) |
|--------------|-----------------|----------------|-------------------|---------------------|---------------------------|---------------------------|-------------|
| V            | 2441.000        | 106.0          | 33                | 29.4                | 102.4                     | 114.0                     | -11.6       |
| V            | 4882.000        | 52.4           | 33                | 34.9                | 54.3                      | 74.0                      | -19.7       |
| H            | 7323.000        | 45.2           | 33                | 37.9                | 50.1                      | 74.0                      | -23.9       |
| H            | 9764.000        | 40.8           | 33                | 40.4                | 48.2                      | 74.0                      | -25.8       |
| H            | 12205.000       | 40.0           | 33                | 40.5                | 47.5                      | 74.0                      | -26.5       |
| V            | 14646.000       | 45.5           | 33                | 38.4                | 50.9                      | 74.0                      | -23.1       |

- NOTES: 1. Peak Detector Data unless otherwise stated.  
2. Average detector is applied according to ANSI C63.10.  
3. All measurements were made at 3 meters.  
4. Negative value in the margin column shows emission below limit.  
5. Horn antenna is used for the emission over 1000MHz.  
6. Emissions within the restricted band meets the requirement of FCC Part 15 Section 15.205.  
7. Measurement Uncertainty is ±5.3dB at a level of confidence of 95%.

**TEST REPORT**

**RADIATED EMISSIONS**

Model: 66803  
Date of Test: June 30, 2022  
Worst-Case Operating Mode: Transmitting

Table 3  
**Pursuant to FCC Part 15 Section 15.249 Requirement**

Highest Channel

| Polarization | Frequency (MHz) | Reading (dBµV) | Pre-Amp Gain (dB) | Antenna Factor (dB) | Net at 3m - Average (dBµV/m) | Average Limit at 3m (dBµV/m) | Margin (dB) |
|--------------|-----------------|----------------|-------------------|---------------------|------------------------------|------------------------------|-------------|
| H            | 2472.000        | 79.8           | 33                | 29.4                | 76.2                         | 94.0                         | -17.8       |
| H            | 2483.500        | 41.1           | 33                | 29.4                | 37.5                         | 54.0                         | -16.5       |
| V            | 4944.000        | 28.3           | 33                | 34.9                | 30.2                         | 54.0                         | -23.8       |
| H            | 7416.000        | 21.0           | 33                | 37.9                | 25.9                         | 54.0                         | -28.1       |
| V            | 9888.000        | 26.8           | 33                | 40.4                | 34.2                         | 54.0                         | -19.8       |
| V            | 12360.000       | 27.1           | 33                | 40.5                | 34.6                         | 54.0                         | -19.4       |
| V            | 14832.000       | 32.8           | 33                | 38.4                | 38.2                         | 54.0                         | -15.8       |

| Polarization | Frequency (MHz) | Reading (dBµV) | Pre-Amp Gain (dB) | Antenna Factor (dB) | Net at 3m - Peak (dBµV/m) | Peak Limit at 3m (dBµV/m) | Margin (dB) |
|--------------|-----------------|----------------|-------------------|---------------------|---------------------------|---------------------------|-------------|
| H            | 2472.000        | 103.7          | 33                | 29.4                | 100.1                     | 114.0                     | -13.9       |
| H            | 2483.500        | 70.1           | 33                | 29.4                | 66.5                      | 74.0                      | -7.5        |
| V            | 4944.000        | 50.5           | 33                | 34.9                | 52.4                      | 74.0                      | -21.6       |
| H            | 7416.000        | 35.8           | 33                | 37.9                | 40.7                      | 74.0                      | -33.3       |
| V            | 9888.000        | 40.2           | 33                | 40.4                | 47.6                      | 74.0                      | -26.4       |
| V            | 12360.000       | 40.6           | 33                | 40.5                | 48.1                      | 74.0                      | -25.9       |
| V            | 14832.000       | 45.7           | 33                | 38.4                | 51.1                      | 74.0                      | -22.9       |

- NOTES: 1. Peak Detector Data unless otherwise stated.  
2. Average detector is applied according to ANSI C63.10.  
3. All measurements were made at 3 meters.  
4. Negative value in the margin column shows emission below limit.  
5. Horn antenna is used for the emission over 1000MHz.  
6. Emissions within the restricted band meets the requirement of FCC Part 15 Section 15.205.  
7. Measurement Uncertainty is ±5.3dB at a level of confidence of 95%.

**TEST REPORT**

**RADIATED EMISSIONS**

Model: 66803  
Date of Test: June 30, 2022  
Worst-Case Operating Mode: Transmitting

Table 4  
**Pursuant to FCC Part 15 Section 15.209 Requirement**

| Polarization | Frequency (MHz) | Reading (dBµV) | Pre-amp (dB) | Antenna Factor (dB) | Net at 3m (dBµV/m) | Limit at 3m (dBµV/m) | Margin (dB) |
|--------------|-----------------|----------------|--------------|---------------------|--------------------|----------------------|-------------|
| V            | 30.000          | 24.3           | 16           | 10.0                | 18.3               | 40.0                 | -21.7       |
| V            | 131.123         | 19.6           | 16           | 14.0                | 17.6               | 43.5                 | -25.9       |
| H            | 347.675         | 11.5           | 16           | 24.0                | 19.5               | 46.0                 | -26.5       |
| H            | 495.843         | 13.7           | 16           | 26.0                | 23.7               | 46.0                 | -22.4       |
| H            | 655.650         | 16.8           | 16           | 29.0                | 29.8               | 46.0                 | -16.2       |
| V            | 952.106         | 16.0           | 16           | 33.0                | 33.0               | 46.0                 | -13.0       |

- NOTES: 1. Peak Detector Data unless otherwise stated.  
2. All measurements were made at 3 meters.  
3. Negative value in the margin column shows emission below limit.  
4. Horn antenna is used for the emission over 1000MHz.  
5. Emissions within the restricted band meets the requirement of FCC Part 15 Section 15.205.  
6. Measurement Uncertainty is ±5.3dB at a level of confidence of 95%.

## TEST REPORT

### 4.0 EQUIPMENT PHOTOGRAPHS

For electronic filing, the photographs are saved with filename: external photos.pdf and internal photos.pdf.

### 5.0 PRODUCT LABELLING

For electronics filing, the FCC ID label artwork and the label location are saved with filename: label.pdf.

### 6.0 TECHNICAL SPECIFICATIONS

For electronic filing, the block diagram and schematic of the tested EUT are saved with filename: block.pdf and circuit.pdf respectively.

### 7.0 INSTRUCTION MANUAL

For electronic filing, a preliminary copy of the Instruction Manual is saved with filename: manual.pdf.

This manual will be provided to the end-user with each unit sold/leased in the United States.

**TEST REPORT**

**8.0 MISCELLANEOUS INFORMATION**

The miscellaneous information includes details of the test procedure and measured bandwidth.

**8.1 Radiated Emission on the Bandedge**

The emission of bandedge data were shown on the above radiated data table of 1 & 3 respectively.

Emissions radiated outside of the specified frequency bands, except harmonics, are attenuated by 50dB below the level of the fundamental or to the general radiated emissions limits in Section 15.209, whichever is the lesser attenuation, which meet the requirement of Part 15.249(d).

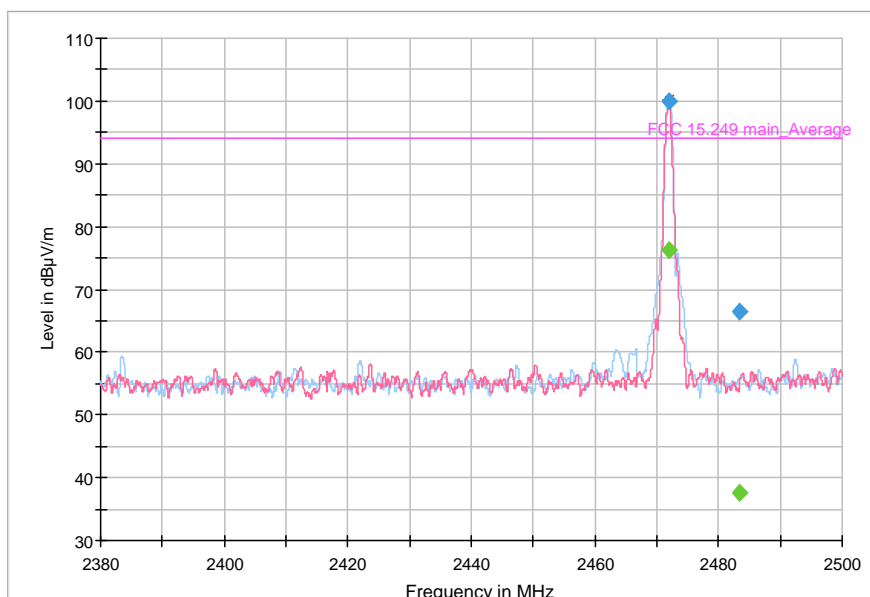
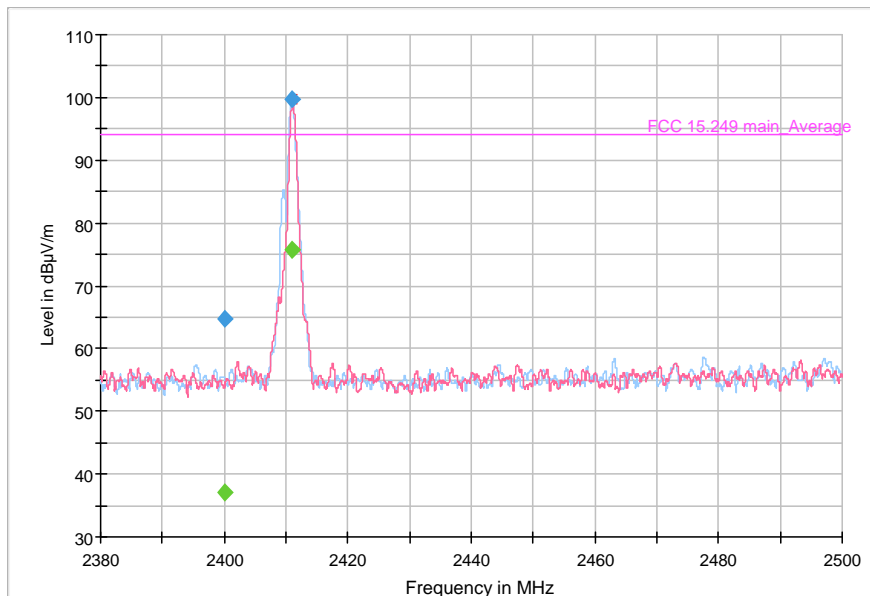



## TEST REPORT

### 8.2 Emissions Test Procedures

The following is a description of the test procedure used by Intertek Testing Services Hong Kong Ltd. in the measurements of transmitter operating under the Part 15, Subpart C rules.

The transmitting equipment under test (EUT) is placed on a wooden turntable which is four feet in diameter and approximately 0.8m in height above the ground plane for emission measurement at or below 1GHz and 1.5m in height above the ground plane for emission measurement above 1GHz. During the radiated emissions test, the turntable is rotated and any cables leaving the EUT are manipulated to find the configuration resulting in maximum emissions. The EUT is adjusted through all three orthogonal axis to obtain maximum emission levels. The antenna height and polarization are also varied during the testing to search for maximum signal levels. The height of the antenna is varied from one to four meters.

Detector function for radiated emissions is in peak mode. Average readings, when required, are taken by measuring the duty cycle of the equipment under test and subtracting the corresponding amount in dB from the measured peak readings. A detailed description for the calculation of the average factor can be found in Exhibit 8.3.

The frequency range scanned is from the lowest radio frequency signal generated in the device which is greater than 9 kHz to the tenth harmonic of the highest fundamental frequency or 40 GHz, whichever is lower.

The EUT is warmed up for 15 minutes prior to the test.

AC power to the unit is varied from 85% to 115% nominal and variation in the fundamental emission field strength is recorded. If battery powered, a new, fully charged battery is used.

Conducted measurements were made as described in ANSI C63.10 (2013).

The IF bandwidth used for measurement of radiated signal strength was 100 kHz or greater when frequency is below 1000 MHz. Where pulsed transmissions of short enough pulse duration warrant, a greater bandwidth is selected according to the recommendations of Hewlett Packard Application Note 150-2. A discussion of whether pulse desensitivity is applicable to this unit is included in this report (See Exhibit 8.1). Above 1000 MHz, a resolution bandwidth of 10 MHz is used.

Transmitter measurements are normally conducted at a measurement distance of three meters. However, to assure low enough noise floor in the forbidden bands and above 1 GHz, signals are acquired at a distance of one meter or less. All measurements are extrapolated to three meters using inverse scaling, unless otherwise reported. Measurements taken at a closer distance are so marked.

**TEST REPORT**

8.2.1 Radiated Emission Test Setup

The figure below shows the test setup, which is utilized to make these measurements.

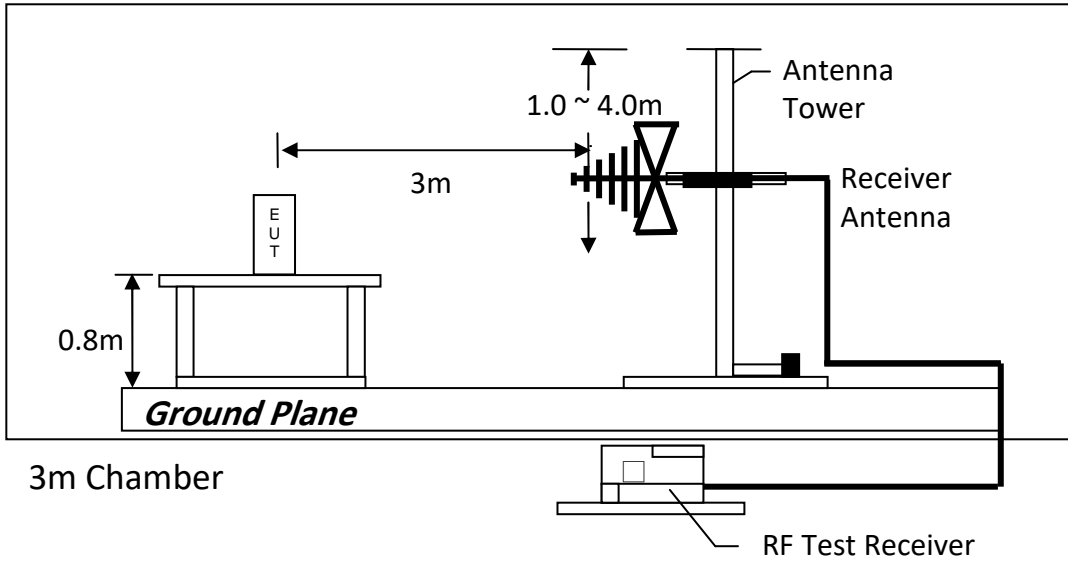

Test setup of radiated emissions up to 1GHz

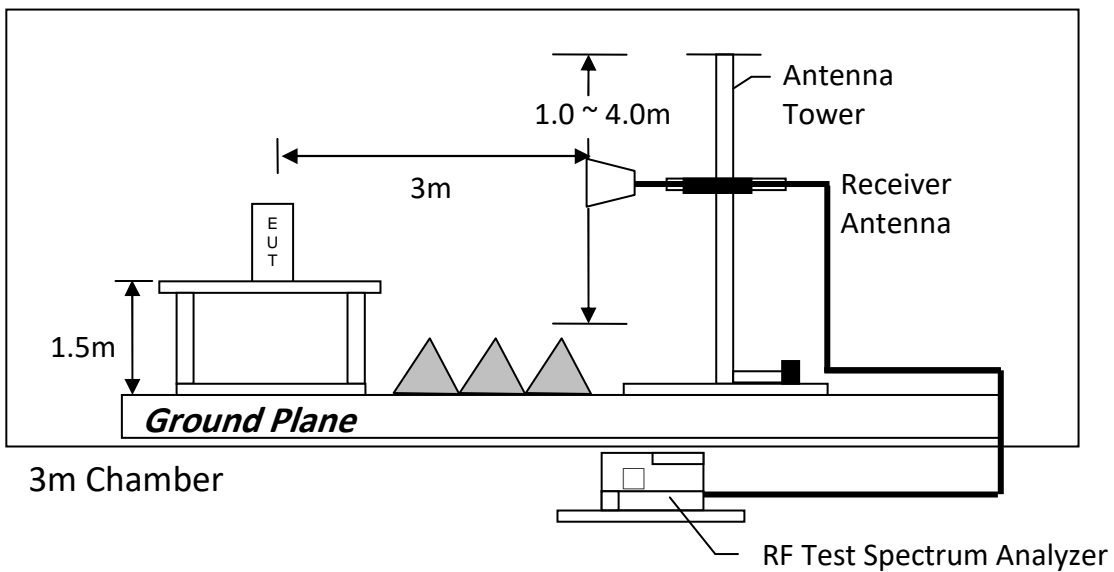

Test setup of radiated emissions above 1GHz

**TEST REPORT**

8.3 Occupied Bandwidth

Occupied Bandwidth Results:

|                      | Occupied Bandwidth (kHz) |
|----------------------|--------------------------|
| Low Channel: 2411    | 3880                     |
| Middle Channel: 2441 | 2240                     |
| High Channel: 2472   | 2040                     |

The worst case is shown as below

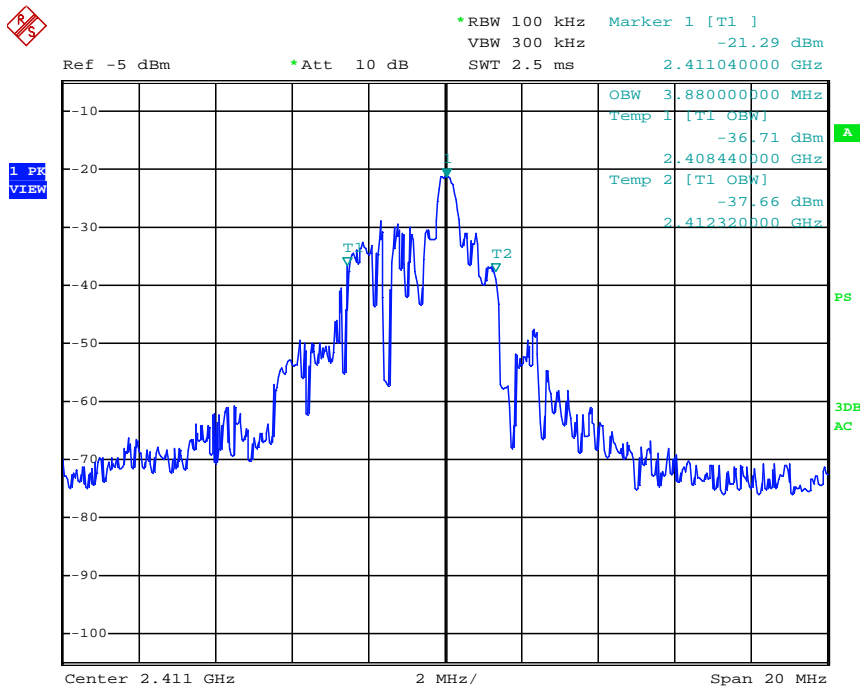

## TEST REPORT

### 9.0 EQUIPMENT LIST

#### 1) Radiated Emissions Test

| Equipment            | Signal and Spectrum Analyzer (10Hz to 40GHz) | Biconical Antenna (20MHz to 200MHz) | EMI Test Receiver 7GHz |
|----------------------|--|-------------------------------------|------------------------|
| Registration No.     | EW-3016                                      | EW-3061                             | EW-3481                |
| Manufacturer         | ROHDESCHWARZ                                 | EMCO                                | ROHDESCHWARZ           |
| Model No.            | FSV40  | 3142E                               | ESR7                   |
| Calibration Date     | October 29, 2021                             | February 02, 2021                   | December 21, 2021      |
| Calibration Due Date | October 29, 2022                             | August 02, 2022                     | December 21, 2022      |

| Equipment            | Log Periodic Antenna | Double Ridged Guide Antenna | Active Loop H-field (9kHz to 30MHz) |
|----------------------|----------------------|-----------------------------|-------------------------------------|
| Registration No.     | EW-3243              | EW-1133                     | EW-3302                             |
| Manufacturer         | EMCO                 | EMCO                        | EMCO                                |
| Model No.            | 3148B                | 3115                        | 6502                                |
| Calibration Date     | June 03, 2021        | May 26, 2021                | December 13, 2021                   |
| Calibration Due Date | December 30, 2022    | November 26, 2022           | June 13, 2023                       |

| Equipment            | RF Pre-amplifier (9kHz to 6000MHz) | 2.4GHz Notch Filter | 14m Double Shield RF Cable (20MHz to 6GHz) |
|----------------------|------------------------------------|---------------------|--|
| Registration No.     | EW-3006b                           | EW-3435             | EW-2074                                    |
| Manufacturer         | SCHWARZBECK                        | MICROWAVE           | RADIALL                                    |
| Model No.            | BBV9718                            | N0324413            | N(m)-RG142-BNC(m)<br>L=14M                 |
| Calibration Date     | February 15, 2022                  | November 16, 2019   | November 14, 2019                          |
| Calibration Due Date | February 15, 2023                  | September 16, 2022  | August 14, 2022                            |

| Equipment            | Pyramidal Horn Antenna |
|----------------------|------------------------|
| Registration No.     | EW-0905                |
| Manufacturer         | EMCO                   |
| Model No.            | 3160-09                |
| Calibration Date     | July 20, 2021          |
| Calibration Due Date | January 20, 2023       |

**TEST REPORT**

## 2) Bandedge Measurement

| <b>Equipment</b>     | <b>Spectrum Analyzer</b> |
|----------------------|--------------------------|
| Registration No.     | EW-2466                  |
| Manufacturer         | ROHDESCHWARZ             |
| Model No.            | FSP30                    |
| Calibration Date     | November 18, 2019        |
| Calibration Due Date | August 18, 2022          |

## 3) OBW Measurement

| <b>Equipment</b>     | <b>Spectrum Analyzer</b> |
|----------------------|--------------------------|
| Registration No.     | EW-2466                  |
| Manufacturer         | ROHDESCHWARZ             |
| Model No.            | FSP30                    |
| Calibration Date     | November 18, 2019        |
| Calibration Due Date | August 18, 2022          |

## 4) Control Software for Radiated Emission

| <b>Software Information</b> |              |
|-----------------------------|--------------|
| Software Name               | EMC32        |
| Manufacturer                | ROHDESCHWARZ |
| Software version            | 10.50.40     |

**END OF TEST REPORT**