

Technical Description

The Equipment Under Test (EUT) is a portable 2.4GHz Transceiver (Plane) operating at the frequency range of 2411-2472MHz with the following frequency table.

2411MHz	2413MHz	2420MHz	2422MHz	2424MHz	2426MHz	2428MHz	2435MHz	2437MHz	2439MHz
2441MHz	2443MHz	2445MHz	2451MHz	2453MHz	2455MHz	2457MHz	2461MHz	2468MHz	2470MHz
2472MHz									

The EUT is powered by 1*3.7V rechargeable battery. By activating the slide bar, the controller will be able to control the speed of the EUT.

The brief circuit description is listed as below:

- 1) U1 acts as Voltage Regulator (CE1239_3.0V).
- 2) U2 acts as MCU and 2.4GHz RF Module Circuit (RF HF2402 - SOP16).
- 3) Y1 is 16MHz crystal oscillator providing clock for U2.
- 4) U3 acts as charging circuit (HK4054).

Antenna Type: Internal antenna

Antenna Gain: 0dBi

Nominal rated field strength: 87.6dB μ V/m at 3m

Maximum allowed field strength of production tolerance: +/- 3dB

HF2404 产品说明书

HF2404 Product Manual

AD 型 2.4G 高速无线收发单片机

AD Type 2.4G High-speed wireless transceiver Microcontroller

概述 (General description)

HF2404 是一个带 12 位 ADC, 以 OTP 为程序存储基础, 带 2.4G 高速无线收发芯片的单片机。无线收发单元工作在 2.400--2.483GHz 世界通用 ISM 频段, 它集成射频收发通路、频率发生器、晶体振荡器、调制解调器等功能模块, 并且支持一对多组网和带 ACK 的通信模式。发射输出功率、工作频道以及通信数据率均可配置。它采用 GFSK 通信方式, 支持自动应答及自动重传, 自带扰码和 CRC 校验功能。

单片机运用 RISC 的架构基础使大部分的指令执行时间都是一个指令周期, 只有少部分间接地址访问的指令是需要两个指令周期。在 HF2404 内部有 1.5Kx14 bit OTP 程序存储器以及 88 Bytes 数据存储器, 芯片内部还设置有多通道的 12 位分辨率 A/D 转换器, 其中 1 通道为内置的 Band-gap 参考电压生成器, 它可以提供 1.2V 电压供测量; 另外, HF2404 提供 3 组硬件计数器 (Timer), 一个为 16 位计数器, 另外两个为 8 位计数器并且可产生 PWM 波形。

The HF2404 is a 12 bit ADC and a OTP as the program storage base, with 2.4G high-speed wireless transceiver chip microcontroller. Wireless transceiver unit work in 2.400-2.483GHz world universal ISM band, it integrates functional blocks such as RF transceiver channels, frequency generators, crystal oscillators, modems and so on, and supports one-to-many networking and communication modes with ACKs. The transmit output power, operating channel and communication data rate can be configured. It uses GFSK communication mode, supports automatic response and automatic retransmission, self-scrambling and CRC checksum function.

The microcontroller use of RISC architecture to make most of the instruction execution time is a command cycle, only partial indirect address access instructions require two instruction cycles. In the HF2404 there are 1.5Kx14 bit OTP program memory and 88 Bytes data memory, the chip is also equipped with multi-channel 12-bit resolution A / D converter, which 1 channel for the built-in Band-gap reference voltage generator, it can provide 1.2V voltage for measurement; In addition, HF2404 provides three sets of hardware counters (Timer), One is a 16 bit counter, the other two are 8 bit counters and can generate PWM waveform.

主要特性 (Features)

1、单片机 (Microcontroller)

- ◆ 时钟源: 内部高频 RC 振荡器 (IHRC)、内部低频 RC 振荡器 (ILRC)

Clock mode: internal high-frequency RC oscillator (IHRC), internal low-frequency RC oscillator (ILRC)

- ◆ 内置 Band-gap 硬件模块输出 1.20V 参考电压
Built-in Band-gap hardware module output 1.2V reference voltage
 - ◆ 内置一个硬件 16 位计数器
Built-in a hardware 16-bit timer
 - ◆ 内置两个硬件 8 位计数器并可提供 PWM 模式输出
Built-in two hardware 8-bit counter and can provide PWM mode output
 - ◆ 内置一个多通道 12 位分辨率 A/D 转换器
Built-in a multi-channel 12-bit resolution A / D converter
 - ◆ 提供 ADC 参考高电压: 外部输入, 内部 VDD, Band-gap 1.20V, 4V, 3V, 2V
provide ADC reference high voltage: external input, internal VDD, Band-gap 1.20V, 4V, 3V, 2V
 - ◆ 提供单周期 (1T) 8x8 硬件乘法器
Provide single cycle (1T) 8x8 hardware multiplier
 - ◆ 提供快速唤醒模式
Support fast wake-up mode
 - ◆ 8 段 LVR 设定~ 4.1V, 3.6V, 3.1V, 2.8V, 2.5V, 2.2V, 2.0V, 1.8V
Eight levels of LVR set : 4.1V, 3.6V, 3.1V, 2.8V, 2.5V, 2.2V, 2.0V, 1.8V
 - ◆ 可选择的外部中断引脚
Optional external interrupt pin
 - ◆ 每一 IO 引脚都可以单独设置系统唤醒功能
Every IO pin can be configured to enable wake-up function
 - ◆ 单片机工作频率 ~ 4MHz@VDD \geq 2.5V; ~ 2MHz@VDD \geq 2.2V;
Operating frequency range: 4MHz@VDD \geq 2.5V; ~ 2MHz@VDD \geq 2.2V;
 - ◆ 1.5K OTP 程序存储器
1.5K OTP program memory
 - ◆ 88 Bytes 数据存储器
88 Bytes data memory
 - ◆ 提供 86 条指令
provide 86 instructions
 - ◆ 大部份指令都是单周期 (1T) 指令
Most instructions are 1T execution cycle
 - ◆ 弹性化的堆栈深度, 可程序设定
Programmable stack pointer and adjustable stack level
 - ◆ 提供数据与指令的直接、间接寻址模式
Provide direct and indirect addressing modes for data and instructions
 - ◆ 所有的数据存储器都可当数据指针 (index pointer)
All data memories are available for use as an index pointer
 - ◆ 独立的 IO 地址以及存储地址, 方便程序开发
Separated IO space and memory space, convenient program development
- 2、无线通信单元 (Wireless communication unit)
- ◆ 工作在 2400—2483MHz 世界通用 ISM 频段
Work in 2400-2483MHz world universal ISM band
 - ◆ 自动处理数据包

Automatically process packets

- ◆ 空中数据率可编程 250Kbps/1Mbps

The air data rate can be programmed 250Kbps / 1Mbps

- ◆ 无线芯片输出功率可编程，调节范围广：-5dBm--13dBm

Wireless chip output power can be programmed, wide adjustment range:
-5dBm - 13dBm

- ◆ 无线芯片 250K / 1M 模式的灵敏度为 -91 / -87dBm

The sensitivity of the wireless chip 250K / 1M mode is -91 / -87dBm

- ◆ 抗干扰性好，接收滤波器的邻道抑制度高，接收机选择性好

Good anti-interference, the adjacent channel rejection of the receive filter is high, the selectivity of the receiver is good.

- ◆ 功耗低，性能优异，外围器件少

Low power consumption, excellent performance, few peripheral devices

3、工作条件 (working conditions)

- ◆ 工作电压：2.2V ~3.3V

Operating voltage: 2.2V ~ 3.3V

- ◆ 工作温度：-20°C ~ 70°C

Operating temperature: -20°C ~ 70°C

- ◆ 储藏温度：-40°C ~ 125°C

Storage temperature: -40°C ~ 125°C

- ◆ 节点温度：150°C

Node temperature: 150°C

- ◆ 请勿使用于 AC 阻容降压供电，强电源纹波，或高 EFT 要求之应用

Do not use for AC RC capacitive power supply, strong power ripple, or high EFT requirements

封装信息 (Package information)

HF2404-S16: SOP16 (width 150mil)

RoHS (Green)

应用方案 (Application solution)

无线鼠标键盘、电视和机顶盒遥控器、无线游戏手柄、有源无线标签、智能家居及安防系统、遥控玩具

Wireless mouse and keyboard, TV and set-top box remote control, Wireless game handle, active wireless tags, intelligent home and security systems, remote control toys

版本 (Version)	修订时间 (Revision time)	说明 (Description)	相关文档 (Related Documents)
V1.0	2016.03	初版修订 First revised edition	《 01_XN297L a range of product manual_v4p7》 《 PMS131 datasheet V005 _CN》

目录(catalog)

1 系统结构方框图(System Block Diagram).....	5
2 引脚定义和说明(Pin definition and description).....	5
2.1 引脚定义(Pin definition).....	5
2.2 引脚说明(Pin Description).....	6
2.3 芯片控制连接(Chip control connection).....	11
3 应用原理图(Typical Application Schematic).....	11
3.1 减少外围器件(Reduce peripheral devices).....	11
3.2 通过安规认证(Through security certification).....	12
4 封装尺寸(Package size).....	12
5 联系方式(Contact information).....	13

1 系统结构方框图 (System Block Diagram)

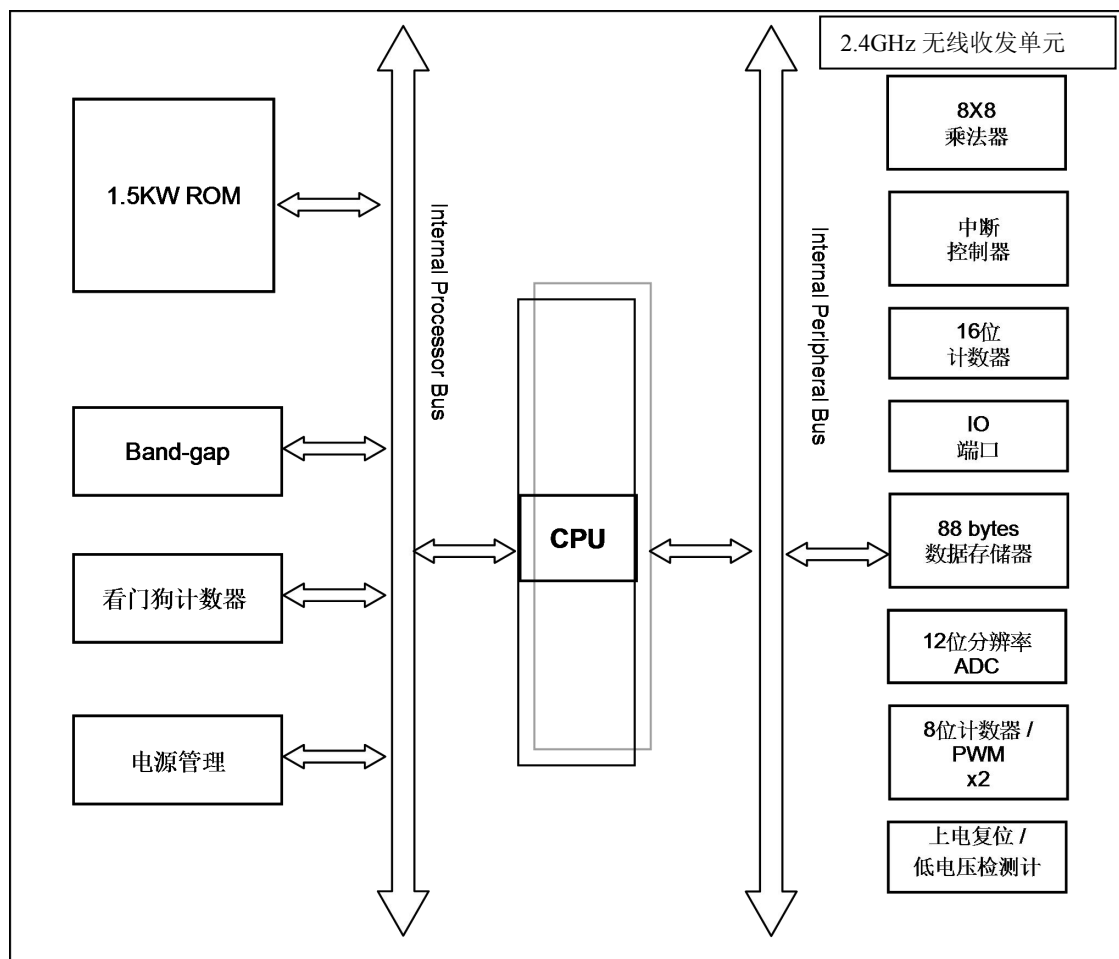

Figure1 HF2404 Chip System Block Diagram

2 引脚定义和说明 (Pin definition and description)

2.1 引脚定义 (Pin definition)

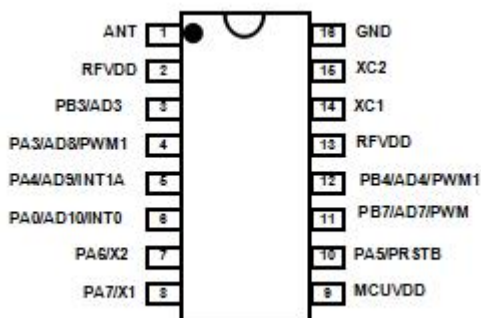

Figure2.1 HF2404 Chip Pin function diagram

2.2 引脚说明 (Pin Description)

烧录管脚(Burn pin) : PIN 4 / PIN5 / PIN7 / PIN9 / PIN10 / PIN16

表2.1 引脚功能说明 (Table 2.1 description of pin function)

NO	引脚名称 Pin Name	引脚&缓冲器 类型 Pin & buffer type	功能描述 Functional description
1	ANT	AIO	天线端口，可以用 PCB 微带天线也可以用单极子天线 Antenna port, you can use the PCB microstrip antenna or monopole antenna
2	RFVDD	P	无线芯片电源 Wireless chip power supply
3	PB3 / AD3 /	IO ST / CMOS / Analog	<p>此引脚可用作：</p> <ol style="list-style-type: none"> Port B 位 3，这个引脚可编程设定为数字输入/输出，弱上拉电阻。 ADC 模拟输入通道 3 <p>当此引脚设定为模拟输入时，请用寄存器 <i>pbdir</i> 位 3 关闭（"0"）此引脚的数字输入以减少漏电流。当此引脚设定禁用数字输入，在掉电模式的唤醒功能将同时被禁用。</p> <p>This pin can be used as:</p> <ol style="list-style-type: none"> Port B bit three, this pin can be programmed to set the digital input / output, weak pull-up resistor. ADC analog input channel three <p>When this pin is set to analog input, please use the register <i>pbdir</i> bit three to turn off ("0") the digital input of this pin to reduce the leakage current. When this pin is set to disable the digital input, the wake-up function in power-down mode will be disabled at the same time.</p>
4	PA3 / AD8 / PWM1	IO ST / CMOS / Analog	<p>此引脚可用作：</p> <ol style="list-style-type: none"> Port A 位 3，这个引脚可编程设定为数字输入/输出，弱上拉电阻。 ADC 模拟输入通道 8 Timer2 的 PWM 输出 <p>当此引脚设定为模拟输入时，请用寄存器 <i>padier</i> 位 3 关闭（"0"）此引脚的数字输入以减少漏电流。当此引脚设定禁用数字输入，在掉电模式的唤醒功能将同时被禁用。</p> <p>This pin can be used as:</p> <ol style="list-style-type: none"> Port A bit three, this pin can be programmed to set the digital input / output, weak pull-up resistor. ADC analog input channel eight Timer two PWM output <p>When this pin is set to analog input, please use the register <i>pbdir</i> bit three to turn off ("0") the digital input of this pin to reduce the leakage current. When this pin is set to disable the digital input, the wake-up function in power-down mode will be disabled at the same time.</p>

NO	引脚名称 Pin Name	引脚&缓冲器 类型 Pin & buffer type	功能描述 Functional description
5	PA4 / AD9 / INT1A	IO ST / CMOS / Analog	<p>此引脚可用作：</p> <ol style="list-style-type: none"> 1. Port A 位 4，这个引脚可编程设定为数字输入，弱上拉电阻。 2. ADC 模拟输入通道 9。 3. 外部中断服务。外部中断可发生在上升沿和下降沿 <p>当此引脚设定为模拟输入时，请用寄存器 <i>pbdier</i> 位 4 关闭（"0"）此引脚的数字输入以减少漏电流。当此引脚设定禁用数字输入，在掉电模式的唤醒功能将同时被禁用。</p> <p>This pin can be used as:</p> <ol style="list-style-type: none"> 1. Port A bit four, this pin can be programmed to set the digital input, weak pull-up resistor. 2. ADC analog input channel nine 3. External interrupt service. External interrupts can occur on rising and falling edges <p>When this pin is set to analog input, please use the register <i>pbdier</i> bit four to turn off ("0") the digital input of this pin to reduce the leakage current. When this pin is set to disable the digital input, the wake-up function in power-down mode will be disabled at the same time.</p>
6	PA0 / AD10 / INT0	IO ST / CMOS / Analog	<p>此引脚可用作：</p> <ol style="list-style-type: none"> 1. Port A 位 0，这个引脚可编程设定为数字输入/输出，弱上拉电阻。 2. ADC 模拟输入通道 10 3. 外部中断服务。外部中断可发生在上升沿和下降沿 <p>当此引脚设定为模拟输入时，请用寄存器 <i>padier</i> 位 0 关闭（"0"）此引脚的数字输入以减少漏电流。当此引脚设定禁用数字输入，在掉电模式的唤醒功能将同时被禁用。</p> <p>This pin can be used as:</p> <ol style="list-style-type: none"> 1. Port A bit zero, this pin can be programmed to set the digital input / output, weak pull-up resistor. 2. ADC analog input channel ten 3. External interrupt service. External interrupts can occur on rising and falling edges <p>When this pin is set to analog input, please use the register <i>pbdier</i> bit zero to turn off ("0") the digital input of this pin to reduce the leakage current. When this pin is set to disable the digital input, the wake-up function in power-down mode will be disabled at the same time.</p>

NO	引脚名称 Pin Name	引脚&缓冲器 类型 Pin & buffer type	功能描述 Functional description
7	PA6 / X2	IO ST / CMOS	<p>此引脚可用作：</p> <ol style="list-style-type: none"> 1. Port A 位 6，可编程设定为数字输入/输出，弱上拉电阻。 2. 使用晶体振荡器时，作 X2 用。 <p>当此引脚设定为晶体振荡功能时，请用寄存器 <i>padier</i> 位 6 关闭（"0"）此引脚的数字输入以减少漏电流。此外，亦可设定在睡眠中唤醒系统的功能；但是，当寄存器 <i>padier</i> 位 6 为"0"时，唤醒功能是被关闭的。</p> <p>This pin can be used as:</p> <ol style="list-style-type: none"> 1. Port A bit six, this pin can be programmed to set the digital input / output, weak pull-up resistor. 2. When using a crystal oscillator, use X2. <p>When this pin is set to crystal oscillation function, please use the register <i>padier</i> bit six to turn off ("0") the digital input of this pin to reduce the leakage current. In addition, you can set the function to wake up the system during sleep; however, when the register <i>padier</i> bit six is "0", the wake-up function is turned off.</p>
8	PA7 / X1	IO ST / CMOS	<p>此引脚可用作：</p> <ol style="list-style-type: none"> 1. Port A 位 7，并可编程设定为数字输入/输出，弱上拉电阻。 2. 使用晶体振荡器时，作 X1 用。 <p>当此引脚设定为晶体振荡功能时，请用寄存器 <i>padier</i> 位 7 关闭（"0"）此引脚的数字输入以减少漏电流。此外，亦可设定在睡眠中唤醒系统的功能；但是，当寄存器 <i>padier</i> 位 7 为"0"时，唤醒功能是被关闭的。</p> <p>This pin can be used as:</p> <ol style="list-style-type: none"> 1. Port A bit seven, this pin can be programmed to set the digital input / output, weak pull-up resistor. 2. When using a crystal oscillator, use X1. <p>When this pin is set to crystal oscillation function, please use the register <i>padier</i> bit seven to turn off ("0") the digital input of this pin to reduce the leakage current. In addition, you can set the function to wake up the system during sleep; however, when the register <i>padier</i> bit seven is "0", the wake-up function is turned off.</p>
9	MCUVDD	P	单片机电源 Microcontrollers power supply

NO	引脚名称 Pin Name	引脚&缓冲器 类型 Pin & buffer type	功能描述 Functional description
10	PA5 / RESETB	IO (OC) ST / CMOS	<p>此引脚可用作：</p> <ol style="list-style-type: none"> 1. 当单片机的硬件外部复位。 2. 当 Port A 位 5; 此引脚没有上拉电阻, 此引脚可以设定为输入或开漏输出 (open drain) 模式。 <p>这个引脚可以设定在睡眠中唤醒系统的功能; 但是, 当寄存器 <i>padier</i> 位 5 为 "0" 时, 唤醒功能是被关闭的。另外, 当此引脚设定成输入时, 对于需要高抗干扰能力的系统, <u>请串接 33Ω电阻。</u></p> <p>This pin can be used as:</p> <ol style="list-style-type: none"> 1. As the microcontroller hardware external reset. 2. When Port A bit five; this pin has no pull-up resistor, this pin can be set the input or open drain output mode. <p>This pin can set the wake-up function in sleep; however, when the register <i>padier</i> bit five is "0", the wake-up function is turned off. <u>In addition, when this pin is set to input, for systems that require high anti-interference capability, please connect 33Ω resistor.</u></p>
11	PB7 / AD7 / PWM2	IO ST / CMOS / Analog	<p>此引脚可用作：</p> <ol style="list-style-type: none"> 1. Port B 位 7, 这个引脚可编程设定为数字输入/输出, 弱上拉电阻。 2. ADC 模拟输入通道 7 3. Timer3 的 PWM 输出。 <p>当此引脚设定为模拟输入时, 请用寄存器 <i>pbdir</i> 位 7 关闭 ("0") 此引脚的数字输入以减少漏电流。当此引脚设定禁用数字输入, 在掉电模式的唤醒功能将同时被禁用。</p> <p>This pin can be used as:</p> <ol style="list-style-type: none"> 1. Port B bit seven, this pin can be programmed to set the digital input / output, weak pull-up resistor. 2. ADC analog input channel seven 3. Timer three PWM output <p>When this pin is set to analog input, please use the register <i>pbdir</i> bit seven to turn off ("0") the digital input of this pin to reduce the leakage current. When this pin is set to disable the digital input, the wake-up function in power-down mode will be disabled at the same time.</p>

NO	引脚名称 Pin Name	引脚&缓冲器 类型 Pin & buffer type	功能描述 Functional description
12	PB4 / AD4 / PWM1	IO ST / CMOS / Analog	<p>此引脚可用作：</p> <ol style="list-style-type: none"> 1. Port B 位 4，这个引脚可编程设定为数字输入/输出，弱上拉电阻。 2. ADC 模拟输入通道 4 3. Timer2 的 PWM 输出。 <p>当此引脚设定为模拟输入时，请用寄存器 <i>pbdir</i> 位 4 关闭（"0"）此引脚的数字输入以减少漏电流。当此引脚设定禁用数字输入，在掉电模式的唤醒功能将同时被禁用。</p> <p>This pin can be used as:</p> <ol style="list-style-type: none"> 1. Port B bit four, this pin can be programmed to set the digital input / output, weak pull-up resistor. 2. ADC analog input channel four 3. Timer two PWM output <p>When this pin is set to analog input, please use the register <i>pbdir</i> bit four to turn off ("0") the digital input of this pin to reduce the leakage current. When this pin is set to disable the digital input, the wake-up function in power-down mode will be disabled at the same time.</p>
13	RFVDD	P	无线芯片电源 Wireless chip power supply
14	XC1	AI	无线芯片晶振脚 Wireless chip crystal pin
15	XC2	AO	无线芯片晶振脚 *注 Wireless chip crystal pin *remark
16	GND	G	无线芯片和单片机公共地 Wireless chips and microcontrollers common ground
<p>注意 : IO : 输入/输出 ; ST : 施密特触发器输入 ; AI / AO : 模拟输入/输出引脚 ; CMOS : CMOS 电压基准位</p> <p>Note: IO: input / output; ST: Schmidt flip-flop input; AI / AO: analog input / output pin; CMOS: CMOS voltage reference bit</p>			

*注 必须使用 16MHz 晶振，匹配电容需根据晶振微调。晶振精度要求：250K 通信模式±10ppm，1M 通信模式±20ppm。

Remark: The 16MHz crystal must be used, and the matching capacitor must be tuned according to the crystal. Crystal oscillator accuracy requirements: 250K communication mode±10ppm, 1M communication mode±20ppm.

2.3 芯片控制连接 (Chip control connection)

表2.2芯片控制连接 (Table 2.2 Chip control connection)

RF	MCU	说明
CSN	PB1	内部绑线连接 Internal tie connection
SCK	PB0	内部绑线连接 Internal tie connection
MOSI	PB2	内部绑线连接 Internal tie connection
MISO	PB6	内部绑线连接 Internal tie connection
IRQ	PB5	内部绑线连接 Internal tie connection

3 应用原理图 (Typical Application Schematic)

3.1 减少外围器件 (Reduce peripheral devices)

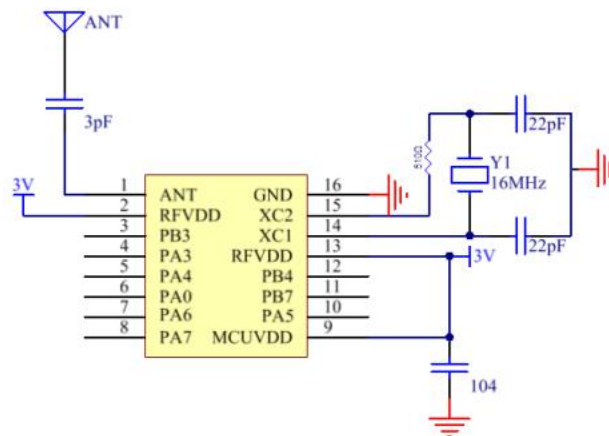

*注 部分晶振低温条件下，需要在 XC2 输出端串联 510R 电阻，提高频率输出的稳定度。

Remark: Part of the crystal under low temperature conditions, the 510R resistor is required to be connected in series at the XC2 output, to improve the stability of the frequency output.

3.2 通过安规认证 (Through security certification)

配置发射功率 5dBm 档位，射频外围匹配如下图所示（左端是 ANT 引脚），安规认证各次谐波余量为 3dB 以上：

Configure transmit power 5dBm gear, RF external matching as shown below (the left end is the ANT pin), Safety certification, each harmonic margin of more than 3dB:

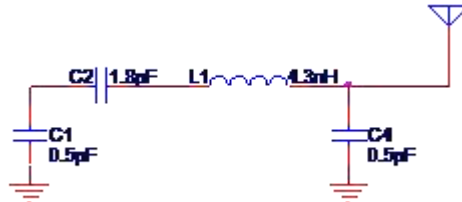

以遥控车方案为例，使用 250Kbps 通信数据率，稳定通信距离在 40m~50m 左右。

For example, the remote control car uses 250Kbps communication data rate to stabilize the communication distance from 40m to 50m.

4 封装尺寸 (Package size)

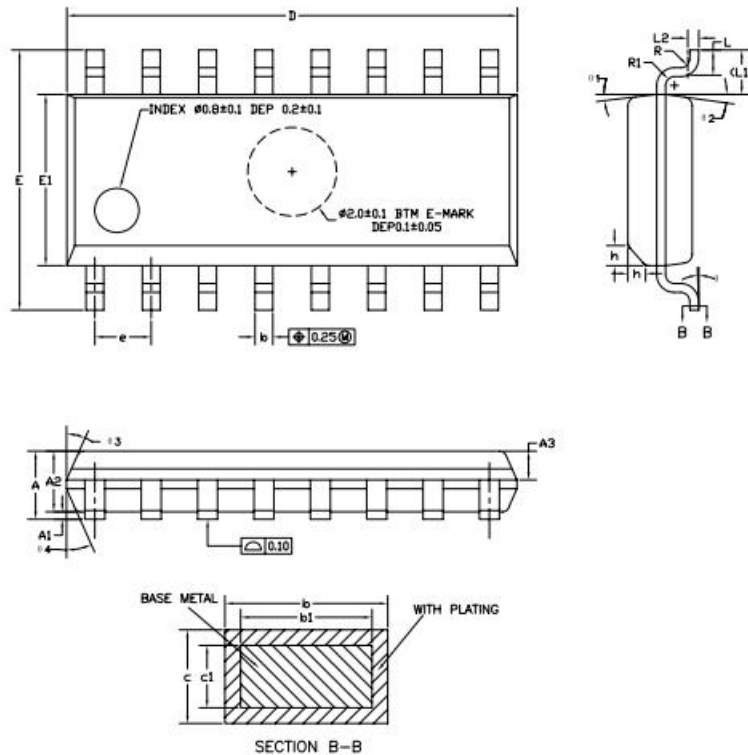

COMMON DIMENSIONS
(UNITS OF MEASURE=MILLIMETER)

SYMBOL	MIN	NOM	MAX
A	1.35	1.60	1.75
A1	0.10	0.15	0.25
A2	1.25	1.45	1.65
A3	0.55	0.65	0.75
△ b	0.36	—	0.51
b1	0.35	0.40	0.45
△ c	0.17	—	0.25
△ c1	0.17	0.20	0.23
D	9.80	9.90	10.00
E	5.80	6.00	6.20
E1	3.80	3.90	4.00
e	1.27BSC		
L	0.45	0.60	0.80
L1	1.04REF		
L2	0.25BSC		
R	0.07	—	—
R1	0.07	—	—
h	0.30	0.40	0.50
θ	0°	—	8°
θ 1	6°	8°	10°
θ 2	6°	8°	10°
θ 3	5°	7°	9°
θ 4	5°	7°	9°

图3.1 HF2404封装尺寸

5 联系方式 (Contact information)

东莞市昊沣电子科技有限公司

DongGuan HaoFeng Electronic Technology Co., LTD

地址：东莞市常平镇站前一路8号，汇隆大厦1005室

Room 1005, Huilong Building, No.8, Zhanqian Road, Banshi Village, Changping Town, Dongguan City, Guangdong province, China

电邮：haofeng_hf@126.com

Email : haofeng_hf@126.com