

Technical Description

The Equipment Under Test (EUT) is a portable 2.4GHz Transceiver (Drone Unit) for a Controller operated at 2455-2479MHz. The EUT is powered by 1 X 3.7V Rechargeable battery. After switch on the EUT and paired with RC Controller, the RC Drone can be controlled to fly forward, backward, turning left/ right direction by the controller.

The Equipment Under Test (EUT) operates at frequency range of 2412MHz to 2462MHz with 11 channels.

For 802.11b mode, it operates at frequency range of 2412.000MHz to 2462.000MHz with 11 channels. It transmits via Direct-sequence spread spectrum (DSSS) modulation. Maximum bit rate can be up to 11Mbps. For 802.11g mode, it operates at frequency range of 2412.000MHz to 2462.000MHz with 11 channels. It transmits via Orthogonal Frequency Division Multiplexing (OFDM) modulation. Maximum bit rate can be up to 54Mbps.

The brief circuit description is listed as below:

2.4GHz RF Module:

- 1) U2 acts as Gyroscope (MPU6050).**
- 2) U1 acts as MCU (2181FHNQ(QFN48)).**
- 3) Y1 is 12MHz Crystal Oscillator for U1.**
- 4) U3 acts as MEMS (SPL006).**
- 5) U4 and U5 act as Voltage Regulator (HX3001, MIC5219).**

WIFI Module:

- 6) U4 and U7 acts as Voltage Regulator (TD6016).**
- 7) U6 acts as SPI Flash (W25Q16).**
- 8) U9 acts as Voltage Regulator (XC6206-2.8V).**
- 9) U2 acts as MCU (DSP6703).**
- 10) Y1 is 24MHz Crystal Oscillator for U2.**
- 11) U8 acts as 2.4GHz Wifi Module Circuit (WIFI_88W8801).**
- 12) Y2 is 38.4MHz Crystal Oscillator for U2.**
- 13) U3 acts as Sensor (HY6001).**

2.4GHz RF Module:

Antenna Type: Internal antenna

Antenna Gain: 0dBi

Nominal rated field strength: 86.2dB μ V/m at 3m

Maximum allowed field strength of production tolerance: +/- 3dB

Wifi Module:

Antenna Type: Internal antenna

Antenna Gain: 0dBi

Operating mode	Nominal Conducted Power	Production Tolerance	Modulation Type
802.11b	15.79dBm	+/-2dB	DSSS
802.11g	21.87dBm	+/-2dB	OFDM

8801M1

Product Specification

IEEE 802.11b/g/n WLAN SDIO Module

Content

Content	1
0. Revision History	2
1. General Description	2
2. The range of applying	2
3. Product Specification	2
3.1 Function Block diagram	2
3.2 Electrical and Performance Specification	3
3.5 Product Photo	4
3.6 Mechanical Specification	5
3.7 Product Pin Definition	5
4. Supported platform.....	6
5. Peripheral Schematic Reference Design	6
5.1 WIFI RF Circuit reference pictures	6
6. Typical Solder Reflow Profile	7

0. Revision History

Date	Document revision	Product revision	Change Description
2014/11/11	0.1	V0.1	Draft initial release

1. General Description

BL-R8801MS1 product is designed base on MARVELL 88W8801 chipset .It is a highly integrated single-band (2.4GHz) IEEE 802.11n 1X1 System-on-Chip (SoC), specifically designed to support High Throughput data rates for next generation WLAN products. It supports IEEE802.11i safety protocol, along with IEEE 802.11e standard service quality. It supports the new data encryption on 64/128 bit WEP and safety mechanism on WPA-PSK/WPA2- PSK, WPA/WPA2. It can implement the wireless network function on the laptop/desktop/MID and other wireless devices easily .

2. The range of applying

MID, networking camera, STB GPS, E-book, Hard disk player, Network Radios, PSP and other device which need be supported by wireless networking.

3. Product Specification

3.1 Function Block diagram

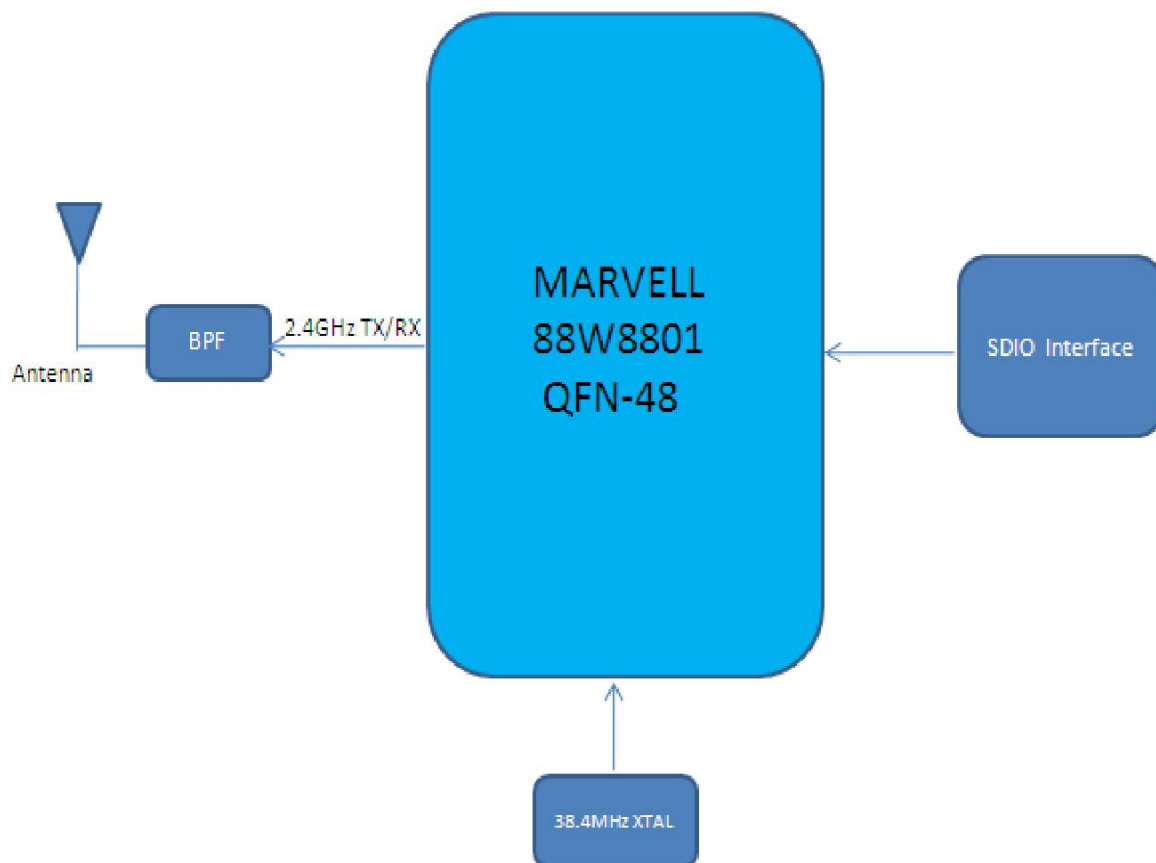

3.2 Electrical and Performance Specification

Item	Description
Product Name	BL-R8801MS1
Major Chipset	MARVELL 88W8801
Host Interface	SDIO
Standard	IEEE 802.11b, IEEE 802.11g, IEEE 802.11n,
Frequency Range	2.4GHz~2.4835GHz
Modulation Type	802.11b: CCK, DQPSK, DBPSK 802.11g: 64-QAM, 16-QAM, QPSK, BPSK 802.11n: 64-QAM, 16-QAM, QPSK, BPSK
Working Mode	Infrastructure, Ad-Hoc
Data Transfer Rate	1,2,5.5,6,11,12,18,22,24,30,36,48,54, and maximum of 72.2Mbps
Spread Spectrum	IEEE 802.11b: DSSS (Direct Sequence Spread Spectrum) IEEE 802.11g/n: OFDM (Orthogonal Frequency Division

	Multiplexing)
Sensitivity @PER	1M: <u>-92dBm@8%PER</u> 6M: <u>-88dBm@10%PER</u> 11M: <u>-86dBm@8%PER</u> 54M: <u>-72dBm@10%PER</u> 72.2M: <u>-68dBm@10%PER</u>
RF Power	17dBm@11b,14dBm@11g ,13dBm@11n
Antenna type	Connect to the external antenna through the half hole
The transmit distance	Indoor 100M, Outdoor 300M, according the local environment
Dimension(L*W*H)	13 x 13.5 x 1.46mm (LxWxH) ;Tolerance: +-0.15mm
Power supply	3.3V +/-0.2V
Power Consumption	standby mode 80mA@3.3V , TX mode 250mA@3.3V
Clock source	38.4MHz
Working Temperature	-40°C to +85°C
Storage temperature	-55°C ~ +125°C

3.3 Product Photo

TOP

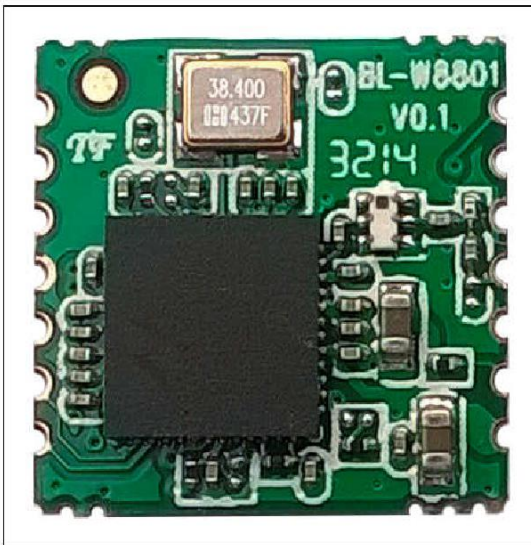

Bottom

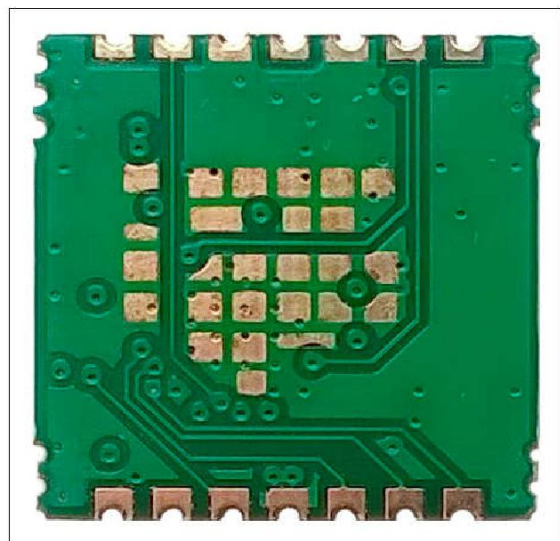

3.4 Mechanical Specification

Module dimension: Typical (W x L x H): 13mmx13.5mmx1.46mm
0.15mm

Tolerance : +/- 0.15mm

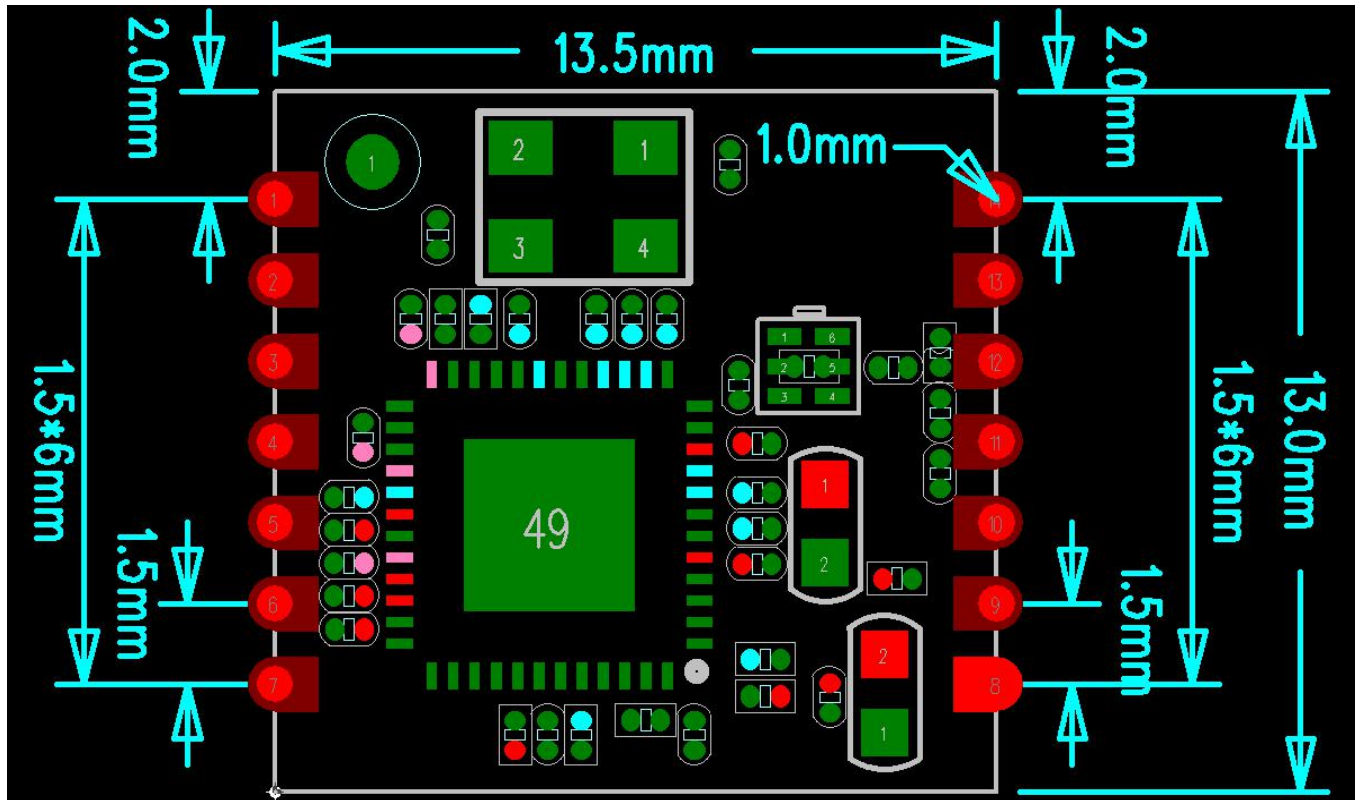

3.5 Product Pin Definition

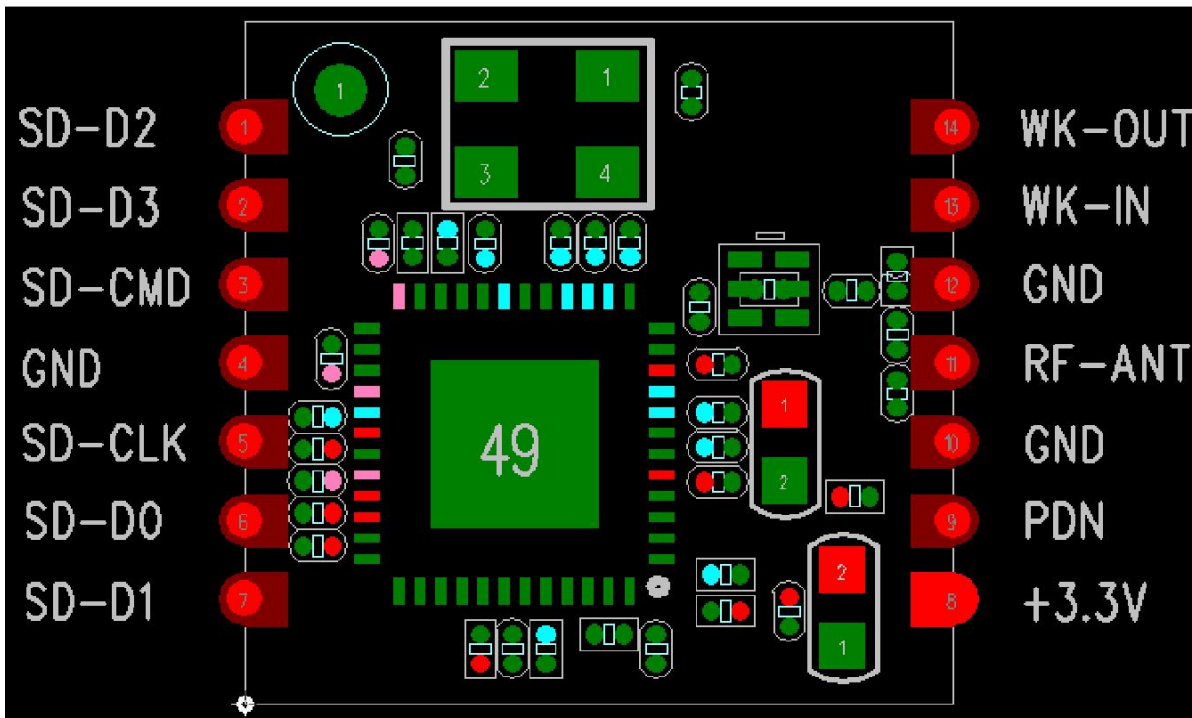

4. Supported platform

Support Linux platform.

5. Peripheral Schematic Reference Design

5.1 WiFi RF Circuit reference pictures

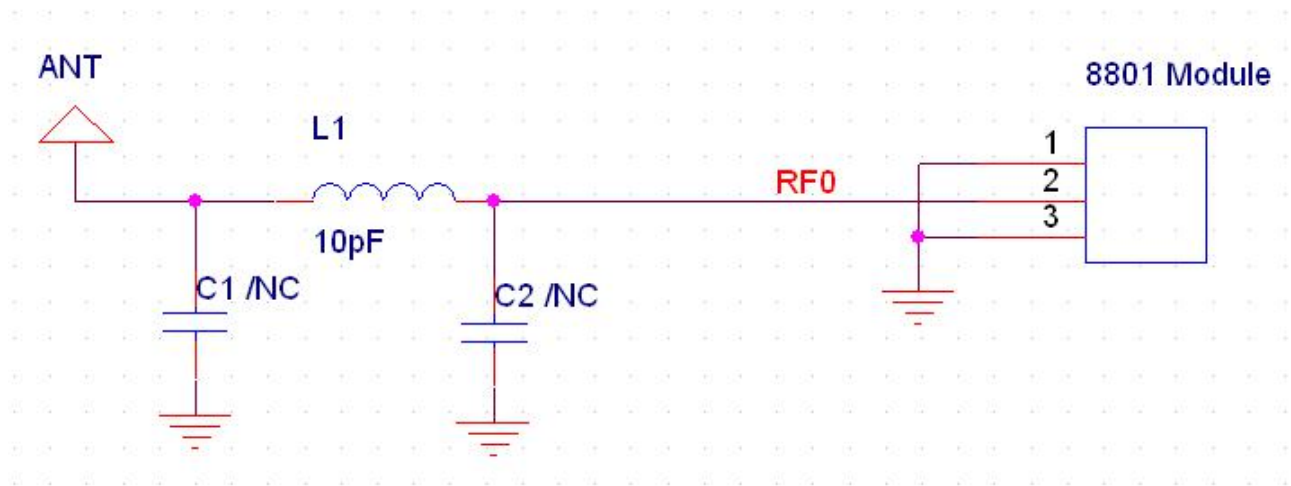

Pls reserve a “pi” circuit for antenna matching. The “pi” circuit’s value depends on the matching result.

6. Typical Solder Reflow Profile

