

Standard Scale 200%

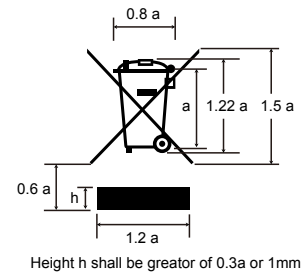

Standard Scale 100%

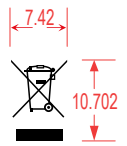

Standard Scale 200%

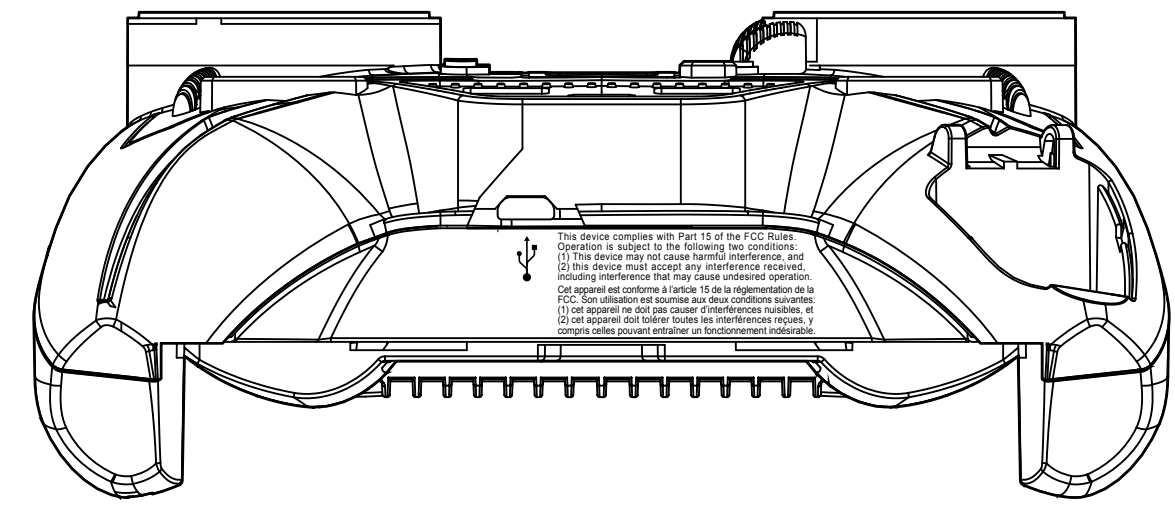
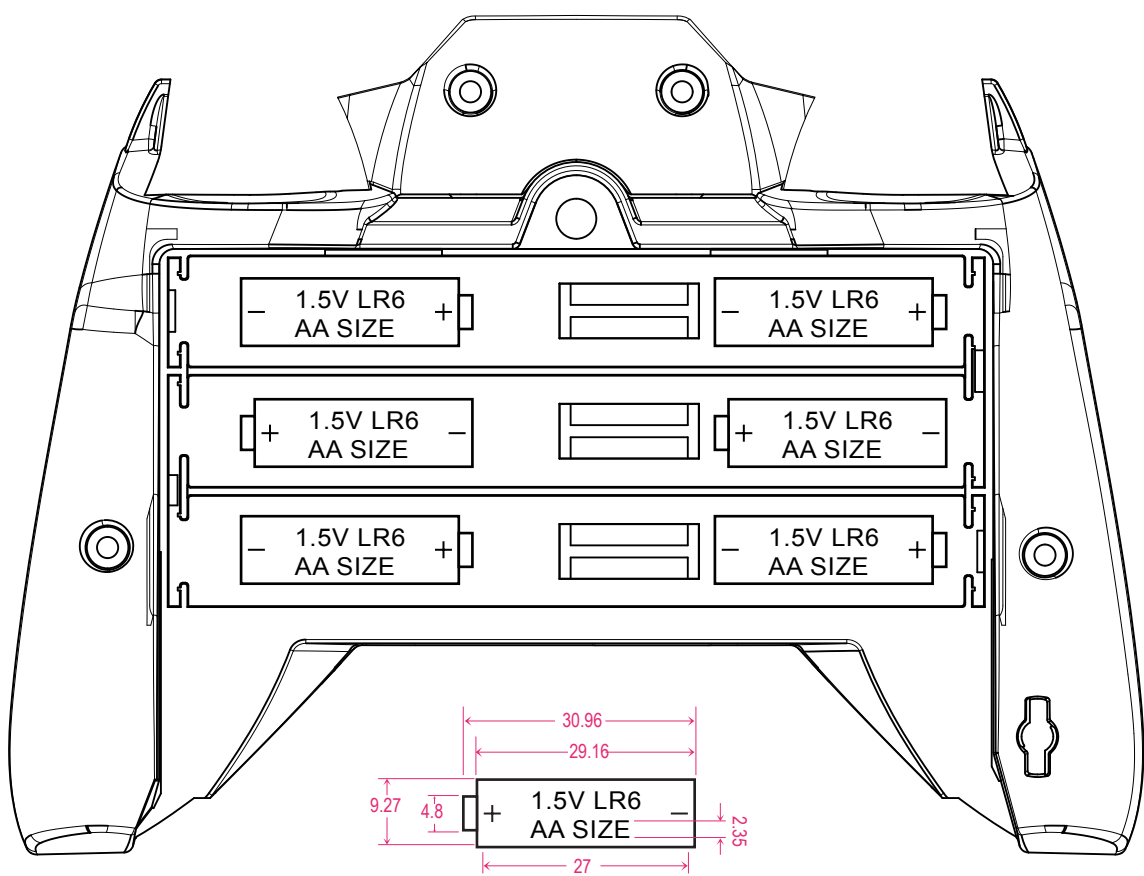
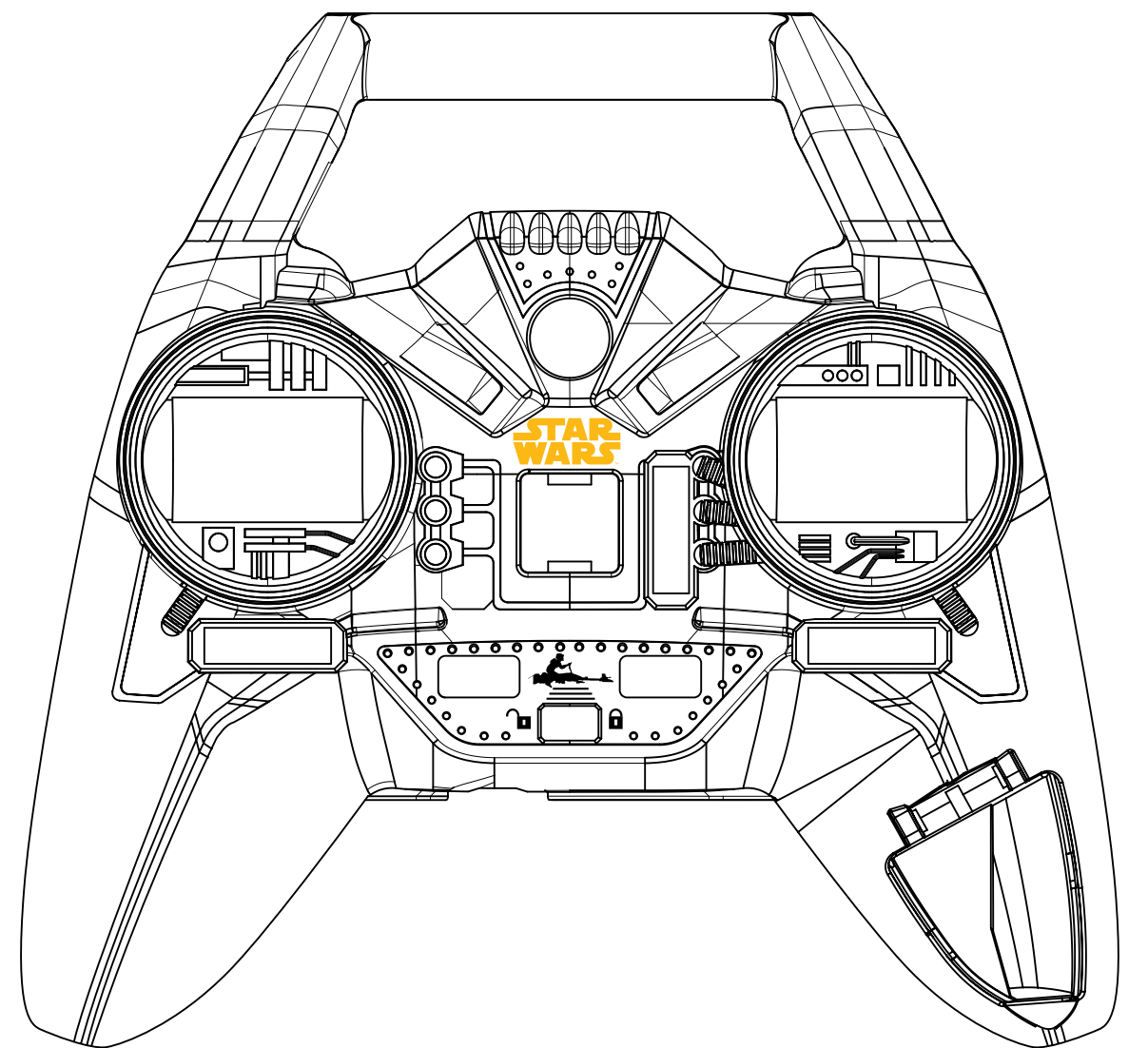
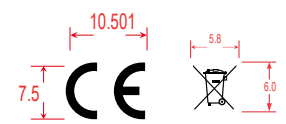
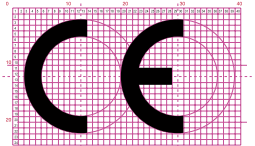

This device complies with Part 15 of the FCC Rules. Operation is subject to the following two conditions:
 (1) This device may not cause harmful interference, and
 (2) this device must accept any interference received, including interference that may cause undesired operation.
 Cet appareil est conforme à l'article 15 de la réglementation de la FCC. Son utilisation est soumise aux deux conditions suivantes:
 (1) cet appareil ne doit pas causer d'interférences nuisibles, et
 (2) cet appareil doit tolérer toutes les interférences reçues, y compris celles pouvant entraîner un fonctionnement indésirable.

Tampo Plate Art Work

