

44542# Batwing Plane TX BLOCK DIAGRAM

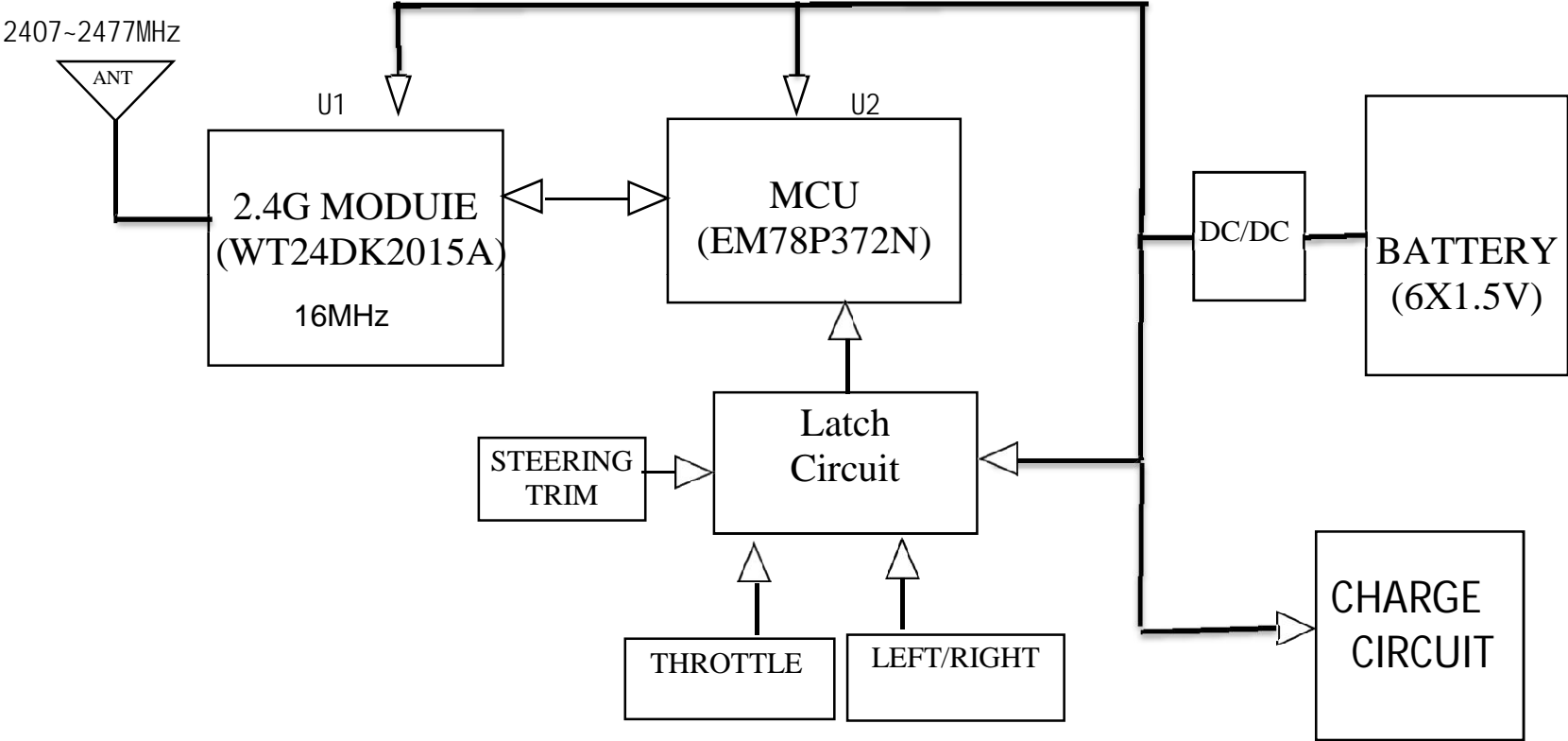

1 INTRODUCTION

SSV7241 is a single chip GFSK transceiver operating at ISM frequency band of 2400 to 2483.5 MHz for low-power wireless applications. Using advanced CMOS technology and optimized radio architecture, SSV7241 has excellent radio performance, low current consumption, and a low bill of material (BOM). SSV7241 is suitable for low-cost and low-power applications such as wireless PC peripherals. Furthermore, SSV7241's advanced features and ability to be set in continuous TX mode makes it an excellent choice for demanding applications such as wireless audio/headsets.

SSV7241 can be easily configured through Serial Peripheral Interface (SPI). A complete radio system can be built with a simple low-end microcontroller (MCU) and only a few external passive components. Packet processing, auto-retransmission, and auto-acknowledgement protocols are integrated into SSV7241's radio baseband engine, hence reducing the computation load of MCU.

SSV7241's radio can be configured based on user requirements. Frequency channels can be set in 1 MHz increment. SSV7241 supports 250kbps, 1Mbps, and 2Mbps air data rate.

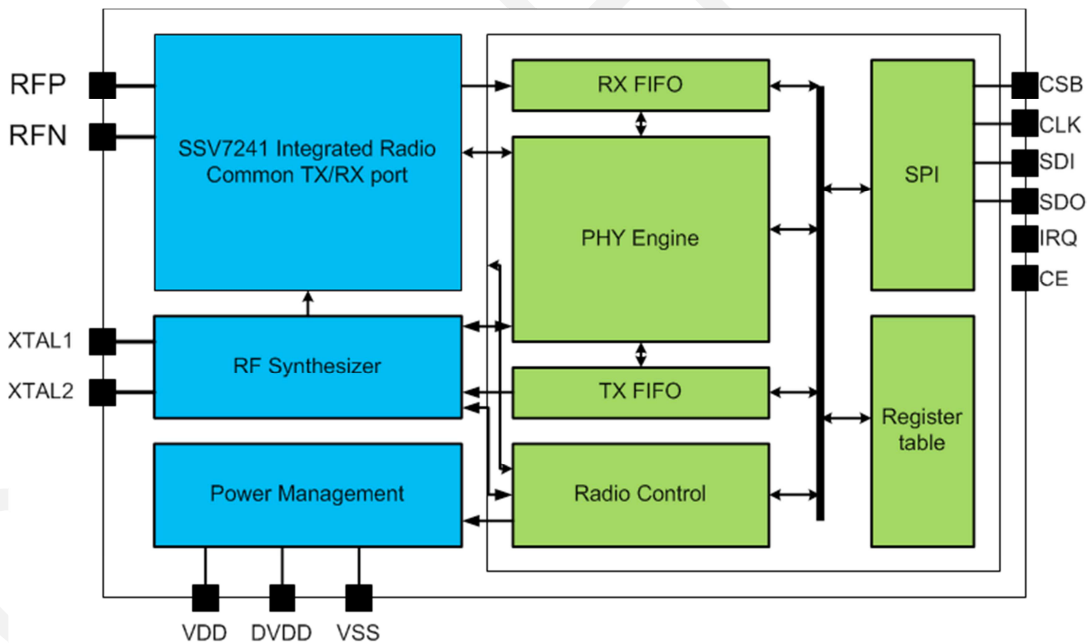

Figure 1: Block diagram of SSV7241