

#44483 Hypertrax Tank TX

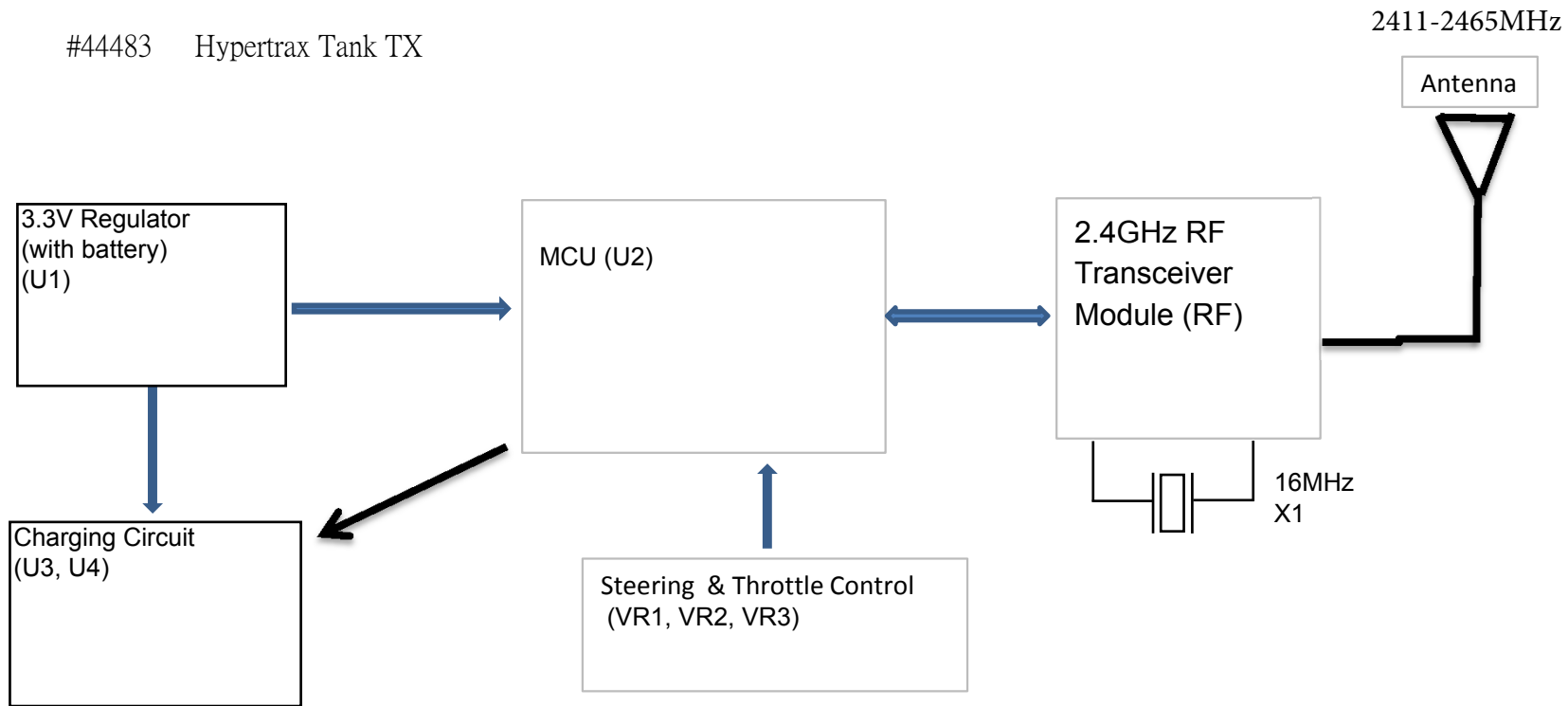

(RF) 2.4GHz RF Transceiver Module Block Diagram

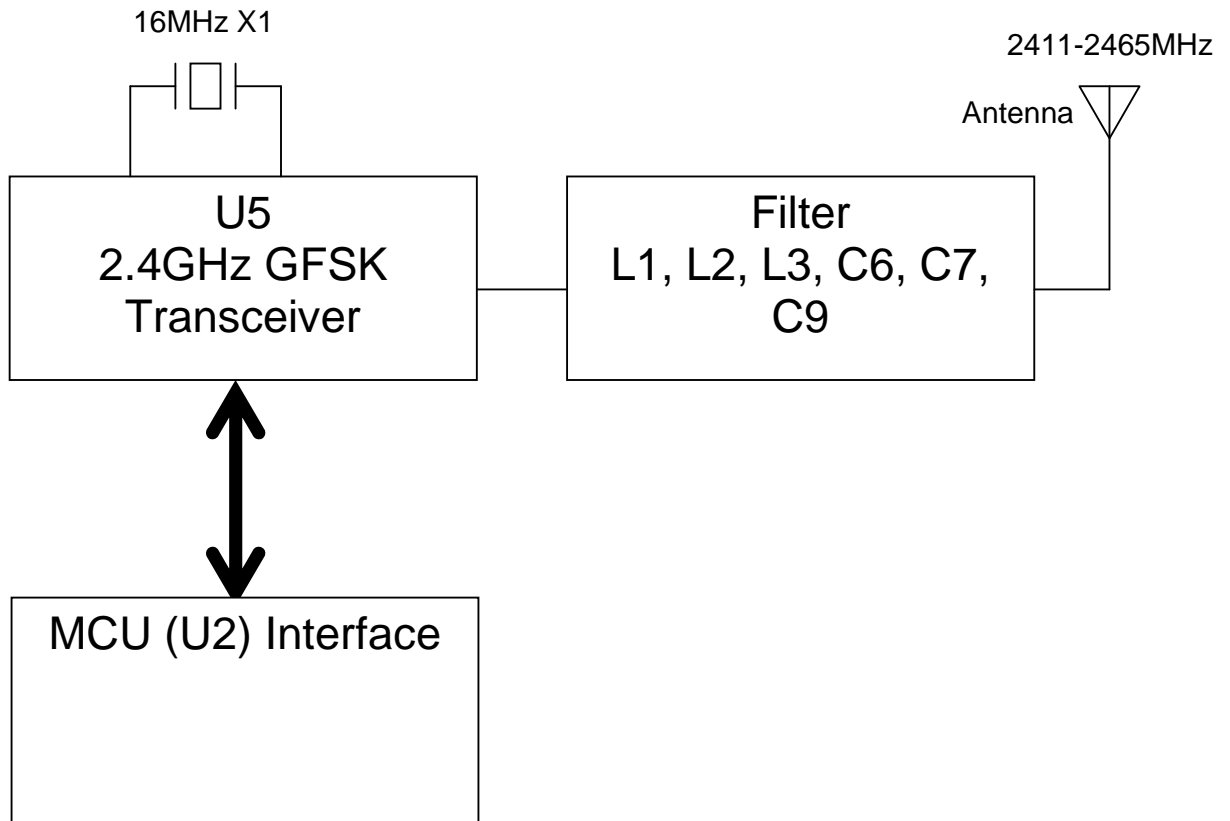



BK2423

Low Power High Performance 2.4 GHz GFSK Transceiver

Features

- 2400-2483.5 MHz ISM band operation
- Support 250Kbps, 1Mbps and 2 Mbps air data rate
- Programmable output power
- Low power consumption
- Tolerate +/- 60ppm 16 MHz crystal
- Variable payload length from 1 to 32bytes
- Automatic packet processing
- 6 data pipes for 1:6 star networks
- 1.9V to 3.6V power supply
- 4-pin SPI interface with maximum 8 MHz clock rate
- Compact 20-pin 3x3 or 4x4mm QFN package

Pin Assignments

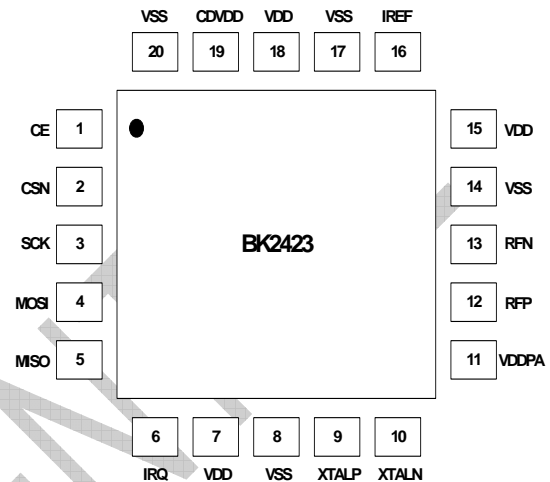

Applications

- Wireless PC peripherals
- Wireless mice and keyboards
- Wireless gamepads
- Wireless audio
- VOIP and wireless headsets
- Remote controls
- Consumer electronics
- Home automation
- Toys
- Personal health and entertainment

Block Diagram

