

Technical Description:

The brief circuit description is listed as follows:

U1 and Associated circuit act as MCU and 2.4GHz RF transceiver module.

PE93SP acts as Voltage Regulator

RX4056 and ETA1483 act as current control

Antenna Used:

An internal, integral antenna has been used.

Antenna Gain: 0dBi

Production tolerance: -2dBm (Minimum) to +2dBm (Maximum)

1 Introduction

The nRF24LE1 is a member of the low-cost, high-performance nRF24 family of intelligent 2.4 GHz RF Transceivers with embedded microcontrollers. The nRF24LE1 is optimized to provide a single chip solution for ULP wireless applications. The combination of processing power, memory, low power oscillators, real-time counter, AES encryption accelerator, random generator and a range of power saving modes provides an ideal platform for implementation of RF protocols. Benefits of using nRF24LE1 include tighter protocol timing, security, lower power consumption and improved co-existence performance. For the application layer the nRF24LE1 offers a rich set of peripherals including: SPI, 2-wire, UART, 6 to 12 bit ADC, PWM and an ultra low power analog comparator for voltage level system wake-up.

The nRF24LE1 comes in three different package variants:

- An ultra compact 4x4mm 24 pin QFN (7 generic I/O pins)
- A compact 5x5mm 32 pin QFN (15 generic I/O pins)
- A 7x7mm 48 pin QFN (31 generic I/O pins)

The 4x4mm 24 pin QFN is ideal for low I/O count applications where small size is key. Examples include wearable sports sensors and watches. The 5x5mm 32 pin QFN is ideal for medium I/O count applications such as wireless mouse, remote controls and toys. The 7x7mm 48 pin QFN is designed for high I/O count products like wireless keyboards.

1.1 Prerequisites

In order to fully understand the product specification, a good knowledge of electronic and software engineering is necessary.

1.2 Writing conventions

This product specification follows a set of typographic rules that makes the document consistent and easy to read. The following writing conventions are used:

- Commands, bit state conditions, and register names are written in *Courier*.
- Pin names and pin signal conditions are written in *Courier bold*.
- Cross references are [underlined and highlighted in blue](#).

2 Product overview

2.1 Features

Features of the nRF24LE1 include:

- Fast 8-bit microcontroller:
 - Intel MCS 51 compliant instruction set
 - Reduced instruction cycle time, up to 12x compared to legacy 8051
 - 32 bit multiplication – division unit
- Memory:
 - Program memory: 16 kbytes of Flash memory with security features (up to 1k erase/ write cycles)
 - Data memory: 1 kbytes of on-chip RAM memory
 - Non-volatile data memory: 1 kbyte
 - Non-volatile data memory extended endurance: 512 bytes (up to 20k erase/ write cycles)
- A number of on-chip hardware resources are available through programmable multi purpose input/output pins (7-31 pins dependent on package variant):
 - GPIO
 - SPI master
 - SPI slave
 - 2-Wire master/ slave
 - Full duplex serial port
 - PWM
 - ADC
 - Analog comparator
 - External interrupts
 - Timer inputs
 - 32 kHz crystal oscillator
 - Debug interface
- High performance 2.4 GHz RF-transceiver
 - True single chip GFSK transceiver
 - Complete OSI Link Layer in hardware
 - Enhanced ShockBurst™ link layer support in HW:
 - Packet assembly/disassembly
 - Address and CRC computation
 - Auto ACK and retransmit
 - On the air data rate 250 kbps, 1 Mbps or 2 Mbps
 - Digital interface (SPI) speed 0-8 Mbps
 - 125 RF channel operation, 79 (2.402-2.81 GHz) channels within 2.400 - 2.4853 GHz.
 - Short switching time enable frequency hopping
 - Fully RF compatible with nRF24LXX
 - RF compatible with nRF2401A, nRF2402, nRF24E1, nRF24E2 in 250 kbps and 1 Mbps mode
- A/D converter:
 - 6, 8, 10 or 12 bit resolution
 - 14 input channels
 - Single ended or differential input
 - Full-scale range set by internal reference, external reference or VDD
 - Single step mode with conversion time down to 3μs
 - Continuous mode with 2, 4, 8 or 16 kbps sampling rate
 - Low current consumption; only 0.1 mA at 2 ksps
 - Mode for measuring supply voltage

- Analog comparator:
 - ▶ Used as wakeup source
 - ▶ Low current consumption (0.75µA typical)
 - ▶ Differential or single-ended input
 - ▶ Single-ended threshold programmable to 25%, 50%, 75% or 100% of VDD or an arbitrary reference voltage from pin
 - ▶ 14-channel input multiplexer
 - ▶ Rail-to-rail input voltage range
 - ▶ Programmable output polarity
- Encryption/decryption Co-processor
 - ▶ Utilize time and power effective AES firmware
- Random number generator:
 - ▶ Non-deterministic architecture based on thermal noise
 - ▶ No seed value required
 - ▶ Non-repeating sequence
 - ▶ Corrector algorithm ensures uniform statistical distribution
 - ▶ Data rate up to 10 kilobytes per second
 - ▶ Operational while the processor is in standby
- System reset and power supply monitoring:
 - ▶ On-chip power-on and brown-out reset
 - ▶ Watchdog timer reset
 - ▶ Reset from pin
 - ▶ Power-fail comparator with programmable threshold and interrupt to MCU
- On-chip timers:
 - ▶ Three 16-bit timers/counters operating at the system clock (sources from the 16 MHz on-chip oscillators)
 - ▶ One 16-bit timer/counter operating at the low frequency clock (32 kHz)
- On-chip oscillators:
 - ▶ 16 MHz crystal oscillator XOSC16M
 - ▶ 16 MHz RC-oscillator RCOSC16M
 - ▶ 32 kHz crystal oscillator XOSC32K
 - ▶ 32 kHz RC-oscillator RCOSC32K
- Power management function:
 - ▶ Low power design supporting fully static stop/ standby
 - ▶ Programmable MCU clock frequency from 125KHz to 16 MHz
 - ▶ On chip voltage regulators supporting low power mode
 - ▶ Watchdog and wakeup functionality running in low power mode
- On chip support for FS2 or nRFprobe™ HW debugger, supported by Keil development tools.
- Complete firmware platform available:
 - ▶ Hardware abstraction layer (HAL) Functions
 - ▶ nRF24L01+ Library functions
 - ▶ AES HAL
 - ▶ Application examples

2.3 Pin assignments

2.3.2 32-pin 5x5 QFN-package variant

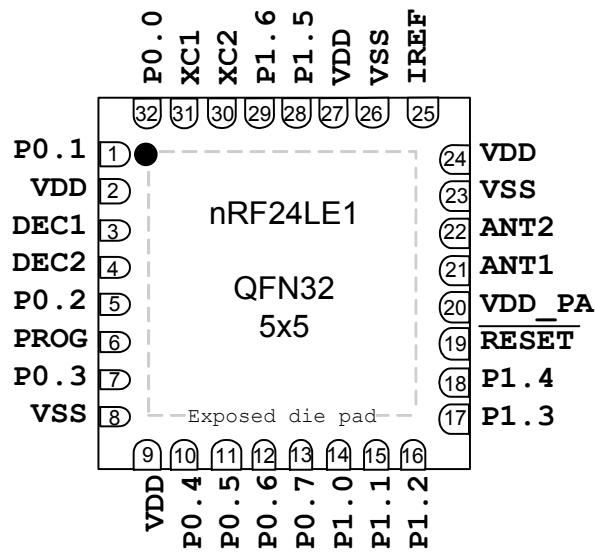

Figure 3. nRF24LE1 pin assignment (top view) for a QFN32 5x5 mm package.

2.4 Pin functions

Name	Type	Description
VDD	Power	Power supply (+1.9V to +3.6V DC)
VSS	Power	Ground (0V)
DEC1 DEC2	Power	Power supply outputs for de-coupling purposes (100nF for DEC1, 33nF for DEC2)
P3.6 – P0.0	Digital or analog I/O	General purpose I/O pins. Number of I/O available depends on package type.
PROG	Digital Input	Input to enable flash programming
RESET	Digital Input	Reset for microcontroller, active low
IREF	Analog Input	Device reference current output. To be connected to reference resistor on PCB.
VDD_PA	Power Output	Power supply output (+1.8V) for on-chip RF Power amplifier
ANT1, ANT2	RF	Differential antenna connection (TX and RX)
XC1, XC2	Analog Input	Crystal connection for 16M crystal
Exposed die pad	Power/heat relief	For the nRF24LE1 QFN48 7x7mm and QFN32 5x5mm connect the die pad to GND. For nRF24LE1 QFN24 4x4mm do not connect the die pad to GND.

Table 2. nRF24LE1 pin functions.