



**Document Title**

A7105 Data Sheet, 2.4GHz FSK/GFSK Transceiver with 500Kbps data rate

**Revision History**

<b><u>Rev. No.</u></b>	<b><u>History</u></b>	<b><u>Issue Date</u></b>	<b><u>Remark</u></b>
0.0	Initial issue.	Dec 27 <sup>th</sup> , 2007	Preliminary
0.1	Modified specification and add section for TX power setting	Feb 20 <sup>th</sup> , 2008	Preliminary
0.2	Add top marking info., reflow profile, Carry tape & reel dimensions	Oct. 9 <sup>th</sup> , 2008	Preliminary
0.3	Modify description of state machine and FIFO mode Rename IRQS1/IRQS2 to GIO1S/GIO2S Rename GPIO1/GPIO2 to GIO1/GIO2 Add Easy FIFO mode, Segment FIFO mode Delete thermal sensor function / external voltage measurement Delete TWWS function Add State diagram of quick/normal/power saving FIFO mode Add State diagram of Direct mode Rename Master Clock F <sub>CSCK</sub> to F <sub>MCLK</sub> Modify data rate support from 1K~500K to 2K ~ 500K	Jan. 7 <sup>th</sup> , 2009	Preliminary

AMICCOM CONFIDENTIAL

**Important Notice:**

AMICCOM reserves the right to make changes to its products or to discontinue any integrated circuit product or service without notice. AMICCOM integrated circuit products are not designed, intended, authorized, or warranted to be suitable for use in life-support applications, devices or systems or other critical applications. Use of AMICCOM products in such applications is understood to be fully at the risk of the customer.



**Table of Contents**

1. General Description..... 5

2. Typical Applications ..... 5

3. Feature..... 5

4. Pin Configurations ..... 6

5. Pin Description (I: input; O: output, I/O: input or output)..... 6

6. Chip Block Diagram..... 7

7. Absolute Maximum Ratings..... 8

8. Electrical Specification..... 8

9. Control Register ..... 10

    9.1 Control register table..... 10

    9.2 Control register description ..... 12

        9.2.1 Mode Register (Address: 00h)..... 12

        9.2.2 Mode Control Register (Address: 01h)..... 12

        9.2.3 Calibration Control Register (Address: 02h)..... 13

        9.2.4 FIFO Register I (Address: 03h)..... 13

        9.2.5 FIFO Register II (Address: 04h)..... 13

        9.2.6 FIFO DATA Register (Address: 05h)..... 13

        9.2.7 ID DATA Register (Address: 06h)..... 14

        9.2.8 RC OSC Register I (Address: 07h)..... 14

        9.2.9 RC OSC Register II (Address: 08h)..... 14

        9.2.10 RC OSC Register III (Address: 09h)..... 14

        9.2.11 CKO Pin Control Register (Address: 0Ah)..... 14

        9.2.12 GIO1 Pin Control Register I (Address: 0Bh)..... 15

        9.2.13 GIO2 Pin Control Register II (Address: 0Ch)..... 15

        9.2.14 Clock Register (Address: 0Dh)..... 16

        9.2.15 Data Rate Register (Address: 0Eh)..... 17

        9.2.16 PLL Register I (Address: 0Fh)..... 17

        9.2.17 PLL Register II (Address: 10h)..... 17

        9.2.18 PLL Register III (Address: 11h)..... 17

        9.2.19 PLL Register IV (Address: 12h)..... 17

        9.2.20 PLL Register V (Address: 13h)..... 18

        9.2.21 TX Register I (Address: 14h)..... 18

        9.2.22 TX Register II (Address: 15h)..... 18

        9.2.23 Delay Register I (Address: 16h)..... 19

        9.2.24 Delay Register II (Address: 17h)..... 19

        9.2.25 RX Register (Address: 18h)..... 19

        9.2.26 RX Gain Register I (Address: 19h)..... 20

        9.2.27 RX Gain Register II (Address: 1Ah)..... 20

        9.2.28 RX Gain Register III (Address: 1Bh)..... 20

        9.2.29 RX Gain Register IV (Address: 1Ch)..... 20

        9.2.30 RSSI Threshold Register (Address: 1Dh)..... 21

        9.2.31 ADC Control Register (Address: 1Eh)..... 21

        9.2.32 Code Register I (Address: 1Fh)..... 21

        9.2.33 Code Register II (Address: 20h)..... 22

        9.2.34 Code Register III (Address: 21h)..... 22

        9.2.35 IF Calibration Register I (Address: 22h)..... 22

        9.2.36 IF Calibration Register II (Address: 23h)..... 22

        9.2.37 VCO current Calibration Register (Address: 24h)..... 23

        9.2.38 VCO Single band Calibration Register I (Address: 25h)..... 23

        9.2.39 VCO Single band Calibration Register II (Address: 26h)..... 23

        9.2.40 Battery detect Register (Address: 27h)..... 24



9.2.41 TX test Register (Address: 28h).....24

9.2.42 Rx DEM test Register I (Address: 29h).....24

9.2.43 Rx DEM test Register II (Address: 2Ah).....25

9.2.44 Charge Pump Current Register (Address: 2Bh).....25

9.2.45 Crystal test Register (Address: 2Ch).....25

9.2.46 PLL test Register (Address: 2Dh).....25

9.2.47 VCO test Register I (Address: 2Eh).....25

9.2.48 VCO test Register II (Address: 2Fh).....26

9.2.49 IFAT Register (Address: 30h).....26

9.2.50 RScale Register (Address: 31h).....26

9.2.51 Filter test Register (Address: 32h).....26

10. SPI.....27

10.1 SPI Format.....28

10.2 SPI Timing Characteristic.....28

10.3 SPI Timing Chart.....29

10.3.1 Timing Chart of 3-wire SPI.....29

10.3.2 Timing Chart of 4-wire SPI.....29

10.4 Strobe Commands.....30

10.4.1 Strobe Command - Sleep Mode.....30

10.4.2 Strobe Command - Idle Mode.....30

10.4.3 Strobe Command - Standby Mode.....31

10.4.4 Strobe Command - PLL Mode.....31

10.4.5 Strobe Command - RX Mode.....32

10.4.6 Strobe Command - TX Mode.....32

10.4.7 Strobe Command – FIFO Write Pointer Reset.....33

10.4.8 Strobe Command – FIFO Read Pointer Reset.....33

10.5 Reset Command.....33

10.6 ID Accessing Command.....34

10.6.1 ID Write Command.....34

10.6.2 ID Read Command.....34

10.7 FIFO Accessing Command.....35

10.7.1 TX FIFO Write Command.....35

10.7.2 Rx FIFO Read Command.....35

11. State machine.....36

11.1 Key states.....36

11.1.1 Standby mode.....37

11.1.2 Sleep mode.....37

11.1.3 Idle mode.....37

11.1.4 PLL mode.....37

11.1.5 TX mode.....37

11.1.6 RX mode.....38

11.1.7 CAL mode.....38

11.2 Normal FIFO Mode.....39

11.3 Quick FIFO Mode.....41

11.4 Power Saving FIFO Mode.....43

11.5 Quick Direct Mode.....45

12 Crystal Oscillator.....48

12.1 Use External Crystal.....48

12.2 Use external clock.....48

13. System Clock.....49

13.1 Bypass clock generation.....50

13.2 Enable clock generation.....51

14. Transceiver LO Frequency.....53

14.1 LO Frequency Setting.....54

14.2 IF Side Band Select.....56

14.2.1 Auto IF Exchange.....57



---

14.2.2 Fast Exchange.....	58
14.3 Frequency Compensation.....	59
15. Calibration.....	60
15.1 Calibration Procedure.....	60
15.2 IF Filter Bank Calibration.....	60
15.3 VCO Current Calibration.....	60
15.4 VCO Bank Calibration.....	61
16. FIFO (First In First Out).....	62
16.1 Packet Format.....	62
16.2 Bit Stream Process.....	63
16.3 Transmission Time.....	64
16.4 Usage of TX and RX FIFO.....	65
16.4.1 Easy FIFO.....	65
16.4.2 Segment FIFO.....	66
16.4.3 FIFO Extension.....	68
17. ADC (Analog to Digital Converter).....	71
17.1 RSSI Measurement.....	71
17.2 Carrier Detect.....	73
18. Battery Detect.....	73
19. TX power setting.....	74
20. Application circuit (reference only).....	75
21. Abbreviations.....	76
22. Ordering Information.....	76
23. Package Information.....	77
24. Top Marking Information.....	78
25. Reflow Profile.....	79
26. Type Reel Information.....	80

AMICCOM CONFIDENTIAL

### 1. General Description

The A7105 is a high performance and low cost 2.4GHz ISM band wireless transceiver. It integrates both high sensitivity receiver and high efficiency power amplifier (up to 1dBm). In low data rate application, A7105 has special strength for long LOS (line-of-sight) distance because of its super high sensitivity (-107 dBm @ 2Kbps) with no requirement of external LNA or PA. Based on chip fraction-N synthesizer, it can support on-air data rates from 2Kbps to 500Kbps. For packet handling, A7105 supports 64 bytes data FIFO, CRC detection, FEC error correction. In addition, 8-bits RSSI for clear channel assessment and data whitening for data encryption/decryption. That makes A7105 easy to be used together with a low cost and low speed micro-controller (MCU). All features are integrated in a small QFN 4X4 20 pins package.

One unique command set is called **Strobe command** via 3-wire or 4-wire SPI interface, MCU could access A7105's control registers and state machine for all radio control like TX delivery, RX receiving, channel monitoring, frequency hopping (ONE register setting), auto calibrations as well as power saving mode. Then, MCU could easily use either polling or interrupt scheme by monitoring A7105's two general purpose I/O pins, GIO1 and GIO2 because of its digital interface.

### 2. Typical Applications

- Wireless data communication
- Remote control
- Wireless keyboard and mice
- 2400 ~ 2483.5 MHz ISM system
- Home automation
- Wireless toy and game control

### 3. Feature

- Frequency band: 2400 ~ 2483.5MHz.
- FSK or GFSK modulation
- Low current consumption: RX 16mA, TX 19mA (at 0dBm output power).
- On chip regulator, supply input voltage 1.9 ~ 3.6 V.
- Programmable data rate from 1Kbps to 500kbps.
- Programmable TX power level from -20 dBm to 1 dBm.
- High sensitivity:
  - ◆ -95dBm at 500Kbps on-air data rate.
  - ◆ -97dBm at 250Kbps on-air data rate
  - ◆ -104dBm at 25Kbps on-air data rate
  - ◆ -107dBm at 2Kbps on-air data rate
- Fast settling time synthesizer for frequency hopping system.
- Built-in Battery Detector.
- Support low cost crystal (6 / 8 / 12 / 16 / 20 / 24MHz).
- Support crystal sharing, (1 / 2 / 4 / 8MHz) to MCU.
- Support Frequency Compensation.
- Easy to use.
  - ◆ Support 3-wire or 4-wire SPI.
  - ◆ Unique Strobe command via SPI.
  - ◆ ONE register setting for new channel frequency.
  - ◆ 8-bits Digital RSSI for clear channel indication.
  - ◆ Fast exchange mode during TRX role switching.
  - ◆ Auto RSSI measurement.
  - ◆ Auto Calibrations.
  - ◆ Auto IF function.
  - ◆ Auto CRC Check.
  - ◆ Auto FEC by (7, 4) Hamming code (1 bit error correction / code word).
  - ◆ Data Whitening for encryption and decryption.
  - ◆ Separated 64 bytes RX and TX FIFO.
  - ◆ Easy FIFO / Segment FIFO / FIFO Extension (up to 256 bytes).
  - ◆ Support direct mode with recovery clock output to MCU.
  - ◆ Support direct mode with frame sync signal to MCU.

### 4. Pin Configurations

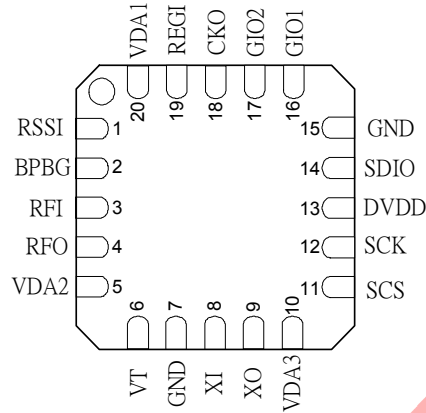

Fig 4-1. A7105 QFN Package Top View

### 5. Pin Description (I: input; O: output, I/O: input or output)

Pin No.	Symbol	I/O	Function Description
1	RSSI	O	External pin connected to bypass capacitor for RSSI reading.
2	BPBG	O	Regulator bias point
3	RFI	I	Low noise amplifier input.
4	RFO	O	Power amplifier output.
5	VDA2	I/O	Voltage supply for RX & TX analog part
6	VT	I	VCO frequency control input, internal connected to PLL charge pump.
7	GND	I	Ground
8	XI	I	Crystal oscillator input node
9	XO	O	Crystal oscillator output node
10	VDA3	I	Voltage supply for PLL part
11	SCS	I	3 wire SPI chip select.
12	SCK	I	3 wire SPI clock input pin.
13	DVDD	I	Supply voltage for digital part.
14	SDIO	I/O	3 wire SPI read/write data pin.
15	GND	I	Ground
16	GIO1	I/O	Multi-function IO 1 / 4-wire SPI data output.
17	GIO2	I/O	Multi-function IO 2 / 4-wire SPI data output.
18	CKO	O	Multi-function clock output.
19	REGI	I	Regulator input
20	VDA1	I/O	Regulator output and voltage supply of IF part

**6. Chip Block Diagram**

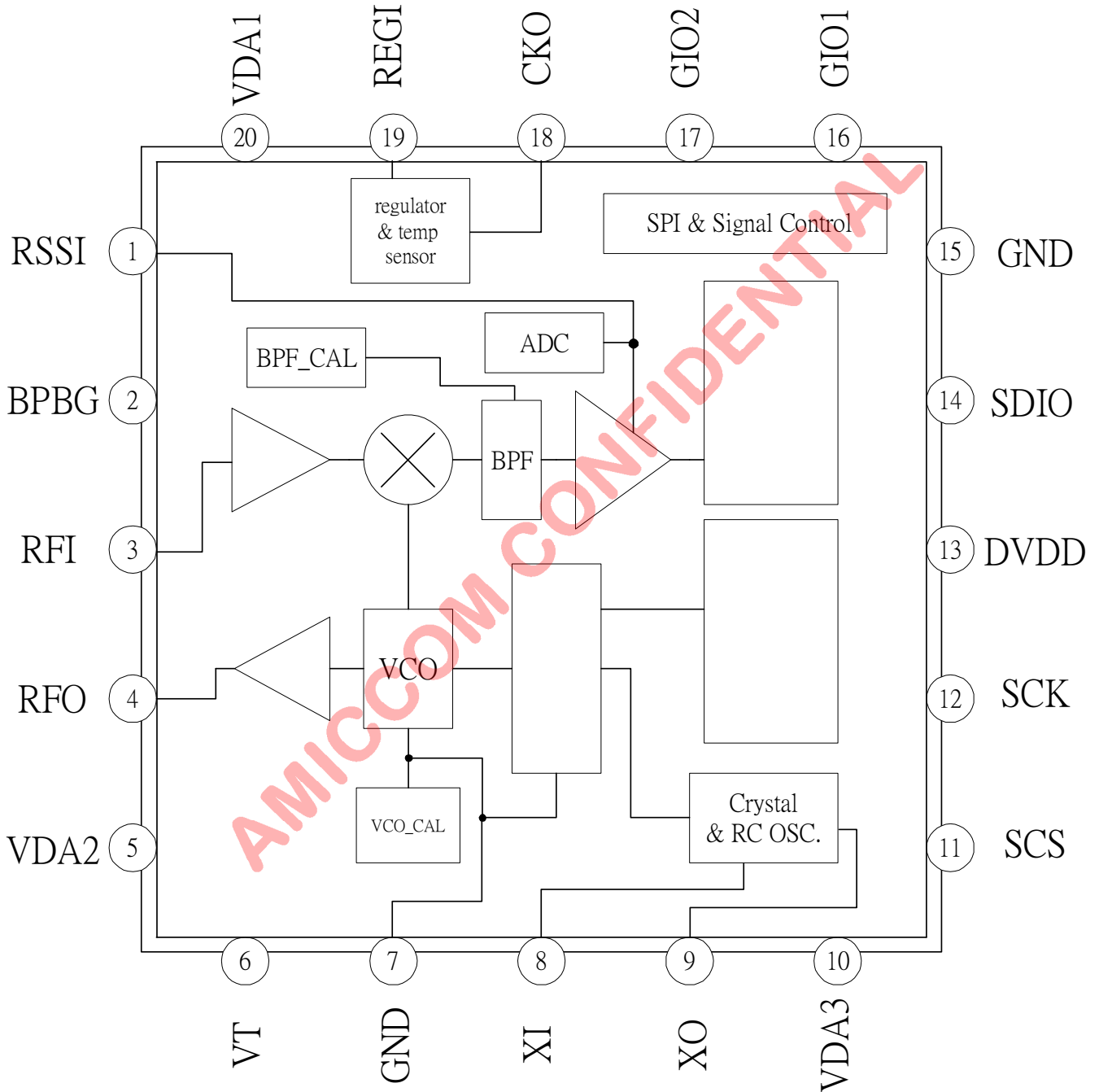

Fig 6-1. System Block Diagram



**7. Absolute Maximum Ratings**

Parameter	With respect to	Rating	Unit
Supply voltage range (VDD)	GND	-0.3 ~ 3.6	V
Digital IO pins range	GND	-0.3 ~ VDD+0.3	V
Maximum input RF level		0	dBm
Storage Temperature range		-55 ~ 125	°C

\*Stresses above those listed under “Absolute Maximum Rating” may cause permanent damage to the device. These are stress ratings only; functional operation of the device at these or any other conditions above those indicated in the operational sections of this specification is not implied. Exposure to absolute-maximum-rated conditions for extended periods may affect device reliability.

**8. Electrical Specification**

(Ta=25°C, VDD = 3.0V, internal regulator voltage = 2.1V, IF bandwidth = 500KHz, unless otherwise noted)

Parameter	Description	Min.	Type	Max.	Unit
<b>General</b>					
Storage Temperature		-55		125	°C
Operating Temperature		-40		85	°C
Supply Voltage (with internal regulator)		1.9		3.6	V
Current Consumption	Sleep mode (RC OSC off)		1.5		µA
	Standby Mode (XOSC on, Clock generator on)* <sup>2</sup>		1.9		mA
	PLL mode		9		mA
	RX Mode		16		mA
	TX Mode (@0dBm output)		19.0		mA
	TX Mode (@-3dBm output)		16		mA
	TX Mode (@-6dBm output)		14.5		mA
TX Mode (@-11dBm output)		13.9		mA	
<b>Synthesizer block</b> (includes crystal oscillator, PLL and VCO.)					
Crystal start up time			0.6		ms
Crystal frequency		6, 8, 12, 16, 20, 24			MHz
Crystal tolerance	without FW FC	±10			ppm
	with FW FC	±20			ppm
VCO Operation Frequency		2400		2483.5	MHz
PLL phase <a href="mailto:noise@loopnoise">mailto:noise@loopnoise</a>	Offset 10k		80		dBc
	Offset 100K		85		
	Offset 1M		90		
PLL settling time (PLL state to WPLL state)	@Loop BW = 500Khz		60		µS
<b>Transmitter</b>					
Output power range		-20	0	1	dBm
hOut Band Spurious Emission * <sup>1</sup>	30MHz~1GHz			-36	dBm
	1GHz~12.75GHz			-30	dBm



	1.8GHz~ 1.9GHz			-47	dBm
	5.15GHz~ 5.3GHz			-47	dBm
Frequency deviation	Data rate > 50Kbps		186K		Hz
	Date rate <=50Kbps		124K		Hz
Data rate		2K		500K	Bps
TX ready time (PLL to WPLL + WPLL to TX)	@Loop BW = 500 KHz, LO frequency fixed		10+60		μS
	@Loop BW = 500 KHz, LO frequency changed		70+60		μS
<b>Receiver</b>					
Receiver sensitivity @ BER = 0.1%	Data rate 500K (F <sub>IF</sub> = 500KHz)			-95	dBm
	Data rate 250K (F <sub>IF</sub> = 500KHz)			-97	dBm
	Data rate 25K (F <sub>IF</sub> = 500KHz)			-104	dBm
	Data rate 2K (F <sub>IF</sub> = 500KHz)			-107	dBm
IF frequency bandwidth			250/500		KHz
IF center frequency			250/500		KHz
Interference	Co-Channel (C/I <sub>0</sub> )			11	dB
	1 <sup>st</sup> Adjacent Channel ( ±1MHz)			20	dBc
	2 <sup>nd</sup> Adjacent Channel ( ±2MHz)			30	dBc
	3 <sup>rd</sup> Adjacent Channel ( > ±5MHz)			40	dBc
	Image (C/I <sub>M</sub> )			12	dBc
Maximum Operating Input Power	@RF input			-20	dBm
Spurious Emission * <sup>1</sup>	30MHz~1GHz			-57	dBm
	1GHz~12.75GHz			-47	
RSSI Range	@RF input		-105	-50	dBm
RX Ready Time (PLL to WPLL + WPLL to RX)	LO frequency fixed	Data rate <= 125 Kbps * <sup>3</sup>		10+40	μs
		Data rate = 250 Kbps * <sup>4</sup>		10+100	μs
		Data rate = 500 Kbps * <sup>4</sup>		10+60	μs
	LO frequency changed	Data rate <= 125 Kbps * <sup>3</sup>		70+40	μs
		Data rate = 250 Kbps * <sup>4</sup>		70+100	μs
		Data rate = 500 Kbps * <sup>4</sup>		70+60	μs
LO leakage at RF port				-55	dBm
<b>Regulator</b>					
Regulator settling time	Pin 2 connected to 1.5 nF			500	μs
Band-gap reference voltage				1.23	V
Regulator output voltage			1.8	2.1	2.3
Line regulation	Load current 30mA		35	40	dBc
<b>Digital IO DC characteristics</b>					
High Level Input Voltage (V <sub>IH</sub> )			0.8*VDD		VDD
Low Level Input Voltage (V <sub>IL</sub> )			0		0.2*VDD
High Level Output Voltage (V <sub>OH</sub> )	@I <sub>OH</sub> = -0.5mA		VDD-0.4		VDD
Low Level Output Voltage (V <sub>OL</sub> )	@I <sub>OL</sub> = 0.5mA		0		0.4

Note 1: With external RF filter that provides minimum 17dB of attenuation in the band: 30MHz ~ 2GHz and 3GHz ~12.75GHz.

Note 2: Internal Clock generator should be turned on before entering PLL, TX and RX mode.

Note 3: DC level of modem is set by Preamble, DCM[1:0]= [01b], register addr. 29h.

Note 4: DC level of modem is set by ID, DCM[1:0]= [10b], register addr. 29h.



**9. Control Register**

A7105 contains 51 x 8-bit control registers. MCU can access those control registers via 3-wire (SCS, SCK, SDIO) or 4-wire (SCS, SCK, SDIO, GIO1/GIO2) SPI interface (support max. SPI data rate up to 10 Mbps). User can refer to chapter 10 for details of SPI timing. A7105 is simply controlled by registers and outputs its status to MCU by GIO1 and GIO2 pins.

**9.1 Control register table**

Address / Name	R/W	Bit 7	Bit 6	Bit 5	Bit 4	Bit 3	Bit 2	Bit 1	Bit 0
00h Mode	W	RESETN	RESETN	RESETN	RESETN	RESETN	RESETN	RESETN	RESETN
	R	-	FECF	CRCF	CER	XER	PLLER	TRSR	TRER
01h Mode control	W	DDPC	ARSSI	AIF	DFCD	WWSE	FMT	FMS	ADCM
	R	DDPC	ARSSI	AIF	CD	WWSE	FMT	FMS	ADCM
02h Calc	R/W	-	-	-	-	-	VCC	VBC	FBC
03h FIFO I	W	FEP7	FEP6	FEP5	FEP4	FEP3	FEP2	FEP1	FEP0
04h FIFO II	W	FPM1	FPM0	PSA5	PSA4	PSA3	PSA2	PSA1	PSA0
05h FIFO Data	R/W	FIFO7	FIFO6	FIFO5	FIFO4	FIFO3	FIFO2	FIFO1	FIFO0
06h ID Data	R/W	ID7	ID6	ID5	ID4	ID3	ID2	ID1	ID0
07h RC OSC I	W	WWS_SL7	WWS_SL6	WWS_SL5	WWS_SL4	WWS_SL3	WWS_SL2	WWS_SL1	WWS_SL0
	R	-	-	RCOC5	RCOC4	RCOC3	RCOC2	RCOC1	RCOC0
08h RC OSC II	W	WWS_SL9	WWS_SL8	WWS_AC5	WWS_AC4	WWS_AC3	WWS_AC2	WWS_AC1	WWS_AC0
09h RC OSC III	W	BBCKS1	BBCKS0	-	-	-	RCOSC_E	TSEL	TWWS_E
0Ah CKO Pin	W	ECKOE	CKOS3	CKOS2	CKOS1	CKOS0	CKOI	CKOE	SCKI
0Bh GPIO1 Pin I	W	-	-	GIO1S3	GIO1S2	GIO1S1	GIO1S0	GIO1I	GIO1OE
0Ch GPIO2 Pin II	W	-	-	GIO2S3	GIO2S2	GIO2S1	GIO2S0	GIO2I	GIO2OE
0Dh Clock	R/W	GRC3	GRC2	GRC1	GRC0	CSC1	CSC0	CGS	XS
0Eh Data rate	R/W	SDR7	SDR6	SDR5	SDR4	SDR3	SDR2	SDR1	SDR0
0Fh PLL I	R/W	CHN7	CHN6	CHN5	CHN4	CHN3	CHN2	CHN1	CHN0
10h PLL II	R/W	DBL	RRC1	RRC0	CHR3	CHR2	CHR1	CHR0	IP8
11h PLL III	R/W	IP7	IP6	IP5	IP4	IP3	IP2	IP1	IP0
12h PLL IV	W	FP15	FP14	FP13	FP12	FP11	FP10	FP9	FP8
	R	-	AC14	AC13	AC12	AC11	AC10	AC9	AC8
13h PLL V	W	FP7	FP6	FP5	FP4	FP3	FP2	FP1	FP0
	R	AC7	AC6	AC5	AC4	AC3	AC2	AC1	AC0
14h TX I	W	TXSM1	TXSM0	TXDI	TME	FS	FDP2	FDP1	FDP0
15h TX II	W	-	PDV1	PDV0	FD4	FD3	FD2	FD1	FD0
16h Delay I	W	DPR2	DPR1	DPR0	TDL1	TDL0	PDL2	PDL1	PDL0



17h Delay II	W	WSEL2	WSEL1	WSEL0	AGC_D1	AGC_D0	RS_DLY2	RS_DLY1	RS_DLY0
18h RX	W	-	RXSM1	RXSM0	FC	RXDI	DMG	BWS	ULS
19h RX Gain I	RW	MVGS	-	IGC	MGC1	MGC0	LGC2	LGC1	LGC0
1Ah RX Gain II	W	RH7	RH6	RH5	RH4	RH3	RH2	RH1	RH0
1Bh RX Gain III	W	RL7	RL6	RL5	RL4	RL3	RL2	RL1	RL0
1Ch RX Gain IV	W	ENGC	-	-	-	MHC	LHC1	LHC0	VGCE
1Dh RSSI Threshold	W	RTH7	RTH6	RTH5	RTH4	RTH3	RTH2	RTH1	RTH0
	R	ADC7	ADC6	ADC5	ADC4	ADC3	ADC2	ADC1	ADC0
1Eh ADC	W	RSM1	RSM0	ERSS	FSARS	-	XADS	RSS	CDM
1Fh Code I	W	-	MCS	WHTS	FECS	CRCS	IDL	PML1	PML0
20h Code II	W	-	DCL2	DCL1	DCL0	ETH1	ETH0	PMD1	PMD0
21h Code III	W	-	WS6	WS5	WS4	WS3	WS2	WS1	WS0
22h IF Calibration I	W	-	-	-	MFBS	MFB3	MFB2	MFB1	MFB0
	R	-	-	-	FBCF	FB3	FB2	FB1	FB0
23h IF Calibration II	R	-	-	-	FCD4	FCD3	FCD2	FCD1	FCD0
24h VCO current Calibration	W	-	-	VCCS	MVCS	VCOC3	VCOC2	VCOC1	VCOC0
	R	-	-	-	FVCC	VCB3	VCB2	VCB1	VCB0
25h VCO Single band Calibration I	W	-	-	-	-	MVBS	MVB2	MVB1	MVB0
	R	-	-	DVT1	DVT0	VBCF	VB2	VB1	VB0
26h VCO Single band Calibration II	W	-	-	VTH2	VTH1	VTH0	VTL2	VTL1	VTL0
27h Battery detect	W	RGS	RGV1	RGV0	-	BVT2	BVT1	BVT0	BDS
	R	RGS	RGV1	RGV0	BDF	BVT2	BVT1	BVT0	BDS
28h TX test	W	-	-	TXCS	PAC1	PAC0	TBG2	TBG1	TBG0
29h Rx DEM test I	W	DMT	DCM1	DCM0	MLP1	MLP0	SLF2	SLF1	SLF0
2Ah Rx DEM test II	W	DCV7	DCV6	DCV5	DCV4	DCV3	DCV2	DCV1	DCV0
2Bh CPC	W	-	-	-	-	-	-	CPC1	CPC0
2Ch Crystal test	W	-	-	-	-	DBD	XCC	XCP1	XCP0
2Dh PLL test	W	-	PMPE	PRRC1	PRRC0	PRIC1	PRIC0	SDPW	NSDO
2Eh VCO test I	W	-	-	-	TLB	TLB	RLB	RLB	VCBS
2Fh VCO test II	W	-	-	-	-	RFT3	RFT2	RFT1	RFT0
30h IFAT	W	IGFI2	IGFI1	IGFI0	IGFQ2	IGFQ1	IGFQ0	IFBC	LIMC

31h RScale	R/W	RSC7	RSC6	RSC5	RSC4	RSC3	RSC2	RSC1	RSC0
32h Filter test	W	FT7	FT6	FT5	FT4	FT3	FT2	FT1	FT0

Legend: - = unimplemented

## 9.2 Control register description

### 9.2.1 Mode Register (Address: 00h)

Name	R/W	Bit 7	Bit 6	Bit 5	Bit 4	Bit 3	Bit 2	Bit 1	Bit 0
Mode	R	--	FECF	CRCF	CER	XER	PLLER	TRSR	TRER
	W	RESETN	RESETN	RESETN	RESETN	RESETN	RESETN	RESETN	RESETN
Reset		--	--	--	--	--	--	--	--

**RESETN:** Write to this register by 0x00 to issue reset command, then it is auto clear

**FECF: FEC flag.**

[0]: FEC pass. [1]: FEC error. (FECF is read only, it is updated internally while receiving every packet.)

**CRCF: CRC flag.**

[0]: CRC pass. [1]: CRC error. (CRCF is read only, it is updated internally while receiving every packet.)

**CER: RF chip enable status.**

[0]: RF chip is disabled. [1]: RF chip is enabled.

**XER: Internal crystal oscillator enabled status.**

[0]: Crystal oscillator is disabled. [1]: Crystal oscillator is enabled.

**PLLE: PLL enabled status.**

[0]: PLL is disabled. [1]: PLL is enabled.

**TRER: TRX state enabled status.**

[0]: TRX is disabled. [1]: TRX is enabled.

**TRSR: TRX Status Register.**

[0]: RX state. [1]: TX state.

Serviceable if TRER=1 (TRX is enable).

### 9.2.2 Mode Control Register (Address: 01h)

Name	R/W	Bit 7	Bit 6	Bit 5	Bit 4	Bit 3	Bit 2	Bit 1	Bit 0
Mode Control I	R	DDPC	ARSSI	AIF	DFCD	WWSE	FMT	FMS	ADCM
	W	DDPC	ARSSI	AIF	CD	WWSE	FMT	FMS	ADCM
Reset		0	0	0	0	0	0	0	0

**DDPC (Direct mode data pin control):** In Direct mode, If DDPC=1, MCU delivers / receives raw data of packet via SDIO pin instead of GIO1 or GIO2 pin.

[0]: Disable. [1]: Enable.

**ARSSI: Auto RSSI measurement while entering RX mode.**

[0]: Disable. [1]: Enable.

**AIF (Auto IF Offset):** RF LO frequency will auto offset one IF frequency while entering RX mode.

[0]: Disable. [1]: Enable.

**CD / DFCD: DFCD (Data Filter by CD):** The received packet will be filtered out if CD is inactive.

[0]: Disable. [1]: Enable.

**CD (Read only): Carrier detector signal.**

[0]: Input power below threshold. [1]: Input power above threshold.

**WWSE: Reserved for internal usage only. Shall be set to [0].**

**FMT: Reserved for internal usage only. Shall be set to [0].**

**FMS: Direct/FIFO mode select.**

[0]: Direct mode. [1]: FIFO mode.

**ADCM: ADC measurement enable (Auto clear when done).**

[0]: Disable measurement or measurement finished. [1]: Enable measurement.

ADCM	A7105 @ Standby mode	A7105 @ RX mode
[0]	Disable ADC	Disable ADC
[1]	No function	Measure RSSI, carrier detect

Refer to chapter 17 for details.

### 9.2.3 Calibration Control Register (Address: 02h)

Name	R/W	Bit 7	Bit 6	Bit 5	Bit 4	Bit 3	Bit 2	Bit 1	Bit 0
Mode Control II	R/W	--	--	--	--	--	VCC	VBC	FBC
Reset		--	--	--	--	--	0	0	0

**VCC: VCO Current calibration enable (Auto clear when done).**

[0]: Disable. [1]: Enable.

**VBC: VCO Bank calibration enable (Auto clear when done).**

[0]: Disable. [1]: Enable.

**FBC: IF Filter Bank calibration enable (Auto clear when done).**

[0]: Disable. [1]: Enable.

### 9.2.4 FIFO Register I (Address: 03h)

Name	R/W	Bit 7	Bit 6	Bit 5	Bit 4	Bit 3	Bit 2	Bit 1	Bit 0
FIFO I	W	FEP7	FEP6	FEP5	FEP4	FEP3	FEP2	FEP1	FEP0
Reset		0	0	1	1	1	1	1	1

**FEP [7:0]: FIFO End Pointer for TX FIFO and Rx FIFO.**

Refer to chapter 16 for details.

### 9.2.5 FIFO Register II (Address: 04h)

Name	R/W	Bit 7	Bit 6	Bit 5	Bit 4	Bit 3	Bit 2	Bit 1	Bit 0
FIFO II	W	FPM1	FPM0	PSA5	PSA4	PSA3	PSA2	PSA1	PSA0
Reset		0	1	0	0	0	0	0	0

**FPM [1:0]: FIFO Pointer Margin**

**PSA [5:0]: Used for Segment FIFO.**

Refer to chapter 16 for details.

### 9.2.6 FIFO DATA Register (Address: 05h)

Name	R/W	Bit 7	Bit 6	Bit 5	Bit 4	Bit 3	Bit 2	Bit 1	Bit 0
FIFO DATA	R/W	FIFO7	FIFO6	FIFO5	FIFO4	FIFO3	FIFO2	FIFO1	FIFO0
Reset		0	0	0	0	0	0	0	0

**FIFO [7:0]: FIFO data. TX FIFO (Write only) and RX FIFO (Read only).**  
 TX FIFO and RX FIFO share the same address (05h).  
 Refer to chapter 16 for details.

**9.2.7 ID DATA Register (Address: 06h)**

Name	R/W	Bit 7	Bit 6	Bit 5	Bit 4	Bit 3	Bit 2	Bit 1	Bit 0
ID DATA	R/W	ID7	ID6	ID5	ID4	ID3	ID2	ID1	ID0
Reset		0	0	0	0	0	0	0	0

**ID [7:0]: ID data.**

**Once this address is accessed, ID Data is input/output in sequence corresponding to Write or Read.**  
 Refer to section 10.6 for details.

**9.2.8 RC OSC Register I (Address: 07h)**

Name	R/W	Bit 7	Bit 6	Bit 5	Bit 4	Bit 3	Bit 2	Bit 1	Bit 0
RC OSC I	R			RCOC5	RCOC4	RCOC3	RCOC2	RCOC1	RCOC0
	W	WWS_SL7	WWS_SL6	WWS_SL5	WWS_SL4	WWS_SL3	WWS_SL2	WWS_SL1	WWS_SL0
Reset		0	0	0	0	0	0	0	0

**RCOC [5:0]: Reserved for internal usage only.**

**9.2.9 RC OSC Register II (Address: 08h)**

Name	R/W	Bit 7	Bit 6	Bit 5	Bit 4	Bit 3	Bit 2	Bit 1	Bit 0
RC OSC II	W	WWS_SL9	WWS_SL8	WWS_AC5	WWS_AC4	WWS_AC3	WWS_AC2	WWS_AC1	WWS_AC0
Reset		0	0	0	0	0	0	0	0

**WWS\_AC [5:0]: Reserved for internal usage only.**

**WWS\_SL [9:0]: Reserved for internal usage only.**

**9.2.10 RC OSC Register III (Address: 09h)**

Name	R/W	Bit 7	Bit 6	Bit 5	Bit 4	Bit 3	Bit 2	Bit 1	Bit 0
RC OSC III	W	BBCKS1	BBCKS0	--	--	--	RCOSC_E	TSEL	TWWS_E
Reset		0	0	--	--	--	1	0	1

**BBCKS [1:0]: Clock select for internal digital block Recommend BBCKS = [00]**  
**[00]:** F<sub>SYCK</sub> / 8. **[01]:** F<sub>SYCK</sub> / 16. **[10]:** F<sub>SYCK</sub> / 32. **[11]:** F<sub>SYCK</sub> / 64.

**RCOSC\_E: RC-oscillator enable.**  
**[0]:** Disable. **[1]:** Enable.

**TSEL: Timer select for TWWS function. Reserved for internal usage only.**  
**[0]:** Use WWS\_AC. **[1]:** Use WWS\_SL.

**TWWS\_E: Enable TWWS function. Reserved for internal usage only.**  
**[0]:** Disable. **[1]:** Enable.

**9.2.11 CKO Pin Control Register (Address: 0Ah)**

Name	R/W	Bit 7	Bit 6	Bit 5	Bit 4	Bit 3	Bit 2	Bit 1	Bit 0
CKO Pin Control	W	ECKOE	CKOS3	CKOS2	CKOS1	CKOS0	CKOI	CKOE	SCKI
Reset		1	0	1	1	1	0	1	0

**ECKOE: External Clock Output Enable for CKOS [3:0]= [0100] ~ [0111].**

[0]: Disable. [1]: Enable.

**CKOS [3:0]: CKO pin output select.**

[0000]: DCK (TX data clock).

[0001]: RCK (RX recovery clock).

[0010]: FPF (FIFO pointer flag).

[0011]: EOP, EOVCB, EOFBC, EOADC, EOVCB, OKADC (Internal usage only).

[0100]: External clock output=  $F_{SYCK}$ .

[0101]: External clock output / 2=  $F_{SYCK} / 2$ .

[0110]: External clock output / 4=  $F_{SYCK} / 4$ .

[0111]: External clock output / 8=  $F_{SYCK} / 8$ .

[1xxx]: Reserved.

**CKOI: CKO pin output signal invert.**

[0]: Non-inverted output. [1]: Inverted output.

**CKOE: CKO pin Output Enable.**

[0]: High Z. [1]: Enable.

**SCKI: SPI clock input invert.**

[0]: Non-inverted input. [1]: Inverted input.

### 9.2.12 GIO1 Pin Control Register I (Address: 0Bh)

Name	R/W	Bit 7	Bit 6	Bit 5	Bit 4	Bit 3	Bit 2	Bit 1	Bit 0
GIO1 Pin Control I	W	--	--	GIO1S3	GIO1S2	GIO1S1	GIO1S0	GIO1I	GIO1OE
Reset		--	--	0	0	0	0	0	1

**GIO1S [3:0]: GIO1 pin function select.**

GIO1S [3:0]	TX state	RX state
[0000]	WTR (Wait until TX or RX finished)	
[0001]	EOAC (end of access code)	FSYNC (frame sync)
[0010]	TME0 (TX modulation enable)	CD (carrier detect)
[0011]	Preamble Detect Output (PMD0)	
[0100]	MCU wakeup signal (TWWS)	
[0101]	In phase demodulator input (DMII)	
[0110]	SDO ( 4 wires SPI data out)	
[0111]	TRXD In/Out (Direct mode)	
[1000]	RXD (Direct mode)	
[1001]	TXD (Direct mode)	
[1010]	In phase demodulator external input (EXDI0)	
[1011]	External FSYNC input in RX direct mode	
[11xx]	Reserved	

**GIO1I: GIO1 pin output signal invert.**

[0]: Non-inverted output. [1]: Inverted output.

**GIO1OE: GIO1 pin output enable.**

[0]: High Z. [1]: Enable.

### 9.2.13 GIO2 Pin Control Register II (Address: 0Ch)

Name	R/W	Bit 7	Bit 6	Bit 5	Bit 4	Bit 3	Bit 2	Bit 1	Bit 0
GIO2 Pin Control II	W	--	--	GIO2S3	GIO2S2	GIO2S1	GIO2S0	GIO2I	GIO2OE
Reset		--	--	0	1	0	0	0	1

**GIO2S [3:0]: GIO2 pin function select.**

GIO2S	TX state	RX state
[0000]	WTR (Wait until TX or RX finished)	
[0001]	EOAC (end of access code)	FSYNC (frame sync)
[0010]	TME0 (TX modulation enable)	CD (carrier detect)
[0011]	Preamble Detect Output (PMD0)	
[0100]	MCU wakeup signal (TWWS)	
[0101]	In phase demodulator input (DMII)	
[0110]	SDO ( 4 wires SPI data out)	
[0111]	TRXD In/Out (Direct mode)	
[1000]	RXD (Direct mode)	
[1001]	TXD (Direct mode)	
[1010]	In phase demodulator external input (EXDI0)	
[1011]	External FSYNC input in RX direct mode	
[11xx]	Reserved	

[0000]	WTR (Wait until TX or RX finished)
[0001]	EOAC (end of access code)   FSYNC (frame sync)
[0010]	TME0 (TX modulation enable)   CD (carrier detect)
[0011]	Preamble Detect Output (PMDO)
[0100]	MCU wakeup signal (TWWS)
[0101]	Quadrature phase demodulator input (DMIQ)
[0110]	SDO (4 wires SPI data out)
[0111]	TRXD In/Out (Direct mode)
[1000]	RXD (Direct mode)
[1001]	TXD (Direct mode)
[1010]	Quadrature phase demodulator external input (EXDI1)
[1011]	External FSYNC input in RX direct mode
[11xx]	Reserved

**GIO2I: GIO2 pin output signal invert.**

[0]: Non-inverted output. [1]: Inverted output.

**GIO2OE: GIO2 pin Output Enable.**

[0]: High Z. [1]: Enable.

#### 9.2.14 Clock Register (Address: 0Dh)

Name	R/W	Bit 7	Bit 6	Bit 5	Bit 4	Bit 3	Bit 2	Bit 1	Bit 0
Clock	R/W	GRC3	GRC2	GRC1	GRC0	CSC1	CSC0	CGS	XS
Reset		1	1	1	1	0	1	0	1

Refer to chapter 14 for details.

**CGS: Clock generator enable.**

[0]: Disable. [1]: Enable.

**XS: Crystal oscillator select. Recommend XC = [1]**

[0]: Use external clock. [1]: Use external crystal.

**F<sub>MCLK</sub> is A7105's master clock to generate F<sub>SYCK</sub>.**

	CGS = 0 (recommend)	CGS = 1
DBL = 0	F <sub>MCLK</sub> = F <sub>XTAL</sub>	F <sub>MCLK</sub> = 32 MHz
DBL = 1 (recommend)	F <sub>MCLK</sub> = 2 * F <sub>XTAL</sub>	F <sub>MCLK</sub> = 32 MHz

**GRC [3:0]: Clock generation reference counter.**

CGS	GRC[3:0]	Note
0	Don't care	
1	F <sub>XTAL</sub> x (DBL+1) / (GRC+1) = 2M	GRC[3:0] is used to generate fixed (2MHz) for Internal 32MHz PLL.

**CSC [1:0]: system clock F<sub>SYCK</sub> divider select.**

CSC [1:0]	Master Clock F <sub>MCLK</sub>		System Clock F <sub>SYCK</sub>	Note
00	CGS = 0	CGS = 1	F <sub>MCLK</sub>	F <sub>SYCK</sub> is used to determine 1. Data rate (0Eh) 2. ADC clock (1Eh) 3. Internal digital clock (09h) 4. CKO pin (0Ah)
01	DBL=0	F <sub>XTAL</sub>	F <sub>MCLK</sub> / 2	
10	DBL=1	2 * F <sub>XTAL</sub>	F <sub>MCLK</sub> / 2	
11			F <sub>MCLK</sub> / 4	



**9.2.15 Data Rate Register (Address: 0Eh)**

Name	R/W	Bit 7	Bit 6	Bit 5	Bit 4	Bit 3	Bit 2	Bit 1	Bit 0
Data Rate	R/W	SDR7	SDR6	SDR5	SDR4	SDR3	SDR2	SDR1	SDR0
Reset		0	0	0	0	0	0	0	0

**SDR [7:0]: Data rate division selection.**

Data rate =  $F_{SYCK} / 32 / (SDR [7:0]+1)$ . Refer to chapter 13 for details.

**9.2.16 PLL Register I (Address: 0Fh)**

Name	R/W	Bit 7	Bit 6	Bit 5	Bit 4	Bit 3	Bit 2	Bit 1	Bit 0
PLL I	R/W	CHN7	CHN6	CHN5	CHN4	CHN3	CHN2	CHN1	CHN0
Reset		0	0	0	0	0	0	0	0

**CHN [7:0]: LO channel number select.**

Refer to chapter 14 for details.

**9.2.17 PLL Register II (Address: 10h)**

Name	R/W	Bit 7	Bit 6	Bit 5	Bit 4	Bit 3	Bit 2	Bit 1	Bit 0
PLL II	R	DBL	RRC1	RRC0	CHR3	CHR2	CHR1	CHR0	IP8
	W	DBL	RRC1	RRC0	CHR3	CHR2	CHR1	CHR0	BIP8
Reset		1	0	0	1	1	1	1	0

**DBL: Crystal frequency doubler selection.**

[0]: Disable.  $F_{XREF} = F_{XTAL}$ . [1]: Enable.  $F_{XREF} = 2 * F_{XTAL}$ .

**RRC [1:0]: RF PLL reference counter setting.**

**CHR [3:0]: PLL channel step setting.**

Refer to chapter 14 for details.

**9.2.18 PLL Register III (Address: 11h)**

Name	R/W	Bit 7	Bit 6	Bit 5	Bit 4	Bit 3	Bit 2	Bit 1	Bit 0
PLL III	R	IP7	IP6	IP5	IP4	IP3	IP2	IP1	IP0
	W	BIP7	BIP6	BIP5	BIP4	BIP3	BIP2	BIP1	BIP0
Reset		0	1	0	0	1	0	1	1

**BIP [8:0]: LO base frequency integer part setting.**

BIP [8:0] are from address (0Fh) and (10h),

**IP [8:0]: LO frequency integer part value.**

IP [8:0] are from address (0Fh) and (10h),

Refer to chapter 14 for details.

**9.2.19 PLL Register IV (Address: 12h)**

Name	R/W	Bit 7	Bit 6	Bit 5	Bit 4	Bit 3	Bit 2	Bit 1	Bit 0
PLL IV	R	--/FP15	AC14/FP14	AC13/FP13	AC12/P12	AC11/FP11	AC10/FP10	AC9/FP9	AC8/FP8
	W	BFP15	BFP14	BFP13	BFP12	BFP11	BFP10	BFP9	BFP8
Reset		0	0	0	0	0	0	0	0

**9.2.20 PLL Register V (Address: 13h)**

Name	R/W	Bit 7	Bit 6	Bit 5	Bit 4	Bit 3	Bit 2	Bit 1	Bit 0
PLL V	R	AC7/FP7	AC6/FP6	AC5/FP5	AC4/FP4	AC3/FP3	AC2/FP2	AC1/FP1	AC0/FP0
	W	BFP7	BFP6	BFP5	BFP4	BFP3	BFP2	BFP1	BFP0
Reset		0	0	0	0	0	0	1	1

**BFP [15:0]: LO base frequency fractional part setting.**

BFP [15:0] are from address (11h) and (12h),

**AC [14:0] (Read): Auto Frequency compensation value (if FC (18h) =1).**

**FP [15:0] (Read): LO frequency fractional part setting.**

Refer to chapter 14 for details.

**9.2.21 TX Register I (Address: 14h)**

Name	R/W	Bit 7	Bit 6	Bit 5	Bit 4	Bit 3	Bit 2	Bit 1	Bit 0
TX I	W	TXSM1	TXSM0	TXDI	TME	FS	FDP2	FDP1	FDP0
Reset		0	0	0	1	0	1	1	0

**TXSM [1:0]: Moving average for non-filter select. Recommend TXSM = [00]**

[00]: not average. [01]: 2 bit average. [10]: 4 bit average. [11]: 8 bit average

**TXDI: TX data invert. Recommend TXDI = [0].**

[0]: Non-invert. [1]: Invert.

**TME: TX modulation enable.**

[0]: Disable. [1]: Enable.

**FS: Filter select.**

Gaussian filter (BT=0.7).

[0]: disable. [1]: enable.

**FDP [2:0]: Frequency deviation power setting. Refer to control register (15h). Recommend FDP = [110].**

**9.2.22 TX Register II (Address: 15h)**

Name	R/W	Bit 7	Bit 6	Bit 5	Bit 4	Bit 3	Bit 2	Bit 1	Bit 0
TX II	W	--	PDV1	PDV0	FD4	FD3	FD2	FD1	FD0
Reset		--	0	0	0	1	0	1	1

**PDV [1:0]: Reserved for internal usage only. Shall be set to [00].**

**FD [4:0]: Frequency deviation setting.**

$$F_{DEV} = F_{PPFD} \times 127 \times (FD [4:0] + 1) \times 2^{(FDP [2:0])} / 2^{24}$$

Where  $F_{PPFD} = F_{XTAL} \times (DBL+1) / (RRC [1:0]+1)$ , PLL comparison frequency.

Data Rate (Kbps)	F <sub>PPFD</sub>	FDP [2:0]	PDV [1:0]	FD[4:0]	Fdev (KHz)
<= 50Kbps	12MHz	110b	01b	10110b (0x16)	122
	16MHz			01111b (0x0F)	124
	24MHz			01010b (0x0A)	127
	32MHz			00111b (0x07)	124
> 50Kbps	16MHz	110b	01b	10111b (0x17)	186
	24MHz			01111b (0x0F)	
	32MHz			01011b (0x0B)	

**9.2.23 Delay Register I (Address: 16h)**

Name	R/W	Bit 7	Bit 6	Bit 5	Bit 4	Bit 3	Bit 2	Bit 1	Bit 0
Delay	W	DPR2	DPR1	DPR0	TDL1	TDL0	PDL2	PDL1	PDL0
Reset		0	0	0	1	0	0	1	0

**DPR [2:0]: Delay scale. Recommend DPR = [000].**

**TDL [1:0]: Delay for TX settling from WPLL to TX.**

Delay= 20 \* (TDL [1:0]+1)\*(DPR [2:0]+1) us.

DPR [2:0]	TDL [1:0]	WPLL to TX	Note
000	00	20 us	
000	01	40 us	
000	10	60 us	<b>Recommend</b>
000	11	80 us	

**PDL [2:0]: Delay for TX settling from PLL to WPLL.**

Delay= 10+20 \* (PDL [2:0]+1)\*(DPR [2:0]+1) us.

DPR [2:0]	PDL [2:0]	PLL to WPLL (LO freq. fixed)	PLL to WPLL (LO freq changed)	Note
000	001	10 us	50 us	
000	010	10 us	70 us	<b>Recommend</b>
000	011	10 us	90 us	
000	100	10 us	110 us	

**9.2.24 Delay Register II (Address: 17h)**

Name	R/W	Bit 7	Bit 6	Bit 5	Bit 4	Bit 3	Bit 2	Bit 1	Bit 0
Delay	W	WSEL2	WSEL1	WSEL0	AGC_D1	AGC_D0	RS_DLY2	RS_DLY1	RS_DLY0
Reset		0	1	0	0	0	0	0	1

**WSEL [2:0]: XTAL settling delay setting (200us ~ 2.5ms). Recommend WSEL = [011].**

[000]: 200us. [001]: 400us. [010]: 800us. [011]: 600us.

[100]: 1ms. [101]: 1.5ms. [110]: 2ms. [111]: 2.5ms.

**AGC\_D [1:0]: AGC delay settling Recommend AGC\_D[1:0] = [00].**

[00]: 10us. [01]: 20us. [10]: 30us. [11]: 40us.

**RS\_DLY [2:0]: RSSI measurement delay (10us ~ 80us). Recommend RS\_DLY = [000].**

[000]: 10us. [001]: 20us. [010]: 30us. [011]: 40us.

[100]: 50us. [101]: 60us. [110]: 70us. [111]: 80us.

**9.2.25 RX Register (Address: 18h)**

Name	R/W	Bit 7	Bit 6	Bit 5	Bit 4	Bit 3	Bit 2	Bit 1	Bit 0
RX	W	--	RXSM1	RXSM0	FC	RXDI	DMG	BWS	ULS
Reset		--	1	0	0	0	0	1	0

**RXSM0: Reserved for internal usage only. Shall be set to [1].**

**RXSM1: Reserved for internal usage only. Shall be set to [1].**

**FC: Frequency compensation select.**

[0]: Disalbe . [1]: Enable.

Refer to section 14.4 for details.

**RXDI: RX data output invert. Recommend RXDI = [0].**

[0]: Non-inverted output. [1]: Inverted output.

**DMG:** Reserved for internal usage only. Shall be set to [0].

**BWS:** BPF bandwidth select. Recommend BWS = [1].

[0]: 250KHz. [1]: 500KHz.

Data Rate (Kbps)	BWS	Note
2~ 500	1	F <sub>IF</sub> = 500KHz

**ULS:** RX Up/Low side band select.

[0]: Up side band, [1]: Low side band.

Refer to section 14.2 for details.

**9.2.26 RX Gain Register I (Address: 19h)**

Name	R/W	Bit 7	Bit 6	Bit 5	Bit 4	Bit 3	Bit 2	Bit 1	Bit 0
RX Gain I	R/W	MVGS	--	IGC	MGC1	MGC0	LGC2	LGC1	LGC0
Reset		0	--	1	0	0	0	0	0

**MVGS:** Manual VGA calibrate. Recommend MVGS = [0].

[0]: Auto. [1]: Manual

**IGC:** Reserved for internal usage only. Shall be set to [0].

**MGS [1:0]:** Mixer gain. Recommend MGS = [00].

[00]: 24dB. [01]: 18dB. [10]: 12dB. [11]: 6dB.

**LGS [2:0]:** LNA gain. Recommend LGS = [000].

[000]: 24dB. [001]: 18dB. [010]: 12dB. [011]: 6dB. [1XX]: 0dB.

**9.2.27 RX Gain Register II (Address: 1Ah)**

Name	R/W	Bit 7	Bit 6	Bit 5	Bit 4	Bit 3	Bit 2	Bit 1	Bit 0
RX Gain II	R/W	RH7	RH6	RH5	RH4	RH3	RH2	RH1	RH0
Reset		0	0	0	0	1	0	1	0

**RH [7:0]:** Reserved for internal usage only.

**9.2.28 RX Gain Register III (Address: 1Bh)**

Name	R/W	Bit 7	Bit 6	Bit 5	Bit 4	Bit 3	Bit 2	Bit 1	Bit 0
RX Gain III	W	RL7	RL6	RL5	RL4	RL3	RL2	RL1	RL0
Reset		1	0	1	1	0	1	0	0

**RL [7:0]:** Reserved for internal usage only.

**9.2.29 RX Gain Register IV (Address: 1Ch)**

Name	R/W	Bit 7	Bit 6	Bit 5	Bit 4	Bit 3	Bit 2	Bit 1	Bit 0
RX Gain III	W	ENG C				MHC	LHC1	LHC0	VGCE
Reset		1				1	1	1	0

**ENG C:** Reserved for internal usage only. Shall be set to [0]

**MHC:** Reserved for internal usage only. Shall be set to [1].

**LHC:** Reserved for internal usage only. Shall be set to [01].

**VGCE:** Reserved for internal usage only. Shall be set to [0]

**9.2.30 RSSI Threshold Register (Address: 1Dh)**

Name	R/W	Bit 7	Bit 6	Bit 5	Bit 4	Bit 3	Bit 2	Bit 1	Bit 0
RSSI Threshold	R	ADC7	ADC6	ADC5	ADC4	ADC3	ADC2	ADC1	ADC0
	W	RTH7	RTH6	RTH5	RTH4	RTH3	RTH2	RTH1	RTH0
Reset		1	0	0	1	0	0	0	1

**RTH [7:0]: Carrier detect threshold.**

Refer to Chapter 17 for details.

**ADC [7:0]: ADC output value for RSSI measurement.**

ADC input voltage= 1.2 \* ADC [7:0] / 256 V.

Refer to chapter 17 for details.

**9.2.31 ADC Control Register (Address: 1Eh)**

Name	R/W	Bit 7	Bit 6	Bit 5	Bit 4	Bit 3	Bit 2	Bit 1	Bit 0
ADC Control	W	RSM1	RSM0	ERSS	FSARS	--	XADS	RSS	CDM
Reset		0	1	0	1	--	0	1	1

**RSM [1:0]: RSSI margin = RTH – RTL. Recommend RSM = [11].**

[00]: 5. [01]: 10. [10]: 15. [11]: 20.

Refer to Chapter 17 for details.

**ERSS: End for RSSI measurement**

[0]: RSSI measurement continues until leave off RX mode.

[1]: RSSI measurement will end when carrier detected and ID code word received.

**FSARS: ADC clock select. Recommend FSARS = [0].**

[0]: 4MHz. [1]: 8MHz.

**XADS: ADC input signal select.**

[0]: Convert RSS signal. [1]: Reserved for internal usage.

**RSS: RSSI measurement select.**

[0]: Reserved for internal usage. [1]: RSSI or carrier-detect measurement.

**CDM: RSSI measurement mode.**

[0]: Single mode. [1]: Continuous mode.

**9.2.32 Code Register I (Address: 1Fh)**

Name	R/W	Bit 7	Bit 6	Bit 5	Bit 4	Bit 3	Bit 2	Bit 1	Bit 0
Code I	W	--	MCS	WHTS	FECS	CRCS	IDL	PML1	PML0
Reset		--	0	0	0	0	1	1	1

**WHTS: Data whitening (Data Encryption) select.**

[0]: Disable. [1]: Enable.

**FECS: FEC select.**

[0]: Disable. [1]: Enable.

**CRCS: CRC select.**

[0]: Disable. [1]: Enable.

**IDL: ID code length select. Recommend IDL= [1].**

[0]: 2 bytes. [1]: 4 bytes.

**PML [1:0]: Preamble length select. Recommend PML= [11].**

[00]: 1 byte. [01]: 2 bytes. [10]: 3 bytes. [11]: 4 bytes.

Refer to chapter 16 for details.

9.2.33 Code Register II (Address: 20h)

Name	R/W	Bit 7	Bit 6	Bit 5	Bit 4	Bit 3	Bit 2	Bit 1	Bit 0
Code II	W	--	DCL2	DCL1	DCL0	ETH1	ETH0	PMD1	PMD0
Reset		--	1	1	1	0	1	1	1

**DCL [2:0]: Demodulator DC estimation average mode. Refer to DCM (2Eh) for details.**

**DCL [2]: payload average mode. Recommend DCL2 = [0]**

[0]: 128 bits average. [1]: 256 bits average.

**DCL [1]: For average and hold mode. Recommend DCL1 = [0]**

[0]: 32 bits average. [1]: 64 bits average.

**DCL [0]: Preamble detection delay. Recommend DCL0 = [1].**

Count from preamble detected signal.

[0]: 4 bits for DCL1=0, 8 bits for DCL1=1. [1]: 8 bits for DCL1=0, 16 bits for DCL1=1.

**ETH [1:0]: ID code error tolerance. Recommend ETH = [01].**

[00]: 0 bit, [01]: 1 bit. [10]: 2 bits. [11]: 3 bits.

**PMD [1:0]: Preamble pattern detection length.**

[00]: 0bit. [01]: 4bits. [10]: 8bits. [11]: 16bits.

Data Rate (Kbps)	PMD[1:0]	Note
2 ~ 125	11	By Preamble, also refer to 29h
250 / 500	10	By ID, also refer to 29h

Refer to chapter 16 for details.

9.2.34 Code Register III (Address: 21h)

Name	R/W	Bit 7	Bit 6	Bit 5	Bit 4	Bit 3	Bit 2	Bit 1	Bit 0
Code III	W	--	WS6	WS5	WS4	WS3	WS2	WS1	WS0
Reset		--	0	1	0	1	0	1	0

**WS [6:0]: Data Whitening seed setting (data encryption key).**

Refer to chapter 16 for details.

9.2.35 IF Calibration Register I (Address: 22h)

Name	R/W	Bit 7	Bit 6	Bit 5	Bit 4	Bit 3	Bit 2	Bit 1	Bit 0
IF Calibration I	R				FBCF	FB3	FB2	FB1	FB0
	W	--	--	--	MFBS	MFB3	MFB2	MFB1	MFB0
Reset		--	--	--	0	0	1	1	0

**MFBS: IF filter calibration value select. Recommend MFBS = [0].**

[0]: Auto calibration value. [1]: Manual calibration value.

**MFB [3:0]: IF filter manual calibration value.**

**FBCF: IF filter auto calibration flag.**

[0]: Pass. [1]: Fail.

**FB [3:0]: IF filter calibration value.**

MFBS= 0: Auto calibration value (AFB),

MFBS= 1: Manual calibration value (MFB).

Refer to chapter 15 for details.

9.2.36 IF Calibration Register II (Address: 23h)

Name	R/W	Bit 7	Bit 6	Bit 5	Bit 4	Bit 3	Bit 2	Bit 1	Bit 0
------	-----	-------	-------	-------	-------	-------	-------	-------	-------

IF Calibration II	R	--	--		FCD4	FCD3	FCD2	FCD1	FCD0
Reset		--	--	--	--	--	--	--	--

FCD [4:0]: IF filter calibration deviation from goal (Read only).

### 9.2.37 VCO current Calibration Register (Address: 24h)

Name	R/W	Bit 7	Bit 6	Bit 5	Bit 4	Bit 3	Bit 2	Bit 1	Bit 0
VCO current Calibration	R				FVCC	VCB3	VCB2	VCB1	VCB0
	W	--	--	VCCS	MVCS	VCOC3	VCOC2	VCOC1	VCOC0
Reset		--	--	0	0	1	0	0	0

VCCS: Reserved for internal usage only. Shall be set [0].

MVCS: VCO current calibration value select. Recommend MVCS = [0].

[0]: Auto calibration value. [1]: Manual calibration value.

VCOC [3:0]: VCO current manual calibration value.

FVCC: VCO current auto calibration flag.

[0]: Pass. [1]: Fail.

VCB [3:0]: VCO current calibration value.

MVCS= 0: Auto calibration value (VCB).

MVCS= 1: Manual calibration value (VCOC).

Refer to chapter 15 for details.

### 9.2.38 VCO Single band Calibration Register I (Address: 25h)

Name	R/W	Bit 7	Bit 6	Bit 5	Bit 4	Bit 3	Bit 2	Bit 1	Bit 0
VCO Single band Calibration I	R	--	--	DVT1	DVT0	VBCF	VB2	VB1	VB0
	W	--	--	--	--	MVBS	MVB2	MVB1	MVB0
Reset		--	--	--	--	0	1	0	0
Reset		--	--	--	--	0	1	0	0

MVBS: VCO bank calibration value select. Recommend MVBS = [0].

[0]: Auto calibration value. [1]: Manual calibration value.

MVB [2:0]: VCO band manual calibration value.

DVT [1:0]: digital VCO tuning voltage output.

[00]:  $V_T < V_{TL} < V_{TH}$ . [01]:  $V_{TL} < V_T < V_{TH}$ . [10]: No used. [11]:  $V_{TL} < V_{TH} < V_T$ .

VBCF: VCO band auto calibration flag.

[0]: Pass. [1]: Fail.

VB [2:0]: VCO bank calibration value.

MVBS= 0: Auto calibration value (AVB).

MVBS= 1: Manual calibration value (MVB).

Refer to chapter 15 for details.

### 9.2.39 VCO Single band Calibration Register II (Address: 26h)

Name	R/W	Bit 7	Bit 6	Bit 5	Bit 4	Bit 3	Bit 2	Bit 1	Bit 0
VCO Single band Calibration II	W	--	--	VTH2	VTH1	VTH0	VTL2	VTL1	VTL0
Reset		--	--	1	1	1	0	1	1

VTH [2:0]: VCO tuning voltage upper threshold level setting

[000]:  $V_{DD\_A} - 0.6V$ . [001]:  $V_{DD\_A} - 0.7V$ . [010]:  $V_{DD\_A} - 0.8V$ . [011]:  $V_{DD\_A} - 0.9V$

[100]: VDD\_A – 1.0V. [101]: VDD\_A – 1.1V. [110]: VDD\_A – 1.2V. [111]: VDD\_A – 1.3V

VDD\_A is on chip analog regulator output voltage

**VTL [2:0]: VCO tuning voltage lower threshold level setting**

[000]: 0.1V. [001]: 0.2V. [010]: 0.3V. [011]: 0.4V.

[100]: 0.5V. [101]: 0.6V. [110]: 0.7V. [111]: 0.8V

#### 9.2.40 Battery detect Register (Address: 27h)

Name	R/W	Bit 7	Bit 6	Bit 5	Bit 4	Bit 3	Bit 2	Bit 1	Bit 0
Battery detect	R	--	--	--	BDF	--	--	--	--
	W	RGS	RGV1	RGV0	--	BVT2	BVT1	BVT0	BDS
Reset		0	0	0	--	0	1	1	0

**RGS: VDD\_D voltage setting in Sleep mode.**

[0]:  $3/5 * REG1$ . [1]:  $3/4 * REG1$ .

**RGV [1:0]: VDD\_D and VDD\_A voltage setting in non-Sleep mode. Recommend RGV = [00].**

[00]: 2.1V. [01]: 2.0V. [10]: 1.9V. [11]: 1.8V.

**BVT [2:0]: Battery voltage detect threshold.**

[000]: 2.0V. [001]: 2.1V. [010]: 2.2V. [011]: 2.3V.

[100]: 2.4V. [101]: 2.5V. [110]: 2.6V. [111]: 2.7V.

**BDS: Battery detect select.**

[0]: Disable. [1]: Enable. It will be clear after battery detection done.

**BDF: Battery detection flag.**

[0]: Battery voltage less than threshold. [1]: Battery voltage greater than threshold.

Refer to chapter 18 for details.

#### 9.2.41 TX test Register (Address: 28h)

Name	R/W	Bit 7	Bit 6	Bit 5	Bit 4	Bit 3	Bit 2	Bit 1	Bit 0
TX test	W	--	--	TXCS	PAC1	PAC0	TBG2	TBG1	TBG0
Reset		--	--	0	1	0	1	1	1

**TXCS: TX Current Setting.**

**PAC [1:0]: PA Current Setting.**

**TBG [2:0]: TX Buffer Setting.**

Refer to chapter 19 for details.

#### 9.2.42 Rx DEM test Register I (Address: 29h)

Name	R/W	Bit 7	Bit 6	Bit 5	Bit 4	Bit 3	Bit 2	Bit 1	Bit 0
Rx DEM test I	W	DMT	DCM1	DCM0	MLP1	MLP0	SLF2	SLF1	SLF0
Reset		0	1	1	0	0	1	0	0

**DMT: Reserved for internal usage only. Shall be set to [0].**

**DCM [1:0]: Demodulator DC estimation mode.**

[00]: Fix mode (For testing only). DC level is set by DCV [7:0].

[01]: Preamble hold mode. DC level is preamble average value.

[10]: Average and hold mode. DC level is the average value hold about 8 bit data rate later if preamble is detected.

[11]: Payload average mode (For internal usage). DC level is payload data average.

Data Rate (Kbps)	DCM [1:0]	DCL[2:0] (20h)	Note
2 ~ 125	01	001	By Preamble
250 / 500	10	001	By ID



MLP [1:0]: Reserved for internal usage only. Shall be set to [00].

SLF [2:0]: Reserved for internal usage only. Shall be set to [111].

**9.2.43 Rx DEM test Register II (Address: 2Ah)**

Name	R/W	Bit 7	Bit 6	Bit 5	Bit 4	Bit 3	Bit 2	Bit 1	Bit 0
Rx DEM test II	W	DCV7	DCV6	DCV5	DCV4	DCV3	DCV2	DCV1	DCV0
Reset		1	0	0	0	0	0	0	0

DCV [7:0]: Demodulator fix mode DC value. Recommend DCV = [0x80].

**9.2.44 Charge Pump Current Register (Address: 2Bh)**

Name	R/W	Bit 7	Bit 6	Bit 5	Bit 4	Bit 3	Bit 2	Bit 1	Bit 0
Charge Pump Current	W	--	--	--	--	--	--	CPC1	CPC0
Reset		--	--	--	--	--	--	0	1

CPC [1:0]: Charge pump current setting. Recommend CPC = [11].  
 [00]: 0.5mA. [01]: 1.0mA. [10]: 1.5mA. [11]: 2.0mA

**9.2.45 Crystal test Register (Address: 2Ch)**

Name	R/W	Bit 7	Bit 6	Bit 5	Bit 4	Bit 3	Bit 2	Bit 1	Bit 0
Crystal test	W	--	--	--	--	DBD	XCC	XCP1	XCP0
Reset		--	--	--	--	0	1	0	1

DBD: Reserved for internal usage only. Shall be set to [0].

XCC: Reserved for internal usage only. Shall be set to [0].

XCP [1:0]: Reserved for internal usage only. Shall be set to [01].

**9.2.46 PLL test Register (Address: 2Dh)**

Name	R/W	Bit 7	Bit 6	Bit 5	Bit 4	Bit 3	Bit 2	Bit 1	Bit 0
PLL test	W	--	PMPE	PRRC1	PRRC0	PRIC1	PRIC0	SDPW	NSDO
Reset		--	1	1	0	1	0	0	0

PMPE: Reserved for internal usage only. Shall be set to [1].

PRRC [1:0]: Reserved for internal usage only. Shall be set to [00].

PRIC [1:0]: Reserved for internal usage only. Shall be set to [01].

SDPW: Reserved for internal usage only. Shall be set to [0].

NSDO: Reserved for internal usage only. Shall be set to [1].

**9.2.47 VCO test Register I (Address: 2Eh)**

Name	R/W	Bit 7	Bit 6	Bit 5	Bit 4	Bit 3	Bit 2	Bit 1	Bit 0
VCO test I	W	--	--	--	TLB1	TLB0	RLB1	RLB0	VCBS
Reset		--	--	--	1	1	0	1	0

TLB [1:0]: Reserved for internal usage only. Shall be set to [11].

RLB [1:0]: Reserved for internal usage only. Shall be set to [00].

VCBS: Reserved for internal usage only. Shall be set to [0].

**9.2.48 VCO test Register II (Address: 2Fh)**

Name	R/W	Bit 7	Bit 6	Bit 5	Bit 4	Bit 3	Bit 2	Bit 1	Bit 0
VCO test II	W	--	--	--	--	RFT3	RFT2	RFT1	RFT0
Reset		--	--	--	--	0	0	0	0

RFT [3:0]: RF analog pin configuration for testing. Recommend RFT= [0000].

**9.2.49 IFAT Register (Address: 30h)**

Name	R/W	Bit 7	Bit 6	Bit 5	Bit 4	Bit 3	Bit 2	Bit 1	Bit 0
VCO test II	W	IGFI2	IGFI1	IGFI0	IGFQ2	IGFQ1	IGFQ0	IFBC	LIMC
Reset		1	0	0	1	0	0	1	1

IGFI [2:0]: Reserved for internal usage only. Shall be set to [000].

IGFQ [2:0]: Reserved for internal usage only. Shall be set to [000].

IFBC: Reserved for internal usage only. Shall be set to [0].

LIMC: Reserved for internal usage only. Shall be set to [1].

**9.2.50 RScale Register (Address: 31h)**

Name	R/W	Bit 7	Bit 6	Bit 5	Bit 4	Bit 3	Bit 2	Bit 1	Bit 0
Rscale	W	RSC7	RSC6	RSC5	RSC4	RSC3	RSC2	RSC1	RSC0
Reset		0	0	0	0	1	1	1	1

RSC [7:0]: Reserved for internal usage only. Shall be set to = [0x0F].

**9.2.51 Filter test Register (Address: 32h)**

Name	R/W	Bit 7	Bit 6	Bit 5	Bit 4	Bit 3	Bit 2	Bit 1	Bit 0
Filter test	W	FT7	FT6	FT5	FT4	FT3	FT2	FT1	FT0
Reset									

FT [7:0]: Reserved for internal usage only. Shall be set to = [0x00].

### 10. SPI

A7105 only supports one SPI interface with maximum data rate up to 10Mbps. MCU should assert SCS pin low (SPI chip select) to active accessing of A7105. Via SPI interface, user can access **control registers** and issue **Strobe command**. Figure 10.1 gives an overview of SPI access manners.

3-wire SPI (SCS, SCK and SDIO) or 4-wire SPI (SCS, SCK, SDIO and GIO1/GIO2) configuration is provided. For 3-wire SPI, SDIO pin is configured as bi-direction to be data input and output. For 4-wire SPI, SDIO pin is data input and GIO1 (or GIO2) pin is data output. In such case, GIO1S (0bh) or GIO2S (0ch) should be set to [0110].

For SPI write operation, SDIO pin is latched into A7105 at the rising edge of SCK. For SPI read operation, if input address is latched by A7105, data output is aligned at falling edge of SCK. Therefore, MCU can latch data output at the rising edge of SCK.

To control A7105's internal state machine, it is very easy to send Strobe command via SPI interface. The Strobe command is a unique command set with total 8 commands. See section 10.3, 10.4 and 10.5 for details.

	SPI chip select	Data In	Data Out
<b>3-Wire SPI</b>	SCS pin = 0	SDIO pin	SDIO pin
<b>4-Wire SPI</b>	SCS pin = 0	SDIO pin	GIO1 (GIO1S=0110) / GIO2 (GIO2S=0110)



Figure 10.1 SPI Access Manners

**10.1 SPI Format**

The first bit (A7) is critical to indicate A7105 the following instruction is “Strobe command” or “control register”. See Table 10.1 for SPI format. Based on Table 10.1, To access control registers, just set A7=0, then A6 bit is used to indicate read (A6=1) or write operation (A6=0). See Figure 10.2 (3-wire SPI) and Figure 10.3 (4-wire SPI) for details.

Address Byte (8 bits)								Data Byte (8 bits)							
CMD	R/W	Address						Data							
A7	A6	A5	A4	A3	A2	A1	A0	7	6	5	4	3	2	1	0

Table 10.1 SPI Format

**Address byte:**

**Bit 7: Command bit**

- [0]: Control registers.
- [1]: Strobe command.

**Bit 6: R/W bit**

- [0]: Write data to control register.
- [1]: Read data from control register.

**Bit [5:0]: Address of control register**

**Data Byte:**

**Bit [7:0]:** SPI input or output data, see Figure 10.2 and Figure 10.3 for details.

**10.2 SPI Timing Characteristic**

No matter 3-wire or 4-wire SPI interface is configured, the maximum SPI data rate is 10 Mbps. To active SPI interface, SCS pin must be set to low. For correct data latching, user has to take care hold time and setup time between SCK and SDIO. See Table 10.2 for SPI timing characteristic.

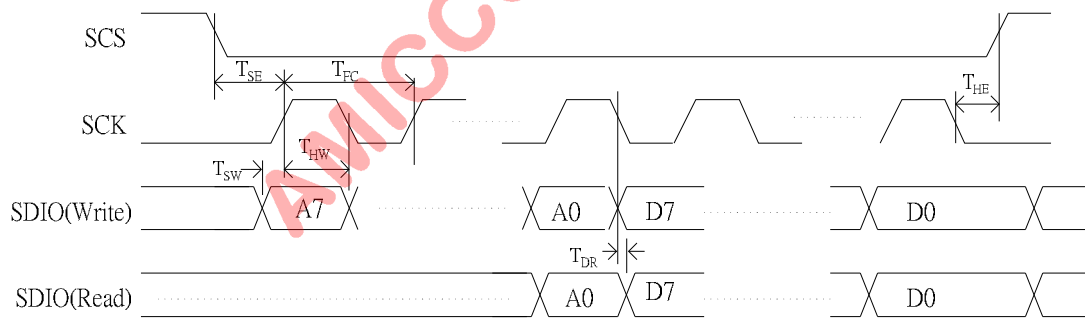

Parameter	Description	Min.	Max.	Unit
F <sub>C</sub>	FIFO clock frequency.		10	MHz
T <sub>SE</sub>	Enable setup time.	50		ns
T <sub>HE</sub>	Enable hold time.	50		ns
T <sub>SW</sub>	TX Data setup time.	50		ns
T <sub>HW</sub>	TX Data hold time.	50		ns
T <sub>DR</sub>	RX Data delay time.	0	50	ns

Table 10.2 SPI Timing Characteristic

**10.3 SPI Timing Chart**

In this section, 3-wire and 4-wire SPI interface read / write timing are described.

**10.3.1 Timing Chart of 3-wire SPI**

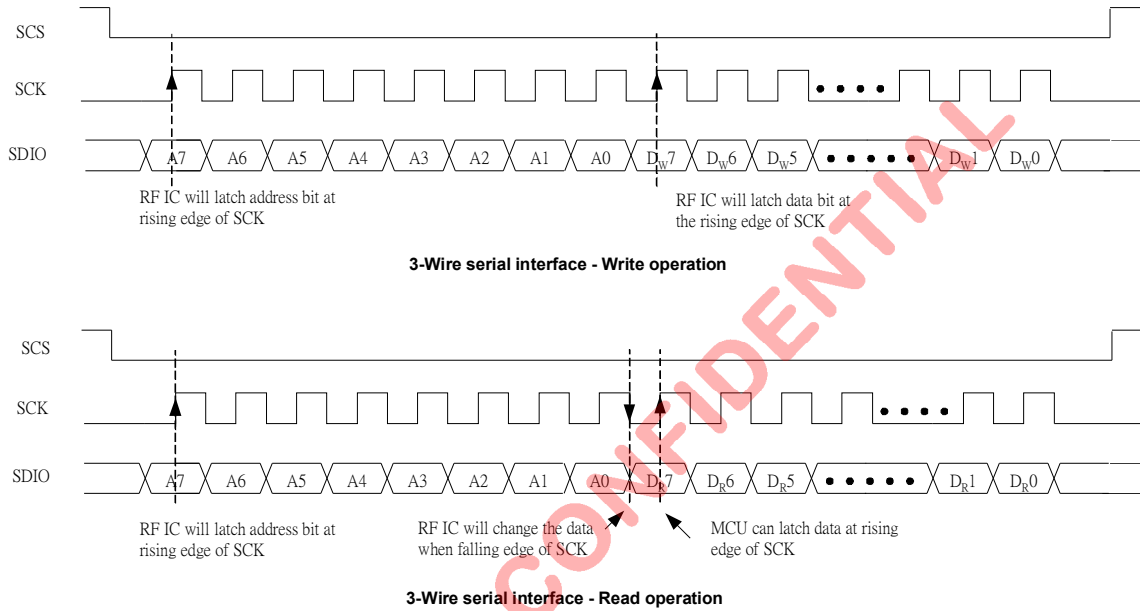

Figure 10.2 Read/Write Timing Chart of 3-Wire SPI

**10.3.2 Timing Chart of 4-wire SPI**

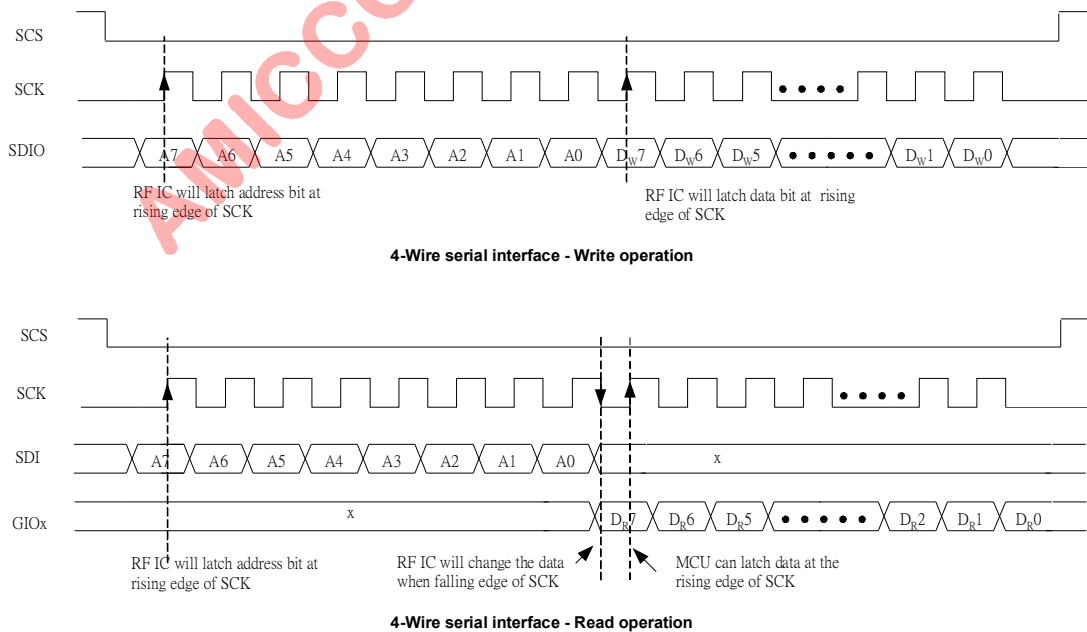

Figure 10.3 Read/Write Timing Chart of 4-Wire SPI

**10.4 Strobe Commands**

A7105 supports 8 Strobe commands to control internal state machine for chip's operations. Table 10.3 is the summary of Strobe commands.

Be notice, Strobe command could be defined by 4-bits (A7~A4) or 8-bits (A7~A0). If 8-bits Strobe command is selected, A3 ~ A0 are don't care conditions. In such case, SCS pin can be remaining low for asserting next commands.

**Strobe Command**

Strobe Command								Description
A7	A6	A5	A4	A3	A2	A1	A0	
1	0	0	0	x	X	x	x	Sleep mode
1	0	0	1	x	X	x	x	Idle mode
1	0	1	0	x	X	x	x	Standby mode
1	0	1	1	x	X	x	x	PLL mode
1	1	0	0	x	X	x	x	RX mode
1	1	0	1	x	X	x	x	TX mode
1	1	1	0	x	X	x	x	FIFO write pointer reset
1	1	1	1	x	X	x	x	FIFO read pointer reset

Table 10.3 Strobe Commands by SPI interface

**10.4.1 Strobe Command - Sleep Mode**

Refer to Table 10.3 user can issue 4 bits (1000) Strobe command directly to set A7105 into Sleep mode. Below are the Strobe command table and timing chart.

**Strobe Command**

Strobe Command								Description
A7	A6	A5	A4	A3	A2	A1	A0	
1	0	0	0	x	X	x	x	Sleep mode

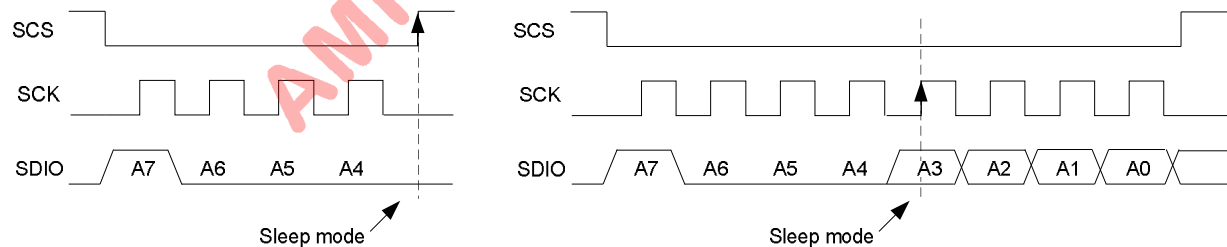

Figure 10.4 Sleep mode Command Timing Chart

**10.4.2 Strobe Command - Idle Mode**

Refer to Table 10.3, user can issue 4 bits (1001) Strobe command directly to set A7105 into Idle mode. Below is the Strobe command table and timing chart.

**Strobe Command**

Strobe Command								Description
A7	A6	A5	A4	A3	A2	A1	A0	
1	0	0	1	x	X	x	x	Idle mode

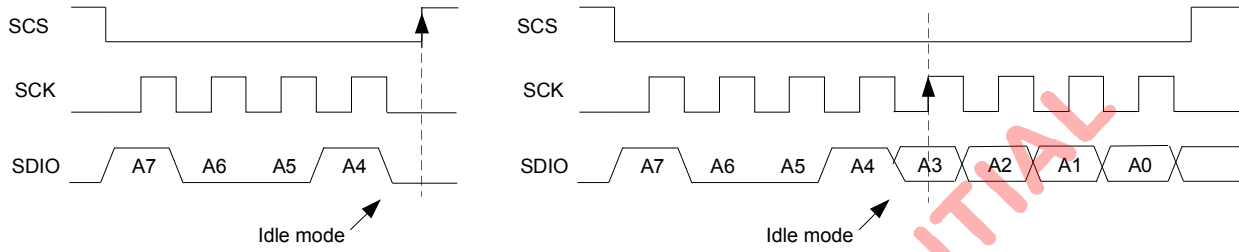

Figure 10.5 Idle mode Command Timing Chart

**10.4.3 Strobe Command - Standby Mode**

Refer to Table 10.3, user can issue 4 bits (1010) Strobe command directly to set A7105 into Standby mode. Below is the Strobe command table and timing chart.

**Strobe Command**

Strobe Command								Description
A7	A6	A5	A4	A3	A2	A1	A0	
1	0	1	0	x	X	x	x	Standby mode

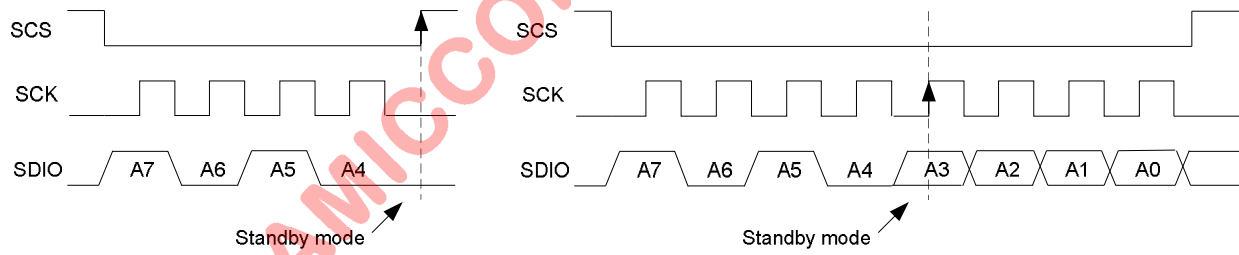

Figure 10.6 Standby mode Command Timing Chart

**10.4.4 Strobe Command - PLL Mode**

Refer to Table 10.3, user can issue 4 bits (1011) Strobe command directly to set A7105 into PLL mode. Below are the Strobe command table and timing chart.

**Strobe Command**

Strobe Command								Description
A7	A6	A5	A4	A3	A2	A1	A0	
1	0	1	1	x	X	x	x	PLL mode

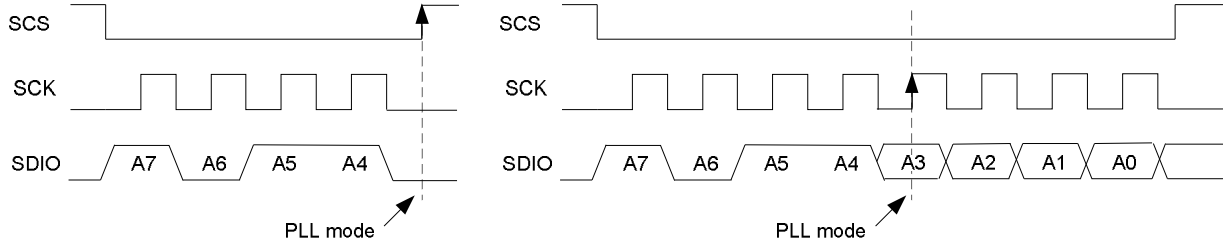

Figure 10.7 PLL mode Command Timing Chart

**10.4.5 Strobe Command - RX Mode**

Refer to Table 10.3, user can issue 4 bits (1100) Strobe command directly to set A7105 into RX mode. Below are the Strobe command table and timing chart.

**Strobe Command**

Strobe Command								Description
A7	A6	A5	A4	A3	A2	A1	A0	
1	1	0	0	x	X	x	x	RX mode

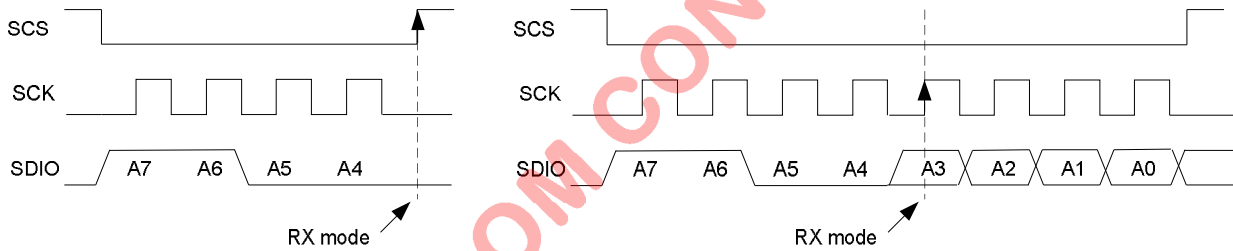

Figure 10.8 RX mode Command Timing Chart

**10.4.6 Strobe Command - TX Mode**

Refer to Table 10.3, user can issue 4 bits (1101) Strobe command directly to set A7105 into TX mode. Below are the Strobe command table and timing chart.

**Strobe Command**

Strobe Command								Description
A7	A6	A5	A4	A3	A2	A1	A0	
1	1	0	1	x	x	x	x	TX mode

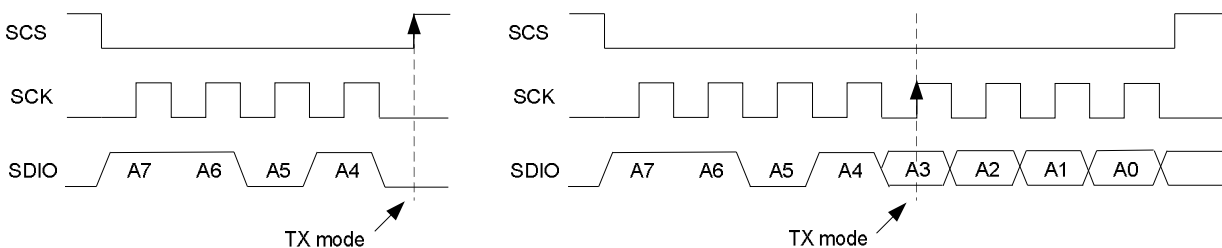

Figure 10.9 TX mode Command Timing Chart



**10.4.7 Strobe Command – FIFO Write Pointer Reset**

Refer to Table 10.3, user can issue 4 bits (1110) Strobe command directly to reset A7105 FIFO write pointer. Below is the Strobe command table and timing chart.

**Strobe Command**

Strobe Command								Description
A7	A6	A5	A4	A3	A2	A1	A0	
1	1	1	0	x	x	x	x	FIFO write pointer reset

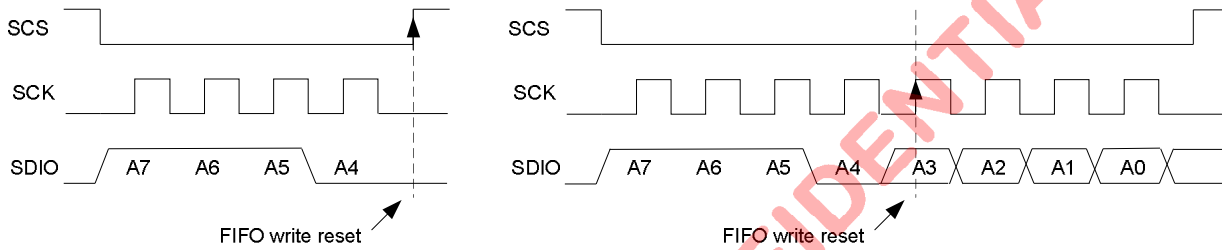

Figure 10.10 FIFO write pointer reset Command Timing Chart

**10.4.8 Strobe Command – FIFO Read Pointer Reset**

Refer to Table 10.3, user can issue 4 bits (1111) Strobe command directly to reset A7105 FIFO read pointer. Below are the Strobe command table and timing chart.

**Strobe Command**

Strobe Command								Description
A7	A6	A5	A4	A3	A2	A1	A0	
1	1	1	1	x	x	x	x	FIFO read pointer reset

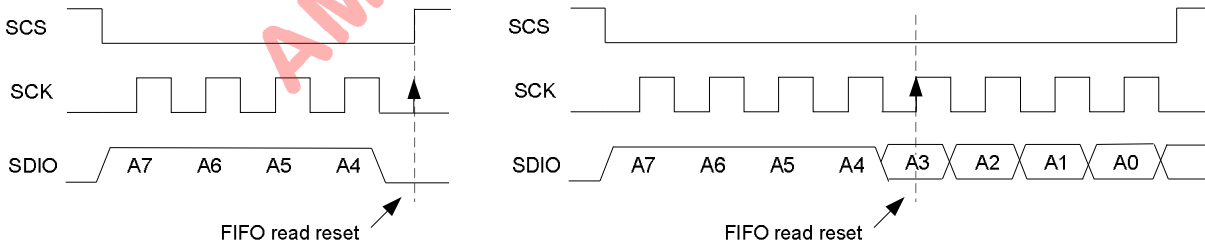

Figure 10.11 FIFO read pointer reset Command Timing Chart

**10.5 Reset Command**

In addition to power on reset (POR), MCU could issue software reset to A7105 by setting Mode Register (00h) through SPI interface as shown below. As long as 8-bits address (A7~A0) are delivered zero and data (D7~D0) are delivered zero, A7105 is informed to generate internal signal “RESETN” to initial itself. After reset command, A7105 is in standby mode and calibration procedure shall be issued again.

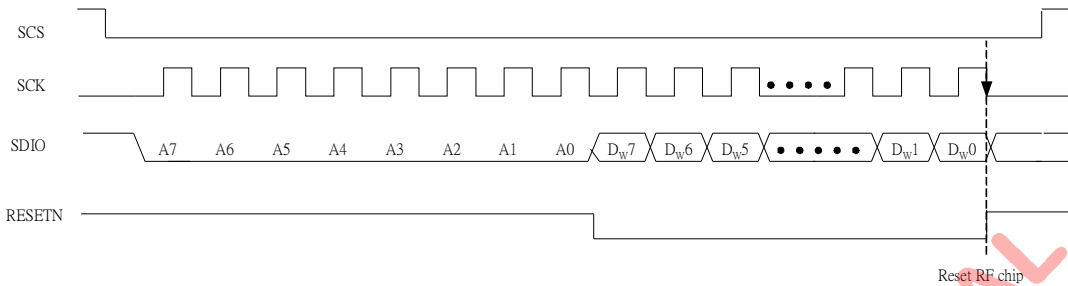

Figure 10.12 Reset Command Timing Chart

**10.6 ID Accessing Command**

A7105 has built-in 32-bits ID Registers for customized identification code. It is accessed via SPI interface. ID length is recommended to be 32 bits by setting IDL (1Fh). Therefore, user can toggle SCS pin to high to terminate ID accessing command when ID data is output completely.

Figure 10.13 and 10.14 are timing charts of 32-bits ID accessing via 3-wire SPI.

**10.6.1 ID Write Command**

User can refer to Figure 10.2 for SPI write timing chart in details. Below is the procedure of ID write command.

- Step1: Deliver A7~A0 = 00000110 (A6=0 for write control register and issue ID addr = 06h).
- Step2: By SDIO pin, deliver 32-bits ID into A7105 in sequence by Data Byte 0, 1, 2 and 3.
- Step3: Toggle SCS pin to high when step2 is completed.

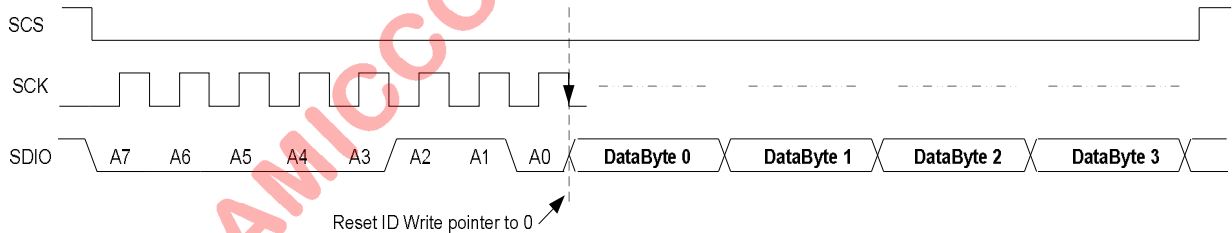

Figure 10.13 ID Write Command Timing Chart

**10.6.2 ID Read Command**

User can refer to Figure 10.2 for SPI read timing chart in details. Below is the procedure of ID read command.

- Step1: Deliver A7~A0 = 01000110 (A6=1 for read control register and issue ID addr. = 06h).
- Step2: SDIO pin outputs 32-bits ID in sequence by Data Byte 0, 1, 2 and 3.
- Step3: Toggle SCS pin to high when step2 is completed.

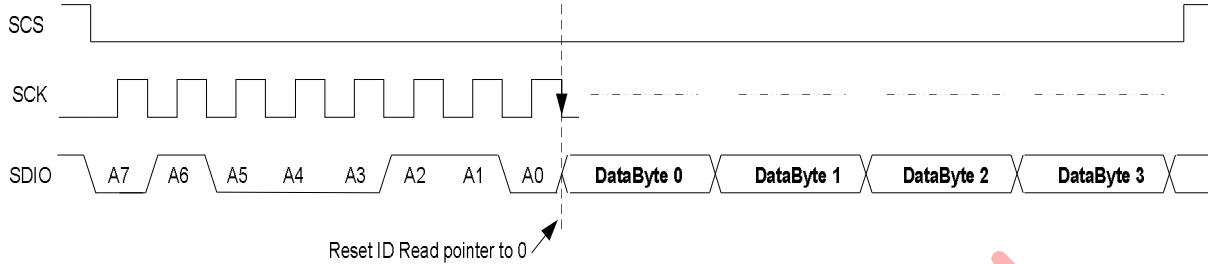

Figure 10.14 ID Read Command Timing Chart

**10.7 FIFO Accessing Command**

To use A7105's FIFO mode, enable FMS (01h) =1 via SPI interface. Before TX delivery, just write wanted data into TX FIFO (05h) then issue TX Strobe command. Similarly, user can read RX FIFO (05h) once payload data is received.

MCU can use polling or interrupt scheme to do FIFO accessing. FIFO status can output to GIO1 (or GIO2) pin by setting GIO1S (0Bh) or GIO2S (0Ch).

Figure 10.15 and 10.16 are timing charts of FIFO accessing via 3-wire SPI.

**10.7.1 TX FIFO Write Command**

User can refer to Figure 10.2 for SPI write timing chart in details. Below is the procedure of TX FIFO write command.

- Step1: Deliver A7~A0 = 00000101 (A6=0 for write control register and issue FIFO A [5:0] = 05h).
- Step2: By SDIO pin, deliver (n+1) bytes TX data into TX FIFO in sequence by Data Byte 0, 1, 2 to n.
- Step3: Toggle SCS pin to high when step2 is completed.
- Step4: Send Strobe command of TX mode (Figure 10.9) to do TX delivery.

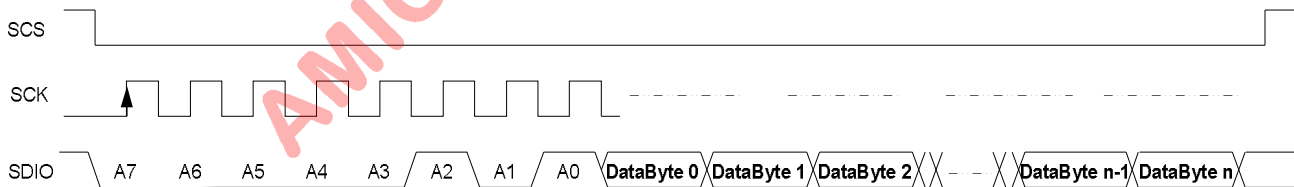

Figure 10.15 TX FIFO Write Command Timing Chart

**10.7.2 Rx FIFO Read Command**

User can refer to Figure 10.2 for SPI read timing chart in details. Below is the procedure of RX FIFO read command.

- Step1: Deliver A7~A0 = 01000101 (A6=1 for read control register and issue FIFO at address 05h).
- Step2: SDIO pin outputs RX data from RX FIFO in sequence by Data Byte 0, 1, 2 to n.
- Step3: Toggle SCS pin to high when RX FIFO is read completely.

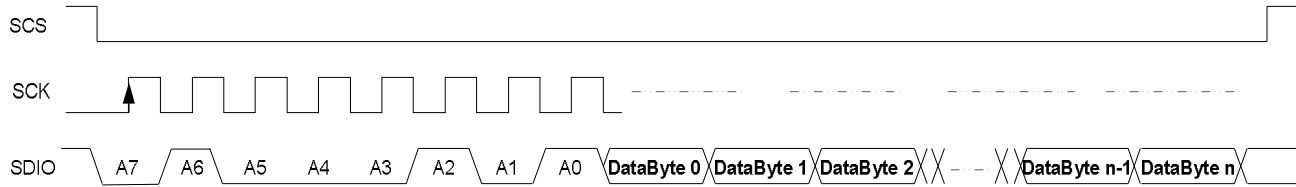

Figure 10.16 RX FIFO Read Command Timing Chart

### 11. State machine

In chapter 9 and chapter 10, user can not only learn A7105's control registers but also know how to issue Strobe command. From section 10.2 ~ 10.6, it is clear to know configurations of 3-wire SPI and 4-wire SPI, Strobe command, software reset, and how to access ID Registers as well as TX/RX FIFO.

Section 11.1 introduces 7 states of built-in state machine. Combined with Strobe command and accessing control registers, section 11.2, 11.3 and 11.4 demonstrate 3 state diagrams to explain how transitions of A7105's operation.

From accessing data point of view, if FMS=1 (01h), FIFO mode is enabled, otherwise, A7105 is in direct mode. If FMS=1 and FIFO Read/Write in Standby mode, we call it is Normal FIFO mode. Otherwise, If FMS=1 and FIFO Read/Write in PLL mode, we called it is Quick FIFO mode due to the time reduction of PLL settling. If FMS=1 and FIFO Read/Write in IDLE mode, we called it is Power Saving FIFO mode due to the reduction of average current.

	SPI chip select	Data In	Data Out	Operation Mode	Clock Recovery for Direct Mode
<b>3-Wire SPI</b>	SCS pin = 0	SDIO pin	SDIO pin	FIFO (FMS=1) Direct (FMS=0)	CKO pin (CKOS = 0001)
<b>4-Wire SPI</b>	SCS pin = 0	SDIO pin	GIO1 (GIO1S=0110) / GIO2 (GIO2S=0110)	FIFO (FMS=1) Direct (FMS=0)	CKO pin (CKOS = 0001)

- (1) Normal FIFO Mode (FMS=1 and FIFO RW @ Standby mode)
- (2) Quick FIFO Mode (FMS=1 and FIFO RW @ PLL mode)
- (3) Power Saving FIFO Mode (FMS=1 and FIFO RW @ IDLE mode)
- (4) Quick Direct Mode (FMS=0 and FIFO ignored, write packet @ TX mode, read packet @ RX mode)

#### 11.1 Key states

A7105 supports 7 key operation states. Those are,

- (1) Standby mode
- (2) Sleep mode
- (3) Idle mode
- (4) PLL mode
- (5) TX mode
- (6) RX mode
- (7) CAL mode

After power on reset or software reset, A7105 is in standby mode. User has to do calibration process because all control registers are in initial values. The calibration process is very easy, user only needs to issue Strobe commands and enable calibration registers. Then, check the calibration flag because it is done automatic by internal state machine. Refer to 11.2, 11.3, 11.4 and chapter 15 for details. After calibration, A7105 is ready to do TX and RX operation.

**11.1.1 Standby mode**

If Standby Strobe command is issued, A7105 enters standby mode automatically. Internal power management is listed below. Be notice, A7105 is in standby mode once power on reset or software reset occurs.

Standby mode						Strobe Command
On Chip Regulator	Crystal Oscillator	VCO	PLL	RX Circuitry	TX Circuitry	
ON	ON	OFF	OFF	OFF	OFF	1010xxxxb See Figure 10.6

**11.1.2 Sleep mode**

If Sleep Strobe command is issued, A7105 enters sleep mode automatically. In sleep mode, A7105 still can accept MCU's commands via SPI interface. But, NOT support to Read/Write FIFO. Internal power management is listed below.

Sleep mode						Strobe Command
On Chip Regulator	Crystal Oscillator	VCO	PLL	RX Circuitry	TX Circuitry	
OFF	OFF	OFF	OFF	OFF	OFF	1000xxxxb See Figure 10.4

**11.1.3 Idle mode**

If Idle Strobe command is issued, A7105 enters idle mode automatically. In idle mode, A7105 can accept MCU's commands via SPI interface as well as supporting Read/Write FIFO. Internal power management is listed below.

Idle mode						Strobe Command
On Chip Regulator	Crystal Oscillator	VCO	PLL	RX Circuitry	TX Circuitry	
ON	OFF	OFF	OFF	OFF	OFF	1001xxxxb See Figure 10.5

**11.1.4 PLL mode**

If PLL Strobe command is issued, A7105 enters PLL mode automatically. In PLL mode, internal PLL and VCO are both turned on to generate LO (local oscillator) frequency before TX and RX operation. Internal power management is listed below. According to PLL Register I, II, III, IV and V, PLL circuitry is easy to be controlled by user's definition.

PLL mode						Strobe Command
On Chip Regulator	Crystal Oscillator	VCO	PLL	RX Circuitry	TX Circuitry	
ON	ON	ON	ON	OFF	OFF	1011xxxxb See Figure 10.7

**11.1.5 TX mode**

If TX Strobe command is issued, A7105 enters TX mode automatically for data delivery. Internal power management is listed below.

(1) In FIFO mode, once TX data packet (Preamble + ID + Payload) is delivered, A7105 supports auto-back function to previous state for next delivered packet.

(2) In Direct mode, once TX data packet is delivered, A7105 stays in TX mode. User has to issue Strobe command to back to previous state.

TX mode						Strobe Command
On Chip Regulator	Crystal Oscillator	VCO	PLL	RX Circuitry	TX Circuitry	
ON	ON	ON	ON	OFF	ON	(1101xxxx)b See Figure 10.9

**11.1.6 RX mode**

If RX Strobe command is issued, A7105 enters RX mode automatically for data receiving. Internal power management is listed below.

(1) In FIFO mode, once RX data packet (Preamble + ID + Payload) is received completely, A7105 supports auto-back function to previous state for next receiving packet.

(2) In Direct mode, once RX data packet is received, A7105 stays in RX mode. User has to issue Strobe command to back to previous state.

RX mode						Strobe Command
On Chip Regulator	Crystal Oscillator	VCO	PLL	RX Circuitry	TX Circuitry	
ON	ON	ON	ON	ON	OFF	(1101xxxx)b See Figure 10.9

**11.1.7 CAL mode**

Calibration process shall be done after power on reset or software reset. Calibration items include VCO and IF Filter. It is easy to implement calibration process by Strobe command and enable CALC (02h) control register. See chapter 15 for details.

Be notice, VCO Calibration is only executable in PLL mode. However, IF Filter Calibration can be executed in Standby or PLL mode.

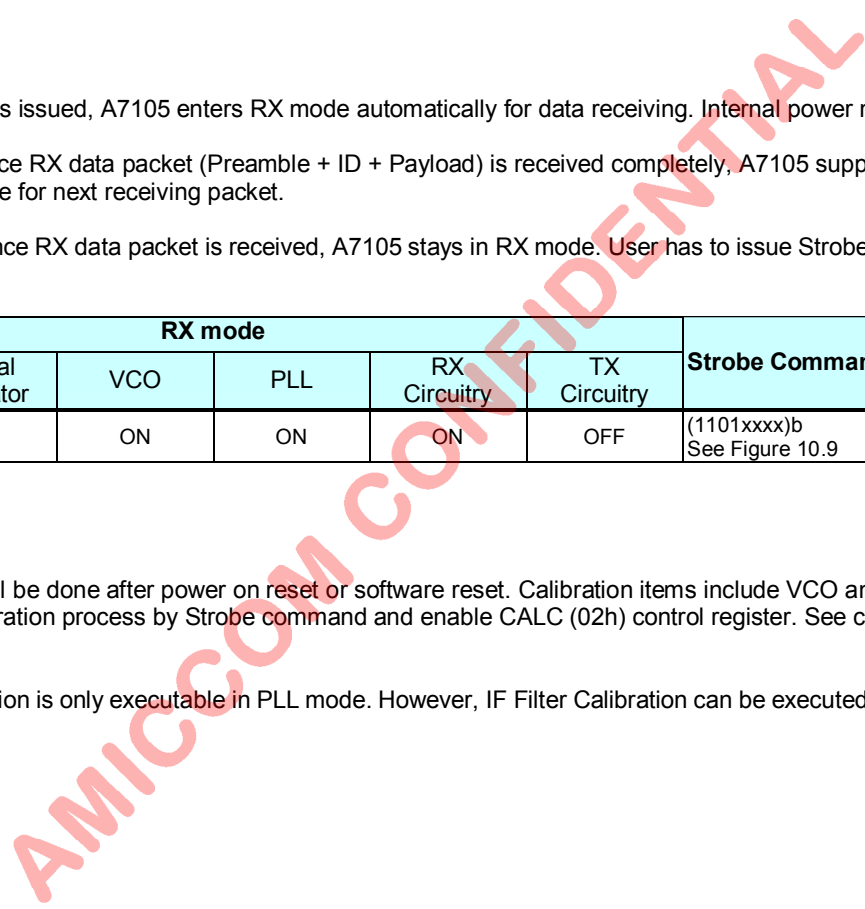

**11.2 Normal FIFO Mode**

This mode is suitable for requirement of general purpose applications. After calibration flow, user can issue Strobe command to enter standby mode where write TX FIFO or read RX FIFO. From standby mode to packet transmission, only one Strobe command is needed. Once transmission is done, A7105 is auto back to standby mode. If all packets are finished and deeper power saving is necessary, user can issue Strobe command to ask A7105 staying in sleep mode. Figure 11.1 is the state diagram of Normal FIFO mode.

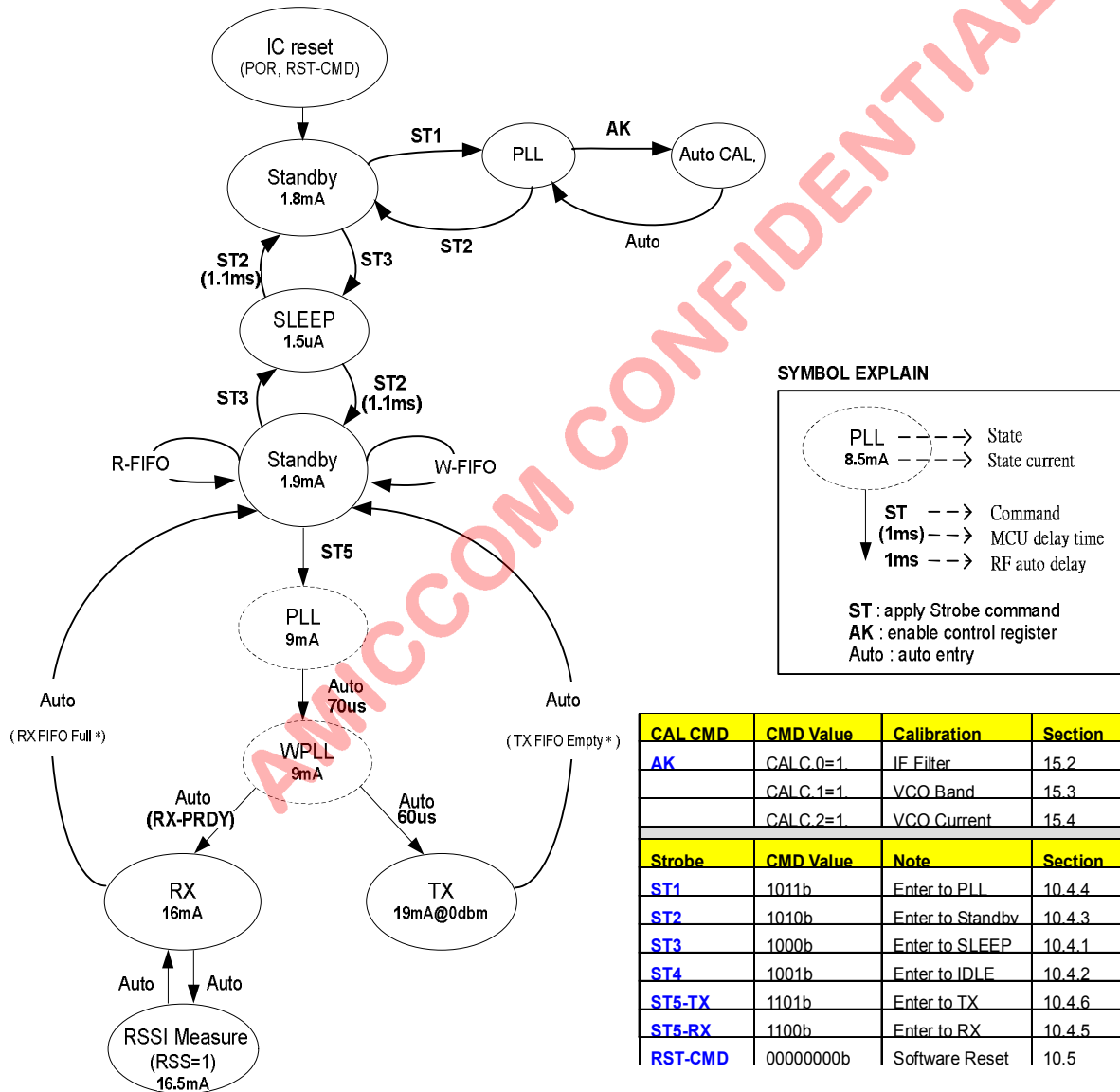

- Refer to chapter 16 for definition of RX FIFO Full and TX FIFO Empty.
- RX-PRDY is depended on different data rate operation. See next page.

Figure 11.1 State diagram of Normal FIFO Mode

From Figure 11.1, when ST5 command is issued for TX operation, see Figure 11.2 for detailed timing. A7105 status can be represented to GIO1 or GIO2 pin to MCU for timing control.

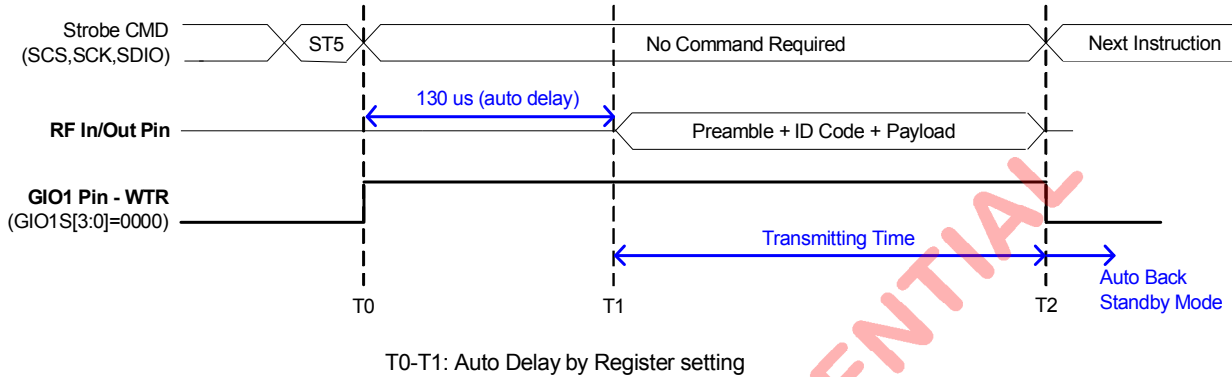

LO Freq.	Standby to WPLL	WPLL to TX	TX Ready Time
Changed	70 us	60 us	130 us
No Changed	70 us	60 us	130 us

Figure 11.2 Transmitting Timing Chart of Normal FIFO Mode

From Figure 11.1, when ST5 command is issued for RX operation, see Figure 11.3 for detailed timing. A7105 status can be represented to GIO1 or GIO2 pin to MCU for timing control.

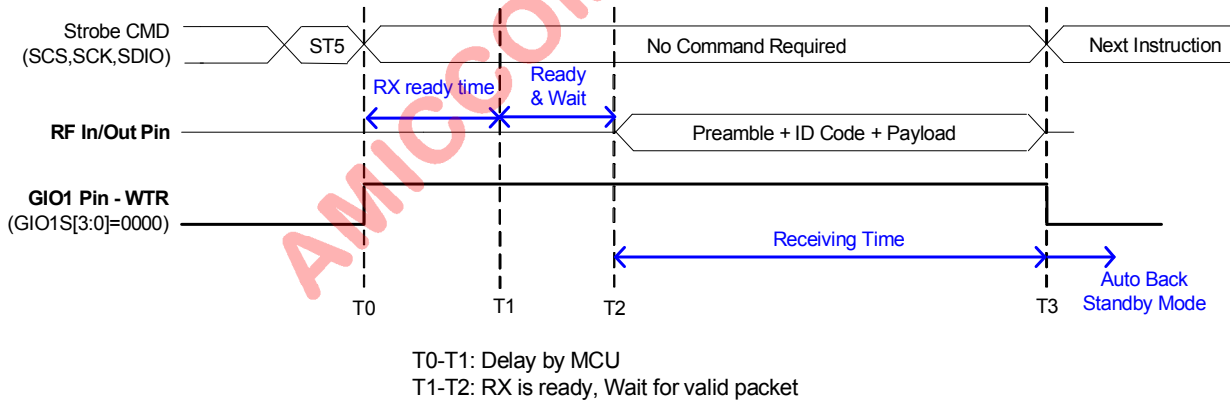

LO Freq.	Date Rate (bps)	DCM[1:0] (29h)	Standby to WPLL	WPLL to RX (RX-PRDY)	RX Ready Time (Delay by MCU)
Changed / Fixed	<=125K	By preamble (01b)	70 us	40 us	110 us
Changed / Fixed	250K	By ID (10b)	70 us	100 us	170 us
Changed / Fixed	500K	By ID (10b)	70 us	60 us	130 us

Figure 11.3 Receiving Timing Chart of Normal FIFO Mode



**11.3 Quick FIFO Mode**

This mode is suitable for requirement of fast transceiving. After calibration flow, user can issue Strobe command to enter PLL mode where write TX FIFO or read RX FIFO. From PLL mode to packet data transceiving, only one Strobe command is needed. Once transceiving is finished, A7105 is auto back to PLL mode.

When packets are finished and deeper power saving is necessary, user can issue Strobe command to ask A7105 staying in sleep mode. Figure 11.4 is the state diagram of Quick FIFO mode.

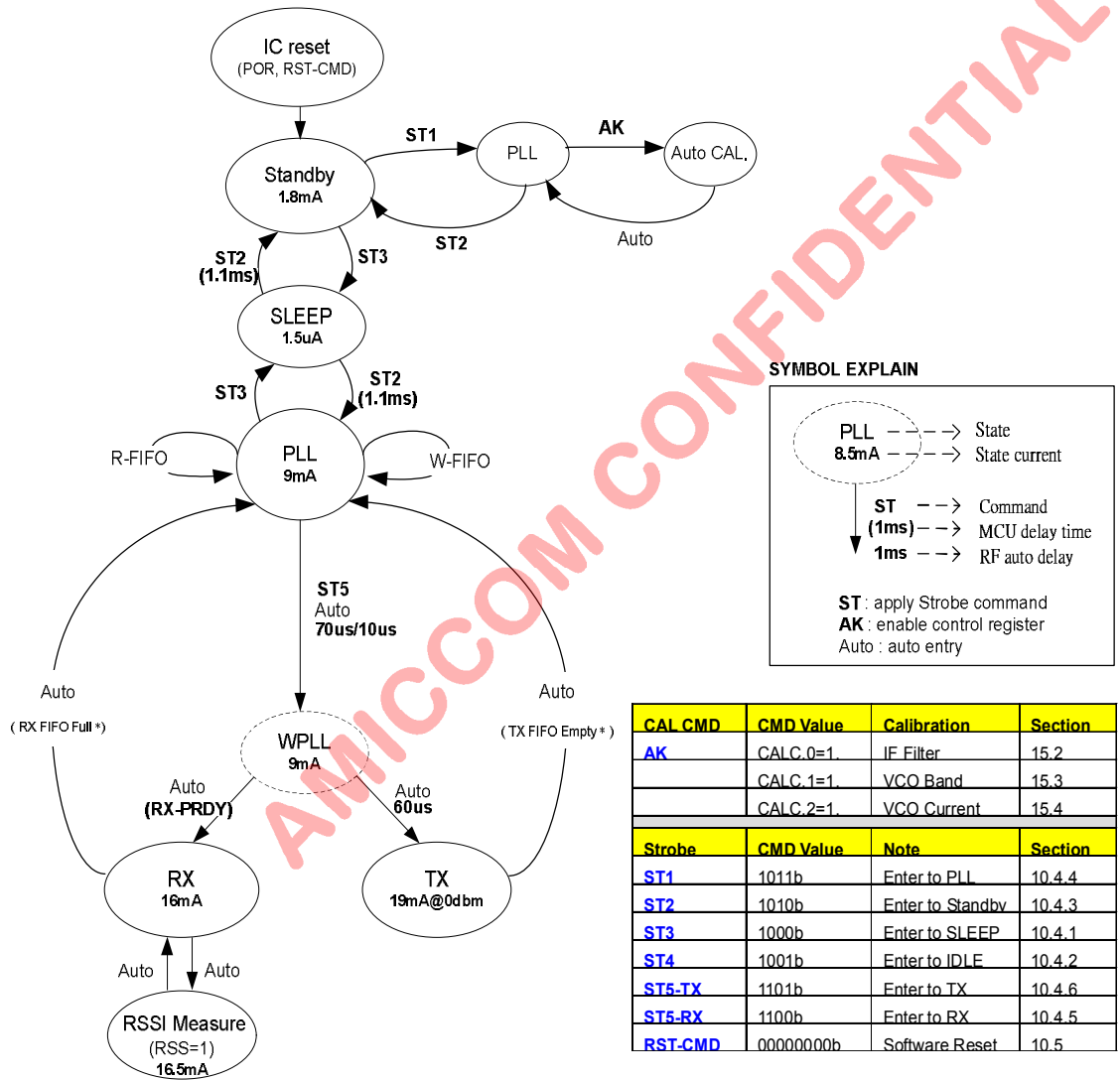

- Refer to chapter 16 for definition of RX FIFO Full and TX FIFO Empty.
- RX-PRDY means RX settling time depending on different data rate operation. See next page.
- From PLL to WPLL, 60 us for changing LO frequency, 10 us for the same LO frequency.

Figure 11.4 State diagram of Quick FIFO Mode

From Figure 11.4, when ST5 command is issued for TX operation, see Figure 11.5 for detailed timing. A7105 status can be represented to GIO1 or GIO2 pin to MCU for timing control.

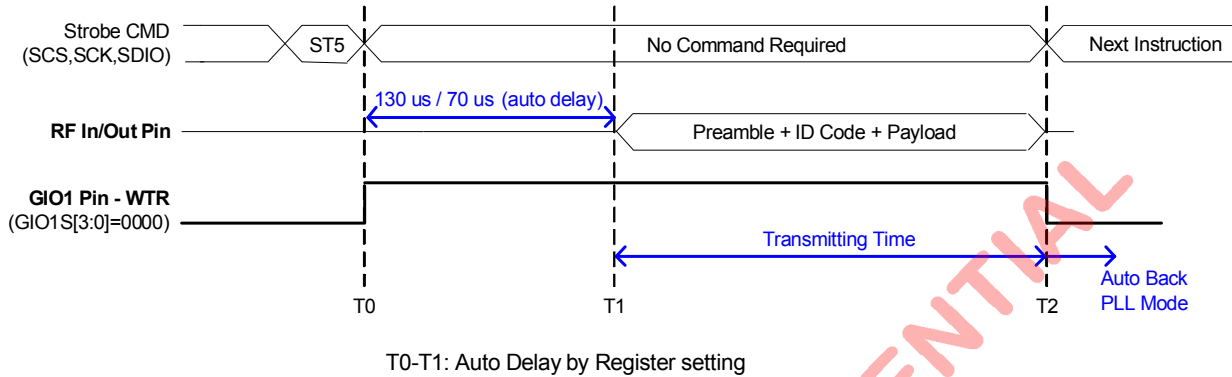

LO Freq.	PLL to WPLL	WPLL to TX	TX Ready Time
Changed	70 us	60 us	130 us
No Changed	10 us	60 us	70 us

Figure 11.5 Transmitting Timing Chart of Quick FIFO Mode

From Figure 11.4, when ST5 command is issued for RX operation, see Figure 11.6 for detailed timing. A7105 status can be represented to GIO1 or GIO2 pin to MCU for timing control.

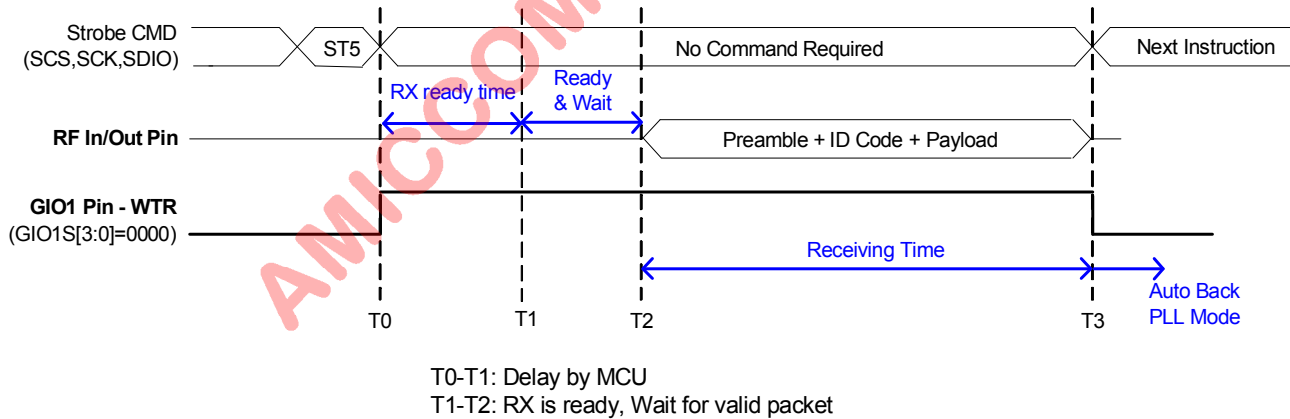

LO Freq.	Date Rate (bps)	DCM[1:0] (29h)	PLL to WPLL	WPLL to RX (RX-PRDY)	RX Ready Time (Delay by MCU)
Changed	<=125K	By preamble (01b)	70 us	40 us	110 us
Changed	250K	By ID (10b)	70 us	100 us	170 us
Changed	500K	By ID (10b)	70 us	60 us	130 us
Fixed	<=125K	By preamble (01b)	10 us	40 us	50 us
Fixed	250K	By ID (10b)	10 us	100 us	110 us
Fixed	500K	By ID (10b)	10 us	60 us	70 us

Figure 11.6 Receiving Timing Chart of Quick FIFO Mode

**11.4 Power Saving FIFO Mode**

This mode is suitable for requirement of low power consumption. After calibration flow, user can issue Strobe command to enter idle mode where write TX FIFO or read RX FIFO. From idle mode to packet data transceiving, only one Strobe command is needed. Once transmission is done, A7105 is auto back to idle mode.

When packets are finished and deeper power saving is necessary, user can issue Strobe command to ask A7105 staying in sleep mode. Figure 11.7 is the state diagram of Power Saving FIFO mode.

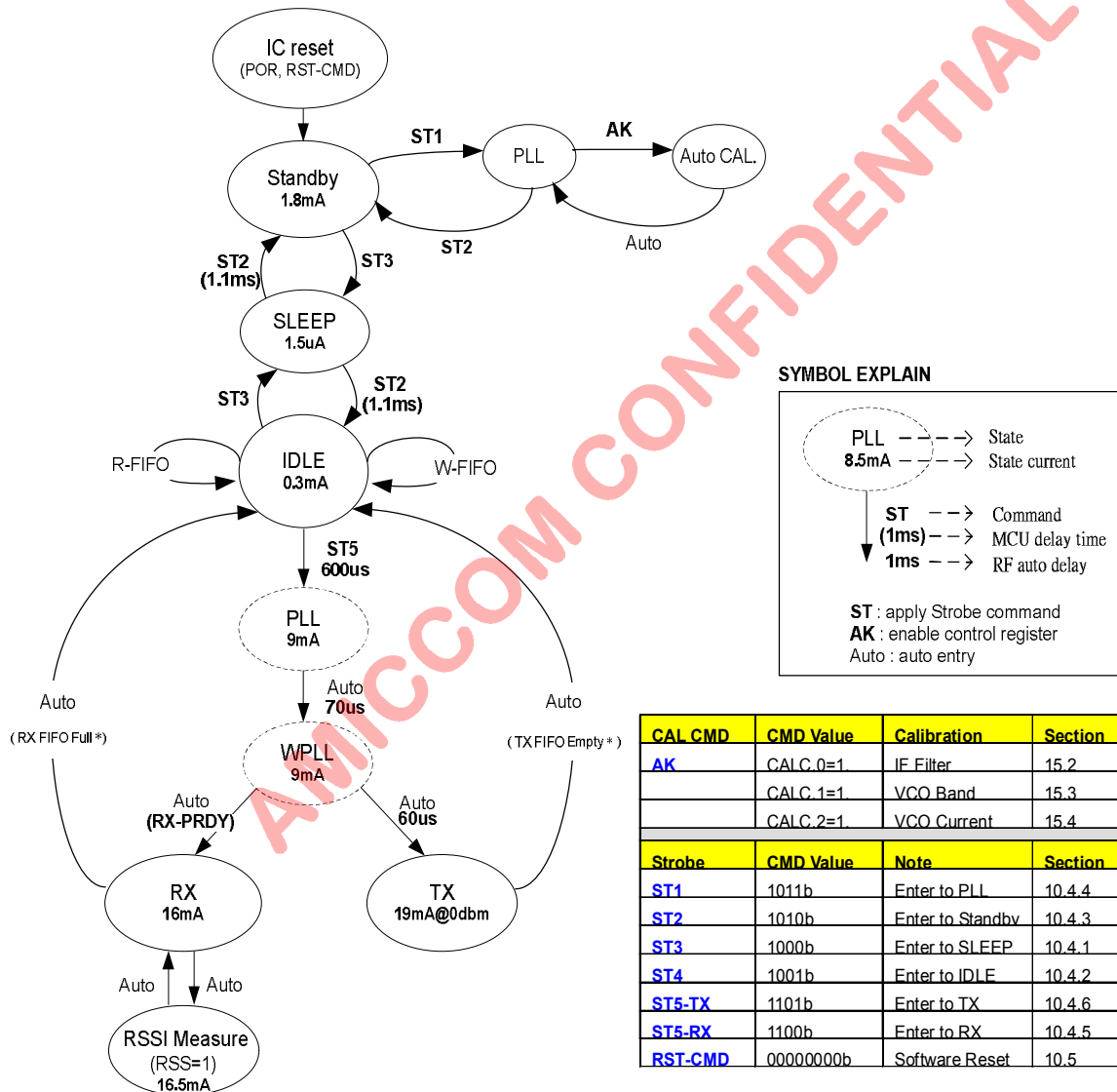

- Refer to chapter 16 for definition of RX FIFO Full and TX FIFO Empty.
- RX-PRDY is depended on different data rate operation. See next page.

Figure 11.7 State diagram of Power Saving FIFO Mode

From Figure 11.7, when ST5 command is issued for TX operation, see Figure 11.8 for detailed timing. A7105 status can be represented to GIO1 or GIO2 pin to MCU for timing control.

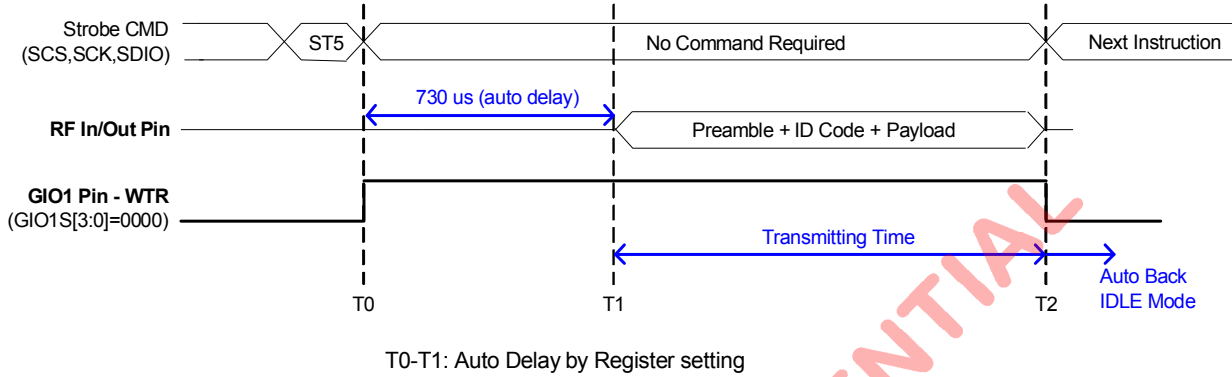

LO Freq.	IDLE to WPLL	WPLL to TX	TX Ready Time
Changed	670 us	60 us	730 us
No Changed	670 us	60 us	730 us

Figure 11.8 Transmitting Timing Chart of Power Saving FIFO Mode

From Figure 11.7, when ST5 command is issued for RX operation, see Figure 11.9 for detailed timing. A7105 status can be represented to GIO1 or GIO2 pin to MCU for timing control.

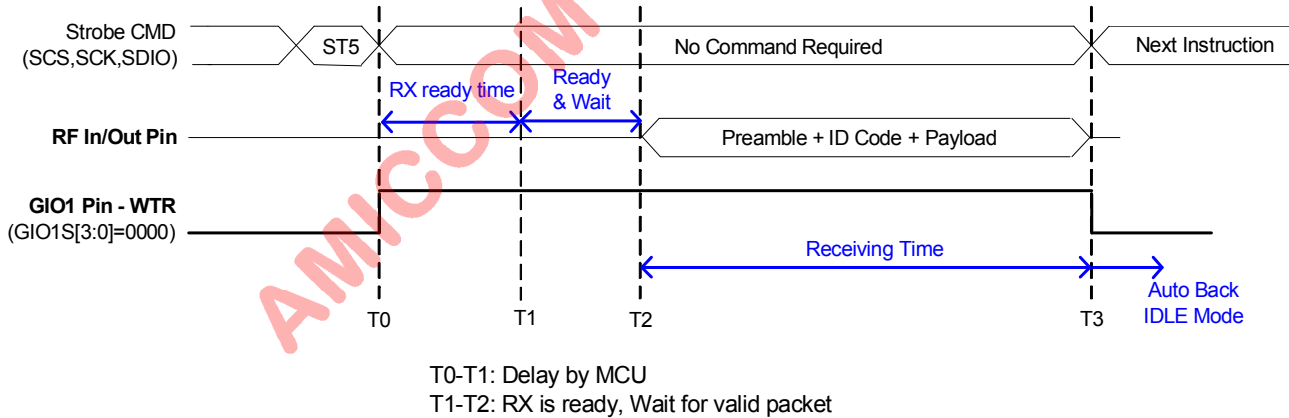

LO Freq.	Date Rate (bps)	DCM[1:0] (29h)	IDLE to WPLL	WPLL to RX (RX-PRDY)	RX Ready Time (Delay by MCU)
Changed / Fixed	<=125K	By preamble (01b)	670 us	40 us	710 us
Changed / Fixed	250K	By ID (10b)	670 us	100 us	770 us
Changed / Fixed	500K	By ID (10b)	670 us	60 us	720 us

Figure 11.9 Receiving Timing Chart of Power Saving FIFO Mode

### 11.5 Quick Direct Mode

This mode is suitable for fast transceiving. After calibration flow, for every state transition, user has to issue Strobe command to A7105. This mode is also suitable for the requirement of versatile packet format. Noted that user needs to take care the transition time by MCU's timer.

When packets are finished and deeper power saving is necessary, user can issue Strobe command to ask A7105 staying in idle mode (or sleep mode). Figure 11.3 is the state diagram of Quick Direct mode.

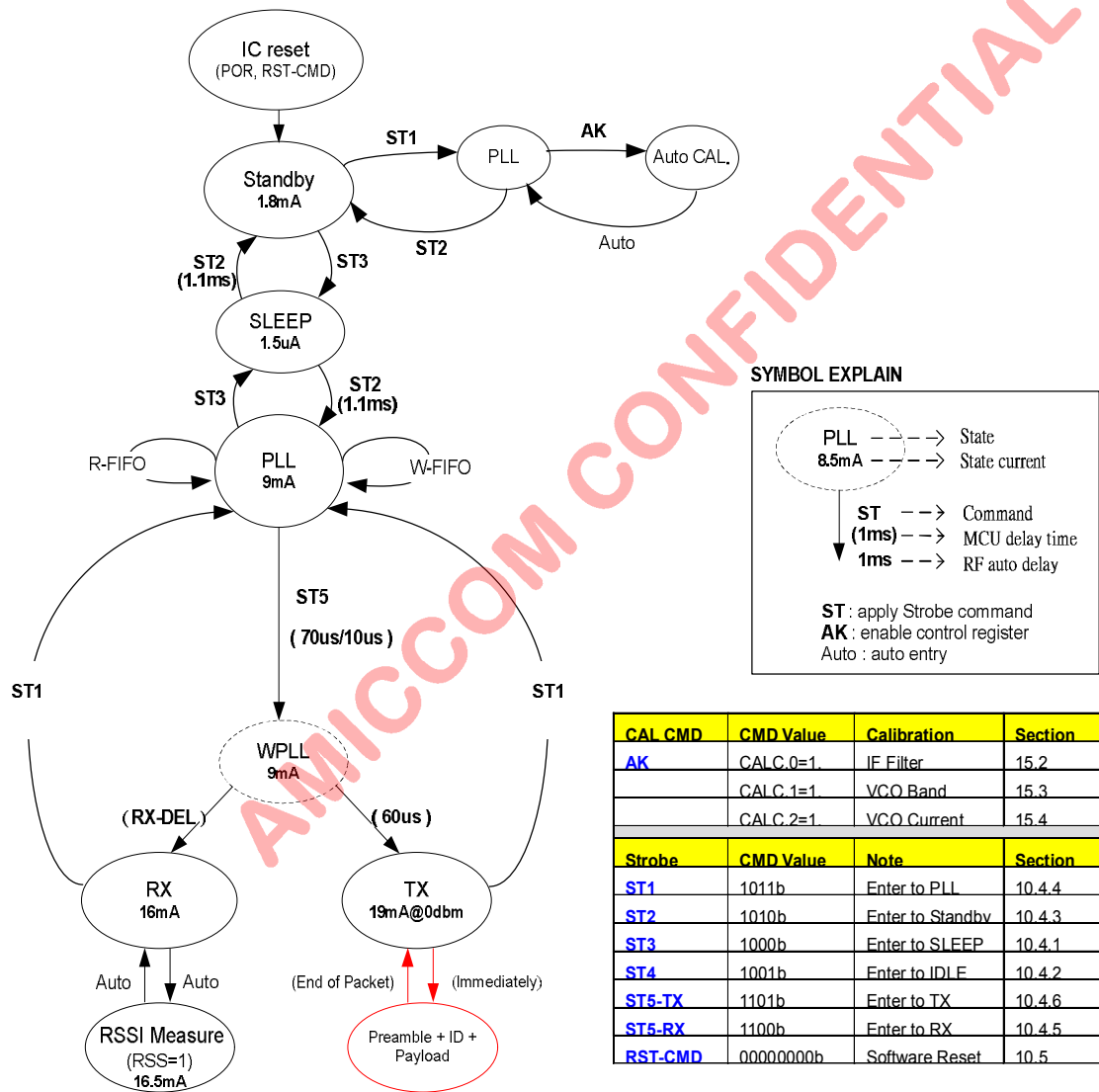

- Refer to chapter 16 for definition of RX FIFO Full and TX FIFO Empty.
- RX-TAB means RX settling time depending on different data rate operation. See next page for RX-TAB.
- From PLL to WPLL, 60 us for changing LO frequency, 10 us for the same LO frequency.

Figure 11.10 State diagram of Quick Direct Mode

From Figure 11.10, After A7105 enters TX mode, MCU should immediately deliver preamble and defined packet to A7105's GIO1 or GIO2 pin. From Figure 11.10, Table 11.1, When ST5 command is issued for TX operation; see Figure 11.11 for detailed timing. A7105 status can be represented to GIO1 and GIO2 pin to MCU for timing control.

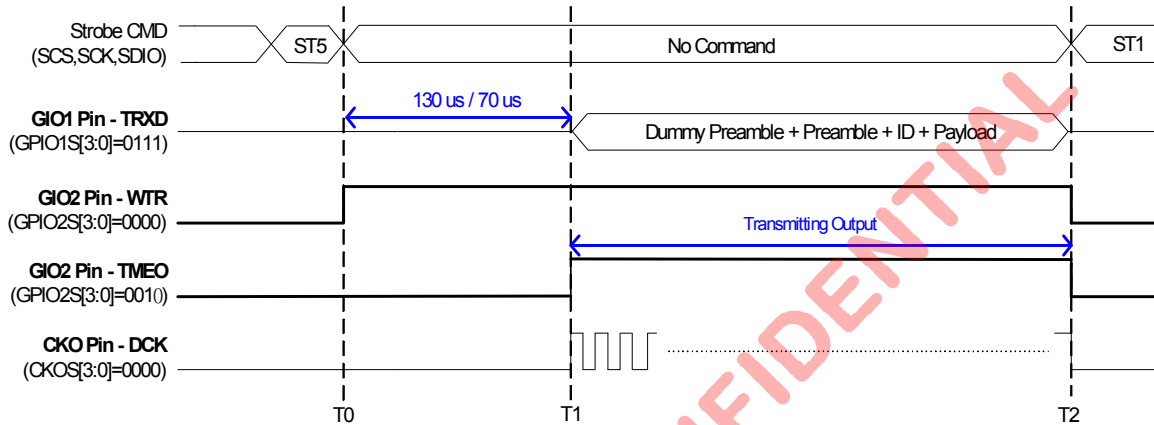

T0-T1: TX Ready Time by MCU delay timer

T1-T2: MCU could refer to recovery clock (DCK) to delivery packet immediately.

LO Freq.	PLL to WPLL	WPLL to TX	TX Ready Time
Changed	70 us	60 us	130 us
No Changed	10 us	60 us	70 us

Figure 11.11 Transmitting Timing Chart of Quick Direct Mode

From Figure 11.10, MCU has to handle every transition and necessary delay timing for radio control. When ST5 command is issued for RX operation, from Figure 11.12, based on recovery clock (DCK), MCU has to decode received ID and payload from GIO1 pin (TRXD). GIO2 pin is either used to inform MCU for PMDO (Preamble Detect Output) or FSYNC (Frame Sync).

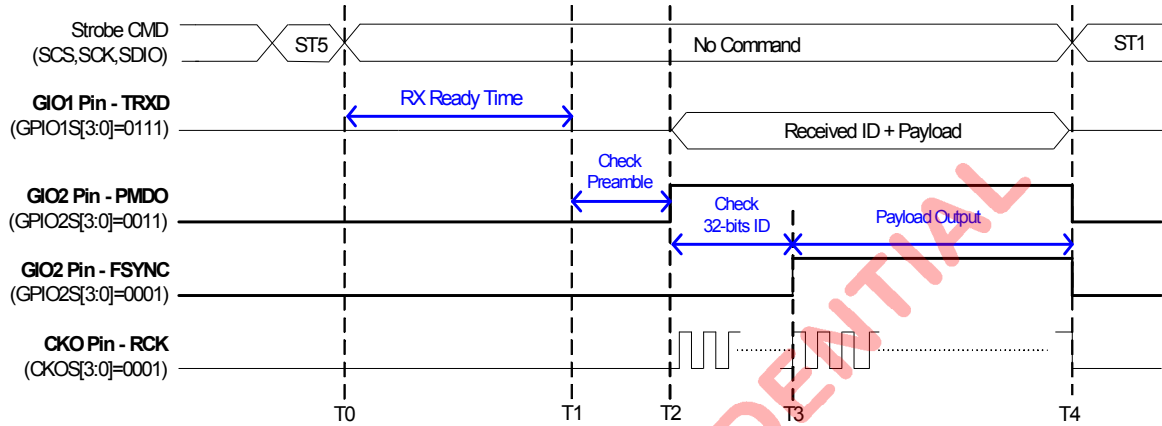

T0-T1: RX Ready Time by MCU Delay Timer  
 T1-T2: Check Preamble  
 T2-T3: Check 32-bits ID  
 T3-T4: Payload Output

LO Freq.	Date Rate (bps)	DCM[1:0] (29h)	PLL to WPLL	WPLL to RX (RX-PRDY)	RX Ready Time (Delay by MCU)
Changed	<=125K	By preamble (01b)	70 us	40 us	110 us
Changed	250K	By ID (10b)	70 us	100 us	170 us
Changed	500K	By ID (10b)	70 us	60 us	130 us
No Changed	<=125K	By preamble (01b)	10 us	40 us	50 us
No Changed	250K	By ID (10b)	10 us	100 us	110 us
No Changed	500K	By ID (10b)	10 us	60 us	70 us

Figure 11.12 Receiving Timing Chart of Quick Direct Mode

## 12 Crystal Oscillator

A7105 needs external crystal or external clock that is either 6 or 8/12/16/20/24 MHz to generate internal wanted clock. Be notice if external clock is lower than 8MHz, A7105 only supports data rate up to 250K.

### Relative Control Register

Clock Register (Address: 0Dh)

Name	R/W	Bit 7	Bit 6	Bit 5	Bit 4	Bit 3	Bit 2	Bit 1	Bit 0
Clock	R/W	GRC3	GRC2	GRC1	GRC0	CSC1	CSC0	CGS	XS
Reset		1	1	1	1	0	1	0	1

### 12.1 Use External Crystal

Figure 12.1 shows the connection of crystal network between XI and XO pins. C1 and C2 capacitance are used to adjust different crystal loading. A7105 supports crystal accuracy within  $\pm 20$  ppm under firmware frequency compensation. Be noted that crystal accuracy requirement includes initial tolerance, temperature drift, aging and crystal loading.

A7105	Crystal Accuracy
Firmware FC = On	$\pm 20$ ppm
Firmware FC = Off	$\pm 10$ ppm

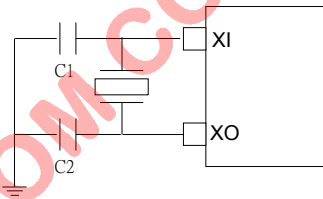

Fig12.1 Crystal oscillator circuit

### 12.2 Use external clock

A7105 has built-in AC couple capacitor to support external clock input. Figure 11.2 shows how to connect. In such case, XI pin is left opened.

Be notice, to set XS = 0 (0Dh) by selecting external clock, the frequency accuracy of external clock shall be controlled within  $\pm 25$  ppm.

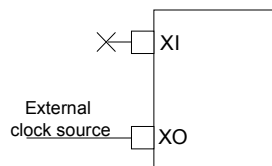

Fig12.2 Connection of external clock source to A7105



**13. System Clock**

A7105 supports different external crystal frequency by programmable “Clock Register” (0Dh). Based on this, three important internal clocks  $F_{CGR}$ ,  $F_{DR}$  and  $F_{SYCK}$  are generated.

- (1)  $F_{XTAL}$ : Crystal frequency.
- (2)  $F_{XREF}$ : Crystal Ref. Clock =  $F_{XREF} * (DBL+1)$ .
- (3)  $F_{CGR}$ : Clock Generation Reference =  $2MHz = F_{XREF} / (GRC+1)$ , where  $F_{CGR}$  is used to generate 32M PLL.
- (4)  $F_{MCLK}$ : Master Clock is either  $F_{XREF}$ : or 32M PLL, where  $F_{MCLK}$  is used to generate  $F_{SYCK}$ .
- (5)  $F_{SYCK}$ : System Clock =  $16MHz = F_{MCLK} / CSC = 32 * F_{IF}$ , where  $F_{IF}$  is recommended to set 500KHz.
- (6)  $F_{DR}$ : Data Rate Clock =  $F_{IF} / (SDR+1)$ .
- (7)  $F_{PPD}$ : VCO Compared Clock =  $F_{XREF} / (RRC+1)$ .

**Relative Control Register**

Clock Register (Address: 0Dh)

Name	R/W	Bit 7	Bit 6	Bit 5	Bit 4	Bit 3	Bit 2	Bit 1	Bit 0
Clock	R/W	GRC3	GRC2	GRC1	GRC0	CSC1	CSC0	CGS	XS
Reset		1	1	1	1	0	1	0	1

Data Rate Register (Address: 0Eh)

Name	R/W	Bit 7	Bit 6	Bit 5	Bit 4	Bit 3	Bit 2	Bit 1	Bit 0
Data Rate	R/W	SDR7	SDR6	SDR5	SDR4	SDR3	SDR2	SDR1	SDR0
Reset		0	0	0	0	0	0	0	0

PLL Register II (Address: 10h)

Name	R/W	Bit 7	Bit 6	Bit 5	Bit 4	Bit 3	Bit 2	Bit 1	Bit 0
PLL II	W	DBL	RRC1	RRC0	CHR3	CHR2	CHR1	CHR0	BIP8
	R	DBL	RRC1	RRC0	CHR3	CHR2	CHR1	CHR0	IP8
Reset		1	0	0	1	1	1	1	0

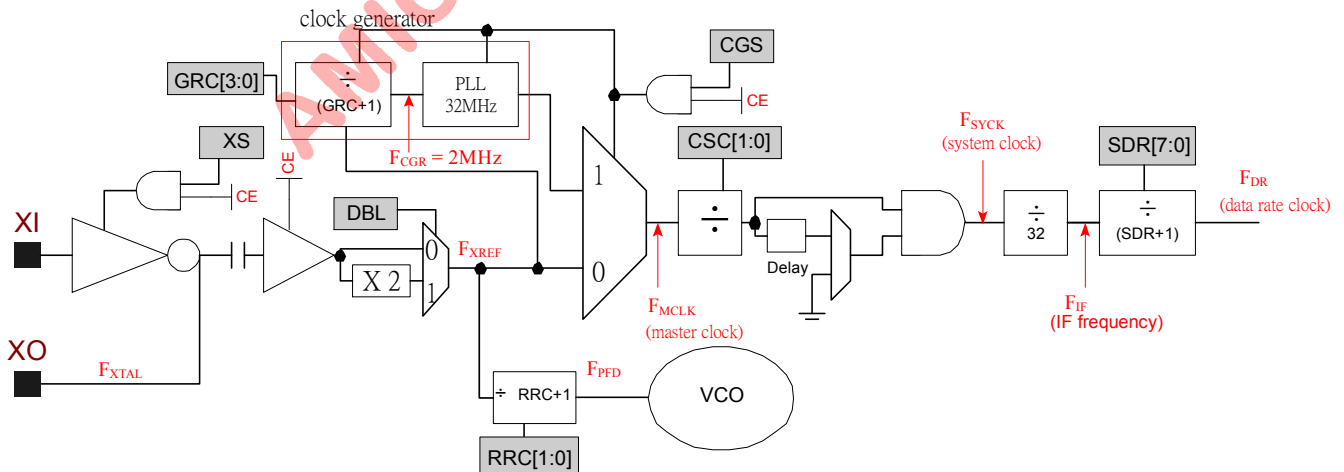

Fig13.1 System clock block diagram

As show in Fig 13.1,  $F_{MCLK}$ , the master clock either come from  $F_{XREF}$  (CGS = 0) or PLL 32MHz (CGS = 1). The relation between  $F_{SYCK}$  (the system clock) and  $F_{MCLK}$  (master clock) show in table 13.1

<b><math>F_{SYCK}</math> (Master Clock)</b>		
	CGS = 0	CGS = 1
DBL=0	$F_{XTAL}$	32 MHz
DBL=1	$2 * F_{XTAL}$	32 MHz

<b>CSC [1:0]</b>	<b><math>F_{SYCK}</math> (system clock)</b>	<b>Note</b>
00	$F_{MCLK}$	$F_{SYCK}$ is used to determine
01	$F_{MCLK} / 2$	1. Data rate clock (0Eh)
10	$F_{MCLK} / 2$	2. ADC clock (1Eh)
11	$F_{MCLK} / 4$	3. Internal digital clock (09h)
		4. CKO pin (0Ah)

Table 13.1 System clock and master clock

**13.1 Bypass clock generation**

If crystal frequency is multiplier of 8MHz, the clock generator block can be turned off by setting CGS = 0. The relation between  $F_{XTAL}$  (crystal frequency) and data rate show below:

$$F_{XREF} = F_{XTAL} * (DBL+1)$$

$$F_{PPD} = F_{XREF} / (RRC [1:0]+1)$$

$$F_{DR} = F_{XREF} / (CSC [1:0]+1) / 32 / (SDR+1)$$

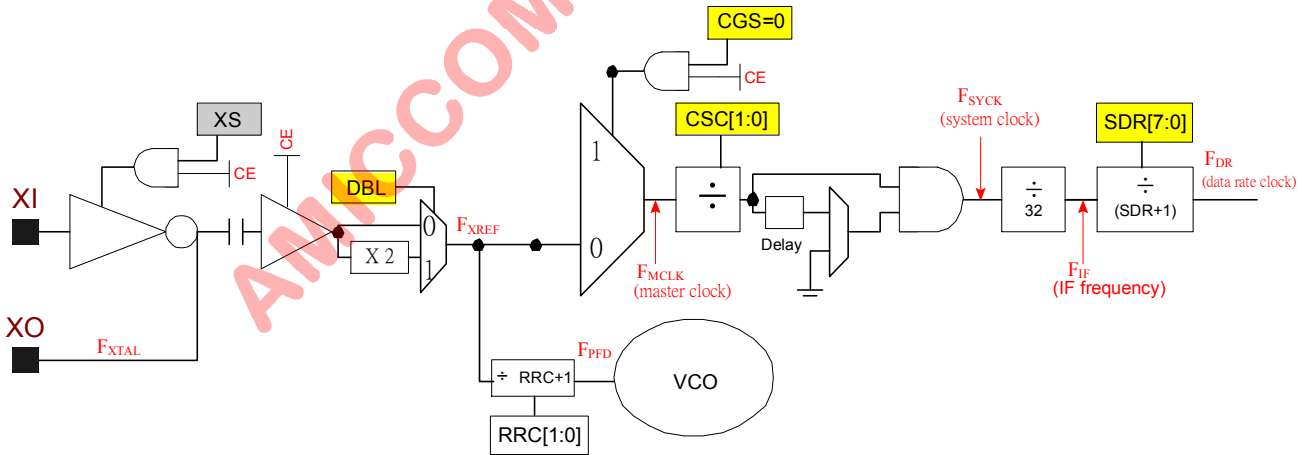

Fig13.2 By pass clock generator to get system clock

For various data rate application, the setting examples list below.  
For more data rate options, please contact AMICCOM FAE team for details.

**Data rate 500Kbps**

Crystal source	CGS (0Dh)	DBL (10h)	CSC[1:0] (0Dh)	GRC [3:0] (0Dh)	$F_{IF}$ (KHz)	BWS (18h)	RRC [1:0] (10h)	$F_{PPD}$ (MHz)	CHR [3:0] (10h)	$F_{CHSP}$ (MHz)	SDR [7:0]
16MHz	0	1	01	Don't care	500	1	00	32	1111	0.5	0x00

**Data rate = 250K / 125K / 100K / 50K / 25K / 10K / 2Kbps**

Crystal source	CGS (0Dh)	DBL (10h)	CSC[1:0] (0Dh)	GRC [3:0] (0Dh)	F <sub>IF</sub> (KHz)	BWS (18h)	RRC [1:0] (10h)	F <sub>PPFD</sub> (MHz)	CHR [3:0] (10h)	F <sub>CHSP</sub> (MHz)	SDR [7:0]
8MHz	0	1	01	Don't care	500	1	00	16	0111	0.5	See next table
16MHz								32	1111		

**SDR Table**

	250Kbps	125Kbps	100Kbps	50Kbps	25Kbps	10Kbps	2Kbps
SDR [7:0]	0x01	0x03	0x04	0x09	0x13	0x31	0xF9

**13.2 Enable clock generation**

If crystal frequency is the multiplier of 2MHz and larger than 6MHz,  $F_{SYCK} = 32MHz$  by setting  $CGS = 1$  because the clock generation is 32MHz. The comparison frequency of clock generator  $F_{CGR}$  shall be 2MHz by setting  $GRC[3:0]$  to meets the below equations.

$$F_{CRG} = F_{XTAL} * (1+DBL) / (GRC+1) = 2MHz.$$

$$F_{DR} = F_{SYCK} / 32 / (SDR+1).$$

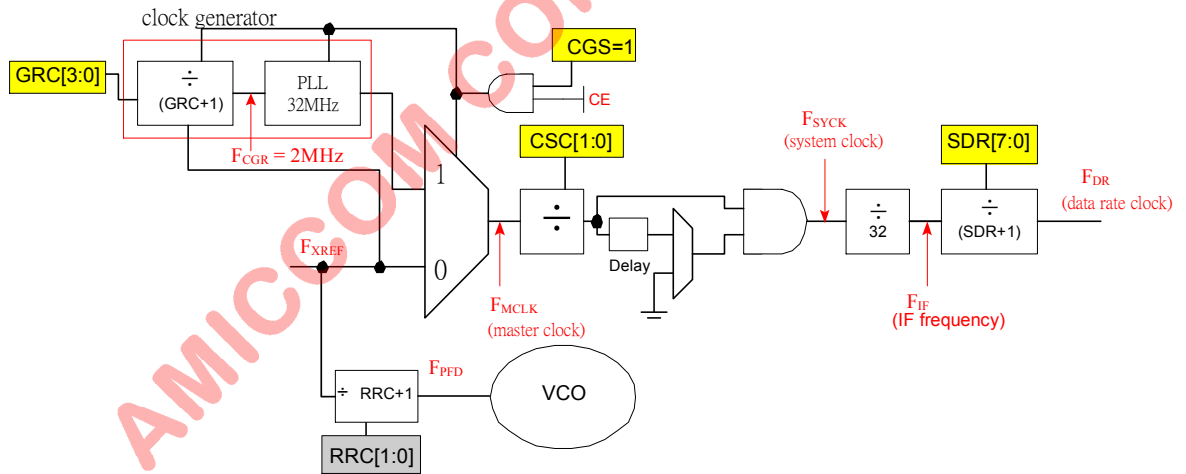

Fig13.3 Enable clock generator to get system clock

For various data rate application, the setting examples list below.  
 For more data rate options, please contact AMICCOM FAE team for details.



**Data rate 500Kbps**

Crystal source	CGS (0Dh)	DBL (10h)	CSC[1:0] (0Dh)	GRC [3:0] (0Dh)	F <sub>IF</sub> (KHz)	BWS (18h)	RRC [1:0] (10h)	F <sub>PPFD</sub> (MHz)	CHR [3:0] (10h)	F <sub>CHSP</sub> (MHz)	SDR [7:0]
12MHz	1	1	01	1011	500	1	00	24	1011	0.5	0x00
16MHz		1		1111				32	1111		
24MHz		0		1011				24	1011		

**Data rate = 250K / 125K / 100K / 50K / 25K / 10K / 2Kbps**

Crystal source	CGS (0Dh)	DBL (10h)	CSC[1:0] (0Dh)	GRC [3:0] (0Dh)	F <sub>IF</sub> (KHz)	BWS (18h)	RRC [1:0] (10h)	F <sub>PPFD</sub> (MHz)	CHR [3:0] (10h)	F <sub>CHSP</sub> (MHz)	SDR [7:0]
6MHz	1	1	01	0101	500	1	00	12	0101	0.5	See next table
8MHz		1		0111				16	0111		
12MHz		1		1011				24	1011		
16MHz		1		1111				32	1111		
24MHz		0		1011				24	1011		
								24	1011		

**SDR Table**

	250Kbps	125Kbps	100Kbps	50Kbps	25Kbps	10Kbps	2Kbps
SDR [7:0]	0x01	0x03	0x04	0x09	0x13	0x31	0xF9

AMICCOM CONFIDENTIAL

**14. Transceiver LO Frequency**

A7105 is a half-duplex transceiver with embedded PA and LNA. For TX or RX frequency setting, user just needs to set up LO (Local Oscillator) frequency for two ways radio transmission.

To target full range of 2.4GHz ISM band (2400 MHz to 2483.5 MHz), A7105 applies offset concept by LO frequency  $F_{LO} = F_{LO\_BASE} + F_{OFFSET}$ . Therefore, for 2.4GHz applications, A7105 is easy to implement frequency hopping and multi-channels by **ONE** register setting, **PLL Register I (CHN [7:0], 0Eh)**.

Below is the LO frequency block diagram.

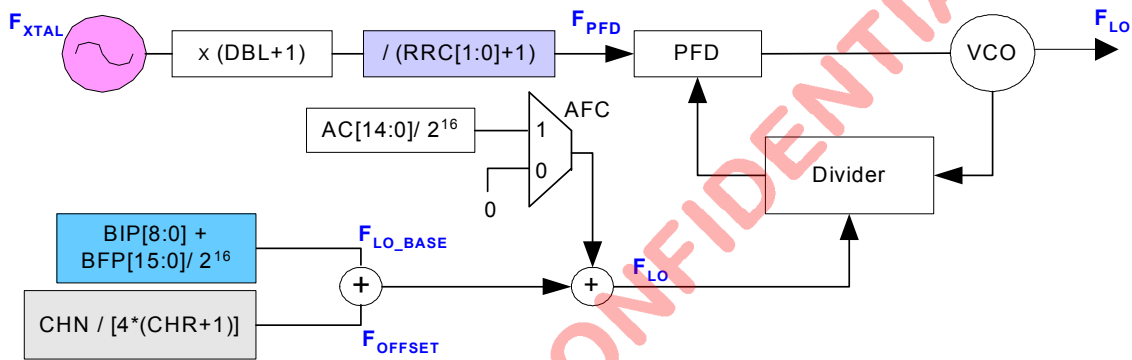

Fig14.1 Frequency synthesizer block diagram

**Relative Control Register**

PLL Register I (Address: 0Fh)

Name	R/W	Bit 7	Bit 6	Bit 5	Bit 4	Bit 3	Bit 2	Bit 1	Bit 0
PLL I	R/W	CHN7	CHN6	CHN5	CHN4	CHN3	CHN2	CHN1	CHN0
Reset		0	0	0	0	0	0	0	0

PLL Register II (Address: 10h)

Name	R/W	Bit 7	Bit 6	Bit 5	Bit 4	Bit 3	Bit 2	Bit 1	Bit 0
PLL II	W	DBL	RRC1	RRC0	CHR3	CHR2	CHR1	CHR0	BIP8
	R	DBL	RRC1	RRC0	CHR3	CHR2	CHR1	CHR0	IP8
Reset		1	0	0	1	1	1	1	0

PLL Register III (Address: 11h)

Name	R/W	Bit 7	Bit 6	Bit 5	Bit 4	Bit 3	Bit 2	Bit 1	Bit 0
PLL III	W	BIP7	BIP6	BIP5	BIP4	BIP3	BIP2	BIP1	BIP0
	R	IP7	IP6	IP5	IP4	IP3	IP2	IP1	IP0
Reset		0	1	0	0	1	0	1	1

PLL Register IV (Address: 12h)

Name	R/W	Bit 7	Bit 6	Bit 5	Bit 4	Bit 3	Bit 2	Bit 1	Bit 0
PLL IV	W	BFP15	BFP14	BFP13	BFP12	BFP11	BFP10	BFP9	BFP8
	R	--/FP15	AC14/FP14	AC13/FP13	AC12/FP12	AC11/FP11	AC10/FP10	AC9/FP9	AC8/FP8
Reset		0	0	0	0	0	0	0	0

PLL Register V (Address: 13h)

Name	R/W	Bit 7	Bit 6	Bit 5	Bit 4	Bit 3	Bit 2	Bit 1	Bit 0

PLL V	W	BFP7	BFP6	BFP5	BFP4	BFP3	BFP2	BFP1	BFP0
	R	AC7/FP7	AC6/FP6	AC5/FP5	AC4/FP4	AC3/FP3	AC2/FP2	AC1/FP1	AC0/FP0
Reset		0	0	0	0	0	0	1	1

RX Register (Address: 18h)

Name	R/W	Bit 7	Bit 6	Bit 5	Bit 4	Bit 3	Bit 2	Bit 1	Bit 0
RX	W	--	RXSM1	RXSM0	FC	RXDI	DMG	BWS	ULS
Reset		--	1	0	0	0	0	1	0

Mode Control Register (Address: 01h)

Name	R/W	Bit 7	Bit 6	Bit 5	Bit 4	Bit 3	Bit 2	Bit 1	Bit 0
Mode Control I	W	R	DDPC	ARSSI	AIF	CD	WWSE	FMT	FMS
	R	W	DDPC	ARSSI	AIF	DFCD	WWSE	FMT	FMS
Reset		0	0	0	0	0	0	0	0

### 14.1 LO Frequency Setting

From Figure 14.1,  $F_{LO}$  is not only for TX radio frequency but also to be RX LO frequency. To set up  $F_{LO}$ , it is easy to implement by below 7 steps.

- Set the base frequency ( $F_{LO\_BASE}$ ) by PLL Register II, III, IV and V (10h, 11h, 12h and 13h).  
**Recommend to set  $F_{LO\_BASE} \sim 2400.001\text{MHz}$ .**
- Set the channel step ( $F_{CHSP}$ ) by PLL Register II (0Fh).  
 **$F_{CHSP} = F_{XTAL} * (DBL+1) / 4 / (CHR+1)$ , Recommend  $F_{CHSP} = 500\text{ KHz}$ .**
- Set CHN [7:0] to get offset frequency by PLL Register I (0Fh).  
 **$F_{OFFSET} = CHN [7:0] * F_{CHSP}$**
- LO frequency is equal to base frequency plus offset frequency.  
 **$F_{LO} = F_{LO\_BASE} + F_{OFFSET}$**
- In TX mode, TX radio frequency ( $F_{TXRF}$ ) is equal to  $F_{LO}$ .  
 **$F_{TXRF} = F_{LO}$**

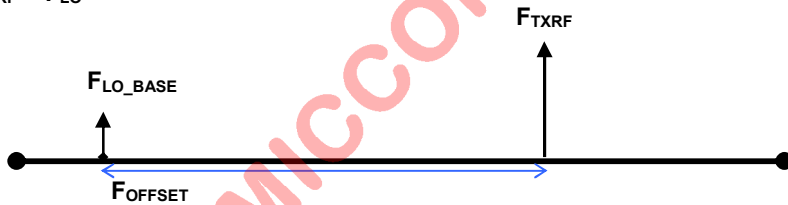

- Due to low-IF architecture, in RX mode, if  $ULS=0$ ,  $F_{RXLO} = F_{carrier} - F_{IF}$ , (Up side band).

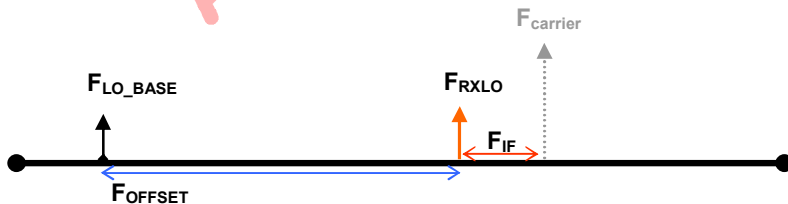

- Due to low-IF architecture, in RX mode, if  $ULS=1$ ,  $F_{RXLO} = F_{carrier} + F_{IF}$ , (Low side band).



$F_{LO\_BASE}$

$$F_{LO\_BASE} = F_{PPFD} \cdot \left( BIP[8:0] + \frac{BFP[15:0]}{2^{16}} \right) = (DBL + 1) \cdot \frac{F_{XTAL}}{RRC[1:0] + 1} \cdot \left( BIP[8:0] + \frac{BFP[15:0]}{2^{16}} \right)$$

Base on the above formula, for example, if  $F_{XTAL} = 16$  MHz and set channel step  $F_{CHSP} = 500$  KHz, to get  $F_{LO\_BASE}$  and  $F_{LO}$ , see Table 14.1, 14.2, and Figure 14.2 for details.

How to set  $F_{LO\_BASE} \sim 2400.001$  MHz

STEP	ITEMS	VALUE	NOTE
1	$F_{XTAL}$	16 MHz	Crystal Frequency
2	DBL	1	Enable double function
3	RRC	0	If so, $F_{PPFD} = 32$ MHz
4	BIP	0x4B	To get $F_{LO\_BASE} = 2400$ MHz
5	BFP	0x0002	To get $F_{LO\_BASE} \sim 2400.001$ MHz
6	$F_{LO\_BASE}$	<b><math>\sim 2400.001</math> MHz</b>	LO Base frequency

Table 14.1 How to set  $F_{LO\_BASE}$

How to set  $F_{TXRF} = F_{LO} = F_{LO\_BASE} + F_{OFFSET} \sim 2405.001$  MHz

STEP	ITEMS	VALUE	NOTE
1	$F_{LO\_BASE}$	$\sim 2400.001$ MHz	After set up BIP and BFP
2	CHR	0x0F	To get $F_{CHSP} = 500$ KHz
3	$F_{CHSP}$	500 KHz	Channel step = 500 KHz
4	CHN	0x0A	Set channel number = 10
5	$F_{OFFSET}$	5 MHz	$F_{OFFSET} = 500$ KHz * (CHN) = 5 MHz
6	$F_{LO}$	$\sim 2405.001$ MHz	Get $F_{LO} = F_{LO\_BASE} + F_{OFFSET}$
7	$F_{TXRF}$	<b><math>\sim 2405.001</math> MHz</b>	$F_{TXRF} = F_{LO}$

Table 14.2 How to set  $F_{TXRF}$

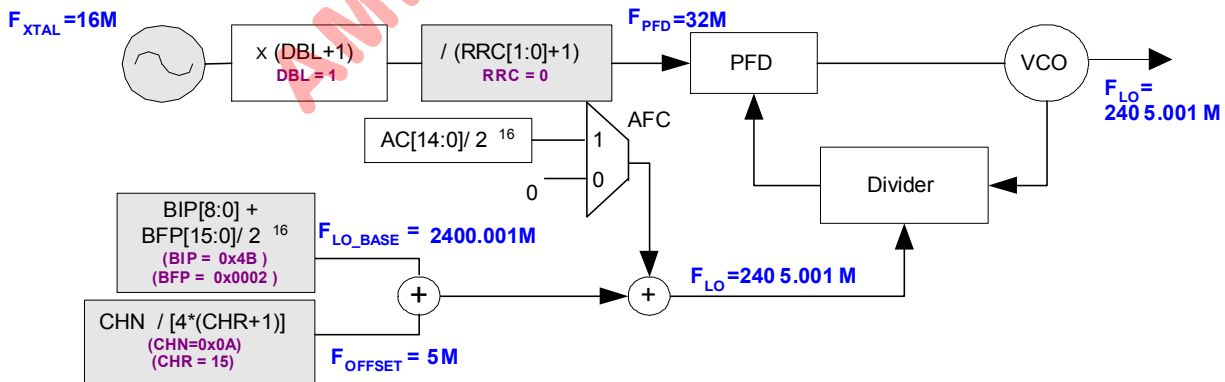

Figure 14.2 Block Diagram of set up  $F_{LO} \sim 2405.001$  MHz

For different crystal frequency, 24MHz / 16MHz / 12 MHz / 8MHz / 6MHz, below are calculation details for  $F_{\text{PFD}}$  and  $F_{\text{CHSP}}$

$$F_{\text{PFD}} = \frac{(DBL + 1) \cdot f_{\text{XTAL}}}{RRC[1:0] + 1}$$

**Different  $F_{\text{XTAL}}$  , How to set  $F_{\text{PFD}}$**

$F_{\text{XTAL}}$ (MHz)	DBL	RRC	$F_{\text{PFD}}$ (MHz)
24	0	0	24
16	1	0	32
12	1	0	24
8	1	0	16
6	1	0	12

$$F_{\text{CHSP}} = \frac{F_{\text{PFD}}}{4 \cdot (CHR[3:0] + 1)}$$

**Different  $F_{\text{XTAL}}$  , How to set  $F_{\text{CHSP}}$**

$F_{\text{XTAL}}$ (MHz)	$F_{\text{PFD}}$ (MHz)	CHR [3:0]	$F_{\text{CHSP}}$ (KHz)	CHN [7:0]	$F_{\text{OFFSET}}$ (MHz)	$F_{\text{LO}}$ (MHz)
24	24	1011	500	0x00 ~ 0xA8	0 ~ 84	2400 ~ 2484
16	32	1111	500	0x00 ~ 0xA8	0 ~ 84	2400 ~ 2484
12	24	1011	500	0x00 ~ 0xA8	0 ~ 84	2400 ~ 2484
8	16	0111	500	0x00 ~ 0xA8	0 ~ 84	2400 ~ 2484
6	12	0101	500	0x00 ~ 0xA8	0 ~ 84	2400 ~ 2484

## 14.2 IF Side Band Select

In two ways radio, both master and slave have two roles, TX and RX. In such case, A7105 offers two methods to set up  $F_{\text{LO}}$  while TRX exchanging.

- (1) Auto IF exchange
- (2) Fast exchange

### Relative Control Register

Mode Control Register (Address: 01h)

Bit	R/W	Bit 7	Bit 6	Bit 5	Bit 4	Bit 3	Bit 2	Bit 1	Bit 0
Name	R	DDPC	ARSSI	AIF	CD	WWSE	FMT	FMS	ADCM
	W	DDPC	ARSSI	AIF	DFCD	WWSE	FMT	FMS	ADCM
Reset		0	0	0	0	0	0	0	0

RX Register (Address: 18h)

Name	R/W	Bit 7	Bit 6	Bit 5	Bit 4	Bit 3	Bit 2	Bit 1	Bit 0
RX	W	--	RXSM1	RXSM0	FC	RXDI	DMG	BWS	ULS
Reset		--	1	0	0	0	0	1	0



### 14.2.1 Auto IF Exchange

A7105 supports Auto IF offset function (AIF, 01h). If AIF=1, user has no need to change CHN [7:0] for insert  $F_{IF}$  offset while TRX exchanging because  $F_{LO}$  is changed automatically. See Table 14.1 for details.

#### <Master>

AIF=1 and ULS=0,  $F_{RXLO}$  is auto shifted lower than  $F_{TXRF}$  for 500KHz ( $F_{IF}$ ).

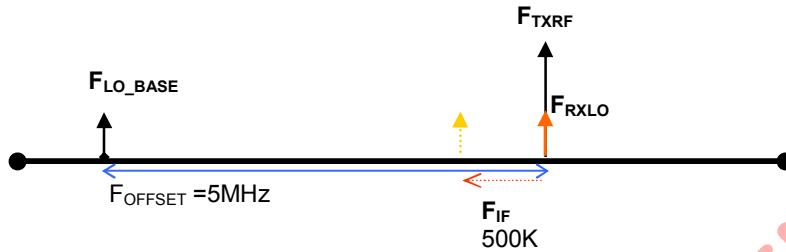

#### <Slave>

AIF=1 and ULS=0,  $F_{RXLO}$  is auto shifted lower than  $F_{TXRF}$  for 500KHz ( $F_{IF}$ ).

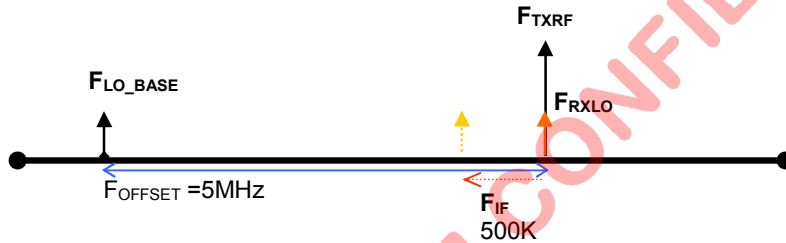

If Data rate = 500Kbps

Item	Role	AIF	ULS	CHN[7:0]	$F_{CHSP}$ (KHz)	$F_{TXRF}$ (KHz)	$F_{RXLO}$ (MHz)	NOTE
<b>Master</b>	TX	1	0	10	500	2405.001	-	
	RX	1	0	10	500	-	2404.501	Up side band $F_{RXLO}$ is auto shifted
<b>Slave</b>	TX	1	0	10	500	2405.001	-	
	RX	1	0	10	500	-	2404.501	Up side band $F_{RXLO}$ is auto shifted
Role Exchanging		Above setting is the same to Master and Slave.						
Switching Time		Refer to Figure 11.4, If A7105 delivers one packet and receives one packet, $F_{LO}$ is changed from 2405.001 to 2404.501, longer switching time.  Total Switching time = TX ready time + RX ready time = ( 70 us + 60 us ) + ( 70 us + 60 us ) = <b>260 us</b>						
On air occupied frequency		Master $F_{TXRF}$ = 2405.001 MHz Slave $F_{TXRF}$ = 2405.001 MHz						<b>ONE</b> occupied frequency.

Table 14.4 AIF function while TRX exchanging

### 14.2.2 Fast Exchange

To reduce PLL settling time, user can disable AIF function and control ULS = 1 (Master side) and ULS = 0 (Slave side) for fast exchange in two-way radio. See Table 14.5 for details.

<Master>

AIF=0 and ULS=1, Master is set Low side band.



<Slave>

AIF=0 and ULS=0, Slave is set Up side band.



If Data rate = 500Kbps

Item	Role	AIF	ULS	CHN[7:0]	F <sub>CHSP</sub> (KHz)	F <sub>TXRF</sub> (KHz)	F <sub>RXLO</sub> (MHz)	NOTE
<b>Master</b>	TX	0	1	10	500	2405.001	-	
	RX	0	1	10	500	-	2405.001	Low side band
<b>Slave</b>	TX	0	0	9	500	2404.501	-	
	RX	0	0	9	500	-	2404.501	Up side band
Role Exchanging		ULS and CHN setting are different in Master and Slave site.						
Settling Time		Refer to Figure 11.4, If A7105 delivers one packet and receives one packet, Master's F <sub>LO</sub> is fixed at 2405.001MHz, shorter settling time.  Total Settling time = TX ready time + RX ready time = ( 10 us + 60 us ) + ( 10 us + 60 us ) = <b>140 us</b>						
On air occupied frequency		Master F <sub>TXRF</sub> = 2405.001 MHz Slave F <sub>TXRF</sub> = 2404.501 MHz						TWO occupied on-air frequency.

Table 14.5 Fast exchange function while TRX exchanging

**14.3 Frequency Compensation**

Frequency Compensation function (FC) supports low accuracy crystal ( $\pm 20$  ppm) without sensitivity degradation. The FC concept is to fine tune RX LO frequency ( $F_{RXLO}$ ). MCU can read AC[14:0], (12h) and (13h), to executes frequency drift calculation and update new setting to PLL IV (12h) and PLL V (13h) to adjust the best RX LO frequency ( $F_{RXLO}$ ).

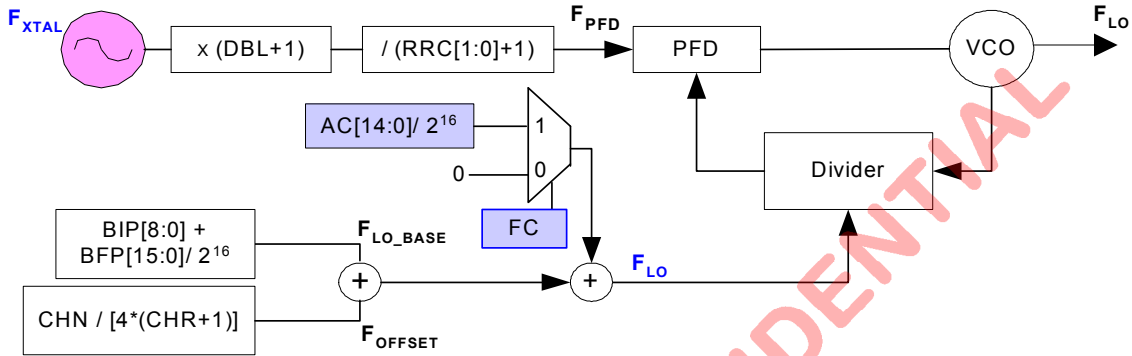

Figure 14.3 Block Diagram of enabling FC function

**Relative Control Register**

RX Register (Address: 19h)

Bit	R/W	Bit 7	Bit 6	Bit 5	Bit 4	Bit 3	Bit 2	Bit 1	Bit 0
Name	W	--	RXSM1	RXSM0	FC	RXDI	DMG	RAW	ULS
Reset		--	1	0	0	0	0	1	0

PLL Register IV (Address: 12h)

Bit	R/W	Bit 7	Bit 6	Bit 5	Bit 4	Bit 3	Bit 2	Bit 1	Bit 0
Name	R	--/FP15	AC14/FP14	AC13/FP13	AC12/FP12	AC11/FP11	AC10/FP10	AC9/FP9	AC8/FP8
	W	BFP15	BFP14	BFP13	BFP12	BFP11	BFP10	BFP9	BFP8
Reset		0	0	0	0	0	0	0	0

PLL Register V (Address: 13h)

Bit	R/W	Bit 7	Bit 6	Bit 5	Bit 4	Bit 3	Bit 2	Bit 1	Bit 0
Name	R	AC7/FP7	AC6/FP6	AC5/FP5	AC4/FP4	AC3/FP3	AC2/FP2	AC1/FP1	AC0/FP0
	W	BFP7	BFP6	BFP5	BFP4	BFP3	BFP2	BFP1	BFP0
Reset		0	0	0	0	0	1	0	0

For Frequency Compensation procedure, please refer to AMICCOM's reference code and contact AMICCOM FAE team for details.

### 15. Calibration

A7105 needs calibration process during initialization with 3 calibration items, they are, VCO Current, VCO Bank, and IF Filter Bank.

1. VCO Current Calibration (Standby or PLL mode) is used to find adequate VCO current.
2. VCO Bank Calibration (PLL mode) is used to select best VCO frequency bank for the calibrated frequency.
3. IF Filter Bank Calibration (Standby or PLL mode) is used to calibrate IF filter bandwidth and center frequency.

#### 15.1 Calibration Procedure

1. Initialize all control registers (refer to A7105 reference code).
2. Select auto value mode (set MFBS, MVCS, MVBS = 0).
3. Set A7105 in PLL mode.
4. Enable IF Filter Bank (set FBC = 1) and Enable VCO Current, Bank and Deviation Calibration (VCC, VBC = 1).
5. After calibration done, FBC, VCC and VBC is auto clear.
6. Check pass or fail by calibration flag. (FBCF) and (VCCF, VBCF).

#### 15.2 IF Filter Bank Calibration

##### Relative Control Register

Calibration Control Register (Address: 02h)

Name	R/W	Bit 7	Bit 6	Bit 5	Bit 4	Bit 3	Bit 2	Bit 1	Bit 0
Mode Control II	W/R	--	--	--	--	--	VCC	VBC	FBC
Reset		--	--	--	--	--	0	0	0

IF Calibration Register I (Address: 22h)

Name	R/W	Bit 7	Bit 6	Bit 5	Bit 4	Bit 3	Bit 2	Bit 1	Bit 0
IF Calibration I	R				FBCF	FB3	FB2	FB1	FB0
	W	--	--	--	MFBS	MFB3	MFB2	MFB1	MFB0
Reset		--	--	--	0	0	1	1	0

1. Initialize all control registers (refer to A7105 reference code).
2. Set MFBS = 0 for auto calibration.
3. Set A7105 in PLL mode.
4. Set FBC= 1 (02h).
5. The maximum calibration time for this calibration is about 256us.
6. FBC is auto clear after calibration done.
7. User can read calibration flag (FBCF, 22h) to check pass or fail.
8. User also can read FB [3:0] (22h) to get the auto calibration value.

#### 15.3 VCO Current Calibration

##### Relative Control Register

Calibration Control Register (Address: 02h)

Name	R/W	Bit 7	Bit 6	Bit 5	Bit 4	Bit 3	Bit 2	Bit 1	Bit 0
Mode Control II	W/R	--	--	--	--	--	VCC	VBC	FBC

Reset		--	--	--	--	--	0	0	0
-------	--	----	----	----	----	----	---	---	---

VCO current Calibration Register (Address: 24h)

Name	R/W	Bit 7	Bit 6	Bit 5	Bit 4	Bit 3	Bit 2	Bit 1	Bit 0
VCO current Calibration	R				FVCC	VCB3	VCB2	VCB1	VCB0
	W	--	--	VCCS	<b>MVCS</b>	VCOC3	VCOC2	VCOC1	VCOC0
Reset		--	--	0	0	1	0	0	0

1. Initialize all control registers (refer A7105 reference code).
2. Set MVCS= 0 for auto calibration.
3. Set A7105 in PLL mode.
4. Set VCC = 1 (02h).
5. VCC is auto clear after calibration done.
6. User can read calibration flag (VCCF, 24h) to check pass or fail.
7. User can read VCB [3:0] (24h) to get the auto calibration value.

### 15.4 VCO Bank Calibration

#### Relative Control Register

Calibration Control Register (Address: 02h)

Name	R/W	Bit 7	Bit 6	Bit 5	Bit 4	Bit 3	Bit 2	Bit 1	Bit 0
Mode Control II	W/R	--	--	--	--	--	<b>VCC</b>	<b>VBC</b>	<b>FBC</b>
Reset		--	--	--	--	--	0	0	0

VCO Single band Calibration Register I (Address: 25h)

Name	R/W	Bit 7	Bit 6	Bit 5	Bit 4	Bit 3	Bit 2	Bit 1	Bit 0
VCO Single band Calibration I	R	--	--	DVT1	DVT0	VBCF	VB2	VB1	VB0
	W	--	--	--	--	<b>MVBS</b>	MVB2	MVB1	MVB0
Reset		--	--	--	--	0	1	0	0

VCO Single band Calibration Register II (Address: 26h)

Name	R/W	Bit 7	Bit 6	Bit 5	Bit 4	Bit 3	Bit 2	Bit 1	Bit 0
VCO Single band Calibration II	W	--	--	VTH2	VTH1	VTH0	VTL2	VTL1	VTL0
Reset		--	--	1	1	1	0	1	1

1. Initialize all control registers (refer to A7105 reference code).
2. Set MVBS= 0 for auto calibration.
3. Set A7105 in PLL mode.
4. Set VBC= 1 (02h). Set VCO tuning upper threshold voltage VH and lower threshold voltage VL. The recommended voltage is VTH = 6 (VH = 0.9), VTL = 3 (VL = 0.4), if internal regulator is set to 2.1V.
5. The maximum calibration time for VCO Bank Calibration is about 240 us (4 \* PLL settling time).
6. VBC is auto clear after calibration done.
7. User can read calibration flag (VBCF, 25h) to check pass or fail.
8. User can read VB [2:0] (25h) to get the auto calibration value.

**16. FIFO (First In First Out)**

A7105 supports separated 64-bytes TX and RX FIFO by enabling FMS =1 (01h). For FIFO accessing, TX FIFO (write-only) and RX FIFO (read-only) share the same register address 05h. TX FIFO represents transmitted payload. On the other hand, once RX circuitry synchronizes ID Code, received payload is stored into RX FIFO.

In chapter 10 and 11, user can also find listed FIFO information below.

- (1) Figure 10.15 and 10.16 for FIFO accessing via 3-wire SPI.
- (2) Section 10.4.7 and 10.4.8 for FIFO pointer reset command.
- (3) Figure 11.2 and Figure 11.3 for Normal/Quick FIFO mode.

**16.1 Packet Format**

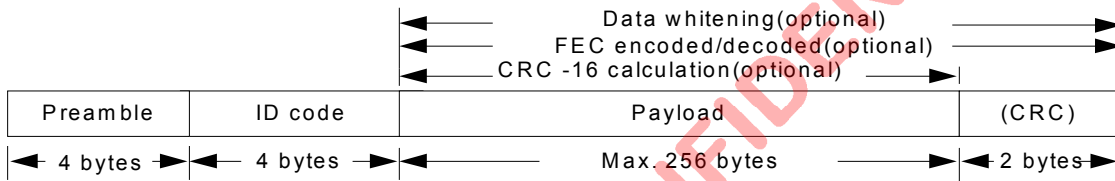

Figure 16.1 Packet Format of FIFO mode

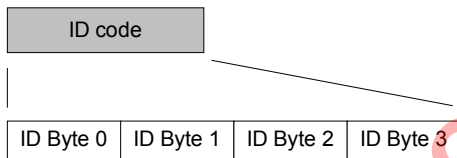

Figure 16.2 ID Code Format

**Preamble:**

The packet is led by preamble composed of alternate 0 and 1. If the first bit of ID code is 0, preamble shall be 0101...0101. In the contrast, if the first bit of ID code is 1, preamble shall be 1010...1010. Preamble length is recommended to set 4 bytes by PML [1:0] (1Fh).

**ID code:**

ID code is recommended to set 4 bytes by IDL=1 (1Fh). ID Code is sequenced by Byte 0, 1, 2 and 3. If RX circuitry checks the ID code correct, received payload will be stored into RX FIFO. In special case, ID code could be set error tolerance (0~ 3bit error) by ETH [1:0] (20h) for ID synchronization check.

**Payload:**

Payload length is programmable by FEP [7:0] (03h). The physical FIFO depth is 64 bytes. A7105 also supports logical FIFO extension up to 256 bytes. See section 16.5 for details.

**CRC (option):**

In FIFO mode, if CRC is enabled (CRCS=1, 1Fh), 2-bytes of CRC value is transmitted automatically after payload. In the same way, RX circuitry will check CRC value and show the result to CRC Flag (00h).

### Relative Control Register

Mode Register (Address: 00h)

Name	R/W	Bit 7	Bit 6	Bit 5	Bit 4	Bit 3	Bit 2	Bit 1	Bit 0
Mode	R	--	FECF	CRCF	CER	XER	PLLER	TRSR	TRER
	W	RESETN	RESETN	RESETN	RESETN	RESETN	RESETN	RESETN	RESETN
Reset		--	--	--	--	--	--	--	--

FIFO Register I (Address: 03h)

Bit	R/W	Bit 7	Bit 6	Bit 5	Bit 4	Bit 3	Bit 2	Bit 1	Bit 0
Name	W	FEP7	FEP6	FEP5	FEP4	FEP3	FEP2	FEP1	FEP0
Reset		0	0	1	1	1	1	1	1

Code Register I (Address: 1Fh)

Name	R/W	Bit 7	Bit 6	Bit 5	Bit 4	Bit 3	Bit 2	Bit 1	Bit 0
Code I	W	--	MCS	WHTS	FECS	CRCS	IDL	PML1	PML0
Reset		--	0	0	0	0	1	1	1

Code Register II (Address: 20h)

Name	R/W	Bit 7	Bit 6	Bit 5	Bit 4	Bit 3	Bit 2	Bit 1	Bit 0
Code II	W	--	DCL2	DCL1	DCL0	ETH1	ETH0	PMD1	PMD0
Reset		--	1	1	1	0	1	1	1

Code Register III (Address: 21h)

Name	R/W	Bit 7	Bit 6	Bit 5	Bit 4	Bit 3	Bit 2	Bit 1	Bit 0
Code III	W	--	WS6	WS5	WS4	WS3	WS2	WS1	WS0
Reset		--	0	1	0	1	0	1	0

### 16.2 Bit Stream Process

A7105 supports 3 optional bit stream process for payload, they are,

- (1) CCITT-16 CRC
- (2) (7, 4) Hamming FEC
- (3) Data Whitening by XOR PN7 (7-bits Pseudo Random Sequence).

#### CRC (Cyclic Redundancy Check):

- CRC is enabled by CRCS= 1 (1Fh). TX circuitry calculates the CRC value of payload (preamble, ID code excluded) and transmits 2-bytes CRC value after payload.
- RX circuitry checks CRC value and shows the result to CRC Flag (00h). If CRCF=0, received payload is correct, else error occurred. (CRCF is read only, it is revised internally while receiving every packet.)

#### FEC (Forward Error Correction):

- FEC is enabled by FECS= 1 (1Fh). Payload and CRC value (if CRCS=1) are encoded by (7, 4) Hamming code.
- Each 4-bits (nibble) of payload is encoded into 7-bits code word and delivered out automatically.  
(ex. 64 bytes payload will be encoded to 128 code words, each code word is 7 bits.)
- RX circuitry decodes received code words automatically. FEC supports 1-bit error correction each code word. Once 1-bit error occurred, FEC flag=1 (00h). (FECF is read only, it is revised internally while receiving every packet.)

#### Data Whitening:

- Data whitening is enabled by WHTS= 1 (1Fh). The initial seed of PN7 is WS [6:0] (22h). Payload is always encrypted by bit XOR operation with PN7. CRC and/or FEC are also encrypted if CRCS=1 and/or if FECS=1.

- RX circuitry decrypts received payload and 2-bytes CRC (if CRCS=1) automatically. Be notice, user shall set the same WS [6:0] (21h) to TX and RX.

**16.3 Transmission Time**

Based on CRC and FEC options, the transmission time are different. See table 16.1 for details.

Data Rate = 500 Kbps

Data Rate (Kbps)	Preamble (bits)	ID Code (bits)	Payload (bits)	CRC (bits)	FEC	Transmission Time / Packet
500	32	32	512	Disable	Disable	576 bit X 2 us = 1.152 ms
500	32	32	512	16 bits	Disable	592 bit X 2 us = 1.184 ms
500	32	32	512	Disable	512 x 7 / 4	960 bit X 2 us = 1.920 ms
500	32	32	512	16 x 7 / 4	512 x 7 / 4	988 bit X 2 us = 1.976 ms

Data Rate = 250 Kbps

Data Rate (Kbps)	Preamble (bits)	ID Code (bits)	Payload (bits)	CRC (bits)	FEC	Transmission Time / Packet
250	32	32	512	Disable	Disable	576 bit X 4 us = 2.304 ms
250	32	32	512	16 bits	Disable	592 bit X 4 us = 2.368 ms
250	32	32	512	Disable	512 x 7 / 4	960 bit X 4 us = 3.840 ms
250	32	32	512	16 x 7 / 4	512 x 7 / 4	988 bit X 4 us = 3.952 ms

Data Rate = 125 Kbps

Data Rate (Kbps)	Preamble (bits)	ID Code (bits)	Payload (bits)	CRC (bits)	FEC	Transmission Time / Packet
125	32	32	512	Disable	Disable	576 bit X 8 us = 4.608 ms
125	32	32	512	16 bits	Disable	592 bit X 8 us = 4.736 ms
125	32	32	512	Disable	512 x 7 / 4	960 bit X 8 us = 7.580 ms
125	32	32	512	16 x 7 / 4	512 x 7 / 4	988 bit X 8 us = 7.904 ms

Data Rate = 50 Kbps

Data Rate (Kbps)	Preamble (bits)	ID Code (bits)	Payload (bits)	CRC (bits)	FEC	Transmission Time / Packet
50	32	32	512	Disable	Disable	576 bit X 20 us = 11.52 ms
50	32	32	512	16 bits	Disable	592 bit X 20 us = 11.84 ms
50	32	32	512	Disable	512 x 7 / 4	960 bit X 20 us = 19.20 ms
50	32	32	512	16 x 7 / 4	512 x 7 / 4	988 bit X 20 us = 19.76 ms

Data Rate = 2 Kbps

Data Rate (Kbps)	Preamble (bits)	ID Code (bits)	Payload (bits)	CRC (bits)	FEC	Transmission Time / Packet
2	32	32	512	Disable	Disable	576 bit X 0.5 ms = 0.288 s
2	32	32	512	16 bits	Disable	592 bit X 0.5 ms = 0.296 s
2	32	32	512	Disable	512 x 7 / 4	960 bit X 0.5 ms = 0.480 s
2	32	32	512	16 x 7 / 4	512 x 7 / 4	988 bit X 0.5 ms = 0.494 s

Table 16.1 Transmission time table



### 16.4 Usage of TX and RX FIFO

In application points of view, A7105 supports 3 options of FIFO arrangement.

- (1) Easy FIFO
- (2) Segment FIFO
- (3) FIFO Extension

For FIFO operation, A7105 supports Strobe command to reset TX and RX FIFO pointer as shown below. User can refer to section 10.5 for FIFO write pointer reset and FIFO read pointer reset.

#### Strobe Command

Strobe Command								Description
A7	A6	A5	A4	A3	A2	A1	A0	
1	1	1	0	x	x	X	x	FIFO write pointer reset (for TX FIFO)
1	1	1	1	x	x	X	x	FIFO read pointer reset (for RX FIFO)

FIFO Register I (Address: 03h)

Bit	R/W	Bit 7	Bit 6	Bit 5	Bit 4	Bit 3	Bit 2	Bit 1	Bit 0
Name	W	FEP7	FEP6	FEP5	FEP4	FEP3	FEP2	FEP1	FEP0
Reset		0	0	1	1	1	1	1	1

FIFO Register II (Address: 04h)

Bit	R/W	Bit 7	Bit 6	Bit 5	Bit 4	Bit 3	Bit 2	Bit 1	Bit 0
Name	W	FPM1	FPM0	PSA5	PSA4	PSA3	PSA2	PSA1	PSA0
Reset		0	1	0	0	0	0	0	0

FIFO DATA Register (Address: 05h)

Bit	R/W	Bit 7	Bit 6	Bit 5	Bit 4	Bit 3	Bit 2	Bit 1	Bit 0
Name	R/W	FIFO7	FIFO6	FIFO5	FIFO4	FIFO3	FIFO2	FIFO1	FIFO0
Reset		0	0	0	0	0	0	0	0

#### 16.4.1 Easy FIFO

In Easy FIFO, max FIFO length is 64 bytes. FIFO length is equal to **(FEP [7:0] + 1)**. User just needs to control FEP [7:0] (03h) and disable PSA and FPM as shown below.

Register setting

TX	RX	Control Registers		
FIFO Length (byte)	FIFO Length (byte)	FEP[7:0] (03h)	PSA [5:0] (04h)	FPM [1:0] (04h)
1	1	0x00	0	0
8	8	0x07	0	0
16	16	0x0F	0	0
32	32	0x1F	0	0
64	64	0x3F	0	0

Table 16.2 Control registers of Easy FIFO

**Procedures of TX FIFO Transmitting**

1. Initialize all control registers (refer to A7105 reference code).
2. Set FEP [7:0] = 0x3F for 64-bytes FIFO.
3. Refer to Figure 11.2 and Figure 11.3
4. Send Strobe command – TX FIFO write pointer reset.
5. MCU writes 64-bytes data to TX FIFO.
6. Send TX Strobe Command.
7. Done.

**Procedures of RX FIFO Reading**

1. When RX FIFO is full, WTR (or FSYNC) can be used to trigger MCU for RX FIFO reading.
2. Send Strobe command – RX FIFO read pointer reset.
3. MCU read 64-bytes from RX FIFO.
4. Done.

**Definitions**

**DP** : Deliver Pointer  
**RP** : Received Pointer

**TX FIFO Empty** = DP reaches FEP[7:0]  
**RX FIFO FULL** = RP reaches FEP[7:0]

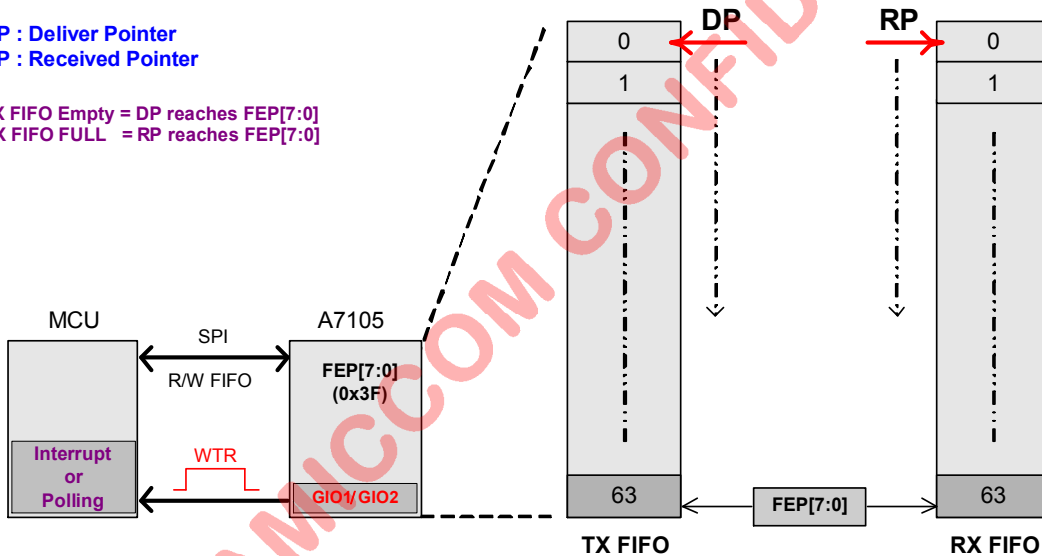

Figure 16.3 Easy FIFO

**16.4.2 Segment FIFO**

In Segment FIFO, TX FIFO length is equal to (FEP [7:0] – PSA [5:0] + 1). FPM [1:0] should be zero. This function is very useful for button applications. In such case, each button is used to transmit fixed code (data) every time. During initialization, each fixed code is written into corresponding segment FIFO once and for all. Then, if button is triggered, MCU just assigns corresponding segment FIFO (PSA [5:0] and FEP [7:0]) and issues TX strobe command.

If TX FIFO is arranged into 8 segments, each TX segment and RX FIFO length are 8 bytes

TX				Control Registers		
Segment	PSA	FEP	FIFO Length (byte)	PSA[5:0] (04h)	FEP[7:0] (03h)	FPM[1:0] (04h)
1	PSA1	FEP1	8	0x00	0x07	0
2	PSA2	FEP2	8	0x08	0x0F	0

3	PSA3	FEP3	8	0x10	0x17	0
4	PSA4	FEP4	8	0x18	0x1F	0
5	PSA5	FEP5	8	0x20	0x27	0
6	PSA6	FEP6	8	0x28	0x2F	0
7	PSA7	FEP7	8	0x30	0x37	0
8	PSA8	FEP8	8	0x38	0x3F	0

RX	Control Registers		
FIFO Length (byte)	PSA [5:0] (04h)	FEP [7:0] (03h)	FPM[1:0] (04h)
8	0	0x07	0

Table 16.3 Segment FIFO is arranged into 8 segments

**Procedures of TX FIFO Transmitting**

1. Initialize all control registers (refer A7105 reference code).
2. Refer to Figure 11.2 and Figure 11.3 (in chapter 11).
3. Send Strobe command – TX FIFO write pointer reset.
4. MCU writes fixed code into corresponding segment FIFO once and for all.
5. To consign Segment 1, set PSA = 0x00 and FEP= 0x07  
 To consign Segment 2, set PSA = 0x08 and FEP= 0x0F  
 To consign Segment 3, set PSA = 0x10 and FEP= 0x17  
 To consign Segment 4, set PSA = 0x18 and FEP= 0x1F  
 To consign Segment 5, set PSA = 0x20 and FEP= 0x27  
 To consign Segment 6, set PSA = 0x28 and FEP= 0x2F  
 To consign Segment 7, set PSA = 0x30 and FEP= 0x37  
 To consign Segment 8, set PSA = 0x38 and FEP= 0x3F
6. Send TX Strobe Command.
7. Done.

**Procedures of RX FIFO Reading**

1. When RX FIFO is full, WTR (or FSYNC) is used to trigger MCU for RX FIFO reading.
2. Send Strobe command – RX FIFO read pointer reset.
3. MCU read 8-bytes from RX FIFO.
4. Done.

AMICCOM CONFIDENTIAL

**Definitions**

**DP** : Deliver Pointer  
**RP** : Received Pointer

**TX FIFO Empty** = DP reaches FEP[7:0]  
**RX FIFO FULL** = RP reaches FEP[7:0]

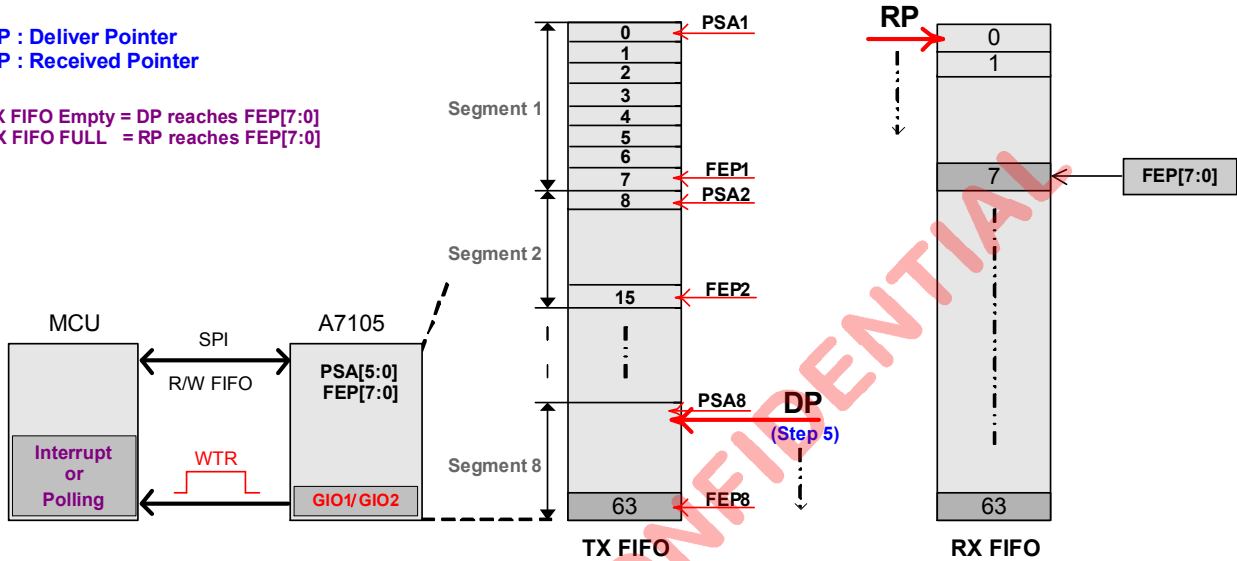

Figure 16.4 Segment FIFO Mode

**16.4.3 FIFO Extension**

In FIFO Extension, A7105 provide configurable FIFO threshold by setting FPM [1:0] in FIFO control register. FPM [1:0] is used to set FIFO Pointer Flag (FPF) to trigger MCU. FIFO pointer Flag (FPF) can be output to pin CKO by set CKOS = 2 (0AH). Refer Table 16.5 for FIFO Pointer Flag (FPF) threshold value.

In TX mode, when the result of WP (write pointer) subtracting RP (read pointer) is equal or less than the value set by FPM [1:0], FPF is 1. Otherwise it is 0.

In RX mode, when the result of WP (write pointer) subtracting RP (read pointer) is larger than the value set by FPM [1:0], FPF is 1. Otherwise it is 0.

DP is Delivering Pointer and WTX is TX-FIFO Write Pointer.

FPM [1:0]	Bytes in TX FIFO	Bytes in RX FIFO	FPF = 1 (CKO pin)	Note
[00]	4	60	WTX – DP <= 4	FPF=1, when delivering 60 <sup>th</sup> byte
[01]	8	56	WTX – DP <= 8	FPF=1, when delivering 56 <sup>th</sup> byte
[10]	12	52	WTX – DP <= 12	FPF=1, when delivering 52 <sup>th</sup> byte
[11]	16	48	WTX – DP <= 16	FPF=1, when delivering 48 <sup>th</sup> byte

RP is Receiving Pointer and RRX is RX-FIFO Read Pointer.

FPM [1:0]	Bytes in TX FIFO	Bytes in RX FIFO	FPF = 1 (CKO pin)	Note
[00]	4	60	RP – RRX > 60	FPF=1, when receiving 60 <sup>th</sup> byte
[01]	8	56	RP – RRX > 8	FPF=1, when receiving 56 <sup>th</sup> byte
[10]	12	52	RP – RRX > 12	FPF=1, when receiving 52 <sup>th</sup> byte
[11]	16	48	RP – RRX > 16	FPF=1, when receiving 48 <sup>th</sup> byte

Table 16.4 FIFO point Flag threshold value.

A7105 could handle data package set up to 256 bytes by FEP [7:0] with different FPF trigger conditions. Be notice, setting of SPI data rate is important to prevent error operation of FIFO extension. The min. SPI data rate shall be equal or greater than **(A105 data rate + 500Kbps)**

**Procedures of TX FIFO Extension**

1. Initialize all control registers (refer A7105 reference code).
2. Set FEP [7:0] = 0xFF for 256-bytes FIFO extension.
3. Set FPM [1:0] = 11 for FPF trigger condition.
4. Refer to Figure 11.2, Figure 11.3 and Figure 16.5 TX FIFO Extension.
5. Send Strobe command – TX FIFO write pointer reset.
6. MCU writes 1<sup>st</sup> 64-bytes TX FIFO.
7. Send TX Strobe command.
8. MCU monitors FPF from A7105.
9. FPF triggers MCU to write 2<sup>nd</sup> 64-bytes TX FIFO.
10. MCU monitors FPF from A7105.
11. FPF triggers MCU to write 3<sup>rd</sup> 64-bytes TX FIFO.
12. MCU monitors FPF from A7105.
13. FPF triggers MCU to write 4<sup>th</sup> 64-bytes TX FIFO.
14. Done.

**Definitions**

- DP : Deliver Pointer**
- RP : Received Pointer**
- WTX : Write TX FIFO Pointer**
- Delta : WTX-DP+1 = 16 if FPM=11**

TX FIFO Empty = DP reaches FEP[7:0]  
 RX FIFO FULL = RP reaches FEP[7:0]

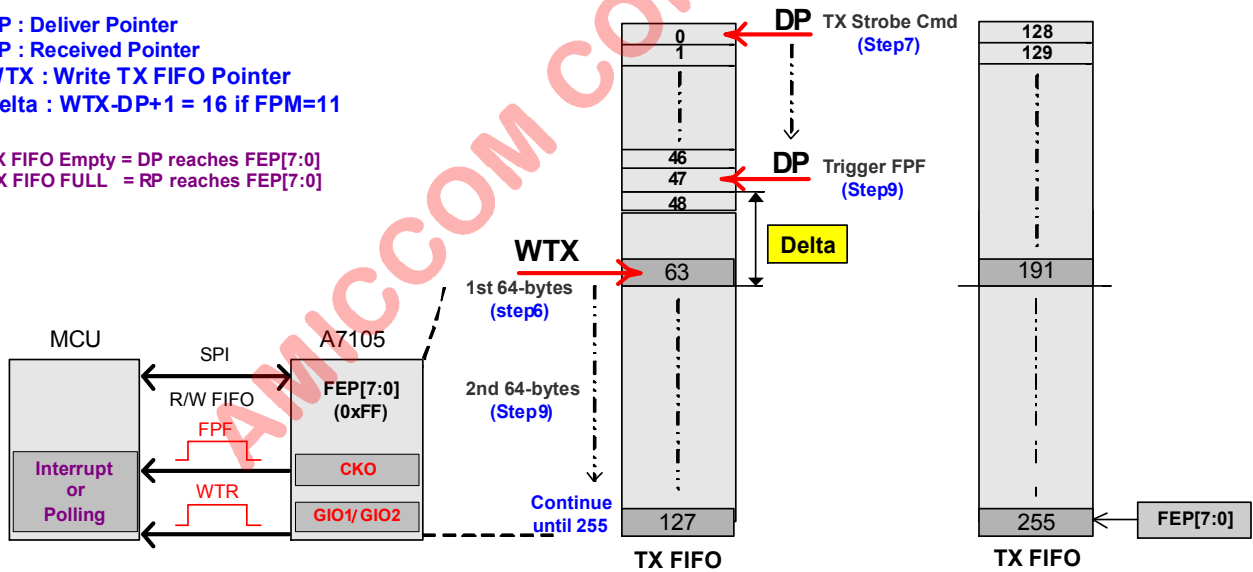

Figure 16.5 TX FIFO Extension

**Procedures of RX FIFO Reading**

1. Initialize all control registers (refer A7105 reference code).
2. Set FEP [7:0] = 0xFF for 256-bytes FIFO extension.
3. Set FPM [1:0] = 11 for FPF trigger condition.
4. Refer to Figure 11.2, Figure 11.3 and Figure 16.6 RX FIFO Extension.
5. Send Strobe command – RX FIFO read pointer reset.
6. Send RX Strobe command.
7. MCU monitors FPF from A7105.
8. FPF triggers MCU to read 1<sup>st</sup> 64-bytes RX FIFO.
9. MCU monitors FPF from A7105.
10. FPF triggers MCU to read 2<sup>nd</sup> 64-bytes RX FIFO.
11. MCU monitors FPF from A7105.
12. FPF triggers MCU to read 3<sup>rd</sup> 64-bytes RX FIFO.
13. MCU monitors FPF from A7105.
14. FPF triggers MCU to read 4<sup>th</sup> 64-bytes RX FIFO.
15. Done.

**Definitions**

**DP** : Deliver Pointer  
**RP** : Received Pointer  
**RRX** : Read FIFO Pointer  
**Delta** :  $RP - RRX + 1 = 48$  if  $FPM = 11$

TX FIFO Empty = DP reaches FEP[7:0]  
 RX FIFO FULL = RP reaches FEP[7:0]

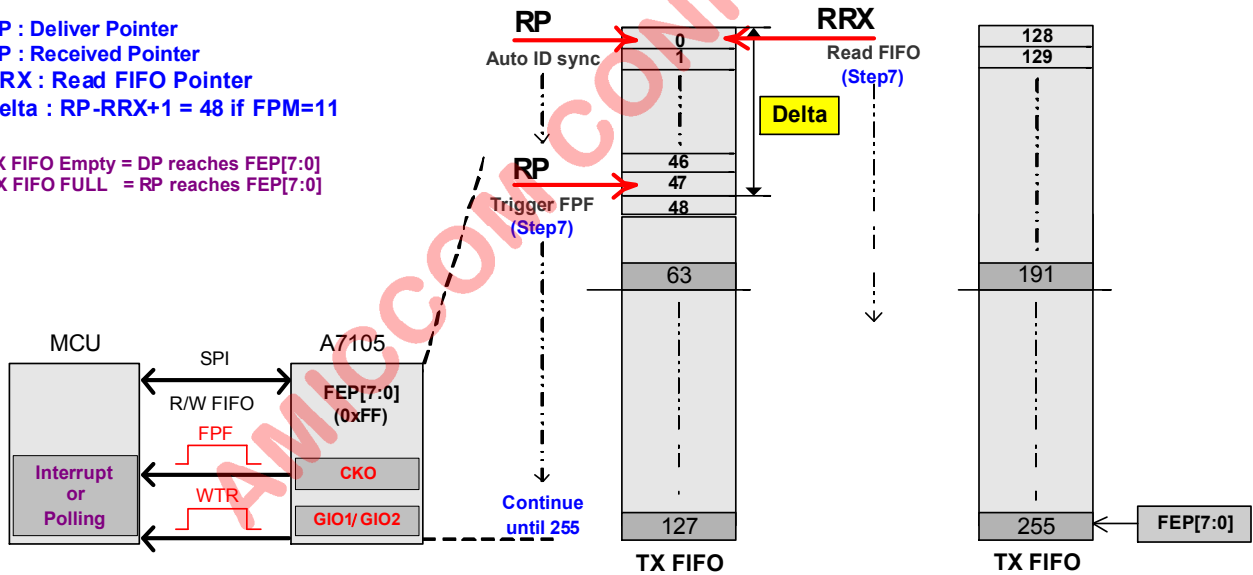

Figure 16.6 RX FIFO Extension Mode

**17. ADC (Analog to Digital Converter)**

A7105 has built-in 8-bits ADC do RSSI measurement as well as carrier detection function. User can set FSARS (1Eh) to select 4MHz or 8MHz ADC clock (F<sub>ADC</sub>). The converting time is 8 x 20 x ADC clock periods. FSARS = 0 (F<sub>ADC</sub> =4MHz) is recommended to save power.

Bit		Description	
XADS	RSS	Standby mode	RX mode
0	0	Reserved	None
0	1	None	RSSI / Carrier detect
1	X	Reserved	None

Table 17.1 Setting of ADC function

**Relative Control Register**

Mode Control Register (Address: 01h)

Bit	R/W	Bit 7	Bit 6	Bit 5	Bit 4	Bit 3	Bit 2	Bit 1	Bit 0
Name	R	DDPC	ARSSI	AIF	CD	WWSE	FMT	FMS	ADCM
	W	DDPC	ARSSI	AIF	DFCD	WWSE	FMT	FMS	ADCM
Reset		0	0	0	0	0	0	0	0

RSSI Threshold Register (Address: 1Dh)

Name	R/W	Bit 7	Bit 6	Bit 5	Bit 4	Bit 3	Bit 2	Bit 1	Bit 0
RSSI Threshold	R	ADC7	ADC6	ADC5	ADC4	ADC3	ADC2	ADC1	ADC0
	W	RTH7	RTH6	RTH5	RTH4	RTH3	RTH2	RTH1	RTH0
Reset		1	0	0	1	0	0	0	1

ADC Control Register (Address: 1Eh)

Name	R/W	Bit 7	Bit 6	Bit 5	Bit 4	Bit 3	Bit 2	Bit 1	Bit 0
ADC Control	W	RSM1	RSM0	ERSS	FSARS	--	XADS	RSS	CDM
Reset		0	1	0	1	--	0	1	1

**17.1 RSSI Measurement**

A7105 has built-in 8-bits digital RSSI to detect RF signal strength. After measurement done, RSSI is stored in ADC [7:0] (1Dh). The more signal power, the smaller RSSI value.

Below is the measurement procedure:

**Auto RSSI measurement for TX Power:**

1. Set wanted F<sub>RxLO</sub> (Refer to chapter 14).
2. Set RSS= 1 (1Eh), FSARS= 0 (1Eh).
3. Set ARSSI= 1 (01h).
4. Send RX Strobe command.
5. Once entering into RX mode, A7105 executes 8-times average measurement repeatedly.
6. Once receiving packet and leaves RX mode, user can read digital RSSI value from ADC [7:0] (1Dh) for TX power.

Be notice, in step 6, if A7105 is set in direct mode, once the received packet is completed, MCU shall ask A7105 to leave RX mode within 40 us to prevent RSSI inaccuracy. The curve for RSSI vs. input power is negative slope. That means the smaller ADC value the larger input power.

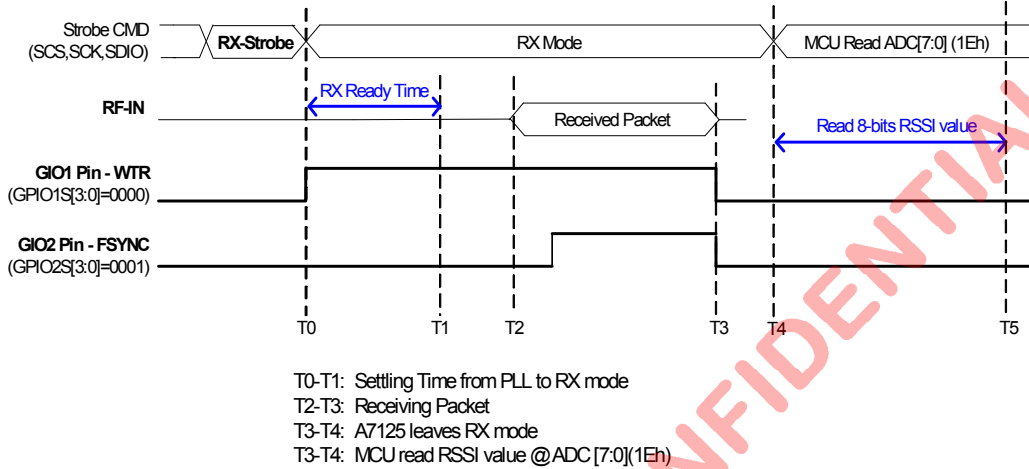

Figure 17.1 Timing chart of Auto RSSI measurement for TX Power:

**Auto RSSI measurement for Background Power:**

1. Set wanted  $F_{RXLO}$  (Refer to chapter 14).
2. Set RSS= 1 (1Eh), FSARS= 0 (1Eh).
3. Set ARSSI= 1 (01h).
4. Send RX Strobe command.
5. MCU delays min. 300us.
6. MCU disable ARSSI = 0 (01h).
7. Read digital RSSI value from ADC [7:0] (1Dh) to get background power.
8. Send Strobe command to ask A7105 to leave RX mode.

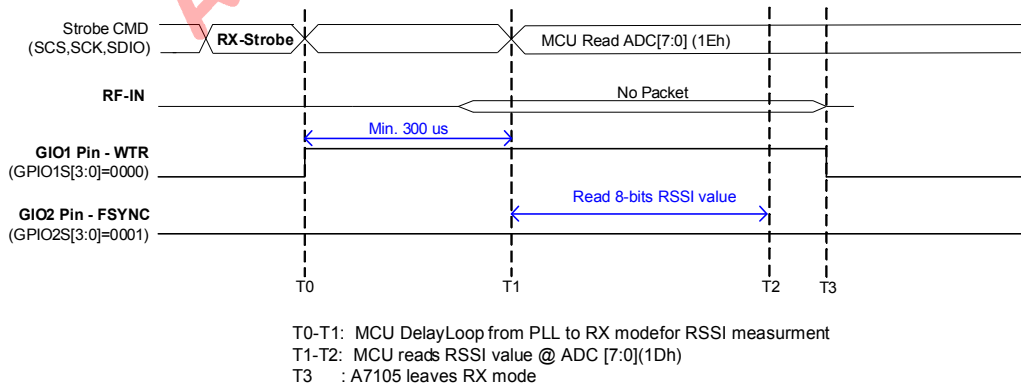

Figure 17.2 Timing chart of Auto RSSI measurement for Background Power:



**17.2 Carrier Detect**

Base on RSSI measurement, user can extend its application to do carrier detect (CD). If CD is triggered, it is output to GIO1 or GIO2 pin to inform MCU occupied channel.

Below is the detection procedure:

1. Set RTH (1Dh) for RSSI higher threshold by user's definition.
2. Recommend to set RSM = [11] (1Eh) to get RSSI lower threshold,  $RTL = RTH + RSM$ .
3. Set GIO1S = [0010] (0Bh) for GIO1 pin to output CD signal.
4.
  - (4-1) Set wanted  $F_{RXLO}$  (Refer to chapter 14).
  - (4-2) Set RSS= 1 (Enable RSSI, 1Eh), FSARS= 0 ( $F_{ADC} = 4MHz1Eh$ ).
  - (4-3) Set ARSSI= 1 (Enable Auto RSSI, 01h).
  - (4-4) RX Strobe command (In RX mode).
  - (4-5) MCU enables time out timer (min. 300 us).
5. MCU checks GIO1 pin for carrier detect (CD) signal until time out.
6. Leave RX mode.

Be notice,

In step 5, CD=1, this channel is occupied. ( $RSSI \leq RTH$ )  
 CD=0, this channel is clear. ( $RSSI \geq RTH$ )

**18. Battery Detect**

A7105 has built-in battery detector to check supply voltage (REGI pin). The detect range is 2.0V ~ 2.7V in 8 levels.

**Relative Control Register**

Battery detect Register (Address: 27h)

Name	R/W	Bit 7	Bit 6	Bit 5	Bit 4	Bit 3	Bit 2	Bit 1	Bit 0
Battery detect	R	--	--	--	BDF	--	--	--	--
	W	RGS	RGV1	RGV0	--	BVT2	BVT1	BVT0	BD_E
Reset		0	0	0	--	0	1	1	0

**BVT [2:0]: Battery voltage detect threshold.**  
**[000]:** 2.0V. **[001]:** 2.1V. **[010]:** 2.2V. **[011]:** 2.3V.  
**[100]:** 2.4V. **[101]:** 2.5V. **[110]:** 2.6V. **[111]:** 2.7V.

Below is the procedure to detect low voltage input (ex. below 2.1V):

1. Set A7105 in standby or PLL mode.
2. Set BVT (27h) = [001] and enable BD\_E (27h) = 1.
3. After 5 us, BD\_E is auto clear.
4. MCU check BDF (27h).  
 If REGI pin > 2.1V,  
 BDF = 1. Else, BDF = 0.

**19 TX power setting**

TX test register (28h) is used to program TX power. The following tables show the typical TX power vs. current in different register values.

**For PAC = 3:**

TBG	0	1	2	3	4	5	6	7
TX output (dBm)	-17.6	-14.5	-10	-7.2	-5.1	-3.5	-0.5	1.3
Current (mA)	17.6	17.7	17.78	18.1	18.2	18,5	19.5	21.25

**For PAC = 2:**

TBG	0	1	2	3	4	5	6	7
TX output (dBm)	-18.7	-15.2	-12	-8.54	-6.84	-4.77	-1.5	0.1
Current (mA)	15.3	15.4	15.5	15.8	16.1	16.5	17.6	19

**For PAC = 1:**

TBG	0	1	2	3	4	5	6	7
TX output (dBm)	-20.7	-16.9	-13.8	-10.4	-8.3	-6.3	-3.4	-0.5
Current (mA)	13.4	13.5	13.7	13.9	14.3	14.5	15.9	18

**For PAC = 0:**

TBG	0	1	2	3	4	5	6	7
TX output (dBm)	-23.3	-19.2	-16.6	-13.2	-10.9	-8.9	-4.8	-2.0
Current (mA)	12.4	12.5	12.6	12.9	13.3	13.6	14.9	16.9

For 0 dBm TX output power, the register setting: PAC = 2 and TBG = 7 are recommended.

For -10 dBm TX output power (low current requirement), PAC = 1 and TBG = 3 is recommended.



**21. Abbreviations**

ADC	Analog to Digital Converter
AIF	Auto IF
FC	Frequency Compensation
AGC	Automatic Gain Control
BER	Bit Error Rate
BW	Bandwidth
CD	Carrier Detect
CHSP	Channel Step
CRC	Cyclic Redundancy Check
DC	Direct Current
FEC	Forward Error Correction
FIFO	First in First out
FSK	Frequency Shift Keying
ID	Identifier
IF	Intermediate Frequency
ISM	Industrial, Scientific and Medical
LO	Local Oscillator
MCU	Micro Controller Unit
PFD	Phase Frequency Detector for PLL
PLL	Phase Lock Loop
POR	Power on Reset
RX	Receiver
RXLO	Receiver Local Oscillator
RSSI	Received Signal Strength Indicator
SPI	Serial to Parallel Interface
SYCK	System Clock for digital circuit
TX	Transmitter
TXRF	Transmitter Radio Frequency
VCO	Voltage Controlled Oscillator
XOSC	Crystal Oscillator
XREF	Crystal Reference frequency
XTAL	Crystal

AMICCOM CONFIDENTIAL

**22. Ordering Information**

Part No.	Package	Units Per Reel / Tray
A71X05AQFI/Q	QFN20L, Pb Free, Tape & Reel, -40°C ~ 85°C	3K
A71X05AQFI	QFN20L, Pb Free, Tray, -40°C ~ 85°C	490EA
A71X05BH	Die form, -40°C ~ 85°C	100EA

### 23. Package Information

QFN 20L (4 X 4 X 0.8mm) Outline Dimensions

unit: inches/mm

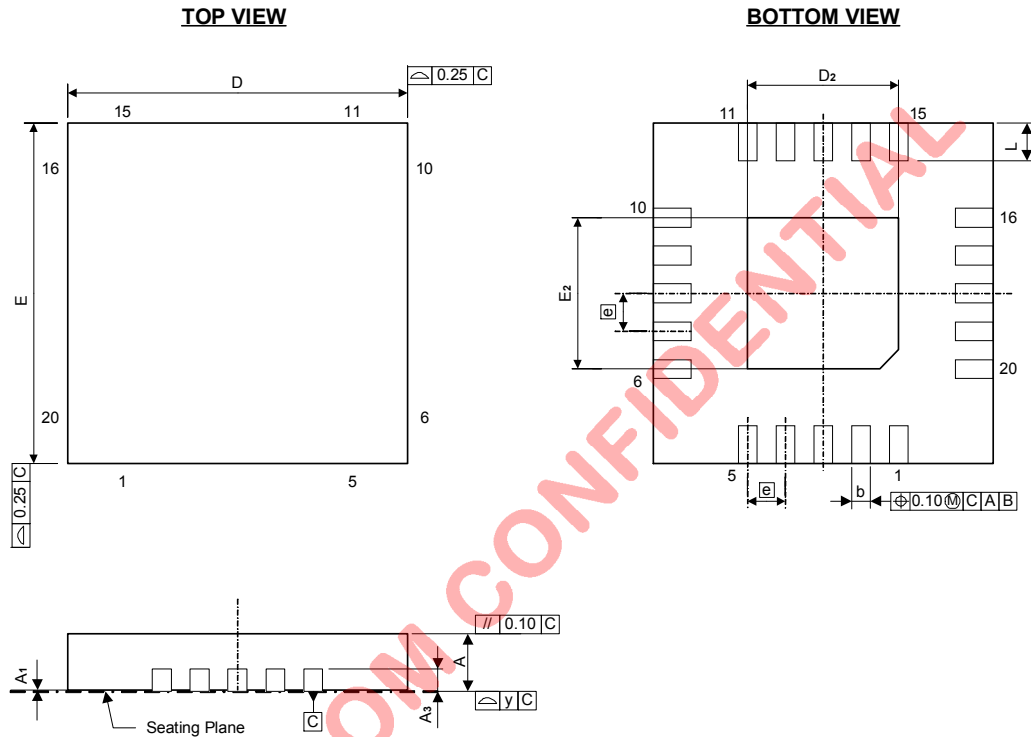

Symbol	Dimensions in inches			Dimensions in mm		
	Min	Nom	Max	Min	Nom	Max
A	0.028	0.030	0.032	0.70	0.75	0.80
A1	0.000	0.001	0.002	0.00	0.02	0.05
A3	0.008 REF			0.203 REF		
b	0.007	0.010	0.012	0.18	0.25	0.30
D	0.154	0.158	0.161	3.90	4.00	4.10
D2	0.075	0.079	0.083	1.90	2.00	2.10
E	0.154	0.158	0.161	3.90	4.00	4.10
E2	0.075	0.079	0.083	1.90	2.00	2.10
e	0.020 BSC			0.50 BSC		
L	0.012	0.016	0.020	0.30	0.40	0.50
y	0.003			0.08		

**24. Top Marking Information**

**A71X05AQFI**

- Part No. : **71X05AQFI**
- Pin Count : **20**
- Package Type : **QFN**
- Dimension : **4\*4 mm**
- Mark Method : **Laser Mark**
- Character Type : **Arial**

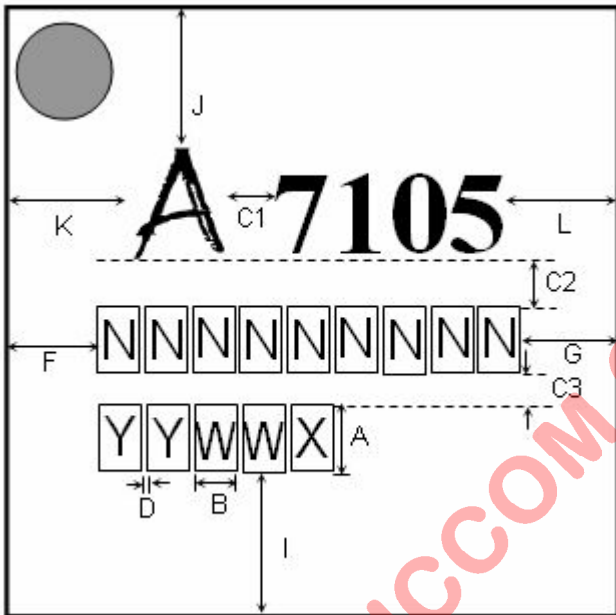

AMICCOM CONFIDENTIAL

**A : 0.55**  
**B : 0.36**  
**C1 : 0.25    C2 : 0.3    C3 : 0.2**  
**D : 0.03**  
**A1 : 0.75**  
**B2 : 0.7**

Y	Y	W	W	: DATECODE					
X				: PKG HOUSE ID					
N	N	N	N	N	N	N	N	N	: LOT NO. (max. 9 characters)

**F=G**  
**I=J**  
**K=L**

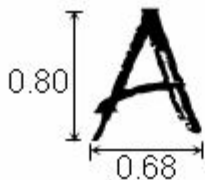

**25. Reflow Profile**

LEAD FREE (GREEN) PROFILE :

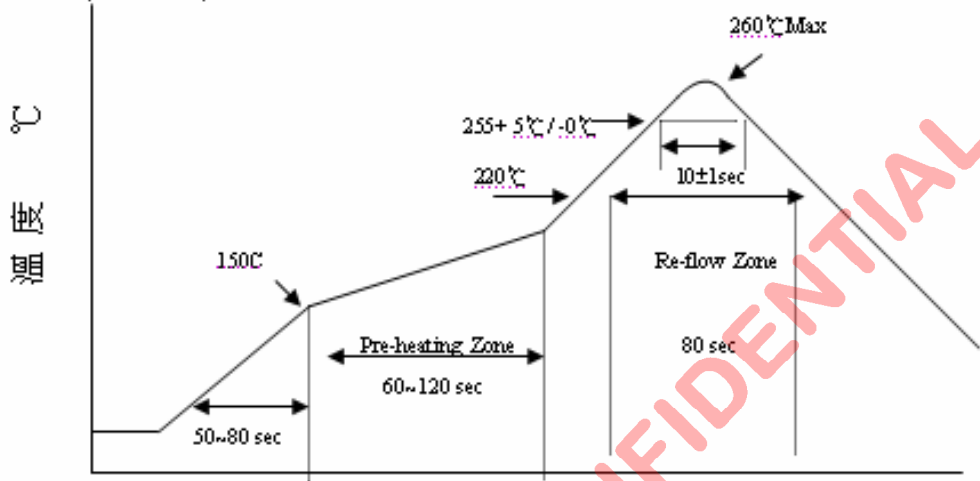

Actual Measurement Graph



**26. Type Reel Information**

**Cover / Carrier Tape Dimension**

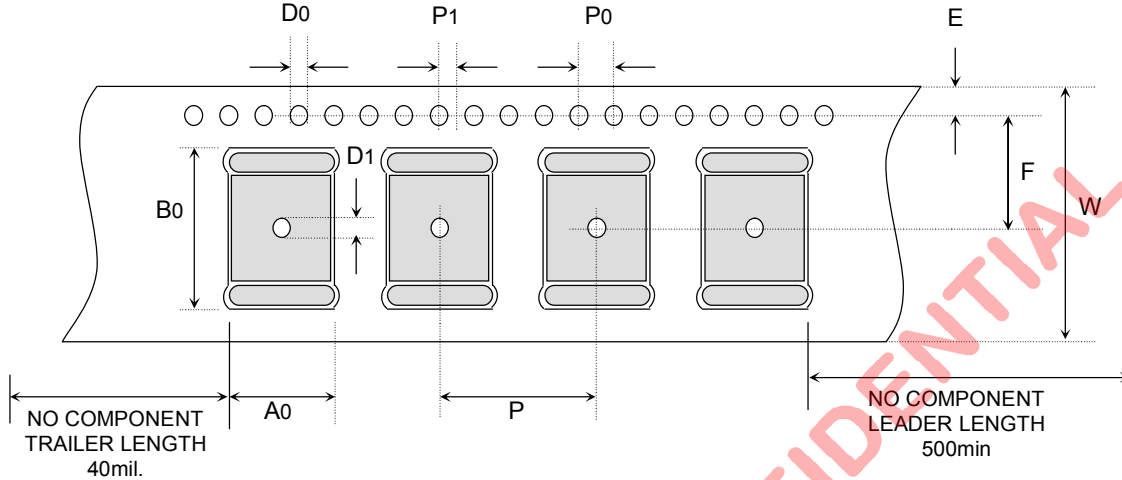

**11 EA IC**

**60cm±4cm**

TYPE	P	A0	B0	P0	P1	D0	D1	E	F	W
20 QFN 4*4	8	4.35	4.35	4.0	2.0	1.5	1.5	1.75	5.5	12
24 QFN 4*4	8	4.4	4.4	4.0	2.0	1.5	1.5	1.75	5.5	12
32 QFN 5*5	8	5.25	5.25	4.0	2.0	1.5	1.5	1.75	5.5	12
48 QFN 7*7	12	7.25	7.25	4.0	2.0	1.5	1.5	1.75	7.5	16
DFN-10	4	3.2	3.2	4.0	2.0	1.5	-	1.75	1.9	8
20 SSOP	12	8.2	7.5	4.0	2.0	1.5	1.5	1.75	7.5	16
24 SSOP	12	8.2	8.8	4.0	2.0	1.5	1.5	1.75	7.5	16
28 SSOP (150mil)	8	6	10	4.0	2.0	1.5	1.5	1.75	7.5	16

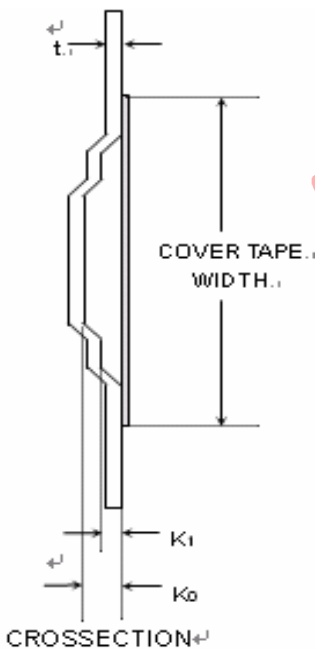

TYPE	K0	K1	t
20 QFN (4X4)	1.1	-	0.3
24 QFN (4X4)	1.4	-	0.3
32 QFN (5X5)	1.1	-	0.3
48 QFN (7X7)	1.1	-	0.3
DFN-10	0.75	-	0.25
20 SSOP	2.5	-	0.3
24 SSOP	2.1	-	0.3
28 SSOP (150mil)	2.5	-	0.3

COVER TAPE WIDTH
9.2
9.2
9.2
13.3
8
13.3
13.3
12.5

Unit : mm



**REEL DIMENSIONS**

UNIT IN mm

TYPE	G	N	T	M	D	K	L	R
20 QFN(4X4) 24 QFN(4X4) 32 QFN(5X5) DFN-10	12.8+0.6/-0.4	100 REF	18.2(MAX)	1.75±0.25	13.0+0.5/-0.2	2.0±0.5	330+ 0.00/-1.0	20.2
48 QFN(7X7)	16.8+0.6/-0.4	100 REF	22.2(MAX)	1.75±0.25	13.0+0.5/-0.2	2.0±0.5	330+ 0.00/-1.0	20.2
28 SSOP (150mil)	20.4+0.6/-0.4	100 REF	25(MAX)	1.75±0.25	13.0+0.5/-0.2	2.0±0.5	330+ 0.00/-1.0	20.2
20 SSOP 24 SSOP	16.4+2.0/-0.0	100 REF	22.4(MAX)	1.75±0.25	13.0+0.2/-0.2	1.9±0.4	330+ 0.00/-1.0	20.2

