



Valued Quality. Delivered.

TEST REPORT

Report No.: 17041140HKG-001

Spin Master Toys Far East Ltd.

Application
For
Certification
(Original Grant)
(FCC ID: PQN1442813M56)

Transmitter

Prepared and Checked by:

Approved by:

Signed On File
Leung Sung Tak, Andy
Engineer

Wong Kwok Yeung, Kenneth
Senior Lead Engineer
Date: April 24, 2017

- Intertek's standard Terms and Conditions can be obtained at our website <http://www.intertek.com/terms/>.
- The test report only allows to be revised within the retention period unless further standard or the requirement was noticed.
- This report is for the exclusive use of Intertek's Client and is provided pursuant to the agreement between Intertek and its Client. Intertek's responsibility and liability are limited to the terms and conditions of the agreement. Intertek assumes no liability to any party, other than to the Client in accordance with the agreement, for any loss, expense or damage occasioned by the use of this report. Only the Client is authorized to permit copying or distribution of this report and then only in its entirety. Any use of the Intertek name or one of its marks for the sale or advertisement of the tested material, product or service must first be approved in writing by Intertek. The observations and test results in this report are relevant only to the sample tested. This report by itself does not imply that the material, product, or service is or has ever been under an Intertek certification program.
- © 2016 Intertek

Intertek Testing Services Hong Kong Ltd.

2/F., Garment Centre, 576 Castle Peak Road, Kowloon, Hong Kong.

Tel: (852) 2173 8888 Fax: (852) 2785 5487 Website: www.hk.intertek-ettsemko.com

INTERTEK TESTING SERVICES

GENERAL INFORMATION

Grantee:	Spin Master Toys Far East Ltd.
Grantee Address:	Room 1113, 11/F, Chinachem Golden Plaza, 77 Mody Road, Tsim Sha Tsui East, Kowloon, Hong Kong.
Contact Person:	Andy Wong
Tel:	(852) 2301-3822
Fax:	N/A
e-mail:	andyw@spinmaster.com
Manufacturer:	Spin Master Toys Far East Ltd.
Manufacturer Address:	Room 1113, 11/F, Chinachem Golden Plaza, 77 Mody Road, Tsim Sha Tsui East, Kowloon, Hong Kong.
Brand Name:	Spin Master Ltd.
Mode:	14428
Phantom No.:	20086358
Type of EUT:	Transmitter
Description of EUT:	DOG Zoomer Pony
Serial Number:	N/A
FCC ID:	PQN1442813M56
Date of Sample Submitted:	April 21, 2017
Date of Test:	April 21, 2017 to April 21, 2017
Report No.:	17041140HKG-001
Report Date:	April 24, 2017
Environmental Conditions:	Temperature: +10 to 40°C Humidity: 10 to 90%

INTERTEK TESTING SERVICES

SUMMARY OF TEST RESULT

TEST SPECIFICATION	REFERENCE	RESULTS
Transmitter Field Strength Frequency Stability	15.225	Pass
Radiated Emission Radiated Emission on the Bandedge	15.209	Pass
Radiated Emission in Restricted Bands	15.205	Pass

The equipment under test is found to be complying with the following standards:
FCC Part 15, October 1, 2015 Edition

- Note: 1. The EUT uses a permanently attached antenna which, in accordance to section 15.203, is considered sufficient to comply with the provisions of this section.
2. Pursuant to FCC part 15 Section 15.215(c), the 20 dB bandwidth of the emission was contained within the frequency band designated (mentioned as above) which the EUT operated. The effects, if any, from frequency sweeping, frequency hopping, other modulation techniques and frequency stability over excepted variations in temperature and supply voltage were considered.

INTERTEK TESTING SERVICES

Table of Contents

1.0	<u>General Description</u>	1
1.1	Product Description	1
1.2	Related Submittal(s) Grants.....	1
1.3	Test Methodology	1
1.4	Test Facility	1
2.0	<u>System Test Configuration</u>	2
2.1	Justification.....	2
2.2	EUT Exercising Software.....	2
2.3	Special Accessories	2
2.4	Measurement Uncertainty.....	2
2.5	Support Equipment List and Description.....	2
3.0	<u>Emission Results</u>	3
3.1	Field Strength Calculation.....	3
3.2	Radiated Emission Configuration Photograph	4
3.3	Radiated Emission Data	4
3.4	Frequency Stability.....	7
4.0	<u>Equipment Photographs</u>	8
5.0	<u>Product Labelling</u>	8
6.0	<u>Technical Specifications</u>	8
7.0	<u>Instruction Manual</u>	8
8.0	<u>Miscellaneous Information</u>	9
8.1	Radiated Emission on the Bandedge.....	9
8.2	Discussion of Pulse Desensitization	10
8.3	Calculation of Average Factor.....	10
8.4	Emissions Test Procedures	11
9.0	<u>Confidentiality Request</u>	14
10.0	<u>Equipment List</u>	14

INTERTEK TESTING SERVICES

1.0 General Description

1.1 Product Description

The Equipment Under Test (EUT) is a 13.56MHz Transmitter (RFID). The EUT is powered by 4 x 1.5V AA batteries. After Placing the corresponding “Sugar Cube” on the EUT, Different mode will be applied to EUT such as dance, move quickly and get different sound effects.

Antenna Type: Internal, Integral

For electronic filing, the brief circuit description is saved with filename: descri.pdf.

1.2 Related Submittal(s) Grants

This is a single application for certification of a transmitter.

1.3 Test Methodology

Radiated emission measurements was performed according to the procedures in ANSI C63.10 (2013). All radiated measurements were performed in an 3m Chamber. Preliminary scans were performed in the 3m Chamber only to determine worst case modes. All radiated tests were performed at an antenna to EUT distance of 3 meters, unless stated otherwise in the “**Justification Section**” of this Application.

1.4 Test Facility

The 3m Chamber facility used to collect the radiated data is located at Workshop No. 3, G/F., World-Wide Industrial Centre, 43-47 Shan Mei Street, Fo Tan, Sha Tin, N.T., Hong Kong. This test facility and site measurement data have been placed on file with the FCC.

INTERTEK TESTING SERVICES

2.0 **System Test Configuration**

2.1 Justification

The system was configured for testing in a typical fashion (as a customer would normally use it), and in the confines as outlined in ANSI C63.10 (2013).

The device was powered by new 4X1.5V AA batteries.

For maximizing emissions below 30 MHz, the EUT was rotated through 360°, the centre of the loop antenna was placed 1 meter above the ground, and the antenna polarization was changed. For maximizing emission at and above 30 MHz, the EUT was rotated through 360°, the antenna height was varied from 1 meter to 4 meters above the ground plane, and the antenna polarization was changed. This step by step procedure for maximizing emissions led to the data report in Exhibit 3.0.

The unit was operated standalone and placed in the center of the turntable.

The equipment under test (EUT) was configured for testing in a typical fashion (as a customer would normally use it). The EUT was mounted to a plastic stand if necessary and placed on the wooden turntable, which enabled the engineer to maximize emissions through its placement in the three orthogonal axes.

2.2 EUT Exercising Software

There was no special software to exercise the device. Once the unit is powered up, it transmits the RF signal continuously.

2.3 Special Accessories

There are no special accessories necessary for compliance of this product.

2.4 Measurement Uncertainty

When determining of the test conclusion, the Measurement Uncertainty of test has been considered.

2.5 Support Equipment List and Description

N/A.

INTERTEK TESTING SERVICES

3.0 Emission Results

Data is included of the worst case configuration (the configuration which resulted in the highest emission levels). A sample calculation, configuration photographs and data tables of the emissions are included.

3.1 Field Strength Calculation

The field strength is calculated by adding the Antenna Factor and Cable Factor, and subtracting the Amplifier Gain (if any), Average Factor (optional) from the measured reading. The basic equation with a sample calculation is as follows:

$$FS = RA + AF + CF - AG - AV$$

where

- FS = Field Strength in dB μ V/m
- RA = Receiver Amplitude (including preamplifier) in dB μ V
- CF = Cable Attenuation Factor in dB
- AF = Antenna Factor in dB
- AG = Amplifier Gain in dB
- AV = Average Factor in dB

In the following table(s), the reading shown on the data table reflects the preamplifier gain. An example for the calculations in the following table is as follows:

$$FS = RR + LF$$

where

- FS = Field Strength in dB μ V/m
- RR = RA - AG - AV in dB μ V
- LF = CF + AF in dB

Assume a receiver reading of 52.0 dB μ V is obtained. The antenna factor of 7.4 dB and cable factor of 1.6 dB are added. The amplifier gain of 29 dB and average factor of 5 dB are subtracted, giving a field strength of 27 dB μ V/m. This value in dB μ V/m was converted to its corresponding level in μ V/m.

$$\begin{aligned} RA &= 52.0 \text{ dB}\mu\text{V/m} \\ AF &= 7.4 \text{ dB} & RR &= 18.0 \text{ dB}\mu\text{V} \\ CF &= 1.6 \text{ dB} & LF &= 9.0 \text{ dB} \\ AG &= 29.0 \text{ dB} \\ AV &= 5.0 \text{ dB} \\ FS &= RR + LF \\ FS &= 18 + 9 = 27 \text{ dB}\mu\text{V/m} \end{aligned}$$

Level in μ V/m = Common Antilogarithm [(27 dB μ V/m)/20] = 22.4 μ V/m

INTERTEK TESTING SERVICES

3.2 Radiated Emission Configuration Photograph

The worst case in radiated emission was found at 732.421 MHz

For electronic filing, the worst case radiated emission configuration photographs are saved with filename: radiated photos.pdf.

3.3 Radiated Emission Data

The data on the following page lists the significant emission frequencies, the limit and the margin of compliance. Numbers with a minus sign are below the limit.

Judgment: Passed by 4.6 dB

INTERTEK TESTING SERVICES

Company: Spin Master Toys Far East Ltd.
 Model: 14428
 Worst-Case Operating Mode: Transmitting

Date of Test: April 21, 2017

Table 1
Radiated Emissions
Pursuant to Section 15.225 Requirement

Polarization	Frequency (MHz)	Reading (dB μ V)	Pre-amp (dB)	Antenna Factor (dB)	Net at 3m (dB μ V/m)	Distance Factor (-dB)	Calculated at 30m (dB μ V/m)	Limit at 30m (dB μ V/m)	Margin (dB)
V	13.560	41.1	0	10.8	51.9	40.0	19.7	84.0	-64.3
V	27.120	36.1	0	10.8	36.1	40.0	-18.6	29.5	-48.1

Polarization	Frequency (MHz)	Reading (dB μ V)	Pre-Amp (dB)	Antenna Factor (dB)	Average Factor (dB)	Net at 3m (dB μ V/m)	Limit at 3m (dB μ V/m)	Margin (dB)
V	40.680	35.4	16	10.0	0.0	29.4	40.0	-10.6
V	54.240	34.6	16	11.0	-	29.6	40.0	-10.4
V	67.800	37.8	16	8.0	-	29.8	40.0	-10.2
V	81.360	40.1	16	7.0	-	31.1	40.0	-8.9
V	94.920	35.5	16	11.0	-	30.5	43.5	-13.0
V	108.480	32.9	16	14.0	-	30.9	43.5	-12.6
V	122.040	31.8	16	14.0	-	29.8	43.5	-13.7
V	135.600	33.2	16	14.0	-	31.2	43.5	-12.3
V	149.160	29.4	16	14.0	-	27.4	43.5	-16.1

- NOTES: 1. Peak Detector Data unless otherwise stated.
2. All measurements were made at 3 meters. Harmonic emissions not detected at the 3-meter distances were measured at 0.3-meter and an inverse proportional extrapolation was performed to compare the signal level to the 3-meter limit. No other harmonic emissions than those reported were detected at a test distance of 0.3-meter.
3. Negative sign in the column shows value below limit.
4. Loop antenna is used for the emissions below 30MHz.
5. Emission (the row indicated by **bold italic**) within the restricted band meets the requirement of FCC Part 15 Section 15.205.
6. Measurement Uncertainty is ± 5.3 dB at a level of confidence of 95%.

INTERTEK TESTING SERVICES

Company: Spin Master Toys Far East Ltd.
 Model: 14428
 Worst-Case Operating Mode: transmitting

Date of Test: April 21, 2017

Table 2
Radiated Emissions
Pursuant to Section 15.225 Requirement

Polarization	Frequency (MHz)	Reading (dB μ V)	Pre-Amp (dB)	Antenna Factor (dB)	Average Factor (dB)	Net at 3m (dB μ V/m)	Limit at 3m (dB μ V/m)	Margin (dB)
V	63.344	29.6	16	9.0	0.0	22.6	40.0	-17.4
V	140.580	31.1	16	14.0	-	29.1	43.5	-14.4
H	256.010	33.5	16	21.0	-	38.5	46.0	-7.5
V	691.783	24.3	16	30.0	-	38.3	46.0	-7.7
V	718.943	24.9	16	30.0	-	38.9	46.0	-7.1
V	732.421	27.4	16	30.0	-	41.4	46.0	-4.6
V	759.553	23.6	16	30.0	-	37.6	46.0	-8.4
V	786.721	23.8	16	31.0	-	38.8	46.0	-7.2

- NOTES: 1. Peak Detector Data unless otherwise stated.
2. All measurements were made at 3 meters. Harmonic emissions not detected at the 3-meter distances were measured at 0.3-meter and an inverse proportional extrapolation was performed to compare the signal level to the 3-meter limit. No other harmonic emissions than those reported were detected at a test distance of 0.3-meter.
3. Negative sign in the column shows value below limit.
4. Horn antenna is used for the emission over 1000MHz.
5. Emission (the row indicated by **bold italic**) within the restricted band meets the requirement of FCC Part 15 Section 15.205.
6. Measurement Uncertainty is ± 5.3 dB at a level of confidence of 95%.

INTERTEK TESTING SERVICES

3.4 Frequency Stability

FCC Part 15 Section 15.225

Data Table Frequency stability with respect to ambient temperature

Operating frequency		Model: 14428		
Test Voltage (V)	Temperature (°C)	Measured frequency (MHz)	Frequency error (%)	Limit (%)
6.0	+ 50	13.562292	+0.000280	±0.01
	+ 40	13.562290	+0.000265	±0.01
	+ 30	13.562282	+0.000206	±0.01
	+ 20	13.562254	0	±0.01
	+ 10	13.562282	+0.000206	±0.01
	0	13.562288	+0.000251	±0.01
	- 10	13.562307	+0.000391	±0.01
	- 20	13.562263	+0.000007	±0.01

Measurement Uncertainty is $\pm 1.141\text{Hz}$ (13.56MHz) at a level of confidence of 95%.

INTERTEK TESTING SERVICES

4.0 **Equipment Photographs**

For electronic filing, the photographs are saved with filename: external photos.pdf and internal photos.pdf.

5.0 **Product Labelling**

For electronics filing, the FCC ID label artwork and the label location are saved with filename: label.pdf.

6.0 **Technical Specifications**

For electronic filing, the block diagram and schematic of the tested EUT are saved with filename: block.pdf and circuit.pdf respectively.

7.0 **Instruction Manual**

For electronic filing, a preliminary copy of the Instruction Manual is saved with filename: manual.pdf.

This manual will be provided to the end-user with each unit sold/leased in the United States.

INTERTEK TESTING SERVICES

8.0 Miscellaneous Information

The miscellaneous information includes details of the test procedure.

8.1 Measured Bandwidth

The plot saved in be.pdf which shows the fundamental emission is confined in the specified band. The emission of the fundamental is 19.7 dB μ V/m and it is below the limit of 50.5 dB μ V/m in the range of (13.410 – 13.553 MHz) and (13.710 - 14.010 MHz) and the limit of 40.5 dB μ V/m in the frequency range of (13.110 – 14.410 MHz) and (13.710 – 14.010 MHz). In the frequency range from 13.110 – 14.010 MHz, we cannot find any emission higher than the fundamental emission. Therefore they meet the requirement of Section 15.225(a), (b), (c), & (d).

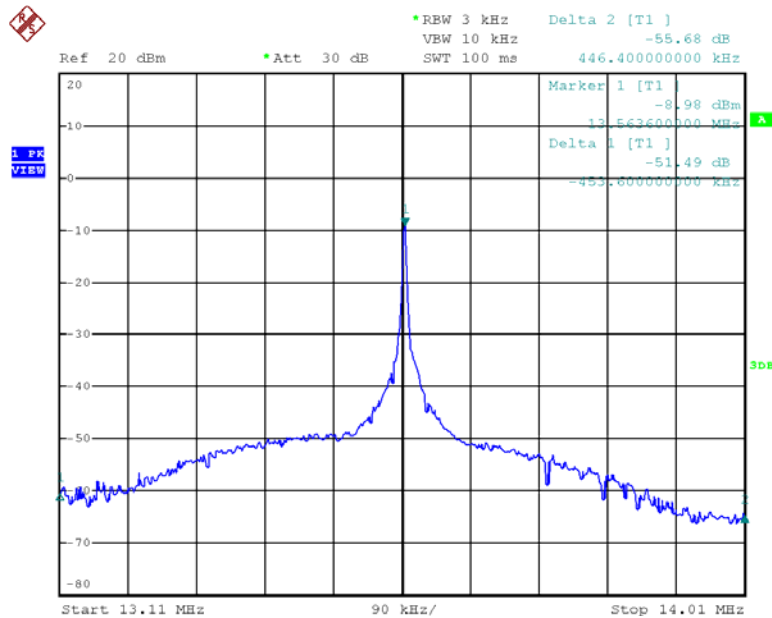

INTERTEK TESTING SERVICES

8.2 Discussion of Pulse Desensitization

Pulse desensitivity is not applicable for this device. Since the transmitter transmits the RF signal continuously.

8.3 Calculation of Average Factor

The average factor is not applicable for this device as the transmitted signal is a continuously signal.

INTERTEK TESTING SERVICES

8.4 Emissions Test Procedures

The following is a description of the test procedure used by Intertek Testing Services Hong Kong Ltd. in the measurements of transmitter operating under the Part 15, Subpart C rules.

The transmitting equipment under test (EUT) is placed on a wooden turntable which is four feet in diameter and approximately 0.8m in height above the ground plane for emission measurement at or below 1GHz and 1.5m in height above the ground plane for emission measurement above 1GHz. During the radiated emissions test, the turntable is rotated and any cables leaving the EUT are manipulated to find the configuration resulting in maximum emissions. The EUT is adjusted through all three orthogonal axis to obtain maximum emission levels. The antenna height and polarization are also varied during the testing to search for maximum signal levels. The height of the antenna is varied from one to four meters.

Detector function for radiated emissions is in peak mode. Average readings, when required, are taken by measuring the duty cycle of the equipment under test and subtracting the corresponding amount in dB from the measured peak readings. A detailed description for the calculation of the average factor can be found in Exhibit 8.3.

The frequency range scanned is from the lowest radio frequency signal generated in the device which is greater than 9 kHz to the tenth harmonic of the highest fundamental frequency or 40 GHz, whichever is lower.

INTERTEK TESTING SERVICES

8.4 Emissions Test Procedures (cont'd)

The EUT is warmed up for 15 minutes prior to the test.

AC power to the unit is varied from 85% to 115% nominal and variation in the fundamental emission field strength is recorded. If battery powered, a new, fully charged battery is used.

Conducted measurements were made as described in ANSI C63.10 (2013).

The IF bandwidth used for measurement of radiated signal strength was 100 kHz or greater when frequency is below 1000 MHz. Where pulsed transmissions of short enough pulse duration warrant, a greater bandwidth is selected according to the recommendations of Hewlett Packard Application Note 150-2. A discussion of whether pulse desensitivity is applicable to this unit is included in this report (See Exhibit 8.1). Above 1000 MHz, a resolution bandwidth of 1 MHz is used.

Transmitter measurements are normally conducted at a measurement distance of three meters. However, to assure low enough noise floor in the forbidden bands and above 1 GHz, signals are acquired at a distance of one meter or less. All measurements are extrapolated to three meters using inverse scaling, unless otherwise reported. Measurements taken at a closer distance are so marked.

INTERTEK TESTING SERVICES

8.4.1 Radiated Emission Test Setup

The figure below shows the test setup, which is utilized to make these measurements.

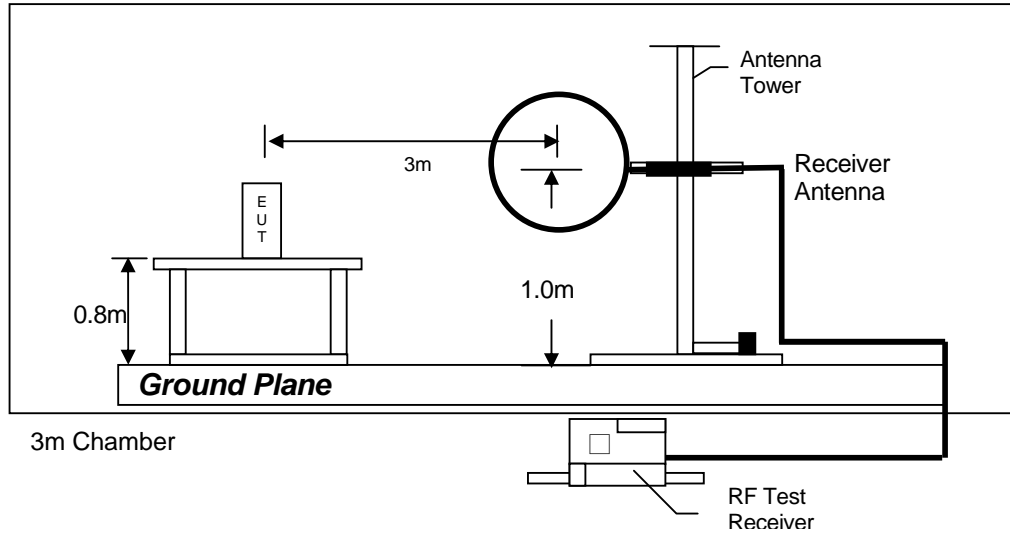

Test setup of radiated emissions up to 30MHz

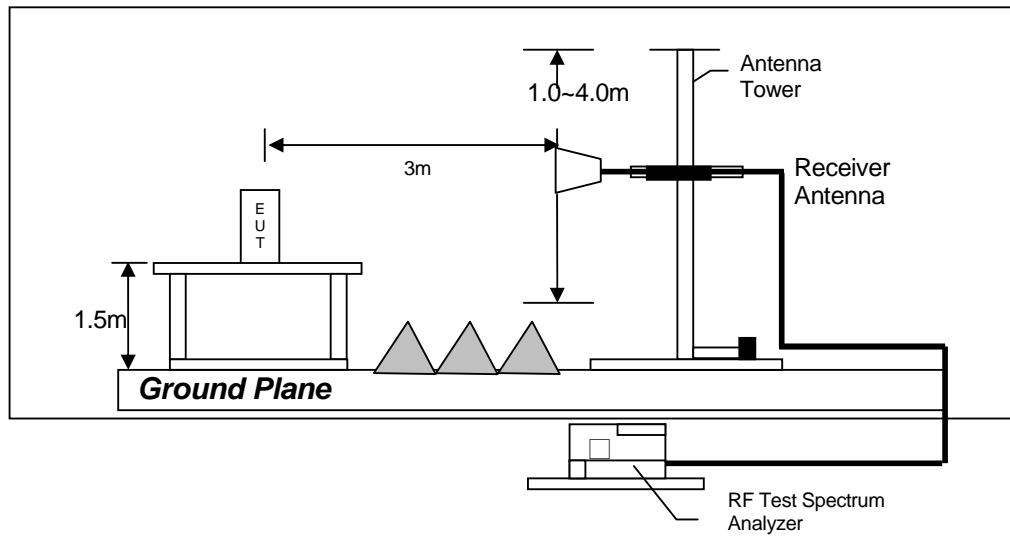

Test setup of radiated emissions above 1GHz

INTERTEK TESTING SERVICES

9.0 Confidentiality Request

For electronic filing, a preliminary copy of the confidentiality request is saved with filename: request.pdf.

10.0 Equipment List

1) Radiated Emissions Test

Equipment	EMI Test Receiver	Spectrum Analyzer	Biconical Antenna
Registration No.	EW-3156	EW-2253	EW-0571
Manufacturer	R&S	R&S	EMCO
Model No.	ESR26	FSP40	3104C
Calibration Date	Dec. 06, 2016	Jun. 15, 2016	May 18, 2016
Calibration Due Date	Dec. 06, 2017	Jun. 15, 2017	Nov. 18, 2017

Equipment	Active Loop H-field	Double Ridged Guide Antenna (1GHz - 18GHz)
Registration No.	EW-2313	EW-1133
Manufacturer	ELETROMETRIC	EMCO
Model No.	EM-6876	3115
Calibration Date	Jun. 27, 2016	Nov 5, 2015
Calibration Due Date	Dec. 27, 2017	May. 5, 2017

2) Bandedge Measurement

Equipment	Spectrum Analyzer
Registration No.	EW-3016
Manufacturer	R&S
Model No.	FSV40
Calibration Date	Jun.15, 2016
Calibration Due Date	Jun.15, 2017

3) Frequency Stability Measurement

Equipment	Spectrum Analyzer
Registration No.	EW-2249
Manufacturer	R&S
Model No.	FSP30
Calibration Date	Dec. 23, 2016
Calibration Due Date	Nov. 27, 2017

END OF TEST REPORT