



# M3814A

**SN: US00000000**



**UID: 00108351ABCD**



This device complies with part 15 of the FCC rules. Operation is subject to the following two conditions: (1) this device may not cause harmful interference and (2) this device must accept any interference received, including interference that may cause undesired operation. Except for batteries, no user serviceable parts inside. Made in USA of foreign and domestic components. Property of Philips Medical Systems, Andover, MA. Rx Only.

To return unit, please call toll free 866-246-7316

US



Certified



FCC ID:  
PQCM3814A

A-M3814-80002-1 Rev: A

PHILIPS MEDICAL SYSTEMS RESTRICTED

THIS DOCUMENT AND ANY ASSOCIATED DATA CONTAIN RESTRICTED INFORMATION THAT IS PHILIPS MEDICAL SYSTEMS PROPERTY. ONLY DISCLOSE OR DUPLICATE FOR OTHERS AS AUTHORIZED BY PHILIPS MEDICAL SYSTEMS.

ENGINEERING RESPONSIBILITY - 29C4

B-M3810-80008-1

REV	REF	REVISION DESCRIPTION	CHANGED BY	DATE
A	29C4-2002-10-00980	AS ISSUED	S J BLACKER	21-OCT-02

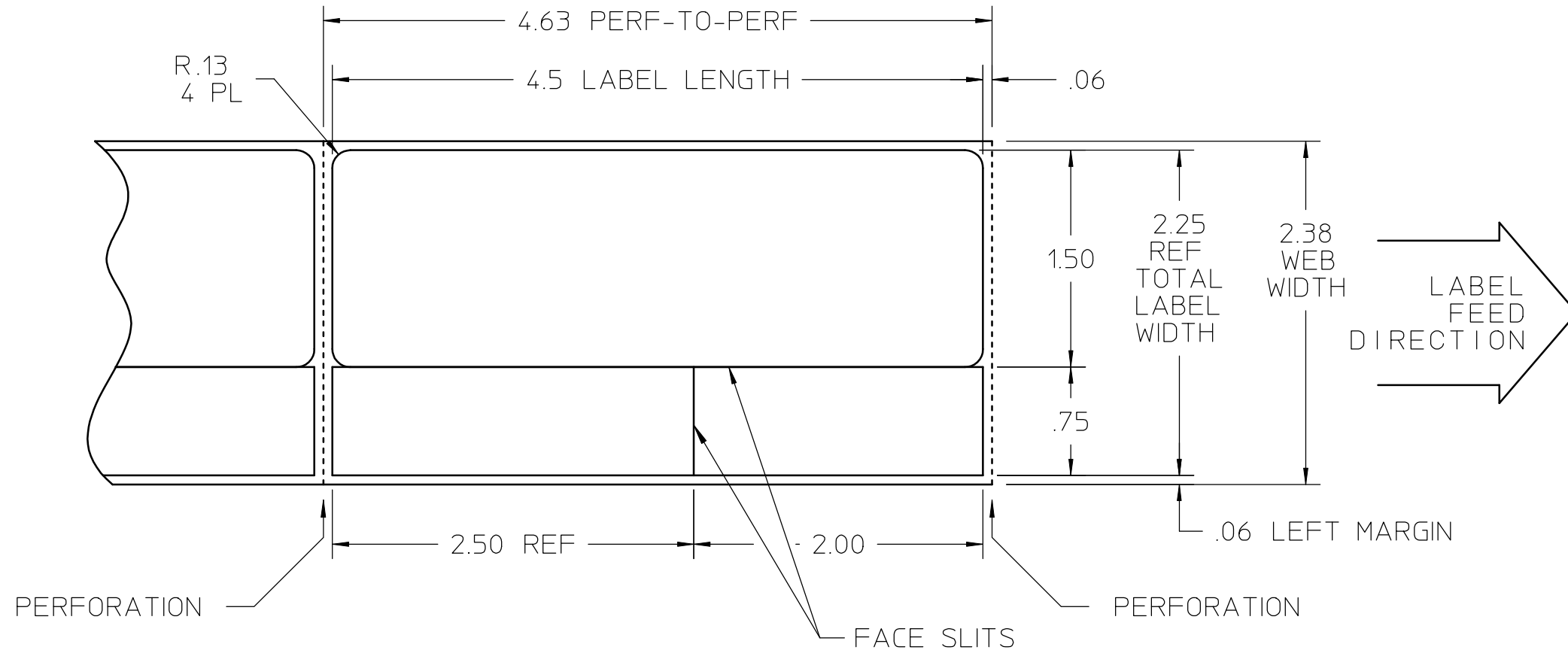

NOTES:

1. MATERIAL: CSA ACCEPTED ZEBRA Z-ULTIMATE 3000 WHITE, GLOSS POLYESTER WITH PERMANENT ACRYLIC ADHESIVE ON PERFORATED RELEASE LINER.
2. LABELS ROLLED ON 3 IN I.D. CORE SO THAT THE LABELS UNWIND FROM THE OUTSIDE
3. 1350 LABELS PER ROLL (ROLL O.D. 7.9 INCHES)
4. VENDOR: ZEBRA TECHNOLOGIES  
333 CORPORATE WOODS PARKWAY  
VERNON HILLS, ILLINOIS 60061  
TEL: 847-634-6700

UNLESS OTHERWISE SPECIFIED											
• DIMENSIONS ARE IN INCHES				ITEM	QTY	U/M	MATERIAL DESCRIPTION		MATL-PART NO		
• THIRD ANGLE PROJECTION											
• TOLERANCES				NAME		DATE		MODEL RATING & SN/UID LABEL STOCK			
X.X ± .020 ANGLES ± 1°				ACT Inc		07-JUN-02					
X.XX ± .010				DRAWN BY		GIL LEMKE					
X.XXX ± .005 ALL UNDIMENSIONED FEATURES PER NOTES				ENGINEER				PART NUMBER M3810-80008			
• ADHERENCE TO DWG A-5951-1561-1 (CORP STD SECTION 608) REQUIRED				DO NOT TAKE MEASUREMENTS FROM THIS PAPER PLOT						SCALE 1 : 1	B-M3810-80008-1
• ADHERENCE TO ASME SPEC. Y14.5M REVISION 1994 REQUIRED											

