



CETECOM ICT Services is now

CTC | advanced
member of RWTÜV group

TEST REPORT

Test report no.: 1-2846/16-02-04-B



Deutsche
Akkreditierungsstelle
D-PL-12076-01-01

Testing laboratory

CTC advanced GmbH

Untertuerkheimer Strasse 6 – 10

66117 Saarbruecken / Germany

Phone: + 49 681 5 98 - 0

Fax: + 49 681 5 98 - 9075

Internet: <http://www.ctcadvanced.com>

e-mail: mail@ctcadvanced.com

Accredited Testing Laboratory:

The testing laboratory (area of testing) is accredited according to DIN EN ISO/IEC 17025 (2005) by the Deutsche Akkreditierungsstelle GmbH (DAkkS)

The accreditation is valid for the scope of testing procedures as stated in the accreditation certificate with the registration number: D-PL-12076-01-01

Applicant

Philips Medizin Systeme Böblingen GmbH

Hewlett-Packard-Strasse 2

71034 Böblingen / GERMANY

Phone: +49 7031 463 1083

Fax: +49 7031 463 2944

Contact: Stephan Walter

e-mail: stephan.walter@philips.com

Phone: +49 7031 463 - 1083

Manufacturer

Philips Medizin Systeme Böblingen GmbH

Hewlett-Packard-Strasse 2

71034 Böblingen / GERMANY

Test standard/s

47 CFR Part 15

Title 47 of the Code of Federal Regulations; Chapter I; Part 15 - Radio frequency devices

RSS - 247 Issue 2

Digital Transmission Systems (DTSs), Frequency Hopping Systems (FHSs) and Licence-Exempt Local Area Network (LE-LAN) Devices

RSS - Gen Issue 4

Spectrum Management and Telecommunications Radio Standards Specifications - General Requirements and Information for the Certification of Radio Apparatus

For further applied test standards please refer to section 3 of this test report.

Test Item

Kind of test item: WLAN module IEEE 802.11 a / b / g / n

Model name: WLANBV3-A

FCC ID: PQC-WLANBV3

IC: 3549C-WLANBV3

Frequency: DTS band 2400 MHz to 2483.5 MHz

Technology tested: WLAN (DSSS/b-mode; OFDM/g-; n HT20/HT40-mode)

Antenna: Integrated antenna + 4 external antennas

Power supply: 5 V DC by USB interface

Temperature range: -10 °C to +70°C



This test report is electronically signed and valid without handwriting signature. For verification of the electronic signature, the public keys can be requested at the testing laboratory.

Test report authorized:

p.o.

Marco Bertolino
Lab Manager
Radio Communications & EMC

Test performed:

Andreas Luckenbill
Lab Manager
Radio Communications & EMC

1 Table of contents

1 Table of contents..... 2

2 General information 3

 2.1 Notes and disclaimer 3

 2.2 Application details 3

 2.3 Test laboratories sub-contracted 3

3 Test standard/s and references..... 4

4 Test environment 5

5 Test item 5

 5.1 General description 5

 5.2 Additional information 6

6 Description of the test setup 6

 6.1 Shielded semi anechoic chamber 7

 6.2 Shielded fully anechoic chamber 8

 6.3 Radiated measurements > 18 GHz 9

 6.4 Shielded fully anechoic chamber 10

 6.5 Conducted measurements with peak power meter & spectrum analyzer..... 11

7 Sequence of testing 12

 7.1 Sequence of testing radiated spurious 9 kHz to 30 MHz 12

 7.2 Sequence of testing radiated spurious 30 MHz to 1 GHz 13

 7.3 Sequence of testing radiated spurious 1 GHz to 18 GHz 14

 7.4 Sequence of testing radiated spurious above 18 GHz 15

8 Measurement uncertainty 16

9 Summary of measurement results 17

10 Additional comments..... 18

11 Measurement results 19

 11.1 Antenna gain..... 19

 11.2 Identify worst case data rate..... 23

 11.3 Maximum output power 24

 11.4 Duty cycle 25

 11.5 Peak power spectral density 26

 11.6 6 dB DTS bandwidth 35

 11.7 Occupied bandwidth – 99% emission bandwidth 44

 11.8 Occupied bandwidth – 20 dB bandwidth 53

 11.9 Band edge compliance conducted..... 62

 11.10 Spurious emissions conducted 67

 11.11 Spurious emissions radiated below 30 MHz 82

 11.12 Spurious emissions radiated 30 MHz to 1 GHz 89

 11.13 Spurious emissions radiated above 1 GHz 100

12 Observations 122

Annex A Document history 122

Annex B Further information 122

Annex C Accreditation Certificate 123

2 General information

2.1 Notes and disclaimer

The test results of this test report relate exclusively to the test item specified in this test report. CTC advanced GmbH does not assume responsibility for any conclusions and generalizations drawn from the test results with regard to other specimens or samples of the type of the equipment represented by the test item.

The test report may only be reproduced or published in full. Reproduction or publication of extracts from the report requires the prior written approval of CTC advanced GmbH.

The testing service provided by CTC advanced GmbH has been rendered under the current "General Terms and Conditions for CTC advanced GmbH".

CTC advanced GmbH will not be liable for any loss or damage resulting from false, inaccurate, inappropriate or incomplete product information provided by the customer.

Under no circumstances does the CTC advanced GmbH test report include any endorsement or warranty regarding the functionality, quality or performance of any other product or service provided.

Under no circumstances does the CTC advanced GmbH test report include or imply any product or service warranties from CTC advanced GmbH, including, without limitation, any implied warranties of merchantability, fitness for purpose, or non-infringement, all of which are expressly disclaimed by CTC advanced GmbH.

All rights and remedies regarding vendor's products and services for which CTC advanced GmbH has prepared this test report shall be provided by the party offering such products or services and not by CTC advanced GmbH. In no case this test report can be considered as a Letter of Approval.

This test report is electronically signed and valid without handwritten signature. For verification of the electronic signatures, the public keys can be requested at the testing laboratory.

This test report replaces the test report with the number 1-2846/16-02-04-A and dated 2017-04-04.

2.2 Application details

Date of receipt of order:	2016-11-17
Date of receipt of test item:	2017-01-17
Start of test:	2017-01-17
End of test:	2017-02-20
Person(s) present during the test:	-/-

2.3 Test laboratories sub-contracted

None

3 Test standard/s and references

Test standard	Date	Description
47 CFR Part 15	-/-	Title 47 of the Code of Federal Regulations; Chapter I; Part 15 - Radio frequency devices
RSS - 247 Issue 2	February 2017	Digital Transmission Systems (DTSs), Frequency Hopping Systems (FHSs) and Licence-Exempt Local Area Network (LE-LAN) Devices
RSS - Gen Issue 4	November 2014	Spectrum Management and Telecommunications Radio Standards Specifications - General Requirements and Information for the Certification of Radio Apparatus

Guidance	Version	Description
DTS: KDB 558074 D01	v03r05	Guidance for Performing Compliance Measurements on Digital Transmission Systems (DTS) Operating Under §15.247
ANSI C63.4-2014	-/-	American national standard for methods of measurement of radio-noise emissions from low-voltage electrical and electronic equipment in the range of 9 kHz to 40 GHz
ANSI C63.10-2013	-/-	American national standard of procedures for compliance testing of unlicensed wireless devices

4 Test environment

Temperature	:	T _{nom} T _{max} T _{min}	+22 °C during room temperature tests No tests under extreme conditions required. No tests under extreme conditions required.
Relative humidity content	:		35 %
Barometric pressure	:		1021 hpa
Power supply	:	V _{nom} V _{max} V _{min}	5 V DC by USB interface No tests under extreme conditions required. No tests under extreme conditions required.

5 Test item

5.1 General description

Kind of test item	:	WLAN module IEEE 802.11 a / b / g / n	
Type identification	:	WLANBV3-A	
HMN	:	-/-	
PMN	:	WLANBV3-A	
HVIN	:	WLANBV3-A	
FVIN	:	-/-	
S/N serial number	:	Radiated unit:	752C94
		Conducted unit:	752C94
HW hardware status	:	PW100120BA	
SW software status	:	3.2.0.137 api 3	
Frequency band	:	DTS band 2400 MHz to 2483.5 MHz (lowest channel 2412 MHz; highest channel 2462 MHz)	
Type of radio transmission	:	DSSS, OFDM	
Use of frequency spectrum	:		
Type of modulation	:	(D)BPSK, (D)QPSK, 16 – QAM, 64 – QAM	
Number of channels	:	11 (20 MHz) 9 (40 MHz)	
Antenna	:	Integrated antenna + 4 external antennas Integrated antenna: "IV2 TRNS Antenna WLAN IIT 1.4; 453564521811 Rev. 1631" External antennas: Ant M3002-66494 Ant 453564154611 Ant 453564175981 Ant 453564271931	
Power supply	:	5 V DC by USB interface	
Temperature range	:	-10°C to +70°C	

6.1 Shielded semi anechoic chamber

The radiated measurements are performed in vertical and horizontal plane in the frequency range from 9 kHz to 1 GHz in semi-anechoic chambers. The EUT is positioned on a non-conductive support with a height of 0.80 m above a conductive ground plane that covers the whole chamber. The receiving antennas are confirmed with specifications ANSI C63. These antennas can be moved over the height range between 1.0 m and 4.0 m in order to search for maximum field strength emitted from EUT. The measurement distances between EUT and receiving antennas are indicated in the test setups for the various frequency ranges. For each measurement, the EUT is rotated in all three axes until the maximum field strength is received. The wanted and unwanted emissions are received by spectrum analyzers where the detector modes and resolution bandwidths over various frequency ranges are set according to requirement ANSI C63.

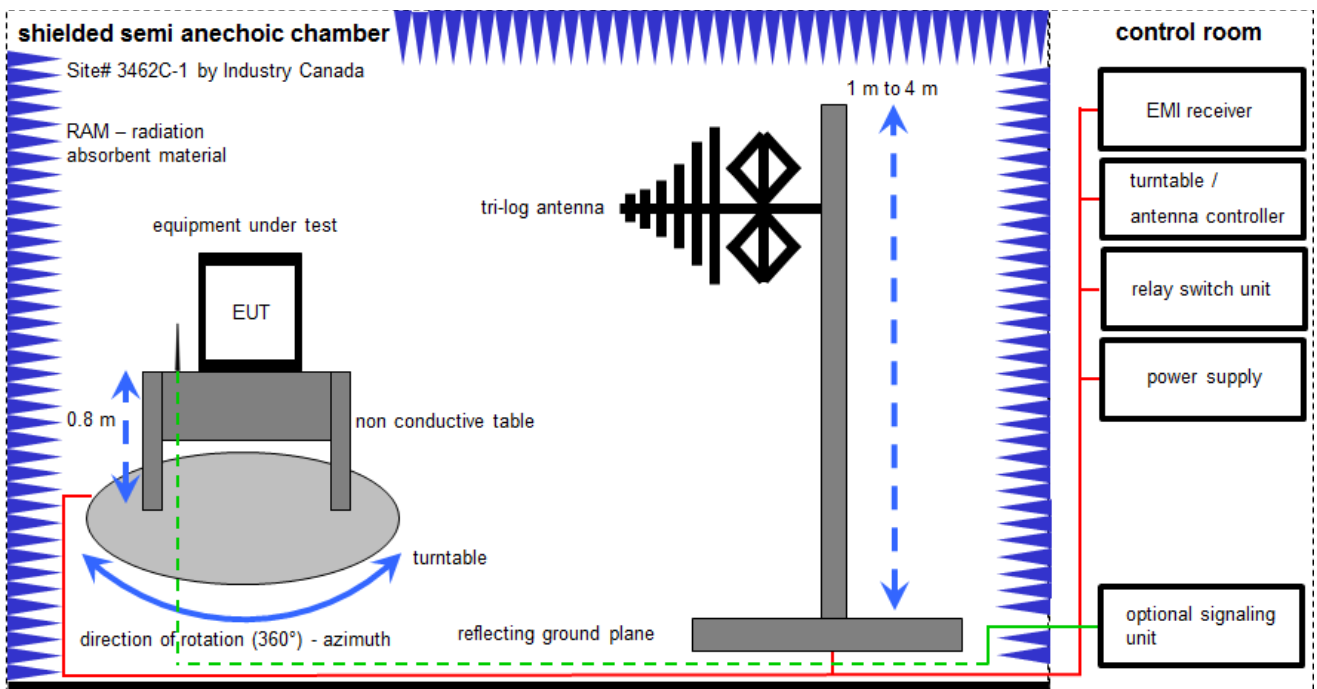

Measurement distance: tri-log antenna 10 meter

$$FS = UR + CL + AF$$

(FS-field strength; UR-voltage at the receiver; CL-loss of the cable; AF-antenna factor)

Example calculation:

$$FS [dB\mu V/m] = 12.35 [dB\mu V/m] + 1.90 [dB] + 16.80 [dB/m] = 31.05 [dB\mu V/m] (35.69 \mu V/m)$$

Equipment table:

No.	Lab / Item	Equipment	Type	Manufacturer	Serial No.	INV. No.	Kind of Calibration	Last Calibration	Next Calibration
1	A	Switch-Unit	3488A	HP	2719A14505	300000368	ev	-/-	-/-
2	A	EMI Test Receiver	ESCI 3	R&S	100083	300003312	k	08.03.2016	08.03.2017
3	A	Antenna Tower	Model 2175	ETS-Lindgren	64762	300003745	izw	-/-	-/-
4	A	Positioning Controller	Model 2090	ETS-Lindgren	64672	300003746	izw	-/-	-/-
5	A	Turntable Interface-Box	Model 105637	ETS-Lindgren	44583	300003747	izw	-/-	-/-
6	A	TRILOG Broadband Test-Antenna 30 MHz - 3 GHz	VULB9163	Schwarzbeck	295	300003787	k	25.04.2016	25.04.2018

6.2 Shielded fully anechoic chamber

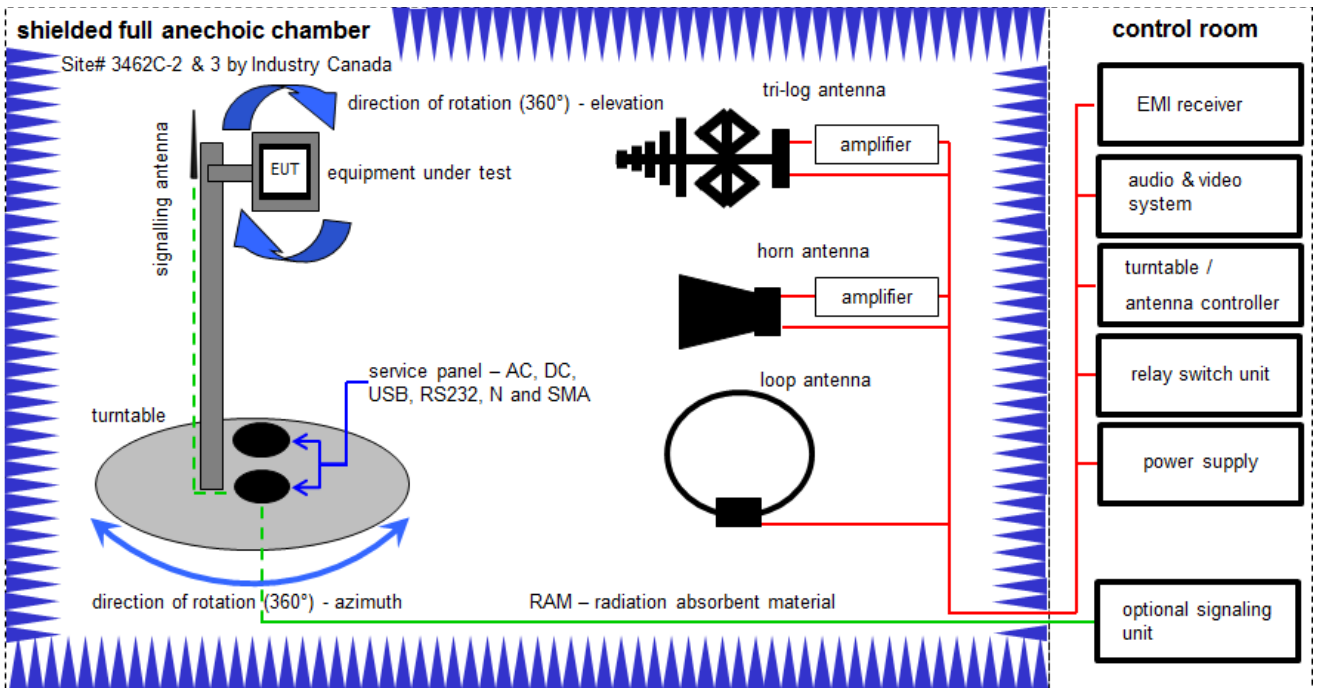

Measurement distance: tri-log antenna and horn antenna 3 meter & 1 meter; loop antenna 3 meter

$$FS = UR + CA + AF$$

(FS-field strength; UR-voltage at the receiver; CA-loss of the signal path; AF-antenna factor)

Example calculation:

$$FS \text{ [dB}\mu\text{V/m]} = 40.0 \text{ [dB}\mu\text{V/m]} + (-35.8) \text{ [dB]} + 32.9 \text{ [dB/m]} = 37.1 \text{ [dB}\mu\text{V/m]} \text{ (71.61 } \mu\text{V/m)}$$

Equipment table:

No.	Lab / Item	Equipment	Type	Manufacturer	Serial No.	INV. No.	Kind of Calibration	Last Calibration	Next Calibration
1	A	Active Loop Antenna 10 kHz to 30 MHz	6502	EMCO	2210	300001015	k	20.05.2015	20.05.2017
2	B	Double-Ridged Wavguide Horn Antenna 1-18.0GHz	3115	EMCO	9709-5290	300000212	k	13.08.2015	13.08.2017
3	A, B, C	EMI Test Receiver 20Hz- 26,5GHz	ESU26	R&S	100037	300003555	k	02.02.2016	02.02.2017
4	B	Highpass Filter	WHK1.1/15G-10SS	Wainwright	37	400000148	ne	-/-	-/-
5	B	Band Reject Filter	WRCG2400/2483-2375/2505-50/10SS	Wainwright	26	300003792	ne	-/-	-/-
6	B	Broadband Amplifier 0.5-18 GHz	CBLU5184540	CERNEX	22050	300004482	ev	-/-	-/-
7	B	Broadband Amplifier 5-13 GHz	CBLU5135235	CERNEX	22011	300004492	ev	-/-	-/-
8	A, B, C	4U RF Switch Platform	L4491A	Agilent Technologies	MY50000032	300004510	ne	-/-	-/-
9	A, B, C	Messrechner und Monitor	Intel Core i3 3220/3,3 GHz, Prozessor	Agilent Technologies	2V2403033A54 21	300004591	ne	-/-	-/-
10	A, B, C	NEXIO EMV-Software	BAT EMC	EMCO	2V2403033A54 21	300004682	ne	-/-	-/-
11	A, B, C	Vollabsorberkammer	BAT EMC	TDK	2V2403033A54 21	300003726	ne	-/-	-/-
12	C	TRILOG Broadband Test-Antenna 30 MHz - 3 GHz	VULB9163	Schwarzbeck	371	300003854	vIKI!	29.10.2014	29.10.2017

6.3 Radiated measurements > 18 GHz

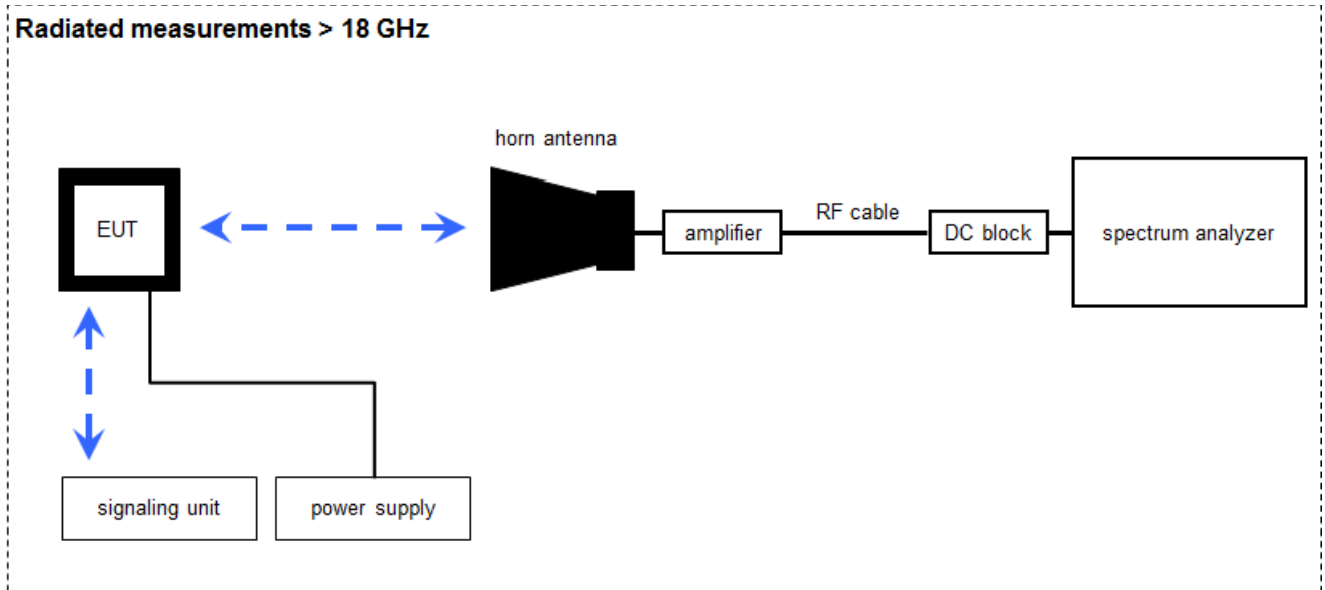

Measurement distance: horn antenna 50 cm

$$FS = U_R + CA + AF$$

(FS-field strength; U_R -voltage at the receiver; CA-loss signal path & distance correction; AF-antenna factor)

Example calculation:

$$FS \text{ [dB}\mu\text{V/m]} = 40.0 \text{ [dB}\mu\text{V/m]} + (-60.1) \text{ [dB]} + 36.74 \text{ [dB/m]} = 16.64 \text{ [dB}\mu\text{V/m]} \text{ (6.79 } \mu\text{V/m)}$$

Equipment table:

No.	Lab / Item	Equipment	Type	Manufacturer	Serial No.	INV. No.	Kind of Calibration	Last Calibration	Next Calibration
1	A	Amplifier 2-40 GHz	JS32-02004000-57-5P	MITEQ	1777200	300004541	ev	-/-	-/-
2	A	RF-Cable	ST18/SMAm/SMAm/48	Huber & Suhner	Batch no. 600918	400001182	ev	-/-	-/-
3	A	RF-Cable	ST18/SMAm/SMm/48	Huber & Suhner	Batch no. 127377	400001183	ev	-/-	-/-
4	A	DC-Blocker 0.1-40 GHz	8141A	Inmet	Batch no. 127377	400001185	ev	-/-	-/-
5	A	Std. Gain Horn Antenna 18.0 to 26.5 GHz	638	Narda	8402	300000486	k	10.09.2015	10.09.2017
6	A	Signal Analyzer 40 GHz	FSV40	R&S	101042	300004517	k	21.01.2016	21.01.2017

6.4 Shielded fully anechoic chamber

OTA – over the air performance

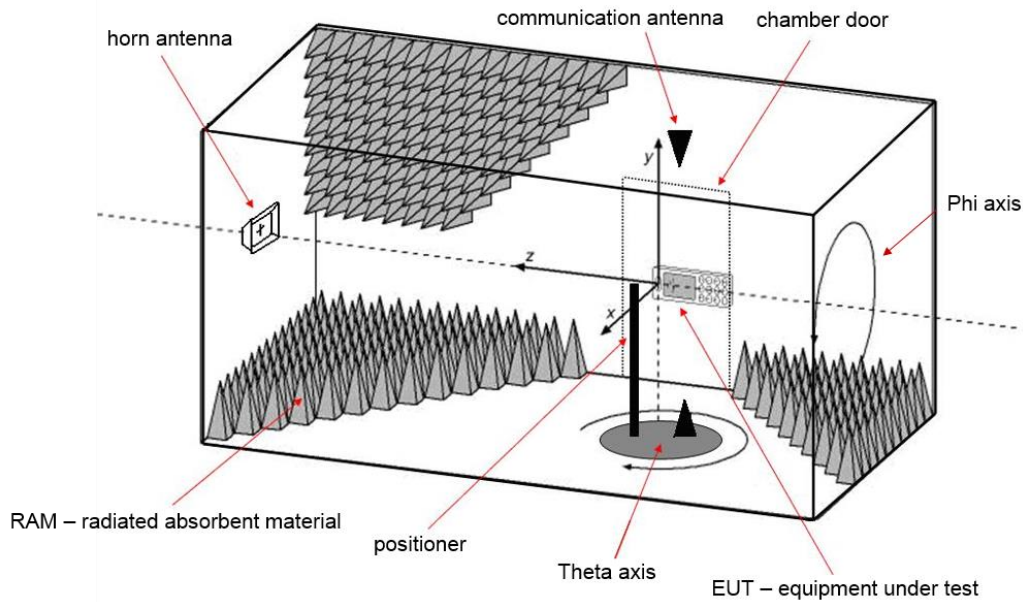

Equipment table:

No.	Lab / Item	Equipment	Type	Manufacturer	Serial No.	INV. No.	Kind of Calibration	Last Calibration	Next Calibration
1	A	Splitter	15542	Mini Circuits	15542	400000086	ev	-/-	-/-
2	A	Splitter	42000	Anaren	4730	400000085	ev	-/-	-/-
3	A	Switch Unit	TS-RSP	R&S	100155	300003281	ev	-/-	-/-
4	A	CTIA-Chamber	CTIA-Chamber AMS 8500	ETS-Lindgren Finland	-/-	300003327	ne	-/-	-/-
5	A	CTIA-Chamber - Positioning Equipment	CTIA-Chamber - Positioning Equipment	EMCO/2	-/-	300003328	ne	-/-	-/-
6	A	Limiting Amplifier	JLA 02-801	JCA Tech.	101	300003341	ne	-/-	-/-
7	A	Spectrum Analyzer	FSP30	R&S	100623	300003464	Ve	29.01.2017	30.01.2018

6.5 Conducted measurements with peak power meter & spectrum analyzer

Conducted measurements normal conditions

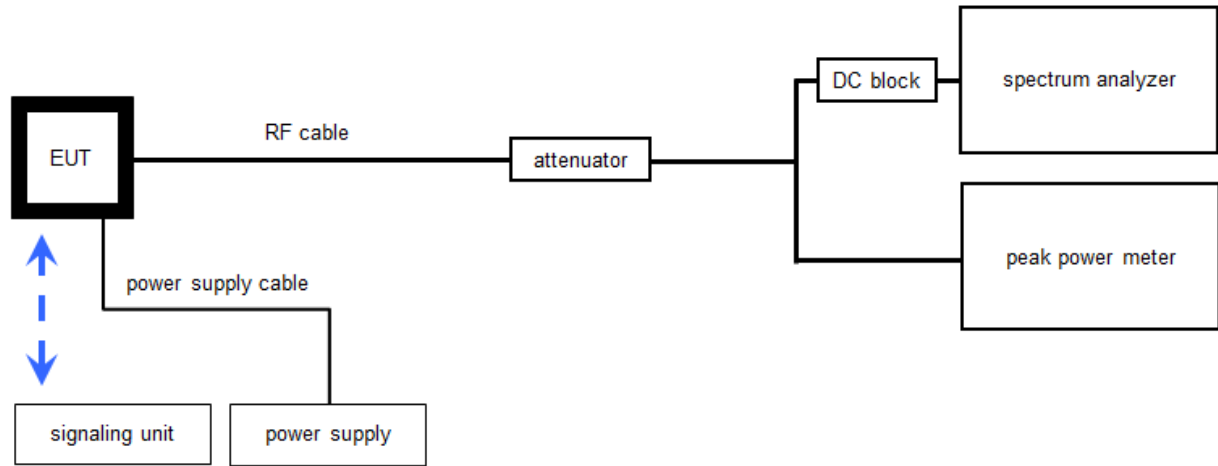

OP = AV + CA
 (OP-output power; AV-analyzer value; CA-loss signal path)

Example calculation:

OP [dBm] = 6.0 [dBm] + 11.7 [dB] = 17.7 [dBm] (58.88 mW)

Equipment table:

No.	Lab / Item	Equipment	Type	Manufacturer	Serial No.	INV. No.	Kind of Calibration	Last Calibration	Next Calibration
1	A, B	Switch / Control Unit	3488A	HP	2719A15013	300000151	ne	-/-	-/-
2	A, B	Hygro-Thermometer	-/, 5-45C, 20-100rF	HP	-/-	400000108	ev	07.09.2015	07.09.2017
3	A, B	Power Supply 0-20V, 0-5A	6632B	Agilent Technologies	GB42110541	400000562	vIKI!	26.01.2016	26.01.2019
4	A, B	PC-WLAN Tester	Intel Core i3 3220/3,3 GHz, Prozessor	Agilent Technologies	2V2403033A45 23	300004589	ne	-/-	-/-
5	A, B	Teststand	Teststand Custom Sequence Editor	National Instruments GmbH	2V2403033A45 23	300004590	ne	-/-	-/-
6	B	Power Sensor	NRP-Z81	R&S	100010	300003780	k	25.01.2016	25.01.2017
7	A, B	RF-Cable	ST18/SMAM/SMAM/60	Huber & Suhner	Batch no. 606844	400001181	ev	-/-	-/-
8	A	Coax Attenuator 10 dB 2W 0-40 GHz	MCL BW-K10-2W44+	Mini Circuits	Batch no. 606844	400001186	ev	-/-	-/-
9	A	Signal Analyzer 40 GHz	FSV40	R&S	101042	300004517	k	21.01.2016	21.01.2017

7 Sequence of testing

7.1 Sequence of testing radiated spurious 9 kHz to 30 MHz

Setup

- The equipment is set up to simulate normal operation mode as described in the user manual or defined by the manufacturer.
- If the EUT is a tabletop system, a 2-axis positioner with 1.5 m height is used.
- If the EUT is a floor standing device, it is placed directly on the turn table.
- Auxiliary equipment and cables are positioned to simulate normal operation conditions as described in ANSI C 63.4.
- The AC power port of the EUT (if available) is connected to a power outlet below the turntable.
- Measurement distance is 3 m (see ANSI C 63.4) – see test details.
- EUT is set into operation.

Premeasurement

- The turntable rotates from 0° to 315° using 45° steps.
- The antenna height is 1.5 m.
- At each turntable position the analyzer sweeps with positive-peak detector to find the maximum of all emissions.

Final measurement

- Identified emissions during the premeasurement are maximized by the software by rotating the turntable from 0° to 360°. In case of the 2-axis positioner is used the elevation axis is also rotated from 0° to 360°.
- The final measurement is done in the position (turntable and elevation) causing the highest emissions with quasi-peak (as described in ANSI C 63.4).
- Final levels, frequency, measuring time, bandwidth, turntable position, correction factor, margin to the limit and limit will be recorded. A plot with the graph of the premeasurement and the limit is stored.

7.2 Sequence of testing radiated spurious 30 MHz to 1 GHz

Setup

- The equipment is set up to simulate normal operation mode as described in the user manual or defined by the manufacturer.
- If the EUT is a tabletop system, a table with 0.8 m height is used, which is placed on the ground plane.
- If the EUT is a floor standing device, it is placed on the ground plane with insulation between both.
- Auxiliary equipment and cables are positioned to simulate normal operation conditions as described in ANSI C 63.4.
- The AC power port of the EUT (if available) is connected to a power outlet below the turntable.
- Measurement distance is 10 m or 3 m (see ANSI C 63.4) – see test details.
- EUT is set into operation.

Premeasurement

- The turntable rotates from 0° to 315° using 45° steps.
- The antenna is polarized vertical and horizontal.
- The antenna height changes from 1 m to 3 m.
- At each turntable position, antenna polarization and height the analyzer sweeps three times in peak to find the maximum of all emissions.

Final measurement

- The final measurement is performed for at least six highest peaks according to the requirements of the ANSI C63.4.
- Based on antenna and turntable positions at which the peak values are measured the software maximize the peaks by changing turntable position $\pm 45^\circ$ and antenna height between 1 and 4 m.
- The final measurement is done with quasi-peak detector (as described in ANSI C 63.4).
- Final levels, frequency, measuring time, bandwidth, antenna height, antenna polarization, turntable angle, correction factor, margin to the limit and limit are recorded. A plot with the graph of the premeasurement with marked maximum final results and the limit is stored.

7.3 Sequence of testing radiated spurious 1 GHz to 18 GHz

Setup

- The equipment is set up to simulate normal operation mode as described in the user manual or defined by the manufacturer.
- If the EUT is a tabletop system, a 2-axis positioner with 1.5 m height is used.
- If the EUT is a floor standing device, it is placed directly on the turn table.
- Auxiliary equipment and cables are positioned to simulate normal operation conditions as described in ANSI C 63.4.
- The AC power port of the EUT (if available) is connected to a power outlet below the turntable.
- Measurement distance is 3 m (see ANSI C 63.4) – see test details.
- EUT is set into operation.

Premeasurement

- The turntable rotates from 0° to 315° using 45° steps.
- The antenna is polarized vertical and horizontal.
- The antenna height is 1.5 m.
- At each turntable position and antenna polarization the analyzer sweeps with positive peak detector to find the maximum of all emissions.

Final measurement

- The final measurement is performed for at least six highest peaks according to the requirements of the ANSI C63.4.
- Based on antenna and turntable positions at which the peak values are measured the software maximizes the peaks by rotating the turntable from 0° to 360°. This measurement is repeated for different EUT-table positions (0° to 150° in 30°-steps) and for both antenna polarizations.
- The final measurement is done in the position (turntable, EUT-table and antenna polarization) causing the highest emissions with Peak and RMS detector (as described in ANSI C 63.4).
- Final levels, frequency, measuring time, bandwidth, turntable position, EUT-table position, antenna polarization, correction factor, margin to the limit and limit are recorded. A plot with the graph of the premeasurement with marked maximum final results and the limit is stored.

7.4 Sequence of testing radiated spurious above 18 GHz

Setup

- The equipment is set up to simulate normal operation mode as described in the user manual or defined by the manufacturer.
- Auxiliary equipment and cables are positioned to simulate normal operation conditions as described in ANSI C 63.4.
- The AC power port of the EUT (if available) is connected to a power outlet.
- The measurement distance is as appropriate (e.g. 0.5 m).
- The EUT is set into operation.

Premeasurement

- The test antenna is handheld and moved carefully over the EUT to cover the EUT's whole sphere and different polarizations of the antenna.

Final measurement

- The final measurement is performed at the position and antenna orientation causing the highest emissions with Peak and RMS detector (as described in ANSI C 63.4).
- Final levels, frequency, measuring time, bandwidth, correction factor, margin to the limit and limit are recorded. A plot with the graph of the premeasurement and the limit is stored.

8 Measurement uncertainty

Measurement uncertainty	
Test case	Uncertainty
Antenna gain	± 3 dB
Power spectral density	± 1.5 dB
DTS bandwidth	± 100 kHz (depends on the used RBW)
Occupied bandwidth	± 100 kHz (depends on the used RBW)
Maximum output power	± 1.5 dB
Detailed spurious emissions @ the band edge - conducted	± 1.5 dB
Band edge compliance radiated	± 3 dB
Spurious emissions conducted	± 3 dB
Spurious emissions radiated below 30 MHz	± 3 dB
Spurious emissions radiated 30 MHz to 1 GHz	± 3 dB
Spurious emissions radiated 1 GHz to 12.75 GHz	± 3.7 dB
Spurious emissions radiated above 12.75 GHz	± 4.5 dB
Spurious emissions conducted below 30 MHz (AC conducted)	± 2.6 dB

9 Summary of measurement results

<input checked="" type="checkbox"/>	No deviations from the technical specifications were ascertained
<input type="checkbox"/>	There were deviations from the technical specifications ascertained
<input type="checkbox"/>	This test report is only a partial test report. The content and verdict of the performed test cases are listed below.

TC Identifier	Description	Verdict	Date	Remark
RF-Testing	CFR Part 15 RSS - 247, Issue 2	See table!	2017-04-18	-/-

Test specification clause	Test case	Guideline	Temperature conditions	Power source voltages	Mode	C	NC	NA	NP	Remark
§15.247(b)(4) RSS - 247 / 5.4 (d)	Antenna gain	-/-	Nominal	Nominal	DSSS		-/-			-/-
RSS - 247 / 6.0	Duty cycle	-/-	Nominal	Nominal	DSSS OFDM		-/-			-/-
§15.247(e) RSS - 247 / 5.2 (b)	Power spectral density	KDB 558074 DTS clause: 10.2	Nominal	Nominal	DSSS OFDM	<input checked="" type="checkbox"/>	<input type="checkbox"/>	<input type="checkbox"/>	<input type="checkbox"/>	-/-
§15.247(a)(2) RSS - 247 / 5.2 (a)	DTS bandwidth	KDB 558074 DTS clause: 8.1	Nominal	Nominal	DSSS OFDM	<input checked="" type="checkbox"/>	<input type="checkbox"/>	<input type="checkbox"/>	<input type="checkbox"/>	-/-
RSS Gen clause 4.6.1	Occupied bandwidth	-/-	Nominal	Nominal	DSSS OFDM	<input checked="" type="checkbox"/>	<input type="checkbox"/>	<input type="checkbox"/>	<input type="checkbox"/>	-/-
§15.247(b)(3) RSS - 247 / 5.4 (d)	Maximum output power	KDB 558074 DTS clause: 9.1.2	Nominal	Nominal	DSSS OFDM	<input checked="" type="checkbox"/>	<input type="checkbox"/>	<input type="checkbox"/>	<input type="checkbox"/>	-/-
§15.247(d) RSS - 247 / 5.5	Detailed spurious emissions @ the band edge - conducted	-/-	Nominal	Nominal	DSSS OFDM	<input checked="" type="checkbox"/>	<input type="checkbox"/>	<input type="checkbox"/>	<input type="checkbox"/>	-/-
§15.205 RSS - 247 / 5.5 RSS - Gen	Band edge compliance conducted or radiated	KDB 558074 DTS clause: 13.3.2 and clause 12.2.2	Nominal	Nominal	DSSS OFDM	<input checked="" type="checkbox"/>	<input type="checkbox"/>	<input type="checkbox"/>	<input type="checkbox"/>	-/-
§15.247(d) RSS - 247 / 5.5	TX spurious emissions conducted	KDB 558074 DTS clause: 11.1 & 11.2 11.3	Nominal	Nominal	DSSS OFDM	<input checked="" type="checkbox"/>	<input type="checkbox"/>	<input type="checkbox"/>	<input type="checkbox"/>	-/-
§15.209(a) RSS-Gen	TX spurious emissions radiated below 30 MHz	-/-	Nominal	Nominal	DSSS OFDM	<input checked="" type="checkbox"/>	<input type="checkbox"/>	<input type="checkbox"/>	<input type="checkbox"/>	-/-
§15.247(d) RSS - 247 / 5.5 RSS-Gen	TX spurious emissions radiated 30 MHz to 1 GHz	-/-	Nominal	Nominal	DSSS OFDM	<input checked="" type="checkbox"/>	<input type="checkbox"/>	<input type="checkbox"/>	<input type="checkbox"/>	-/-
§15.247(d) RSS - 247 / 5.5 RSS-Gen	TX spurious emissions radiated above 1 GHz	-/-	Nominal	Nominal	DSSS OFDM	<input checked="" type="checkbox"/>	<input type="checkbox"/>	<input type="checkbox"/>	<input type="checkbox"/>	-/-
§15.109 RSS-Gen	RX spurious emissions radiated 30 MHz to 1 GHz	-/-	Nominal	Nominal	RX / idle	<input checked="" type="checkbox"/>	<input type="checkbox"/>	<input type="checkbox"/>	<input type="checkbox"/>	-/-
§15.109 RSS-Gen	RX spurious emissions radiated above 1 GHz	-/-	Nominal	Nominal	RX / idle	<input checked="" type="checkbox"/>	<input type="checkbox"/>	<input type="checkbox"/>	<input type="checkbox"/>	-/-
§15.107(a) §15.207	Conducted emissions < 30 MHz	-/-	Nominal	Nominal	DSSS OFDM	<input type="checkbox"/>	<input type="checkbox"/>	<input checked="" type="checkbox"/>	<input type="checkbox"/>	DC powered by USB

Note: C = Compliant; NC = Not compliant; NA = Not applicable; NP = Not performed

10 Additional comments

Reference documents: PowerTableWLANBV2-A

	Frequency [MHz]	2412	2417	2422	2427-2447	2452-2457	2462	2467-2472	2484
Data rate	--txrate								
802.11b 1Mbit/s	0	13	13	13	13	13	13	13	13
802.11b 2Mbit/s	1	13	13	13	13	13	13	13	13
802.11b 5.5Mbit/s	2	13	13	13	13	13	13	13	13
802.11b 11Mbit/s	3	13	13	13	13	13	13	13	13
802.11a/g 6 - 24Mbit/s	4-8	8	13	13	13	13	8,5	8,5	-
802.11a/g 36Mbit/s	9	8	13	13	13	13	8,5	8,5	-
802.11a/g 48Mbit/s	10	8	12,50	12,50	12,50	12,50	8,5	8,5	-
802.11a/g 54Mbit/s	11	8	11	11	11	11	8,5	8,5	-
802.11n MCS0 HT20	12	7	12,5	12,5	12,5	12,5	7,5	7,5	-
802.11n MCS1 HT20	13	7	12,5	12,5	12,5	12,5	7,5	7,5	-
802.11n MCS2 HT20	14	7	12,5	12,5	12,5	12,5	7,5	7,5	-
802.11n MCS3 HT20	15	7	12	12	12	12	7,5	7,5	-
802.11n MCS4 HT20	16	7	12	12	12	12	7,5	7,5	-
802.11n MCS5 HT20	17	7	12	12	12	12	7,5	7,5	-
802.11n MCS6 HT20	18	7	10,5	10,5	10,5	10,5	7,5	7,5	-
802.11n MCS7 HT20	19	5	5	5	5	5	5	5	-
802.11n MCS0 HT40	20	-	-	7	12,5	7,5	7,5	-	-
802.11n MCS1 HT40	21	-	-	7	12,5	7,5	7,5	-	-
802.11n MCS2 HT40	22	-	-	7	12,5	7,5	7,5	-	-
802.11n MCS3 HT40	23	-	-	7	12	7,5	7,5	-	-
802.11n MCS4 HT40	24	-	-	7	12	7,5	7,5	-	-
802.11n MCS5 HT40	25	-	-	7	12	7,5	7,5	-	-
802.11n MCS6 HT40	26	-	-	7	8	7,5	7,5	-	-
802.11n MCS7 HT40	27	-	-	5	5	5	5	-	-

Special test descriptions: None

Configuration descriptions: None

- Test mode:
- No test mode available.
Iperf was used to ping another device with the largest support packet size
 - Special software is used.
EUT is transmitting pseudo random data by itself

- Antennas and transmit operating modes:
- Operating mode 1 (single antenna)
 - Equipment with 1 antenna,
 - Equipment with 2 diversity antennas operating in switched diversity mode by which at any moment in time only 1 antenna is used,
 - Smart antenna system with 2 or more transmit/receive chains, but operating in a mode where only 1 transmit/receive chain is used)
 - Operating mode 2 (multiple antennas, no beamforming)
 - Equipment operating in this mode contains a smart antenna system using two or more transmit/receive chains simultaneously but without beamforming.
 - Operating mode 3 (multiple antennas, with beamforming)
 - Equipment operating in this mode contains a smart antenna system using two or more transmit/receive chains simultaneously with beamforming.
In addition to the antenna assembly gain (G), the beamforming gain (Y) may have to be taken into account when performing the measurements.

11 Measurement results

11.1 Antenna gain

Description:

The antenna gain of the complete system was determined Over-The-Air in a fully shielded anechoic chamber. The system's antenna was disconnected from the RF output of the EUT. An external 50 Ohms signal generator was used to feed the system's antenna with a constant signal at the certain frequency and a power level of 0dBm. The EUT was then rotated horizontally and vertically in steps of 15°. The emission at each position was measured with a horizontal and vertical polarized horn antenna. The resulting 3 dimensional antenna diagram displays the radiation character of the system at the tested frequency. The detected peak power (EIRP) equals the antenna gain.

Measurement parameters:

Measurement parameter	
Detector:	Peak
Sweep time:	Auto
Resolution bandwidth:	3 MHz
Video bandwidth:	3 MHz
Trace mode:	Max hold
Test setup:	See sub clause 6.4 A
Measurement uncertainty:	See sub clause 8

Limits:

FCC	IC
6 dBi / > 6 dBi output power and power density reduction required	

Results:

T _{nom}	V _{nom}	lowest channel 2412 MHz	middle channel 2437 MHz	highest channel 2462 MHz
Gain [dBi]		1.15	1.19	2.41

Plots:

Plot 1: Lowest channel, antenna diagram

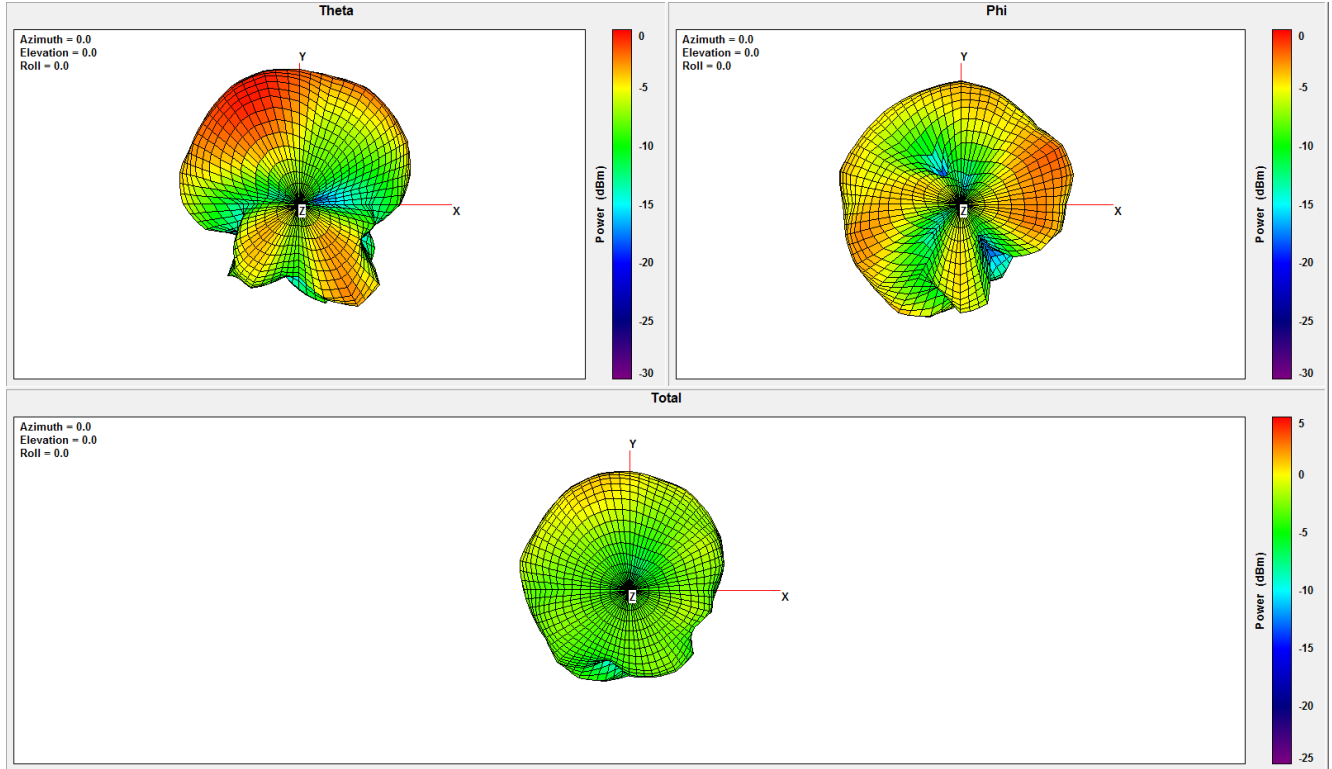

Plot 2: Lowest channel – Table of Results

Total	Point Values	
	Ant. Port Input Pwr. (dBm)	0
	Tot. Rad. Pwr. (dBm)	-3,45078
	Peak EIRP (dBm)	1,14912
	Directivity (dBi)	4,5999
	Efficiency (dB)	-3,45078
	Efficiency (%)	45,1775
	Gain (dBi)	1,14912

Plot 3: Mid channel, antenna diagram

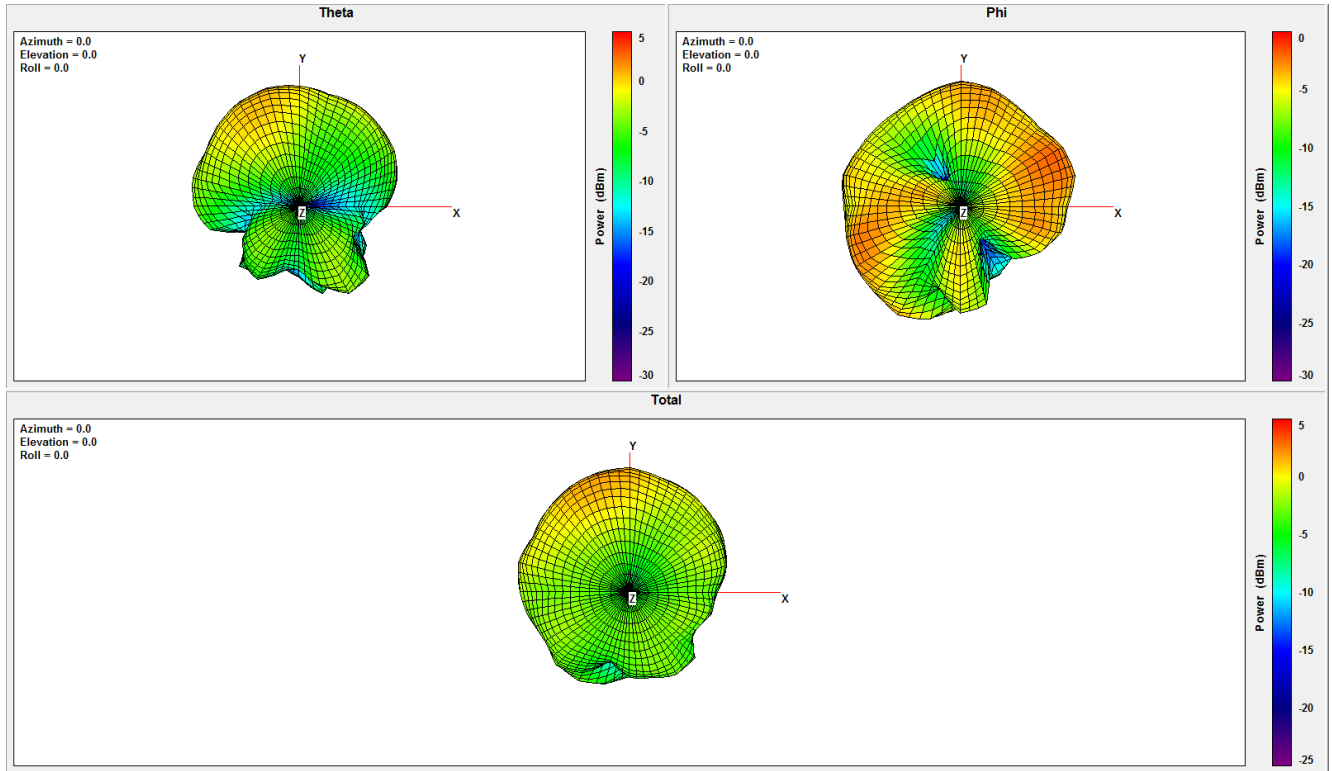

Plot 4: Mid channel – Table of Results

Total	Point Values	
	Ant. Port Input Pwr. (dBm)	0
	Tot. Rad. Pwr. (dBm)	-3,00047
	Peak EIRP (dBm)	1,94584
	Directivity (dBi)	4,9463
	Efficiency (dB)	-3,00047
	Efficiency (%)	50,1133
	Gain (dBi)	1,94584

Plot 5: Highest channel, antenna diagram

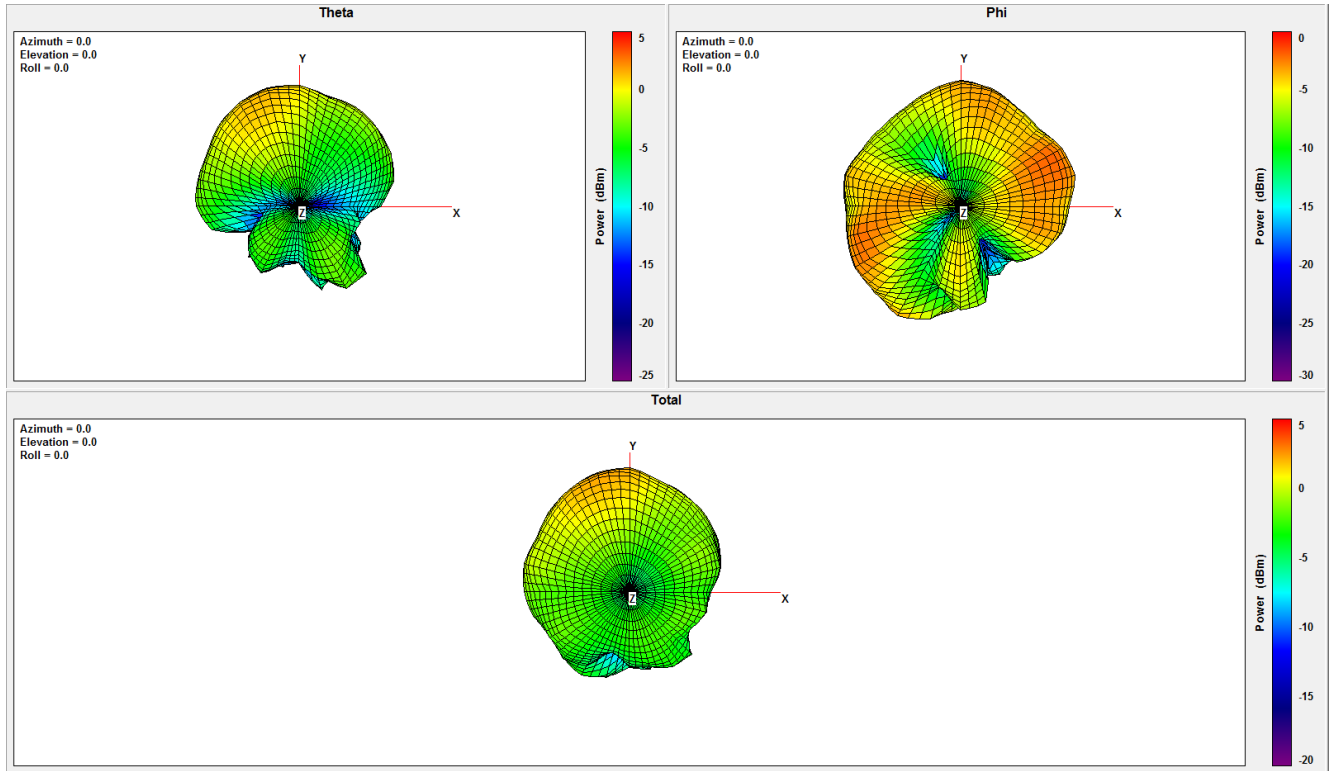

Plot 6: Highest channel – Table of Results

Total	Point Values	
	Ant. Port Input Pwr. (dBm)	0
	Tot. Rad. Pwr. (dBm)	-2,65901
	Peak EIRP (dBm)	2,40792
	Directivity (dBi)	5,06693
	Efficiency (dB)	-2,65901
	Efficiency (%)	54,2125
	Gain (dBi)	2,40792

11.2 Identify worst case data rate

Measurement:

All modes of the module will be measured with an average power meter or spectrum analyzer to identify the maximum transmission power.

In further tests only the identified worst case modulation scheme or bandwidth will be measured and this mode is used as representative mode for all other modulation schemes.

Additional the band edge compliance test will be performed in the lowest and highest modulation scheme.

Measurement parameters:

Measurement parameter	
Detector:	Peak
Sweep time:	Auto
Resolution bandwidth:	3 MHz
Video bandwidth:	3 MHz
Trace mode:	Max hold
Test setup:	See sub clause 6.5 – A
Measurement uncertainty:	-/-

Results:

Modulation	Modulation scheme / bandwidth
DSSS / b – mode	1 Mbit/s
OFDM / g – mode	6 Mbit/s
OFDM / n HT20 – mode	MCS0
OFDM / n HT40 – mode	MCS0

11.3 Maximum output power

Description:

Measurement of the maximum output power conducted and radiated. The measurements are performed using the data rate producing the highest conducted output power.

Measurement:

Measurement parameter	
According to DTS clause: 9.1.2	
Peak power meter	
Test setup:	See sub clause 6.5 – B
Measurement uncertainty	See sub clause 8

Limits:

FCC	IC
Conducted: 1.0 W – Antenna gain with max. 6 dBi	

Results:

Frequency	Maximum Output Power [dBm]		
	2412 MHz	2437 MHz	2462 MHz
Output power conducted DSSS / b – mode	13.1	12.3	12.7
Output power conducted OFDM / g – mode	7.8	10.1	7.6
Output power conducted OFDM / n HT20 – mode	6.4	9.4	6.5
Frequency	2422 MHz	2437 MHz	2452 MHz
Output power conducted OFDM / n HT40 – mode	7.0	9.7	7.1

11.4 Duty cycle

Measurement:

Timing of the transmitter.

Measurement parameters:

Measurement parameter	
Detector:	Peak
Sweep time:	Depends on the signal see plot
Resolution bandwidth:	10 MHz
Video bandwidth:	10 MHz
Trace mode:	Max hold
Test setup:	See sub clause 6.4 - A
Measurement uncertainty:	See sub clause 8

Limits:

FCC	IC
-/-	

Results:

T_{nom}	V_{nom}	lowest channel 2412 MHz	middle channel 2437 MHz	highest channel 2462 MHz
DSSS / b – mode		100.0 % / 0.00 dB	100.0 % / 0.00 dB	100.0 % / 0.00 dB
OFDM / g – mode		100.0 % / 0.00 dB	100.0 % / 0.00 dB	100.0 % / 0.00 dB
OFDM / n HT20 – mode		100.0 % / 0.00 dB	100.0 % / 0.00 dB	100.0 % / 0.00 dB
T_{nom}	V_{nom}	lowest channel 2422 MHz	middle channel 2437 MHz	highest channel 2452 MHz
OFDM / n HT40 – mode		100.0 % / 0.00 dB	100.0 % / 0.00 dB	100.0 % / 0.00 dB

11.5 Peak power spectral density

Description:

Measurement of the power spectral density of a digital modulated system. The measurement is repeated for both modulations at the lowest, middle and highest channel.

Measurement:

Measurement parameter	
According to DTS clause: 10.2	
Detector:	Positive Peak
Sweep time:	Auto
Resolution bandwidth:	100 kHz
Video bandwidth:	300 kHz
Span:	30 MHz
Trace mode:	Max hold (allow trace to fully stabilize)
Test setup:	See sub clause 6.5 – A
Measurement uncertainty	See sub clause 8

Limits:

FCC	IC
8 dBm / 3 kHz (conducted)	

Results:

Modulation	Peak power spectral density [dBm]		
	2412 MHz	2437 MHz	2462 MHz
Frequency			
DSSS / b – mode	3.8	3.5	3.6
OFDM / g – mode	-6.2	-3.3	-6.2
OFDM / n HT20 – mode	-7.2	-4.6	-7.4
Frequency	2422 MHz	2437 MHz	2452 MHz
OFDM / n HT40 – mode	-10.3	-7.7	-10.2

Plots: DSSS / b – mode

Plot 1: Lowest channel

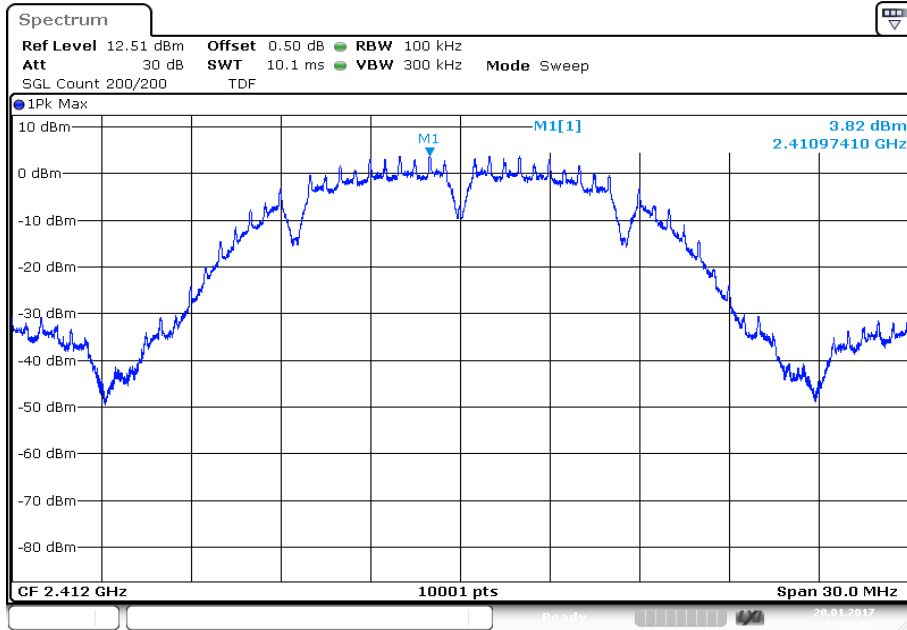

Date: 20.JAN.2017 14:29:02

Plot 2: Middle channel

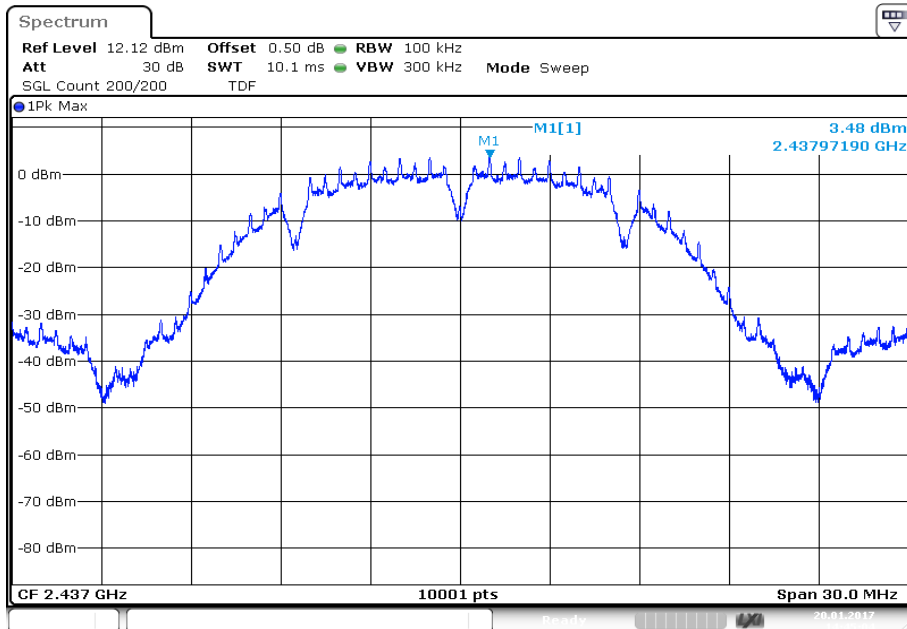

Date: 20.JAN.2017 14:45:04

Plot 3: Highest channel

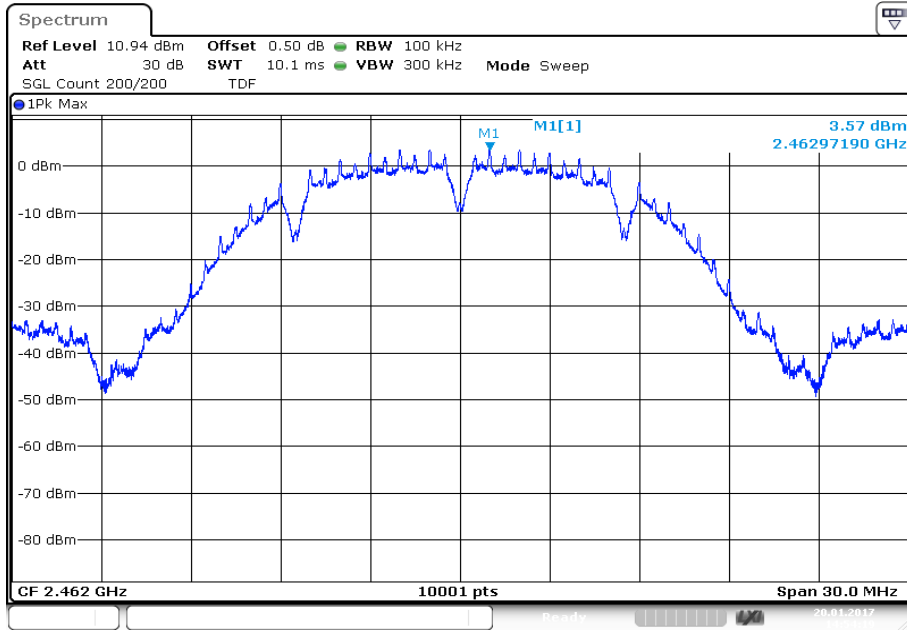

Date: 20.JAN.2017 14:54:19

Plots: OFDM / g – mode

Plot 1: Lowest channel

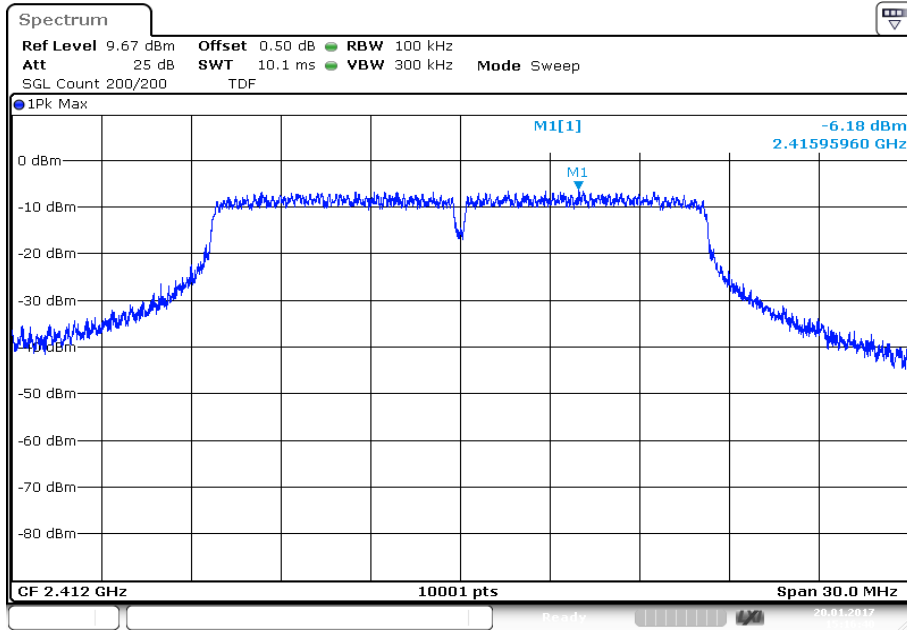

Plot 2: Middle channel

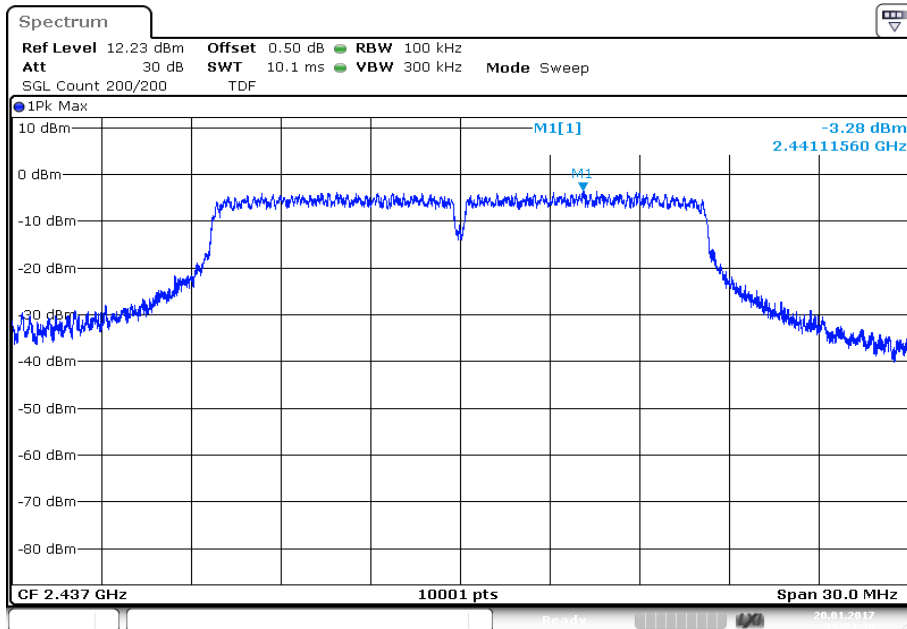

Plot 3: Highest channel

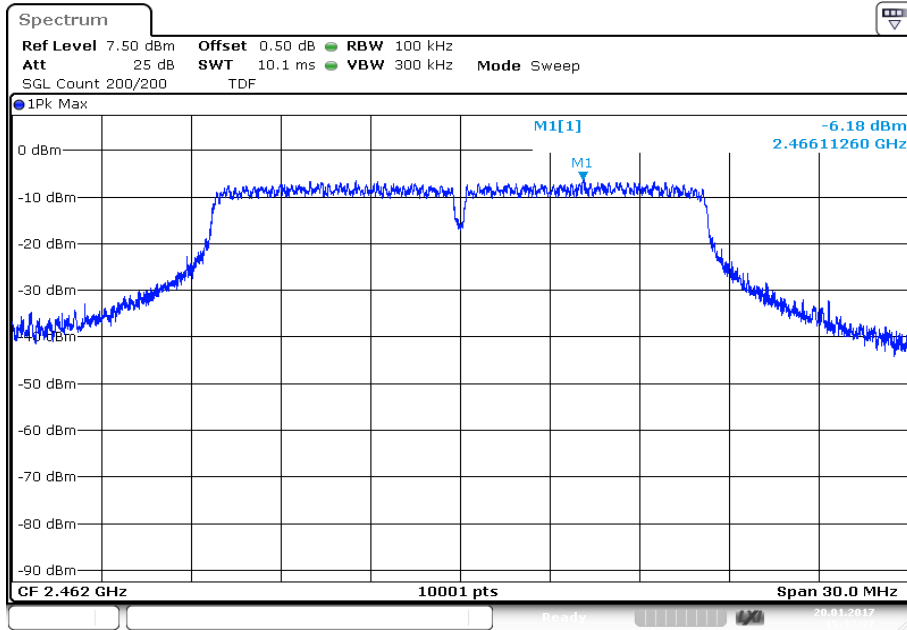

Date: 20.JAN.2017 15:32:38

Plots: OFDM / n HT20 – mode

Plot 1: Lowest channel

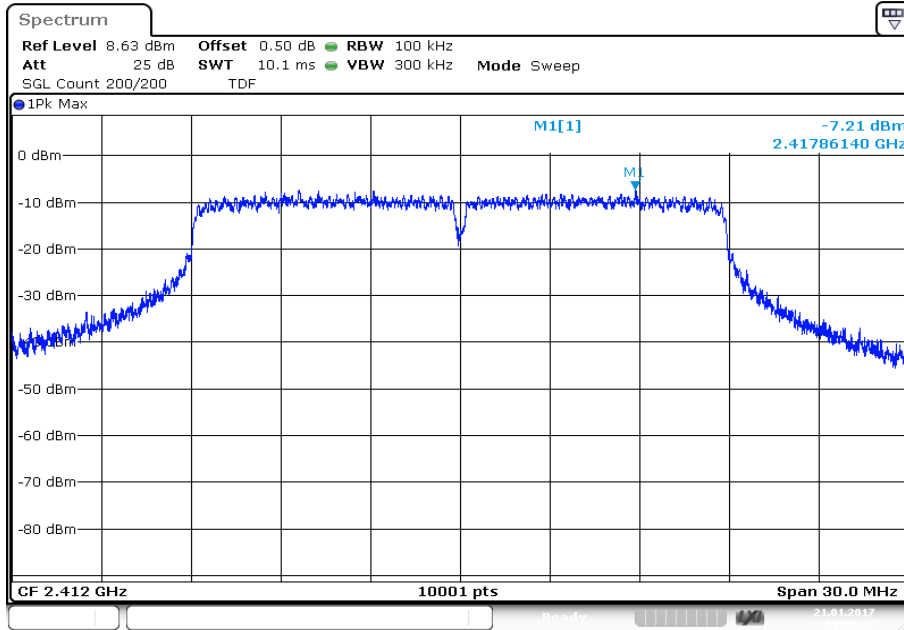

Plot 2: Middle channel

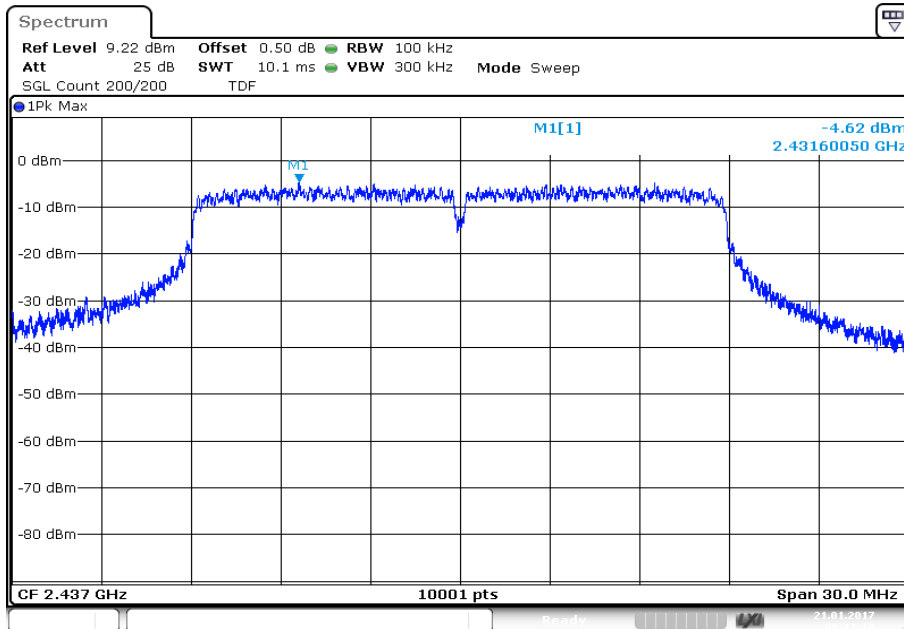

Plot 3: Highest channel

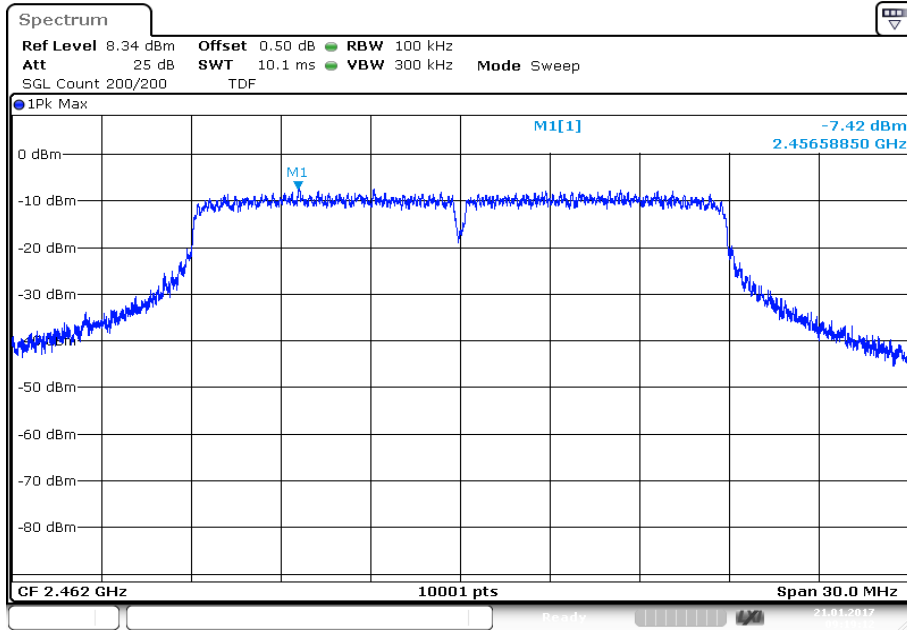

Date: 21.JAN.2017 09:19:12

Plots: OFDM / n HT40 – mode

Plot 1: Lowest channel

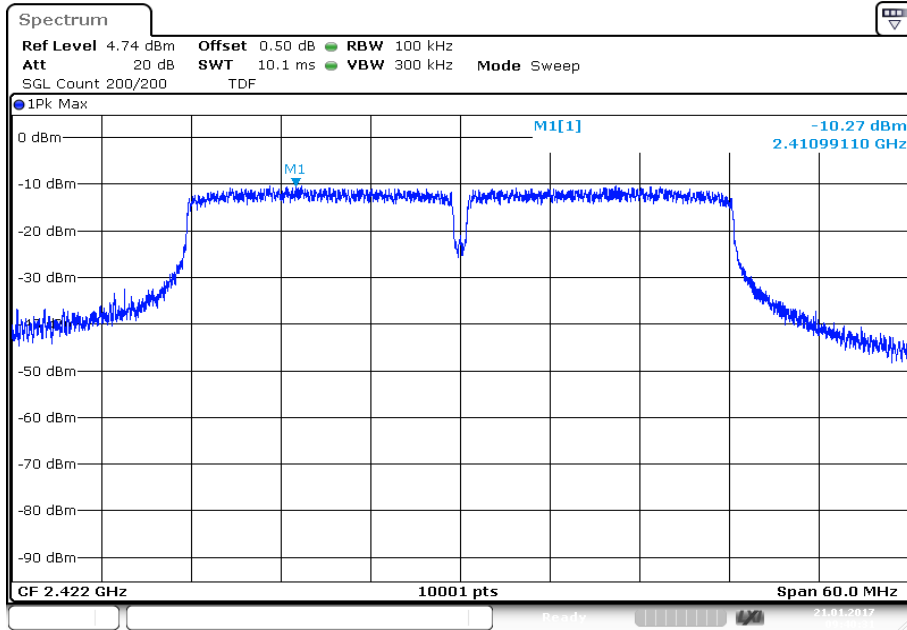

Plot 2: Middle channel

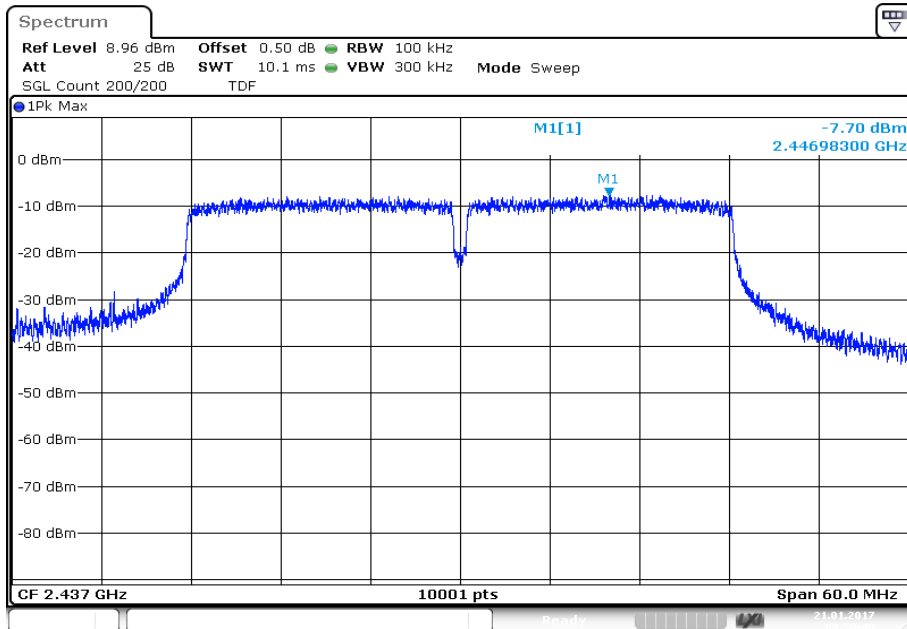

Plot 3: Highest channel

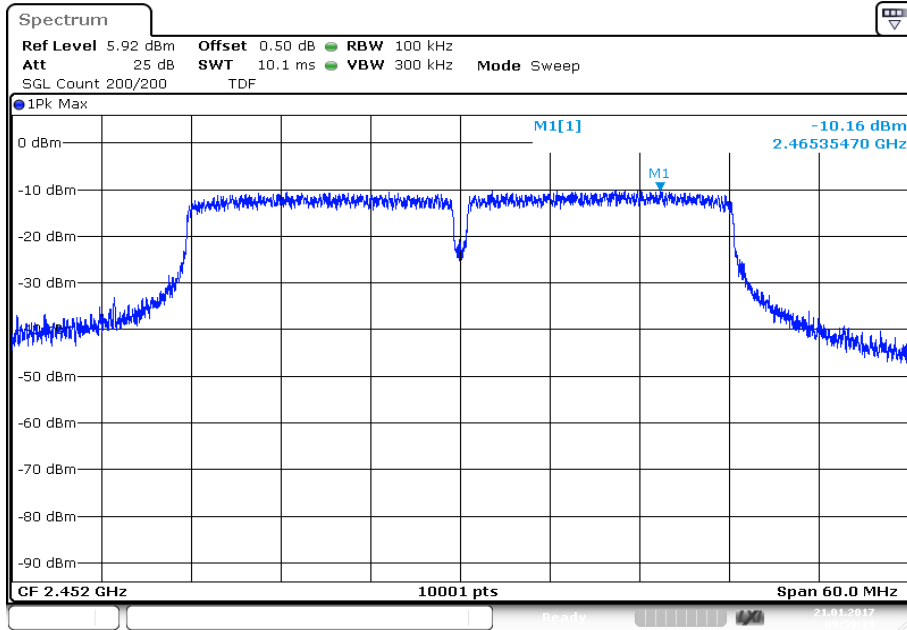

Date: 21.JAN.2017 09:59:19

11.6 6 dB DTS bandwidth

Description:

Measurement of the 6 dB bandwidth of the modulated signal.

Measurement:

Measurement parameter	
According to DTS clause: 8.1	
Detector:	Peak
Sweep time:	Auto
Resolution bandwidth:	100 kHz
Video bandwidth:	500 kHz
Span:	30 MHz / 50 MHz
Trace mode:	Single count with 200 counts
Test setup:	See sub clause 6.5 – A
Measurement uncertainty	See sub clause 8

Limits:

FCC	IC
Systems using digital modulation techniques may operate in the 2400–2483.5 MHz band. The minimum 6 dB bandwidth shall be at least 500 kHz.	

Results:

Frequency	6 dB DTS bandwidth [kHz]		
	2412 MHz	2437 MHz	2462 MHz
DSSS / b – mode	10085	10082	10082
OFDM / g – mode	16537	16537	16531
OFDM / n HT20 – mode	17647	17764	17758
Frequency	2422 MHz	2437 MHz	2452 MHz
OFDM / n HT40 – mode	36434	36345	36464

Plots: DSSS / b – mode

Plot 1: Lowest channel

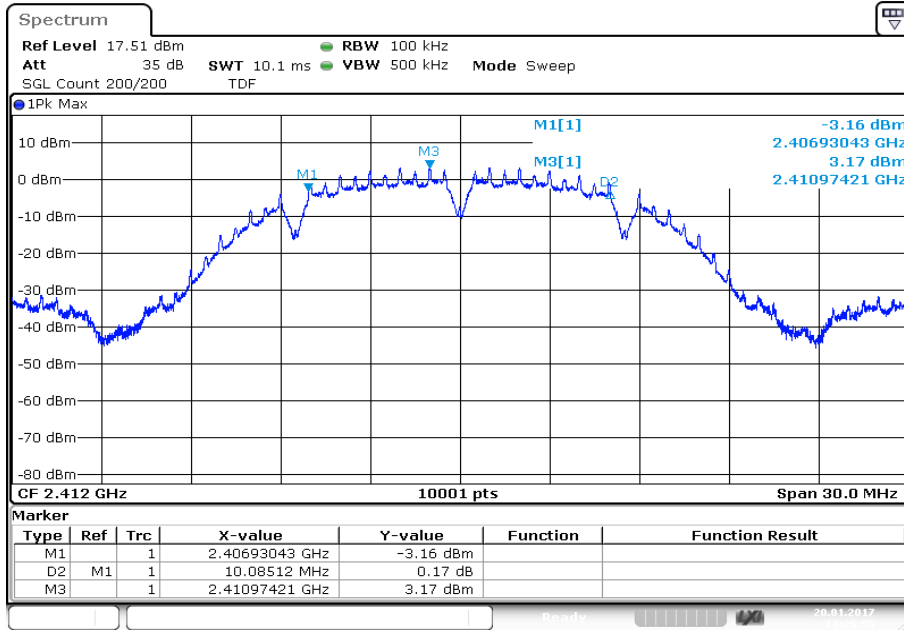

Date: 20. JAN. 2017 14:26:55

Plot 2: Middle channel

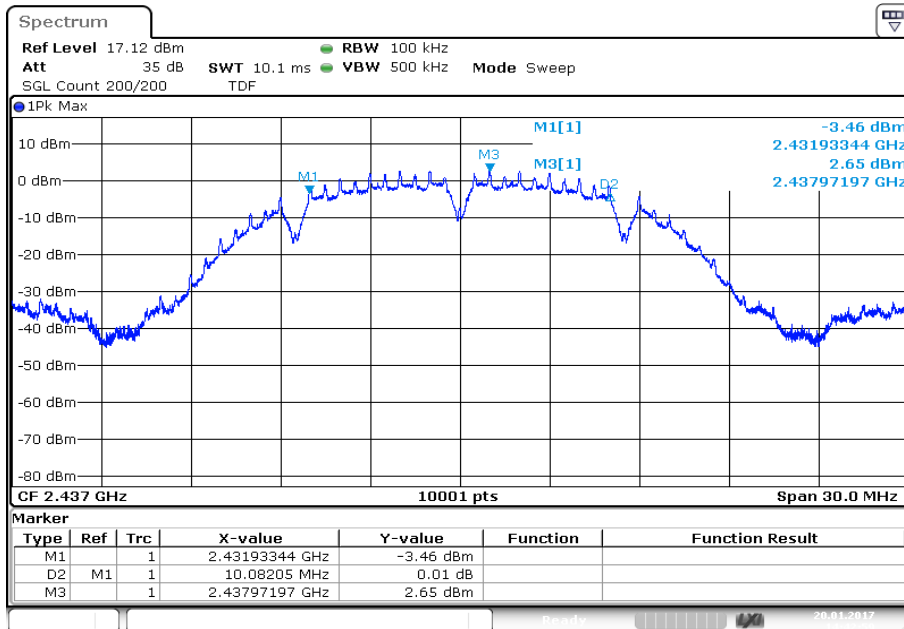

Date: 20. JAN. 2017 14:42:59

Plot 3: Highest channel

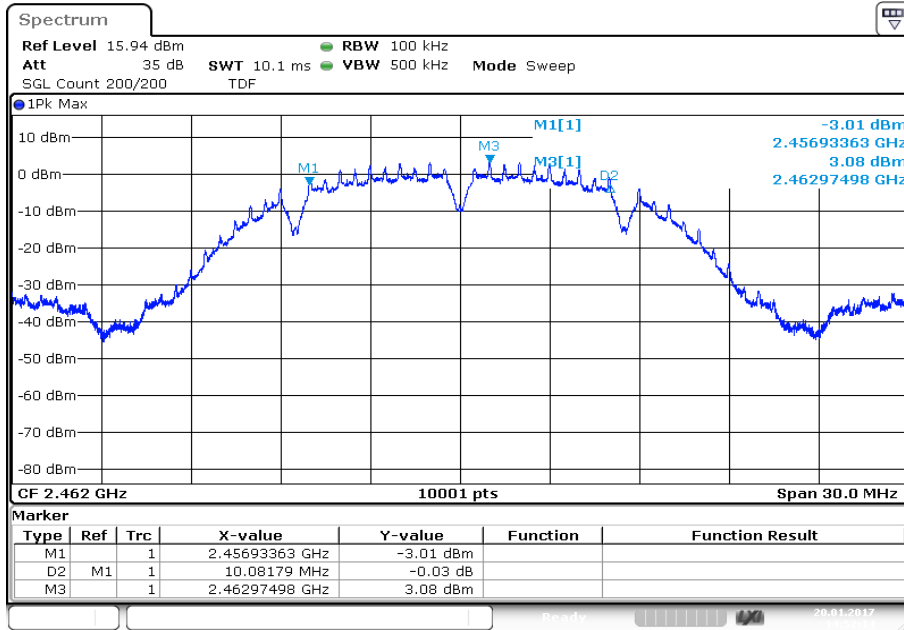

Date: 20.JAN.2017 14:52:14

Plots: OFDM / g – mode

Plot 1: Lowest channel

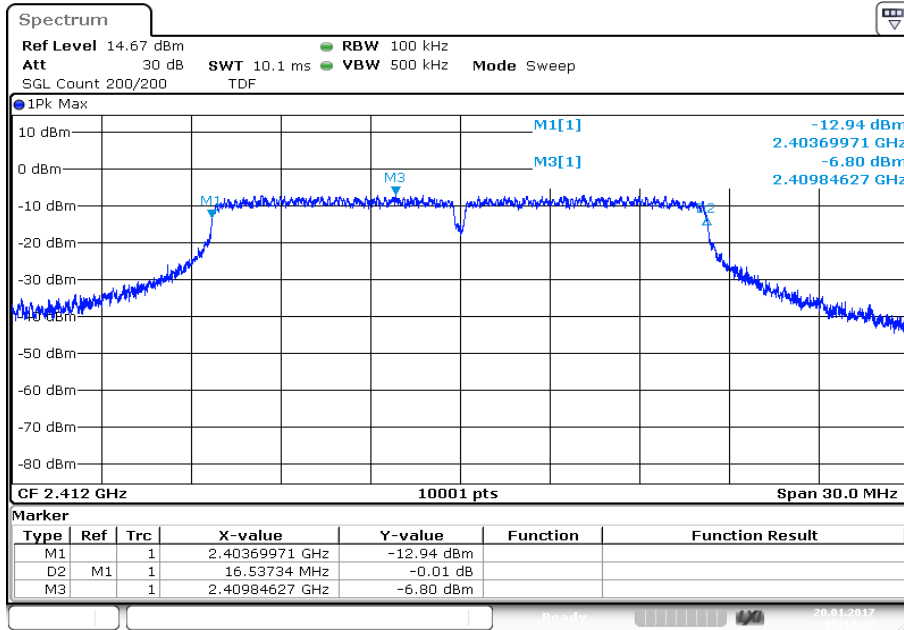

Plot 2: Middle channel

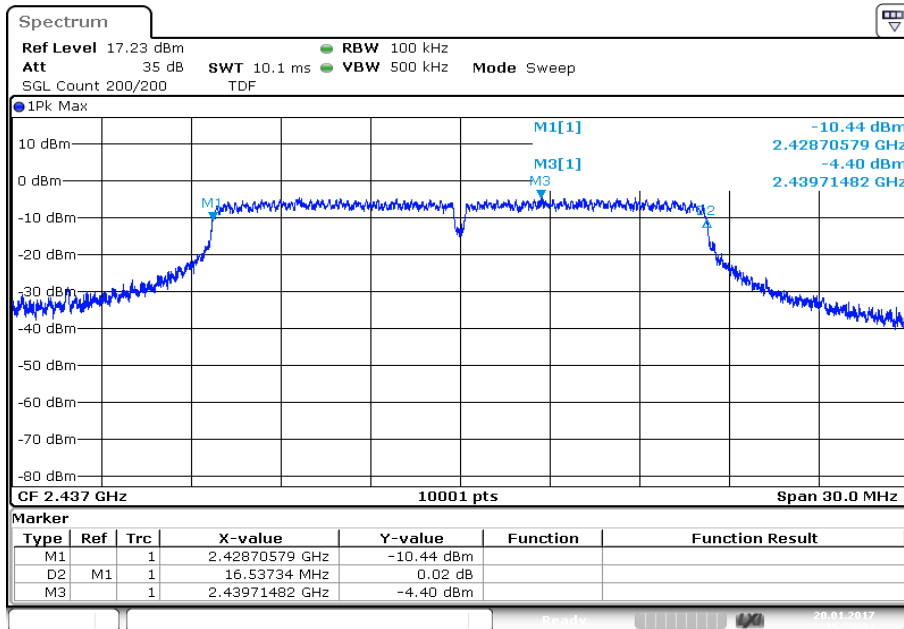

Plot 3: Highest channel

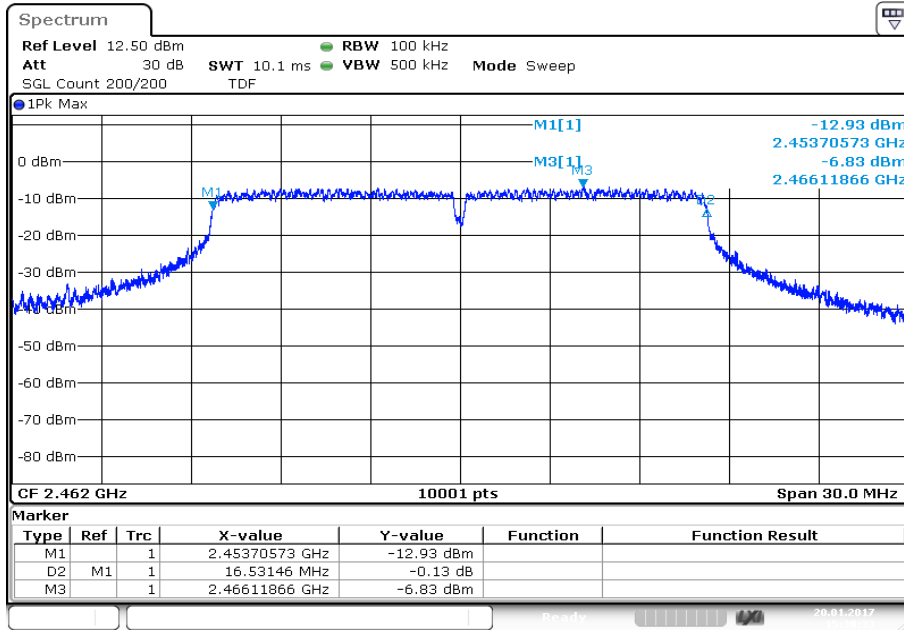

Plots: OFDM / n HT20 – mode

Plot 1: Lowest channel

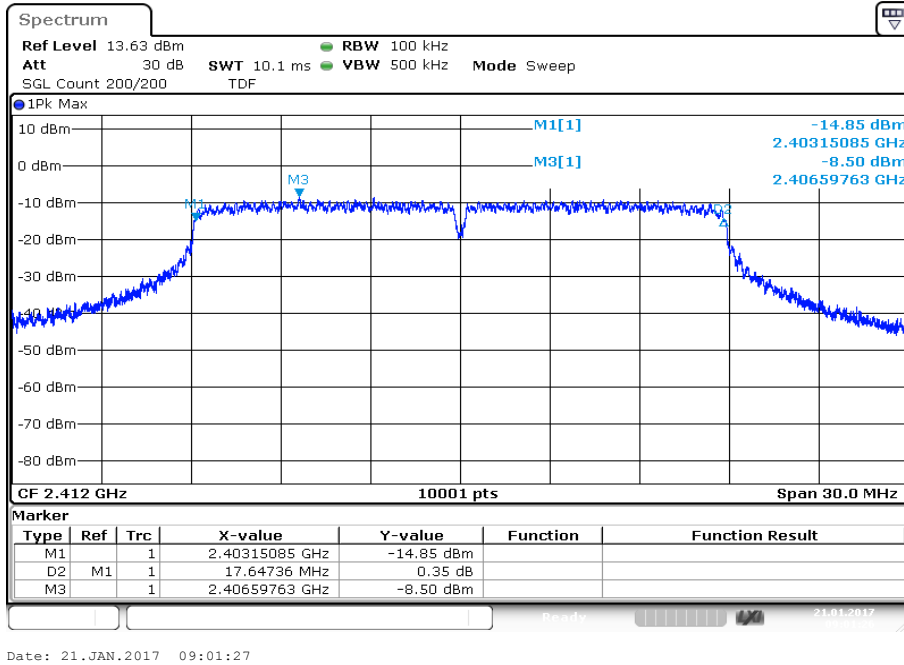

Plot 2: Middle channel

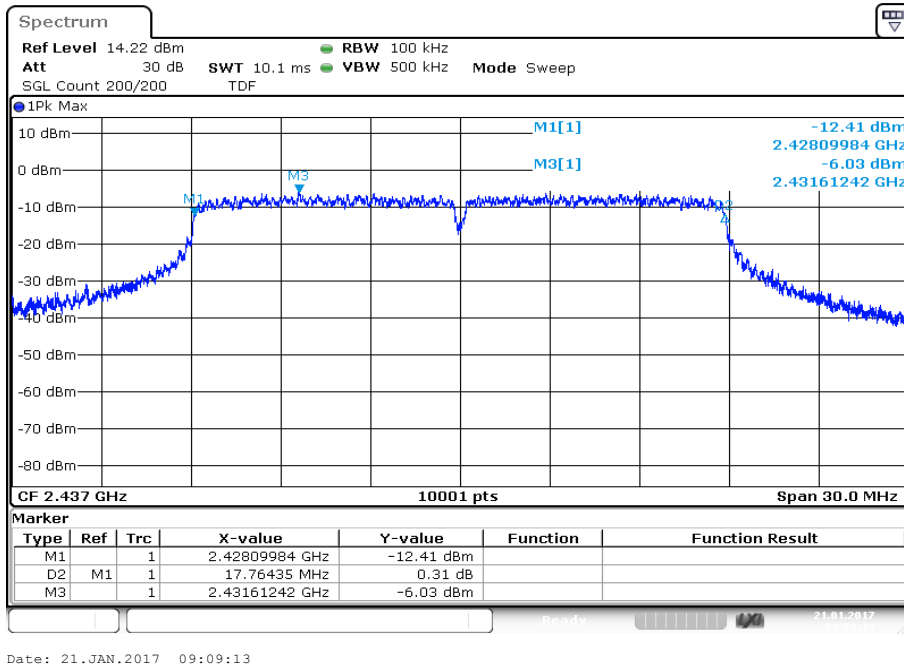

Plot 3: Highest channel

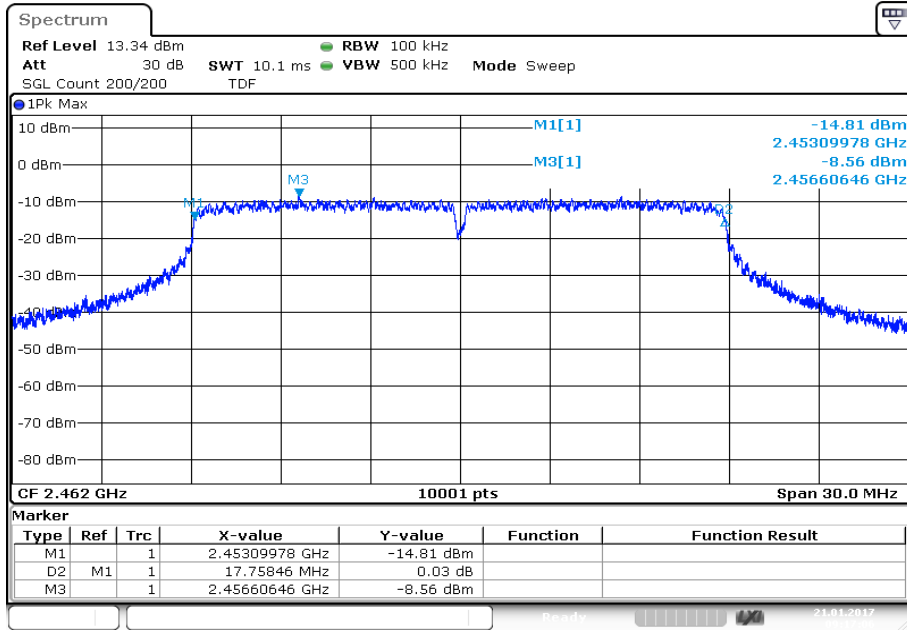

Date: 21.JAN.2017 09:17:06

Plots: OFDM / n HT40 – mode

Plot 1: Lowest channel

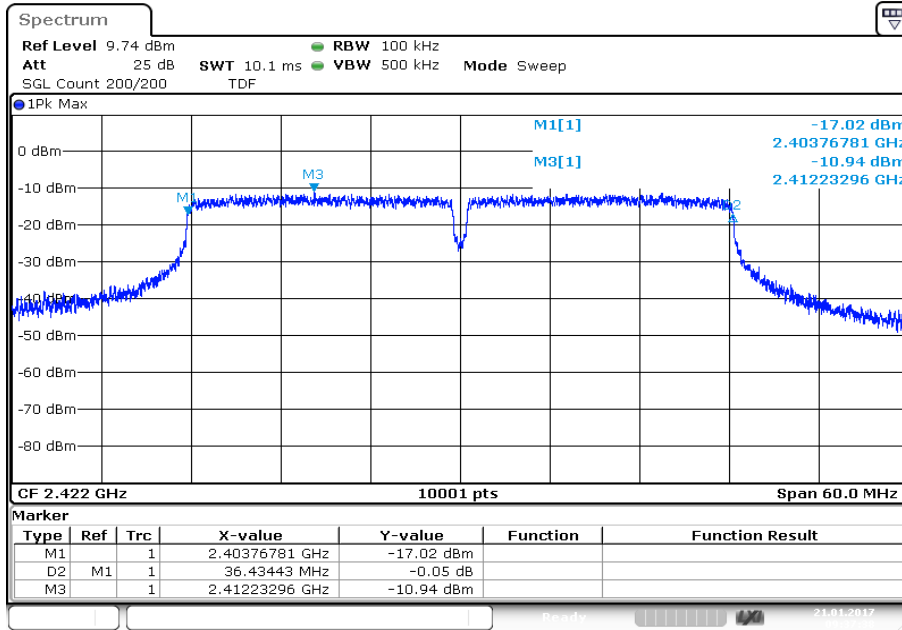

Plot 2: Middle channel

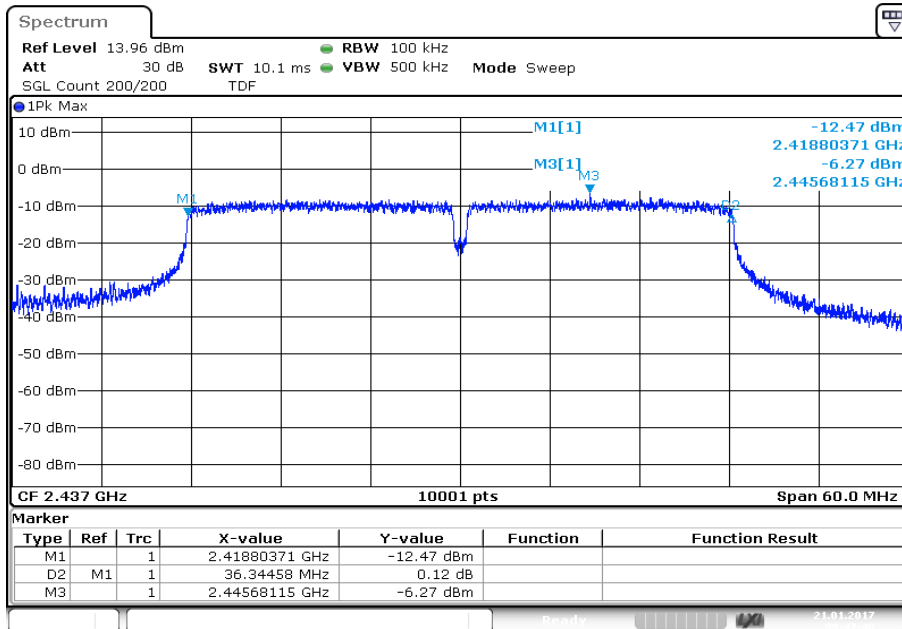

Plot 3: Highest channel

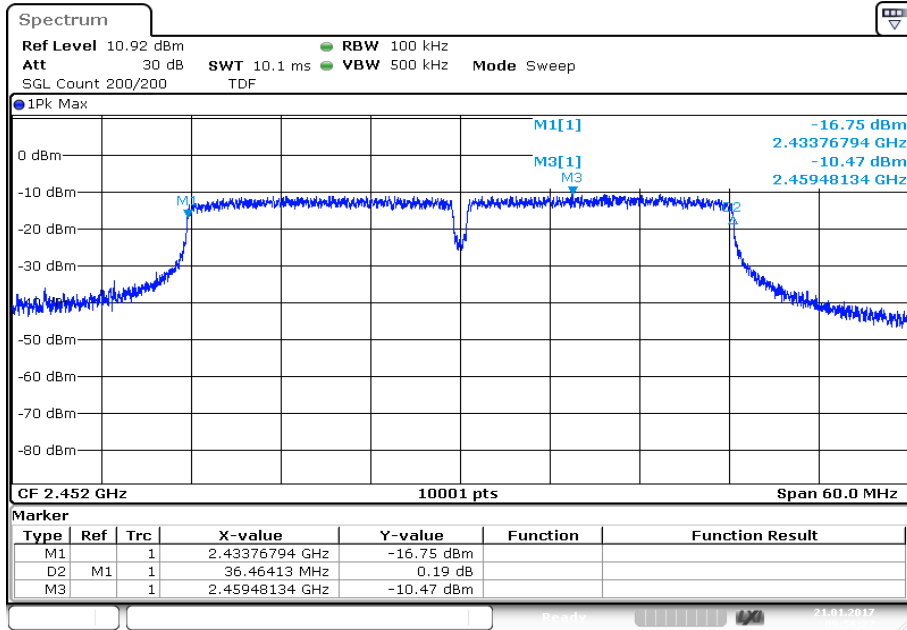

11.7 Occupied bandwidth – 99% emission bandwidth

Description:

Measurement of the 99% bandwidth of the modulated signal acc. RSS-GEN.

Measurement:

Measurement parameter	
Detector:	Peak
Sweep time:	Auto
Resolution bandwidth:	300 kHz / 1 MHz
Video bandwidth:	1 MHz / 3 MHz
Span:	30 MHz / 60 MHz
Measurement procedure:	Measurement of the 99% bandwidth using the integration function of the analyzer
Trace mode:	Single count with 200 counts
Test setup:	See sub clause 6.5 – A
Measurement uncertainty	See sub clause 8

Usage:

-/-	IC
OBW is necessary for Emission Designator	

Results:

Modulation	99% bandwidth [kHz]		
	2412 MHz	2437 MHz	2462 MHz
Frequency			
DSSS / b – mode	14150	14144	14099
OFDM / g – mode	16915	16906	16876
OFDM / n HT20 – mode	17962	18001	17980
Frequency	2422 MHz	2437 MHz	2452 MHz
OFDM / n HT40 – mode	37454	37466	37496

Plots: DSSS / b – mode

Plot 1: Lowest channel

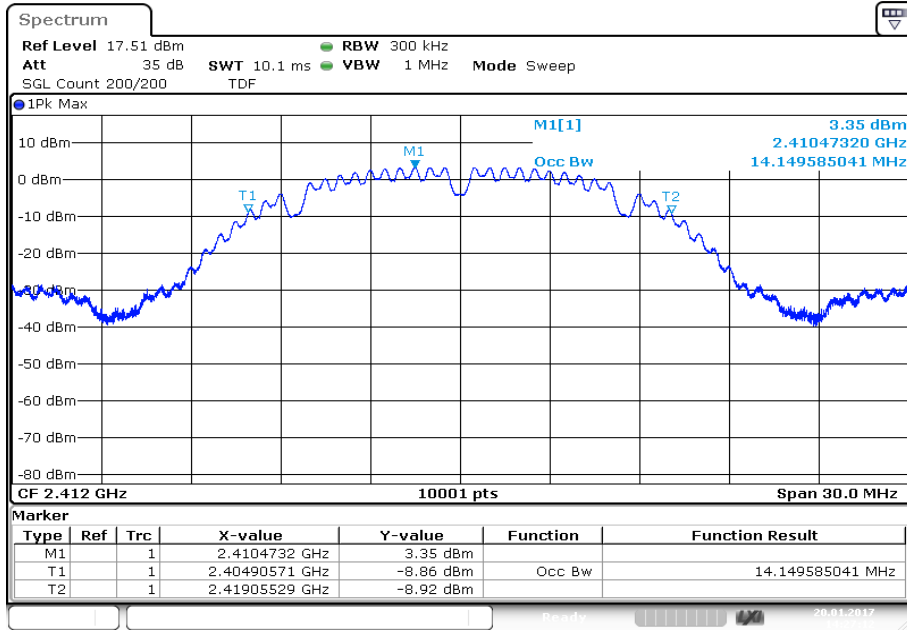

Plot 2: Middle channel

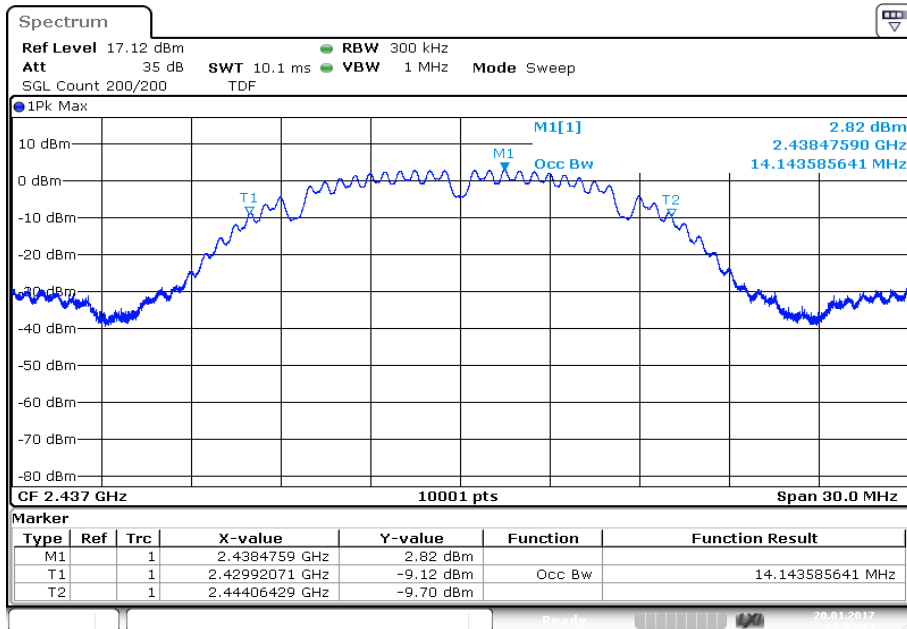

Plot 3: Highest channel

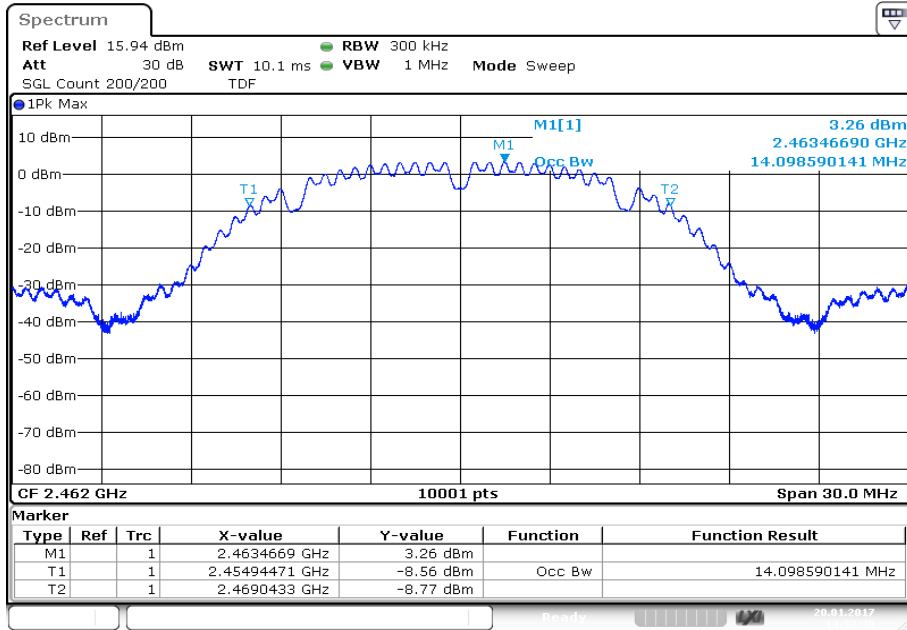

Date: 20.JAN.2017 14:52:30

Plots: OFDM / g – mode

Plot 1: Lowest channel

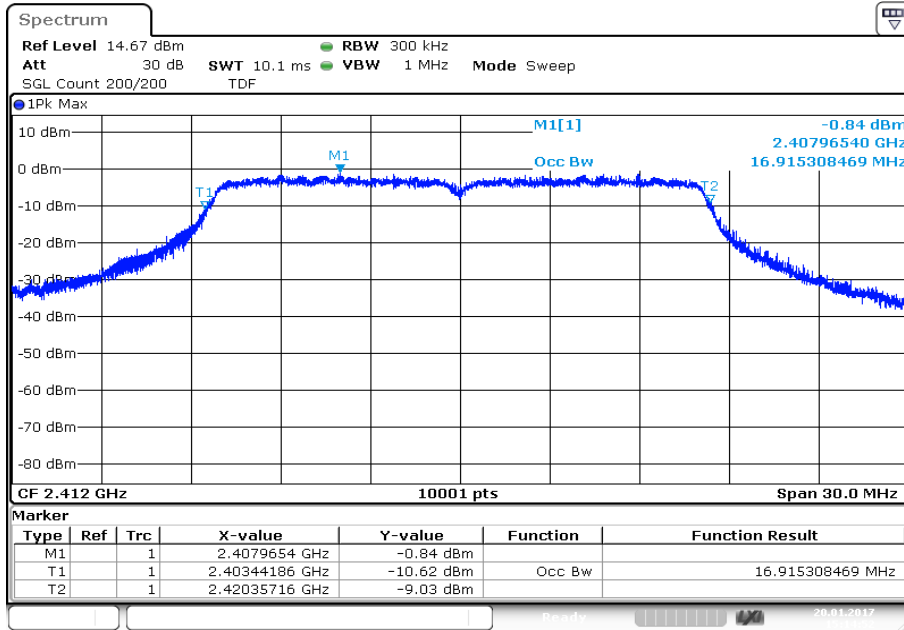

Date: 20.JAN.2017 15:14:53

Plot 2: Middle channel

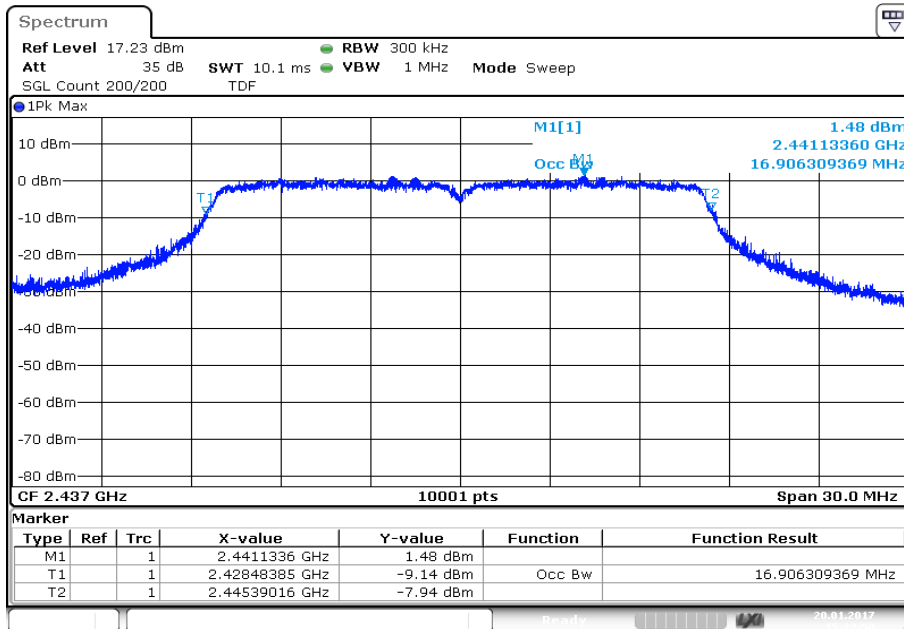

Date: 20.JAN.2017 15:22:50

Plot 3: Highest channel

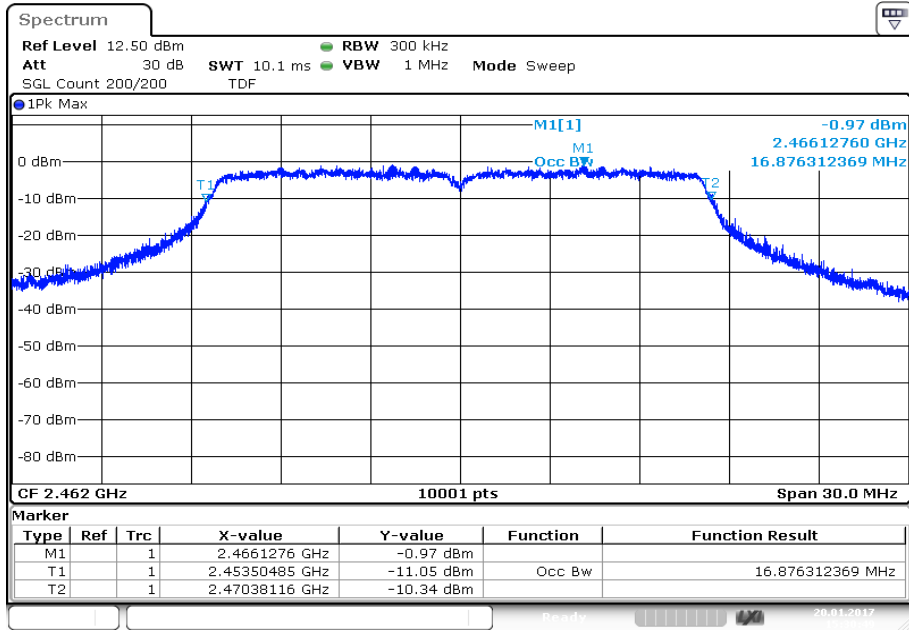

Date: 20.JAN.2017 15:30:49

Plots: OFDM / n HT20 – mode

Plot 1: Lowest channel

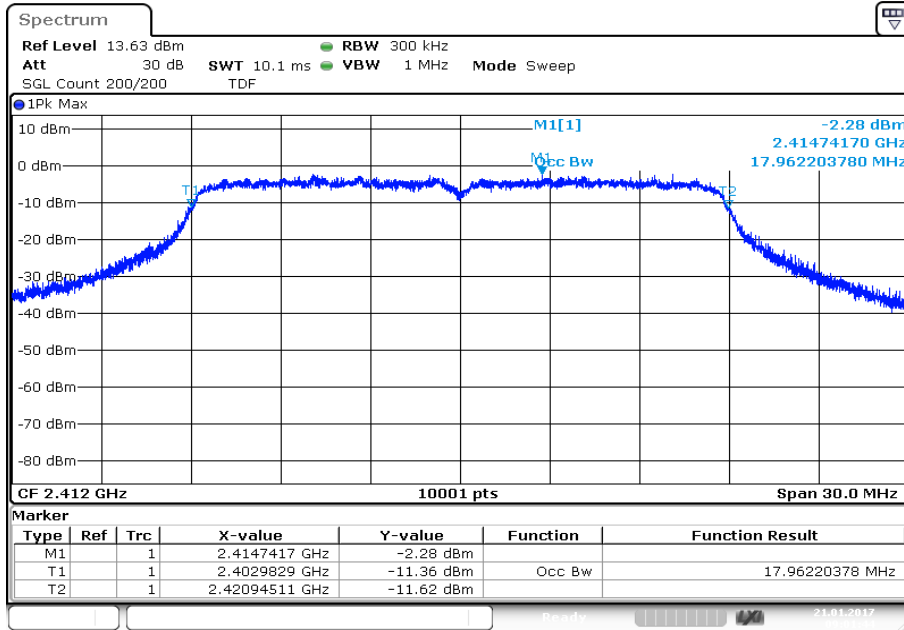

Plot 2: Middle channel

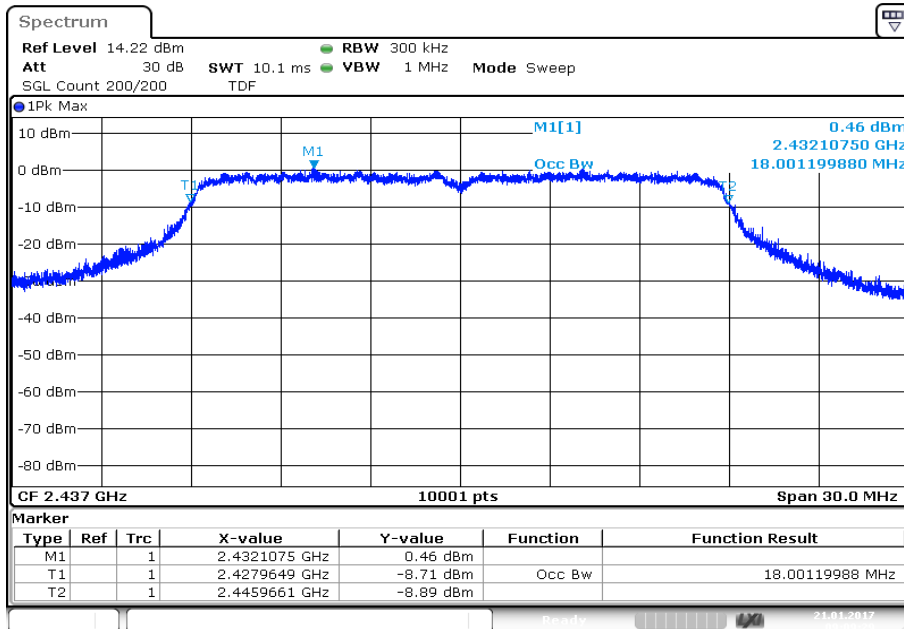

Plot 3: Highest channel

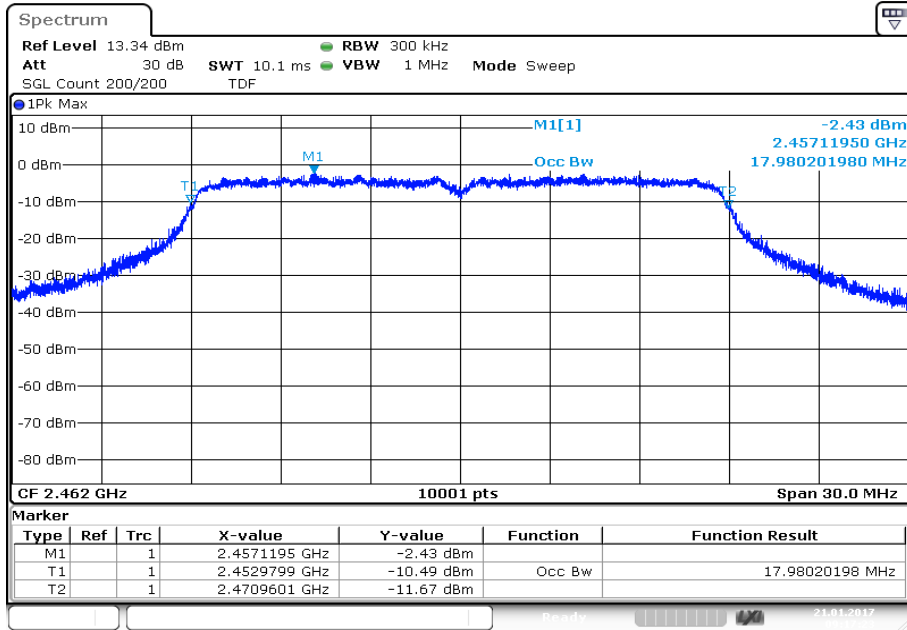

Date: 21.JAN.2017 09:17:23

Plots: OFDM / n HT40 – mode

Plot 1: Lowest channel

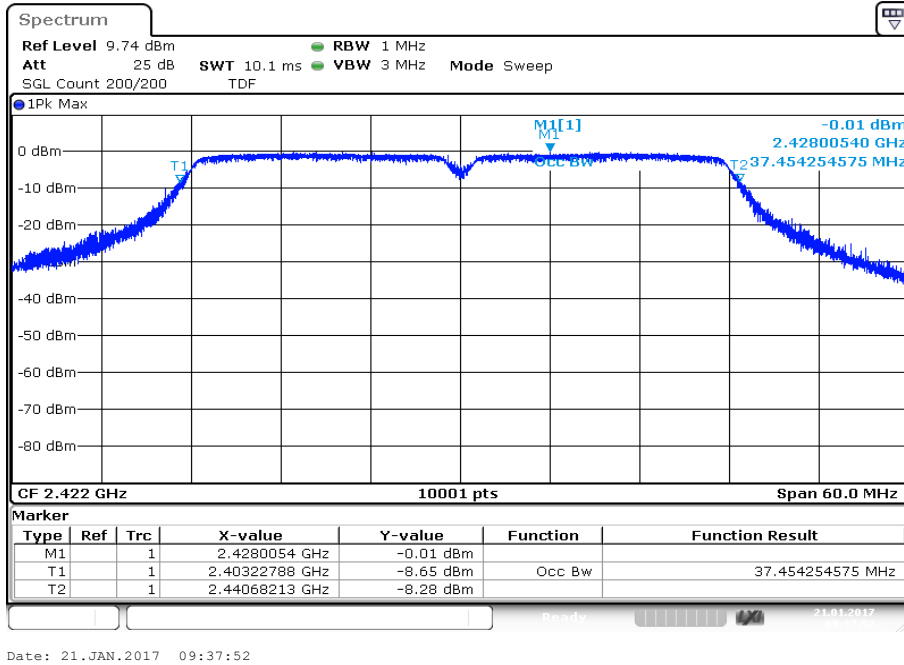

Plot 2: Middle channel

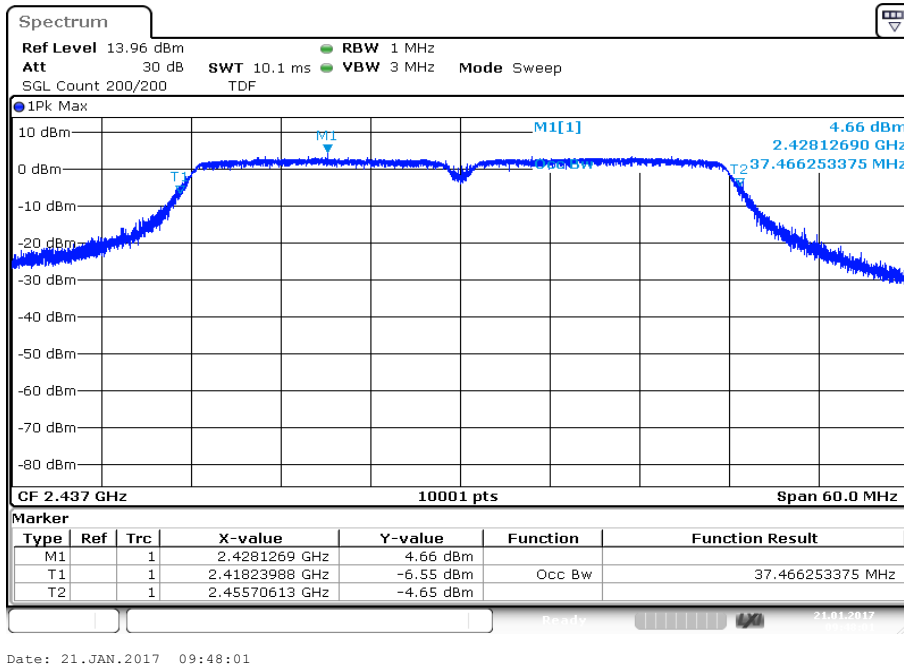

Plot 3: Highest channel

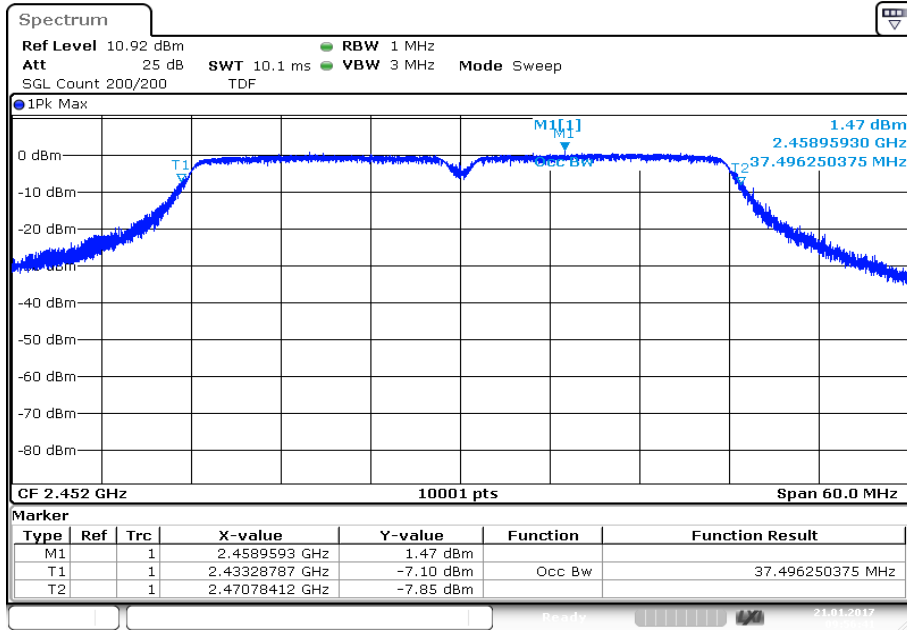

Date: 21.JAN.2017 09:56:41

11.8 Occupied bandwidth – 20 dB bandwidth

Description:

Measurement of the 20 dB bandwidth of the modulated carrier.

Measurement:

Measurement parameter	
Detector:	Peak
Sweep time:	Auto
Resolution bandwidth:	100 kHz
Video bandwidth:	500 kHz
Span:	30 MHz / 50 MHz
Trace mode:	Single count with min. 200 counts
Test setup:	See sub clause 6.5 – A
Measurement uncertainty	See sub clause 8

Usage:

-/-	IC
Within the used band!	

Results:

Modulation	20 dB bandwidth [kHz]		
	2412 MHz	2437 MHz	2462 MHz
Frequency			
DSSS / b – mode	16087	16060	16048
OFDM / g – mode	18958	18988	18685
OFDM / n HT20 – mode	19621	19813	19924
Frequency	2422 MHz	2437 MHz	2452 MHz
OFDM / n HT40 – mode	38798	39116	38858

Plots: DSSS / b – mode

Plot 1: Lowest channel

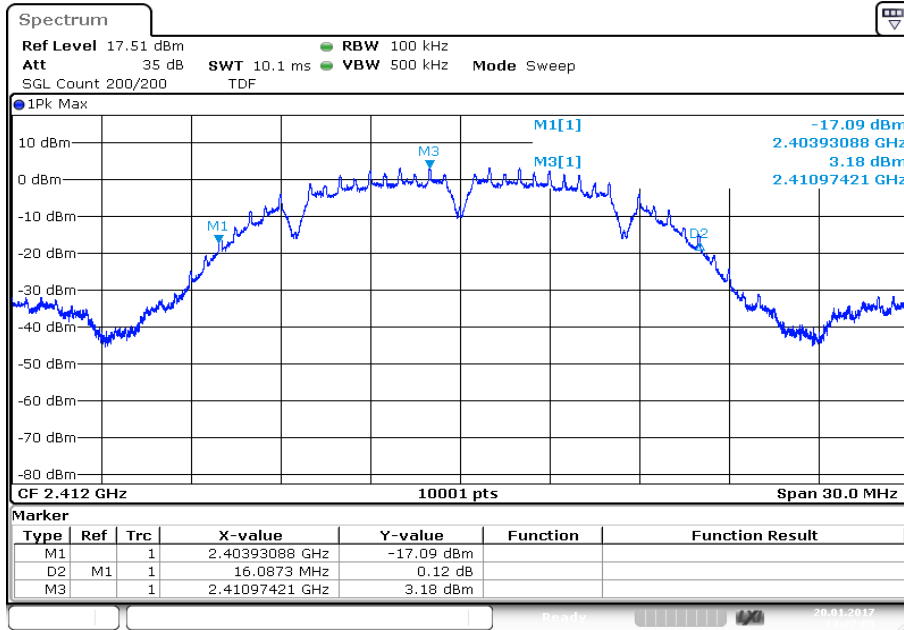

Plot 2: Middle channel

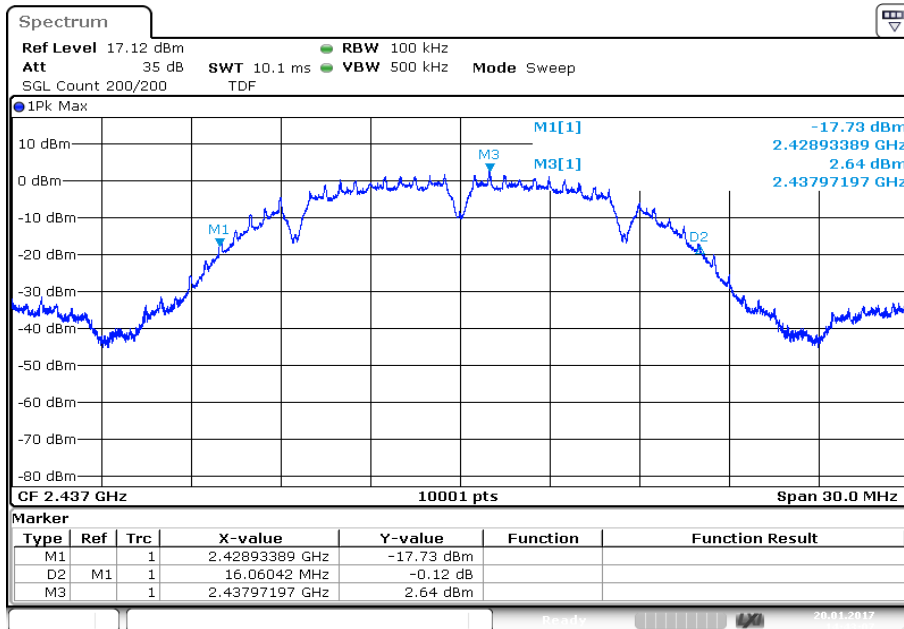

Plot 3: Highest channel

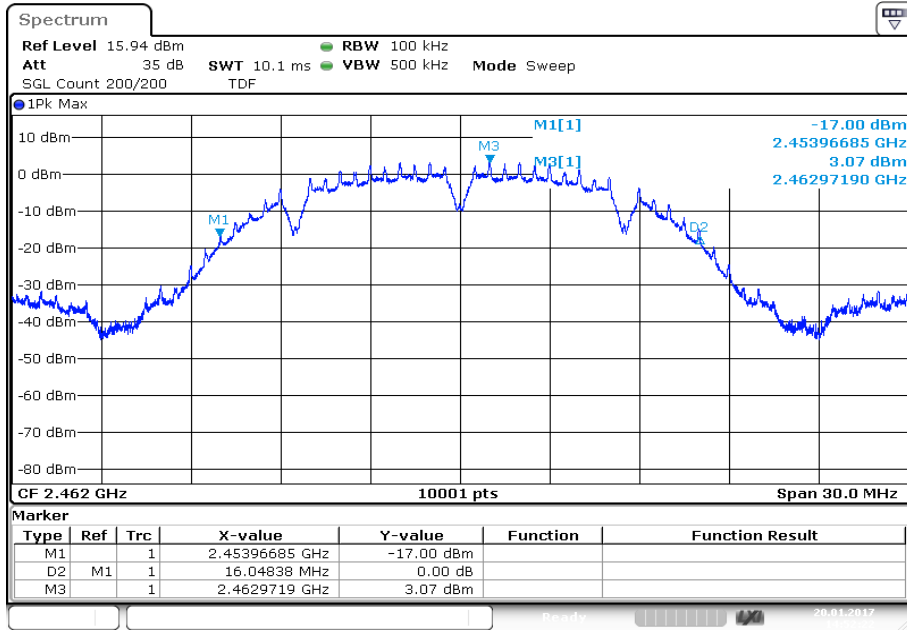

Date: 20.JAN.2017 14:52:23

Plots: OFDM / g – mode

Plot 1: Lowest channel

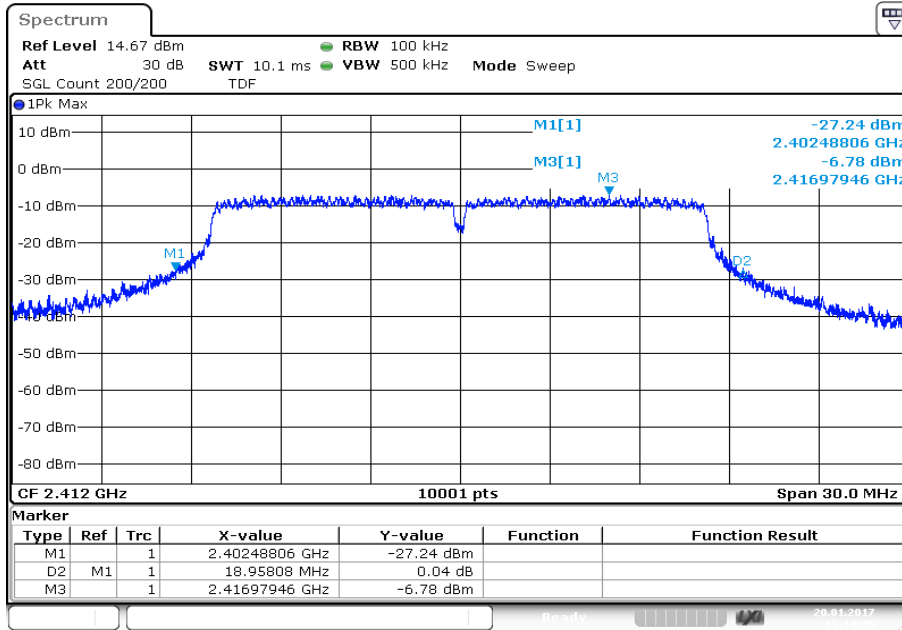

Plot 2: Middle channel

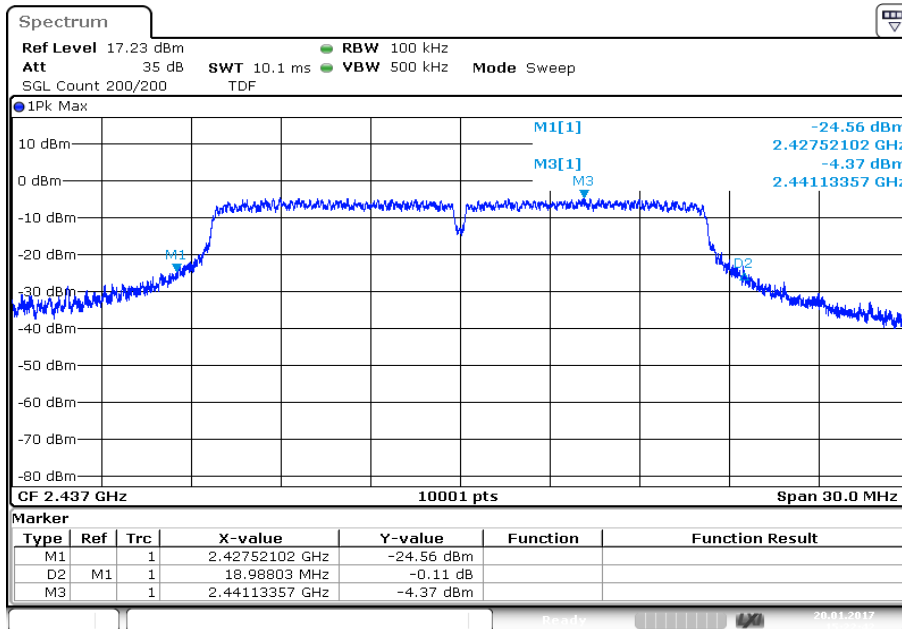

Plot 3: Highest channel

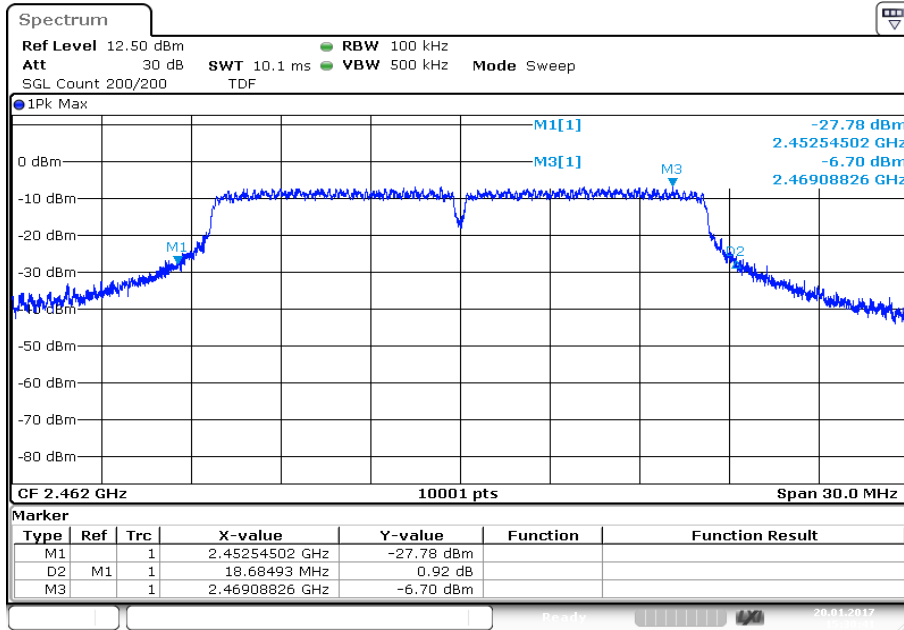

Date: 20.JAN.2017 15:30:41

Plots: OFDM / n HT20 – mode

Plot 1: Lowest channel

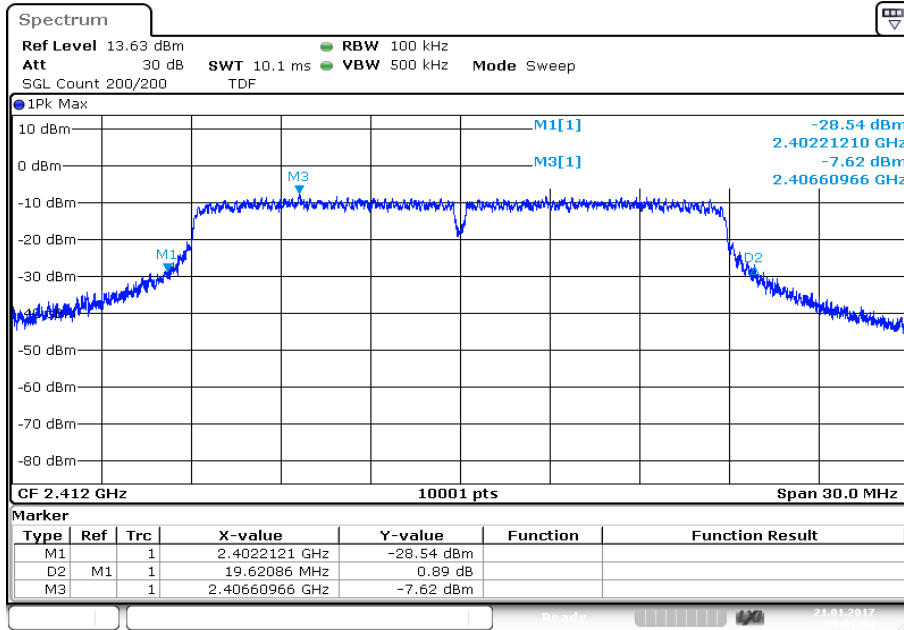

Plot 2: Middle channel

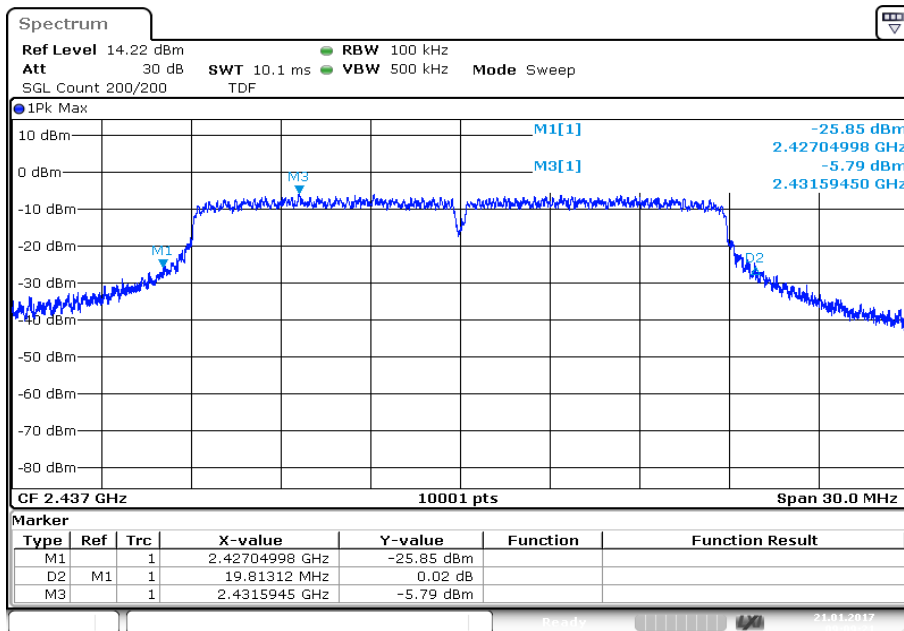

Plot 3: Highest channel

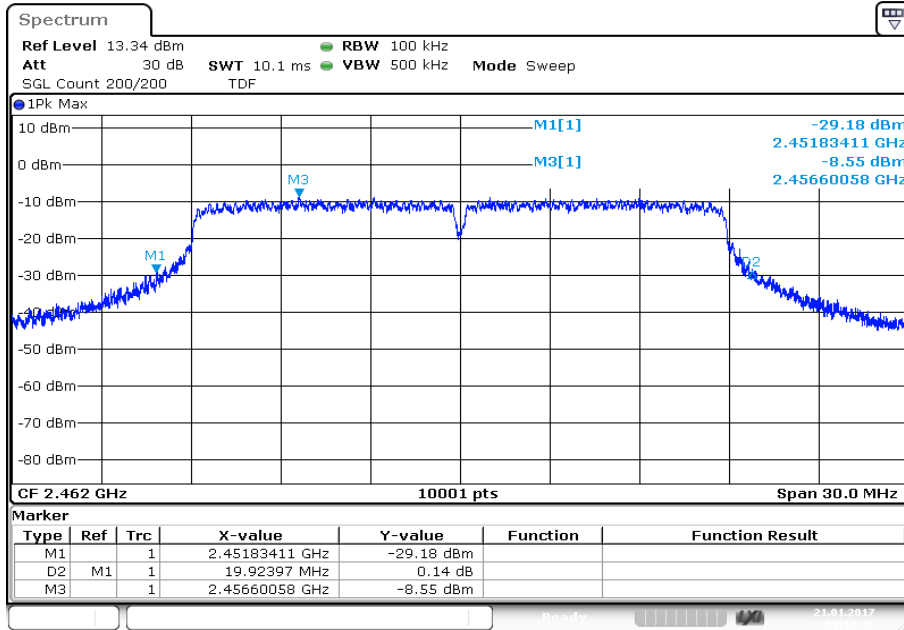

Date: 21.JAN.2017 09:17:15

Plots: OFDM / n HT40 – mode

Plot 1: Lowest channel

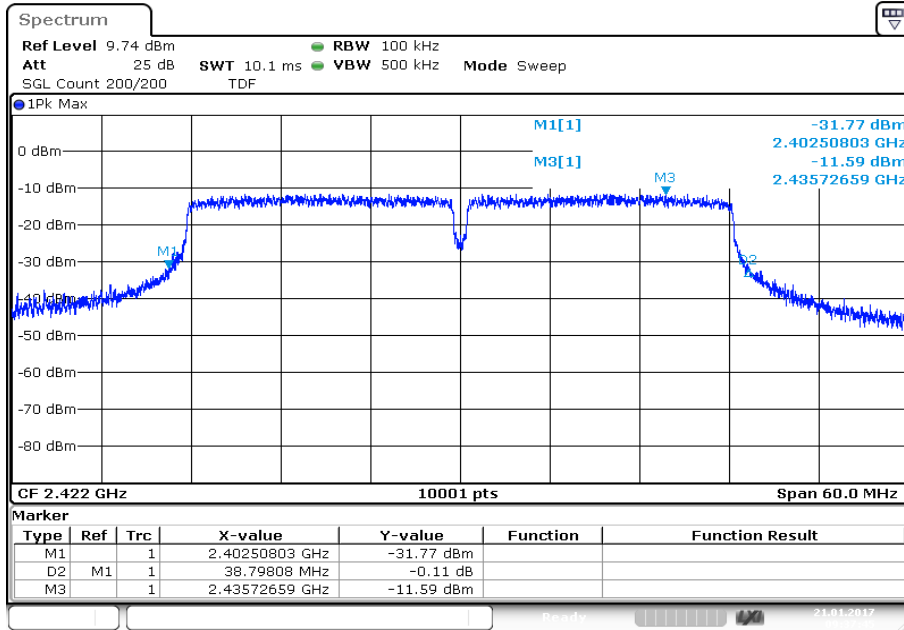

Plot 2: Middle channel

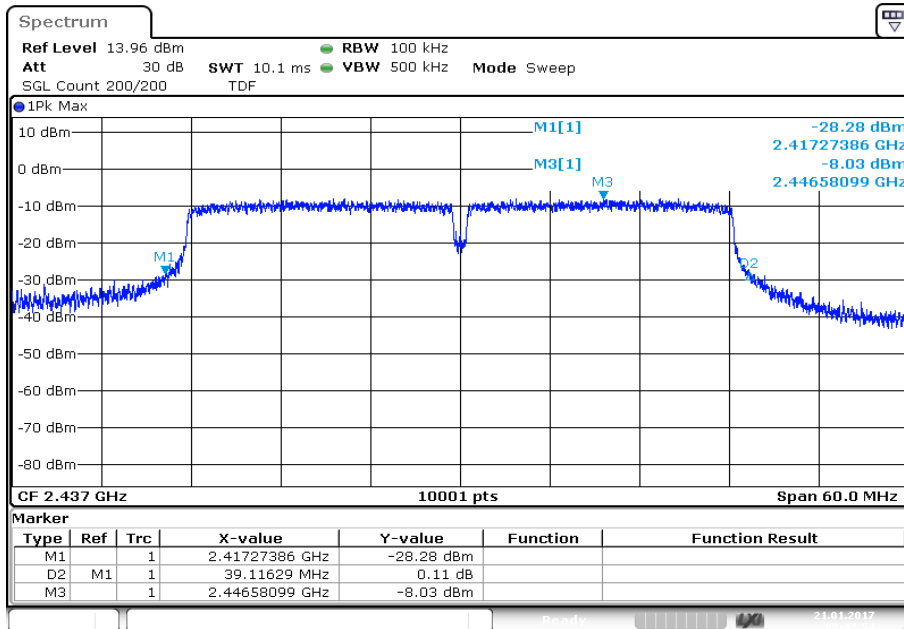

Plot 3: Highest channel

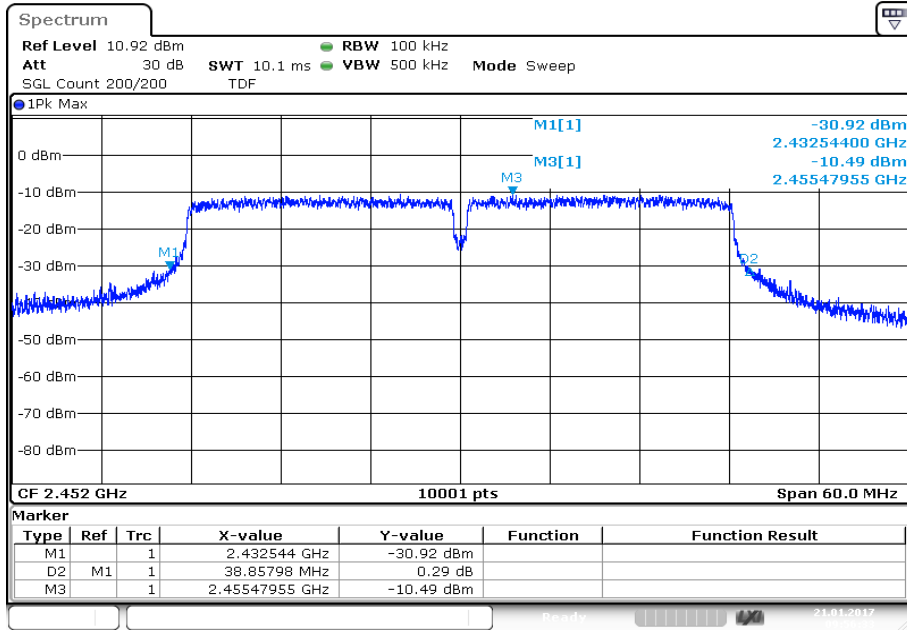

11.9 Band edge compliance conducted

Description:

Measurement of the radiated band edge compliance with a conducted test setup.

Measurement:

Measurement parameter for measurements	
According to DTS clause: 13.3.2 and clause 12.2.2	
Detector:	RMS
Sweep time:	Auto
Resolution bandwidth:	100 kHz
Video bandwidth:	300 kHz
Span:	Lower band edge: 2388 MHz to 2390 MHz (2 MHz) Upper band edge: 2483.5 MHz to 2485.5 MHz (2 MHz)
Trace mode:	Trace average with 200 counts
Test setup:	See sub clause 6.5 – A
Measurement uncertainty	See sub clause 8

Limits:

FCC	IC
-41.26 dBm	

Results:

Scenario	Band edge compliance [dBm] (gain calculation)			
	DSSS / b – mode	OFDM / g – mode	OFDM / n HT20 – mode	OFDM / n HT40 – mode
Modulation				
Max. lower band edge power conducted	-56.4	-48.6	-48.2	-43.8
Antenna gain (dBi)	1.2			
Max. lower band edge power radiated	-55.2	-47.4	-47.0	-42.6
Max. upper band edge power conducted	-56.4	-50.4	-50.3	-44.1
Antenna gain (dBi)	2.4			
Max. upper band edge power radiated	-54.0	-48.2	-47.9	-41.7

Results: (External antennas)

For the results of the radiated band edge compliance tests of all external antennas see “Appendix_to_1-2846/16-02-04-B”

Plots: DSSS / b – mode

Plot 1: Lower band edge

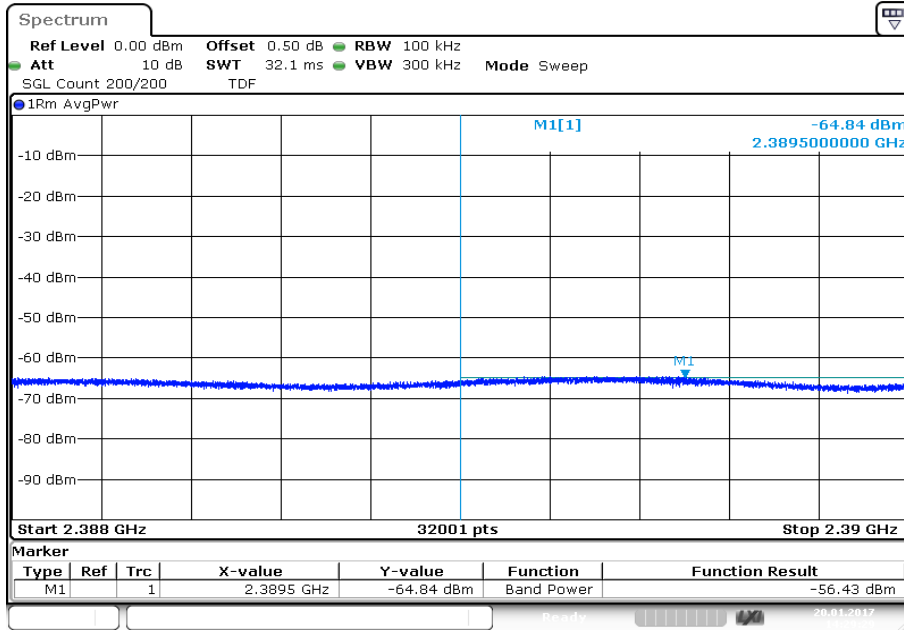

Date: 20.JAN.2017 14:29:29

Plot 2: Upper band edge

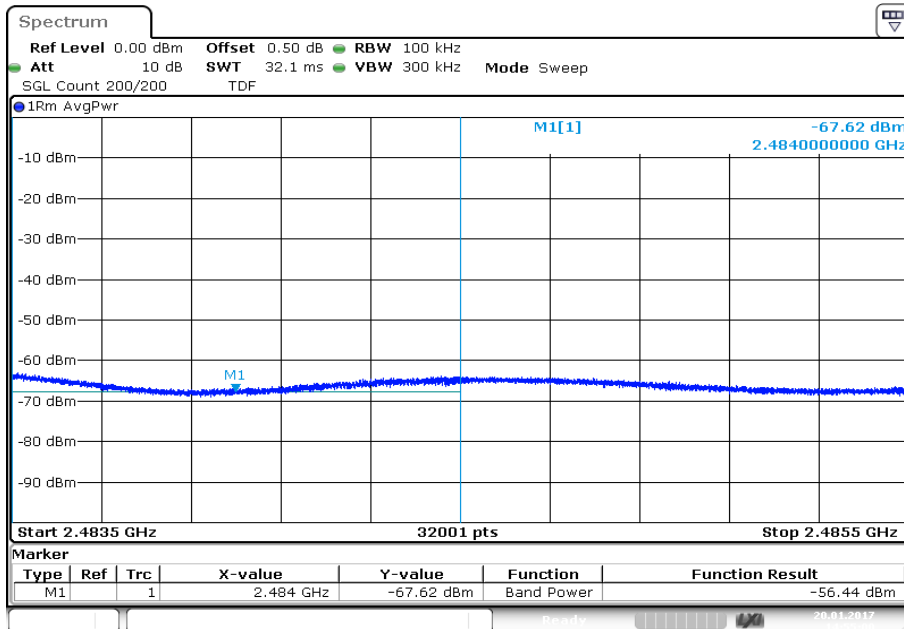

Date: 20.JAN.2017 14:55:00

Plots: OFDM / g – mode

Plot 1: Lower band edge

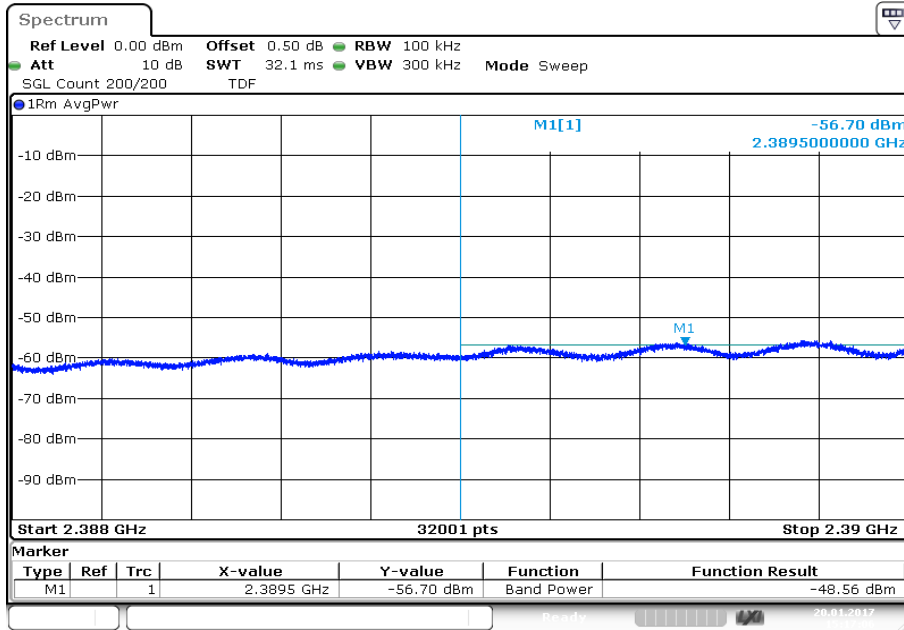

Date: 20.JAN.2017 15:17:06

Plot 2: Upper band edge

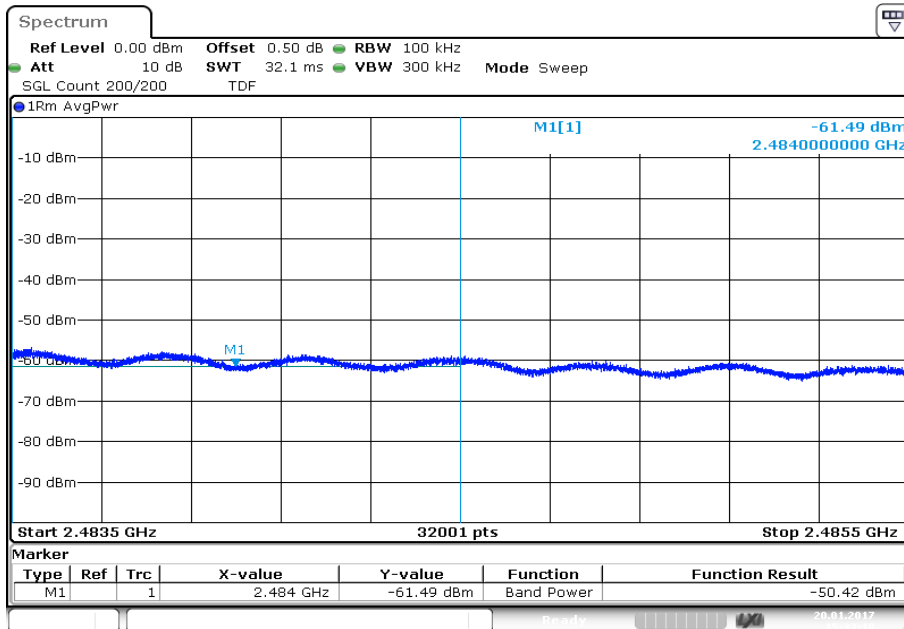

Date: 20.JAN.2017 15:33:18

Plots: OFDM / n HT20 – mode

Plot 1: Lower band edge

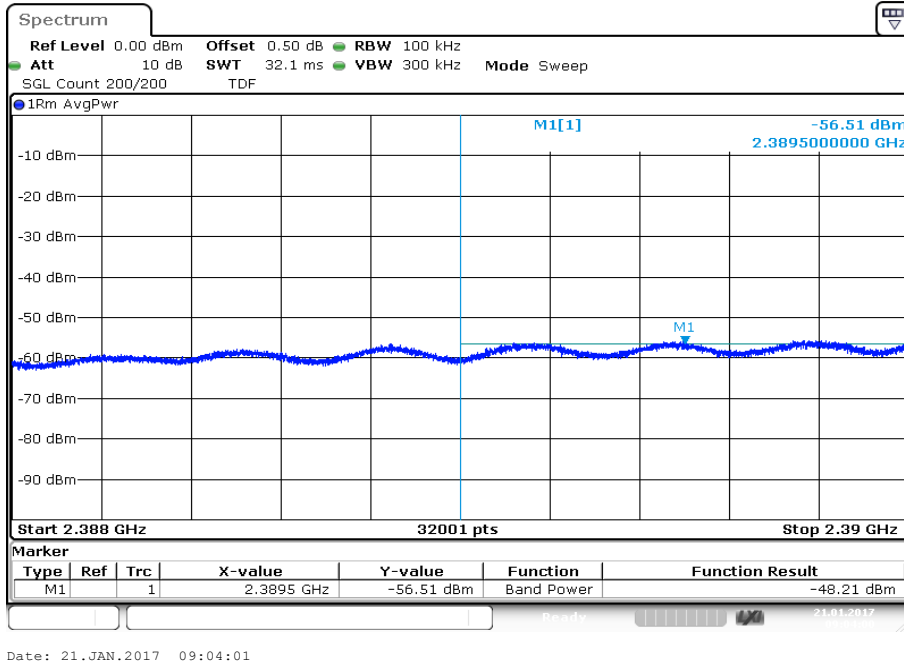

Plot 2: Upper band edge

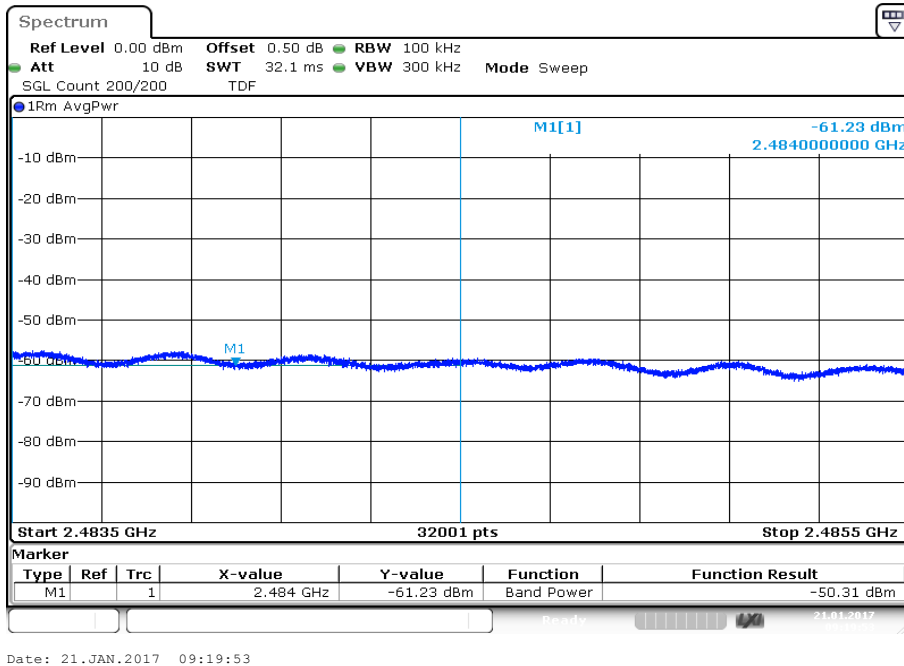

Plots: OFDM / n HT40 – mode

Plot 1: Lower band edge

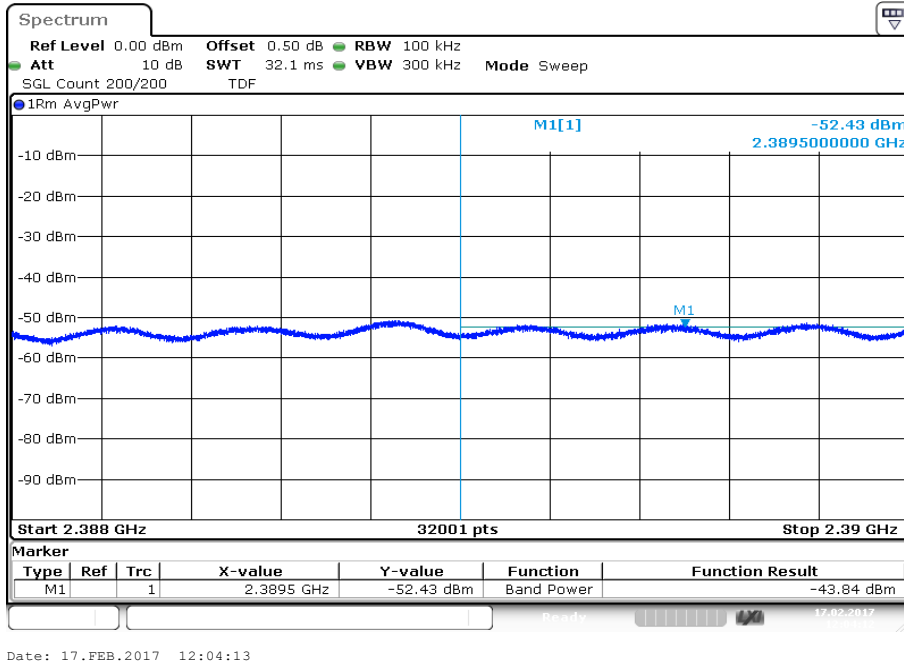

Plot 2: Upper band edge

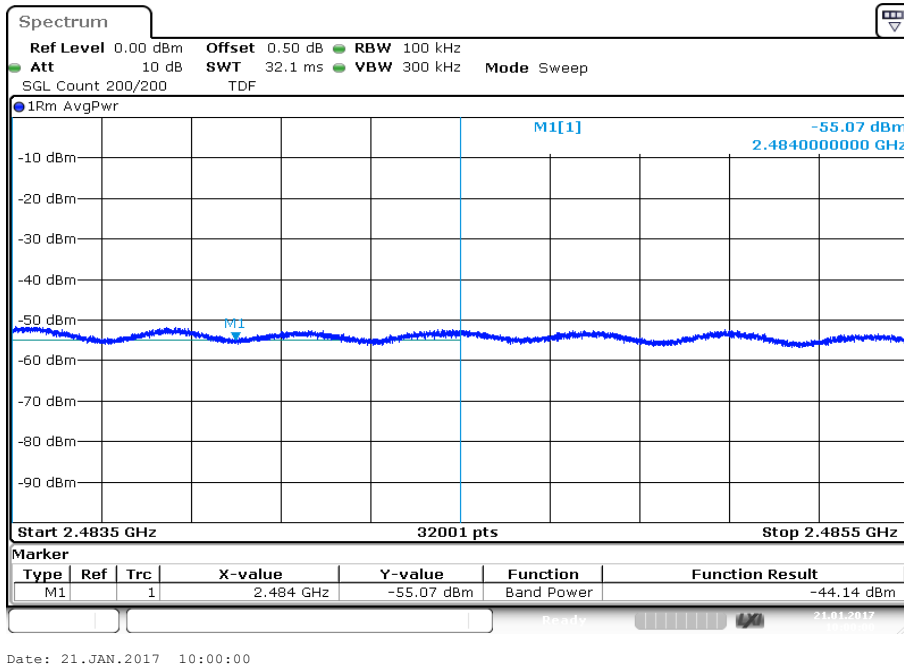

11.10 Spurious emissions conducted

Description:

Measurement of the conducted spurious emissions in transmit mode. The measurement is performed at channel 1, 6 and 11. The measurement is repeated for all modulations.

Measurement:

Measurement parameter	
Detector:	Peak
Sweep time:	Auto
Resolution bandwidth:	100 kHz
Video bandwidth:	500 kHz
Span:	9 kHz to 25 GHz
Trace mode:	Max Hold
Test setup:	See sub clause 6.5 – A
Measurement uncertainty	See sub clause 8

Limits:

FCC	IC
In any 100 kHz bandwidth outside the frequency band in which the spread spectrum or digitally modulated intentional radiator is operating, the radio frequency power that is produced by the intentional radiator shall be at least 30 dB below that in the 100 kHz bandwidth within the band that contains the highest level of the desired power, based on either an RF conducted or a radiated measurement. Attenuation below the general limits specified in Section 15.209(a) is not required	

Results: DSSS / b – mode

TX Spurious Emissions Conducted					
DSSS / b – mode					
f [MHz]		amplitude of emission [dBm]	limit max. allowed emission power	actual attenuation below frequency of operation [dB]	results
2412		2.25	30 dBm		Operating frequency
No peaks detected.			-20 dBc (peak) -30 dBc (average)		compliant
2437		3.41	30 dBm		Operating frequency
No peaks detected.			-20 dBc (peak) -30 dBc (average)		compliant
2462		2.75	30 dBm		Operating frequency
No peaks detected.			-20 dBc (peak) -30 dBc (average)		compliant

Results: OFDM / g – mode

TX Spurious Emissions Conducted					
OFDM / g – mode					
f [MHz]		amplitude of emission [dBm]	limit max. allowed emission power	actual attenuation below frequency of operation [dB]	results
2412		-6.82	30 dBm		Operating frequency
No peaks detected.			-20 dBc (peak) -30 dBc (average)		compliant
2437		-3.94	30 dBm		Operating frequency
No peaks detected.			-20 dBc (peak) -30 dBc (average)		compliant
2462		-6.09	30 dBm		Operating frequency
No peaks detected.			-20 dBc (peak) -30 dBc (average)		compliant

Results: OFDM / n HT20 – mode

TX Spurious Emissions Conducted					
OFDM / n HT20 – mode					
f [MHz]		amplitude of emission [dBm]	limit max. allowed emission power	actual attenuation below frequency of operation [dB]	results
2412		-7.76	30 dBm		Operating frequency
No peaks detected.			-20 dBc (peak) -30 dBc (average)		compliant
2437		-4.87	30 dBm		Operating frequency
No peaks detected.			-20 dBc (peak) -30 dBc (average)		compliant
2462		-7.45	30 dBm		Operating frequency
No peaks detected.			-20 dBc (peak) -30 dBc (average)		compliant

Results: OFDM / n HT40 – mode

TX Spurious Emissions Conducted					
OFDM / n HT40 – mode					
f [MHz]		amplitude of emission [dBm]	limit max. allowed emission power	actual attenuation below frequency of operation [dB]	results
2422		-10.59	30 dBm		Operating frequency
No peaks detected.			-20 dBc (peak) -30 dBc (average)		compliant
2437		-7.67	30 dBm		Operating frequency
No peaks detected.			-20 dBc (peak) -30 dBc (average)		compliant
2452		-10.33	30 dBm		Operating frequency
No peaks detected.			-20 dBc (peak) -30 dBc (average)		compliant

Plots: DSSS / b – mode

Plot 1: Lowest channel, up to 25 GHz

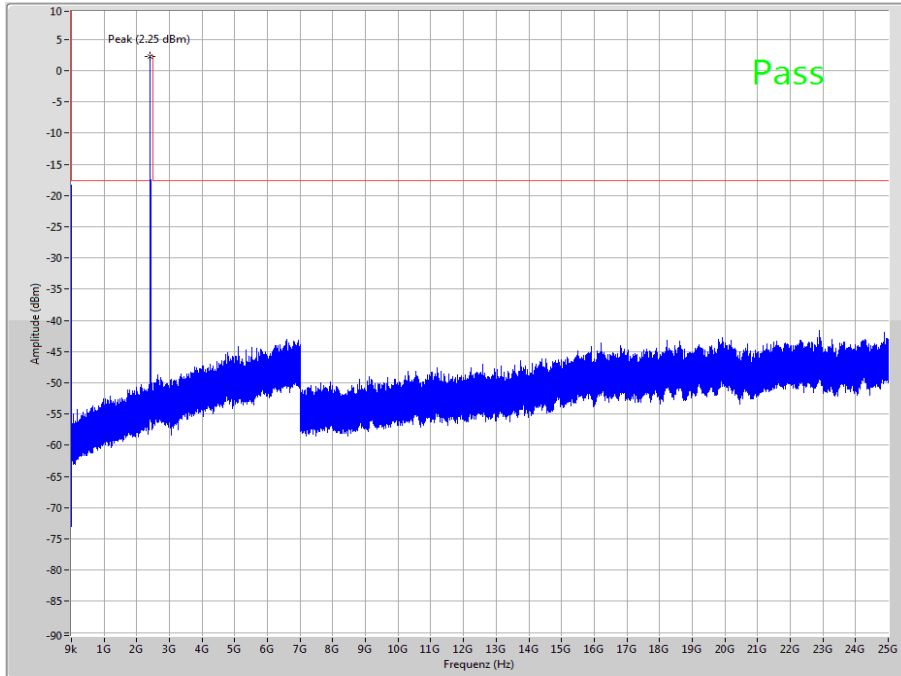

The peak at the beginning of the plot is the LO from the SA.

Plot 2: Lowest channel, zoomed carrier

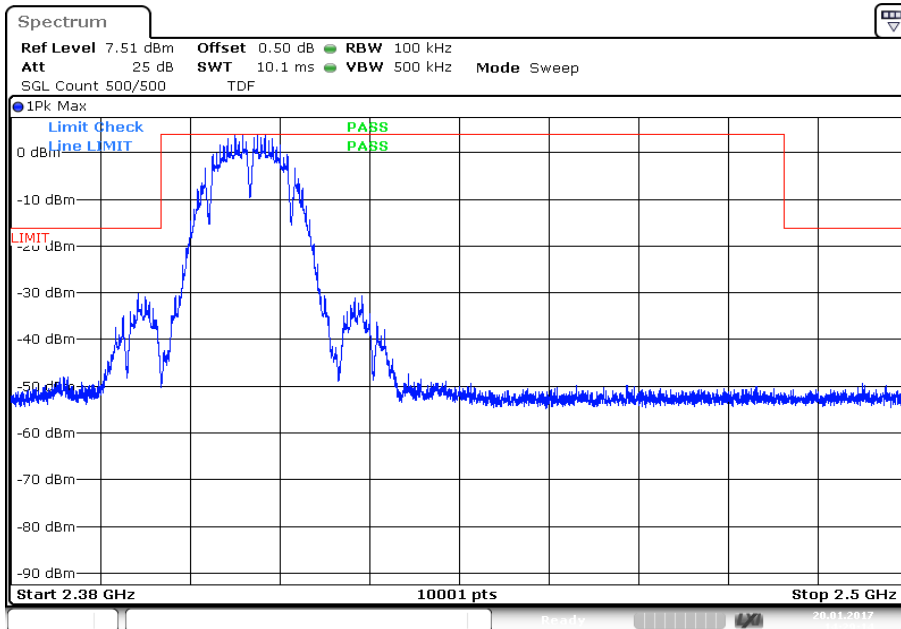

Date: 20.JAN.2017 14:29:14

Plot 3: Middle channel, up to 25 GHz

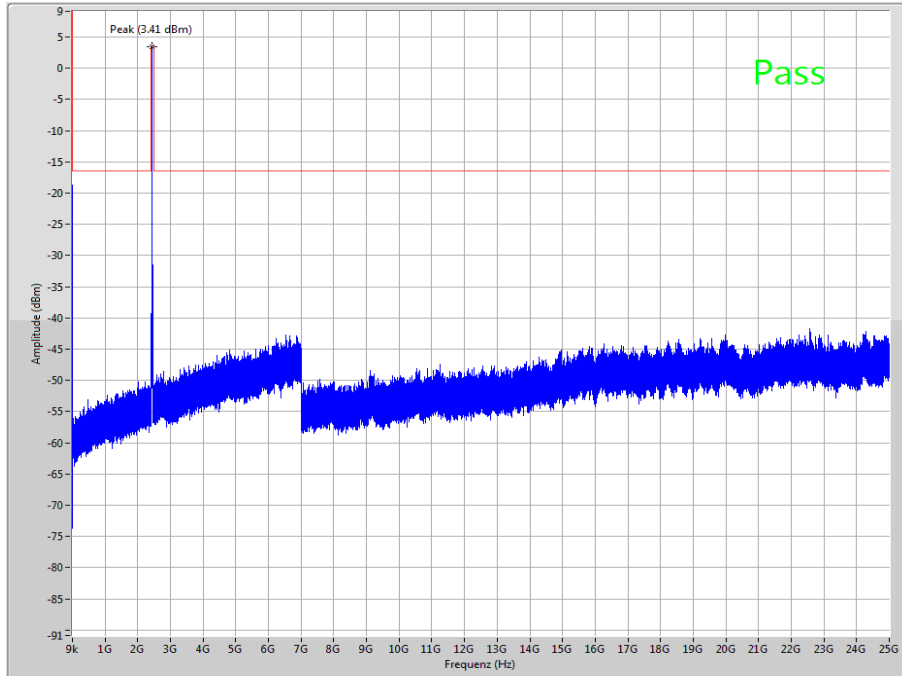

The peak at the beginning of the plot is the LO from the SA.

Plot 4: Middle channel, zoomed carrier

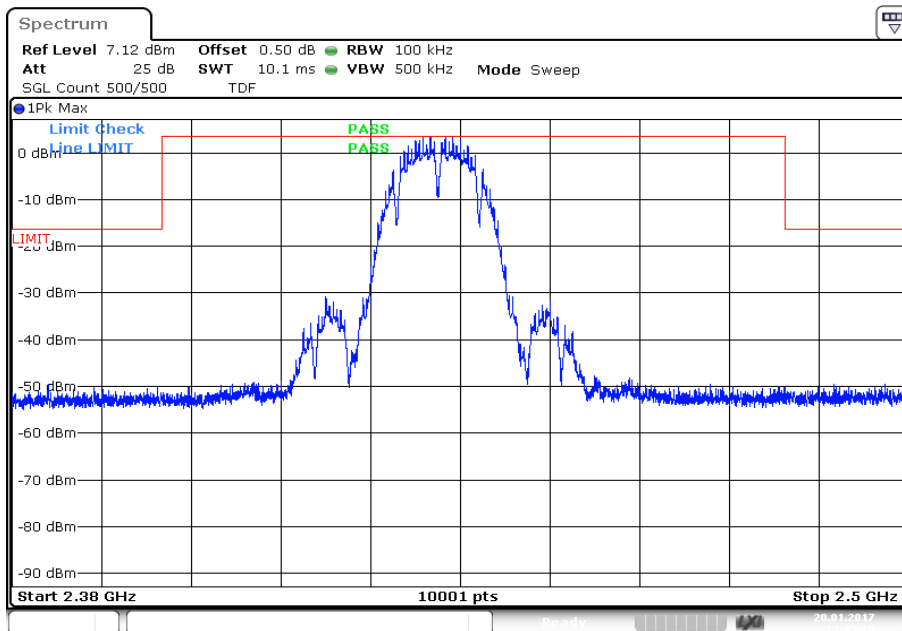

Date: 20.JAN.2017 14:45:16

Plot 5: Highest channel, up to 25 GHz

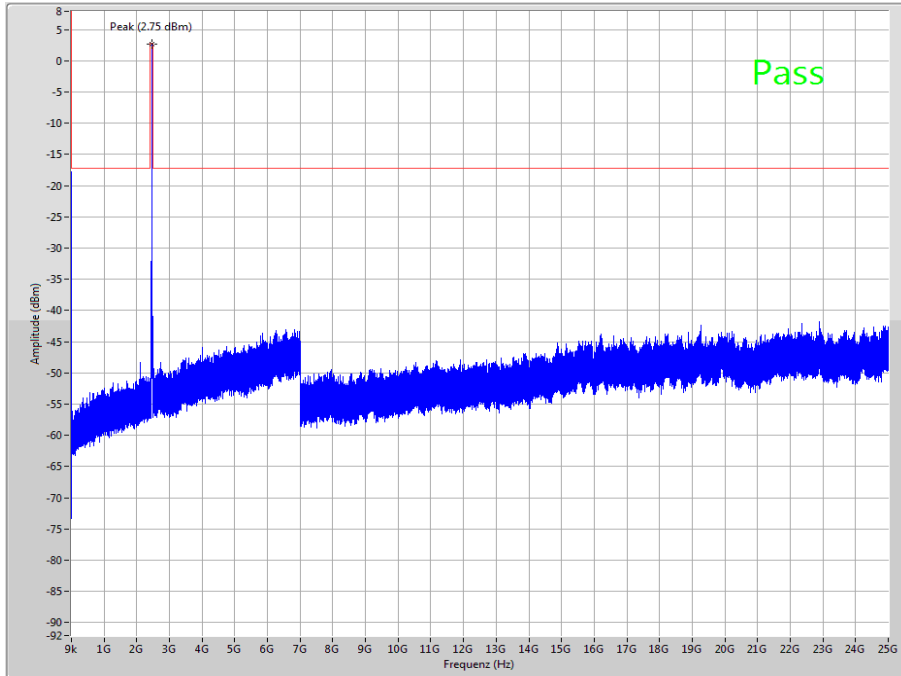

The peak at the beginning of the plot is the LO from the SA.

Plot 6: Highest channel, zoomed carrier

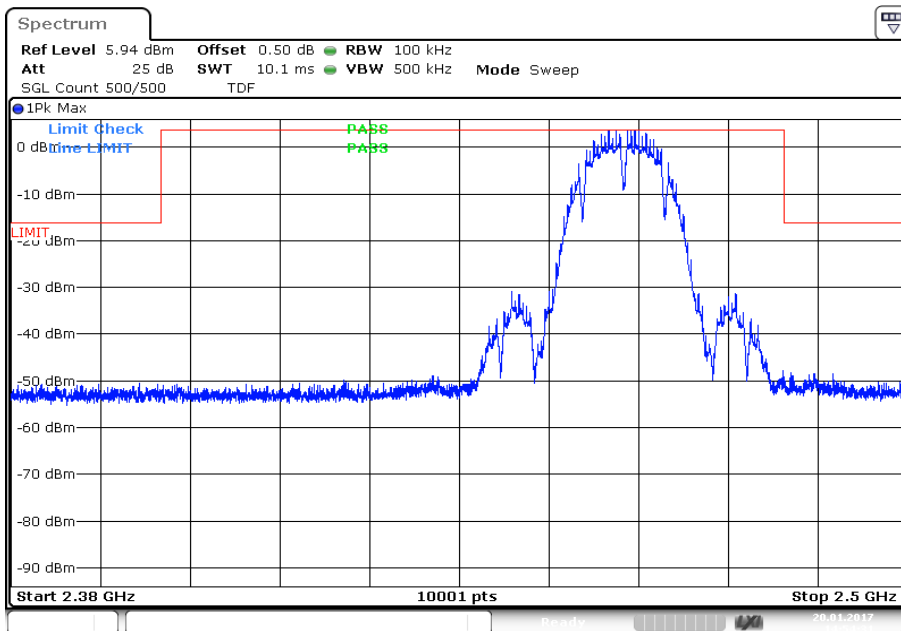

Date: 20.JAN.2017 14:54:31

Plots: OFDM / g – mode

Plot 1: Lowest channel, up to 25 GHz

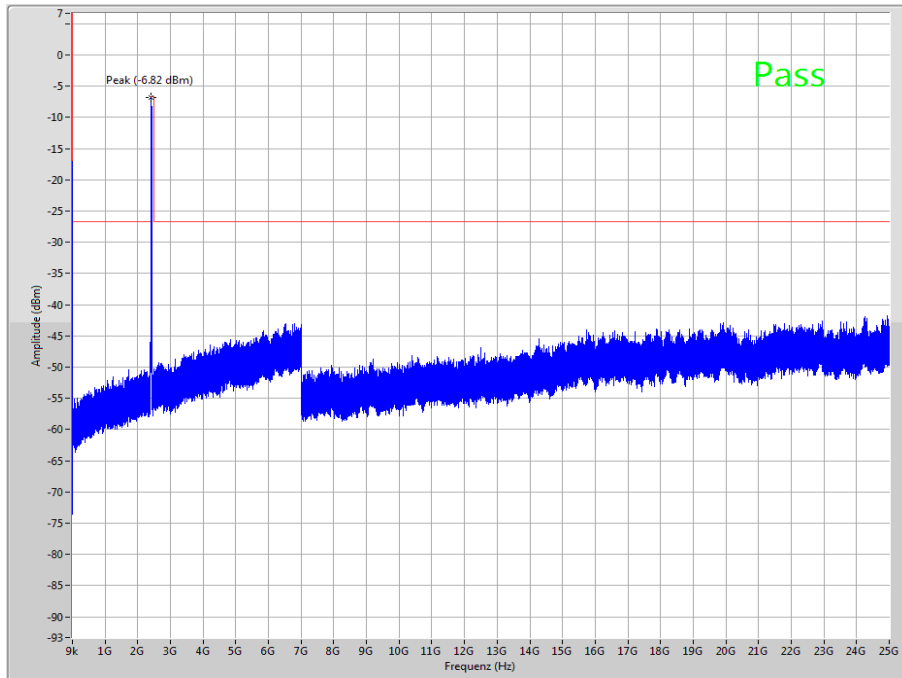

The peak at the beginning of the plot is the LO from the SA.

Plot 2: Lowest channel, zoomed carrier

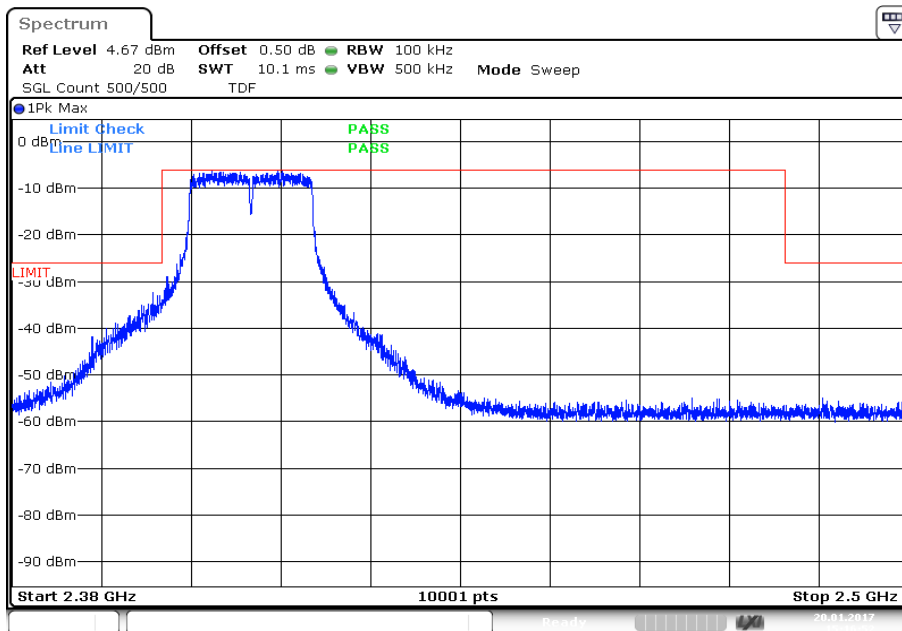

Date: 20.JAN.2017 15:16:52

Plot 3: Middle channel, up to 25 GHz

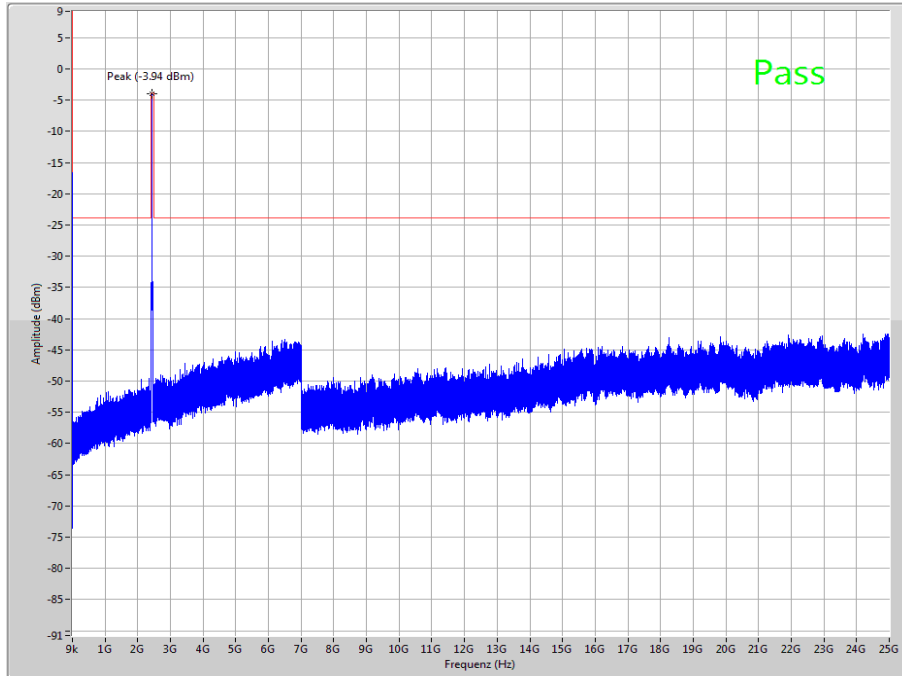

The peak at the beginning of the plot is the LO from the SA.

Plot 4: Middle channel, zoomed carrier

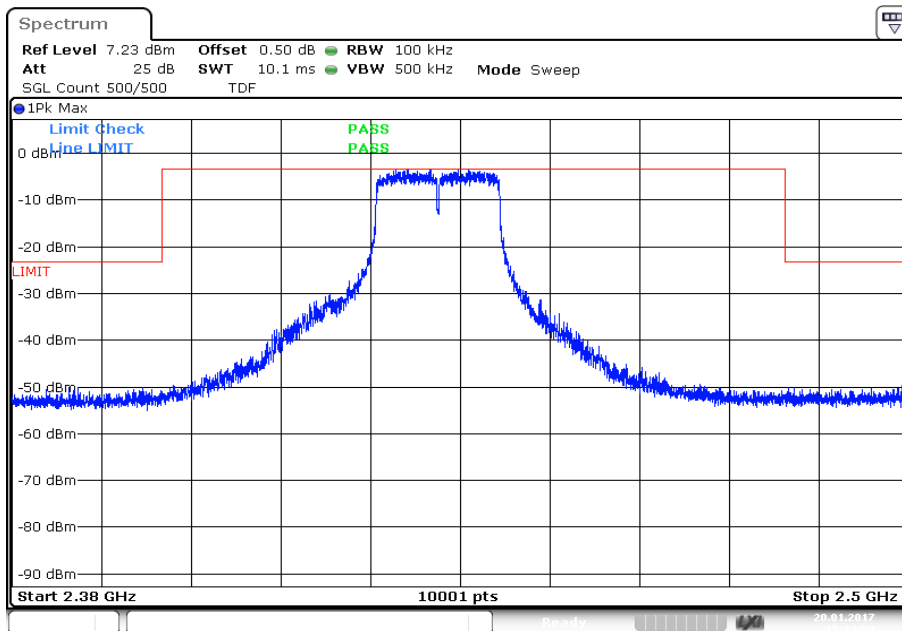

Date: 20.JAN.2017 15:24:50

Plot 5: Highest channel, up to 25 GHz

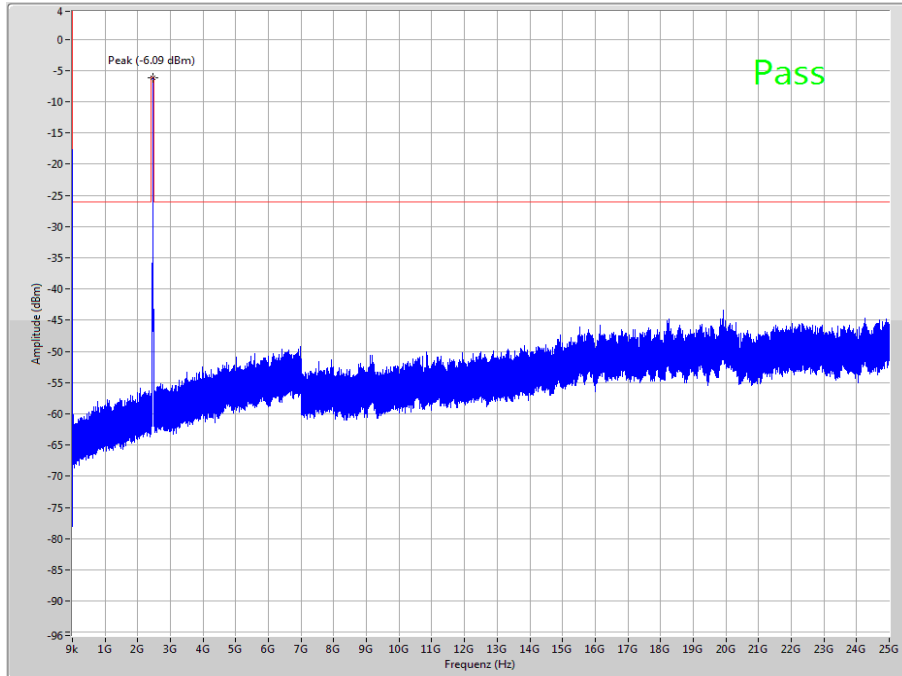

The peak at the beginning of the plot is the LO from the SA.

Plot 6: Highest channel, zoomed carrier

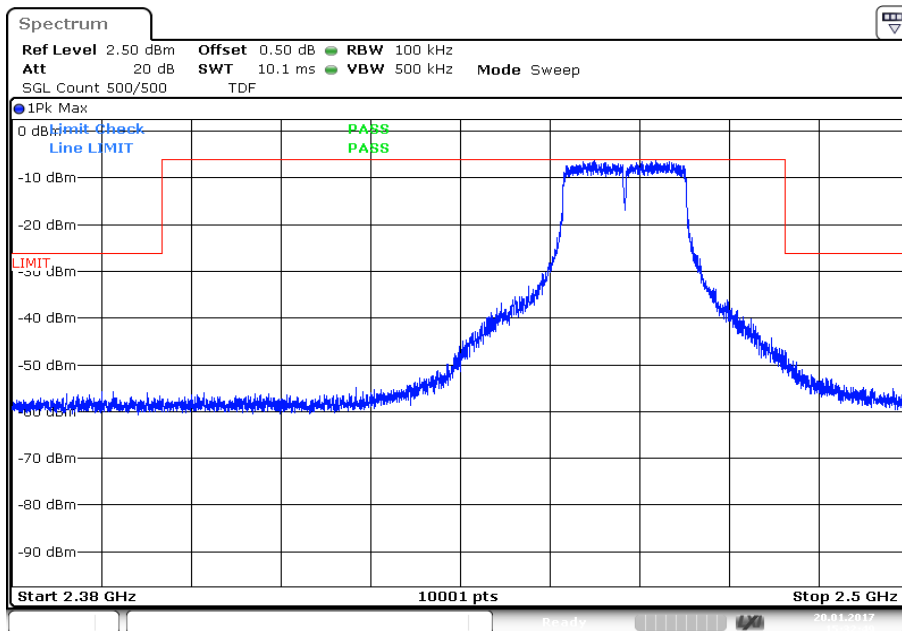

Plots: OFDM / n HT 20 – mode

Plot 1: Lowest channel, up to 25 GHz

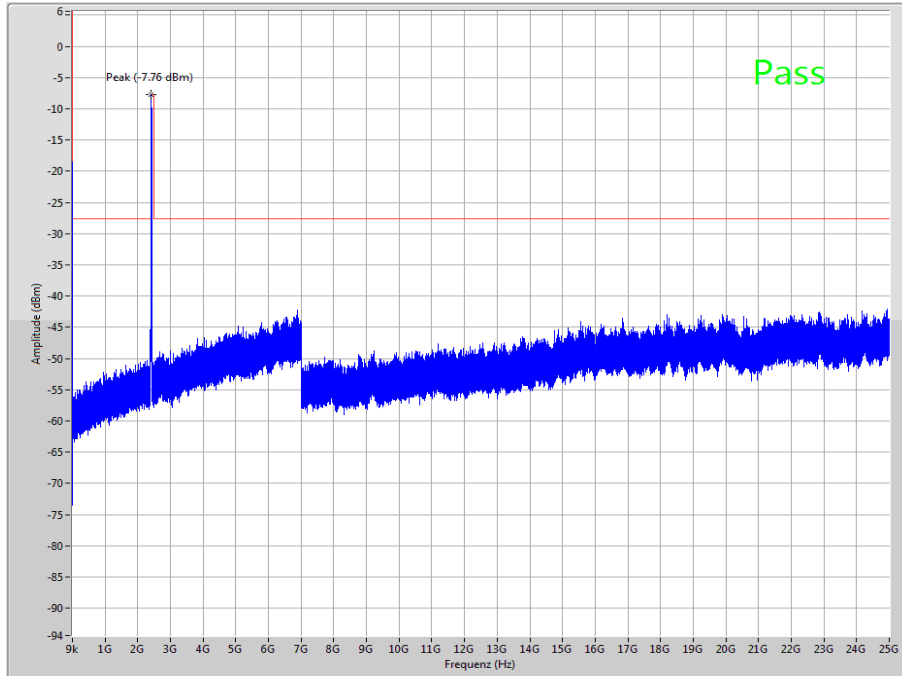

The peak at the beginning of the plot is the LO from the SA.

Plot 2: Lowest channel, zoomed carrier

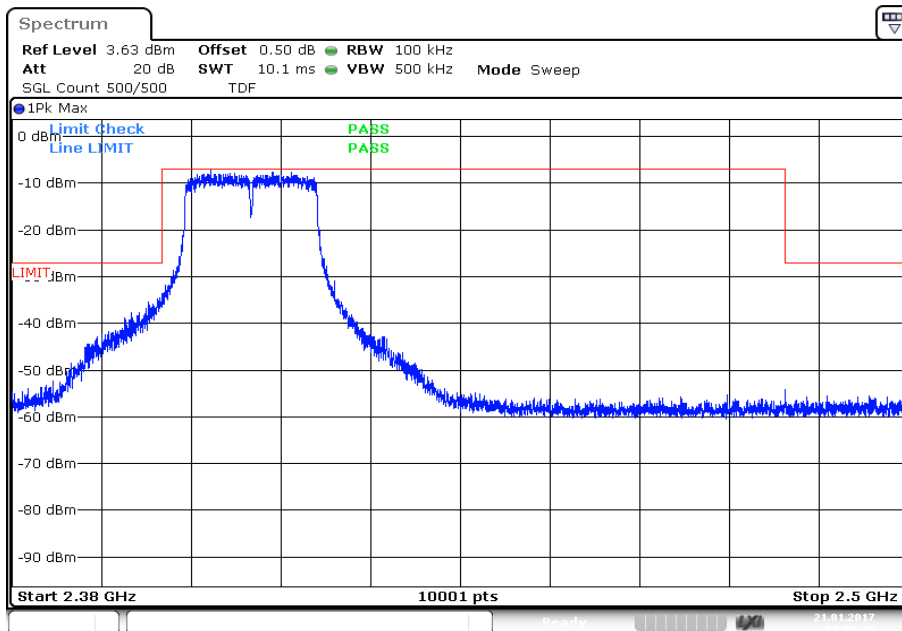

Date: 21.JAN.2017 09:03:46

Plot 3: Middle channel, up to 25 GHz

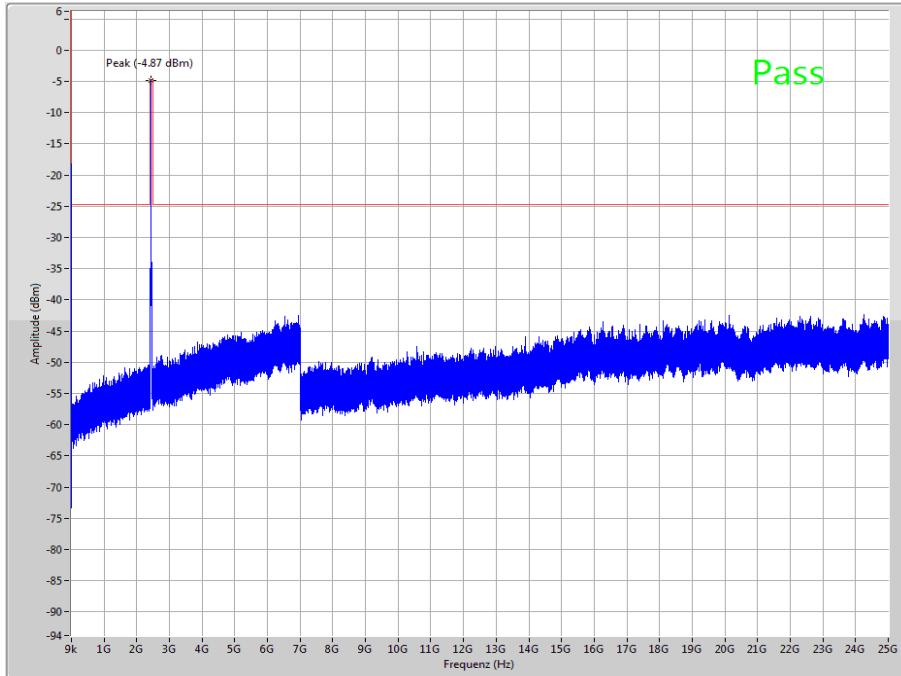

The peak at the beginning of the plot is the LO from the SA.

Plot 4: Middle channel, zoomed carrier

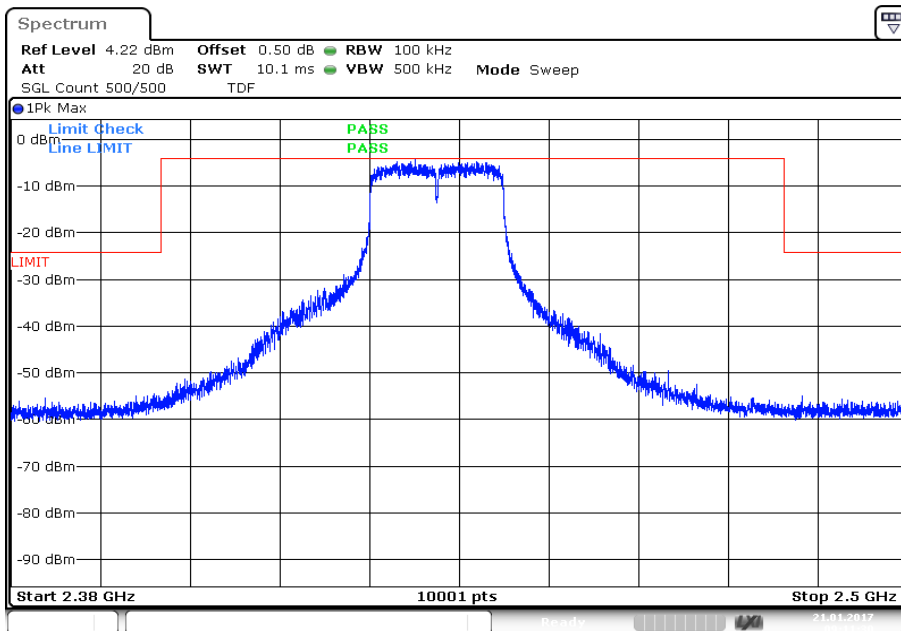

Date: 21.JAN.2017 09:11:30

Plot 5: Highest channel, up to 25 GHz

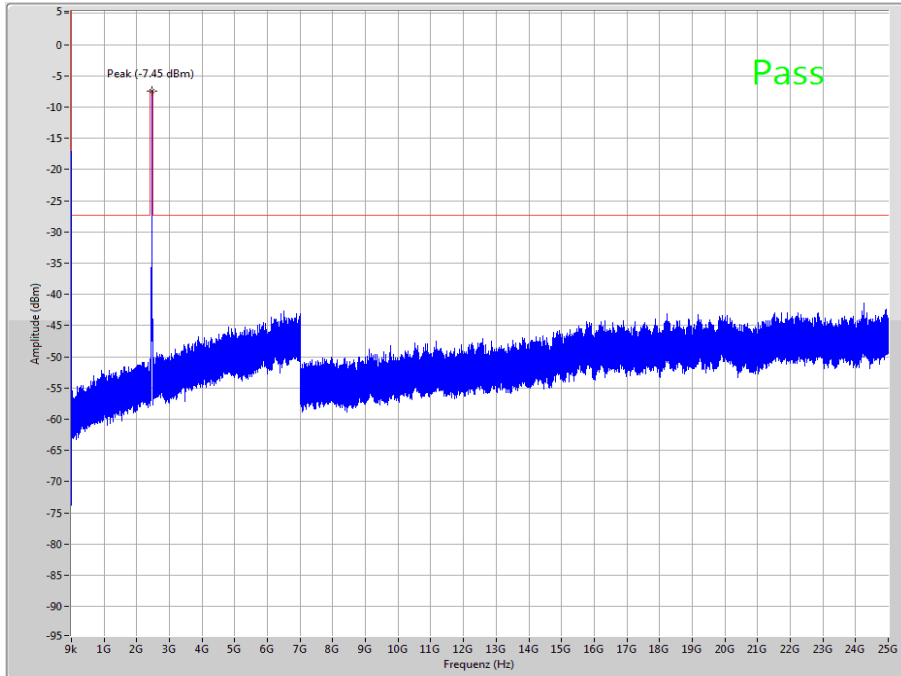

The peak at the beginning of the plot is the LO from the SA.

Plot 6: Highest channel, zoomed carrier

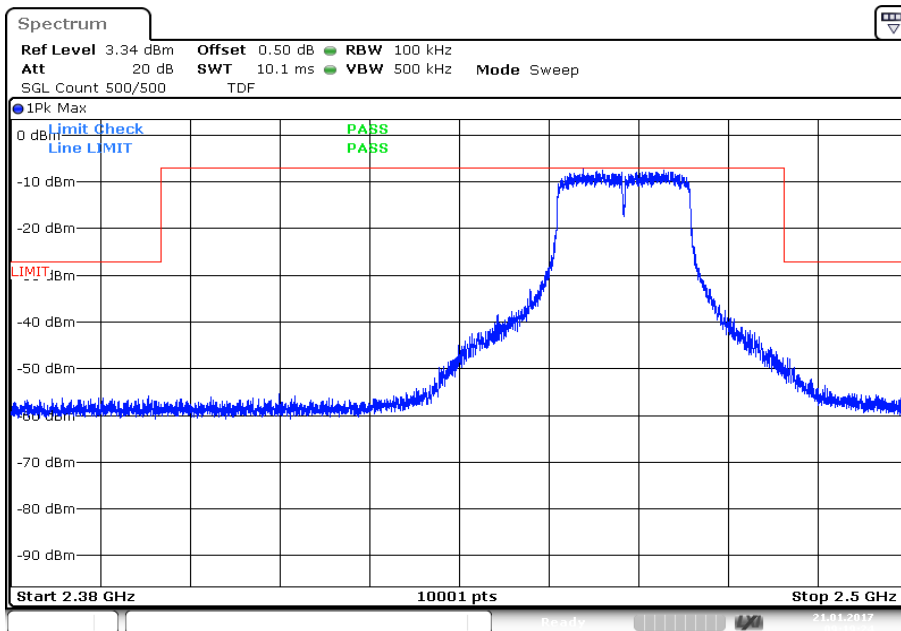

Date: 21.JAN.2017 09:19:24

Plots: OFDM / n HT 40 – mode

Plot 1: Lowest channel, up to 25 GHz

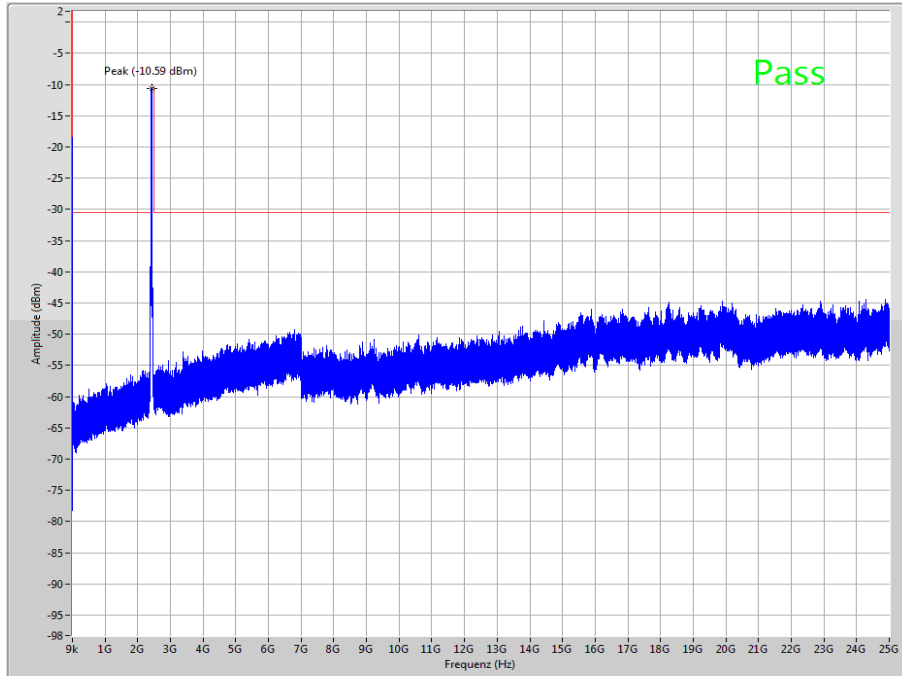

The peak at the beginning of the plot is the LO from the SA.

Plot 2: Lowest channel, zoomed carrier

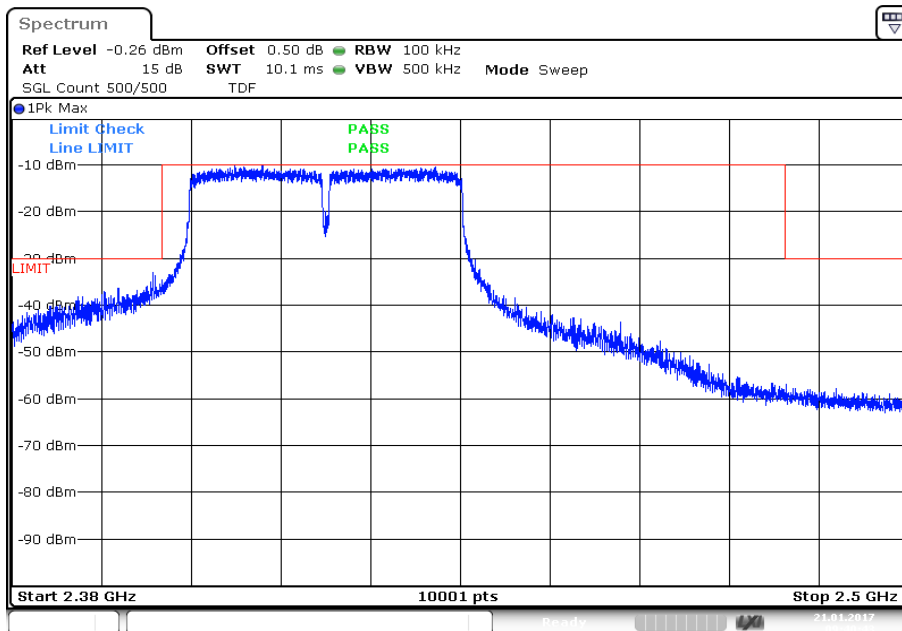

Date: 21.JAN.2017 09:40:42

Plot 3: Middle channel, up to 25 GHz

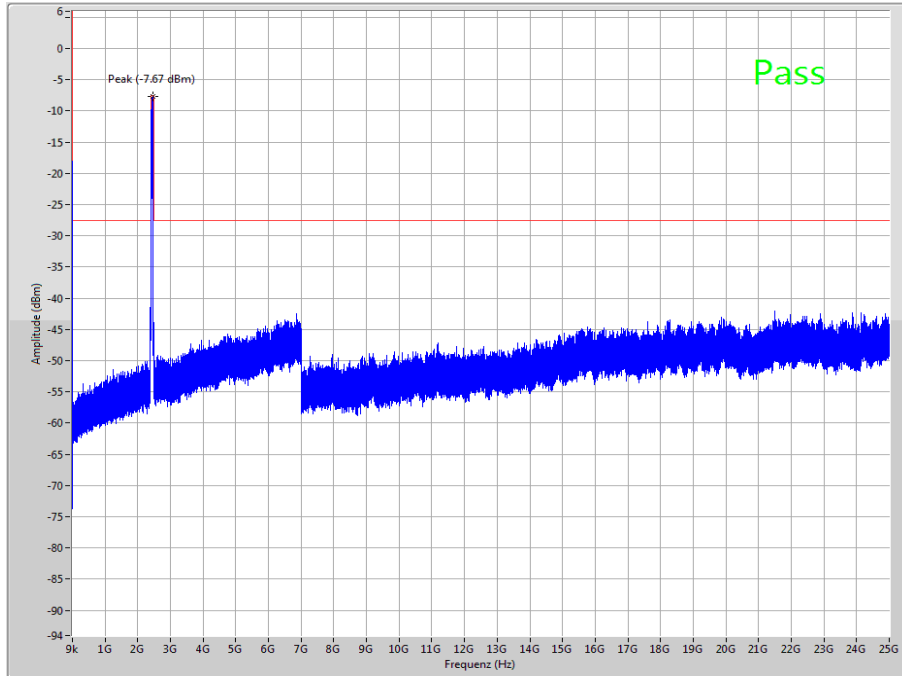

The peak at the beginning of the plot is the LO from the SA.

Plot 4: Middle channel, zoomed carrier

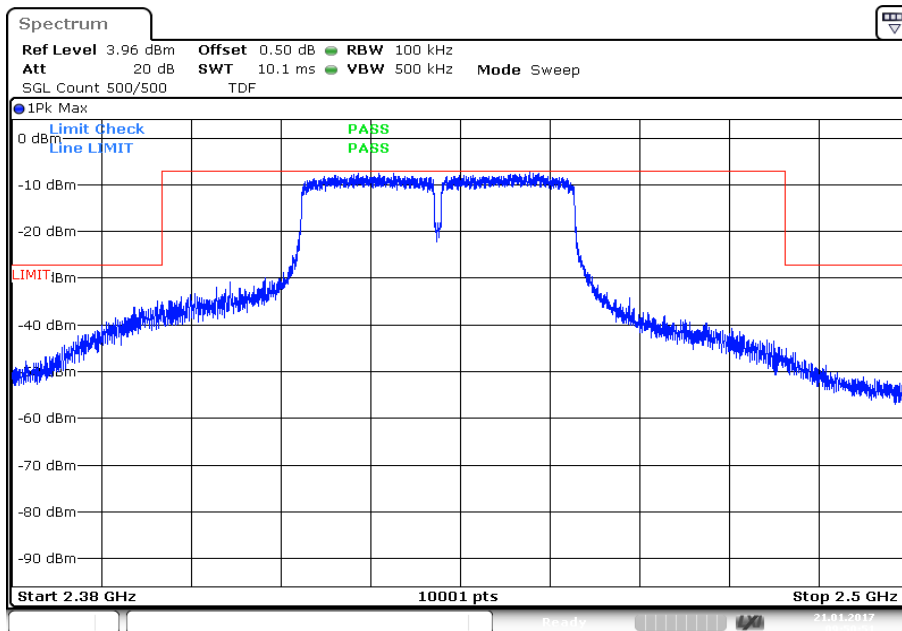

Date: 21.JAN.2017 09:50:51

Plot 5: Highest channel, up to 25 GHz

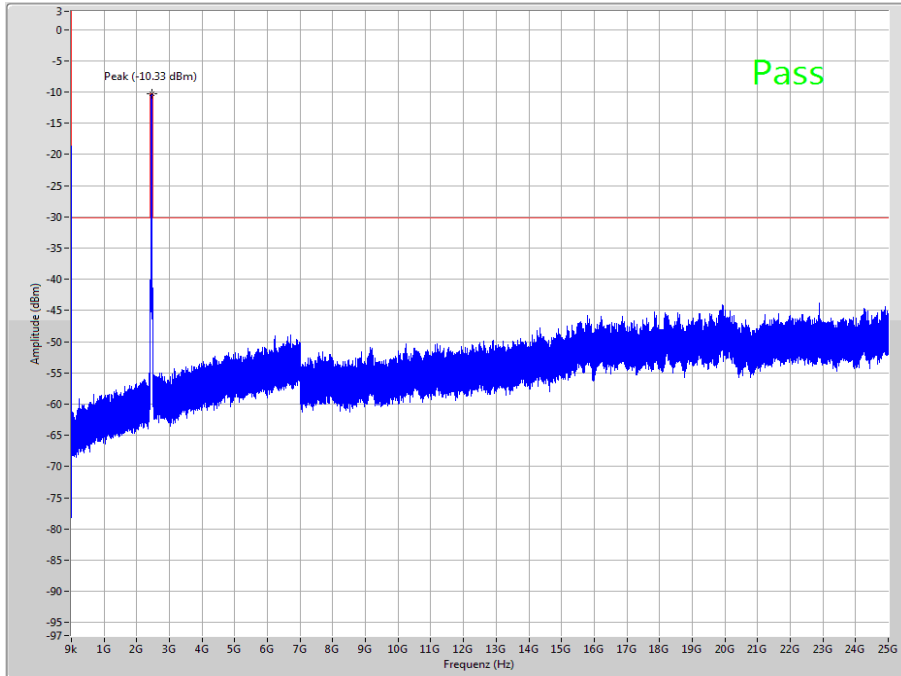

The peak at the beginning of the plot is the LO from the SA.

Plot 6: Highest channel, zoomed carrier

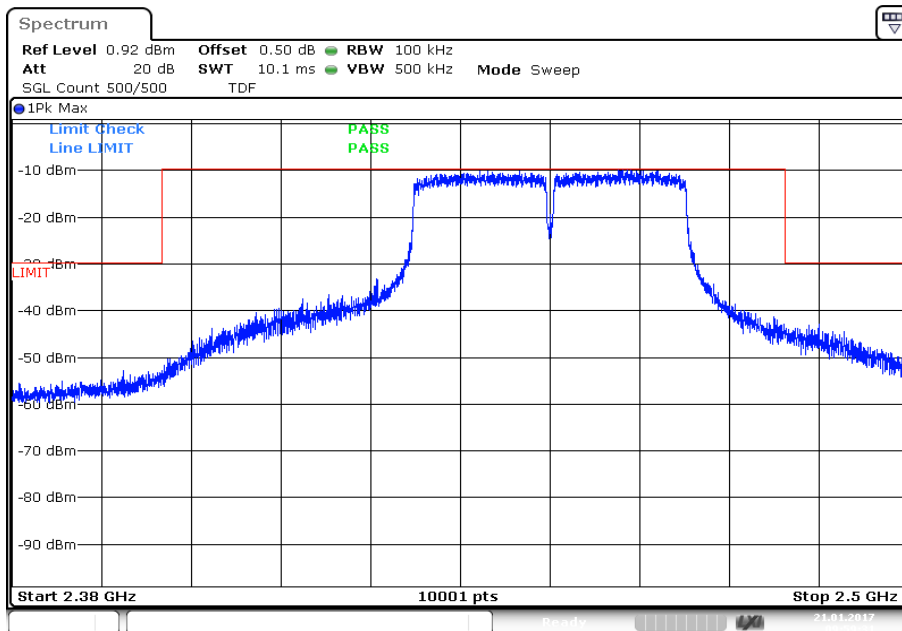

Date: 21.JAN.2017 09:59:31

11.11 Spurious emissions radiated below 30 MHz

Description:

Measurement of the radiated spurious emissions in transmit mode below 30 MHz. The EUT is set to channel 6. This measurement is representative for all channels and modes. If peaks are found channel 1 and channel 11 will be measured too. The measurement is performed with the data rate producing the highest output power. The limits are recalculated to a measurement distance of 3 m with 40 dB/decade according CFR Part 2.

Measurement:

Measurement parameter	
Detector:	Peak / Quasi Peak
Sweep time:	Auto
Resolution bandwidth:	F < 150 kHz: 200 Hz F > 150 kHz: 9 kHz
Video bandwidth:	F < 150 kHz: 1 kHz F > 150 kHz: 100 kHz
Span:	9 kHz to 30 MHz
Trace mode:	Max Hold
Measured modulation	<input checked="" type="checkbox"/> DSSS b – mode <input checked="" type="checkbox"/> OFDM g – mode <input type="checkbox"/> OFDM n HT20 – mode <input checked="" type="checkbox"/> OFDM n HT40 – mode
Test setup:	See sub clause 6.2 – A
Measurement uncertainty	See sub clause 8

Limits:

FCC		IC
Frequency [MHz]	Field Strength [dBµV/m]	Measurement distance [m]
0.009 – 0.490	2400/F(kHz)	300
0.490 – 1.705	24000/F(kHz)	30
1.705 – 30.0	30	30

Results: (External antennas)

For the results of the spurious emission tests radiated of all external antennas see “Appendix_to_1-2846/16-02-04-B”

Results: (Internal antenna)

TX Spurious Emissions Radiated < 30 MHz [dBµV/m]		
F [MHz]	Detector	Level [dBµV/m]
All detected peaks are more than 20 dB below the limit.		

Plots: DSSS

Plot 1: 9 kHz to 30 MHz, low channel

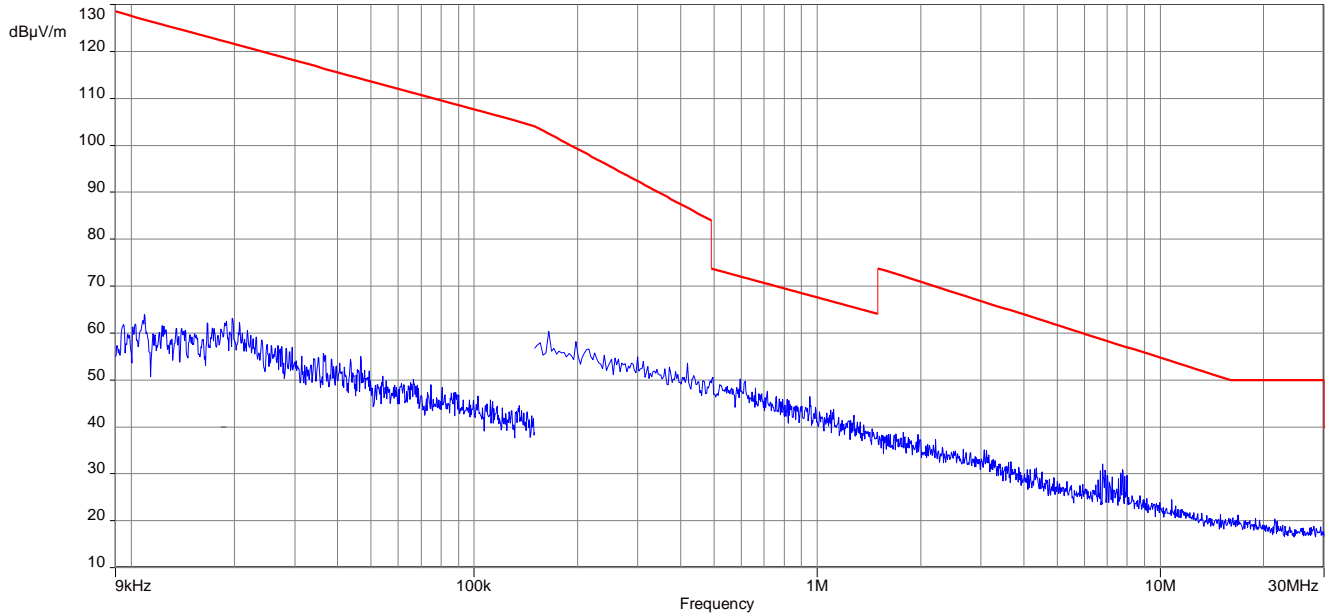

Plot 2: 9 kHz to 30 MHz, mid channel

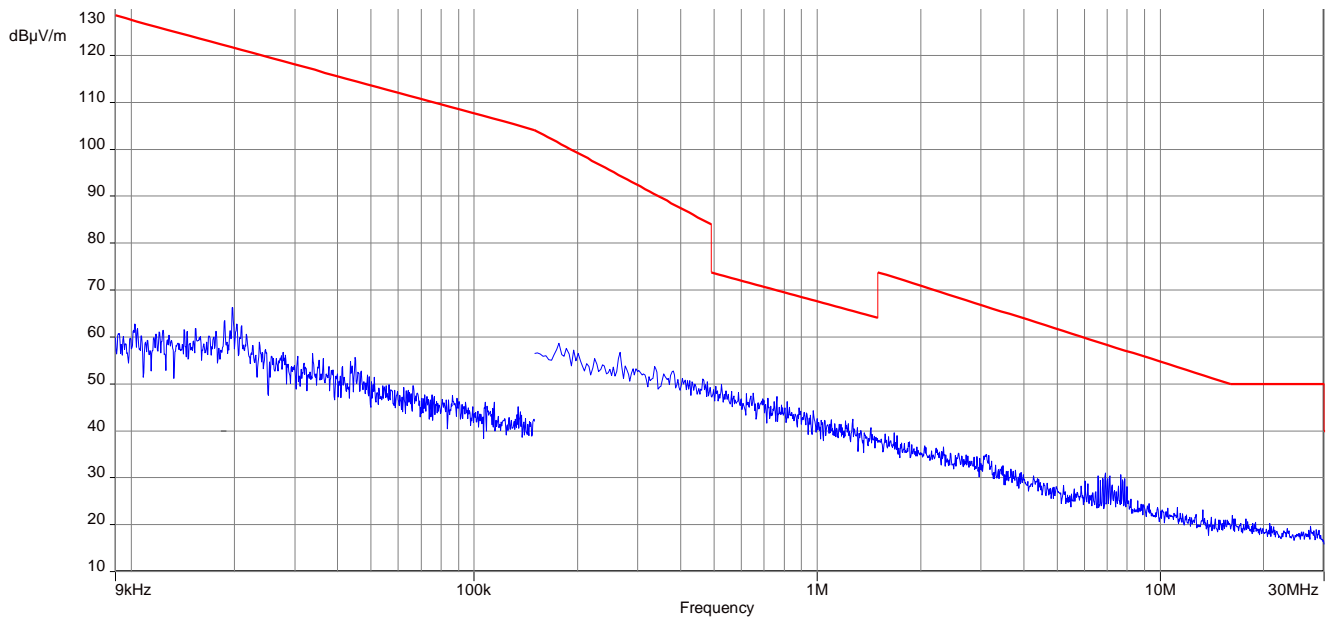

Plot 3: 9 kHz to 30 MHz, high channel

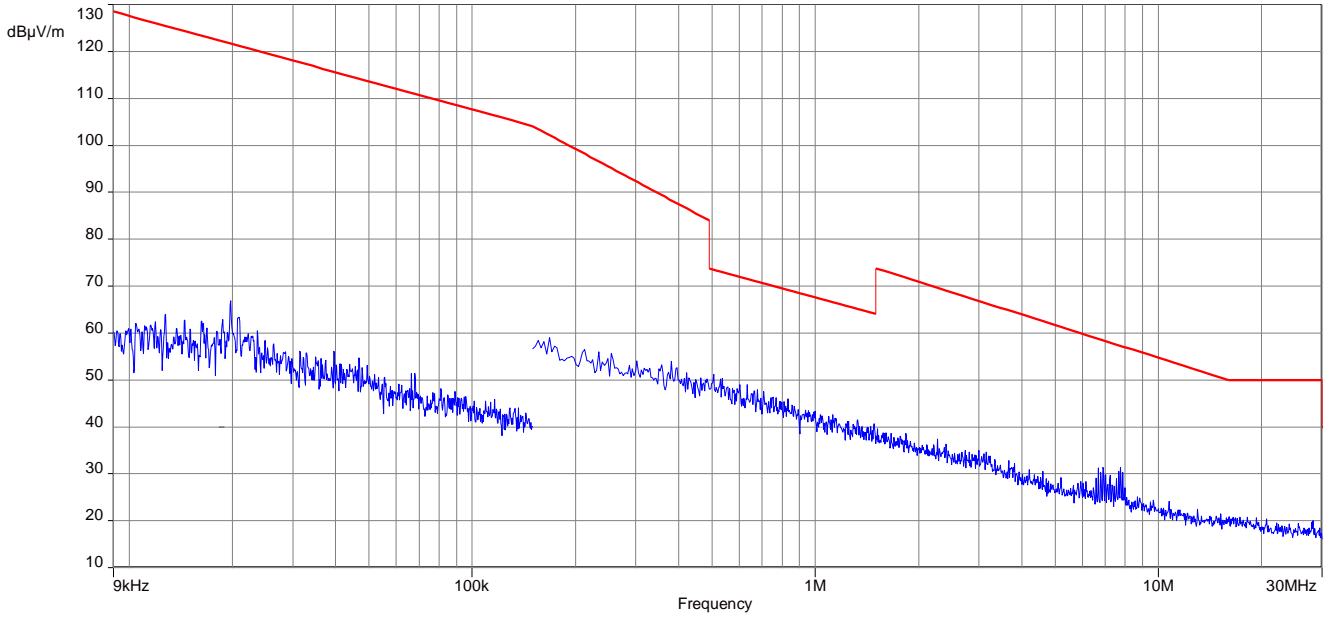

Plots: OFDM (20 MHz bandwidth)

Plot 1: 9 kHz to 30 MHz, low channel

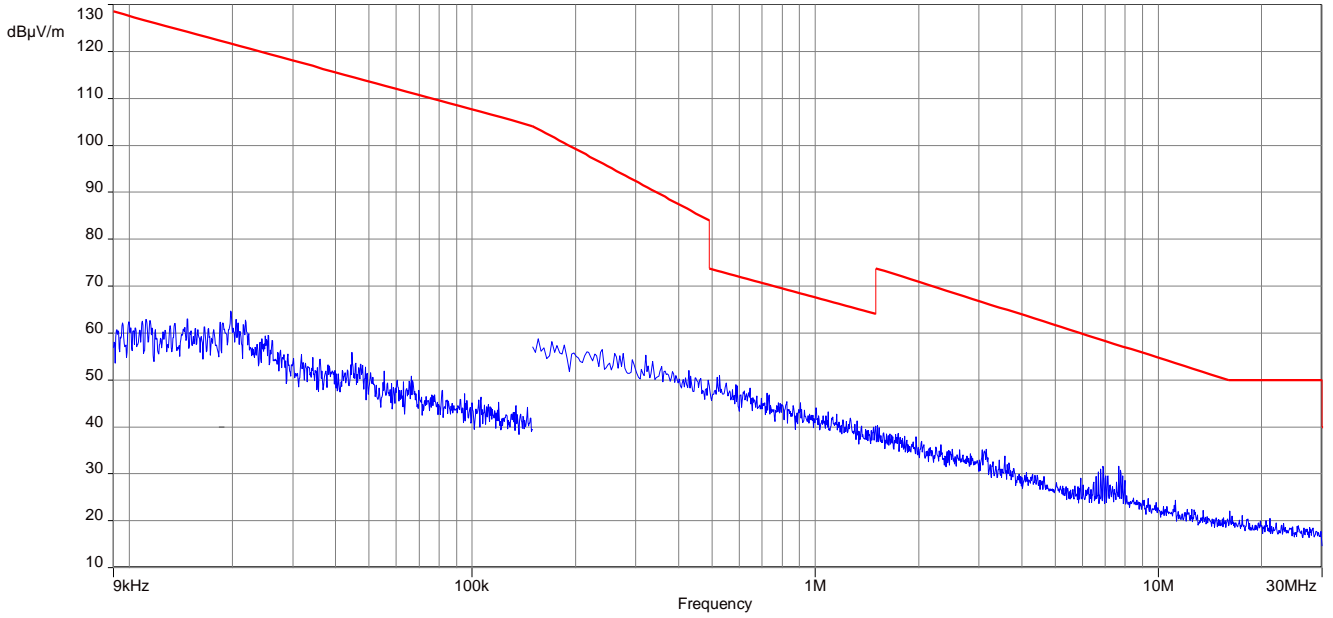

Plot 2: 9 kHz to 30 MHz, mid channel

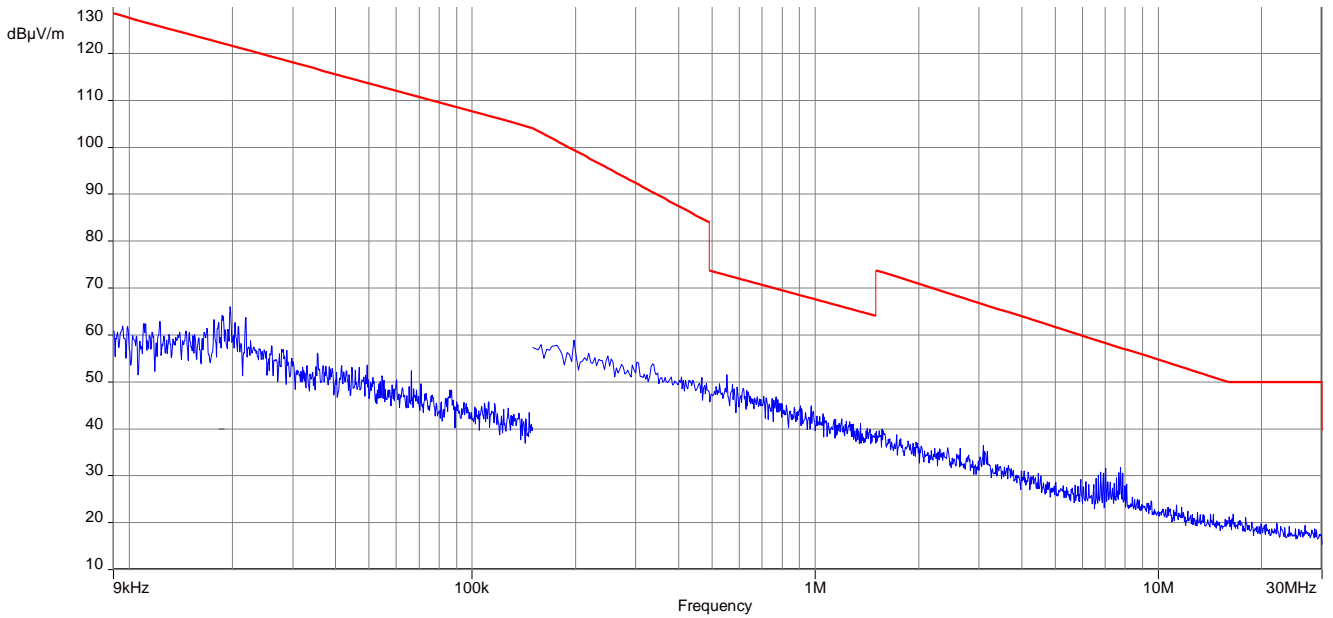

Plot 3: 9 kHz to 30 MHz, high channel

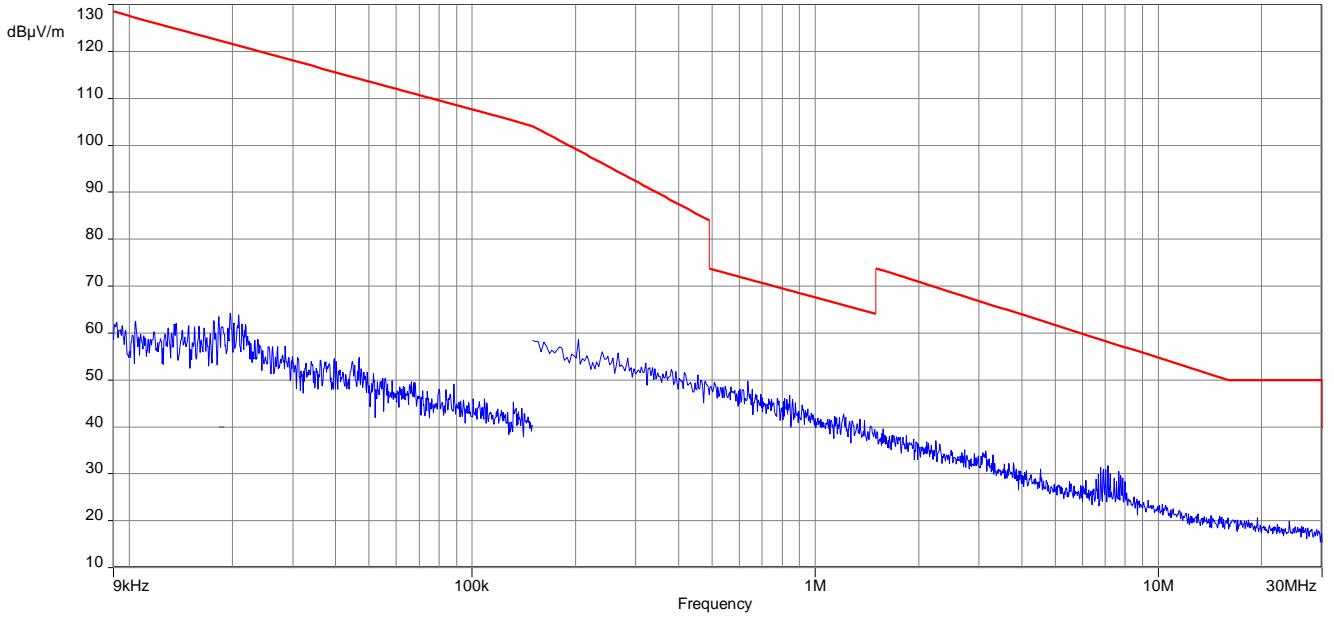

Plots: OFDM (40 MHz bandwidth)

Plot 1: 9 kHz to 30 MHz, low channel

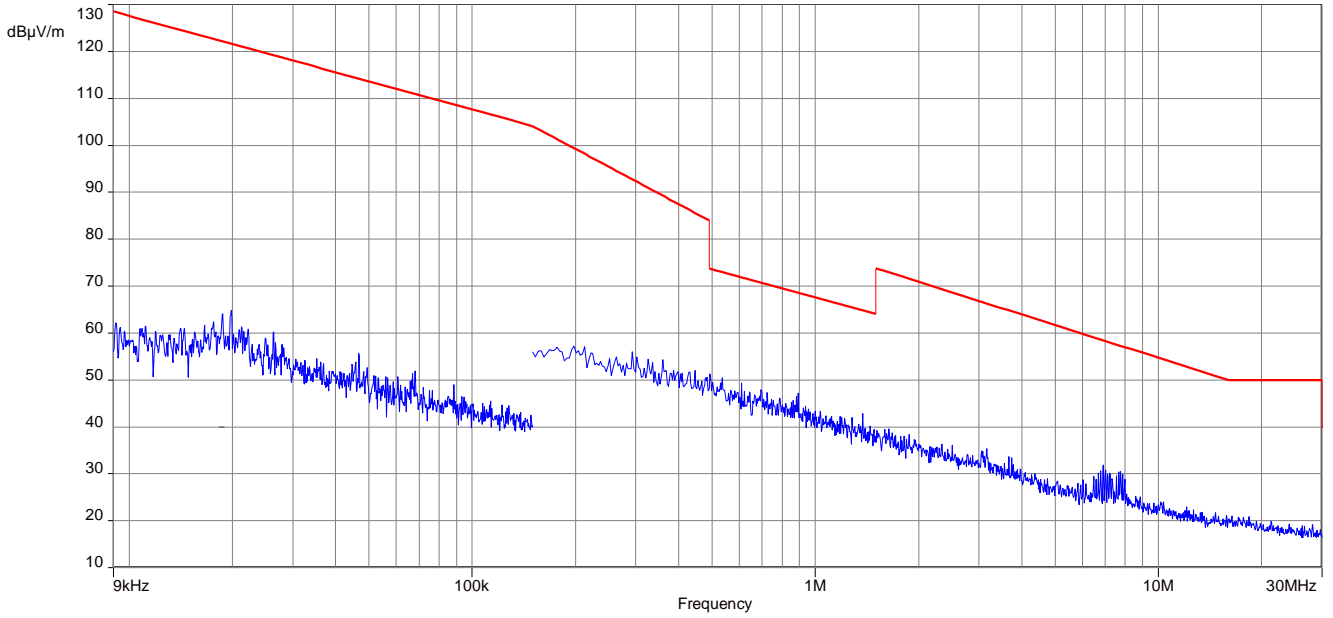

Plot 2: 9 kHz to 30 MHz, mid channel

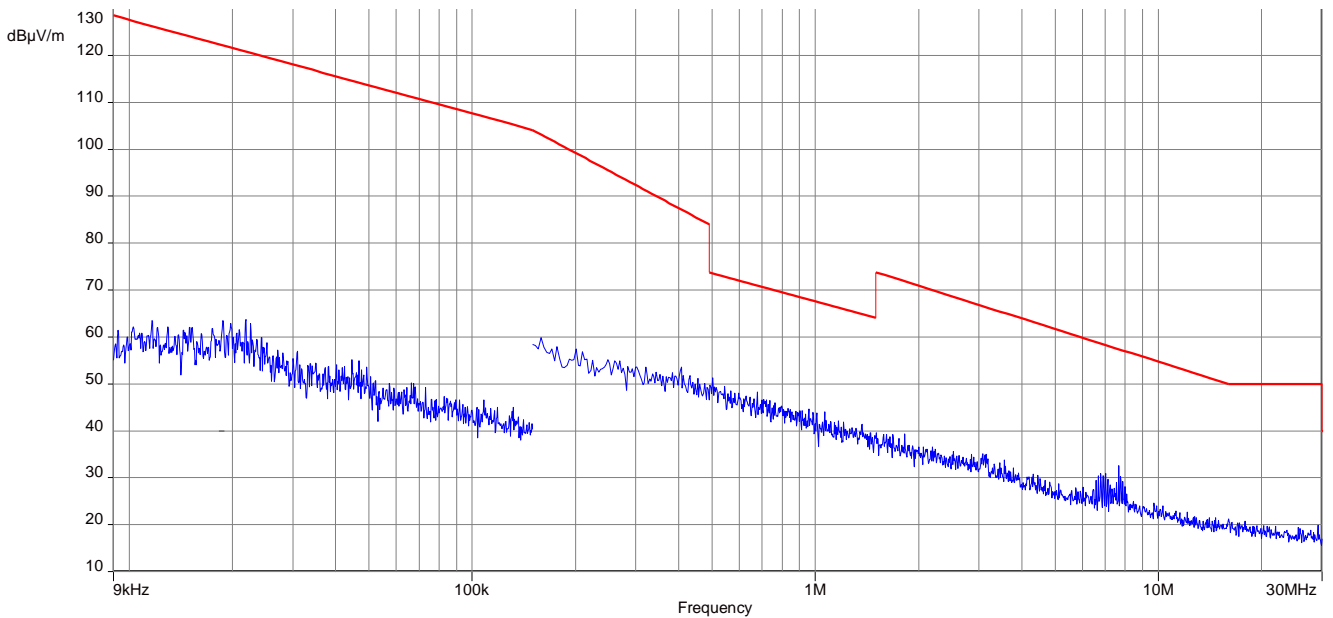

Plot 3: 9 kHz to 30 MHz, high channel

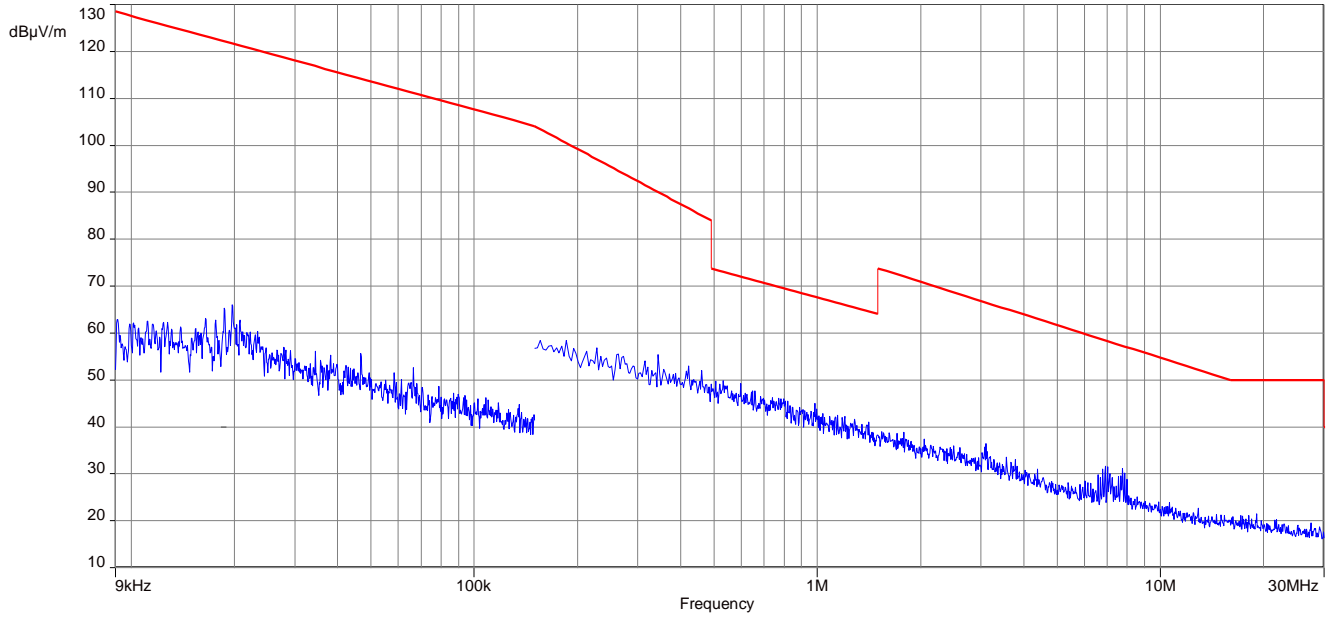

11.12 Spurious emissions radiated 30 MHz to 1 GHz

Description:

Measurement of the radiated spurious emissions and cabinet radiations below 1 GHz.

Measurement:

Measurement parameter	
Detector:	Peak / Quasi Peak
Sweep time:	Auto
Resolution bandwidth:	120 kHz
Video bandwidth:	3 x RBW
Span:	30 MHz to 1 GHz
Trace mode:	Max Hold
Measured modulation	<input checked="" type="checkbox"/> DSSS b – mode <input checked="" type="checkbox"/> OFDM g – mode <input type="checkbox"/> OFDM n HT20 – mode <input checked="" type="checkbox"/> OFDM n HT40 – mode <input checked="" type="checkbox"/> RX / Idle – mode
Test setup:	See sub clause 6.1 – A
Measurement uncertainty	See sub clause 8

The modulation with the highest output power was used to perform the transmitter spurious emissions. If spurious were detected a re-measurement was performed on the detected frequency with each modulation.

Limits:

FCC		IC	
In any 100 kHz bandwidth outside the frequency band in which the spread spectrum or digitally modulated intentional radiator is operating, the radio frequency power that is produced by the intentional radiator shall be at least 20 dB below that in the 100 kHz bandwidth within the band that contains the highest level of the desired power, based on either an RF conducted or a radiated measurement. Attenuation below the general limits specified in Section 15.209(a) is not required. In addition, radiated emissions which fall in the restricted bands, as defined in §15.205(a), must also comply with the radiated emission limits specified in §15.209(a) (see §15.205(c)).			
Frequency [MHz]	Field Strength [dBµV/m]	Measurement distance [m]	
30 - 88	30.0	10	
88 – 216	33.5	10	
216 – 960	36.0	10	

Results: (External antennas)

For the results of the spurious emission tests radiated of all external antennas see “Appendix_to_1-2846/16-02-04-B”

Plot: DSSS

Plot 1: 30 MHz to 1 GHz, vertical & horizontal polarization, low channel

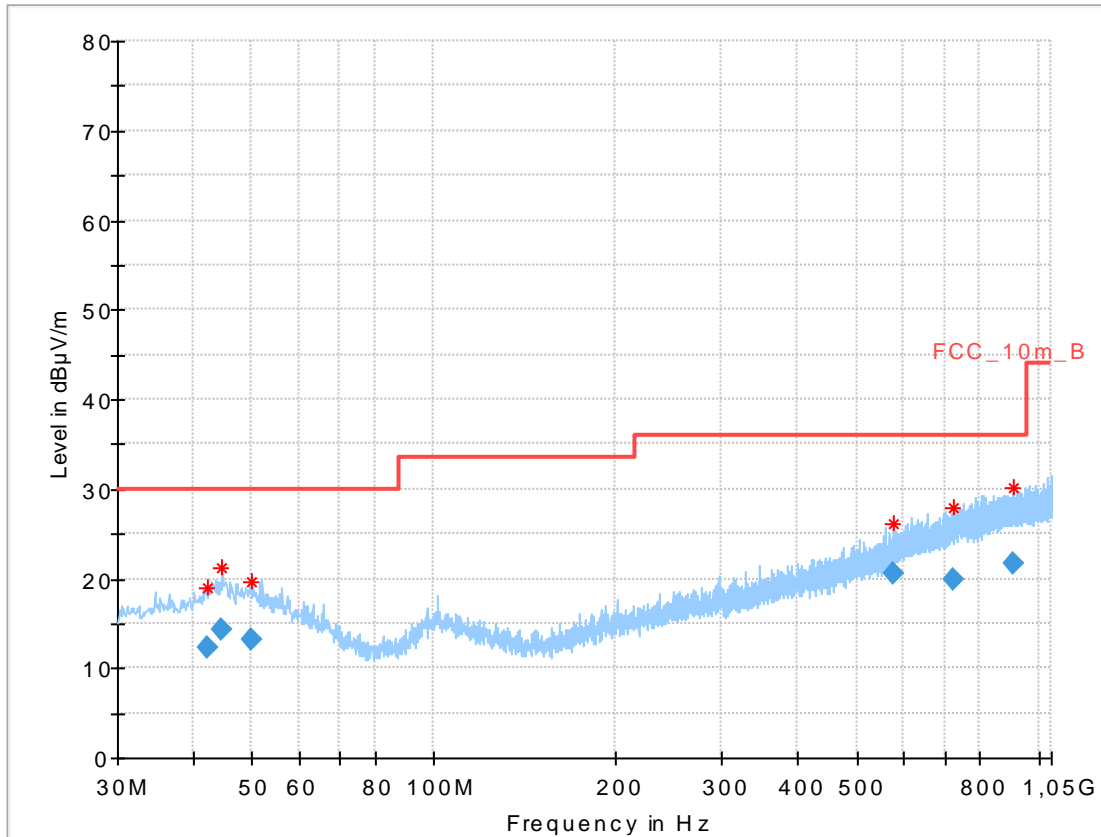

Final Result:

Frequency (MHz)	QuasiPeak (dBµV/m)	Limit (dBµV/m)	Margin (dB)	Meas. Time (ms)	Bandwidth (kHz)	Height (cm)	Pol	Azimuth (deg)	Corr. (dB)
42.261900	12.27	30.00	17.73	1000.0	120.000	101.0	V	158.0	13.4
44.486700	14.29	30.00	15.71	1000.0	120.000	101.0	V	158.0	13.6
50.098950	13.16	30.00	16.84	1000.0	120.000	101.0	V	235.0	13.7
575.972550	20.54	36.00	15.46	1000.0	120.000	180.0	H	293.0	20.1
723.902400	19.93	36.00	16.07	1000.0	120.000	101.0	H	14.0	22.1
907.164300	21.68	36.00	14.32	1000.0	120.000	101.0	V	227.0	24.2

Plot 2: 30 MHz to 1 GHz, vertical & horizontal polarization, mid channel

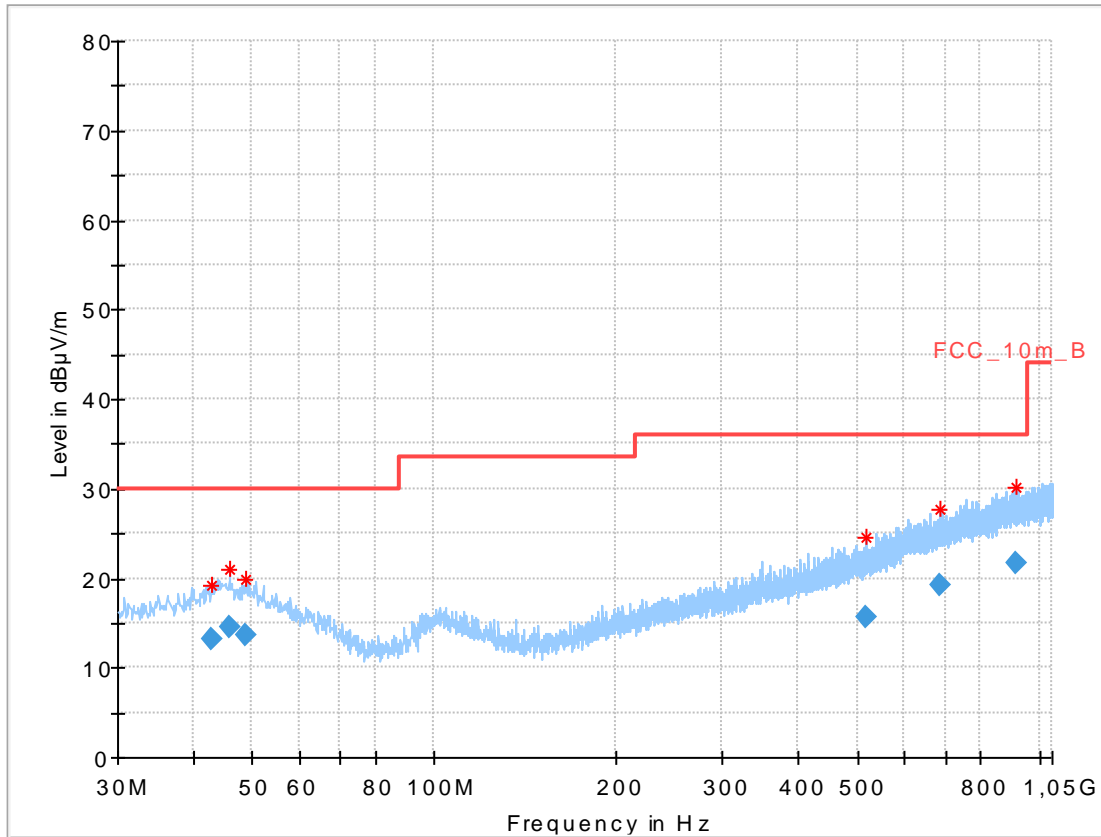

Final_Result:

Frequency (MHz)	QuasiPeak (dBµV/m)	Limit (dBµV/m)	Margin (dB)	Meas. Time (ms)	Bandwidth (kHz)	Height (cm)	Pol	Azimuth (deg)	Corr. (dB)
42.795600	13.22	30.00	16.78	1000.0	120.000	98.0	V	89.0	13.5
46.103100	14.61	30.00	15.39	1000.0	120.000	98.0	V	171.0	13.7
48.989250	13.56	30.00	16.44	1000.0	120.000	98.0	V	69.0	13.7
516.481200	15.59	36.00	20.41	1000.0	120.000	101.0	V	352.0	18.9
686.084250	19.20	36.00	16.80	1000.0	120.000	98.0	H	129.0	21.4
918.465750	21.68	36.00	14.32	1000.0	120.000	185.0	V	20.0	24.2

Plot 3: 30 MHz to 1 GHz, vertical & horizontal polarization, high channel

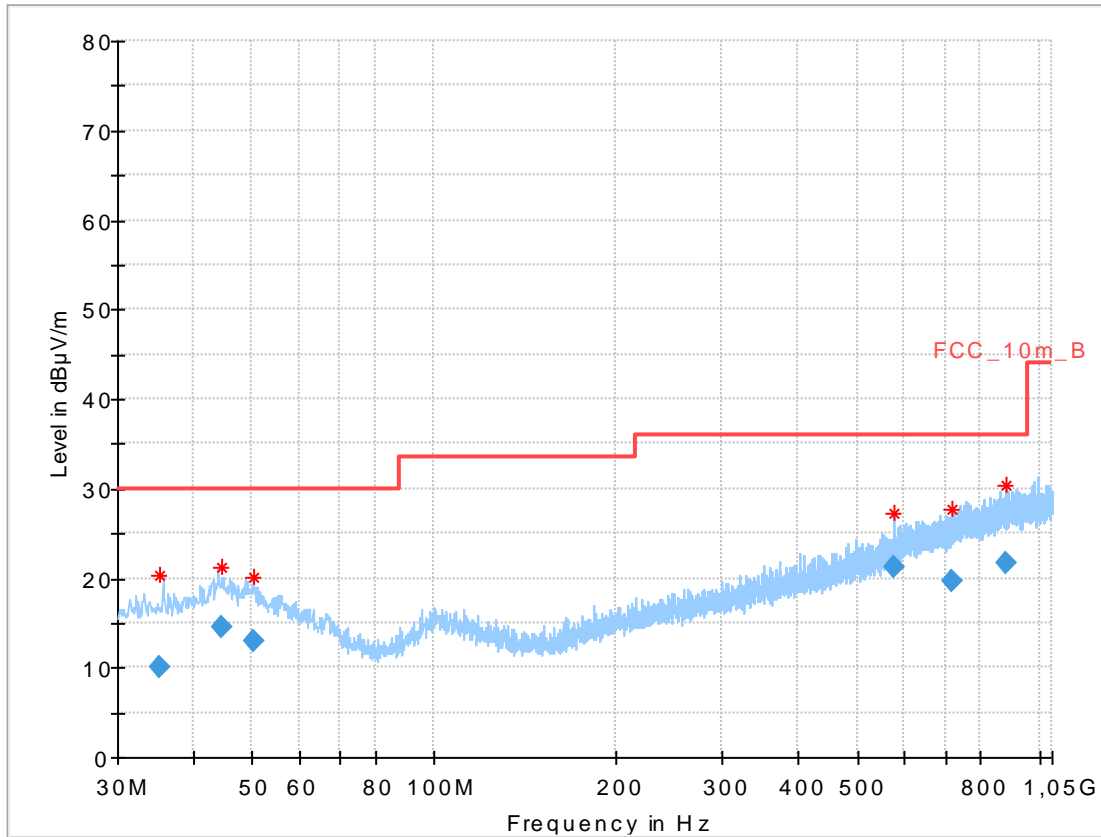

Final_Result:

Frequency (MHz)	QuasiPeak (dBµV/m)	Limit (dBµV/m)	Margin (dB)	Meas. Time (ms)	Bandwidth (kHz)	Height (cm)	Pol	Azimuth (deg)	Corr. (dB)
35.121450	10.11	30.00	19.89	1000.0	120.000	105.0	V	60.0	12.7
44.575650	14.60	30.00	15.40	1000.0	120.000	98.0	V	176.0	13.6
50.359200	12.92	30.00	17.08	1000.0	120.000	98.0	V	190.0	13.7
576.001350	21.26	36.00	14.74	1000.0	120.000	178.0	V	87.0	20.1
715.501500	19.71	36.00	16.29	1000.0	120.000	98.0	V	234.0	21.9
884.513100	21.66	36.00	14.34	1000.0	120.000	180.0	H	0.0	24.0

Plot: OFDM (20 MHz bandwidth)

Plot 1: 30 MHz to 1 GHz, vertical & horizontal polarization, low channel

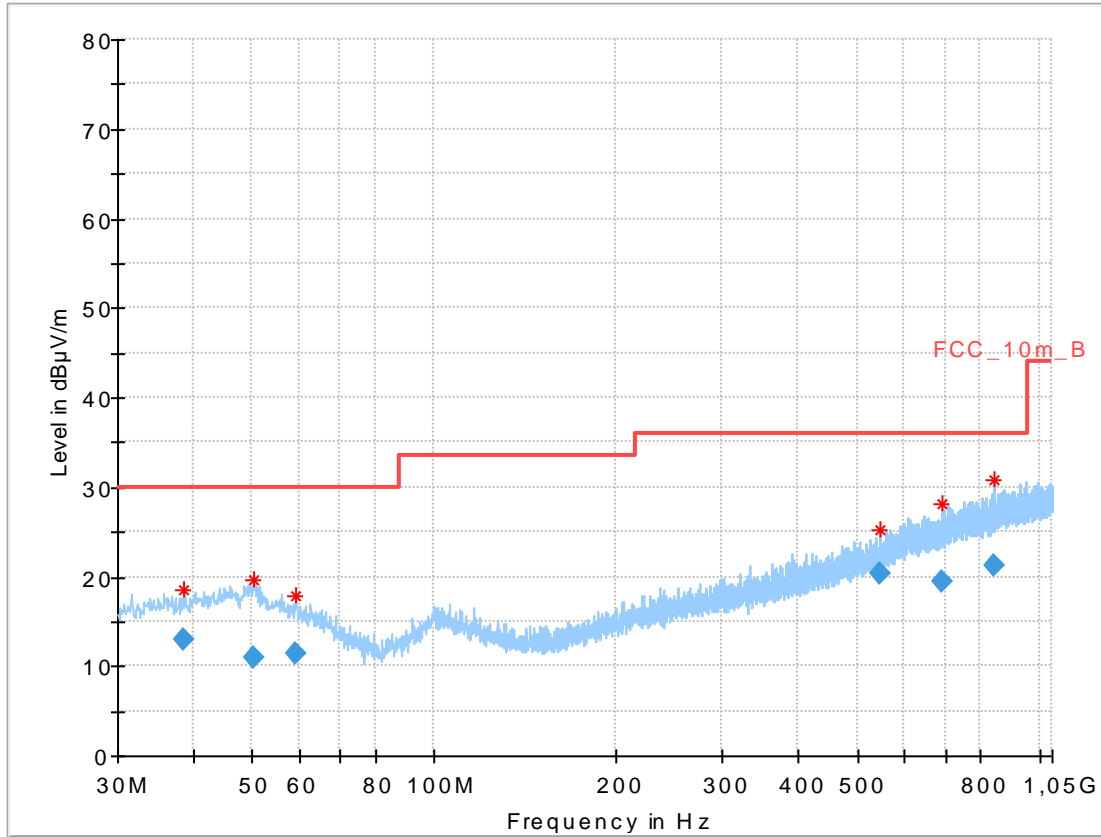

Final_Result:

Frequency (MHz)	QuasiPeak (dBµV/m)	Limit (dBµV/m)	Margin (dB)	Meas. Time (ms)	Bandwidth (kHz)	Height (cm)	Pol	Azimuth (deg)	Corr. (dB)
38.686350	13.07	30.00	16.93	1000.0	120.000	101.0	V	178.0	13.1
50.488200	10.89	30.00	19.11	1000.0	120.000	185.0	H	116.0	13.7
58.965600	11.42	30.00	18.58	1000.0	120.000	101.0	V	321.0	12.1
544.013700	20.37	36.00	15.63	1000.0	120.000	185.0	V	275.0	19.3
689.670600	19.34	36.00	16.66	1000.0	120.000	178.0	V	35.0	21.5
844.705500	21.25	36.00	14.75	1000.0	120.000	101.0	H	0.0	23.5

Plot 2: 30 MHz to 1 GHz, vertical & horizontal polarization, mid channel

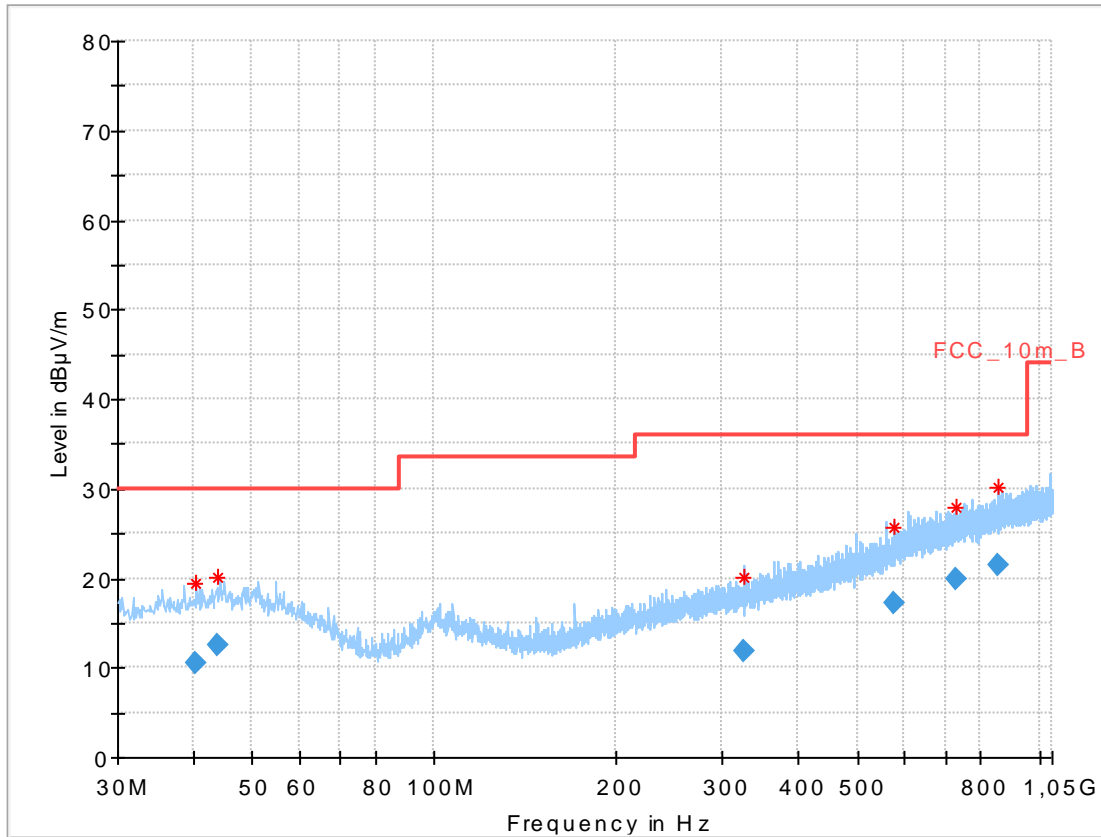

Final_Result:

Frequency (MHz)	QuasiPeak (dBµV/m)	Limit (dBµV/m)	Margin (dB)	Meas. Time (ms)	Bandwidth (kHz)	Height (cm)	Pol	Azimuth (deg)	Corr. (dB)
40.280400	10.58	30.00	19.42	1000.0	120.000	101.0	H	15.0	13.2
43.856100	12.62	30.00	17.38	1000.0	120.000	101.0	V	222.0	13.5
325.958700	11.82	36.00	24.18	1000.0	120.000	185.0	H	88.0	15.3
574.402050	17.10	36.00	18.90	1000.0	120.000	101.0	H	312.0	20.0
726.847500	19.92	36.00	16.08	1000.0	120.000	178.0	H	140.0	22.2
857.314200	21.42	36.00	14.58	1000.0	120.000	101.0	H	101.0	23.6

Plot 3: 30 MHz to 1 GHz, vertical & horizontal polarization, high channel

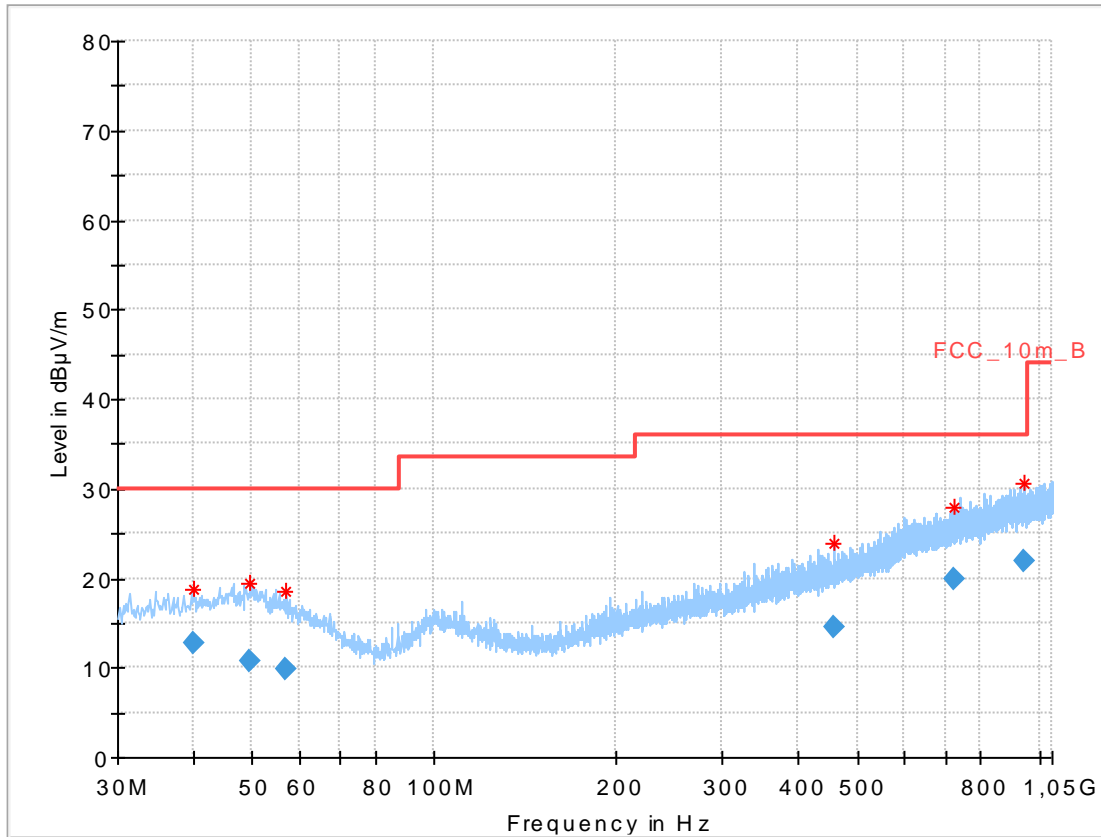

Final_Result:

Frequency (MHz)	QuasiPeak (dBµV/m)	Limit (dBµV/m)	Margin (dB)	Meas. Time (ms)	Bandwidth (kHz)	Height (cm)	Pol	Azimuth (deg)	Corr. (dB)
40.008150	12.76	30.00	17.24	1000.0	120.000	101.0	V	346.0	13.2
49.753350	10.68	30.00	19.32	1000.0	120.000	98.0	H	127.0	13.7
56.657400	9.83	30.00	20.17	1000.0	120.000	179.0	V	346.0	12.7
458.069100	14.57	36.00	21.43	1000.0	120.000	185.0	V	182.0	17.8
725.609550	19.91	36.00	16.09	1000.0	120.000	185.0	V	220.0	22.2
944.989350	21.82	36.00	14.18	1000.0	120.000	101.0	V	352.0	24.3

Plot: OFDM (40 MHz bandwidth)

Plot 1: 30 MHz to 1 GHz, vertical & horizontal polarization, low channel

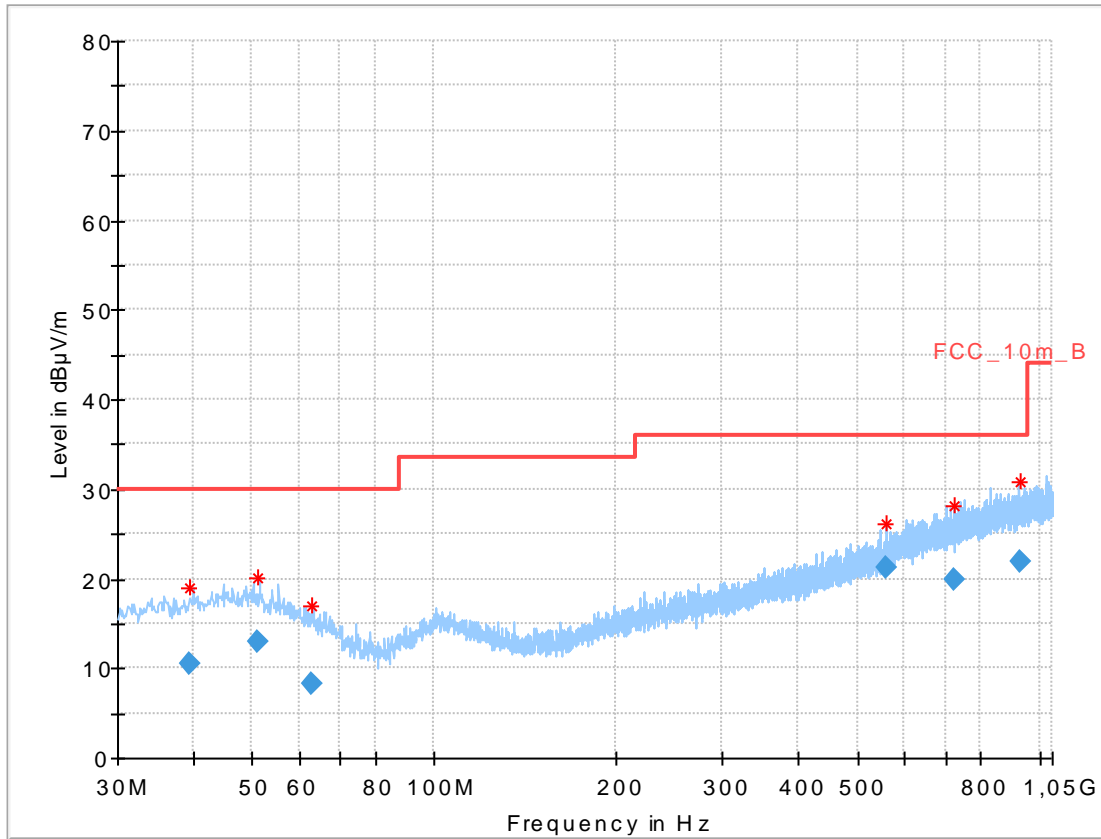

Final_Result:

Frequency (MHz)	QuasiPeak (dBµV/m)	Limit (dBµV/m)	Margin (dB)	Meas. Time (ms)	Bandwidth (kHz)	Height (cm)	Pol	Azimuth (deg)	Corr. (dB)
39.414300	10.43	30.00	19.57	1000.0	120.000	98.0	V	134.0	13.1
50.993550	12.87	30.00	17.13	1000.0	120.000	98.0	V	347.0	13.6
62.585100	8.23	30.00	21.77	1000.0	120.000	185.0	H	155.0	11.3
560.022450	21.27	36.00	14.73	1000.0	120.000	178.0	V	73.0	19.6
725.470650	19.94	36.00	16.06	1000.0	120.000	178.0	H	125.0	22.2
926.414100	21.84	36.00	14.16	1000.0	120.000	101.0	H	311.0	24.3

Plot 2: 30 MHz to 1 GHz, vertical & horizontal polarization, mid channel

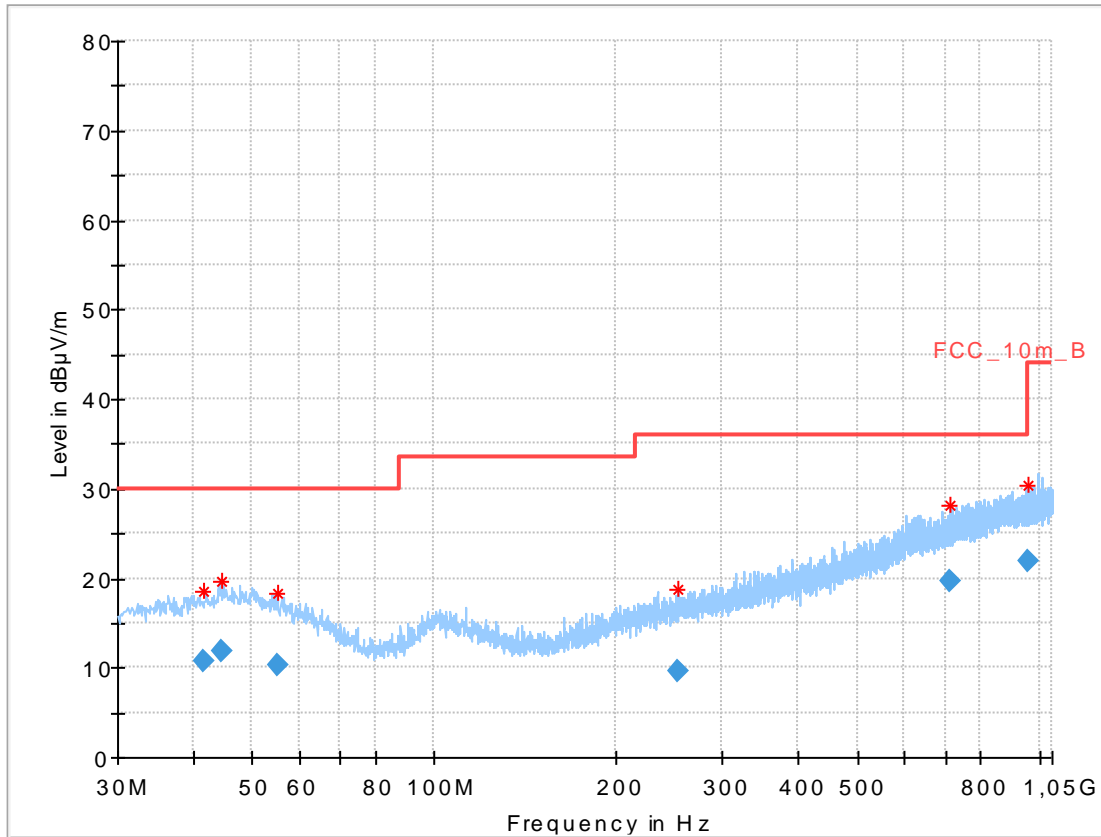

Final_Result:

Frequency (MHz)	QuasiPeak (dBµV/m)	Limit (dBµV/m)	Margin (dB)	Meas. Time (ms)	Bandwidth (kHz)	Height (cm)	Pol	Azimuth (deg)	Corr. (dB)
41.775300	10.73	30.00	19.27	1000.0	120.000	101.0	V	196.0	13.4
44.445000	11.92	30.00	18.08	1000.0	120.000	98.0	V	57.0	13.6
54.963300	10.18	30.00	19.82	1000.0	120.000	101.0	V	299.0	13.1
252.567450	9.66	36.00	26.34	1000.0	120.000	178.0	H	57.0	13.5
711.199500	19.62	36.00	16.38	1000.0	120.000	185.0	V	292.0	21.8
958.862400	21.97	36.00	14.03	1000.0	120.000	101.0	H	280.0	24.4

Plot 3: 30 MHz to 1 GHz, vertical & horizontal polarization, high channel

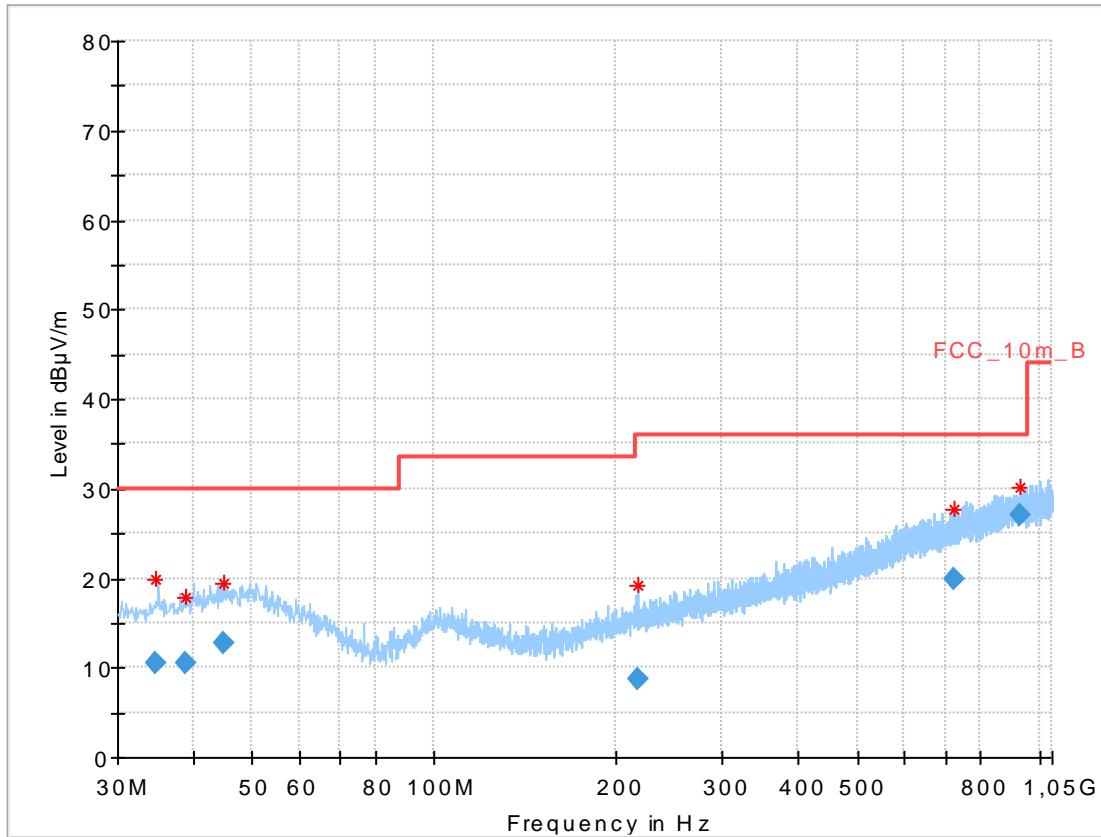

Final_Result:

Frequency (MHz)	QuasiPeak (dBµV/m)	Limit (dBµV/m)	Margin (dB)	Meas. Time (ms)	Bandwidth (kHz)	Height (cm)	Pol	Azimuth (deg)	Corr. (dB)
34.630200	10.60	30.00	19.40	1000.0	120.000	101.0	V	21.0	12.6
38.990700	10.44	30.00	19.56	1000.0	120.000	98.0	V	263.0	13.1
45.002550	12.64	30.00	17.36	1000.0	120.000	98.0	V	218.0	13.6
217.661550	8.70	36.00	27.30	1000.0	120.000	185.0	V	218.0	12.5
723.833700	19.92	36.00	16.08	1000.0	120.000	98.0	H	296.0	22.1
927.355050	27.09	36.00	8.91	1000.0	120.000	181.0	V	69.0	24.3

Plot: RX / Idle mode

Plot 1: 30 MHz to 1 GHz, vertical & horizontal polarization

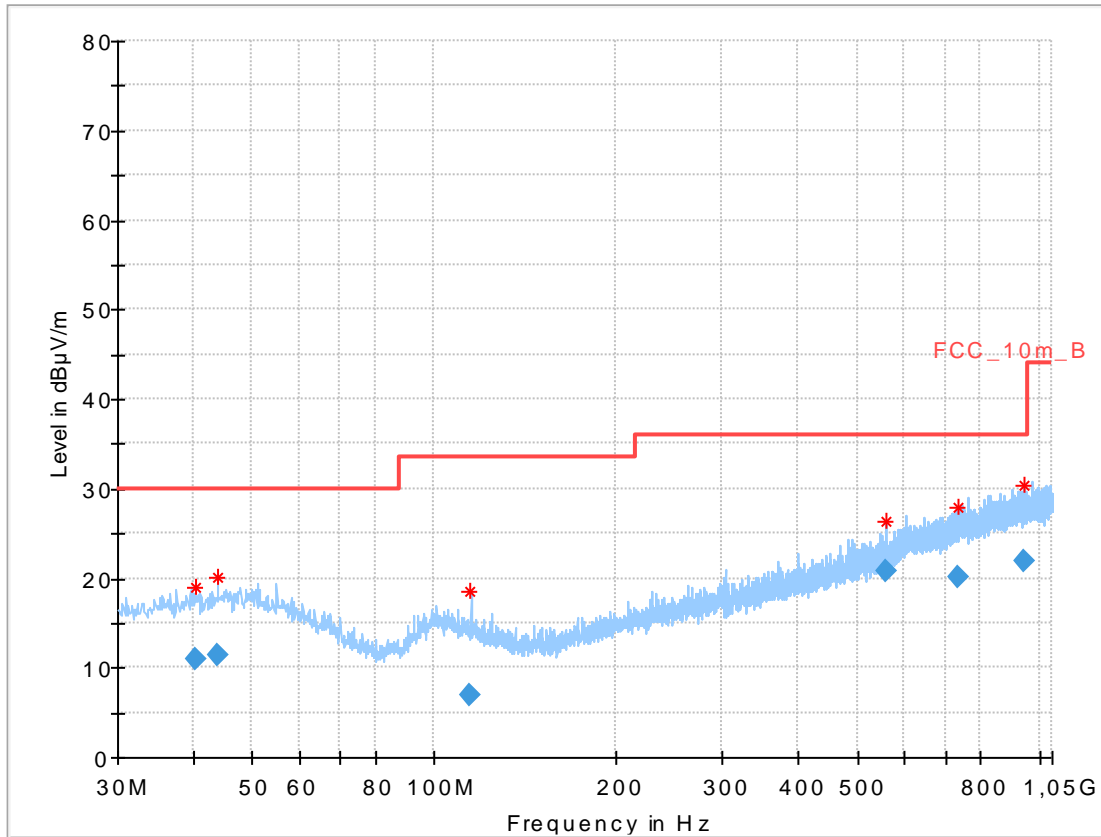

Final_Result.

Frequency (MHz)	QuasiPeak (dBµV/m)	Limit (dBµV/m)	Margin (dB)	Meas. Time (ms)	Bandwidth (kHz)	Height (cm)	Pol	Azimuth (deg)	Corr. (dB)
40.235550	10.90	30.00	19.10	1000.0	120.000	101.0	V	160.0	13.2
44.044800	11.45	30.00	18.55	1000.0	120.000	98.0	V	53.0	13.6
114.691050	6.89	33.50	26.61	1000.0	120.000	178.0	V	133.0	10.7
560.028450	20.83	36.00	15.17	1000.0	120.000	98.0	H	79.0	19.6
735.209850	20.18	36.00	15.82	1000.0	120.000	185.0	V	351.0	22.4
946.729500	21.83	36.00	14.17	1000.0	120.000	98.0	H	27.0	24.3

11.13 Spurious emissions radiated above 1 GHz

Description:

Measurement of the radiated spurious emissions above 1 GHz in transmit mode and receiver / idle mode.

Measurement:

Measurement parameter	
Detector:	Peak / RMS
Sweep time:	Auto
Resolution bandwidth:	1 MHz
Video bandwidth:	3 x RBW
Span:	1 GHz to 26 GHz
Trace mode:	Max Hold
Measured modulation	<input checked="" type="checkbox"/> DSSS b – mode <input checked="" type="checkbox"/> OFDM g – mode <input type="checkbox"/> OFDM n HT20 – mode <input checked="" type="checkbox"/> OFDM n HT40 – mode <input checked="" type="checkbox"/> RX / Idle – mode
Test setup:	See sub clause 6.2 – B See sub clause 6.3 – A
Measurement uncertainty	See sub clause 8

Limits:

FCC		IC
In any 100 kHz bandwidth outside the frequency band in which the spread spectrum or digitally modulated intentional radiator is operating, the radio frequency power that is produced by the intentional radiator shall be at least 30 dB below that in the 100 kHz bandwidth within the band that contains the highest level of the desired power, based on either an RF conducted or a radiated measurement. Attenuation below the general limits specified in Section 15.209(a) is not required. In addition, radiated emissions which fall in the restricted bands, as defined in §15.205(a), must also comply with the radiated emission limits specified in §15.209(a) (see §15.205(c)).		
Frequency [MHz]	Field Strength [dBµV/m]	Measurement distance [m]
Above 960	54.0	3

Results: (External antennas)

For the results of the spurious emission tests radiated of all external antennas see “Appendix_to_1-2846/16-02-04-B”

Results: DSSS

TX Spurious Emissions Radiated [dBµV/m]								
2412 MHz			2437 MHz			2462 MHz		
F [MHz]	Detector	Level [dBµV/m]	F [MHz]	Detector	Level [dBµV/m]	F [MHz]	Detector	Level [dBµV/m]
4824	Peak	55.8	4874	Peak	55.7	4924	Peak	53.7
	AVG	49.1		AVG	48.7		AVG	44.3
-/-	Peak	-/-	-/-	Peak	-/-	-/-	Peak	-/-
	AVG	-/-		AVG	-/-		AVG	-/-

Results: OFDM (20 MHz bandwidth)

TX Spurious Emissions Radiated [dBµV/m]								
2412 MHz			2437 MHz			2462 MHz		
F [MHz]	Detector	Level [dBµV/m]	F [MHz]	Detector	Level [dBµV/m]	F [MHz]	Detector	Level [dBµV/m]
All detected emissions are more than 20 dB below the limit.			All detected emissions are more than 20 dB below the limit.			All detected emissions are more than 20 dB below the limit.		
-/-	Peak	-/-	-/-	Peak	-/-	-/-	Peak	-/-
	AVG	-/-		AVG	-/-		AVG	-/-
-/-	Peak	-/-	-/-	Peak	-/-	-/-	Peak	-/-
	AVG	-/-		AVG	-/-		AVG	-/-

Results: OFDM (40 MHz bandwidth)

TX Spurious Emissions Radiated [dBµV/m]								
2412 MHz			2437 MHz			2462 MHz		
F [MHz]	Detector	Level [dBµV/m]	F [MHz]	Detector	Level [dBµV/m]	F [MHz]	Detector	Level [dBµV/m]
All detected emissions are more than 20 dB below the limit.			All detected emissions are more than 20 dB below the limit.			All detected emissions are more than 20 dB below the limit.		
-/-	Peak	-/-	-/-	Peak	-/-	-/-	Peak	-/-
	AVG	-/-		AVG	-/-		AVG	-/-
-/-	Peak	-/-	-/-	Peak	-/-	-/-	Peak	-/-
	AVG	-/-		AVG	-/-		AVG	-/-

Results: RX / idle – mode

TX Spurious Emissions Radiated [dBµV/m]		
F [MHz]	Detector	Level [dBµV/m]
All detected emissions are more than 20 dB below the limit.		
-/-	Peak	-/-
	AVG	-/-
-/-	Peak	-/-
	AVG	-/-

Plots: DSSS

Plot 1: Lowest channel, 1 GHz to 7 GHz, vertical & horizontal polarization

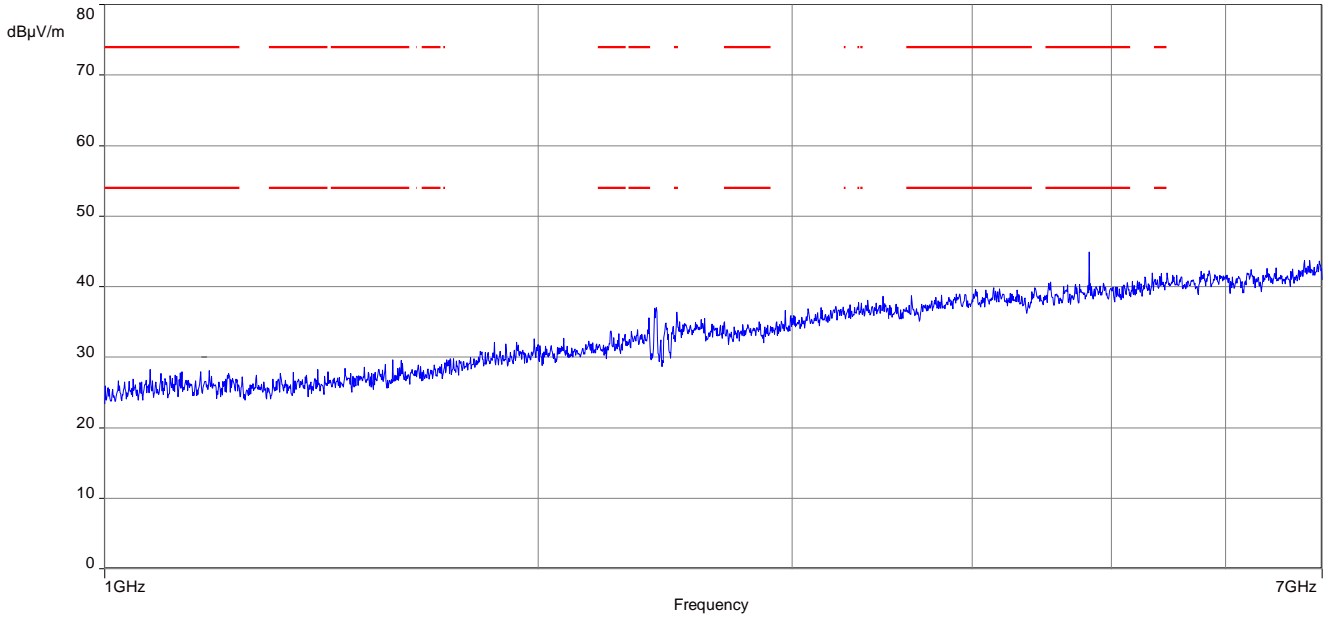

The carrier signal is notched with a 2.4 GHz band rejection filter.

Plot 2: Lowest channel, 7 GHz to 18 GHz, vertical & horizontal polarization

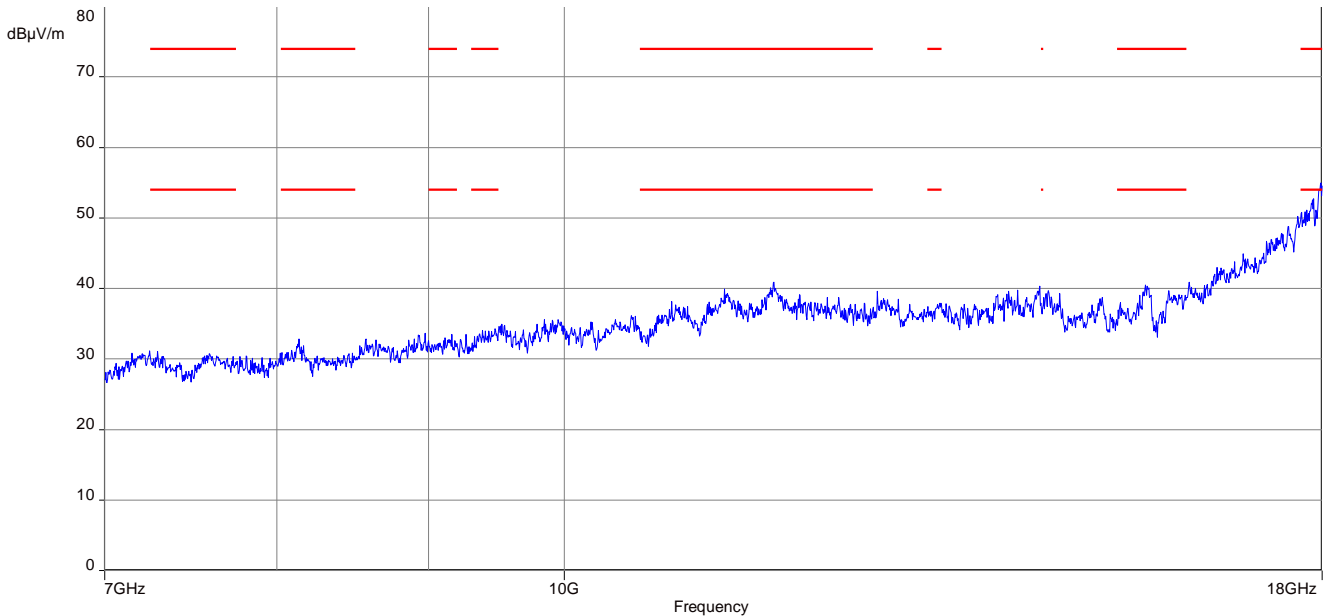

Plot 3: Lowest channel, 17.7 GHz to 18 GHz, vertical & horizontal polarization, peak & average

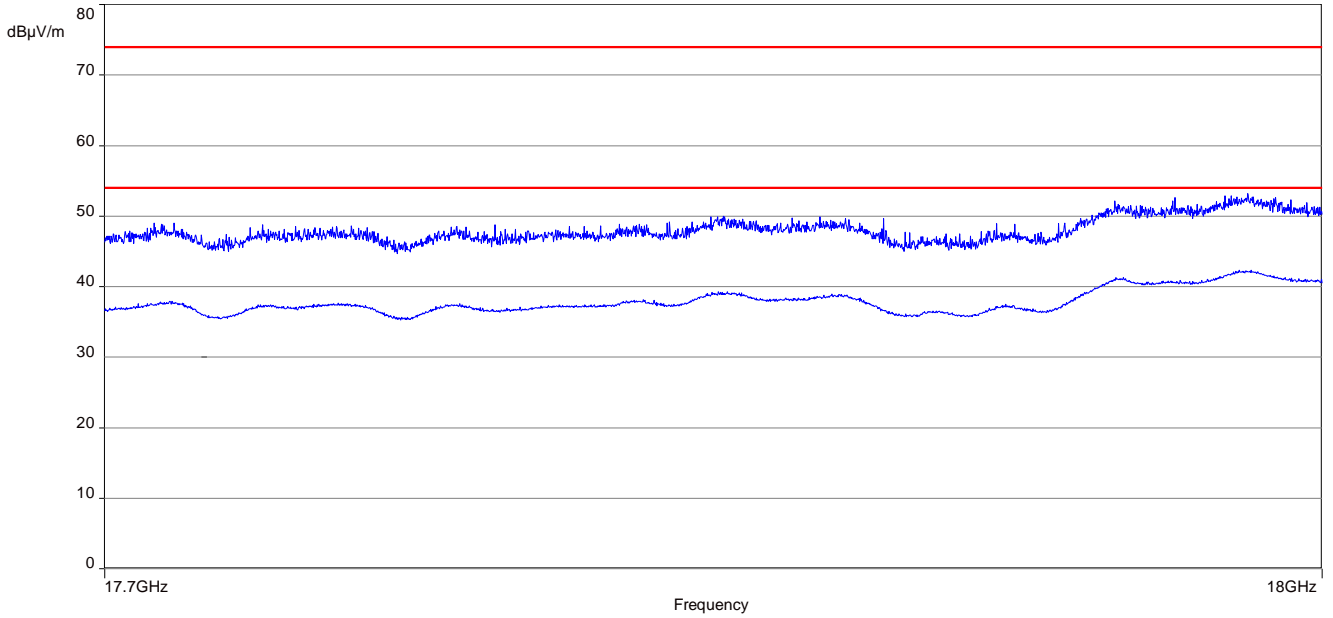

Plot 4: Lowest channel, 18 GHz to 26 GHz, vertical & horizontal polarization

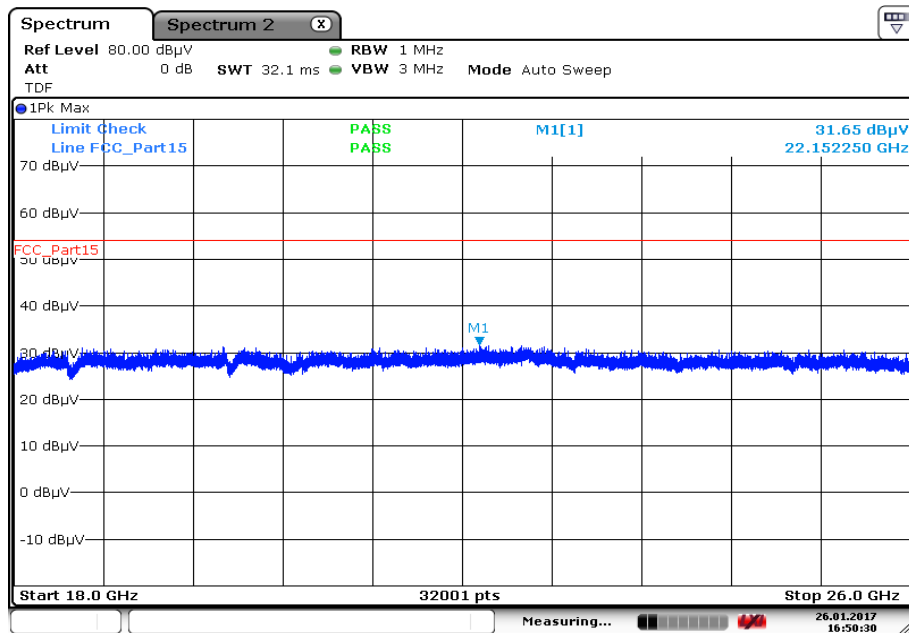

Plot 5: Middle channel, 1 GHz to 7 GHz, vertical & horizontal polarization

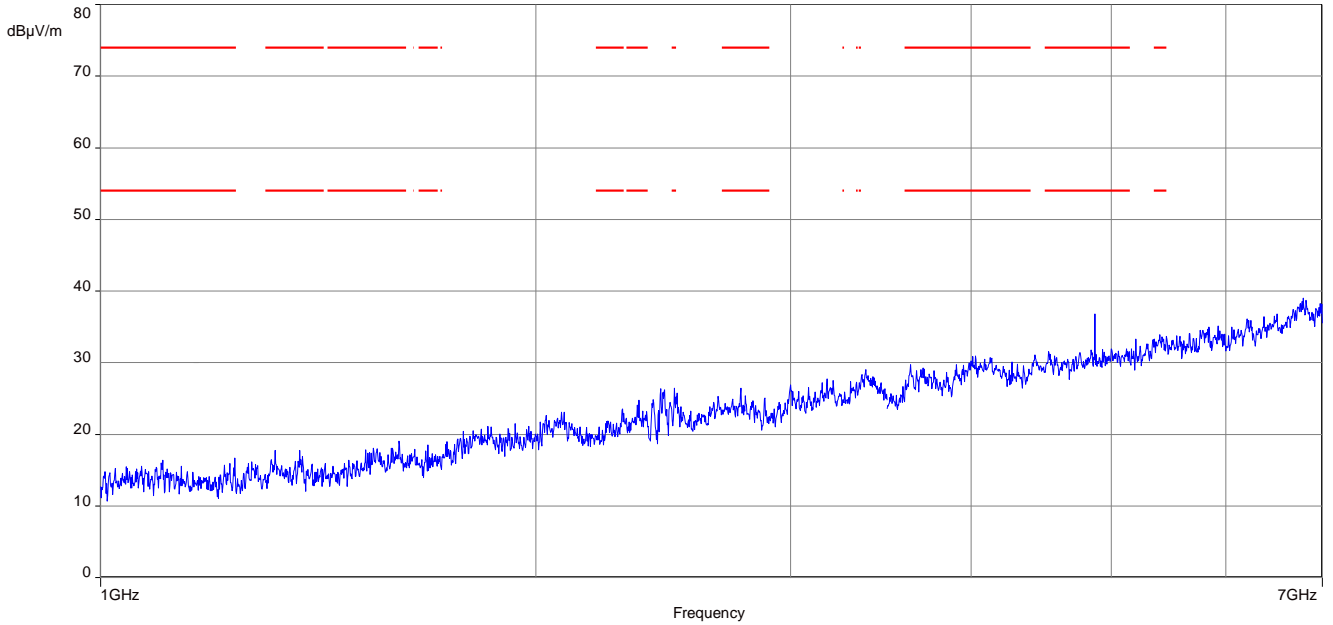

The carrier signal is notched with a 2.4 GHz band rejection filter.

Plot 6: Middle channel, 7 GHz to 18 GHz, vertical & horizontal polarization

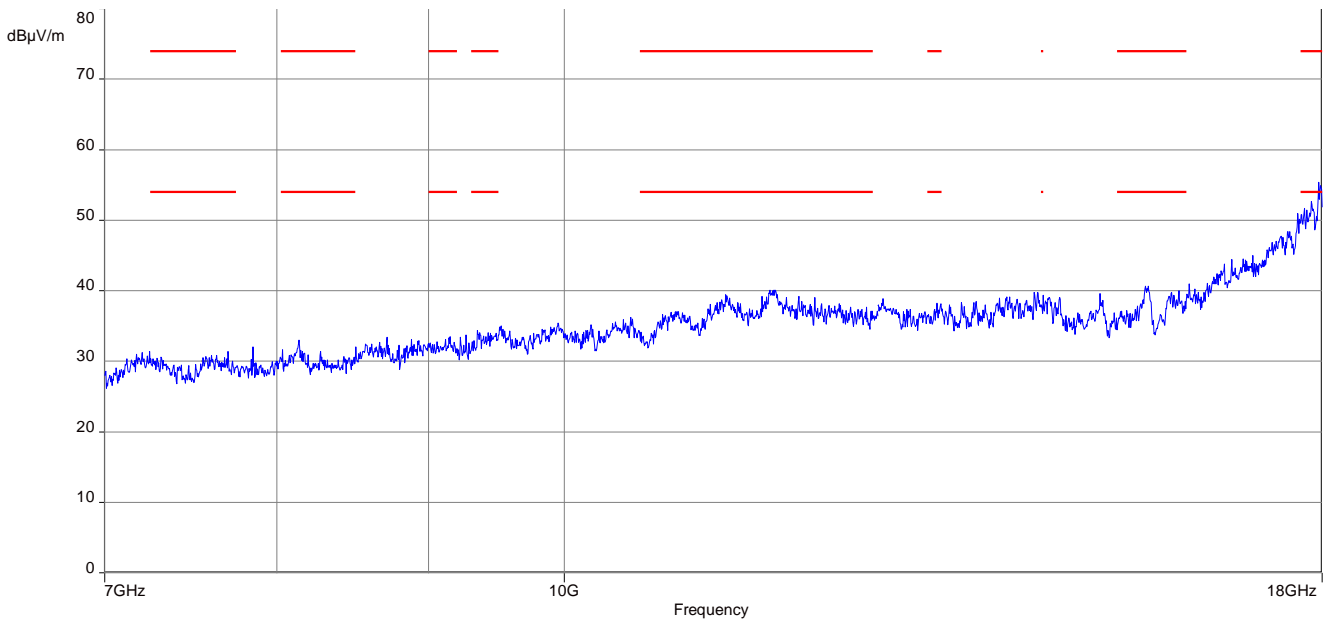

Plot 7: Middle channel, 17.7 GHz to 18 GHz, vertical & horizontal polarization

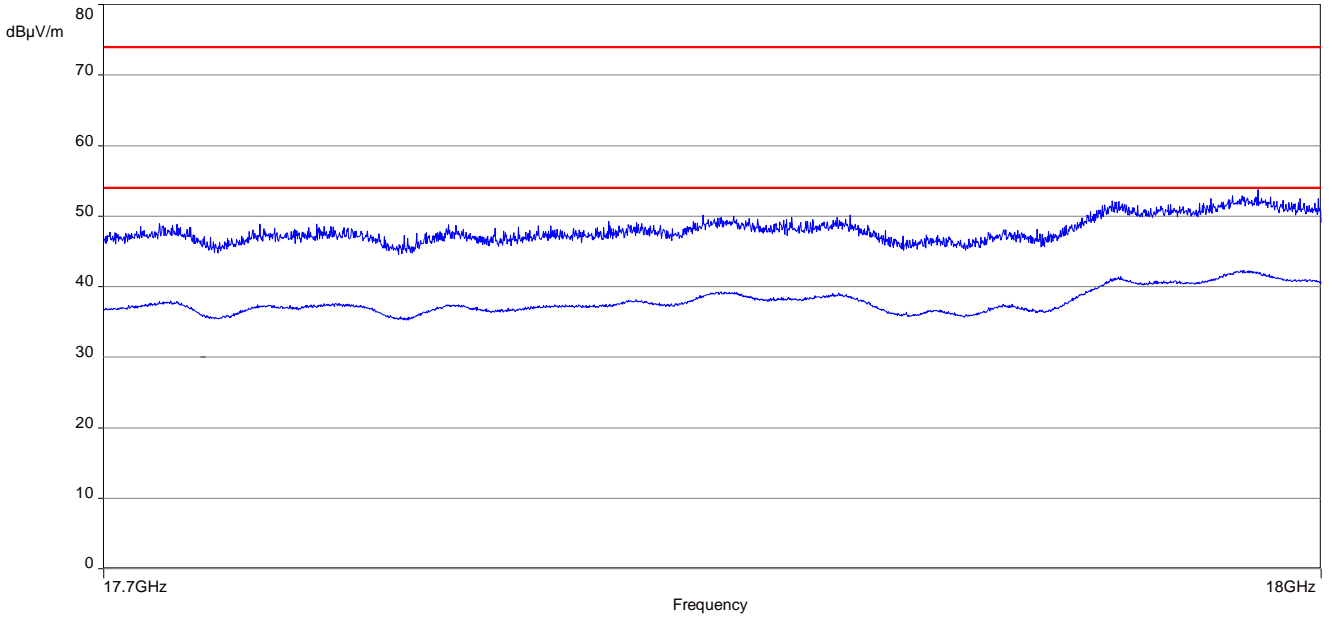

Plot 8: Middle channel, 18 GHz to 26 GHz, vertical & horizontal polarization

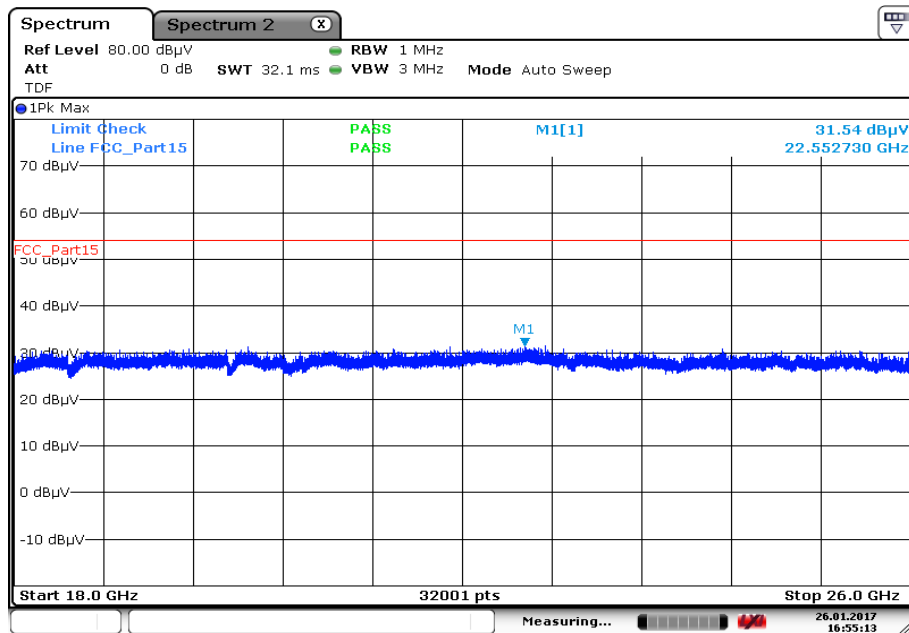

Date: 26.JAN.2017 16:55:12

Plot 9: Highest channel, 1 GHz to 7 GHz, vertical & horizontal polarization

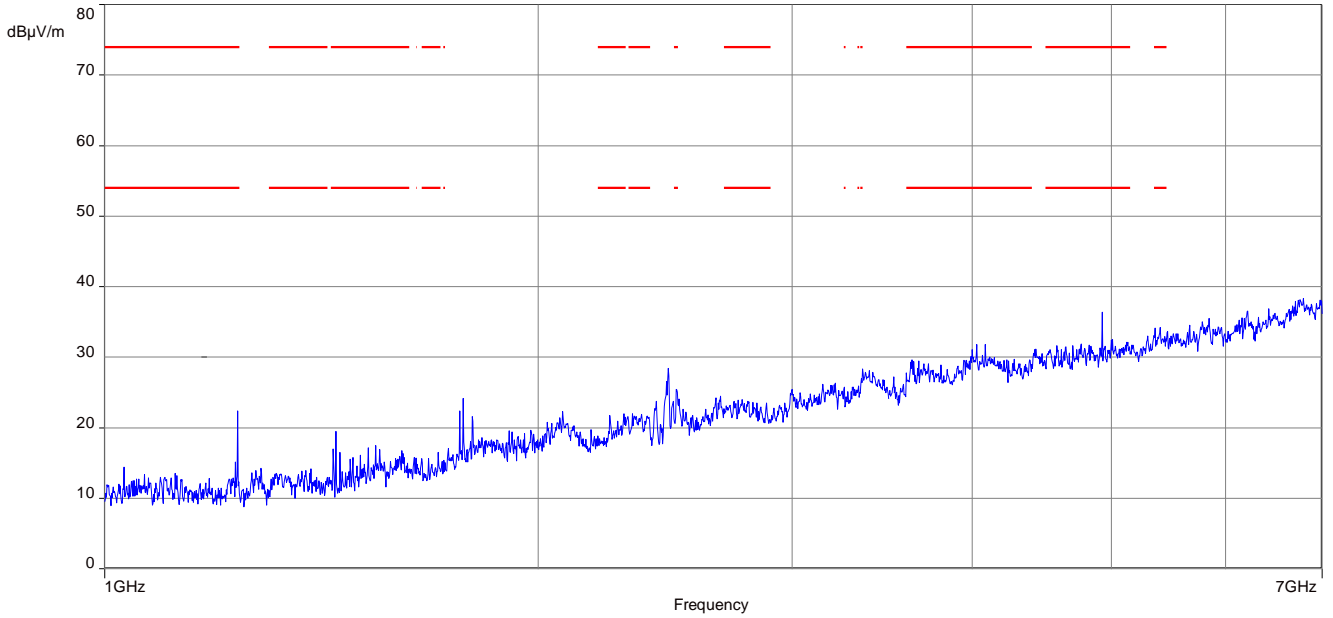

The carrier signal is notched with a 2.4 GHz band rejection filter.

Plot 9: Highest channel, 7 GHz to 18 GHz, vertical & horizontal polarization

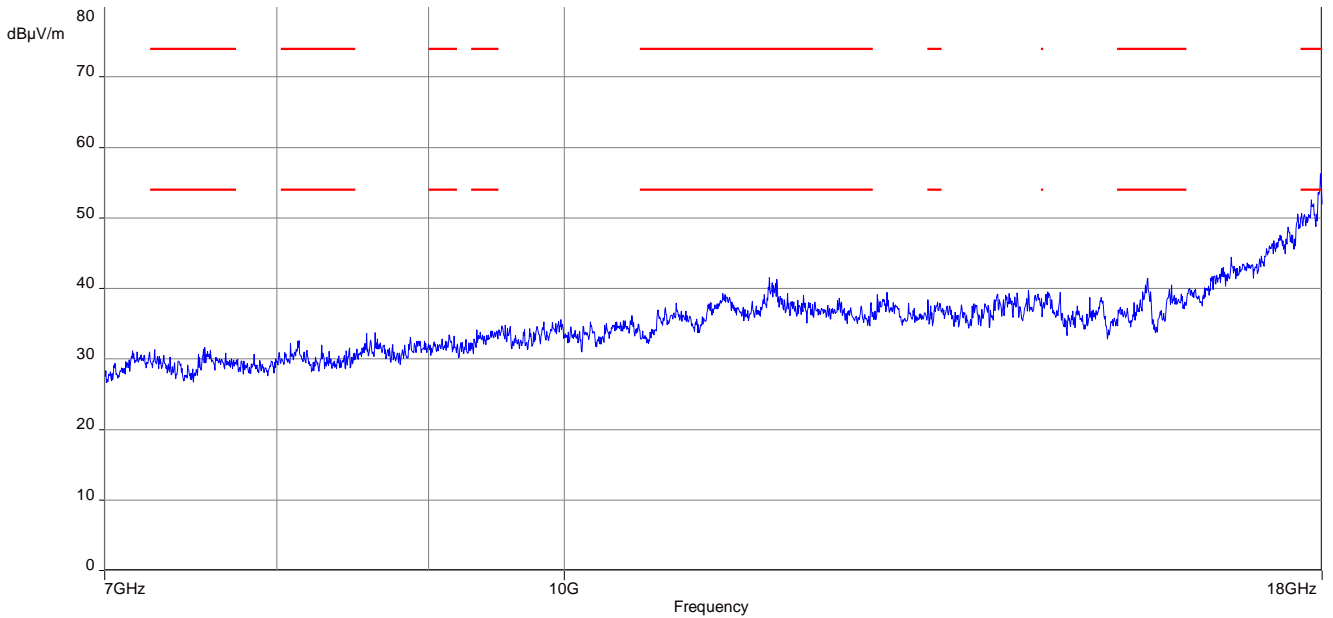

Plot 10: Highest channel, 17.7 GHz to 18 GHz, vertical & horizontal polarization

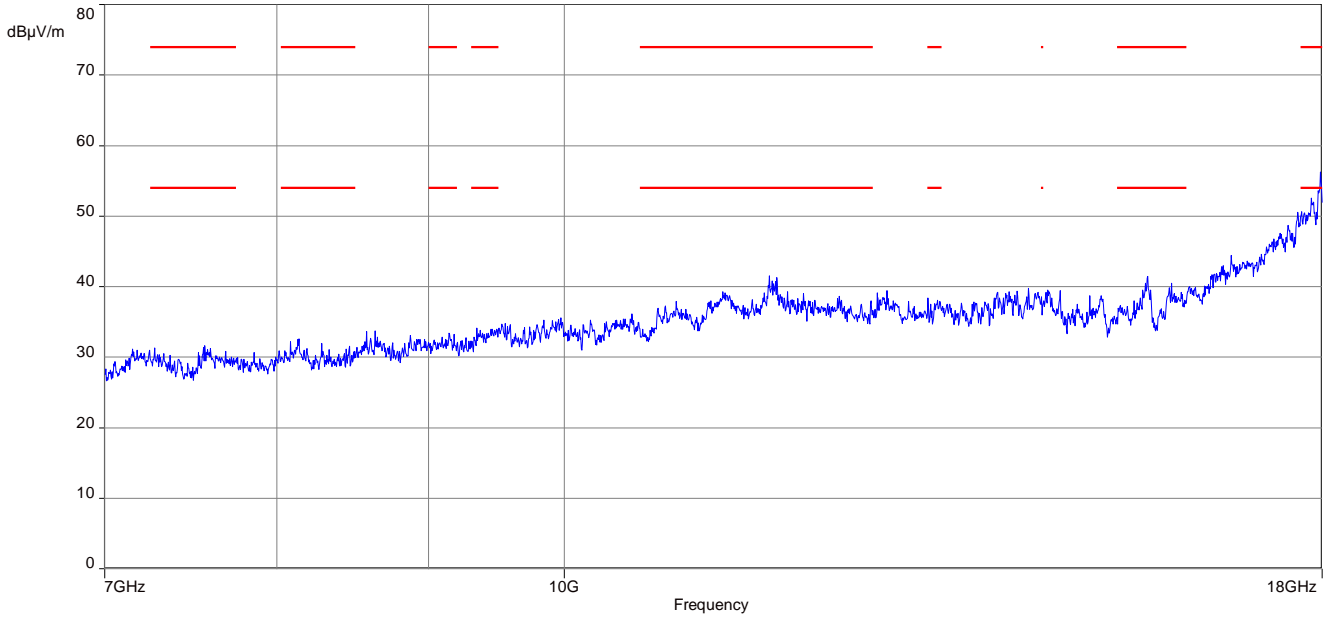

Plot 11: Highest channel, 18 GHz to 26 GHz, vertical & horizontal polarization

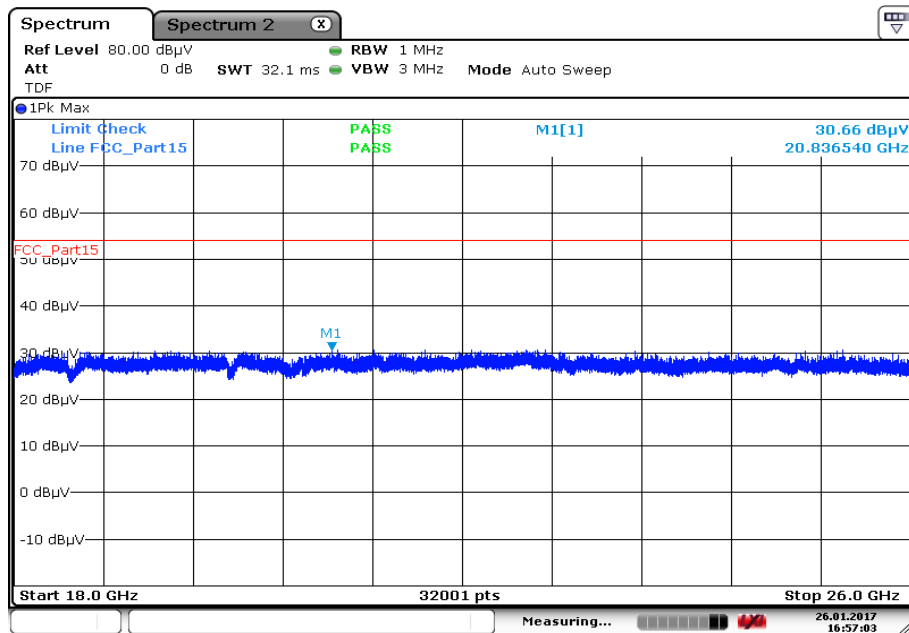

Date: 26.JAN.2017 16:57:03

Plots: OFDM (20 MHz bandwidth)

Plot 1: Lowest channel, 1 GHz to 7 GHz, vertical & horizontal polarization

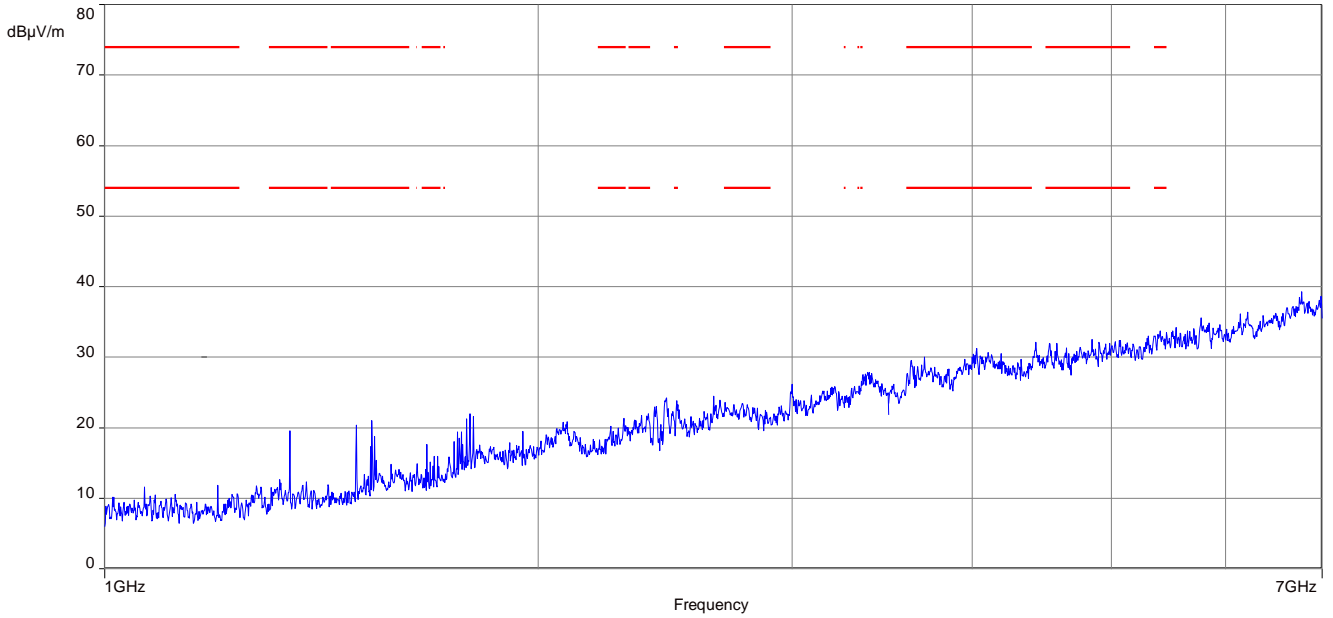

The carrier signal is notched with a 2.4 GHz band rejection filter.

Plot 2: Lowest channel, 7 GHz to 18 GHz, vertical & horizontal polarization

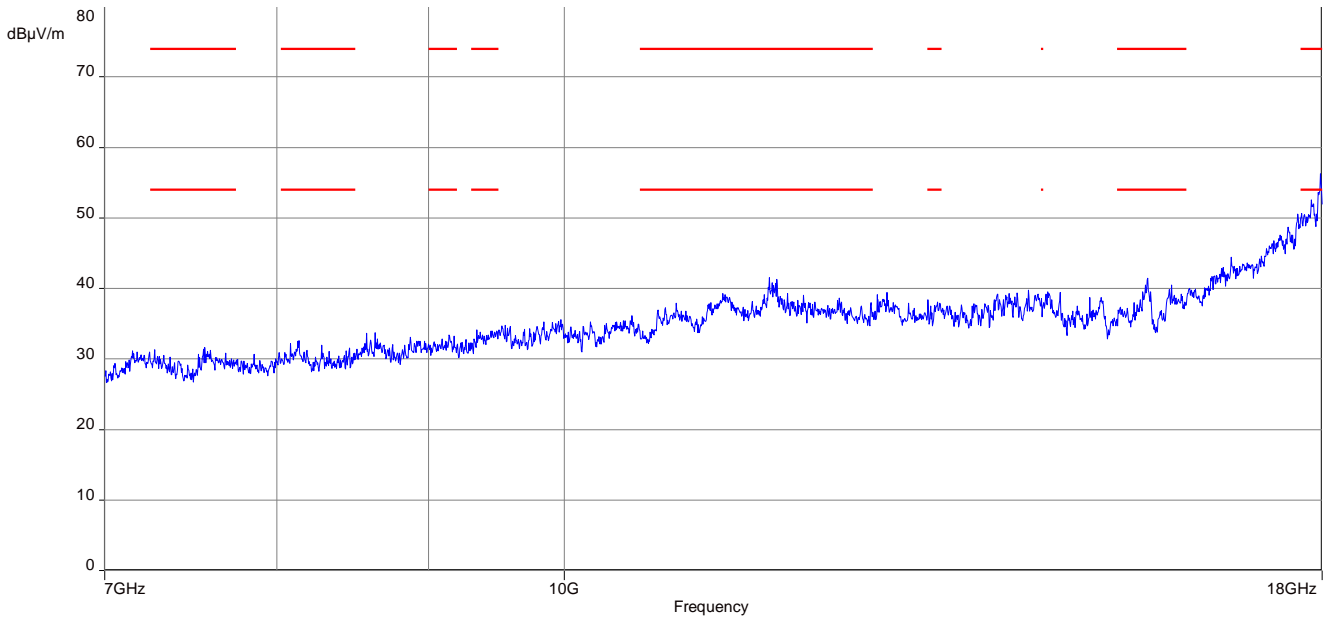

Plot 3: Lowest channel, 17.7 GHz to 18 GHz, vertical & horizontal polarization

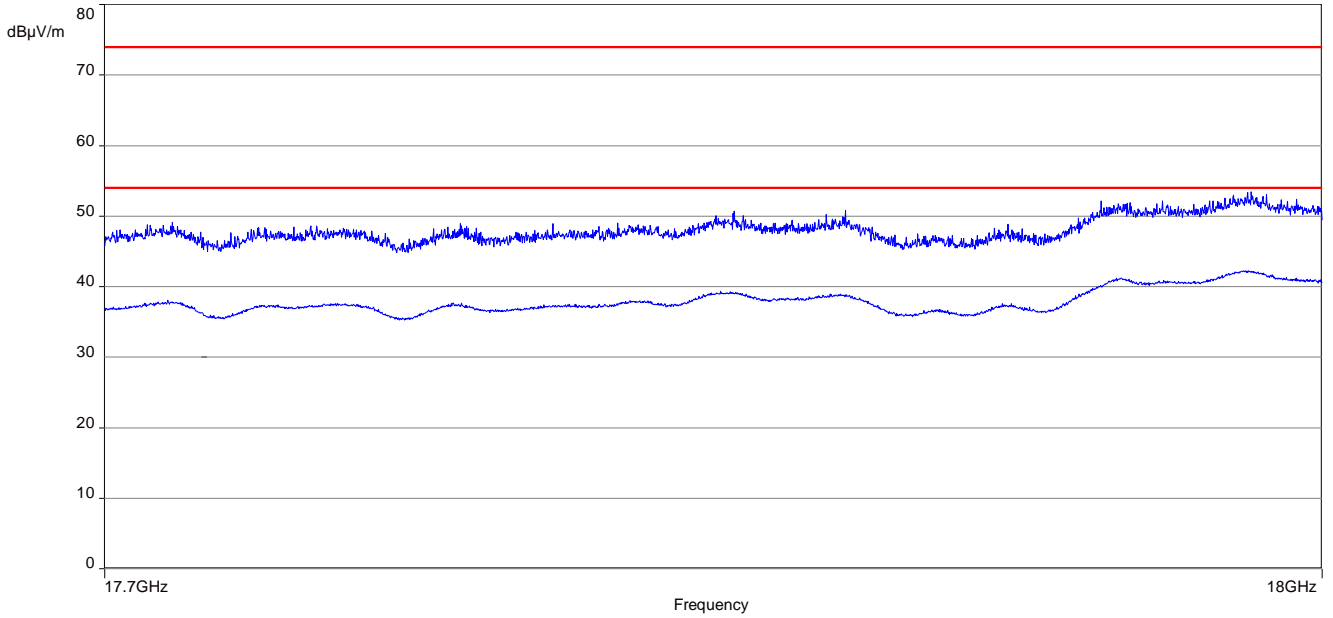

Plot 4: Lowest channel, 18 GHz to 26 GHz, vertical & horizontal polarization

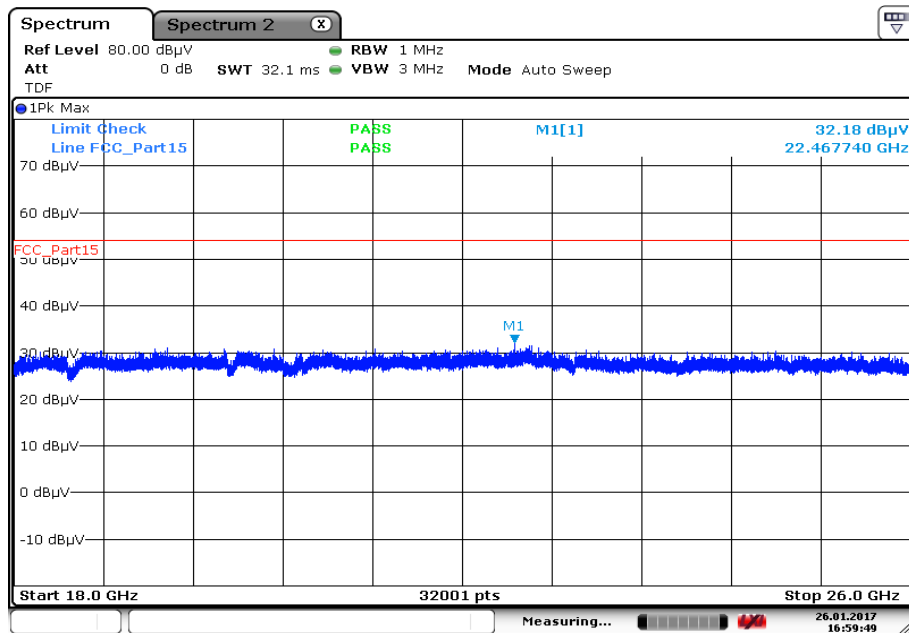

Date: 26.JAN.2017 16:59:49

Plot 5: Middle channel, 1 GHz to 7 GHz, vertical & horizontal polarization

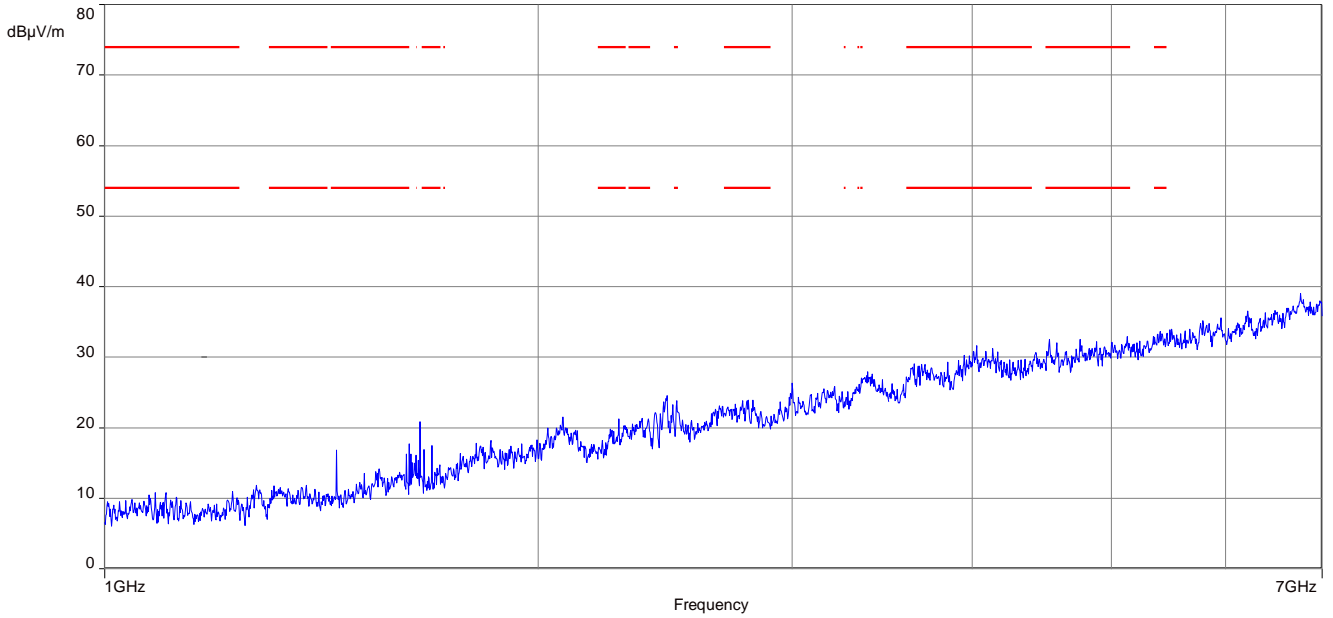

The carrier signal is notched with a 2.4 GHz band rejection filter.

Plot 6: Middle channel, 7 GHz to 18 GHz, vertical & horizontal polarization

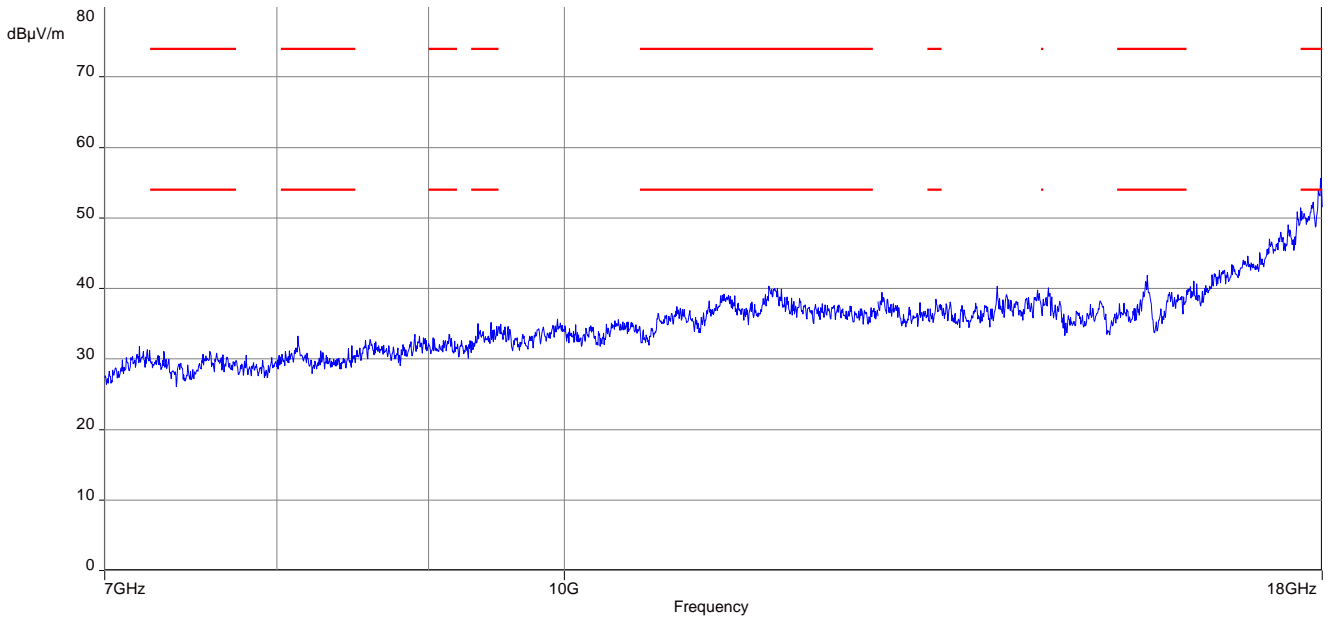

Plot 7: Middle channel, 17.7 GHz to 18 GHz, vertical & horizontal polarization

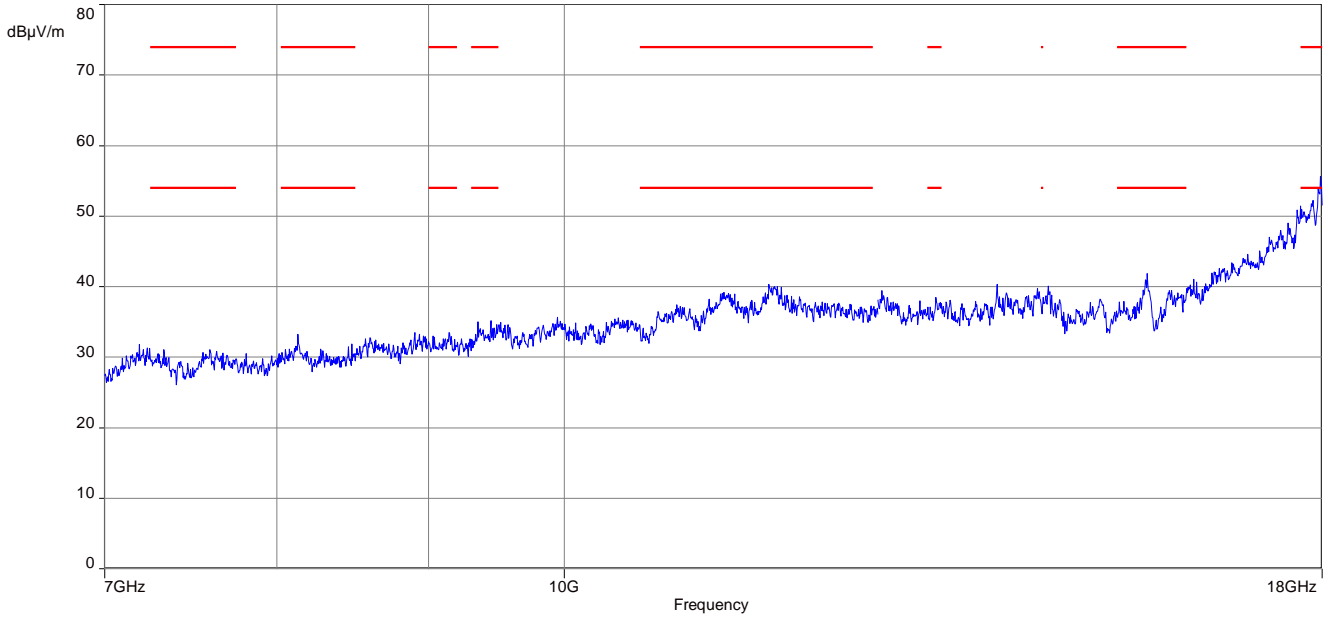

Plot 8: Middle channel, 18 GHz to 26 GHz, vertical & horizontal polarization

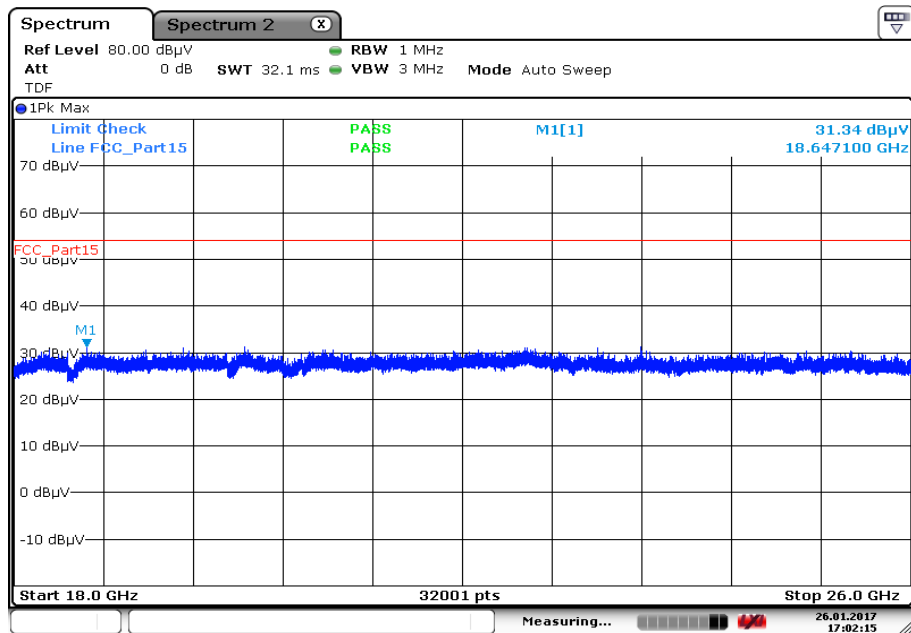

Date: 26.JAN.2017 17:02:14

Plot 9: Highest channel, 1 GHz to 7 GHz, vertical & horizontal polarization

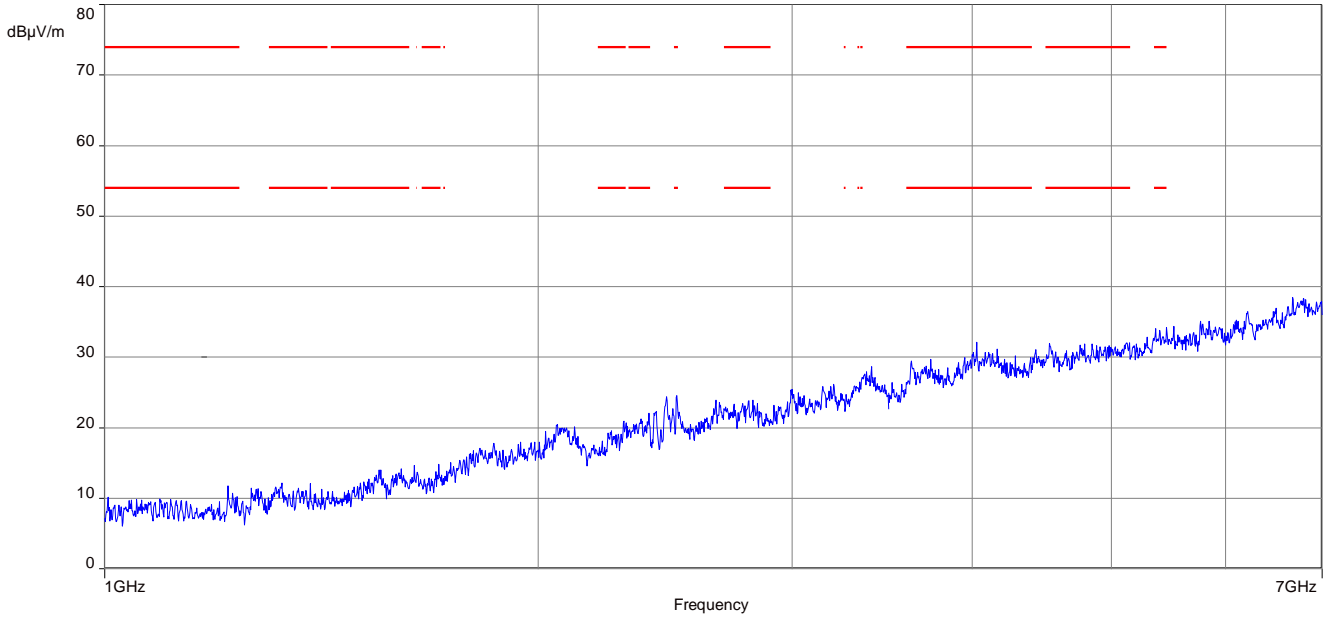

The carrier signal is notched with a 2.4 GHz band rejection filter.

Plot 10: Highest channel, 7 GHz to 18 GHz, vertical & horizontal polarization

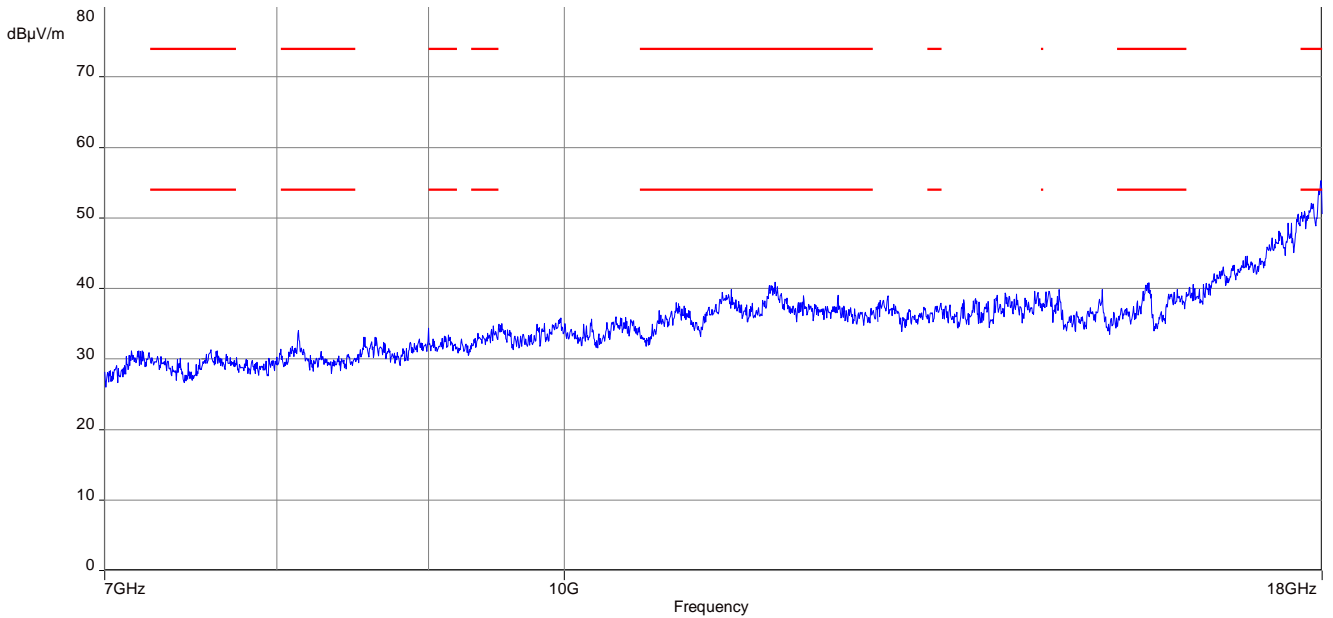

Plot 11: Highest channel, 17.7 GHz to 18 GHz, vertical & horizontal polarization

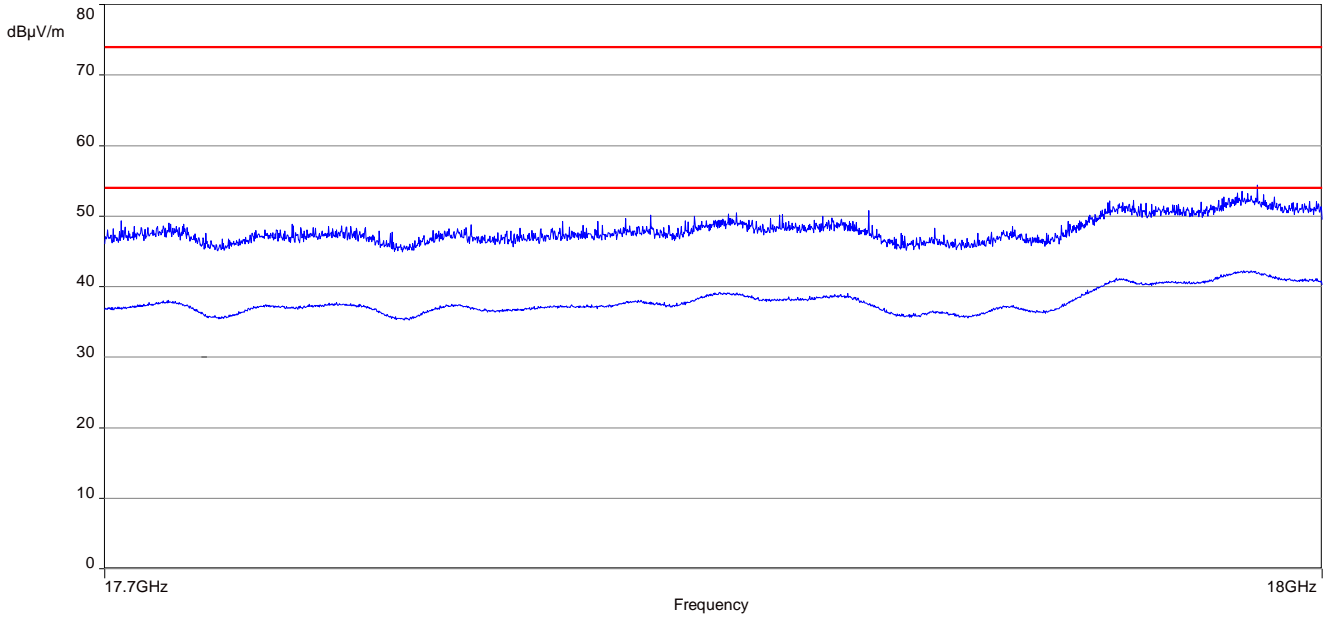

Plot 12: Highest channel, 18 GHz to 26 GHz, vertical & horizontal polarization

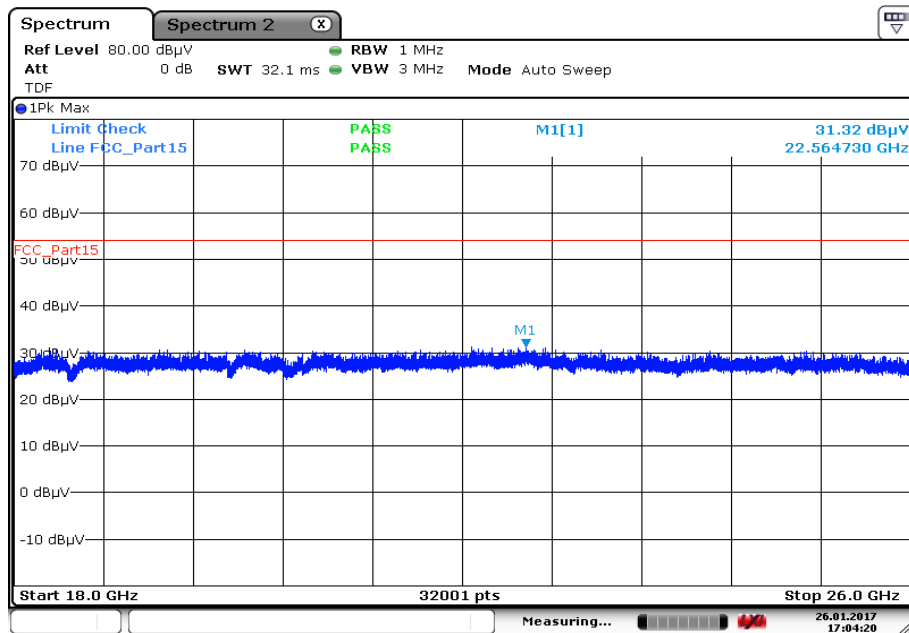

Date: 26.JAN.2017 17:04:20

Plots: OFDM (40 MHz bandwidth)

Plot 1: Lowest channel, 1 GHz to 7 GHz, vertical & horizontal polarization

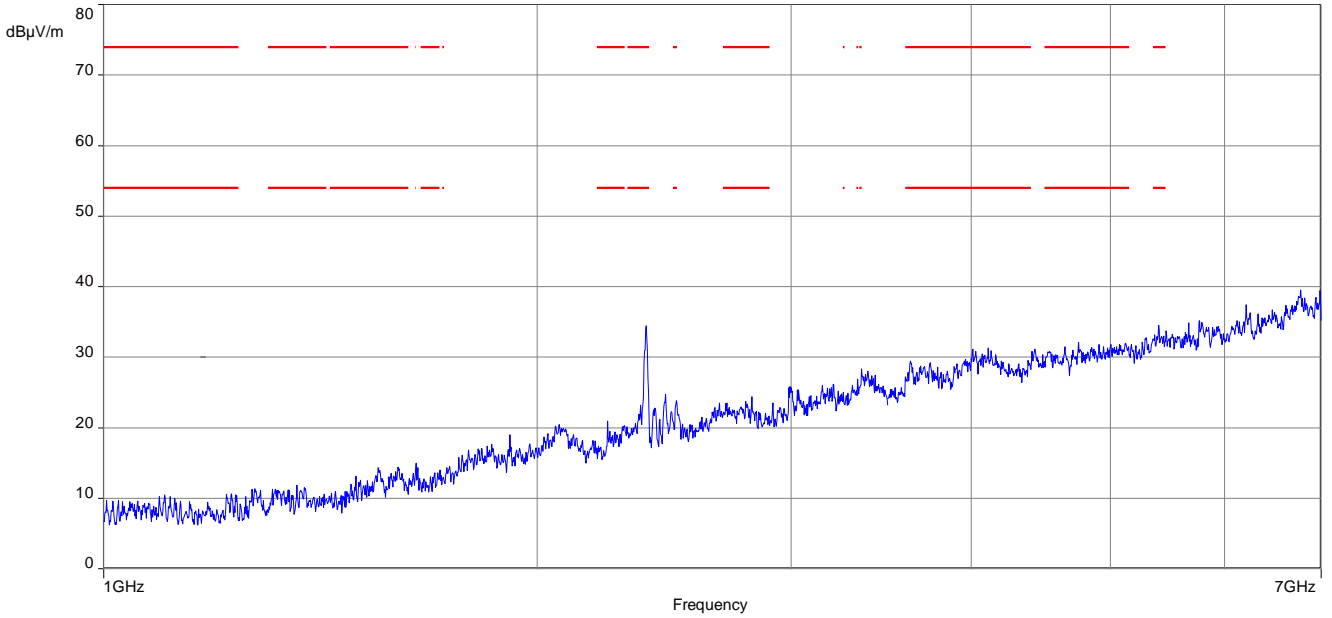

The carrier signal is notched with a 2.4 GHz band rejection filter.

Plot 2: Lowest channel, 7 GHz to 18 GHz, vertical & horizontal polarization

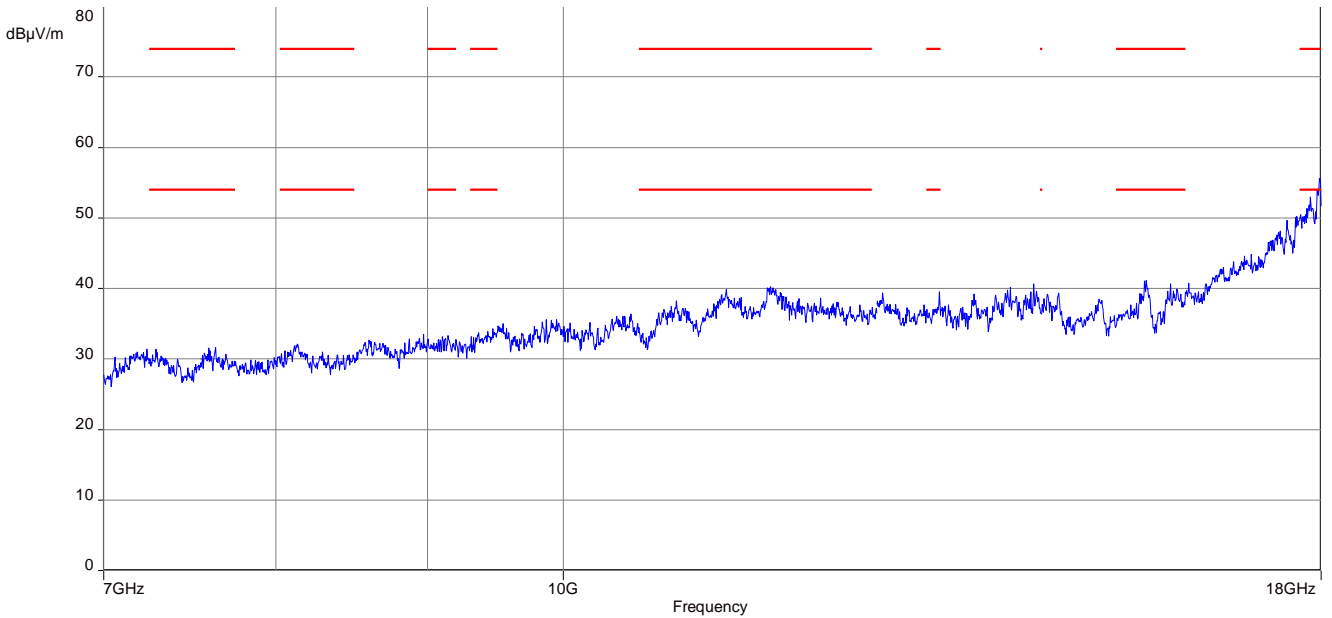

Plot 3: Lowest channel, 17.7 GHz to 18 GHz, vertical & horizontal polarization

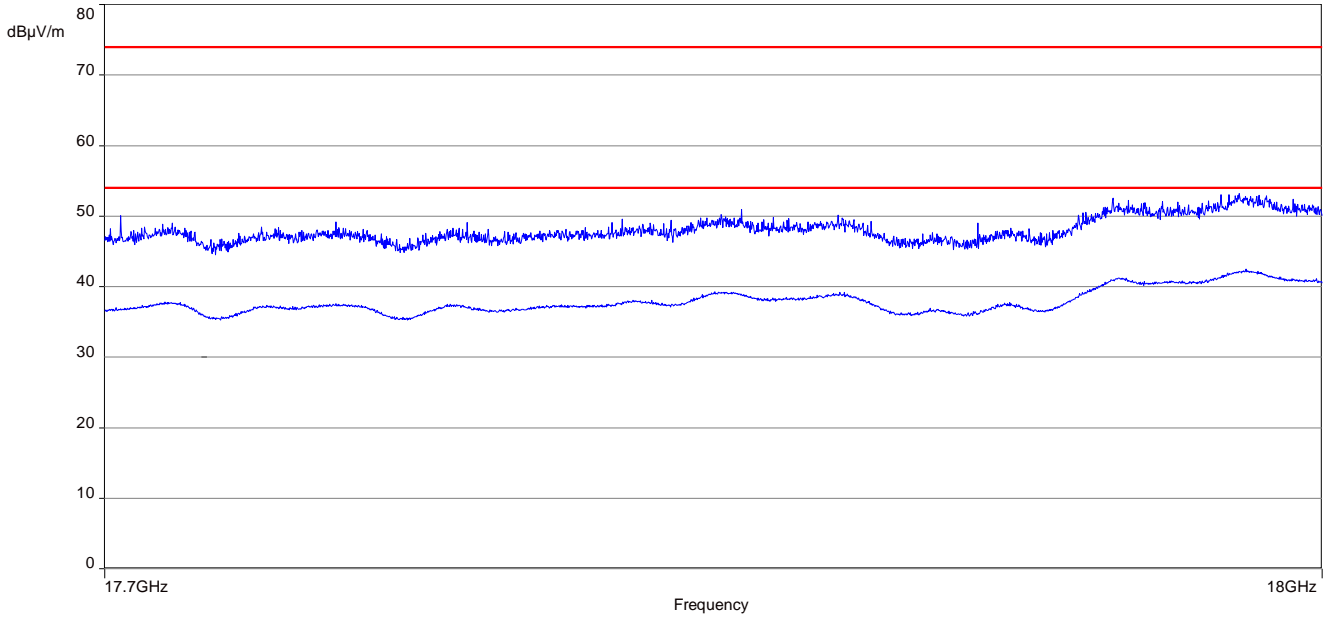

Plot 4: Lowest channel, 18 GHz to 26 GHz, vertical & horizontal polarization

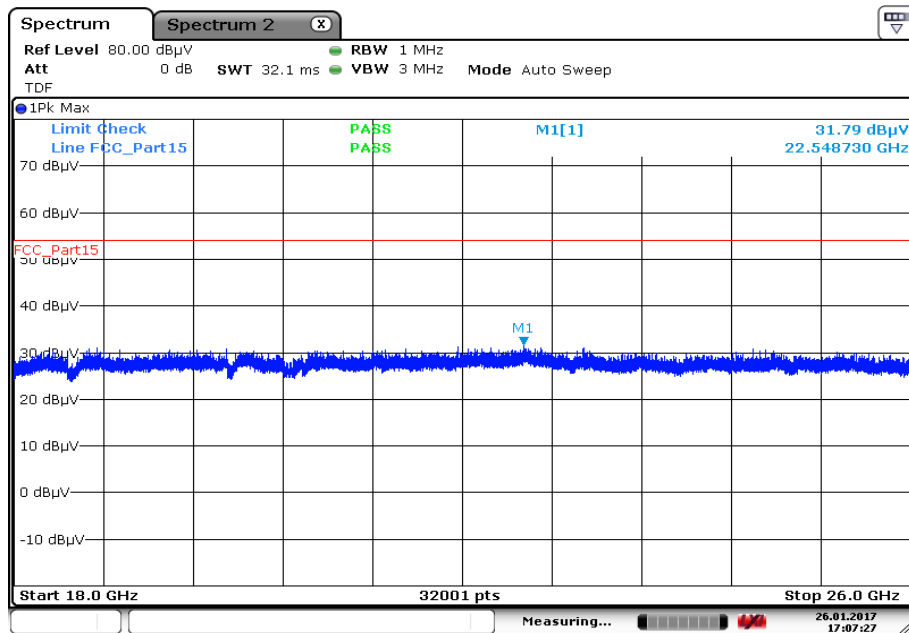

Plot 5: Middle channel, 1 GHz to 7 GHz, vertical & horizontal polarization

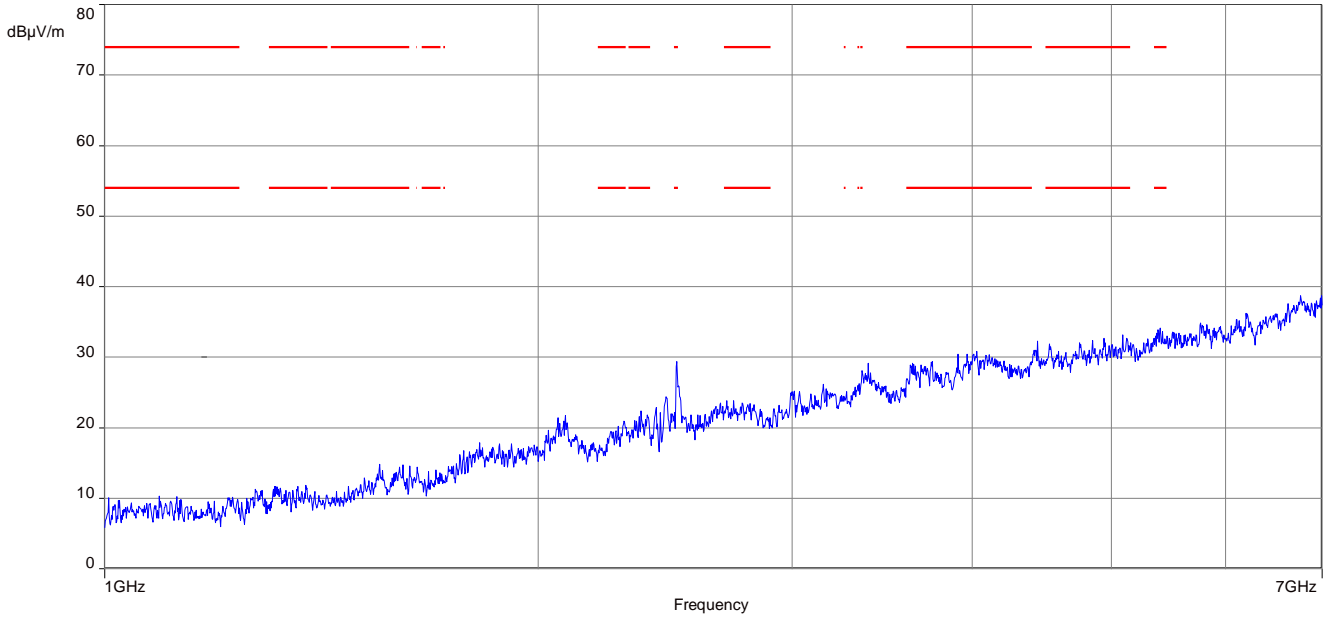

The carrier signal is notched with a 2.4 GHz band rejection filter.

Plot 6: Middle channel, 7 GHz to 18 GHz, vertical & horizontal polarization

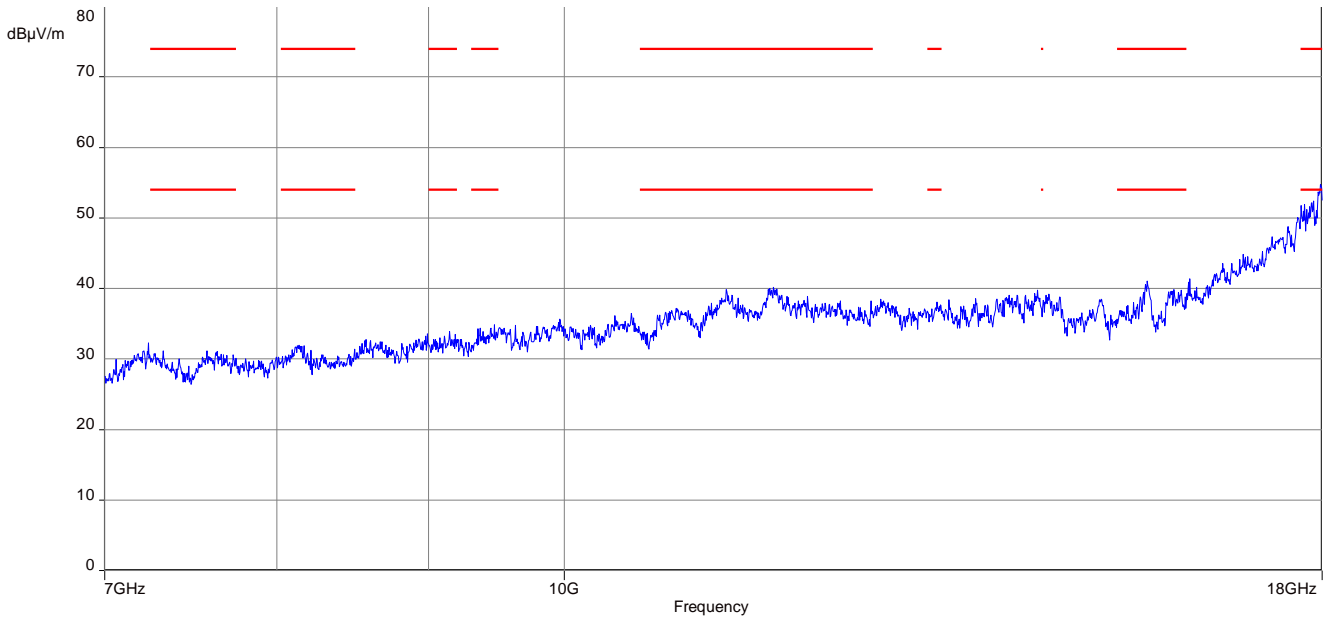

Plot 7: Middle channel, 17.7 GHz to 18 GHz, vertical & horizontal polarization

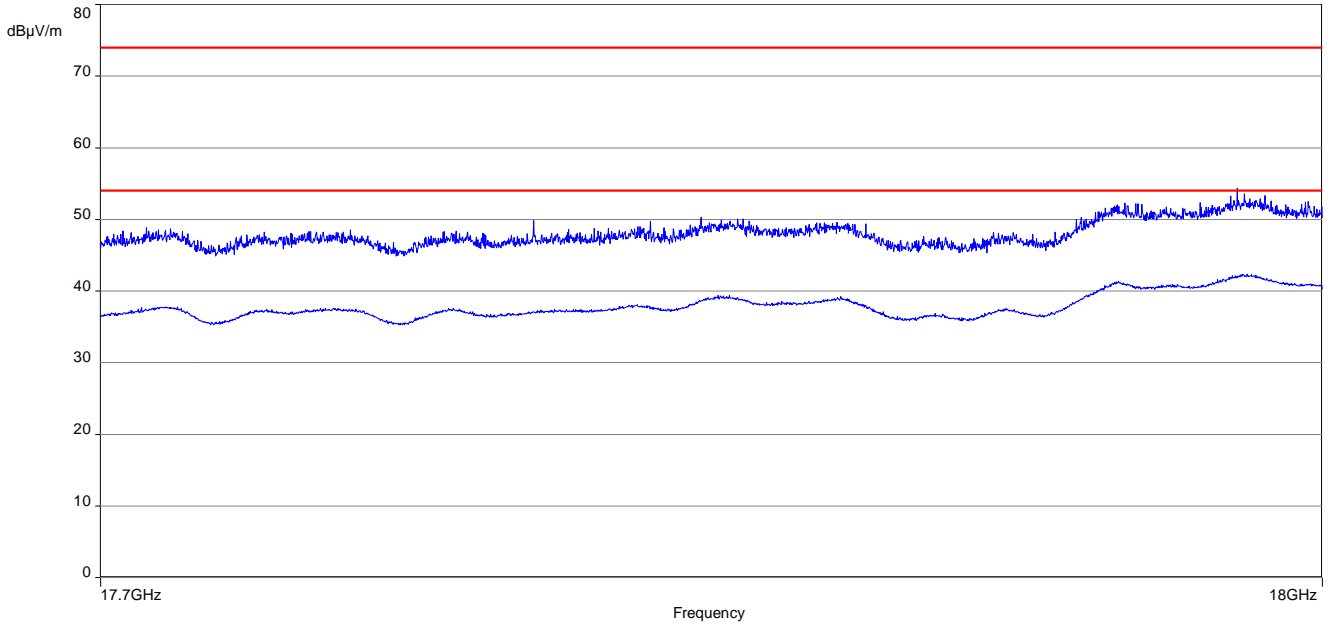

Plot 8: Middle channel, 18 GHz to 26 GHz, vertical & horizontal polarization

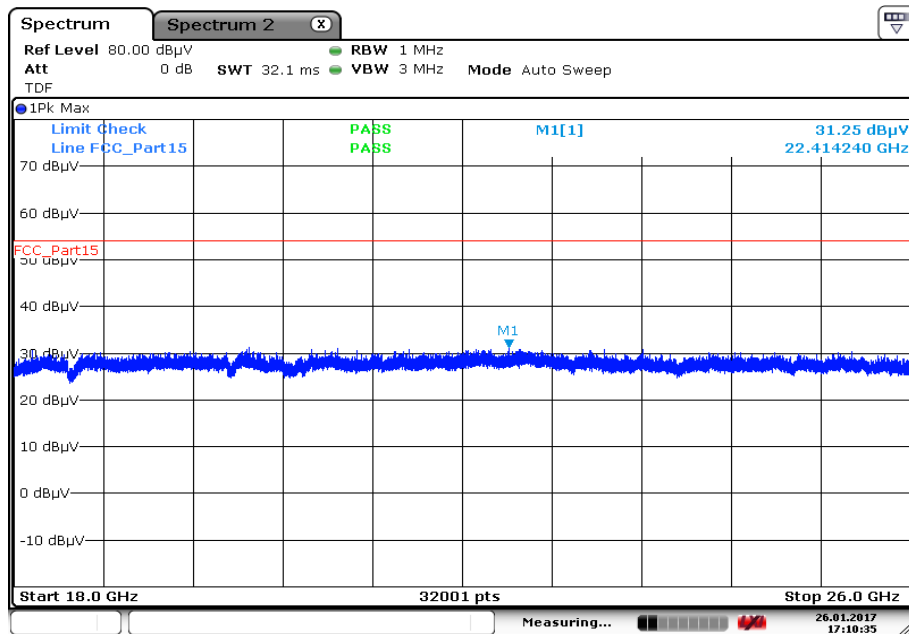

Date: 26.JAN.2017 17:10:35

Plot 9: Highest channel, 1 GHz to 7 GHz, vertical & horizontal polarization

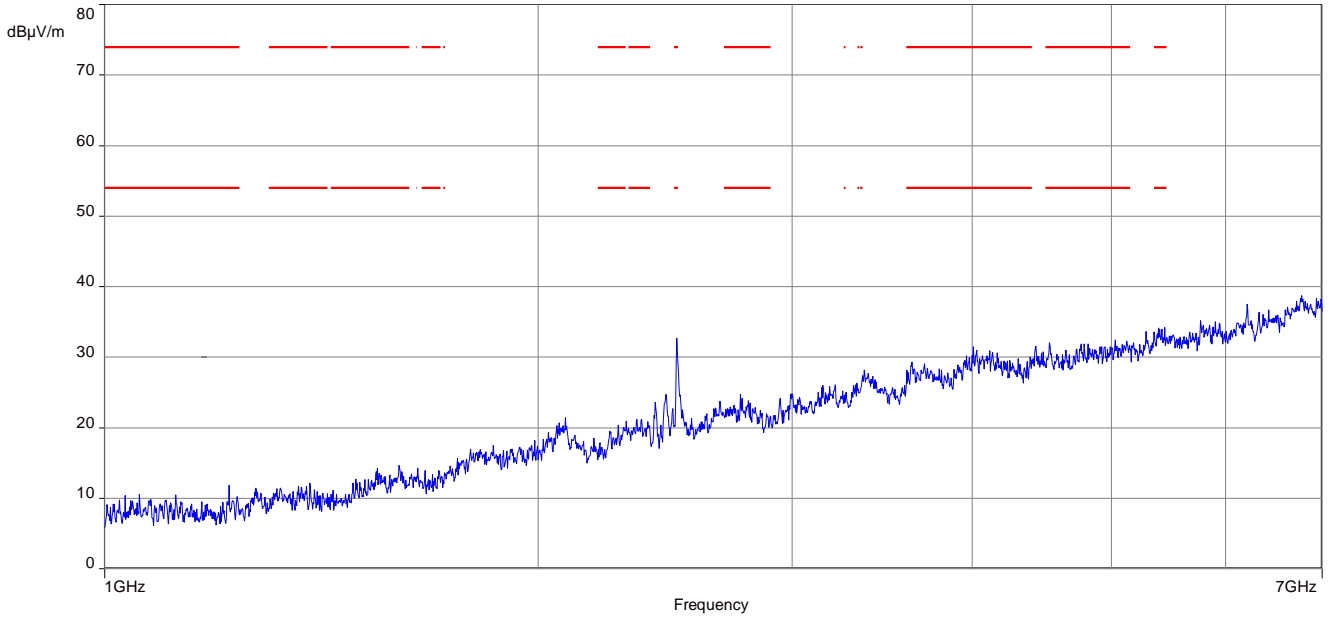

The carrier signal is notched with a 2.4 GHz band rejection filter.

Plot 10: Highest channel, 7 GHz to 18 GHz, vertical & horizontal polarization

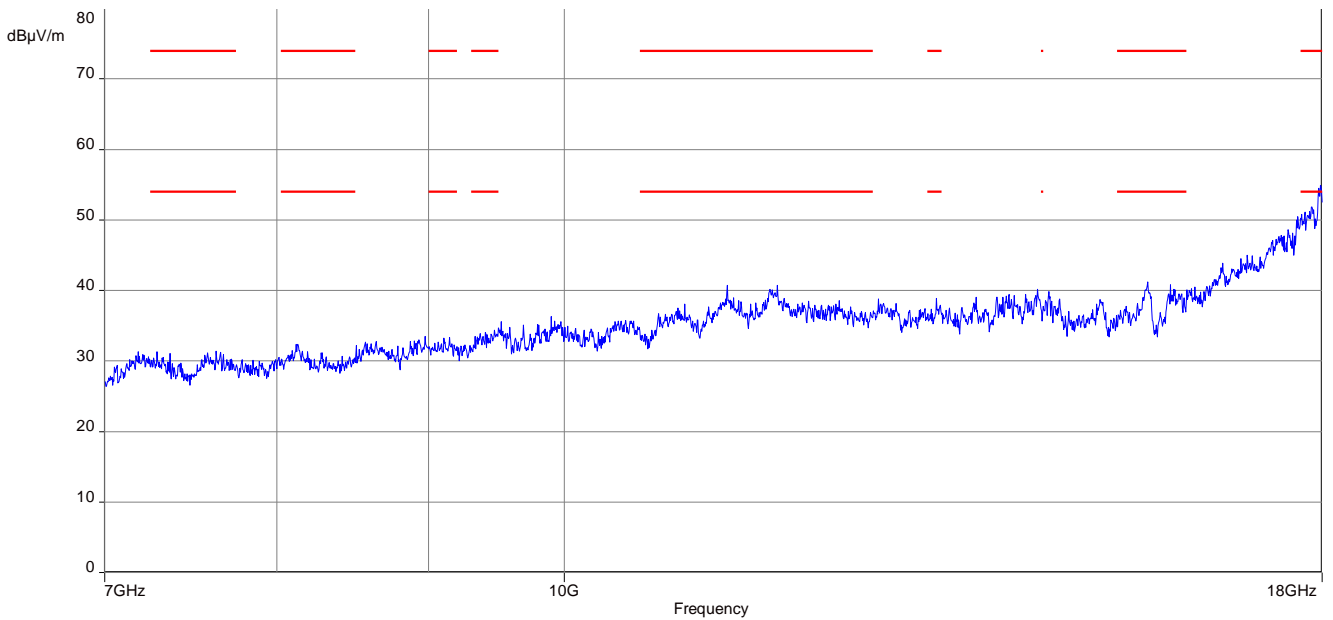

Plot 11: Highest channel, 17.7 GHz to 18 GHz, vertical & horizontal polarization

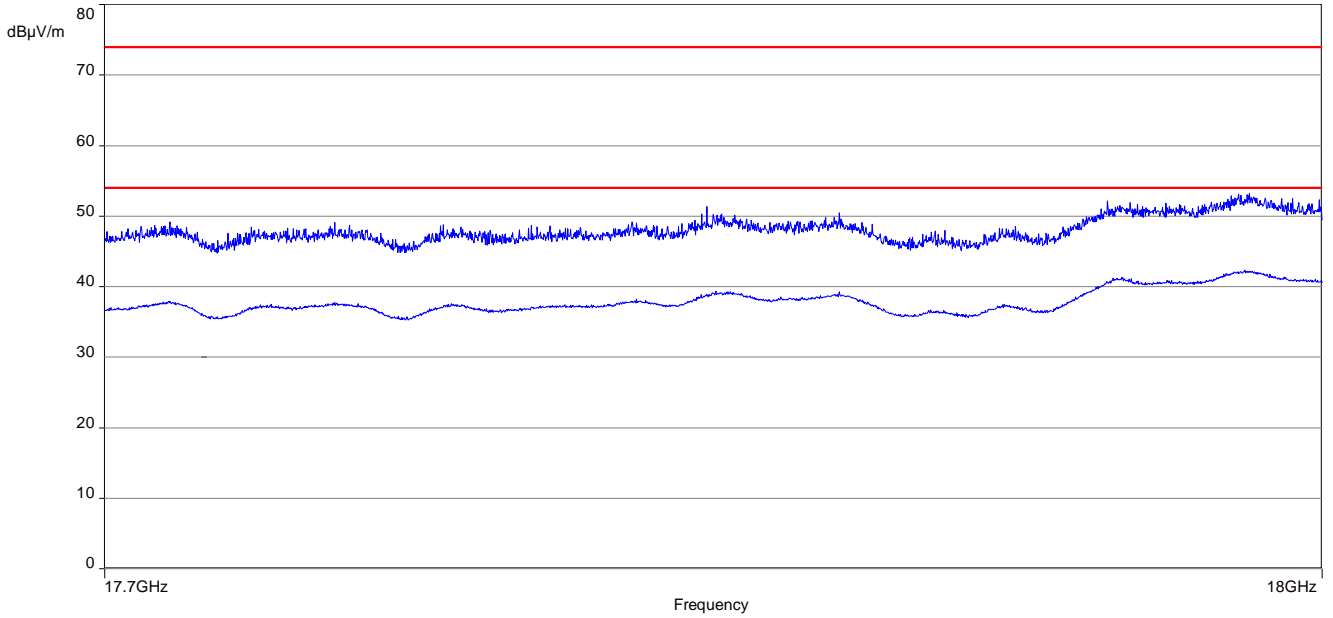

Plot 12: Highest channel, 18 GHz to 26 GHz, vertical & horizontal polarization

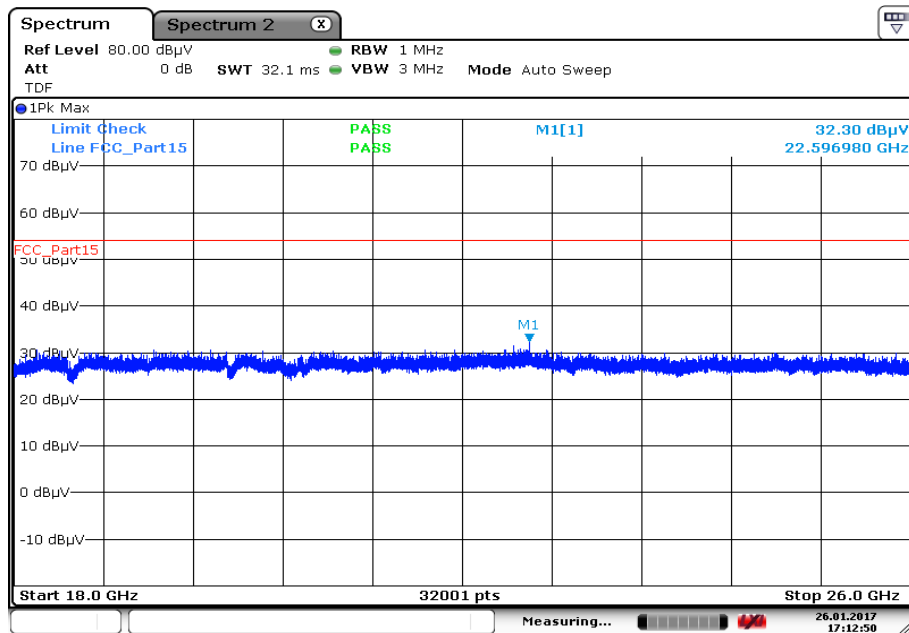

Plots: RX / idle mode

Plot 1: 1 GHz to 7 GHz, vertical & horizontal polarization

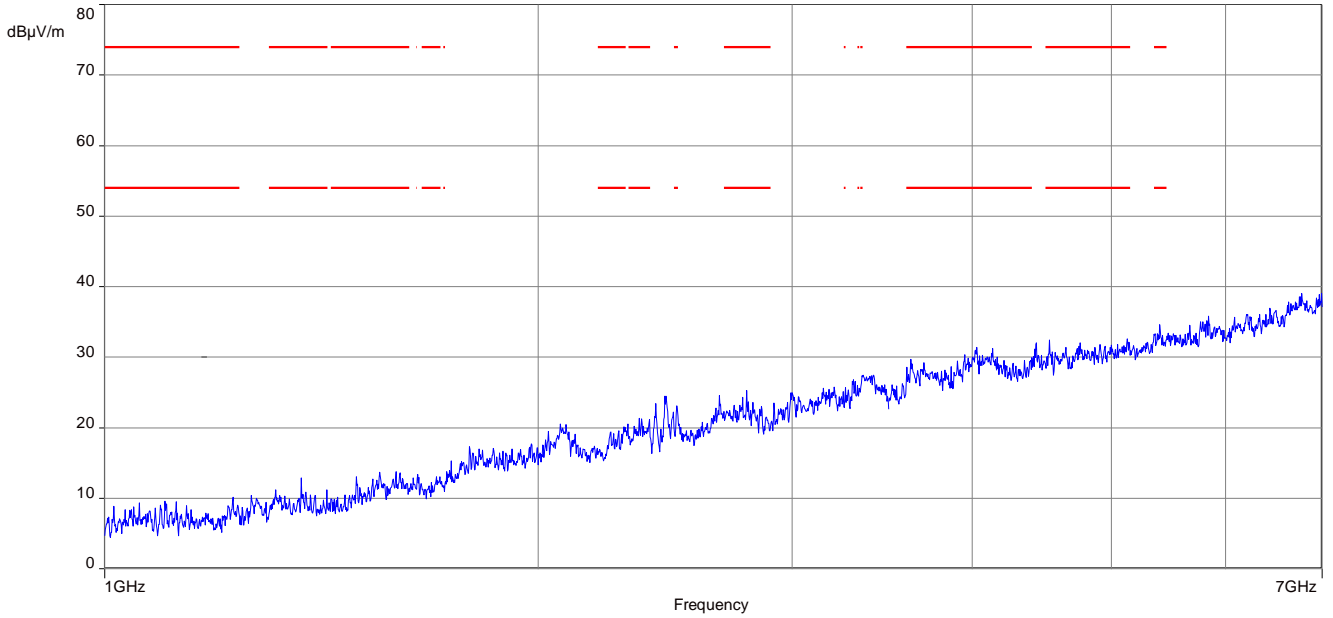

Plot 1: 7 GHz to 18 GHz, vertical & horizontal polarization

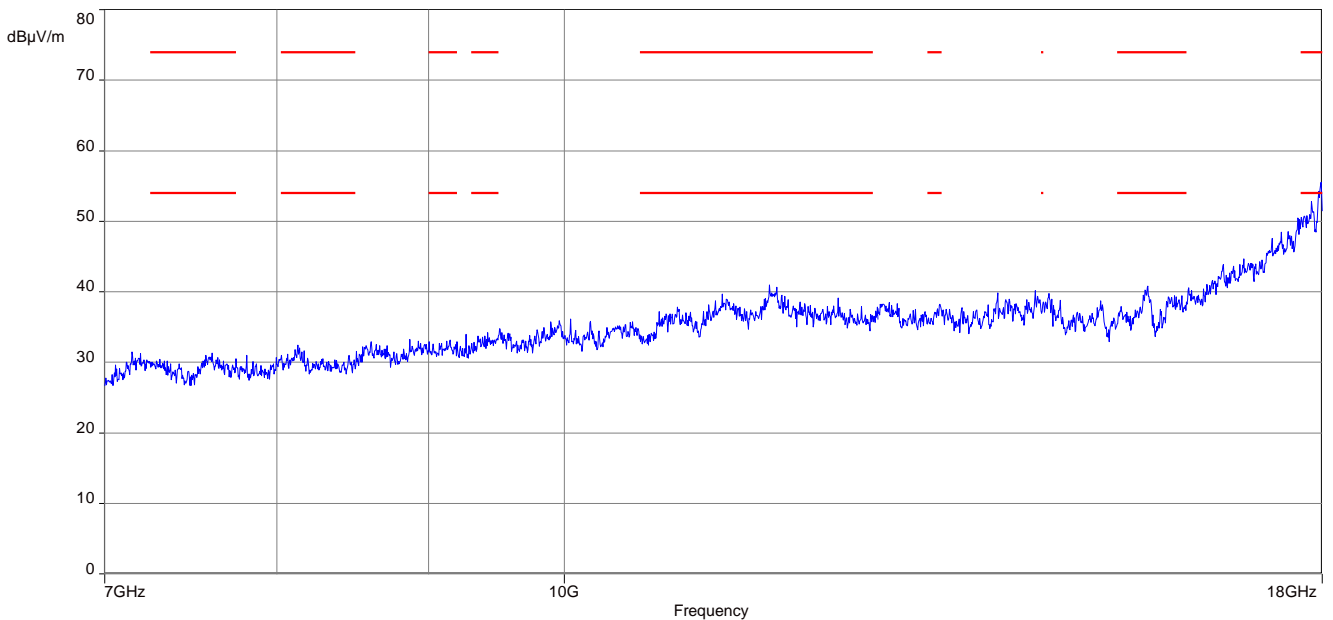

Plot 2: 17.7 GHz to 18 GHz, vertical & horizontal polarization

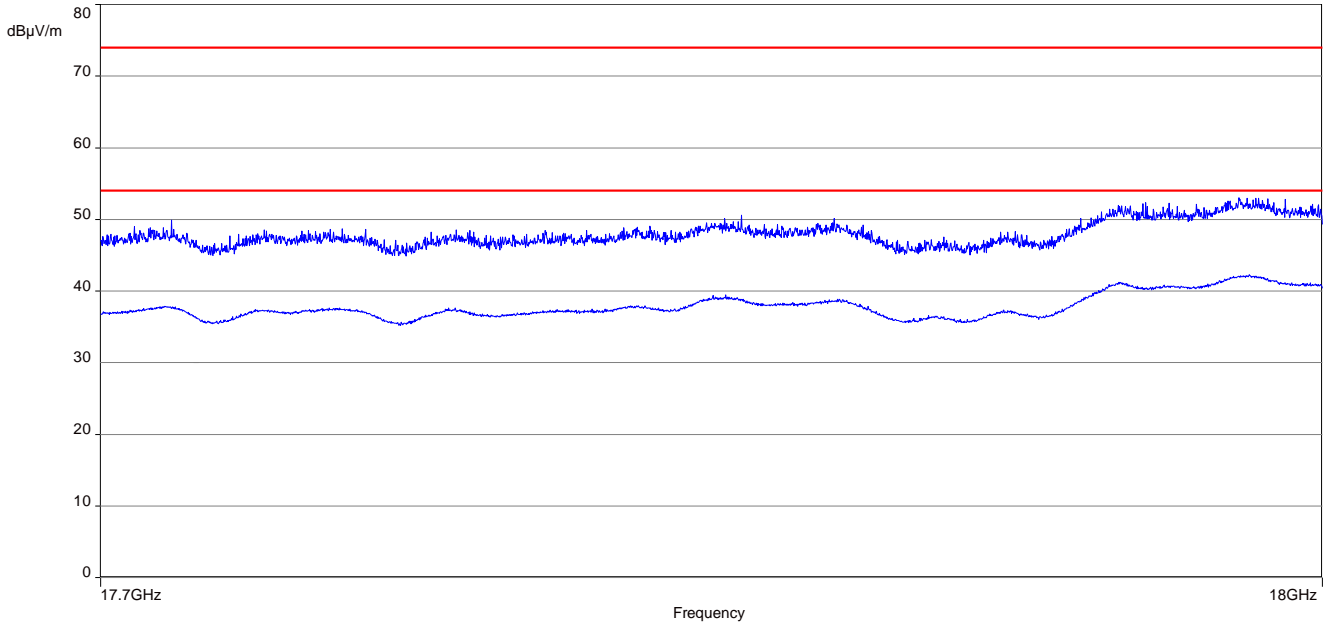

Plot 3: 18 GHz to 26 GHz, vertical & horizontal polarization

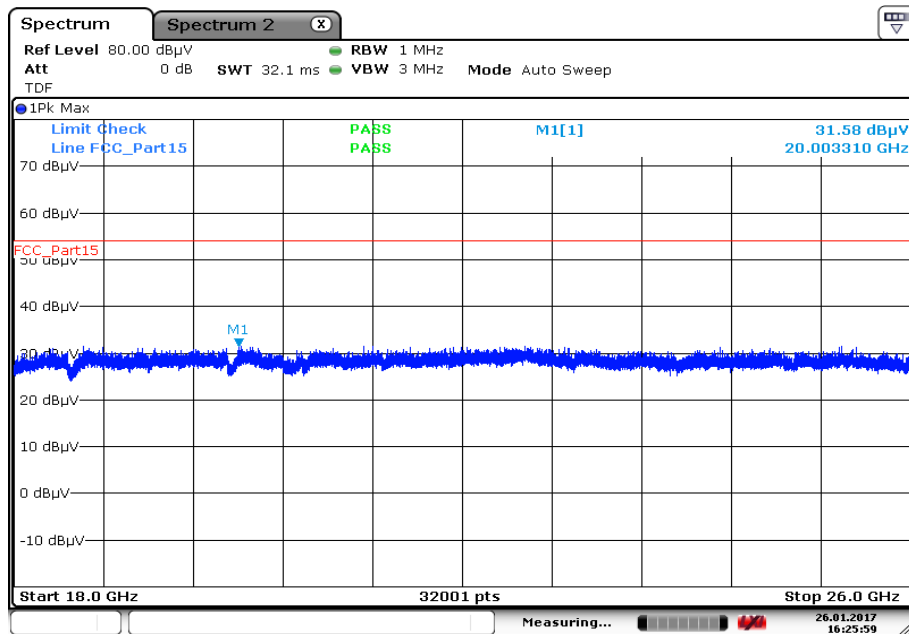

Date: 26.JAN.2017 16:25:59

12 Observations

No observations except those reported with the single test cases have been made.

Annex A Document history

Version	Applied changes	Date of release
	Initial release	2017-02-20
-A	Editorial changes	2017-04-04
-B	External antennas added	2017-04-18

Annex B Further information

Glossary

AVG	-	Average
DUT	-	Device under test
EMC	-	Electromagnetic Compatibility
EN	-	European Standard
EUT	-	Equipment under test
ETSI	-	European Telecommunications Standard Institute
FCC	-	Federal Communication Commission
FCC ID	-	Company Identifier at FCC
HW	-	Hardware
IC	-	Industry Canada
Inv. No.	-	Inventory number
N/A	-	Not applicable
PP	-	Positive peak
QP	-	Quasi peak
S/N	-	Serial number
SW	-	Software
PMN	-	Product marketing name
HMN	-	Host marketing name
HVIN	-	Hardware version identification number
FVIN	-	Firmware version identification number
OBW		Occupied Bandwidth
OC		Operating Channel
OCW		Operating Channel Bandwidth
OOB		Out Of Band

Annex C Accreditation Certificate

first page

last page



Deutsche Akkreditierungsstelle GmbH

Befehlens gemäß § 8 Absatz 1 AkkStelleG i.V.m. § 1 Absatz 1 AkkStelleGBV
 Unterzeichnerin der Multilateralen Abkommen
 von EA, ILAC und IAF zur gegenseitigen Anerkennung

Akkreditierung



Die Deutsche Akkreditierungsstelle GmbH bestätigt hiermit, dass das Prüflaboratorium

CTC advanced GmbH
 Untertürkheimer Straße 6-10, 66117 Saarbrücken

die Kompetenz nach DIN EN ISO/IEC 17025:2005 besitzt, Prüfungen in folgenden Bereichen durchzuführen:

- Funk**
- Mobilfunk (GSM / DCS) + OTA
- Elektromagnetische Verträglichkeit (EMV)
- Produktsicherheit
- SAR / EMF
- Umwelt
- Smart Card Technology
- Bluetooth®
- Automotive
- Wi-Fi-Services
- Kanadische Anforderungen
- US-Anforderungen
- Akustik
- Near Field Communication (NFC)

Die Akkreditierungsurkunde gilt nur in Verbindung mit dem Bescheid vom 25.11.2016 mit der Akkreditierungsnummer D-PL-12076-01 und ist gültig bis 17.01.2018. Sie besteht aus diesem Deckblatt, der Rückseite des Deckblatts und der folgenden Anlage mit insgesamt 63 Seiten.

Registrierungsnummer der Urkunde: D-PL-12076-01-01

Frankfurt, 25.11.2016

Ralf Eigner
 Im Auftrag Dipl.-Ing. Ralf Eigner
 Abteilungsleiter

Stelle Minister auf der Rückseite

Deutsche Akkreditierungsstelle GmbH

Standort Berlin
 Spittelmarkt 10
 10117 Berlin

Standort Frankfurt am Main
 Europa-Allee 52
 60327 Frankfurt am Main

Standort Braunschweig
 Bundesallee 100
 38116 Braunschweig

Die auszugsweise Veröffentlichung der Akkreditierungsurkunde bedarf der vorherigen schriftlichen Zustimmung der Deutsche Akkreditierungsstelle GmbH (DAkkS). Ausgenommen davon ist die separate Weiterverbreitung des Deckblatts durch die umeiltig genannte Konformitätsbewertungsstelle in unveränderter Form.

Es darf nicht der Anschein erweckt werden, dass sich die Akkreditierung auch auf Bereiche erstreckt, die über den durch die DAkkS bestätigten Akkreditierungsbereich hinausgehen.

Die Akkreditierung erfolgte gemäß des Gesetzes über die Akkreditierungsstelle (AkkStelleG) vom 31. Juli 2009 (BGBl. I S. 2625) sowie der Verordnung (EG) Nr. 765/2008 des Europäischen Parlaments und des Rates vom 9. Juli 2008 über die Vorschriften für die Akkreditierung und Marktüberwachung im Zusammenhang mit der Vermarktung von Produkten (Abt. L 218 vom 9. Juli 2008, S. 30). Die DAkkS ist Unterzeichnerin der Multilateralen Abkommen zur gegenseitigen Anerkennung der European co-operation for Accreditation (EA), des International Accreditation Forum (IAF) und der International Laboratory Accreditation Cooperation (ILAC). Die Unterzeichner dieser Abkommen erkennen ihre Akkreditierungen gegenseitig an.

Der aktuelle Stand der Mitgliedschaft kann folgenden Webseiten entnommen werden:
 EA: www.european-accreditation.org
 ILAC: www.ilac.org
 IAF: www.iaf.eu

Note:
 The current certificate including annex can be received on request.