

Recognized by the
Federal Communications Commission
Anechoic chamber registration no.: 90462 (FCC)
Anechoic chamber registration no.: IC3462C-1 (IC)
TCB ID: DE 0001



Accredited by the
German Accreditation Council
DAR-Registration Number
DAT-P-176/94-D1



Accredited Bluetooth® Test Facility (BQTF)

Test report no.	:	1-0685-01-17/08
Applicant	:	Philips Medizin Systeme Böblingen GmbH
Type	:	MMS+WLAN a/b/g Modul für Monitore
Test Standard	:	FCC Part 15.407 RSS 210 Issue 7
FCC ID	:	PQC-WLQNBV1
IC Certification No.	:	3549C-WLANBV1

Table of contents

1. ADMINISTRATIVE DATA	3
1.1. ADMINISTRATIVE DATA OF THE TEST FACILITY	3
1.1.1 Identification of the testing laboratory	3
1.1.2 Organizational items	3
1.1.3 Applicant's details	4
1.2 ADMINISTRATIVE DATA OF MANUFACTURER / MEMBER	4
1.3 DESCRIPTION OF THE EQUIPMENT UNDER TEST (EUT)	5
1.3.1 EUT: Type, S/N etc.	5
1.3.2 If RF component testing only, description of additional used HW/SW	5
1.3.4 Additional EUT information For IC Canada (appendix 2)	6
1.3.5 EUT operating modes	7
1.3.6 Extreme conditions testing values	7
2 TEST STANDARD & SUMMARY LIST OF ALL PERFORMED TEST CASES	8
3 RF MEASUREMENT TESTING	9
3.1 DESCRIPTION OF TEST SET-UP	9
3.1.1 Radiated measurements	9
3.1.2 Conducted measurements	10
3.2 REFERENCED DOCUMENTS	11
3.3 ADDITIONAL COMMENTS	11
3.4 MANUFACTURER'S DECLARATION	13
3.5 ANTENNA GAIN	13
3.6 TRANSMIT POWER §15.407A(1)+(4)	14
3.6.1 Measurement 1: 6 dB emission bandwidth of the sample	14
3.6.2 Measurement 1: 20 dB emission bandwidth of the sample	14
3.6.3 Measurement 1: 26 dB emission bandwidth of the sample	14
3.7 PEAK POWER SPECTRAL DENSITY §15.407(A5)	16
3.8 RATIO OF PEAK EXCURSION §15.407(A6)	17
3.9 UNDESIRABLE EMISSION LIMITS AT BAND EDGES 15.407 (B3)	18
3.10 SPURIOUS EMISSIONS (CONDUCTED) 15.407 (B3)	19
3.11 MPE CALCULATION	20
3.12 MAX. PEAK OUTPUT POWER RADIATED §15.247 (B) (1)	21
3.13 SPURIOUS EMISSIONS - RADIATED (TRANSMITTER) §15.209	22
3.14 SPURIOUS EMISSIONS RADIATED (RX) § 15.209	82
3.15 SPURIOUS EMISSIONS - RADIATED <30 MHZ (VALID FOR ALL ANTENNA TYPES) §15.109	89
3.16 CONDUCTED EMISSIONS <30 MHZ §15.107/207	92
3.17 TEST EQUIPMENT	93
4 PHOTOGRAPHS	97
5 PHOTOGRAPHS OF EQUIPMENT UNDER TEST	98

1. Administrative data

1.1. Administrative data of the test facility

1.1.1 Identification of the testing laboratory

Company name:	Cetecom ICT Services GmbH
Address:	Untertürkheimerstr. 6-10 D-66117 Saarbruecken Germany
Laboratory accreditation:	DAR-Registration No. DAT-P-176/94-D1 Bluetooth Qualification Test Facility (BQTF)
Responsible for testing laboratory:	Michael Berg Phone: +49 681 598 0 Fax: +49 681 598 9075 email: info@ict.cetecom.de

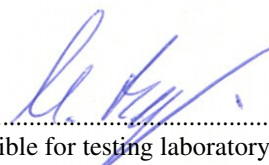

.....
Responsible for testing laboratory
(Michael Berg)

1.1.2 Organizational items

Reference No.:	1-0685-01-17/08
Order No.:	-/-
Responsible for test report and project leader:	Stefan Bös, Marco Bertolino
Receipt of EUT:	2008-10-01
Date(s) of test:	2008-10-01 to 2009-02-18
Date of report:	2009-02-19
Number of report pages:	102

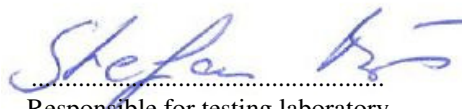
Version of template:	1.6

.....
Responsible for testing laboratory
(Stefan Bös)

.....
Responsible for test report
(Marco Bertolino)

Note:

The test results of this test report relate exclusively to the item tested as specified in this report. The CETECOM ICT Services GmbH does not assume responsibility for any conclusions and generalizations drawn from the test results with regard to other specimens or samples of the type of the equipment represented by the test item.

The test report may only be reproduced or published in full. Reproduction or publication of extracts from the report requires the prior written approval of the CETECOM ICT Services GmbH.

During the test no hardware and software changes are allowed to be performed at the EUT.

1.1.3 Applicant's details

Name:	Philips Medizin Systeme Böblingen GmbH
Street:	Hewlett-Packard-Strasse 2
Town:	71034 Böblingen
Country:	Germany
Telephone:	
Fax:	+49-7031-463 2944
Contact:	Herrn Stefan Breuer
E-mail:	stefan.breuer@philips.com
Telephone:	+49-7031-463 2321

1.2 Administrative data of manufacturer / member

Name:	Philips Medizin Systeme Böblingen GmbH
Street:	Hewlett-Packard-Strasse 2
Town:	71034 Böblingen
Country:	Germany
Telephone:	
Fax:	+49-7031-463 2944
Contact:	Herrn Stefan Breuer
E-mail:	stefan.breuer@philips.com
Telephone:	+49-7031-463 2321

1.3 Description of the Equipment under test (EUT)

1.3.1 EUT: Type, S/N etc.

Product name		Description	S/N serial number	HW hardware status	SW software status
MMS+WLAN a/b/g Modul für Monitore		Modul for healthcare monitoring systems	FH 830 000187	0839	-/-
Frequency Band [MHz]	Type of Modulation	Number of channels	Antenna	Power Supply	Temperature Range
5150 – 5250	OFDM	4	2 PCB antennas 1 rod antenna	DC by power supply 5 V / 0.5 A	-20°C to +55°C
5250 – 5350		4			
		8			

1.3.2 If RF component testing only, description of additional used HW/SW

	Product name	Product ID	Description	S/N serial number	HW hardware status	SW software status
1	--	--	--	--	--	--
2	--	--	--	--	--	--

1.3.3 Additional EUT information For IC Canada (appendix 2)

IC Certification Number:	3549C-WLANBV1
Model Name:	MMS+WLAN a/b/g Modul für Monitore
Manufacturer (complete Address):	Philips Medizinsysteme Böblingen GmbH Hewlett-Packard-Strasse 2 71034 Böblingen Germany
Tested to Radio Standards Specification (RSS) No.:	RSS-210 Issue 7
Open Area Test Site Industry Canada Number:	IC 3462C-1
Frequency Range (or fixed frequency) [MHz]:	5150 MHz – 5250 MHz 5250 MHz – 5350 MHz
RF: Power [W] (max):	OFDM: Rad. EIRP: 94.84 mW Conducted: 48.64 mW
Antenna Type:	Integrated antenna
Occupied Bandwidth (99% BW) [MHz]:	OFDM 6 dB: Not performed! OFDM 20 dB: Not performed!
Type of Modulation:	OFDM
Emission Designator (TRC-43):	Not performed!
Transmitter Spurious (worst case) [μ V/m in 1m]:	63.90
Receiver Spurious (worst case) [μ V/m in 3m]:	Noise floor

ATTESTATION:

I attest that the testing was performed or supervised by me; that the test measurements were made in accordance with the above-mentioned departmental standard(s), and that the radio equipment identified in this application has been subject to all applicable test conditions specified in the departmental standards and all of the requirements of the standards have been met.

Signature:

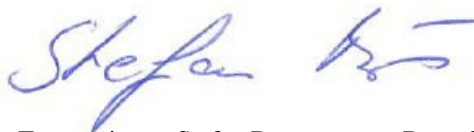

Test engineer: Stefan Bös

Date: 2009-02-19

Signature:



Test engineer: Marco Bertolino

Date: 2009-02-19

1.3.4 EUT operating modes

EUT operating mode no.*)	Description of operating modes	Additional information
Op. 0	normal mode	normal temperature and power source conditions
Op. 1		low temperature, low power source conditions
Op. 3		low temperature, high power source conditions
Op. 4		high temperature, low power source conditions
Op. 5		high temperature, high power source conditions

*) EUT operating mode no. is used to simplify the test report.

1.3.5 Extreme conditions testing values

Description	Shortcut	Unit	Value
Nominal Temperature	T_{nom}	°C	20
Nominal Humidity	H_{nom}	%	54
Nominal Power Source	V_{nom}	V	5 V / 500 mA DC

Type of power source: **DC by power supply**

Deviations from these values are reported in chapter 2

2 Test standard & summary list of all performed test cases

- No deviations from the technical specifications were ascertained**
- There were deviations from the technical specifications ascertained

TC identifier	Description	verdict	date	Remark
RF-Testing	FCC Part 15 §15.247 - CANADA RSS-210	passed	2009-02-19	-/-

Test Specification Clause	Test Case	Pass	Fail	Not applicable	Not performed
Range:	5.150 to 5.250 GHz				
None	Antenna Gain	Yes			
§15.407a(3)+(4)	Peak transmit power	Yes			
§15.407	Emission bandwidth (6 dB, 20 dB, 26 dB)				Yes
§15.407a(5)	Peak power spectral density conducted				Yes
§ 15.407a (6)	Ratio of peak excursion				Yes
§ 15.407b (3)	Undesirable emissions conducted				Yes
§ 15.209	Spurious Emission -radiated (TX)	Yes			
§ 15.209	Spurious Emission -radiated (RX)	Yes			
§ 15.107/207	Conducted Emissions <30 MHz				Yes

For more information about the conducted measurements – please take a look at the main test report.
 Report No.: 1-0685-01-07/08

3 RF measurement testing

3.1 Description of test set-up

3.1.1 Radiated measurements

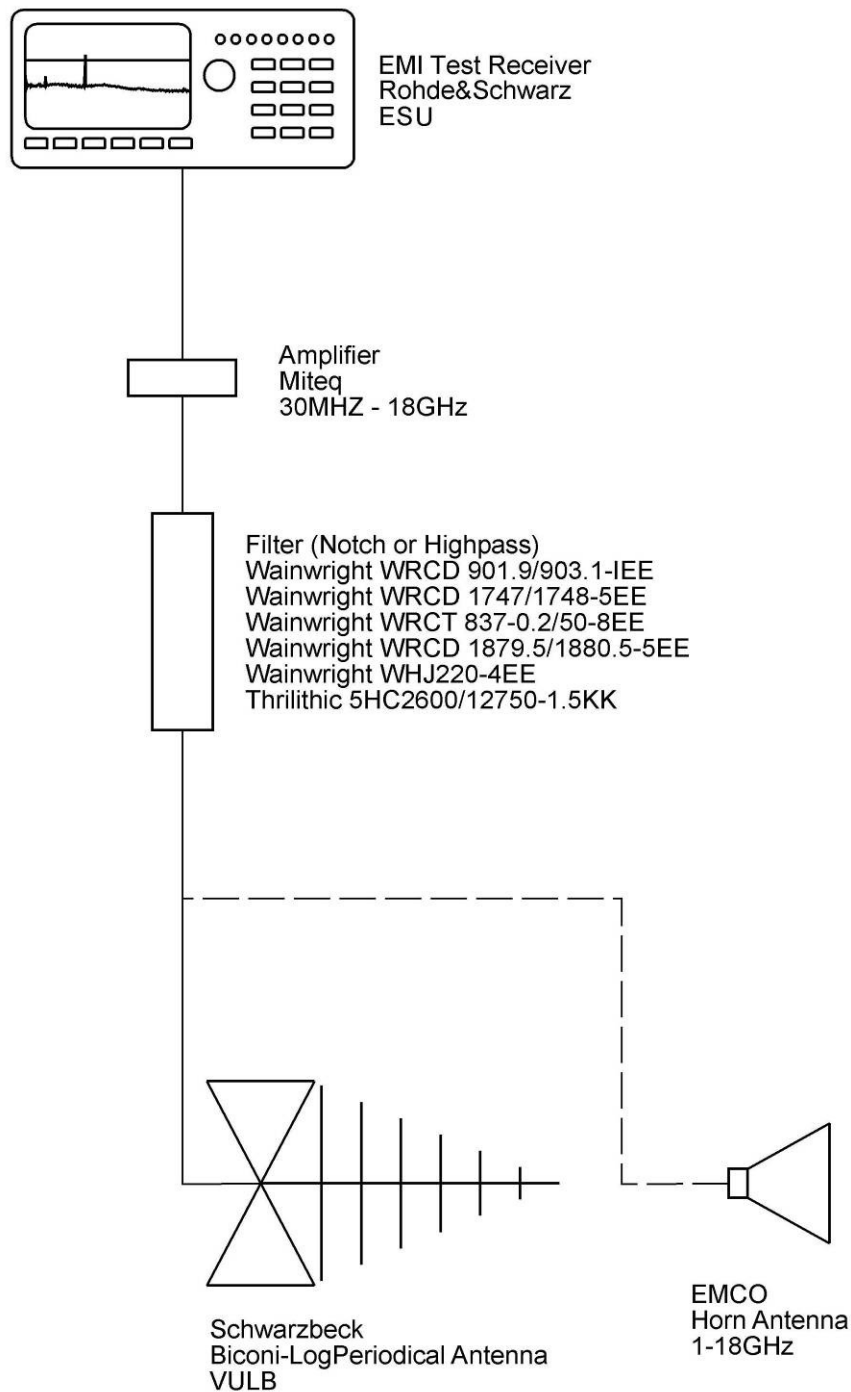

3.1.2 Conducted measurements

The EUT's RF signal is coupled out by the antenna connector which is supplied by the manufacturer. The signal is connected to the spectrum analyzer. The specific losses for signal path are first checked within a calibration. The measurement readings on the spectrum analyzer are corrected by the specific test set-up loss. The attenuator, power divider, signalling unit and the spectrum analyzer are impedance matched on 50 Ohm.

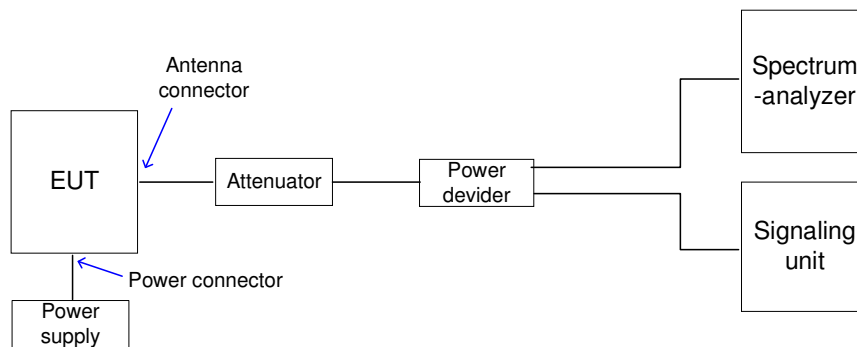

3.2 Referenced Documents

Main test report No.: 1-0685-01-07/08

3.3 Additional comments

The followings power settings are declared by the manufacture. All measurements are performed with the specified settings.

target power file for AR6000 802.11a/b/g with super a/g TB111 Reference Design card

11a Target Power table:

Rules:

- # 1. up to a maximum of 8 test frequencies
- # 2. test frequencies DO NOT need to cover the entire range of 5180-5850. It is allowed to provide data for a smaller range. for all channels outside of test frequencies range, target power will be assumed 0dB.
- # 3. specify mask/PER limited target power for various rates

#BEGIN_11a_TARGET_POWER_TABLE

# test_frequencies	6-24_target	36_target	48_target	54_target
5180	15	15	15	15
5240	15	15	15	15
5320	15	15	15	15
5440	15	15	15	15
5460	15	15	15	15
5500	15	15	15	15
5700	15	15	15	15
5745	15	15	15	15

#END_11a_TARGET_POWER_TABLE

11b Target Power table:

Rules:

- # 1. Need to define exactly 2 test frequencies in 2.412 - 2.484 G range.
- # 2. test frequencies DO NOT need to cover the entire range of 2412-2484. It is allowed to provide data for a smaller range. for all channels outside of test frequencies range, target power will be assumed 0dB.
- # 3. specify mask/PER limited target power for various rates

#BEGIN_11b_TARGET_POWER_TABLE

# test_frequencies	1_target	2_target	5.5_target	11_target
2412	15	15	15	15
2484	15	15	15	15

#END_11b_TARGET_POWER_TABLE

ofdm@2p4 Target Power table:

Rules:

- # 1. up to a maximum of 3 test frequencies in 2.412 - 2.484 G range
- # 2. test frequencies DO NOT need to cover the entire range of 2412-2484. It is allowed to provide data for a smaller range. for all channels outside of test frequencies range, target power will be assumed 0dB.
- # 3. specify mask/PER limited target power for various rates

SRD-Testreport

CETECOM ICT Services GmbH Saarbruecken, Germany



Test report No.: 1-0685-01-17/08

Date: 2009-02-19

Page 12 of 102

```
#
#BEGIN_11g_TARGET_POWER_TABLE
# test_frequencies 6-24_target 36_target 48_target 54_target
  2412           15      15      15      15
  2437           15      15      15      15
  2472           15      15      15      15
#END_11g_TARGET_POWER_TABLE

# Test Groups:
#   Rules:
#       1. Specify up to 8 band edges for each test group.
#       2. If no backoff desired at a band edge, give a large number (e.g, 30) so
#          that the driver determined limit becomes the target power.
#

#BEGIN_TEST_GROUPS

# Test Group 1: US and CANADA (FCC)
#   test_group_code BE1  BE2  BE3  BE4  BE5  BE6  BE7  BE8
  0x10             5180  5200  5260  5320  5500  5520  5700  5745
                   11   11   15   15   17   17   17   17 # Band Edge Max Power
                   0   1   1   0   0   1   0   1 # in-band flag

# Test Group 3: US and CANADA (FCC) 802.11b mode CTL
#   test_group_code BE1  BE2  BE3
  0x11             2412  2437  2442
                   17   18   17 # Band Edge Max Power
                   1   0   1 # in-band flag

# Test Group 4: US and CANADA (FCC) 802.11g mode CTL
#   test_group_code BE1  BE2  BE3  BE4
  0x12             2412  2417  2457  2462
                   16   18   18   17 # Band Edge Max Power
                   0   1   0   0 # in-band flag

# Test Group 6: JAPAN (MKK)
#   test_group_code BE1  BE2
  0x40             5170  5230
                   17   17 # Band Edge Max Power
                   0   0 # in-band flag

# Test Group 7: EUROPE (ETSI)
#   test_group_code BE1  BE2  BE3  BE4  BE5  BE6  BE7
  0x30             5180  5320  5500  5700  5745  5765  5825
                   17   17   17   17   17   17   17 # Band Edge Max Power
                   0   0   0   0   0   1   0 # in-band flag

# Test Group 8: EUROPE (ETSI) 802.11b mode CTL
#   test_group_code BE1  BE2  BE3
  0x31             2412  2417  2472
                   16   16   16 # Band Edge Max Power
                   0   1   0 # in-band flag

#END_TEST_GROUPS
```

3.4 Manufacturer's Declaration

The manufacturer attests that the power settings used for testing are part of the firmware and cannot be changed by the user or host. These settings are specific for different countries and are related to the local requirements. The following measurements were performed with the specific power settings fulfilling the requirements of the FCC- and IC- rules.

3.5 Antenna gain

The antenna gain of the complete system is calculated by the difference of radiated power in EIRP and the conducted power of the module.

	low channel (36) 5180 MHz	mid channel (40) 5200 MHz	high channel (48) 5240 MHz
Conducted power [dBm]	12.73	12.58	12.64
Radiated power [dBm]	14.00	13.86	15.17
Gain [dBi]	1.27	1.28	2.53

	low channel (52) 5260 MHz	mid channel (56) 5280 MHz	high channel (64) 5320 MHz
Conducted power [dBm]	16.23	16.71	16.87
Radiated power [dBm]	18.51	18.59	19.77
Gain [dBi]	2.28	1.88	2.90

The maximum antenna gain is below 6 dBi.

Limits:

Under normal test conditions only	max. 6 dBi
-----------------------------------	------------

3.6 Transmit Power

§15.407a(1)+(4)

3.6.1 Measurement 1: 6 dB emission bandwidth of the sample

Not performed!

Plot 1:

Plot 2:

Plot 3:

Results:

Frequency (MHz)	6 dB BW (MHz)
	--
	--
	--

3.6.2 Measurement 1: 20 dB emission bandwidth of the sample

Not performed!

Plot 1:

Plot 2:

Plot 3:

Results:

Frequency (MHz)	20 dB BW (MHz)
	--
	--
	--

3.6.3 Measurement 1: 26 dB emission bandwidth of the sample

Not performed!

Plot 1:

Plot 2:

Plot 3:

Results:

Frequency (MHz)	26 dB BW (MHz)
	--
	--
	--

Measurement 2: Peak conducted transmit output power

Not performed!

Measured with the spectrum analyzer's band power measurement according to the guidelines of the FCC public notice DA 02-2138 - method #3:

- Set span to encompass the entire emission bandwidth (EBW) of the signal
- Set sweep trigger to "free run"
- Set RBW = 1 MHz. Set VBW \geq 1/T
- Use linear display mode
- Use sample detector mode if bin width (i.e., span/number of points in spectrum) < 0.5 RBW. Otherwise use peak detector mode
- Set max hold
- Allow max hold to run for 60 seconds
- Compute power by integrating the spectrum across the 26 dB EBW or apply a bandwidth correction factor of $10 \cdot \log(\text{EBW}/1 \text{ MHz})$ to the spectral peak of the emission. The integration can be performed using the spectrum analyzer's band power measurement function with band limits set to the EBW band edges or by summing power levels in each 1 MHz band in linear power terms. The 1 MHz band power levels to be summed can be obtained by averaging, in linear power terms, power levels in each frequency bin across the 1 MHz.

Plot 1:

Plot 2:

Plot 3:

Results: Plot 1: Peak transmit power: mW / dBm
Plot 2: Peak transmit power: mW / dBm
Plot 3: Peak transmit power: mW / dBm

Limits:

Under normal test conditions only	For the band 5.15-5.25 GHz, the maximum conducted output power over the frequency band of operation shall not exceed the lesser of 50 mW or $4 \text{ dBm} + 10 \log B$, where B is the 26dB-emission bandwidth in MHz. If transmitting antennas if directional gain greater than 6 dBi are used, the maximum conducted output power shall be reduced by the amount in dB that the gain of the antenna exceeds 6 dBi.
-----------------------------------	--

3.7 Peak power spectral density

§15.407(a5)

Not performed!

Measured according to the guidelines of the FCC public notice DA 02-2138 - method #1:

- Use peak detector and max hold
- Set RBW = 1 MHz. Set VBW > 1 MHz
- The PPSD is the highest level found across the emission in any 1 MHz band.

Plot 1:

Plot 2:

Plot 3:

Results:

Test conditions	Spectral density
Frequency [MHz]	1 MHz BW
	--dBm
	--dBm
	--dBm

Limits:

Under normal test conditions only	For the band 5.15-5.25 GHz, the peak power spectral density shall not exceed 4 dBm in any 1 MHz-band. If transmitting antennas if directional gain greater than 6 dBi are used, the peak power spectral density shall be reduced by the amount in dB that the gain of the antenna exceeds 6 dBi.
-----------------------------------	--

3.8 Ratio of Peak Excursion

§15.407(a6)

Not performed!

Measured according to the guidelines of the FCC public notice DA 02-2138.

Plot 1:

Plot 2:

Plot 3:

Results:

Frequency	Ratio of peak excursion of the modulation envelope		
	Limit	Ratio(dB)	passed/fail
	< 13 dB	--	--
	< 13 dB	--	--
	< 13 dB	--	--
Measurement uncertainty	±1dB		

Limits:

Under normal test conditions only	The ratio of peak excursion of the modulation envelope (measured using a peak hold function) to the maximum conducted output power shall not exceed 13 dB across any 1 MHz bandwidth or the emission bandwidth whichever is less.
-----------------------------------	---

3.9 Undesirable emission limits at band edges

15.407 (b3)

Not performed!

Plot 1: lower band edge

Plot 2: upper band edge

Limits:

Under normal test conditions only	The ratio of peak excursion of the modulation envelope (measured using a peak hold function) to the maximum conducted output power shall not exceed 13 dB across any 1 MHz bandwidth or the emission bandwidth whichever is less.
-----------------------------------	---

3.10 Spurious emissions (conducted)

15.407 (b3)

Not performed!

- Plot 1:
- Plot 2:
- Plot 3:
- Plot 4:
- Plot 5:
- Plot 6:
- Plot 7:
- Plot 8:
- Plot 9:
- Plot 10:
- Plot 11:
- Plot 12:

Spurious emissions (conducted)

Result & Limits

Emission Limitations					
f [MHz]		amplitude of emission [dBm]	limit max. allowed emission power	actual attenuation below frequency of operation [dB]	results
		--	17 dBm		Operating frequency
		--	17 dBm		Operating frequency
		--	17 dBm		Operating frequency
Measurement uncertainty		± 3dB			

RBW : 1 MHz VBW: 1 MHz

Under normal test conditions only	In any 100 kHz bandwidth outside the frequency band at least 20dB below the highest level of the desired power. In addition, radiated emissions which fall in the restricted bands, as defined in §15.205(a), must also comply with the radiated emission limits specified in §15.209(a) (see §15.205(c)).
-----------------------------------	--

Note: For emissions that fall into restricted bands you find the radiated emissions later in the report.

3.11 MPE calculation

These equations are generally accurate in the far field of an antenna but will over predict power density in the near field, where they could be used for making a “worst case” prediction.

$$S = PG/4\pi R^2$$

where S = power density (in appropriate units, e.g. mW/cm²)
P = power input to the antenna (in appropriate units e.g. mW)
G = power gain of the antenna in the direction of interest relative to the isotropic radiator
R = distance to the center of radiation of the antenna (appropriate units e.g. cm)

Or

$$S = EIRP/4\pi R^2$$

where EIRP = equivalent isotropically radiated power

Calculation:

(Calculated for max. EIRP)

EIRP: 19.77 dBm = 94.84 mW (Peak power)
calculated at distance of 20 cm:

$$\text{power density} = 94.84 / 4\pi 20^2 = 0.0189 \text{ mW/ cm}^2$$

Limit:

1mW/ cm ² is the reference level for general public exposure according to the OET Bulletin 65, Edition 97-01 Table 1.

3.12 Max. peak output power radiated §15.247 (b) (1)

Results:

Test conditions		Max. peak output power EIRP [dBm]		
Frequency [MHz]		5180 MHz	5220 MHz	5240 MHz
T _{nom}	V _{nom}			
Measurement uncertainty		±3dB		

Note:

Calculated values. Peak power clause measurement 2 + antenna gain.

Limits:

for antennas with gain > 6 dBi	reduce the conducted output power by the amount in dB that the directional gain exceeds 6 dBi
--------------------------------	---

3.13 Spurious Emissions - radiated (Transmitter)

§15.209

Plot 1: 0.03 - 1 GHz, channel 36, low data rate, vertical / horizontal polarisation

Common Information

EUT: Philips Medizin MMS + WLAN a/b/g/ Modul
 Serial Number:
 Test Description: FCC part 15.407
 Operating Conditions: Wlan Mode A; 6 Mbits; Ch 5.180 GHz; Output Power = 11
 Operator Name: Lang
 Comment: Powered with DC 5 V

Scan Setup: FCC_Fin [EMI radiated]

Hardware Setup: Electric Field (NOS)
 Level Unit: dBµV/m

Subrange	Detectors	IF Bandwidth	Meas. Time	Receiver
30 MHz - 1 GHz	QuasiPeak	120 kHz	15 s	Receiver
1 GHz - 2 GHz	QuasiPeak	1 MHz	15 s	Receiver

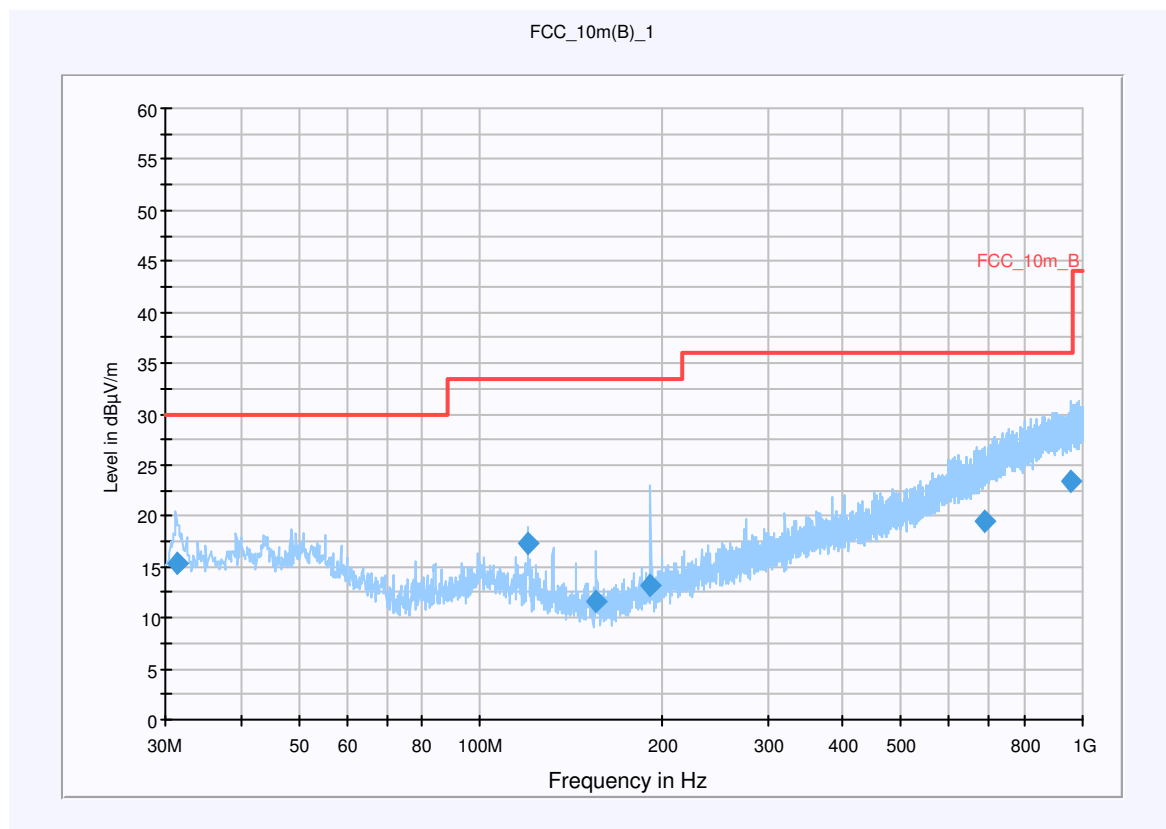

Final Result 1

Frequency (MHz)	QuasiPeak (dBµV/m)	Meas. Time (ms)	Bandwidth (kHz)	Antenna height (cm)	Polarity	Turntable position (deg)	Corr. (dB)	Margin (dB)	Limit (dBµV/m)	Comment
31.451750	15.4	15000.000	120.000	119.0	V	233.0	12.8	14.6	30.0	
120.156200	17.3	15000.000	120.000	114.0	V	46.0	10.5	16.2	33.5	
155.935850	11.5	15000.000	120.000	118.0	V	9.0	9.3	22.0	33.5	
192.046550	13.2	15000.000	120.000	100.0	V	98.0	11.3	20.3	33.5	
684.862900	19.5	15000.000	120.000	276.0	V	77.0	22.2	16.5	36.0	
957.455950	23.4	15000.000	120.000	200.0	V	13.0	26.0	12.6	36.0	

Hardware Setup: EMI radiated\Electric Field (NOS) - [EMI radiated]

Subrange 1	
Frequency Range:	30MHz - 2GHz
Receiver:	Receiver [ESCI 3] @ GPIB0 (ADR 20), SN 100083/003, FW 3.32, CAL 07.01.2009
Signal Path:	without Notch FW 1.0
Antenna:	VULB 9163 SN 9163-295, FW ---, CAL 08.04.2010 Correction Table (vertical): VULP6113 Correction Table (horizontal): VULP6113 Correction Table: Cabel with switch (0408)
Antenna Tower:	Tower [EMCO 2090 Antenna Tower] @ GPIB0 (ADR 8), FW REV 3.12
Turntable:	Turntable [EMCO Turntable] @ GPIB0 (ADR 9), FW REV 3.12

Plot 2: 1 GHz - 12 GHz, channel 36, low data rate, vertical polarisation

CETECOM ICT Services GmbH

Projekt- Nr.:1-0685-01-17_08-2

EUT:	MMS + WLAN Module	Polarisation:	Vertikal
Manufacturer:	Philips	Battery:	AC/DC Power Supply
IMEI:		HW:	
Operator:	BTL	SW:	
Start of Test :	13.02.2009 09:51:25	Vmin:	5
Standard:	FCC_15_407_5000	Vnom:	5
Signalling Unit:	CMU200	Vmax:	5
Transducer-File:	C:\Spurious_neu\Messparameter\FCC_15_407_5000\Transducer_FCC_15_407_5000.xls		
Start Freq. [MHz]:	1000	Stop Freq. [MHz]	12000

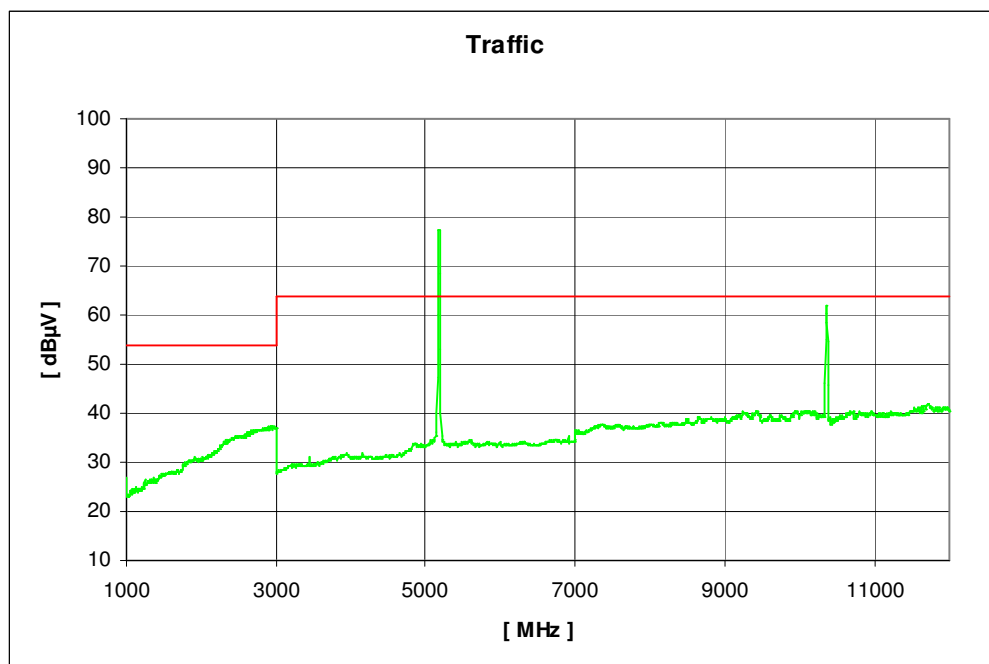

Plot 3: 1 GHz - 12 GHz, channel 36, low data rate, horizontal polarisation

CETECOM ICT Services GmbH

Projekt- Nr.:1-0685-01-17_08-2

EUT:	MMS + WLAN	Polarisation:	Horizontal
Manufacturer:	Module Philips	Battery:	AC/DC Power Supply
IMEI:		HW:	
Operator:	BTL	SW:	
Start of Test :	13.02.2009 13:33:23	Vmin:	5
Standard:	FCC_15_407_5000	Vnom:	5
Signalling Unit:	CMU200	Vmax:	5
Transducer-File:	C:\Spurious_neu\Messparameter\FCC_15_407_5000\Transducer_FCC_15_407_5000.xls		
Start Freq. [MHz]:	1000	Stop Freq. [MHz]	12000

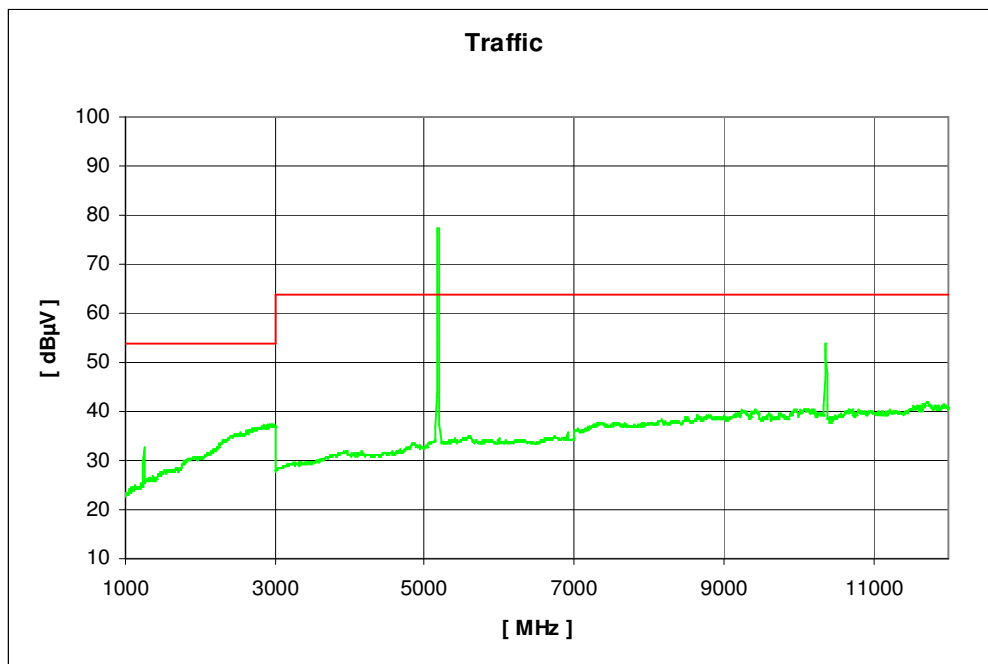

Plot 4: 12 - 18 GHz (valid for all three channels and both polarisations)

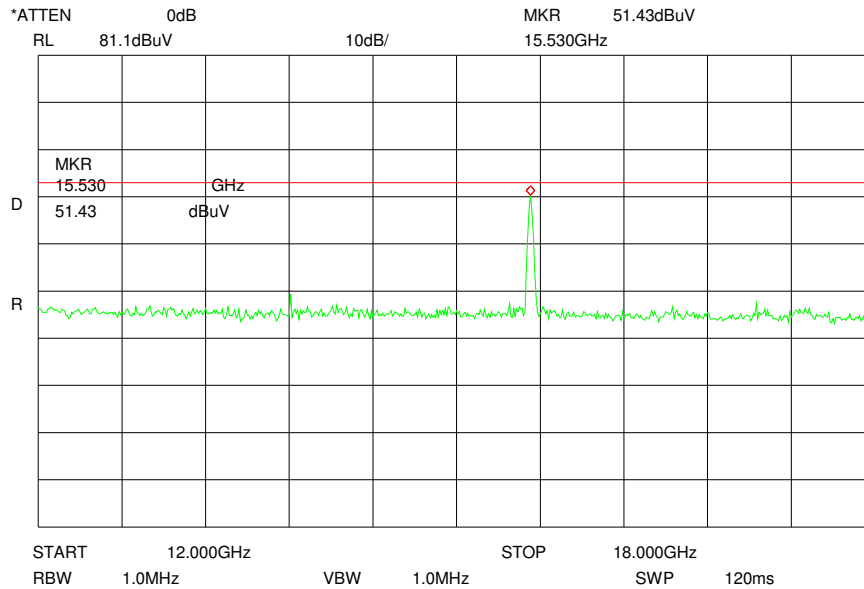

Plot 5: 18 - 26 GHz (valid for all three channels and both polarisations)

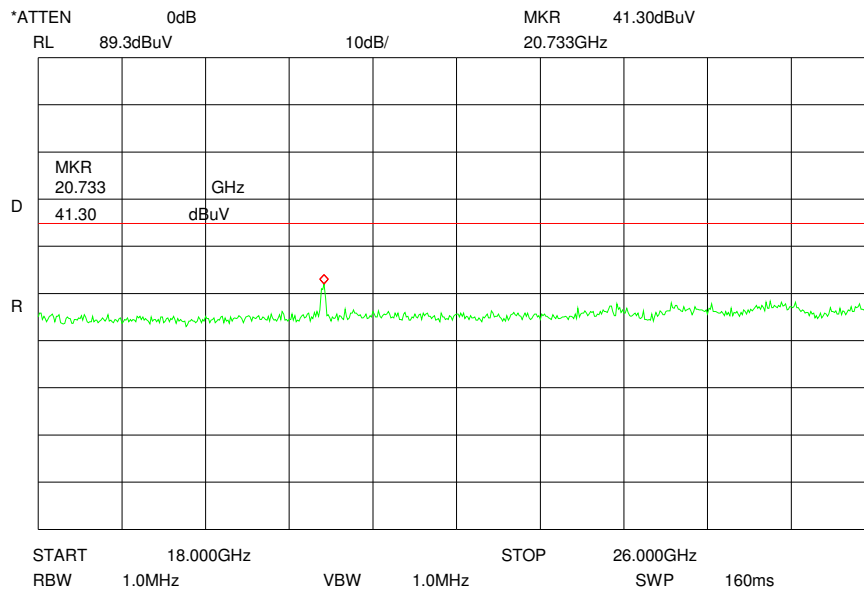

SRD-Testreport

CETECOM ICT Services GmbH Saarbruecken, Germany



Test report No.: 1-0685-01-17/08

Date: 2009-02-19

Page 27 of 102

Plot 6: 26 - 40 GHz (valid for all three channels and both polarisations)

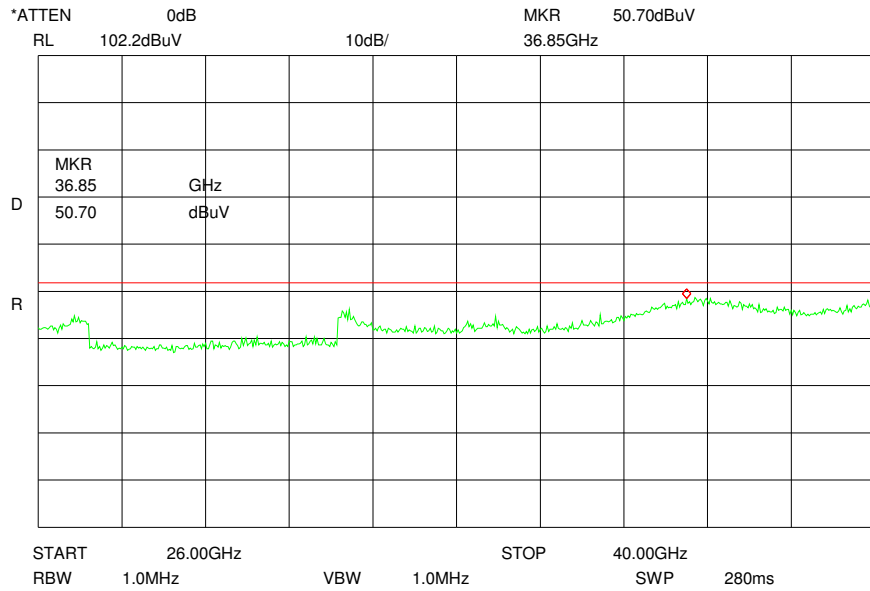

Plot 7: 0.03 - 1 GHz, channel 40, low data rate, vertical / horizontal polarisation

Common Information

EUT: Philips Medizin MMS + WLAN a/b/g/ Modul
 Serial Number:
 Test Description: FCC part 15.407
 Operating Conditions: Wlan Mode A; 6 Mbits; Ch 5.200 GHz; Output Power = 11
 Operator Name: Lang
 Comment: Powered with DC 5 V

Scan Setup: FCC_Fin [EMI radiated]

Hardware Setup: Electric Field (NOS)
 Level Unit: dBµV/m

Subrange	Detectors	IF Bandwidth	Meas. Time	Receiver
30 MHz - 1 GHz	QuasiPeak	120 kHz	15 s	Receiver
1 GHz - 2 GHz	QuasiPeak	1 MHz	15 s	Receiver

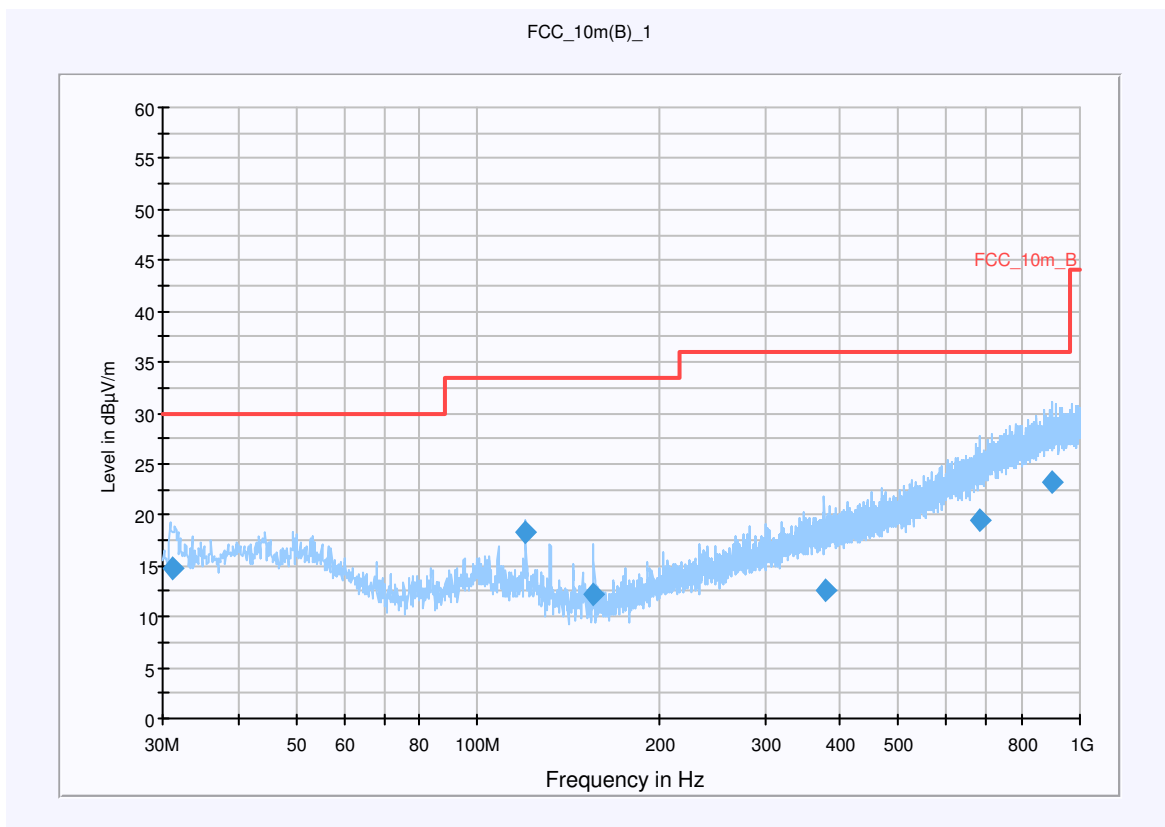

Final Result 1

Frequency (MHz)	QuasiPeak (dBµV/m)	Meas. Time (ms)	Bandwidth (kHz)	Antenna height (cm)	Polarity	Turntable position (deg)	Corr. (dB)	Margin (dB)	Limit (dBµV/m)	Comment
31.250750	14.7	15000.000	120.000	100.0	V	234.0	12.7	15.3	30.0	
120.117650	18.2	15000.000	120.000	200.0	V	45.0	10.5	15.3	33.5	
156.088700	12.2	15000.000	120.000	206.0	V	107.0	9.3	21.3	33.5	
376.764600	12.7	15000.000	120.000	200.0	V	180.0	16.6	23.3	36.0	
684.224200	19.5	15000.000	120.000	400.0	H	253.0	22.2	16.5	36.0	
898.911500	23.2	15000.000	120.000	106.0	V	231.0	25.8	12.8	36.0	

Hardware Setup: EMI radiated\Electric Field (NOS) - [EMI radiated]

Subrange 1	
Frequency Range:	30MHz - 2GHz
Receiver:	Receiver [ESCI 3] @ GPIB0 (ADR 20), SN 100083/003, FW 3.32, CAL 07.01.2009
Signal Path:	without Notch FW 1.0
Antenna:	VULB 9163 SN 9163-295, FW ---, CAL 08.04.2010 Correction Table (vertical): VULP6113 Correction Table (horizontal): VULP6113 Correction Table: Cabel with switch (0408)
Antenna Tower:	Tower [EMCO 2090 Antenna Tower] @ GPIB0 (ADR 8), FW REV 3.12
Turntable:	Turntable [EMCO Turntable] @ GPIB0 (ADR 9), FW REV 3.12

Plot 8: 1 GHz - 12 GHz, channel 40, low data rate, vertical polarisation

CETECOM ICT Services GmbH

Projekt- Nr.:1-0685-01-17_08-2

EUT:	MMS + WLAN Module	Polarisation:	Vertikal
Manufacturer:	Philips	Battery:	AC/DC Power Supply
IMEI:		HW:	
Operator:	BTL	SW:	
Start of Test :	13.02.2009 10:10:13	Vmin:	5
Standard:	FCC_15_407_5000	Vnom:	5
Signalling Unit:	CMU200	Vmax:	5
Transducer-File:	C:\Spurious_neu\Messparameter\FCC_15_407_5000\Transducer_FCC_15_407_5000.xls		
Start Freq. [MHz]:	1000	Stop Freq. [MHz]	12000

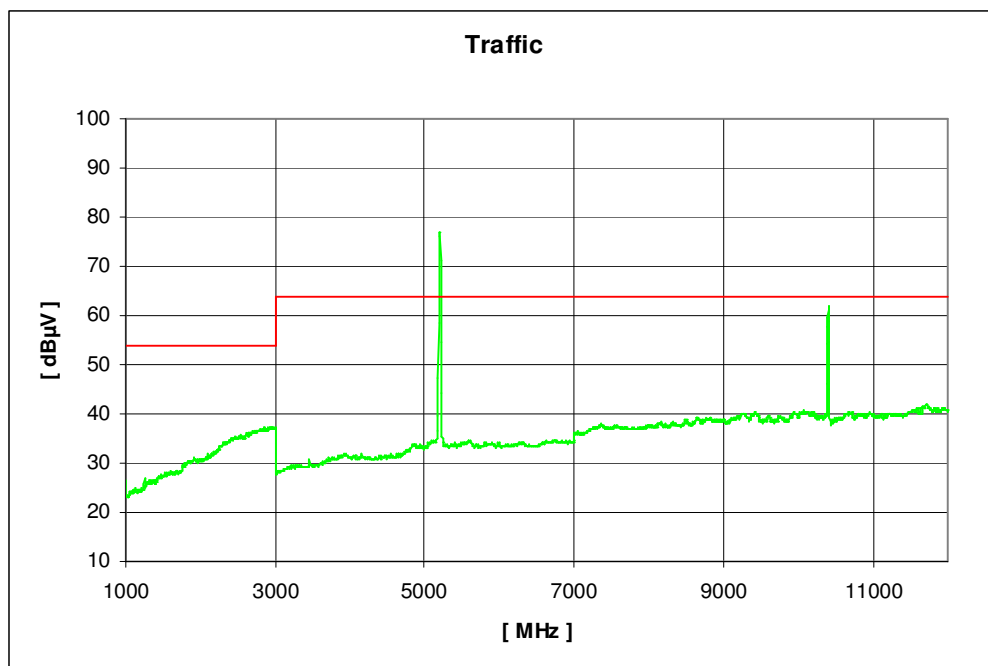

Plot 9: 1 GHz - 12 GHz, channel 40, low data rate, horizontal polarisation

CETECOM ICT Services GmbH

Projekt- Nr.:1-0685-01-17_08-2

EUT:	MMS + WLAN	Polarisation:	Horizontal
Manufacturer:	Module Philips	Battery:	AC/DC Power Supply
IMEI:		HW:	
Operator:	BTL	SW:	
Start of Test :	13.02.2009 13:17:06	Vmin:	5
Standard:	FCC_15_407_5000	Vnom:	5
Signalling Unit:	CMU200	Vmax:	5
Transducer-File:	C:\Spurious_neu\Messparameter\FCC_15_407_5000\Transducer_FCC_15_407_5000.xls		
Start Freq. [MHz]:	1000	Stop Freq. [MHz]	12000

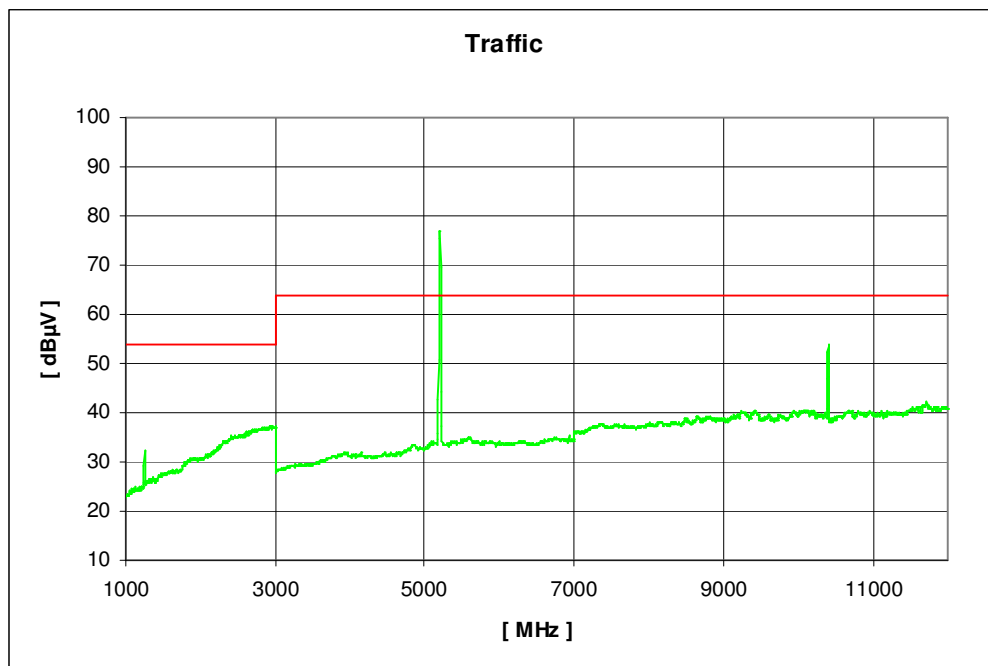

Plot 10: 0.03 - 1 GHz, channel 48, low data rate, vertical / horizontal polarisation

Common Information

EUT: Philips Medizin MMS + WLAN a/b/g/ Modul
 Serial Number:
 Test Description: FCC part 15.407
 Operating Conditions: Wlan Mode A; 6 Mbits; Ch 5.240 GHz; Output Power = 17.0
 Operator Name: Lang
 Comment: Powered with DC 5 V

Scan Setup: FCC_Fin [EMI radiated]

Hardware Setup: Electric Field (NOS)
 Level Unit: dBµV/m

Subrange	Detectors	IF Bandwidth	Meas. Time	Receiver
30 MHz - 1 GHz	QuasiPeak	120 kHz	15 s	Receiver
1 GHz - 2 GHz	QuasiPeak	1 MHz	15 s	Receiver

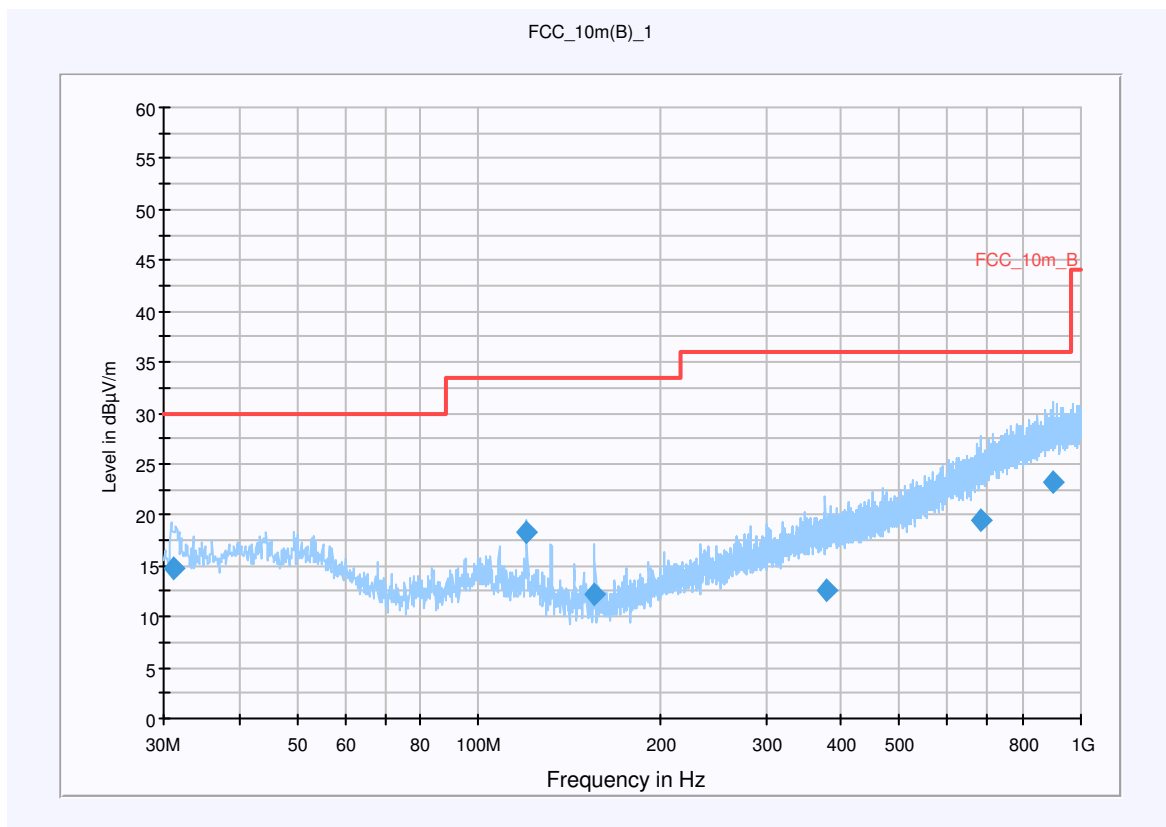

Final Result 1

Frequency (MHz)	QuasiPeak (dBµV/m)	Meas. Time (ms)	Bandwidth (kHz)	Antenna height (cm)	Polarity	Turntable position (deg)	Corr. (dB)	Margin (dB)	Limit (dBµV/m)	Comment
31.254750	14.7	15000.000	120.000	100.0	V	234.0	12.7	15.3	30.0	
120.117690	18.2	15000.000	120.000	200.0	V	45.0	10.5	15.3	33.5	
156.089700	12.2	15000.000	120.000	206.0	V	107.0	9.3	21.3	33.5	
376.784600	12.7	15000.000	120.000	200.0	V	180.0	16.6	23.3	36.0	
684.324200	19.5	15000.000	120.000	400.0	H	253.0	22.2	16.5	36.0	
898.971500	23.2	15000.000	120.000	106.0	V	231.0	25.8	12.8	36.0	

Hardware Setup: EMI radiated\Electric Field (NOS) - [EMI radiated]

Subrange 1	
Frequency Range:	30MHz - 2GHz
Receiver:	Receiver [ESCI 3] @ GPIB0 (ADR 20), SN 100083/003, FW 3.32, CAL 07.01.2009
Signal Path:	without Notch FW 1.0
Antenna:	VULB 9163 SN 9163-295, FW ---, CAL 08.04.2010 Correction Table (vertical): VULP6113 Correction Table (horizontal): VULP6113 Correction Table: Cabel with switch (0408)
Antenna Tower:	Tower [EMCO 2090 Antenna Tower] @ GPIB0 (ADR 8), FW REV 3.12
Turntable:	Turntable [EMCO Turntable] @ GPIB0 (ADR 9), FW REV 3.12

Plot 11: 1 GHz - 12 GHz, channel 48, low data rate, vertical polarisation

CETECOM ICT Services GmbH

Projekt- Nr.:1-0685-01-17_08-2

EUT:	MMS + WLAN Module	Polarisation:	Vertikal
Manufacturer:	Philips	Battery:	AC/DC Power Supply
IMEI:		HW:	
Operator:	BTL	SW:	
Start of Test :	13.02.2009 10:15:40	Vmin:	5
Standard:	FCC_15_407_5000	Vnom:	5
Signalling Unit:	CMU200	Vmax:	5
Transducer-File:	C:\Spurious_neu\Messparameter\FCC_15_407_5000\Transducer_FCC_15_407_5000.xls		
Start Freq. [MHz]:	1000	Stop Freq. [MHz]	12000

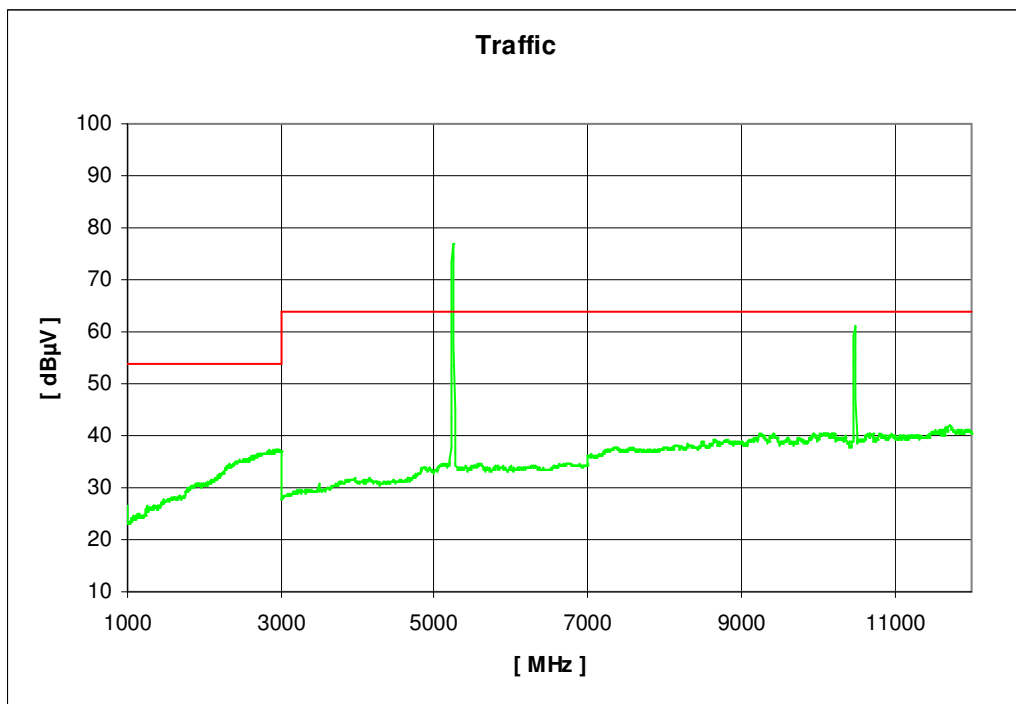

Plot 12: 1 GHz - 12 GHz, channel 48, low data rate, horizontal polarisation

CETECOM ICT Services GmbH

Projekt- Nr.:1-0685-01-17_08-2

EUT:	MMS + WLAN	Polarisation:	Horizontal
Manufacturer:	Module Philips	Battery:	AC/DC Power Supply
IMEI:		HW:	
Operator:	BTL	SW:	
Start of Test :	13.02.2009 13:11:52	Vmin:	5
Standard:	FCC_15_407_5000	Vnom:	5
Signalling Unit:	CMU200	Vmax:	5
Transducer-File:	C:\Spurious_neu\Messparameter\FCC_15_407_5000\Transducer_FCC_15_407_5000.xls		
Start Freq. [MHz]:	1000	Stop Freq. [MHz]	12000

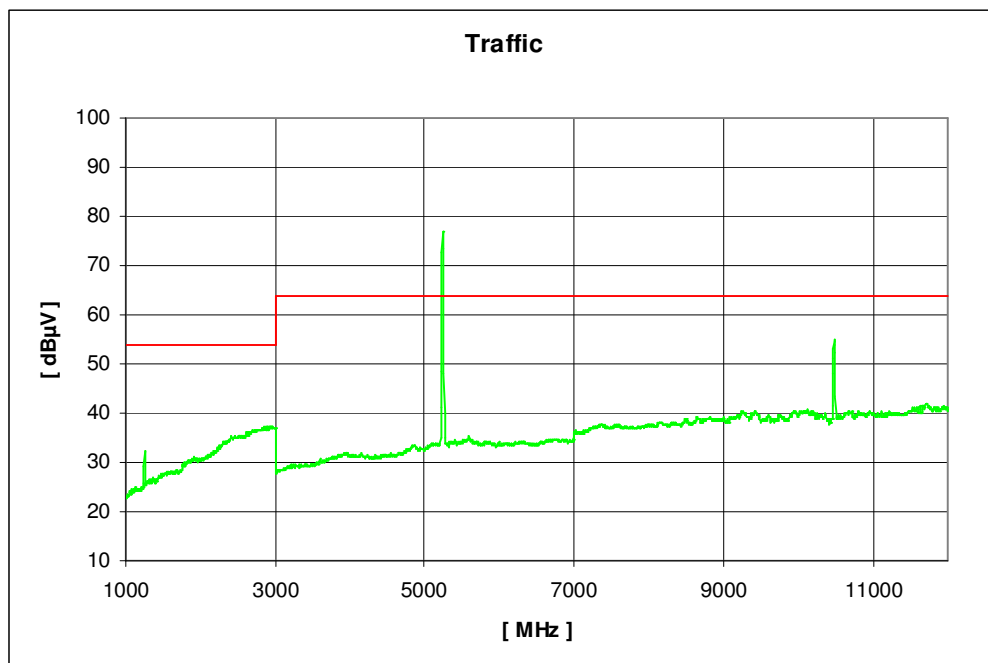

Plot 13: 0.03 - 1 GHz, channel 52, low data rate, vertical / horizontal polarisation

Common Information

EUT: Philips Medizin MMS + WLAN a/b/g/ Modul
 Serial Number:
 Test Description: FCC part 15.407
 Operating Conditions: Wlan Mode A; 6 Mbits; Ch 5.260 GHz; Output Power = 15
 Operator Name: ZAK
 Comment: Powered with DC 5 V

Scan Setup: STAN_Fin [EMI radiated]

Hardware Setup: Electric Field (NOS)
 Level Unit: dBµV/m

Subrange	Detectors	IF Bandwidth	Meas. Time	Receiver
30 MHz - 1 GHz	QuasiPeak	120 kHz	15 s	Receiver

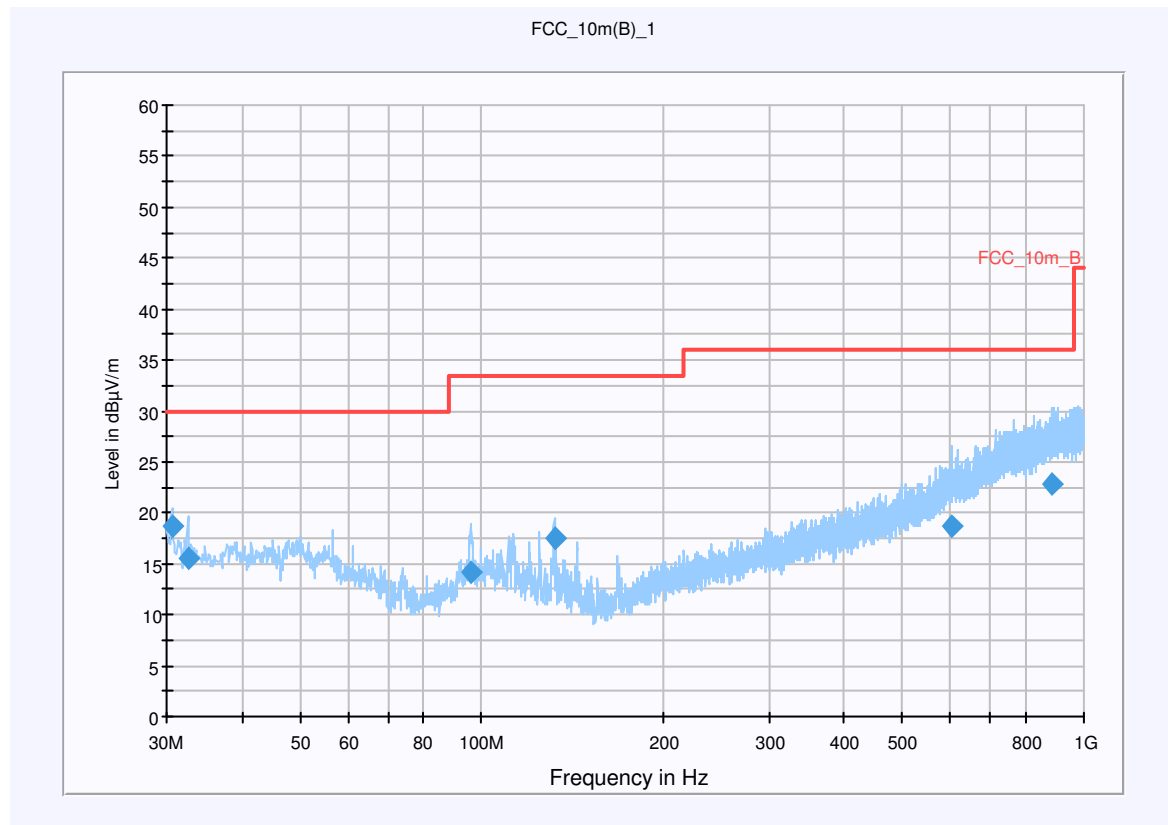

Final Result 1

Frequency (MHz)	QuasiPeak (dBµV/m)	Meas. Time (ms)	Bandwidth (kHz)	Antenna height (cm)	Polarity	Turntable position (deg)	Corr. (dB)	Margin (dB)	Limit (dBµV/m)	Comment
30.632650	18.7	15000.000	120.000	185.0	V	237.0	12.7	11.3	30.0	
32.599200	15.6	15000.000	120.000	266.0	V	277.0	12.9	14.4	30.0	
95.983650	14.2	15000.000	120.000	300.0	V	164.0	11.8	19.3	33.5	
132.099100	17.5	15000.000	120.000	100.0	V	23.0	9.5	16.0	33.5	
602.608800	18.7	15000.000	120.000	400.0	H	230.0	21.4	17.3	36.0	
882.284200	22.8	15000.000	120.000	400.0	V	68.0	25.5	13.2	36.0	

Hardware Setup: EMI radiated\Electric Field (NOS) - [EMI radiated]

Subrange 1	
Frequency Range:	30MHz - 2GHz
Receiver:	Receiver [ESCI 3] @ GPIB0 (ADR 20), SN 100083/003, FW 3.32, CAL 07.01.2009
Signal Path:	without Notch FW 1.0
Antenna:	VULB 9163 SN 9163-295, FW ---, CAL 08.04.2010 Correction Table (vertical): VULP6113 Correction Table (horizontal): VULP6113 Correction Table: Cabel with switch (0408)
Antenna Tower:	Tower [EMCO 2090 Antenna Tower] @ GPIB0 (ADR 8), FW REV 3.12
Turntable:	Turntable [EMCO Turntable] @ GPIB0 (ADR 9), FW REV 3.12

Plot 14: 1 - 12 GHz, channel 52, low data rate, vertical polarisation

CETECOM ICT Services GmbH

Projekt- Nr.:1-0685-01-17_08-2

EUT:	MMS + WLAN Module	Polarisation:	Vertikal
Manufacturer:	Philips	Battery:	AC/DC Power Supply
IMEI:		HW:	
Operator:	BTL	SW:	
Start of Test :	13.02.2009 10:55:02	Vmin:	5
Standard:	FCC_15_407_5000	Vnom:	5
Signalling Unit:	CMU200	Vmax:	5
Transducer-File:	C:\Spurious_neu\Messparameter\FCC_15_407_5000\Transducer_FCC_15_407_5000.xls		
Start Freq. [MHz]:	1000	Stop Freq. [MHz]	12000

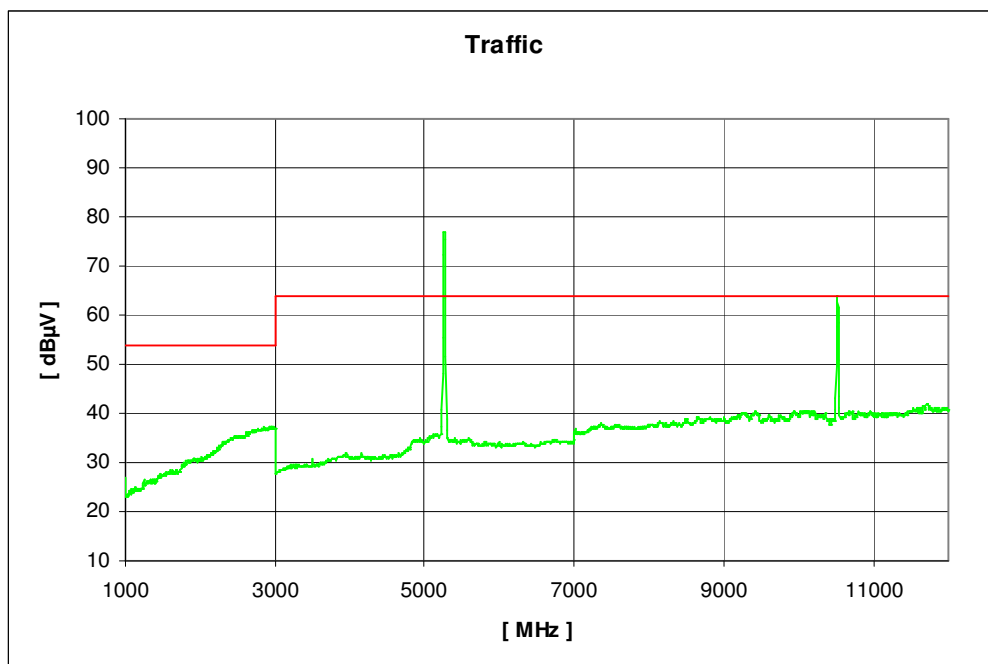

Plot 15: 1 - 12 GHz, channel 52, low data rate, horizontal polarisation

CETECOM ICT Services GmbH

Projekt- Nr.:1-0685-01-17_08-2

EUT:	MMS + WLAN	Polarisation:	Horizontal
Manufacturer:	Philips	Battery:	AC/DC Power Supply
IMEI:		HW:	
Operator:	BTL	SW:	
Start of Test :	13.02.2009 11:58:38	Vmin:	5
Standard:	FCC_15_407_5000	Vnom:	5
Signalling Unit:	CMU200	Vmax:	5
Transducer-File:	C:\Spurious_neu\Messparameter\FCC_15_407_5000\Transducer_FCC_15_407_5000.xls		
Start Freq. [MHz]:	1000	Stop Freq. [MHz]	12000

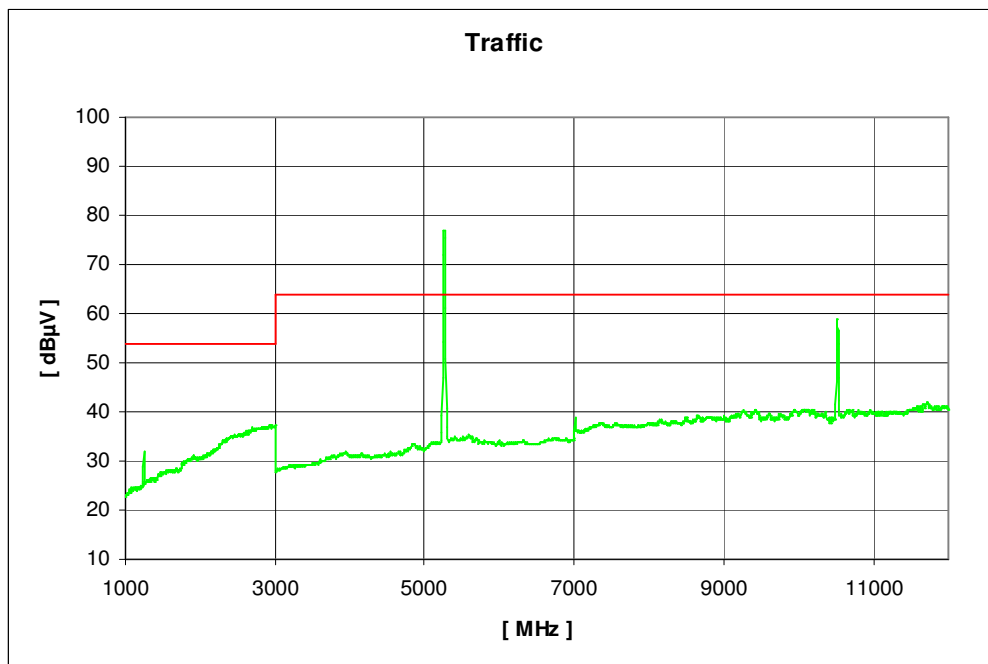

Plot 16: 12 - 18 GHz (valid for all three channels and both polarisations)

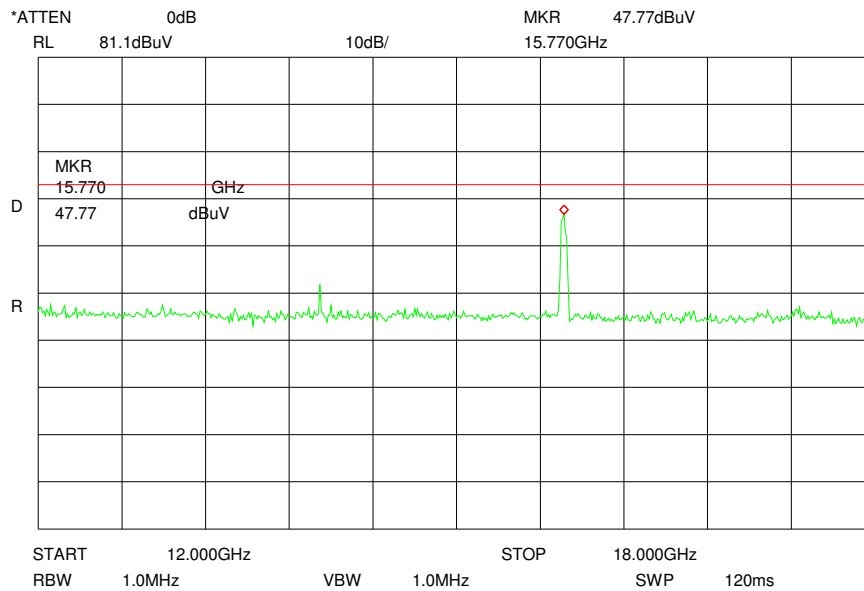

Plot 17: 18 - 26 GHz (valid for all three channels and both polarisations)

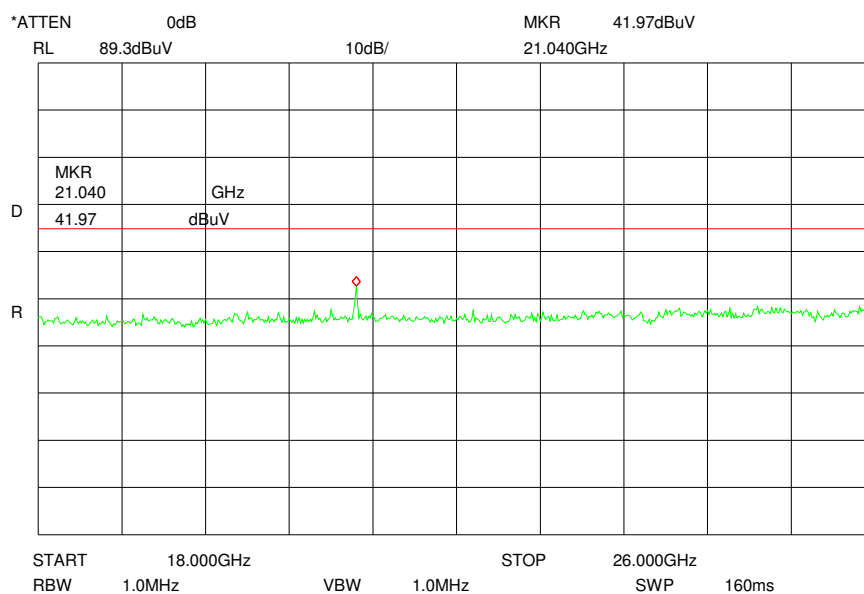

SRD-Testreport

CETECOM ICT Services GmbH Saarbruecken, Germany



Test report No.: 1-0685-01-17/08

Date: 2009-02-19

Page 41 of 102

Plot 18: 26 - 40 GHz (valid for all three channels and both polarisations)

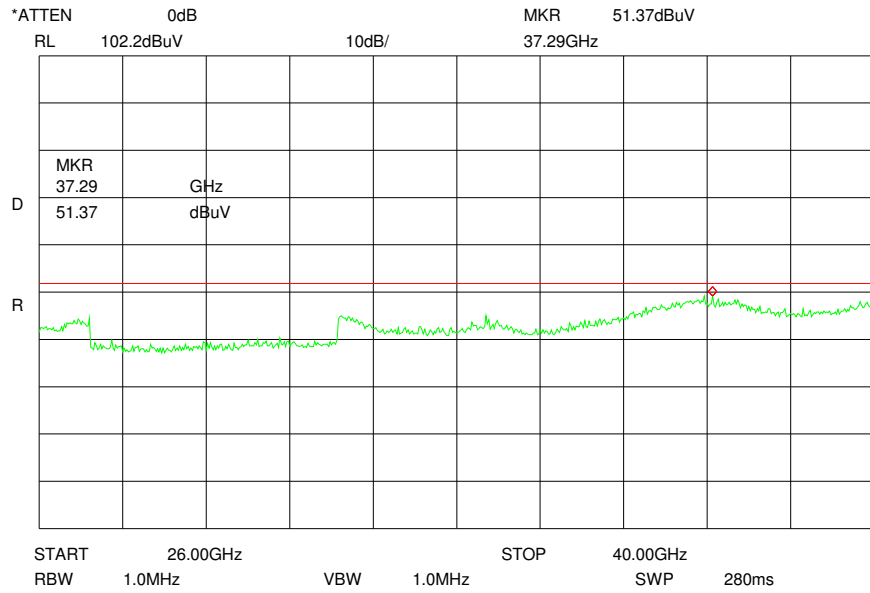

Plot 19: 0.03 - 1 GHz, channel 56, low data rate, vertical / horizontal polarisation

Common Information

EUT: Philips Medizin MMS + WLAN a/b/g/ Modul
 Serial Number:
 Test Description: FCC part 15.407
 Operating Conditions: Wlan Mode A; 6 Mbits; Ch 5.280 GHz; Output Power = 15
 Operator Name: ZAK
 Comment: Powered with DC 5 V

Scan Setup: STAN_Fin [EMI radiated]

Hardware Setup: Electric Field (NOS)
 Level Unit: dBµV/m

Subrange	Detectors	IF Bandwidth	Meas. Time	Receiver
30 MHz - 1 GHz	QuasiPeak	120 kHz	15 s	Receiver

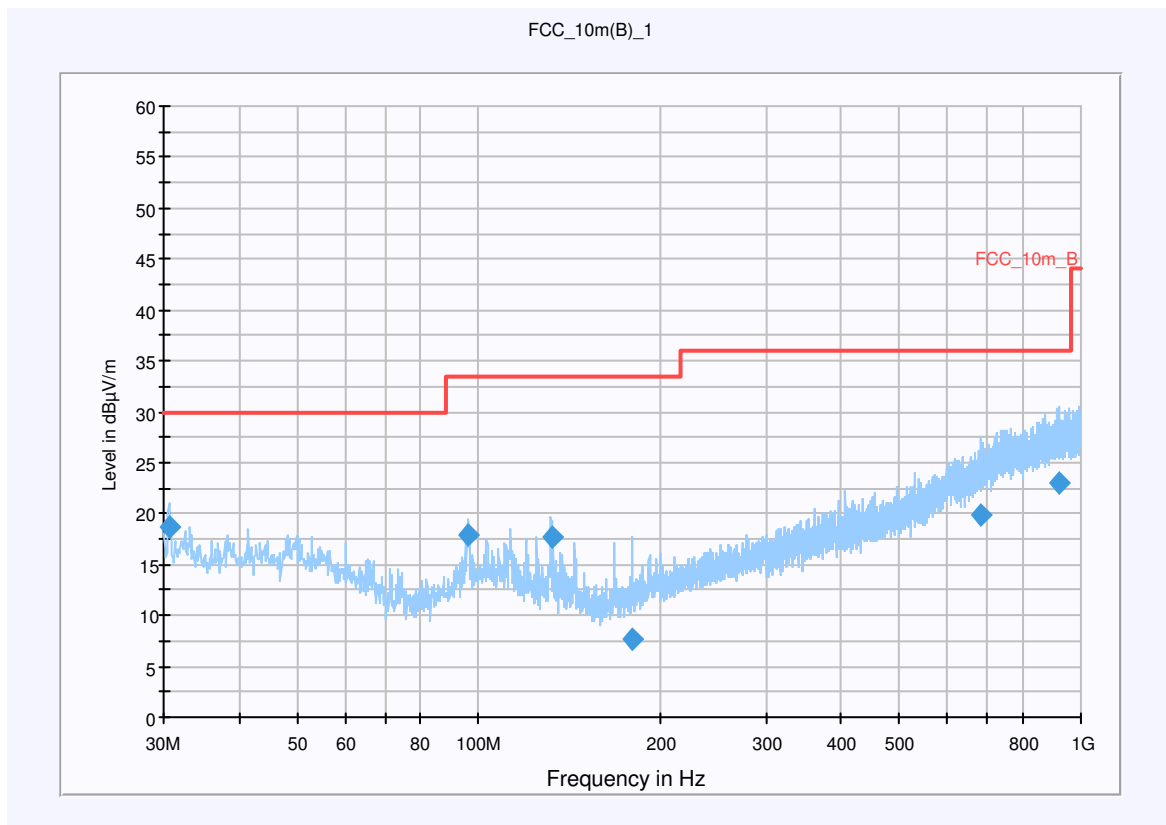

Final Result 1

Frequency (MHz)	QuasiPeak (dBµV/m)	Meas. Time (ms)	Bandwidth (kHz)	Antenna height (cm)	Polarity	Turntable position (deg)	Corr. (dB)	Margin (dB)	Limit (dBµV/m)	Comment
30.632350	18.7	15000.000	120.000	200.0	V	202.0	12.7	11.3	30.0	
95.788400	18.0	15000.000	120.000	130.0	V	233.0	11.7	15.5	33.5	
131.985800	17.8	15000.000	120.000	136.0	V	46.0	9.5	15.7	33.5	
180.193700	7.7	15000.000	120.000	200.0	V	171.0	10.7	25.8	33.5	
682.983550	19.8	15000.000	120.000	361.0	V	266.0	22.6	16.2	36.0	
919.516600	23.0	15000.000	120.000	200.0	H	27.0	25.8	13.0	36.0	

Hardware Setup: EMI radiated\Electric Field (NOS) - [EMI radiated]

Subrange 1	
Frequency Range:	30MHz - 2GHz
Receiver:	Receiver [ESCI 3] @ GPIB0 (ADR 20), SN 100083/003, FW 3.32, CAL 07.01.2009
Signal Path:	without Notch FW 1.0
Antenna:	VULB 9163 SN 9163-295, FW ---, CAL 08.04.2010 Correction Table (vertical): VULP6113 Correction Table (horizontal): VULP6113 Correction Table: Cabel with switch (0408)
Antenna Tower:	Tower [EMCO 2090 Antenna Tower] @ GPIB0 (ADR 8), FW REV 3.12
Turntable:	Turntable [EMCO Turntable] @ GPIB0 (ADR 9), FW REV 3.12

Plot 20: 1 - 12 GHz, channel 56, low data rate, vertical polarisation

CETECOM ICT Services GmbH

Projekt- Nr.:1-0685-01-17_08-2

EUT:	MMS + WLAN Module	Polarisation:	Vertikal
Manufacturer:	Philips	Battery:	AC/DC Power Supply
IMEI:		HW:	
Operator:	BTL	SW:	
Start of Test :	13.02.2009 11:02:28	Vmin:	5
Standard:	FCC_15_407_5000	Vnom:	5
Signalling Unit:	CMU200	Vmax:	5
Transducer-File:	C:\Spurious_neu\Messparameter\FCC_15_407_5000\Transducer_FCC_15_407_5000.xls		
Start Freq. [MHz]:	1000	Stop Freq. [MHz]	12000

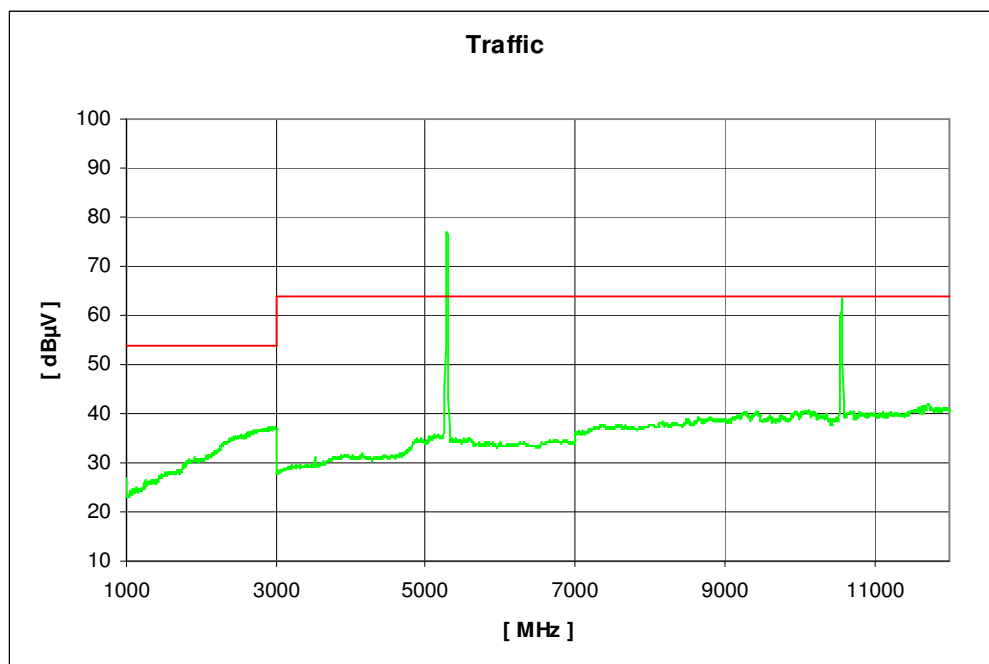

Plot 21: 1 - 12 GHz, channel 56, low data rate, horizontal polarisation

CETECOM ICT Services GmbH

Projekt- Nr.:1-0685-01-17_08-2

EUT:	MMS + WLAN	Polarisation:	Horizontal
Manufacturer:	Philips	Battery:	AC/DC Power Supply
IMEI:		HW:	
Operator:	BTL	SW:	
Start of Test :	13.02.2009 11:52:06	Vmin:	5
Standard:	FCC_15_407_5000	Vnom:	5
Signalling Unit:	CMU200	Vmax:	5
Transducer-File:	C:\Spurious_neu\Messparameter\FCC_15_407_5000\Transducer_FCC_15_407_5000.xls		
Start Freq. [MHz]:	1000	Stop Freq. [MHz]	12000

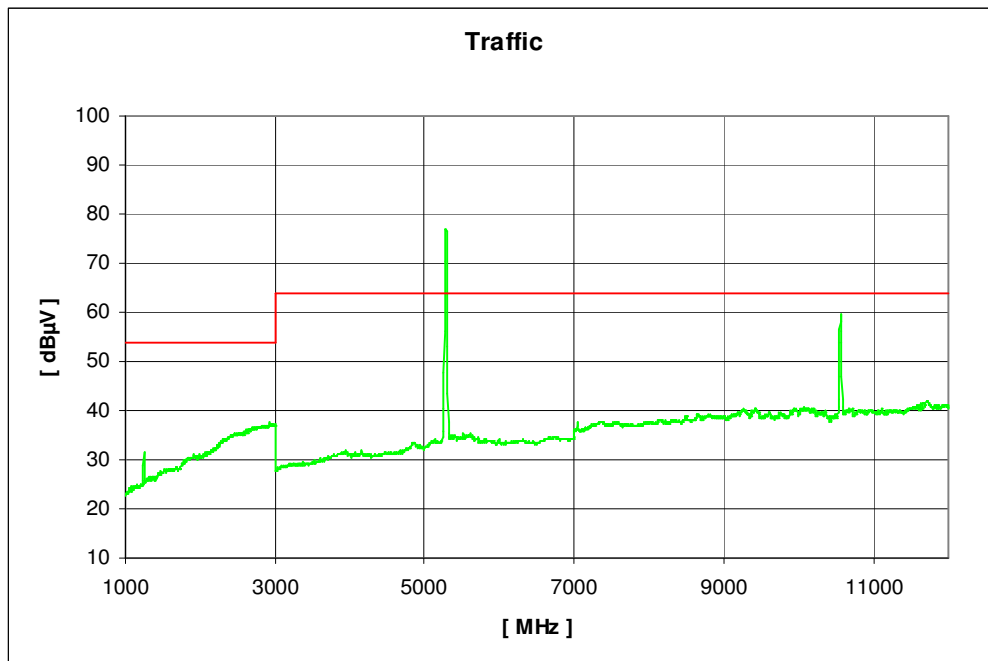

Plot 22: 0.03 - 1 GHz, channel 64, low data rate, vertical / horizontal polarisation

Common Information

EUT: Philips Medizin MMS + WLAN a/b/g Modul
 Serial Number: Antenna M8100-66490
 Test Description: FCC part 15.407
 Operating Conditions: WLAN Mode A 6Mbit; Ch 5.320 GHz; Output Power = 15
 Operator Name: Lang
 Comment: Powerd with DC 5 V

Scan Setup: FCC_Fin [EMI radiated]

Hardware Setup: Electric Field (NOS)
 Level Unit: dBµV/m

Subrange	Detectors	IF Bandwidth	Meas. Time	Receiver
30 MHz - 1 GHz	QuasiPeak	120 kHz	15 s	Receiver

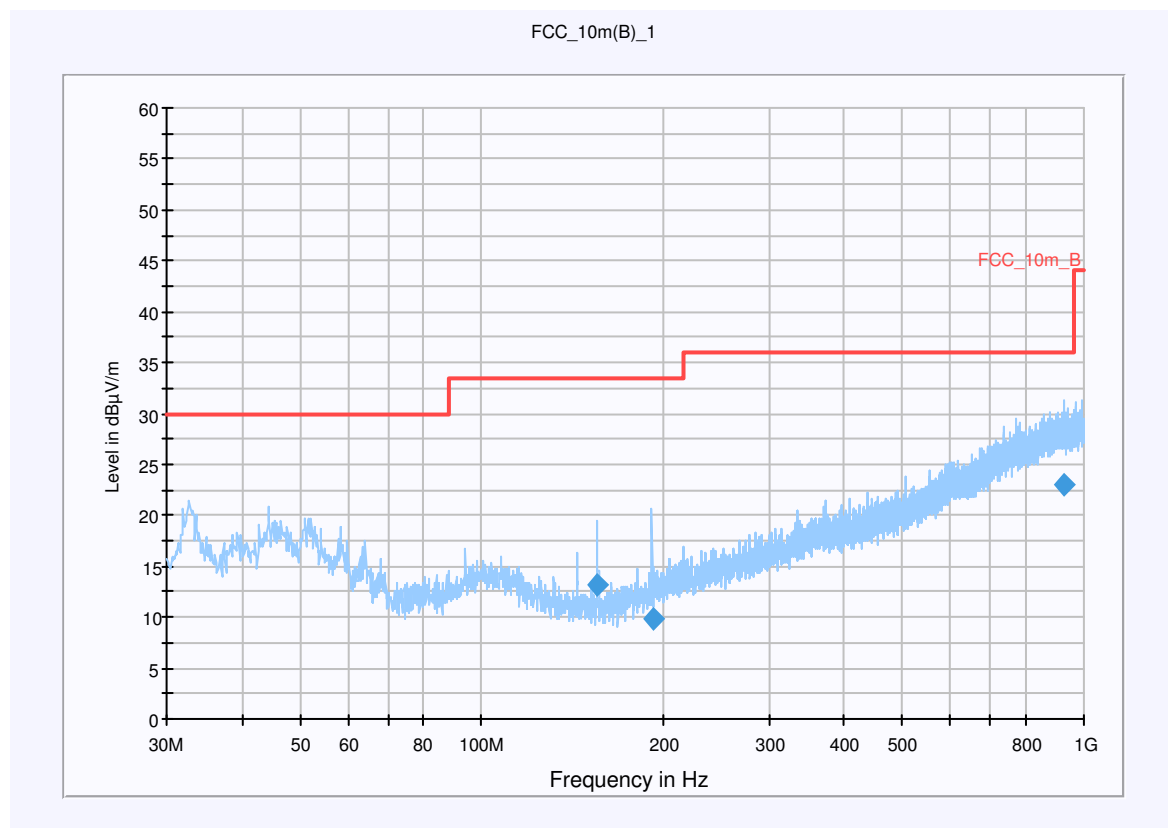

Final Result 1

Frequency (MHz)	QuasiPeak (dBµV/m)	Meas. Time (ms)	Bandwidth (kHz)	Antenna height (cm)	Polarity	Turntable position (deg)	Corr. (dB)	Margin (dB)	Limit (dBµV/m)	Comment
155.998100	13.2	15000.000	120.000	227.0	V	310.0	9.3	20.3	33.5	
192.097250	9.8	15000.000	120.000	100.0	V	222.0	11.3	23.7	33.5	
927.551400	23.0	15000.000	120.000	200.0	H	41.0	25.9	13.0	36.0	

Hardware Setup: EMI radiated\Electric Field (NOS) - [EMI radiated]

Subrange 1	
Frequency Range:	30MHz - 2GHz
Receiver:	Receiver [ESCI 3] @ GPIB0 (ADR 20), SN 100083/003, FW 3.32, CAL 07.01.2009
Signal Path:	without Notch FW 1.0
Antenna:	VULB 9163 SN 9163-295, FW ---, CAL 08.04.2010 Correction Table (vertical): VULP6113 Correction Table (horizontal): VULP6113 Correction Table: Cabel with switch (0408)
Antenna Tower:	Tower [EMCO 2090 Antenna Tower] @ GPIB0 (ADR 8), FW REV 3.12
Turntable:	Turntable [EMCO Turntable] @ GPIB0 (ADR 9), FW REV 3.12

Plot 23: 1 - 12 GHz, channel 64, low data rate, vertical polarisation

CETECOM ICT Services GmbH

Projekt- Nr.:1-0685-01-17_08-2

EUT:	MMS + WLAN Module	Polarisation:	Vertikal
Manufacturer:	Philips	Battery:	AC/DC Power Supply
IMEI:		HW:	
Operator:	BTL	SW:	
Start of Test :	13.02.2009 11:25:00	Vmin:	5
Standard:	FCC_15_407_5000	Vnom:	5
Signalling Unit:	CMU200	Vmax:	5
Transducer-File:	C:\Spurious_neu\Messparameter\FCC_15_407_5000\Transducer_FCC_15_407_5000.xls		
Start Freq. [MHz]:	1000	Stop Freq. [MHz]	12000

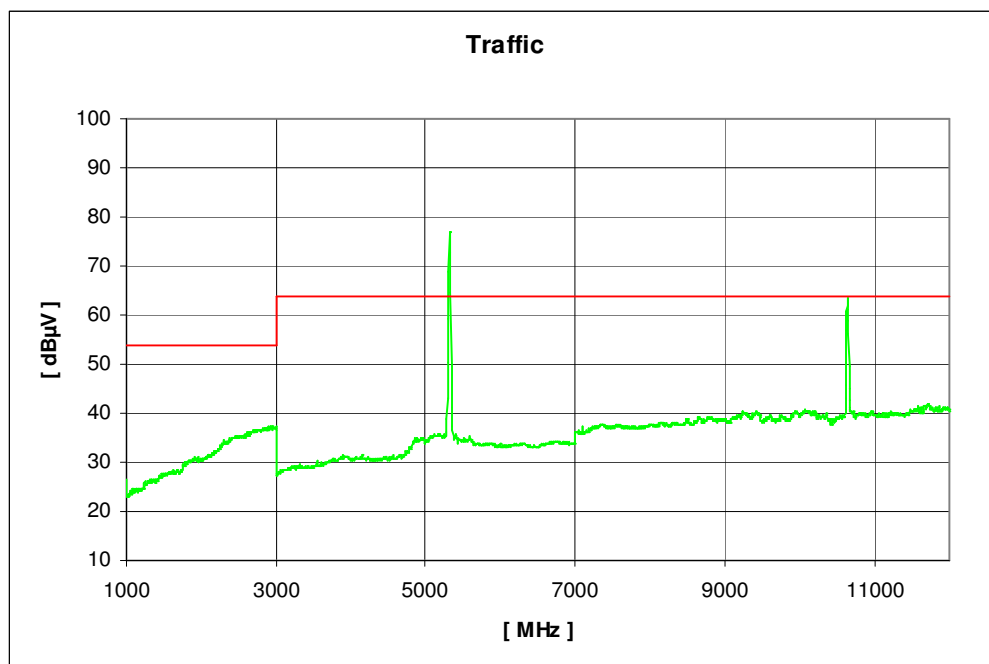

Plot 24: 1 - 12 GHz, channel 64, low data rate, horizontal polarisation

CETECOM ICT Services GmbH

Projekt- Nr.:1-0685-01-17_08-2

EUT:	MMS + WLAN	Polarisation:	Horizontal
Manufacturer:	Module Philips	Battery:	AC/DC Power Supply
IMEI:		HW:	
Operator:	BTL	SW:	
Start of Test :	13.02.2009 11:30:31	Vmin:	5
Standard:	FCC_15_407_5000	Vnom:	5
Signalling Unit:	CMU200	Vmax:	5
Transducer-File:	C:\Spurious_neu\Messparameter\FCC_15_407_5000\Transducer_FCC_15_407_5000.xls		
Start Freq. [MHz]:	1000	Stop Freq. [MHz]	12000

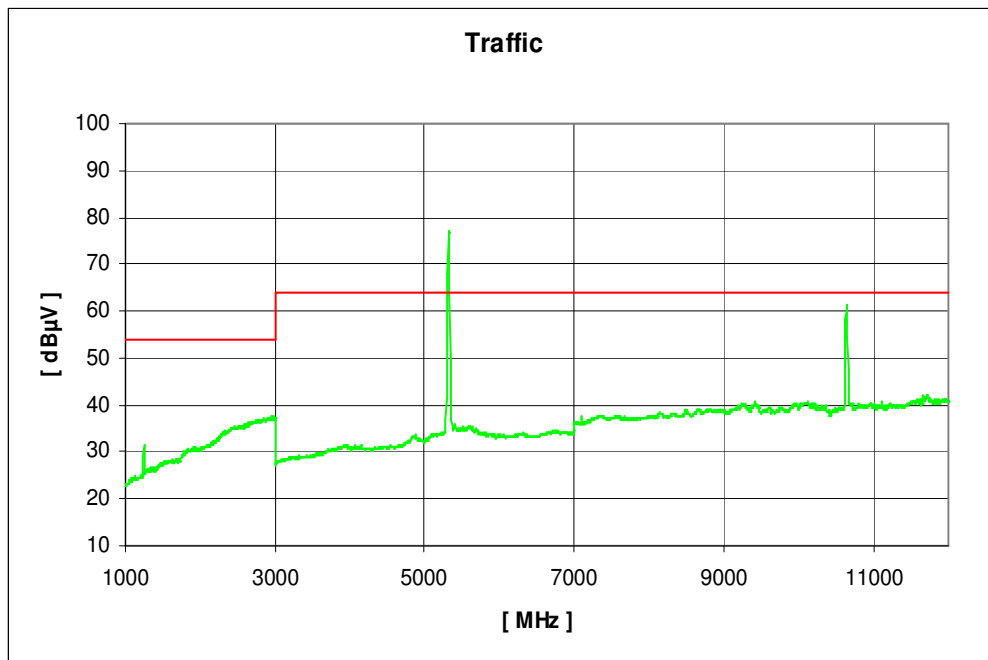

SRD-Testreport

CETECOM ICT Services GmbH Saarbruecken, Germany



Test report No.: 1-0685-01-17/08

Date: 2009-02-19

Page 50 of 102

Results:

Spurious Emissions level [$\mu\text{V/m}$]								
Channel 36			Channel 40			Channel 48		
f[GHz]	Detector	Level [$\mu\text{V/m}$]	f[GHz]	Detector	Level [$\mu\text{V/m}$]	f[GHz]	Detector	Level [$\mu\text{V/m}$]
10.37	AV	60.33 @ 1 m	10.40	AV	61.93	10.49	AV	61.07
15.53	PP	51.43 @ 37.5 cm 42.91 @ 1 m						
20.73	PP	41.30 @ 37.5 cm 32.78 @ 1 m						
36.85	PP	50.70 @ 37.5 cm 42.18 @ 1 m						
Measurement uncertainty			± 3 dB					

$f < 1$ GHz: RBW/VBW: 100 kHz

$f \geq 1$ GHz: RBW/VBW: 1 MHz

see above plots

Measurement distance: 1 – 3 GHz = 3m
 3 – 12 GHz = 1m
 12 GHz – 40 GHz = 37.5 cm

SRD-Testreport

CETECOM ICT Services GmbH Saarbruecken, Germany



Test report No.: 1-0685-01-17/08

Date: 2009-02-19

Page 51 of 102

Results:

Spurious Emissions level [$\mu\text{V/m}$]								
Channel 52			Channel 56			Channel 64		
f[GHz]	Detector	Level [$\mu\text{V/m}$]	f[GHz]	Detector	Level [$\mu\text{V/m}$]	f[GHz]	Detector	Level [$\mu\text{V/m}$]
10.52	AV	63.83 @ 1 m	10.56	AV	63.59 @ 1 m	10.64	AV	63.45 @ 1 m
15.77	PP	47.77 @ 37.5 cm 29.25 @ 1 m						
21.04	PP	41.97 @ 37.5 cm 33.45 @ 1 m						
37.29	PP	51.37 @ 37.5 cm 42.85 @ 1 m						
Measurement uncertainty			± 3 dB					

$f < 1$ GHz: RBW/VBW: 100 kHz

$f \geq 1$ GHz: RBW/VBW: 1 MHz

see above plots

Measurement distance: 1 – 3 GHz = 3m
 3 – 12 GHz = 1m
 12 GHz – 40 GHz = 37.5 cm

Limits :

Under normal test conditions only	See plots
-----------------------------------	-----------

Plot 1: 0.03 - 1 GHz, channel 36, high data rate, vertical / horizontal polarisation

Common Information

EUT: Philips Medizin MMS + WLAN a/b/g/ Modul
 Serial Number:
 Test Description: FCC part 15.407
 Operating Conditions: Wlan Mode A; 54 Mbits; Ch 5.180 GHz; Output Power = 11
 Operator Name: ZAK
 Comment: Powered with DC 5 V

Scan Setup: STAN_Fin [EMI radiated]

Hardware Setup: Electric Field (NOS)
 Level Unit: dBµV/m

Subrange	Detectors	IF Bandwidth	Meas. Time	Receiver
30 MHz - 1 GHz	QuasiPeak	120 kHz	15 s	Receiver

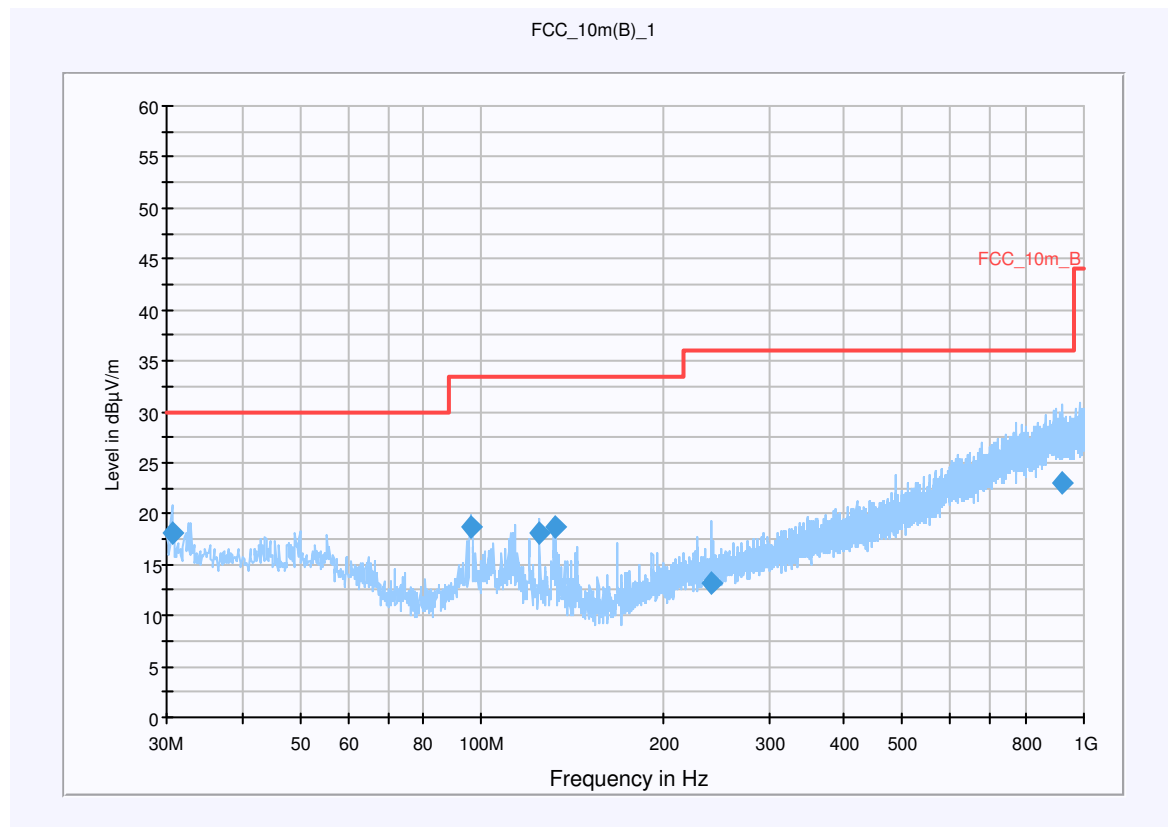

Final Result 1

Frequency (MHz)	QuasiPeak (dBµV/m)	Meas. Time (ms)	Bandwidth (kHz)	Antenna height (cm)	Polarity	Turntable position (deg)	Corr. (dB)	Margin (dB)	Limit (dBµV/m)	Comment
30.603850	18.1	15000.000	120.000	114.0	V	35.0	12.7	11.9	30.0	
95.785500	18.7	15000.000	120.000	116.0	V	154.0	11.7	14.8	33.5	
125.011500	18.2	15000.000	120.000	100.0	V	192.0	10.1	15.3	33.5	
132.049050	18.7	15000.000	120.000	125.0	V	92.0	9.5	14.8	33.5	
240.051650	13.3	15000.000	120.000	200.0	V	104.0	13.3	22.8	36.0	
921.736500	23.0	15000.000	120.000	200.0	H	233.0	25.8	13.0	36.0	

Hardware Setup: EMI radiated\Electric Field (NOS) - [EMI radiated]

Subrange 1	
Frequency Range:	30MHz - 2GHz
Receiver:	Receiver [ESCI 3] @ GPIB0 (ADR 20), SN 100083/003, FW 3.32, CAL 07.01.2009
Signal Path:	without Notch FW 1.0
Antenna:	VULB 9163 SN 9163-295, FW ---, CAL 08.04.2010 Correction Table (vertical): VULP6113 Correction Table (horizontal): VULP6113 Correction Table: Cabel with switch (0408)
Antenna Tower:	Tower [EMCO 2090 Antenna Tower] @ GPIB0 (ADR 8), FW REV 3.12
Turntable:	Turntable [EMCO Turntable] @ GPIB0 (ADR 9), FW REV 3.12

Plot 2: 1 GHz - 12 GHz, channel 36, high data rate, vertical polarisation

CETECOM ICT Services GmbH

Projekt- Nr.:1-0685-01-17_08-2

EUT:	MMS + WLAN Module	Polarisation:	Vertikal
Manufacturer:	Philips	Battery:	AC/DC Power Supply
IMEI:		HW:	
Operator:	BTL	SW:	
Start of Test :	13.02.2009 09:57:59	Vmin:	5
Standard:	FCC_15_407_5000	Vnom:	5
Signalling Unit:	CMU200	Vmax:	5
Transducer-File:	C:\Spurious_neu\Messparameter\FCC_15_407_5000\Transducer_FCC_15_407_5000.xls		
Start Freq. [MHz]:	1000	Stop Freq. [MHz]	12000

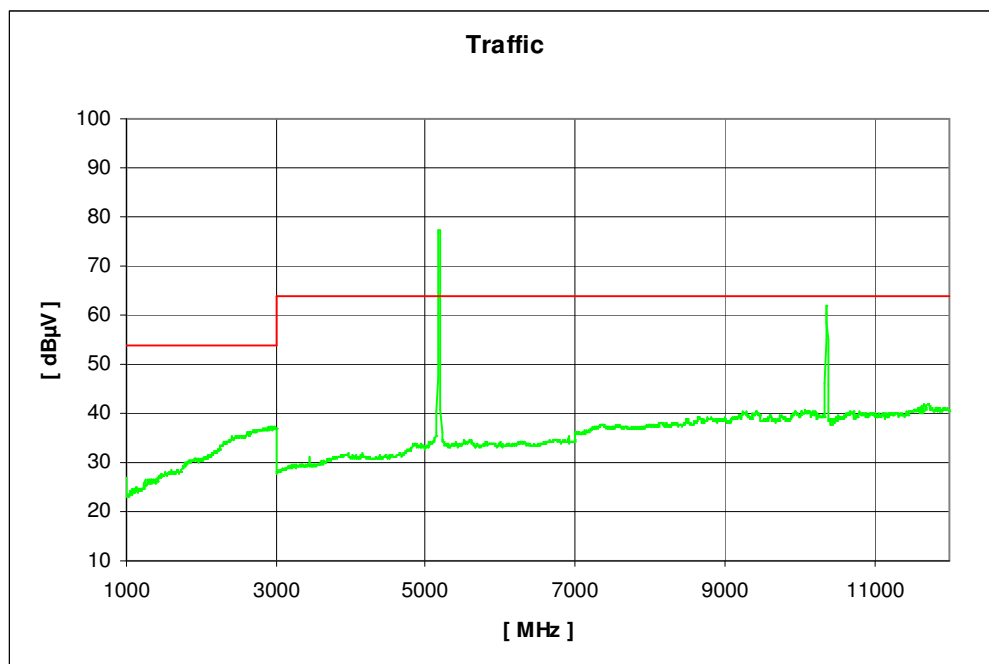

Plot 3: 1 GHz - 12 GHz, channel 36, high data rate, horizontal polarisation

CETECOM ICT Services GmbH

Projekt- Nr.:1-0685-01-17_08-2

EUT:	MMS + WLAN	Polarisation:	Horizontal
Manufacturer:	Philips	Battery:	AC/DC Power Supply
IMEI:		HW:	
Operator:	BTL	SW:	
Start of Test :	13.02.2009 13:28:26	Vmin:	5
Standard:	FCC_15_407_5000	Vnom:	5
Signalling Unit:	CMU200	Vmax:	5
Transducer-File:	C:\Spurious_neu\Messparameter\FCC_15_407_5000\Transducer_FCC_15_407_5000.xls		
Start Freq. [MHz]:	1000	Stop Freq. [MHz]	12000

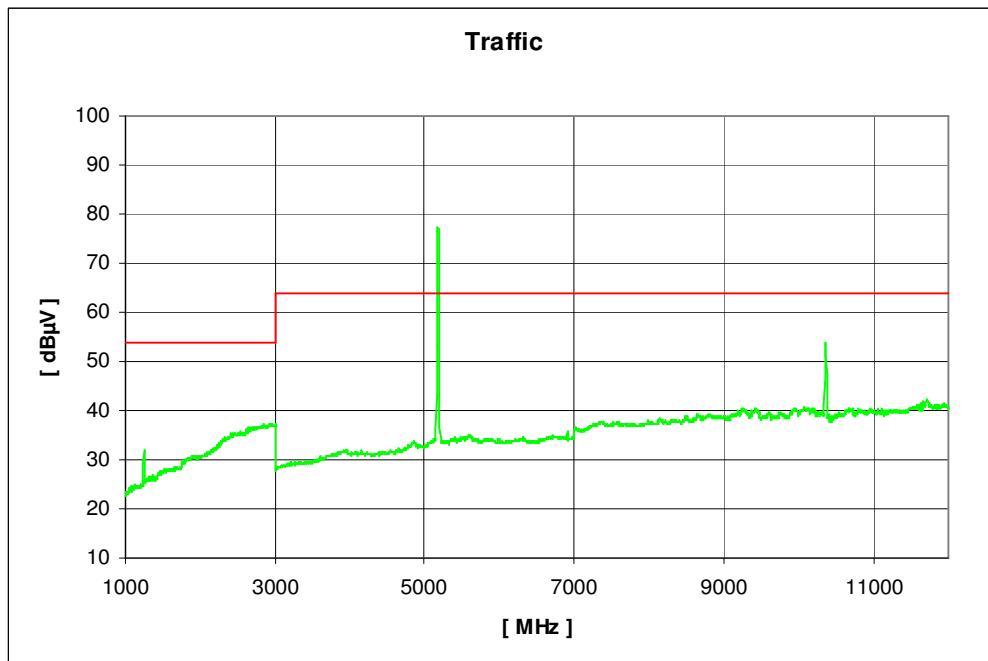

Plot 4: 12 - 18 GHz (valid for all three channels and both polarisations)

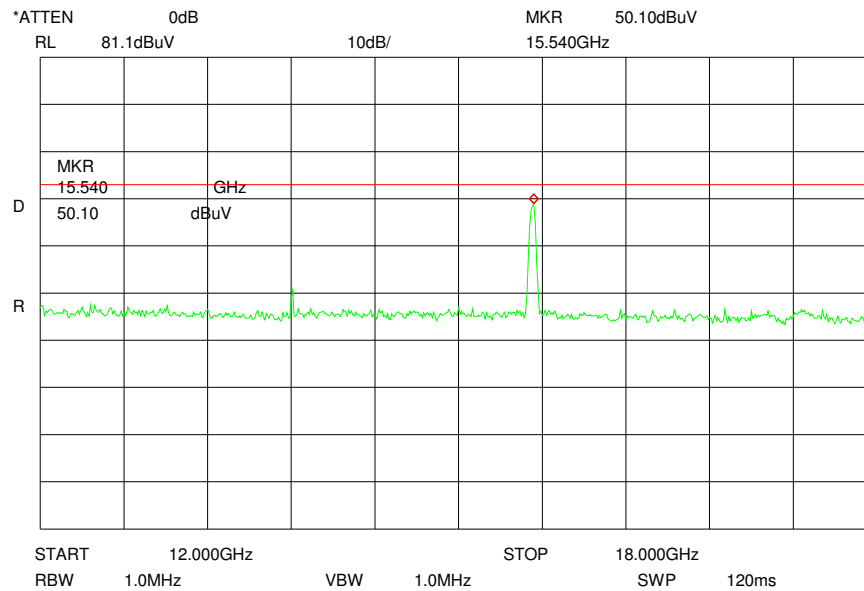

Plot 5: 18 - 26 GHz (valid for all three channels and both polarisations)

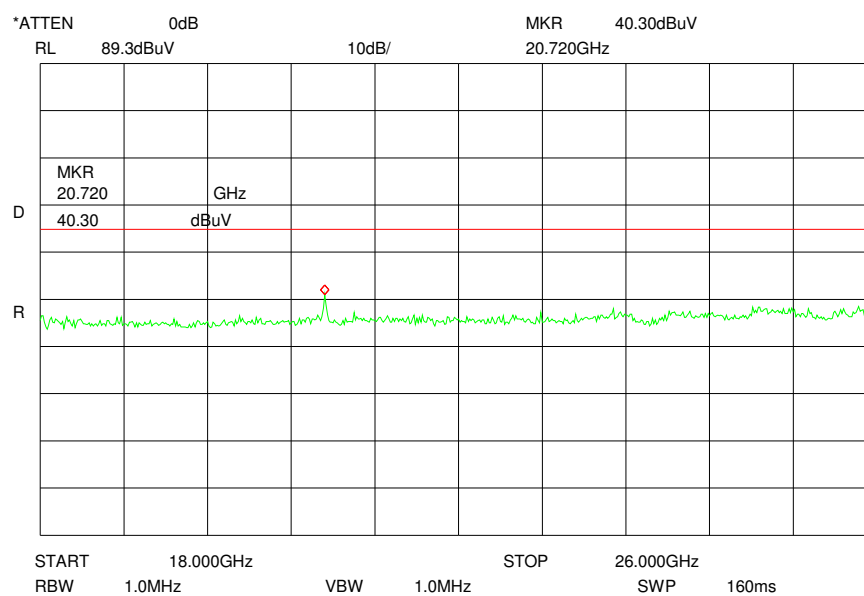

Plot 7: 0.03 - 1 GHz, channel 40, high data rate, vertical / horizontal polarisation

Common Information

EUT: Philips Medizin MMS + WLAN a/b/g/ Modul
 Serial Number:
 Test Description: FCC part 15.407
 Operating Conditions: Wlan Mode A; 54 Mbits; Ch 5.200 GHz; Output Power = 11
 Operator Name: ZAK
 Comment: Powered with DC 5 V

Scan Setup: STAN_Fin [EMI radiated]

Hardware Setup: Electric Field (NOS)
 Level Unit: dBµV/m

Subrange	Detectors	IF Bandwidth	Meas. Time	Receiver
30 MHz - 1 GHz	QuasiPeak	120 kHz	15 s	Receiver

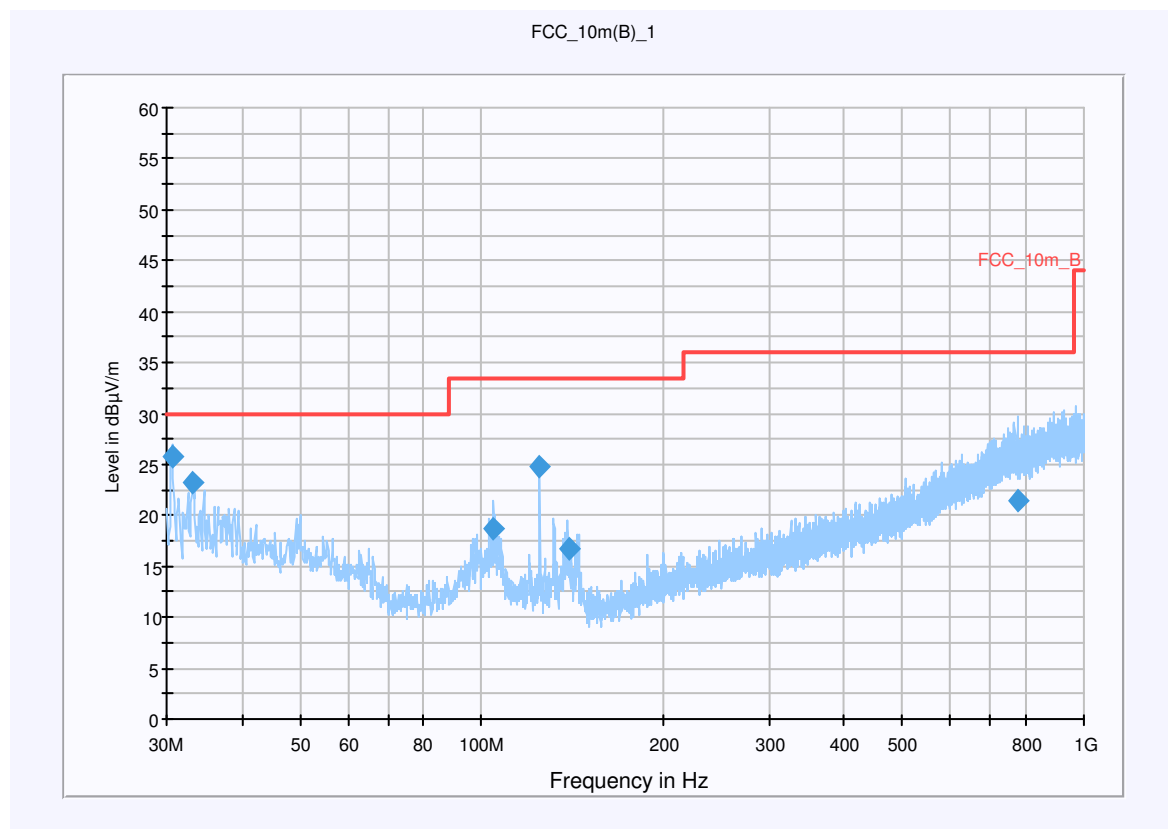

Final Result 1

Frequency (MHz)	QuasiPeak (dBµV/m)	Meas. Time (ms)	Bandwidth (kHz)	Antenna height (cm)	Polarity	Turntable position (deg)	Corr. (dB)	Margin (dB)	Limit (dBµV/m)	Comment
30.618850	25.8	15000.000	120.000	100.0	V	136.0	12.7	4.2	30.0	
33.180750	23.2	15000.000	120.000	100.0	V	306.0	13.0	6.8	30.0	
104.786300	18.7	15000.000	120.000	265.0	V	40.0	11.8	14.8	33.5	
125.004000	24.7	15000.000	120.000	132.0	V	125.0	10.1	8.8	33.5	
139.281250	16.8	15000.000	120.000	120.0	V	35.0	8.9	16.8	33.5	
778.648950	21.4	15000.000	120.000	100.0	V	143.0	24.2	14.6	36.0	

Hardware Setup: EMI radiated\Electric Field (NOS) - [EMI radiated]

Subrange 1	
Frequency Range:	30MHz - 2GHz
Receiver:	Receiver [ESCI 3] @ GPIB0 (ADR 20), SN 100083/003, FW 3.32, CAL 07.01.2009
Signal Path:	without Notch FW 1.0
Antenna:	VULB 9163 SN 9163-295, FW ---, CAL 08.04.2010 Correction Table (vertical): VULP6113 Correction Table (horizontal): VULP6113 Correction Table: Cabel with switch (0408)
Antenna Tower:	Tower [EMCO 2090 Antenna Tower] @ GPIB0 (ADR 8), FW REV 3.12
Turntable:	Turntable [EMCO Turntable] @ GPIB0 (ADR 9), FW REV 3.12

Plot 8: 1 GHz - 12 GHz, channel 40, high data rate, vertical polarisation

CETECOM ICT Services GmbH

Projekt- Nr.:1-0685-01-17_08-2

EUT:	MMS + WLAN Module	Polarisation:	Vertikal
Manufacturer:	Philips	Battery:	AC/DC Power Supply
IMEI:		HW:	
Operator:	BTL	SW:	
Start of Test :	13.02.2009 10:10:13	Vmin:	5
Standard:	FCC_15_407_5000	Vnom:	5
Signalling Unit:	CMU200	Vmax:	5
Transducer-File:	C:\Spurious_neu\Messparameter\FCC_15_407_5000\Transducer_FCC_15_407_5000.xls		
Start Freq. [MHz]:	1000	Stop Freq. [MHz]	12000

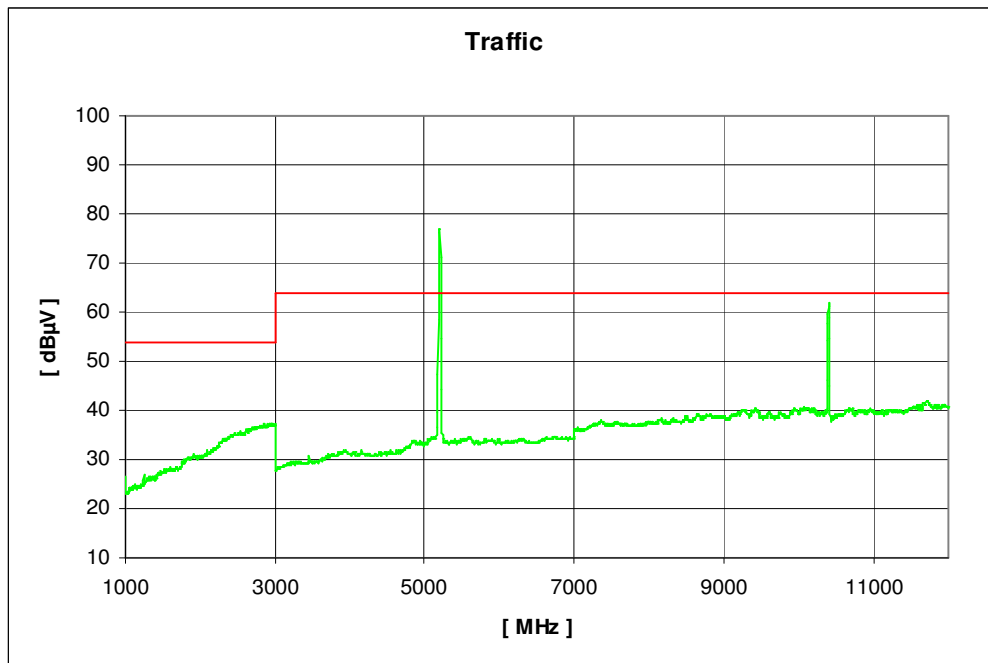

Plot 9: 1 GHz - 12 GHz, channel 40, high data rate, horizontal polarisation

CETECOM ICT Services GmbH

Projekt- Nr.:1-0685-01-17_08-2

EUT:	MMS + WLAN Module	Polarisation:	Horizontal
Manufacturer:	Philips	Battery:	AC/DC Power Supply
IMEI:		HW:	
Operator:	BTL	SW:	
Start of Test :	13.02.2009 13:17:06	Vmin:	5
Standard:	FCC_15_407_5000	Vnom:	5
Signalling Unit:	CMU200	Vmax:	5
Transducer-File:	C:\Spurious_neu\Messparameter\FCC_15_407_5000\Transducer_FCC_15_407_5000.xls		
Start Freq. [MHz]:	1000	Stop Freq. [MHz]	12000

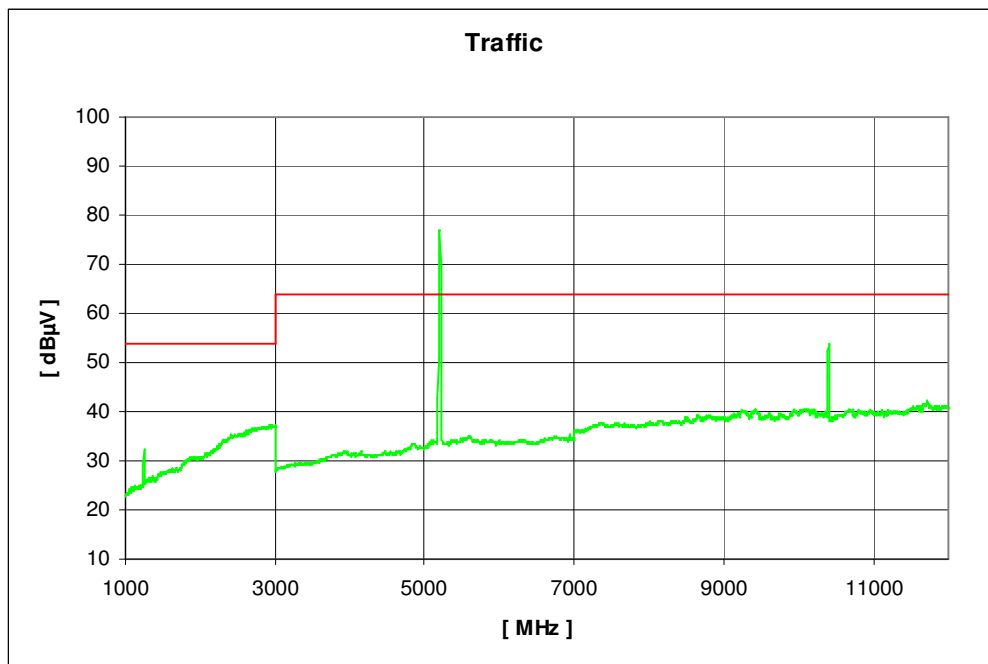

Plot 10: 0.03 - 1 GHz, channel 48, high data rate, vertical / horizontal polarisation

Common Information

EUT: Philips Medizin MMS + WLAN a/b/g/ Modul
 Serial Number:
 Test Description: FCC part 15.407
 Operating Conditions: Wlan Mode A; 54 Mbits; Ch 5.240 GHz; Output Power = 11
 Operator Name: ZAK
 Comment: Powered with DC 5 V

Scan Setup: FCC_Fin [EMI radiated]

Hardware Setup: Electric Field (NOS)
 Level Unit: dBµV/m

Subrange	Detectors	IF Bandwidth	Meas. Time	Receiver
30 MHz - 1 GHz	QuasiPeak	120 kHz	15 s	Receiver

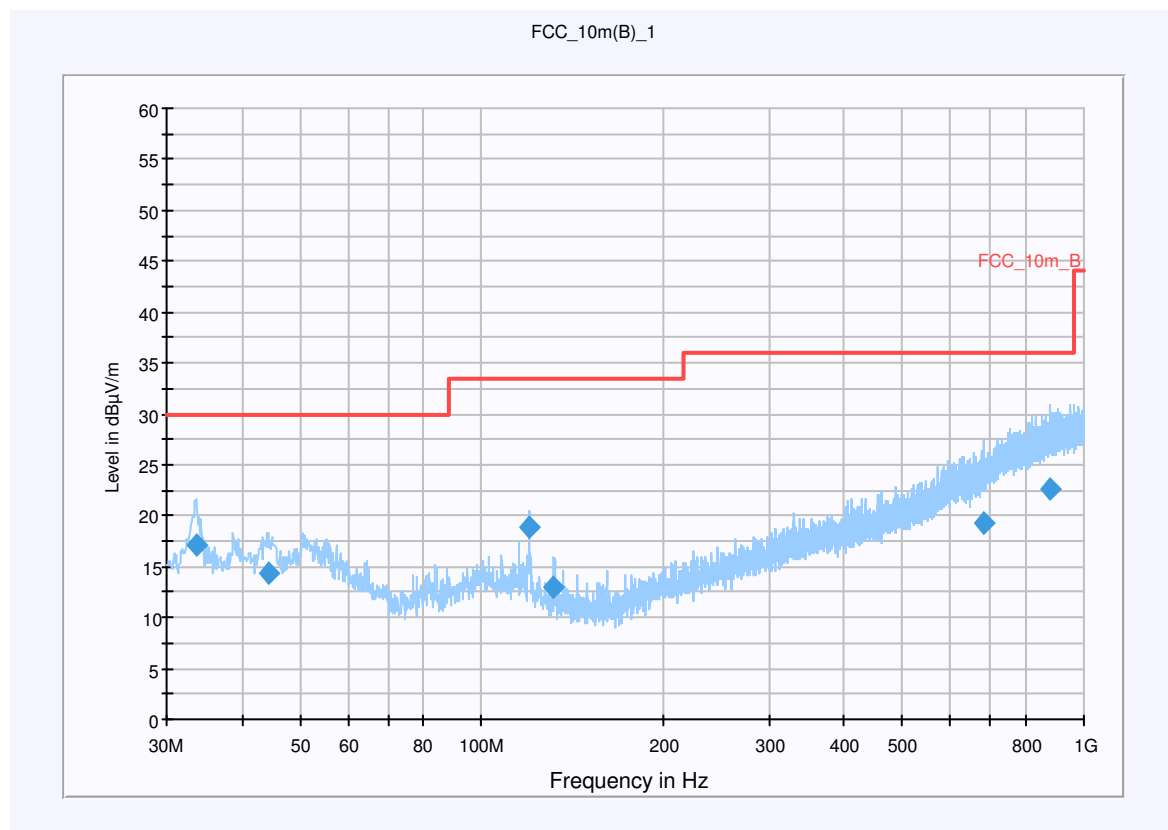

Final Result 1

Frequency (MHz)	QuasiPeak (dBµV/m)	Meas. Time (ms)	Bandwidth (kHz)	Antenna height (cm)	Polarity	Turntable position (deg)	Corr. (dB)	Margin (dB)	Limit (dBµV/m)	Comment
33.658050	17.2	15000.000	120.000	124.0	V	50.0	13.0	12.8	30.0	
44.449800	14.4	15000.000	120.000	158.0	V	194.0	13.4	15.6	30.0	
120.114150	18.9	15000.000	120.000	164.0	V	91.0	10.5	14.6	33.5	
131.935800	13.0	15000.000	120.000	184.0	V	17.0	9.5	20.5	33.5	
683.472350	19.3	15000.000	120.000	379.0	V	267.0	22.1	16.7	36.0	
877.813900	22.7	15000.000	120.000	394.0	V	194.0	25.5	13.3	36.0	

Hardware Setup: EMI radiated\Electric Field (NOS) - [EMI radiated]

Subrange 1	
Frequency Range:	30MHz - 2GHz
Receiver:	Receiver [ESCI 3] @ GPIB0 (ADR 20), SN 100083/003, FW 3.32, CAL 07.01.2009
Signal Path:	without Notch FW 1.0
Antenna:	VULB 9163 SN 9163-295, FW ---, CAL 08.04.2010 Correction Table (vertical): VULP6113 Correction Table (horizontal): VULP6113 Correction Table: Cabel with switch (0408)
Antenna Tower:	Tower [EMCO 2090 Antenna Tower] @ GPIB0 (ADR 8), FW REV 3.12
Turntable:	Turntable [EMCO Turntable] @ GPIB0 (ADR 9), FW REV 3.12

Plot 11: 1 GHz - 12 GHz, channel 48, high data rate, vertical polarisation

CETECOM ICT Services GmbH

Projekt- Nr.:1-0685-01-17_08-2

EUT:	MMS + WLAN Module	Polarisation:	Vertikal
Manufacturer:	Philips	Battery:	AC/DC Power Supply
IMEI:		HW:	
Operator:	BTL	SW:	
Start of Test :	13.02.2009 10:41:37	Vmin:	5
Standard:	FCC_15_407_5000	Vnom:	5
Signalling Unit:	CMU200	Vmax:	5
Transducer-File:	C:\Spurious_neu\Messparameter\FCC_15_407_5000\Transducer_FCC_15_407_5000.xls		

Start Freq. [MHz]:	1000	Stop Freq. [MHz]	12000
--------------------	------	------------------	-------

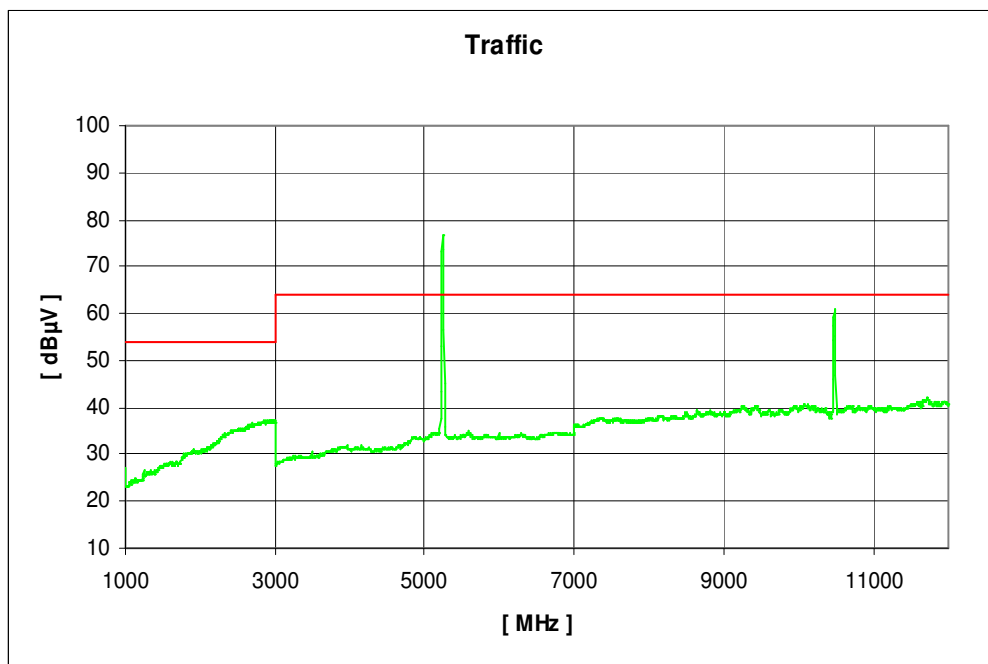

Plot 12: 1 GHz - 12 GHz, channel 48, high data rate, horizontal polarisation

CETECOM ICT Services GmbH

Projekt- Nr.:1-0685-01-17_08-2

EUT:	MMS + WLAN	Polarisation:	Horizontal
Manufacturer:	Module Philips	Battery:	AC/DC Power Supply
IMEI:		HW:	
Operator:	BTL	SW:	
Start of Test :	13.02.2009 13:06:08	Vmin:	5
Standard:	FCC_15_407_5000	Vnom:	5
Signalling Unit:	CMU200	Vmax:	5
Transducer-File:	C:\Spurious_neu\Messparameter\FCC_15_407_5000\Transducer_FCC_15_407_5000.xls		
Start Freq. [MHz]:	1000	Stop Freq. [MHz]	12000

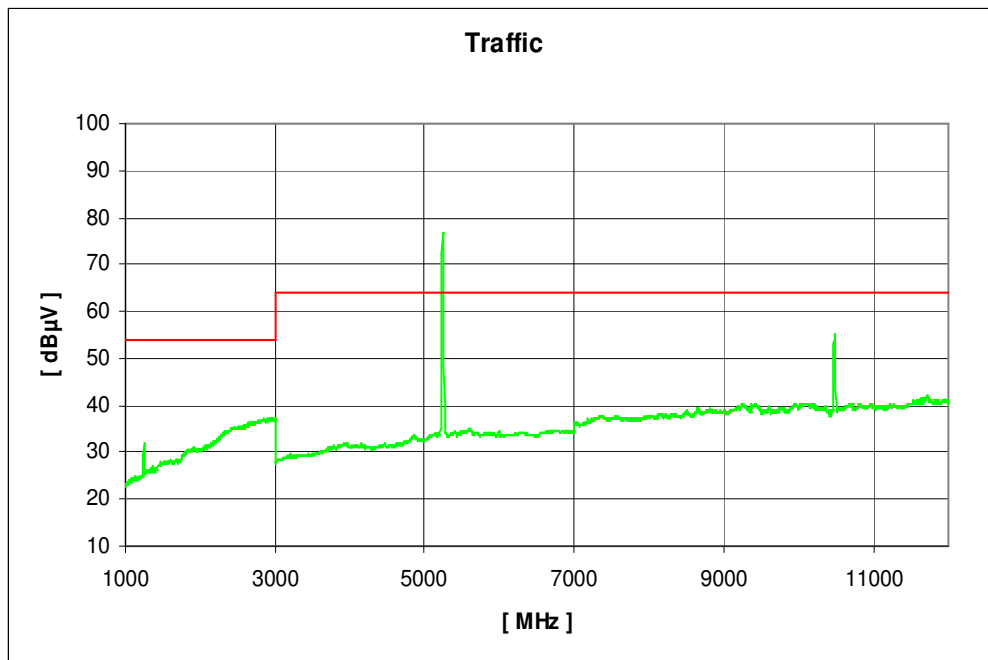

Plot 13: 0.03 - 1 GHz, channel 52, high data rate, vertical / horizontal polarisation

Common Information

EUT: Philips Medizin MMS + WLAN a/b/g/ Modul
 Serial Number:
 Test Description: FCC part 15.407
 Operating Conditions: Wlan Mode A; 54 Mbits; Ch 5.260 GHz; Output Power = 15
 Operator Name: ZAK
 Comment: Powered with DC 5 V

Scan Setup: STAN_Fin [EMI radiated]

Hardware Setup: Electric Field (NOS)
 Level Unit: dBµV/m

Subrange	Detectors	IF Bandwidth	Meas. Time	Receiver
30 MHz - 1 GHz	QuasiPeak	120 kHz	15 s	Receiver

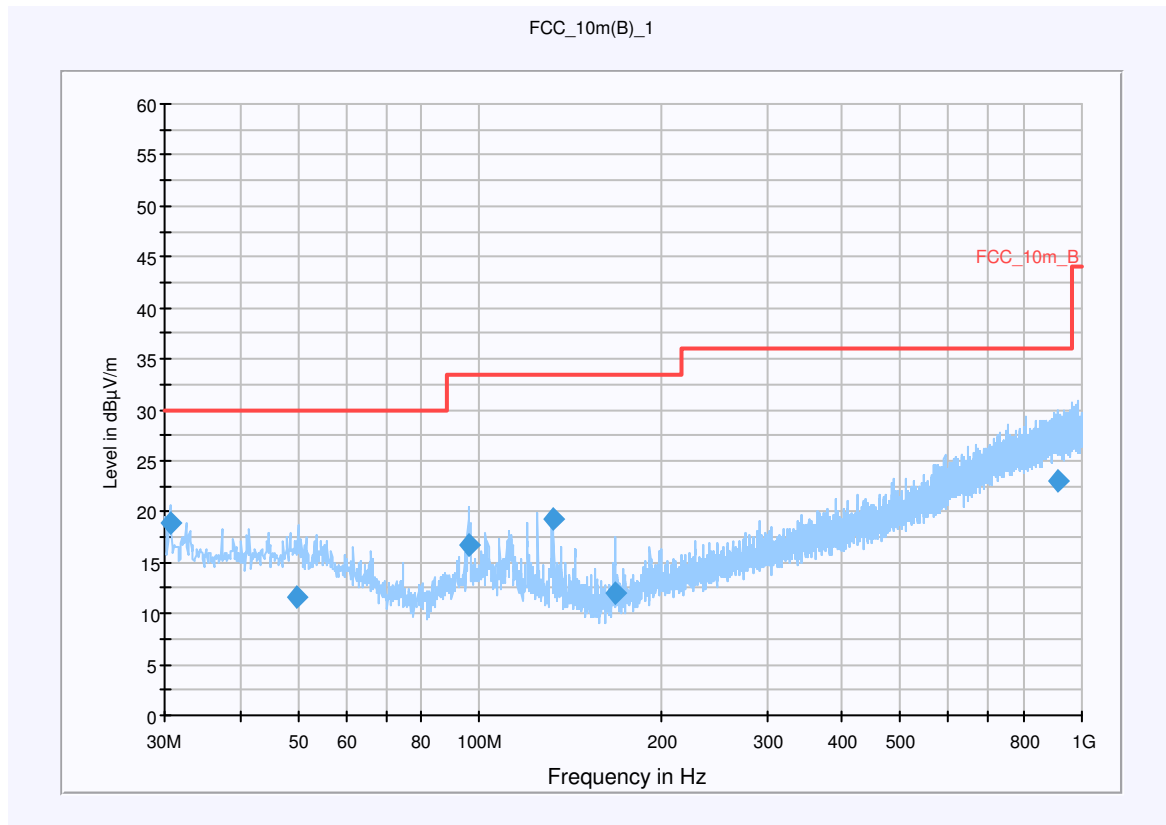

Final Result 1

Frequency (MHz)	QuasiPeak (dBµV/m)	Meas. Time (ms)	Bandwidth (kHz)	Antenna height (cm)	Polarity	Turntable position (deg)	Corr. (dB)	Margin (dB)	Limit (dBµV/m)	Comment
30.616000	18.8	15000.000	120.000	118.0	V	292.0	12.7	11.2	30.0	
49.779150	11.6	15000.000	120.000	137.0	V	143.0	13.5	18.4	30.0	
95.854800	16.7	15000.000	120.000	139.0	V	181.0	11.7	16.8	33.5	
132.050900	19.2	15000.000	120.000	113.0	V	42.0	9.5	14.3	33.5	
168.066050	12.1	15000.000	120.000	200.0	V	89.0	9.9	21.4	33.5	
912.477200	23.0	15000.000	120.000	326.0	V	229.0	25.7	13.0	36.0	

Hardware Setup: EMI radiated\Electric Field (NOS) - [EMI radiated]

Subrange 1	
Frequency Range:	30MHz - 2GHz
Receiver:	Receiver [ESCI 3] @ GPIB0 (ADR 20), SN 100083/003, FW 3.32, CAL 07.01.2009
Signal Path:	without Notch FW 1.0
Antenna:	VULB 9163 SN 9163-295, FW ---, CAL 08.04.2010 Correction Table (vertical): VULP6113 Correction Table (horizontal): VULP6113 Correction Table: Cabel with switch (0408)
Antenna Tower:	Tower [EMCO 2090 Antenna Tower] @ GPIB0 (ADR 8), FW REV 3.12
Turntable:	Turntable [EMCO Turntable] @ GPIB0 (ADR 9), FW REV 3.12

Plot 14: 1 GHz - 12 GHz, channel 52, high data rate, vertical polarisation

CETECOM ICT Services GmbH

Projekt- Nr.:1-0685-01-17_08-2

EUT:	MMS + WLAN Module	Polarisation:	Vertikal
Manufacturer:	Philips	Battery:	AC/DC Power Supply
IMEI:		HW:	
Operator:	BTL	SW:	
Start of Test :	13.02.2009 10:48:48	Vmin:	5
Standard:	FCC_15_407_5000	Vnom:	5
Signalling Unit:	CMU200	Vmax:	5
Transducer-File:	C:\Spurious_neu\Messparameter\FCC_15_407_5000\Transducer_FCC_15_407_5000.xls		
Start Freq. [MHz]:	1000	Stop Freq. [MHz]	12000

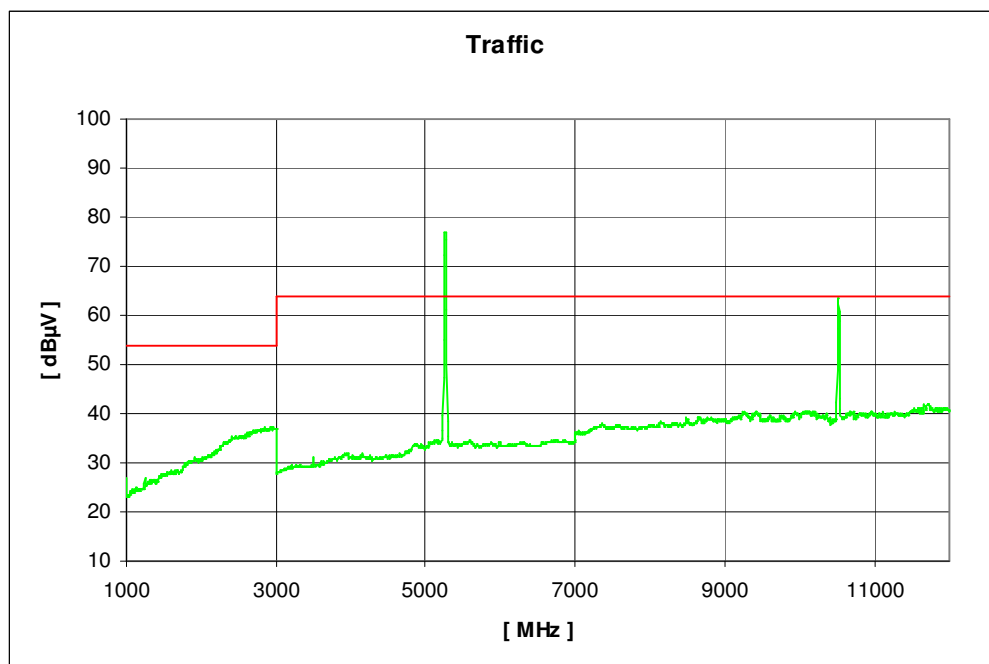

Plot 15: 1 GHz - 12 GHz, channel 52, high data rate, horizontal polarisation

CETECOM ICT Services GmbH

Projekt- Nr.:1-0685-01-17_08-2

EUT:	MMS + WLAN	Polarisation:	Horizontal
Manufacturer:	Module Philips	Battery:	AC/DC Power Supply
IMEI:		HW:	
Operator:	BTL	SW:	
Start of Test :	13.02.2009 12:04:05	Vmin:	5
Standard:	FCC_15_407_5000	Vnom:	5
Signalling Unit:	CMU200	Vmax:	5
Transducer-File:	C:\Spurious_neu\Messparameter\FCC_15_407_5000\Transducer_FCC_15_407_5000.xls		
Start Freq. [MHz]:	1000	Stop Freq. [MHz]	12000

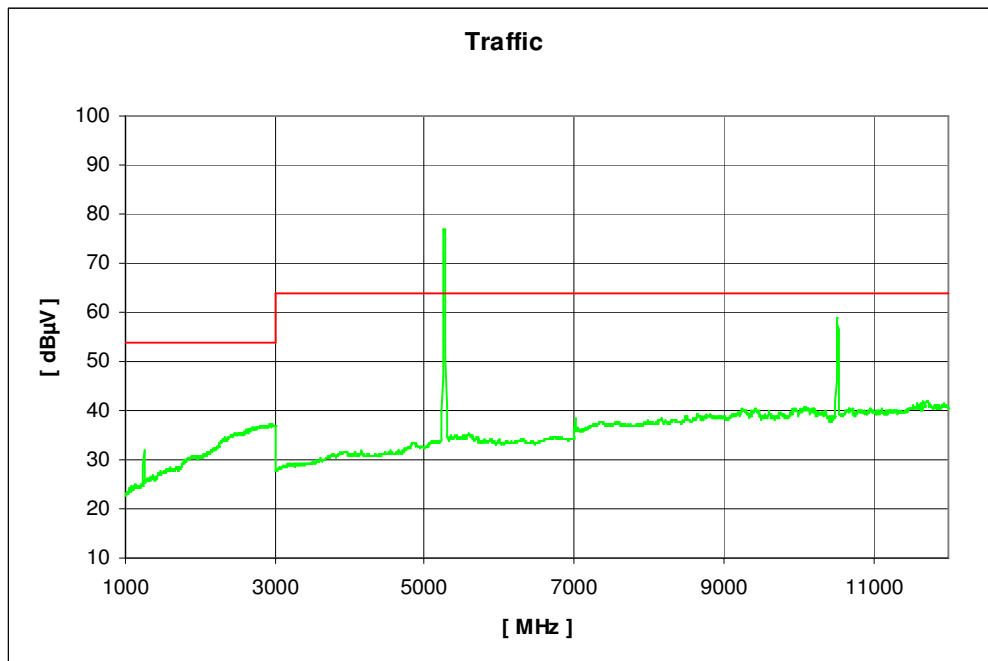

SRD-Testreport

CETECOM ICT Services GmbH Saarbruecken, Germany



Test report No.: 1-0685-01-17/08

Date: 2009-02-19

Page 70 of 102

Plot 16: 12 - 18 GHz (valid for all three channels and both polarisations)

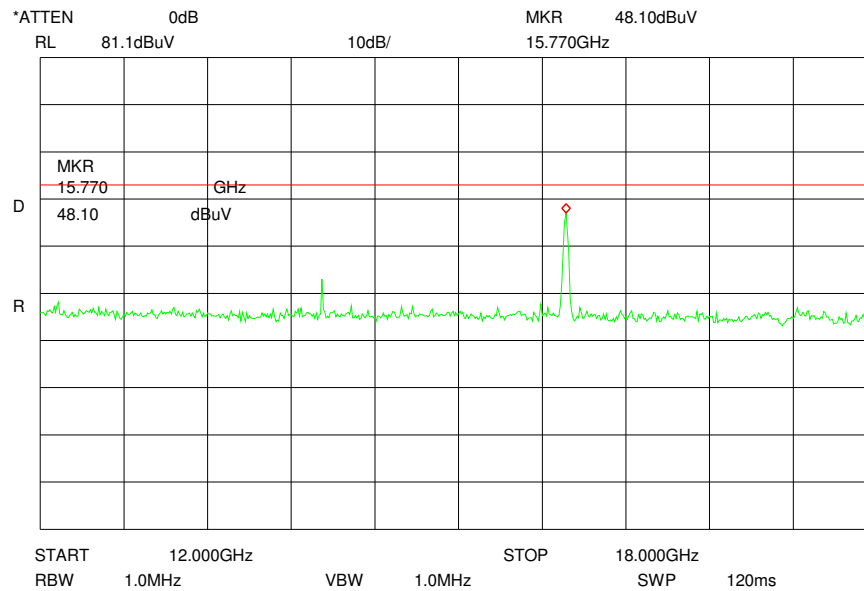

Plot 17: 18 - 26 GHz (valid for all three channels and both polarisations)

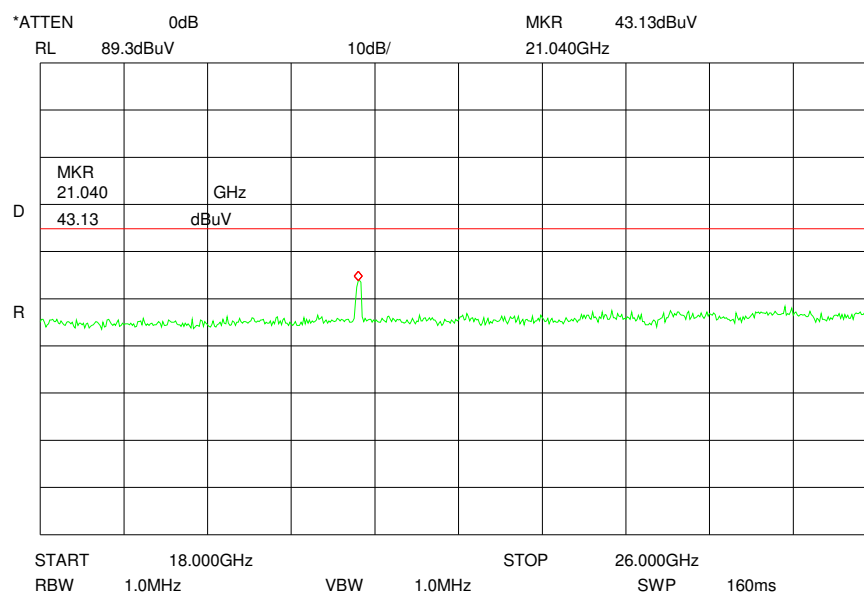

SRD-Testreport

CETECOM ICT Services GmbH Saarbruecken, Germany



Test report No.: 1-0685-01-17/08

Date: 2009-02-19

Page 71 of 102

Plot 18: 26 - 40 GHz (valid for all three channels and both polarisations)

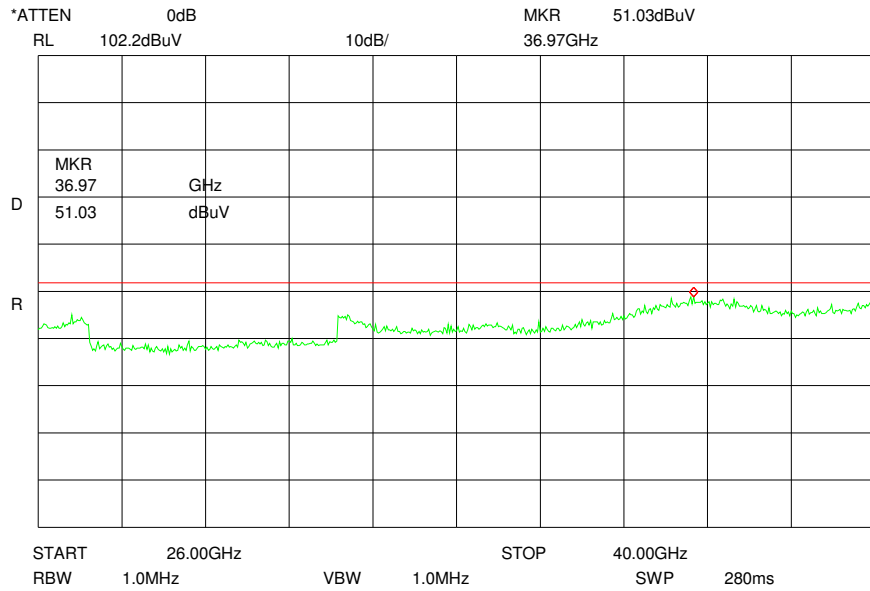

Plot 19: 0.03 - 1 GHz, channel 56, high data rate, vertical / horizontal polarisation

Common Information

EUT: Philips Medizin MMS + WLAN a/b/g/ Modul
 Serial Number: Antenna M8100-66490
 Test Description: FCC part 15.407
 Operating Conditions: Wlan Mode A 54 Mbits; Ch 5.280 Ghz; Output Power = 15
 Operator Name: ZAK
 Comment: Powered with DC 5 V

Scan Setup: FCC_Fin [EMI radiated]

Hardware Setup: Electric Field (NOS)
 Level Unit: dBµV/m

Subrange	Detectors	IF Bandwidth	Meas. Time	Receiver
30 MHz - 1 GHz	QuasiPeak	120 kHz	15 s	Receiver

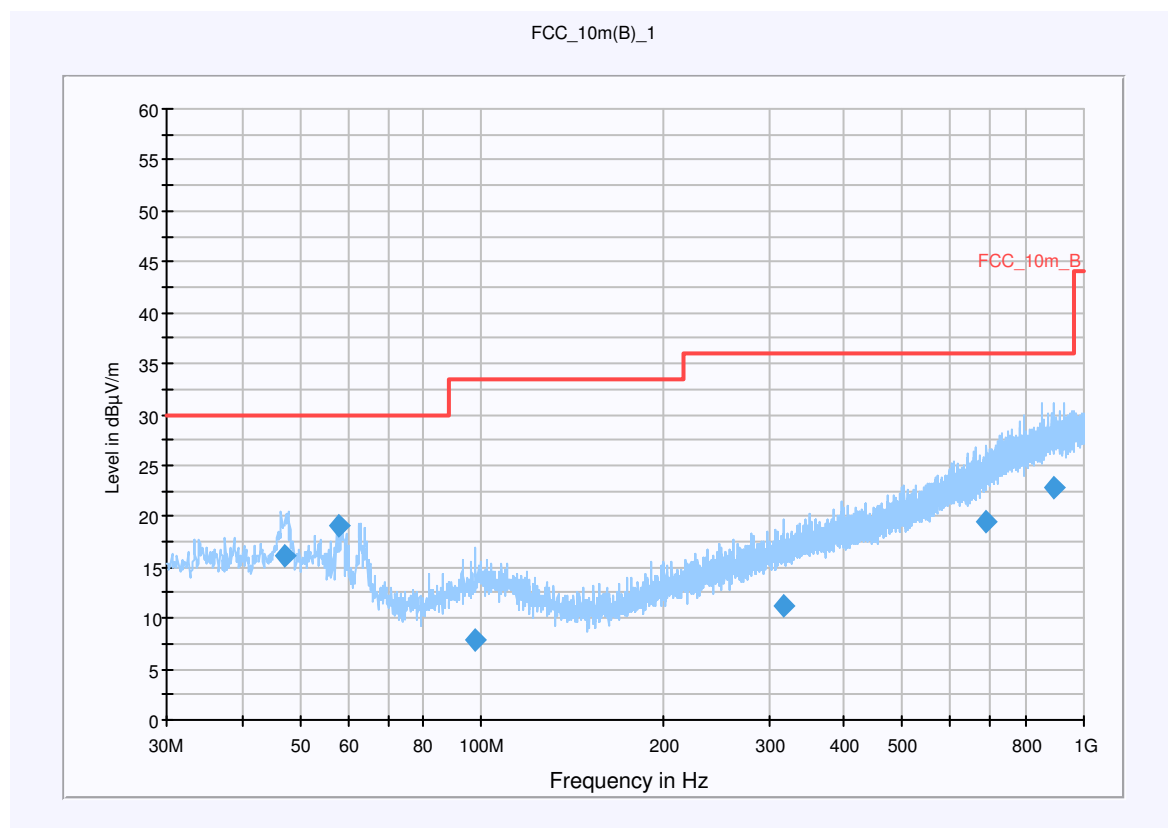

Final Result 1

Frequency (MHz)	QuasiPeak (dBµV/m)	Meas. Time (ms)	Bandwidth (kHz)	Antenna height (cm)	Polarity	Turntable position (deg)	Corr. (dB)	Margin (dB)	Limit (dBµV/m)	Comment
47.022200	16.0	15000.000	120.000	400.0	H	143.0	13.5	14.0	30.0	
58.066850	19.2	15000.000	120.000	160.0	H	50.0	12.3	10.8	30.0	
97.718000	7.9	15000.000	120.000	132.0	H	313.0	12.0	25.6	33.5	
317.276950	11.2	15000.000	120.000	239.0	H	44.0	15.2	24.8	36.0	
689.171650	19.4	15000.000	120.000	187.0	V	22.0	22.3	16.6	36.0	
892.016700	22.8	15000.000	120.000	194.0	V	167.0	25.7	13.2	36.0	

Hardware Setup: EMI radiated\Electric Field (NOS) - [EMI radiated]

Subrange 1	
Frequency Range:	30MHz - 2GHz
Receiver:	Receiver [ESCI 3] @ GPIB0 (ADR 20), SN 100083/003, FW 3.32, CAL 07.01.2009
Signal Path:	without Notch FW 1.0
Antenna:	VULB 9163 SN 9163-295, FW ---, CAL 08.04.2010 Correction Table (vertical): VULP6113 Correction Table (horizontal): VULP6113 Correction Table: Cabel with switch (0408)
Antenna Tower:	Tower [EMCO 2090 Antenna Tower] @ GPIB0 (ADR 8), FW REV 3.12
Turntable:	Turntable [EMCO Turntable] @ GPIB0 (ADR 9), FW REV 3.12

Plot 20: 1 GHz - 12 GHz, channel 56, high data rate, vertical polarisation

CETECOM ICT Services GmbH

Projekt- Nr.:1-0685-01-17_08-2

EUT:	MMS + WLAN Module	Polarisation:	Vertikal
Manufacturer:	Philips	Battery:	AC/DC Power Supply
IMEI:		HW:	
Operator:	BTL	SW:	
Start of Test :	13.02.2009 11:09:49	Vmin:	5
Standard:	FCC_15_407_5000	Vnom:	5
Signalling Unit:	CMU200	Vmax:	5
Transducer-File:	C:\Spurious_neu\Messparameter\FCC_15_407_5000\Transducer_FCC_15_407_5000.xls		
Start Freq. [MHz]:	1000	Stop Freq. [MHz]	12000

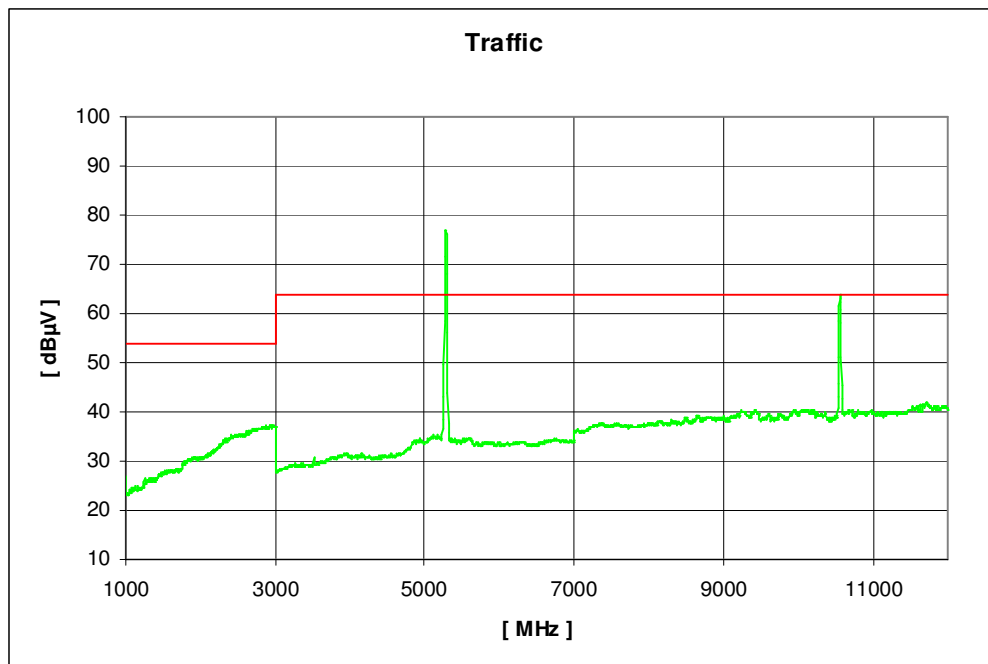

Plot 21: 1 GHz - 12 GHz, channel 56, high data rate, horizontal polarisation

CETECOM ICT Services GmbH

Projekt- Nr.:1-0685-01-17_08-2

EUT:	MMS + WLAN	Polarisation:	Horizontal
Manufacturer:	Module Philips	Battery:	AC/DC Power Supply
IMEI:		HW:	
Operator:	BTL	SW:	
Start of Test :	13.02.2009 11:46:17	Vmin:	5
Standard:	FCC_15_407_5000	Vnom:	5
Signalling Unit:	CMU200	Vmax:	5
Transducer-File:	C:\Spurious_neu\Messparameter\FCC_15_407_5000\Transducer_FCC_15_407_5000.xls		
Start Freq. [MHz]:	1000	Stop Freq. [MHz]	12000

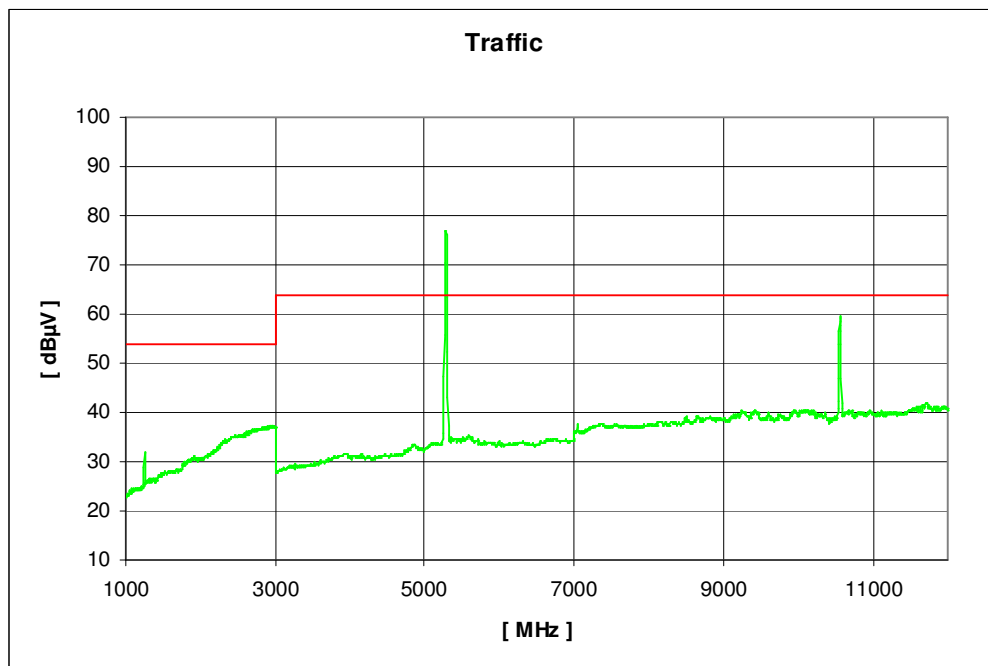

Plot 22: 0.03 - 1 GHz, channel 64, high data rate, vertical / horizontal polarisation

Common Information

EUT: Philips Medizin MMS + WLAN a/b/g/ Modul
 Serial Number:
 Test Description: FCC part 15.407
 Operating Conditions: Wlan Mode A; 54 Mbits; Ch 5.320 Ghz; Output Power = 15
 Operator Name: ZAK
 Comment: Powered with DC 5 V

Scan Setup: FCC_Fin [EMI radiated]

Hardware Setup: Electric Field (NOS)
 Level Unit: dBµV/m

Subrange	Detectors	IF Bandwidth	Meas. Time	Receiver
30 MHz - 1 GHz	QuasiPeak	120 kHz	15 s	Receiver

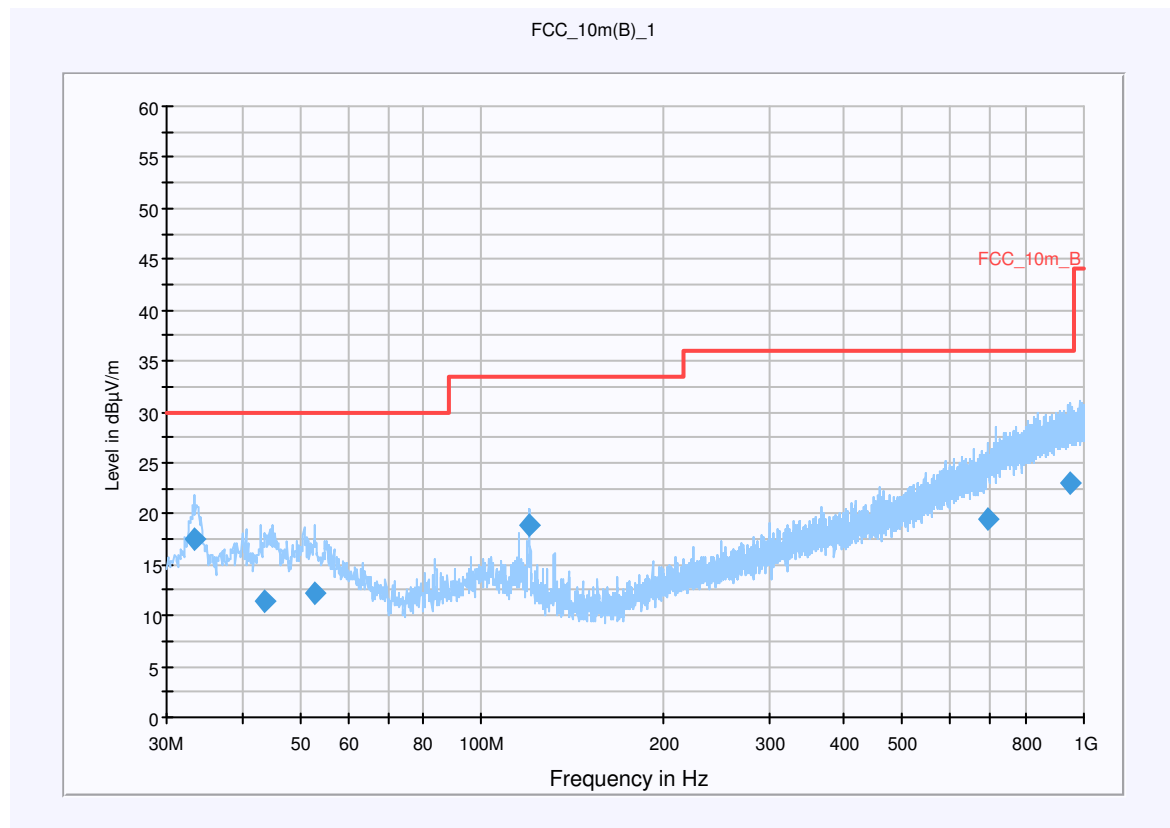

Final Result 1

Frequency (MHz)	QuasiPeak (dBµV/m)	Meas. Time (ms)	Bandwidth (kHz)	Antenna height (cm)	Polarity	Turntable position (deg)	Corr. (dB)	Margin (dB)	Limit (dBµV/m)	Comment
33.510350	17.5	15000.000	120.000	100.0	V	50.0	13.0	12.5	30.0	
43.540000	11.4	15000.000	120.000	148.0	V	13.0	13.5	18.6	30.0	
53.042250	12.3	15000.000	120.000	139.0	V	130.0	13.3	17.7	30.0	
120.105950	18.9	15000.000	120.000	179.0	V	63.0	10.5	14.6	33.5	
691.296700	19.5	15000.000	120.000	331.0	H	192.0	22.4	16.5	36.0	
945.701900	23.0	15000.000	120.000	151.0	V	28.0	25.9	13.0	36.0	

Hardware Setup: EMI radiated\Electric Field (NOS) - [EMI radiated]

Subrange 1	
Frequency Range:	30MHz - 2GHz
Receiver:	Receiver [ESCI 3] @ GPIB0 (ADR 20), SN 100083/003, FW 3.32, CAL 07.01.2009
Signal Path:	without Notch FW 1.0
Antenna:	VULB 9163 SN 9163-295, FW ---, CAL 08.04.2010 Correction Table (vertical): VULP6113 Correction Table (horizontal): VULP6113 Correction Table: Cabel with switch (0408)
Antenna Tower:	Tower [EMCO 2090 Antenna Tower] @ GPIB0 (ADR 8), FW REV 3.12
Turntable:	Turntable [EMCO Turntable] @ GPIB0 (ADR 9), FW REV 3.12

Plot 23: 1 GHz - 12 GHz, channel 64, high data rate, vertical polarisation

CETECOM ICT Services GmbH

Projekt- Nr.:1-0685-01-17_08-2

EUT:	MMS + WLAN Module	Polarisation:	Vertikal
Manufacturer:	Philips	Battery:	AC/DC Power Supply
IMEI:		HW:	
Operator:	BTL	SW:	
Start of Test :	13.02.2009 11:15:18	Vmin:	5
Standard:	FCC_15_407_5000	Vnom:	5
Signalling Unit:	CMU200	Vmax:	5
Transducer-File:	C:\Spurious_neu\Messparameter\FCC_15_407_5000\Transducer_FCC_15_407_5000.xls		
Start Freq. [MHz]:	1000	Stop Freq. [MHz]	12000

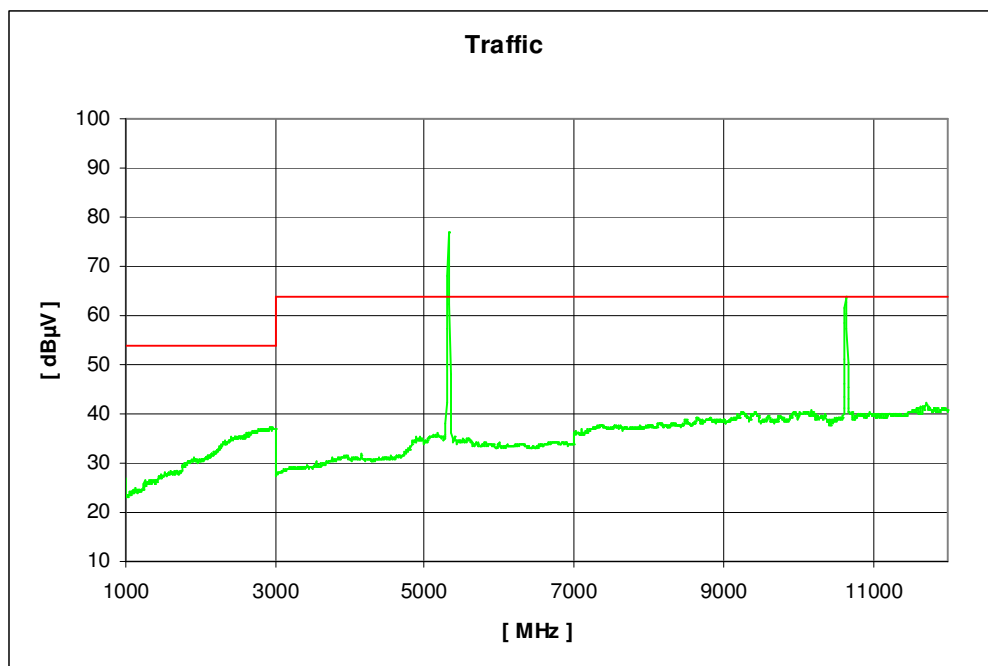

Plot 24: 1 GHz - 12 GHz, channel 64, high data rate, horizontal polarisation

CETECOM ICT Services GmbH

Projekt- Nr.:1-0685-01-17_08-2

EUT:	MMS + WLAN	Polarisation:	Horizontal
Manufacturer:	Module Philips	Battery:	AC/DC Power Supply
IMEI:		HW:	
Operator:	BTL	SW:	
Start of Test :	13.02.2009 11:37:18	Vmin:	5
Standard:	FCC_15_407_5000	Vnom:	5
Signalling Unit:	CMU200	Vmax:	5
Transducer-File:	C:\Spurious_neu\Messparameter\FCC_15_407_5000\Transducer_FCC_15_407_5000.xls		
Start Freq. [MHz]:	1000	Stop Freq. [MHz]	12000

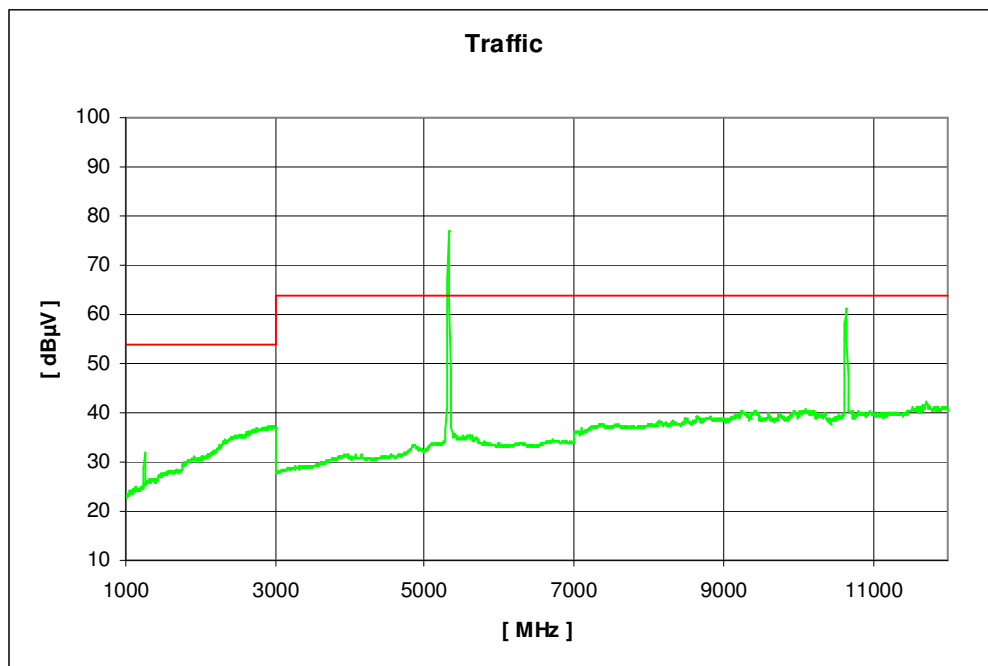

Results:

Spurious Emissions level [$\mu\text{V/m}$]								
Channel 52			Channel 56			Channel 64		
f[GHz]	Detector	Level [$\mu\text{V/m}$]	f[MHz]	Detector	Level [$\mu\text{V/m}$]	f[MHz]	Detector	Level [$\mu\text{V/m}$]
10.52	AV	63.55 @ 1 m	10.56	AV	63.70 @ 1 m	10.64	AV	63.90 @ 1 m
15.77	PP	48.10 @ 37.5 cm 39.58 @ 1 m						
21.04	PP	43.13 @ 37.5 cm 34.61 @ 1 m						
36.97	PP	51.03 @ 37.5 cm 42.51 @ 1 m						
Measurement uncertainty			± 3 dB					

f < 1 GHz: RBW/VBW: 100 kHz
see above plots

f \geq 1GHz: RBW/VBW: 1 MHz

Measurement distance: 1 – 3 GHz = 3m
 3 – 12 GHz = 1m
 12 GHz – 40 GHz = 37.5 cm

Limits :

Under normal test conditions only	See plots
-----------------------------------	-----------

3.14 Spurious emissions radiated (RX)

§ 15.209

Plot 1: 30 to 1000 MHz

Common Information

EUT: Philips Medizin MMS + WLAN a/b/g/ Modul
 Serial Number:
 Test Description: FCC part 15.247
 Operating Conditions: Wlan Rx Mode ; 5 GHz
 Operator Name: ZAK
 Comment: Powered with DC 5 V

Scan Setup: FCC_Fin [EMI radiated]

Hardware Setup: Electric Field (NOS)
 Level Unit: dBµV/m

Subrange	Detectors	IF Bandwidth	Meas. Time	Receiver
30 MHz - 1 GHz	QuasiPeak	120 kHz	15 s	Receiver

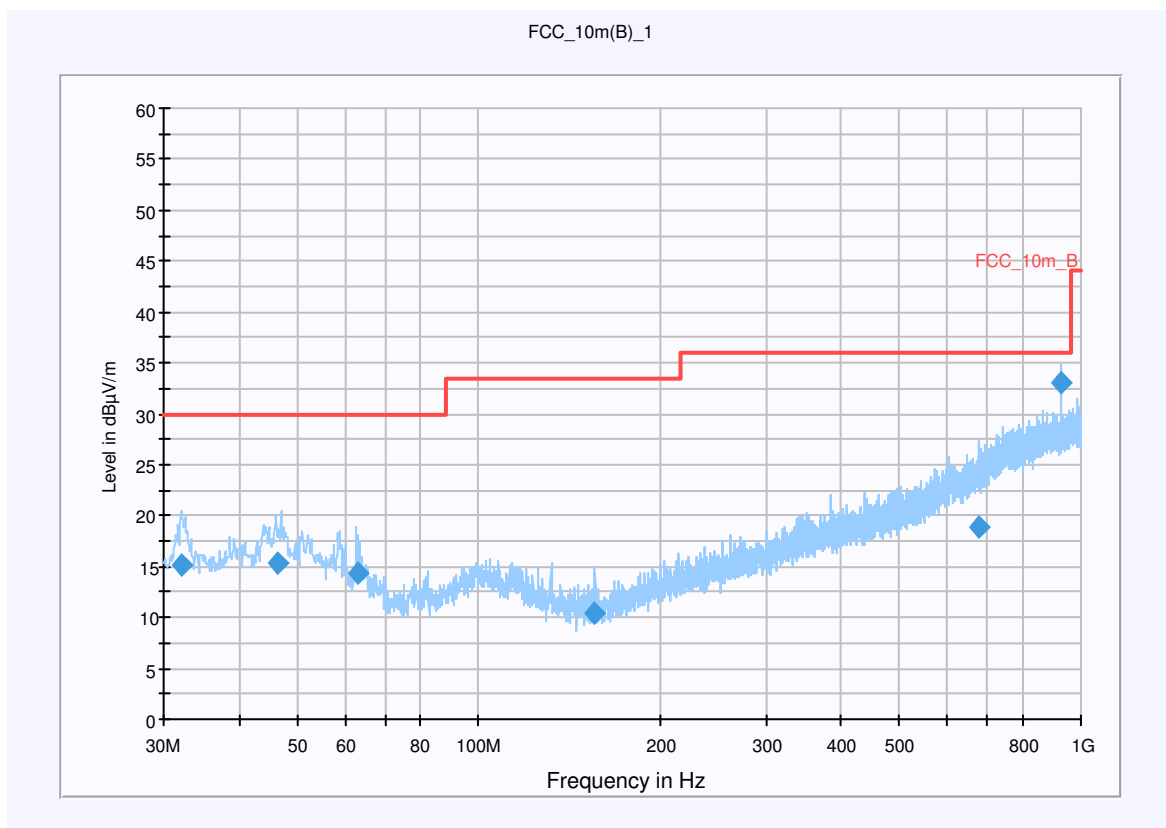

Final Result 1

Frequency (MHz)	QuasiPeak (dBµV/m)	Meas. Time (ms)	Bandwidth (kHz)	Antenna height (cm)	Polarity	Turntable position (deg)	Corr. (dB)	Margin (dB)	Limit (dBµV/m)	Comment
32.087650	15.1	15000.000	120.000	175.0	V	143.0	12.8	14.9	30.0	
46.554550	15.4	15000.000	120.000	183.0	V	220.0	13.5	14.6	30.0	
63.092000	14.3	15000.000	120.000	159.0	V	182.0	11.1	15.7	30.0	
155.920300	10.5	15000.000	120.000	135.0	V	269.0	9.3	23.0	33.5	
675.292250	19.0	15000.000	120.000	400.0	H	168.0	21.9	17.0	36.0	
928.629550	33.0	15000.000	120.000	200.0	V	236.0	25.9	3.0	36.0	

Hardware Setup: EMI radiated\Electric Field (NOS) - [EMI radiated]

Subrange 1	
Frequency Range:	30MHz - 2GHz
Receiver:	Receiver [ESCI 3] @ GPIB0 (ADR 20), SN 100083/003, FW 3.32, CAL 07.01.2009
Signal Path:	without Notch FW 1.0
Antenna:	VULB 9163 SN 9163-295, FW ---, CAL 08.04.2010 Correction Table (vertical): VULP6113 Correction Table (horizontal): VULP6113 Correction Table: Cabel with switch (0408)
Antenna Tower:	Tower [EMCO 2090 Antenna Tower] @ GPIB0 (ADR 8), FW REV 3.12
Turntable:	Turntable [EMCO Turntable] @ GPIB0 (ADR 9), FW REV 3.12

Plot 2: 1 GHz - 12 GHz, vertical polarisation

CETECOM ICT Services GmbH

Projekt- Nr.:1-0685-01-17_08-2

EUT:	MMS + WLAN	Polarisation:	Vertikal
Manufacturer:	Module Philips	Battery:	AC/DC Power Supply
IMEI:		HW:	
Operator:	BTL	SW:	
Start of Test :	13.02.2009 13:39:42	Vmin:	5
Standard:	FCC_15_407_5000	Vnom:	5
Signalling Unit:	CMU200	Vmax:	5
Transducer-File:	C:\Spurious_neu\Messparameter\FCC_15_407_5000\Transducer_FCC_15_407_5000.xls		
Start Freq. [MHz]:	1000	Stop Freq. [MHz]	12000

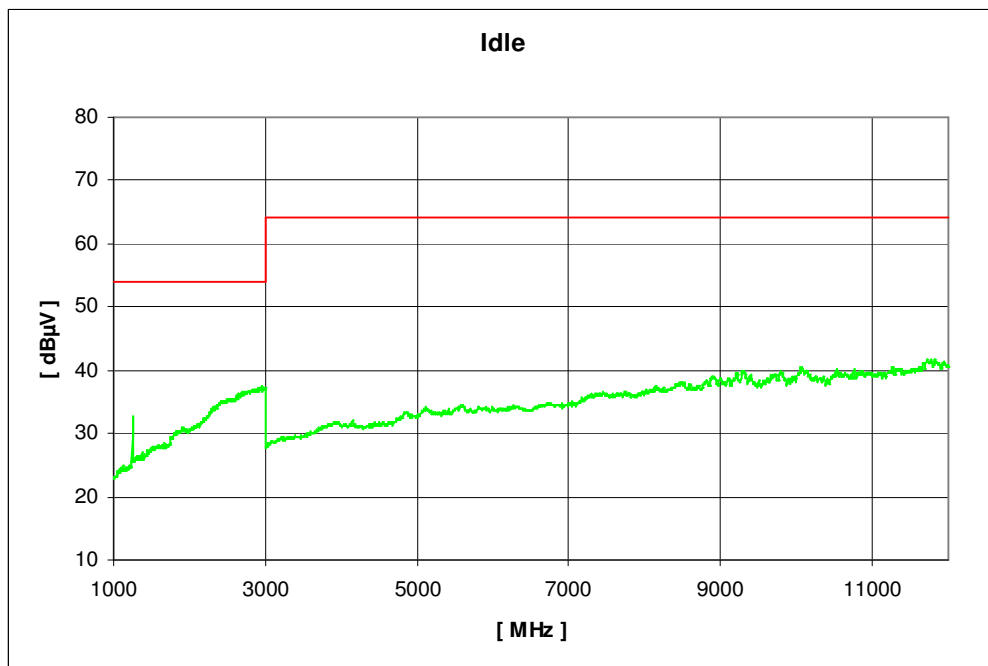

Plot 3: 1 GHz - 12 GHz, horizontal polarisation

CETECOM ICT Services GmbH

Projekt- Nr.:1-0685-01-17_08-2

EUT:	MMS + WLAN	Polarisation:	Horizontal
Manufacturer:	Module Philips	Battery:	AC/DC Power Supply
IMEI:		HW:	
Operator:	BTL	SW:	
Start of Test :	13.02.2009 13:39:42	Vmin:	5
Standard:	FCC_15_407_5000	Vnom:	5
Signalling Unit:	CMU200	Vmax:	5
Transducer-File:	C:\Spurious_neu\Messparameter\FCC_15_407_5000\Transducer_FCC_15_407_5000.xls		
Start Freq. [MHz]:	1000	Stop Freq. [MHz]	12000

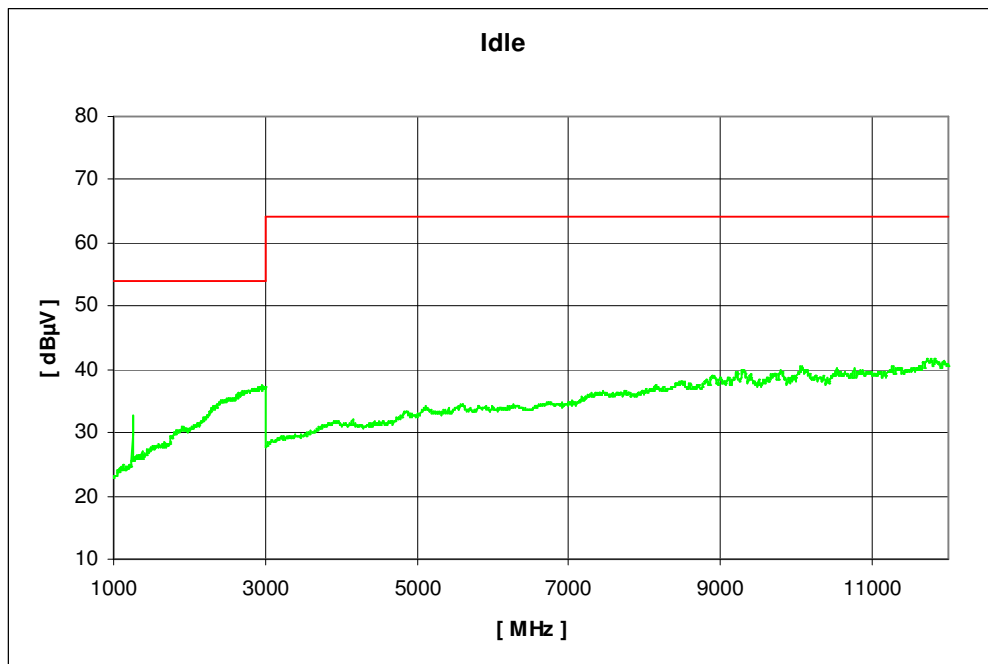

SRD-Testreport

CETECOM ICT Services GmbH Saarbruecken, Germany



Test report No.: 1-0685-01-17/08

Date: 2009-02-19

Page 86 of 102

Plot 4: 12 GHz to 18 GHz

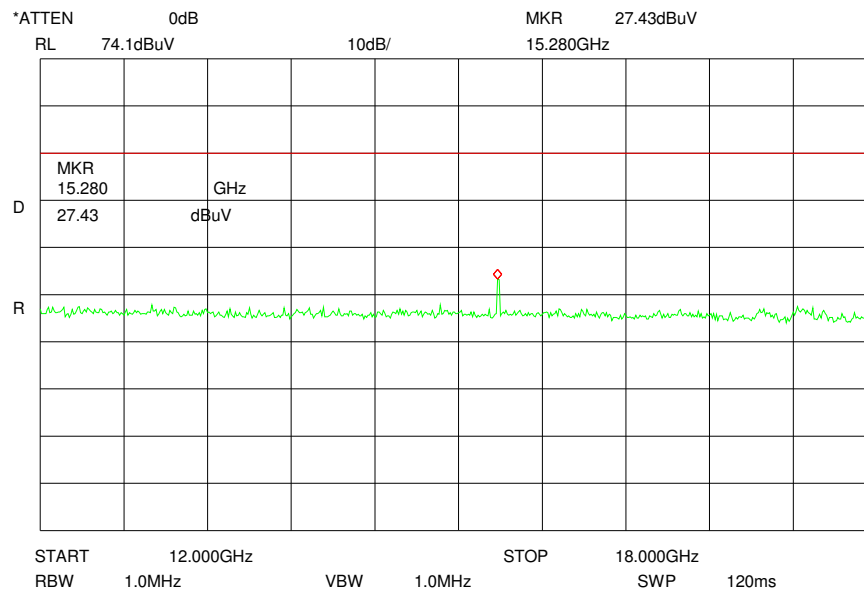

Plot 5: 18 GHz to 26 GHz

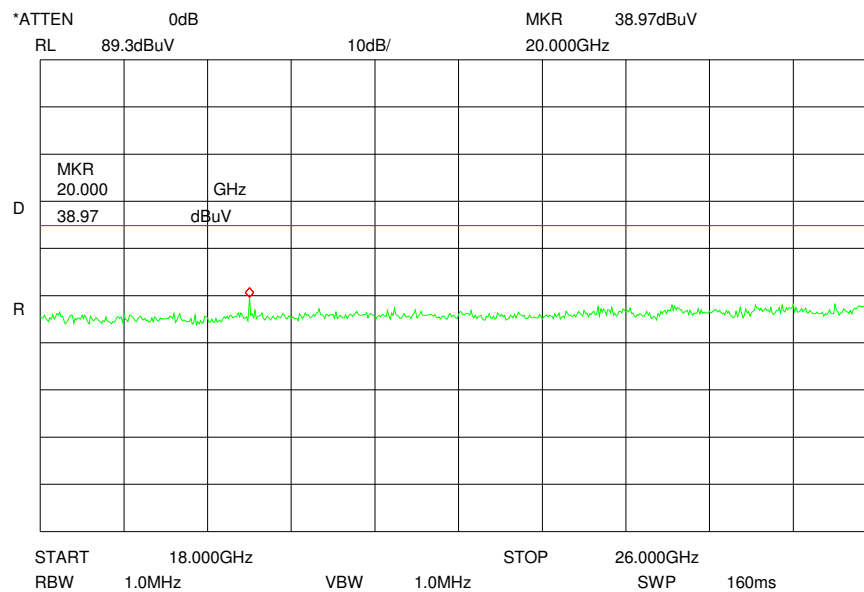

SRD-Testreport

CETECOM ICT Services GmbH Saarbruecken, Germany



Test report No.: 1-0685-01-17/08

Date: 2009-02-19

Page 87 of 102

Plot 6: 26 GHz to 40GHz

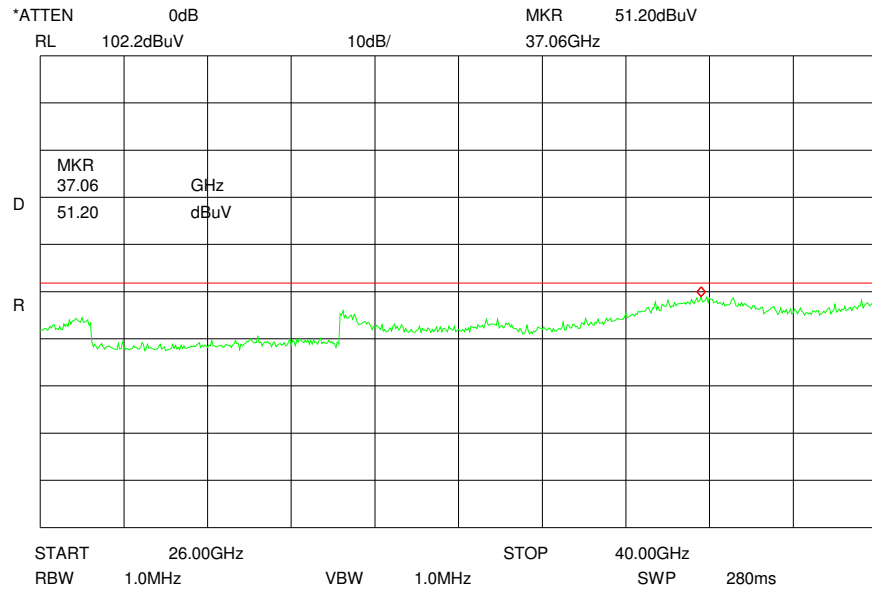

SRD-Testreport

CETECOM ICT Services GmbH Saarbruecken, Germany



Test report No.: 1-0685-01-17/08

Date: 2009-02-19

Page 88 of 102

Results:

Spurious Emissions level [$\mu\text{V/m}$]								
RX / Idle mode			--			--		
f[MHz]	Detector	Level [$\mu\text{V/m}$]	f[MHz]	Detector	Level [$\mu\text{V/m}$]	f[MHz]	Detector	Level [$\mu\text{V/m}$]
No critical peaks detected.								
Measurement uncertainty			± 3 dB					

f < 1 GHz: RBW/VBW: 100 kHz

f \geq 1GHz: RBW/VBW: 1 MHz

see above plots

Limits :

Under normal test conditions only	See plots
-----------------------------------	-----------

3.15 Spurious Emissions - radiated <30 MHz (valid for all antenna types) §15.109

Measured at 3 m distance.

Values recalculated with 40 dB/decade according to FCC rules.

Plot 1: TX mode, First band

CETECOM ICT Services GmbH

Projekt- Nr.:1-0685-01-18_08-2

EUT:	MMS+WLAN Module	Polarisation:	Vertikal
Manufacturer:	Philips	Battery:	AC/DC Power Supply
IMEI:		HW:	
Operator:	BTL	SW:	
Start of Test :	13.02.2009 14:15:42	Vmin:	5
Standard:	FCC_15_209	Vnom:	5
Signalling Unit:		Vmax:	5
Transducer-File:	C:\Spurious_neu\Messparameter\FCC_15_209\Transducer_FCC_15_209.xls		

Start Freq. [MHz]:	0,009	Stop Freq. [MHz]	30
--------------------	-------	------------------	----

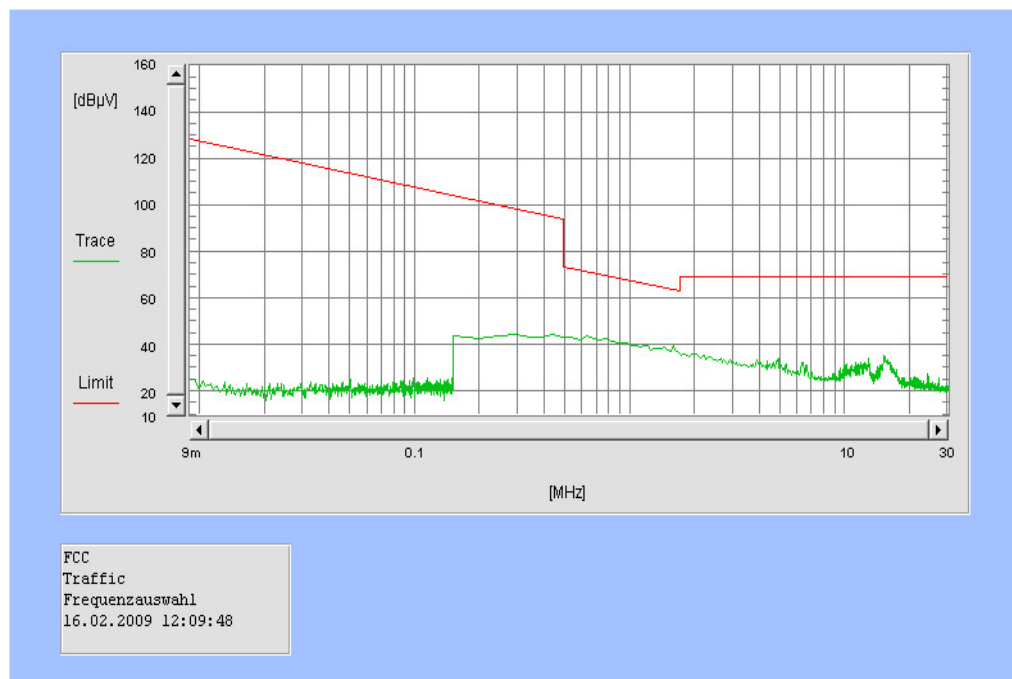

Plot 2: TX mode, Second band

CETECOM ICT Services GmbH

Projekt- Nr.:1-0685-01-18_08-2

EUT:	MMS+WLAN Module	Polarisation:	Vertikal
Manufacturer:	Philips	Battery:	AC/DC Power Supply
IMEI:		HW:	
Operator:	BTL	SW:	
Start of Test :	13.02.2009 14:23:15	Vmin:	5
Standard:	FCC_15_209	Vnom:	5
Signalling Unit:		Vmax:	5
Transducer-File:	C:\Spurious_neu\Messparameter\FCC_15_209\Transducer_FCC_15_209.xls		

Start Freq. [MHz]:	0,009	Stop Freq. [MHz]	30
--------------------	-------	------------------	----

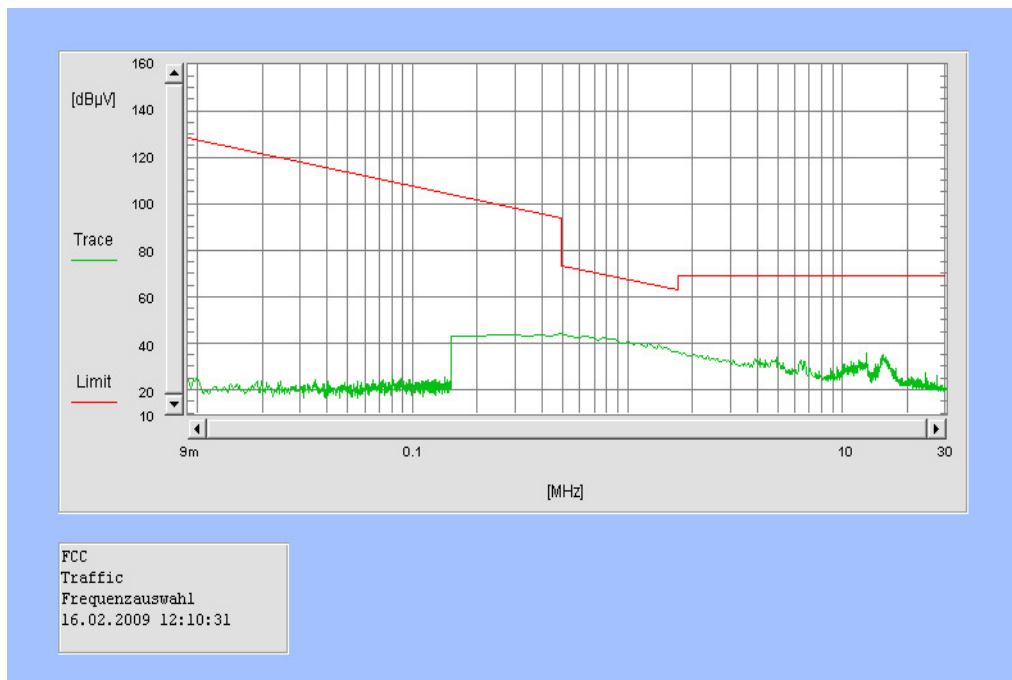

Plot 3: RX mode

CETECOM ICT Services GmbH

Projekt- Nr.:1-0685-01-18_08-2

EUT:	MMS+WLAN Module	Polarisation:	Vertikal
Manufacturer:	Philips	Battery:	AC/DC Power Supply
IMEI:		HW:	
Operator:	BTL	SW:	
Start of Test :	13.02.2009 14:31:29	Vmin:	5
Standard:	FCC_15_209	Vnom:	5
Signalling Unit:	CMU200	Vmax:	5
Transducer-File:	C:\Spurious_neu\Messparameter\FCC_15_209\Transducer_FCC_15_209.xls		

Start Freq. [MHz]:	0,009	Stop Freq. [MHz]	30
--------------------	-------	------------------	----

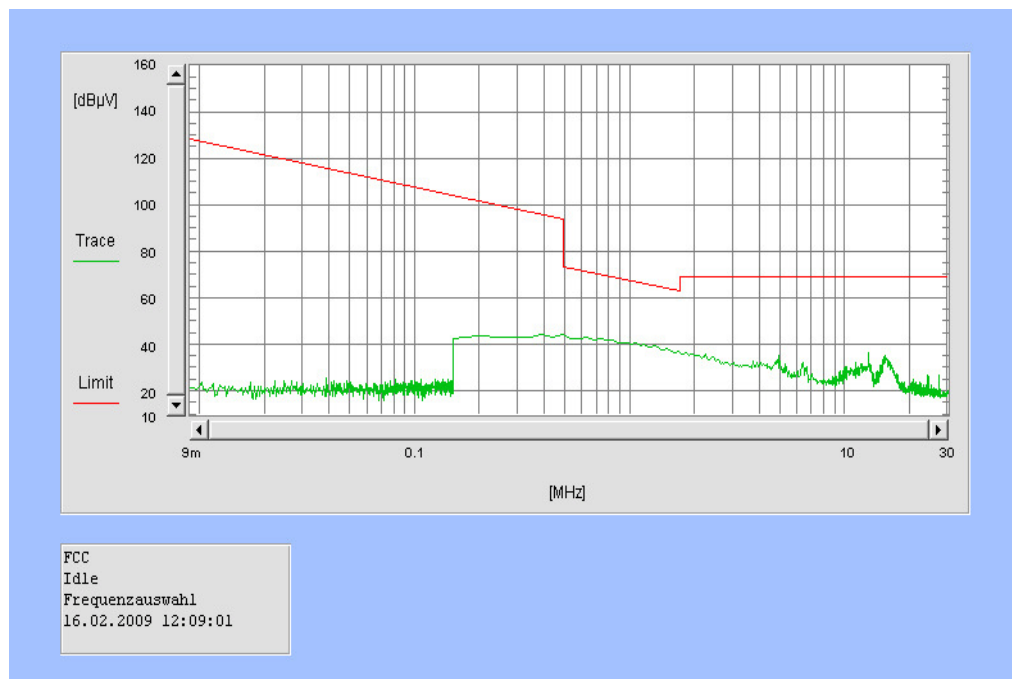

Limits:

Frequency (MHz)	Field strength ($\mu\text{V/m}$)	Measurement distance (m)
0.009 – 0.490	2400/F(kHz)	300
0.490 – 1.705	24000/F(kHz)	30
1.705 – 30.0	30 / 29.5 dB $\mu\text{V/m}$	30
30 - 88	100 / 40 dB $\mu\text{V/m}$	3
88 - 216	150 / 43.5 dB $\mu\text{V/m}$	3
216 - 960	200 / 46 dB $\mu\text{V/m}$	3
above 960	54 dB $\mu\text{V/m}$	3

3.16 Conducted Emissions <30 MHz

§15.107/207

Not performed

Plot 1: Neutral line TX mode

Plot 2: Phase line TX mode

Plot 3: Neutral line RX mode

Plot 4: Phase line RX mode

Limits:

Under normal test conditions only	See plots
-----------------------------------	-----------

3.17 Test equipment

To simplify the identification on each page of the test equipment used, on each page of the test report, each item of test equipment and ancillaries such as cables are identified (numbered) by the Test Laboratory, below.

All reported calibration intervals are calibrations according to the EN/ISO/IEC 17025 standard. These calibrations were performed from an accredited external calibration laboratory.

Additional to these calibrations the laboratory performed comparison measurements with other calibrated systems and performed a weekly chamber inspection.

All used devices are connected with a 10 MHz external reference.

According to the manufacturers' instruction is it possible to establish a calibration interval for the FSP unit of 24 month, if the device has an external 10 MHz reference.

Anechoic chamber C:

No	Equipment/Type	Manuf.	Serial Nr.	Inv. No. Cetecom	Last Calibration	Frequency (months)	Next Calibration
1	Anechoic chamber	MWB	87400/02	300000996	Monthly verification		
2	System-Rack 85900	HP I.V.	*	300000222	n.a.		
3	Measurement System 1						
4	Spektrum Analyzer 8566B	HP	3138A07614	300001207	13.12.2007	24	13.12.2009
5	Spektrum Analyzer Display 85662A	HP	3144A28627	300001208	13.12.2007	24	13.12.2009
6	Quasi-Peak-Adapter 85650A	HP	2811A01204	300002308	13.12.2007	24	13.12.2009
7	RF-Preselector 85685A	HP	2837A00778	300002448	13.12.2007	24	13.12.2009
8	PC Vectra VL	HP		300001688	n.a.		
9	Software EMI	HP		300000983	n.a.		
10	Measurement System 2						
11	FSP 30	R&S	100886	300003575	25.08.2008	24	25.08.2010
12	PC	F+W			n.a.		
13	TILE	TILE			n.a.		
14	Biconical antenna	EMCO	S/N: 860 942/003		Monthly verification (System cal.)		
15	Log. Period. Antenna 3146	EMCO	2130	300001603	Monthly verification (System cal.)		
16	Double Ridged Antenna HP 3115P	EMCO	3088	300001032	Monthly verification (System cal.)		
17	Active Loop Antenna 6502	EMCO	2210	300001015	Monthly verification (System cal.)		
18	Power Supply 6032A	HP	2818A03450	300001040	12.05.2007	36	12.05.2010
19	Busisolator	Kontron		300001056	n.a.		
20	Leitungsteiler 11850C	HP		300000997	Monthly verification (System cal.)		
21	Power attenuator 8325	Byrd	1530	300001595	Monthly verification (System cal.)		
22	Band reject filter WRCG1855/1910	Wainwright	7	300003350	Monthly verification (System cal.)		
23	Band reject filter WRCG2400/2483	Wainwright	11	300003351	Monthly verification (System cal.)		

System Rack Room 005 :

No	Equipment/Type	Manuf.	Serial Nr.	Inv. No. Cetecom	Last Calibration	Frequency (months)	Next Calibration
1	FSP 30	R&S	100886	300003575	25.08.2008	24	25.08.2010
2	CBT	R&S	100313	300003516	03.09.2008	24	03.09.2010
3	Switch Matrix	HP		300000929	n.a.		
4	Power Supply	HP	3041A00544	300002270	13.05.2007	36	13.05.2010
5	Signal Generator	R&S	836206/0092	300002680	30.05.2007	36	30.05.2010

SRD-Testreport

CETECOM ICT Services GmbH Saarbruecken, Germany



Test report No.: 1-0685-01-17/08

Date: 2009-02-19

Page 94 of 102

Signalling Units:

No	Equipment/Type	Manuf.	Serial Nr.	Inv. No. Cetecom	Last Calibration	Frequency (months)	Next Calibration
1	CBT	R&S	100313	300003516	03.09.2008	24	03.09.2010
2	CBT	R&S	100185	300003416	27.08.2008	24	27.08.2010
3	CMU-200	R&S	103992	300003231	04.06.2008	12	04.06.2009
4	CMU-200	R&S	106240	300003321	27.08.2008	24	27.08.2010
5	CMU-200	R&S	832221/0055	300002862	20.03.2008	24	20.03.2010

Climatic Box:

No	Equipment/Type	Manuf.	Serial Nr.	Inv. No. Cetecom	Last Calibration	Frequency (months)	Next Calibration
1	Climatic box VT 4002	Heraeus Vötsch	58566046820010	300003019	11.05.2009	24	11.05.2011
2	Climatic box CTS T-40/50	CTS	064023	300003540	03.01.2009	24	03.01.2011

SRD Laboratory Room 002:

No	Equipment/Type	Manuf.	Serial Nr.	Inv. No. Cetecom	Last Calibration	Frequency (months)	Next Calibration
1	System Controller PSM 12	R&S	835259/007	3000002681-00xx	n.a.		
2	Memory Extension PSM-K10	R&S	To 1	3000002681	n.a.		
3	Operating Software PSM-B2	R&S	To 1	3000002681	n.a.		
4	19" Monitor		22759020-ED	3000002681	n.a.		
5	Mouse		LZE 0095/6639	3000002681	n.a.		
6	Keyboard		G00013834L461	3000002681	n.a.		
7	Spectrum Analyser FSIQ 26	R&S	835540/018	3000002681-0005	10.01.2008	24	10.01.2010
8	Tracking Generator FSIQ-B10	R&S	835107/015	3000002681	s.No.7		
10	RF-Generator SMIQ03 (B1 Signal)	R&S	835541/056	3000002681-0002	26.08.2008	36	26.08.2011
11	Modulation Coder SMIQ-B20	R&S	To 10	3000002681	s.No.10		
12	Data Generator SMIQ-B11	R&S	To 10	3000002681	s.No.10		
13	RF Rear Connection SMIQ-B19	R&S	To 10	3000002681	s.No.10		
14	Fast CPU SM-B50	R&S	To 10	3000002681	s.No.10		
15	FM Modulator SM-B5	R&S	835676/033	3000002681	s.No.10		
16	RF-Generator SMIQ03 (B2 Signal)	R&S	835541/055	3000002681-0001	25.08.2008	36	25.08.2011
17	Modulation Coder SMIQ-B20	R&S	To 16	3000002681	s.No.16		
18	Data Generator SMIQ-B11	R&S	To 16	3000002681	s.No.16		
19	RF Rear Connection SMIQ-B19	R&S	To 16	3000002681	s.No.16		
20	Fast CPU SM-B50	R&S	To 16	3000002681	s.No.16		
21	FM Modulator SM-B5	R&S	836061/022	3000002681	s.No.16		
22	RF-Generator SMP03 (B3 Signal)	R&S	835133/011	3000002681-0003	26.08.2008	36	26.08.2011
23	Attenuator SMP-B15	R&S	835136/014	3000002681	S.No.22		
24	RF Rear Connection SMP-B19	R&S	834745/007	3000002681	S.No.22		
25	Power Meter NRVD	R&S	835430/044	3000002681-0004	26.08.2008	24	26.08.2010
26	Power Sensor NRVD-Z1	R&S	833894/012	3000002681-0013	26.08.2008	24	26.08.2010
27	Power Sensor NRVD-Z1	R&S	833894/011	3000002681-0010	26.08.2008	24	26.08.2010
28	Rubidium Standard RUB	R&S		3000002681-0009	27.08.2008	24	27.08.2010

SRD-Testreport

CETECOM ICT Services GmbH Saarbruecken, Germany



Test report No.: 1-0685-01-17/08

Date: 2009-02-19

Page 95 of 102

29	Switching and Signal Conditioning Unit SSCU	R&S	338864/003	3000002681-0006	01.08.2006	24	01.08.2008
30	Laser Printer HP Deskjet 2100	HP	N/A	3000002681-0011	n.a.		
31	19" Rack	R&S	11138363000004	3000002681	n.a.		
32	RF-cable set	R&S	N/A	3000002681	n.a.		
33	IEEE-cables	R&S	N/A	3000002681	n.a.		
34	Sampling System FSIQ-B70	R&S	835355/009	3000002681	s.No.7		
35	RSP programmable attenuator	R&S	834500/010	3000002681-0007	26.08.2008	24	26.08.2010
36	Signalling Unit	R&S	838312/011	3000002681	n.a.		
37	NGPE programmable Power Supply for EUT	R&S	192.033.41	3000002681			
39	Power Splitter 6005-3	Inmet Corp.	none	300002841	23.12.2008	24	23.12.2010
40	SMA Cables SPS-1151-985-SPS	Insulated Wire	different	different	n.a.		
41	CBT32 with EDR Signaling Unit	R&S					
42	Coupling unit	Narda	N/A	--	n.a.		
43	2xSwitch Matrix PSU	R&S	872584/021	300001329	n.a.		
44	RF-cable set	R&S	N/A	different	n.a.		
45	IEEE-cables	R&S	N/A	--	n.a.		

Note: 3000002681-00xx inventoried as a system

SRD Laboratory Room 005:

No	Equipment/Type	Manuf.	Serial Nr.	Inv. No. Cetecom	Last Calibration	Frequency (months)	Next Calibration
1	Spektrum Analyzer 8566B	HP	2747A05275	300000219	18.01.2008	24	18.01.2010
2	Spektrum Analyzer Display 85662A	HP	2816A16497	300001690	23.01.2008	24	23.01.2010
3	Quasi-Peak-Adapter 85650A	HP	2811A01135	300000216	23.01.2008	24	23.01.2010
4	Power Supply	Heiden	003202	300001187	12.05.2007	36	12.05.2010
5	Power Supply	Heiden	1701	300001392	12.05.2007	36	12.05.2010

SRD Laboratory Room 011:

No	Equipment/Type	Manuf.	Serial Nr.	Inv. No. Cetecom	Last Calibration	Frequency (months)	Next Calibration
1	NRP Power Meter	R&S	100212	300003780	27.02.2008	24	27.02.2010

SRD-Testreport

CETECOM ICT Services GmbH Saarbruecken, Germany



Test report No.: 1-0685-01-17/08

Date: 2009-02-19

Page 96 of 102

Anechoic chamber F:

No	Equipment/Type	Manuf.	Serial Nr.	Inv. No. Cetecom	Last Calibration	Frequency (months)	Next Calibration
1	Control Computer	F+W	FW0502032	300003303	-/-	-/-	-/-
2	Trilog Antenna	9163-295	-/-	-/-	30.04.2008	24	30.04.2010
3	Amplifier - 0518C-138	Veritech Micro-wave Inc.	-/-	-/-	-/-	-/-	-/-
4	Switch - 3488A	HP		300000368	-/-	-/-	-/-
5	EMI Test receiver - ESCI	R&S	100083	300003312	31.01.2009	24	31.01.2011
6	Turntable Controller - 1061 3M	EMCO	1218	300000661	-/-	-/-	-/-
7	Tower Controller 1051 Controller	EMCO	1262	300000625	-/-	-/-	-/-
8	Tower - 1051	EMCO	1262	300000625	-/-	-/-	-/-
10	Ultra Notch-Filter Rejected band Ch. 62	WRCD	9	-/-	-/-	-/-	-/-

Anechoic chamber A:

No.	Instrument/Ancillary	Manufacturer	Type	Serial-No.	Internal identification
Radiated emission in chamber A					
A-1	Spectrum Analyzer	Rohde & Schwarz	ESU26	100037	300003555
A-2	Signal Generator	Rohde & Schwarz	SMR20B11	1104.0002.20	300003593
A-3	RF System Panel	Rohde & Schwarz	TS RSP	---	300003556
A-4	Relais Matrix	Rohde & Schwarz	PSN	860673/009	300001385
A-5	Horn Antenna	EMCO	3115	9709-5290	300000212
A-6	Bilog.-Log. Antenna	Schwarzbeck	VULB 9163	02/00	300003696
A-7	Notch Filter GSM 900	Wainwright	WRCD 901.9/903.1EE	9	---
A-8	Notch Filter GSM 1800	Wainwright	WRCD 1747/1748-5EE	1	---
A-9	Notch Filter GSM 1900	Wainwright	WRCD 1879.5/1880.5EE	9	---
A-10	Notch Filter GSM 850	Wainwright	WRCT 837-0.2/50-8EE	1	---
A-11	Notch Filter UMTS	Wainwright	WRCD 1800/2000-0.2/40-5EEK	2	---
A-12	Notch Filter ISM 2400	Wainwright	WRCD 2400/2483-2375/2505-50/10SS	26	---
A-13	High Pass Filter 1.1 GHz	Wainwright	WHK 1.1/15G-10SS	---	---
A-14	High Pass Filter 2.6 GHz	Wainwright	WHKX 2.6/18G-12SS	---	---
A-15	High Pass Filter 7 GHz	Wainwright	WHKX 7.0/18G-8SS	---	---
A-14	Amplifier	Miteq	AFS4-00201800-15-10P-6	US42-0050 2650-28-5A	300003204
A-16	Controller	Inn co	CO 2000	2020507	---
A-17	DC Power Supply	Hewlet Packard	HP6632A	---	300000924
A-18	Computer	F+W	---	---	300003303