



Instructions for Use

IntelliVue Patient Monitor

MX400/450/500/550/600/700/800

MX400/450/500/550 Release K with Rev. K.1x.xx

MX600/700/800 Release J with Revision J.xx.xx

Patient Monitoring

PHILIPS

Table of Contents

1 Introduction	13
Safety Information	14
Security Information	15
Introducing the Monitor	16
Devices for Acquiring Measurements	18
Operating and Navigating	27
Operating Modes	36
Understanding Screens	37
Connecting Additional Displays to the Monitor	38
Using the XDS Remote Display	39
Using the Visitor Screen	39
Understanding Profiles	39
Understanding Settings	41
Changing Wave Speeds	42
Freezing Waves	42
Using Labels	44
Entering Measurements Manually	46
Changing Monitor Settings	47
Checking Your Monitor Revision	48
Getting Started	48
Disconnecting from Power	49
Networked Monitoring	50
Using the Integrated PC	50
Using Your Monitor with a Monitor in Companion Mode	52
2 What's New?	55
What's New in Release K.1 (for MX400/450/500/550 only)	55
What's New in Release K.0	55
What's New in Release J.0	56
3 Alarms	59
Visual Alarm Indicators	60
Audible Alarm Indicators	61
Acknowledging Alarms	63
Pausing or Switching Off Alarms	64
Alarm Limits	67
Reviewing Alarms	71
Latching Alarms	72
Testing Alarms	73
Alarm Behavior at Power On	73

Alarm Recordings	73
4 Patient Alarms and INOPs	75
<hr/>	
Patient Alarm Messages	75
Technical Alarm Messages (INOPs)	81
5 Managing Patients and Equipment	105
<hr/>	
Patient Concepts	105
Equipment Concepts	105
Managing Patients	106
Managing Equipment	119
Care Groups	126
Information Center Compatibility	132
6 ECG, Arrhythmia, ST and QT Monitoring	133
<hr/>	
Skin Preparation for Electrode Placement	133
Connecting ECG Cables	133
Selecting the Primary and Secondary ECG Leads	134
Checking Paced Mode	134
Understanding the ECG Display	134
Monitoring Paced Patients	135
Changing the Size of the ECG Wave	136
Changing the Volume of the QRS Tone	137
Changing the ECG Filter Settings	137
Selecting Positions of Va and Vb Chest Leads (for 6-lead placement)	138
Choosing EASI or Standard Lead Placement	138
About ECG Leads	138
ECG Lead Fallback	139
ECG Lead Placements	139
EASI ECG Lead Placement	145
Capture 12-Lead	146
ECG and Arrhythmia Alarm Overview	149
Using ECG Alarms	151
ECG Safety Information	152
About Arrhythmia Monitoring	154
Switching Arrhythmia Analysis On and Off	154
Choosing an ECG Lead for Arrhythmia Monitoring	155
Atrial Fibrillation Alarm	155
Aberrantly-Conducted Beats	156
Intermittent Bundle Branch Block	156
Understanding the Arrhythmia Display	156
Arrhythmia Relearning	159
Arrhythmia Alarms	160
About ST Monitoring	164
Switching ST or STE On and Off	165
Understanding the ST Display	166

Updating ST Baseline Snippets	168
Recording ST Segments	168
About the ST Measurement Points	168
ST Alarms	171
STE Alarms	171
Viewing ST Maps	172
About QT/QTc Interval Monitoring	175
QT Alarms	178
Switching QT Monitoring On and Off	179
7 Monitoring Pulse Rate	181
<hr/>	
Entering the Setup Pulse Menu	181
System Pulse Source	181
Switching Pulse On and Off	182
Using Pulse Alarms	182
8 Monitoring Respiration Rate (Resp)	185
<hr/>	
Lead Placement for Monitoring Resp	185
Understanding the Resp Display	186
Changing Resp Detection Modes	186
Changing the Size of the Respiration Wave	187
Changing the Speed of the Respiration Wave	188
Using Resp Alarms	188
Changing the Apnea Alarm Delay	188
Resp Safety Information	188
9 Monitoring SpO2	191
<hr/>	
SpO2 Sensors	191
Applying the Sensor	191
Connecting SpO2 Cables	192
Measuring SpO2	192
SpO2 Signal Quality Indicator (FAST SpO2 only)	193
Assessing a Suspicious SpO2 Reading	194
Changing the Averaging Time	194
Understanding SpO2 Alarms	194
Pleth Wave	200
Perfusion Numeric	200
Perfusion Change Indicator	200
Setting SpO2/Pleth as Pulse Source	200
Setting Up Tone Modulation	201
Setting the QRS Volume	201
Calculating SpO2 Difference	201
10 Monitoring NBP	203
<hr/>	
Introducing the Oscillometric NBP Measurement	203
Preparing to Measure NBP	205

Starting and Stopping Measurements	207
Enabling Automatic Mode and Setting Repetition Time	208
Enabling Sequence Mode and Setting Up The Sequence	208
Choosing the NBP Alarm Source	209
Switching Pulse from NBP On/Off	209
Assisting Venous Puncture	210
Calibrating NBP	210
11 Monitoring Temperature	211
<hr/>	
Making a Temp Measurement	211
Calculating Temp Difference	212
12 Monitoring Invasive Pressure	213
<hr/>	
Setting up the Pressure Measurement	213
Zeroing the Pressure Transducer	215
Adjusting the Calibration Factor	217
Displaying a Mean Pressure Value Only	217
Changing the Pressure Wave Scale	217
Optimizing the Waveform	217
Using the Wave Cursor	217
Non-Physiological Artifact Suppression	218
Choosing the Pressure Alarm Source	218
Calibrating Reusable Transducer CPJ840J6	219
Calculating Cerebral Perfusion Pressure	221
Calculating Pulse Pressure Variation	221
Measuring IAP	222
Measuring Pulmonary Artery Wedge Pressure	222
Editing the Wedge	223
Identifying the Pressure Analog Output Connector	224
13 Monitoring Cardiac Output	225
<hr/>	
Hemodynamic Parameters	226
Using the C.O. Procedure Window	226
Accessing the Setup C.O. and Setup CCO Menus	228
Entering the HemoCalc Window	228
Measuring C. O. Using the PiCCO Method	228
Measuring C.O. Using the Right Heart Thermodilution Method	233
Documenting C.O. Measurements	235
C.O. Injectate Guidelines	235
C.O./CCO Curve Alert Messages	236
C.O./CCO Prompt Messages	238
C.O./CCO Warning Messages	238
C.O./CCO Safety Information	239
14 Monitoring Carbon Dioxide	241
<hr/>	
Measurement Principles	242

Measuring CO2 using M3014A or X2	242
Measuring Mainstream CO2 using M3016A	246
Measuring Microstream CO2 using M3015A/B	248
Setting up all CO2 Measurements	250
Understanding the IPI Numeric	252
15 Monitoring Airway Flow, Volume and Pressure	255
<hr/>	
Attaching the Flow Sensor	256
Zero Calibration	258
Automatic Purging	258
Manual Purging	259
Gas Compensation	259
Setting up Spirometry	260
16 Monitoring tcGas	263
<hr/>	
Identifying tcGas Module Components	263
Setting the tcGas Sensor Temperature	264
Using the tcGas Site Timer	264
Setting the tcGas Barometric Pressure	265
Remembraning the tcGas Transducer	265
Calibrating the tcGas Transducer	265
Applying the tcGas Transducer	267
Finishing tcGas Monitoring	268
Zeroing the tcGas Relative Heat Power	268
TcGas Corrections	268
17 Monitoring Intravascular Oxygen Saturation	271
<hr/>	
Selecting a Measurement Label	272
Preparing to Monitor with the M1021A Wide Module	272
Preparing to Monitor with the M1011A Narrow Module	275
Further Information for Both Modules	277
18 Monitoring EEG	279
<hr/>	
EEG Monitoring Setup	279
Using the EEG Impedance/Montage Window	280
About Compressed Spectral Arrays (CSA)	282
Changing EEG Settings	283
EEG Reports	284
EEG Safety Information	284
EEG and Electrical Interference	284
19 Monitoring BIS	285
<hr/>	
BIS Monitoring Setup	286
BIS Continuous Impedance Check	288
BIS Cyclic Impedance Check	288
BIS Window	289

Changing the BIS Smoothing Rate	290
Switching BIS and Individual Numerics On and Off	290
Changing the Scale of the EEG Wave	290
Switching BIS Filters On or Off	290
BIS Safety Information	291
20 Monitoring NMT	293
<hr/>	
Stimulation Modes	294
Preparing to Measure NMT	295
Taking NMT Measurements	296
Changing the NMT Measurement Settings	298
Alarms	299
Understanding NMT Numerics	299
21 Guardian Early Warning Scoring	301
<hr/>	
Performing the Scoring Procedure	301
Understanding Guardian Early Warning Scoring	303
Viewing EWS Trend Data	304
Using Different Types of Scoring	305
22 Using a Telemetry Device and a Monitor (PIIC only)	307
<hr/>	
How Can You Combine Devices?	307
Use Models With Telemetry	309
23 Trends	311
<hr/>	
Viewing Trends	311
Setting Up Trends	315
Documenting Trends	319
Trends Databases	319
Screen Trends	320
24 Calculations	325
<hr/>	
Viewing Calculations	326
Reviewing Calculations	327
Performing Calculations	327
Entering Values for Calculations	328
Documenting Calculations	329
25 High Resolution Trend Waves	331
<hr/>	
Changing the Hi-Res Trend Waves Displayed	331
Hi-Res Trend Wave Scales	331
Hi-Res Trend Waves and OxyCRG	331
Printing Hi-Res Trend Wave Reports	332
Hi-Res Trend Wave Recordings	332

26 Event Surveillance	333
Levels of Event Surveillance	333
Event Groups	334
Event Episodes	334
Events Pop-Up Keys	335
Event Triggers	336
The Events Database	339
Viewing Events	340
Annotating Events	342
Documenting Events	342
27 ProtocolWatch	349
SSC Sepsis Protocol	349
28 Recording	357
Paper-Strip Recording	357
Electronic Recording	365
29 Printing Patient Reports	369
Starting Report Printouts	369
Stopping Reports Printouts	371
Setting Up Reports	371
Setting Up Individual Print Jobs	372
Checking Printer Settings	373
Printing a Test Report	374
Switching Printers On or Off for Reports	374
Dashed Lines on Reports	374
Unavailable Printer: Re-routing Reports	374
Checking Report Status and Printing Manually	375
Printer Status Messages	375
Sample Report Printouts	376
30 Using the Drug Calculator	381
Accessing the Drug Calculator	382
Performing Drug Calculations	382
Charting Infusion Progress	385
Using the Titration Table	385
Documenting Drug Calculations	386
31 VueLink Modules	387
Connecting an External Device	388
Changing VueLink Waves and Numerics Displayed	388
Viewing the VueLink Device Data Window	389
Using VueLink Screens	389
Switching VueLink On and Off	389
Alarms/INOPs From External Devices	389

Language Conflict with External Device Drivers	390
32 IntelliBridge EC10	391
<hr/>	
Connecting an External Device	391
Changing Waves and Numerics Displayed	392
Viewing the IntelliBridge Device Data Window	392
Using Screens with External Device Data	393
Alarms/INOPs from External Devices	393
33 Using Timers	395
<hr/>	
Viewing Timers	395
Timer Setup Pop-up Keys	396
Setting Up Timers	396
Displaying a Timer On The Main Screen	397
Displaying A Clock On The Main Screen	398
34 Respiratory Loops	399
<hr/>	
Viewing Loops	399
Capturing and Deleting Loops	400
Showing/Hiding Loops	400
Changing Loops Display Size	400
Using the Loops Cursor	400
Changing Loops Type	401
Setting Up Source Device	401
Documenting Loops	401
35 Laboratory Data	403
<hr/>	
Viewing Received Data	403
36 Using Batteries	405
<hr/>	
Battery Power Indicators	405
Checking Battery Charge	407
When Battery Lifetime is Expired	407
Replacing a Battery	407
Optimizing Battery Performance	408
Battery Safety Information	409
37 Care and Cleaning	411
<hr/>	
General Points	411
Cleaning the Equipment	412
Disinfecting the Equipment	412
Sterilizing the Equipment	413
Cleaning, Sterilizing and Disinfecting Monitoring Accessories	413
Cleaning the SO2 Optical Module	413
Cleaning the Recorder Printhead (M1116B only)	413
Cleaning Batteries and the Battery Compartment	414



38 Maintenance and Troubleshooting	415
Inspecting the Equipment and Accessories	415
Inspecting the Cables and Cords	416
Maintenance Task and Test Schedule	416
Troubleshooting	417
Returning Equipment for Repair	417
Disposing of the Monitor	417
Disposing of Empty Calibration Gas Cylinders	418
39 Accessories	419
ECG/Resp Accessories	419
NBP Accessories	423
Invasive Pressure Accessories	426
SpO2 Accessories	429
Temperature Accessories	435
Cardiac Output (C.O.) Accessories	436
Mainstream CO2 Accessories	437
Sidestream CO2 Accessories	437
Mainstream CO2 Accessories (for M3016A)	438
Microstream CO2 Accessories	438
Spirometry Accessories	439
tcGas Accessories	439
EEG Accessories	440
BIS Accessories	440
SO2 Accessories for M1021A	440
SO2 Accessories for M1011A	441
NMT Accessories	441
Recorder Accessories	442
Battery Accessories	442
40 Specifications	443
Indications for Use	443
Restricted Availability	444
Use Environment	444
Manufacturer's Information	444
Symbols	445
Installation Safety Information	447
Monitor Mounting Precautions	455
Altitude Setting	456
Monitor Safety Specifications	456
Physical Specifications	457
Environmental Specifications	458
EMC and Radio Regulatory Compliance	462
Monitor Performance Specifications	464
Interface Specifications	470
Display Specifications	474

M4605A Battery Specifications	475
Measurement Specifications	475
Safety and Performance Tests	495
41 Default Settings Appendix	501
<hr/>	
Country-Specific Default Settings	501
Alarm and Measurement Default Settings	508
Alarm Default Settings	508
ECG, Arrhythmia, ST and QT Default Settings	509
Pulse Default Settings	512
Respiration Default Settings	513
SpO2 Default Settings	513
NBP Default Settings	514
Temperature Default Settings	514
Invasive Pressure Default Settings	515
Cardiac Output Default Settings	517
CO2 Default Settings	518
Spirometry Default Settings	518
tcGas Default Settings	519
Intravascular Oxygen Saturation Default Settings	519
SvO2 Default Settings	520
ScvO2 Default Settings	520
EEG Default Settings	520
BIS Default Settings	521
NMT Default Settings	521
VueLink Default Settings	522
Index	523
<hr/>	

Introduction

These Instructions for Use are for clinical professionals using the IntelliVue MX400/MX450, MX500/MX550, and MX600/MX700/MX800 patient monitor.

This basic operation section gives you an overview of the monitor and its functions. It tells you how to perform tasks that are common to all measurements (such as entering data, switching a measurement on and off, setting up and adjusting wave speeds, working with profiles). The alarms section gives an overview of alarms. The remaining sections tell you how to perform individual measurements, and how to care for and maintain the equipment.

Familiarize yourself with all instructions including warnings and cautions before starting to monitor patients. Read and keep the Instructions for Use that come with any accessories, as these contain important information about care and cleaning that is not repeated here.

This guide describes all features and options. Your monitor may not have all of them; they are not all available in all geographies. Your monitor is highly configurable. What you see on the screen, how the menus appear and so forth, depends on the way it has been tailored for your hospital and may not be exactly as shown here.

In this guide:

- A **warning** alerts you to a potential serious outcome, adverse event or safety hazard. Failure to observe a warning may result in death or serious injury to the user or patient.
- A **caution** alerts you to where special care is necessary for the safe and effective use of the product. Failure to observe a caution may result in minor or moderate personal injury or damage to the product or other property, and possibly in a remote risk of more serious injury.

**MX400/
MX450** Whenever a monitor's identifier appears to the left of a heading or paragraph, it means that the information applies to that monitor only. Where the information applies to all models, no distinction is made.

For installation, repair, testing and troubleshooting instructions, refer to the Service Guide for your monitor model.

Rx only: U.S. Federal Law restricts this device to sale by or on the order of a physician.

Safety Information

The following warnings apply to the monitors in general. Warnings that apply to specific measurements or procedures can be found in the corresponding chapters.

Electrical Hazards and Interference

WARNING

Grounding: To avoid the risk of electric shock, the monitor must be grounded during operation. If a three-wire receptacle is not available, consult the hospital electrician. Never use a three-wire to two-wire adapter.

Electrical shock hazard: Do not open the monitor or measurement device. Contact with exposed electrical components may cause electrical shock. Refer servicing to qualified service personnel.

Leakage currents: If multiple instruments are connected to a patient, the sum of the leakage currents may exceed the limits given in IEC/EN 60601-1, IEC 60601-1-1, UL 60601-1. Consult your service personnel.

Radio frequency interference: The monitor generates, uses and radiates radio-frequency energy, and if it is not installed and used in accordance with its accompanying documentation, may cause interference to radio communications.

Use Environment

WARNING

Explosion Hazard: Do not use in the presence of flammable anesthetics or gases, such as a flammable anesthetic mixture with air, oxygen or nitrous oxide. Use of the devices in such an environment may present an explosion hazard.

Positioning Equipment: The monitor should not be used next to or stacked with other equipment. If you must stack the monitor, check that normal operation is possible in the necessary configuration before you start monitoring patients.

Environmental Specifications: The performance specifications for the monitors, measurements and accessories apply only for use within the temperature, humidity and altitude ranges specified in “Environmental Specifications” on page 458.

Liquid Ingress: If you spill liquid on the equipment, battery, or accessories, or they are accidentally immersed in liquid, contact your service personnel or Philips service engineer. Do not operate the equipment before it has been tested and approved for further use.

Prohibited Environments: The monitors are not intended for use in an MRI environment or in an oxygen-enriched environment (for example, hyperbaric chambers).

Alarms

WARNING

- Do not rely exclusively on the audible alarm system for patient monitoring. Adjustment of alarm volume to a low level or off during patient monitoring may result in patient danger. Remember that the most reliable method of patient monitoring combines close personal surveillance with correct operation of monitoring equipment.
 - Be aware that the monitors in your care area may each have different alarm settings, to suit different patients. Always check that the alarm settings are appropriate for your patient before you start monitoring.
-

Accessories

WARNING

Philips' approval: Use only Philips-approved accessories. Using other accessories may compromise device functionality and system performance and cause a potential hazard.

Reuse: Never reuse disposable transducers, sensors, accessories and so forth that are intended for single use, or single patient use only. Reuse may compromise device functionality and system performance and cause a potential hazard.

Electromagnetic compatibility: Using accessories other than those specified may result in increased electromagnetic emission or decreased electromagnetic immunity of the monitoring equipment.

Damage: Do not use a damaged sensor or one with exposed electrical contacts.

Cables and tubing: Always position cables and tubing carefully to avoid entanglement or potential strangulation.

MR Imaging: During MR imaging, remove all transducers, sensors and cables from the patient. Induced currents could cause burns.

Security Information

Protecting Personal Information

Protecting personal health information is a primary component of a security strategy. Each facility using the monitors must provide the protective means necessary to safeguard personal information consistent with country laws and regulations, and consistent with the facility's policies for managing this information. Protection can only be realized if you implement a comprehensive, multi-layered strategy (including policies, processes, and technologies) to protect information and systems from external and internal threats.

As per its intended use, the patient monitor operates in the patient vicinity and contains personal and sensitive patient data. It also includes controls to allow you to adapt the monitor to the patient's care model. To ensure the patient's safety and protect their personal health information you need a security concept that includes:

- **Physical security access measures** - access to the monitor **must** be limited to authorized users. It is essential that you consider physical security measures to ensure that unauthorized users cannot gain access.
- **Operational security measures** - for example, ensuring that patients are discharged after monitoring in order to remove their data from the monitor.
- **Procedural security measures** - for example, assigning only staff with a specific role the right to use the monitors.

In addition, any security concept must consider the requirements of local country laws and regulations.

Always consider data security aspects of the network topology and configuration when connecting patient monitors to shared networks. Your medical facility is responsible for the security of the network, where sensitive patient data from the monitor may be transferred.

Note: Log files generated by the monitors and measurement modules are used for system troubleshooting and do not contain patient data.

About HIPAA Rules

If applicable, your facility's security strategy should include the standards set forth in the Health Insurance Portability and Accountability Act of 1996 (HIPAA), introduced by the United States Department of Health and Human Services. You should consider both the security and the privacy rules and the HITECH Act when designing policies and procedures. For more information, please visit <http://www.hhs.gov/ocr/privacy/>.

About the EU Directives

If applicable, your facility's security strategy should include the practices set forth in the Directive on the protection of individuals with regard to the processing of personal data and on the free movement of such data (Directive 95/46/EC of the European Parliament and of the Council of 24 October 1995). In addition, your facility should also take into account any additional, more stringent standards put forward by any individual EU countries; that is, Germany, France, and so on. For more information, please visit http://eur-lex.europa.eu/en/dossier/dossier_27.htm.

Philips Product Security Policy Statement

Additional security and privacy information can be found on the Philips product security web site at <http://www.healthcare.philips.com/main/support/equipment-performance/product-security/index.wpd>

Manufacturer Disclosure Statement for Medical Device Security – MDS2

You can view the Manufacturer Disclosure Statements for Medical Device Security (MDS²) for specific devices at <http://www.healthcare.philips.com/main/support/equipment-performance/product-security/index.wpd>

Introducing the Monitor

The IntelliVue MX400/MX450, MX500/MX550, and MX600/MX700/MX800 patient monitor offers a monitoring solution optimized for the high-end surgical, cardiac, medical and neonatal care environments. Combining patient surveillance and data management, it allows multi-measurement monitoring by linking separate modules. The MX600 uses the navigation knob as primary input device

and the MX400/MX450, MX500/MX550, and MX700/MX800 use the touch screen as primary input device. All monitors have a remote control for convenient access to the five main keys and numeric data input.

The monitor stores data in trend, event, and calculation databases. You can see tabular trends (vital signs) and document them on a printer. You can view measurement trend graphs, with up to three measurements combined in each graph, to help you identify changes in the patient's physiological condition. You can view fast-changing measurement trends with beat to beat resolution and see up to four high resolution trend segments. Event surveillance enhances documentation and review of physiologically significant events by automatically detecting and storing up to 50 user-defined clinical events over a 24 hour period.

MX600/700/800 With the optional Integrated PC, you have computer functionality directly in the monitor. You can use standard applications (e.g. Web browsers), connect to the hospital network or intranet, and run a second independent display with content from the patient monitor.

An IntelliVue X2 can be connected to your monitor, where it acts as a multi-measurement module, acquiring measurements for the host monitor. When the X2 is disconnected from the original host monitor, it continues to monitor the patient as a fully independent, battery powered patient monitor, eliminating the need for a separate transport monitor. On connection to a new host monitor, the X2 resumes its role as multi-measurement module, ensuring fully continuous monitoring.

Major Parts and Keys

MX400/450/500/550

The MX400/450/500/550 monitors have the same parts, controls and indicators. Here the MX400 is shown.



- 1 Color coded alarm lamps
- 2 Alarms Off lamp
- 3 Power on/Standby switch with integrated LED: Green - On/Standby, Red - Error
- 4 AC power LED
- 5 Battery LED
- 6 Mounting quick-release lever (when this is pressed the monitor is not fixed on the mounting)
- 7 Service number and serial number
- 8 Device type

MX600/700

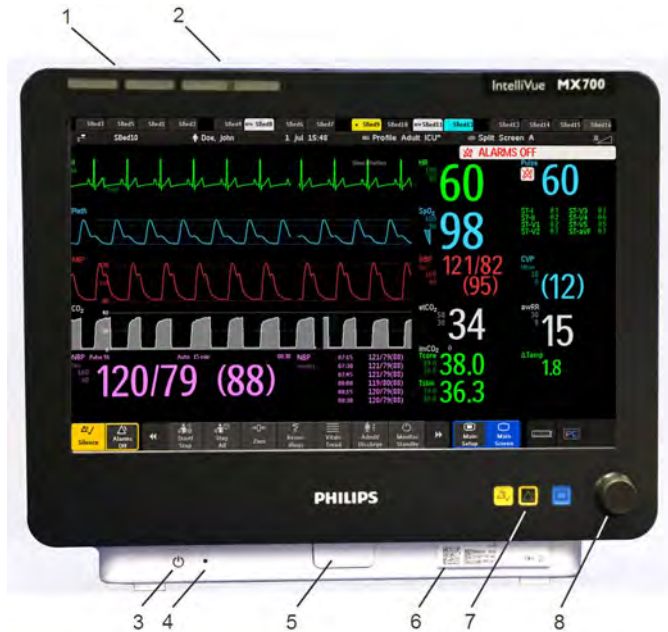

- 1 Color coded alarm lamps
- 2 Alarms Off lamp
- 3 Power on/Standby switch with integrated LED: Green - On/Standby, Red - Error
- 4 AC power LED
- 5 Mounting quick-release lever (when this is pressed the monitor is not fixed on the mounting)
- 6 Part number and serial number
- 7 Hardkeys (Silence, Alarms Off, Main Screen)
- 8 Navigation knob

MX800

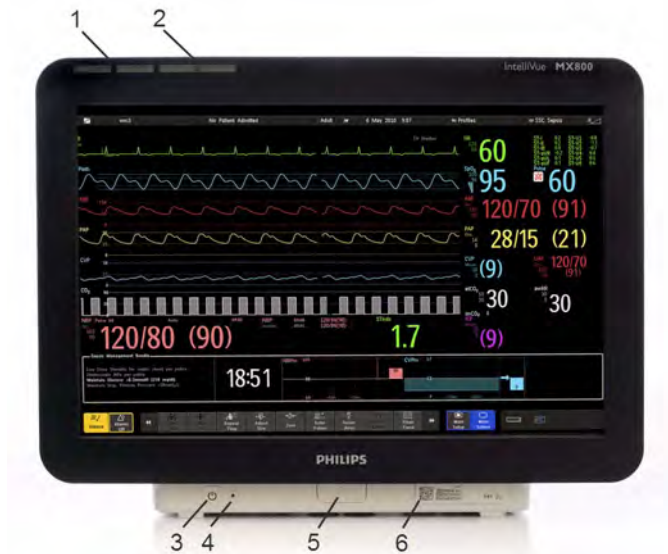

- 1 Color coded alarm lamps
- 2 Alarms Off lamp
- 3 Power on/Standby switch with integrated LED: Green - On/Standby, Red - Error
- 4 AC power LED
- 5 Mounting quick-release lever (when this is pressed the monitor is not fixed on the mounting)
- 6 Part number and serial number

Devices for Acquiring Measurements

The patient monitor acquires patient measurements using the devices described in this section. You can also extend the measurement capabilities of your monitor with such devices. Of these measurement devices, only the X2 has its own power on/standby switch, and can be powered from an external power supply or a rechargeable battery when not directly connected to the monitor (refer to the IntelliVue X2 Instructions for Use for details). All the rest take their power exclusively from the

monitor, and switch on automatically when you turn on the monitor. A green power-on LED indicates when they are drawing power from the monitor. A permanently illuminated, or flashing, red LED indicates a problem with the unit that requires the attention of qualified service personnel.

All symbols used on the front panels are explained in “Symbols” on page 445.

WARNING

When connecting devices for acquiring measurements, always position cables and tubing carefully to avoid entanglement or potential strangulation.

Flexible Module Rack (M8048A)

MX600/ The 8-slot flexible module rack (FMS-8) lets you use up to eight plug-in physiological measurement
MX700/ modules. For the MX800, you can connect two FMSs to use up to 10 measurement modules.

MX800 The maximum number of specific module types that can be used simultaneously in an FMS-8 is: five pressure modules, four temperature modules, four VueLink or IntelliBridge modules (any combination).

When two FMSs are used, in total a maximum of 10 pressure modules can be used.

Connect the FMS to the monitor via the measurement link cable (MSL). Use the MSL connector on the left-hand side to connect an additional MMS. Use the connector on the right to connect to the monitor.



- 1 X1 Multi-Measurement Module
- 2 Multi-Measurement Module mount
- 3 Flexible Module Rack FMS-8
- 4 Power on LED
- 5 Interruption indicator

4-Slot Flexible Module Rack (FMS-4)

MX600/ The 4-Slot flexible module rack (FMS-4) lets you use up to four plug-in physiological measurement
MX700/ modules.

MX800



The maximum number of specific module types that can be used simultaneously in an FMS-4 is: four pressure modules, four temperature modules, four VueLink or IntelliBridge modules (any combination).

Connect the FMS to the monitor via the measurement link cable (MSL). Use the MSL connector on the left-hand side (if you have the appropriate option) to connect an additional MMS. Use the connector on the back to connect to the monitor.

Measurement Modules

MX500/ You can use up to three plug-in modules in the optional module slots. Available modules are:

MX550

- Invasive blood pressure (M1006B)
- Temperature (M1029A)
- Oxygen saturation of arterial blood (SpO₂) (M1020B)
- Cardiac output (M1012A), and Continuous cardiac output with M1012A Option #C10
- Intravascular Oxygen Saturation - ScvO₂ or SvO₂ (M1011A)
- Spirometry (M1014A)
- EEG (M1027A)
- NMT (865383)
- IntelliBridge EC10 (865115)
- Recorder (M1116B/C)

MX600/ You can use up to eight measurement modules with the Flexible Module Rack (M8048A). Available
MX700/ modules are:

MX800

- Invasive blood pressure (M1006B)
- Temperature (M1029A)
- Oxygen saturation of arterial blood (SpO₂) (M1020B)
- Cardiac output (M1012A), and Continuous cardiac output with M1012A Option #C10
- Transcutaneous gas (M1018A)
- Mixed venous oxygen saturation - SvO₂ (M1021A)
- Intravascular Oxygen Saturation - ScvO₂ or SvO₂ (M1011A)
- EEG (M1027A)
- Bispectral Index - BIS (M1034A)
- Spirometry (M1014A)
- NMT (865383)
- VueLink device interface (M1032A)
- IntelliBridge EC10 (865115)
- Recorder (M1116B/C)

MX500/550/ You can plug in and unplug modules during monitoring. Insert the module until the lever on the
600/700/800 module clicks into place. Remove a module by pressing the lever upwards and pulling the module out. A measurement automatically switches on when you plug the module in, and switches off when you

unplug it. Reconnecting a module to the same monitor restores its label and measurement settings, such as alarms limits. If you connect it to a different monitor, the module remembers only its label.

The connector socket on the front of each module is the same color as the corresponding connector plug on the transducer or patient cable.

Press the Setup key on the module's front to display the measurement's setup menu on the monitor screen. When the setup menu is open, a light appears above the key. Some modules have a second key. On the pressure module, for example, it initiates a zeroing procedure.

Example Module (SpO₂)

MX500/550/
600/700/800



- 1 Module name
- 2 Setup key LED
- 3 Setup key to enter setup menu of measurement modules or external device data window. Some modules have a second module-specific key next to this one, for example Zero.
- 4 Connector socket for patient cable/transducer

X1 Multi-Measurement Module (M3001A)

The X1 Multi-Measurement Module (MMS) can simultaneously monitor 3-, 5-, 6- or 10-lead ECG (including arrhythmia and ST monitoring), respiration, SpO₂, NBP and either invasive pressure or temperature.

You can connect it to the monitor via a cable or mount it on the left side of the FMS.



X1 Connectors and Symbols

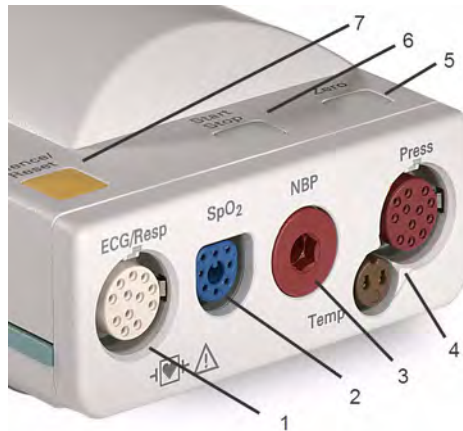

- 1 White ECG/Resp connector
- 2 Blue SpO₂ connector
- 3 Red NBP connector
- 4 Combined pressure (red) and temperature (brown) connector - connect either invasive pressure transducer or temperature probe. You might have a version of the MMS that does not have this connector.
- 5 NBP STAT key - starts NBP STAT series of measurements
or
Zero key - initiates a zero procedure for the connected pressure transducer when pressed and held for a second
- 6 NBP Start/Stop key - starts or stops NBP measurements
- 7 Silence: acknowledges all active alarms by switching off audible alarm indicators and lamps

X2 Multi-Measurement Module (M3002A)

The X2 Multi-Measurement Module (MMS) can simultaneously monitor 3-, 5-, 6- or 10-lead ECG (including arrhythmia and ST monitoring), respiration, SpO₂, NBP and either invasive pressure and temperature, or CO₂. It has a color touchscreen display.

The X2 has the added capability to operate as a stand-alone monitor, and can be powered by a rechargeable battery. This makes it particularly suited to transport situations. When the X2 is disconnected from the original host monitor, it continues to monitor the patient as a stand-alone monitor running on battery power, eliminating the need for a separate transport monitor. When the X2 is connected to a new host monitor, it resumes its role as MMS, ensuring fully continuous monitoring. For details of using the X2 as a stand-alone monitor, refer to the IntelliVue X2 Instructions for Use.

When connected to a host monitor (**Companion Mode** is indicated), the X2 takes power from the host, including that required for battery charging. The X2 can also be powered by AC mains when not connected to a host monitor using the optionally available external power supply (M8023A). See the IntelliVue X2 Instructions for Use for details.

X2 Overview

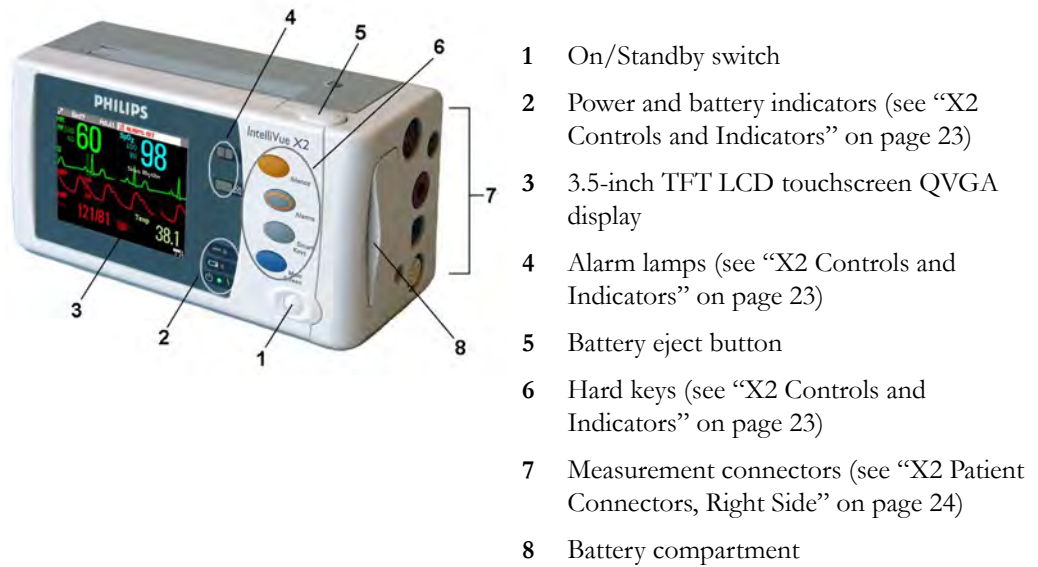

- 1 On/Standby switch
- 2 Power and battery indicators (see “X2 Controls and Indicators” on page 23)
- 3 3.5-inch TFT LCD touchscreen QVGA display
- 4 Alarm lamps (see “X2 Controls and Indicators” on page 23)
- 5 Battery eject button
- 6 Hard keys (see “X2 Controls and Indicators” on page 23)
- 7 Measurement connectors (see “X2 Patient Connectors, Right Side” on page 24)
- 8 Battery compartment

X2 Controls and Indicators

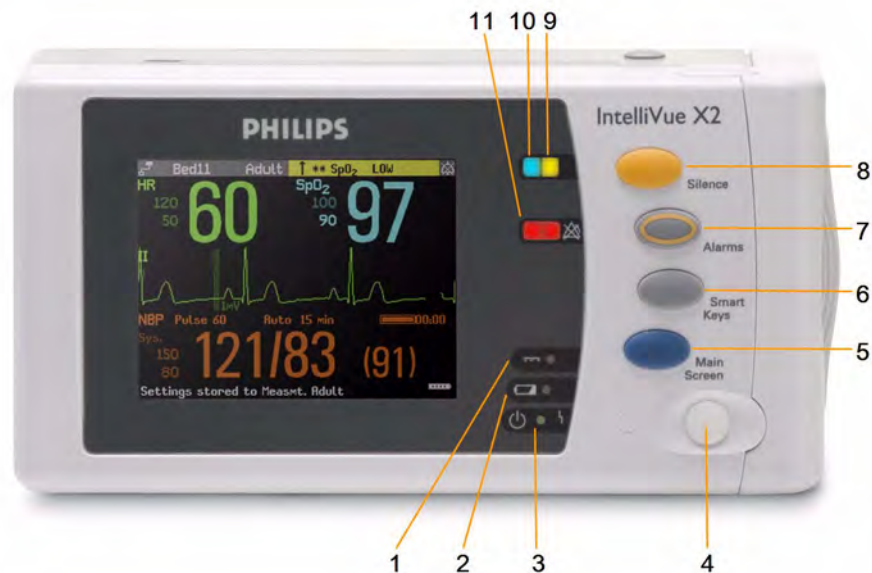

- 1 External power LED. Green when monitor is powered from an external power source.
- 2 Battery status LED. Yellow when charging. Flashing red when battery is empty.
- 3 On/Standby LED. Green when monitor is on. Red indicates an error.
- 4 On/Standby switch. Disabled when X2 is connected to a host monitor
- 5 **Main Screen** key: closes all open menus/windows and returns to the main screen.
- 6 **SmartKeys** key: brings up SmartKeys on the screen.
- 7 **Alarms** key: turns alarms On/Off, or pauses them.

1 Introduction

- 8 **Silence** key
- 9 Active alarm lamp. Red or yellow, depending on alarm level. Blinks until active alarm is acknowledged.
- 10 Active INOP alarm lamp in light blue. Blinks until active INOP is acknowledged.
- 11 Alarms off indicator. When alarms are suspended, the lamp is red (or yellow when yellow alarms are suspended), and the alarms off symbol is shown.

X2 Patient Connectors, Right Side

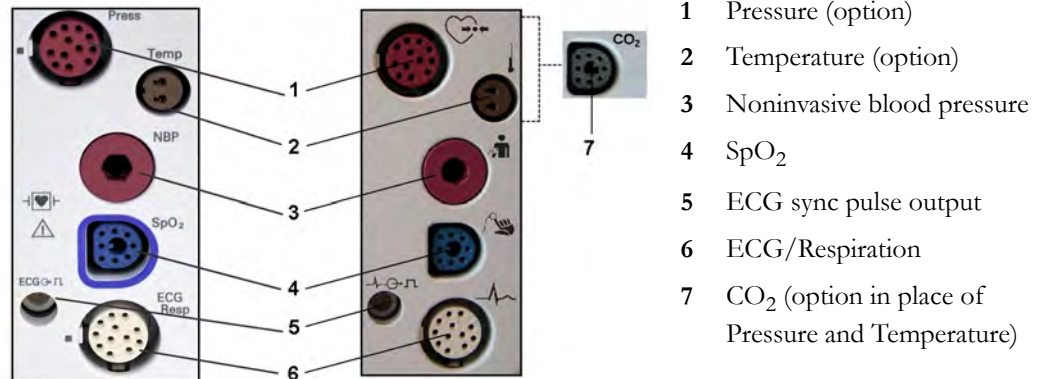

X2 Left Side



MMS Extensions

The MMS extensions connect to the X1 and X2 MMS and use the MMS settings and power. Trend data and measurement settings from the measurements in the extensions are stored in the MMS.

WARNING

- The MMS extensions can only function when they are connected to an MMS. If the MMS is removed during monitoring, the measurements from both the MMS **and** the extension are lost.
- Measurements from an MMS extension connected to an X2 are not available when the X2 is running on its own battery power. They are only available when the X2 is powered from AC mains, when connected to a host monitor or the external power supply (M8023A), or from the Battery Extension.

To separate an extension from the MMS, press the release lever down, and push the MMS forward.



M3014A, M3015A, M3015B and M3016A Capnography MMS Extensions

The optional **M3014A** Capnography extension adds mainstream capnography or sidestream capnography, and optionally one pressure plus either a pressure or a temperature, Cardiac Output and Continuous Cardiac Output to the MMS.

M3014A



- 1 Pressure connectors (red)
- 2 Temperature connector (brown)
- 3 Mainstream/sidestream connector CO₂
- 4 Cardiac Output connector

1 Introduction

The optional **M3015A** Microstream CO₂ extension adds microstream capnography and optionally either pressure or temperature to the MMS. The optional **M3015B** Microstream CO₂ extension adds microstream capnography, two pressures and a temperature to the MMS.

M3015A

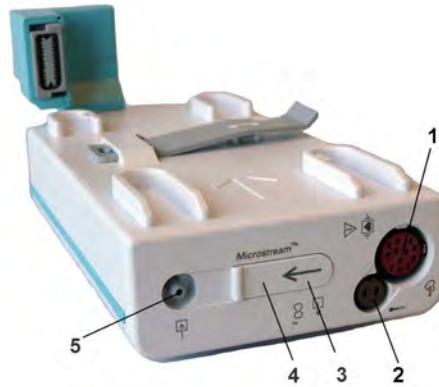

M3015B



- 1 Pressure connectors (red) - M3015A optional
- 2 Temperature connector (brown) - M3015A optional
- 3 Inlet
- 4 Microstream connector CO₂
- 5 Gas sample outlet

MX600/700/800 The optional **M3016A** Mainstream CO₂ extension adds mainstream capnography and optionally either pressure or temperature to the MMS.

M3016A



- 1 Pressure connector (red)
- 2 Temperature connector (brown)
- 3 Mainstream/sidestream connector CO₂ (optional)

When a capnography extension is connected to an X2 MMS with CO₂, the CO₂ from the extension will be automatically deactivated in favor of the one in the X2. If you prefer to use the CO₂ measurement on the extension, you can activate it via the measurement selection key (see “Resolving Label Conflicts” on page 44).

The cardiac output measurement in the M3014A is deactivated when the extension is used with an X2 MMS, even if the X2 is connected to an external power supply. The cardiac output measurement is only available when the X2 is connected to a host monitor.

M3012A Hemodynamic MMS Extension



- 1 Cardiac Output (orange; optional)
- 2 Connection to MMS
- 3 Pressure connectors (red)
- 4 Temperature connectors (brown)

The M3012A Hemodynamic extension can be connected to the M3001A Multi-Measurement Module to provide the following additional measurements: Temperature, Pressure, an additional Pressure or Temperature, and C.O. and CCO measurements.

The cardiac output measurement is deactivated when the extension is used with an X2 MMS unless the X2 is connected to a host monitor.

Using MMSs in a Mixed Software Environment

When an MMS is used with monitors having different software revisions, be aware that functionality set up in a monitor with a newer revision will disappear when the MMS is connected to a monitor with an older revision without that functionality. For example, if an X2 is used with a revision H monitor and has been set up to alarm on Afib, this alarm will no longer exist when the X2 is connected to a revision G monitor. If you work in a mixed software environment, inform yourself about the differences between revisions by referring to the What's New chapter.

Operating and Navigating

Everything you need to operate the monitor is contained on its screen. Almost every element on the screen is interactive. Screen elements include measurement numerics, waveforms, screen keys, information fields, alarms fields and menus. The typical operator's position is in front of the monitor.

The configurability of the monitor means that often you can access the same element in different ways. For example, you might be able to access an item through its on-screen setup menu, via a hard key, or via a SmartKey.

1 Introduction

MX400

On the MX400, the permanent keys and the key to access the SmartKeys are on the right of the screen.

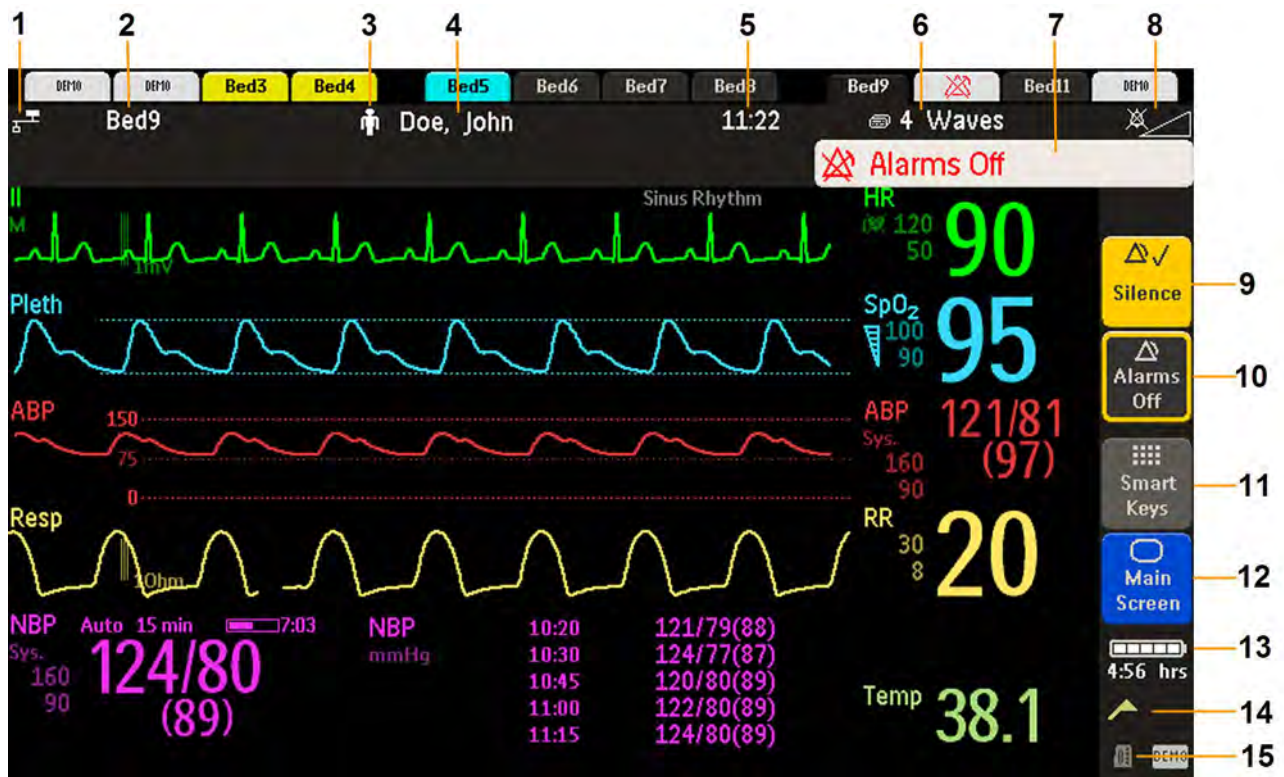

Monitor information line		Other screen elements	
1	network connection indicator (documented in <i>Troubleshooting</i> in the Service Guide)	9	Silence - acknowledges all active alarms by switching off audible alarm indicators and lamps permanently or temporarily, if alarm reminder (ReAlarm) is configured on.
2	bed label - gives access to Equipment window	10	Pause Alarms or Alarms Off - stops alarms being announced for a set time or switches them off. Select again to immediately switch alarms on again. Can be configured not to appear here.
3	patient category symbol	11	SmartKeys -displays a block of SmartKeys. These change according to your monitor's configuration
4	patient name	12	close all open menus and windows and return to main screen
5	date and time	13	battery indicator with remaining battery time
6	current screen name/enter Change Screen menu	14	status messages indicator - clicking this area displays any pending status messages
7	alarm status area - shows active alarm messages or Alarms Off symbol when alarms are switched off	15	measurement selection symbol - opens Measurement Selection window to resolve label conflicts
8	alarms off/alarm volume indicator		

MX450/500/550/600/700/800

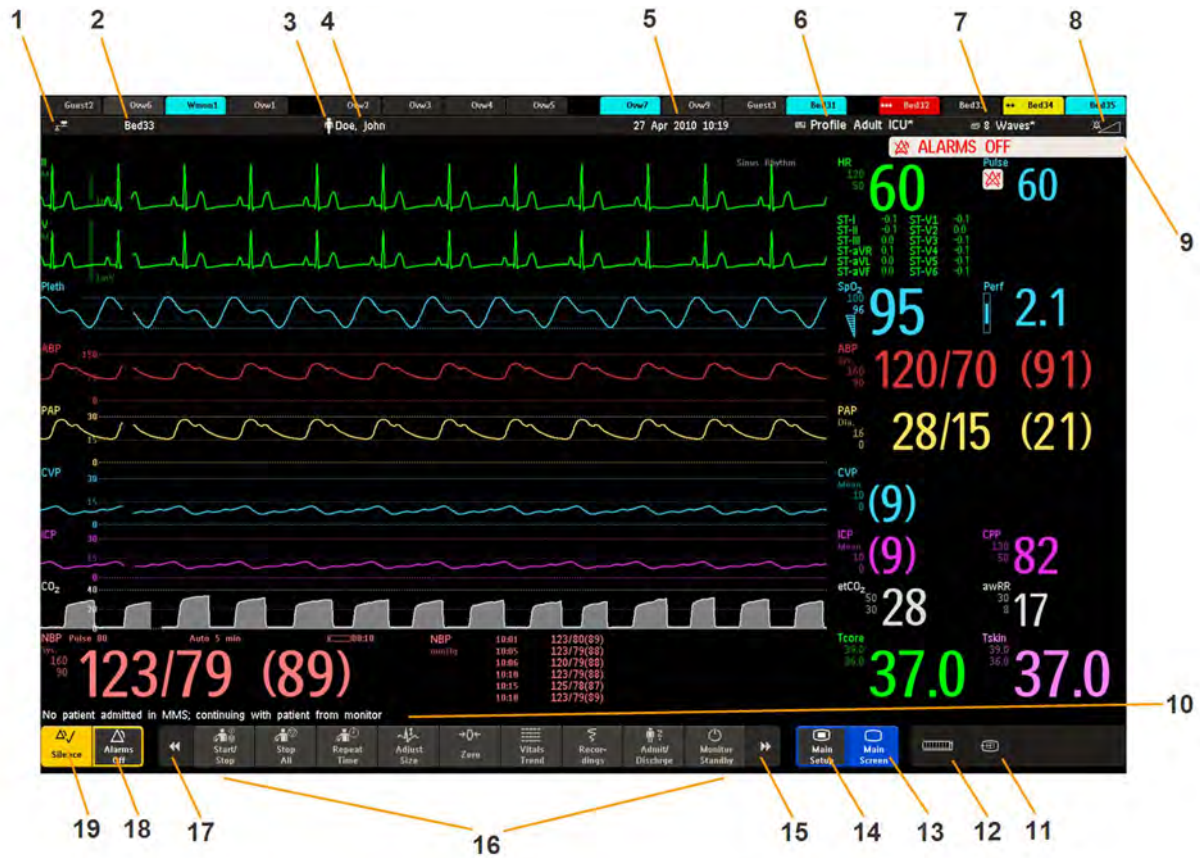

Monitor information line		Other screen elements	
1	network connection indicator (documented in <i>Troubleshooting</i> in the Service Guide)	10	The status line shows messages with information and prompts you for possible actions (MX400/450/500/550 do not have a reserved space for this feature).
2	bed label - gives access to Equipment window	11	remote application symbol or iPC symbol (MX600/700/800 only)
3	patient category symbol	12	measurement selection symbol - opens Measurement Selection window to resolve label conflicts
4	patient name	13	close all open menus and windows and return to main screen
5	date and time	14	enter Main Setup menu
6	access the Profiles menu or Profile name, depending on configuration	15	scroll right to display more SmartKeys
7	current screen name/enter Change Screen menu	16	SmartKeys - these change according to your monitor's configuration
8	adjust alarm volume/level indicator	17	scroll left to display more SmartKeys
9	alarm status area - shows active alarm messages or Alarms Off symbol when alarms are switched off	18	Pause Alarms or Alarms Off - stops alarms being announced for a set time or switches them off. Select again to immediately switch alarms on again. Can be configured not to appear here.
		19	Silence - acknowledges all active alarms by switching off audible alarm indicators and lamps permanently or temporarily, if alarm reminder (ReAlarm) is configured on.

Selecting Screen Elements

Select a screen element to tell the monitor to carry out the actions linked to the element. For example, select the Patient Identification element to call up the **Patient Demographics** window, or select the HR numeric to call up the **Setup ECG** menu. Select the ECG wave segment to call up the **ECG Lead** menu.

Note that the space between each line of a menu may be configured to wide or narrow to facilitate your most common method of operation, either touch, remote control or a pointing device such as a mouse.

Using the Touchscreen

Select screen elements by pressing them directly on the monitor's screen.

Disabling Touchscreen Operation

To temporarily disable touchscreen operation of the monitor, press and hold the **Main Screen** permanent key. A padlock will appear on the **Main Screen** permanent key.



Press and hold the **Main Screen** permanent key again to re-enable the touchscreen operation.

Using a Mouse or Trackball

If you are using a mouse or trackball, select screen elements by clicking on them (press and release the left mouse button). While you are moving the mouse, a cursor appears and a highlight shows your current position.

Moving Windows

You can move windows and menus using the Touchscreen or a mouse. To move a window,

- 1 Select the title of the window and keep your finger on the title, or the mouse button pressed.
- 2 Move your finger on the Touchscreen, or move the mouse, to move the window.
- 3 Take your finger off the screen, or release the mouse button, to place the window in the final position.





The new position is only active until the window or menu is closed. Not all locations on the screen can be a target position, a window cannot overlap the monitor info line, the alarms and INOPs or the status line.

Using Keys

The monitor has four different types of keys:

Permanent Keys



















A permanent key is a graphical key that remains on the screen all the time to give you fast access to functions.

	Pause Alarms - pauses alarm indicators. Pause duration depends on monitor configuration. If pause duration is infinite, this key is labeled Alarms Off . Select again to immediately re-enable alarm indicators.
	Silence - acknowledges all active alarms by switching off audible alarm indicators and lamps.
	Main Screen - close all open menus and windows and return to the main screen.
	Main Setup - enter main setup menu.

















SmartKeys

A SmartKey is a configurable graphical key, normally located at the bottom of the main screen. On some models, a selection of SmartKeys is displayed by selecting the SmartKeys permanent key on the right of the main screen.

SmartKeys give you fast access to functions. The selection of SmartKeys available on your monitor depends on your monitor configuration and on the options purchased. If you have an integrated PC (iPC) you may also see SmartKeys generated by applications on the iPC.

	enter profile menu, or revert to default profile		change Screen, or revert to default screen
	show BIS Sensor		previous Screen
	freeze waves		quick admit a patient
	set alarm limits		enter patient demographics menu to admit/discharge/transfer
	change alarm volume		end case to discharge a patient
	change QRS volume		view information for patients in other beds
	enter standby mode - suspends patient monitoring. All waves and numerics disappear from the display. All settings and patient data information are retained.		change screen brightness (not for independent displays)
	review beat labels (annotate arrhythmia wave)		re-learn arrhythmia
	change amplitude (size) of ECG wave		enter cardiac output procedure

	- start/stop manual NBP measurement - start auto series - stop current automatic measurement within series		start NBP STAT measurement
	start NBP measurement and measurement series		stop automatic or STAT NBP measurement and measurement series
	start venipuncture (inflate cuff to subdiastolic pressure)		stop current NBP measurement
	access NBP mode selection and setup, with direct start/stop function		set the NBP repeat time
	start a delayed recording		zero invasive pressure transducer
	access Vital Signs recording function		access pop-up recording keys
	set wide automatic alarm limits		access Select Waves recording function
	access wedge procedure window		set narrow automatic alarm limits
	review vital signs trend		access the Loops window
	access event surveillance		review graph trend
	access the calculator		access calculations
	gas analyzer - exit standby mode		access the Drug Calculator
	unpair equipment and continue central monitoring with the monitor		suppress zero for all gas measurements
	unpair equipment and continue central monitoring with the telemetry device		access ST Map application
	access the spirometry data window		access remote applications (if Application Server is connected)
	start 12-Lead Capture (only available if Information Center is connected)		

	access EEG CSA		access the EEG montage
	display external device information		access timers
	access ProtocolWatch		set standard or EASI lead placement
	switch CO ₂ pump off		new lead setup
	enter data manually		start/stop car seat assessment record
	open the Histogram window		open Unit Conversion window
	start an NMT measurement cycle		stop an NMT measurement cycle
	start NMT calibration		access patient reports
	open the Equipment window		

Hardkeys

A hardkey is a physical key on a monitoring device, such as the zero pressure key on the MMS or a setup key on a module.

Pop-Up Keys

Pop-up keys are task-related graphical keys that appear automatically on the monitor screen when required. For example, the **Confirm** pop-up key appears only when you need to confirm a change.

Using the Remote Control



The remote control provides you with direct access to five hard keys, a navigation knob and a numeric keypad:

Hardkeys	
1	Silence - acknowledges all active alarms by switching off audible alarm indicators and lamps. Behavior follows the Silence permanent key configuration.
2	Alarms Off/Pause Alarms - pauses alarm indicators. Behavior follows the Pause Alarms permanent key configuration.
3	Main Screen - close all open menus and windows and return to the main screen.
4	SmartKeys - display a block of SmartKeys specially configured for remote tasks (see below)
5	Back - go back one step to the previous menu.
6	Enter - mark the end of data entry
Keypad	
7	Type numeric data on the keypad and press the Enter key to enter the data on the monitor.
Navigation knob	
8	Rotate the knob to highlight screen elements, then press to select the highlighted element.

The remote control can be used with a USB cable connection to the monitor or without a cable using short range radio. When used without a cable, the remote control must be assigned to the monitor. The assignment is made in Configuration or Service mode.

CAUTION

When using a remote control without a cable, it is important that the user knows which remote control is assigned to which monitor. Use the tethering cable delivered with the remote control to attach it to a bed rail or IV pole, or label the remote control with the bed or monitor ID.

Using the SmartKeys Key

The SmartKeys hard key on the remote control displays a block of SmartKeys on the monitor screen. Nine SmartKeys appear in a 3 by 3 matrix which corresponds to the layout of the numeric pad on the remote control.



Pressing the 1 key on the remote control selects the top left SmartKey, pressing the 8 key selects the bottom center SmartKey. The . and the ↵ key can be used to select the arrow keys to page up and down in the available SmartKeys.

The SmartKeys which appear can be configured so that you have the functions available which you most often need when using the remote control. If no list of SmartKeys has been configured, the standard SmartKeys will be displayed and you can page through to the key you want.

Using the On-Screen Keyboard

Use this as you would a conventional keyboard. Enter the information by selecting one character after another. Use the **Shift** and capital **Lock** keys to access uppercase letters. Use the **Back** key to delete single characters, or use the **Clr** key to delete entire entries. Select **Enter** to confirm what you have entered and close the on-screen keyboard.

If a conventional keyboard is connected to the monitor, you can use this instead of or in combination with the on-screen keyboard.

Using the On-Screen Calculator

You can use the on-screen calculator to perform any of the standard operations for which you would normally use a handheld calculator.

- To access the on-screen calculator, select the **Calculator** SmartKey, or select **Main Setup** then **Calculations** followed by **Calculator**.

Operating Modes

When you switch the monitor on, it starts up in monitoring mode. To change to a different mode:

- 1 Select the **Main Setup** menu.
- 2 Select **Operating Modes** and choose the mode you require.

Your monitor has four operating modes. Some are passcode protected.

- **Monitoring Mode:** This is the normal, every day working mode that you use for monitoring patients. You can change elements such as alarm limits, patient category and so forth. When you discharge the patient, these elements return to their default values. Changes can be stored permanently only in Configuration Mode. You may see items, such as some menu options or the altitude setting, that are visible but ‘grayed out’ so that you can neither select nor change them. These are for your information and can be changed only in Configuration Mode.
- **Demonstration Mode:** Passcode protected, this is for demonstration purposes only. You must not change into Demonstration Mode during monitoring. In Demonstration Mode, all stored trend information is deleted from the monitor’s memory.
- **Configuration Mode:** Passcode protected, this mode is for personnel trained in configuration tasks. These tasks are described in the Configuration Guide. During installation the monitor is configured for use in your environment. This configuration defines the default settings you work with when you switch on, the number of waves you see and so forth.
- **Service Mode:** Passcode protected, this is for trained service personnel.

When the monitor is in Demonstration Mode, Configuration Mode, or Service Mode, this is indicated by a box with the mode name in the center of the Screen and a symbol in the bottom right-hand corner. Select the mode box in the center of the screen to change to a different mode.

When an X2 is connected to a host monitor (**Companion Mode** is indicated):

- The monitor in companion mode will adopt the operating mode of the host monitor.
- You cannot change the operating mode at the monitor in companion mode.

Standby Mode

Standby mode can be used when you want to temporarily interrupt monitoring.

To enter Standby mode,

- select the **Monitor Standby** SmartKey or
- select **Main Setup**, followed by **Monitor Standby**.

The monitor enters Standby mode automatically after the End Case function is used to discharge a patient.

Standby suspends patient monitoring. All waves and numerics disappear from the display but all settings and patient data information are retained. A special Standby screen is displayed. This can be configured to a moving image or a blank screen, or to your own custom image. If a temporary patient location has been entered at the monitor or at the Information Center, this location will also be displayed on the Standby screen.

To resume monitoring,

- Select anything on the screen or press any key.

When monitoring is resumed, alarms are paused for 1 minute to allow time to finish plugging in the measurement cables.

If you connect an X2 that is powered on (and not in Standby) to a host monitor in Standby mode, the host will leave Standby mode. When connected to a host monitor, with both the host and the monitor in companion mode in Standby mode, leaving Standby on the monitor in companion mode will also make the host leave Standby.

Understanding Screens

Your monitor comes with a set of pre-configured Screens, optimized for common monitoring scenarios such as "OR adult", or "ICU neonatal". A Screen defines the overall selection, size and position of waves, numerics and other elements on the monitor screen when you switch on. You can easily switch between different Screens during monitoring. Screens do NOT affect alarm settings, patient category and so forth.

When you switch from a complex to a less complex Screen layout, some measurements may not be visible but are still monitored in the background. If you switch to a more complex Screen with, for example, four invasive pressure waves but you have only two pressures connected to the monitor, the "missing" two pressures are either left blank or the available space is filled by another measurement.

Switching to a Different Screen

- 1 To switch to a different Screen, select the current Screen name in the monitor info line, or select the **Change Screen** SmartKey.



- 2 Choose the new Screen from the pop-up list.

Changing a Screen's Content

If you do not want to change the entire Screen content, but only some parts of it, you can substitute individual waves, numerics, high-res waves, or trends. Be aware that these changes cannot be stored permanently in Monitoring Mode.

To change the selection of elements on a Screen,

- 1 Select the element you want to change.
- 2 From the menu that appears, select **Change Wave**, **Change Numeric**, or **ChangeHiResTrend**, and then select the wave or numeric you want, or select the high-resolution trend wave you want from the list of available waves.

If you do not see **Change Numeric** in the menu, this Screen may be configured to always display the numeric beside its wave. Changing the wave will automatically change the numeric.

The changed Screen is shown with an asterisk in the monitor info line.

In the **Change Screen** menu, the changed Screen is shown linked to the original Screen and marked with an asterisk.

Up to three modified Screens can be accessed via the **Change Screen** menu.

To recall Screens, either

- select the name of the Screen in the **Change Screen** menu

or

- use the previous arrow at the top of the **Change Screen** menu to move back in the Screen history. The ten most recently-used Screens including up to three modified Screens can be accessed.

After a patient discharge, the monitor's default Screen is shown. Modified Screens are still available in the **Change Screen** menu.

If the monitor is switched off and then on again, modified Screens are erased from the monitor's memory and cannot be recalled. If a modified Screen was the last active Screen when the monitor was switched off, it is retained (unless **Automat. Default** is configured to **Yes**).

Connecting Additional Displays to the Monitor

You can connect a second display, showing the same Screen as the main display, to your monitor, for **viewing** only.

Independent Displays

MX600/700/800 If you have the optional independent display interface, you can connect a second display which can be configured and operated individually using standard input devices.

For monitors with multiple displays and multiple input devices, the usage and behavior can be configured according to specific requirements at installation (for example, use for two independent operators or tracking of mouse input across two displays). For details refer to the Service Guide.

When two operators are using two displays, the scope of an action depends on the type of operation:

- Patient monitoring operations such as Silence or Pause alarms take effect for the monitor as a whole, the results will be seen on both displays.
- Display operations such as the **Main Screen** key and Back hardkey will take effect only on the display being operated.

If you are operating two displays with one remote control, to navigate from one display to another:

- 1 Move the highlight to the **Main Screen** key and then turn one click further. The highlighting moves to a special "jump" field at the edge of the Screen.
- 2 Press the navigation knob on the remote control to confirm; the highlighting will automatically move to the other display.

The content of each Screen can be changed individually as described in the previous section. If you are operating two displays, you can choose Screens for both displays from one location:

- 1 Select **Profiles** in the monitor info line of the first display,
- 2 Select **Display 1**, or **Display 2**, then select the Screen you want to appear on that display from the list of available Screens.

When two displays are mounted next to each other or one above the other, a special Screen can be assigned which spans across both displays. The Screen content for these Tall and Wide Screens can then use the increased area available with two displays. These Screens appear in the Screen list with a special Tall Screen or Wide Screen symbol.

Certain windows (for example: cardiac output procedure) can only be shown on one display at a time. If you try to open one of these windows when it is already shown on another display, you will see a blank gray window with a cross through it.

Using the XDS Remote Display

MX600/700/800 Using the IntelliVue XDS solution it is possible to view an independent monitor screen on an external display. The XDS solution consists of a medical grade PC-based hardware platform, XDS application software and the XDS connectivity option on the monitor. Depending on the configuration you can also operate the monitor from the external display. The XDS must be connected to the same Local Area Network (LAN) as the monitor.

It is also possible to use an existing PC, connected to the same LAN, to host the XDS Application software.

For more details, including limitations and restrictions, refer to the IntelliVue XDS Application Instructions for Use.

Using the Visitor Screen

If a visitor Screen is configured for your monitor, you can use it to clear the screen of all waves and numerics but continue to monitor the patient with active alarms and trend storage at the bedside and Information Center. You can change the name of the visitor Screen in Configuration Mode.

- To activate this Screen, select the Screen name in the monitor info line to open the **Change Screen** menu, then select the name of the visitor Screen configured for your monitor from the list of available Screens.

To select a Screen with waves and numerics again,

- Select the visitor Screen's name below the clock to open the **Change Screen** menu and select a different Screen to show waves and numerics again.

Understanding Profiles

Profiles are predefined monitor configurations. They let you change the configuration of the whole monitor so you can adapt it to different monitoring situations. The changes that occur when you change a complete profile are more far reaching than those made when you change a Screen. Screens affect only what is shown on the display. Profiles affect all monitor and measurement settings.

The settings that are defined by Profiles are grouped into three categories. Each category offers a choice of 'settings blocks' customized for specific monitoring situations. These categories are:

- **Display (screens)**
Each profile can have a choice of many different predefined screens.
If you are using a second display, each display can have its own individual screen selection. When you change the profile, the screen selection configured for the new profile becomes active.
- **Measurement Settings**
Each profile can have a choice of different predefined measurement settings. These relate directly to individual measurements, for example, measurement on/off, measurement color, alarms limits, NBP alarm source, NBP repeat time, temperature unit (°F or °C), pressure unit (mmHg or kPa).
- **Monitor Settings**
Each profile can have a choice of different predefined monitor settings. These relate to the monitor as a whole; for example, display brightness, alarms off/paused, alarm volume, QRS tone volume, tone modulation, prompt tone volume, wave speed, resp wave speed, pulse source.

You can change from one complete profile to another or swap individual settings blocks (display/monitor settings/measurement settings) to change a subset of a profile. Changes you make to any element within the settings blocks are not saved when you discharge the patient, unless you save them in Configuration Mode.

Depending on your monitor configuration, when you switch on or discharge a patient the monitor either continues with the previous profile, or resets to the default profile configured for that monitor.

WARNING

- If you switch to a different profile, the patient category and paced status normally change to the setting specified in the new profile. However some profiles may be set up to leave the patient category and paced status unchanged. Always check the patient category, paced status, and all alarms and settings, when you change profiles.
 - If your monitor is configured to show the profile name in the info line at the top of the screen, be aware that individual settings may have been changed by other users or by settings synchronization since the profile was loaded. Hence settings may be different than implied by the profile name.
-

When you leave Demonstration Mode, the monitor uses the default profile.

Swapping a Complete Profile

- 1 Select **Profiles** in the monitor info line, or select the **Profiles** SmartKey.



- 2 Select the **Profile Details** pop-up key.
- 3 In the **Profiles** menu, select **Profile**.
- 4 Choose a profile from the pop-up list.
- 5 Confirm your selection.

Swapping a Settings Block

- 1 Select the Profile in the monitor info line.
- 2 Select the **Profile Details** pop-up key.
- 3 In the **Profile Details** menu, select **Display** or **Measmnt.Settings** or **Monitor Settings** to call up a list of the settings blocks in each category.
- 4 Choose a settings block from the pop-up list.
- 5 Confirm your selection.

Default Profile

Your monitor has a default profile that it uses when you leave Demonstration mode, or when you discharge a patient. This profile is indicated by a diamond shaped symbol.

Locked Profiles



Some profiles are locked, so that you cannot change them, even in Configuration Mode. These are indicated by this lock symbol.

Understanding Settings

Each aspect of how the monitor works and looks is defined by a setting. There are a number of different categories of settings, including,

Screen Settings, to define the selection and appearance of elements on each individual Screen

Measurement settings, to define settings unique to each measurement, for example, high and low alarm limits

Monitor settings, including settings that affect more than one measurement or Screen and define general aspects of how the monitor works, for example, alarm volume, reports and recordings, and display brightness.

You must be aware that, although many settings can be changed in Monitoring Mode, permanent changes to settings can only be done in the monitor's Configuration Mode. All settings are reset to the stored defaults:

- when you discharge a patient
- when you load a Profile
- when the monitor is switched off for more than one minute (if **Automat. Default** is set to **Yes**).

Changing Measurement Settings

Each measurement has a setup menu in which you can adjust all of its settings. You can enter a setup menu:

- via the measurement numeric - select the measurement numeric to enter its setup menu. For example, to enter the **Setup ECG** menu, select the HR (heart rate) numeric.
- via the Setup hardkey (on plug-in modules) - press the Setup hardkey on the module front.
- via the **Main Setup** permanent key - if you want to setup a measurement when the measurement is switched off, use the **Main Setup** permanent key and select **Measurements**. Then select the measurement name from the pop-up list. With this permanent key you can access any setup menu in the monitor.
- via the Measurement Selection key.

This guide always describes the entry method using the setup menu. But you can use any method you prefer.

Switching a Measurement On and Off

When a measurement is off, its waves and numerics are removed from the monitor's screen. The monitor stops data acquisition and alarming for this measurement. A measurement automatically switches off if you disconnect its module or MMS. If you disconnect a transducer, the monitor replaces the measurement numeric with question marks. If you silence the resulting INOP, the measurement is switched off. Also if you pause or switch off alarms, the measurement may be switched off completely, depending on your configuration.

- 1 Enter the measurement's setup menu and select the measurement.
- 2 Select the measurement name to switch between on and off. The screen display indicates the active setting.

Switching Numerics On and Off

For some measurements, such as EEG, you can choose which numerics to view on the screen.

In the measurement's setup menu, select the numeric name to toggle between on and off.

For example in the **Setup EEG** menu, select the EEG numeric name to toggle between on and off.

Adjusting a Measurement Wave

To quickly adjust wave-related measurement settings (such as speed or size), select the measurement wave itself. This displays the measurement wave menu, which has only wave-related measurement settings.

Changing Wave Speeds

Lowering the wave speed compresses the wave and lets you view a longer time period. Increasing the speed expands the waveform, giving you a more detailed view.

The monitor distinguishes three groups of wave speed settings:

- **RespiratorySpeed**, for all respiratory waves: CO₂, anesthetic agents and O₂
- **EEG Speed**, for all EEG and BIS waves
- **Global Speed**, for all waves not included in the other two groups.

Changing the Wave Group Speed

The wave speed group setting defines the speed of all the waves in the group.

To change the wave speed of a wave speed group,

- 1 Select **Main Setup**, then select **User Interface**
- 2 Select **Global Speed**, **RespiratorySpeed**, or **EEG Speed** as required
- 3 Select a value from the list of available speeds.

Changing Wave Speed for a Channel

To change the wave speed of an individual wave channel,

- 1 Enter the Wave menu for a measurement by selecting its wave.
- 2 Select **Change Speed**.
- 3 To set the speed to the wave group speed, select **RespiratorySpeed**, **EEG Speed**, or **Global Speed**.

To set an individual channel speed, select a numeric value from the list of available speeds. This overrides the wave group speed setting and set the speed for the individual wave channel on the monitor Screen. The wave channel speed is independent of the wave (label) depicted in the channel, if you change the wave, the new wave will retain the set channel speed.

Freezing Waves

You can freeze waves on the screen and measure parts of the wave using cursors. The waves are frozen with a history of 20 seconds so that you can go back and measure what you have seen.

Freezing An Individual Wave

To freeze a wave,

- 1 Enter the Wave menu for the measurement by selecting the wave on the screen.
- 2 Select **Freeze Wave**.

The realtime wave is replaced with the frozen wave.

Freezing All Waves

To freeze all waves on the screen,

- 1 Select the **Freeze Waves** SmartKey.



All realtime waves are replaced with frozen waves.

Measuring Frozen Waves

To measure a frozen wave,

- 1 Select the frozen wave.

If you are using touch, this automatically positions the vertical cursor. The cursor can be repositioned by touching the required point on the wave, **or**

- 2 Using the SpeedPoint or another pointing device or touch: use the right/left arrow keys to move the vertical cursor.

The vertical cursor moves through the time axis and the current value is displayed next to the cursor.

- 3 Use the up/down arrow keys to activate and move the horizontal cursor.

The horizontal cursor measures the wave value, which is displayed above the cursor line. If the wave is a pressure wave, the cursor value can be stored as a systolic, diastolic or mean pressure value; if the pressure wave is a PAP wave it can also be stored as a PAWP value; for pressure waves P, P1 to P8 it can also be stored as an IAP value. The stored value appears in the trend database as a manually entered value.

Changing The Wave Speed

Lowering the wave speed compresses the wave and lets you view a longer time period. Increasing the speed expands the waveform, giving you a more detailed view.

To change the wave speed:

- 1 Select the frozen wave.
- 2 Select **Change Speed**.
- 3 Select a speed from the list.

Updating The Frozen Wave

To update the wave, that is freeze the current wave:

- 1 Select the frozen wave.
- 2 Select **Freeze Again**.

Releasing Frozen Waves

To release frozen waves,

- 1 Select a frozen wave.
- 2 Select **Unfreeze Waves**.

All frozen waves are released.

Using Labels

Every measurement associated with a monitor is identified by a unique label. You may have more than one instance of some measurements, for example pressure, being used simultaneously. The monitor uses the labels to distinguish between them. The default settings defined in the profile (such as measurement color, wave scale, and alarm settings) are stored within each label. When you assign a label to a measurement, the monitor automatically applies these default settings to the measurement. The labels assigned are used throughout the monitor, in reports, recordings, and in trends.

Changing Measurement Labels (e.g. Pressure)

To change a measurement label of a measurement with multiple labels (e.g. invasive pressure or temperature),

- 1 Enter the wave menu of the measurement.
- 2 Select **Label**.
- 3 Choose a label from the list.

The monitor automatically applies the scale, color, etc. settings stored in the Profile for the label you select. You can change scale settings in Monitoring Mode, but color can only be changed in the monitor's Configuration Mode.

Any labels already being used in the monitor are shown "grayed-out" in the list and cannot be selected.

About Label Sets

Your monitor may be configured to use a **Restricted** or **Full** label set. The **Full** label set provides extra labels for Pressure and Temp. See the sections on Pressure and Temperature in these Instructions for Use for more information.

If you connect an MMS from a monitor using a **Full** label set to an IntelliVue monitor using a **Restricted** label set or an M3/M4 monitor, any additional labels switch to labels available in the target monitor. This may cause a label conflict with other monitored measurements.

Be aware that connecting a monitor using the **Full** label set to an Information Center with certain software revisions may affect the availability of measurement information from the additional labels on the Information Center. See the Information Center documentation and your monitor's Configuration Guide for information on label set compatibility.

Resolving Label Conflicts

Each label must be unique, that is, it can only be assigned once. You cannot monitor two pressures labeled "ICP" at the same time. If you need to use two identical pressures, you must assign different labels to them, for example, P and ICP.

Measurement labels are stored in the measurement device (module or MMS). If you try to use two measurement devices that have identical labels, this causes a label conflict in the monitor.



Measurement selection key with question marks indicating a label conflict.

Depending on your configuration, the monitor will either

- resolve the conflict automatically, by assigning a new, generic label to the most recently connected conflicting label (e.g. a second FAP label could be changed to ABP)
- display the **Measurement Selection** window automatically for you to resolve the conflict
- take no action, you must enter the **Measurement Selection** window and resolve the conflict.

All the currently available measurement devices, for example MMSs, MMS extensions, measurement modules, Gas analyzers, devices connected to a host monitor and manually entered measurements

(marked , are depicted in the **Measurement Selection** window.

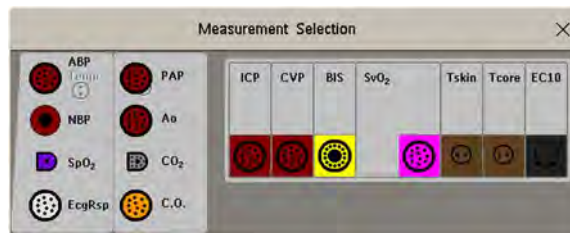

De-activated devices are grayed-out (here the Temp measurement on the left)

Any measurement labels causing a label conflict are shown in red. If a measurement device is connected but currently unavailable, for example, because it was deactivated due to a label conflict, the device is shown "grayed-out".

When an X2 is connected to a host monitor, the measurement selection window looks like this:



X2 connected to a host monitor

WARNING

When an X2 with an active measurement, say SpO₂, is connected to a host monitor with the same measurement already active, the SpO₂ measurement on the X2 is deactivated and the **Meas. Deactivated** INOP is displayed. The measurement can only be reactivated if the X2 is disconnected from the host monitor. The label conflict can be resolved on the host monitor like any other label conflict.

To resolve a label conflict:

- 1 Select the measurement selection key or select **Main Setup**, then **Meas. Selection** to display the **Measurement Selection** window.
- 2 Select the device whose label you want to correct.
- 3 Use the measurement selection pop-up keys to resolve the conflict. Select either:
 - **Change Label**: to assign a different label to the conflicting label.
 - **Activate**: to activate the highlighted measurement and deactivate the blinking measurement. This requires confirmation.
 - **De- Activate**: to disable the conflicting device. It retains its label for future use but becomes invisible to the monitor, as though it had been unplugged. When the device has been deactivated the question marks under the measurement selection key will be replaced by XXX.
 - **Setup <Measurement Label>**: to enter the Setup menu for the measurement and change the conflicting device's label to a different label.
 - **Modify Driver** (VueLink/IntelliBridge only): - to modify the device driver setup to disable the conflicting device's label.

Label Compatibility

When a new measurement is introduced, or new labels for an existing measurement, these labels will not be shown on older Information Centers, and consequently not on the Overview screen sourced from the Information Center.

When a patient is transferred from a monitor with these new labels to one with an older software revision, the labels will be replaced with a generic label for that measurement. The settings for that generic label will then be used.

If it is critical that the measurement labels are available at the Information Center and after transfers, the older monitors and the Information Center must be upgraded to the appropriate software revision.

Entering Measurements Manually

You can enter values into the monitor that have been measured with other equipment or manually (for example, manual temperatures, lab values). These values are then stored in the database, included in trends and reports, and passed on to the Information Center and central charting systems. There is no alarm functionality for manually entered measurements.

To enter values,

- 1 Select the **Enter Values** SmartKey or select **Main Setup** then select **Enter MeasValues**.
- 2 Select the measurement you want to enter values for. The Edit window will open.
- 3 If the measurement is switched off, switch it on by selecting the label.
- 4 Select **Value** and enter the value.
- 5 Select **Date/Time** to enter the date and time for the value. The default is always the current date and time.
- 6 For compound labels, for example **ABPs**, **ABPd** and **ABPm**, select the **Format** field to select whether all values are required or a single value.
- 7 Select **Save**.

When a manually entered value has been configured to display as a numeric on the screen, you can also enter a new value for this measurement by selecting the numeric, then selecting **Enter MeasValues**.

Manually entered measurement values are marked with a * on the display, in trends, and so forth. Each measurement has a defined measurement interval after which a value becomes invalid (no value is then displayed). Values can be entered up to two hours after they have been measured or up to the measurement interval, if this is shorter.

The list of measurement labels which appears in the **Enter Measurement Values** window is set in Configuration Mode.

Switching Manually Entered Measurements On and Off

To switch a manually entered measurement on or off,

- 1 Select the **Enter Values** SmartKey or select **Main Setup** then select **Enter MeasValues**.
- 2 Select the measurement you want to switch on or off.
- 3 Select the measurement label field to switch between **On** and **Off**.

Changing Monitor Settings

To change monitor settings such as brightness, or QRS tone volume, select the **Main Setup** permanent key and then select **User Interface** to enter a submenu where you can change these settings.

Adjusting the Screen Brightness

To adjust the brightness:

- 1 Select the **Brightness** SmartKey.



- 2 Select the appropriate setting for the screen brightness. 10 is the brightest, 1 is the least bright. **Optimum** is suitable for most monitoring locations and optimizes power usage for battery powered monitors.

The MX400/450/500/550 monitors can be configured to automatically adapt the screen brightness to the ambient light conditions. The range within which this adaptation is made is determined by the setting made with the **Brightness** SmartKey.

Your monitor may be configured with a lower brightness for Standby mode and also (for battery powered monitors) for transport to conserve battery power. These settings can only be changed in the monitor's Configuration Mode.

If you are using a monitor with an external display, the **Brightness** SmartKey does not adjust the brightness of this display. Refer to the documentation supplied with the external display for instructions.

Setting the Date and Time

- 1 Select the **Date, Time** screen element from the monitor's info line to enter the **Date, Time** menu.
- 2 Select, in turn, the **Year, Month, Day, Hour** (in 24 hour format, only) and **Minute** as necessary. Select the correct values from the pop-up list.
- 3 Select **Store Date, Time** to change the date and time.

If your monitor is connected to an Information Center, the date and time are automatically taken from this. Once it is set, the internal clock retains the setting even when you switch off the monitor.

WARNING

Changing the date or time will affect the storage of trends and events.

Checking Your Monitor Revision

- 1 Select **Main Setup** then select **Revisions** to open the **Monitor Revision** menu.
- 2 Select the correct device from the device pop-up keys.
- 3 From the **Monitor Revision** menu, select the monitor component for which you need revision information.

Getting Started

Once you understand the basic operation principles, you can get ready for monitoring. We also recommend working through the E-Learning Education Programs for self-training before using the monitor (available at the Philips Learning Center, english only).

Inspecting the Monitor

WARNING

If the monitor or mounting hardware is mechanically damaged, or if it is not working properly, do not use it for any monitoring procedure on a patient. Contact your service personnel.

- 1 Before you start to make measurements, carry out the following checks on the monitor including all connected MMSs, modules, or MMS extensions.
 - Check for any mechanical damage.
 - Check all the external cables, plug-ins and accessories.
- 2 Plug the power cord into the AC power source.
- 3 Check all the functions of the instrument that you need to monitor the patient, and ensure that the instrument is in good working order.

Setting up the Modules

- 1 Decide which measurements you want to make.
- 2 Connect the required modules, MMSs, or MMS extensions.
- 3 Check that you have the correct patient cables and transducers plugged in. The connectors are color-coded to the patient cables and transducers for easy identification.

Switching On

Press the power on/standby switch on the monitor for one second. The monitor performs a self test during which all lamps will light up and a tone will be sounded, and is then ready to use. If you see a message such as **CO₂ Sens Warmup** wait until it disappears before starting to monitor that measurement.

Connected devices usually take their power from the monitor. External devices such as gas monitors and those connected via VueLink/IntelliBridge have their own power switches.

Power On/Power Off Behavior

The general rules determining the behavior of the monitor when connected to, or disconnected from power are as follows:

- A monitor that was switched on prior to a temporary power loss switches on again when power is restored.
- A monitor that was switched off prior to a temporary power loss remains off when power is restored.
- When AC mains power is lost, a battery powered monitor continues to run without interruption on battery power.
- An MMS switches on automatically when connected to a running host monitor.
- When an X2 is disconnected from a running host monitor, the X2 continues to run without interruption on battery power.

Starting Monitoring

After you switch on the monitor,

- 1 Admit your patient to the monitor.
- 2 Check that the profile, alarm limits, alarm and QRS volumes, patient category and paced status and so forth are appropriate for your patient. Change them if necessary.
- 3 Refer to the appropriate measurement chapter for further details of how to perform the measurements you require.

WARNING

During MR imaging, remove all transducers, sensors and cables from the patient. Induced currents could cause burns.

Disconnecting from Power

The On/Standby switch does not disconnect the monitor from the ac power source. To disconnect, unplug the power cable.

Monitoring After a Power Failure

- A monitor that was switched on prior to a temporary power loss switches on again when power is restored.
- A monitor that was switched off prior to a temporary power loss remains off when power is restored.

If the monitor is without power for **less** than one minute, monitoring will resume with all active settings unchanged.

If the monitor is without power for **more** than one minute, the behavior depends on your configuration.

If **Automat. Default** is set to **Yes**, the default profile will be loaded when power is restored. If **Automat. Default** is set to **No**, all active settings are retained, if power is restored within 48 hours. The **Automat. Default** setting is made in Configuration Mode.

Networked Monitoring

You can connect your monitor to an Information Center on a network, using one of the optional interfaces:

- Standard wired LAN
- Wireless LAN
- IntelliVue Instrument Telemetry System (IIT).

WARNING

Only connect patient monitors to networks that conform to the network installation instructions provided by Philips for your system.

It is possible to assign additional monitoring equipment and a telemetry device to the same patient, resulting in the information from multiple devices being combined in one sector at the Information Center. (See “When Multiple Equipment is Used for One Patient” on page 122 and “Using a Telemetry Device and a Monitor (PIIC only)” on page 307.)

If your monitor is connected to a network, a network symbol is displayed in the upper left corner next to the bed label. To see details about the Care Group, the monitoring equipment, and technical information about the network, select the bed label in the monitor info line.

Be aware that some network-based functions may be limited for monitors on wireless networks in comparison to those on wired networks.

Printout functionality and data export are not guaranteed when using a standard hospital network.

Using the Integrated PC

MX600/ If your monitor has the optional integrated PC (iPC), you can run applications on the iPC. The
MX700/ applications display data on the monitor's display (or on a second independent display) that is
MX800 generated on and retrieved from the iPC or externally.

For details about applications, refer to the IntelliVue XDS Application Instructions for Use.

The monitor runs independently of the iPC, and vice versa.

WARNING

- Some clinical applications may show data from another patient. Be aware that some of the data on your patient monitor display may not always be from your patient.
 - Applications running on the iPC cannot act as a primary alarming device and cannot be relied upon for alarm notification. There may be no audible or visible indications apart from what is shown on the screen and any data shown may be delayed.
-

CAUTION

When you install any software on the iPC you are responsible for ensuring that the resulting system complies with all relevant local regulations.

Starting the iPC

Your monitor may be configured to have the iPC start up automatically when the monitor is switched on. If not:

- 1 Select **Main Setup** then **Internal PC**.
- 2 In the **Internal PC** menu, select **Switch PC on** to start the iPC.

Viewing the iPC Desktop on the Monitor Display

If the Desktop is not displayed on the monitor display:

- 1 Select the iPC key , or
- 2 Select **Main Setup**, **Internal PC**, then **Show PC Window**.

To hide the Desktop again, select **Main Screen**.

There are special iPC screens available that use the full height of the screen for the iPC Desktop. The monitoring screen content is then arranged on the right side of the screen. Such iPC screens may be loaded automatically when the iPC key is selected. In this case the **Main Screen** key is replaced by a **Previous Screen** key, to give you a fast and easy method to switch back and forth between the iPC screen and the regular screen.

Adjusting the iPC Audio Volume

The Audio from the iPC is normally configured to be off. However, your monitor may have the iPC audio configured on for use with specific PC applications.

WARNING

Always minimize the iPC audio volume or mute it completely when it is not needed for an iPC application. This will avoid iPC tones distracting from or masking tones from the monitor.

Using Input Devices with the iPC and Monitor

You can connect input devices such as a mouse, trackball and keyboard to the rear of the patient monitor (using the **left** hand row of USB connectors) and use them for input to the monitor. Correspondingly you can connect input devices to the rear of the patient monitor (using the **right** hand row of USB connectors) or to the front USB connector and use them for the iPC. Input devices connected to the iPC can also be shared with the patient monitor. Sharing input devices and touchscreen input requires a specific software application; refer to the IntelliVue XDS Application Instructions for Use for details.

If the iPC is switched off when input devices are shared, any input devices connected to it will not be available for use with the monitor.

Shutting the iPC Down

The iPC will be shut down automatically when the monitor is switched off.

If you want to shut down the iPC when the monitor is on,

- 1 Select **Main Setup** then **Internal PC**.
- 2 In the **Internal PC** menu, select **Switch PC off**.

If there is a problem with the shutdown, and you need to switch off the iPC manually,

- 1 Select **Main Setup** then **Internal PC**.
- 2 In the **Internal PC** menu, select **Force PC off** to force the iPC to power down.

Special Situations at Shutdown

- If you switch the monitor off and then on again immediately, the iPC will continue running and will not be shut down.
- In some situations, shutting down the iPC can take a little time. The monitor will go into Standby mode until the shutdown is complete. By touching the touchscreen, you can bring the monitor back into operating mode. If you do this, the iPC will restart when the shutdown is complete.
- If the shutdown cannot be completed within a certain time, a window will open giving the reason: for example, that a file has not been saved, or that updates are being installed. You can then decide whether to wait (for example, in the case of the updates) or to take action (for example by saving the unsaved file). You will also have the option to force shutdown, if necessary.

Using Your Monitor with a Monitor in Companion Mode

When you connect an X2 in companion mode to a host monitor, an integrated system is formed for monitoring a single patient. The following general observations and considerations apply to such a system:

- The host monitor is the "master" of the system, and you have full control over all the system's operation only via the host monitor.
- Functions you can operate on a monitor in companion mode are restricted to measurements originating in that device. If you try to operate controls that are disabled, you are prompted by the message **Not available in Companion Mode**.
- Depending on how it is configured, your host monitor can determine whether the user interface of a connected monitor in companion mode is completely disabled or not, and what is displayed on the screen (a standard main screen, or a blank screen indicating **Companion Mode**). This is controlled by two monitor settings that are applied to the monitor in companion mode on connection. You can change the settings in Configuration Mode.
- Global settings such as line frequency, QRS sound and ECG lead colors from the host monitor, are applied to the monitor in companion mode on connection. When disconnected from the host, the monitor in companion mode re-applies its own global settings.
- No audible alarms are available on a monitor in companion mode when connected to a host monitor. The only visual alarm indication is provided by the alarm lamps which are controlled by the host monitor. Alarms become active again as soon as the monitor in companion mode is disconnected from the host monitor.

- The host monitor is the master of all ADT information. ADT operations on the monitor in companion mode are disabled, and any pending actions on the monitor in companion mode (for example, admit or end case) are canceled.
- The date and time of the monitor in companion mode is synchronized with that of the host monitor.
- An X2 switches on automatically when connected to a running host monitor.
- When an X2 is disconnected from a running host monitor, the X2 continues to run without interruption on battery power.
- When an X2 is used with host monitors having different software revisions, be aware that functionality set up in a monitor with a newer revision will disappear when the X2 is connected to a monitor with an older revision without that functionality. For example, if an X2 is used with a revision H monitor and has been set up to alarm on Afib, this alarm will no longer exist when the X2 is connected to a revision G monitor. If you work in a mixed software environment, inform yourself about the differences between revisions by referring to the What's New chapter.
- Event surveillance in the monitor in companion mode is disabled. Main Setup menu operations and SmartKeys are disabled. While connected to a host monitor, no new events are detected in the monitor in companion mode, and no events are deleted. There is no transfer of stored events from the monitor in companion mode to the host monitor. After disconnection from the host monitor, event surveillance is enabled again in the monitor in companion mode, and new events are detected.

What's New?

This section lists the most important new features and improvements to the monitor and its user interface introduced with each release. Further information is provided in other sections of this book.

You may not have all of these features, depending on the monitor configuration purchased by your hospital.

What's New in Release K.1 (for MX400/450/500/550 only)

MX500/MX550

In this release the MX500/MX550 patient monitors join the IntelliVue monitor family. The monitors are optimized for transport within the hospital environment.

The MX500 has a 12-inch display and the MX550 has a 15-inch display. Both models have three integrated plug-in module slots for up to three measurement modules, or the IntelliBridge interface module (865115), or recorder module (M1116B/C). The MX500/550 have the option to be operated with a single, user-replaceable battery.

EC10 IntelliBridge Interface Board

MX400/450/500/550 The functionality of the IntelliBridge EC10 plug-in module - interfacing data from a connected external device into the monitor - is now available in an embedded board. The connector for the optional interface board is accessed at the rear of the monitor.

Wireless Remote Control

MX400/450/500/550 The remote control, previously only available with a USB cable connection, can now also be used wirelessly, with a short-range radio connection, as with the models MX600-800.

What's New in Release K.0

MX400/MX450

In this release the MX400/MX450 patient monitors join the IntelliVue monitor family. The monitors are optimized for transport within the hospital environment. The MX400 has a 9-inch display and the MX450 has a 12-inch display. Both monitors can optionally be equipped with an integrated recorder and have the option to be operated with a single user-replaceable battery.

What's New in Release J.0

Flexible, Patient-oriented Workflow (with PIIC iX only)

With the IntelliVue Information Center iX, more flexible, patient-oriented workflows are supported for admitting, tracking and transferring patients. This allows you to adapt monitor use to the patient data flow models in your specific facility and department.

Managing Patients

When the patient monitor is connected to an IntelliVue Information Center iX, an extended comparison of patient data allows more intelligent admission and transfer procedures. A **Find Patient** key can be used to search through the patient lists at the Information Center and other connected systems and take over the corresponding data found.

Flexible Transfer

A transfer can be initiated in the unit at the monitor, on patient arrival or patient departure, or centrally at the Information Center.

Managing Equipment

When used together with an Information Center iX, extended equipment management functionality is now available. Depending on how equipment is used in your facility, there are various ways to associate devices with patients, beds or monitors.

Additionally there are mechanisms to automatically free up equipment that is no longer used. Using the new **Equipment** window you have an overview of all equipment being used for a patient, together with patient and caregiver data.

New NMT Module

A new NMT module enables the evaluation of muscle relaxation of patients under Neuromuscular Block by measuring the strength of muscle reaction after electrically stimulating the dedicated motor nerve.

Alarm Functionality Enhancements

- **Pause Yellow Alarms (with PIIC iX only)** - up until now, the **Pause Alarms / Alarms Off** key switched off or paused all red and yellow alarms. Now an alarm priority configuration setting is available to have only yellow alarms affected.
- **Pause Alarms / Alarms Off** not allowed - when the alarm priority is set to **Not Allowed**, alarms can no longer be switched off or paused. The **Pause Alarms / Alarms Off** key is disabled.
- **Pause Alarms / Alarms Off** key can be removed from the screen - a configuration setting removes the permanent key from the screen to avoid unintentional switching off of alarms. Alarms can still be switched off or paused, in the **Alarms** menu, under **Main Setup**.
- **Alarms paused after Standby mode** - alarms are automatically paused for 1 minute after Standby mode to allow time for patient connection.

Capture 12-Lead ECG Enhancements (with PIIC iX only)

The existing 12-Lead ECG capture functionality has been extended to offer:

- Download of analysis results from the IntelliVue Information Center.
- Download of 12-Lead captures from the IntelliVue Information Center for review at the patient monitor.

- Analysis results included in reports and additional report selections with ST Map.
- Remote operation of the 12-Lead Export function at the IntelliVue Information Center.
- Remote operation of the 12-Lead Lock/Unlock function at the IntelliVue Information Center.
- New filter settings that are used as a default for future 12-Lead captures.

New "End Afib" and "End Irregular HR" Alarms

The end of an atrial fibrillation or irregular HR phase is announced with an **** End AFIB** or ****End Irregular HR** alarm. The delay time before the alarm is announced can be configured.

Information Line Changes

Patient Category is now displayed as a symbol in front of the patient name and cannot be changed from the Information line. Paced Mode is no longer displayed in the Information line; it appears next to the HR numeric.

Depending on your configuration, you will see the current Profile name, and/or the Screen name in the Information line. The Profiles menu has been simplified in Monitoring and Configuration Mode.

Sepsis Protocol Configurability

The SSC Sepsis protocol can now be configured, to customize it for the specific treatment measures used in your facility. This can include changes to limits for measured or manually entered values, changes to the Severe Sepsis Screening criteria, and changes to the recommendations in the Sepsis Resuscitation Bundle and the Sepsis Management Bundle.

Integrated Pulmonary Index for Microstream CO₂

An Integrated Pulmonary Index (IPI) numeric is provided, that is an indication of the patient's overall ventilatory status based on four measurement parameters: etCO₂, awRR, pulse rate and SpO₂.

Cardiac Output (transpulmonary method) - Changes to Calculation Basis for Extravascular Lung Water Index and Preload Indexes

EVLWI is now calculated using Ideal Body Weight (IBW). ITBVI and GEDVI are calculated using Ideal Body Surface Area (IBSA). IBW and IBSA are based on the patient category, gender and height that are entered for the patient.

Improved Visibility of Gridlines in Overlapping Waves

Visibility of the gridlines for overlapping waves has been improved, and you can now configure gridlines to be shown in white, if you prefer, in a thin or thick style.

Timeout for "Aged" Numerics

NBP and SpO₂ numerics from intermittent measurements can be configured to be grayed out or to disappear from the screen after a set time. This avoids older numerics being misinterpreted as current data. The time can be set individually for SpO₂ and NBP in Configuration mode.

Alarms

The alarm information here applies to all measurements. Measurement-specific alarm information is discussed in the sections on individual measurements.

The monitor has two different types of alarm: patient alarms and INOPs.

Patient Alarms

Patient Alarms are red and yellow alarms. A red alarm indicates a high priority patient alarm such as a potentially life threatening situation (for example, asystole). A yellow alarm indicates a lower priority patient alarm (for example, a respiration alarm limit violation). Additionally there are short yellow alarms, most of which are specific to arrhythmia-related patient conditions (for example, ventricular bigeminy).

INOPs

INOPs are technical alarms, they indicate that the monitor cannot measure or detect alarm conditions reliably. If an INOP interrupts monitoring and alarm detection (for example, **Leads Off**), the monitor places a question mark in place of the measurement numeric and an audible indicator tone will be sounded. INOPs without this audible indicator indicate that there may be a problem with the reliability of the data, but that monitoring is not interrupted.

Most INOPs are light blue, however there are a small number of INOPs which are always yellow or red to indicate a severity corresponding to red and yellow alarms. The following INOPs can also be configured as red or yellow INOPs to provide a severity indication:

- **ECG Leads Off**
- **NBP Cuff Overpress**
- **Cuff Not Deflated**
- **Occlusion**
- **<SpO₂ Label> No Pulse**
- **<Press Label> No Pulse**
- **Tele Disconnected**
- **Battery Empty / Replace Battery**

All monitors in a unit should have the same severity configured for these INOPs.

Alarm Delays

There is a delay between a physiological event at the measurement site and the corresponding alarm indication at the monitor. This delay has two components:

- **The general measurement delay time is the time between the occurrence of the physiological event and when this event is represented by the displayed numerical values.** This delay depends on the algorithmic processing and, for certain measurements (SpO₂, EEG and BIS), on the configured averaging time. The longer the averaging time configured, the longer the time needed until the numerical values reflect the physiological event.
- **The time between the displayed numerical values crossing an alarm limit and the alarm indication on the monitor.** This delay is the sum of the alarm delay configured for the specific measurement plus the system alarm delay. The system alarm delay is the processing time the system needs for any alarm on the monitor to be indicated after the measurement has triggered the alarm. See the performance specifications in the Specifications chapter for the system alarm delay specification.

The alarm delay configured for a specific measurement is normally a fixed time. For SpO₂ it is also possible to configure a Smart Alarm Delay that is calculated using an intelligent algorithm. See “Smart Alarm Delays” on page 195 in the SpO₂ chapter for more details.

Multiple Alarms

If more than one alarm is active, the alarm messages are shown in the alarm status area in succession. An arrow symbol next to the alarm message informs you that more than one message is active.

The monitor sounds an audible indicator for the highest priority alarm. If more than one alarm condition is active in the same measurement, the monitor announces the most severe. Your monitor may be configured to increase alarm indicator volume automatically during the time when the alarm is not acknowledged.

Visual Alarm Indicators

WARNING

- No alarms are available on an X2 when connected to a host monitor (**Companion Mode** is indicated). Alarms become active again as soon as the X2 is disconnected from the host monitor.
 - Alarm fields and other visual alarm indicators are disabled on an X2 when connected to a host monitor. The only visual alarm indication is provided by the alarm lamps, which are controlled by the host monitor.
-

Alarm Message

An alarm message text appears in the alarm status area at the top of the screen indicating the source of the alarm. If more than one measurement is in an alarm condition, the message changes every two seconds, and has an arrow (↑) at the side. The background color of the alarm message matches the alarm priority: red for red alarms, yellow for yellow alarms, light blue for standard INOPs, red for red INOPs and yellow for yellow INOPs. The asterisk symbols (*) beside the alarm message match the alarm priority: *** for red alarms, ** for yellow alarms, * for short yellow alarms. Standard INOPs do not have a symbol, red and yellow INOPs have exclamation marks beside the alarm message: !!! for red INOPs and !! for yellow INOPs.

Depending on how your monitor is configured, it may display alarm limit violation messages:

- in text form, for example **** SpO₂ Low** or
- in numeric form, for example ****Pulse xxx>yyy** where the first number shows the maximum deviation from the alarm limit, and the second number shows the currently set limit.

Flashing Numeric

The numeric of the measurement in alarm flashes.

Bright Alarm Limits

If the alarm was triggered by an alarm limit violation, the corresponding alarm limit on the monitor screen is shown more brightly if **Show AlarmLimits** is enabled and there is sufficient room on the screen.

Alarm Lamp

A lamp on the monitor's front panel flashes. The alarm lamp is divided into two sections. The right one flashes for a patient alarm, except for short yellow alarms where the lamp will light for approximately six seconds. The color is yellow or red corresponding to the highest priority patient alarm currently present. The left one lights continuously for a light blue INOP and flashes for yellow or red INOPs as follows:

INOP Lamp Color	On	Off
Yellow	1.0 seconds	1.0 seconds
Red	0.25 seconds	0.25 seconds

If only patient alarms are present, and no INOPs, the patient alarms will use both left and right sections to flash (for red and yellow alarms) or light for approximately six seconds (for short yellow alarms). If only INOPs are present, and no patient alarms, red and yellow INOPs will use both left and right sections to flash but light blue INOPs will always light continuously in the left section only.

MX400/450/500/550 If the screen brightness is configured to automatically adapt to ambient light conditions, the alarm lamps will also adapt their brightness accordingly.

Nurse Call Systems

If configured to do so, red, yellow and light blue alarms are indicated on any device connected to the nurse call relay.

Audible Alarm Indicators

The audible alarm indicators configured for your monitor depend on which alarm standard applies in your hospital. Audible alarm indicator patterns are repeated until you acknowledge the alarm by switching it off or pausing it, or until the alarm condition ceases (if audible alarm indication is set to non-latching).

WARNING

- Do not rely exclusively on the audible alarm system for patient monitoring. Adjustment of alarm volume to a low level or off during patient monitoring may result in patient danger. Remember that the most reliable method of patient monitoring combines close personal surveillance with correct operation of monitoring equipment.
- No audible alarm indicators are available on an X2 when connected to a host monitor (**Companion Mode** is indicated). Alarms become active again as soon as the X2 is disconnected from the host monitor.

Alarm Tone Configuration

The audible alarm indicators of your monitor are configurable. In the monitor's Configuration Mode, you can:

- increase the alarm volume of unacknowledged alarms at regular intervals
- change the interval between alarm sounds (ISO/IEC Standard alarms only)
- change the base volume of the red and yellow alarm tones and the INOP tones
- change the alarm sound to suit the different alarm standards valid in different countries.

Traditional Audible Alarms (HP/Agilent/Philips/Carenet)

- Red alarms and red INOPs: A high pitched sound is repeated once a second.
- Two-star yellow alarms and yellow INOPs: A lower pitched sound is repeated every two seconds.
- One-star yellow alarms (short yellow alarms): The audible indicator is the same as for yellow alarms, but of shorter duration.
- Standard INOPs: an INOP tone is repeated every two seconds.

ISO/IEC Standard Audible Alarms

- Red alarms and red INOPs: A high pitched tone is repeated five times, followed by a configurable pause.
- Two-star yellow alarms and yellow INOPs: A lower pitched tone is repeated three times, followed by a configurable pause.
- One-star yellow alarms (short yellow alarms): The audible indicator is the same as for yellow alarms, but of shorter duration.
- Standard INOPs: a lower pitched tone is repeated twice, followed by a pause.

Changing the Alarm Tone Volume

- The alarm volume symbol at the top right of the monitor screen gives you an indication of the current volume.



To change the volume, select the volume symbol and then select the required volume from the pop-up selection.

- If you want to see a numerical indication of the current alarm volume on a scale from zero to 10, or change the setting, select the **Alarm Volume** SmartKey.



The volume scale pops up. The current setting is indented. To change the setting, select the required number on the scale. Any settings that are inactive ("grayed out") have been disabled in the monitor's Configuration Mode.

- When the alarm volume is set to zero (off), the alarm volume symbol reflects this.



If you switch the alarm volume off, you will not get any audible indication of alarm conditions.

There is no alarm volume indication on the screen of an X2 when connected to a host monitor (**Companion Mode** is indicated).

Minimum Volume for No Central Monitoring INOP

If your monitor is connected to an Information Center, and the connection is interrupted, the INOP message **No Central Monit.** will appear within 30 seconds, accompanied by an INOP tone. To help ensure that this INOP, and any other active alarm, is not overlooked, the INOP and alarm tones may be configured to have a minimum volume. In this case, INOP and alarm tones will sound even if the monitor alarm volume is set to zero.

Minimum Volume for Severe Yellow or Red INOPs

Severe yellow or red INOPs require action to ensure the well-being of the patient. Therefore the minimum volume for the INOP tone is set to at least alarm volume 8, irrespective of the current alarm volume setting. The INOP tone will sound even if the monitor alarm volume is set to zero.

The severe INOPs for which this applies are:

Cuff Not Deflated (configurable to yellow or red)

NBP Cuff Overpress (configurable to yellow or red)

!! Insert Battery - X2 (yellow)

Battery Empty / Replace Battery - (configurable to light blue, yellow or red)

Power Loss Tone



When power is lost - no power is available via the power cable or battery (where available) - a buzzer will sound, if so configured. The tone can be silenced by pressing the On/Off power switch.

Acknowledging Alarms



To acknowledge all active alarms and INOPs, select the **Silence** permanent key. This switches off the audible alarm indicators and alarm lamps.

Alternatively, you can acknowledge alarms by pressing the **Silence** hardkey on the MMS or on the SpeedPoint. The hardkeys follow the behavior configured for the permanent key.

A check mark beside the alarm message indicates that the alarm has been acknowledged . If the monitor is configured to re-alarm, a dashed check mark will be shown .



If the condition that triggered the alarm is still present after the alarm has been acknowledged, the alarm message stays on the screen with a check mark symbol beside it, except for NBP alarms and alarms from other intermittent measurements. When such an alarm is acknowledged the alarm message disappears.

If the alarm condition is no longer present, all alarm indicators stop and the alarm is reset.

Switching off the alarms for the measurement in alarm, or switching off the measurement itself, also stops alarm indication.

Acknowledging Disconnect INOPs

Acknowledging an INOP that results from a disconnected transducer switches off the associated measurement, unless the monitor is configured to not allow this. The only exception is ECG/Resp: acknowledging a disconnect INOP for ECG leads does not switch off the ECG and Resp measurements. Acknowledging a disconnect INOP at the Information Center switches off the audible INOP indicator but does not switch off the measurement.

Unplugging an MMS or a plug-in module automatically switches off its measurements.

Alarm Reminder

If **Alarm Reminder** is configured on for your monitor, you will get an audible reminder of alarm conditions that remain active after you have acknowledged the alarm. This reminder may take the form of a repetition of the alarm tone for a limited time, or an unlimited repetition of the alarm tone (this is the same as a new alarm). **Alarm Reminder** is not available for standard, light blue INOPs but for yellow and red INOPs.

In Configuration Mode, you can set the interval between silencing the alarm and sounding the reminder tone to one, two, or three minutes.

The alarm reminder behavior at the Information Center is different to that at the monitor. Refer to the Information Center Instructions for Use for further information.

Pausing or Switching Off Alarms

If you want to temporarily prevent alarms from sounding, for example while you are moving a patient, you can pause alarms. Depending on your monitor configuration, alarms are paused for one, two, or three minutes, or infinitely. Infinite alarm pause is equivalent to switching the alarms off.

To view the alarm pause setting chosen for your unit,

- 1 Select **Main Setup, Alarms**, then **Alarm Settings**
- 2 Check the **Alarms Off** setting.

This setting can only be changed in Configuration Mode.

There are some settings made in Configuration Mode that can affect the availability of the pause alarms functionality.

- The **Pause Alarms / Alarms Off** permanent key can be removed from the screen to avoid unintentional switching off of alarms. The corresponding hardkey on the SpeedPoint or Navigation Point is then also disabled. In this case you can only pause alarms or switch alarms off permanently in the **Alarms** menu, under **Main Setup**.
- The **Pause Alarms / Alarms Off** permanent key and the corresponding hardkey can be configured to pause or switch off red and yellow alarms, yellow alarms only, or not to function at all. If they are configured not to function, you cannot pause alarms or switch alarms off permanently at all.

When the alarms off priority is set to **Yellow Only**, the **Pause Alarms / Alarms Off** key becomes the **Pause Yellow / Yellow Al. Off** key.

To Pause All Alarms



- Select the **Pause Alarms** permanent key. If your monitor is configured to infinite pause time, the permanent key is labeled **Alarms Off**, and selecting it switches alarms off.
- Or press the Alarms hardkey on the SpeedPoint or Navigation Point. The hardkey follows the behavior configured for the permanent key.

Depending on the configuration, you may need to select **Confirm** to complete the change.

To Switch All Alarms Off

You can only switch alarms off permanently if your monitor is configured to allow infinite alarms pause and the permanent key is labeled **Alarms Off** (or **Yellow Al. Off**).



- Select the **Alarms Off** (or **Yellow Al. Off**) permanent key.
- Or press the Alarms hardkey on the SpeedPoint or Navigation Point. The hardkey follows the behavior configured for the permanent key.

Depending on the configuration, you may need to select **Confirm** to complete the change.

To Switch Individual Measurement Alarms On or Off

- 1 Select the measurement numeric to enter its setup menu.
- 2 Select **Alarms** to switch between on and off.

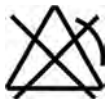

The alarms off symbol is shown beside the measurement numeric.

While Alarms are Paused or Off

When red alarms are paused or off:

- The red Alarms Paused lamp on the monitor front panel is lit.
In the alarm field, the monitor displays the message **Al. Paused x:yy** or **Alarms Off**, together with the alarms paused symbol or the alarms off symbol.

When yellow alarms are paused or off:

- The yellow Alarms Paused lamp on the monitor front panel is lit.
In the alarm field, the monitor displays the message **YellowPaused x:yy** or **Yellow Alarms Off**, together with the alarms paused symbol or the alarms off symbol.

For red and yellow alarms:

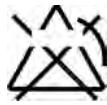

Alarms Paused



Alarms Off

- No alarms are sounded and no alarm messages are shown.
- INOP messages are shown but no INOP tones are sounded.
The only exceptions are the INOPs **Cuff Not Deflated**, **NBP Cuff Overpress** and INOPs relating to empty, missing and malfunctioning batteries.
These INOPs switch the alarms on, and the INOP tones are sounded, even if alarms are paused or off. You need to remove the INOP condition first before you can switch the alarm tones off again.
- The nurse call relay is not active.

If a disconnect INOP is present and alarms are paused or switched off, the measurement in question may be switched off, depending on monitor configuration.

Restarting Paused Alarms

To manually switch on alarm indication again after a pause, select the permanent key **Pause Alarms** (or **Alarms Off**) again.

Alarm indication starts again automatically after the pause period expires. If the monitor is configured to stay paused infinitely, you must select **Alarms Off** again to restart alarm indication.

Resetting Arrhythmia Alarm Timeouts

To reset the timeout period, either

- select the **Alarms Off** or **Pause Alarms** permanent key and then reselect it, or
- select **Reset Alarming** in the **Review Alarms** window or the **Alarm Messages** window.

Extending the Alarm Pause Time

If your monitor has extended alarm pause enabled, you can extend the alarm pause time. Use this to prevent alarms being indicated, for example, while you are washing a patient or carrying out a procedure. Only extend the alarm pause time when you are sure that clinical personnel are available to monitor the patient's condition closely.

To extend the alarm pause time to five or 10 minutes,

- 1 Select one of the alarm fields. This calls up the **Alarm Messages** window.
- 2 Select either the pop-up key **PauseAl. 5 min** or the pop-up key **PauseAl. 10 min**. Each time you select one of these pop-up keys, the Alarm Pause Time is reset to five (or 10) minutes.

Alarm Settings for Unattended Monitoring

When monitoring patients that are not continuously attended, use appropriate alarm settings to optimize monitoring:

- Always leave alarms switched on when the patient is unattended.
- Recommended configuration: Use one of the temporary settings for the **Alarms Off** setting, not **Infinite**, and make sure that the **AlarmOffReminder** and the **Alarm Reminder** are switched on (these settings are made in Configuration mode).
- Set alarm limits so that alarms will be triggered for those changes in the patient condition that you want to be advised of. Setting limits to very high or low values can render the alarm system useless.
- Use available notification routes, such as a nurse call system or the connection to an Information Center, or at least select an appropriate alarm volume to ensure that alarms are recognized.

Alarm Limits

The alarm limits you set determine the conditions that trigger yellow and red limit alarms. For some measurements (for example, BIS and SpO₂), where the value ranges from 100 to 0, setting the high alarm limit to 100 switches the high alarm off, or setting the low alarm limit to 0 switches it off. In these cases, the alarms off symbol is not displayed.

WARNING

Be aware that the monitors in your care area may each have different alarm settings, to suit different patients. Always check that the alarm settings are appropriate for your patient before you start monitoring.

Viewing Individual Alarm Limits

You can usually see the alarm limits set for each measurement next to the measurement numeric on the main screen.



If your monitor is not configured to show the alarm limits next to the numeric, or if the numeric is so small that the limits cannot be displayed, you can see them in the appropriate measurement setup menu. Select the measurement numeric to enter the menu and check the limits.

Viewing All Alarm Limits

The **Alarm Limits** overview window lists the currently set alarm limits for all measurements. If an Apnea alarm delay time is set, this is also shown. The alarms off symbol is shown beside the measurement label of any measurement whose alarm switched off.



To open the **Alarm Limits** window, either select any alarm field to open the **Alarm Messages** window, then select the **Alarm Limits** pop-up key, or select the **Alarm Limits** SmartKey, if configured.

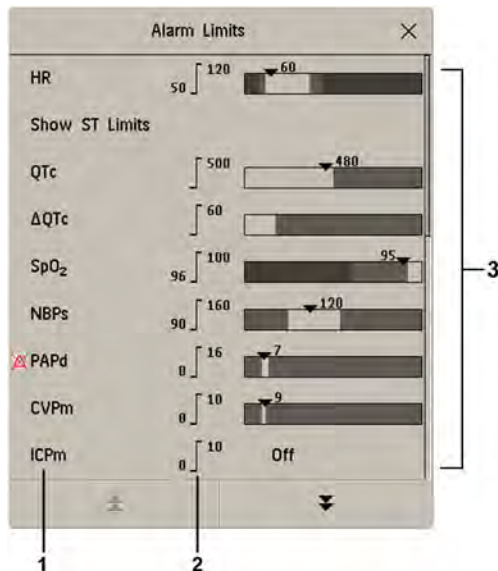

- 1 Measurement labels, with alarms off symbol where appropriate
 - 2 Current alarm limits
 - 3 Graphic view of current yellow and red alarm limits and currently monitored measurement value. **Off** indicates the measurement is switched off
- Select **Show ST Limits** to expand the list of ST leads and view the currently set alarm limits. Selecting **Hide ST Limits** hides the list again.

You can use the pop-up keys that open with the **Alarm Limits** window to perform common tasks:

- **All Al. On/All Al. Off**
- **All Lim. Narrow/All Lim. Wide** to set narrow or wide alarm AutoLimits for all measurements.
- **Print Limits/Record Limits** to print a list of all current alarm limit settings on a connected printer or recorder.

These pop-up keys are not available in the window for changing individual alarm limits which you access by selecting the measurement label in the **Alarm Limits** window.

Changing Alarm Limits

Set limits so that alarms will be triggered for those changes in the patient condition that you want to be advised of. Setting limits to very high or low values can render the alarm system useless.

To change individual measurement alarm limits using the measurement's Setup Menu,

- 1 In the measurement's setup menu, select the alarm limit you want to change. This calls up a list of available values for the alarm limit.

2 Select a value from the list to adjust the alarm limit.

Alternatively, you can use the keys in the measurement alarm limits window, which you access by selecting the measurement label in the **Alarm Limits** window.

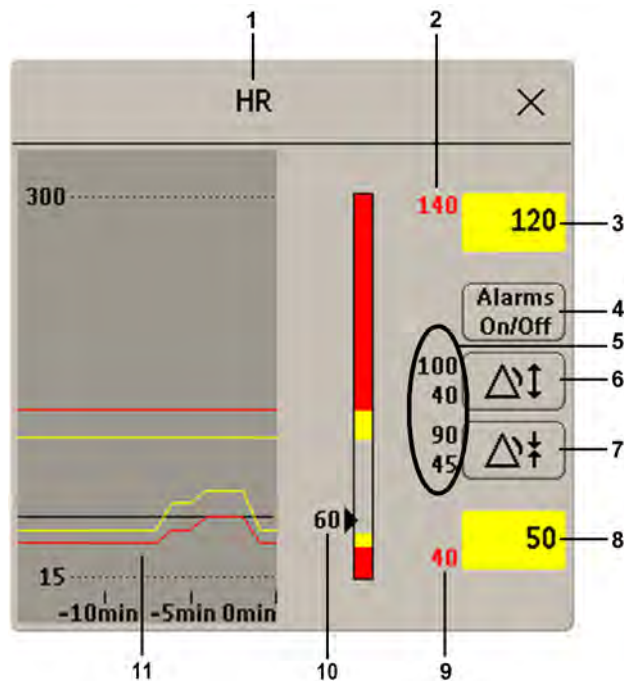

1	Parameter label
2	High red alarm limit (view only)
3	High yellow alarm limit field. Select to open a pop-up list of high alarm limits
4	Alarms On/Off key - select to switch between alarms on or off
5	Preview Alarm AutoLimits for a measurement before applying
6	Select to apply wide AutoLimits
7	Select to apply narrow AutoLimits
8	Low yellow alarm field. Select to open a pop-up list of low alarm limits
9	Low red alarm (view only)
10	Graphic view of alarm limits with currently measured value
11	15-min trend, showing alarm limits and monitored measurement values

To change alarm limits,

- 1 Enter the **Alarm Limits** window.
- 2 **Using touch:** to set the high alarm limit, select the high yellow alarm field to open a pop-up list of high alarm limits. Select a limit from the list. Repeat to set the low yellow alarm field.
Using a SpeedPoint or Navigation Point: position the cursor in the high yellow alarm field, then press the knob inwards. Rotate the knob to the left or right to adjust the limit. Press the knob again to set the displayed limit. Repeat to set the low yellow alarm limit.

If you set the yellow alarm limit outside the red alarm limit, the monitor will automatically adapt the red alarm limit.

When an ST measurement is in the alarm limits window there are also two pop-up keys available labeled **All ST Narrow/All ST Wide**. With these keys you can set Auto Limits for all ST Leads.

Alarm Limits can also be changed at the IntelliVue Information Center iX.

About Automatic Alarm Limits

The monitor can automatically set alarm limits suited to your individual patient, using the Automatic Alarm Limits function (AutoLimits). This tells the monitor to adapt the alarm limits of selected measurements to the measured vital signs within a defined safe limit. The monitor calculates safe AutoLimits for each patient based on the measured values from the last 12 seconds.

The wide and narrow limits have a fixed relationship to the measured value within the non-pathological range. Outside of this range, no auto limits are calculated. To set values outside of the non-pathological range, limits must be changed manually, based on the clinician's judgment about the specific patient.

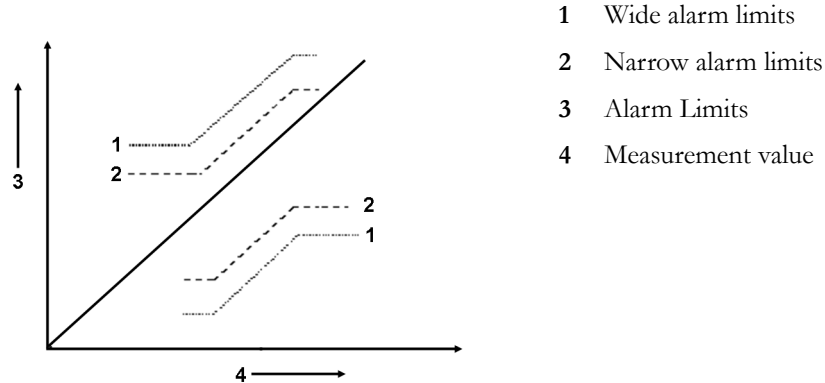

Limits Narrow sets limits close to the currently measured values for situations where it is critical for you to be informed about small changes in your patient's vital signs.

Limits Wide sets limits further away from the currently measured values for situations where small changes are not so critical.

Use the keys in the measurement alarm limits window to apply AutoLimits for individual measurements. These keys are not available if AutoLimits have been disabled for the measurement in the monitor's Configuration Mode.

AutoLimits are not available for all measurements. The list of measurements for which AutoLimits can be used is defined in the monitor's Configuration mode.

Use the measurement alarm limits window to check AutoLimits before you apply them to ensure that they are appropriate for your individual patient and their clinical condition. Once applied, AutoLimits are shown on the monitor screen just like manually-set alarm limits. If the AutoLimits are not appropriate for your patient, you must set alarm limits manually. The limits remain unchanged until you set them again or change them manually.

Documenting Alarm Limits

The alarm limits pop-up keys appear with the **Alarm Limits** and measurement alarm limits windows.

- Select the **Print Limits** pop-up key to print an overview of all alarm limits on a connected printer.
- Select the **Record Limits** pop-up key to send a recording of the alarm limits to a recorder.

Reviewing Alarms

You can see which alarms and INOPs are currently active in the respective alarms and INOPs fields at the top of the screen.

To see the currently active alarms and INOPs listed in one place, select any of the alarm status areas on the monitor screen. The **Alarm Messages** window pops up.

All alarms are erased from the **Alarm Messages** window when you discharge a patient, or if you change to Demonstration Mode.

Alarm Messages Window

The **Alarm Messages** window shows all the currently active alarms and INOPs sorted by priority, beginning at the top with the most recent. INOPs are shown on the left hand side and patient alarms are shown on the right hand side. Any active red alarms are shown first, followed by yellow alarms. Acknowledged alarms or INOPs are shown with the check mark symbol.

The **Alarm Messages** window pop-up keys appear when the window is opened. If alarm pause extension is disabled, the pause pop-up keys are inactive ("grayed-out"). Selecting the **Review Alarms** pop-up key opens the **Review Alarms** window.

If you do not immediately understand an INOP or alarm message, refer to its help text.

- In the **Alarm Messages** window, select the message. This calls up a help window with an explanation of the message and, where appropriate, a suggested solution for the problem.
- If the alarm or INOP was generated in a device other than the monitor (for instance, in an MMS or FMS), this source is specified at the end of the help text.

Review Alarms Window

The **Review Alarms** window contains a list of the most recent alarms and INOPs with date and time information.

If configured to do so, each alarm is shown with the alarm limit active when the alarm was triggered and the maximum value measured beyond this limit. The **Review Alarms** window also shows when the monitor was switched on (after being switched off for longer than 1 minute) and any actions related to switching device alarms on and off, entering or leaving Standby mode, silencing alarms or changing the ECG source.

When you select an item from the list, you can get additional information about that item. If you select a high or low limit alarm in the list, the **Graphical Trends** window will open to provide further data. If you select an alarm resulting from an event alarm notification, the **Event Episode** window for that event will open. If you select an alert other than a high or low alarm, a help text window opens with more information. This is the same as the help text window that opens in the **Alarm Messages** window. Some items in the list are simply log items not related to a patient alert as such (for example, **Alarms On** or **Alarms Off**). You cannot see any further information if you select one of these items. When you close these windows you will return to the **Review Alarms** window.

The information in the **Review Alarms** window is deleted when a patient is discharged, and when you leave Demonstration Mode.

The **Review Alarms** window pop-up keys appear when the window is opened. If alarm pause extension is disabled, the pause pop-up keys are inactive. Selecting the **Active Alarms** pop-up key opens the **Alarm Messages** window.

Latching Alarms

The alarm latching setting for your monitor defines how the alarm indicators behave when you do not acknowledge them. When alarms are set to non-latching, their indicators end when the alarm condition ends. Switching alarm latching on means that visual and/or audible alarm indications are still displayed or announced by the monitor after the alarm condition ends. The indication lasts until you acknowledge the alarm.

Viewing the Alarm Latching Settings

To see the alarm latching setting for your monitor

- 1 In the monitor's **Main Setup** menu, select **Alarms**.
- 2 Select **Alarm Settings**, and see the **Visual Latching** and **Audible Latching** settings.

This setting can only be changed in Configuration Mode. You should be aware of the settings chosen for your unit. There are three possible choices each for visual and audible latching, red only, red and yellow, and off. These choices can be combined to give the following settings:

Visual Latching	Audible Latching
Red&Yellow	Red&Yellow
Red&Yellow	Red Only
Red&Yellow	Off
Red Only	Red Only
Red Only	Off
Off	Off

Alarm Latching Behavior

Red & Yellow Measurement Alarms		Non-latching alarms	Visual and audible latching	Visual latching, audible non-latching
Alarm has not been acknowledged.	Alarm condition still present.	Alarm tone on. Alarm lamp on. Alarm message. Flashing numerics.	Alarm tone on. Alarm lamp on. Alarm message. Flashing numerics.	Alarm tone on. Alarm lamp on. Alarm message. Flashing numerics.
	Alarm condition no longer present.	All audible and visual alarm indicators automatically stop.	Alarm tone on. Alarm lamp on. Alarm message. Flashing numerics.	Alarm message. Flashing numerics. Audible alarm indicators automatically stop.
Alarm has been acknowledged.	Alarm condition still present.	Alarm tone off. Alarm lamp off. Alarm message. Flashing numerics. Audible alarm reminder (if configured).	Alarm tone off. Alarm lamp off. Alarm message. Flashing numerics. Audible alarm reminder (if configured).	Alarm tone off. Alarm lamp off. Alarm message. Flashing numerics. Audible alarm reminder (if configured).
	Alarm condition no longer present.	Audible and visual alarm indicators automatically stop.	Audible and visual alarm indicators automatically stop.	Audible and visual alarm indicators automatically stop.

All INOPs are non-latching. See “Yellow Arrhythmia Alarms” on page 160 for information on one-star yellow alarms latching behavior.

Testing Alarms

When you switch the monitor on, a selftest is started. You must check that the alarms lamps light, one after the other, and that you hear a single tone. This indicates that the visible and audible alarm indicators are functioning correctly. For further testing of individual measurement alarms, perform the measurement on yourself (for example SpO₂ or CO₂) or use a simulator. Adjust alarm limits and check that appropriate alarm behavior is observed.

Alarm Behavior at Power On

If the monitor is switched off for longer than one minute and then switched on again (or after a loss of power lasting longer than one minute, or when a patient is discharged), the monitor can be configured to:

- restore the alarm settings from the monitor's configured default Profile,
- restore the most recently used alarm settings, or
- switch the alarms off.

After any of these situations, you should check that the alarm settings are appropriate for your patient and monitoring situation, and if necessary, select the correct Profile and patient category.

If power is lost for less than one minute, the alarm on/off condition prior to the power loss is restored.

Alarm Recordings

You can set up your monitor so that it automatically triggers alarm recordings locally or at the Information Center, or if configured, to a printer as a realtime report.

- 1 Press the **Main Setup** SmartKey.
- 2 Select **Alarms** from the **Main Setup** menu.
- 3 Select **Alarm Recording** from the **Alarms** menu to open the **Alarm Recordings** menu.
- 4 Select a measurement from those listed for which you want to change the alarm condition that triggers an alarm recording. This opens a pop-up list.
- 5 For the desired measurement(s), choose the alarm condition to trigger an alarm recording:
 - Red Only:** an alarm recording will automatically be triggered when the measurement enters a red alarm condition.
 - Red&Yellow:** both yellow and red alarms will trigger an alarm recording.
 - Off:** disables automatic alarm recording.

Refer to the "Recording" chapter for details of how to set up a recording.

Patient Alarms and INOPs

This chapter lists patient alarms alphabetically, and technical alarms (INOPs) arranged by the source of the INOP and then alphabetically, irrespective of their priority. All alarms and INOPs are listed here; the ones which can appear on your monitor will depend on the model and the individual options.

Patient Alarm Messages

The measurement labels and abbreviations for pressure, temperature, SpO₂, and anesthetic agent alarms are explained in the individual chapters.

Some alarms may be shown at the Information Center in shortened form, when transferred through IntelliVue Instrument Telemetry. These shortened alarm texts are included in the list and identified with the note "at Information Center".

Refer to your IntelliBridge Device Driver Instructions for Use for patient alarms from connected external devices.

Refer to your Gas Module Instructions for Use for patient alarms and INOPs from the gas modules.

Refer to your IntelliVue TcG10 Instructions for Use for patient alarms and INOPs from the TcG10.

Alarm Message	From	Condition	Indication
* AFIB	ECG/Arrhythmia	Atrial fibrillation waveform detected	yellow alarm lamp, short yellow alarm tone
*** Apnea *** Apnea x:yy *** Apnea >10 min	CO ₂ , Resp, Spirometry	Respiration has stopped for longer than the preset apnea time. "x:yy" denotes the Apnea duration in minutes and seconds	numeric flashes, red alarm lamp, alarm tone
*** Asystole	ECG	No QRS detected for a period > the asystole alarm threshold	numeric flashes, red alarm lamp, alarm tone
** awRR High	CO ₂ , Resp, AGM	The airway respiration rate has exceeded the high alarm limit.	numeric flashes and high limit is highlighted, yellow alarm lamp, alarm tone
** awRR Low	CO ₂ , Resp, AGM	The airway respiration rate has dropped below the low alarm limit.	numeric flashes and low limit is highlighted, yellow alarm lamp, alarm tone
** BIS High	BIS	The Bispectral Index value has exceeded the high alarm limit.	numeric flashes and high limit is highlighted, yellow alarm lamp, alarm tone
** BIS Low	BIS	The Bispectral Index value has dropped below the low alarm limit.	numeric flashes and low limit is highlighted, yellow alarm lamp, alarm tone

4 Patient Alarms and INOPs

Alarm Message	From	Condition	Indication
***Brady/P xxx<yyy ***Brady xxx < yyy	Press, SpO ₂ ECG	This is the alternative alarm message for *** Extreme Brady , when the alarm text setting is Enhanced . Heart rate < the extreme bradycardia alarm limit. xxx denotes the lowest measured value; yyy is the extreme bradycardia limit.	numeric flashes and alarm limit is highlighted, red alarm lamp, alarm tone
** CCO High ** CCI High	CCO	Continuous Cardiac Output or CC Index is above the high alarm limit.	numeric flashes and high alarm limit is highlighted, yellow alarm lamp, alarm tone
** CCO Low ** CCI Low	CCO	Continuous Cardiac Output or CC Index is below the low alarm limit.	numeric flashes and low alarm limit is highlighted, yellow alarm lamp, alarm tone
** CPP High	CPP	The CPP value has exceeded the high alarm limit.	numeric flashes and high limit is highlighted, yellow alarm lamp, alarm tone
** CPP Low	CPP	The CPP value has fallen below the low alarm limit.	numeric flashes and low limit is highlighted, yellow alarm lamp, alarm tone
*** Desat *** Desat xx < yy	SpO ₂	The SpO ₂ value has fallen below the desaturation alarm limit. xx denotes the lowest measured value, and yy is the desaturation limit.	numeric flashes, red alarm lamp, alarm tone
** EC10 Alarm *** EC10 Alarm at Information Center	EC10 IntelliBridge	A yellow (**) or red (***) patient alarm is present on the IntelliBridge module. Check the monitor display for more detailed alarm information.	(on monitor) yellow or red alarm lamp; the alarm text is defined by the IntelliBridge device driver
* End AFIB	ECG/Arrhythmia	Atrial fibrillation no longer detected for the configured Afib end delay time	yellow alarm lamp, short yellow alarm tone
* End Irregular HR	ECG/Arrhythmia	Irregular HR no longer detected for the configured irregular HR end delay time.	yellow alarm lamp, short yellow alarm tone
** etCO₂ High	CO ₂ , AGM	The end tidal CO ₂ high alarm limit has been exceeded.	numeric flashes and high limit is highlighted, yellow alarm lamp, alarm tone
** etCO₂ Low	CO ₂ , AGM	The end tidal CO ₂ value has fallen below the low alarm limit.	numeric flashes and low limit is highlighted, yellow alarm lamp, alarm tone
** etO₂ High	O ₂ , AGM	The end tidal O ₂ high alarm limit has been exceeded.	numeric flashes and high limit is highlighted, yellow alarm lamp, alarm tone
** etO₂ Low	O ₂ , AGM	The end tidal O ₂ value has fallen below the low alarm limit.	numeric flashes, and low limit is highlighted, yellow alarm lamp, alarm tone
* Event ** Event *** Event at Information center	Event surveillance	An event has occurred and the event notification is configured to alarm. Check on the monitor for more details on event group.	(on monitor) event group name flashes, yellow or red alarm lamp and alarm tone
* Event:<Event Group> ** Event:<Event Group> *** Event:<Event Group>	Event surveillance	An event has occurred and the event notification is configured to alarm.	event group name flashes, yellow or red alarm lamp and alarm tone

Alarm Message	From	Condition	Indication
*** Extreme Brady	ECG	Heart rate < the extreme brady alarm limit.	numeric flashes and alarm limit is highlighted, red alarm lamp, alarm tone
*** Extreme Tachy	ECG	Heart rate > the extreme tachy alarm limit.	numeric flashes and alarm limit is highlighted, red alarm lamp, alarm tone
* HR High ** HR High	ECG	Heart rate > the high HR alarm limit	numeric flashes and high limit is highlighted, yellow alarm lamp, alarm tone. If configured to short yellow, the sound switches off after 5 seconds if Arrhythmia is switched on.
* HR Low ** HR Low	ECG	Heart rate < the low HR alarm limit	numeric flashes and low limit is highlighted, yellow alarm lamp, alarm tone. If configured to short yellow, the sound switches off after 5 seconds if Arrhythmia is switched on.
** IPI Low	CO ₂	The IPI value has fallen below the low alarm limit.	numeric flashes, and low limit is highlighted, yellow alarm lamp, alarm tone
* Irregular HR	ECG/Arrhythmia	Consistently irregular rhythm (irregular R-R intervals).	numeric flashes, yellow alarm lamp, short yellow audible alarm
** <iTemp Label> High	iTemp	The temperature value has exceeded the high alarm limit.	numeric flashes and high limit is high-lighted, yellow alarm lamp, alarm tone
** <iTemp Label> Low	iTemp	The temperature value has dropped below the low alarm limit.	numeric flashes and low limit is high-lighted, yellow alarm lamp, alarm tone
* Missed Beat	ECG/Arrhythmia	No beat detected for > 1.75*(the averaged R-R interval), or no beat detected for > one second if HR > 120 (For non-paced patients only).	numeric flashes, yellow alarm lamp, short yellow audible alarm
* More Alarms ** More Alarms *** More Alarms	other assigned devices	There is more than one physiological alarm of the corresponding severity active on the devices that monitor this patient. For details, check the information displayed at the Information Center.	yellow or red alarm lamp and alarm tone
* Multiform PVCs	ECG/Arrhythmia	Two different shaped Vs detected, each occurring at least twice within the last 300 beats and at least once within the last 60 beats.	numeric flashes, yellow alarm lamp, short yellow audible alarm
** NBP High	NBP	The measured NBP value is above the high alarm limit. s, d, or m after the label indicates whether the systolic, diastolic or mean pressure has crossed the limit.	numeric flashes and high limit is highlighted, yellow alarm lamp, alarm tone
** NBP Low	NBP	The measured NBP value is below the low alarm limit. s, d, or m after the label indicates whether the systolic, diastolic or mean pressure has crossed the limit.	numeric flashes and low limit is highlighted, yellow alarm lamp, alarm tone
* Non-Sustain VT	ECG/Arrhythmia	A run of PVCs < the V-Tach run limit and ventricular heart rate > the V-Tach HR limit	numeric flashes, yellow alarm lamp, short yellow audible alarm

4 Patient Alarms and INOPs

Alarm Message	From	Condition	Indication
* OtherMon Alarm ** OtherMon Alarm *** OtherMon Alarm	another assigned monitor	Another monitor used for the patient is in an alarm condition. Check the detailed alarm information at the Information Center.	yellow or red alarm lamp and alarm tone
* Pacer Not Capt	ECG/Arrhythmia (paced patients only)	No beat detected for > 1.75*(the averaged R-R interval) with detected pace pulse(s). (For paced patients only).	numeric flashes, yellow alarm lamp, short yellow audible alarm
* Pacer Not Pacing	ECG/Arrhythmia (paced patients only)	No beat and pace pulse detected for > 1.75*(the averaged R-R interval). (For paced patients only).	numeric flashes, yellow alarm lamp, short yellow audible alarm
* Pair PVCs	ECG/Arrhythmia	Two ventricular beats between two non-ventricular beats.	numeric flashes, yellow alarm lamp, short yellow audible alarm
* Pause	ECG/Arrhythmia	No beat detected for a period > the pause threshold.	numeric flashes, yellow alarm lamp, short yellow audible alarm
*** <Press Label> Disconnect	PRESS	The pressure is non-pulsatile and the mean pressure is continuously less than 10 mmHg (1.3 kPa). This alarm occurs only with arterial pressures (P, ABP, ART, Ao, BAP, FAP, PAP, UAP, P1, P2, P3, P4).	numeric flashes, red alarm lamp, alarm tone
*** <Press Label> High	PRESS	The measured pressure value is above the extreme high alarm limit. s, d, or m after the label indicates whether the systolic, diastolic or mean pressure has crossed the limit.	numeric flashes, high limit is highlighted, red alarm lamp, alarm tone
** <Press Label> High	PRESS	The measured pressure value is above the high alarm limit. s, d, or m after the label indicates whether the systolic, diastolic or mean pressure has crossed the limit.	numeric flashes, high limit is highlighted, yellow alarm lamp, alarm tone
*** <Press Label> Low	PRESS	The measured pressure value is below the extreme low alarm limit. s, d, or m after the label indicates whether the systolic, diastolic or mean pressure has crossed the limit.	numeric flashes and low limit is highlighted, red alarm lamp, alarm tone
** <Press Label> Low	PRESS	The measured pressure value is below the low alarm limit. s, d, or m after the label indicates whether the systolic, diastolic or mean pressure has crossed the limit.	numeric flashes and low limit is highlighted, yellow alarm lamp, alarm tone
** Pulse High	PRESS, SpO ₂	The pulse rate has exceeded the high alarm limit.	numeric flashes and high limit is highlighted, yellow alarm lamp, alarm tone
** Pulse Low	PRESS, SpO ₂	The pulse rate has dropped below the low alarm limit.	numeric flashes and low limit is highlighted, yellow alarm lamp, alarm tone
* PVCs/min High	ECG/Arrhythmia	PVCs detected within a minute > the alarm limit	numeric flashes, yellow alarm lamp, short yellow audible alarm
** QTc High	ECG/QT	QTc value has exceeded the QTc high limit for more than 5 minutes	numeric flashes, yellow alarm lamp, alarm tone
** ΔQTc High	ECG/QT	ΔQTc value has exceeded the ΔQTc high limit for more than 5 minutes	numeric flashes, yellow alarm lamp, alarm tone

Alarm Message	From	Condition	Indication
* R-on-T PVCs	ECG/Arrhythmia	For HR < 100, a PVC with R-R interval < 1/3 the average interval followed by a compensatory pause of 1.25*(the average R-R interval), or two such Vs without compensatory pause occurring within 5 minutes of each other. (When HR > 100, 1/3 R-R interval is too short for beat detection)	numeric flashes, yellow alarm lamp, short yellow audible alarm
** RR High	RESP	The respiration rate has exceeded the high alarm limit.	numeric flashes and high limit is highlighted, yellow alarm lamp, alarm tone
** RR Low	RESP	The respiration rate has dropped below the low alarm limit.	numeric flashes and low limit is highlighted, yellow alarm lamp, alarm tone
* Run PVCs High	ECG/Arrhythmia	A run of > 2 PVCs.	numeric flashes, yellow alarm lamp, short yellow audible alarm
** <SO₂ Label> High	SvO ₂ /SO ₂	The the measured intravascular oxygen saturation has exceeded the high limit.	numeric flashes and high alarm limit is highlighted, yellow alarm lamp, alarm tone
** <SO₂ Label> Low	SvO ₂ /SO ₂	The measured intravascular oxygen saturation has fallen below the low limit.	numeric flashes and low alarm limit is highlighted, yellow alarm lamp, alarm tone
** <SpO₂ Label> High	SpO ₂	The arterial oxygen saturation has exceeded the high alarm limit.	numeric flashes and high limit is highlighted, yellow alarm lamp, alarm tone
** <SpO₂ Label> Low	SpO ₂	The arterial oxygen saturation has fallen below the low alarm limit.	numeric flashes and low limit is highlighted, yellow alarm lamp, alarm tone
**ST Multi <n>, <n>	ECG/ST	Two contiguous ST leads <n> and <n> have exceeded elevation or depression limits for more than 60 seconds. The limit violations for both leads must be with respect to same limit; either both above the high limit or both below the low limit.	numeric flashes, yellow alarm lamp, alarm tone
**ST Multi at Information Center	ECG/ST	The ST depression or elevation is outside of the limit in two or more leads. Check on the monitor	(on monitor) numeric flashes, yellow alarm lamp, alarm tone
**STE <n>, <n>	ECG/ST	Two contiguous leads <n> and <n> are above their respective STE limits	numeric flashes, yellow alarm lamp, alarm tone
** ST-<n> High	ECG/ST	The ST elevation in lead <n> is higher than the limit. Lead is not contiguous with any other lead.	numeric flashes and high alarm limit is highlighted, yellow alarm lamp, alarm tone
** ST-<n> Low	ECG/ST	The ST depression in lead <n> is lower than the limit. Lead is not contiguous with any other lead.	numeric flashes and low alarm limit is highlighted, yellow alarm lamp, alarm tone
* SVT	ECG/Arrhythmia	A run of supraventricular beats > the SVT run limit and heart rate > the SVT HR limit.	numeric flashes, yellow alarm lamp, alarm tone

4 Patient Alarms and INOPs

Alarm Message	From	Condition	Indication
***Tachy/P xxx>yyy or ***Tachy xxx > yyy	Press, SpO ₂ , ECG	This is the alternative alarm message for *** Extreme Tachy when the alarm text setting is Enhanced . Heart rate >the extreme tachycardia alarm limit. xxx denotes the highest measured value; yyy is the tachycardia limit.	numeric flashes, alarm limit is highlighted, red alarm lamp, alarm tone
** Tblood High	C.O.	The blood temperature value has exceeded the high alarm limit.	numeric flashes, high alarm limit is highlighted, yellow alarm lamp, alarm tone
** Tblood Low	C.O.	The blood temperature value has fallen below the low alarm limit.	numeric flashes, low alarm limit is highlighted, yellow alarm lamp, alarm tone
** tcpO₂ High ** tcpCO₂ High	tcGas	The tcpO ₂ or tcpCO ₂ value has exceeded the high alarm limit.	numeric flashes, high alarm limit is highlighted, yellow alarm lamp, alarm tone
** tcpO₂ Low ** tcpCO₂ Low	tcGas	The tcpO ₂ or tcpCO ₂ value has fallen below the low alarm limit.	numeric flashes, low alarm limit is highlighted, yellow alarm lamp, alarm tone
* Tele Alarm ** Tele Alarm *** Tele Alarm	an assigned telemetry device	A telemetry device used for the patient is in an alarm condition. Check the detailed alarm information at the Information Center.	yellow or red alarm lamp and alarm tone
** <Temp Label> High	TEMP	The temperature has exceeded the high alarm limit.	numeric flashes and high limit is highlighted, yellow alarm lamp, alarm tone
** <Temp Label> Low	TEMP	The temperature has fallen below the low alarm limit.	numeric flashes and low limit is highlighted, yellow alarm lamp, alarm tone
* T-Mon Alarm ** T-Mon Alarm *** T-Mon Alarm	an assigned transport monitor	A transport monitor used for the patient is in an alarm condition. Check the detailed alarm information at the Information Center.	yellow or red alarm lamp and alarm tone
** TOFcnt High	NMT	TOFcnt value has exceeded the high alarm limit	numeric flashes and high limit is highlighted, yellow alarm lamp, alarm tone
* Vent Bigeminy	ECG/Arrhythmia	A dominant rhythm of N, V, N, V (N = supraventricular beat, V=ventricular beat)	numeric flashes, yellow alarm lamp, short yellow audible alarm
*** Vent Fib/Tach	ECG	Fibrillatory waveform (sinusoidal wave between 2 – 10 Hz) for 4 consecutive seconds.	numeric flashes, red alarm lamp, alarm tone
* Vent Rhythm ** Vent Rhythm	ECG/Arrhythmia	A dominant rhythm of adjacent Vs > the vent rhythm limit and ventricular heart rate < the V-Tach HR limit.	numeric flashes, yellow alarm lamp, short yellow audible alarm
* Vent Trigeminy	ECG/Arrhythmia	A dominant rhythm of N, N, V, N, N, V (N = supraventricular beat, V = ventricular beat).	numeric flashes, yellow alarm lamp, short yellow audible alarm
*** VTach	ECG, Arrhythmia	A run of PVCs ≥ the V-Tach run limit and heart rate > the V-Tach HR limit.	numeric flashes, red alarm lamp, alarm tone
** VueLink Alarm *** VueLink Alarm at Information Center	VueLink	A yellow (**) or red (***) patient alarm is present on the VueLink module. Check the monitor display for more detailed alarm information.	(on monitor) yellow or red alarm lamp; the alarm text is defined by the VueLink device driver

Technical Alarm Messages (INOPs)

If an INOP interrupts monitoring and alarm detection, the measurement numeric will be replaced by **-?-**. If an INOP may lead to unreliable measurement values, a **?** appears next to the numeric.

The measurement labels and abbreviations for pressure, temperature, SpO₂, and VueLink INOP messages are explained in the individual measurement chapters.

Monitor INOPs

INOP Message, Indication	What to do
Bad MSL INOP tone	1) An MMS with an incompatible software revision is connected to the monitor. This combination does not allow monitoring, OR 2) You cannot use this combination of monitor, MMS and cable. Switch off the monitor and contact your service personnel.
Central: Tele Only INOP tone	System connectivity via telemetry device is limited (No alarms, only local numerics) when in companion mode and host monitor does not have system connectivity. Only telemetry device parameters can be displayed at central station.
Check Alarm Lamps INOP tone	Perform a visual check of the alarm lamp to establish whether there is a problem. Contact your service personnel to check the internal connections to the alarm lamps.
Check DrugSettings INOP tone	There was a problem loading the drug settings. Check that the settings are complete and correct.
!!Check ECG Source Yellow tone	The telemetry device and the monitor both have valid ECG signals. Unpair the telemetry device and the monitor if they are no longer used for the same patient.
!! Check Equipment INOP tone/Yellow tone	There is an equipment status dispute relating to one or more of the devices assigned to this patient. See the Equipment window for details.
Check Flex Texts INOP tone	Check the names of the monitor menus, for example the labels for screens, profiles, event or trend group names, before you resume monitoring. If they are unexpected, there may be a problem with the monitor software. Contact your service personnel.
Check Keyboard INOP tone	Perform a visual and functional check of the keyboard. Contact your service personnel.
Check Main Board 2 INOP tone	There is a problem with the second main board in the monitor. Contact your service personnel.
Check Monitor Func INOP tone	Potential problem with alarm lamps, display or interfaces detected. Contact your service personnel.
Check Monitor Temp INOP tone	The temperature inside the monitor is too high. Check that the monitor ventilation is not obstructed. If the situation continues, contact your service personnel.
Check Mouse INOP tone	Perform a visual and functional check of the mouse input device. Contact your service personnel.
Check MSL Voltage INOP tone	There is a problem with the voltage of the Measurement Link (MSL). Contact your service personnel.
Check Network Conf INOP tone	The monitor is receiving network topology information from more than one source, e.g. the Database Server and an Application Server. Contact your service personnel.
!! Check Pairing Yellow tone	There is a problem with device pairing. Check that the monitor and telemetry device are correctly paired.
!!Check Patient ID Yellow tone	There is a mismatch between patient data in two connected devices. Resolve the mismatch to allow settings and data synchronization.

4 Patient Alarms and INOPs

INOP Message, Indication	What to do
Check Screen Res. INOP tone	The Screen you have selected uses a resolution which is not supported by the display. The monitor will show a generic Screen instead until you select a different Screen. Contact your service personnel if you want the Screen deleted from the Profile(s) to avoid this in future.
Check Settings INOP tone	If this INOP appears, check the monitor and patient settings before you resume monitoring. If the settings are unexpected, there may be a problem with the monitor software. Contact your service personnel.
Check SpeedPoint INOP tone	Perform a visual and functional check of the SpeedPoint input device. Contact your service personnel.
Check Touch Input INOP tone	Perform a visual and functional check of the touch input device. Contact your service personnel.
Check Waves INOP tone	The options purchased with this monitor may not support the number of waves required to show the selected Screen, so some waves or high resolution trends are missing from the Screen. Select a different Screen with fewer waves. Contact your service personnel if you want the Screen deleted from the Profile(s) to avoid this in future.
Chk ECG Sync Cable INOP tone	The ECG Sync is detecting an invalid signal, or the ECG Sync cable is disconnected.
Chk IndepDsp Cable	The monitor cannot communicate with the D80 Intelligent Display. Check the MSL coupling cable. The end with the gray connector must be connected to the Intelligent Display.
Chk <Measurement Label>Settings	Synchronization of the settings for the measurement cited, has failed. Check that settings are appropriate for your patient.
Chk MSL Connection INOP tone	Check that the MSL cable is properly connected. If this is the case, try using another MSL cable, to check if your cable is defective. If this does not help, the device connected via the MSL cable may be defective, contact your service personnel.
Internal.Comm.Malf INOP tone	There is a problem with I2C Bus communication in the monitor. Contact your service personnel.
MCC Reversed INOP tone	The MSL coupling cable is reversed. Connect the end with the gray connector to the Intelligent Display.
MCC Unsupported INOP tone	An MSL coupling cable has been connected to a device which does not support MSL coupling.
Meas. Deactivated	An X2 or MP5 has been connected to a host monitor (companion mode) and all derived measurements have been deactivated and/or measurements with a label conflict. The measurements can only be reactivated by disconnecting the measurement device from the host monitor.
!!More Bed Alarms !!!More Bed Alarms at Information Center	The monitor is associated with a telemetry device and is sending data to the Information Center via the telemetry device. There are currently more alarms at the bedside than can be transmitted to the Information Center.
More INOPs !! More INOPs !!! More INOPs	There is more than one technical alarm of the corresponding severity active on the devices that monitor this patient. For details check the information displayed at the Information Center.
MSL Power High	The power consumption of the devices connected to the Measurement Link (MSL) cable is too high. If this situation continues, the MSL will be switched off. Contact your service personnel.
MSL Power Off INOP tone	The power consumption of the devices connected to the Measurement Link (MSL) cable was too high for too long and the MSL has been switched off. Contact your service personnel.
MSL Power Overload INOP tone	The power consumption of the devices connected to the Measurement Link (MSL) cable is much too high or there has been a short circuit. The MSL has been switched off. Contact your service personnel.

INOP Message, Indication	What to do
No Central Monit. INOP tone	There is a problem with the communication to the network. Central monitoring is currently not possible (no patient alarms or information). Check the connection. In case the connection is via a telemetry device, the current telemetry use model does not support central monitoring. Contact your service personnel.
No ECG at Central	The ECG measured with the monitor ECG is not being sent to the Information Center via the telemetry device.
OtherMon INOP !! OtherMon INOP !!! OtherMon INOP	Another monitor assigned to the patient (e.g. a transport monitor) is in an INOP condition. Check the detailed INOP information at the Information Center and resolve the INOP condition(s) at the other monitor.
Rem.AlarmDev.Malf. INOP tone	There is a problem with the connection to the remote alert device. Contact your service personnel to check the remote alert device and its connections.
Settings Malfunc INOP tone	The monitor cannot use the predefined settings for monitoring. Contact your service personnel.
Speaker Malfunc INOP tone	Contact your service personnel to check the speaker and the connection to the speaker.
SRR Incompatible INOP tone	The short range radio component has compatibility problems. Contact your service personnel.
SRR Interference INOP tone	The short range radio connection has interference from another device. Try using another channel.
SRR Invalid Chan INOP tone	The channel configuration of the Short Range Radio is invalid. Check channel and channel mask configuration.
SRR Malfunction INOP tone	Malfunction in the short range radio device. If the INOP persists contact your service personnel.
TAAP Disabled INOP tone	The currently selected telemetry configuration on the monitor does not allow connection of telemetry devices to the monitor.
Tele Config Unsupp INOP tone	Telemetry Workflow configuration not supported. Check revision and configuration of monitor and central.
Tele ECG Malfunc. Numeric is displayed with a -?- INOP tone	Contact your service personnel. The ECG in the Telemetry device is faulty.
Tele Equip Malf INOP tone	The telemetry device has a malfunction. Disconnect and reconnect the telemetry device. If the INOP reappears, replace the telemetry device.
Tele Incompatible	SRR-enabled telemetry device is not supported by this central software revision. Please check configuration.
Tele INOP !! Tele INOP !!! Tele INOP	A telemetry device assigned to the patient is in an INOP condition. Check the detailed INOP information at the Information Center and resolve the INOP condition(s) at the telemetry device.
Tele Unsupported INOP tone	This telemetry device is not supported for direct connection to the monitor.
TimeExpired:<Timer Label> INOP tone	The time has expired for the timer indicated in the INOP text. Clearing the timer clears the INOP.
T-Mon INOP !! T-Mon INOP !!! T-Mon INOP INOP tone	A transport monitor assigned to the patient is in an INOP condition. Check the detailed INOP information at the Information Center and resolve the INOP condition(s) at the transport monitor.
TransportEquipment	The equipment is ready for transport. See the Equipment window for details.

4 Patient Alarms and INOPs

INOP Message, Indication	What to do
Unsupported LAN INOP tone	There is a problem with the communication to the network and central monitoring is currently not possible. Check the connection. If the INOP persists, switch off the monitor and contact your service personnel.
User I/F Malfunc INOP tone	Perform a visual and functional check of all the monitor input devices. Contact your service personnel.

Battery INOPs

INOP Message, Indication	What to do
Batt 1 Missing Batt 2 Missing INOP tone During this INOP, alarms cannot be paused or switched off.	The monitor requires two batteries but can detect only one battery. Insert the missing battery immediately.
Batt Empty !!Batt Empty !!!Batt Empty INOP tone, battery LED flashes During this INOP, alarms cannot be paused or switched off.	The estimated remaining battery-powered operating time is less than 10 minutes. Replace the battery immediately. If the condition persists and the monitor is not connected to mains power, this INOP is re-issued two minutes after you acknowledge it.
Batt Extensn Malf INOP tone	There is a hardware error in the Battery Extension. Contact your service personnel.
Batt Incompat INOP tone	The battery cannot be used with this monitor. Replace with the correct battery as specified in this book.
Batt Low INOP tone	The estimated battery-powered operating time remaining is less than 20 minutes.
Batt Malfunction INOP tone, battery LED flashes During this INOP, alarms cannot be paused or switched off unless the monitor is connected to mains power.	The monitor cannot determine the battery status. If this INOP persists, replace the faulty battery. If the condition persists and the monitor is not connected to mains power, this INOP is re-issued two minutes after you acknowledge it. Place the battery in a different monitor or in a battery charger. If the same INOP is shown, contact your service personnel.
Batteries Empty !!Batteries Empty !!!Batteries Empty Batt 1 Empty !!Batt 1 Empty !!!Batt 1 Empty Batt 2 Empty !!Batt 2 Empty !!!Batt 2 Empty INOP tone, battery LED flashes During this INOP, alarms cannot be paused or switched off.	The estimated remaining battery-powered operating time of the indicated battery or batteries is less than 10 minutes. Replace the batteries immediately. If the condition persists and the monitor is not connected to mains power, this INOP is re-issued two minutes after you acknowledge it.
Batteries Incompat Batt 1 Incompat Batt 2 Incompat INOP tone	The indicated battery or batteries cannot be used with this monitor. Replace with the correct battery or batteries as specified in this book.
Batteries Low Batt 1 Low Batt 2 Low INOP tone	The estimated battery-powered operating time remaining is less than 20 minutes.

INOP Message, Indication	What to do
Batteries Malfunc Batt 1 Malfunction Batt 2 Malfunction INOP tone, battery LED flashes During this INOP, alarms cannot be paused or switched off unless the monitor is connected to mains power.	The monitor cannot determine the battery status. If this INOP persists, replace the faulty battery or batteries. If the condition persists and the monitor is not connected to mains power, this INOP is re-issued two minutes after you acknowledge it. Place the batteries in a different monitor or in a battery charger. If the same INOP is shown, contact your service personnel.
Charge Batt 1 now Charge Batt 2 now INOP tone	Battery must be charged. Connect the monitor to mains power or exchange the battery.
Charger Malfunc INOP tone, battery LED may flash	There is a problem with the battery charger in the monitor. Connect the monitor to mains power and contact your service personnel.
Check Batt Temp INOP tone	The temperature of one or both batteries is too high. Check that ventilation openings (if applicable) are not blocked and monitor is not exposed to heat.
Chk MSL Connection	Check the MSL connection between X2/MP2 and the battery extension for damage or loose connections. Check also if a second X1 or X2 has been connected accidentally (e.g. in companion mode).
ExtBat Empty !!ExtBat Empty !!!ExtBat Empty INOP tone, battery LED flashes During this INOP, alarms cannot be paused or switched off.	The estimated battery-powered operating remaining time is less than 10 minutes. Replace the battery in the battery extension immediately. If the condition persists and the monitor is not connected to mains power, this INOP is re-issued two minutes after you acknowledge it.
ExtBat Incompat	The battery in the battery extension cannot be used. Replace with the correct battery as specified in this book.
ExtBat Low	The estimated battery-powered operating time remaining is less than 20 minutes.
ExtBat Malfunction INOP tone, battery LED flashes During this INOP, alarms cannot be paused or switched off unless the monitor is connected to mains power.	The monitor cannot determine the status of the battery in the battery extension. If this INOP persists, replace the faulty battery in the battery extension. If the condition persists and the monitor is not connected to mains power or a host monitor, this INOP is re-issued two minutes after you acknowledge it.
ExtBat Missing	There is no battery in the Battery Extension
!! Insert Battery Severe yellow INOP tone During this INOP, alarms cannot be paused or switched off.	X2/MP2 only: There is no battery in the battery compartment. You cannot operate the monitor on AC mains or battery extension while the battery compartment is open (not sealed with a battery). Load a battery immediately.
MSL Power High	The power consumption of the devices connected to the Battery Extension is too high. If this situation continues, the Battery Extension will be switched off. Contact your service personnel.
MSL Power Off	The power consumption of the devices connected to the Battery Extension was too high for too long. The Battery Extension has been switched off. Contact your service personnel.

MMS, MMS Extensions and FMS INOPs

INOP Message, Indication	What to do
FMS Unplugged INOP tone	Make sure that the Flexible Module Rack is connected to the monitor. All FMS measurements are off while the FMS is unplugged.

4 Patient Alarms and INOPs

INOP Message, Indication	What to do
FMS Unsupported INOP tone	The Flexible Module Rack is not supported by your monitor. Contact your service personnel.
MMS Ext. Unplugged INOP tone	The MMS extension has been disconnected from the Multi-Measurement Module.
MMS Ext. Unpowered INOP tone	The MMS extension cannot operate while the Multi-Measurement Module is running on battery power.
MMS Ext. Unsupp INOP tone	The MMS extensions not supported by your monitor. Contact your service personnel.
MMS Ext. Equip Malf INOP tone	Loss of communication between the Multi-Measurement Module and the MMS extension. Contact your service personnel.
MMS Unplugged INOP tone	Make sure that the Multi-Measurement Module is connected to the monitor. All MMS measurements are off while the MMS is unplugged.
MMS Unsupported INOP tone	The Multi-measurement Module is not supported by your monitor. Contact your service personnel.
MMS/FMS Unsupported INOP tone	The Multi-Measurement module is not supported by the monitor. Contact your service personnel.
No PPV from FMS	The measurement device does not supply a beat-to-beat arterial pressure value. Contact your service personnel.
No PPV from MMS	The measurement device does not supply a beat-to-beat arterial pressure value. Contact your service personnel.

Display INOPs

INOP Message, Indication	What to do
Indep.Dsp Malfunc.	There is a problem with the Independent Display. Check the MSL coupling cable then contact your service personnel.
Indep.Dsp NotSupp.	The monitor does not support a second main display. The monitor software is incompatible. Contact your service personnel.
Intell.Dsp Malf.	There is a problem with the Intelligent Display. Check the MSL coupling cable then contact your service personnel.
Intell.Dsp Missing	The monitor has lost contact with the connected Intelligent Display. Contact your service personnel.
Intell.Dsp Unsupp.	The monitor does not support the connected Intelligent Display. The monitor software is incompatible.

ECG, Arrhythmia, QT and ST INOPs

INOP Message, Indication	What to do
C Lead Off HR Numeric is replaced by -?- for 10 seconds. INOP tone	The C electrode (AAMI: V electrode) has become detached from the patient or the lead set has been changed. Reattach the electrode or select New Lead Setup in the Setup ECG menu to confirm the new lead set.
Cannot Analyze ECG	The arrhythmia algorithm cannot reliably analyze the ECG data. Check the ECG signal quality of the selected primary and secondary leads. If necessary, improve lead position or reduce patient motion. If you have arrhythmia analysis on, and you are not getting a reliable HR because the signal is below a minimum amplitude, unstable, or contains artifact, and you have tried to improve the system performance by choosing another lead and changing electrodes, you should consider turning arrhythmia analysis off.

INOP Message, Indication	What to do
Cannot Analyze QT	The QT algorithm cannot generate a valid QT value for more than 10 minutes, or 1 minute in the initial phase.
Cannot Analyze ST	The ST algorithm cannot generate a valid ST value. Possible causes are large variations in the measured ST values for consecutive beats, or ventricular paced beats. Review the ECG signal quality and the ST measurement points. If the patient has a ventricular pacemaker, ST analysis is not possible.
Cannot Analyze STE	The STE algorithm cannot generate valid ST elevation values. Possible causes are large variations in the measured ST values for consecutive beats, or ventricular paced beats. Review the ECG signal quality and the ST measurement points.
ECG Equip Malf Numeric is replaced by -?- INOP tone	Contact your service personnel. The ECG hardware is faulty.
<ECG Lead> Lead Off !! <ECG Lead> Lead Off !!! <ECG Lead> Lead Off Numeric is replaced by -?- INOP tone	Not all the required leads for ECG monitoring are connected. Check the ECG connections and make sure that the electrode indicated by <ECG lead> [RA, LA, LL, RL, V or C] electrodes is attached. In EASI mode, all 5 electrodes must be connected.
ECG Leads Off !! ECG Leads Off !!! ECG Leads Off Numeric is replaced by -?- INOP tone	Check that all of the required ECG leads are attached, and that none of the electrodes have been displaced. The INOP may also be caused by a saturated or overloaded ECG amplifier.
ECG Noisy Elec <ECG Lead>	The ECG signal from the named ECG electrodes [RA, LA, LL, RL, V (or C)] is noisy. Check the ECG connections and make sure that the electrode indicated is attached.
ECG Noisy Signal INOP tone	The ECG signal is too noisy. Check that the electrodes are properly placed and have not dried out. Remove any possible sources of signal noise (such as power cords) from the area around the cable and the patient. The ECG signal may be saturated or overloaded.
ECG Out Equip Malf INOP tone	There is a problem with the device connected to the ECG Out connector. Contact your service personnel.
!!ECG/Ar AlarmsOff	All ECG alarms have been switched off, or the HR alarm source is not ECG. To resume ECG alarm generation, switch ECG alarms on or select ECG as the alarm source.
ECG/Arrh AlarmsOff !!ECG/Ar AlarmsOff	All ECG alarms have been switched off, or the HR alarm source is not ECG. To resume ECG alarm generation, switch ECG alarms on or select ECG as the alarm source.
LA Lead Off Numeric is replaced by -?- for 10 seconds. INOP tone	The LA electrode has become detached from the patient or the lead set has been changed. Reattach the electrode or select New Lead Setup in the Setup ECG menu to confirm the new lead set.
LL Lead Off Numeric is replaced by -?- for 10 seconds. INOP tone	The LL electrode has become detached from the patient or the lead set has been changed. Reattach the electrode or select New Lead Setup in the Setup ECG menu to confirm the new lead set.
RA Lead Off Numeric is replaced by -?- INOP tone	The RA electrode has become detached from the patient or the lead set has been changed. Reattach the electrode or select New Lead Setup in the Setup ECG menu to confirm the new lead set.
RL Lead Off Numeric is replaced by -?- for 10 seconds. INOP tone	The RL electrode has become detached from the patient or the lead set has been changed. Reattach the electrode or select New Lead Setup in the Setup ECG menu to confirm the new lead set.
Some ECG AlarmsOff	This message appears (if configured to do so) when the on/off settings of the yellow arrhythmia alarms differ from the current Profile.

4 Patient Alarms and INOPs

INOP Message, Indication	What to do
V Lead Off Numeric is replaced by -?- for 10 seconds. INOP tone	The V electrode (IEC: C electrode) has become detached from the patient or the lead set has been changed. Reattach the electrode or select New Lead Setup in the Setup ECG menu to confirm the new lead set.

Pulse INOPs

INOP Message, Indication	What to do
Pulse Not Alarming Numeric is replaced by -?- INOP tone	Pulse has no alarming because the system pulse is measured by an external device. Select another pulse source to enable pulse alarming.

Resp INOPs

INOP Message, Indication	What to do
Resp Equip Malf Numeric is replaced by -?- INOP tone	Contact your service personnel. The RESP hardware is faulty.
Resp Erratic Numeric is replaced by -?-	The monitor has detected too many artifacts in the measured Resp signal. Check that the RA and LL electrodes are correctly attached and have not dried out.
Resp Leads Off Numeric is replaced by -?- INOP tone	Not all the required leads for Resp monitoring are attached. Make sure that the RA and LL leads are attached.

NBP INOPs

INOP Message, Indication	What to do
!! Cuff Not Deflat !!!Cuff Not Deflat Numeric is displayed with a -?- Severe yellow/red INOP tone During this INOP, alarms cannot be paused or switched off.	Remove the cuff from the patient. Make sure that the tubing is not kinked or twisted and that the correct patient category is selected. Try repeating the measurement. You can silence the INOP, but the INOP message remains visible until the next NBP measurement is started or the Stop All SmartKey is selected. [Adult or pediatric patients: The NBP cuff pressure has exceeded 15 mmHg (2 kPa) for more than 3 minutes. Neonatal patients: The NBP cuff pressure has exceeded 5 mmHg (0.7 kPa) for more than 90 seconds.]
!! Cuff Overpress !!!Cuff Overpress Numeric displayed with a -?- Severe yellow/red INOP tone During this INOP, alarms cannot be paused or switched off.	The NBP cuff pressure exceeds the overpressure safety limits. Remove the cuff from the patient. Make sure that the tubing is not kinked or twisted and that the correct patient category is selected. Try restarting the measurement. You can silence this INOP, but the INOP message remains visible until the next measurement is started or the Stop All SmartKey is selected.
NBP Deactivated INOP tone	The NBP measurement label in the measurement device has been deactivated by deactivating the label in the Measurement Selection window. The measurement automatically disappears from the display. To switch the measurement on again, reactivate the measurement label in the Measurement Selection window.
NBP Equip Malf Numeric is replaced by -?- INOP tone	Remove the cuff from the patient. The NBP hardware is faulty. Contact your service personnel. You can silence this INOP, but the INOP message remains visible until the next measurement is started or the Stop All SmartKey is selected.

INOP Message, Indication	What to do
NBP Interrupted Numeric is replaced by -?- INOP tone	Check the tubing and cuff for leakages or kinks. Check that you are using the correct cuff size and placement, and that the correct patient category is selected. Try restarting the measurement. If the INOP occurs repeatedly, contact your service personnel. You can silence this INOP, but the INOP message remains visible until the next measurement is started or the Stop All SmartKey is selected. This INOP arises when the measurement needed longer than the maximum time for inflation, deflation or the total measurement.
NBP Measure Failed Numeric may be displayed with a -?- INOP tone	Check that you are using the correct cuff size and placement, and that the correct patient category is selected. Try restarting the measurement. You can silence this INOP, but the INOP message remains visible until the next measurement is started or the Stop All SmartKey is selected. Check the condition and suitability of the patient for NBP monitoring. Use another cuff to continue measuring.

Temperature INOPs

INOP Message, Indication	What to do
T1, T2, T3, T4 INOPs	See <Temp Label> INOPs
Tamb INOPs	See <Temp Label> INOPs
Tart INOPs	See <Temp Label> INOPs
Tcereb INOPs	See <Temp Label> INOPs
Tcore INOPs	See <Temp Label> INOPs
<Temp Label> Deactivated INOP tone	A Temp measurement label in the measurement device has been deactivated, either by connecting a Pressure transducer in the shared Press/Temp socket, or by deactivating the label in the Measurement Selection window. The measurement automatically disappears from the display. To switch the measurement on again, either reconnect a Temp transducer or reactivate the measurement label in the Measurement Selection window.
<Temp Label> Equip Malf Numeric is replaced by -?- INOP tone	Contact your service personnel. The temperature hardware is faulty.
<Temp Label> NoTransducer Numeric is replaced by -?- INOP tone	Make sure the TEMP probe is connected to the MMS or module. If you silence this INOP, the measurement will be switched off.
<Temp Label> Overrange Numeric is replaced by -?- INOP tone	Try changing the application site of the transducer. [The temperature is less than -1°C, or greater than 45°C.]
<Temp Label> Unplugged INOP tone	A Temp measurement label has been deactivated, either by unplugging a module, or by deactivating the label in the Measurement Selection window. The measurement automatically disappears from the display. To switch the measurement on again, either replug the module or reactivate the measurement label in the Measurement Selection window.
Tesoph INOPs	See <Temp Label> INOPs
Tnaso INOPs	See <Temp Label> INOPs
Trect INOPs	See <Temp Label> INOPs
Tskin INOPs	See <Temp Label> INOPs
Ttymp INOPs	See <Temp Label> INOPs

4 Patient Alarms and INOPs

INOP Message, Indication	What to do
Tven INOPs	See <Temp Label> INOPs
Tvesic INOPs	See <Temp Label> INOPs

SpO₂ INOPs

INOP Message, Indication	What to do
<SpO ₂ Label> Chk Sensor	The condition of the signal at the SpO ₂ sensor is not as expected. Accuracy may be compromised. Check proper application of the sensor in accordance with the Instructions for Use. If the INOP persists, consider exchanging the sensor.
<SpO ₂ Label> Deactivated INOP tone	The SpO ₂ measurement label in the measurement device has been deactivated by deactivating the label in the Measurement Selection window. The measurement automatically disappears from the display. To switch the measurement on again, reactivate the measurement label in the Measurement Selection window.
<SpO ₂ Label> Equip Malf Numeric is replaced by -?- INOP tone	The MMS or module is faulty. Unplug and replug the MMS or module. If the INOP persists, contact your service personnel.
<SpO ₂ Label> Erratic Numeric is replaced by -?- INOP tone	Check the sensor placement. Try another adapter cable and sensor. If the INOP persists, contact your service personnel.
<SpO ₂ Label> Extd.Update Numeric is replaced by -?- (questionable numeric)	The update period of displayed values is extended due to an NBP measurement on the same limb or an excessively noisy signal.
<SpO ₂ Label>Interference Numeric is replaced by -?- INOP tone	There is too much interference, caused by a high level of ambient light and/or electrical interference. Cover the sensor to minimize ambient light. If the INOP persists, make sure that the sensor cable is not damaged or positioned too close to power cables.
<SpO ₂ Label> Low Perf Numeric is replaced by -?- (questionable numeric)	Accuracy may be compromised due to very low perfusion. Stimulate circulation at sensor site. If INOP persists, change the measurement site.
<SpO ₂ Label> No Pulse Numeric is replaced by -?- INOP tone	Check the perfusion at measurement site. If necessary, stimulate circulation or change measurement site. If the INOP is due to NBP measurement on the same limb, wait until the NBP measurement is finished.
<SpO ₂ Label> No Sensor Numeric is replaced by -?- INOP tone	Make sure the SpO ₂ sensor is connected. If the INOP persists, try another adapter cable and sensor. If you silence this INOP, the measurement will be switched off.
<SpO ₂ Label> NoisySignal Numeric is replaced by -?- INOP tone	Excessive patient movement or electrical interference is causing irregular pulse patterns. Try to reduce patient movement or to relieve the cable strain on the sensor.
<SpO ₂ Label> Poor Signal Numeric is replaced by -?- (questionable numeric)	The signal condition of the SpO ₂ measurement is poor and measurement accuracy may be compromised. If the INOP persists, consider changing the application site or using another sensor.
<SpO ₂ Label> Pulse? Numeric is replaced by -?- INOP tone	The detectable pulsations of the SpO ₂ signal are outside the specified pulse rate range.
<SpO ₂ Label> Searching Numeric unavailable	SpO ₂ is analyzing the patient signal to derive Pulse, SpO ₂ and Perf values. Please wait until the search analysis is complete.
<SpO ₂ Label> Sensor Malf Numeric is replaced by -?- INOP tone	The SpO ₂ sensor or adapter cable is faulty. Try another adapter cable and sensor. If the INOP persists, contact your service personnel.

INOP Message, Indication	What to do
<SpO₂ Label> Sensor Off Numeric is replaced by -?- INOP tone	The SpO ₂ sensor is not properly applied to the patient. Apply the sensor following the instructions supplied by the manufacturer.
<SpO₂ Label> Unkn.Sensor Numeric is replaced by -?-	The connected sensor or adapter cable is not supported by the SpO ₂ measurement. Use only specified sensors and cables.
<SpO₂ Label> Unplugged Numeric is replaced by -?- INOP tone	An SpO ₂ measurement label has been deactivated, either by unplugging a module, or by deactivating the label in the Measurement Selection window. The measurement automatically disappears from the display. To switch the measurement on again, either replug the module or reactivate the measurement label in the Measurement Selection window.
<SpO₂ Label> Upgrade Numeric is replaced by -?- Numeric is unavailable	The SpO ₂ measurement is currently in upgrade mode. Monitoring is not possible in this mode.

Pressure INOPs

INOP Message, Indication	What to do
ABP INOPs	See <Press Label> INOPs
Ao INOPs	See <Press Label> INOPs
ART INOPs	See <Press Label> INOPs
BAP INOPs	See <Press Label> INOPs
CPP Chk Sources Numeric is replaced by -?- INOP tone	Not all measurements or values required to perform the calculation are available. Check the measurement sources.
CPP Chk Units Numeric is replaced by -?-	The monitor has detected a conflict in the units used for this calculation. Check the unit settings.
CPP Disabled	CPP has been disabled, either in the setup in Configuration mode, or by loading settings with CPP disabled. This can happen when changing from a pediatric or neonatal profile to an adult profile, as the default profile settings have the CPP measurement disabled in the adult profile and enabled in the pediatric and neonatal profiles. Enable CPP in the current profile to clear the INOP.
CVP INOPs	See <Press Label> INOPs
FAP INOPs	See <Press Label> INOPs
IC1 / IC2 INOPs	See <Press Label> INOPs
ICP INOPs	See <Press Label> INOPs
LAP INOPs	See <Press Label> INOPs
P / P1 / P2 / P3 / P4 INOPs	See <Press Label> INOPs
PAP INOPs	See <Press Label> INOPs
PPV bad <Press Label> Signal	The arterial pressure source selected for PPV is not providing a pulsatile signal.
PPV bad Signal at Information Center	The arterial pressure source selected for PPV is not providing a pulsatile signal.
PPV Chk Sources	The arterial pressure source selected for PPV is unplugged or switched off. When this INOP has displayed for 1 minute PPV will be switched off.
<Press Label> Artifact Numeric questionable	A non-physiological event (flush or blood sample) is detected. A resulting limit alarm or non-pulsatile INOP will be suppressed.

4 Patient Alarms and INOPs

INOP Message, Indication	What to do
<Press Label> Deactivated INOP tone	A Pressure measurement label in the measurement device or extension has been deactivated, either by connecting a Temp transducer in the shared Press/Temp socket, or by deactivating the label in the Measurement Selection window. The measurement automatically disappears from the display. To switch the measurement on again, either reconnect a Pressure transducer or reactivate the measurement label in the Measurement Selection window.
<Press Label> Equip Malf Numeric is replaced by -?- INOP tone	Contact your service personnel. The pressure hardware is faulty.
<Press Label> No Pulse Pulse numeric is replaced by -?- INOP tone	This INOP can only arise when a pressure is selected as the pulse source. It occurs when the pulse rate being measured is less than 25 beats per minute or the amplitude is less than three mmHg. Check the catheter and connections to the patient.
<Press Label> No Transducer Numeric is replaced by -?- INOP tone	Make sure that the pressure transducer is connected to the measurement device or module. If you silence this INOP, the measurement will be switched off.
<Press Label> Noisy Signal Pulse numeric is replaced by -?- INOP tone	This INOP can only arise when a pressure is selected as the pulse source. It occurs when the pulse detector finds a pulse rate above 350 bpm. This is usually caused by movement artifact or electrical interference.
<Press Label> Overrange Numeric is replaced by -?- INOP tone	Make sure that the measurement has been properly prepared and zeroed, and that the transducer is level with the heart. If this INOP persists, try another transducer. Possible causes are a measured pressure outside the allowed pressure range, or a broken wire to the transducer.
<Press Label> Reduce Size	Increase the scale for the pressure wave.
<Press Label> Unplugged INOP tone	A Pressure measurement label has been deactivated, either by unplugging a module, or by deactivating the label in the Measurement Selection window. The measurement automatically disappears from the display. To switch the measurement on again, either replug the module or reactivate the measurement label in the Measurement Selection window.
<Press Label> Zero+Check Cal Numeric is replaced by -?-	Perform a zero and check the calibration of the transducer.
RAP INOPs	See <Press Label> INOPs
UAP INOPs	See <Press Label> INOPs
UVP INOPs	See <Press Label> INOPs

CO2 INOPs

INOP Message, Indication	What to do
CO₂ Auto Zero Numeric is replaced by -?- if the Autozero lasts >15 sec, INOP tone sounds.	The automatic zero calibration is in progress. This typically takes 10 seconds. During this time the CO ₂ values may not be updated, or they may be replaced by -?-. Wait until the zero calibration is complete to resume monitoring.
CO₂ Cal Failed Numeric is replaced by -?- INOP tone	Make sure that the Cal cell was changed between CAL1 and CAL2. Repeat the calibration. If the INOP reappears, try another transducer. If the INOP persists, contact your service personnel.

INOP Message, Indication	What to do
CO₂ Cal Mode CO ₂ numeric displays current CO ₂ value for accuracy check	Currently no calibration is running. Accuracy can be checked by placing the transducer on the two cells of the calstick and starting calibration. To start monitoring, leave Cal. Mode.
CO₂ Cal Running Numeric is replaced by -?-	Wait until calibration is finished.
CO₂ Check Cal Numeric is replaced by -?- INOP tone	The CO ₂ value is outside the measurement range. Perform an accuracy check for both calstick cells and, if necessary, recalibrate the transducer.
CO₂ Chk Adapter Numeric is replaced by -?- INOP tone	Check that the sensor is connected to the airway adapter, clean the airway adapter, if necessary. Perform a zero calibration. If the INOP persists, contact your service personnel.
CO₂ Deactivated INOP tone	The CO ₂ measurement label in the measurement device has been deactivated by deactivating the label in the Measurement Selection window. The measurement automatically disappears from the display. To switch the measurement on again, reactivate the measurement label in the Measurement Selection window.
CO₂ Equip Malf Numeric is replaced by -?- INOP tone	The Measurement Extension is faulty. Unplug and replug the Multi-Measurement Module with Extension. If you are using the mainstream method, unplug and replug the transducer or try another transducer. If the INOP persists, contact your service personnel.
CO₂ No Sensor from M3014A Numeric is replaced by -?- INOP tone	There is no CO ₂ sensor connected. If you silence this INOP the CO ₂ measurement will be switched off.
CO₂ No Tubing Numeric is replaced by -?- INOP tone	Either the sample line is disconnected, or an incorrect line is attached. Check the connection. If necessary, connect another sample line (Use only the approved accessories). If you silence this INOP, the measurement will be switched off.
!! CO₂ Occlusion !!! CO₂ Occlusion Numeric is replaced by -?- INOP tone	The sample line or exhaust tube is blocked. Check the tubing, then disconnect and reconnect the sample line. If the INOP persists, connect a new sample line.
CO₂ Overrange Numeric is replaced by -?- INOP tone	The CO ₂ value is higher than the measurement range. If you suspect a false high value, contact your service personnel.
CO₂ Pump Off Numeric is replaced by -?-.	The pump has been switched off for fifteen minutes. To switch it on again, select Pump On in the Setup CO₂ menu.
CO₂ Purging Numeric is replaced by -?- INOP tone	The Filterline is being purged to remove an occlusion in the line or airway adapter. If the occlusion is removed, the INOP will disappear. If not, the INOP CO₂ Occlusion is displayed.
CO₂ Sens Warmup Numeric is replaced by -?- Microstream CO ₂ : INOP tone Mainstream CO ₂ : no INOP tone	Wait until the sensor reaches operating temperature and the INOP disappears.
CO₂ Upgrade FW- Numeric is replaced by -?- INOP tone	The software in the Measurement Extension does not match the software in the MMS. Contact your service personnel.
CO₂ Wait Cal2 Numeric is replaced by -?-	Calibration on the first calstick cell is complete. Place the transducer on the other calstick cell and start the CAL2 calibration cycle.
CO₂ Zero Failed Numeric is replaced by -?- INOP tone	An error occurred during the last zero calibration. Check the airway adapter and clean, if necessary. Perform another zero calibration. If the INOP persists, contact your service personnel.
CO₂Change Scale	The CO ₂ wave is clipped. Select a more appropriate wave scale to display the whole wave.

4 Patient Alarms and INOPs

INOP Message, Indication	What to do
CO₂NoTransducer from mainstream CO ₂ (except M3014A) Numeric is replaced by -?- INOP tone	There is no CO ₂ transducer connected. If you replace the transducer, the new transducer must be calibrated. If you silence this INOP the CO ₂ measurement will be switched off.
CO₂Zero Running	Wait until zero calibration is finished.
CO₂ZeroRequired Numeric is replaced by -?- INOP tone	Perform zero calibration for the CO ₂ sensor. If the INOP persists, contact your service personnel.
IPI Check Pat. Age	For Adult patients: a date of birth has been entered that results in a calculated patient age of less than 12 years. Enter correct date of birth or, if patient is pediatric, correct patient category. For pediatric patients: either no date of birth has been entered (it is required for calculation of IPI for pediatric patients) or the calculated age is below 1 year or above 12 years. Check that correct date of birth is entered.
IPI Check Sources	The IPI numeric cannot be provided as one or more of the measurement sources required for IPI is not available. Check availability of etCO ₂ , awRR, SpO ₂ , and pulse rate.
IPI Neo Patient ?	Check patient category. The IPI numeric is not available for neonatal patients.

SO₂ INOPs

INOP Message, Indication	What to do
<SO₂ Label> Cal Failed Numeric is replaced by -?- INOP tone	The calibration failed. Check the catheter-to-Optical-Module connection. Manually restart the calibration. Try another catheter and Optical Module. If the catheter is already inserted, perform an in-vivo calibration.
<SO₂ Label>Cal Required Numeric is replaced by -?- INOP tone	There is no valid calibration data in the Optical Module. Perform either a pre-insertion or an in-vivo calibration.
<SO₂ Label> Cal. Mode Numeric is replaced by -?- INOP tone	Pre-insertion calibration is complete, but the catheter tip is still inside the optical reference. The catheter is now ready for insertion.
<SO₂ Label> Cannot Meas Numeric is replaced by -?- INOP tone	The signal is out of the normal range, and no oxygen saturation can be derived. Perform an in-vivo calibration. If the INOP persists, try another Optical Module and catheter.
<SO₂ Label>Config Error Numeric is replaced by -?- INOP tone	The Optical Module has been configured to SaO ₂ Mode. Use Change to Venous in the setup menu to reconfigure to venous saturation mode.
<SO₂ Label> Conn OptMod Numeric is replaced by -?- INOP tone	The Optical Module was disconnected during data storage. Reconnect the Optical Module for at least 20 seconds.
<SO₂ Label> Equip Malf Numeric is replaced by -?- INOP tone	The SO ₂ /SvO ₂ Module or Optical Module is faulty. Unplug and replug the Optical Module and SO ₂ /SvO ₂ module. Exchange the modules. If the INOP persists, contact your service personnel.
<SO₂ Label> Incompat. INOP tone	The SO ₂ Module or Optical Module is not supported. Contact your service personnel.
<SO₂ Label> In-Vivo Cal	The in-vivo calibration is not yet complete. Lab values must be stored to the Optical Module to complete the calibration. Either continue with the next steps of the current calibration or recall the previous calibration.

INOP Message, Indication	What to do
<SO₂ Label> Light Intens Numeric is replaced by -?- INOP tone	The intensity changed considerably since the last light intensity calibration. This may indicate that the catheter tip is positioned against a blood vessel wall or that there is low blood flow. Reposition the catheter (and perform a Light Intensity Calibration).
<SO₂ Label> Low Light Numeric is replaced by -?- INOP tone	The optical signal levels are too low. Check that the catheter is either in the optical reference or inserted into the patient. Check the catheter-to-Optical Module connection. If INOP persists, try another catheter and Optical Module.
<SO₂ Label> No OptMod Numeric is replaced by -?- INOP tone	Connect the Optical Module. If the INOP persists, try another Optical Module. Silencing this INOP switches the measurement off.
<SO₂ Label> OptMod Malf	The Optical Module memory is faulty, and calibration data cannot be stored for transport or during power failure. If this capability is needed, use another Optical Module.
<SO₂ Label> Pre-Ins Cal Numeric is replaced by -?- INOP tone	The pre-insertion calibration is running. This typically takes one minute. During this time alarms are switched off. Wait until the calibration is complete.
<SO₂ Label> Unplugged Numeric is replaced by -?- INOP tone	Measurement switched on and SO ₂ /SvO ₂ module unplugged from the rack.
<SO₂ Label> Upgrade INOP tone	The SO ₂ module is currently in upgrade mode. Monitoring is not possible in this mode.
<SO₂ Label> Warmup Numeric is replaced by -?-	The Optical Module has not yet reached the operating temperature. Wait a few minutes until warm-up is finished.

C.O. INOPs

INOP Message, Indication	What to do
C.O. Deactivated INOP tone	The Cardiac Output measurement label in the measurement device has been deactivated by deactivating the label in the Measurement Selection window. The measurement automatically disappears from the display. To switch the measurement on again, reactivate the measurement label in the Measurement Selection window.
C.O. Equip Malf Numeric is replaced by -?- INOP tone	There is a problem with the C.O. hardware. Contact your service personnel.
C.O. Unplugged Numeric is replaced by -?- INOP tone	Plug in the C.O. module. Silencing this INOP switches off the measurement.
CCI No BSA CCI numeric unavailable INOP tone	CCI cannot be calculated because the patient's body surface area is unknown. Enter the patient weight and height to provide the BSA for CCI calculation.
CCO BadPressSignal Numeric is replaced by -?- INOP tone	The arterial pressure wave can currently not be used for pulse contour calculation for CCO or CCI measurement. Possible causes are air bubbles in the tubing or a physiological condition, for example severe arrhythmia.
CCO No Calibration Numeric is replaced by -?-	The CCO measurement is currently not calibrated.
CCO No <Press Label> Numeric is replaced by -?- INOP tone may sound	CCO/CCI cannot be calculated. Make sure that the pressure chosen in the Setup CCO menu under CCO from matches the pressure measured with the arterial catheter for CCO measurement. A pressure from an external device cannot be used. Select another pressure label, either ABP, Ao, ART, BAP, FAP, or UAP.

4 Patient Alarms and INOPs

INOP Message, Indication	What to do
CCO No Press at Information Center	CCO/CCI cannot be calculated. Make sure that the pressure chosen in the Setup CCO menu under CCO from matches the pressure measured with the arterial catheter for CCO measurement. A pressure from an external device cannot be used. Select another pressure label, either ABP, Ao, ART, BAP, FAP, or UAP.
CCO Not Supported Numeric is replaced by -?- INOP tone	A catheter for transpulmonary C.O. measurements has been unplugged and replaced with a Right Heart C.O. catheter, or the measurement mode has been changed manually. Silencing this INOP switches the measurement off.
CCO Overage CCI Overage Numeric is replaced by -?- INOP tone	The measured CCO or CCI value is not within the specified range for CCO/CCI measurement.
CCO Press Invalid at Information Center	The arterial pressure selected for pulse contour calculation for CCO is available but currently invalid. Make sure the pressure transducer is connected and the zero calibration is valid.
CCO <Press Label> Invalid Numeric is replaced by -?- INOP tone may sound	The arterial pressure selected for pulse contour calculation for CCO is available but currently invalid. Make sure the pressure transducer is connected and the zero calibration is valid.
CCO PressOverrange Numeric is replaced by -?- INOP tone	The mean value of the arterial pressure values used for pulse contour calculation for CCO is below 0 mmHg or above 300 mmHg.
CCO PulseOverrange Numeric is replaced by -?- INOP tone	The pulse rate of the pressure used for pulse contour calculation for CCO is below 30 bpm or above 240 bpm.
CCO Recalibrate Numeric is replaced by -?-	The most recent CCO or CCI calibration was made over 8 hours ago or the arterial pressure measurement used for CCO calculation has been zeroed after the CCO calibration was performed. You should recalibrate CCO or CCI with transpulmonary C.O. measurements at least every 8 hours or when the hemodynamic condition of the patient has changed. The pressure measurement must be zeroed before a CCO calibration.
CCO/Tbl NoTransduc Numeric is replaced by -?- INOP tone	No transducer attached to the module or catheter disconnected.
Tblood Overage Numeric is replaced by -?-	Tblood out of range 17°C - 43°C.
TbloodNoTransducer Numeric is replaced by -?- INOP tone	No transducer attached to the module or catheter disconnected.

tcGas INOPs

INOP Message, Indication	What to do
<tcGas Label> Cal Failed Numeric is replaced by -?- INOP tone	A calibration failed. Check the calibration unit, gas pressure, and tubing connections, then restart the calibration. If the calibration has failed more than once, remembrane the transducer and restart the calibration. If this INOP persists, contact your service personnel.
<tcGas Label> Cal Running Numeric displays first -?-, then numeric is displayed with a ?	Wait until the tcpO ₂ /tcpCO ₂ calibration is finished.
<tcGas Label> CalRequired Numeric is replaced by -?- INOP tone	Calibration is required before applying the transducer to the patient. Insert a membraned transducer into the calibration chamber on the module, connect the calibration unit to the calibration chamber, open the gas valve and start the calibration. If this INOP occurs during a calibration, there may be a module or transducer malfunction: contact your service personnel.

INOP Message, Indication	What to do
<tcGas Label> Change Site If Heat Switch Off is configured to Yes , numeric is replaced by -?- INOP tone	Site Timer has timed out. Change the application site to avoid skin burns. To reset the Site Timer, either calibrate and change the measurement site, or change the measurement site and reset the Site Timer manually by selecting the appropriate site time from the Setup tcGas menu.
<tcGas Label> Check Time	Site Timer due to time out in 15 minutes or less.
<tcGas Label> Equip Malf Numeric is replaced by -?- INOP tone	There is a malfunction in the transducer or module. Connect another transducer. If this INOP persists, contact your service personnel.
<tcGas Label> NoTransducer Numeric is replaced by -?- INOP tone	No transducer is connected to the tcpO ₂ /tcpCO ₂ module. Silencing the alarm switches off the measurement.
<tcGas Label> Stabilizing A ? appears next to the label	The transducer has not yet reached the selected temperature and/or skin hyperemization is not yet finished. This INOP will disappear within three minutes.
<tcGas Label> Unplugged Numeric is replaced by -?- INOP tone	The measurement is switched on but the module is unplugged. The measurement automatically disappears from the display. Silencing this INOP switches off the measurement.

EEG INOPs

INOP Message, Indication	What to do
EEG Equip Malf INOP tone	The EEG hardware is faulty. Contact your service personnel.
EEG Impedance High EEG1 ImpedanceHigh EEG2 ImpedanceHigh	The signal electrode in one or both channels exceeds the user-selected impedance limit, or the impedance of a single electrode exceeds the limit. Check the impedance. If the impedance is too high, reconnect the electrodes according to the EEG monitoring setup guidelines. If the INOP persists, contact your service personnel.
EEG Line Noise EEG1 Line Noise EEG2 Line Noise	Excessive line noise has been detected in either channel EEG1 or EEG2, or in both EEG channels. Keep all cables together and away from metallic bodies, other cables & radiated fields.
EEG Muscle Noise EEG1 Muscle Noise EEG2 Muscle Noise	Too much power above 30 Hz has been detected in channel EEG1 or EEG2, or both. Check the Electrode-to-Skin Impedance and reposition the electrode away from possible muscle activity, if necessary.
EEG Unplugged INOP tone	Plug in module. Silencing this INOP switches off the measurement.
EEG1 Lead Off <n> EEG2 Lead Off <n> [n = electrode]	Reconnect specified electrode.
EEG1 Lead Off EEG2 Lead Off at Information Center	One or more electrodes are not connected. Check in the EEG Impedance / Montage window on the monitor which electrode(s) are affected and reconnect the electrodes.
EEG1 Leads Off EEG2 Leads Off	Two or more electrodes are not connected. Check in the EEG Impedance / Montage window which electrodes are affected and reconnect the electrodes.
EEG1 Overrange EEG2 Overrange	Input signal is too high in one or both channels. This is usually caused by interfering signals such as line noise or electro-surgery.
EEGNoTransducer INOP tone	The trunk cable is disconnected from the EEG plug-in module. Reconnect the trunk cable. Silencing this INOP switches the measurement off.

BIS INOPs

INOP Message, Indication	What to do
BIS Cable Incompat INOP tone	The semi-reusable sensor cable connected is unknown or not supported by your software revision. Replace it with a Philips-supported sensor cable.
BIS Cable Usage INOP tone	The semi-reusable sensor cable has exceeded the maximum number of uses. Replace the cable.
BIS DSC Disconnect INOP tone	DSC is not properly connected OR either DSC or BIS engine may be faulty. Make sure that the DSC is properly connected to the BIS Engine. If INOP persists, replace DSC with a known good one of the same type. If INOP persists replace BIS engine. Silencing this INOP switches the measurement off.
BIS DSC Incompat. INOP tone	DSC is not supported by the BIS engine or new DSC connected to an old BIS engine. A software upgrade may be required. Contact your service personnel.
BIS DSC Malfunct	Electrocautery used during self-test OR malfunction in the DSC hardware. Make sure not to use electrocautery during the self-test procedure. Disconnect and reconnect the DSC to the BIS engine. If the INOP persists, replace the DSC or contact your service personnel.
BIS DSC Upgrade INOP tone	DSC update currently being carried out. This INOP will disappear when the DSC update is finished. Do not disconnect the DSC during the update. No action is needed.
BIS Electr. Disc. INOP tone	One or more electrodes are not connected to the semi-reusable sensor cable. Check all electrode connections.
BIS Engine Disconn INOP tone	BIS engine not connected OR Module Cable defective. Make sure that the Module Cable is properly connected. If INOP persists, replace the Module Cable. Silencing this INOP switches the measurement off.
BIS Engine Incomp. INOP tone	BIS engine software is not supported. A software upgrade may be required. Contact your service personnel. MP20/30 - BIS engine not supported.
BIS Engine Malfunc INOP tone	Malfunction in the BIS engine hardware. Disconnect and reconnect the BIS engine. If the INOP persists, replace BIS engine.
BIS Equip Malf INOP tone	There is a malfunction in the BIS hardware. Unplug and replug the BIS module. If the INOP persists, contact your service personnel.
BIS High Impedance INOP tone may sound	Impedance of one or more electrode(s) is above the valid range, most often caused by bad skin preparation. Check the sensor montage and press the electrode pads firmly. If this INOP persists, replace the sensor(s) in question using correct skin preparation. If INOP persists, contact your service personnel.
BIS ImpedanceCheck INOP tone may sound	The Cyclic Impedance check is running. It will stop automatically if all impedances are within the valid range. If any electrodes do not pass the impedance test, check the sensor montage and press the electrode pads firmly. To manually stop the Cyclic Impedance Check, select Sensor Check off in the Setup BIS menu.
BIS IsoelectricEEG	No discernible EEG activity is detected for longer than one minute. Check the patient. Check that the electrodes are properly connected.
BIS Lead Off INOP tone may sound	One or more electrodes have no skin contact and therefore impedances cannot be measured. Check the sensor montage and press the electrode pads firmly. If this INOP persists, replace the sensor(s) in question, using correct skin preparation.
BIS Overcurrent INOP tone	Unplug and replug the BIS module or, f or the MP20/MP30, disconnect and reconnect the BISx from the Interface board. If the INOP persists, contact your service personnel.

INOP Message, Indication	What to do
BIS Sensor Disconn INOP tone	The sensor is not properly connected to the patient interface cable (PIC) and/or the PIC is not properly connected to the DSC or BISx, or the sensor or PIC or DSC or BISx may be faulty. Check all the connections. Disconnect and reconnect the sensor, PIC, DSC, BISx. If the INOP persists, replace the sensor. If the INOP persists, replace PIC. If INOP persists, contact your service personnel. Silencing this INOP switches the measurement off.
BIS Sensor Incomp. INOP tone	Unsupported sensor connected or sensor type unknown or not supported by your software revision. Replace the sensor, using only Philips supported sensors.
BIS Sensor Malfunc INOP tone	Malfunction in the sensor hardware, most often caused by liquids permeating into the connectors OR patient interface cable (PIC) or DSC or BISx may be faulty. Replace the sensor. Manually initiate a Cyclic Impedance Check. Make sure all electrodes pass the test. Make sure that the both sides of the PIC connector (between PIC and sensor) are dry. If you are not sure that the connector is dry, replace the PIC until it has dried. If this INOP persists, contact your service personnel.
BIS Sensor Usage INOP tone	Excessive sensor usage. Replace sensor. A Cyclic Impedance Check will start automatically.
BIS SQI < 15% INOP tone	If the signal quality is below 15%, no BIS numerics can be derived. This may occur as a result of artifacts such as those generated from motion or the presence of electrocautery devices. Make sure the sensor is properly attached to the patient. Manually initiate a Cyclic Impedance Check. Make sure all electrodes pass the test. Make sure the patient is completely relaxed (even small motions of the facial muscles affect the signal quality).
BIS Unplugged INOP tone	Plug in the BIS module. Silencing this INOP switches off the measurement.
BISx Disconnected INOP tone	The BISx is not connected to the BIS module or the BIS interface board. Silencing this INOP switches the measurement off.
BISx Incompatible INOP tone	The BISx software is not compatible with the BIS module or with the MP20/MP30 monitor software. A software upgrade may be required. Contact your service personnel.
BISx Malfunction INOP tone	The BISx is faulty. Disconnect and reconnect it to the module or BIS interface board. If the INOP persists, replace the BISx. MP20/MP30 - Malfunction on interface board. If the INOP persists, contact your service personnel.

Spirometry INOPs

INOP Message, Indication	What to do
AWFChange Scale	Airway flow signal exceeds range of selected scale. Adjust scale to display complete wave.
AWPChange Scale	Airway pressure signal exceeds range of selected scale. Adjust scale to display complete wave.
AWVChange Scale	Airway volume signal exceeds range of selected scale. Adjust scale to display complete wave.
Spiro Alarms Suppr	Alarming is suppressed for the spirometry module.
SPIRO Cannot Meas	Measurement is at its limit, e.g. ambient pressure out of range.
Spiro Gas Compens?	Gas compensation is set to Gas Analyzer but not all gases necessary for compensation are measured by a gas monitor. Some of the fall-back values provided by the user are used. Measurement accuracy might be reduced.
Spiro Incompatible	Module revision not compatible with the host monitor software revision. Contact your service personnel.
Spiro Malfunction	Module failure detected. Contact your service personnel.
Spiro No Breath	No breath was detected for more than 25 seconds. Breath derived numerics are not available.
Spiro No Sensor	No sensor detected. Make sure the correct sensor is attached to the breathing circuit.

4 Patient Alarms and INOPs

INOP Message, Indication	What to do
Spiro Patient Cat.	Mismatch of patient size configured in the host monitor and sensor type plugged into the module. Check the instructions on selecting the correct sensor in the chapter on “Spirometry”.
Spiro Purge Failed	The purge operation could not be completed successfully. Check for kinked sensor tubings, hard occlusions and make sure that the pump is running and all valves are switching.
Spiro Purging	A purge operation is in progress - no data update on the screen. Wait until purge is complete.
Spiro Unkn. Sensor	An unknown sensor ID code was detected. Use only the sensors listed in the “Accessories” chapter.
Spiro Upgrade	The module is running a firmware upgrade. Wait until upgrade is completed before resuming monitoring.

NMT INOPs

INOP Message, Indication	Explanation
NMT Alarm Suppress	NMT alarms are suppressed until the TOF count reaches zero for the first time.
NMT Cable Disconn INOP tone	No patient cable is connected to the NMT measurement module. Silencing this INOP switches the NMT measurement off.
NMT Cable Unknown INOP tone	The patient cable connected to the NMT module is not supported or cannot be identified. Replace it with a supported cable.
NMT Cal Failed	The NMT calibration cycle failed. Check that the sensor and the electrodes are placed properly, then start another calibration. Ensure that patient's arm is kept still before and during the calibration cycle. If calibration fails again, replace the patient cable. If INOP persists, contact your service personnel.
NMT Cal Running	An NMT calibration is running. Wait until the calibration is complete.
NMT Cannot Measure INOP tone	NMT is unable to reliably derive measurement values. Check that the sensor and the electrodes are placed properly and start another measurement. If this INOP persists, try another patient cable.
NMT Equip Malfunct INOP tone	There is a problem with the NMT hardware. Unplug the NMT measurement module then plug it in again. If the INOP persists contact your service personnel.
NMT Impedance High	The impedance of the NMT stimulation electrodes has exceeded the allowed limit. Check that the electrodes are placed properly, have firm skin contact and have not dried out.
NMT Incompatible INOP tone	This version of the NMT measurement module is not supported, or the module firmware is incomplete and needs to be upgraded. Contact your service personnel.
NMT Lead Off INOP tone	One or both NMT stimulation electrodes have become detached from the patient. Check that both electrodes have firm skin contact, that the electrodes are placed properly and that the lead wires are connected.
NMT Neo Patient? INOP tone	The NMT measurement does not support neonatal patients. Check the patient category.
NMT Noisy Signal INOP tone	The NMT signal is too noisy to derive measurement values reliably. If electrosurgery is currently being used, repeat the NMT measurement after it has stopped.
NMT Overcurrent INOP tone	The current through the NMT stimulation electrodes is too high. Check that the patient cable is not visibly damaged. Disconnect and reconnect the patient cable. If this INOP persists, replace the cable and/or module.
NMT Overrange	The signal from the acceleration sensor is out of the measurement range. Check that the acceleration sensor is positioned properly. If this INOP persists, try another patient cable.
NMT Sensor Malfunc INOP tone	There is a problem with the acceleration sensor of the NMT patient cable. Disconnect and reconnect the patient cable. If this INOP persists, replace the cable.
NMT Upgrade INOP tone	An NMT module firmware upgrade is in progress. NMT monitoring is currently not possible. Wait until the upgrade has completed and this INOP is no longer displayed. Do not unplug the module or switch off power.

VueLink INOPs

INOP Message, Indication	What to do
VueLink Alarm at Information Center	A technical alarm is present on the VueLink module. The INOP text on the monitor is defined by the VueLink device driver.
<VueLink Option> Check Cable INOP tone	No cable or the wrong cable connected to the VueLink module, or incorrect device selected. Silencing this INOP switches the measurement off. VueLink INOP abbreviations may differ slightly depending on the device category.
<VueLink Option> Check Setup INOP tone	No information was received from the external device. The device may be switched off or disconnected. VueLink INOP abbreviations may differ slightly depending on the device category.
<VueLink Option> Chk Config INOP tone	The wrong external device has been selected on the VueLink module, or the external device has not been correctly setup, or the wrong cable has been used to connect the device to the VueLink module. VueLink INOP abbreviations may differ slightly depending on the device category.
<VueLink Option> Equip Malf INOP tone	Malfunction in the VueLink module. If this message appears repeatedly, the module must be replaced. Contact your service personnel. VueLink INOP abbreviations may differ slightly depending on the device category.
<VueLink Option> No Config INOP tone	The VueLink module has not been configured during installation. The installation process should be completed by either your biomedical engineering department or the Philips service engineer. VueLink INOP abbreviations may differ slightly depending on the device category.
<VueLink Option> Unplugged INOP tone	The VueLink module has been unplugged from the rack, or the whole rack has been disconnected. The measurement automatically disappears from the display. Silencing this INOP switches off the measurement. VueLink INOP abbreviations may differ slightly depending on the device category.

IntelliBridge INOPs

INOP Message, Indication	What to do
Device Check Setup INOP tone	Device identification completed, but communication could not be established due to timeout. IntelliBridge INOP abbreviations may differ slightly depending on the device category.
Device Chk Config INOP tone	Device identification completed, but communication could not be established due to error. IntelliBridge INOP abbreviations may differ slightly depending on the device category.
Device Demo Data INOP tone	The device connected to the IntelliBridge module reports demo data but the monitor is not in DEMO mode.
Device Real Data INOP tone	The monitor is in DEMO mode but the device connected to the IntelliBridge module reports data that are not flagged as demo data.
Device Unsupported INOP tone	Device identification completed, but no appropriate device driver installed. IntelliBridge INOP abbreviations may differ slightly depending on the device category.
<EC10 / EC40> Equip Malf INOP tone	Malfunction in the IntelliBridge module. If this message appears repeatedly, the module must be replaced. Contact your service personnel.
EC10 INOP !! EC10 INOP !!! EC10 INOP at Information Center	A technical alarm is present on the IntelliBridge EC10 module. On the monitor the indication is a red (!!!), yellow (!!) or cyan alarm lamp (as appropriate), an INOP tone and an INOP text that is defined by the IntelliBridge EC10 device driver.
<External Device> Unplugged INOP tone	The IntelliBridge module has been unplugged from the rack, or the whole rack has been disconnected. Silencing this INOP switches off the measurement. IntelliBridge INOP abbreviations may differ slightly depending on the device category.
No Device Data	Communication with connected device has been lost.

4 Patient Alarms and INOPs

INOP Message, Indication	What to do
Text Upload Failed INOP tone	Incoming text from the IntelliBridge modules exceeds the maximum limit. Try unplugging one of the IntelliBridge modules. If the INOP occurs repeatedly contact your service personnel; a software upgrade may be necessary.

Telemetry INOPs

INOP Message, Indication	What to do
Check ECG Settings INOP tone	Synchronization of ECG settings between the monitor and Information Center has failed. Check that the ECG settings in use are appropriate.
!!Check ECG Source	Both the telemetry device and the monitor have valid ECG signals
Chk SpO₂T Settings INOP tone	Synchronization of SpO ₂ T settings between the monitor and Information Center has failed. Check that the SpO ₂ T settings in use are appropriate.
Invalid Leadset	The leadset plugged in cannot be used with the telemetry device.
Leadset Unplugged	The leadset has been unplugged from the telemetry device.
No ECG Source	A telemetry device is paired with the monitor but the Information Center is not detecting a valid ECG signal from either of them.
!! Repl. Tele Batt !!!Repl. Tele Batt Severe yellow/red INOP tone During this INOP, alarms cannot be paused or switched off.	The battery in the telemetry device is almost empty and must be replaced.
Tele Battery Low	The battery in the Telemetry device is low and must be replaced soon.
!!Tele Disconnect !!!Tele Disconnect Severe yellow/red INOP tone	Telemetry transceiver was disconnected or short range radio link was lost. For cable connections; check Telemetry interface, cable connection and setup. For short range radio connections: if the telemetry transceiver has not moved out-of-range, check for interference sources close to the monitor (bluetooth devices, DECT phones, cellular phones, microwaves, etc.). If this INOP persists, ask your service personnel to survey the interference sources.
!! Tele INOP !!! Tele INOP Severe yellow/red INOP tone	Check for further details at the Information Center or in the Telemetry Data window on the monitor.
Tele Sync Unsupp. INOP tone	The MMS in use does not support synchronization of ECG and SpO ₂ settings between the monitor and central station after a telemetry device has been paired. Use an MMS with revision E.0 or above.

ProtocolWatch INOPs

INOP Message, Indication	What to do
PW: Check Settings	Contact your service personnel. Settings could not be loaded or interpreted correctly.
PW: In Conflict	There is a patient information mismatch which has not yet been resolved (>15 minutes).
PW:Action Required	The protocol currently running requires a user response. Check which pop-up window is displayed and provide the appropriate response.

Calculated Values INOPs

INOP Message, Indication	What to do
ΔSpO₂ Chk Sources Numeric is replaced by -?-	Not all measurements or values required to perform the calculation are available. Check measurement sources.

INOP Message, Indication	What to do
ΔSpO₂ Chk Units Numeric is replaced by -?-	The monitor has detected a conflict in the units used for this calculation. Check the unit settings.
Sp-vO₂ Chk Sources Numeric is replaced by -?-	Not all measurements or values required to perform the calculation are available. Check measurement sources.
Sp-vO₂ Chk Units Numeric is replaced by -?-	The monitor has detected a conflict in the units used for this calculation. Check the unit settings.
SVR Chk Sources SVRI Chk Sources Numeric is replaced by -?-	Not all measurements or values required to perform the calculation are available. Check measurement sources.
SVR Chk Units SVRI Chk Units Numeric is replaced by -?-	The monitor has detected a conflict in the units used for this calculation. Check the unit settings.
SVRSet CVP Used SVRISet CVP Used	A CVP value is required for this calculation, but is not currently being measured. The monitor is using the CVP value preset in the Setup SVR menu.
ΔTemp Chk Sources Numeric is replaced by -?-	Not all measurements or values required to perform the calculation are available. Check measurement sources.
ΔTemp Chk Units Numeric is replaced by -?-	The monitor has detected a conflict in the units used for this calculation. Check the unit settings.

Cableless Measurement Device INOPs

INOP Message, Indication	What to do
cl NBP Batt Empty !!cl NBP BattEmpty !!!cl NBP BatEmpty Corresponding INOP tone	The remaining battery time of the NBP Pod is below 30 minutes. Charge the battery.
cl NBP Batt Incomp INOP tone	The battery in use with the NBP Pod is incompatible. Replace it with one approved for use with the NBP Pod.
cl NBP Batt Low INOP tone	The remaining battery time of the NBP Pod is below 2 hours.
cl NBP Batt Malf INOP tone	There is a malfunction in the NBP Pod's battery system. Contact your service personnel.
cl NBP Batt Temp INOP tone	The temperature of the battery in the NBP Pod is critically high. Check that the Pod is not covered or exposed to a heat source. If the INOP persists, remove the Pod from the patient and contact your service personnel.
cl NBP Check Batt INOP tone	The battery in the NBP Pod is nearing the end of its useful life. Only 50 charge/discharge cycles remain. Contact your service personnel to replace the battery.
cl NBP Chk Chrg IF	The interface between the NBP Pod and the Charging Station is not working properly. Try cleaning the contacts and reposition the Pod on the charging station.
cl NBP ChkSettings	The NBP Pod's settings may have changed or become corrupt. Check the settings.
cl NBP Disconnect INOP tone	The NBP Pod has lost the connection to the monitor.
cl NBP License Req	The NBP Pod requires a valid software license for operating.
cl NBP No Cradle INOP tone	The NBP Pod is not in its cradle.
cl NBP Remove INOP tone	The temperature of the battery in the NBP Pod is too high. Remove the Cableless Measurement Device from the patient and contact service personnel.

4 Patient Alarms and INOPs

INOP Message, Indication	What to do
cl NBP Serv Batt INOP tone	The battery in the NBP Pod has reached the end of its useful life. It can no longer be charged. Contact your service personnel to replace the battery.
cl SpO₂ Batt Empty !!cl SpO₂ BatEmpty !!!cl SpO₂ BtEmpty Corresponding INOP tone	The remaining battery time of the SpO ₂ Pod is below 30 minutes. Charge the battery.
cl SpO₂ Batt Incmp INOP tone	The battery in use with the SpO ₂ Pod is incompatible. Replace it with one approved for use with the SpO ₂ Pod.
cl SpO₂ Batt Low INOP tone	The remaining battery time of the SpO ₂ Pod is below 2 hours.
cl SpO₂ Batt Malf INOP tone	There is a malfunction in the SpO ₂ Pod's battery system. Contact your service personnel.
cl SpO₂ Batt Temp INOP tone	The temperature of the battery in the SpO ₂ Pod is critically high. Check that the Pod is not covered or exposed to a heat source. If the INOP persists, remove the Pod from the patient and contact your service personnel.
cl SpO₂ Check Batt INOP tone	The battery in the SpO ₂ Pod is nearing the end of its useful life. Only 50 charge/discharge cycles remain. Contact your service personnel to replace the battery.
cl SpO₂ Chk ChrgIF	The interface between the SpO ₂ Pod and the Charging Station is not working properly. Try cleaning the contacts and reposition the Pod on the charging station.
cl SpO₂ Chk Sett	The SpO ₂ Pod's settings may have changed or become corrupt. Check the settings.
cl SpO₂ Disconnect INOP tone	The SpO ₂ Pod has lost the connection to the monitor.
cl SpO₂ No Cradle INOP tone	The SpO ₂ Pod is not in its cradle.
cl SpO₂ Remove INOP tone	The temperature of the battery in the SpO ₂ Pod is too high. Remove the SpO ₂ Pod from the patient and contact service personnel.
cl SpO₂ Serv Batt INOP tone	The battery in the SpO ₂ Pod has reached the end of its useful life. It can no longer be charged. Contact your service personnel to replace the battery.
clSpO₂ License Req	The SpO ₂ Pod requires a valid software license for operating.

Managing Patients and Equipment

When the monitor is used together with an IntelliVue Information Center, a variety of services are provided to manage the interconnections between patients, equipment, hospital beds, caregivers, and so on.

Many services can be used both at the monitor and at the Information Center, resulting in a more efficient workflow.

Which services are available will depend on which Information Center you have. The **Philips IntelliVue Information Center iX (PIIC iX)** provides more services and functionality than the **Philips IntelliVue Information Center (PIIC)**. In these Instructions for Use, information that is only valid for one of the Information Centers will be marked with a corresponding side heading, for example

PIIC iX For a list of the differences between the two Information Centers, see “Information Center Compatibility” on page 132.

Patient Concepts

For a patient to be part of the system their identification data must be entered into the system. A patient can then be assigned to a bed, have equipment assigned directly to him, and have a location set when he is not currently in the bed.

Equipment Concepts

Depending on how equipment is used in your facility, there are various ways to associate devices with patients, beds or monitors. Equipment usage must be configured appropriately at the Information Center and the monitoring equipment.

PIIC iX By configuration, equipment can be assigned:

- permanently to a bed,
- on demand to a bed or host monitor, or
- directly to a patient.

The foundation for a particular equipment use model is laid in the configuration settings in the monitor and the Information Center. Refer to the corresponding configuration guides for further details.

Additionally there are mechanisms to automatically free up equipment that is no longer used. This prevents unnecessary patient mismatches when the equipment is used for the next patient and avoids data of different patients getting mixed.

PIIC iX When connected to PIIC iX, equipment states are tracked by the system. When the equipment is not assigned to a patient or no patient is admitted at a monitor, the equipment is considered as free equipment in the system. Equipment that is assigned or has a patient admitted is tracked as used (i.e. not free) equipment.

The Information Center uses the equipment state (free/not free) to maintain and support workflow and equipment lists.

Managing Patients

In order to attribute collected measurement data to a specific patient, or assign equipment or a bed to a specific patient, each patient in the system must be identified. By admitting a patient, you identify them for the system.

When equipment is freed up (for example by discharging the patient, removing a monitor from a patient or using End Case) the collection of data is officially ended for this patient and important settings on the monitor are reset to the defaults.

WARNING

Always perform a discharge or free up the monitor before starting monitoring for a new patient, even if your previous patient was not admitted. Failure to do so can lead to data being attributed to the wrong patient.

Admitting a Patient

The monitor displays physiological data and stores it in the trends as soon as a patient is connected. This lets you monitor a patient who is not yet admitted. It is however important to admit patients properly so that you can identify your patient on recordings, reports, and networked devices.

During admission you enter data that the monitor needs for safe and accurate operation. For example, the patient category setting determines the algorithm the monitor uses to process and calculate some measurements, the safety limits that apply for some measurements, and the alarm limit ranges.

NOTE

It is strongly recommended that the same patient data fields be configured to be mandatory at the monitor and the Information Center.

When No Patient is Admitted

To admit a patient:

- 1 Select the patient name field or select the **Patient Demogr.** SmartKey to open the **Patient Demographics** window.
- 2 Select **Admit Patient**.

The **Enter Patient Demographics** window appears. You can enter data as normal, using the keyboard or a barcode scanner, or, with **PIIC iX**, use the **Find Patient** key to search for patient data in connected systems as described in “Using "Find Patient" to Search for Patient Data” on page 107.

- 3 Enter the patient information: select each field and use the keyboard or barcode scanner or choose from the pop-up list of alternatives to input information.

PIIC iX

When you enter data, the Information Center will automatically check for corresponding data and will suggest an appropriate action based on what it finds. You can select **Confirm** to accept the suggestion or **Cancel** to reject it.

- **Last Name:** Enter the patient's last name (family name).
- **First Name:** Enter the patient's first name.
- **Middle Name** (if configured to appear): Enter the patient's middle name.
- **Lifetime ID, Encounter ID:** Whether these fields appear and how they are labeled can be configured for your hospital. One or both fields may be displayed and the labels may read: **MRN, Case ID, Visit Number**, or other alternatives. Enter the appropriate data for the fields displayed.
- **Patient Cat.:** Choose the patient category, either **Adult, Pedi,** or **Neo**.
- **Paced Mode:** Choose **On** or **Off** (You must use **On** if your patient has a pacemaker). With **PIIC iX** there is a third choice: **Unconfirmed**. When the paced mode is **Unconfirmed**, the algorithm for paced patients will be used.
- **Height:** Enter the patient's height.
- **Weight:** Enter the patient's weight.
- **BSA:** The monitor calculates the body surface area automatically.
- **Date of Birth:** Enter the patient's date of birth, in the form dd/mm/yyyy.
- **Age:** The monitor calculates the patient age automatically.
- **Gender:** Choose **Male** or **Female**.
- **Notes (1) / Notes (2):** Enter any extra information about the patient or treatment.

When admission is complete, the patient's name appears on the monitor info line at the top of the screen.

When a Patient is Already Admitted

If the patient monitor already has a patient admitted, the **Admit Patient** key is replaced by the **New Patient** key.

When you select **New Patient**, the monitor is freed. All settings are reset to the defaults, all patient data and trend data are deleted, and monitoring at the Information Center may stop for monitors designated as transport monitors. Depending on your equipment configuration, selecting **New Patient** may transfer the currently admitted patient out of the bed. A message will appear requiring your confirmation of these actions.

After selecting **New Patient**, you can admit your patient as described in “When No Patient is Admitted” above.

Using "Find Patient" to Search for Patient Data

- PIIC iX** You can use the **Find Patient** key to search for patient data in the Information Center and any connected hospital information systems. The search will look for currently admitted or previously admitted patients matching the search data you enter.

To search for patient data:

- 1 Select the **Find Patient** key.
A window opens with an on-screen keyboard.
- 2 Type in the last name or an ID, or a part of it, and select **Enter** on the keyboard.
The search results will be displayed in a **Select Patient** window. The system provides a list of all matching patients.
- 3 Highlight the patient you want to admit to this bed.
- 4 Depending on their current status, you will be asked whether you want to readmit them, or transfer them to this bed.
- 5 Select **Confirm** to complete the admission or transfer.

Patient Category and Paced Mode

The patient category setting determines the algorithm the monitor uses to process and calculate some measurements, the safety limits that apply for some measurements, and the alarm limit ranges.

The paced mode setting determines whether the monitor shows pacemaker pulses or not. When **Paced Mode** is set to **Off**, pace pulses are filtered and therefore do not show in the ECG wave.

WARNING

Patient Cat. and **Paced Mode** will always contain a value, regardless of whether the patient is fully admitted or not. If you do not specify settings for these fields, the monitor uses the default settings from the current profile, which might not be correct for your patient.

Patient category

Changing the patient category may change the arrhythmia and NBP alarm limits. If possible, always load a suitable profile after changing patient category, and always check alarm limits to make sure that they are appropriate for your patient.

Paced mode

For paced patients, you must set **Paced Mode** to **On**. If it is incorrectly set to **Off**, the monitor could mistake a pace pulse for a QRS and fail to alarm during asystole. With PIIC iX, the paced mode may be **Unconfirmed** which will assume a pacemaker is present. You should still set the **Paced Mode** to **On** for paced patients to make the status clear.

Admitting a Centrally-Monitored Patient

You can admit a patient at either the bedside or the Information Center. When you admit a patient, the patient's name appears on the bedside monitor and the Information Center.

If you do not fill in all patient information required by the Information Center, the Information Center may reject the admission. Complete all the required fields and try again to admit the patient.

Quick Admitting a Patient

Use Quick Admit to quickly admit a patient using only a limited set of demographic data.

- 1 Select the **Quick Admit** SmartKey.
- 2 Enter the required data (ID fields or last name depending on configuration) with the keyboard or a barcode scanner.

- 3 Select **Enter**.
- 4 In the confirmation window, select **Confirm** to stop monitoring for the previous patient or free up the monitor (if confirmation is configured).
- 5 Check that patient category and paced status are correct for the new patient.
- 6 Check the current profile and, if necessary, load an appropriate profile.

If the monitor is connected to an Information Center and only the ID field is entered, the patient name may be set to - - - at the Information Center, depending on the configuration. Complete the rest of the demographic details as soon as possible to fully identify the patient on the network, on the monitor and on printed reports. To complete the details, open the **Patient Demographics** window and complete all required fields.

Editing Patient Information

To edit the patient information after a patient has been admitted, select the patient name field on the Main Screen to open the **Patient Demographics** window, and make the required changes.

PIIC ix If data has been provided by a hospital information system, you will not be able to edit it on the monitor.

Ending Monitoring for a Patient

There are several ways to end monitoring for a patient, depending on whether there is an Information Center connection, and on the configuration of the Information Center and the monitor. Discharging a patient and removing the monitor from a patient are described here. You can also end monitoring by admitting a new patient, as described in “When a Patient is Already Admitted” on page 107.

Depending on your configuration, monitoring for a patient may end automatically when the monitor has been powered off or in standby mode for a set time, or when no basic measurements have been made for a set time.

WARNING

Always end monitoring for the previous patient (with **Discharge Patient, Remove Monitor, End Case** or **New Patient**) before starting monitoring for a new patient, even if your previous patient was not admitted. Failure to do so can lead to data being attributed to the wrong patient.

Discharging a Patient

The discharge function is only available when the patient is monitored centrally at an Information Center. A discharge transfers the patient out of the bed and frees all devices used for the patient. The discharge function may be disabled at a monitor designated as a transport monitor, to ensure that a patient cannot be accidentally discharged from the system when the transport monitor is used for another patient.

A discharge:

- clears the patient demographics
- erases all patient measurement data (such as trend, event, and calculation data) from the monitor, measurement modules and Information Center. This ensures that data from a previous patient are not mixed with data from a new patient.
- resets patient category and paced settings to the settings defined in the default Profile

- resets all monitor and measurement settings as well as the active Screen to the settings defined in the default Profile
- discharges the patient from the Information Center.

Make sure that you have printed out any required reports before discharging. Check that a functioning local or central printer is available before you use **End Case**.

To Discharge a Patient

- 1 Select the patient name field or select the **Patient Demogr.** SmartKey to open the **Patient Demographics** window and associated pop-up keys.
- 2 Select the pop-up key for either:
 - **End Case** - to print any configured end case reports or vital signs recording, discharge the patient and clear the patient database, then enter standby mode. If an **End Case** SmartKey is configured for your monitor, you can also select this instead and then confirm.

To see which end case reports are set up for your monitor, select **Main Setup, Reports**, then **Auto Reports**. For each auto report, if **End Case Report** is set to **On**, this report will be printed when you select **End Case**. See “Setting Up Auto Reports” on page 372 for information on setting up end case reports.
 - **Dischrge Patient** - to discharge the patient without printing any reports.

Removing the Monitor

Removing a monitor stops using the monitor for the current patient and frees up the monitor and all devices assigned to that monitor.

Removing the monitor:

- clears the patient demographics in the monitor.
- erases all patient measurement data (such as trend, event, and calculation data) from the monitor and devices assigned to the monitor. This ensures that data from a previous patient are not mixed with data from a new patient.
- resets patient category and paced settings to the settings defined in the default Profile.
- resets all monitor and measurement settings as well as the active Screen to the settings defined in the default Profile.

If the monitor is locked to the bed and is connected to an Information Center, the remove function is not available and you will have to discharge the patient.

To Remove a Monitor

- 1 Open the **Equipment** window - either directly in **Main Setup** or by selecting the bed label in the information line.
- 2 Select the monitor.
- 3 Select the **Remove Monitor** pop-up key.

New Patient Check

The monitor can be configured to ask you whether a new patient is now being monitored in certain situations:

- after a specified power-off period
- after a specified standby period

- when no basic vitals (HR, RR, Pulse, SpO₂, NBP) have been measured for a specified period

The pop-up window is entitled **Is this a New Patient?**. The monitor offers a **Yes** key to stop monitoring for the previous patient and begin monitoring a new patient and a **No** key to continue monitoring with the current patient data and settings.

The time periods for the three conditions can be configured independently.

Transferring Patients

To save you from having to enter the same patient data multiple times and enable patient transfer without loss of data, information can be shared between Multi-Measurement Modules (MMS), patient monitors, and Information Centers.

- patient demographic information is shared between connected MMSs, patient monitors, and Information Centers
- measurement settings and calibration data can be uploaded from an MMS to a patient monitor, if configured
- trend information can be uploaded from an MMS to a patient monitor, if configured.

Different sets of patient and measurement-related data are stored in the monitor and the Multi-Measurement Module. Understanding this will help you to understand what happens to patient data when you transfer patients.

Patient Information	Stored in Monitor	Stored in X1 MMS and extensions	Stored in X2 MMS and extensions
Patient demographics (name, DOB, patient IDs)	yes	yes	yes
Monitor settings (alarm pause time, alarm volume)	yes	no	no
Measurement settings for all measurements (alarm limits, measurement on/off, etc.)	yes	yes, for all MMS and MMS extension measurements	yes, for all MMS and MMS extension measurements
Trend data	yes, for all MMS, MMS extension and measurement module measurements (up to a maximum of 24 or 32 or 50 or 100, depending on your database configuration)	yes, most recent 8 hours of information, for all MMS and extensions measurements	yes, most recent 8 hours of information. A standalone X2 stores all MMS and MMS extension measurements (up to a maximum of 50 measurements). During Companion Mode the X2 stores all MMS and MMS extension measurements and measurements collected by the host monitor from measurement modules (up to a maximum of 50 measurements)

Patient Information	Stored in Monitor	Stored in X1 MMS and extensions	Stored in X2 MMS and extensions
Calculation data (HemoCalc data)	yes	no	no
Events data	yes	no	no

WARNING

If the monitor is not battery-powered, you cannot monitor during transport.

Measurements from an MMS extension connected to an X2 are not available when the X2 is running on its own battery power. They are only available when the X2 is powered by external power: when connected to a host monitor, to the external power supply (M8023A) or to the Battery Extension (865297).

The following sections describe the transfer procedures with a PIIC iX, a PIIC or with a standalone monitor.

Data Exchange Between Information Centers

You can transfer demographic data and trend data from one IIC to another by selecting **Transfer** on the patient monitor. Trend data is not shared between Information Centers and monitors.

Transferring Patients with IntelliVue Information Center iX

PIIC iX There are several ways to transfer a patient from or to another bed. When a patient is transferred to the destination bed, Information Center monitoring continues in the destination bed and equipment that is not transferred with the patient is freed up.

Using the Transfer Function

PIIC iX To transfer a patient using the transfer function provided on the patient monitor by the Information Center:

- 1 Select the patient name or the **Not Admitted** text at the top of the monitor screen to open the **Patient Demographics** window.
- 2 Select the **Transfer** pop-up key.
The **Transfer** window opens. If a patient is currently admitted, the window offers the possibility to transfer that patient to another bed (**To Other Bed**). If no patient is currently admitted, the window offers the possibility to transfer a patient **from** another bed using the patient search as described in “Using “Find Patient” to Search for Patient Data” on page 107.
- 3 With **To Other Bed**, if more than one unit is configured, a list of units will appear. When you have selected a unit, or if only one unit is configured, a list of free beds will appear.
- 4 Select a bed from the list.
You will be asked to confirm the transfer of the patient to this bed.
- 5 Select **Confirm** to complete the transfer.

If the system is configured to support transfer with equipment, the next step is that you move the patient together with the equipment, e.g. multi-measurement module, to the destination bed you have selected. If the equipment is still connected to the source bed, the **Transfer with Equipment** window opens requesting you to move the patient and equipment, but also offering the possibility to keep the multi-measurement module at the current bed for use with the next patient (with the pop-up key **No Unplug**).

WARNING

Before doing a transfer ensure that no other patient is using the destination bed and/or equipment from the destination bed.

When a patient is transferred you need to check that the patient has all the required monitoring equipment at the destination bed.

Moving the Patient with an MMS

- PIIC iX**
- 1 Connect the Multi-measurement Module to the patient monitor at the destination bed. A **Question** window will open, asking whether you want to transfer the patient to this bed.
 - 2 Select the **Yes** pop-up key to complete the transfer.

Using the New Patient Key

- PIIC iX** If the monitor at the destination bed is not free:
- 1 Select the patient name field at the top of the monitor to open the **Patient Demographics** window.
 - 2 Select **New Patient** to free up the monitor.
 - 3 Select **Find Patient** and enter your patient's name to get the patient data from the system. When you select your patient from the list, you will be asked to confirm that the patient should be transferred into this bed. After confirmation the transfer is complete.

Transferring Patients with IntelliVue Information Center

Transferring a Centrally-Monitored Patient

- PIIC** Scenario: A centrally-monitored patient is moved to another monitoring location on the same Information Center database server without interrupting the collection of patient trend information.
- 1 Before you disconnect the MMS from the monitor, select the patient name field or select the **Patient Demogr.** SmartKey to open the **Patient Demographics** window, then select the **Transfer** pop-up key. If the patient is not admitted or not monitored by an Information Center, the **Transfer** key is inactive ("grayed-out"). This step preserves the patient's demographic data during the transfer.
 - 2 Remove the MMS and any connected extensions from the monitor.
 - 3 Silence the resulting **MMS Unplugged** INOP.
 - 4 Connect the MMS to the transport monitor and monitor your patient during the move.

- 5 At the new location, connect the MMS to the monitor. If the monitor detects a patient mismatch, a window will open showing your patient's data and asking whether to **Complete transfer of this patient?**
- 6 Select **Yes** to complete the transfer. This re-admits the patient from the transfer list to the new monitor. This will upload the patient demographics, and, if configured, the measurement settings and trend data stored in the MMS to the receiving monitor.
- 7 Verify that the settings for patient category and paced mode are correct.

WARNING

Measurements from an MMS extension connected to an X2 are not available when the X2 is running on its own battery power. They are only available when the X2 is powered by external power: when connected to a host monitor, to the external power supply (M8023A) or to the Battery Extension (865297).

Transferring a Centrally-Monitored Patient with X2

PIIC Scenario: A centrally-monitored patient is moved to another monitoring location on the same Information Center database server without interrupting the collection of patient trend information.

- 1 Before you disconnect the X2 from the host monitor, select the patient name field or select the **Patient Demogr.** SmartKey to open the **Patient Demographics** window, then select the **Transfer** pop-up key. If the patient is not admitted or not monitored by an Information Center, the **Transfer** key is inactive ("grayed-out").
This step preserves the patient's demographic data during the transfer.
- 2 Remove the X2 and any connected extensions from the monitor.
- 3 Silence the resulting **MMS Unplugged INOP**.
- 4 Move the patient using the X2 as the transport monitor.
- 5 At the new location, connect the X2 to the new host monitor. If the monitor detects a patient mismatch, a window will open showing your patient's data and asking **Complete transfer of this patient?**
- 6 Select **Yes** to complete the transfer. This re-admits the patient from the transfer list to the new monitor. This will upload the patient demographics, and, if configured, the measurement settings and trend data stored in the X2 to the receiving monitor.
- 7 Verify that the settings for patient category and paced mode are correct.

Transferring a Centrally-Monitored Patient with X2 using IIT

PIIC Scenario: A centrally-monitored patient is moved with an X2 to another monitoring location on the same Information Center database server without interrupting the collection of patient trend information. The X2 has an IntelliVue Instrument Telemetry interface (IIT), is connected to a host monitor, and is declared as a telemetry device at the Information Center.

NOTE

The **Transfer** key is **not** available while the X2 is connected to a host monitor (**Companion Mode** is indicated).

- 1 Remove the X2 and any connected extensions from the host monitor.

- 2 Move the patient using the X2 as the transport monitor.
- 3 At the new location, **just before** connecting the X2 to the new host monitor:
 - open the **Patient Demographics** window.
 - select the **Transfer** pop-up key.
 - **wait** until the transfer has completed.
- 4 Connect the X2 to the new host monitor. The monitor detects a patient mismatch and a window will open showing your patient's data and asking **Complete transfer of this patient?**
- 5 Select **Yes** to complete the transfer. This re-admits the patient from the transfer list to the new monitor. This will upload the patient demographics, and, if configured, the measurement settings and trend data stored in the X2 to the receiving monitor.
- 6 Verify that the settings for patient category and paced mode are correct.

If you accidentally transfer a patient, use **Re-Admit** to restore this patient's data to the Information Center. If you are not connected to the network, select **Clear Transfer** to leave transfer mode. The patient data remains in the monitor.

Transferring Patients with Standalone Monitors (No Information Center)

Transferring a Patient with an X1

Scenario: A patient is moved to another monitoring location using a transport monitor and re-admitted at the new monitor.

- 1 Disconnect the X1 from the original monitor and silence the resulting **Unplugged INOP**.
If you are sure that the patient will not be returning to this monitor, you should perform a discharge or end-case. This prevents data from the next patient accidentally being mixed up with your current patient's data.
- 2 Connect the X1 to the transport monitor and move the patient.
- 3 At the new monitoring location, remove the X1 from the transport monitor and connect it to the new monitor.
- 4 If prompted, re-admit the patient to the new monitor: in the **Select Patient** window, select the patient in the X1 to retain the data in the X1. This will upload the patient demographics, and, if configured, the measurement settings and trend data stored in the X1 to the monitor. Verify that the settings for patient category and paced mode are correct.

Transferring a Patient with an X2

Scenario: A patient is moved to another monitoring location using the X2 and re-admitted at the new monitor.

- 1 Disconnect the X2 from the original host monitor and silence the resulting **Unplugged INOP**.
If you are sure that the patient will not be returning to this monitor, you should perform a discharge or end-case. This prevents data from the next patient accidentally being mixed up with your current patient's data.
- 2 Move the patient using the X2 as the transport monitor.
- 3 At the new monitoring location, connect the X2 to the new host monitor.

- 4 If prompted, re-admit the patient to the new monitor: in the **Select Patient** window of the new monitor, select the patient in the X2 to retain the data in the X2. This will upload the patient demographics, and, if configured, the measurement settings and trend data stored in the X2 to the monitor. Verify that the settings for patient category and paced mode are correct.

Data Upload from an MMS

The Multi-Measurement Module stores eight hours of patient trend data at one-minute resolution. It also stores patient demographic information and the measurement settings and calibration data for the measurements carried out by the MMS and any connected extensions. This data can be uploaded to an IntelliVue patient monitor, if your monitor is configured to do so and if at least five minutes of trend information is stored in the MMS.

Your monitor's data upload settings are defined in Configuration Mode to suit your patient transfer use model.

How data is uploaded to the host monitor depends on the configuration mode settings **Trend Upload** and **Settings Upload**.

If there is a patient mismatch and you select **Continue Monitor**, no data will be uploaded from the MMS.

Resolving Patient Information Mismatch

When you connect together devices which store patient demographic data, for example:

- an MMS and a monitor,
- an X2 and a host monitor,
- a monitor and an Information Center,

the system compares patient category, paced status, and unique patient identification in order to synchronize this information. If configured to do so, the monitor indicates a mismatch if the information is not identical.

Depending on your monitor's configuration, this mismatch may be automatically resolved or you may have to resolve it manually. If your monitor is configured to resolve mismatches automatically, depending on the configuration, either the monitor or the Multi-Measurement Module data is automatically retained.

WARNING

- It is important to resolve the mismatches as soon as they are identified. Failure to do so could result in using incorrect/confusing data to make clinical decisions. Certain settings, for example **Paced Mode** and **Patient Cat.**, may not match between the Information Center and the monitor. If the **Paced Mode** is set incorrectly, the system could mistake a pace pulse for a QRS and fail to alarm in the case of asystole. It is important that the patient category is set correctly so the ECG can be analyzed correctly and initial arrhythmia alarm limits set. A **Check Patient ID INOP** will appear when a mismatch has not been resolved.
- As long as patient mismatch has not been resolved, data integration in the Information Center and the own patient overview functionality might not work as equipment is not assigned correctly to the patient.

- PIIC** • When a monitor is connected to an Information Center by the wireless IntelliVue Instrument Telemetry interface, the patient data will automatically be merged in the case of a transfer. This means there is no patient discharge at the monitor and settings and trend data will be retained. You will see a message on the monitor and the **Patient Demographics** window will automatically appear so that you can check the data and change it if necessary.

In the case where an X2 with an *IntelliVue Instrument Telemetry interface* is declared as a "telemetry device" at the Information Center and is connected to a host monitor, it is important to resolve an existing mismatch between the monitor and the Information Center before disconnecting the X2. Failure to do so discharges the X2 and synchronizes the demographics and settings to the Information Center.

Manually Resolving Patient Mismatch

The patient mismatch is indicated by question marks (???) beside the questionable fields in the Monitor Info Line and in the **Select Patient** window. The monitor displays a message such as **Different patients in Central and Monitor**.

The **Select Patient** window automatically opens so you can decide which patient data to use. You do not have to resolve the mismatch immediately, but the indicators remain until you do. After 5 minutes a **Check Patient ID INOP** will appear to remind you to resolve the mismatch.

For some common mismatch situations, the monitor will simplify the resolution by suggesting a solution for the mismatch. For example, when a patient arrives after transport and the **Transfer** key has been selected, the monitor will show this patient's data and ask **Complete transfer of this patient?** You can then select **Yes** to complete the transfer. If you select **No** you will go to the **Select Patient** window.

There can be up to three sets of demographic data in the **Select Patient** window if the patient is different in the Information Center, monitor, and MMS.

After you resolve the mismatch, the monitor displays a confirmation window that shows the patient that has been selected and where data will be erased, if applicable. Confirm your choice. The monitor automatically displays the **Patient Demographics** window after confirmation. Verify that the settings shown are correct for the patient.

Gender, date of birth, height, weight, and nursing notes do not generate a mismatch. If these fields are different on different devices, the monitor resolves them itself. For example, it may take date of birth from the Information Center, whilst taking gender from the MMS. Always check the Patient Demographics after combining patients, to ensure that you are satisfied with the results. Change them if necessary.

WARNING

After resolving a patient mismatch, check that the monitor settings (especially patient category, paced status and alarm limits) are correct for the patient.

Patient Mismatch - If One Set of Patient Data is Correct

If there is a mismatch between an Information Center and a monitor, or a monitor and an MMS, choose the data set you want to continue using for this patient by selecting one of the sectors in the **Select Patient** window.

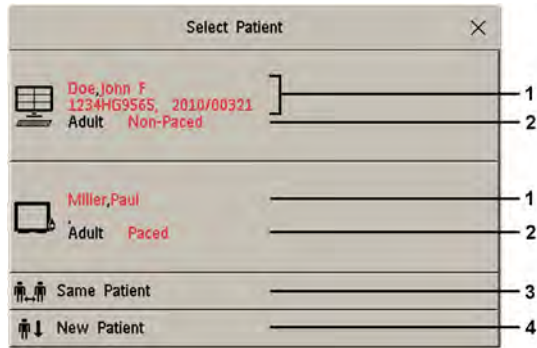

- 1 Patient demographics
- 2 Patient category and paced status
- 3 **Same Patient** - see “Patient Mismatch - If Both Patient Data Sets Refer to the Same Patient” on page 118.
- 4 **New Patient** - see “Patient Mismatch - If Neither Patient Data Set is Correct” on page 118.

After you resolve the mismatch, the monitor displays a confirmation window that shows the patient that has been selected and where data will be erased, if applicable. Confirm your choice. The monitor automatically displays the **Patient Demographics** window after confirmation. Verify that the settings shown are correct for the patient.

Patient Mismatch - If Neither Patient Data Set is Correct

A patient mismatch where neither set of patient data is correct might occur if you connect a new MMS to a monitor in order to prepare for a new patient, before you actually start measuring.

Select **New Patient** if you are sure that none of the information is correct. This uses the bed, monitor and MMS for a new patient, erases all data in both the monitor and MMS, resets all settings to the default Profile, and lets you admit a new patient.

Patient Mismatch - If Both Patient Data Sets Refer to the Same Patient

A patient mismatch where both sets of patient data are correct might occur if you admit a new patient at the monitor (or Information Center) before the patient arrives at your unit and then connect the MMS that was used during the patient transport to the monitor.

Select **Same Patient** if the patient information is different, but you are sure it is the same patient. This merges the demographics and updates them in the Information Center, monitor, and MMS, according to this table. Be aware that your monitor may be configured to merge trend data from the MMS and the monitor, and to upload measurement settings from the MMS to the monitor.

Patient Information	This information is taken from...
Patient name	the monitor, if the patient was admitted there. For centrally-admitted patients, this information is taken from the Information Center.
Patient IDs	
Screen Notes	

Patient Information	This information is taken from...
Patient Category	the Multi-Measurement Module, if connected, otherwise the data is taken from the monitor.
Date of Birth	
Height	
Weight	
Gender	
Paced Mode	Paced mode is always set to On where there is a mismatch in patient information.
Trend data	if there is newer trend data stored in the MMS, it is uploaded to the monitor.

Automatically Resolving Patient Mismatch

Your monitor can be configured to automatically resolve mismatches in one of two ways.

- continue using the patient in the MMS, and delete the old data in the monitor. This is suitable for transport monitors.
- continue with the patient in the monitor, and delete the data in the MMS.

When automatic mismatch resolution is configured, you may still be asked to confirm the resulting action at the monitor, depending on the current patient admission status.

Managing Equipment

Multiple pieces of monitoring equipment can be used for a patient. The association between a patient and a device can be made by:

- identifying the patient at the device (by entering patient data or using **Find Patient** to get patient data)
- "adding" equipment for an existing patient

The association between a patient and a device can be ended by:

- discharging the patient, or selecting **End Case**.
- "removing" the device from the patient.
- transferring the patient without the device.
- admitting a new patient to the device.
- automatic freeing of the device.

WARNING

In all cases listed above, when equipment is freed, all patient identification and measurement data are deleted, all settings are reset to the defaults, and monitoring at the Information Center (if active) is stopped. Any associated devices, e.g. multi measurement modules connected to a monitor, or cableless measurement devices assigned to a monitor, may also be freed, depending on the configuration.

Adding Equipment (PIIC iX)

By selecting the **Add Equipm.** key you can display a list of all free equipment (not currently assigned to a patient) and select a device for use with this patient. If you add another monitor, you need to confirm this at the selected monitor.

Removing Equipment

The association between a monitor and the patient can be ended by selecting **Remove Monitor**. With PIIC iX, the **Remove Monitor** key is not available when the monitor is locked to a bed.

Other equipment such as telemetry devices or IntelliVue Cableless Measurements can be removed by selecting the device then selecting **Remove** in the menu displayed.



Equipment Status Disputes

Equipment can come into situations where its status does not match its location. There are three typical situations where this may occur:

- PIIC iX only - equipment is locked to a bed, but has been removed and used at another bed.
- PIIC iX only - equipment has been configured for use in a specific unit, but is now being used in a different unit.
- Equipment has an equipment label but has not been configured at the Information Center and therefore cannot be managed.

If a monitor or a companion device is in one of these situations, a **Check Equipment INOP** will appear and the equipment status will be shown in the **Equipment** window.

The following symbols (in red) are used to show the status in the **Equipment** window:

	equipment is locked to another bed
	equipment is not configured for use in this unit
	equipment label is not in system configuration, or duplicate equipment labels

Using the Equipment Window

In the **Equipment** window you have access to patient management, workflow functions (set location, transfer), equipment management functions (add/remove equipment) and caregiver-related functions.

You can open the **Equipment** window directly in **Main Setup** or by selecting the bed label in the information line.

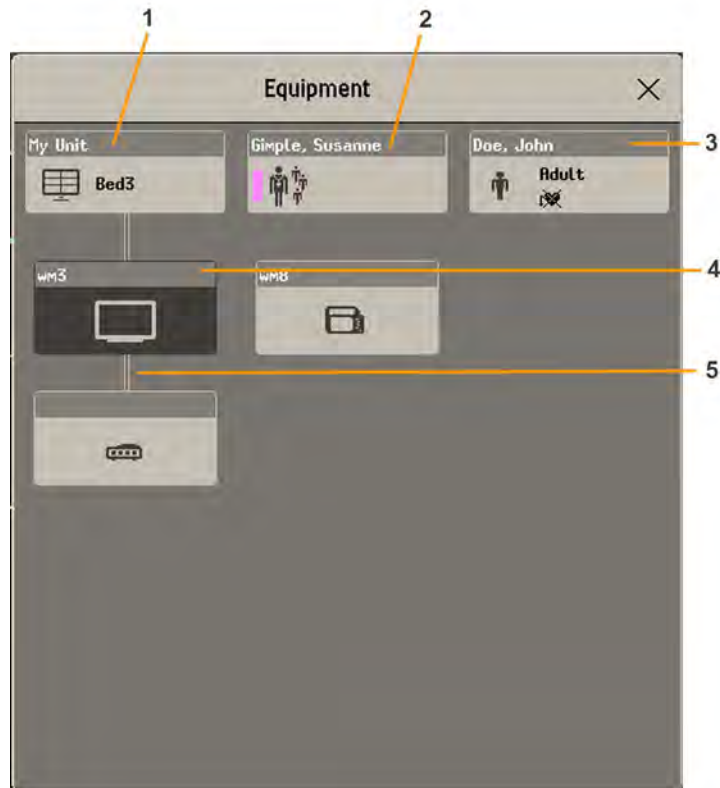

- 1 This bed is Bed 3, the connection to the Information Center is active.
- 2 Name of assigned caregiver
- 3 Patient name, category and paced mode
- 4 This monitor is assigned to the patient and is the one on which you are viewing the window.
- 5 Wired connection

The top part of the window contains the patient data, with the assigned caregiver and the status of the connection to the Information Center, and the bed label. In the lower part of the window, all equipment for this patient is shown, with the corresponding assignments and connections.

The device you are currently viewing the window on is shown with a dark background (in the above example, the monitor with the label wm3).

Changing Caregiver Assignment

When a caregiver is assigned, the caregiver name appears next to the caregiver symbol in the **Equipment** window. When you select this area of the window, a menu opens offering the following functions:

- PIIC iX • **Select Caregiver** - you can select a different caregiver from a list. When a new caregiver is assigned, the patient will be automatically added to that caregiver's Care Group. The availability of the function and the caregiver list depends on the Information Center configuration.
- **My Patients** - opens the **My Patients** window showing all patients in your Care Group.

Using the Patient Area

The patient name, patient category and paced status are normally shown in the **Equipment** window. When a patient has been prepared for transfer, the transfer symbol will be shown:



When you select this area in the **Equipment** window, a menu opens giving access to the **Enter Patient Demographics** window, the **Transfer** function (see “Transferring Patients” on page 111) and the **End Case** function.

Changing the Location

If the monitor is currently assigned to a bed, but the patient is in another department for treatment or a diagnostic procedure, you can show a temporary location for the patient.

- 1 Select the Information Center area on the **Equipment** window.
- 2 Select the current location from the list.

Or alternatively use the **Select Location** pop-up key.

The temporary location is then shown in the **Equipment** window, on the Standby screen on the monitor, and in the sector at the Information Center. When the patient returns, you can set the location back to the bed number in the same way as described above.

When Multiple Equipment is Used for One Patient

It is possible to assign additional monitoring equipment and a telemetry device to the same patient, resulting in the information from multiple devices being combined in one sector at the Information Center. The measurement data from the other devices will be displayed on the monitor screen in the own patient overview window.

WARNING

When new equipment has been added for a patient, you will be asked to confirm that the device be used for the patient. Always do this as soon as possible to avoid patient data mismatch.

If multiple equipment is assigned to the patient, resolving a patient mismatch at the monitor may resolve other pending patient mismatches or remove other associated equipment.

Own Patient Overview Window

The measurements from other monitoring devices and telemetry devices are shown combined in the own patient overview window on the monitor, together with related information derived by the Information Center, such as alarms.

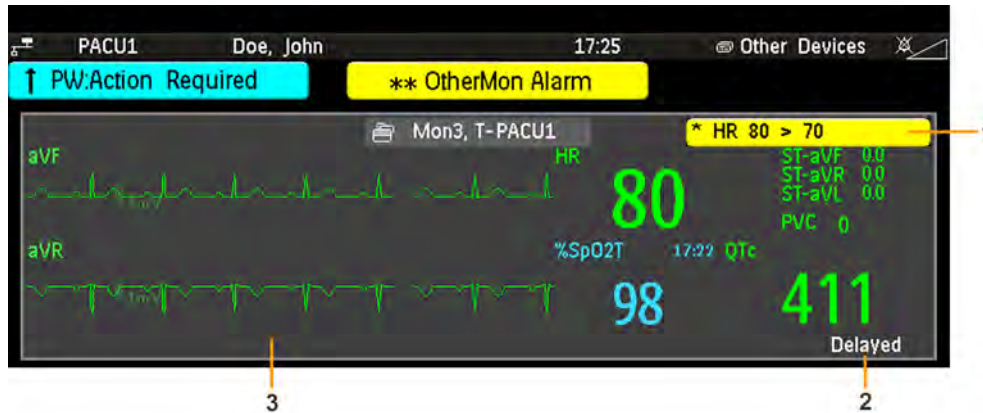



- 1 A current alarm generated by another device.
- 2 **Delayed** - indication that data in the window is delayed.
- 3 Own patient overview window

WARNING

All data presented in the own patient overview window are delayed for several seconds.

If you need realtime data, for example for defibrillation, always use the host monitor ECG instead of telemetry or ECG from another monitoring device. As long as the ECG is being measured with another device there will be no ECG signal available at the ECG analog output.

Visual Alarm Status Information in the Own Patient Overview Window

- If individual measurement alarms are switched off at any of the devices in use for the patient, a crossed alarm symbol on a white background is shown beside the measurement numeric 
- If all alarms are switched off or paused for one of the devices in use for the patient, a crossed alarm symbol on a dark gray background is shown beside all affected measurement numerics (if so configured). If all red and yellow alarms are switched off/paused, the crossed alarm symbol is red. If only yellow alarms are switched off/paused, the crossed alarm symbol is yellow. 

Controlling Other Devices from the Bedside

You can change ECG settings for the current ECG source from the patient monitor.

- 1 Select the own patient overview window.
- 2 Select the **Setup Equipm.** pop-up key.

A setup menu will appear with the settings available for the current ECG source. If it is a telemetry transmitter or patient monitor connected to the Information Center via LAN or WLAN, the following settings are available: adjust HR alarms, relearn arrhythmia, select primary/secondary ECG lead, select arrhythmia analysis mode, change primary/secondary ECG lead size. PIIC iX only: if the current ECG

source is a patient monitor connected to the Information Center via IntelliVue Instrument Telemetry (IIT), only the adjust HR alarms setting is available.

Viewing and Silencing Other Device Alarms at the Bedside

When other devices are assigned to the patient, alarms from those devices will also be indicated on the monitor, in addition to the main indication at the Information Center.

If configured, a generic alarm message will appear in the alarm status area with standard alarm tones. The alarm message will have the color and * or ! coding corresponding to the severity of the alarm. The specific alarm message (for example **** HR Low**) will appear in the own patient overview window.

If configured, alarms generated from another device can be silenced at the bedside. Either the monitor **Silence** key is configured to silence both monitor and other device alarms (must be configured at the Information Center) or the **Silence Bed** pop-up key will be available:

- 1 Select the own patient overview window.
- 2 Select the **Silence Bed** pop-up key.

Depending on your Information Center configuration, the **Silence Bed** key may silence both other device alarms **and** bedside alarms.

WARNING

Even when the other device data is not visible on the screen, you may be silencing monitor alarms **and** other device alarms, if the Information Center and monitor are so configured.

Switching Off or Pausing Alarms From Other Devices

When you select **Pause Alarms** or **Alarms Off** at the monitor, the alarms are off or paused for the bedside measurements. When you switch alarms off or pause alarms at the Information Center, both monitor alarms and alarms from other assigned devices are affected.

Refer to the Information Center Instructions for Use for more details on the Suspend/Pause alarms behavior of the Information Center.

Using Standby

When you select Standby mode at the monitor, the bedside goes into Standby mode but other assigned devices may continue monitoring.

Refer to the Information Center Instructions for Use for details on how selecting Standby at the Information Center affects the monitor and other devices.

ECG Source Tracking at the Information Center

The Information Center continuously checks whether a valid ECG signal is coming from the monitor or from another assigned device. If you unplug the ECG patient cable from the monitor and plug it into another device, the Information Center will automatically switch to monitoring the ECG from the other device. At the monitor, its own ECG measurement will be deactivated and the **Setup ECG** menu will no longer be accessible.

When you unplug the patient cable from the other device and plug it back into the monitor again, the Information Center will switch back to monitoring the ECG from the monitor.

The ECG measurement will be activated again at the monitor. [Note that in this case, as the screen switches back to the monitor's own measurements, the SpO₂T measurement (if present) will no longer be displayed].

In the same way the source is tracked when a telemetry device is directly connected to a monitor, then disconnected and vice versa.

In case of ambiguity, a yellow INOP message **!!Check ECG Source** indicates that more than one valid ECG source is active.

Synchronized Settings

For some measurements, settings can be synchronized between the monitor and another measurement device. For example, if ECG is measured at the monitor, and then the patient is connected to a telemetry device for monitoring, the Information Center will use the monitor settings for the telemetry device. In general, the following settings will be synchronized:

Heart Rate	HR/Pulse Alarm On/Off, Heart Rate High/Low Limit,
ECG	ECG On/Off ¹ , Primary Lead, Secondary Lead, Va Lead ² , Vb Lead ² , Lead Placement
Arrhythmia	Analysis Mode, Arrhythmia On/Off, Asystole Threshold, Pause Threshold, VTach HR, VTach Run, PVCs/min, Vent. Rhythm, SVT HR, SVT Run, PVCs/min On/Off, Pacer not capture On/Off, Pacer not pace On/Off, Non-Sustain On/Off, Vent. Rhythm On/Off, Run PVCs On/Off, Pair PVCs On/Off, Missed Beat On/Off, Pause On/Off, R-on-T PVCs On/Off, Vent. Bigeminy On/Off, Vent. Trigeminy On/Off, Multiform PVCs On/Off, Irregular HR On/Off, SVT On/Off, Afib On/Off, Afib/IrrHR End Threshold, All ECG Alarm INOP mode.
ST	ST Analysis On/Off, ST Alarm On/Off, ISO Point, J point, ST point, ST Alarm Limits, ST-Index On/Off, ISO/J-Point Detection, ST Lead On/Off, ST Baseline
QT	QT analysis On/Off, QT Lead, QTc High Alarm On/Off, ΔQTc Alarm On/Off, QTc High Limit, ΔQTc High Limit, QT Baseline ³
SpO ₂ T	SpO ₂ Alarms on/off, SpO ₂ Alarm limits, SpO ₂ Low Alarm Delay, SpO ₂ High Alarm Limit, Desat Alarm Limit NBP Alarm Suppression On/Off, Pulse(SpO ₂) On/Off
¹ ECG On/Off setting is forced to ON by the monitor, if the local setting is ON. ² Va and Vb leads are reset to default (V2, V5) if the configured Va or Vb lead for the telemetry device is not one of V1 through V6. ³ With PIIC, QT baseline is synchronized, but not QT snippets.	

PIIC iX With the IntelliVue Information Center iX, the following additional measurement settings can be synchronized:

ECG/Arrhythmia	Some ECG Alarms INOP On/Off
ST	STE On/Off, STE Alarm On/Off
NBP	Sys/Dia/Mean Alarm Limits, Alarms On/ Off, Alarm Source
Resp	Apnea Time, Alarm Limits, Alarm On/Off, Resp On/Off

SpO ₂	SpO ₂ Alarms on/off, SpO ₂ Alarm limits, Desat Alarm Limit, NBP Alarm Suppression On/Off, Pulse(SpO ₂) On/Off, Measurement Mode ¹ , Repetition Time ¹
¹ Measurement Mode and Repetition Time can only be synchronized if SpO ₂ comes from a Cableless SpO ₂ Pod or a telemetry device.	

WARNING

- Not all settings are synchronized; after changing the measurement source, always check that the settings are appropriate.
- **ECG:** Va and Vb leads are reset to default (V2, V5) if the configured Va or Vb lead for the telemetry device is not one of V1 through V6.

If later the patient is disconnected from the other device, and reconnected to the monitor again, any changes in the settings made in the meantime will be passed on to the monitor. In this way, settings continuity is preserved when the measurement source changes.

NOTE

Settings synchronization can be switched off at the monitor in Configuration mode.

In certain situations, you will be asked to confirm that synchronization of settings is appropriate.

Settings synchronization can only take place when there is no patient information mismatch between the monitor and the Information Center.

PIIC If a **Check ECG Settings** or **!! Check Pairing** INOP appears always check that the ECG settings, especially the paced setting, are appropriate for your patient.

PIIC iX If a **Check ECG Settings**, **Chk SpO₂T Settings**, or another check settings INOP appears, always check that the settings, especially the paced setting for ECG, are appropriate for your patient.

Care Groups

If your monitor is connected to an Information Center, you can group bedside monitors into Care Groups to facilitate caregiver assignment. This lets you:

- view information on the monitor screen from another bed in the same or in a different Care Group.
- be notified of yellow or red alarm conditions at the other beds in the Care Group.
- see the alarm status of all the beds in the Care Group on each monitor screen.

The functions available with Care Groups depend on the Information Center revision your monitors are connected to. See your Information Center Instructions for Use for further details.

Care Groups in PIIC iX

Units and Care Groups can be configured at the Information Center. The available sizes for units and Care Groups are defined by the Information Center. Monitors can be added to or removed from an existing care group at the monitor by assigning a new caregiver.

Care Groups in PIIC

There are two main types of Care Groups:

- standard care group (**Bed-based Care Group**) - up to 12 patients monitored by up to 4 Information Centers
- unit group (**Unit-based Care Group**) - for a complete unit with up to 64 patients monitored by up to 4 Information Centers

Care Groups are configured at the Information Center. Monitors can be added to or removed from an existing care group at the monitor. There is a third care group which can be assigned locally at the bedside. This is the **My Central** care group which includes all beds (up to 16) from the Information Center your bed is connected to. This care group setting is typically used in facilities with only one Information center. The selection of beds is automatic and cannot be changed.

Understanding the Alarm Status Overview Bar



The Care Group monitors' and equipment status is shown in symbol form in the Alarm Status overview bar. Flashing symbols indicate active alarms, symbols that are not flashing indicate alarms that have been acknowledged. Selecting a bed symbol calls up the window for that bed or a setup window to select it. Because multiple equipment can be used for one patient, it can occur that the alarm status is different at different devices. The alarm status will then be consolidated and the highest priority alarm information will be displayed.

The Alarm Status overview bar must be configured to display on the monitor Screen. If it is not visible on your monitor, select a Screen which has been configured to show the bar. Some screens may show the Care Group monitors grouped together in a tabular format on the right hand side of the screen.





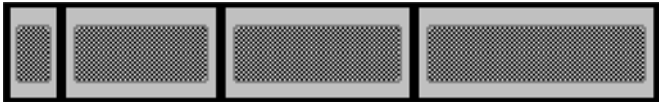
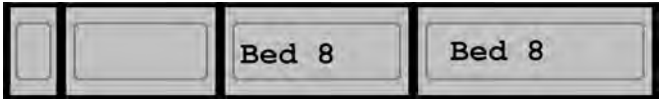
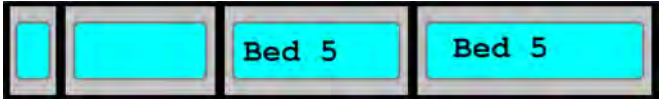







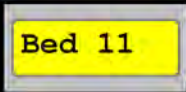



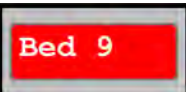
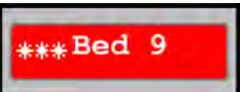





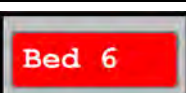
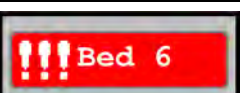

PIIC iX Depending on the Information Center configuration, the Alarm Status overview bar may contain My Patients (your own care group), My Unit (all beds from the unit) or it may not display at all.



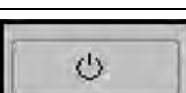
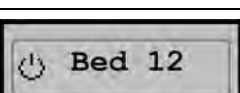

WARNING

With PIIC iX, the alarm status overview bar is independent from the configured alarm pop-up behavior.

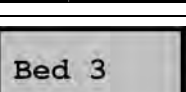
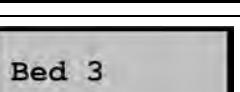
Alarm Status Symbols (four alternative display possibilities depending on space available)	
	No data from this bed
	The alarms are on but there are no currently active alarms from this bed
	The highest priority alarm from this bed is a standard INOP
	The highest priority alarm from this bed is a short yellow alarm

5 Managing Patients and Equipment

Alarm Status Symbols (four alternative display possibilities depending on space available)				
				The highest priority alarm from this bed is a yellow alarm
				The highest priority alarm from this bed is a red alarm
				The highest priority alarm from this bed is a yellow INOP
				The highest priority alarm from this bed is a red INOP
				The alarms at this bed are suspended. The same symbols in yellow indicate that yellow alarms are suspended (PIIC iX only).
				Equipment at this bed is in standby mode
				Equipment at this bed is in Demonstration mode
				The current bed

Connection Symbols (used in the Alarm Status overview bar and the My Patients window)		
		This is a telemetry bed.
		This bed is on a wireless network.
		This bed is on a wired network.
		PIIC iX only: Patient has multiple devices assigned.
		PIIC only: This is a "paired" bed, with a bedside monitor and a telemetry transmitter assigned.

Viewing the My Patients Window

This window shows the alarm status, bed name, and patient name for every bed in the Care Group.

The window for the Unit group shows first the beds of the Information Center this bed is connected to. By selecting the Information Center name at the top of the list, you can display a list of all Information Centers associated with the Unit group, and select another Information Center to view.

To enter the **My Patients** window,

- select the **Other Patients** SmartKey, if configured, or
- in the **Main Setup** menu, select **My Patients**.

Use the **My Patients** pop-up keys to navigate through the Care Groups:

My Unit lets you view a list of all the Information Centers in your Care Unit. Select an Information Center to see a list of the monitors connected to it. Select any monitor to see the Other Patient window for that bed.

Alarming Beds lets you view a list of all beds in your care group with an unacknowledged alarm. The beds are listed in order of alarm severity.

PIIC Other Units lets you view a list of all the Care Units in your Care Domain. Select any Care Unit to view a list of the Information Centers connected to it. Select an Information Center to see a list of the monitors connected to it. Select any monitor to see the Other Bed window for that bed.

PIIC iX Other Patients lets you search for a patient or step through lists by unit and bed label to select another patient.

Viewing the Other Bed Window

The Other Bed window lets you view a subset of the waveform and numeric information from another bed on the same network. Waves and numeric information from another bed are delayed. If configured, Other Bed information is displayed in color, using the colors defined by the Information Center.

The Other Bed window can be configured to pop-up automatically when an alarm occurs at another bed. To avoid too many windows appearing (for example, in large care groups) and covering the monitor's own bed data on the screen, you can temporarily disable this automatic pop-up:

- 1 Select **Main Setup** then **Network** followed by **Auto Window**
- 2 Select **Disabled**

When automatic pop-up is disabled in this way, an icon will appear as a reminder in the Care Group

Overview Bar next to the monitor's own bed label . Depending on the configuration, the automatic pop-up is disabled for five minutes or until you set it to **Enabled** again.

- To open the Other Bed window, select the required bed label or patient name in the Alarm Status Overview Bar. If you are in a Unit Group with many beds, the **My Patients** window may open for you to select the bed.

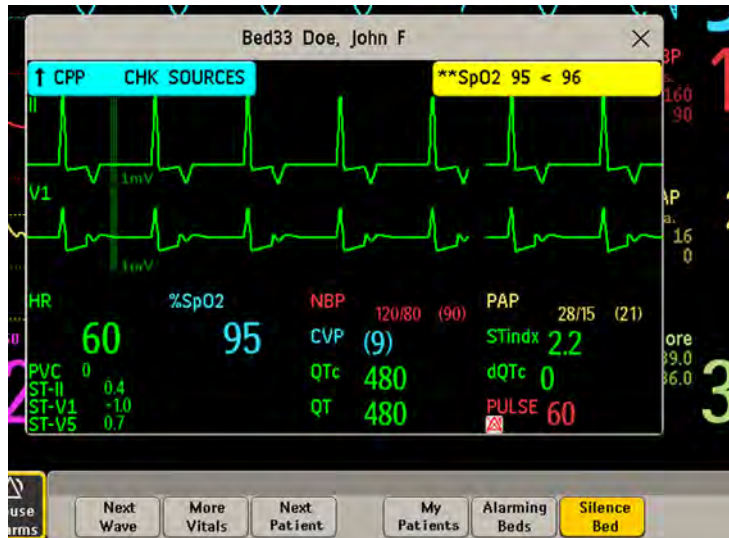

The Other Bed window may be configured to display embedded in a specially designed Screen.

- To display the embedded Other Bed screen element, in the **Change Screen** menu, select a Screen designed to show the Other Bed information permanently.

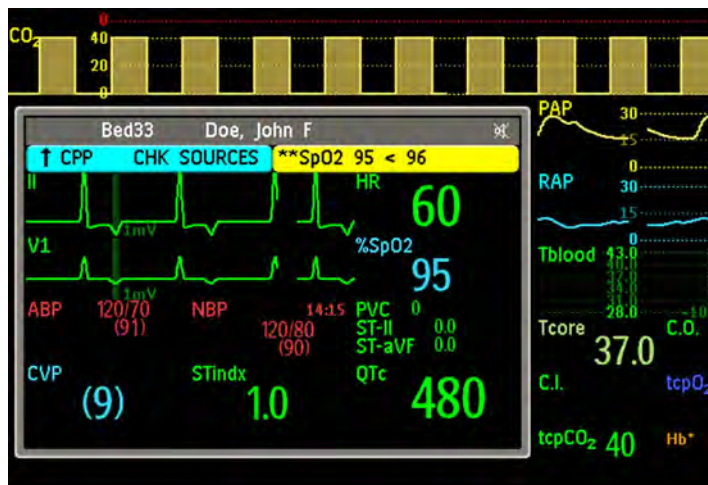

Changing the Screen may automatically change the bed shown in the other bed window. If you switch to a different Screen, you should check that the correct other bed is displayed.

Other Bed Pop-Up Keys

Select the **Other Patients** SmartKey or the Other Bed window or embedded screen element to access the associated pop-up keys:

Next Wave lets you view waveforms not currently shown in the other bed window.

More Vitals lets you view more numerics not currently shown in the other bed window.

Next Patient lets you view waveforms and numerics from the next available patient in the Care Group.

My Patients lets you call up the **Care Group** window to select another patient.

Alarming Beds lets you view a list of all beds in your care group with an unacknowledged alarm. The beds are listed in order of alarm severity. With PIIC iX, the **Alarming Beds** window may also contain beds that are not in your Care Group that have been escalated for higher attention.



Silence Bed lets you silence active alarms at the other bed. (Whether you see this key depends on the revision and configuration of the Information Center your monitors are connected to.)

WARNING

The **Silence Bed** pop-up key in the Other Bed window silences alarms at a remote bed. Be aware that accidental use of this key could silence alarms for the wrong patient.

To silence own bed alarms use the Silence permanent key on screen.

Visual Alarm Status Information in the Other Bed Window

- If individual measurement alarms are switched off at any of the devices in use at the other bed, a crossed alarm symbol in red on a white background is shown beside the measurement numeric. 
- If all alarms are switched off or paused for one of the devices in use at the other bed, a crossed alarm symbol on a black background is shown beside all affected measurement numerics (if so configured). If all red and yellow alarms are switched off/paused, the crossed alarm symbol is red. If only yellow alarms are switched off/paused, the crossed alarm symbol is yellow. 
- In the embedded Other Bed window, the crossed speaker symbol in the upper right hand corner indicates that the volume of the audible alarm status change notification for the other beds in the care group is set to zero at the overview monitor. 

Other Patient Alarms

Changes in the alarm status of beds in a Care Group are announced visually and audibly at all other beds in the same Care Group. The visual and audible indicators used depend on the monitor and Information Center configuration.

When an alarm is detected at another bed in the Care Group,

- the alarm status is shown in the Alarm Status overview bar as an icon.
- a message informing you about the other patient alarm is shown in the monitor status line.

- if configured, the Other Bed window, the **Alarming Beds** window or the **My Patients** window may pop up on the Screen (if automatic alarm notification is enabled at the bedside monitor and at the Information Center). The automatic alarm notification is suppressed when a window, menu or pop-up keys are active.
- if configured, an audible status change notification is issued. The tone type and volume can be configured.

PIIC iX Automatic alarm notification can also cause a window to pop-up when a patient from outside the Care Group has been escalated to a higher attention status. Check that the detailed configuration at the PIIC iX meets your unit's requirements.

Automatic alarm notification can be switched off permanently in the monitor's Configuration Mode or at the Information Center.

Information Center Compatibility

The functionality available for managing patients and equipment depends on the IntelliVue Information Center being used. In the following table the main differences between the PIIC and PIIC iX are shown.

PIIC	PIIC iX
Not available	Find Patient - searching for a patient in the Information Center or other connected hospital systems. (With LAN and WLAN connection only)
Transfer Patient - patient is moved to transfer list.	Transfer Patient - can transfer patient directly to another bed/unit and from another bed/unit. (With LAN and WLAN connection only)
Not available	A unique patient list provides information about the current status of a patient allowing intelligent prompts and preventing the same patient being admitted twice.
Add Equipment - allows only assignment of telemetry devices via manual pairing.	Add Equipment - allows assignment of other monitors, telemetry devices and X2 MMS. (With LAN and WLAN connection only)
Remove equipment - allows only removal of telemetry devices via Unpair To Mon. and Unpair To Tele.	Remove equipment - allows removal of other monitors, telemetry devices and X2 MMS.
Not available	Select Location - allows a temporary location to be shown when a patient is not in the unit. (With LAN and WLAN connection only)
Not available	Select Caregiver - allows a Caregiver to be assigned to a patient
Not available	Paced status Unconfirmed is the initial setting before a paced status has been entered. Unconfirmed will switch pace pulse rejection on but makes the user aware that no paced status has been selected.

ECG, Arrhythmia, ST and QT Monitoring

The electrocardiogram (ECG) measures the electrical activity of the heart and displays it on the monitor as a waveform and a numeric. This section also tells you about arrhythmia monitoring (see “About Arrhythmia Monitoring” on page 154), ST monitoring (see “About ST Monitoring” on page 164) and QT monitoring (see “About QT/QTc Interval Monitoring” on page 175).

Skin Preparation for Electrode Placement

Good electrode-to-skin contact is important for a good, noise-free ECG signal, as the skin is a poor conductor of electricity.

- 1 Select sites with intact skin, without impairment of any kind.
- 2 Clip or shave hair from sites as necessary.
- 3 Wash sites thoroughly with soap and water, leaving no soap residue.
We do not recommend using ether or pure alcohol, because this dries the skin and increases the resistance.
- 4 Dry skin thoroughly.

Connecting ECG Cables

- 1 Attach the clips or snaps to the electrodes before placing them. If you are not using pre-gelled electrodes, apply electrode gel to the electrodes before placement.
- 2 Place the electrodes on the patient according to the lead placement you have chosen.
- 3 Attach the electrode cable to the patient cable.
- 4 Plug the patient cable into the white ECG connector. An ECG waveform and numeric appears on the monitor display.

CAUTION

To protect the monitor from damage during defibrillation, for accurate ECG information and to protect against noise and other interference, use only ECG electrodes and cables specified by Philips. Some non-authorized electrodes may be subject to large offset potentials due to polarization.

Selecting the Primary and Secondary ECG Leads

The monitor uses the primary and secondary lead to compute HR and to analyze and detect cardiac arrhythmias. They are also available for recordings and for display on the Information Center.

The secondary lead is only used if your monitor is configured for multi-lead (instead of single-lead) arrhythmia analysis.

You should choose a lead as primary or secondary lead that has the following characteristics:



- the QRS complex should be either completely above or below the baseline and it should not be biphasic
- the QRS complex should be tall and narrow
- the P-waves and T-waves should be less than 0.2 mV

To select a lead as primary or secondary lead:

- In the **Setup ECG** menu, select **Primary** or **Secondary**, then select the appropriate lead. You can assign any available lead whether it is currently displayed or not.

Checking Paced Mode

It is important to set the paced mode correctly when you start monitoring ECG.

- To change the paced mode in the **Setup ECG** menu, select **Paced Mode** to switch between **On**, **Off** or **Unconfirmed**.

WARNING

Pace pulse rejection must be switched on for paced patients by setting **Paced Mode** to **On**. Switching pace pulse rejection off for paced patients may result in pace pulses being counted as regular QRS complexes, which could prevent an asystole event from being detected. When changing profiles, and at admission/discharge, always check that paced mode is correct for the patient.

Some pace pulses can be difficult to reject. When this happens, the pulses are counted as a QRS complex, and could result in an incorrect HR and failure to detect cardiac arrest or some arrhythmias. Make sure that pace pulses are detected correctly by checking the pace pulse markers on the display. Keep pacemaker patients under close observation.

Understanding the ECG Display

Your display may be configured to look slightly different.



- 1 Lead label of the displayed wave
- 2 1 mV calibration bar
- 3 Pacer spikes
- 4 Pace pulse markers
- 5 Current heart rate
- 6 Current heart rate alarm limits and paced mode symbol
- 7 EASI lead placement label (located here when present)
- 8 ECG Filter label

ECG HR numeric: This is the heart rate derived from the monitored ECG.

Pace pulse markers: These are shown if the **Paced Mode** status has been set to **On**, the pacer spikes are not configured to have a fixed size, and the patient has a paced signal.

Pacer Spikes: The pacer spikes are shown in white, unless the ECG wave is white, then they will be green. If the pacer spikes have been configured to have a fixed size, they will be displayed in the background as a dotted line.

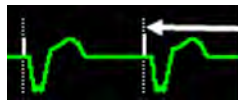

- 1 Pacer spikes configured to have a fixed size

Defibrillator synchronization marks: If an HP/Agilent/Philips defibrillator is connected, or the 2nd Sync Out channel is configured to **ECG SyncPuls** and a sync cable is plugged in, the synchronization marks (vertical lines on the ECG wave) are shown on the ECG wave. The synchronization marks will be shown in yellow, unless the ECG wave is yellow, then they will be green.

ST numerics in ECG wave: ST numerics can be configured to show underneath the ECG wave on the left side.

Monitoring Paced Patients

An ECG optimized for monitoring a paced patient should look like this:



- 1 Normal Beats
- 2 Pace Pulses/Pace Beats

You should choose a lead as primary or secondary lead that has these characteristics:

- the normal QRS complex should be either completely above or below the baseline and it should not be biphasic. For paced patients, the QRS complexes should be at least twice the height of pace pulses.
- the QRS complex should be tall and narrow
- the P-waves and the T-waves should be less than 0.2 mV.

For ease of identification on the screen, the pacer spikes can be configured to have a fixed size. They are then shown in the background as a dotted lines. The length of the dotted line is fixed to the wave channel height and is independent of the actual pacer amplitude.

Setting the Paced Mode (Pace Pulse Rejection)

In the **Setup ECG** menu, select **Paced Mode** to switch between **On**, **Off** or **Unconfirmed**.

You can also change the paced mode in the **Patient Demographics** window.

When **Paced Mode** is set to **On**:

- Pace Pulse Rejection is switched on. This means that pacemaker pulses are not counted as extra QRS complexes.
- pace pulse marks are shown on the ECG wave as a small dash (only when the pacer spikes are not configured to have a fixed size).
- The paced symbol is displayed next to the HR numeric.

When **Paced Mode** is set to **Off**, pacer spikes are not shown in the ECG wave. Be aware that switching pace pulse rejection off for paced patients may result in pace pulses being counted as regular QRS complexes, which could prevent an asystole event from being detected.

When the paced mode has not yet been set for a patient, the paced symbol will have a question mark indicating the **Unconfirmed** mode. When the paced mode is **Unconfirmed**, pace pulse rejection is switched on.

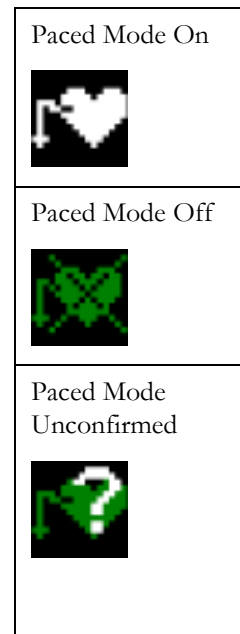

Avoiding Pace Pulse Repolarization Tails

Some unipolar pacemakers display pace pulses with repolarization tails. These tails may be counted as QRSs in the event of cardiac arrest or other arrhythmias.

If you note a visible repolarization tail, choose a lead that decreases the size of the repolarization tail.

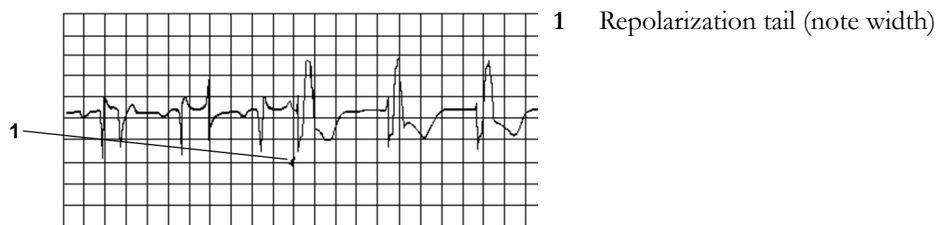

Changing the Size of the ECG Wave

If any of the displayed ECG waves is too small or clipped, you can change the size of one or all of the ECG waves on the screen.

Changing the adjustment factor only changes the visual appearance of the ECG wave on the screen. It does not affect the ECG signal analyzed by the monitor.

Comparing the wave size to the 1 mV calibration bar on the ECG wave segment can help you to get an idea of the true ECG signal strength. If you choose a fixed adjustment factor, the 1 mV calibration bar will be the same size for all the displayed ECG waves. If you choose **Auto Size**, or an individual size using the **Size Up/Size Down** keys, the calibration bar may be a different size for each wave.

To Change the Size of an Individual ECG Wave

- 1 Select the wave segment you want to change. This calls up the lead menu for this segment.
- 2 In the lead menu, select **Size Up** to increase wave size or **Size Down** to decrease the size. Selecting **Auto Size** lets the monitor choose the optimal adjustment factor for all available ECG waves.

To Change the Size of all the ECG Waves

To change the size of all the ECG waves on the screen by a fixed adjustment factor,

- 1 In the **Setup ECG** menu, select **Adjust Size**.
- 2 Select the required adjustment factor from the line of pop-up keys.
 - **Size x0.5** to halve the wave size
 - **Size x1** to display the wave without zoom
 - **Size x2** to double the wave size
 - **Size x4** to multiply the wave size by four
 - **Previous Size:** to return one step to the previous size
 - **Auto Size:** to let the monitor choose the optimal adjustment factor for all the ECG waves.

Changing the Volume of the QRS Tone

The QRS tone is derived from either the HR or Pulse, depending on which is currently selected as the alarm source. The QRS volume can be set from 0 to 10 (0 means off).

To change the QRS volume, in the **Setup ECG** menu select **QRS Volume** and then select the appropriate volume from the pop-up list.

Changing the ECG Filter Settings

The ECG filter setting defines how ECG waves are smoothed. An abbreviation indicating the filter type is shown underneath the lead label on the monitor display. Filter settings do not affect ST measurement.

To change the filter setting, in the **Setup ECG** menu, select **Filter** and then select the appropriate setting.

- **Monitor:** Use under normal measurement conditions.
- **Ext. Monitor:** Use when diagnostic quality is required but low frequency interference or a wandering baseline may be expected. The upper edge frequency is the same as the **Diag** setting and the lower edge frequency is the same as the **Monitor** setting.

- **Filter:** The filter reduces interference to the signal. It should be used if the signal is distorted by high frequency or low frequency interference. High frequency interference usually results in large amplitude spikes making the ECG signal look irregular. Low frequency interference usually leads to a wandering or rough baseline. In the operating room, the Filter reduces artifacts and interference from electrosurgical units. Under normal measurement conditions, selecting **Filter** may suppress the QRS complexes too much and thus interfere with the clinical evaluation of the ECG displayed on the monitor. This does not affect the ECG analysis performed by the monitor.

If **AutoFilter** is set to **On** in Configuration Mode, the filter setting will automatically be set to **Filter** if electromagnetic interference is detected.

- **Diag:** Use when diagnostic quality is required. The unfiltered ECG wave is displayed so that changes such as R-wave notching or discrete elevation or depression of the ST segments are visible.

The setting **Diag** selects the highest available ECG bandwidth which is 0.05 to 150 Hz for the Adult, Pedi and Neo patient category. The term "diagnostic" relates only to the ECG bandwidth requirements for diagnostic electrocardiographic devices as outlined in the ANSI/AAMI standard EC11-1991.

Selecting Positions of Va and Vb Chest Leads (for 6-lead placement)

The two chest leads for the 6-lead placement can be positioned at any two of the V1 to V6 positions. Select the positions you have used in the **Setup ECG** menu, so that the chest leads will be correctly labeled.

- 1 In the **Setup ECG** menu, select **Va Lead**.
- 2 Select the position used from the list.
- 3 Select **Vb Lead** and select the position used from the list.

Choosing EASI or Standard Lead Placement

You must enable either standard lead placement or EASI lead placement.

- In the **Setup ECG** menu, select **Lead Placement** and then **Standard** or **EASI**.

EASI is shown beside the 1 mV calibration bar on the ECG wave on the display, and **EASI** is marked on any recorder strips and printouts.

See the section on "EASI ECG Lead Placement" on page 145 for electrode placement diagrams.

About ECG Leads

To make it possible to compare measured ECG signals, the electrodes (or lead sets) are placed in standardized positions, forming so-called "leads". To obtain ECG signals optimized for use in diagnosis and patient management in different care environments, different lead sets in varying lead placements can be used. You can use either standard lead placements or EASI lead placements with this monitor.

When placing electrodes, choose a flat, non-muscular site where the signal will not be interfered with by either movement or bones. Correct lead placement is always important for accurate diagnosis.

Especially in the precordial leads, which are close to the heart, QRS morphology can be greatly altered if an electrode is moved away from its correct location.

ECG Leads Monitored

If you are using	these leads are available:	Resp is measured between electrodes:
a 3-electrode set	I, II, III	RA and LL
a 5-electrode set	I, II, III, aVR, aVL, aVF, V and MCL	RA and LL
a 6-electrode set	I, II, III, aVR, aVL, aVF, Va, Vb	RA and LL
a 10-electrode set	I, II, III, aVR, aVL, aVF, V1, V2, V3, V4, V5, V6	RA and LL
an EASI 5-electrode set	I, II, III, aVR, aVL, aVF, V1, V2, V3, V4, V5, V6	I and A

Changing Lead Sets

To change the ECG lead set,

- **When adding leads:** place the additional electrodes as required - the monitor automatically recognizes the new lead placement.
- **When removing leads:** there are two possibilities - removing the complete chest leads block or removing individual leads. If you unplug the chest lead block from the trunk cable connector, the monitor will automatically recognize the new lead placement. Remove individual leads by removing the electrodes. The monitor will issue a **Lead Off INOP** message; select **New Lead Setup** in the **Setup ECG** menu and the INOP message will disappear.

ECG Lead Fallback

If fallback is configured on and there is a leads off INOP in the primary lead (and in the secondary lead, if you are using multi-lead monitoring) for longer than 10 seconds, and if another lead is available, this available lead automatically becomes the primary lead. This is known as lead fallback. When the Leads Off condition is corrected, the leads are automatically switched back.

This setting can only be changed in Configuration Mode.

ECG Lead Placements

The labels and colors of the ECG electrodes differ according to the standards that apply for your hospital. The electrode placement illustrations in this chapter use the AAMI labels and colors.

Electrode labels			Electrode colors	
AAMI	EASI	IEC	AAMI	IEC
RA	I	R	White	Red
LA	S	L	Black	Yellow
LL	A	F	Red	Green
RL	N	N	Green	Black
V	E	C	Brown	White
V1		C1	Brown/Red	White/Red

Electrode labels			Electrode colors	
AAMI	EASI	IEC	AAMI	IEC
V2		C2	Brown/Yellow	White/Yellow
V3		C3	Brown/Green	White/Green
V4		C4	Brown/Blue	White/Brown
V5		C5	Brown/Orange	White/Black
V6		C6	Brown/Violet	White/Violet

Standard 3-Lead Placement

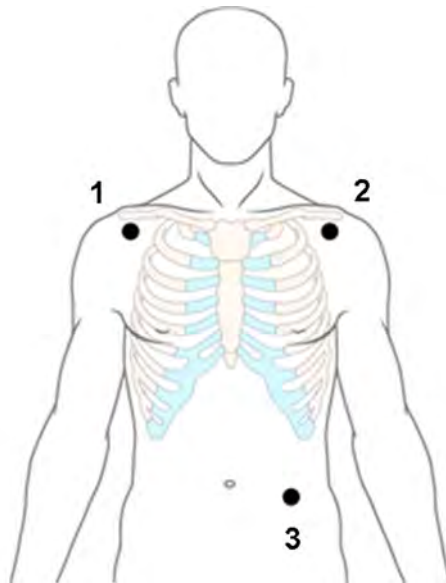

- 1 RA placement: directly below the clavicle and near the right shoulder
- 2 LA placement: directly below the clavicle and near the left shoulder
- 3 LL placement: on the left lower abdomen

Standard 5-Lead Placement

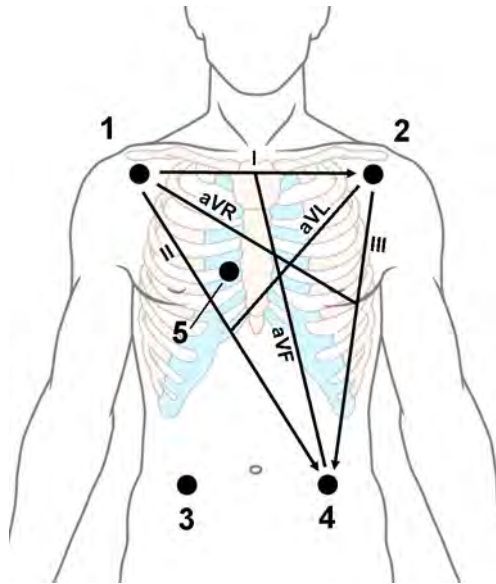

- 1 RA placement: directly below the clavicle and near the right shoulder
- 2 LA placement: directly below the clavicle and near the left shoulder
- 3 RL placement: on the right lower abdomen
- 4 LL placement: on the left lower abdomen
- 5 V placement: on the chest, the position depends on your required lead selection

6-Lead Placement

For a 6-lead placement use the positions from the 5-lead diagram above but with two chest leads. The two chest leads, Va and Vb, can be positioned at any two of the V1 to V6 positions shown in the chest electrode diagram below. The Va and Vb lead positions chosen must be selected in the **Setup ECG** Menu to ensure correct labeling.

Chest Electrode Placement

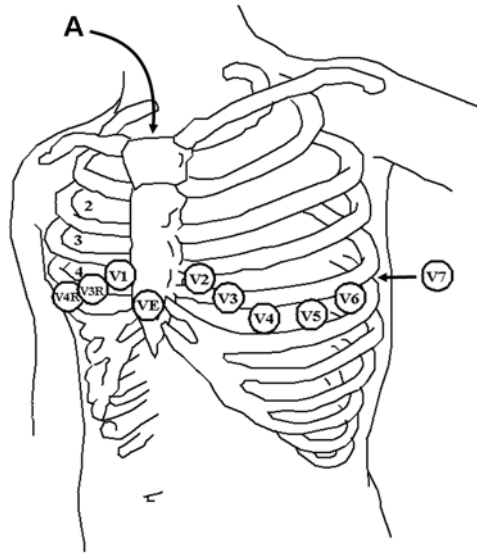

A - Angle of Lewis

V1 on the fourth intercostal space at the right sternal border

V2 on the fourth intercostal space at the left sternal border

V3 midway between the V2 and V4 electrode positions

V4 on the fifth intercostal space at the left midclavicular line

V5 on the left anterior axillary line, horizontal with the V4 electrode position

V6 on the left midaxillary line, horizontal with the V4 electrode position

V3R -V6R on the right side of the chest in positions corresponding to those on the left

VE over the xiphoid process

V7 on posterior chest at the left posterior axillary line in the fifth intercostal space

V7R on posterior chest at the right posterior axillary line in the fifth intercostal space

For accurate chest electrode placement and measurement, it is important to locate the fourth intercostal space.

- 1 Locate the second intercostal space by first palpating the Angle of Lewis (the little bony protuberance where the body of the sternum joins the manubrium). This rise in the sternum is where the second rib is attached, and the space just below this is the second intercostal space.
- 2 Palpate and count down the chest until you locate the fourth intercostal space.

10-Lead Placement

When monitoring 12-leads of ECG, using a 10-Electrode Lead Placement, it is important to correctly place electrodes and to label all 12-lead ECG reports with the correct lead placement.

Conventional 12-Lead ECG

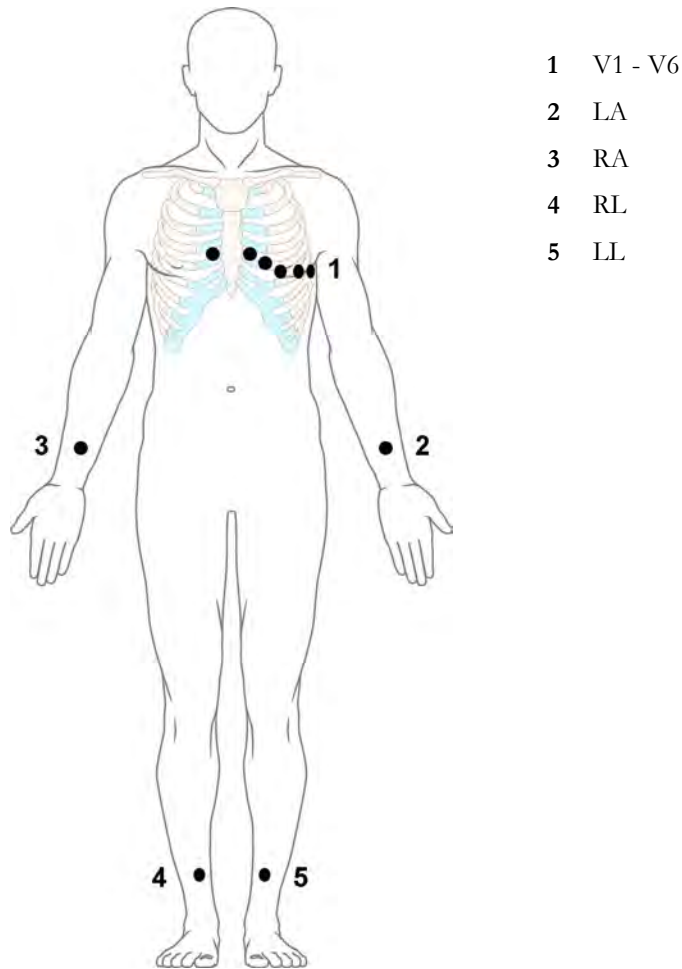

In conventional 12-Lead ECG using 10 electrodes, an electrode is placed on the right arm, left arm, right leg, and left leg. Six V- electrodes are placed on the chest. The right leg electrode is the reference electrode.

Limb electrodes:

- Place arm electrodes on the inside of each arm, between the wrist and the elbow.
- Place leg electrodes inside of each calf, between the knee and the ankle.

Chest electrodes:

V1 - on the 4th intercostal space at the right sternal border

V2 - on the 4th intercostal space at the left sternal border

V3 - midway between the V2 and V4 electrode positions

V4 - on the 5th intercostal space at the left midclavicular line

V5 - on the left anterior axillary line, horizontal with the V4 electrode position

V6 - on the left midaxillary line, horizontal with the V4 electrode position

Modified 12-Lead ECG

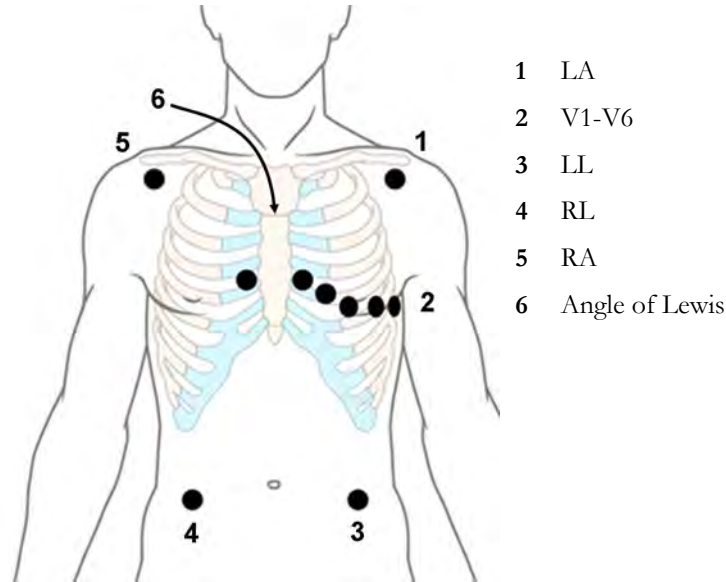

If your institution uses modified 10-lead ECG electrode placement (the Mason-Likar Lead System), place the four limb electrodes close to the shoulders and lower abdomen.

The six V electrodes are placed on the chest in the same position as the conventional 12-lead placement.

Choosing Standard or Modified Electrode Placement

If your institution uses modified 10 Lead ECG electrode placement (the Mason-Likar Lead System), you must switch **Mod.LeadPlacement** to **On** in the monitor. To do this,

- in the **Setup ECG** menu, select **Mod.LeadPlacement** to toggle between **On** and **Off**.
 - When **Mod.LeadPlacement** is set to **On**, 12 Lead ECG Reports will be labeled **12 Lead ECG Report (Mason-Likar)**, and captured 12-lead ECGs will be labeled **Mason-Likar** to the right of the bandwidth annotation at the Information Center.
 - When **Mod.LeadPlacement** is set to **Off**, 12 Lead ECG Reports will be labeled **12 Lead ECG Report (Standard)**, and captured 12-lead ECGs will not be annotated at the Information Center.

WARNING

Do not use ECG analysis interpretation statements and measurements for 12-lead ECGs obtained using the modified (Mason-Likar) limb electrode placement. This may lead to misdiagnosis since the modified (Mason-Likar) limb electrode placement does not look the same as the conventional 12-lead ECG and may mask inferior infarction due to calculated axis, R, P and T wave magnitudes shifts and ST slope.

Do not export 12-lead ECGs obtained using the modified (Mason-Likar) limb electrode placement. Captured 12-Lead ECGs using the modified (Mason-Likar) limb electrode placement exported from the Information Center are not annotated with the Mason-Likar label.

EASI ECG Lead Placement

Using a standard 5-electrode set in EASI lead placement you can monitor up to 12 standard ECG leads simultaneously and continuously at the bedside. EASI provides a monitoring method for trending ST segment changes that can provide an early indication of ischemia.

WARNING

EASI-derived 12-lead ECGs and their measurements are approximations to conventional 12-lead ECGs. As the 12-lead ECG derived with EASI is not exactly identical to the 12-lead conventional ECG obtained from an electrocardiograph, it should not be used for diagnostic interpretations.

Respiratory monitoring is also possible with the EASI placement; respiration is measured between the I and A electrodes.

Place the electrodes as accurately as possible to obtain the best quality EASI measurements.

When EASI lead placement is selected, **EASI** is shown beside the 1 mV calibration bar on the ECG wave on the display, and **EASI** is marked on any recorder strips and printouts.

EASI Monitoring During INOP Conditions

If one of the derived EASI leads has an INOP condition (for example, **Lead Off**), a flat line is displayed. After 10 seconds, the directly acquired EASI AI, AS, or ES lead (depending on which is available) is displayed with the corresponding lead label. This causes an arrhythmia relearn.

EASI Electrode Placement

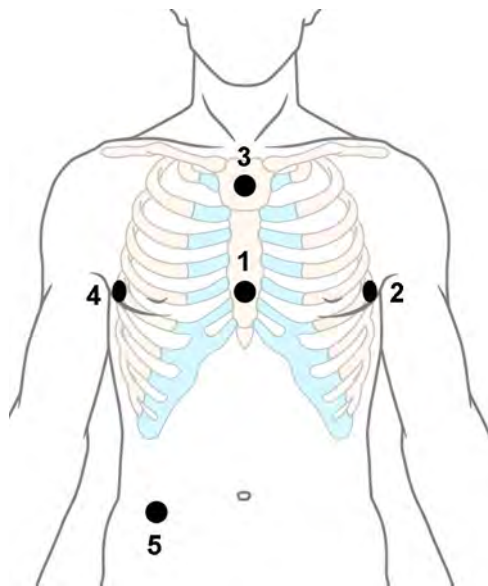

- 1 E (V) - on the lower sternum at the level of the fifth intercostal space
- 2 A (LL) - on the left midaxillary line at the same level as the E electrode
- 3 S (LA) - on the upper sternum
- 4 I (RA) - on the right midaxillary line at the same level as the E electrode
- 5 N - reference electrode - can be anywhere, usually below the sixth rib on the right hip

Capture 12-Lead

You can view a 12-Lead ECG on the screen, capture a 12-Lead ECG episode, preview the captured ECG data and then store it and send it to a connected Information Center for analysis. You can download the resulting analysis from the Information Center and also other 12-Lead captures for review at the monitor. A 12-Lead report can be printed that also includes the downloaded analysis results and an ST Map. You can operate the 12-Lead Export function and the 12-Lead Lock/Unlock function at the Information Center remotely from the monitor.

The monitor can store one 12-Lead ECG episode at any time.

Viewing the Realtime 12-Lead ECG

To open the 12-Lead ECG window and view the realtime ECG waves,

- Select the **Capture 12 Lead** SmartKey, or
- Select **Main Setup**, then **Capture 12 Lead**.

If a previously viewed 12-Lead ECG was not stored, a window will pop up asking whether you want to keep it or not. The title bar of the window shows the date and time when this 12-Lead ECG was captured. If you do not need the ECG, select **No** to discard it, otherwise, select **Yes** and then select **Store & Send** to store that 12-Lead ECG and send it to an Information Center (if one is connected).

If your patient is not admitted, you will be prompted to enter at least the age and gender of the patient. This information is needed for analysis of the 12-Lead ECG at the Information Center but is not essential if you only want to capture the 12-Lead ECG without sending it for analysis. To enter this information:

- 1 Select the **Admit Patient** pop-up key, then
- 2 Enter the information in the **Patient Demographics** window.
- 3 Open the 12-Lead ECG window again as described above.

The age and gender will now be displayed in the title bar of the pop-up keys.

To change the way the realtime waves are displayed, select the **Change View** pop-up key or select the wave area. You can switch between a one or two column display. The two column display lets you see a larger representation of the waves.

While the realtime 12-Lead waves are being viewed in the window, the ECG filter mode (see “Changing the ECG Filter Settings” on page 137) is changed to the 12-Lead filter setting (see “Changing Settings for a Captured 12-Lead ECG” on page 147).

Capturing the 12-Lead ECG

To capture the last 10 seconds of ECG data, select the **Capture Waves** pop-up key. The pop-up key is active as soon as enough wave data is available; until then a progress bar is displayed in the title bar of the pop-up keys. A preview of the captured data appears on the screen (unless your monitor is connected to an Information Center with software release earlier than Revision M — then the captured data is automatically stored and sent to the Information Center).

The title bar of the pop-up keys will now show the current filter setting and, if you are using EASI lead placement, an EASI indicator (see “EASI ECG Lead Placement” on page 145).

You can at any time return to the realtime 12-Lead ECG view by selecting the **Show Waves** pop-up key. From there, you return to the preview window by selecting the **Review 12 Lead** pop-up key and then selecting the 12-Lead marked with * from the list.

Changing Settings for a Captured 12-Lead ECG

Select the **Setup 12 Lead** pop-up key to choose settings for filter, gain, etc., if changes are needed. All changes apply to both the display and the printed 12-Lead report. The changes are only applied temporarily and will not be stored. If you want to change the default settings, see “Setting Up the 12-Lead ECG” on page 149.

High Pass Filter	Sets the high pass filter for the waveforms. Choices are 0.05 Hz , 0.15 Hz and 0.5 Hz .
Low Pass Filter	Sets the low pass filter for the waveforms. Choices are 40 Hz , 100 Hz and 150 Hz .
AC Filter	Switches the AC (line frequency) filter On or Off .
Gain	Defines the gain used for the waveforms. Choices are 2.5 mm/mV , 5 mm/mV , 10 mm/mV and 20 mm/mV .
Chest Gain	Defines the gain for the chest leads relative to the standard gain setting. Choices are Full and Half .
Paper Speed	Defines the waveform speed. Choices are 25 mm/sec and 50 mm/sec .
Format	Defines the page layout. Choices are 12x1 , 6x2 , 3x4 , 3x4 1R , 3x4 3R , 3x4 ST and 3x4 1R ST . 1R and 3R refer to 1 or 3 rhythm leads, ST formats contain an ST map.
Time	Defines whether all leads show simultaneous or sequential intervals of time, when displaying or printing 2 or more columns. Choices are Sequential and Simultaneous .
Rhythm Lead 1 Rhythm Lead 2 Rhythm Lead 3	Defines which lead will be used as rhythm lead 1, 2 or 3. Choices are Primary , Secondary , I , II , III , aVR , aVL , aVF , V1 , V2 , V3 , V4 , V5 , V6 , MCL This setting is only relevant when 3x4 1R , 3x4 1R ST or 3x4 3R is selected as Format .
Lead Sequence	Defines the sequence in which the leads are presented. Choices are Cabrera and Internat .

Storing and Sending the 12-Lead ECG

You can enter an order number that will then be associated with the 12-Lead ECG. To enter an order number, select the **Enter OrderNo.** pop-up key. The order number will be displayed in the title bar of the pop-up keys.

To store the previewed data on the monitor and send it to a connected Information Center for storage and analysis, select the **Store & Send** pop-up key. If the monitor is connected to an Information Center, use the **Store & Send** function before patient transport to store the 12-Lead ECG centrally, as the 12-Lead ECG data will not be uploaded from the MMS to another monitor after transport.

If the connection to the Information Center is not active while storing, the 12-Lead ECG will be automatically sent as soon as the connection is established or restored. If a previously stored 12-Lead ECG is waiting to be sent to the Information Center, it will be overwritten when a new 12-Lead ECG is stored and can then not be sent to the Information Center.

Printing the 12-Lead ECG

Print a dedicated 12-Lead ECG report by selecting the **Print Report** pop-up key.

When you are working with an Information Center iX that provides 12-Lead analysis, the report contains the 12-Lead analysis results as well as measurement values (e.g. ST values, QT values, HR) which are also downloaded from the Information Center iX. If you work with an Information Center which does not provide any 12-Lead analysis results, the report only contains the measurement values. In this case, however, the values are based on the real-time measurements made at the bedside. Consequently, the measurement values in the report might differ in the two cases, due to the slightly different algorithm approaches of patient monitor (real-time measurement) and Information Center iX (diagnostic interpretation of 12-Lead capture).

Downloading Analysis Results (PIIC iX only)

Download analysis results from the IntelliVue Information Center by selecting **Show Analysis**. Return to the previous screen by selecting **Hide Analysis**.

Reviewing Previewed or Stored 12-Lead Captures

To view 12-Lead captures previewed or stored on the monitor or 12-Lead captures stored at the IntelliVue Information Center (PIIC iX only), select **Review 12 Lead**. You can then select from a list of 12-Lead captures available for the current patient.

The 12-Lead captures in the list may be marked with a symbol, for example an open or closed padlock to indicate unlocked or locked status or a * to indicate preview status.

Information Center Remote Export (PIIC iX only)

Use the **Export** key to remotely start the 12-Lead export functionality of the IntelliVue Information Center.

Information Center Remote Lock/Unlock (PIIC iX only)

Use the **Lock** key to remotely lock the 12-Lead capture at the IntelliVue Information Center. If it is already locked, the **Unlock** key will be displayed.

Capture 12-Lead Pop-up Keys

Here is a summary of all the pop-up keys available during the 12-Lead ECG procedure:

Pop-up Keys	Selecting this pop-up key lets you
Admit Patient	enter the age and gender for the patient, to allow analysis of the 12-Lead ECG.
Change View	switch between the single column and two-column display of the realtime wave data.
Capture Waves	capture the current ECG waves and open the preview window.
Show Waves	return to the realtime 12-Lead ECG view.
Setup 12 Lead	choose settings for filter, gain, display layout, etc.
Enter OrderNo.	enter an order number that is stored with the capture and displayed in the title bar of the pop-up keys.
Print Report	print a 12-Lead report.

Pop-up Keys	Selecting this pop-up key lets you
Store & Send	store the captured 12-Lead ECG in the monitor and send it to the Information Center.
Review 12 Lead	view a list of 12-Lead captures available at the monitor or at the IntelliVue Information Center, and select one for review.
Show Analysis	download analysis results from the IntelliVue Information Center
Export	remotely export 12-Lead ECG data from the IntelliVue Information Center to an ECG management system (see the Information Center Instructions for Use for details).
Lock / Unlock	remotely lock/unlock the 12-Lead capture at the IntelliVue Information Center.

Setting Up the 12-Lead ECG

You can make settings that will be stored and used in future as default settings for each 12-Lead ECG capture made.

- 1 Select the HR numerics on the screen to enter **Setup ECG**.
- 2 Select **12Lead**.
- 3 The **Setup 12 Lead** window opens for you to make the default settings.

For a description of the available settings, see “Changing Settings for a Captured 12-Lead ECG” on page 147.

ECG and Arrhythmia Alarm Overview

The ECG and arrhythmia alarms available depend on which measurements are switched on, and the arrhythmia option enabled for your monitor.

- Cardiotach alarms are available when HR is on and the active alarm source is ECG, but Arrhythmia is switched off
- Basic arrhythmia alarms are available when Arrhythmia is switched on
- Enhanced arrhythmia alarms are available when Arrhythmia is switched on and the Enhanced Arrhythmia option has been enabled for your monitor

Alarm	Description	Arrhythmia Configuration		
		Arrhythmia Off	Basic Arrhythmia	Enhanced Arrhythmia
*** Asystole	No QRS detected for a period > the asystole alarm threshold	x	x	x
*** Vent Fib/Tach	Fibrillatory waveform (sinusoidal wave between 2 – 10 Hz) for 4 consecutive seconds	x	x	x
*** VTach	A run of PVCs \geq the V-Tach run limit and heart rate > the V-Tach HR limit		x	x
*** Extreme Tachy	Heart rate > the extreme tachy alarm limit	x	x	x

Alarm	Description	Arrhythmia Configuration		
		Arrhythmia Off	Basic Arrhythmia	Enhanced Arrhythmia
*** Extreme Brady	Heart rate < the extreme brady alarm limit	x	x	x
** HR High	Heart rate > the high HR alarm limit	x	x (see note)	x (see note)
** HR Low	Heart rate < the low HR alarm limit	x	x (see note)	x (see note)
** Non-Sustain VT	A run of PVCs < the V-Tach run limit and ventricular heart rate > the V-Tach HR limit			x
** Vent Rhythm	A dominant rhythm of adjacent Vs > the vent rhythm limit and ventricular heart rate < the V-Tach HR limit			x
** Run PVCs High	A run of > 2 PVCs			x
** Pair PVCs	Two ventricular beats between two non-ventricular beats			x
** R-on-T PVCs	For HR < 100, a PVC with R-R interval < 1/3 the average interval followed by a compensatory pause of 1.25*(the average R-R interval), or two such Vs without compensatory pause occurring within 5 minutes of each other. (When HR > 100, 1/3 R-R interval is too short for beat detection)			x
** Vent Bigeminy	A dominant rhythm of N, V, N, V (N = supraventricular beat, V=ventricular beat)			x
** Vent Trigeminy	A dominant rhythm of N, N, V, N, N, V (N = supraventricular beat, V = ventricular beat)			x
** PVCs/min High	PVCs detected within a minute > the alarm limit		x	x
** Multiform PVCs	Two different shaped Vs detected, each occurring at least twice within the last 300 beats and at least once within the last 60 beats			x
** Pause	No beat detected for a period > the pause threshold			x
** Missed Beat	No beat detected for > 1.75*(the averaged R-R interval), or no beat detected for > one second if HR > 120 (For non-paced patients only)			x

Alarm	Description	Arrhythmia Configuration		
		Arrhythmia Off	Basic Arrhythmia	Enhanced Arrhythmia
** Pacer Not Capt	No beat detected for > 1.75*(the averaged R-R interval) with detected pace pulse(s). (For paced patients only)		x	x
**Pacer Not Pacing	No beat and pace pulse detected for > 1.75*(the averaged R-R interval). (For paced patients only)		x	x
** SVT	A run of supraventricular beats > the SVT run limit and heart rate > the SVT HR limit			x
* HR High	Heart rate > the high HR alarm limit		x (see note)	x (see note)
* HR Low	Heart rate < the low HR alarm limit		x (see note)	x (see note)
* AFIB	Atrial fibrillation waveform detected			x
* End AFIB	Atrial fibrillation no longer detected for the configured Afib end delay time			x
** Irregular HR	Consistently irregular rhythm (irregular R-R intervals)			x
* End Irregular HR	Irregular HR no longer detected for the configured irregular HR end delay time			x

Note: **HR High/Low are available only if HR alarms are configured to "yellow", and *HR High/Low are available only if HR alarms are configured to "short yellow".

Using ECG Alarms

ECG alarms can be switched on and off and the high and low alarm limits changed just like other measurement alarms, as described in the "Alarms" chapter. Special alarm features which apply only to ECG are described here.

Extreme Alarm Limits for Heart Rate

The extreme rate alarms, Extreme Tachy and Extreme Brady, generated by the active alarm source, either HR or Pulse, are set in Configuration Mode by adding a set value (the Δ value) to the high and low alarm limits.

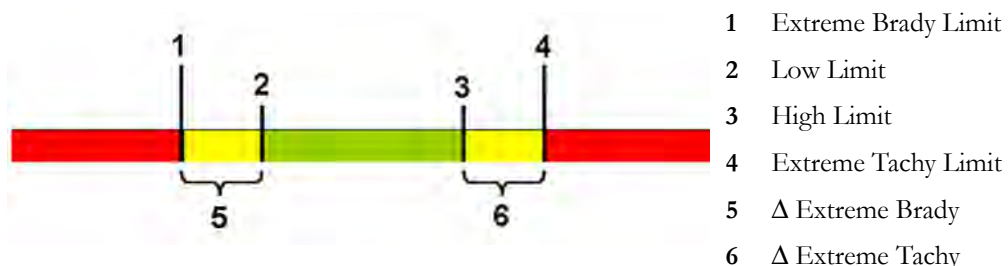

You need to know which value has been configured for your monitor. Changing the high and low alarm limits automatically changes the extreme alarm limits within the allowed range.

To see the extreme rate alarms set for your monitor, in the **Setup ECG** menu, see the menu items **Δ ExtrTachy** and **Δ ExtrBrady**.

ECG Alarms Off Disabled

Be aware that your hospital department may have decided to disable the **Alarms Off** setting for ECG in the monitor's Configuration Mode. In this case, HR alarms cannot be switched off in Monitoring Mode. If you try to switch off the HR alarms, you will see the message **To activate enter Config and enable Alarms Off**.

HR Alarms When Arrhythmia Analysis is Switched Off

When arrhythmia analysis is switched off, only these HR-related alarms will be detected:

- the asystole alarm
- the ventricular fibrillation/tachycardia alarm
- the extreme tachycardia and extreme bradycardia alarms
- the high heart rate and low heart rate alarms.

Enhanced Asystole Detection

In order to improve alarming on asystole under certain conditions, you can set **Asystole Detect** in Configuration Mode to **Enhanced**. In enhanced mode an asystole alarm will be suppressed for up to five seconds if a valid beat-to-beat Pulse is detected from a Pressure.

ECG Safety Information

CAUTION

Interference from instruments near the patient and ESU interference can cause problems with the ECG wave. See the monitor specifications for more information.

WARNING

Defibrillation and Electrosurgery:

Do not touch the patient, or table, or instruments, during defibrillation.

After defibrillation, the screen display recovers within 10 seconds if the correct electrodes are used and applied in accordance with the manufacturers instructions.

ECG cables can be damaged when connected to a patient during defibrillation. Check cables for functionality before using them again.

According to AAMI specifications the peak of the synchronized defibrillator discharge should be delivered within 60 ms of the peak of the R wave. The signal at the ECG output on the IntelliVue patient monitors is delayed by a maximum of 30 ms. Your biomedical engineer should verify that your ECG/Defibrillator combination does not exceed the recommended maximum delay of 60 ms.

When using electrosurgical (ES) equipment, never place ECG electrodes near to the grounding plate of the ES device, as this can cause a lot of interference on the ECG signal.

General:

When you are connecting the electrodes or the patient cable, make sure that the connectors never come into contact with other conductive parts, or with earth. In particular, make sure that all of the ECG electrodes are attached to the patient, to prevent them from contacting conductive parts or earth.

During surgery:

Use the appropriate orange electrode ECG safety cable, or lead cable with an orange connector, for measuring ECG in the operating room. These cables have extra circuitry to protect the patient from burns during cautery, and they decrease electrical interference. This also reduces the hazard of burns in case of a defective neutral electrode at the HF device. These cables cannot be used for measuring respiration.

Pacemaker failure:

During complete heart block or pacemaker failure to pace/capture, tall P-waves (greater than 1/5 of the average R-wave height) may be erroneously counted by the monitor, resulting in missed detection of cardiac arrest.

Patients exhibiting intrinsic rhythm:

When monitoring paced patients who exhibit only intrinsic rhythm, the monitor may erroneously count pace pulses as QRS complexes when the algorithm first encounters them, resulting in missed detection of cardiac arrest.

The risk of missing cardiac arrest may be reduced by monitoring these patients with low heart rate limit at or slightly above the basic/demand pacemaker rate. A low heart rate alarm alerts you when the patient's heart rate drops to a level where pacing is needed. Proper detection and classification of the paced rhythm can then be determined.

Filtered ECG signal from external instruments:

Instruments such as defibrillators or telemetry units produce a filtered ECG signal. When this signal is used as an input to the bedside monitor, it is filtered again. If this twice-filtered signal is passed to the arrhythmia algorithm, it may cause the algorithm to fail to detect pace pulses, pacemaker non-capture, or asystole, thus compromising paced patient monitoring performance.

External pacing electrodes:

When a pacemaker with external pacing electrodes is being used on a patient, arrhythmia monitoring is severely compromised due to the high energy level in the pacer pulse. This may result in the arrhythmia algorithm's failure to detect pacemaker noncapture or asystole.

Fusion beat pacemakers:

Pacemakers that create fusion beats (pace pulse on top of the QRS complex) cannot be detected by the monitor's QRS detector.

Rate adaptive pacemakers:

Implanted pacemakers which can adapt to the Minute Ventilation rate may occasionally react on the Impedance measurement used by patient monitors for the determination of the Resp value and execute pacing with the maximum programmed rate. Switching off the Resp measurement can prevent this.

Line isolation monitor transients:

When electrodes or lead wires are loose or detached, the monitor becomes susceptible to switching transients from some types of line isolation monitors. Line isolation monitor transients may resemble actual cardiac waveforms and thus inhibit heart rate alarms. To minimize the chance of this occurring, always adhere to the instructions for skin preparation and electrode placement given in this chapter.

About Arrhythmia Monitoring

Arrhythmia analysis provides information on your patient's condition, including heart rate, PVC rate, rhythm, and ectopics. The monitor uses the user-selected primary and secondary ECG leads for single-lead or multi-lead arrhythmia analysis. During arrhythmia analysis, the monitor continuously

- optimizes ECG signal quality. This is important for arrhythmia analysis. The monitor continuously filters the ECG signal to remove baseline wander, muscle artifact, and signal irregularities. Also, if the Patient Paced status is set to **Yes**, pace pulses are filtered out to avoid processing them as QRS beats.
- detects beats, for example, QRS complexes, identifying them for further analysis.
- measures signal features such as R-wave height, width, and timing.
- creates beat templates, and classifies and labels beats to aid in rhythm analysis and alarm detection.
- examines the ECG signal for ventricular fibrillation, asystole, and noise.

Arrhythmia Options

Your monitor has either the basic or the enhanced arrhythmia option. Both options provide rhythm and ectopic status messages and beat labeling. The number of rhythms being classified, events being detected, and alarms generated differs according to the option. The alarms available with the different options are listed in the section “ECG and Arrhythmia Alarm Overview” on page 149, the rhythm and ectopic messages detected are listed in “Arrhythmia Status Messages” on page 157.

Where Can I Find More Information?

See the Application Notes on ST and Arrhythmia supplied on your documentation DVD for detailed information on the arrhythmia algorithm and its clinical application.

Switching Arrhythmia Analysis On and Off

- 1 In the **Setup Arrhy** menu, select **Arrhythmia** to toggle between **On** and **Off**.
- 2 Select the **Confirm** pop-up key which appears at the bottom of the screen.

Be aware that when arrhythmia analysis is switched off,

- the message **Arrhythmia Off** appears beside the ECG wave, if configured to do so
- only the HR-related alarms are detected (the asystole alarm, the ventricular fibrillation/tachycardia alarm, the extreme tachycardia and extreme bradycardia alarms, the high heart rate and low heart rate alarms)
- HR High and HR Low alarms behave like normal yellow alarms, no timeout periods are active.

Choosing an ECG Lead for Arrhythmia Monitoring

It is important to select a suitable lead for arrhythmia monitoring.

Guidelines for non-paced patients are:

- QRS complex should be tall and narrow (recommended amplitude > 0.5 mV)
- R-Wave should be above or below the baseline (but not bi-phasic)
- T-wave should be smaller than 1/3 R-wave height
- the P-wave should be smaller than 1/5 R-wave height.

For paced patients, in addition to the above, the pace pulse should be:

- not wider than the normal QRS
- the QRS complexes should be at least twice the height of pace pulses
- large enough to be detected, with no re-polarization.

To prevent detection of P-waves or baseline noises as QRS complexes, the minimum detection level for QRS complexes is set at 0.15 mV, according to AAMI-EC 13 specifications. Adjusting the ECG wave size on the monitor display (gain adjustment) does not affect the ECG signal which is used for arrhythmia analysis. If the ECG signal is too small, you may get false alarms for pause or asystole.

Atrial Fibrillation Alarm

The monitor performs atrial fibrillation analysis using information about the RR irregularity, PR interval variability and P wave variability.

In order to generate an Afib alarm the following criteria must be detected for 1 minute:

- normal beat RR intervals must be irregular
- PR interval deviation must be large
- P-wave region must not match well

Atrial fibrillation analysis is only available for adult patients and atrial fibrillation detection cannot be performed on PVCs or Paced beats.

An **** End AFIB** alarm will occur when no atrial fibrillation waveform was detected for a configured delay time.

Since most atrial flutters have regular RR intervals, they cannot be detected by the atrial fibrillation algorithm.

An **** AFIB** can be falsely detected in the presence of:

- sinus arrhythmia,
- muscle noise, or
- electrode motion artifact.

If you also have monitors with earlier software revisions, the **** AFIB** and **** End AFIB** alarms will not be generated after a transfer to one of these monitors. Always leave the Irregular HR alarm switched on, so that this alarm can be generated in such situations.

See the Application Note on Arrhythmia/ST supplied on your documentation DVD for detailed information on the arrhythmia algorithm and ECG analysis.

Aberrantly-Conducted Beats

As P-waves are not analyzed, it is difficult and sometimes impossible for the monitor to distinguish between an aberrantly-conducted supraventricular beat and a ventricular beat. If the aberrant beat resembles a ventricular beat, it is classified as ventricular. You should always select a lead where the aberrantly-conducted beats have an R-wave that is as narrow as possible to minimize incorrect calls. Ventricular beats should look different from these 'normal beats'. Instead of trying to select two leads with a narrow R-wave, it may be easier to just select one lead and use single lead arrhythmia monitoring. Extra vigilance is required by the clinician for this type of patient.

Intermittent Bundle Branch Block

Bundle branch and the other fascicular blocks create a challenge for the arrhythmia algorithm. If the QRS during the block changes considerably from the learned normal, the blocked beat may be incorrectly classified as ventricular, causing false PVC alarms. You should always select a lead where the bundle branch block beats have an R-wave that is as narrow as possible to minimize incorrect calls. Ventricular beats should look different from these 'normal beats'. Instead of trying to select two leads with a narrow R-wave, it may be easier to just select one lead and use single lead arrhythmia monitoring. Extra vigilance is required by the clinician for this type of patient.

Understanding the Arrhythmia Display

Your monitor screen may look slightly different from the illustration.

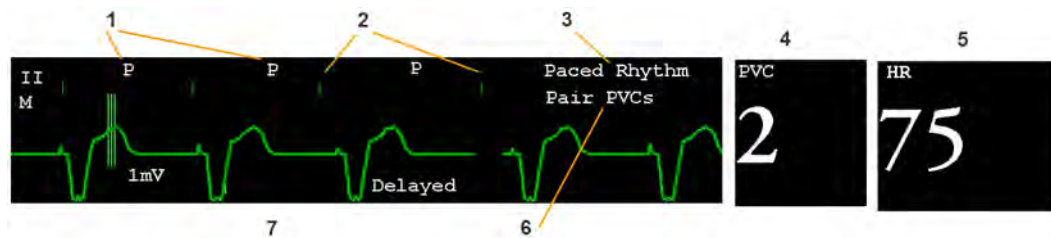

- 1 Beat label
- 2 Pace pulse marks
- 3 Rhythm status message
- 4 PVC Numeric
- 5 HR Numeric
- 6 Ectopic status message
- 7 Delayed arrhythmia wave

Viewing Arrhythmia Waves

To review arrhythmia beat labels, in the **Setup Arrhy** menu, select **Annotate Arrhy**.

The wave showing the primary ECG lead will be delayed by six seconds and shown on a gray background. Beat labels will be annotated above the ECG wave and **Delayed** will be written beside it.

To return to the normal ECG primary lead display, select **Annotate Arrhy** again.

Arrhythmia Beat Labels

Arrhythmia beat labels tell you how the monitor is classifying beats.

- N** = Normal
- V** = Ventricular Ectopic
- S** = Supra-ventricular Premature
- P** = Paced
- ' = Pacer spike
- " = Biventricular Pacer Spike
- L** = Learning patient's ECG
- A** = Artifact (noisy episode)
- ? = Insufficient information to classify beats
- I** = Inoperative condition (e.g., LEADS OFF)
- M** = Pause or missed beat

Arrhythmia Status Messages

The monitor displays two types of status messages:

- Rhythm Status Messages -- to indicate the patient's rhythm.
- Ectopic Status Messages -- to indicate the presence of ectopic beats.

These status messages are shown on the right hand side of the primary ECG wave. They are updated every second, with the exception of the Sinus and Supraventricular (SV) rhythm messages.

The Sinus and SV rhythm messages are updated based on the current heart rate, taking into account the patient category (adult, pediatric, or neonatal). For the message to change from one rhythm status to another, the HR must be in the new range for five beats.

If you have basic arrhythmia capability, you will get only messages for the alarms provided with this level.

Rhythm Status Messages

The label B or E indicates basic (B) or enhanced (E) arrhythmia capability.

Rhythm Status Message	Description	B or E
Asystole	No QRS for 4 consecutive seconds in absence of vent fib or chaotic signal	B, E
Vent Fib/Tach	A fibrillatory wave for 4 consecutive seconds	B, E
VTach	A dominant rhythm of adjacent Vs and a HR > the V-Tach Heart Rate Limit	B, E
Sustained VT	Ventricular tachycardia rhythm for more than 15 seconds	E
Vent Rhythm	A dominant rhythm of adjacent PVCs and a HR ≤ the V-Tach HR Limit	E
Vent Bigeminy	A dominant rhythm of N, V, N, V	E
Vent Trigeminy	A dominant rhythm of N, N, V, N, N, V	E

Rhythm Status Message	Description	B or E
Paced Rhythm	A dominant rhythm of paced beats	B, E
Irregular HR	Consistently irregular rhythm	E
Sinus Brady Sinus Rhythm Sinus Tach	A dominant rhythm of SV beats preceded by P-waves	B, E
SV Brady SV Rhythm SV Tach	A dominant rhythm of SV beats not preceded by P-waves	B, E
Unknown ECG Rhythm	Rhythm cannot be determined	B, E
Learning ECG	Algorithm is learning the ECG beat morphology	B, E
Learning Rhythm	Algorithm is learning the rhythm of the classified beats	B, E
Cannot Analyze ECG	ECG signal is predominantly invalid and therefore cannot be analyzed	B, E

Ectopic Status Messages

The label B or E indicates basic (B) or enhanced (E) arrhythmia capability.

Ectopic Status Message	Explanation	B or E
(No message displayed)	No ectopic activity within the last minute	
Run PVCs	More than 2 consecutive PVCs within the last minute	E
Pair PVCs	Pair PVCs within the last minute	E
Pacer Not Capt	Pause with pace pulse (paced patient only) within the last minute	B, E
PacerNotPacing	Pause without pace pulse (paced patient only) within the last minute	B, E
Pause	No beat detected for 1.75 x average R-R interval for HR <120, or No beat for 1 second with HR >120 (non-paced patient only), or No beat detected for more than the set pause threshold.	E
R-on-T PVCs	R-ON-T detected within the last minute	E
Multiform PVCs	Multiform PVCs detected within the last minute	E
Frequent SVPBs	SVPB count within last minute is greater than 5	E
SVPBs	1-5 SVPBs in the last minute with a sinus rhythm and no Vs	E
SV Beats	SV count within last minute and rhythm status is paced	B, E
Paced Beats	Paced beat count within last minute and rhythm status is not paced	B, E

Arrhythmia Relearning

During a learning phase:

- Alarm timeout periods are cleared
- Stored arrhythmia templates are cleared
- Asystole, Vfib, and HR alarms (when there are enough beats to compute the HR) are active. No other alarms are active.

Initiating Arrhythmia Relearning Manually

To initiate relearning manually, in the **Setup Arrhy** menu, select **Relearn Arrhy**.

- While the monitor is learning, the delayed arrhythmia wave displays the beat label **L** and the rhythm status message **Learning ECG**.
- Next, the monitor determines the dominant rhythm. The beats are labeled **N**, and the rhythm status message changes to **Learning Rhythm**.

After relearning is complete, you should check the delayed arrhythmia wave to ensure that the algorithm is labeling the beats correctly.

If beats are still not classified correctly, check that the ECG is optimized for arrhythmia monitoring. You may need to select a different lead or change the electrodes or electrode positions if there is excessive noise, unstable voltage, low amplitude, or large P- or T-waves.

Automatic Arrhythmia Relearn

Arrhythmia relearning is initiated automatically whenever:

- ECG monitoring is switched on
- The ECG Lead or Lead Label of the primary/secondary lead is changed manually, or when fallback occurs
- A Leads Off INOP condition (that has been active for > 60 seconds) ends.

If you are monitoring multi-lead arrhythmia and there is a change in one lead only, relearning happens only in the affected lead. During this learning phase, the system will continue monitoring using the other lead. Therefore, the delayed arrhythmia wave is not labeled **L** and there is no **Learning ECG** rhythm status message. In addition, alarm timeout periods are maintained, stored arrhythmia templates are maintained for the operative lead, and all alarms switched on are active.

Arrhythmia Relearn and Lead Fallback

Lead fallback triggers an automatic arrhythmia relearn.

WARNING

If arrhythmia learning takes place during ventricular rhythm, the ectopics may be incorrectly learned as the normal QRS complex. This may result in missed detection of subsequent events of V-Tach and V-Fib.

For this reason you should:

- take care to initiate arrhythmia relearning only during periods of predominantly normal rhythm and when the ECG signal is relatively noise-free
 - be aware that arrhythmia relearning can happen automatically
 - respond to any INOP messages (for example, if you are prompted to reconnect electrodes)
 - be aware that a disconnected EASI electrode triggers an arrhythmia relearn on all leads
 - always ensure that the arrhythmia algorithm is labeling beats correctly.
-

Arrhythmia Alarms

Arrhythmia alarms can be switched on and off and the alarm settings changed just like other measurement alarms, as described in the Alarms section. Special alarm features which apply only to arrhythmia are described here.

The different alarms detected and generated by the monitor depend on the level of arrhythmia analysis that is enabled. For a complete list of arrhythmia alarms and INOPs, see the “Alarms” chapter.

The monitor detects arrhythmia alarm conditions by comparing ECG data to a set of pre-defined criteria. An alarm can be triggered by a rate exceeding a threshold (for example, HR >xx), an abnormal rhythm (for example, Ventricular Bigeminy), or an ectopic event (for example, Pair PVCs).

Yellow Arrhythmia Alarms

Yellow arrhythmia alarms are short yellow alarms specific to arrhythmia-related patient conditions. The heart rate alarms (High HR and Low HR) can be configured as short yellow or standard yellow alarms. When they are standard yellow alarms they exist independently of the other arrhythmia alarms and no timeout periods apply.

WARNING

When arrhythmia analysis is on, all yellow ECG and arrhythmia alarms are short yellow alarms (one-star). This means that the yellow alarm lamp and the tones are active for six seconds only, after which the blinking numeric and the alarm message remain for up to three minutes. The only exception to this are the HR High and Low alarms which can be configured as standard yellow alarms. Red alarms behave as usual.

Arrhythmia Alarms and Latching

When using arrhythmia analysis, **Visual Latching** and **Audible Latching** should be on for red alarms, or at least **Visual Latching** should be on. Because of the transient nature of arrhythmia alarms, many arrhythmia conditions may go unnoticed if alarm latching is off. This setting can only be changed in Configuration Mode.

Switching Individual Arrhythmia Alarms On and Off

Some arrhythmia alarms can be individually switched on or off:

Non-Sustain, Vent Rhythm, Run PVCs, Pair PVCs, R-on-T PVCs, V.Bigeminy, V.Trigeminy, Multif.PVCs, Pacer n.Cap, Pacer n.Pac, Pause, SVT, IrregularHR, Missed Beat, PVCs/min and Afib.

To switch individual alarms on or off, in the **Setup Arrhy** menu, select the alarm from the list to switch between **On** and **Off**. Depending on your configuration, some alarms may not be available in the list and cannot be switched on or off here.

The monitor displays the INOP message **Some ECG AlarmsOff**, if configured, when more alarms are switched off than configured in your active profile.

Switching All Yellow Arrhythmia Alarms On or Off

All yellow arrhythmia alarms can be switched on and off together. To do this,

- In the **Setup Arrhy** menu, select **All Yellow Off** or **All Yellow On**.

Adjusting the Arrhythmia Alarm Limits

Some arrhythmia alarms have limits which can be individually adjusted:

VTach HR, VTach Run, PVCs/min, Vent Rhythm, SVT HR, SVT Run, Asystole Thresh., Pause Threshold, Afib/IHR End Dly.

- 1 To adjust alarm limits, in the **Setup Arrhy** menu, select the alarm to be adjusted.
- 2 Select the appropriate setting from the pop-up list.

Arrhythmia Alarm Timeout Periods

Normally, an arrhythmia alarm is announced when an alarm condition is detected. However, there are certain situations that can inhibit the audible and visible indications of the alarm even though the alarm condition was detected. These include:

- if a more serious alarm condition is active in the same chain
- if a timeout period is in effect for a particular alarm
- if a timeout period is in effect for a higher alarm in that chain.

See “Arrhythmia Alarm Chaining” on page 162 for more details on alarm chains.

What is a Timeout Period?

Timeout periods are automatically started when a yellow arrhythmia alarm is detected. During this period, the same alarm condition will not generate another alarm. Alarm conditions further down the same arrhythmia alarm chain will also not generate an alarm, but alarms further up the chain will: see “Arrhythmia Alarm Chaining” on page 162.

To view the timeout period configured for your monitor, in the **Setup Arrhy** menu, see the menu items **TimeOut 1st** and **TimeOut 2nd**.

This setting can only be changed in Configuration Mode.

**** AFIB** and **** Irregular HR** alarms do not have a timeout period. These alarms can be generated immediately after the corresponding end alarm was generated.

When **** HR High** and **** HR Low** alarms are configured as standard yellow alarms, they do not have a timeout period.

Resetting the Timeout Period

To reset the timeout period, either

- select the **Alarms Off** or **Pause Alarms** permanent key and then reselect it, or
- select **Reset Alarming** in the **Review Alarms** window or the **Alarm Messages** window.

How are Yellow Arrhythmia Alarms Indicated?

When a yellow arrhythmia alarm is generated, it triggers visual and audible indicators. Yellow arrhythmia alarms are always set to latch visually for three minutes except HR High/Low alarms, if configured to standard yellow. Depending on the alarm condition, audible and visual alarm indicators will appear as follows:

Alarm Condition	Example	Short yellow alarm tone sounds	Alarm message displayed
Single alarm instance	Non-sustained V-tach	when alarm condition is initially detected	for 3 minutes (latching time)
Continuous alarm condition	PVCs/min HIGH	when alarm condition is initially detected and - as an alarm reminder - every time the configured timeout period has expired	until the alarm condition stops, plus a maximum of three minutes latching time
Same intermittent alarm condition	Pair of PVCs	each time the alarm condition is detected, provided that the configured timeout period has expired	

If you silence a yellow arrhythmia alarm and the alarm condition still exists, the visual indicators continue until the condition stops. You will get an alarm reminder every time the configured timeout period has expired.

If you silence a yellow arrhythmia alarm and the alarm condition has stopped, the visual indicators are immediately cleared. Silencing an alarm does not reset its timeout period, so you will not get a realarm for the same condition or lower on the chain until the timeout expires.

Arrhythmia Alarm Chaining

When arrhythmia analysis is switched on, multiple alarm conditions may be present. Announcing all of the detected alarm conditions would be confusing, and might hide a more serious condition. For this reason, arrhythmia alarms are prioritized in three alarm "chains": PVC Alarms; Beat Detection Alarms, and Rate Alarms.

Only the highest priority alarm condition in each chain is announced. Lower priority alarms in the same chain will not be announced while an alarm is active or during the configured timeout period.

If alarm conditions of equal severity from different chains are detected, the alarm condition that occurred most recently is announced.

See “ECG and Arrhythmia Alarm Overview” on page 149 for information on which alarms are included in the different arrhythmia options. See “Arrhythmia Alarm Timeout Periods” on page 161 for an explanation of how alarm timeouts work.

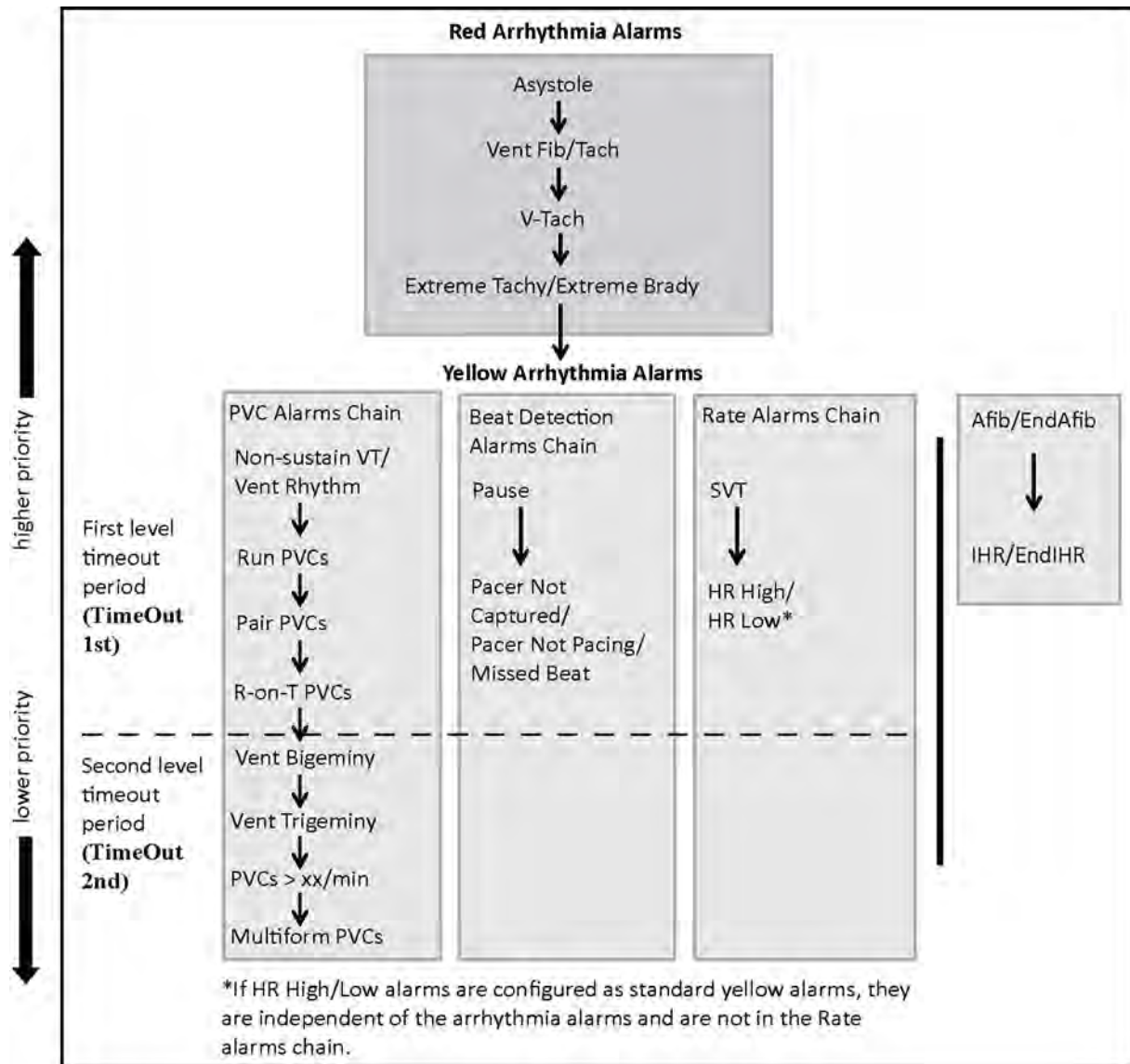

Examples of Alarm Chaining Logic

- If there is an active Vent Bigeminy alarm, a PVCs > xx/min will not be triggered because it is lower on the same chain. However, a high HR alarm will become active because it is on a different chain.
- Higher priority alarms supersede previous alarms. For example, if a Vent Trigeminy alarm is active and a Pair PVCs occurs, the Pair alarm will be activated.

Understanding PVC-Related Alarms

PVC-related alarms are detected on the basis of the current ventricular heart rate and the number of consecutive PVCs counted (referred to as PVC Runs).

As an example, this diagram illustrates the conditions under which PVC alarms would be generated if the Vent Rhythm Run limit is set to 12, the V-Tach Run Limit is set to 8, and the V-Tach HR Limit is set to 100.

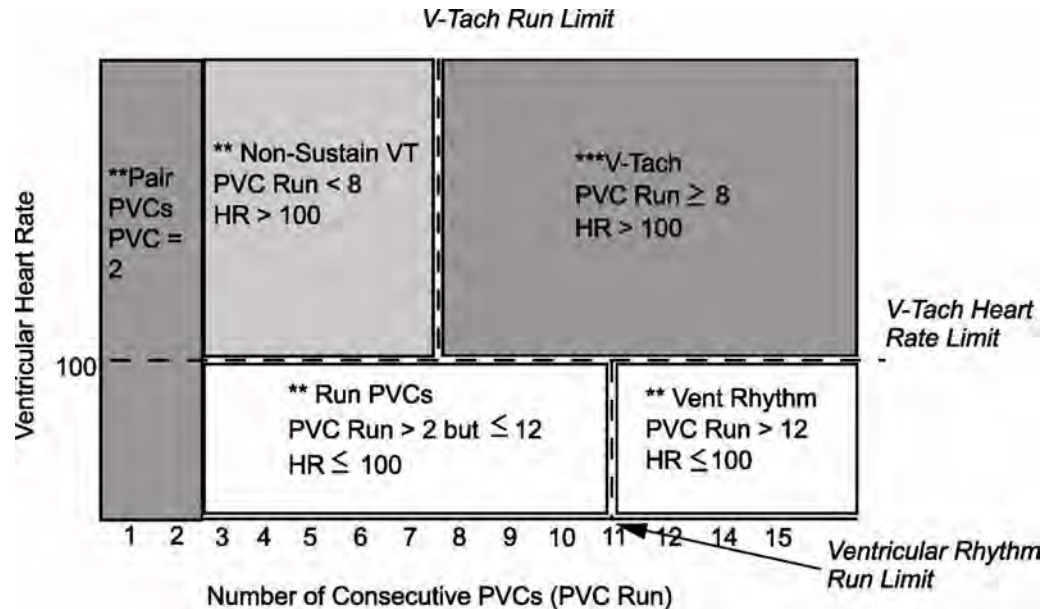

You will see that

- if both the V-Tach Heart Rate Limit and the V-Tach Run Limit are exceeded, a red V-Tach alarm is generated
- if the ventricular heart rate exceeds the V-Tach Heart Rate Limit but not the V-Tach Run Limit, a yellow Non-Sustain VT alarm is generated.

About ST Monitoring

The monitor performs ST segment analysis on normal and atrially paced beats and calculates ST segment elevations and depressions. This information can be displayed in the form of ST numerics and snippets on the monitor.

The monitor also performs ST Elevation (STE) analysis using automated ISO and J point determination and measuring the ST segment directly at the J point (J +0). This is based on the recommendations for measuring ST Elevation published by the American Heart Association, the American College of Cardiology and the European Society of Cardiology.

All available leads can be monitored continuously. The ECG waveform does not need to be displayed on the monitor for ST Segment analysis.

ST analysis is always performed using a dedicated filter which ensures diagnostic quality. If you are monitoring ECG using an ECG filter mode other than Diagnostic, the ST segment of the ECG wave may look different from the ST segment of the ST snippet for the same wave. For diagnostic evaluation of the ST segment, always switch to Diagnostic filter mode or use the ST snippet.

WARNING

Some clinical conditions may make it difficult to achieve reliable ST monitoring, for example:

- if you are unable to get a lead that is not noisy
- if arrhythmias such as atrial fib/flutter are present, which may cause an irregular baseline
- if the patient is continuously ventricularly paced
- if the patient has left bundle branch block.

You should consider switching ST monitoring off if these conditions are present.

This monitor provides ST level change information; the clinical significance of the ST level change information should be determined by a physician.

ST segment monitoring is intended for use with adult patients only and is not clinically validated for use with neonatal and pediatric patients. For this reason, the recommended - and default - setting for ST monitoring in neonatal and pediatric modes is **ST Analysis: Off**.

Switching ST or STE On and Off

ST and STE analysis can be switched on and off independently.

To switch all ST monitoring on or off, in the **Setup ST Analysis** menu, select **ST Analysis** to switch between **On** and **Off**.

To switch all STE monitoring on or off, in the **Setup ST Elevation** menu, select **STE** to switch between **On** and **Off**.

Selecting Leads for ST Analysis

You select which leads to use for ST analysis in the **Setup ST Analysis** menu.

To see the current list of leads selected for ST analysis:

- 1 Enter the **Setup ST Analysis** menu.
- 2 Select **Setup ST Leads**. This opens the **Setup ST Leads** pop-up window. Leads chosen for ST monitoring are listed here. There are two pop-up keys at the bottom of the screen, **Add** and **Delete**. If all leads are already selected, the **Add** pop-up key is disabled.

To choose a lead for ST monitoring:

- 1 Select the **Add** key at the bottom of the **Setup ST Leads** window. This opens the **Choices** pop-up window.
- 2 Choose a lead from the list for ST monitoring. This closes the **Choices** window and adds the selected lead to the list of chosen leads.

To disable ST monitoring for a lead:

- 1 Choose a lead from the list in the **Setup ST Leads** window.
- 2 Select the **Delete** key. This removes this lead from the list.

NOTE

The order in which ST leads are listed in the **Setup ST Leads** menu determines the order in which ST leads are displayed on the monitor screen.

To change the order in which ST leads are displayed,

- 1 In the **Setup ST Leads** menu, choose a lead from the list.
- 2 Select the **Sort Up** or **Sort Down** key to move the lead up or down in the list.

Understanding the ST Display

Your monitor screen may be configured to look slightly different from the illustrations.

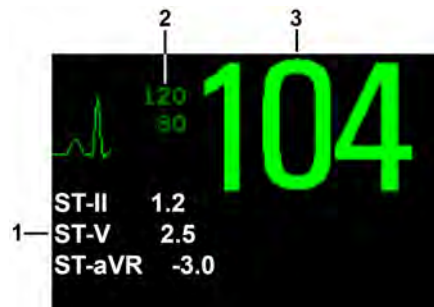

- 1 ST numerics
- 2 Current HR alarm limits
- 3 Current heart rate

ST Numerics

Up to 12 ST numerics plus the ST index can be displayed on the monitor screen. They can be configured to show beside the measurement numerics, beside the ECG wave, or beside the ST snippet.

A positive ST value indicates ST segment elevation; a negative value indicates depression.

ST numerics are displayed in the order in which you select ST leads for analysis. If there is additional space in the field assigned to ST numerics, the monitor will display extra numerics in the order in which they appear in the list in **Setup ST Leads**, in the **Setup ST Analysis** menu. Any ST leads switched on for analysis that do not fit in the assigned numerics field are shown in succession in place of the last ST numeric.

ST Index

The ST index numeric (**STindx**) is the sum of the absolute values for the ST leads V2, V5, aVF.

Because it is based on absolute values, it is always a positive number. If you haven't selected one of the leads V2, V5, and aVF for ST analysis, the ST index numeric will display a question mark "?".

To switch the ST index numeric on or off for display, in the **Setup ST Analysis** menu, select **ST-Index** to toggle between **On** and **Off**.

ST Snippets

ST snippets show a one second wave segment for each measured ST lead. The most recent snippet is drawn in the same color as the ECG wave, usually green, superimposed over the stored baseline snippet, drawn in a different color. The comparison shows any deviation in the measurement since the baseline snippet was stored, for example as a result of a procedure carried out on the patient. The information is updated once per minute.

If you do not see ST snippets on the Screen, select the Screen name in the Monitor Info Line and select a Screen configured to show snippets from the pop-up list of available Screens.

ST View Window

The **ST View** Window shows a current ST snippet and numeric with a baseline snippet and numeric. The two snippets are in different colors, so that you can differentiate between them easily and see at a glance which numerics belong to which snippet. In the upper left corner the current lead and the ISO/J-Point mode for the current snippet and the baseline snippet is shown. On the right side all available ST numerics are shown. The date and time of the baseline snippet is shown at the bottom of the window.

The **ST View** Window opens with the ST pop-up keys **Current / Baseline / Overlap** (to select viewing mode), **Show Points / Hide Points**, **Update Baseline**, **Record ST**, **STE View**, **Adjust ST Points**, **ST Map**, **Setup ST** and arrow keys for scrolling through the available leads.

To view the **ST View** window, select any snippet on the Screen.

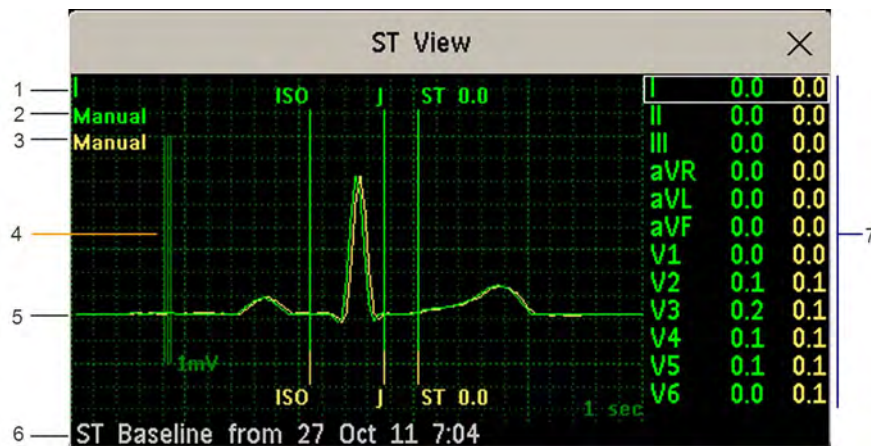

- 1 Current Lead
- 2 ISO/J-point mode for current snippet
- 3 ISO/J-point mode for baseline snippet
- 4 1 mV calibration bar
- 5 Current ST snippet and ST baseline snippet overlapped
- 6 Timestamp of most recently stored baseline snippet
- 7 All available ST numerics for current snippet and baseline snippet

The ST point, J-point and ISO point can be hidden using the **Hide Points** pop-up key.

STE View Window

The **STE View** window shows a current ST snippet and STE numeric with an ST baseline snippet. The two snippets are in different colors, so that you can differentiate between them easily. In the upper left corner the current lead is shown. On the right side all available STE numerics are shown. The date and time of the ST baseline snippet is shown at the bottom of the window.

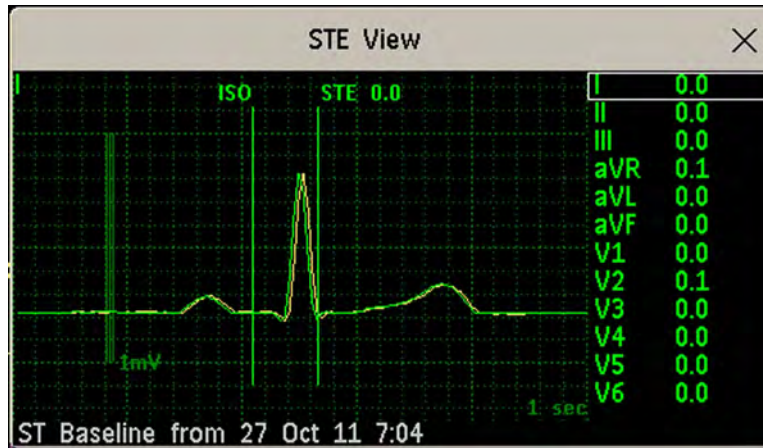

The **STE View** window opens with the pop-up keys **Current / Baseline / Overlap** (to select viewing mode), **Show Points/Hide Points**, **Record STE**, **ST View**, **ST Map**, **Setup ST** and arrow keys for scrolling through the available leads.

The ST point, J-point and ISO point can be hidden using the **Hide Points** pop-up key.

Updating ST Baseline Snippets

ST analysis requires valid samples to measure and store a snippet. ST Snippets and ST values are updated every minute. If there is artifact in the signal, it may take longer for an ST snippet and an ST value to appear.

The first baseline is stored automatically after ST monitoring is started, or when a new patient is admitted.

To update ST baselines,

- 1 Select an ST snippet to open the **ST View** window.
- 2 In the **ST View** window, select **Update Baseline** to store all current snippets as baselines. This deletes all previously-stored baselines.

An ST baseline copy is also stored in the MMS, for transport purposes.

Recording ST Segments

To record all currently available ST snippets and baselines, in the **ST View** window, select the pop-up key **Record ST**.

About the ST Measurement Points

The ST value for each beat complex is the vertical difference between the ISO point and the ST point, as shown in the diagram below.

The isoelectric (ISO) point provides the baseline, the ST point is at the midpoint of the ST segment. The J point is where the QRS complex changes its slope; as it is a fixed distance away from the ST point, it can be useful to help you position the ST point correctly.

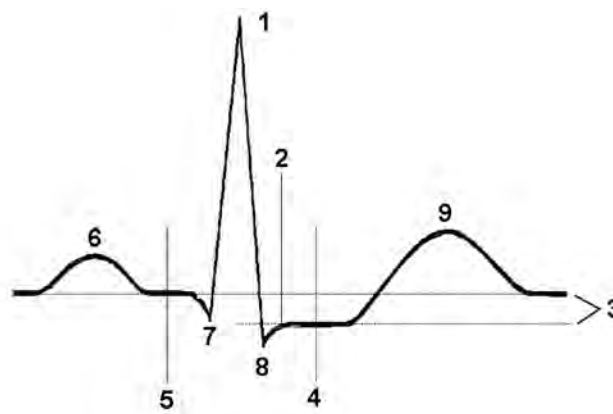

- 1 R-wave peak at 0 msec
- 2 J point, for example, 48 msec
- 3 Difference = ST value
- 4 ST measurement point, for example, J + 60 msec
- 5 Isoelectric point set to -80 msec
- 6 P
- 7 Q
- 8 S
- 9 T

CAUTION

If using ST analysis, the ST measurement points need to be adjusted when you start monitoring, and if the patient's heart rate or ECG morphology changes significantly, as this may affect the size of the QT interval and thus the placement of the ST point. Artifactual ST segment depression or elevation may occur if the isoelectric point or the ST point is incorrectly set.

Always ensure that ST measurement points are appropriate for your patient.

Setting ISO and J-Point Detection Mode

There are two modes for ISO and J-point detection: **Auto** and **Manual**. In **Manual** mode you can set the measurement points yourself. In **Auto** mode the measurement points will be determined automatically.

To set the detection mode, in the **Setup ST Analysis** window,

- 1 Select **ISO/J Point**.
- 2 Select **Auto** or **Manual** mode.

Adjusting ST Measurement Points

If the ISO and J-point detection mode is set to **Manual**, all three measurement points can be set. In **Auto** mode, only the ST point can be changed.

To adjust the ST measurement points, in the **Setup ST Analysis** menu,

- 1 Select **Adjust ST Points** to open the **Adjust ST Points** window.
Alternatively, you can use the **Adjust ST points** pop-up key in the **ST View** window.
- 2 Select a suitable ECG lead for ST measurement, with a visible J-point and a visible P wave. Use the up and down arrow keys to scroll through the ST snippets for the other ECG leads.

- Use the **Select Point** pop-up key to scroll through the points and activate the point you need to adjust, then use the left and right arrow keys to move the measurement point. Each point is highlighted while active.

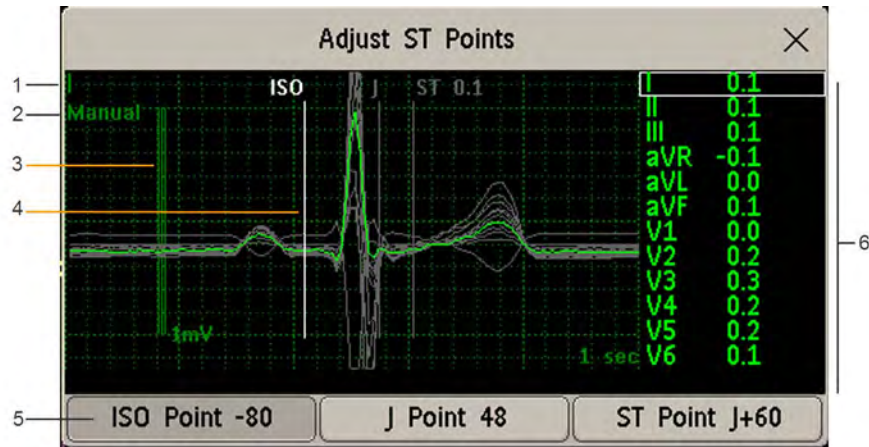

- ST label
- Current ISO/J-point detection mode
- 1 mV calibration bar
- Cursor for adjusting ISO points
- Highlighted ISO point
- All available ST numerics for current snippet

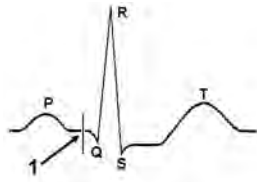

The ISO-point cursor (1) positions the isoelectric point relative to the R-wave peak. The relation is shown beside the ISO-point in milliseconds. Position the ISO-point in the middle of the flattest part of the baseline (between the P and Q waves or in front of the P wave).

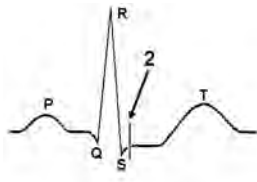

The J-point cursor (2) positions the J-point relative to the R-wave peak. It helps you to correctly position the ST-point. Position the J-point at the end of the QRS complex and the beginning of the ST segment.

The J-point cursor is not available if your monitor is configured to let you set the ST point directly.

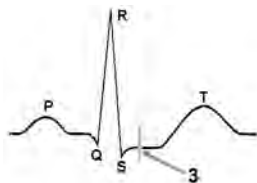

To position the ST-point (3) relative to the J-point:

select either **J+60** or **J+80**. Select **J Point** and use the arrow keys to move the J-Point and position the ST-point at the midpoint of the ST segment.

To position the ST-point directly:

select **ST Point** and use the left and right arrow keys to position the ST point at the midpoint of the ST segment.

- 4 Select the **Apply Changes** pop-up key to activate the new ST measurement points and recalculate all ST values.

The most recent ST Points adjustment time is displayed in the **Adjust ST Points** window. This information is cleared when a patient is discharged or when a new Profile is loaded into the monitor.

- 5 To update the ST snippet shown in the **Adjust ST Points** window, select the **Update** pop-up key.

ST Alarms

ST alarms are yellow alarms. Each ST lead has its own alarm limit. ST alarms are triggered when an ST value exceeds its alarm limit for more than one minute. Switching ST alarms off switches off alarms for all ST leads.

If more than one ST measurement is in alarm, the monitor only displays the alarm message of the ST lead which is currently furthest from its set alarm limits.

Changing ST Alarm Limits

The monitor can detect alarms on each ST lead separately, so you can set high and low ST alarm limits individually for each ST lead. When two contiguous leads are available, ST alarms will be generated when ST values of the two contiguous leads are outside the limit. When no contiguous lead is available an ST alarm is generated when the ST value of the single lead is outside the limit.

Set the high and low alarm limits based on your assessment of the patient's clinical condition, unit protocols, physician orders or medication-specified limits. A good guideline is + 1.0 mm or - 1.0 mm from the patients's ST, or follow your hospital protocol.

- 1 In the **Setup ST Analysis** menu, select the alarm to be adjusted.
- 2 Select the appropriate setting.

STE Alarms

The STE alarm is a yellow alarm. It can be switched on and off in the **Setup ST Elevation** menu but the limits can only be changed in Configuration mode. The STE alarm limits are gender specific and can be set individually for limb leads, V2/V3 leads, and V1/V4/V5/V6 leads. The default values, for example on V2 and V3 1.5 mm for females and 2.0 mm for males, are based on the recommendations from the American Heart Association and American College of Cardiology.

The ST Elevation measurements with automated J-point determination generate ST Elevation alarms, in addition to the ST measurements at the user-defined ST point (J+offset), which may be useful for ST depression alarms. When ST and STE analysis are both in use, this may result in redundant alarms for ST elevations. Because of the different measurement points, there may be different values obtained. Thus there could be an ST alarm and an STE alarm but the STE alarm may announce sooner based upon the values obtained.

Viewing ST Maps

The monitor can derive a multi-axis portrait (map) from the ST analysis to help you detect changes in ST values. It displays two planes obtained from a multilead ECG in a multi-axis diagram, where each axis represents a lead. The ST value at the J point is given. The position of the axes within the diagram correspond to the placement of the ECG leads. Each ST value is assigned to either a limb lead, or to a chest lead. Every axis shows the polarity of the lead it represents. By joining adjacent ST values, the monitor obtains the ST map. The contour line, and the map shading, is shown in the same color as the ECG parameter.

Current View

In current view, the monitor displays an ST map that corresponds to the current ST values. Three or more leads per plane are necessary to display a map.

The left of the following diagram shows leads I, II, III, aVR, aVL, and aVF on the limb leads. On the right, the V-leads (V1, V2, V3, V4, V5, and V6) are on the chest leads.

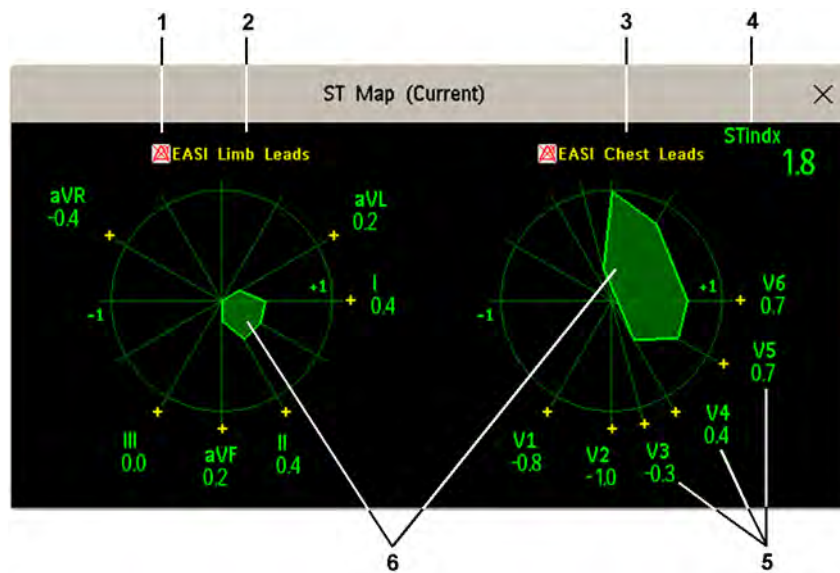

- 1 Alarm status indicator
- 2 **EASI Limb Leads**
- 3 **EASI Chest Leads**
- 4 ST index (for EASI)
- 5 ST label, value and polarity of corresponding lead
- 6 ST map

If an ST lead is switched off, its axis is not shown in the map.



If a lead is in INOP (the value is being measured but is invalid or unavailable because, for example, the corresponding ECG electrode is off), the area formed by the remaining ST leads is left open.



If there is insufficient information (for example, there are less than three chest leads) for a second ST map to be displayed, the currently available ST values are displayed in place of the second ST map.

Trend View

In trend view, you can see up to four trended ST maps, and the current ST map, simultaneously. You can configure the time interval between trended samples. The most recent map is shown in the same color as the parameter itself. Past values change from white through dark gray. In the diagram below, the time interval between trends is one minute. The first trended sample is white and is one minute old. The second trended sample corresponds to the ST values two minutes ago and so forth. The ST values on the diagrams show the current ST values.

If a lead is turned off, its axis is no longer shown. This has no impact on the presentation of trended values that were recorded while the lead was still on.

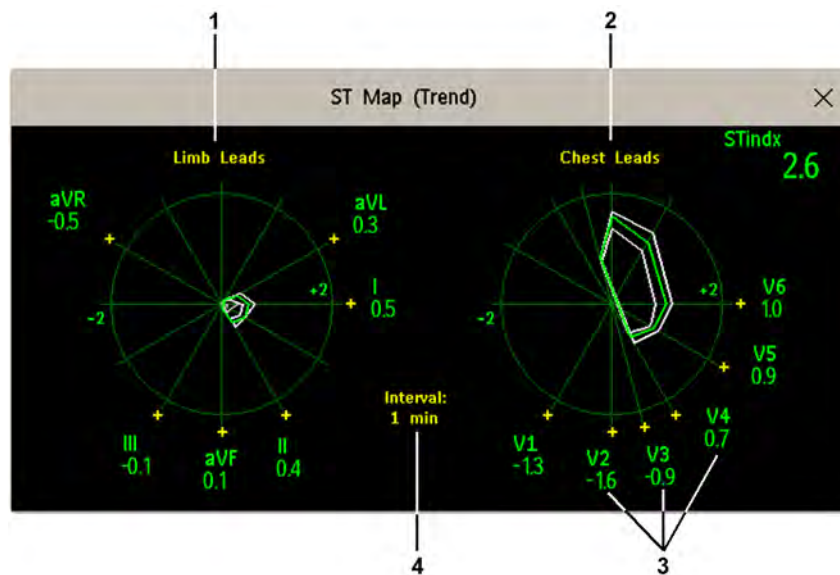

- 1 Limb Leads
- 2 Chest Leads
- 3 current ST values
- 4 trending interval

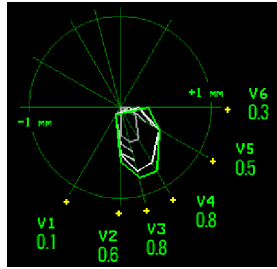

In this diagram, V4 was either temporarily switched off, or in INOP, for around 30 seconds. No data was recorded. Consequently, the affected maps are not closed.

Viewing an ST Map

To display an ST map,

- In the **Main Setup** menu, select **ST Map**.

Working in the ST Map Task Window

You may need to activate the ST map task window to see all the data, and to access the pop-up keys. Select the map view on screen to activate its task window. Once you activate it, you can perform the tasks detailed here.

Switching Between ST Map Views

To switch between views,

- Select **Current View** or **Trend View** to toggle between views.

If your trend view is empty, you need to adjust the priority of this measurement in the trending priority list. See “Trend Priority” on page 316.

Displaying an ST Reference Baseline

You can display an ST reference baseline for the current view, or for the trended view. The baseline is shown in yellow. However, if the ECG color is yellow, the baseline is shown in green. Use this baseline to detect ST changes. The baseline is derived automatically whenever the monitor relearns arrhythmia and also on user request.

Select **Show Baseline/Hide Baseline** to toggle between baseline display on and off.

Updating an ST Map Reference Baseline

To update the baseline,

- In the **Setup ST Analysis** menu, select **ST View** then select **Update Baseline**.

Changing the Scale of the ST Map

To change scale,

- Select **Size Up** or **Size Down** to alter the size at which monitor displays the map.

Changing the Trending Interval

To determine how frequently the monitor displays a trended sample,

- 1 In Trend view, select **Select Interval**.
- 2 Select the required interval from the menu. The interval ranges between 12 seconds to 30 minutes.

Printing an ST Map Report

To print the most recently viewed (current or trend) window,

- 1 Select **Main Setup** then select **Reports**.
- 2 Select **ST Map**.
- 3 Press **Print**.

About QT/QTc Interval Monitoring

The QT interval is defined as the time between the beginning of the Q-wave and the end of the T-wave. It measures the total duration of the depolarization (QRS duration) and repolarization (ST-T) phases of the ventricular action potential. QT interval monitoring can assist in the detection of prolonged QT interval syndrome.

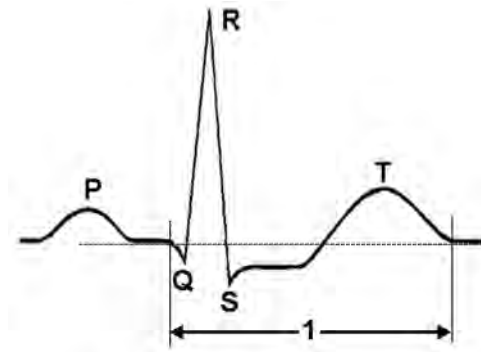

The QT interval (1) has an inverse relationship to heart rate. Faster heart rates shorten the QT interval and slower heart rates prolong the QT interval. Therefore there are several formulas used to correct the QT interval for heart rate. The heart rate corrected QT interval is abbreviated as QTc. The monitor uses as a default the Bazett correction formula and the alternative Fridericia formula can be selected in Configuration Mode.

For QT interval monitoring to be effective, basic or enhanced arrhythmia monitoring should be turned on.

QT Measurement Algorithm

The QT values are updated every five minutes except in the initial phase (first five minutes) where they are updated once per minute. Normal or atrial paced beats and beats with a similar morphology are averaged to form a representative waveform for further processing. Normal beats followed by a premature QRS will be excluded from the measurements to prevent the premature beat from obscuring the end of the T-wave. If the algorithm cannot form a representative waveform, for example because the morphology of the beats is too varied, a **Cannot Analyze QT INOP** will be generated after 10 minutes. This is also the case if normal beats have been falsely labeled so that the algorithm does not have enough valid beats to make QT measurements. No QT value is calculated if the QT-HR is >150 bpm (Adult) or >180 bpm (Pedi/Neo).

Because of the different algorithm approaches, a QT/QTc measurement from a diagnostic 12-lead program may differ from the realtime measurement on the monitor.

Where Can I Find More Information?

See the Application Note on QT/QTc Interval Monitoring and the QT Interval Monitoring Quick Guide supplied on your documentation DVD for detailed information on the QT algorithm and performance.

Indications For Use Of QT Interval Monitoring

Of special concern for QT monitoring is the administration of QT prolonging drugs to patients identified with risk factors for Torsade de Pointe. Females, older patients and patients with bradycardia, impaired left ventricular function (ischemia, left ventricular hypertrophy), hypokalemia and hypomagnesemia are in this increased risk category.

Limitations For Use Of QT Interval Monitoring

Some conditions may make it difficult to achieve reliable QT monitoring, for example:

- the T-wave is very flat
- T-waves are not well defined due to atrial flutter or atrial fibrillation
- the end of the T-wave is difficult to define because of the presence of U-waves
- a high heart rate causes the P-wave to encroach on the end of the previous T-wave
- noise or high QRS morphology variation

For these cases you should select a lead with a good T-wave amplitude and no visible flutter activity, and without a predominant U-wave or P-wave.

Some conditions such as left or right bundle branch block or hypertrophy can lead to a widened QRS complex. If a long QTc is observed you should verify it to ensure that it is not caused by QRS widening.

Because normal beats followed by ventricular beats are not included in the analysis, no QT measurement will be generated in the presence of a bigeminy rhythm.

If the heart rate is extremely high (over 150 bpm for adults and over 180 bpm for pediatrics and neonates) QT will not be measured.

When the heart rate changes, it can take several minutes for the QT interval to stabilize. For reliable QTc calculation it is important to avoid a region where the heart rate is changing.

WARNING

QT/QTc measurements should always be verified by a qualified clinician.

Selecting The QT Leads

For QT Monitoring you can select one of the following three modes:

- All Leads mode - all available leads (I, II, III, V, MCL, V1 - V6) are used to produce a global QT measurement. For EASI lead placement, directly acquired AI, AS and ES leads are used.
- Primary-Lead mode - the primary lead will be used for QT measurement. If the original primary lead becomes unavailable or is changed, QT measurement will continue with the new primary lead.

- Single-Lead mode - a single lead selected from all available leads (except the augmented leads) will be used for QT measurement. QT measurement will stop if the selected lead becomes unavailable.

To select the mode,

- 1 Select the QT numeric to enter the **Setup QT Analysis** window.
- 2 Select QT Lead and select **All, Primary Lead** or one of the available single leads.

When using the All Leads mode, make sure when you compare QT values that they are based on the same set of leads.

Changing the lead(s) used for QT measurements will not cause the baseline to be reset.

QT View

In the **QT View** window you can verify that the QT algorithm detects correct Q and T points.



The current waves are shown in the upper half of the window and the baseline waves in a different color below. The Q and T points are marked with a vertical line. By selecting one of the lead labels at the top of the window you can highlight the corresponding wave; the other waves are shown in gray. The underlined lead labels are the leads used for the QT calculation. By selecting the numeric area you can highlight all underlined leads.

Changing The View To A Single Wave Set

To view one set of waves in a larger scale, you can cycle through the different views,

- 1 Select **Current** view to see the set of current waves.
- 2 Select **Baseline** view to see the set of baseline waves.
- 3 Select **Split** view to return to the combined view with current and baseline waves.

Setting The QT Baseline

In order to quantify changes in the QTc value, you can set a QTc baseline. For example to assess the effect of medication on the QT interval you can set the current value as the baseline before you begin medication. This baseline will then be used to calculate the Δ QTc value.

To set the baseline,

- Select **Set Baseline** and set the value.

If no baseline has been set for this patient, the first five minute value after the start of monitoring is automatically set as baseline. If you set a new baseline the previous baseline is discarded. As the ΔQTc alarm is based on the difference between the baseline and the current value, setting an inappropriate new baseline may prevent a ΔQTc alarm from being generated. Discharging a patient clears the baseline.

Printing The QT Waves

To start a printout,

- Select **Print QT**.

Recording The QT Waves

To start a recording,

- Select **Record QT**.

QT Alarms

There are two QT alarms, QTc high limit alarm and ΔQTc high alarm. The QTc high limit alarm is generated when the QTc value exceeds the set limit for more than 5 minutes. The ΔQTc alarm is generated when the difference between the current value and the baseline value exceeds the set limit for more than 5 minutes.

The **Cannot Analyze QT INOP** and the **-?-** will be displayed when no QT measurement could be calculated for 10 minutes. Up to this time the previous valid value will be displayed. The following additional messages on the cause of the invalid measurements may also be displayed.

Additional Message	Cause of Invalid QT Measurement
QT Startup	QT monitoring was just turned on or has been reset
Asystole or Leads Off	1 Not all specified leads needed to perform QT analysis are available, or 2 Asystole condition is detected
Too few N labeled beats	Not enough valid QRS complexes to generate a QT measurement
Invalid Rhythm for QTc	Not enough valid RR intervals to generate QT-HR, the averaged HR used for QTc calculation
High QT-HR	QT-HR exceeds the specified upper limit of 150 bpm (for adults) or 180 bpm (for neonates and pediatrics)
Small R Wave	R-wave of the signal is too small
Small T Wave	T-wave of the signal is too small
End of T not Detected	End of the T-Wave cannot be accurately detected
QT out of Range	QT measurement is outside the specified range of valid QT values (200-800 msec)
QTc out of Range	QTc measurement is outside the specified range of valid QTc values (200-800 msec)
QTc Erratic	QTc measurements are not stable

Switching Individual QTc Alarms On and Off

Each QTc alarm can be switched off individually.

To switch an alarm on or off, in the **Setup QT Analysis** menu, select **QTc High Alarm** or **ΔQTc High Alarm** to toggle between **On** and **Off**.

Changing QTc Alarm Limits

Set the high alarm limits based on your assessment of the patient's clinical condition, unit protocols, physician orders or medication specified limits.

- 1 In the **Setup QT Analysis** menu, select **QTc High Limit**.
- 2 Select the appropriate setting.
- 3 Select **ΔQTc High Limit**.
- 4 Select the appropriate setting.

Switching QT Monitoring On and Off

To switch all QT monitoring on or off, in the **Setup QT Analysis** menu, select **QT Analysis** to switch between **On** and **Off**.

Monitoring Pulse Rate

The pulse numeric counts the arterial pulsations that result from the mechanical activity of the heart in beats per minute (bpm). You can display a pulse from any measured SpO₂ signal (pleth wave), or any arterial pressure (P, ABP, ART, Ao, PAP, UAP, FAP, BAP: see the “Monitoring Invasive Pressure” chapter for an explanation of the pressure labels). The displayed pulse numeric is labeled and color-coded to match its source wave. If the pulse numeric is not displayed, see the **Setup Pulse** menu to check whether it is switched on.

Entering the Setup Pulse Menu

If a pulse numeric is displayed on the screen, select it to enter the setup menu for that pulse source. If no pulse numeric is visible, in the setup menu from the measurement, select pulse with the correct source, e.g. **Pulse (HR)**.

System Pulse Source

The currently selected system pulse source is shown in the setup menus of the pulse source measurements. The pulse rate chosen as system pulse:

- is monitored as system pulse and generates alarms when you select pulse as the active alarm source
- is sent via the network to the Information Center, if available
- is trended in the HighRes Trends and stored in the monitor's databases.

To define which pulse rate is used as system pulse,

- 1 In the **Setup Pulse** menu, select **System Pulse**.
- 2 Select one of the SpO₂, cmResp or arterial pressure labels from the pop-up list, or select **Auto**.
If you select **Auto**, the monitor automatically chooses a pulse rate to be used as system pulse. It looks through the list from top to bottom and activates the first pulse rate that is switched on and available.

If your selected pulse source measurement becomes unavailable or is switched off, the monitor will use the next measurement from the list as system pulse until the selected pulse source measurement becomes available again.

Switching Pulse On and Off

To switch a particular pulse numeric on or off, enter the **Setup Pulse** menu via the measurement setup menu or wave menu of the pulse source. For example, to switch an SpO₂ pulse numeric on or off,

- 1 Enter the **Setup Pulse** menu by selecting the Pulse numeric or by selecting **Pulse** in the **Setup SpO₂** menu.
- 2 In the **Setup Pulse** menu, select the correct pulse label, e.g. **Pulse (SpO₂)**, to toggle between **On** and **Off**.

Using Pulse Alarms

You can change pulse rate alarm limits in the **ECG/Pulse Alarms** menu which can be accessed from the **Setup Pulse** menu or the **Setup ECG** menu by selecting **Alarm Source**. Changing the alarm limits for a specific Pulse numeric changes the alarm limits for all pulse rate alarms and heart rate alarms.

Pulse alarms are only generated when the active alarm source is set to **Pulse**, a pulse source is set as system pulse and pulse alarms are switched on.

Selecting the Active Alarm Source: ECG or Pulse?

In most cases the HR and Pulse numerics are identical. In order to avoid simultaneous alarms on HR and Pulse, the monitor uses either ECG or Pulse as its active alarm source. To change the alarm source, select **Alarm Source** in the **ECG/Pulse Alarms** menu, then select

- **ECG/Arrhythm**: if you want the HR to be the alarm source for HR/Pulse.
- **Pulse**: If you select Pulse as the active alarm source, the monitor will prompt you to confirm your choice. Be aware that if you select Pulse as the alarm source, all arrhythmia and ECG HR alarms are switched off.
- **Auto**: If the alarm source is set to **Auto**, the monitor will use the heart rate from the ECG measurement as the alarm source whenever the ECG measurement is switched on and at least one ECG lead can be measured without an INOP condition.

The monitor will automatically switch to Pulse as the alarm source if:

- a valid ECG lead can no longer be measured
- and
- a Pulse source is switched on and available,

The monitor then uses the pulse rate from the measurement currently active as system pulse.

While Pulse is the alarm source, all arrhythmia and ECG HR alarms are switched off. If an ECG lead becomes available again, the monitor automatically uses HR as alarm source.

Note:

If ECG is switched off, the monitor will always change to Pulse as alarm source, if a Pulse is available. One exception to this rule can arise when you have a telemetry device paired with your monitor. The monitor ECG is then deactivated but the monitor may be configured to allow only ECG as the active alarm source. In this case the monitor will not switch to Pulse as alarm source and Pulse will not be available as a selection in the **ECG/Pulse Alarms** menu.

WARNING

Selecting Pulse as the active alarm source for HR/Pulse switches off the arrhythmia alarms listed in the section “ECG and Arrhythmia Alarm Overview” on page 149, including **Asystole**, **Vfib** and **Vtach** alarms, and the heart rate alarms. This is indicated by the message **ECG/Arrh AlarmsOff** (unless this has been configured off for your monitor), and the crossed-out alarm symbol beside the ECG heart rate numeric. The message **ECG/Arrh AlarmsOff** can be configured off, or to switch to a yellow (medium severity) INOP after a fixed number of hours.

High and low pulse rate and extreme bradycardia and extreme tachycardia alarms from pulse are active.

Alarm Source Selection Disabled

If you cannot change the alarm source, selection of the alarm source may be disabled. If you try to change the source, the monitor displays the message **To activate enter Config and enable Alarm Source Selection**. This setting can only be changed in Configuration Mode.

Changing HR/Pulse Alarm Limits

As Pulse and HR share the same high and low alarm limits, if you change the alarm limit in the **Setup Pulse** menu, the high or low alarm limits for HR in the **Setup ECG** menu change automatically, and vice versa. The only exceptions are caused by a low limit clamp for each measurement: the lowest value for Pulse when derived from SpO₂ is 30 bpm; from HR 15 bpm, and from Pressure 25 bpm.

Extreme Alarm Limits for Heart Rate

The extreme rate alarms, ***** Extreme Tachy** and ***** Extreme Brady**, generated by the active alarm source, either HR or Pulse, are set in Configuration Mode by adding a set value to the high and low alarm limits. You need to know what value has been configured for your monitor. Changing the high and low alarm limits automatically changes the extreme alarm limits within the allowed range.

- To see the values added to the high and low limit alarms to create the extreme rate alarms for your monitor, in the **Setup ECG** menu, see the menu items **Δ ExtrTachy** and **Δ ExtrBrady**.

QRS Tone

The active alarm source is also used as a source for the QRS tone. You can change the tone volume in the **Setup SpO₂** and **Setup ECG** menus and the QRS tone modulation in the **Setup SpO₂** menu.

WARNING

The audible QRS tone might be influenced by external interference and is not intended to be used as a substitute for ECG based arrhythmia analysis.

If arrhythmia detection is needed, do not rely on the audible QRS tone.

Monitoring Respiration Rate (Resp)

For the respiratory measurement (Resp), the monitor measures the thoracic impedance between two ECG electrodes on the patient's chest. Changes in the impedance due to thoracic movement produce the Resp waveform on the monitor screen. The monitor counts the waveform cycles to calculate the respiration rate (RR).

Lead Placement for Monitoring Resp

Correct patient skin preparation techniques for electrode placement are important for Resp measurement: you will find this information in the chapter on ECG.

The Resp measurement uses the standard ECG cable sets and lead placements. You can use any of the different types of ECG cable sets - 3-lead, 5-lead, 6-lead or 10-lead, using either standard or EASI™ placement - to measure Resp, as long as you use ICU ECG cables.

The Resp signal is always measured between two of the ECG electrodes. If you are using standard ECG electrode placement, Resp is measured between the RA and LL electrodes. If you are using EASI™ ECG electrode placement, Resp is measured between the I and A electrodes.

Optimizing Lead Placement for Resp

If you want to measure Resp and you are already measuring ECG, you may need to optimize placement of the two electrodes between which Resp will be measured for some patients.

Repositioning ECG electrodes from standard positions, especially when you are using EASI™ ECG electrode placement, results in changes in the ECG waveform and may influence ST and arrhythmia interpretation.

Cardiac Overlay

Cardiac activity that affects the Resp waveform is called cardiac overlay. It happens when the Resp electrodes pick up impedance changes caused by the rhythmic blood flow. Correct electrode placement can help to reduce cardiac overlay: avoid the liver area and the ventricles of the heart in the line between the respiratory electrodes. This is particularly important for neonates.

Lateral Chest Expansion

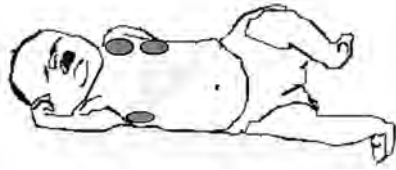

Some patients, especially neonates, expand their chests laterally. In these cases it is best to place the two respiratory electrodes in the right midaxillary and left lateral chest areas at the patient's maximum point of breathing movement to optimize the respiratory wave.

Abdominal Breathing

Some patients with restricted chest movement breathe mainly abdominally. In these cases, you may need to place the left leg electrode on the left abdomen at the point of maximum abdominal expansion to optimize the respiratory wave.

Understanding the Resp Display

The Resp measurement is displayed on the monitor as a continuous wave and a numeric respiration rate. If the detected respiration rate is close to the heart rate, this is indicated by the text **HR = RR** next to the respiration wave if you are in manual monitoring mode. Your monitor screen may look slightly different from the illustration.

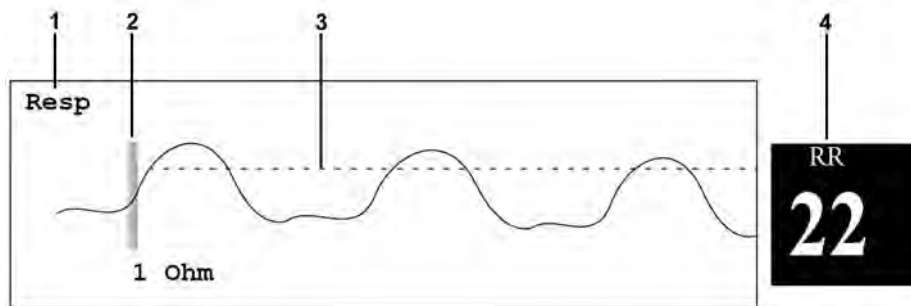

- 1 Resp wave label
- 2 One Ohm calibration bar
- 3 Manually-set Resp detection level
- 4 Resp numeric and label

Changing Resp Detection Modes

The Resp detection level can be set either automatically or manually.

- To change the resp detection mode, in the **Setup Resp** menu, select **Detection** to toggle between the settings.

Auto Detection Mode

In Auto Detection Mode, the monitor adjusts the detection level automatically, depending on the wave height and the presence of cardiac artifact. Note that in Auto Detection Mode,

- the detection level (a dotted line) is not displayed on the waveform,
- the algorithm expects a heart rate and therefore needs at least 3 electrodes attached to the patient. If you are monitoring respiration with only two electrodes, the detection algorithm becomes less sensitive which may result in reduced breath detection performance.

Use Auto Detection Mode for situations where:

- the respiration rate is not close to the heart rate
- breathing is spontaneous, with or without continuous positive airway pressure (CPAP)
- patients are ventilated, except patients with Intermittent Mandatory Ventilation (IMV).

Manual Detection Mode

In Manual Detection Mode you must set the Resp detection level.

- In the **Setup Resp** menu, select **Manual Up** or **Manual Down**. Use the dotted detection level line in the Resp waveform to determine when the desired level is reached.

Once set, the detection level will not adapt automatically to different respiration depths. It is important to remember that if the depth of breathing changes, you may need to change the detection level.

Use Manual Detection Mode for situations where:

- the respiration rate and the heart rate are close.
- patients have Intermittent Mandatory Ventilation.
- respiration is weak. Try repositioning the electrodes to improve the signal.

Resp Detection Modes and Cardiac Overlay

In Auto Detection Mode:

If you are monitoring Resp and the ECG is switched off, the monitor cannot compare the ECG and Resp rates to detect cardiac overlay. The respiration detection level is automatically set higher to prevent the detection of cardiac overlay as respiration.

In Manual Detection Mode:

Cardiac overlay can in certain situations trigger the respiration counter. This may lead to a false indication of a high respiration rate or an undetected apnea condition. If you suspect that cardiac overlay is being registered as breathing activity, raise the detection level above the zone of cardiac overlay. If the Resp wave is so small that raising the detection level is not possible, you may need to optimize the electrode placement as described in the section “Lateral Chest Expansion” on page 186.

Changing the Size of the Respiration Wave

WARNING

When monitoring in Manual Detection Mode, make sure to check the respiration detection level after you have increased or decreased the size of the respiration wave.

- In the **Setup Resp** menu, select **Size Up** to increase the size of the wave or **Size Down** to decrease it.

Changing the Speed of the Respiration Wave

Resp waveforms are usually viewed at a slower speed than other waveforms. For this reason, the Resp measurement has its own speed control and is not affected by the wave speed settings of the other measurements.

- Select the Resp wave to enter the **Resp Wave** menu, then select **Change Speed**. Choose the required speed from the pop-up list. This defines the speed at which the wave is drawn across the screen in millimeters per second (mm/s).

Using Resp Alarms

Resp alarms can be switched on and off and the high and low alarm limits can be changed just like other measurement alarms, as described in the Alarms chapter.

Changing the Apnea Alarm Delay

The apnea alarm is a high priority red alarm used to detect apneas. The apnea alarm delay time defines the time period between the point where the monitor cannot detect any respiration activity and the indication of the apnea alarm.

- 1 In the **Setup Resp** menu, select **Apnea Time**.
- 2 Select the appropriate setting.

Resp Safety Information

WARNING

Respiration detection level

If you do not set the detection level for the respiration correctly in manual detection mode, it may not be possible for the monitor to detect apnea. If you set the detection level too low, the monitor is more likely to detect cardiac activity, and to falsely interpret cardiac activity as respiratory activity in the case of apnea.

Apnea

The respiration measurement does not recognize obstructive and mixed apneas - it only indicates an alarm when a pre-adjusted time has elapsed since the last detected breath.

The safety and effectiveness of the respiration measurement method in the detection of apnea, particularly the apnea of prematurity and apnea of infancy, has not been established.

Interference

If operating under conditions according to the EMC Standard EN 60601-1-2 (Radiated Immunity 3V/m), field strengths above 1V/m may cause erroneous measurements at various frequencies. Therefore it is recommended to avoid the use of electrically radiating equipment in close proximity to the respiration measurement unit.

Resp Accessories

To monitor respiration, use only the non-OR ECG accessories listed in the Resp section of the accessories chapter. You cannot measure respiration if you are using an orange OR ECG cable set.

This is because of the higher internal impedance of the OR cable set, required for use if electrosurgery is being performed.

Rate adaptive pacemakers

Implanted pacemakers which can adapt to the Minute Ventilation rate may occasionally react on the Impedance measurement used by patient monitors for the determination of the Resp value and execute pacing with the maximum programmed rate. Switching off the Resp measurement can prevent this.

Monitoring SpO₂

Philips pulse oximetry uses a motion-tolerant signal processing algorithm, based on Fourier artifact suppression technology (FAST). It provides four measurements:

- Oxygen saturation of arterial blood (SpO₂) - percentage of oxygenated hemoglobin in relation to the sum of oxyhemoglobin and deoxyhemoglobin (functional arterial oxygen saturation).
- Pleth waveform - visual indication of patient's pulse.
- Pulse rate (derived from pleth wave) - detected pulsations per minute.
- Perfusion indicator - numerical value for the pulsatile portion of the measured signal caused by arterial pulsation.

The monitors are also compatible with SpO₂ technologies from other manufacturers. Refer to the instructions for use provided with these devices for further information.

SpO₂ Sensors

Depending on the purchased SpO₂ option, different sensors and adapter cables can be used. The sensors for the different options are color-coded to match the connectors. See the “Accessories” chapter for a compatibility table.

Familiarize yourself with the instructions for use supplied with your sensor before using it. In particular, check that the sensor being used is appropriate for your patient category and application site.

CAUTION

Do not use OxiCliq disposable sensors in a high humidity environment, such as in neonatal incubators or in the presence of fluids, which may contaminate sensor and electrical connections causing unreliable or intermittent measurements. **Do not use** disposable sensors when there is a known allergic reaction to the adhesive.

Always use the MAX-FAST forehead sensor with the foam headband provided by Nellcor.

Applying the Sensor

- 1 Follow the SpO₂ sensor's instructions for use, adhering to all warnings and cautions.
- 2 Remove colored nail polish from the application site.

- 3 Apply the sensor to the patient. The application site should match the sensor size so that the sensor can neither fall off, nor apply excessive pressure.
When using the M1195A Infant Finger Sensor, select a finger or toe with a diameter of between 7 and 8 mm (0.27" and 0.31"). When applying a M1193A neonatal sensor do not overtighten the strap.
- 4 Check that the light emitter and the photodetector are directly opposite each other. All light from the emitter must pass through the patient's tissue.

WARNING

Proper Sensor Fit: If a sensor is too loose, it might compromise the optical alignment or fall off. If it is too tight, for example because the application site is too large or becomes too large due to edema, excessive pressure may be applied. This can result in venous congestion distal from the application site, leading to interstitial edema, hypoxemia and tissue malnutrition. Skin irritations or lacerations may occur as a result of the sensor being attached to one location for too long. To avoid skin irritations and lacerations, periodically inspect the sensor application site and change the application site regularly.

Venous Pulsation: Do not apply sensor too tightly as this results in venous pulsation which may severely obstruct circulation and lead to inaccurate measurements.

Ambient Temperature: At elevated ambient temperatures be careful with measurement sites that are not well perfused, because this can cause severe burns after prolonged application. All listed sensors operate without risk of exceeding 41°C on the skin if the initial skin temperature does not exceed 35°C.

Extremities to Avoid: Avoid placing the sensor on extremities with an arterial catheter, an NBP cuff or an intravascular venous infusion line.

Connecting SpO₂ Cables

Connect the sensor cable to the color-coded socket on the measurement device (MMS or module). You can connect some Philips sensors directly to the measurement device. For other sensors, use the corresponding adapter cable.

CAUTION

Extension cables: Do not use more than one extension cable (M1941A). Do not use an extension cable with Philips reusable sensors or adapter cables with part numbers ending in -L (indicates "long" cable version).

Electrical Interference: Position the sensor cable and connector away from power cables, to avoid electrical interference.

Humidity: For neonatal patients, make sure that all sensor connectors and adapter cable connectors are outside the incubator. The humid atmosphere inside can cause inaccurate measurements.

Measuring SpO₂

- 1 Select the correct patient category setting (adult/pediatric and neonatal), as this is used to optimize the calculation of the SpO₂ and pulse numerics.

- 2 During measurement, ensure that the application site:
 - has a pulsatile flow, ideally with a perfusion indicator value above 1.0.
 - has not changed in its thickness (for example, due to edema), causing an improper fit of the sensor.

WARNING

- For fully conscious pediatric or adult patients, who have a normal function of perfusion and sensory perception at the measurement site:

To ensure skin quality and correct optical alignment of the sensor, inspect the application site when the measurement results are suspicious or when the patient complains about pressure at the application site, but at least every 24 hours. Correct the sensor alignment if necessary. Move the sensor to another site, if the skin quality changes.
 - For all other patients:

Inspect the application site every two to three hours to ensure skin quality and correct optical alignment. Correct the sensor alignment if necessary. If the skin quality changes, move the sensor to another site.

Change the application site at least every four hours.
 - Injected dyes such as methylene blue, or intravascular dyshemoglobins such as methemoglobin and carboxyhemoglobin may lead to inaccurate measurements.
 - Inaccurate measurements may result when the application site for the sensor is deeply pigmented or deeply colored, for example, with nail polish, artificial nails, dye or pigmented cream.
 - Interference can be caused by:
 - High levels of ambient light (including IR warmers) or strobe lights or flashing lights (such as fire alarm lamps). (Hint: cover application site with opaque material.)
 - Another SpO₂ sensor in close proximity (e.g. when more than one SpO₂ measurement is performed on the same patient). Always cover both sensors with opaque material to reduce cross-interference.
 - Electromagnetic interference, especially at perfusion indicator values below 1.0 or signal quality indicator below medium.
 - Excessive patient movement and vibration.
-

SpO₂ Signal Quality Indicator (FAST SpO₂ only)

The SpO₂ numeric is displayed together with a signal quality indicator (if configured and enough space is available) which gives an indication of the reliability of the displayed values.

The level to which the triangle is filled shows the quality of the signal; the indicator below shows a medium signal quality, the signal quality is at a maximum when the triangle is completely filled.



Assessing a Suspicious SpO₂ Reading

Traditionally, pulse rate from SpO₂ was compared with heart rate from ECG to confirm the validity of the SpO₂ reading. With newer algorithms, such as FAST-SpO₂, this is no longer a valid criteria because the correct calculation of SpO₂ is not directly linked to the correct detection of each pulse.

When pulse rate is very low, or strong arrhythmia is present, the SpO₂ pulse rate may differ from the heart rate calculated from ECG but this does not indicate an inaccurate SpO₂ value.

If you doubt the measured SpO₂, use the signal quality indicator (if available) or the pleth wave and perfusion indicator instead to assess the signal quality.

WARNING

With pulse oximetry, sensor movement, ambient light (especially strobe lights or flashing lights) or electromagnetic interference can give unexpected intermittent readings when the sensor is not attached. Especially bandage-type sensor designs are sensitive to minimal sensor movement that might occur when the sensor is dangling.

Changing the Averaging Time

Depending on the monitor configuration, you may be able to change the averaging time for the SpO₂ values.

The averaging time represents the approximate time period used for the calculation. The exact averaging algorithm depends on the SpO₂ technology (option) used and on the signal conditions. The longer the averaging time, the longer the time needed until the SpO₂ value reflects the physiological event. Fast averaging is useful for situations where an extremely fast measurement is required or few artifacts are expected. Use slow averaging where you expect the number of artifacts to be relatively high.

- 1 In the **Setup SpO₂** menu, select **Average**.
- 2 Select the required averaging time from the list.

Understanding SpO₂ Alarms

This refers to SpO₂ specific alarms. See the “Alarms” chapter for general alarm information. SpO₂ offers high and low limit alarms, and a high priority desat alarm. You cannot set the low alarm limit below the desat alarm limit.

CAUTION

If you measure SpO₂ on a limb that has an inflated noninvasive blood pressure cuff, a non-pulsatile SpO₂ INOP can occur. If the monitor is configured to suppress this alarm there may be a delay of up to 60 seconds in indicating a critical status, such as sudden pulse loss or hypoxia.

Alarm Delays

There is a delay between a change in the oxygen saturation at the measurement site and the corresponding alarm indication at the monitor. This delay has two components:

- **The general measurement delay time is the time between the occurrence of the saturation change and when the new value is represented by the displayed numerical values.** This delay depends on the algorithmic processing and the averaging time configured for SpO₂. The longer the averaging time configured, the longer the time needed until the numerical values reflect the change in saturation.
- **The time between the displayed numerical values crossing an alarm limit and the alarm indication on the monitor.** This delay is the sum of the alarm delay time configured for SpO₂, plus the system alarm delay. The system alarm delay is the processing time the system needs for any alarm to be indicated on the monitor, after the measurement has triggered the alarm. See “Monitor Performance Specifications” on page 464 for the system alarm delay specification.

For SpO₂ high and low limit alarms, there are two different types of alarm delay time. The **standard alarm delay** is set to a fixed value. The **Smart Alarm Delay** varies, based on an intelligent algorithm, and can be used instead of the standard alarm delay.

The **Desat** alarm always uses the standard alarm delay.

Standard Alarm Delay

The standard alarm delay time can be configured to a fixed value between 0 and 30 seconds, in 1 second steps.

Smart Alarm Delays

The Smart Alarm Delay functionality is currently not available in China or in clinical environments under SFDA control.

When Smart Alarm Delays are used, the delay before the indication of an SpO₂ high or low limit alarm depends on the amount by which the limit is exceeded and for how long. This capability can be used to avoid alarms when the SpO₂ values show a pattern of recovering after a limit violation.

There are three modes available, Short, Medium and Long. All modes have a minimum delay of 10 seconds. The maximum delay is 25 seconds for Short mode, 50 seconds for Medium mode and 100 seconds for Long mode.

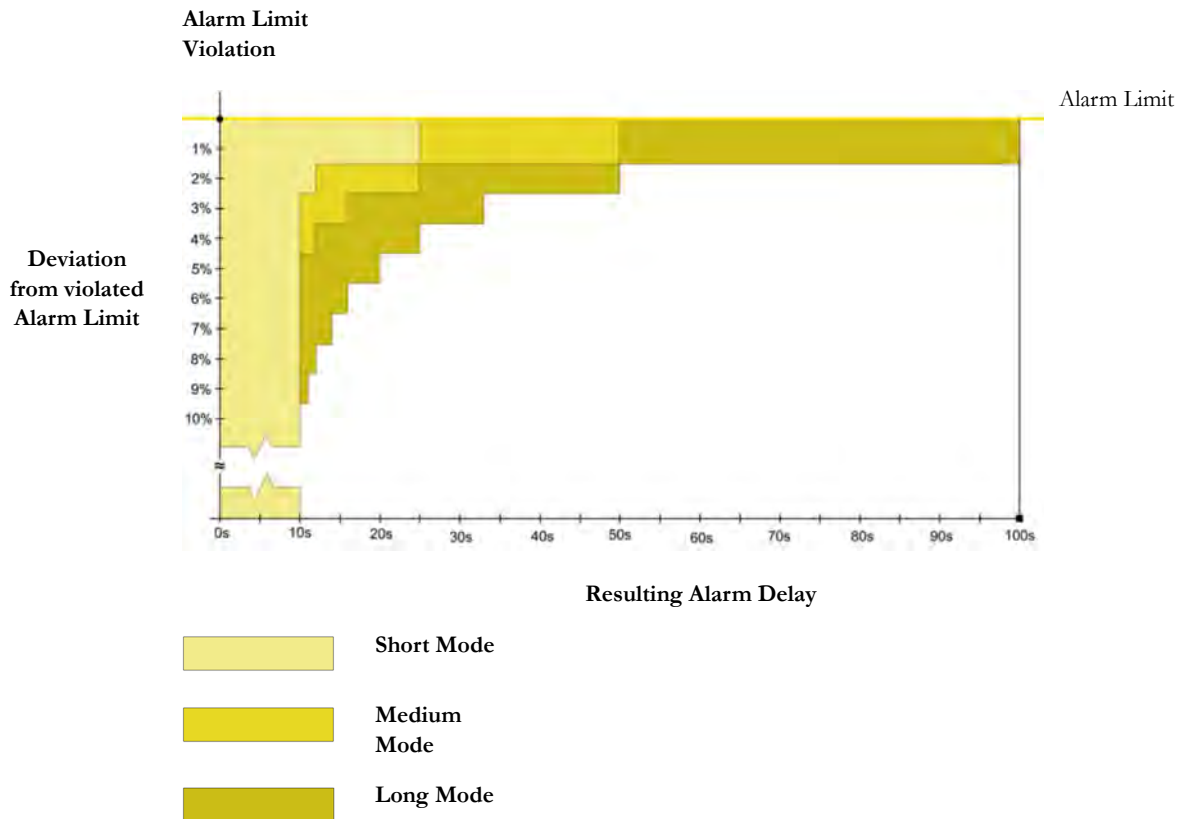

This diagram shows the relationship between the alarm delay and the deviation from the alarm limit. The shaded areas on the diagram show the area in which SpO₂ values can violate the alarm limit without causing an alarm to be indicated. The area is smallest for the Short mode, and is extended for the Medium and Long modes by the corresponding areas shown above.

WARNING

Before using Smart Alarm Delays, make sure that you fully understand how the delay is applied and what the consequences are.

Example With Short Mode

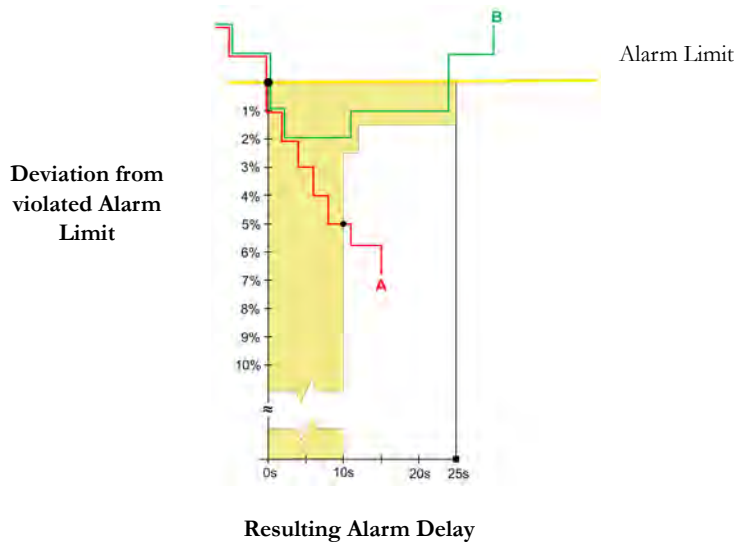

This diagram shows the area for Short mode, with two examples of hypoxia.

Progressive hypoxia scenario: SpO₂ value (A) - the values drop steadily and after 10 seconds a value leaves the shaded area. An alarm is indicated immediately.

Recovery scenario: SpO₂ value (B) - the values stay within the shaded area for 24 seconds, deviating from the alarm limit by 1% or 2%, before rising again above the alarm limit. No alarm is indicated because the SpO₂ values never leave the shaded area below the alarm limit.

On the basis of the two examples, you can see that the delay depends on how much the value exceeds the limit, and for how long. Changes in the SpO₂ value can be major, but very short, or minor and for a longer time - as long as they stay within the shaded area there will be no alarm indicated.

Example With Medium Mode

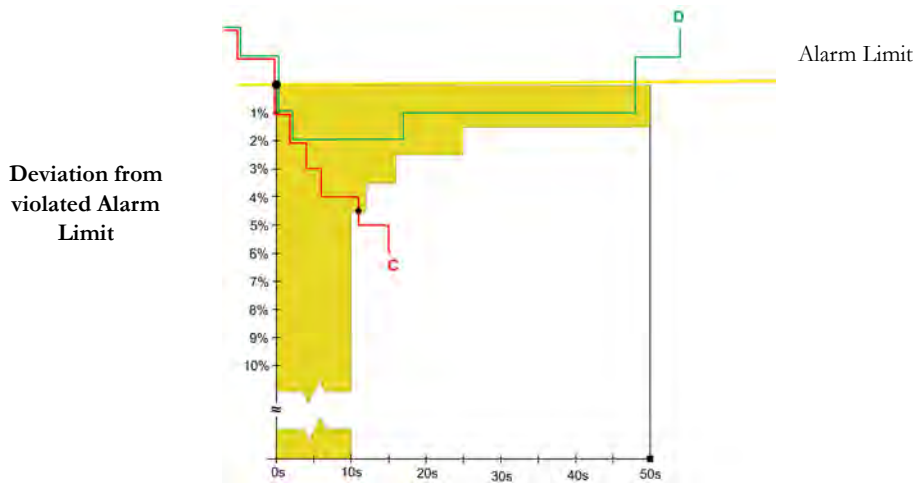

Resulting Alarm Delay

This diagram shows the area for Medium mode, with two examples of hypoxia.

Progressive hypoxia scenario: SpO₂ value (C) - the values drop steadily and after 11 seconds a value leaves the shaded area. An alarm is indicated immediately.

Recovery scenario: SpO₂ value (D) - the values stay within the shaded area for 48 seconds, deviating from the alarm limit by 1% or 2%, before rising again above the alarm limit. No alarm is indicated because the SpO₂ values never leave the shaded area below the alarm limit.

Example With Long Mode

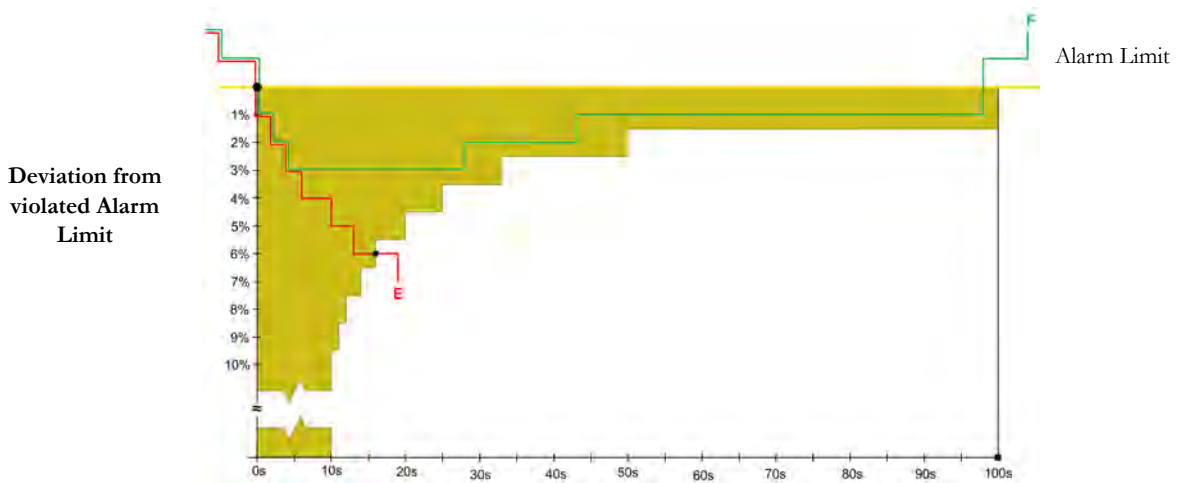

Resulting Alarm Delay

This diagram shows the area for Long mode, with two examples of hypoxia.

Progressive hypoxia scenario: SpO₂ value (E) - the values drop steadily and after 16 seconds a value leaves the shaded area. An alarm is indicated immediately.

Recovery scenario: SpO₂ value (F) - the values stay within the shaded area for 98 seconds, deviating from the alarm limit by 1% to 3%, before rising again above the alarm limit. No alarm is indicated because the SpO₂ values never leave the shaded area below the alarm limit.

Setting Smart Alarm Delay Mode

To set the mode for Smart Alarm Delays, in the **Setup SpO₂** menu,

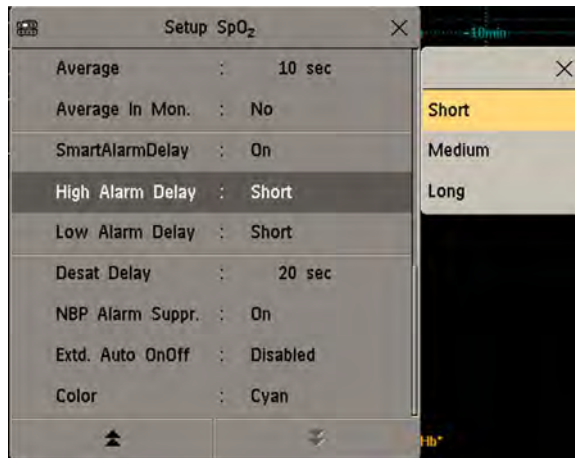

- 1 Check that **SmartAlarmDelay** is set to **On**.
This setting is made in Configuration mode and will be shown in the menu in gray. If it is set to **Off**, a standard alarm delay is in use.
- 2 Select **High Alarm Delay** and choose **Short**, **Medium**, or **Long** mode.
- 3 Select **Low Alarm Delay** and choose **Short**, **Medium**, or **Long** mode.

If you also use monitors with earlier software revisions, be aware that smart alarm delays will not be used after a transfer to one of these monitors. Monitors with earlier software revisions will always use the standard alarm delay. If you are not sure whether a monitor has the Smart Alarm Delay function, check whether there is a **SmartAlarmDelay** entry in the **Setup SpO₂** menu.

Adjusting the Alarm Limits

In the **Setup SpO₂** menu:

- Select **High Limit** then choose the high alarm limit.
- Select **Low Limit** then choose the low alarm limit.

WARNING

High oxygen levels may predispose a premature infant to retrolental fibroplasia. If this is a consideration do NOT set the high alarm limit to 100%, which is equivalent to switching the high alarm off.

Adjusting the Desat Limit Alarm

The Desat alarm is a high priority (red) alarm notifying you of potentially life threatening drops in oxygen saturation.

- 1 In the **Setup SpO₂** menu, select **Desat Limit**.
- 2 Adjust the limit.

Pleth Wave

The Pleth wave is autoscaled to maximum display size. It decreases only when the signal quality becomes marginal. It is NOT directly proportional to the pulse volume. If you need an indication of change in pulse volume, use the perfusion indicator.

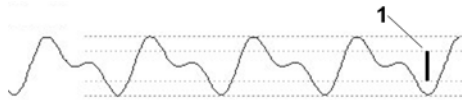

- 1 Minimum size for reliable SpO₂ value

Perfusion Numeric

The perfusion numeric (**Perf**) gives a value for the pulsatile portion of the measured signal caused by the pulsating arterial blood flow.

As pulse oximetry is based on the pulsatile nature of the signal, you can also use the perfusion numeric as a quality indicator for the SpO₂ measurement. Above 1 is optimal, between 0.3-1 is acceptable.

Below 0.3 is marginal; reposition the sensor or find a better site.

Perfusion Change Indicator

The perfusion change indicator is a graphic symbol which shows the change in the perfusion value, relative to a reference value which you can set.

To set the current perfusion value as the reference value:

- In the **Setup SpO₂** menu, select **Set Perf Ref.**

When a reference value has been set, the perfusion change indicator is displayed next to the perfusion numeric.



Setting SpO₂/Pleth as Pulse Source

- 1 In the **Setup SpO₂** menu, select **Pulse (SpO₂)** to enter the **Setup Pulse** menu.
- 2 In the **Setup Pulse** menu, select **System Pulse** and select the correct SpO₂ label from the pop-up list.

Setting Up Tone Modulation

If tone modulation is on, the QRS tone pitch lowers when the SpO₂ level drops. Remember, the QRS tone is derived from either heart rate or pulse depending on which is currently selected as the active alarm source.

In the **Setup SpO₂** menu, select **Tone Modulation** to switch between **Yes** (for on) and **No** (for off).

Tone modulation is licensed under US patent US 4.653.498 from Nellcor Puritan Bennett Incorporated.

Setting the QRS Volume

In the **Setup SpO₂** menu, select **QRS Volume** and set the appropriate QRS tone volume.

Calculating SpO₂ Difference

When a second SpO₂ measurement is present (either through the SpO₂ module or through an external device), the monitor displays both SpO₂ values, and calculates the difference between them. The second value is subtracted from the first.

- 1 From the **Main Setup** menu, select **Measurements**.
- 2 From the **Setup Δ SpO₂** menu, select **First SpO₂**.
- 3 Choose the first measurement source.
- 4 Select **Second SpO₂**.
- 5 Choose the second measurement source.

Monitoring NBP

This monitor uses the oscillometric method for measuring NBP.

The NBP measurement is suitable for use in the presence of electrosurgery and during the discharge of a cardiac defibrillator according to IEC 601-2-30:1999/EN 60601-2-30:2000.

A physician must determine the clinical significance of the NBP information.

Introducing the Oscillometric NBP Measurement

Oscillometric devices measure the amplitude of pressure changes (oscillations) in the occluding cuff as the cuff deflates from above systolic pressure. The amplitude suddenly increases as the pulse breaks through the occlusion in the artery. As the cuff pressure decreases further, the pulsations increase in amplitude, reach a maximum (which approximates to the mean pressure), and then diminish.

Studies show that, especially in critical cases (arrhythmia, vasoconstriction, hypertension, shock), oscillometric devices are more accurate and consistent than devices using other noninvasive measuring techniques.

WARNING

Patient Category: Select the correct patient category setting for your patient. Do not apply the higher adult inflation, overpressure limits and measurement duration to neonatal patients.

Intravenous infusion: Do not use the NBP cuff on a limb with an intravenous infusion or arterial catheter in place. This could cause tissue damage around the catheter when the infusion is slowed or blocked during cuff inflation.

Skin Damage: Do not measure NBP in cases of sickle-cell disease or any condition where skin damage has occurred or is expected.

Existing Wounds: Do not apply the cuff over a wound as this can cause further injury.

Mastectomy: Avoid applying the cuff on the side of the mastectomy, as the pressure increases the risk of lymphedema. For patients with a bilateral mastectomy, use clinical judgement to decide whether the benefit of the measurement outweighs the risk.

Unattended Measurement: Use clinical judgement to decide whether to perform frequent unattended blood pressure measurements. Too frequent measurements can cause blood flow interference potentially resulting in injury to the patient. In cases of severe blood clotting disorders frequent measurements increase the risk of hematoma in the limb fitted with the cuff.

Temporary Loss of Function: The pressurization of the cuff can temporarily cause loss of function of monitoring equipment used simultaneously on the same limb.

CAUTION

If you spill liquid onto the equipment or accessories, particularly if there is a chance that it can get inside the tubing or the measurement device, contact your service personnel.

Measurement Limitations

NBP readings can be affected by the position of the patient, their physiological condition, the measurement site, and physical exercise. Thus a physician must determine the clinical significance of the NBP information.

Measurements are impossible with heart rate extremes of less than 40 bpm or greater than 300 bpm, or if the patient is on a heart-lung machine.

The measurement may be inaccurate or impossible:

- with excessive and continuous patient movement such as shivering or convulsions
- if a regular arterial pressure pulse is hard to detect with cardiac arrhythmias
- with rapid blood pressure changes
- with severe shock or hypothermia that reduces blood flow to the peripheries
- with obesity, where a thick layer of fat surrounding a limb dampens the oscillations coming from the artery
- on an edematous extremity.

The effectiveness of this sphygmomanometer has not been established in pregnant, including pre-eclamptic patients.

When the **accelerated measurement** is used the minimum number of oscillations per deflation step is 1, instead of the 2 in the standard measurement. This allows a faster measurement result but requires that the patient keeps the limb in question still. The accelerated measurement is recommended for use when very few or no artifacts are expected, for example with sedated patients.

You can see whether the accelerated measurement is in use by looking in the **Setup NBP** menu. The **Accelerated Msmt** setting shows whether the accelerated measurement is **Off**, on for **Manual** measurements or on for **All** measurements. This setting is view-only in Monitoring Mode and can be changed in Configuration Mode. When the accelerated measurement is in use, no pulse rate is derived from NBP.

Measurement Modes

There are four modes for measuring NBP:

- **Manual** - measurement on demand.
- **Auto** - continually repeated measurements (between one minute and 24 hours adjustable interval).
- **Sequence** - up to four measurement cycles which will run consecutively, with number of measurements and interval between them configurable for each cycle.
- **STAT** - rapid series of measurements over a five minute period, then the monitor returns to the previous mode. Use only on supervised patients.

Reference Method

The measurement reference method can be Auscultatory (manual cuff) or Invasive (intra-arterial). For further information, see the Application Note supplied on the monitor documentation DVD.

In Neonatal mode, to comply with safety standards, invasive is always used as the reference method. This setting cannot be changed and is not visible in any operating mode.

In Adult and Pediatric mode, to check the current setting, select **Main Setup** then **Measurements** followed by **NBP**, and check whether the **Reference** setting is set to **Auscultatory** or **Invasive**. This setting can only be changed in Configuration Mode.

Preparing to Measure NBP

- 1 Connect the cuff to the air tubing.
- 2 Plug the air tubing into the red NBP connector. Avoid compression or restriction of pressure tubes. Air must pass unrestricted through the tubing.

WARNING

Kinked or otherwise restricted tubing can lead to a continuous cuff pressure, causing blood flow interference and potentially resulting in injury to the patient.

- 3 Make sure that you are using a Philips-approved correct sized cuff and that the bladder inside the cover is not folded or twisted.
A wrong cuff size, and a folded or twisted bladder, can cause inaccurate measurements. The width of the cuff should be in the range from 37% to 47% of the limb circumference. The inflatable part of the cuff should be long enough to encircle at least 80% of the limb.
- 4 Apply the cuff to a limb at the same level as the heart. If it is not, you must use the measurement correction formula to correct the measurement.
The marking on the cuff must match the artery location. Do not wrap the cuff too tightly around the limb. It may cause discoloration, and ischemia of the extremities.

WARNING

Inspect the application site regularly to ensure skin quality and inspect the extremity of the cuffed limb for normal color, warmth and sensitivity. If the skin quality changes, or if the extremity circulation is being affected, move the cuff to another site or stop the blood pressure measurements immediately. Check more frequently when making automatic or stat measurements.

Correcting the Measurement if Limb is not at Heart Level

To correct the measurement if the limb is not at heart level, to the displayed value

Add 0.75 mmHg (0.10 kPa) for each centimeter higher or	Deduct 0.75 mmHg (0.10 kPa) for each centimeter lower or
Add 1.9 mmHg (0.25 kPa) for each inch higher.	Deduct 1.9 mmHg (0.25 kPa) for each inch lower.

Recommendations For Measurements Used in Diagnosis of Hypertension

To make a measurement for use in the diagnosis of hypertension, follow the steps below:

- 1 Ensure the patient is comfortably seated, with their legs uncrossed, feet flat on the floor and back and arm supported.
- 2 Ask the patient to relax and not talk before and during the measurement.
- 3 If possible, wait 5 minutes before making the first measurement.

Understanding the NBP Numerics

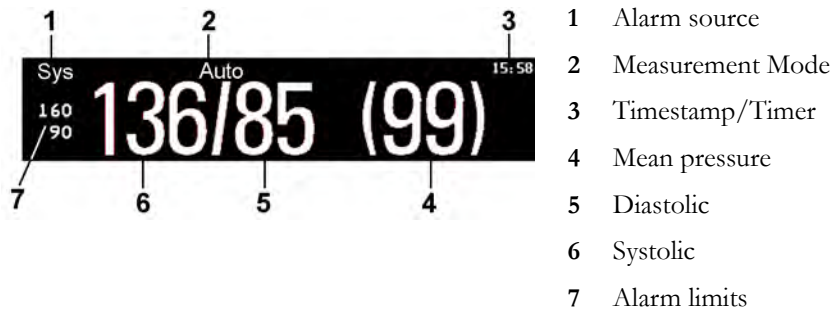

Depending on the NBP numeric size, not all elements may be visible. Your monitor may be configured to display only the systolic and diastolic values. If configured to do so, the pulse from NBP will display with the NBP numeric.

The measured NBP value, together with the corresponding pulse rate if this is switched on, will be displayed for one hour. After that the values are regarded as invalid and are no longer displayed.

During this hour, measurement values may be grayed out or disappear from the screen after a set time, if configured to do so. This avoids older numerics being misinterpreted as current data. The time can be set in Configuration mode.

In **Auto** mode the measurement values may disappear more quickly (to be replaced by new measurement values), if the repeat time is set to less than one hour.

Alarm Sources

If you have parallel alarm sources, the sources are displayed instead of the alarm limits.

NBP Measurement Timestamp

Depending on your configuration, the time shown beside the NBP numeric can be:

- the time of the most recent NBP measurement, also known as the "timestamp", or
- the time until the next measurement in an automatic series, displayed with a graphic representation of the remaining time, as shown here.



- The NBP timestamp will normally show the **completion** time of the NBP measurement.

During Measurements

The cuff pressure is displayed instead of the units and the repeat time. An early systolic value gives you a preliminary indication of the systolic blood pressure during measurement.







When Unexpected Values are Measured







When values measured are higher or lower than expected, check the following potential causes:

Possible Cause	Solution
The patient was talking or moving before or during the measurement.	Allow the patient to rest quietly, then try again after three to five minutes.
The incorrect cuff size was used or the cuff was not at heart level	Check the cuff size, level, and position then repeat the measurement.
The noninvasive blood pressure reference method is set incorrectly.	Check the reference method (auscultation or intra-arterial) in the Setup NBP menu. If it is incorrect, have it changed in Configuration Mode.
Measurement limitations have not been taken into account.	Check the list in “Measurement Limitations” on page 204.

Starting and Stopping Measurements

Use the Setup menu, SmartKeys or the MMS hardkey to start and stop measurements.

Action to be performed	NBP Setup menu	SmartKeys	MMS hardkey
Start manual measurement Start Auto series	Start/Stop	 Start/ Stop	Start/Stop
		 Start NBP	---
Start STAT measurement	NBP STAT	 NBP STAT	STAT (for MMS without Pressure/Temp measurement)
		 Start STAT	
Stop Manual measurements	Start/Stop	 Start/ Stop	Start/Stop
		 Stop NBP	

Action to be performed	NBP Setup menu	SmartKeys	MMS hardkey
Stop current Auto measurement	Start/Stop	 Start/ Stop	Start/Stop
		 Stop NBP	
Stop current STAT measurement and end series	Start/Stop	 Start/ Stop	Start/Stop
	NBP STAT	 NBP STAT	STAT (for MMS without Pressure/Temp measurement)
		 Stop NBP	
Stop Auto, Manual or STAT measurement AND series	Stop All	 Stop All	

CAUTION

Use clinical judgment to decide whether to perform repeated series of STAT measurements because of the risk of purpura, ischemia and neuropathy in the limb with the cuff.

Enabling Automatic Mode and Setting Repetition Time

- 1 In the **Setup NBP** menu, select **Mode** and select **Auto** from the pop-up menu.
- 2 For an automatic measurement, select **Repeat Time** and set the time interval between two measurements.

Enabling Sequence Mode and Setting Up The Sequence

- 1 In the **Setup NBP** menu, select **Mode** and select **Sequence** from the pop-up menu.
- 2 Select **Setup Sequence** to open the **Setup Sequence** window.
Up to four measurement cycles can be setup which will run consecutively. For each cycle you can set the number of measurements and the interval between them. If you want to run less than four cycles in a sequence, you can set the number of measurements for one or more cycles to **Off**.

- 3 Select each sequence in turn and select the number of measurements and the time interval between the measurements.
- 4 To have measurements continue after the sequence, set the number of measurements for your last cycle to **Continuous** and this cycle will run indefinitely.

CAUTION

Be aware that, if none of the cycles are set to **Continuous**, NBP monitoring will end after the last measurement of the cycle.

When the NBP measurement mode is set to **Sequence**, the repetition time for **Auto** mode cannot be changed.

Choosing the NBP Alarm Source

You can monitor for alarm conditions in systolic, diastolic and mean pressure, either singly or in parallel. Only one alarm is given, with the priority of mean, systolic, diastolic.

In the **Setup NBP** menu, select **Alarms from** and choose from:

Menu option	Pressure value monitored
Sys.	systolic
Dia.	diastolic
Mean	mean
Sys & Dia	systolic and diastolic in parallel
Dia & Mean	diastolic and mean in parallel
Sys & Mean	systolic and mean in parallel
Sys&Dia&Mean	all three pressures in parallel

If **Mean** is not selected as alarm source (**Sys.**, **Dia.**, or **Sys & Dia** selected), but the monitor can only derive a mean value, mean alarms will nevertheless be announced using the most recent mean alarm limits. Check that the mean alarm limits are appropriate for the patient, even when not using mean as the alarm source. When no value can be derived an **NBP Measure Failed** INOP will be displayed.

Switching Pulse from NBP On/Off

In the process of making the NBP measurement, a pulse value can be derived and displayed. The pulse value is displayed together with the time the measurement was made. After one hour the value becomes invalid. There are no alarms associated with pulse from NBP.

When the accelerated measurement is in use, no pulse value can be derived.

To switch the display of the pulse value on or off:

- In the **Setup NBP** menu select **Pulse (NBP)**.

Assisting Venous Puncture

You can use the NBP cuff to cause sub-diastolic pressure. The cuff deflates automatically after a set time (adult/pediatric 170 seconds, neonatal 85 seconds) if you do not deflate it.

- 1 In the **Setup NBP** menu select **VeniPuncture**.
- 2 Puncture vein and draw blood sample.
- 3 Reselect **VeniPuncture** to deflate the cuff.

During measurement, the NBP display shows the inflation pressure of the cuff and the remaining time in venous puncture mode.

NOTE

Performing a venous puncture while automatic or sequence NBP measurements are being made suspends the measurement series for the duration of the venous puncture inflation and for three minutes afterwards.

Calibrating NBP

NBP is not user-calibrated. NBP pressure transducers must be verified at least once every two years by a qualified service professional, and calibrated, if necessary. See the Service Guide for details.

Monitoring Temperature

WARNING

Measurements from an MMS extension connected to an X2 are not available when the X2 is running on its own battery power. They are only available when the X2 is powered by external power: when connected to a host monitor, to the external power supply (M8023A) or to the Battery Extension (865297).

You can measure temperature using an X1 or X2 Multi-Measurement Module (MMS), one of the MMS extensions, or the temperature plug-in module - labeled as TEMP.

Temp measurement automatically switches on when you connect a probe. You can switch the measurement off manually.

Making a Temp Measurement

- 1 Select the correct type and size of probe for your patient.
- 2 If you are using a disposable probe, connect the probe to the temperature cable.
- 3 Plug the probe or temperature cable into the temperature connector socket.
- 4 Apply the probe to the patient. You are advised to use a protective rubber cover on rectal probes.
- 5 Select an appropriate temperature label.
- 6 Check that the alarm settings (on or off, high and low limits) are appropriate for this patient and this type of temperature measurement.

WARNING

Make sure you set alarm limits for the correct label. The alarm limits you set are stored for that particular label only. Changing the label may change the alarm limits.

Selecting a Temperature for Monitoring

Tell the monitor which temperature you want to monitor by selecting its temperature label. The label is a unique identifier for each type of temperature. When you choose a label, the monitor uses that label's stored color and alarm settings.

- 1 In the **Setup <Temp Label>** menu, select **Label**.
- 2 Select the appropriate label from the list.

Temp	non-specific temperature label	Trect	rectal temperature
Tart	arterial temperature	Tskin	skin temperature
Tcore	core temperature	Tven	venous temperature
Tesoph	esophageal temperature	Tnaso	nasopharyngeal temperature

Extended Temperature Label Set

The following additional labels are available if **Label Set** is set to **Full**. This setting can only be changed in Configuration Mode.

Note that if your monitor is connected to an Information Center, the additional labels in the extended label set may not be correctly displayed. See the Configuration Guide for your monitor for more information.

T1, T2, T3, T4	Non-specific temperature labels
Tamb	ambient temperature
Tcereb	cerebral temperature
Ttymp	tympanic temperature
Tvesic	vesical temperature

Calculating Temp Difference

The monitor can calculate and display the difference between two temperature values by subtracting the second value from the first. The difference is labeled **ΔTemp**.

- 1 In the **Main Setup** menu, select **Measurements**.
- 2 Select **ΔTemp**.
- 3 In the **Setup ΔTemp** menu, select **First Temp**.
- 4 Select the appropriate label for the measurement source.
- 5 Select **Second Temp**.
- 6 Select the appropriate label for the second measurement source.

Monitoring Invasive Pressure

WARNING

Measurements from an MMS extension connected to an X2 are not available when the X2 is running on its own battery power. They are only available when the X2 is powered by external power: when connected to a host monitor, to the external power supply (M8023A) or to the Battery Extension (865297).

CAUTION

Do not use a monitor with an M1006A pressure module as an additional monitor for your patient. This may cause interference on the respiration or invasive pressure measurements.

You can measure pressure using an X1 or X2 Multi-Measurement Module (MMS), one of the MMS extensions or the pressure plug-in module - labeled as PRESS. With the plug-in module you may see a wave channel before the pressure cable is plugged in - with the MMS this will not be the case.

Setting up the Pressure Measurement

- 1 Plug in the pressure cable.
 - 2 Prepare the flush solution.
 - 3 Flush the system to exhaust all air from the tubing. Ensure that the transducer and stopcocks are free of air bubbles.
-

WARNING

If air bubbles appear in the tubing system, flush the system with the infusion solution again. Air bubbles may lead to a wrong pressure reading.

- 4 Connect the pressure line to the patient catheter.
- 5 If you are using an infusion pressure cuff with the pressure line, attach the pressure cuff to the fluid to be infused. Inflate it according to your standard hospital procedure, then start the infusion.
- 6 Position the transducer so that it is level with the heart, approximately at the level of the midaxillary line.

WARNING

If measuring intracranial pressure (ICP, IC1 or IC2) with a sitting patient, level the transducer with the top of the patient's ear. Incorrect leveling may give incorrect values.

Selecting a Pressure for Monitoring

Tell the monitor the source of the pressure you want to monitor by selecting an appropriate pressure label. The label is a unique identifier for each type of pressure. When you choose a label, the monitor uses that label's stored settings, for example color, wave scale and alarm settings. The label also determines which algorithm is used to process the pressure signal, so an incorrect label can lead to incorrect pressure values.

- 1 In the **Setup <Press Label>** menu, select **Label**.
- 2 Select the appropriate label from the list.

Label	Description
ABP	Arterial blood pressure
ART	Arterial blood pressure (alternative)
Ao	Aortic pressure
CVP	Central venous pressure
ICP	Intracranial pressure
LAP	Left atrial pressure
P	Non-specific pressure label
PAP	Pulmonary artery pressure
RAP	Right atrial pressure
UAP	Umbilical arterial pressure
UVP	Umbilical venous pressure

Extended Pressure Label Set

The following additional labels are available if **Label Set** is set to **Full**. This setting can only be changed in Configuration Mode.

Note that if your monitor is connected to an Information Center, the additional labels in the extended label set may not be correctly displayed. See the Configuration Guide for your monitor for more information.

Label	Description
BAP	Brachial arterial pressure
FAP	Femoral arterial pressure
IC1, IC2	Alternative intracranial pressures
P1, P2, P3, P4	Alternative non-specific pressure labels

Zeroing the Pressure Transducer

To avoid inaccurate pressure readings, the monitor requires a valid zero. Zero the transducer in accordance with your hospital policy. You must perform a zero:

- when you use a new transducer or tubing
- every time you reconnect the transducer cable to the monitor

if you think the monitor's pressure readings are not correct.

When using a pressure module, the zero information is stored in the module. When a pressure module, with the transducer connected, is plugged into the monitor, the monitor will use the Zero stored in the module.

Zeroing ICP (or IC1/IC2)

Your hospital guidelines may require you to zero the ICP transducer less frequently than other transducers, due to the need for aseptic conditions. When you zero an ICP transducer, the zero values are automatically stored and you will not be prompted to repeat the zero procedure.

If you want to simultaneously zero all pressures except ICP, disconnect the ICP transducer from the Multi-Measurement module or pressure module while zeroing. Reconnecting the transducer recalls the stored values.

WARNING

If you select the label ICP (or IC1/IC2), the measurement device uses the most recently stored zero. Therefore, make sure you zeroed the transducer correctly in accordance with the transducer manufacturer's instructions and your hospital policy. When you use a transducer that you cannot rezero after placement, ensure that you keep the measuring device with the patient so that you are certain you have the correct zero data for this patient.

Determining a Pressure's Most Recent Zero

The monitor displays the most recent zero on the status line. If this has "timed-out" after you have performed a zero, redisplay the information in the status line by entering the pressure's setup menu.

Zeroing a Pressure Measurement

WARNING

Invasive pressure alarms (and pulse alarms, if derived from invasive pressure) are temporarily suppressed until 30 seconds after the transducer finishes zeroing.

- 1 Turn off the stopcock to the patient.
- 2 Vent the transducer to atmospheric pressure, to compensate for the static and atmospheric pressure exerted on the transducer.
- 3 In the setup menu for the pressure, select **Zero <Press Label>**.
- 4 When you see the message **<Press Label> zero done at <Date and Time>** on the status line, close the stopcock to atmospheric pressure, and open the stopcock to the patient.

CAUTION

When using high frequency ventilation, ensure that the tubing from the ventilator does not touch the arterial line, or connect with it indirectly, while zeroing the pressure. This could cause small pressure variations which can interfere with the zero procedure.

Using the Zero Hardkey

Pressing the Zero hardkey for two seconds on the M1006B Pressure module starts a zero for the pressure currently measured with the module.

Pressing the Zero hardkey for two seconds on the M3001A Multi-Measurement module zeros the pressure being measured by the Multi-Measurement module **and** the pressures from any connected MMS extensions.

Zeroing All Pressures Simultaneously

WARNING

Before zeroing all pressures, make sure that **all** pressure transducers are vented to atmospheric pressure.

If you are measuring pressures with more than one measuring device, using the **Zero Press** SmartKey to initiate the zeroing calls up a list of all active pressures. Select the pressure you want to zero or select **All Press** to zero all pressures simultaneously.

Troubleshooting the Zero

The status line lists the probable cause of an unsuccessful zero:

Message	Corrective Action
unable to zero – equipment malfunction	The hardware is faulty. Contact your service personnel.
unable to zero – excessive offset	Make sure the transducer is vented to air and try again. If this fails, the hardware may be faulty. Replace the adapter cable and try again.
unable to zero – unstable signal	If it fails, replace the transducer and try again. If it still fails, contact your service personnel.
unable to zero – no transducer	Make sure that the transducer is connected and try again. If this fails, exchange the adapter cable and try again. If this fails, exchange the transducer.
unable to zero – pulsatile pressure	Make sure that the transducer is vented to air, not to the patient, and try again.
unable to zero – timed out	Try pressing the Zero hardkey or Zero <Press Label> key again. If this fails, replace the transducer and adapter cable and contact your service personnel.
Switch on first	Pressure measurement is switched off. To switch it on, in the Setup <Press Label> menu, select the pressure's label.

Adjusting the Calibration Factor

Each time you use a reusable transducer, compare the calibration factor written on your transducer with the calibration factor shown on the monitor. To ensure accurate measurement, they must be the same.

- 1 In the **Setup <Press Label>** menu, select **Cal. Factor**.
If the value here does **not** match that on the transducer, select the corresponding value from the list now in accordance with your hospital's procedure.
- 2 To confirm you want to use the new calibration factor, select the **Confirm** pop-up key.

Displaying a Mean Pressure Value Only

Use this when you want to see only the mean pressure.

In the pressure's setup menu, select **Mean only**. Toggle between **On** to display mean pressure value only, and **Off** to display all pressure values (systolic, diastolic and mean).

Changing the Pressure Wave Scale

- 1 Select the label of the pressure wave whose scale you want to set to enter the **Setup <Press Label>** menu.
- 2 In the **Setup <Press Label>** menu, (for example **ABP**) select **Scale**.
- 3 Select a value from the pop-up list:
 - a positive value sets the top gridline. The bottom gridline is set at zero.
 - a negative value sets the bottom gridline. The middle gridline is set at zero.

Optimizing the Waveform

In the **Setup <Press Label>** menu, select **Optimum Scale** to let the monitor select the best minimum and maximum scales for the current wave.

Using the Wave Cursor

When the pressure wave is selected, you can display a cursor in the wave. It appears as a white horizontal line in the wave. Using the pop-up keys you can move the cursor up or down to the required position and store the corresponding value. The cursor value can be stored

- as a systolic, diastolic or mean pressure value,
- as an IAP (intra-abdominal pressure) value - for the waves P, P1 to P8, if IAP is configured as a measurement which can be manually entered
- as a PAWP value - if the pressure wave is a PAP wave

The stored value appears in the trend database as a manually entered value.

To display and position the cursor

- 1 Select the pressure wave.
- 2 Select **Activate Cursor**.
- 3 Use the pop-up arrow keys to position the cursor.

Using the pop-up keys you can also change the scale or the speed for the wave, freeze the wave or start a printout or recording.

Non-Physiological Artifact Suppression

Some clinical procedures may affect blood pressure, for example, a flush procedure or a blood sample. Your monitor may be configured to suppress these non-physiological artifacts for a specified duration (**Artifact Suppr.** is configured to **30 sec, 60 sec, or 90 sec**). During artifact suppression, the monitor shows the INOP message **<Press Label> Artifact**, and a question mark is shown beside the pressure numerics. Pressure alarms and the **<Press Label> No Pulse INOP** are suppressed during the configured period. The CPP alarms are not suppressed.

Choosing the Pressure Alarm Source

WARNING

Make sure you set alarm limits for the correct label. The alarm limits you set are stored for that particular label only. Changing the label may change the alarm limits.

You can monitor for alarm conditions in systolic, diastolic and mean pressure, either singly or in parallel. Only one alarm is given at a time, in this order of priority: mean, systolic, diastolic.

In the **Setup <Press Label>** menu, select **Alarms from** and choose the source.

Menu option	Pressure value monitored
Sys.	systolic
Dia.	diastolic
Mean	mean
Sys & Dia	systolic and diastolic in parallel
Dia & Mean	diastolic and mean in parallel
Sys & Mean	systolic and mean in parallel
Sys&Dia&Mean	all three pressures in parallel

Select and set the **High Limit** and **Low Limit** for the pressure(s) you have selected.

Extreme Alarm Limits for Pressure

The extreme pressure alarms, Extreme High and Extreme Low, can be made available for your monitor in Configuration Mode and are additional to the standard High and Low limit alarms. They are generated by the active pressure alarm source, and are setup in Configuration Mode by adding a set value (the Δ value) to the high and low alarm limits. This value can be set for each pressure label individually.

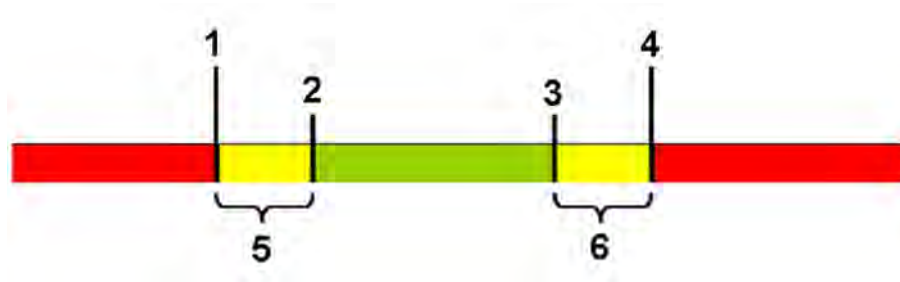

- 1 Extreme Low Limit
- 2 Low Limit
- 3 High Limit
- 4 Extreme High Limit
- 5 Δ Extreme Low
- 6 Δ Extreme High

You need to know which values have been configured for your monitor. Changing the high and low alarm limits automatically changes the extreme alarm limits within the allowed range.

- To see the extreme pressure alarms set for your monitor, in the **Setup <Press Label>** menu, see the menu items **Δ Extreme High** and **Δ Extreme Low**.

The extreme pressure alarms are high priority, red alarms, marked ******* in the alarm message.

Calibrating Reusable Transducer CPJ840J6

Depending on your monitor's configuration, you may be able to perform a calibration in monitoring mode. Perform a mercury calibration when you use a new transducer, and at regular intervals according to your hospital policy. You require:

- standard sphygmomanometer.
- sterile 10cc syringe with heparinised solution.
- 3-way stopcock.
- approximately 25 cm of tubing.

Making the Pressure Calibration

WARNING

Never perform the invasive pressure calibration while a patient is being monitored.

- 1 Zero the transducer.
- 2 Connect the syringe and manometer.
 - a. Attach the tubing to the manometer.
 - b. Connect the 3-way stopcock to the stopcock that is not connected to the patient catheter when you measure a patient.
 - c. Attach the syringe to one port and the manometer tubing to the other port.

- d. Open the port to the manometer.

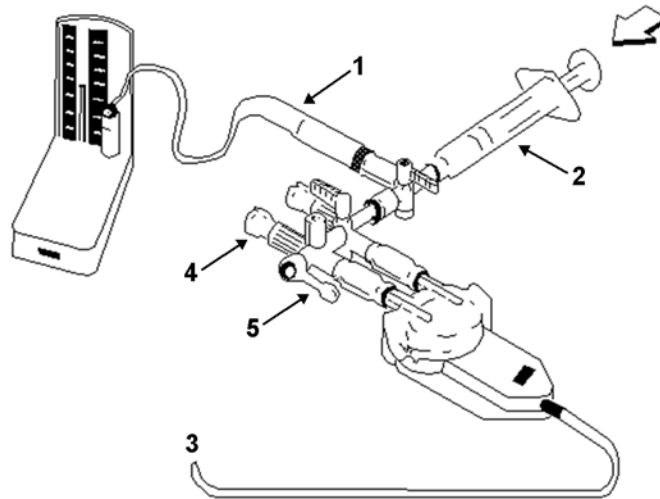

- 1 Tubing to manometer
- 2 Syringe with heparinised solution
- 3 To pressure connector on monitor
- 4 Patient connection stoppered
- 5 Off

- 3 Move the syringe barrel in and raise the mercury to 200 mmHg (30 kPa). 200 mmHg is the recommended calibration pressure.
- 4 In the **Setup <Press Label>** menu, select **Cal. Press**.
- 5 Select the calibration pressure from the list, for example 200 mmHg.
- 6 Select **Confirm** to recalculate the calibration factor using the applied pressure.
- 7 When the monitor displays **<Press Label> mercury calibr. done at <Date and Time>**, remove the manometer tubing, syringe and extra stopcock. We recommend you replace the transducer dome and tubing with sterile ones.
- 8 Label the transducer with the calibration factor shown in the **Cal. Factor** field in the pressure's setup menu.
- 9 Reconnect the patient and start measuring again.

Troubleshooting the Pressure Calibration

The status line lists the probable cause of an unsuccessful calibration.

Message	Corrective Action
unable to calibrate – equipment malfunction	Contact your service department. The pressure hardware is faulty.
unable to calibrate – out of range	Make sure that you have selected the value for Cal. Press that you are applying to the transducer, and repeat the calibration.
unable to calibrate – no transducer	Make sure that the transducer is connected and try again.
unable to calibrate – unstable signal	Make sure there are no disturbances to the transducer, and repeat the calibration.

Message	Corrective Action
unable to calibrate – perform zero first	No valid zero. Zero the transducer.

Calculating Cerebral Perfusion Pressure

The monitor can calculate the difference between mean arterial pressure and the intracranial pressure. The difference is labeled CPP.

- 1 In the **Main Setup** menu, select **Measurements**.
- 2 Select **CPP**.
- 3 In the **Setup CPP** menu, select which arterial pressure source should be used in the calculation.

Calculating Pulse Pressure Variation

Note: Pulse Pressure Variation can be calculated in two different ways on this monitor - directly from the pressure measurement or in conjunction with the CCO measurement. Refer to the Cardiac Output chapter for information on PPV from CCO. Only one PPV can be active at a time.

Pulse Pressure Variation (PPV) is calculated from beat-to-beat arterial pressure values. Pulse pressure is the difference between the systolic and the diastolic pressure values for a single beat. Pulse pressure variation is defined as the maximal pulse pressure less the minimum pulse pressure divided by the average of the two. The average variation in pulse pressure is calculated over periods of 32 seconds.

WARNING

- This monitor can calculate PPV from beat-to-beat values of any arterial pulsatile pressure. The circumstances under which the calculation of a PPV value is clinically meaningful, appropriate and reliable must be determined by a physician.
- The clinical value of the derived PPV information must be determined by a physician. According to recent scientific literature, the clinical relevance of PPV information is restricted to sedated patients receiving controlled mechanical ventilation and mainly free from cardiac arrhythmia.
- PPV calculation may lead to inaccurate values in the following situations:
 - at respiration rates below 8 rpm
 - during ventilation with tidal volumes lower than 8 ml/kg
 - for patients with acute right ventricular dysfunction ("cor pulmonale").
- The PPV measurement has been validated only for adult patients

To select an arterial pressure as PPV source:

- 1 In the **Main Setup** menu, select **Measurements**.
- 2 In the **Setup PPV** menu, select **ABP, ART, Ao, BAP, P** or **FAP** as the arterial pressure source.

CAUTION

Older Multi-Measurement modules cannot supply a beat-to-beat arterial pressure value. In this case the monitor shows a **No PPV from MMS** or **No PPV from FMS INOP**.

Measuring IAP

There are two methods to store IAP measurement readings in the monitor: with manual entry or using a pressure waveform.

NOTE

For both methods, to be able to use the label IAP, it must be made available for manual entry in Configuration Mode. For more details on manually entered measurements, see “Entering Measurements Manually” on page 46.

Manual Entry

This method uses a reading from an independent IAP measurement device, for example a bladder manometer; the user manually transcribes the IAP reading to the monitor.

To manually enter the measured IAP value:

- 1 Select the IAP numeric on the screen.
- 2 Enter the IAP value and select **Enter** using the numeric keypad.
- 3 If you need to change date and time, select **Date/Time**. The default is always the current date and time. Select **Enter** to confirm.
- 4 Select **Save**.

Using a Pressure Waveform

This method uses an electronic reading from a pressure transducer connected to the monitor. The pressure transducer usually acquires the IAP from a dedicated IAP measurement device.

To enter the IAP using a connected IAP measurement device:

- 1 Assign the pressure label P (or P1...P8) to the pressure channel connected to the IAP transducer.
- 2 Zero the transducer as described in “Zeroing a Pressure Measurement” on page 215.
- 3 Perform the IAP measurement according to the instructions given by the manufacturer of the IAP measurement device.
- 4 On the monitor screen, when the IAP pressure has stabilized, select the pressure waveform and select **Activate Cursor**.
- 5 Use the arrow up/down keys to move the wave cursor to an area of the waveform that reflects the correct pressure. See “Using the Wave Cursor” on page 217 for details.
- 6 Select **Save as IAP**. This will store the IAP pressure value under the cursor in the monitor’s database and display it on the monitor screen.

Measuring Pulmonary Artery Wedge Pressure

Pulmonary Artery Wedge Pressure (PAWP) values, used to assess cardiac function, are affected by:

- Fluid status
- Myocardial contractility
- Valve and pulmonary circulation integrity

Obtain the measurement by introducing a balloon-tipped pulmonary artery flotation catheter into the pulmonary artery. When the catheter is in one of the smaller pulmonary arteries, the inflated balloon

occludes the artery allowing the monitor to record changes in the intrathoracic pressures that occur throughout the respiration cycle. The pulmonary wedge pressure is the left ventricular end diastolic pressure (preload).

The most accurate PAWP values are obtained at the end of the respiration cycle when the intrathoracic pressure is fairly constant. You can use the respiration waveform as a reference when assessing the PAWP waveform, to ensure constant measurement timing relative to the respiratory cycle. The monitor displays the PAWP value for up to 24 hours or until you admit a new patient.

WARNING

The pressure receptor in the catheter records pressure changes that occur only in front of the occlusion. Even though the catheter tip is in the pulmonary artery, the receptor records pressure changes transmitted back through the pulmonary circulation from the left side of the heart.

While performing the wedge procedure, the monitor switches off the pressure alarms for pulmonary artery pressure (PAP).

Due to a slight measurement delay, you should not use sidestream CO₂ as a direct reference for determining the end expiratory point in the pressure curve.

To start the Wedge procedure,

- 1 In the **Main Setup** menu, select **Wedge** to display the wedge procedure window.
- 2 Prepare and check the pressure line according to your hospital policy.
- 3 Use the **Reference Wave 1** and **Reference Wave 2** pop-up keys to select any ECG or respiratory wave as reference waves.
- 4 Select **Change Speed** if you want to change the speed of the displayed wave. The speed can also be changed in the screen for editing the wedge.
- 5 Select **Change Scale** to change the wave scale of the PAP. The same scale will be used in the screen for editing the wedge. If the setting **Optimum Scale** is used, the wave scale will be optimized when a wedging waveform is recognized and will revert to the previous scale when the wedge procedure window is closed.
- 6 Inflate the balloon when the monitor prompts you: **Ready for balloon inflation**. The waveform changes from the PAP to the PAWP wave. The measurement takes approximately 12 seconds. On completion, the monitor stores the PAWP waveform display and prompts you to deflate the balloon. If the monitor cannot detect a wedging waveform you must use **Store Trace** to store the wedge and two reference waves manually.
- 7 Deflate the balloon when the monitor prompts you: **Ready for balloon deflation** and verify that the waveform returns to pulmonary artery shape.
- 8 If you need to start a new measurement, select **Restart Wedge**.

Editing the Wedge

- 1 Select the **Edit Wedge** pop-up key to see the stored waveforms.
- 2 The monitor displays a cursor in the waveform at the PAWP mean value. It also displays any previously stored value and the time it was stored.
- 3 Select **Change Speed** if you want to change the speed (resolution) of the displayed wave.
- 4 Move the cursors up, down, right and left to set them on the correct wedge position.

- 5 Select **Store Wedge** to store the PAWP value.
- 6 Select **Print Wedge** to print the PAWP waveform and any reference waves or **Record Wedge** to record them. While recording or printing, you cannot perform any more Wedge tasks.

WARNING

Prolonged inflation can cause pulmonary hemorrhage, infarction or both. Inflate the balloon for the minimum time necessary to get an accurate measurement.

If the pulmonary artery flotation catheter drifts into the wedge position without inflation of the balloon, the pulmonary artery pressure waveform assumes a wedged appearance. Take appropriate action, in accordance with standard procedures, to correct the situation.

If the PAWP (mean) is greater than the PAP (systolic), deflate the balloon and report the incident in accordance with hospital policy, because the pulmonary artery could be accidentally ruptured, and the wedge value derived will not reflect the patient's hemodynamic state, but will merely reflect the pressure in the catheter or balloon.

Identifying the Pressure Analog Output Connector

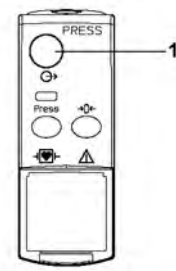

- 1 Analog output (module M1006B, option C01 only)

Monitoring Cardiac Output

The Cardiac Output (C.O.) measurement invasively measures cardiac output and other hemodynamic parameters using a technique called thermodilution. This can be used to determine the flow rate of a system by introducing a cold solution into the system and measuring the resulting drop in temperature at a downstream site. The temperature change is displayed as a curve in the C.O. procedure window, and the monitor calculates the C.O. value from this curve. The C.O. value is inversely proportional to the area under the curve. As cardiac output varies continuously, a series of measurements must be carried out to achieve a reliable C.O. average value. Always use the average of multiple thermodilution measurements for therapy decisions.

The measurements can be carried out using the right heart thermodilution method or the PiCCO method (transpulmonary thermodilution).

- The right heart method is available with
 - C.O. module M1012A - labeled as C.O., standard and option #C10 - labeled as CCO/C.O.
 - M3012A Hemodynamic Measurement Extension Module, options #C05 and #C10
 - M3014A Capnography Measurement Extension Module, option #C05 and #C10
- The PiCCO method is available with
 - C.O. module M1012A - labeled as C.O., option #C10 - labeled as CCO/C.O.
 - M3012A Hemodynamic Measurement Extension Module, option #C10
 - M3014A Capnography Measurement Extension Module, option #C10

The PiCCO method additionally lets you measure Continuous Cardiac Output (CCO) by performing pulse contour analysis on the blood pressure waveform.

Hemodynamic Parameters

This table illustrates the hemodynamic parameters available with each method, whether they are measured continuously, and whether they can be shown on the monitor's main screen or in the **Hemodynamic Calculations** window.

Measured and Calculated Hemodynamic Parameters and Indexes	PiCCO Method (Transpulmonary Thermodilution)			Right Heart Thermodilution		
	Continuous?	Main Screen	HemoCalc Window	Continuous?	Main Screen	HemoCalc Window
Blood Temperature (T _{blood})	Yes	Yes	No	Yes	Yes	No
C.O./C.I.: Cardiac Output	No	Yes	Yes	No	Yes	Yes
CCO/CCI: Continuous Cardiac Output	Yes	Yes	Yes (in the C.O. field)	Not available		
SVR/SVRI: Systemic Vascular Resistance	Both	Yes	Yes	No	No	Yes
SV/SI: Stroke Volume/SV Index	Both	Yes	Yes	No	No	Yes
SVV: Stroke Volume Variation	Yes	Yes	Yes	Not available		
*dPmax: Left Ventricular Contractility Index	Yes	Yes	Yes	Not available		
CFI: Cardiac Function Index	No	Yes	Yes	Not available		
PPV: Pulse Pressure Variation	Yes	Yes	Yes	Not available		
ITBV/ITBVI: Intrathoracic Blood Volume	No	Yes	Yes	Not available		
EVLW/EVLWI: Extravascular Lung Water	No	Yes	Yes	Not available		
GEDV/GEDVI: Global End-Diastolic Volume	No	Yes	Yes	Not available		
*PVPI: Pulmonary Vascular Permeability Index	No	Yes	Yes	Not available		
*GEF: Global Ejection Fraction	No	Yes	Yes	Not available		
*RLShnt: Right-Left-Shunt Fraction	No	No	No	Not available		
PVR/PVRI: Pulmonary Vascular Resistance	Not available			No	No	Yes
LCW/LCWI: Left Cardiac Work	No	No	Yes	No	No	Yes
RCW/RCWI: Right Cardiac Work	Not available			No	No	Yes
RVSU/RVSWI: Right Ventricular Stroke Work	Not available			No	No	Yes

* currently not available in the U.S.A. and territories relying on FDA market clearance.

NOTE

EVLWI is calculated using Ideal Body Weight (IBW). ITBVI and GEDVI are calculated using Ideal Body Surface Area (IBSA). IBW and IBSA are based on the patient category, gender and height that you have entered for the patient.

Using the C.O. Procedure Window

The procedure window displays up to six trials (measurement curves) with the trial number and the C.O. value under the thermodilution curve. When you open the window, a line of pop-up keys automatically appears to let you carry out C.O.-related tasks. This example shows the procedure window for the transpulmonary (PiCCO) Method. The window may be configured to look slightly different on your monitor.

To open the procedure window,

- Select **Cardiac Output** in the **Setup C.O.** or **Setup CCO** menu, or
- Select the **Cardiac Output** SmartKey on the Screen, if configured, or
- Press the START hardkey on the front of the C.O. plug-in module, if available, or
- Press a remote start switch, if you are using one.

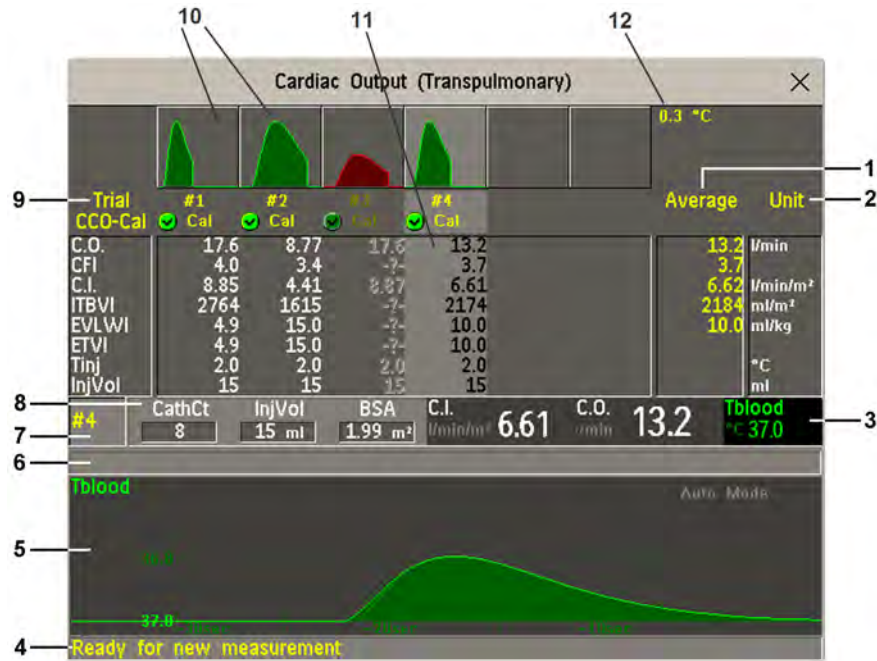

- 1 **Average** - column of averaged values
- 2 **Unit** column
- 3 Continuously measured numeric
- 4 Prompt message field
- 5 Thermodilution curve of current trial
- 6 Curve alert message field
- 7 Current trial number
- 8 Setup information
- 9 **Trial** numbers for the trial curves
- 10 Trial curves
- 11 Results table of current trial
- 12 Trial curve scale

- To change the measurement parameters shown in the results table of the procedure window, select the **Table Contents** pop-up key and choose from the list of available parameters.
- To view the currently-used temperature unit, see the "grayed-out" setting **Temperature Unit** in the **Setup C.O.** menu. This setting can only be changed in Configuration Mode.
- The Cardiac Output screen element may be configured to display permanently on a specially designed Screen. Selecting the screen element opens the cardiac output pop-up keys.

Accessing the Setup C.O. and Setup CCO Menus

C.O. settings can be changed in the **Setup C.O.** menu. To access this menu,

- press the C.O. hard key on the C.O. module, or
- select any of the discontinuous C.O. numerics (for example, C.O., C.I.) on the screen.

CCO/CCI settings can be changed in the **Setup CCO** menu. To access this menu,

- select any of the continuously measured hemodynamic numerics (CCO, CCI.) on the screen.

Entering the HemoCalc Window

From the procedure window, select the pop-up key **Hemo Calc** to open the **Hemo Calculations** window.

Measuring C. O. Using the PiCCO Method

The PiCCO method combines transpulmonary thermodilution and pulse contour analysis on the blood pressure waveform. A fluid with a known volume and temperature is injected into the right atrium through a CVP catheter. The injectate bolus mixes with the blood in the heart and the change in blood temperature is measured with a thermistor at the distal end of an arterial catheter placed in one of the bigger systemic arteries, for example, the femoral or the axillary artery.

The PiCCO Method requires a pressure measurement made using either the M1006B Pressure module, or a M3001A/M3002A MMS, or a measurement extension module M3015A, M3014A, or M3012A. (A pressure from an external device may not be used.) You will also need a conventional central venous (CVP) line and an arterial catheter from PULSION Medical Systems. You must use the approved catheters and puncture locations.

Measuring Continuous Cardiac Output

Every time C.O. is measured with the PiCCO method, the monitor uses this C.O. value and the result of the pulse contour analysis to calculate a patient-specific calibration factor. The monitor uses this value to compute CCO and the other continuous hemodynamic parameters. CCO values are calculated on a beat-to-beat basis and then averaged over a 12-second time frame. The calculated values are displayed as numerics on the monitor screen.

Measuring Systemic Vascular Resistance

The monitor uses CCO, an arterial pressure, and CVP to calculate a continuous SVR value. If a continuously measured CVP value is not available, the monitor uses a preset, static CVP value to calculate the SVR (you will see the INOP message **SVR Set CVP Used**). If the BSA is available, the monitor uses the CCI to calculate the SVRI. A CCO or CCI from an external device can also be used for the SVR/SVRI calculation.

SVR/SVRI settings can be changed in the corresponding setup menu. To enter the menu, select **Main Setup** then **Measurements** followed by **SVR** or **SVRI**.

To display a **SVR/SVRI** numeric on the Screen, select any numeric, then select **Change Numeric** and select **SVR** or **SVRI** from the list of available numerics.

Measuring Pulse Pressure Variation

Note: Pulse Pressure Variation can be calculated in two different ways on this monitor - in conjunction with CCO or directly from the pressure measurement. Refer to the Invasive Pressure chapter for information on PPV from pressure. Only one PPV can be active at a time.

Pulse Pressure Variation (PPV) is calculated from beat-to-beat arterial pressure values. Pulse pressure is the difference between the systolic and the diastolic pressure values for a single beat. Pulse pressure variation is defined as the maximal pressure less the minimum pressure divided by the average of these two pressures.

WARNING

- The monitor calculates PPV from beat-to-beat values of the arterial pressure selected for CCO. The circumstances under which the calculation of a PPV value is clinically meaningful, appropriate and reliable must be determined by a physician.
 - The clinical value of the derived PPV information must be determined by a physician. According to recent scientific literature, the clinical relevance of PPV information is restricted to sedated patients receiving controlled mechanical ventilation and mainly free from cardiac arrhythmia.
 - PPV calculation may lead to inaccurate values in the following situations:
 - at respiration rates below 8 rpm
 - during ventilation with tidal volumes lower than 8 ml/kg
 - for patients with acute right ventricular dysfunction ("cor pulmonale").
 - The PPV measurement has been validated only for adult patients
-

Setting Up the PiCCO C.O. Measurement

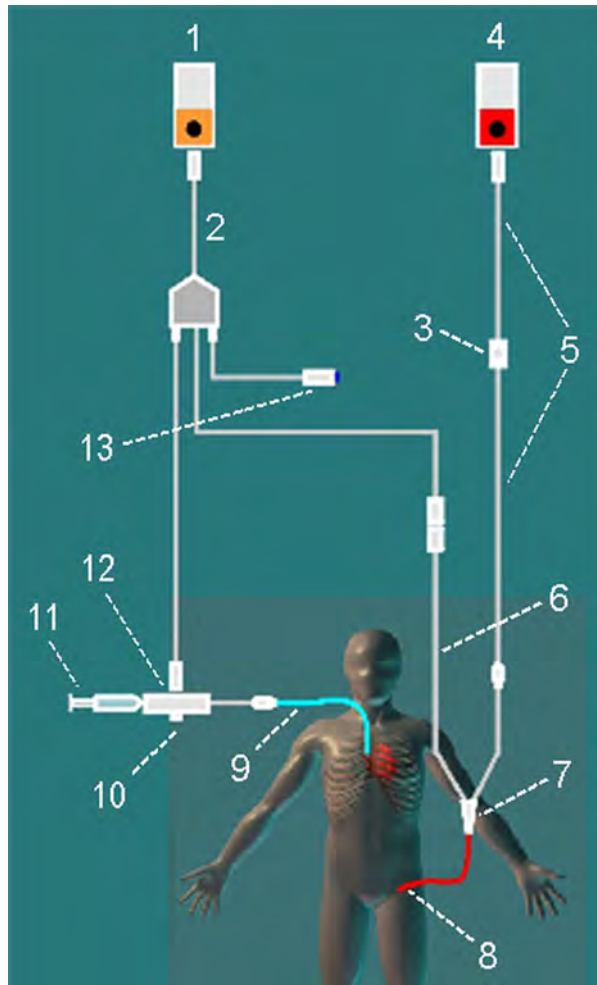

- 1 C.O. Module
- 2 C.O. Interface Cable
- 3 PULSION Pressure Transducer
- 4 Press Module
- 5 Pressure Adapter Cable
- 6 Thermistor Connection Cable
- 7 Thermistor Connection
- 8 PULSION Arterial Catheter
- 9 CVP Line
- 10 Injectate Temperature Probe Housing
- 11 Injectate Syringe
- 12 Injectate Temperature Probe
- 13 Remote Switch

- 1 Set up the arterial line using the arterial catheter (transpulmonary catheter) and the transducer kit from PULSION Medical Systems. It must be placed in one of the bigger systemic arteries, for example, the femoral or the axillary artery. You must use the approved catheters and puncture locations.
- 2 Set up the central venous line.
- 3 Connect the injectate temperature probe housing to the venous line.
- 4 Plug the C.O. interface cable into the C.O. module or measurement extension module and connect the following devices to the C.O. interface cable:
 - Injectate temperature probe
 - Thermistor connector
 - Remote start switch (if used).

Follow your hospital standards to avoid unintentional extraction of the C.O. catheter. Secure the cable using the mounting clip shipped with each C.O. interface cable. You may also find it helpful to loop the C.O. interface cable, tape the loop, and attach it to the undersheet of the patient's bed using a safety pin.

- 5 If you are measuring CCO, set up the pressure measurement now. The CCO measurement requires a minimally dampened invasive pressure setup. You must ensure that there are no air bubbles in the pressure line or dome and use only specified accessories.
- 6 Check that the correct measurement method is selected.
If a catheter is already connected to the Cardiac Output Interface Cable, the monitor automatically recognizes the method used. If not, in the **Setup C.O.** menu, select **Method** and then select **Transpulmny**.
- 7 Check that you are using the correct probe - the M1646. This is the only probe supported for use; it can be used with room temperature injectate or with cold injectate.
- 8 Check that the correct arterial catheter constant is selected.
If the catheter is recognized by the monitor, the catheter constant is automatically displayed and cannot be changed manually. If it is not recognized, in the procedure window, select **CathCt** and use the pop-up keypad to enter the correct value. The catheter constant is usually written either on the catheter or on the catheter packaging.
- 9 Make sure that the injectate volume setting matches the injectate volume you will use. To change the volume, in the procedure window, select **InjVol** and select the correct injectate volume from the pop-up list.
If there is a problem with the volume or temperature you have chosen, the monitor will issue a curve alert message to inform you of this.
- 10 If you are measuring CCO or CCI, check that the correct pressure source is selected in the **Setup CCO** menu. The pressure label under **CCO from** must match the pressure measured with the arterial catheter. To change the pressure source, select **CCO from** to call up a list of available pressure labels and select the correct label.
- 11 If you are measuring CCO or CCI, verify that the correct alarm source is selected in the menu item **Alarms from**. To change the alarm source, select **Alarms from** and choose either **CCO** or **CCI**.

Performing PiCCO C.O. Measurements

Always wait for the monitor to indicate readiness for the next step before proceeding.

If you are measuring CCO, all measurements should be conducted within 15 minutes. Older measurements "expire" for CCO calibration.

- 1 Enter the procedure window.
- 2 When you see the message **Ready for new measurement**, start the measurement by selecting the pop-up key **Start C.O.** or pressing the Start hardkey on the C.O. module, or pressing the remote start switch. If the measuring mode is set to **Auto** the **Start C.O.** key will also enable the automatic start of consecutive measurements.
- 3 When you hear the ready tone and see the message **Stable baseline, inject now!**, inject the solution into the CVP catheter.
At the end of the measurement the thermodilution curve, cardiac output, index values, ITBV and EVLW values and any curve alerts are displayed and a message will appear **Wait before starting new measurement** or in **Auto** mode **Prepare for next injection or press Stop**.
- 4 When you see the **Stable baseline, inject now!** message, repeat the procedure until you have completed the measurements you want to perform. You can perform a maximum of 6 measurements before editing. If you perform more than 6 measurements without rejecting any, the oldest will automatically be deleted when a 7th curve is stored.

Editing PiCCO C.O. Measurements

It is important to identify and reject erroneous trials, as the monitor uses all the measurement trial values you do not reject to calculate the averaged cardiac output.

- 1 Review the trials. Irregular trials or trials marked with a "?" should be reviewed carefully. Consider the similarity of the values and the shape of the C.O. curve. A normal C.O. curve has one smooth peak and returns to the temperature baseline level after the peak.
- 2 Reject unsatisfactory trials: use the **Select Trial** pop-up key to move between trials, then select the **Accept Reject** pop-up key to accept or reject trials. If you are using a touch screen you can accept or reject trials directly by tipping on the trial curve. Discard conspicuously different values. The background of rejected trials is red and the background of accepted trials is green. The monitor recalculates the average values after you reject or accept trials.

If all values are different from each other, there may be true hemodynamic instability caused, for example, by severe cardiac arrhythmia.

Saving and Calibrating PiCCO C.O. Measurements

When you have finished editing the trials, you must save the results. This closes the measurement series, sends the average C.O. numeric to be displayed on the main screen, and stores the averaged values in the trends and calculations databases.

Before the monitor can calculate CCO, you must calibrate the measurement. You should also calibrate CCO every eight hours, or if the hemodynamic condition of the patient changes consistently in the same direction over 15 minutes, or if there are large or sudden changes in the patient's condition.

The monitor only uses C.O. measurements from within the last 15 minutes for calibrating CCO.

To save and calibrate,

- In the procedure window, select the pop-up key **SaveC.O. &Cal CCO** to use the averaged C.O. value to calibrate Continuous Cardiac Output (CCO).

Your monitor may be configured to have two separate pop-up keys, **Save C.O.** and **Cal CCO**, instead of the combined **SaveC.O. &Cal CCO**.

WARNING

CCO calibration is patient-specific. When the C.O. module or measurement extension module is plugged in after the patient has changed, make sure that the correct CCO calibration is used. When in doubt perform a new CCO calibration first.

CCO Calibration Status Indicators

Each measurement trial is tagged with a calibration status indicator next to its trial number. Reflecting the quality of the pressure signal during the thermodilution measurement, this tag indicates each trial's validity to be used in a CCO calibration.

For a trial to be eligible for calibration, the pressure signal must be continuously available and undisturbed starting 30 seconds before the first C.O. measurement of the series. Do not zero the pressure measurement, change the pressure label, or disturb the pressure signal in any other way during this time.

Cal	A pressure signal for CCO was available during the measurement (valid for calibration)
------------	--

?Cal	A disturbed pressure signal for CCO was available during the measurement (valid for calibration)
N/A	No adequate pressure signal for CCO was available during the measurement (no valid calibration data)
Exp	This trial is more than 15 minutes older than the most recent trial and has expired for CCO calibration (no valid calibration data)

Measuring C.O. Using the Right Heart Thermodilution Method

In the right heart thermodilution method, a fluid of known volume and temperature is injected into the right atrium through the proximal port of a pulmonary artery (PA) (Swan-Ganz) catheter. The injectate bolus mixes with the blood in the right ventricle and the change in blood temperature is measured with a thermistor at the distal end of the catheter in the pulmonary artery.

Setting up RH C.O. Measurements

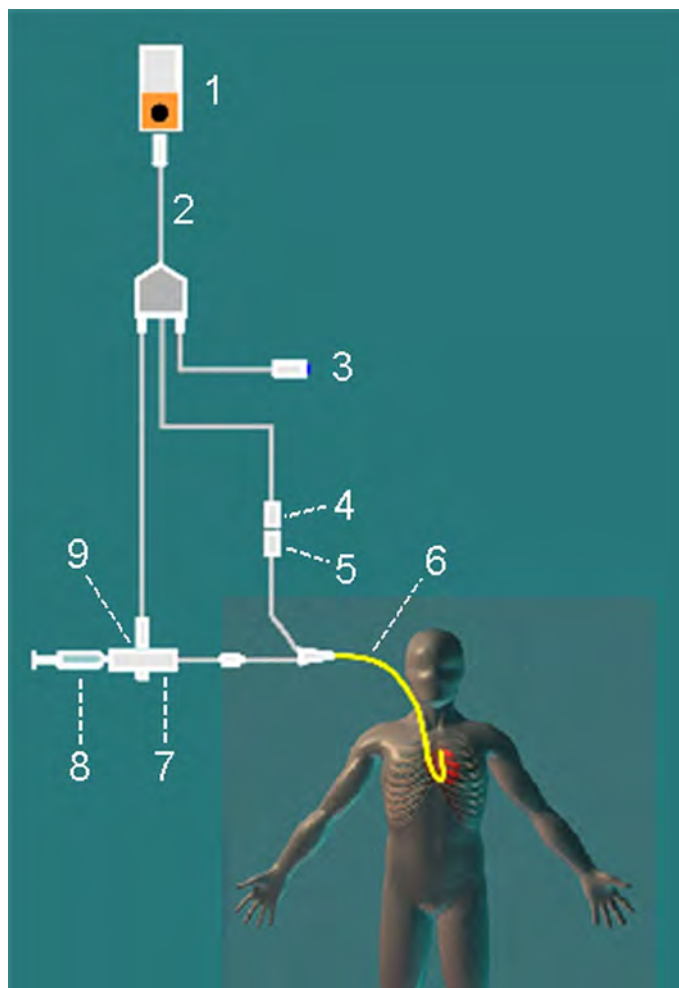

- 1 C.O. Module
- 2 C.O. Interface Cable
- 3 Remote Start Switch
- 4 Thermistor Connector
- 5 Thermistor Connection Cable
- 6 PA Catheter
- 7 Injectate Temperature Probe Housing
- 8 Injectate Syringe
- 9 Injectate Temperature Probe

- 1 Set up the PA line using a PA catheter.

- 2 Attach the injectate temperature probe housing to the PA line.
- 3 Plug the C.O. interface cable into the C.O. module or measurement extension module and connect the following devices into the C.O. interface cable:
 - injectate temperature probe
 - remote start switch (if used).

Follow your hospital standards to avoid unintentional extraction of the C.O. catheter. Secure the cable using the mounting clip shipped with each C.O. interface cable. You may also find it helpful to loop the C.O. interface cable, tape the loop, and attach it to the undersheet of the patient's bed using a safety pin.

- 4 Plug the thermistor connection cable of the PA catheter into the thermistor connector.
- 5 Connect the injectate temperature probe to the injectate temperature probe housing.
- 6 Check that the correct measurement method is selected.

If a catheter is already connected to the Cardiac Output Interface Cable, the monitor automatically recognizes the method used. If not, in the **Setup C.O.** menu, select **Method** and then select **Right Heart**.

Ice-Bath Setup for RH Thermodilution C.O. Measurements

If you are using the flow-through method illustrated above, the injectate temperature is measured at the time of injection by the temperature probe in the injectate temperature probe housing.

If you are using the ice-bath setup, the injectate temperature probe and the injectate are both placed in an ice-bath and the probe measures the temperature of the contents of the ice bucket.

Setting the Computation Constant

Check that the correct **Computation Constant** is entered in the procedure window. This can be found in the documentation supplied with the catheter and is based on the injectate volume, injectate temperature and catheter type. To change the value, in the procedure window, select **Computation Constant** and use the pop-up keypad to enter the correct value.

Performing RH C.O. Measurements

- 1 Enter the procedure window.
- 2 When you see the message **Ready for new measurement**, select the pop-up key **Start C.O.**. If the measuring mode is set to **Auto** the **Start C.O.** key will also enable the automatic start of consecutive measurements.
- 3 When you hear a ready tone and see the message **Inject now!**, inject the solution into the right atrial port of the Swan-Ganz catheter. The optimal injection rate is 2.5 ml/second.
At the end of the measurement the thermodilution curve, cardiac output, index values and curve alerts (if necessary) are displayed and a message will appear **Wait before starting new measurement** or in **Auto** mode **Prepare for next injection or press Stop**.
- 4 When you see the **Inject now!** message, repeat the procedure until you have completed the measurements you want to perform. You can perform a maximum of six measurements before editing. If you perform more than six measurements without rejecting any, the oldest will automatically be deleted when a seventh curve is stored.

Editing and Saving RH C.O. Measurements

It is important to identify and reject erroneous measurements (called "trials"), as the monitor uses all the measurement trial values you do not reject to calculate the averaged cardiac output.

- 1 Review the trials. Irregular trials or trials marked with a "?" should be reviewed carefully. Consider the similarity of the values and the shape of the C.O. curve. A normal C.O. curve has one smooth peak and returns to the temperature baseline level after the peak.
- 2 Reject unsatisfactory trials: use the **Select Trial** pop-up key to move between trials, then select the **Accept Reject** pop-up key to accept or reject trials. If you are using a touch screen you can accept or reject trials directly by tipping on the trial curve. Discard conspicuously different values. The background of rejected trials is red and the background of accepted trials is green. The monitor recalculates the average values after you reject or accept trials.
If all values are different from each other, there may be true hemodynamic instability caused, for example, by severe cardiac arrhythmia.
- 3 Save average C.O. values. To close a measurement series, you must save the average values by selecting the pop-up key **Save C.O.**. This sends the average C.O. numeric to be displayed on the main screen, and stores the averaged values in the trends and calculations databases.

Documenting C.O. Measurements

You can document C.O. measurements on the default printer or recorder.

- 1 In the procedure window, select the pop-up key **Print/ Record**.
- 2 From the pop-up list, choose:
 - **Print Results** to print the contents of the procedure window
 - **Record Results** to record the contents of the procedure window
 - **Record Trial** to send an individual trial curve to the recorder.

C.O. Injectate Guidelines

The greater the injectate volume and the colder the temperature, the more accurate the measurement. Reduced injectate volume or higher injectate temperature may reduce the specified accuracy.

For adult patients, to ensure the greatest measurement accuracy, use a cold injectate (< 8°C) of 10 ml volume, if not contra-indicated by the patient's condition. Your choice of injectate volume should be based on the injectate temperature and the patient's cardiac output.

Guidelines for Right Heart Thermodilution C.O. Injectate

If you are using the right heart thermodilution method, the use of injectate with a temperature less than 8°C lower than the blood temperature may cause incorrect values for the thermodilution.

Guidelines for PiCCO C.O Injectate

If you are using the PiCCO method, the use of injectate with a temperature that is not at least 12°C lower than the blood temperature may cause incorrect values for the thermodilution and CCO calibration.

Injectate Volume, Patient Weight and ETVI Values (PiCCO Only)

When deciding on an injectate volume and temperature, you must consider your patient's Ideal Body Weight (IBW) and extra-vascular thermal volume index (ETVI). IBW is based on the patient category, gender and height that you have entered for the patient. The calculated IBW is displayed in the window that opens when you select the **InjVol** field.

High ETVI

The dilution of injectate is influenced by extravascular tissue and fluid. The accuracy of the PiCCO method may be reduced in patients with high extra-vascular thermal volume index (ETVI) values. Use the table below as a guide in selecting the correct injectate temperature. As shown in the table, if your patient has an ETVI > 10, you must use cold injectate.

Weight

Use the table below as a guide in choosing an injectate volume appropriate for the patient weight.

IBW	Cold Injectate		Room Temperature Injectate	
	ETVI < 10	ETVI ≥ 10	ETVI < 10	ETVI ≥ 10
< 3 kg	2 ml	2 ml	3 ml	Use cold injectate
< 10 kg	2 ml	3 ml	3 ml	
< 25 kg	3 ml	5 ml	5 ml	
< 50 kg	5 ml	10 ml	10 ml	
< 100 kg	10 ml	15 ml	15 ml	
≥ 100 kg	15 ml	20 ml	20 ml	

C.O./CCO Curve Alert Messages

After each measurement trial, the monitor analyzes the thermodilution curve. If the curve appears abnormal, a curve alert message appears in the procedure window. A question mark symbol ("?") may appear next to the cardiac output numeric if any of these messages appear. The curve alert messages are not error messages and do not necessarily mean that the measured values are invalid.

C.O./CCO Curve Alert Messages	Possible Causes
Tinj off scale	The Tinjectate is out of the range -1°C and 30°C. Cool down or heat up the injectate or change the injectate solution and repeat the measurement.

C.O./CCO Curve Alert Messages	Possible Causes
Noisy baseline	<p>A blood temperature baseline drift that could not be compensated was detected during the C.O. measurement. Possible causes are:</p> <ul style="list-style-type: none"> - Interference may be caused by a ventilator. - Interference may be caused by an infusion pump: infusions of significant volume through the central line should be paused at least 30 seconds before the first thermodilution measurement in a series and should not recommence until the measurement series is completed. - Do not administer injections through the central line during a measurement series. - Electrical devices in the vicinity can cause interference: check for infusion pumps connected to the central catheter, cables parallel to the thermodilution cable, electrocautery. Make sure all devices are properly grounded. - Wait until measurement results are displayed before moving the patient or catheter. - Close the stopcock to the injectate syringe after the injection. - Do not rinse the catheter during measurement, to avoid temperature fluctuations.
Temperature baseline drift	<p>May occur if patient is recovering from open heart surgery, or if patient was cooled down for surgery and is in the process of regaining normal body temperature when the measurement is made.</p>
Small signal, more indicator required	<p>The peak of the transpulmonary thermodilution curve was below 0.1°C. Increase injectate volume and/or lower injectate temperature.</p>
Injectate temperature too high	<p>The difference between the blood and injectate temperatures is too small. The calculated value for C.O. may not be accurate.</p>
High ETVI, use cold injectate or greater inj. volume	<p>The ETVI value is too high. The accuracy of the transpulmonary thermodilution measurement may be reduced. Increase injectate volume and/or lower injectate temperature following the guidelines given in the section “Guidelines for PiCCO C.O Injectate” on page 235.</p>
Disturbed injection	<p>The injection should be performed quickly and with a steady pressure. Shaking, unsteady pressure, or injections that take longer than six seconds may cause this message to appear; you should bear this in mind if you are using a large injectate volume (> 10 ml).</p>
Check Injectate Temperature Probe Type	<p>The recorded T_{inj} signal is uncharacteristic for the M1646 injectate temperature probe. An incorrect probe type may have been used.</p>
Unsteady baseline	<p>There is a noisy baseline, and thermal baseline drift.</p>
Multiple peaks	<p>Caused by faulty injection technique.</p>
Abnormal decay time	<p>May be caused by low cardiac output. Calculated value for C.O. may not be accurate.</p>

C.O./CCO Curve Alert Messages	Possible Causes
Very long curve	The decay time of the curve is longer than 15 seconds.
Very short curve	Decay time of the curve is less than 0.5 seconds. If there is a noisy baseline, part of the baseline may have been mistaken for a thermodilution curve. Calculated value for C.O. may not be accurate.
Irregular curve	Any combination of curve alert messages.
Delayed injection	Injection is given more than 15 seconds after Start C.O. is selected. Calculated value for C.O. may not be accurate.

If you have followed all of these guidelines, your measurement values should be valid, even if you still see a curve alert message. Ensure that at least three subsequent measurements within the current series do not differ by more than 15%. If the difference exceeds 15%, use your clinical judgment to determine the appropriate intervention.

C.O./CCO Prompt Messages

Prompt messages appear in the procedure window if a C.O. measurement trial must be terminated.

C.O./CCO Prompt Messages	Possible Causes
Curve below baseline, measurement terminated	May be caused by thermal baseline drift. No C.O. value calculated.
Excessive curve height, measurement terminated	The curve exceeds the upper limit. This may be caused by an injectate that was too cold. No C.O. value calculated.
Unstable baseline, injection not recommended!	The baseline is unstable. Wait until the baseline is stable before injecting. If this does not occur within a reasonable time, injection is possible but the accuracy of the measured values may be reduced.
Excessive baseline drift, don't inject now!	No measurement is possible. Measured values are incorrect.

C.O./CCO Warning Messages

Warning messages contain important information about the C.O. measurement.

C.O./CCO Warning Messages	Possible Causes
Next measurement erases older curve	Six curves are stored, this is the maximum possible. If another measurement is stored, the oldest thermodilution curve will be erased.
Previous C.O. setup data replaced	A C.O. module or measurement extension module has been plugged in with different C.O. setup data from the previous data. The new C.O. setup data is read from the new C.O. device, and replaces the current data. The message disappears when the Start C.O. pop-up key is pressed.

C.O./CCO Warning Messages	Possible Causes
Verify C.O. setup data	A new transpulmonary thermodilution catheter has been connected to the C.O. Interface Cable.
Check arterial pressure, CCO cal currently not possible	Poor or invalid pressure signal, for example if pressure was not zeroed.
Verify the Computation Constant	A new catheter has been plugged in, or the computation constant has been changed and Start C.O. has not been selected.
Previous Comp. Constant replaced	A new C.O. module or measurement extension module with a different computation constant from the current one has been connected. The new computation constant is read from the new C.O. device, and replaces the current one. The message disappears when Start C.O. is selected.

C.O./CCO Safety Information

WARNING

Catheter constant - Make sure that the arterial catheter constant for the measurement is appropriate to the catheter used.

Computation Constant - Make sure that the computation constant for the measurement is appropriate to the injectate volume, injectate temperature and catheter type used.

IABP - Do not perform transpulmonary thermodilution measurements on patients undergoing IABP treatment.

CCO accuracy - Accuracy of the CCO measurement and all the derived values may be influenced by patients with valve diseases or artificial valves.

C.O. and MRI - Do not use the Cardiac Output Interface Cable in Magnetic Resonance Imaging (MRI) Applications.

Aortic graft patients - Do not use an arterial catheter in the arteria femoralis when it is contra indicated, for example, with patients who have an aortic graft.

CAUTION

During the cardiac output measurement procedure the blood temperature alarms are inactive. This is indicated by a crossed-out alarm symbol next to the temperature numeric. Making alarms inactive during this procedure prevents false alarms. The alarms are automatically reactivated when you have completed the measurement procedure.

Monitoring Carbon Dioxide

WARNING

Measurements from an MMS extension connected to an X2 are not available when the X2 is running on its own battery power. They are only available when the X2 is powered by external power: when connected to a host monitor, to the external power supply (M8023A) or to the Battery Extension (865297).

Only one CO₂ measurement at a time is supported.

Use the CO₂ measurement to monitor the patient's respiratory status and to control patient ventilation.

There are two methods for measuring carbon dioxide in the patient's airway:

- Mainstream measurement uses a CO₂ sensor attached to an airway adapter directly inserted into the patient's breathing system. This method is available using the M3014A Capnography Extension and the M3016A Mainstream CO₂ Extension, or the X2 with the optional CO₂ measurement.
- Sidestream measurement takes a sample of the respiratory gas with a constant sample flow from the patient's airway and analyzes it with a remote CO₂ sensor built into the measurement system. Philips offers the sidestream CO₂ measurement in the M3014A Capnography Extension or the X2 with the optional CO₂ measurement, and the Microstream method of sidestream CO₂ measurement in the M3015A/B Microstream CO₂ Extension.

Refer to your Gas Module Instructions for Use, if you are using a Gas Module to monitor CO₂.

WARNING

Correlation: The etCO₂ readings do not always correlate closely with paCO₂, especially in neonatal patients and patients with pulmonary disease, pulmonary embolism or inappropriate ventilation.

Pharmaceuticals in aerosols: Do not measure CO₂ in the presence of pharmaceuticals in aerosols.

Explosion Hazard: Do not use in the presence of flammable anesthetics or gases, such as a flammable anesthetic mixture with air, oxygen or nitrous oxide. Use of the devices in such an environment may present an explosion hazard.

Failure of operation: if the measurement or a sensor fails to respond as described, do not use it until the situation has been corrected by qualified personnel.

Low etCO₂ values: Leakages in the breathing system or sampling system may cause the displayed etCO₂ values to be significantly too low. Always connect all components securely and check for leaks according to standard clinical procedures. Displacement of the nasal or combined nasal oral cannulas can cause lower than actual etCO₂ readings. Even with combined nasal oral cannulas, the etCO₂ readings may be slightly lower than actual in patients breathing through the mouth only.

Measurement Principles

For both mainstream and sidestream measurements, the measurement principle is infrared transmission, where the intensity of infrared light passing the respiratory gas is measured with a photo detector. As some of the infrared light is absorbed by the CO₂ molecules, the amount of light passing the gas probe depends on the concentration of the measured CO₂.

When using a wet ventilator circuit, monitor mainstream CO₂ if available, in preference to sidestream CO₂.

The partial pressure is calculated from the gas concentration by multiplying the concentration value with the ambient pressure.

The measurement provides:

- a CO₂ waveform.
- an end tidal CO₂ (etCO₂) value: the CO₂ value measured at the end of the expiration phase.
- an inspired minimum CO₂ (imCO₂): the smallest value measured during inspiration.
- an airway respiration rate (awRR): the number of breaths per minute, calculated from the CO₂ waveform.

Depending on the **Max Hold** setting configured for your monitor, the etCO₂ numeric shows either the highest CO₂ value measured within the configured time period (**Max Hold** set to **10 sec** or **20 sec**) or the etCO₂ numeric shows breath-to-breath value (**Max Hold** set to **Off**).

The Microstream method also provides an **Integrated Pulmonary Index** (IPI) numeric, which is an indication of the patient's overall ventilatory status based on four measurement parameters: etCO₂, awRR, pulse rate and SpO₂. IPI can thus provide an early indication of a change in ventilatory status which may not be shown by the current value of any of these four parameters individually. The IPI is designed to provide additional information regarding patient status, possibly before etCO₂, awRR, SpO₂, or pulse rate values reach levels of clinical concern.

The IPI is available for all three groups of pediatric patients (1-3 years, 3-6 years, and 6-12 years), and for adult patients. It is displayed as a single value between 1 and 10.

Measuring CO₂ using M3014A or X2

The M3014A Capnography Extension or the X2 with the CO₂ option measures partial pressure of carbon dioxide in a patient's expired gas using the mainstream method or the sidestream method.

The mainstream CO₂ measurement can be used, with appropriate accessories, with intubated adult, pediatric and neonatal patients. The sidestream CO₂ measurement can be used, with appropriate accessories, with intubated and non-intubated adult, pediatric, infant and neonatal patients.

With intubated patients, a sample of the respiratory gas is drawn from the patient's breathing circuit through an airway adapter and a gas sampling tube. With non-intubated patients, the gas sample is drawn through a nasal or oral-nasal cannula.

WARNING

Altitude Setting: The monitor is not equipped with automatic barometric pressure compensation. Before the CO₂ measurement is used for the first time, the altitude must be set to the correct value. An incorrect altitude setting will result in incorrect CO₂ readings. The CO₂ readings will typically deviate 5% for every 1000 m difference.

CAUTION

Use the CO₂ measurement with Philips approved accessories only. Refer to the instructions for use provided with the accessory.

Preparing to Measure Mainstream CO₂

You must perform a zero as described in this procedure each time you use a new airway adapter.

- 1 Attach the sensor connector to the CO₂ connector on the MMS extension, or on the X2 (when the optional CO₂ measurement is integrated).
- 2 Wait 2 minutes, allowing the sensor to reach its operating temperature and a stable thermal condition.

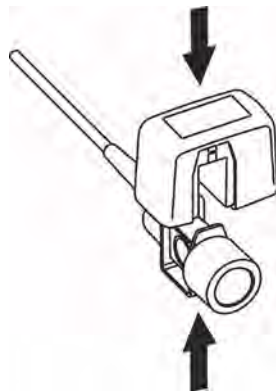

- 3 Choose the appropriate airway adapter and connect it to the sensor head. The airway adapter clicks into place when seated correctly. To zero the sensor:
 - expose the sensor to room air and keep it away from all sources of CO₂ including the ventilator, the patient's breath and your own.
 - in the setup menu for the CO₂, select **Start Zero Cal.**

- When you see the message **CO₂ calibration done at <Date and Time>** on the status line, the zero calibration is finished and you can begin monitoring.

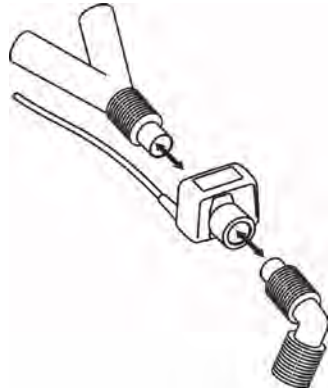

- 4 Install the airway adapter at the proximal end of the circuit between the elbow and the ventilator Y-section.

WARNING

To prevent stress on the endotracheal tube, support the sensor and airway adapter.

Position sensor cables and tubing carefully to avoid entanglement or potential strangulation. Do not apply excessive tension to any cable.

Replace the airway adapter, if excessive moisture or secretions are observed in the tubing or if the CO₂ waveform changes unexpectedly without a change in patient status.

To avoid infection, use only sterilized, disinfected or disposable airway adapters.

Inspect the airway adapters prior to use. Do not use if airway adapter appears to have been damaged or broken. Observe airway adapter color coding for patient population.

Preparing to Measure Sidestream CO₂

- 1 Plug the sensor cable into the monitor's CO₂ input connector. Allow the sensor two minutes warm up time

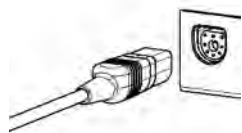

- 2 Connect the cannula, airway adapter, or sample line as appropriate, to the sensor. It will click into place when seated correctly.

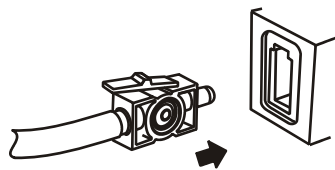

- 3 To zero the sensor:

- expose the sensor to room air and keep it away from all sources of CO₂ including the ventilator, the patient's breath and your own.
 - in the setup menu for the CO₂, select **Start Zero Cal.**
 - when you see the message **CO₂ calibration done at <Date and Time>** on the status line, the zero calibration is finished and you can begin monitoring.
- 4 *For intubated patients requiring an airway adapter:* Install the airway adapter at the proximal end of the circuit between the elbow and the ventilator Y-section.

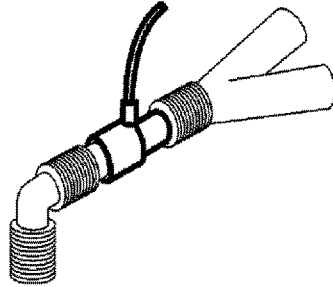

For intubated patients with an integrated airway adapter in the breathing circuit.: Connect the male luer connector on the straight sample line to the female port on the airway adapter.

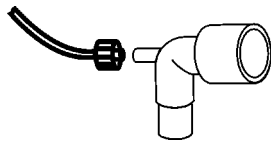

For non-intubated patients: Place the nasal cannula onto the patient.

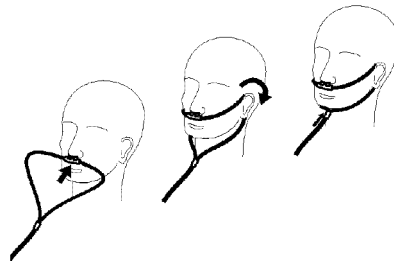

For patients prone to mouth breathing use an oral-nasal cannula.

For nasal or oral-nasal cannulas with oxygen delivery, place the cannula on the patient as shown then attach the oxygen supply tubing to the oxygen delivery system and set the prescribed oxygen flow.

WARNING

Always connect the airway adapter to the sensor before inserting the airway adapter into the breathing circuit. In reverse, always remove the airway adapter from the breathing circuit before removing the sensor.

Make sure that you do not accidentally connect the luer connector of the gas sample line to an infusion line or any other lines in the patient vicinity.

CAUTION

Always disconnect the cannula, airway adapter or sample line from the sensor when not in use.

Using the Sidestream Sensor Holder

The holder delivered with the sensor can be used to clamp the sensor onto an IV pole or a shelf.

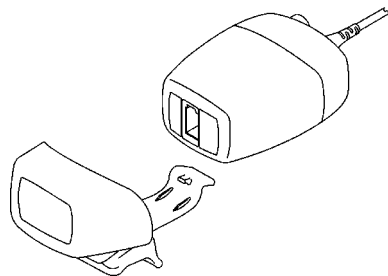

- 1 Push the sensor into the holder until it clicks into position.
- 2 Clamp the holder onto an IV pole, a shelf or another appropriate location.

To remove the sensor from the holder, release the clip and pull the sensor out of the holder.

Removing Exhaust Gases from the System

WARNING

Anesthetics: When using the sidestream CO₂ measurement on patients who are receiving or have recently received anesthetics, connect the outlet to a scavenging system, to avoid exposing medical staff to anesthetics.

Use an exhaust tube to remove the sample gas to a scavenging system. Attach it to the sidestream sensor at the outlet connector.

Measuring Mainstream CO₂ using M3016A

MX600/700/800 The M3016A Mainstream CO₂ Extension measures partial pressure of carbon dioxide in a patient's expired gas using the mainstream method. When using the appropriate accessories you can use the mainstream CO₂ measurement with ventilated adults, pediatric and neonatal patients.

WARNING

Infra-red radiation: Do not expose the airway adapter or M1460A transducer to infra-red radiation during use. This may cause incorrect readings.

Preparing to Measure Mainstream CO₂

- 1 Attach the transducer connector to the CO₂ connector on the M3016A extension.
- 2 Wait 20 minutes, allowing the transducer to reach its operating temperature and a stable thermal condition.
- 3 Perform an accuracy check and then, if necessary, calibrate the transducer.

Checking Transducer Accuracy

WARNING

Check transducer accuracy at least once a week or if you doubt the CO₂ readings.

- 1 In **Setup CO₂** menu, select **Cal. Mode** to switch on calibration mode.
- 2 Look at the calibration value displayed in the **Setup CO₂** menu next to **Start CAL1**. Is it the same as the value on the calstick? If not, calibrate the transducer now.
- 3 Place the transducer on the low cell of the calstick (labeled 0.0 mmHg or "ZERO"). The reading on the screen should be zero within ± 1 mmHg within one minute.
- 4 Place the transducer on the high cell of the calstick. The reading on the screen should be within ± 1 mmHg of the value on the calstick within one minute.
- 5 If both readings are in range, you can leave calibration mode and begin monitoring. If either of the readings is out of range, calibrate the transducer.

Calibrating the Transducer

- 1 Check that the windows on the calstick are clean and clear.
- 2 Place the transducer on one of the calstick cells and select **Start CAL1**.
- 3 Enter the calibration value printed on the calstick then press **Confirm** to start calibration.
- 4 When the message **CO₂ CAL1 calibration done -- Start CAL2 calibration** appears, put the transducer on the other cell and select **Start CAL2** then press **Confirm**.
- 5 When you see the message **CO₂ calibration completed – leave Cal. Mode**, calibration is complete.
- 6 Select **Cal. Mode** to switch calibration mode off. You cannot monitor in calibration mode.

Attaching and Removing the CO₂ Transducer

- 1 Open the latch and place the transducer (B) onto the airway adapter (A). Place the airway adapter in the patient's breathing circuit between the endotracheal tube and the Y-piece. You may see the

CO₂ Sens Warmup message until the transducer reaches operating temperature. Wait until this disappears before starting the measurement.



- 2 To remove the transducer from the airway adapter, open the latch and pull out the airway adapter.



WARNING

To prevent stress on the endotracheal tube, support the transducer and airway adapter.

To avoid infection, use only sterilized airway adapters.

Measuring Microstream CO₂ using M3015A/B

The M3015A/B Microstream CO₂ Extension measures the partial pressure of carbon dioxide in a patient's expired gas using Microstream technology.

The measurement is equipped with an automatic barometric pressure compensation.

WARNING

When using the IPI numeric (available for adult and pediatric patients), always ensure that the patient's date of birth is entered correctly and that the monitor is displaying the current date. These two pieces of information are used to calculate the age of the patient, which affects the algorithm used to provide the IPI numeric.

Preparing to Measure Microstream CO₂

Use appropriate accessories for:

- the patient type (adult, pediatric or neonatal),
- the ventilation situation (including humidification)
- the duration - short term use, up to 24 hours (typically OR), or long term use (typically ICU).

All accessories are for single patient use only.

Using Microstream Accessories

The Microstream measurement can be operated with the special Microstream accessories only. Refer to the instructions for use provided with the accessory.

For intubated patient with non-humidified ventilation, you can use a Microstream FilterLine set. For humidified ventilation, use a FilterLine H Set.

For non-intubated patients, the gas sample is taken through a Nasal FilterLine, or a Smart CapnoLine (which is a combined oral-nasal FilterLine). In parallel to the measurement of the CO₂, oxygen (O₂) may be delivered to the patient to support gas exchange. This is done by using an O₂/CO₂ FilterLine, or a Smart CapnoLine O₂ (a combined oral-nasal O₂/CO₂ FilterLine).

Using the FilterLine and Airway Adapter

WARNING

Make sure that you do not accidentally connect the luer connector of the gas sample line to an infusion link or any other links in the patient vicinity.

- 1 Attach the female Luer connector to the CO₂ inlet connector by pushing the socket cover aside and screwing the connector clockwise into the CO₂ inlet until it can no longer be turned.
This will assure that there is no leak of gases at the connection point during measurement and that measurement accuracy is not compromised. Following connection of the CO₂ sampling line, check that CO₂ values appear on the monitor display.
- 2 Check that the FilterLine is not kinked.
- 3 Change the FilterLine if a **CO₂ Occlusion** INOP appears on the monitor or if the readings become extremely erratic.

Disconnect the FilterLine during suctioning and nebulizing therapies or suppress sampling by turning off the pump as described in “Suppressing Sampling (not Mainstream CO₂)” on page 251.

Check the table in the Microstream CO₂ Accessories section of the Accessories chapter for typical usage times for the different Microstream accessories.

CO₂ values for non-intubated patients using Microstream accessories will always tend to be lower than for intubated patients. If values appear extremely low, check whether the patient is breathing through the mouth or whether one nostril is blocked.

Removing Exhaust Gases from the System

WARNING

Anesthetics: When using the Microstream CO₂ measurement on patients who are receiving or have recently received anesthetics, connect the outlet to a scavenging system, or to the anesthesia machine/ventilator, to avoid exposing medical staff to anesthetics.

Use an exhaust tube to remove the sample gas to a scavenging system. Attach it to the MMS Extension at the outlet connector.

Suppressing Zero Calibration

To prevent an automatic zero calibration from being started in the next five minutes,

- in the **Setup CO₂** menu, select **No Zero for 5min**, or select the **Suppress CO₂ Zero** SmartKey, if configured.

Selecting **No Zero for 5min** or selecting the **Suppress CO₂ Zero** SmartKey again before the timer has timed out resets the timer to five minutes, unless an AutoZero became due during the previous suppression.

Setting up all CO₂ Measurements

These tasks are common to all CO₂ measurements except where otherwise noted.

Adjusting the CO₂ Wave Scale

- 1 In the **CO₂ Wave** menu or the **Setup CO₂** menu, select **Scale**.
- 2 Choose a suitable scale range from the pop-up list.

Setting up CO₂ Corrections

Temperature, water vapor in the patient's breath, barometric pressure, and the proportions of O₂, N₂O and Helium in the mixture all influence CO₂ absorption. If values seem inaccurately high or low, check that the monitor is using the appropriate corrections.

Correction	
Altitude (M3014A only)	Altitude is set during installation. The monitor automatically applies an appropriate correction.
O ₂ (M3014A only)	In the Setup CO₂ menu, select Oxy. Corr and select a value between 20% and 100%, the default value is 20%. If you are not measuring the expired O ₂ , estimate it by subtracting 5% from the inspired O ₂ then select the nearest value from the list.

Correction	
Humidity	At installation, the monitor is configured to automatically apply either Body Temperature Pressure Saturated (BTPS) or Ambient Temperature Pressure Dry (ATPD). To see which, go to the Setup CO₂ menu, and scroll down to look at Hum. Corr or Humidity Corr. .
N ₂ O (M3016A mainstream and M3015A/B microstream only)	In the Setup CO₂ menu, select N₂O Corr. and turn on or off. If N ₂ O is present in the ventilation gas mixture, you must turn this on. If the N ₂ O correction is not available in the Setup CO₂ menu, the CO ₂ measurement in your MMS Extension does not require N ₂ O correction or it is setup with Gas Corr. (see below).
Gas (M3014A only)	In the Setup CO₂ menu, select Gas Corr. and select Helium, N₂O or turn off. If Helium or N ₂ O is present in the ventilation gas mixture, you must make the appropriate selection. If the Gas correction is not available in the Setup CO₂ menu, the CO ₂ measurement in your MMS Extension does not require N ₂ O or Helium correction or the N ₂ O correction is setup with N₂O Corr. (see above).
Agent (M3014A only)	In the Setup CO₂ menu, select Ag. Corr and select the concentration of the anesthetic agent (between 0.0% and 20.0%). If an anesthetic agent is present in the ventilation gas mixture, you must select the appropriate concentration.

Suppressing Sampling (not Mainstream CO₂)

To temporarily stop sampling, in the **Setup CO₂** menu, select **Pump 15min Off** or use the **CO₂ Pump Off** SmartKey if available.

Selecting **Pump 15min Off** again before fifteen minutes have passed resets the timer to fifteen minutes.

To re-start the pump, in the **Setup CO₂** menu, select **Pump On**.

Changing CO₂ Alarms

This refers to CO₂ specific alarms. See the “Alarms” section for general alarm information.

- 1 In the **Setup CO₂** menu, select **etCO₂ High** or **imCO₂ High** and choose the high alarm limit.
- 2 Select **etCO₂ Low** and choose the low alarm limit.

Changing the Apnea Alarm Delay

This determines the time limit after which the monitor alarms if the patient stops breathing.

- 1 In the **Setup CO₂** menu, select **awRR**.
- 2 In **Setup awRR** menu, select **Apnea Time**.
- 3 Choose the apnea alarm delay time.

WARNING

Safety and effectiveness of the respiration measurement method in the detection of apnea, particularly the apnea of prematurity and apnea of infancy, has not been established.

Prolonged delay: The selected apnea alarm delay may be prolonged by up to 17 seconds, if an apnea occurs during the automatic zero process. This applies to the Microstream (M3015A/B) measurement only.

Deriving Alarms From awRR

- 1 In the **Setup CO₂** menu, select **awRR**.
- 2 In the **Setup awRR** menu, select **Alarms**.
- 3 Choose **On** to derive alarms from the airway respiration signal or **Off** to disable them.

Changing awRR Alarm Limits

- 1 In the **Setup CO₂** menu, select **awRR**.
- 2 Select **High Limit** to set the upper alarm limit.
Select **Low Limit** to set the lower alarm limit.
- 3 Select the appropriate setting.

Changing IPI Alarm Limits

- 1 In the **Setup CO₂** menu, select **IPI**.
- 2 Select **Low Limit** to set the low alarm limit.
- 3 Select a value between 2 and 9.

If you also have monitors with earlier software revisions than J.0, the IPI low alarm will not be generated after a transfer to one of these monitors, or when a monitor/MMS with the IPI functionality is connected to one of these monitors in companion mode. In this case, do not rely only on the IPI low alarm but leave the individual alarms switched on (etCO₂, awRR, pulse rate and SpO₂) so that these alarms can be generated in such situations.

Understanding the IPI Numeric

The index is modeled on normal healthy patients (ASA Physical Status value of 1 according to the ASA Physical Status Classification System). Patients with ASA Physical Status values of 3 or higher are expected to have low IPI values by definition. Therefore, for patients with an ASA Physical Status value of 3 or higher, the index may have no added value.

The value of the Integrated Pulmonary Index given in the IPI numeric is associated with the patient status as follows:

IPI	Patient Status
10	Normal
8-9	Within normal range
7	Close to normal range; requires attention

IPI	Patient Status
5-6	Requires attention and may require intervention
3-4	Requires intervention
1-2	Requires immediate intervention.

NOTE

The interpretation of the patient's IPI score may change in different clinical environments. For example, patients with specific respiratory difficulties (in contrast to normally healthy patients who are being monitored during sedation or pain management) may require a lower IPI Low Alarm threshold to reflect their impaired respiratory capacity.

The IPI is available for all three groups of pediatric patients (1-3 years, 3-6 years, and 6-12 years), and for adult patients.

WARNING

Ensure that the patient category and date of birth are set correctly before monitoring a patient's IPI. An incorrect patient category or date of birth could produce incorrect IPI data.

Monitoring Airway Flow, Volume and Pressure

The M1014A Spirometry Module - labeled as SPIRO - is designed to be used in combination with Philips-branded airway flow sensors and combined CO₂/airway flow sensors. It produces a real time wave for flow, volume and pressure of respiratory gases together with numerics for analysis of ventilatory mechanics.

The measurement provides:

- Airway flow, airway volume and airway pressure waveform.
- Numerics for:
 - respiratory rate
 - tidal volume
 - minute volume
 - PEEP (positive end-expiratory pressure)
 - PIP (peak inspiration pressure)
 - dynamic compliance
 - airway resistance
- Numerics for: (only visible in **SpirometryValues** Window, no alarming, no trending)
 - peak inspiratory flow
 - peak expiratory flow
 - negative inspiratory pressure
 - mean airway pressure
 - plateau pressure numeric
 - I:E ratio

The measurement also provides pressure-volume loops, flow-volume loops and pressure-flow loops. See “Respiratory Loops” on page 399 for details on loops.

When using combined CO₂/Flow sensors you can also perform mainstream capnography with intubated adult, pediatric and neonatal patients. See the “Monitoring Carbon Dioxide” chapter for details on the CO₂ measurement and the “Accessories” chapter for a list of compatible accessories.

WARNING

Electrical Shock Hazard: Do not open the module. Contact with exposed electrical components may cause electrical shock. Always turn off and remove power before cleaning the module. Refer servicing to qualified service personnel.

Attaching the Flow Sensor

CAUTION

Use the M1014A Spirometry Module with Philips approved accessories only. Refer to the instructions for use provided with the accessory.

Select the appropriate flow sensor. Make sure that you are using the correct sensor for the respective patient category. Otherwise accuracy may be reduced.

	<p>Pediatric/Adult Flow Sensor (M2785A). Color: clear For intubated patients with endotracheal tube diameters > 4 mm. Adds approximately 6.5 cm³ of dead-space.</p>
	<p>Infant/Neonatal Flow Sensor (M2786A) Color: violet For intubated patients with endotracheal tube diameters ≤ 4 mm. Adds less than 1 cm³ of dead-space.</p>

You can also use combined CO₂/flow sensors. Note that the M3014A Capnography Extension is required to measure CO₂.

	<p>Pediatric/Adult Combined CO₂/Flow Sensor (M2781A). Color: clear For intubated patients with endotracheal tube diameters > 5.5 mm. Adds 8 cm³ of dead-space.</p>
	<p>Pediatric Combined CO₂/Flow Sensor (M2783A): Color: green For intubated patients with endotracheal tube diameters of 3.5 - 6 mm. Adds less than 4 cm³ of dead-space.</p>
	<p>Infant/Neonatal Combined CO₂/Flow Sensor (M2782A). Color: violet For intubated patients with endotracheal tube diameters of 2.5 - 4 mm. Adds less than 1 cm³ of dead-space.</p>

- 1 If you are using a combined CO₂/Flow sensor, connect it to the CO₂ sensor head first. The airway adapter clicks into place when seated correctly.
- 2 Click the connector into place in the flow sensor receptacle on the monitor before connecting to the breathing circuit.

- 3 Install the flow sensor or the combined CO₂/Flow sensor at the proximal end of the breathing circuit between the elbow and the ventilator Y-piece. Make sure that the spirometry sensor is in a horizontal position with its tubing pointing upwards. The correct position is also indicated by an arrow on some of the sensors. (Graphic shows combined CO₂/Flow Sensors).

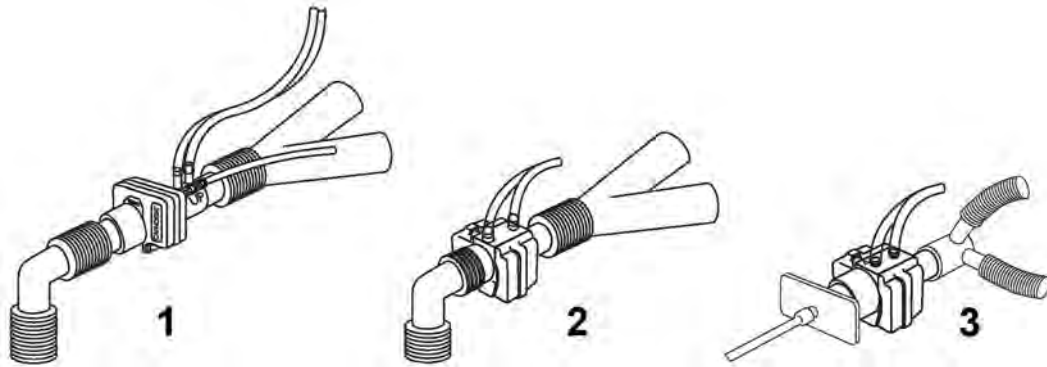

1. Pediatric/adult sensor
2. Pediatric sensor
3. Infant/Neonatal sensor

WARNING

To prevent stress on the endotracheal tube, support the sensor and airway adapter.

Position sensor cables and tubing carefully to avoid entanglement or potential strangulation. Do not apply excessive tension to any cable or tubing.

Replace the sensor, if excessive moisture or secretions are observed in the tubing and cannot be removed by a purge cycle.

Reuse poses a patient hazard. Do not disassemble, clean, disinfect or sterilize the sensor.

A system leak may significantly affect readings of flow, volume, pressure and other respiratory mechanics parameters.

Do not leave the sensor in the patient circuit when not connected to the monitor.

NOTE

- Do NOT place the airway adapter between the endotracheal tube and the elbow (pediatric/adult circuit), as this may allow patient secretions to block adapter windows.
- The striped tubing of the flow sensor should always be proximal to the patient.
- Position the airway adapter with the spirometry tubing pointing upwards.
- To prevent "rain-out" and moisture from draining into the airway adapter, do NOT place the airway adapter in a gravity dependent position.
- Periodically check the flow sensor and tubing for excessive moisture or secretion build up. Perform a purge cycle if droplets are visible within the sensor or tubing. Repeat if necessary. If purging does not remove the droplets, replace the sensor.
- For routine performance of airway care, separate the system between the endotracheal tube and the airway adapter (neonatal circuit), or between the endotracheal tube and elbow (pediatric/adult circuit).

circuit). Lavage and suctioning of the airway can then be performed without fluids and mucous accumulating on the airway adapter windows.

- Measurement values provided by a ventilator may differ significantly from the values provided by the spirometry module, due to different locations of the flow sensor.
- Incorrect entry of gas compensation parameters (i.e. temperature, gas composition) may reduce the accuracy of the measured values.
- An abnormal volume waveform as displayed below may be an indicator of an air leak:

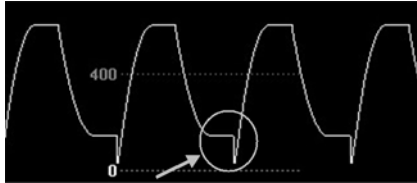

In general, if **MVexp** or **TVexp** are significantly smaller than **MVin** or **TVin**, the tubing should be checked for leaks.

Zero Calibration

The zero calibration maintains the accuracy of the spirometry waves and numerics by regularly compensating for drifts within the measurement section. It is performed automatically without user interaction and takes about 2 seconds to complete. The automatic zero calibration is normally carried out every ten minutes. During warm-up or when the ambient pressure changes, this interval may be reduced to two minutes.

During the zero calibration the waveform is flat but the numerics remain on the screen. Typically, a zero calibration is started at the beginning of a respiration cycle, therefore a waveform may begin normally and then immediately become flat for the time of the zero calibration.

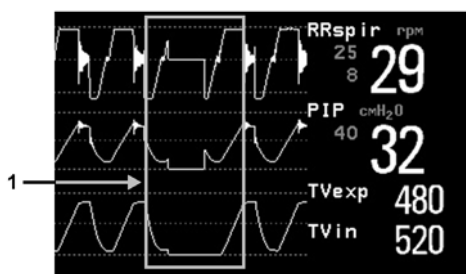

1 Zero Calibration

Automatic Purging

A double lumen connecting line (tubing) connects the flow sensors to the patient monitor. The M1014A Spirometry Module includes an automatic and manual purge feature which provides a flush of room air to keep the sensor tubing free from water condensation and patient secretions. This feature is available for the adult, pediatric, and neonatal modes. The purge will begin with the exhalation portion of the ventilator cycle.

NOTE

- During the purge cycle the pump will be heard

- If the purge does not sufficiently clear the flow tubing lines, the flow sensor should be replaced
- With each purge cycle, a zero calibration is automatically performed

Adult Mode

The system automatically purges the sensor tubing every ten minutes or less, depending on system conditions. In adult mode, the system will purge both sides of the line, one at a time, during each purge cycle. The higher the pressure, the more frequent the purging. This action anticipates increased moisture migration into the sensor tubing due to the increase in circuit pressure.

Neonatal and Pediatric Modes

The automatic purge cycles used in the neonatal or pediatric mode is fixed at every three minutes regardless of circuit pressure. Only one side of the sensor tubing will be purged during each purge cycle.

Unlike the adult purge mode, the neonatal or pediatric purge mode does not use the full force of the internal pump, but rather pressurizes an internal reservoir which is used for the purge. This minimizes the pressure delivered to the ventilator circuit, but does deliver a sufficient pressure to purge the sensor tubing.

Manual Purging

Occasionally, purging may be required in between the automatic purge cycles. The manual purge may be used as often as needed. Check the orientation of the flow sensor if repeated manual purge cycles become necessary.

To manually purge, press the Purge button on the module (marked by  on international versions of the module) or select **Purge** in the **Setup Spirometry** window to initiate a combined purge and zero cycle.

Gas Compensation

Temperature and the proportions of individual gases influence the flow measurement. If values seem inaccurately high or low, check that the monitor is using the appropriate gas compensation. Gas compensation can be done using either manually entered gas concentrations or gas concentrations from the gas analyzer.

NOTE

If you unintentionally switch the gas compensation to the incorrect setting, the accuracy of the measured flow and volume values may be significantly reduced. The tables below show examples of incorrect gas compensation settings and the resulting inaccuracies:

	N ₂	O ₂	N ₂ O	Agent	Difference between measured and actual values
Actual Gas Composition	60	40			
Gas Compensation Setting		40	60		15%

Incorrect Balance Gas Setting (N₂O instead of N₂)

	N ₂	O ₂	N ₂ O	Agent	Difference between measured and actual values
Actual Gas Composition	55	40		5	
Gas Compensation Setting	60	40		0	15%

Incorrect Agent Percentage Setting

Setting up Spirometry

The following settings can be accessed through the **Setup Spirometry** menu.

Optimizing Scale Settings

In the **Setup Spirometry** menu, select **Optimize Scales**. The scale settings for all three spirometry waves (AWF, AWP, AWV) will be optimized.

Spirometry Values Window

You can view all spirometry measurement data in the spirometry data window. In the **Setup Spirometry** menu, select **Show All Values**.

Alarms and Alarm Limits

Alarms can be derived from PEEP, PIP, MV and RR_{spir}. In the **Setup Spirometry** menu you can set the alarm limits. Refer to the Alarms chapter of this manual for details on alarm settings.

Changing the Apnea Alarm Delay

This determines the time limit after which the monitor alarms if the patient stops breathing.

- 1 In the **Setup Spirometry** menu, select **RR_{spir}**.
- 2 In **Setup RR_{spir}** menu, select **Apnea Time**.
- 3 Choose the apnea alarm delay time.

WARNING

- **Safety and effectiveness** of the respiration measurement method in the detection of apnea, particularly the apnea of prematurity and apnea of infancy, has not been established.
 - If an apnea occurs during a zero calibration or purge, the time delay between the start of apnea and the activation of the apnea alarm could be up to 10 seconds plus the configured apnea delay time.
-

Automatic Alarm Suppression

If the automatic alarm suppression is switched on, all spirometry alarms are suppressed until breathing activity has been detected. This setting must be made in configuration mode.

Choosing Measured AWW Components

- 1 In the **Setup Spirometry** menu, select **AWW**.
- 2 Select **MV** to choose the measured components for Minute Volume (inspiratory and/or expiratory or off).
Select **TV** to choose the measured components for Tidal Volume (inspiratory and/or expiratory or off).

NOTE

If MV and TV are set to off, there will be no alarming for these parameters.

Setting the Gas Compensation Mode

- 1 In the **Setup Spirometry** menu, select **Gas Compensation**.
- 2 Select **Mode** to choose the Gas Compensation mode:
 - select **Manual** for manually entered gas concentrations or
 - select **Gas Analyzer** for gas concentrations from the gas analyzer.

NOTE

- Gas concentrations from the gas analyzer are only available for Philips gas analyzers, not for devices connected via a Vuelink/IntelliBridge module.
- If gas concentrations from the gas analyzer are selected but not all data is available, the missing data is taken from manually entered values. In case of invalid data or no data at all, the INOP message **Spiro Gas Compens?** is displayed.

Changing the Type of Balance Gas

- 1 In the **Setup Spirometry** menu, select **Gas Compensation**.
- 2 Select **Balance Gas** to change the type of balance gas.
- 3 Select the appropriate setting (N₂ or N₂O).

Changing the Concentration of Inspired O₂ and the Inspired Agents

- 1 In the **Setup Spirometry** menu, select **Gas Compensation**.
- 2 Select **Inspired O₂** to change the concentration of inspired O₂.
Select **Inspired Agent** to change the concentration of the inspired agent(s).
- 3 Select the appropriate setting.

Changing the Temperature of the Inspired Gas

Depending on the type of ventilator environment (e.g. if you are using a Heat Moisture Exchanger) you may want to change the temperature setting of the inspired gas:

- 1 In the **Setup Spirometry** menu, select **Gas Compensation**.
- 2 Select **Inspired Temp** to change the temperature of the inspired gas.
- 3 Select the appropriate temperature setting.

NOTE

Changing the temperature setting unintentionally will result in approximately 3% reduced accuracy per 10°C (18°F) temperature setting change.

Monitoring tcGas

The tcGas module measures the partial pressure of the oxygen and carbon dioxide that diffuses through the skin, thereby providing a measure of these gases in the capillary blood.

The monitor's settings for altitude and barometric pressure influence the measurement. The tcpO₂/tcpCO₂ measurement is valid for an infant patient not under gas anesthesia. Anesthetic agents, such as halothane, can cause incorrect or drifting readings.

Transcutaneous measurements cannot replace arterial blood gas monitoring. However, you can use transcutaneous monitoring to reduce the frequency of arterial sampling. The values at tissue level will not be the same as those measured arterially because the measurement is transcutaneous. They correlate with (track closely) the arterial values. For example, a drop in transcutaneous values usually indicates a corresponding drop in arterial values.

Transcutaneous values will not always correlate with blood samples taken from the capillary blood of the heel (heelsticks or astrups).

Identifying tcGas Module Components

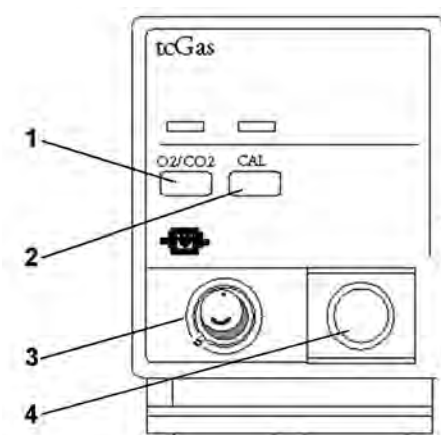

- 1 Press to enter **Setup tcGas** menu
- 2 Press to start calibration
- 3 Calibration chamber
- 4 Transducer connector

Setting the tcGas Sensor Temperature

- 1 In the **Setup tcGas** menu, select **Transducer Temp.**
- 2 Choose a temperature value appropriate for your patient's age, weight and physical condition in accordance with your hospital policy.
Usually, a higher transducer temperature gives a better correlation and a quicker response time. However, higher temperatures also increase the risk of skin burns. Most physicians prefer a temperature between 42°C (107°F) and 44°C (111°F), and a site time of four hours or less. Usually, the higher the transducer temperature, the less the site time should be. Whenever you change the temperature setting, the monitor forces you to make a new calibration.

Using the tcGas Site Timer

Availability and behavior of the site timer depend on your monitor's configuration.

WARNING

Prolonged continuous monitoring may increase the risk of undesirable changes in skin characteristics, such as irritation, reddening, blistering or burns. If the site timer is disabled, the transducer will heat indefinitely while on a patient. Change the site regularly, in accordance with medical procedures in your hospital.

Setting the tcGas Site Timer

The site timer helps reduce the risk of skin burn by ensuring that the transducer is used at one site for no longer than a predefined period. It reminds you when this period expires.

- 1 In the **Setup tcGas** menu, select **Site Time**.
- 2 Choose the time you want the transducer to remain on the measurement site. The optimum time depends on the transducer temperature and your patient's skin sensitivity.

The site timer starts automatically when you remove the calibrated transducer from the calibration chamber. If you return the transducer to the chamber and then remove it again, the site time continues to count down the remaining time; it does not start a new time period. The time remaining before the site timer expires appears in the status line which is visible as long as the **Setup tcGas** menu is open. When the time expires, the monitor sounds a tone and a displays a change site INOP. The monitor either switches off the transducer heating or continues monitoring, depending on its configuration. Although you can reuse the transducer for up to two hours after the heating is switched off, without making a new calibration, you are recommended to recalibrate before applying it to a patient. After two hours without heat, you must recalibrate.

During the initial few minutes of use, the monitor eliminates false alarms by temporarily suppressing tcGas alarms. It displays the **<tcGas Label> Stabilizing INOP**. After you apply the transducer to the skin, the instrument reading slowly assumes a steady value. The reading stabilizes when the measurement site is warm and local hyperemization is complete. This takes 10 to 20 minutes for the tcpO₂ reading and three to seven minutes for tcpCO₂.

Restarting the tcGas SiteTimer

To restart the site timer without recalibration (for example, after the site time has elapsed):

- 1 In the **Setup tcGas** menu, select **Site Time**.
- 2 Enter and confirm your desired time.

Disabling the tcGas Site Timer

Depending on your monitor's configuration, you might be able to disable the site timer. Remember, this means that the transducer heats indefinitely while on a patient.

- 1 In **Setup tcGas** menu, select **Site Timer** and switch this to **Disabled**.
- 2 Select the **Confirm** pop-up key.

Setting the tcGas Barometric Pressure

Altitude and barometric pressure affect tcGas values. The monitor derives barometric pressure from its altitude setting. If you want to set the true barometric pressure you must do this **before** starting a calibration - changes after calibration do not influence tcGas values. The monitor remembers this pressure setting until you enter a new one.

- 1 In the **Setup tcGas** menu, select **Ambient Pressure**.
- 2 Enter the current barometric pressure reading indicated by your barometer.
- 3 Select the **Confirm** pop-up key.

Remembraning the tcGas Transducer

Follow the instructions supplied with the transducer.

New/Dried Out Transducers

Remembrane all new or dried out transducers twice before using. After the first remembraning, unplug the transducer from the module and leave it for 24 hours with the cap on. Remembrane again before calibrating.

Storing tcGas Transducers

If you need to store a sensor for more than 24 hours, protect it for up to 28 days by putting two drops of electrolyte solution into the cap. Screw the cap on the sensor. Remembrane if it dries out or after 28 days.

Calibrating the tcGas Transducer

You can use either a Philips (15210B) or a Radiometer TCC3 calibration unit and a gas cylinder whose pressure indicator is above the 'out-of-gas' zone (black on 15210B, red on TCC3). To maintain accuracy, it is recommended to calibrate the transducer every four hours, even if the monitor does not prompt you to do so. You **MUST** calibrate when:

- you remembrane the transducer
- you change the transducer heat setting

- you doubt the measurement accuracy
 - you start a new monitoring period or use a new site
 - the monitor displays the **Calibration required** INOP message.
- 1 Connect the calibration unit to the inlet on the side of the module's calibration chamber using the recommended gas tubing. Different tubing will cause inaccurate measurements.

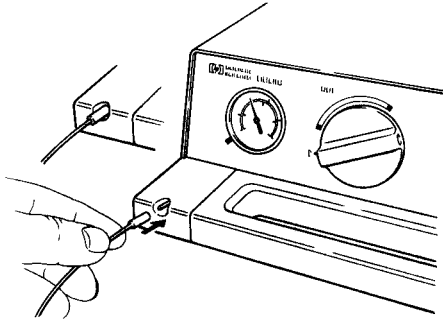

- 2 Plug the transducer cable into the module. Swing the calibration chamber cover open and insert the transducer into the chamber. Close the cover to secure the transducer. Set the transducer temperature at the monitor now.

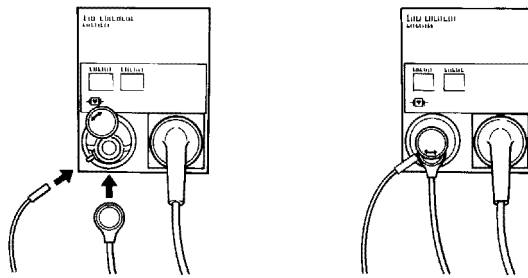

- 3 On the 15210B calibration unit, turn the timer control clockwise as far as you can. On the Radiometer calibration unit, press the button with the green arrow once.

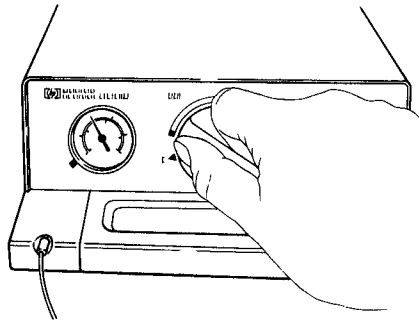

- 4 Press CAL on the module until the light above the key comes on and wait (three - 20 minutes) for the completion message to appear on the monitor. Alternatively, in the **Setup tcGas** menu, select **StartCalibration**. To save gas on 15210B, if the timer control dial is not in the start position when the monitor displays the completion message, turn the dial counter-clockwise to the start position. For TCC3, if the green light is still flashing when INOP <tcGas Label> **Cal Running** disappears, press the green arrow button again.

Calibration Failure

If calibration fails, the monitor displays **<tcGas Label> transducer or cal. unit malfunction** and the **<tcGas Label> Cal Failed INOP** for the measurement.

Troubleshooting tcGas Calibration

Perform each of the following steps, in order, until calibration is successful.

- 1 Check the calibration unit, then recalibrate, remembering to turn on the gas supply on the calibration unit. If the pressure indicator reading is in the out of gas zone, there is insufficient gas in the cylinder. Connect the gas tubing firmly to the calibration unit and to the module's calibration chamber.
- 2 If Step 1 fails, check whether you need to activate the transducer (necessary if the electrolyte has dried out or if you have a new transducer). Remembrane the transducer, removing the old membranes, and cleaning the transducer head thoroughly.
- 3 Calibrate a second time.
- 4 If Step 2 is unsuccessful, calibrate again. This calibration may be required to stabilize the electrochemical system in the transducer.
- 5 Only if the above steps are unsuccessful (you have activated and remembraned the transducer and calibration has still failed twice), replace the transducer.

Applying the tcGas Transducer

- 1 Peel protection film from fixation ring. Using a finger, press the sticky side of the ring on to clean, dry skin. Press around the outside to ensure a good seal. Apply three to five drops of contact fluid in the ring's center. Remove transducer from chamber.

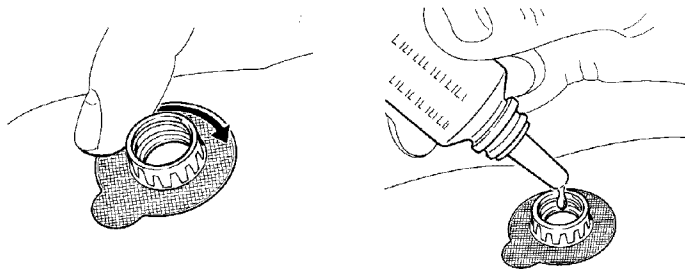

- 2 Align the arrow on the transducer with the tab on the ring and fasten by turning a quarter-turn clockwise. Wait 10-20 minutes for readings to stabilize.

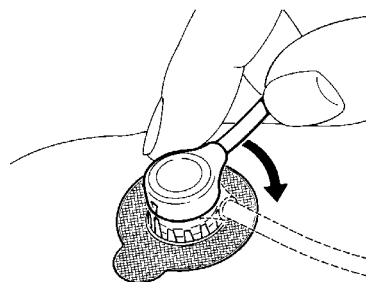

- 3 Apply the transducer as soon as possible after you see the message indicating that calibration is complete. If you wait longer than 30 minutes, the heat supply to the transducer switches off to prevent the electrolyte from drying out and a new calibration is necessary.

Optimize the measurement by selecting a site with high capillary density and blood flow, thin epidermis and no cardiovascular disorders. Most physicians use the abdomen, chest and back.

WARNING

You must either remove the transducer before defibrillating, or remembrane and calibrate the transducer after defibrillating.

CAUTION

To avoid transducer damage, remove it from the patient during high frequency surgical procedures.

Selecting the tcGas HeatPowerDisplay Mode

The heat power display gives an indication of the skin's perfusion below the transducer and of the transducer's contact with the skin. If the transducer loses contact, the heat power value drops significantly. When perfusion is poor you need less heat power to maintain the transducer temperature.

- In the **Setup tcGas** menu, select **HeatPowerDisplay** and then **Relative** or **Absolute**. Choose **Relative** when the skin temperature is stable (the **<tcGas Label> Stabilizing INOP** disappears). This indicates subsequent changes in the relative heat power (and therefore changes in perfusion or transducer contact) since the last zeroing.

Finishing tcGas Monitoring

Replace the transducer in the calibration chamber.

When changing the application site after a measuring period, some users leave the fixation rings in position to allow them to quickly move the transducer from site to site. Always unscrew the transducer from the fixation ring before removing the fixation ring from the skin.

Zeroing the tcGas Relative Heat Power

When you start a calibration, the **HeatPowerDisplay** is set to **Absolute**. When you switch to **Relative**, it automatically zeros. Zero again if you change application site.

TcGas Corrections

Transcutaneous pCO₂ values tend to be higher than arterial values due to the metabolic processes of the skin and the effect of heating on the blood under the transducer. Depending on your monitor's configuration, one or both of these corrections may automatically apply.

Temperature Correction for tcpCO₂

The transducer temperature causes an increase in partial CO₂ pressure. Your monitor may be configured to correct this.

- In the **Setup tcGas** menu, look at the menu item **CO₂ Correction**. If correction is enabled, it is set to **On**.

Metabolism Correction for tcpCO₂

CO₂ production in the epidermis increases the CO₂ value. Your monitor may be configured to automatically deduct a metabolism factor (only applies when **CO₂ Correction** is on).

In the **Setup tcGas** menu, look at the value shown for the menu item **MetabolismFactor**. This is deducted from the CO₂ value.

Monitoring Intravascular Oxygen Saturation

Depending on the probe or catheter used and the measurement location, the two modules, M1011A and M1021A, measure the central venous oxygen saturation or mixed venous oxygen saturation continuously and invasively.

The two modules can be differentiated by their size and their labeling. The M1011A is a single-width module (narrow) and is labeled SO_2 . The M1021A is a double-width module (wide) and is labeled SvO_2 .



- 1 M1011A
- 2 M1021A

WARNING

Injected dyes, such as methylene blue, or intravascular dyshemoglobin may lead to inaccurate measurements.

Do not monitor oxygen saturation during infusion of I.V. fat emulsion or other turbid substances through the distal lumen of the OptiCath catheter. These liquids might temporarily modify the blood scattering and absorption characteristics at the catheter tip. This interferes with the optical measurement of oxygen saturation. After infusion is complete, you can again monitor oxygen saturation accurately.

During injection of the bolus for thermodilution cardiac output measurements, the SvO_2 measurement might be disturbed.

Explosion Hazard: Do not use in the presence of flammable anesthetics or gases, such as a flammable anesthetic mixture with air, oxygen or nitrous oxide. Use of the devices in such an environment may present an explosion hazard.

Do not use probes/catheters when they, or the packaging, are damaged.

Always select the correct label for the measurement location and the catheter/probe in use. This is especially important when Protocol Watch is in use, to ensure that the correct limits are used for the criteria applied.

CAUTION

Use the modules with Philips approved accessories only. Refer to the instructions for use provided with the accessory.

Selecting a Measurement Label

Always select a measurement label before inserting a catheter/probe.

Use the SvO₂ label when the catheter/probe will be located in the pulmonary artery (measuring mixed venous oxygen saturation). This is the only label which allows the measurement value to be used to calculate oxygen extraction (see “Calculating Oxygen Extraction” on page 277) and in the standard oxygen calculations.

Use the ScvO₂ label when the catheter/probe will be located in a central vein (measuring central venous oxygen saturation).

Use the SO₂ label in all other cases.

To select a measurement label:

- 1 Select **Main Setup** then **Measurements** followed by **<SO₂ Label>**
- 2 Select **Label**.
- 3 Select the appropriate label for the catheter/probe location.

Preparing to Monitor with the M1021A Wide Module

In addition to the measurement module, you need a Hospira OptiCath catheter, and 50131 Optical Module. Use only the Hospira accessories listed in the Accessories section.

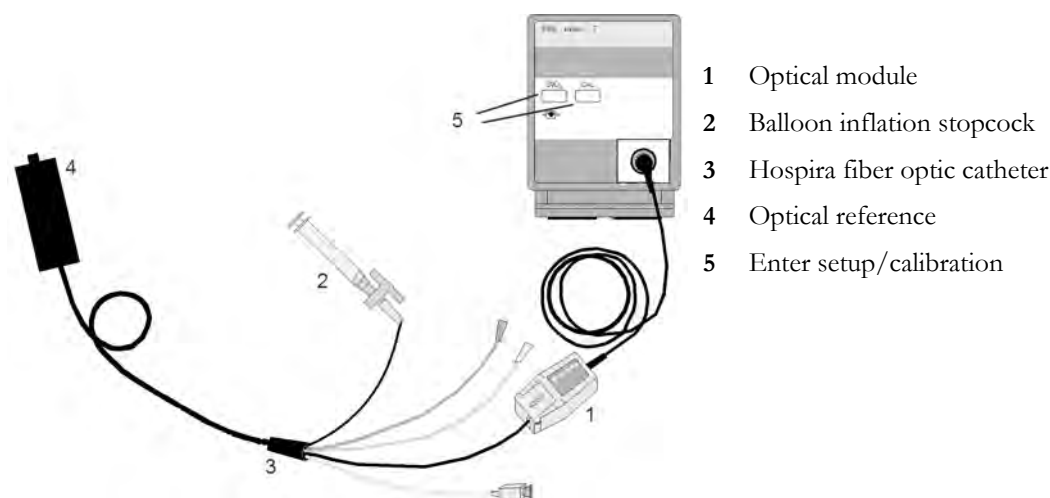

Connect the optical module (Hospira 50131) to the measurement module. Allow the optical module to warm up before you perform a calibration. Although the warm up message disappears from the screen after one minute, Hospira recommends letting the optical module warm up for 15 minutes for best accuracy. Please refer to the instructions for the optical module.

To avoid false alarms during the pre-insertion calibration and insertion of the catheter into the patient, the monitor automatically suspends alarms during the pre-insertion calibration, for up to three minutes after you remove the catheter tip from the optical reference. After light intensity calibration, or after three minutes (whichever comes first), the monitor returns to the alarm state it was in prior to pre-insertion calibration.

Carrying out a Pre-insertion Calibration

WARNING

It is strongly recommended to carry out a pre-insertion calibration prior to all insertions. If this is not possible, you must perform an in-vivo calibration after insertion.

Refer to the instructions for use that accompany the catheter. Do not use the catheter if the packaging is damaged. If you have to disconnect the monitor from the patient (for example, when transferring the patient from one location to another), you must disconnect at the SvO₂ module. The catheter should remain in the optical module, otherwise you need to recalibrate.

- 1 Remove outer wrapping from catheter tray to uncover optical connector.
- 2 Place the optical module on the catheter tray in the space provided and open the lid.
- 3 Place the optical connector into the optical module (with the label "TOP" facing upwards) and close the lid.
- 4 In the **Setup <SO₂ Label>** menu, select **Start Pre-InsCal**. Ensure that the tip of the catheter is still in the optical reference.
- 5 Insert the catheter when you see the message **<SO₂ Label> calibration completed – catheter ready for insertion**. If the calibration fails, repeat the calibration before inserting the catheter. If it fails a second time, replace the optical module.

Inserting the Catheter

- 1 Remove the inner cover of the catheter tray.
- 2 Remove the catheter tip from the optical reference. Check the catheter's proper operation (for example: the balloon tip).
- 3 Prepare and insert the catheter in accordance with standard hospital practice.

The SvO₂ catheter is thin and flexible, treat it carefully. Avoid kinking, bending or grasping the catheter with forceps or a hemostat. Damage to the fiber results in low intensity light and sudden decrease in intensity readings. Refer to the documentation provided with the fiber-optic catheter, paying special attention to any precautions, warnings or contraindications.

Secure the optical module directly or in close proximity to the patient, to avoid placing excessive tension on the catheter, which would result in movement of the catheter tip from the optimal position in the patient. Position the optical module to avoid contact with liquids, because fluid entering the catheter-optical module connection may impair light transmission.

If you place the catheter in the patient without performing the pre-insertion calibration, you **must** perform an in-vivo calibration once the catheter is in place.

Performing a Light Intensity Calibration

Perform a light intensity calibration after the catheter is in its proper position. When the catheter is positioned properly, the light intensity indicator must cover at least two small divisions above the midpoint.



- In the **Setup <SO₂ Label>** menu, select **Start Light Cal.**

Calibration is complete after a few seconds. If you doubt existing light intensity readings, recalibrate.

Performing In-Vivo Calibration

Perform an in-vivo calibration:

- if you place the catheter in a patient without performing a pre-insertion calibration.
- if the catheter was disconnected from the optical module.
- when the catheter has been in the patient for 24 hours.
- if any significant change in light intensity occurs that the monitor cannot correct automatically.

Setting Up the In-Vivo Calibration

Check for:

- proper positioning of the probe/catheter in the patient.
- relatively stable oxygen saturation in patient.
- that the light intensity indicator is indicating a stable medium to high level.

Making the In-Vivo Calibration

- 1 Be prepared to draw a blood sample from the patient.
- 2 In the **Setup <SO₂ Label>** menu, select **Start In-VivoCal**.
- 3 To clear the distal lumen, draw off and discard at least 2 ml of blood before taking the sample.
- 4 Draw a blood sample from the distal port of the catheter and flush the line according to standard hospital practice.
- 5 Obtain laboratory analysis of the sample using direct measurements.
- 6 Select **CalibrationValue** and select from the list the value received from the lab.
- 7 Complete the calibration by selecting **Store In-VivoCal** (even if the stored calibration value did not change) and select **Confirm**. This updates the data stored in the optical module.
Selecting **Recall Last Cal** recalls the previously stored calibration value.

If the calibration fails, check that the light intensity indicator is indicating a stable medium to high level. Repeat the calibration.

Preparing to Monitor with the M1011A Narrow Module

In addition to the module, you need a Philips SO₂ Optical Module and a compatible fiber optic probe or catheter. Use only the accessories listed as applicable for the intended measurement location in the Accessories section.



Connecting the Optical Module

- 1 Connect the optical module to the SO₂ module. Allow the optical module to warm up before you insert the probe/catheter and perform a calibration.
Although the warmup message disappears from the screen after one minute, it is preferable to let the optical module warm up for 10 minutes for best accuracy.
- 2 Place the optical module on the catheter tray in the space provided and open the lid.
- 3 Insert the SO₂ probe/catheter connector into the socket in the optical module until it snaps into place.
- 4 Close the lid.
- 5 For instructions on the placement of fiber optic catheters/probes, refer to the documentation provided with the accessory.

After Insertion

The SO₂ probe/catheter is thin and flexible, treat it carefully. Avoid kinking, bending or grasping the probe/catheter with forceps or a hemostat. Damage to the fiber results in low intensity light and a sudden decrease in intensity readings. Refer to the documentation provided with the fibre-optic probe/catheter, paying special attention to any precautions, warnings or contraindications.

Secure the optical module directly attached or in close proximity to the patient, to avoid placing excessive tension on the catheter, which would result in movement of the catheter tip from the optimal position in the patient.

Position the optical module to avoid contact with liquids. Fluid entering the catheter-optical module connection will impair measurement performance.

You **must** perform an in-vivo calibration once the probe/catheter is in place.

The probe/catheter should be replaced after it has been in place for 72 hours.

CAUTION

Do not apply excessive tension to any cable or part of the catheter.

Performing In-Vivo Calibration

Perform an in-vivo calibration:

- when you place the catheter in a patient.
- if the catheter was disconnected from the optical module.
- when the catheter has been in the patient for 24 hours.
- if any significant change in light intensity occurs that the monitor cannot correct automatically.

Setting Up the In-Vivo Calibration

Check for:

- proper positioning of the probe/catheter in the patient.
- relatively stable oxygen saturation in patient.
- that the light intensity indicator is indicating a stable medium to high level.

Depending on the probe/catheter in use you may need to enter a catheter correction factor. This can be found printed on the connector of the probe/catheter. The correction factor must only be entered if it is different from the one currently stored. To see the current correction factor:

- 1 In the **Setup <SO₂ Label>** menu, select **Catheter Factor**.
- 2 If the correction factor displayed is different from the one on the connector, note the correction factor from the probe/catheter for entry during calibration.

Making the In-Vivo Calibration

- 1 Be prepared to draw a blood sample from the patient.
- 2 In the **Setup <SO₂ Label>** menu, select **Start In-VivoCal**.
- 3 To clear the distal lumen, draw off and discard at least 2 ml of blood before taking the sample.

- 4 Draw a blood sample from the distal port of the catheter and flush the line according to standard hospital practice.
- 5 Obtain laboratory analysis of the sample using direct measurements.
- 6 Select **CalibrationValue** and select from the list the value received from the lab.
- 7 Select **Hct [%]** (or **Hb [mmol/l]** or **Hb [g/dl]** depending on the set up) and enter the corresponding value from the laboratory analysis.
To change the setup for entering the Hb/Hct, see “Changing the Lab Value Required for Entry” on page 277 below.
- 8 If you need to enter a new correction factor, select **Catheter Factor**.
- 9 Enter the correction factor.
- 10 Complete the calibration by selecting **Store In-VivoCal** (even if the stored calibration value did not change) and select **Confirm**. This updates the data stored in the optical module.
Selecting **Recall Last Cal** recalls the previously stored calibration value.

If the calibration fails, check that the light intensity indicator is indicating a stable medium to high level. Repeat the calibration.

Changing the Lab Value Required for Entry

You can change the lab value required to be entered: **Hb [g/dl]**, **Hb [mmol/l]** or **Hct [%]**.

- 1 In the **Setup <SO₂ Label>** menu, select **Hb/Hct Entry**.
- 2 Select your preferred lab value and unit.

Further Information for Both Modules

Checking Suspicious Values

If you have any doubts about the correctness of the measurement value, take a blood sample and have it analyzed using standard laboratory procedures.

Calculating Oxygen Extraction

Oxygen extraction is the difference between the measured SpO₂ and SvO₂ values. If you are monitoring SpO₂ and SvO₂, the monitor can calculate this value and display it as a numeric.

- To switch oxygen extraction calculation on or off, in the **Setup Sp-vO₂** menu, select **Sp-vO₂** and toggle between **On** and **Off**.
- If more than one SpO₂ value is available, you must choose which value is used in the calculation.
In the **Setup Sp-vO₂** menu, select **SpO₂ Source** and select the required source.

If one of the calculation sources becomes unavailable, the monitor displays the **INOP Sp-vO₂ Chk Sources** for one minute. After this time, the calculation automatically switches off. If the missing source becomes available again, the calculation automatically switches on again.

Monitoring EEG

The Electroencephalograph (EEG) module monitors the patient's cerebral function by measuring the electrical activity of the brain. It provides the monitor with two channels of realtime EEG waves, EEG trend information in the form of Compressed Spectral Arrays (CSA), and up to eight of the following numerics:

Spectral Edge Frequency - The SEF is the frequency below which a defined percentage of the Total Power lies. The percentage is set in Configuration Mode.

Mean Dominant Frequency (MDF) - The MDF is the mean value of the frequency which dominates the measured EEG.

Peak Power Frequency (PPF) - The PPF is the frequency with the highest measured amplitude.

Total Power (TP) - The TP numeric indicates the power in the measured frequency band.

Percentage of total power in each frequency band:

- **Alpha** waves (8 to 13 Hz)
- **Beta** waves (13 to 30 Hz)
- **Theta** waves (4 to 8 Hz)
- **Delta** waves (0.5 to 4 Hz).

EEG Monitoring Setup

- 1 Plug the trunk cable into the EEG module.
- 2 Prepare the patient's skin prior to placing the electrodes. Good electrode-to-skin contact is important for a good EEG signal, as the skin is a poor conductor of electricity.
 - Shave hair from sites, if necessary.
 - Wash sites thoroughly with soap and water. We do not recommend using ether or pure alcohol, because this dries the skin and increases the resistance.
 - Use a skin preparation paste to remove skin cells and oil before placing the electrodes.
- 3 Select the desired electrode montage in the **Setup EEG** menu or in the **EEG Impedance / Montage** window.
- 4 Attach the reference electrode first.
- 5 Place the electrodes on the patient's head according to the selected montage. Use electrode gel if you are not using pre-gelled electrodes. Remember to select a site where the signal will not be interfered with by muscle artifacts.
- 6 Connect the electrode connector end to the trunk cable.

- 7 Check the electrode-to-skin impedance in the **EEG Impedance / Montage** window.
- 8 For good signal quality, keep all lead wires together and away from other electric devices and metallic bodies.

Using the EEG Impedance/Montage Window

To open the window, in the **Setup EEG** menu, select **Show Montage**, or select the **EEG Montage** SmartKey.

The window may be configured to look slightly different on your monitor.

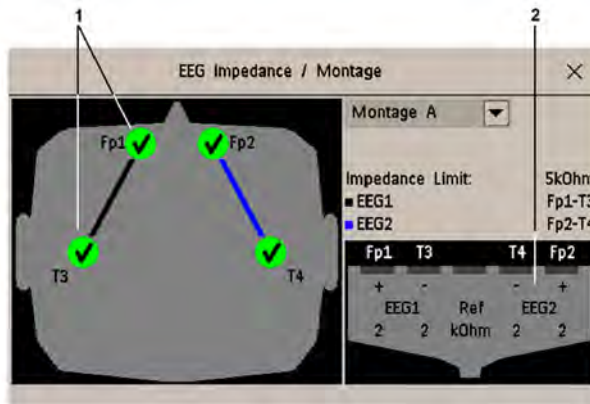

- 1 Electrode locations on the patient's head. The symbols represent the electrode-to-skin impedance.
- 2 Wiring and impedance values for the selected montage.

Choosing an EEG Electrode Montage

- 1 To activate one of the five pre-configured electrode montages, select the arrow beside the label in the **EEG Impedance / Montage** window and choose a montage from the list.
- 2 Attach the electrodes as illustrated in the **EEG Impedance / Montage** window.

The five default electrode montage configurations can be modified and renamed in Configuration Mode.

Montage Name	EEG1+	EEG1-	Label1	EEG2+	EEG2-	Label2
Montage A	Fp1	T3	Fp1-T3	Fp2	T4	Fp2-T4
Montage B	O1	T3	O1-T3	O2	T4	O2-T4
Montage C	F3	C3	F3-C3	F4	C4	F4-C4
Montage D	C3	P3	C3-P3	C4	P4	C4-P4
Montage E	Fp1	T5	Fp1-T5	Fp2	T6	Fp2-T6

The electrode locations are labeled according to the international 10-20 electrode placement system.

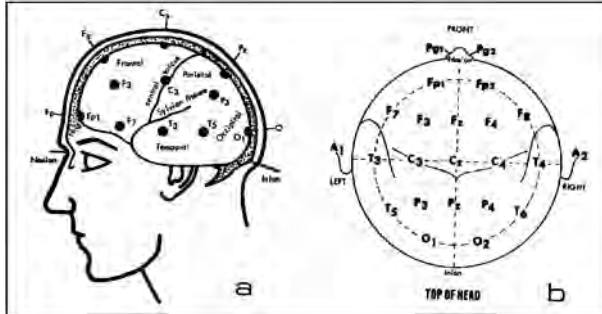

Changing the Impedance Limit

The impedance limit can be set for all electrodes simultaneously in the **Setup EEG** menu, or in the **EEG Impedance / Montage** window using the pop-up keys. If the limit is exceeded during monitoring, an INOP will appear and the graphic impedance indicator will change.

To change the impedance limit, either





- use the pop-up keys that appear with the **EEG Impedance / Montage** window, or
- in the **Setup EEG** menu, select **Impedance Limit** to call up a list of selections between 0 and 30 kOhm, then select the required limit from this list.

About Electrode-to-Skin Impedance

Electrode-to-skin impedance is the main quality indicator for the measured EEG signal. During normal EEG monitoring, electrode-to-skin impedance is measured continuously and disconnected electrodes are detected. The impedance value for each single, independent signal electrode is displayed in the **EEG Impedance / Montage** window. If the measured electrode-to-skin impedance of one or more electrodes is above the limit, an INOP will be issued.

For impedance measurement at least two electrodes, plus the reference electrode, must be connected.

Impedance Indicators

Electrode/Skin Impedance	Symbol	Color	Displayed Impedance Value	Action
Electrode not connected		red	no value	connect electrode
Noisy signal		gray	60 kΩ (fixed)	check electrode-to-skin connections
Electrode connected, impedance above limit		yellow	measured value (e.g. 15 kΩ)	check limit, check electrode-to-skin contact
Electrode connected, impedance at or below limit		green	measured value (e.g. 3 kΩ)	no action necessary

About Compressed Spectral Arrays (CSA)

The continuous EEG signal is sampled periodically and this value is stored in a frame. Each frame is processed using Fast Fourier Transformation (FFT) to provide a frequency spectrum displayed as a compressed spectral array (CSA).

The CSA window provides an overview of the patient's EEG values over time. It may be configured to look slightly different on your monitor.

- To view the CSA window permanently embedded on a Screen, select a Screen configured to display the CSA window.
- To view the CSA window over the current screen, select the **EEG CSA** SmartKey, if configured, or select **Setup EEG** or **Main Setup** then **Show CSA**.

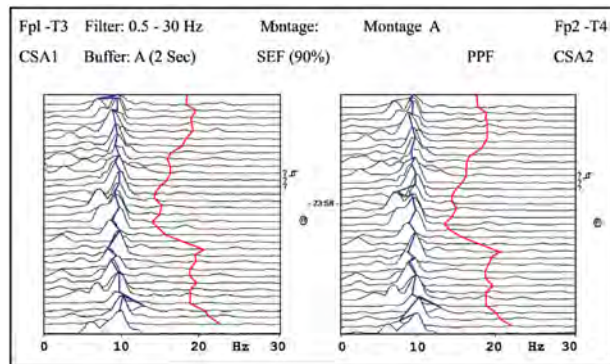

The CSA contains the following information		
Status line	Lead label	for example, Fp1-T3, Fp2-T4
	CSA label	CSA1 or CSA2 according to EEG channel
	Montage label	for example, Montage A
	Filter settings	for example, 0.5-30 Hz
	Buffer label and time	the buffer and interval between spectral lines on the CSA
	Current SEF Threshold	can only be changed in Configuration Mode
Spectral lines	The energy at each frequency is computed and displayed as a spectral line	
Trendlines	EEG values are sampled at configured time intervals and displayed as color-coded trendlines. Trendlines are available for the three frequency numerics (SEF, PPF, MDF)	
Annotations	?	INOP marker
	⏏	Filter change marker
	Ⓐ	Montage change marker

Changing CSA Settings

When CSAs are shown embedded on the Main Screen, select the CSA to show the pop-up keys. When the CSA is shown in a window over the current screen, the pop-up keys are always displayed.

Setup CSA Window	This menu entry lets you
Buffer	Choose one of the three pre-configured buffers. A buffer defines the interval between the spectral lines displayed in the CSA.

Setup CSA Window	This menu entry lets you
On/Off SEF On/Off MDF On/Off PPF	Switch the trendline of the specific numeric on or off.

Changing EEG Settings

Be aware that any changes made to EEG settings apply to both EEG channels.

Switching EEG Numerics On and Off

Each EEG numeric can be individually switched on or off in the **Setup EEG** menu.

- 1 In the **Setup EEG** menu, select the numeric label.
- 2 Select **On** or **Off** to switch between the settings.

Changing the Scale of the EEG Waves for Display

This only changes the visual appearance of the wave. It does not affect the signal analyzed by the monitor or printed in reports or recordings.

- 1 In the **Setup EEG** menu, select **Wave Scale** to call up a list of wave scales.
- 2 Select the required scale from this list.

Scaling information is displayed with each EEG wave.

- If **Show Gridlines** is set to **On** in Configuration Mode, gridlines and the current wave scale values are shown with the EEG wave.
- If **Show Gridlines** is set to **Off** in Configuration Mode, the current wave scale is indicated by a size bar beside the EEG wave.

Changing Filter Frequencies

The low and high pass filters screen out undesirable interference from the raw EEG wave display. The current EEG filter frequency settings are shown in the header of the CSA. Changing filter settings affects the EEG wave and all the EEG numerics. Whenever the filter setting is changed, a filter change marker appears next to the spectral lines.

To change the filter settings:

- 1 In the **Setup EEG** menu, select **Low Filter** or **High Filter** to call up a list of available frequencies.
- 2 Select the required frequency from this list.

Changing the Speed of the EEG Wave

The EEG measurement has its own speed control and is not affected by the wave speed settings of the other measurements.

In the **Setup EEG** menu, select **EEG Speed**. Choose the required speed from the pop-up list. This defines the speed at which the wave is drawn across the screen in millimeters per second (mm/s).

EEG Reports

The content of EEG Reports is always the same and does not need to be configured.

To print an EEG Report, in the **Setup EEG** menu, select **Print Report**.

Alternatively, you can select the CSA and use the **Print Report** pop-up key to start the report.

To modify the buffer and trendline settings on the CSA Report, in the **Reports** menu, select **CSA on EEG Rep..** If you do not change these settings, the monitor will use the default settings with the trendlines for the SEF numeric on and the buffer time from Buffer C.

CSA on EEG Rep.	This menu entry lets you
Buffer	Choose one of the three pre-configured buffer times.
Trend SEF Trend MDF Trend PPF	Switch the trendline of the specific numeric on or off.

EEG Safety Information

WARNING

Do not touch the patient, or table, or instruments during defibrillation.

When connecting electrodes and/or patient cables, ensure that the EEG leads and connectors do not come into contact with other conductive parts or earth.

High-frequency Surgery - To reduce the hazard of burns, the EEG electrodes should not be located between the surgical site and the electrosurgical unit return electrode.

EEG and Electrical Interference

CAUTION

Implanted devices (e.g. cardiac pace makers), other patient connected equipment, and other equipment near the patient (e.g. high-frequency surgical units) can cause interference on the waveform, numerics, and the CSA presentation.

Radiated field strengths above 1 V/m and patient signals $\leq 50 \mu\text{V}$ may cause noise on the EEG waves at various frequencies. Therefore, it is recommended to avoid the use of electrical radiating equipment in close proximity to the patient monitor. The noise does not influence the measurement accuracy.

Interference from ECG can be eliminated by adjusting the low filter settings.

Monitoring BIS

Bispectral Index monitoring helps to monitor the level of consciousness of a patient under general anesthesia or sedation in the OR and ICU. The BIS sensor is placed on the patient's forehead to capture electroencephalographic (EEG) signals from which several numerics are derived, including a single BIS value representing the level of consciousness. See the chapter on Specifications for the BIS intended use statement.

The BIS Module provides the monitor with an EEG wave and the following numerics:

Bispectral Index (BIS). The BIS numeric reflects the patient's level of consciousness. It ranges from 100 (fully awake) to 0 (suppression; no electrical brain activity).

Signal Quality Index (SQI). The SQI numeric reflects signal quality and provides information about the reliability of the BIS, SEF, TP, SR, and Bursts numerics during the last minute.

It ranges from 0 to 100%:

SQI < 15%: the numerics cannot be derived

SQI 15% to 50%: the numerics cannot be reliably derived

SQI 50% to 100%: the numerics are reliable.

Electromyographic Activity (EMG). The EMG numeric reflects the electrical power of muscle activity and high frequency artifacts.

EMG < 55 dB: this is an acceptable EMG

EMG ≤ 30 dB: this is an optimal EMG

(note that the minimum possible EMG is approximately 25 dB).

Suppression Ratio (SR). The SR is the percentage of time over the last 63-second period during which the EEG is considered to be in a suppressed state.

Spectral Edge Frequency (SEF). The SEF is the frequency below which 95% of the Total Power is measured.

Total Power (TP). The TP numeric indicates the power in the frequency band 0.5 to 30 Hz. The useful range is 30 - 100 dB.

Bursts (BISx used with the Extend sensor only). The Bursts numeric helps you quantify suppression by measuring the number of EEG bursts per minute, where an EEG burst is defined as a period of activity followed and preceded by inactivity (at least 0.5 second).

BIS Monitoring Setup

There are two BIS solutions available for use with the M1034A BIS module: using the Digital Signal Converter (DSC) and BIS Engine **or** using the BISx.

Monitoring BIS Using the DSC and BIS Engine

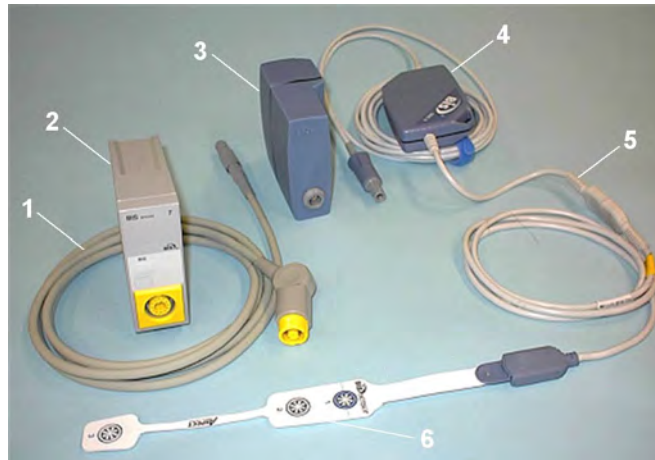

- 1 BIS Engine Cable
- 2 BIS Module
- 3 BIS Engine
- 4 Digital Signal Converter (DSC)
- 5 Patient Interface Cable
- 6 BIS Sensor

- 1 If you are monitoring BIS with the DSC and BIS Engine,
 - a. Connect the BIS Engine to the BIS module using the BIS Engine Cable.
 - b. Connect the digital signal converter (DSC) to the digital signal converter port on the front of the BIS Engine. Use the attachment clip to secure the digital signal converter near, but not above the patient's head.
 - c. Attach the patient interface cable (PIC) to the digital signal converter (DSC).
- 2 Attach the BIS sensor to the patient following the instructions supplied with the sensor. Make sure that the patient's skin is dry. Be aware that a wet sensor or a salt bridge may cause erroneous BIS and impedance values. A variety of sensors are available for use in the OR and ICU environments.
- 3 Connect the BIS sensor to the patient interface cable. As soon as a valid sensor is detected, the impedances of all electrodes are measured automatically and the results are shown in the BIS window.

Monitoring BIS using the BISx



- 1 BIS Module
- 2 BISx
- 3 Patient Interface Cable
- 4 BIS Sensor

- 1 If you are monitoring BIS using the BISx,
 - a. Connect the BISx to the BIS module
 - b. Use the clip on the rear of the BISx to affix it in a position convenient for your patient, not above the patient's head.
- 2 Attach the BIS sensor to the patient following the instructions supplied with the sensor. Make sure that the patient's skin is dry. Be aware that a wet sensor or a salt bridge may cause erroneous BIS and impedance values. A variety of sensors are available for use in the OR and ICU environments.

CAUTION

Ensure that the BISx does not come into prolonged contact with your patient's skin, as it may generate heat and cause discomfort.

The BISx may remain connected to a patient during defibrillation as long as the sensor is not located between the defibrillator pads.

- 3 Attach the patient interface cable (PIC) to the BISx.
- 4 Connect the BIS sensor to the PIC.

As soon as a valid sensor is detected, the impedances of all electrodes are measured automatically and the results are shown in the BIS window.

Manufacturer's Information

BIS Engine, DSC, BISx, the Patient Interface Cable and the BIS Sensors are manufactured by Covidien llc.

BIS Continuous Impedance Check

This checks:

- the combined impedance of the signal electrodes plus the reference electrode.
This is done continuously and does not affect the EEG wave. As long as the impedances are within the valid range, there is no notification of this check or its results.
- the impedance of the ground electrode.
This is done every ten minutes and takes approximately 4 seconds. It causes an artifact in the EEG wave, and the message **Ground Check** is shown on the monitor screen during the check. If the ground electrode does not pass this check, another check is started. This continues until the ground electrode passes the check.

If the Continuous Impedance Check interferes with other measurements, it can be switched off. To do this:

- 1 In the **Setup BIS** menu, select **Cont. Imp. Check**.
- 2 Select **On** or **Off** as required.

CAUTION

Switching the continuous impedance check off will disable automatic notification to the user of impedance value changes, which may lead to incorrect BIS values. Therefore, this should only be done if the check interferes with or disturbs other measurements.

BIS Cyclic Impedance Check

This measures the exact impedance of each individual electrode. It causes a disturbed EEG wave, and the INOP **BIS ImpedanceCheck** is shown on the monitor screen during the check.

Starting a Cyclic Impedance Check

The Cyclic Impedance Check is automatically started when a sensor is connected. To manually start a Cyclic Impedance Check:

- select **Sensor Check** in the **Setup BIS** menu to toggle between **On** and **Off**, or
- select **Start Sensor Chk** in the BIS window.

Stopping a Cyclic Impedance Check

The Cyclic Impedance Check stops automatically if the impedances of all electrodes are within the valid range. To manually stop a Cyclic Impedance Check:

- select **Sensor Check** in the **Setup BIS** menu to toggle between **On** and **Off**, or
- select **Stop Sensor Chk** in the window.

If you stop a Cyclic Impedance Check before the ground electrode has passed, a ground electrode impedance check will be started automatically. This cannot be switched off.

BIS Window

To open the BIS window, in the **Setup BIS** menu, select **Show Sensor**.

The window may look slightly different on your monitor. The graphic in the BIS Window automatically adapts to show the type of sensor you are using, showing three or four electrodes as required. Each symbol in the graphic represents an electrode and illustrates the most recently-measured impedance status of the electrodes. Although BIS may still be measured when the electrode status is red or yellow, for best performance, all electrodes should be green.

In addition, if the measured electrode-to-skin impedance of any electrode or electrode combination is above the limit, or if disconnected electrodes are detected, an INOP will be issued, either **BIS High Impedance** or **BIS Lead Off**.

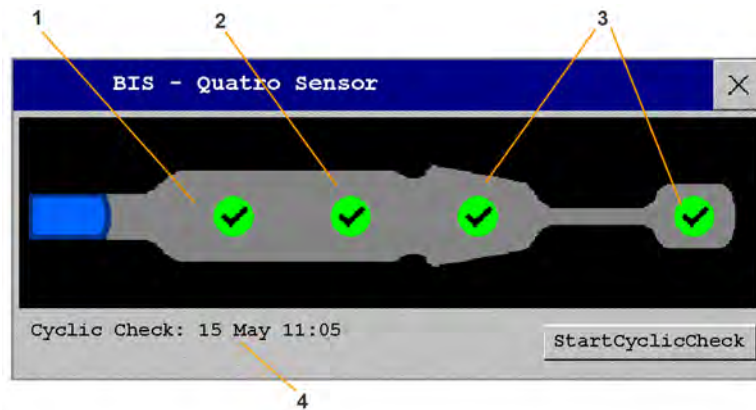

- 1 Reference Electrode
- 2 Ground Electrode
- 3 Signal Electrode(s)
- 4 Time of the most recent cyclic check

BIS Impedance Indicators

Electrode-to-Skin Impedance	Symbol	Color	Action
Electrode has no skin contact		red	Reconnect electrode, or check the sensor-to-skin contact. If necessary, clean and dry skin.
Too much signal noise, impedance cannot be measured		gray	Check sensor-to-skin contact. Press sensor more firmly to skin. If necessary, clean and dry skin.
Impedance above limit		yellow	Check sensor-to-skin contact. Press sensor more firmly to skin. If necessary, clean and dry skin.
Impedance within valid range		green	No action necessary

Depending on your configuration, in addition to the symbols, the impedance value in kOhm may be displayed.

Changing the BIS Smoothing Rate

The smoothing rate defines how the monitor averages the BIS value.

To change the smoothing rate, in the **Setup BIS** menu, select **Smoothing Rate** then choose either:

- **15 sec:** this provides increased responsiveness to changes in the patient's state.
- **30 sec:** this provides a smoother BIS trend with decreased variability and sensitivity to artifacts.

Switching BIS and Individual Numerics On and Off

To switch the BIS measurement on or off:

- In the **Setup BIS** menu, select **BIS** and then **On** or **Off** as required.

To switch individual numerics provided by the BIS Module on or off:

- In the **Setup BIS** menu, select **SQI**, **TP**, **SEF**, **SR**, **EMG**, or **Bursts** and then **On** or **Off** as required.

Changing the Scale of the EEG Wave

Changing the scale only changes the visual appearance of the wave. It does not affect the signal analyzed by the monitor or printed in reports or recordings.

The scale information shown depends on whether gridlines are switched on or off for display. This setting can only be changed in Configuration Mode.

- 1 In the **Setup BIS** menu, select **Scale** to call up a list of wave scales.
- 2 Select the required scale from this list.
 - When gridlines are switched off, you can choose from the available scale values: 50 μV , 100 μV , 200 μV , and 500 μV . Scaling information is displayed as a vertical bar on the EEG wave together with its height equivalent in μV .
 - When gridlines are switched on, scales are defined as a range, either $\pm 25 \mu\text{V}$, $\pm 50 \mu\text{V}$, $\pm 100 \mu\text{V}$, or $\pm 250 \mu\text{V}$. Scaling information is shown in the form of gridlines.

Switching BIS Filters On or Off

The low and high pass filters screen out undesirable interference from the raw EEG wave display. The notch filter removes line frequency interference. Filter settings affect the EEG wave and the SEF and TP values, but they do not affect the BIS, EMG, SR, and SQI values.

The filter settings are set in Configuration Mode. You can switch all the filters on or off together in Monitoring Mode.

- 1 In the **Setup BIS** menu, select **Filters**.
- 2 Select **On** or **Off** as required.

BIS Safety Information

For information on the use of BIS in specific monitoring situations and on pharmacological responses to the anesthetic agents Nitrous Oxide (when used as the sole anesthetic agent), Ketamine, and Etomidate, contact Covidien to request a copy of their publication "A Clinician's Guide to the Bispectral Index".

Considerations for Use

Due to limited clinical experience in the following applications, BIS values should be interpreted cautiously in patients with known neurological disorders, those taking psychoactive medications, and in children below the age of 1.

WARNING

Conductive Parts: The conductive parts of sensors and connectors should not contact other conductive parts, including earth.

High-frequency Surgery: To reduce the hazard of burns in the high-frequency surgical neutral electrode connection, the BIS sensor should not be located between the surgical site and the electrosurgical unit return electrode.

Defibrillation: The BIS sensor must not be located between defibrillator pads when a defibrillator is used on a patient connected to the patient monitor.

Securing Cables: To minimize the risk of patient strangulation, the patient interface cable (PIC) must be carefully placed and secured.

CAUTION

Revisions: The system will only function if all component revisions are compatible. Otherwise, an incompatibility INOP is displayed.

If the DSC has an older software revision than the BIS Engine, the DSC will automatically be upgraded by the BIS Engine. Do not disconnect the DSC from the BIS Engine, or disconnect the BIS module from the monitor, or switch the monitor power off within the first ten seconds after connection, as this will disrupt a possible software upgrade and cause damage to the DSC.

Impedance Checks: Impedance checks may influence data acquisition of other electroencephalographic devices.

Monitoring NMT

Neuro Muscular Transmission (NMT) and its measurement enables the evaluation of muscle relaxation of patients under Neuromuscular Block by measuring the strength of muscle reaction after electrically stimulating the dedicated motor nerve. The NMT Monitor electrodes are placed on the patients skin over the ulnar nerve, a controllable current source delivers stimulation pulses to two skin surface electrodes for the nerve stimulation, the muscle response is measured with an acceleration sensor.

WARNING

The NMT measurement may not be used for neonatal patients and is therefore not supported in the neonatal mode.

NMT stimulation current pulses may interfere with other sensitive equipment, for example, implanted cardiac pacemakers. Do not use the NMT measurement on patients with implanted medical devices unless so directed by a medical specialist.

Simultaneous use of the NMT with high frequency electrosurgical equipment may in unusual circumstances result in burns at the stimulation site and can also adversely affect measurement accuracy.

Do not use the NMT in close proximity to shortwave or microtherapy devices, there is a risk of adversely affecting the NMT measurement.

Explosion Hazard: Do not use in the presence of flammable anesthetics or gases, such as a flammable anesthetic mixture with air, oxygen or nitrous oxide. Use of the device in such an environment may present an explosion hazard.

Never apply the electrodes trans-thoracically (across the chest) or transcerebrally (across the head), there is a risk of seriously injuring the patient. Apply the stimulation electrodes close together as described in the Instructions for Use.

Never apply electrodes to patients in areas where inflammation or injury is evident.

When you are connecting the electrodes or the patient cable, make sure that the connectors **do not, and cannot,** come into contact with other conductive parts, or with earth.

Never touch the electrodes unless the stimulation has been stopped.

Patients with nerve damage or other neuromuscular problems may not respond properly to stimulation. The NMT measurement may show unusual patterns when monitoring muscle paralysis in these patients.

After repositioning the patient, check that the sensor is still applied and can move freely.

CAUTION

NMT monitoring is intended as an adjunct in patient assessment and must be used in conjunction with observation of clinical signs and symptoms.

NMT stimulation can be painful to a non-sedated patient. It is recommended not to stimulate before the patient is adequately sedated.

Use only electrodes suitable for nerve stimulation deemed appropriate by the attending physician. Pay special attention to current densities exceeding 2 mA r.m.s./cm^2 for any electrodes.

Stimulation Modes

The NMT module provides four stimulation modes:

- Train-Of-Four (**TOF**)
- Single Twitch (**Twitch**)
- Post-Tetanic Count (**PTC**)
- Double-Burst Stimulation (**DBS**)

Train-Of-Four (TOF)

In this mode four stimuli are applied every 500 milliseconds (2 Hz). Each stimulation of the train causes the muscle to contract. The fade in the individual response to each single stimulation provides a basis for evaluation. The NMT Module then calculates a TOF ratio (**TOFrat**) value in % using the ratio between the fourth and the first twitch. When fewer than four twitches are detected, the monitor displays a TOF count (**TOFcnt**) value instead, this represents the number of responses to the four TOF stimulation pulses.

Post-Tetanic Count (PTC)

The Post-Tetanic Count stimulation pattern starts with a sequence of four current pulses, delivered every 500 milliseconds (2 Hz). If a muscle response is detected, the PTC sequence is stopped and the responses are reported as TOF measurement. If there is no muscle response, the sequence continues with a five seconds long tetanic stimulation of current pulses delivered at 50 Hz, followed by a pause of 3 seconds, followed by 20 single current pulses delivered every second (1 Hz). Muscle response detection is active only during the first 4 single pulses and the last 20 single pulses. During the last 20 pulses, the **PTC** value is incremented with each detected muscle response.

Single Twitch (Twitch)

If this mode is configured the NMT Module measures the response to single electrical stimuli applied to peripheral motor nerves. The module sends a single pulse and measures the strength of the resulting twitch, the module then calculates a Twitch Ratio (**Twitch**) value in %. If the displayed numeric is 80, the strength of the measured twitch was 80% of that of the reference twitch, see “Calibrating the NMT Measurement” on page 296.

Double-Burst Stimulation (DBS)

The Double-Burst stimulation pattern consists of a sequence of 3 current pulses delivered every 20 milliseconds (50 Hz), followed by a pause of 750 milliseconds, followed by another sequence of 3 current pulses delivered every 20 milliseconds (50 Hz). With each detected muscle response the DBS Count (**DBScnt**) value is incremented.

Preparing to Measure NMT

The IntelliVue NMT Module is intended to be used only with adult and pediatric patients.

Skin Preparation for Electrode Placement

Good electrode-to-skin contact is important for a good stimulation pulse. Insufficient cleaning of the skin can cause high skin resistance which could cause the stimulation to stop.

- 1 Select sites with intact skin, without impairment of any kind.
- 2 Clip or shave hair from sites as necessary.
- 3 Wash sites thoroughly with soap and water, leaving no soap residue.
Do not use ether or pure alcohol as this dries the skin and increases the resistance.
- 4 Dry the skin thoroughly.

Placing the NMT Electrodes and Transducer

Stimulation of the ulnar nerve in the wrist is preferred for routine monitoring.

CAUTION

To avoid unintentional electrical shocks always make sure that the NMT stimulation has been stopped before touching the electrodes.

NOTE

Ensure that the thumb can move freely before applying the NMT sensor.

Place the electrodes on the prepared site over the ulnar nerve on the palmar side of the wrist; refer to the figure below.

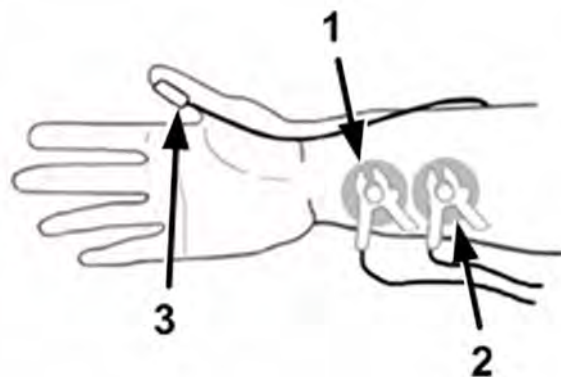

- 1 Black cable clamp
- 2 Red cable clamp
- 3 Transducer

- 1 Place the distal electrode near the wrist.
- 2 Place the proximal electrode 2 to 3 cm proximal to the distal electrode.
- 3 Attach the Black cable clamp cable to the distal electrode, (see figure above).
- 4 Attach the Red cable clamp cable to the proximal electrode, (see figure above).
- 5 Place and affix the transducer with a large flat side against the palmar side of the thumb. The cable should be attached in such a way that it does not 'pull' at the transducer and that movement of the thumb is not obstructed. The more distal the transducer is placed on the thumb, the stronger the acceleration signal.

CAUTION

Make sure that the lead wires cannot come into contact with external pacemaker or catheter wires.

Arm Position

The arm used for the NMT measurement, should be kept immobile during the whole procedure.

Taking NMT Measurements

NOTE

Both the NMT calibration and NMT measurement cannot be started:

- When the parameter (NMT) is switched off
- During the recovery phase after a measurement.
- During an ongoing automatic measurement cycle.
- During an ongoing calibration
- When error conditions have been detected.
- When no patient cable is connected.

Calibrating the NMT Measurement

With the NMT calibration the supramaximal stimulation current is determined and the reference twitch is set to 100%. The reference twitch is the twitch at the supramaximal stimulation current when the patient is not paralyzed. This must be done prior to administration of Neuromuscular Blocking Agents (NMBA).

If the NMT Module is unable to establish a reference twitch, it uses an internal reference value for single-twitch measurements.

NOTE

It is recommended that the patient be anesthetized before setting up the calibration twitch as nerve stimulation can be painful.

Starting Calibration

- 1 Either press the NMT key on the module, or select the numeric on the screen to enter the **Setup NMT** window.
- 2 Select **Start Cal.**

3 Select **Confirm**.

This automatically determines the supramaximal stimulation current and takes the reference twitch (100%) at this current. If the NMT Module is unable to establish a reference twitch, it uses an internal reference value for single-mode measurements.

Clearing a Reference Twitch

Clearing the Reference Twitch resets the supramaximal stimulation current and reference twitch to default values. To clear the stored references:

In the **Setup NMT** window:

- 1 Select **Clear Reference**.
- 2 Select the **Confirm** key to reset the stored supramaximal stimulation current and reference twitch to the default values.

NOTE

This function is not available if a calibration is in progress or no calibration data is stored.

CAUTION

Changing the stimulation current or pulse width also clears stored references.

Starting/Stopping NMT Measurements

To Start NMT measurements, in the **Setup NMT** window select the start key for the mode used, (for example, **Start TOF**).

If you need to change the NMT settings after startup, stop the measurements, change the settings, then restart the measurements.

To Stop NMT measurements, in the **Setup NMT** window select **Stop**, the measurement is immediately interrupted.

NOTE

To stop NMT stimulation in an emergency, disconnect the NMT patient cable from the NMT Module.

During an automatic measurement cycle the yellow Start/Stop LED on the NMT Module is lit. If the automatic cycle is stopped, or the measurement mode is set to manual the LED is off.

The LED flashes (in both modes) when a stimulation pulse is given.

CAUTION

To avoid unwanted electrical shocks **DO NOT** touch the electrodes when the yellow Start/Stop LED is flashing on the NMT module.

NOTE

Take care when removing the transducer from the patient. Do not pull on the cable.

Changing the NMT Measurement Settings

Selecting the NMT Stimulation Mode

In the **Setup NMT** window:

- 1 Select **Stimulation** to enter the Stimulation window.
- 2 Choose the Stimulation mode required:
 - **TOF**
 - **PTC**
 - **Twitch** (if configured)
 - **DBS** (if configured)

Measurement Mode

Allows the choice between manual and automatic NMT measurements.

In the **Setup NMT** window:

- 1 Select **Mode** to open the Mode window.
- 2 Select **Auto** or **Manual** mode.

NOTE

Auto mode is not available if the **PTC** or **DBS** stimulation mode is selected.

Selecting the Repeat Time (only available in Auto mode)

Repeat Time allows you to select the time intervals between automatic NMT measurements.

NOTE

This function is not available in the **PTC** and **DBS** mode.

In the **Setup NMT** window:

- 1 Select **Repeat Time** to open the Repeat Time window.
- 2 Select the required setting.

Selecting the Stimulation Current

To set the stimulation current.

In the **Setup NMT** window:

- 1 Select **Current** to open the Current window.
- 2 Select the required setting.
- 3 If you are modifying a previously calibrated current, select **Confirm**.

CAUTION

Changing the stimulation current after calibration invalidates the stored reference data.

Selecting the Pulse Width

Setting a Pulse Width sets the duration of the stimulation pulse.

In the **Setup NMT** window:

- 1 Click on **Pulse Width** to open the Pulse Width window.
- 2 Select the required setting.
- 3 Select **Confirm** if you wish to modify a previously calibrated pulse width.

CAUTION

Changing the stimulation pulse after calibration invalidates the stored reference data.

Value Lifetime

Displays the time after which an NMT numeric value disappears from the resting display.

The **Value Lifetime** setting is visible (grayed out) in the **Setup NMT** window. The setting can only be changed in the Configuration Mode.

NMT Tone Volume

Enters a list of selections to adjust the audio volume of the NMT stimulation tone. If not zero, each NMT stimulation pulse is indicated by a short beep.

You can change the **NMT Tone Volume** in the **Setup NMT** window.

Alarms

TOFcnt High Limit Alarm

In the **Setup NMT** window:

- 1 Select the **TOFcnt High Lim.**
- 2 Select limit: 0, 1, 2, 3.

NMT Alarm Suppress

Depending upon your configuration, the **TOFcnt** high alarm maybe suppressed until the **TOFcnt** value has reached 0 for the first time. This setting can only be changed in the Configuration Mode.

Understanding NMT Numerics

Numerics

TOF ratio (**TOFrat**), TOF count (**TOFcnt**), Twitch ratio (**Twitch**) and DBS Count (**DBScnt**) numerics show the result of an NMT measurement. Together with these numerics either the time the measurement was taken or the time until the next measurement is shown. The extended numeric representation shown will only be available when using a screen designed to show it. The relative strength of individual muscle responses, as measured by the acceleration sensor are displayed as a bar graph.

Dependent upon the selected stimulation mode, the following information is provided:

Stimulation Mode	Numeric Label	Unit	Trend	Number of Bars
Single-Twitch	Twitch	%	None	1
Train-Of-Four	TOFrat	%	Yes	4
	TOFcnt			
Post-Tetanic-Count	PTC		Yes	1...20
Double-Burst	DBScnt		None	2

Auto mode

The figure below shows the NMT measurement in **Auto** mode.

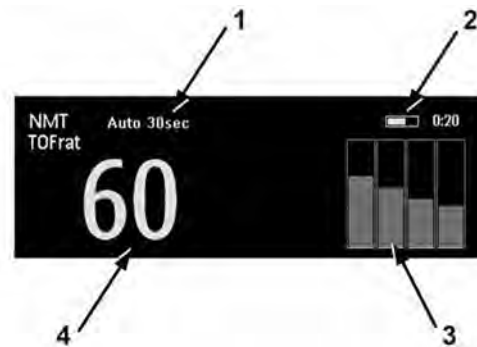

- 1 NMT: **Auto** mode, **Repeat Time** 30 sec.
- 2 Time until next measurement or the time the measurement was taken.
- 3 Bar graph showing relative strength of each twitch. If a calibration has been made, the strength of the calibration reference twitch is shown as a white line.
- 4 **TOFrat** expressed as %.

Manual mode

The figure below the NMT measurement in **Manual** mode.



- 1 NMT: **Manual** mode, (there is no **Repeat Time**).
- 2 Time the measurement was taken (**Timestamp**).

Recovery Time

Most NMT stimulation modes require a minimum neurophysiological recovery time and during this recovery phase no new stimulation can be started. Also, you cannot start a measurement or calibration.

Guardian Early Warning Scoring

MX400/450/500/550 Using an MX400/450/500/550 monitor with the appropriate option, you can use Guardian Early Warning Scoring to get an early warning score based on vital signs and clinical observations collected at intervals.

The goal of an early warning score is to help you recognize the early signs of deterioration in patients. Depending on the score calculated, an Action List with appropriate recommendations is displayed. There are no dedicated alarms associated with an Early Warning Score.

This functionality is highly configurable, to allow customization for the vital signs and observations collected and the type of scoring used. Due to this configurability, your screens will probably not exactly match the screens shown here. The workflow described here uses the special configuration delivered with the monitor; if this configuration has been changed, you will not have all the possibilities described.

WARNING

When using Guardian Early Warning Scoring, request a printout of the EWS scoring table and the Action Lists from your configuration expert. Use them to verify that the configuration of the scoring functionality matches your hospital's requirements.

The IntelliVue Information Center will not display or trend any of the entered observations, the early warning score, or the action list, but can pass these on to other connected systems.

Performing the Scoring Procedure

- 1 To run Guardian Early Warning Scoring (EWS) you need to switch to the EWS/SpotCheck Screen (or another Screen configured to show EWS).
 - a. Select the current Screen name in the monitor info line.
 - b. Select your EWS Screen from the list.Or select the **EWS/SpotChk** SmartKey, if configured.

- If required, enter your operator data with a barcode scanner.

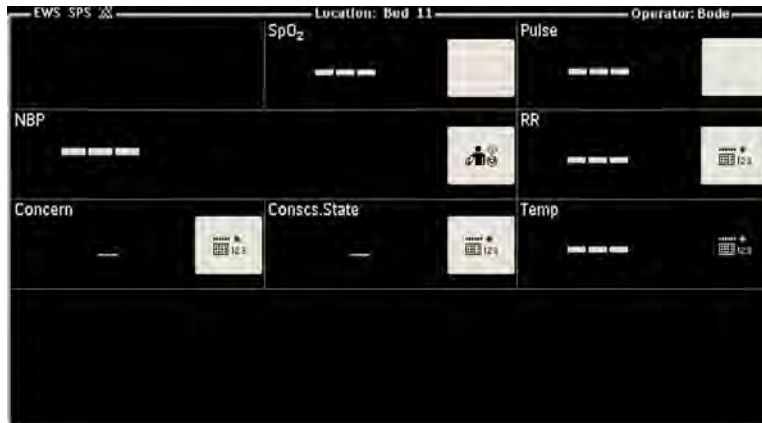

- Start collecting vital signs and entering observations. If the patient is continuously monitored, any relevant currently measured vitals will appear automatically in the EWS Screen. Other vitals may be measured by the monitor, or may need to be entered manually:

- If NBP is not yet displayed on the screen, start a blood pressure measurement with the start key.
- If SpO₂ is not already being measured, apply the SpO₂ sensor and a short time later the value will appear in the SpO₂ box on the screen. Moving dashes are displayed until the measured value is available.
- If the pulse rate is not already displayed from a continuously measured HR, SpO₂, or NBP, it will appear as soon as a blood pressure or SpO₂ measurement has been made.
- Any vital sign or clinical observation you need to enter manually is indicated by a keyboard symbol. Select the symbol to enter the missing data.



All vital signs and clinical observations with a white box are **required**, i.e. they must all be entered for a complete SpotCheck record. If a keyboard symbol or start key is not in a white box, the corresponding vital sign or clinical observation is optional.

When values have already been entered or measured, an existing white box will disappear.

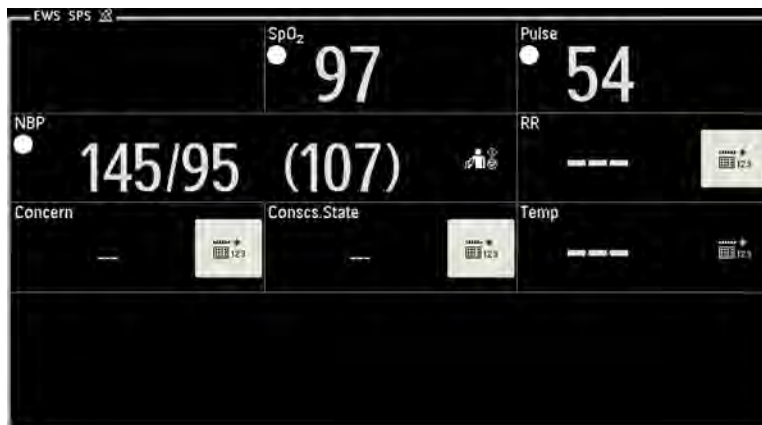

One complete set of vitals and observations, together with the calculated score(s), is referred to as a SpotCheck record. Once all the required vitals have been entered or measured, the SpotCheck record will be automatically stored after the configured freeze time.

If you want to store values before the end of the freeze time, you can select **Store Vitals**, to store the values and close data collection. The **Store Vitals** key can also be used to store an incomplete set of vitals at any time.

If you want to break off the Early Warning Scoring process without storing the SpotCheck record, use the **Clear VS** key.

- 4 To leave the EWS procedure and return to your standard monitoring screen, select the appropriate screen from the screen list, or select the **Previous Screen** SmartKey (if configured).

WARNING

Alarms: There will be no alarm indications for measurements in the entry screen.

Values: The values shown in the entry screen do not have the same annotation as the measurement values on other monitor screens. There is no special indication when a value has been manually entered and no timestamp showing when the value was measured/entered. Be aware that values will remain visible until the freeze time is at an end, even when the measurement itself is no longer providing current values.

Understanding Guardian Early Warning Scoring

An early warning score is an assessment aid used to help recognize the early signs of deterioration in medical patients. There are two basic types of scoring:

- **Single Parameter Scoring (SPS)** - A score is given for each of the vitals based on the measured/entered value. Each vital sign has upper and lower thresholds assigned and the score registers the status as either "inside the thresholds" (normal) or "outside the thresholds" (requires action). When one of the vitals measured or entered is outside of the thresholds, an action is recommended.
How does SPS work in Guardian Early Warning Scoring? SPS results in a color-coded circle displayed next to the measured or entered values. The circle is white for the normal range and red for outside of the thresholds. **As soon as one of the values crosses a threshold**, a corresponding action will be recommended in the action list in the lower part of the screen. If several vitals have values outside of the thresholds, this will result in a list of actions.
- **Modified Early Warning Scoring (MEWS)** - A subscore is given for each of the vitals based on the measured or entered value. When all the required vital signs have been entered or measured, the subscores are added together to give the MEWS score. Each subscore has a color coding, to indicate the level of risk associated with it, for example:

Normal	White	Subscore 0
Observe - at risk	Yellow	Subscore 1
Warning	Orange	Subscore 2
Urgent	Red	Subscore 3

The MEWS score also uses the same color coding and risk levels, which determine the action that is recommended.

How does MEWS work in Guardian Early Warning Scoring? MEWS results in a subscore displayed in a circle with the corresponding color, next to each measured or entered value. **Actions are only then recommended when all required vitals have been measured or entered**, and the MEWS score has been calculated. The content of the action list depends upon the risk band severity the MEWS score falls into. For each risk band severity (Normal, Observe - at risk, Warning and Urgent) a separate action list can be configured.

Which Type of Scoring is Being Used?

The type of scoring used in your department, whether it is SPS or MEWS, or a combination of both, was configured during your system setup. Normally, the configuration is based on an assessment method already in use before the system was set up. Which vitals are needed for scoring, and which actions are recommended for specific scores or risk bands, was also configured individually. Independent of the type of scoring used, there may be additional vital signs or clinical observations which are configured to be included in the entry screen. They do not contribute to scoring but are included in the SpotCheck record.

Viewing EWS Trend Data

To view trend data, select the **SpotChk Trend** SmartKey. A tabular trend will be shown, with all measured and entered data and any calculated scores. You can use the up arrow and down arrow keys to scroll through the list of Spot Check records.

Date	Time	MEWS	HR/PIs	NBP	Temp	RR	AVPU
22 Jul	12:51	3	58	152/95 (109)	41.0	16	Voice
22 Jul	11:51	1	53	141/103 (110)	41.0	30	Unresp..
22 Jul	11:51	1	52	141/103 (110)	41.0	30	Unresp..
22 Jul	11:50	1	125	141/103 (110)	40.0	30	Unresp..

- 1 This symbol indicates that more information is available than can be shown on the Screen. Select the tabular trend to page through the remaining data columns.

Select the **Graph/ Tabular** pop-up key to view the data in graphical form. If any MEWS records are present, they will be displayed in the color-coded risk bands (2) in the lower half of the graphical trend. The MEWS score ranges corresponding to the colored bands are shown in the scale on the right. Other record types, such as SPS, are displayed in the notification area (1). The symbols used are explained in “Symbols Used in the Trend Views” on page 305.







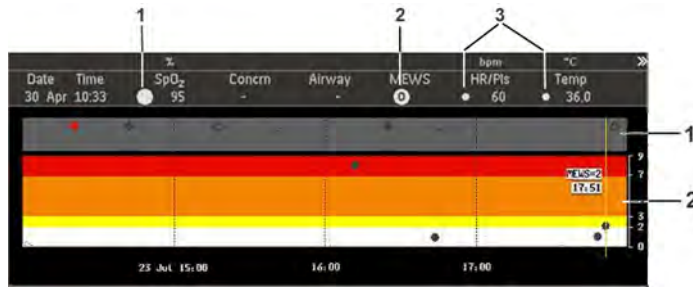



Select the **Detailed View** pop-up key to see a combined graphical/tabular view for the currently highlighted record. Use the cursor keys (right arrow and left arrow) to move from one record to the next. The detailed data are shown above the graphical trend, with units and the corresponding SPS or MEWS symbols. In the example below:

- 1 Colored circle for SPS data
- 2 MEWS score symbol (color coded according to the risk level)
- 3 MEWS subscore symbol (color coded according to the risk level)



Symbols Used in the Trend Views

The following symbols can appear in the trend views:

Symbol	Indicates
	SPS SpotCheck record - normal range
	SPS SpotCheck record - outside of normal range
	Manual SpotCheck record
	MEWS SpotCheck record
	MEWS score (color depends on the risk level)
	SpotCheck record triggered by a deterioration
	SpotCheck record triggered by an alarm
	SpotCheck record from an automatic vital signs measurement

Making Recordings

The trend data can be sent to a recorder using the recording pop-up keys.

- **Record Selected** makes a recording for the selected SpotCheck record.
- **Record 8 h** makes a recording for the last 8 hours of data.
- **Record All** makes a recording of all available SpotCheck records.

At the beginning of the recording, the title, the type of recording and the time will be printed. If available, the patient's name, date of birth, ID and the type of scoring (protocol name) currently active will also be printed.

Using Different Types of Scoring

If your department has more than one type of scoring configured, for example one type for patients receiving oxygen and one for patients not, you can switch from one type to another.

To switch to a different scoring protocol, depending on which screen is currently displayed, either:

- 1 Select the  symbol.

- 2 Select **Protocol**.
 - 3 Select the required protocol from the list.
- or
- 1 Select **Main Setup**.
 - 2 Select **ProtocolWatch**.
 - 3 Select **Protocol**.
 - 4 Select the required protocol from the list.

Using a Telemetry Device and a Monitor (PIC only)

It is possible to assign a monitor and a telemetry device to the same patient, resulting in the information from both devices being combined in one sector at the Information Center. This is called "pairing" and when a telemetry device and a monitor are paired, the measurement data from the telemetry device will be displayed on the monitor screen.

A telemetry device can be:

- any Philips telemetry device (only for indirect connections, see below).
- a TRx/TRx+ Intellivue Telemetry system transceiver.
- an X2 Multi measurement module with a telemetry interface, declared as a telemetry device and with a telemetry equipment label.

For complete user information, including accessory listings and specifications, for the M4841A/M4851A TRx/TRx+ IntelliVue Telemetry Transceiver, refer to the Instructions for Use provided with the device.

How Can You Combine Devices?

- With an **indirect** connection, using standard telemetry transmission - the data are sent to the monitor via the Information Center and arrive with a delay of several seconds at the monitor.
- With a **direct** connection to the monitor
 - an X2 is connected via MSL cable to the monitor, **or**
 - a telemetry transceiver with a short range radio adapter is assigned to an X2 which is connected (Companion Mode) to an MX400/450, MX500/550, or MX600/700/800 host monitorthe data arrive with a minimal delay on the monitor screen.

Indirect Connection - Manual Pairing

The telemetry device can be paired with the monitor at the Information Center or at the monitor. For detailed information regarding pairing and configuration at the Information Center, see the Information Center Instructions for Use.

To pair the monitor with a telemetry device at the monitor:

- 1 Select **Main Setup** then **Measurements**

2 Select **Telemetry**

The **Setup Telemetry** menu will appear with only one entry **Paired Equipment**.

3 Enter here the equipment label of the telemetry device to be paired.

Pairing at the monitor is only possible when the monitor already has a connection to the Information Center and the Information Center software version allows pairing at the monitor.

Own Patient Overview Window

The measurements from the telemetry device are shown in the own patient overview window on the monitor. See “Own Patient Overview Window” on page 122

Direct Connection - Automatic Pairing

The following direct connections are possible:

- an X2, declared as a telemetry device, and connected with an MSL cable to a monitor.

WARNING

- When ECG is being measured with a telemetry device directly connected to the monitor, there will be no ECG signal available at the ECG analog output or ECG Sync Pulse output and no synchronization marks on the ECG wave. A **No ECG Out** message will appear in the ECG wave channel.
 - When a telemetry device is connected to the monitor, arrhythmia relearning is initiated, and again when the telemetry device is disconnected.
 - Controls on the Telemetry Device (e.g. nurse call) will be inactive when the device is directly connected to the monitor except in the case when the monitor has no network connection and data are transferred via the telemetry device.
-

Pairing an X2 With a Telemetry Interface to a Host Monitor

An X2 Multi-measurement module using an IntelliVue Instrument Telemetry interface will be automatically paired when it is connected to a host monitor and it has been declared as a "telemetry device" at the Information Center.

When the X2 is disconnected from the host monitor it will remain paired and the measurement data will appear at the host monitor in the Telemetry Data window. After the X2 is disconnected from the monitor it may take over 15 seconds until their data is displayed at the Information Center.

Pairing of a host monitor and a telemetry device, with all the related functionality, is only possible when the **host monitor** is using a wired LAN connection or a wireless LAN interface (but not using the IntelliVue Instrument Telemetry interface).

The X2 can also be manually paired to a host monitor without a direct connection, as described in “Indirect Connection - Manual Pairing” on page 307.

Refer also to “Use Models With Telemetry” on page 309 for further related use modes.

Unpairing the Monitor and Telemetry Device

If the patient will no longer be monitored with the telemetry device, or only with the telemetry device and no longer with the monitor, you need to end the device pairing. After unpairing, the Information Center will receive data exclusively from the monitor or from the telemetry device:

- select the **Unpair To Mon.** SmartKey to end pairing and have the Information Center receive the measurement data from the monitor



- select the **Unpair To Tele** SmartKey to end pairing and have the Information Center receive the measurement data from the telemetry device

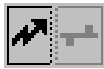

or

use the Unpair function at the Information Center.

NOTE

The SmartKeys and pop-up keys for unpairing appear only on the monitor which is directly involved in pairing.

Use Models With Telemetry

The standard use model combining a monitor and a telemetry device involves pairing the two devices so that the data measured by the telemetry device appears on the monitor screen - and at the Information Center in the same patient sector as the monitor data. The following variations are possible:

- 1 The monitor is paired with a telemetry transceiver - indirect connection
 - telemetry data appear on the monitor
- 2 An X2 is declared as a telemetry device and paired with an MX400/MX450, MX500/MX550, or MX600/700/800 monitor - direct or indirect connection
 - X2 measurement data appear on the monitor it is paired with
 - a telemetry transceiver cannot be used with the X2
- 3 A telemetry transceiver directly connected via SRR to an X2, that is connected (via Companion Mode) to an MX400/450, MX500/550, or MX600/700/800 monitor - direct connection
 - telemetry data appear on the **host monitor**
 - telemetry transceiver is paired with the host monitor but is assigned to the X2
 - **the X2 must have no equipment label**

The different variations require different configuration settings; refer to the Configuration Guide for details.

Trends

Trends are patient data collected over time and displayed in graphic, tabular or histogram form to give you a picture of how your patient's condition is developing. Trend information is stored in the trends database for continuously-monitored measurements, such as ECG, as well as for aperiodically-measured parameters, such as noninvasive blood pressure.

Viewing Trends

Trend information can be viewed embedded as a screen element on specially-designed Screens, or you can open a trend window over the current Screen.

- To view trends embedded as a screen element, enter the **Change Screen** window, then select a Screen designed to show an embedded trend window.
- To open the tabular trends window over the current Screen, select **Main Setup, Trends**, then

Vitals Trend, or select the **Vitals Trend** SmartKey .

- To open the graphic trends window over the current Screen, select the **Graph Trend** SmartKey



- To open the histogram trend window over the current screen, select **Main Setup, Trends**, then **Histogram**, or select the **Histo-gram** SmartKey.







The trend windows open displaying the most recent data and are updated as new data is stored. A timescale along the bottom or the top of the screen shows you where you are in the trends database. The preview column on the right-hand side shows the latest available measurement value. The preview column is updated every five minutes or whenever an NBP or other aperiodic measurement is completed.

A question mark (?) beside a value means that the data may not be reliable, due perhaps to an INOP condition in the measurement.

Your monitor screen may look slightly different to the examples shown in this chapter.

Trends Pop-Up Keys

When you open the graphic, tabular or histogram trends window, a selection of pop-up keys appears to let you navigate through the stored trend data and carry out trends-related tasks.

Pop-Up Keys	Selecting this pop-up key lets you....
Select Group	see a pop-up list of trend groups and select a group for viewing.
Select Interval	see a pop-up list of available data resolution settings and select the level of detail shown in the trend view.
Print/ Record	print a tabular trends report or make a tabular trend recording of the data in the current window. The report will use the current trend interval settings.
Print	print a graphic trends report or histogram report of the data in the current window. The report will use the current trend interval settings.
	move the cursor one step to the left or right to navigate through the trends database timeline.
	move the cursor one page to the left or right to navigate through the trends database timeline.
	jump to the beginning or the end of the trends database to see the most recent or oldest trend information stored.
	scroll up and down the screen to see measurement trends that do not fit in the current view.
Vital Signs	open the current trend view in tabular form. The displayed time period and resolution stay the same.
Graph Trend	open the current trend view in graphic form. The displayed time period and resolution stay the same.
Data Source	select a realtime SpO ₂ or realtime system pulse or trended data for display in the histogram.
Period	select a time period for the histogram.
Select Range	define the range of values to be displayed in the histogram by selecting an upper and a lower limit.
Column	select a column width for the histogram. For each width selection the resulting number of columns is shown.
Curve On/Off	switch the display of the cumulative value columns in the histogram on or off.
Adjust Cursor	open a new set of pop-up keys for switching on cursors and setting their positions.

Viewing Graphic Trends



A cursor spanning all measurements in the trend group helps you to navigate through the trends database and shows you your current position in the database. When the cursor is moved across the time line, the values measured at the cursor time are shown in the right hand column.

In graphical trends, aperiodic measurement trends are shown as an asterisk, NBP has a special symbol.

To use the trend cursor to navigate in time through the trends database,

- 1 Select the graphical trend or the arrow pop-up keys to activate the cursor.
- 2 Use the arrow pop-up keys to move the trend cursor backwards and forwards in time, or
- 3 Place the cursor at a specific time by touching the graph.

Viewing Vital Signs Trends

Parameter	15:29	15:30	15:31	15:32	15:33	15:34	15:35	15:36	15:37	15:38
HR	60	60	60	60	60	60	60	60	60	60
SpO ₂	95	95	95	95	95	95	95	95	95	95
NBP*	---	---	---	---	---	---	---	---	---	120
NBPd	---	---	---	---	---	---	---	---	---	80
NBPm	---	---	---	---	---	---	---	---	---	90
etCO ₂	30	30	30	30	30	30	30	30	30	30
imCO ₂	0	0	0	0	0	0	0	0	0	0
RR	---	---	---	---	---	---	---	---	---	15
awRR	30	30	30	30	30	30	30	30	30	30
ABP*	120	120	120	120	120	120	120	120	120	120
ABPd	70	70	70	70	70	70	70	70	70	70
ABPm	91	91	91	91	91	91	91	91	91	91
PAP*	28	28	28	28	28	28	28	28	28	28
PAPd	15	15	15	15	15	15	15	15	15	15
PAPm	21	21	21	21	21	21	21	21	21	21

- 1 Aperiodic values are shown with a timestamp

The currently-selected column is highlighted. The values can be configured to display in the same colors as the waves and numerics on the realtime display.

Any values available for display before the next scheduled update are shown in the right hand column, with a timestamp in brackets.

If more than one value is available for an aperiodic trend for a certain trend period, all measured values are stored in the database and the value closest to the timestamp is shown in the Vital Signs display marked with an arrow.

To view the Vital Signs trend with one column for each NBP measurement (see “Defining the Column Interval Using the NBP Measurement” on page 317):

- 1 With the Vital Signs trend open, select **Interval**.
- 2 Select **NBP** from the pop-up list.

Viewing Histogram Trends

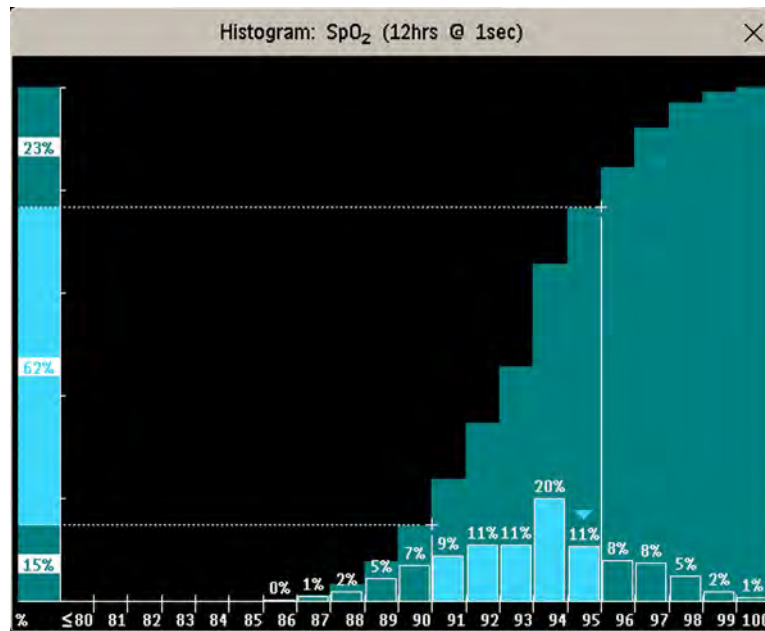

The title line of the window shows the label of the trended measurement and the resolution of the data; in the SpO₂ histogram above, 1 second realtime samples.

The horizontal axis shows the range and unit of the displayed measurement. The vertical axis shows the percentage of time.

The columns in the foreground show how much of the time the measured values fell into this range on the scale. For example, in the histogram above, the SpO₂ value was between 93 and 94% during 20% of the last 12 hours. The display of the percentage value above each column, can be switched on or off by selecting the histogram. The arrow mark over a column shows that the currently measured value is also in this range. The columns are displayed in the same color as the measurement data.

The columns in the background show the cumulative percentage value: each of the foreground columns is added to the sum of those columns to the left of it. The cumulative columns can be switched off using the **Curve On/Off** pop-up key.

A question mark is displayed if less than two-thirds of the data are valid samples.

The pop-up keys in the window can be used to change the measurement, the time period and the range. You can also print out a histogram report.

The SpO₂ and System Pulse histograms can use trended data or realtime data with 1 second samples.

Using Cursors

You can set two cursors that span a "corridor", for example to divide a histogram into in-range and out-of-range areas. Or you can set both cursors to the same value and use them as one cursor to divide the histogram into an upper and a lower segment.

The cursors are represented by a vertical line from the x-axis and a dotted horizontal line from the y-axis. When two cursors are used, they can be locked using **Lock/ Unlock**, so that the distance between them is fixed. Moving a cursor will then move both together. Select **Lock/ Unlock** again to separate the cursors and move them independently again.

A summary column on the y-axis shows the lower, middle and upper ranges as determined by the cursor positions. When only one cursor is used there will be a lower and an upper range. Color shading is used to differentiate the ranges in the cumulative column and to highlight the columns between the cursors.

Setting Up Trends

Trends are set up in Configuration Mode. You can make temporary changes to trends settings such as trend groups, priorities, or scales in Monitoring Mode. The general settings for all Trends are under **Main Setup, Trends**.

Settings for a single segment in graphical trends or for the corresponding trend group can be made more easily in that segment menu.

Making Segment Settings

The **Graphical Trends** window is divided into measurement segments, each of which has its own settings.

To enter the segment menu,

- select the left hand column of the segment, where the measurement label is displayed.

Expanded View

To expand the segment to fill the **Graphical Trends** window,

- in the **Segment** menu, select **Expand** to have that segment enlarged to fill the window.

In the expanded view, you can also highlight a measurement to make it more easily visible (for example when multiple ST trends are in one segment). To highlight a measurement,

- in the **Segment** menu, select **Highlight** repeatedly until the highlight is on the required measurement.

To return the segment to its original size,

- in the **Segment** menu, select **Expand** again.

Trend Scales for Segment Measurements

To change the trend scales for a measurement in the current segment:

- 1 In the **Segment** menu, select the measurement label.
- 2 Select **Upper** to change the upper limit of the scale or **Lower** to change the lower limit of the scale.

Optimum Scale

To have the monitor automatically select an optimum scale for viewing, based on current values,

- in the **Segment** menu, select **Optimum Scale**.

This scale change is temporary. When the graphical trend window is closed the scale reverts back to the setting in **Parameter Scales**.

To switch off automatic optimum scaling,

- in the **Segment** menu, select **Optimum Scale** again.

Trend Group

To add or remove measurements for this trend group or change the order of the existing measurements:

- 1 In the **Segment** menu, select **Change Group**.
- 2 Use the **Add, Change, Sort Up** and **Sort Down** pop-up keys to change or re-order the group as required.

No. of Segments

In an embedded graphical trend window, you can select the number of segments to be displayed in the **Segment** menu:

- In the **Segment** menu, select **No. of Segments**.

Trend Groups

The measurements grouped in trend groups define the trends displayed together in the **Vital Signs** or **Graphical Trends** windows and printed in trends reports and recordings. The sequence of the measurements in the group defines the order in which they are displayed. Measurements listed between dotted line separators are displayed overlapping. The trend group **All** contains all available measurements, you cannot change the order or selection of this group.

To change the selection of measurements in a trend group, either use the **Change Group** setting in the **Segment** menu or:

- 1 Select **Main Setup, Trends**, then **Trend Groups**.
- 2 Select the Trend Group you want to change and use the pop-up keys to **Add, Change**, or **Delete** the selection of measurements trended.

To temporarily change the order in which the measurements are displayed in a group,

- 1 Select **Main Setup, Trends**, then **Trend Groups**.
- 2 Select the Trend Group and then the measurement you want to move and use the **Sort Up/Sort Down** pop-up keys.

Trend Interval

The trend interval defines the resolution of trend data shown on the Screen. High-resolution data is especially suited for neonatal applications, where the clinical situation may change very quickly. In adult monitoring, where the patient's status typically changes more gradually, a longer trend may be more informative.

To set the trend resolution, in the **Vital Signs** or **Graphical Trends** window,

- Select the **Select Interval** pop-up key and then select the required interval from the list.

Trend Priority

The monitor stores trend information for all monitored measurements, if configured to do so. (Data from VueLink or IntelliBridge modules cannot be included in trends when the label is a free-text label.)

If your configuration restricts the number of measurements trended, you must choose which measurements will be included. A priority list is used to select the trended measurements.

To see the measurement priority list for trending,

- 1 In the **Main Setup** menu, select **Trends**.
- 2 Select **Trend Priority**.

To add measurements to the priority list,

- 1 Select the pop-up key **Add** and choose from the pop-up list of available measurements.
- 2 Use the **Sort Up** and **Sort Down** pop-up keys to change the priority order.

Trend Parameter Scales

Parameter scales define how the trend waveform will appear on the screen and in trend reports. Separate scales can be set for adult, pediatric, and neonatal patient trends.

To change the trend parameter scales settings, either use the **Scale** setting in the **Segment** menu or:

- 1 In the **Main Setup** menu, select **Trends**.
- 2 Select **Parameter Scales**.
- 3 Select the measurement or parameter you want to change from the list.
- 4 Select the pop-up key **Change** to call up the **Scale** menu.
- 5 In the **Scale** menu, select the parameter label you want to define settings for. Select **Adult**, **Pedi**, and **Neo** and use the pop-up keypad to enter new upper and lower scale definitions.

Graphical Trend Presentation

Graphical trends and screen trends for measurements with compound values (for example ABP or CO₂) can be viewed in line or band form.

To change the presentation style,

- 1 Select **Main Setup** then select **Trends**.
- 2 Select **Global Style** and choose
 - **Line** to display the trends as a continuous line
 - **Band** to fill the area between the trend lines, for example, between the systolic and diastolic pressures, with color.

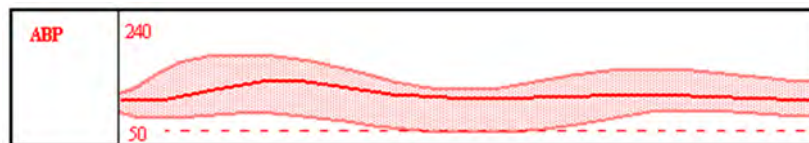

This sample ABP trend shows the continuously-measured values for the systolic, diastolic and mean pressures displayed in band form.

Defining the Column Interval Using the NBP Measurement

You can have the NBP measurement determine the interval between the columns on the Vital Signs trend. Each NBP measurement will generate a column in the trend table. The values for the other measurements are added to the column to provide a complete vital signs set for the NBP measurement time.

To use the NBP measurement to determine the column interval:

- 1 Select **Main Setup** then **Trends**.
- 2 In the **Trends** menu, select **Setup VitalSigns**.
- 3 In the **Vital Signs** menu, select **Column** and then **NBP** from the pop-up menu.

Making Settings for Histograms

To make settings for histograms, first display the **Trends** window by selecting **Main Setup** then **Trends**.

Setting the Default Measurement

To set the default for the measurement data to be used in the histogram, in the **Trends** window,

- 1 Select **Setup Histogram**.
- 2 Select **Data Source**.
- 3 Select either
 - **Realtime Data**, and then a realtime SpO₂ or Pulse, or
 - **Trended Data** and then select the required measurement from the trended data list.

Setting the Default Period

To set the default period for the histogram, in the **Trends** window,

- 1 Select **Setup Histogram**.
- 2 Select **Select Period** and select the required time period from the list.

Setting the Unit for the Data Source

To set the unit for the selected measurement data source, in the **Trends** window,

- 1 Select **Setup Histogram**.
- 2 Select **Unit** and select a unit from the list.

Switching Cumulative Value Columns On and Off

To switch the display of the cumulative value columns on or off, in the **Trends** window,

- 1 Select **Setup Histogram**.
- 2 Select **Curve On/Off**.

Setting the Range for the Measurement

To set the range to be displayed on the x-axis, in the **Trends** window,

- 1 Select **Setup Histogram**.
- 2 Select **Range**, then enter a value for the lower end of the range and the upper end of the range.

Displaying Percentages on Columns

To switch the display of the percentage values above the columns on or off, in the **Trends** window,

- 1 Select **Setup Histogram**.
- 2 Select **Column Value**.

Switching the Cursor On and Off

To switch the cursor and the summary column on or off, in the **Trends** window,

- 1 Select **Setup Histogram**.
- 2 Select **Cursor**.

Setting Initial Cursor Positions

To set the positions of the cursors, in the **Trends** window,

- 1 Select **Setup Histogram**
- 2 Select **Cursor Range** then enter a value for the upper and lower cursors. If both have the same value only one cursor will be shown.

When viewing a histogram, the data source, the period, the range, the column width, the display of the cumulative value columns and the cursor positions can be changed using the pop-up keys.

Documenting Trends

To print a Vital Signs or Graphical Trends report,

- in the **Vital Signs** or **Graph Trends** window, select the pop-up key **Print** to print a report for the trend group currently on the monitor screen.

Reports include the most recent information in the trends database and extend backwards in time according to the selected trend interval and your monitor's configuration. Trends reports can be printed on central or local printers.

To make a Vital Signs recording,

- in the **Vital Signs** window, select the **Print/ Record** pop-up key, then select the **Record Vitals** pop-up key.

Vital Signs recordings print the trend data for the current group and trend period shown in the **Vital Signs** window.

Trends Databases

Depending on the purchased options and the monitor's configuration, the trends databases store information for up to 100 measurements for up to 96 hours.

The values in the trends database are stored as measured by the monitor, they are not averaged values. The trend resolution defines how often a value is stored. In general, if more than one value is available for storage in the trends database, the most recent value is used. Some values in the trends are marked with arrows. This indicates that for this time period, more values were available and the most recent one is shown.

Example database configuration

In this example, we see that the monitor stores the most recent data at the highest resolution, older data are stored at a lower resolution.

"4 hours @ 12 second resolution" means that the monitor stores trend data every 12 seconds, for the most recent four hours.

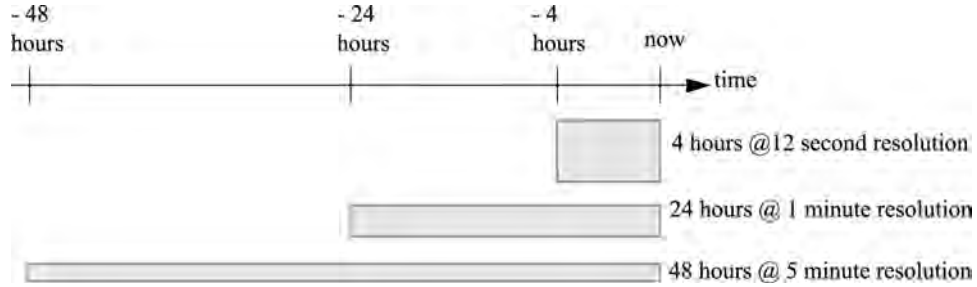

Aperiodic Trends Database

Aperiodic trends do not count toward the maximum number of trends allowed by the trend configuration. Trend data for aperiodic measurements is stored in a separate database and timestamped with the measurement time.

Trending Multiple-Value Measurements

Some measurements generate multiple values, for example invasive pressure measurements can provide systolic, diastolic, and mean values. These values are trended as separate measurements.

Screen Trends

Trends configured to display permanently on special monitor Screens are called screen trends. The selection and number of measurement waves in the Screen Trend segment depends on your monitor configuration. Screen trends are color-coded to match the measurement wave and numerics, and they can be viewed in graphical, tabular, histogram or horizon format.

If you do not see screen trends on the monitor Screen, select a different Screen, one that is configured to show screen trends. Screen trends are only available on specially designed Screens.

Screen Trend information is taken from the Trends database. If you do not see a Screen Trend for a particular measurement on the Screen, check the trend priority list to ensure that this measurement is being trended.

Setting the Screen Trend Time

To set the **ScreenTrend Time** for all graphical, histogram and horizon screen trends ("global" trend time),

- 1 Select a screen trend then select **Setup Trend**, or select **Main Setup** then select **Trends**.
- 2 Select **ScreenTrend Time** and select the required time: 30 minutes, one, two, four, eight, or twelve hours.

This is now the Global screen trend time and defines the period of trend information shown for all screen trends.

To set a different **ScreenTrend Time** for a screen trend or a group of aligned screen trends,

- 1 Select a screen trend.
- 2 Select **Change TrendTime**.
- 3 Select the required trend time.
Selecting **Global** leaves the trend time set to the global screen trend time.

Changing the Selection of Screen Trends Displayed

- 1 Select the screen trend.
- 2 Select **Change Trend** and select the required trend from the list of available trends.
Select **Blank** to remove the selected trend from the Screen.
If you do not see **Change Trend** in the screen trend menu, the trend is aligned to display with the measurement wave. Changing the wave automatically changes the trend.

To display two or more screen trends overlapping,

- 1 Select the screen trend to open the screen trend menu,
- 2 Select **Change Trend** followed by **Add Trend** and select a screen trend from the pop-up list.

Activating the Cursor for Screen Trends

To activate the cursor for Screen Trends:

- 1 Select the screen trend.
- 2 Select **Activate Cursor**.

You can now use the arrow keys to move the cursor across the time line. The values measured at the cursor time are shown next to the cursor.

To de-activate the cursor,

- Select **Main Screen**.

Changing the Screen Trend View

To switch between tabular, graphic, histogram and horizon views, select the screen trend then select **Change View** and select the required view.

Tabular View

Aperiodic measurements such as NBP, C.O., C.I., and Wedge can be viewed as a screen trend in tabular form. The measured values and their timestamps are shown, with the measurement label.

The trend time for tabular screen trends depends on the space available on the Screen. Up to 30 measurements or 12 hours information can be shown.

Histogram View

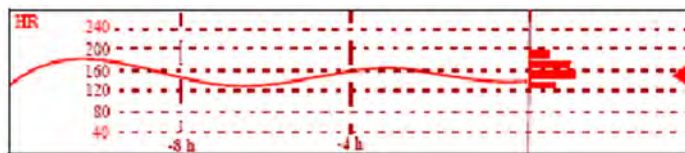

The histogram view presents a combination of graphical trend and histogram. The histogram is on the right hand side in a horizontal presentation with vertical gridlines representing 25%, 50%, 75% and 100%. Each column shows the percentage of time that the measurement values were in a specific range. This range is represented by the column's position in the graphical trend gridlines. The arrow mark next to a column shows that the currently measured value is in the range covered by that column.

If less than two-thirds of the samples are valid, a question mark will be displayed with the histogram, except when the histogram consists of intermittently measured data.

Horizon View

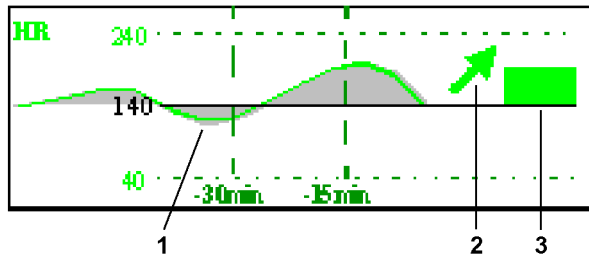

The horizon view presents trend information superimposed over a defined baseline or base range. This helps you visualize changes in your patient's condition since the baseline was set.

The horizon view is made up of:

- a horizon, drawn in white, as a reference point or baseline to help you visualize changes in your patient's condition. The horizon can be set to represent your patient's current condition, or a target condition and can be a single value or a range.
- a graphical trend, displaying patient data for the set TrendTime (1).
- a trend indicator arrow, indicating how the patient trend has developed in the set time period (10 minutes, 5 minutes or 2 minutes) (2).
- a deviation bar, showing how the currently measured value deviates from the set horizon (3). The height of the deviation bar is an indication of the extent of the change in your patient's condition relative to the (horizon) baseline.

Your monitor may not be configured to show all elements of the screen trend horizon view.

Setting the Horizon

The horizon is the reference value to which deviations in the measurements are compared.

- 1 To set the horizon, select the horizon trend.
- 2 Select
 - **Set High Horizon** to select the upper horizon value. If the high and low horizon values are the same, the horizon is a baseline - if the values are different the horizon is a range.
 - **Set Low Horizon** to select the lower horizon value.
 - **Auto Horizon** to set the horizon for the selected horizon trend to the currently-measured value.
 - **Auto All** to reset the horizon for all horizon screen trends to the currently-measured values.
 - **Set Horizon** to set the horizon to a specific value from a pop-up list.

Setting the Horizon Trend Scale

The horizon trend scale is defined with respect to the horizon. If your horizon is set to 100 and you select 20 as the horizon scale delta, the upper limit of the horizon scale will be 120 and lower limit 80.

To set the horizon trend scale delta,

- 1 Select the horizon trend.
- 2 Select **Set Scale Delta** and select a value to define the distance between the horizon and the upper and lower scale limits.

Be aware that changing the horizon trend scale can change the angle of the trend indicator, without the patient's condition having changed.

If a measurement exceeds the outer limits of the scale, the wave will be clipped and you must either reset the horizon or the horizon trend scale to display the values outside the scale limits.

Setting the Time Period for the Trend Indicator Arrow

The time period for which the trend indicator arrow is displayed can be set in the **Trends** window.

- 1 Select **Main Setup** then select **Trends**.
- 2 Select **HorizonArrowTime**.
- 3 Select 10, 5 or 2 minutes.

Calculations

Calculations are patient data that is not directly measured but calculated by the monitor when you provide it with the appropriate information.

Your monitor can perform the following hemodynamic, oxygenation, and ventilation calculations.

Hemodynamic	Oxygenation	Ventilation
Cardiac Index (C.I.)	Arterial Oxygen Content (CaO ₂)	Minute Volume (MINVOL)
Stroke Volume (SV)	Venous Oxygen Content (CvO ₂)	Compliance (COMP)
Stroke Index (SI)	Arteriovenous Oxygen Content (CavO ₂)	Dead Space (Vd)
Systemic Vascular Resistance (SVR)	Oxygen Availability Index (DO ₂ I)	Dead Space/Tidal Volume Ratio (Vd/Vt)
Systemic Vascular Resistance Index (SVRI)	Oxygen Consumption (VO ₂)	Alveolar Ventilation (ALVENT)
Pulmonary Vascular Resistance (PVR)	Oxygen Consumption Index (VO ₂ I)	
Pulmonary Vascular Resistance Index (PVRI)	Oxygen Extraction Ratio (O ₂ ER)	
Left Cardiac Work (LCW)	Alveolar-Arterial Oxygen Difference (AaDO ₂)	
Left Cardiac Work Index (LCWI)	Percent Arteriovenous Shunt (Qs/Qt)	
Left Ventricular Stroke Work (LVSW)		
Left Ventricular Stroke Work Index (LVSWI)		
Right Cardiac Work (RCW)		
Right Cardiac Work Index (RCWI)		
Right Ventricular Stroke Work (RVSW)		
Right Ventricular Stroke Work Index (RVSWI)		
Extra Vascular Lung Water Index (EVLWI)		
Intrathoracic Blood Volume Index (ITBVI)		
Global End Diastolic Volume Index (GEDVI)		

The hemodynamic calculations available depend on the Cardiac Output measurement method being used and the regulatory standards that apply for your hospital: see the “Monitoring Cardiac Output” chapter for availability details.

Viewing Calculations



- Select the **Calcs** SmartKey to open the **Calculations** window.
- Select the **Calc Type** field and select the required calculation type for display.

Calculations Windows

This example calculations window shows the **Hemodynamic Calculations** window. The ventilation and oxygenation windows are similar.

Hemodynamic Calculations						×	
Height	75 in	Calculation Time					
Weight	125.0 lb	BSA	1.80 m ²	19 Apr 13:56			
C.O.	8.00 l/min			C.I.	4.44 l/min/m ²		
HR	80 bpm	SV	100.0 ml	SI	55.6 ml/m ²		
ABPs	86 mmHg	SVR	510 DS/cm ⁵	SVRI	918 DS/m ² /cm ⁵		
ABPd	54 mmHg	PVR	80 DS/cm ⁵	PVRI	144 DS/m ² /cm ⁵		
ABPm	65 mmHg	LCW	4.7 kg-m	LCWI	2.6 kg-m/m ²		
PAPs	38 mmHg	LVSW	58.5 g-m	LVSWI	32.5 g-m/m ²		
PAPd	26 mmHg	RCW	1.74 kg-m	RCWI	0.97 kg-m/m ²		
PAPm	30 mmHg	RVSW	21.76 g-m	RVSWI	12.09 g-m/m ²		
PAWP	22 mmHg						
CVPm	14 mmHg						

- 1 **Height** used for the calculations
- 2 **Weight** used for the calculations
- 3 **Calculation Time**
- 4 Calculations input values
- 5 Output values
- 6 Indexed calculation values

Calculations Pop-Up Keys

Depending on the calculations group you choose, a selection of pop-up keys will appear to let you navigate through the stored events and carry out calculations-related tasks.

Pop-Up Keys	Selecting this pop-up key lets you....
Resample Vitals	use the most recent monitored values. Resampling sets the calculation time to the current time, and displays the corresponding values for the previous second.

Pop-Up Keys	Selecting this pop-up key lets you....
Perform Calc	perform the displayed calculation using the currently-input values and store the calculation in the calculations database
Print/Record	print or record the displayed calculation.
On/Off DateTime	toggle between showing the date and time or the units for the calculation input values.
On/Off Ranges	toggle between showing the normal ranges or the units for the calculation output values.
Cardiac Output	access the C.O. procedure window.
Hemo Review	open the hemodynamic calculations review window.
Vent Review	open the ventilation calculations review window.
Oxygen Review	open the oxygenation calculations review window.

Reviewing Calculations

To enter the calculations review window, select the **Oxygen Review**, **Vent Review**, or **Hemo Review** pop-up key as required.

The review window lists all the input and output values for each measurement in the calculations group. The timeline in the review window lists the times the calculations were performed.

To review individual calculations, select the calculation in the review window and then select the **Original Calc** pop-up key.

The storage time for calculations is the same as the trend database storage time configured for the monitor. So if trends are stored for 48 hours, the calculations will also be stored for 48 hours.

Performing Calculations

You must check that all input values are appropriate for your patient before performing calculations.

- 1 Select the **Calcs** SmartKey to open the **Calculations** window.

- 2 Check the calculation time in the **Calc Time** field.

When you enter the calculation window, this field will show either the current time or the time of the most recent available C.O. measurement, depending on your monitor configuration.

- To choose a different calculation time, select the **Calc Time** field. This calls up a list showing the timestamps of calculations performed earlier. Select a time from this list, or select **Select Time** to enter a time of your choice. The values from the Vital Signs database from the 30 minute period before the selected time will be used.
- To enter the current time, select the **Resample Vitals** pop-up key. If you choose the current time, the monitor will resample all the required values that are monitored.

- 3 Enter any values that must be entered or edited manually. Select the value field and then use the pop-up keypad to enter the required values. Select **Enter** to confirm each entered value. Manually-entered values are marked with an asterisk (*).

Entering Values for Calculations

The monitor automatically enters any available values for calculations. For aperiodically-measured values such as C.O., the monitor will re-use the most recent value in the calculation database until a new value becomes available. If the calculation time is the last C.O. time, values will be used from up to and including 30 minutes before the C.O. time, except for height and weight where the last available value will be used.

- To enter calculations values manually or edit automatically-entered values, select the value field to open the on-screen keyboard and use this to enter the correct value. Values edited manually are marked with an asterisk (*).

If you enter a value that has more decimal places than allowed for a particular input, the value you enter will be rounded off after you select **Enter**. If you enter a value which cannot be stored, the message **Value out of range** will appear. Enter a new value.

In hemodynamic calculations, if the systolic and diastolic pressures are manually entered, the mean pressure is calculated and marked with an asterisk (*). The formula used to estimate the mean pressure is:

$$[\text{systolic} + (\text{diastolic} \times 2)] / 3.$$

Automatic Value Substitution

If the monitor cannot find a value required for calculation, it automatically tries to find an equivalent source for this value. For example, if C.O. is required but unavailable, the monitor automatically looks for CCO as a alternative source of C.O. values, or an alternative Pressure label may be used instead of ABP. The label of the value in the **Calculations** window does not change. Substituted values are marked with an asterisk (*).

If a PAWP value is not available, PAWP will be set to zero in the formulas where it is used.

Automatic Unit Conversion

The monitor needs consistent units for performing calculations. It automatically converts units where necessary before it performs the calculation, for example, pressures sourced in kPa, cmH₂O, or mbar are automatically converted to mmHg, or to cmH₂O for ventilation calculations.

Manual Unit Conversion

If you need to convert units for other purposes you can use the **Unit Conversion** window:

- 1 Select **Main Setup** then select **Calculations**.
- 2 Select **Unit Conversion**.
- 3 Select the field under the unit you know and use the on-screen keypad to enter the known value. The converted value automatically appears in the adjacent field.

BSA Formula

Your monitor provides both the Boyd and Dubois formulas for the calculation of body surface area (BSA). For calculations, the monitor uses the setting defined in the **Patient Demographics** menu. All calculation results that use BSA are indexed to the selected formula.

- To check the current setting, select the patient name to enter the **Patient Demographics** menu. **BSA(B)** indicates that the Boyd formula is used; **BSA(D)** indicates that the Dubois formula is used.

Comparing Dynamic Compliance Values

If you compare the dynamic compliance value (COMP) from the ventilation calculations with the value from the Spirometry measurement you may see a difference. This comes from the different sampling methods:

- The algorithm in the ventilation calculations takes into account only two sets of paired AWP/AWV data: those from complete expiration and complete inspiration, when AWF is zero.
- The algorithm in the Spirometry application takes into account all sets of paired AWP/AWV data (125 Hz sampling rate), over one complete breath cycle, and calculates an "averaged" compliance using a least square method.

Documenting Calculations



To send a Calculations recording to a connected recorder, in the **Calculations** window, select the **Print/ Record** pop-up key, then select the **Record Calc** pop-up key.

Calculations recordings print the patient demographic information and the content of the current **Calculations** window on the recorder strip.

To print a report for the calculation group currently on the monitor screen, select the pop-up key **Print Calc**. To print the review window, select the pop-up key **Print** in the review window. All the calculations in the current group will be printed in the report.

Calculation reports can be printed on central or local printers.

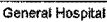
This example report shows the oxygen calculation group. Ventilation and hemodynamic calculation reports are similar.

1	Bob Jones		123456	
2	Oxygen Calculations			
	Calculation Time 4 Apr 02 12:24			
	Time	Units	Range	Units
	C.O.	3.61 12:21	1.6-2	17.20 ml/dl
	FIO2	*0.85 12:24	0.8-2	12.14 ml/dl
	PaO2	*50 12:24	5-5	4.2-5.0 ml/dl
	PaCO2	*55 12:24	5-5	950.1150 ml/min
	SpO2	*80 12:24	%	198 ml/min
	PvO2	*35 12:24	mmHg	O2ER 0.44-0.28
	SvO2	*53 12:24	%	AaDO2 50-52
	Hb	*15.0 12:24	g/dl	Qs/Qt 3.5 %
	FB	*760 12:24	mmHg	
	Height	185 12:24	cm	
	Weight	85.0 12:24	kg	BSA 2.09 m2
3				DO2I 550.650 ml/min/m2
				VO2I 115.165 ml/min/m2
	  			

- 1 Patient information
- 2 Calculation group
- 3 Three columns of calculations input and output values, with times, units and ranges, where appropriate

High Resolution Trend Waves

High resolution (hi-res) trend waves provide information for fast-changing parameters at a glance. They can help you to recognize trend patterns and to find interrelationships between measurements, by comparing changes in your patient's condition across different hi-res trend waves.

The amount of data you can show on a screen depends on the display size and resolution: for example, on an eight inch (20 cm) wave trace on your monitor screen, you can view approximately six minutes of hi-res trend wave trace. The hi-res waves are drawn at a speed of 3 cm/minute.

The availability of hi-res trend waves depends on your monitor configuration and on the options purchased for your monitor.

Changing the Hi-Res Trend Waves Displayed

To change the selection of hi-res trend waves on the Screen:

- 1 Select a displayed hi-res trend wave.
- 2 Select the required hi-res trend wave from the pop-up list.

If there are no hi-res trend waves on the Screen, you must change to a Screen with hi-res trend waves.

Hi-Res Trend Wave Scales

Hi-res trend waves are either compressed realtime waves or fast numeric trends.

- Hi-res trend waves from compressed realtime waves include: Resp, CO₂, ABP, PAP, CVP, ICP, AWP, anesthetic agents.
- Hi-res trend waves from fast numeric trends include: btbHR, SpO₂, tcpO₂, tcpCO₂, Pulse, Perf, CPP, BIS, CCO, inO₂, Delta SpO₂.

Hi-res trend waves from realtime waves use the wave scale as their display scale. Changing the wave scale changes the hi-res trend wave scale.

Hi-res trend waves from numerics use a pre-defined display scale dependent on the patient category.

Hi-Res Trend Waves and OxyCRG

OxyCRG is a combination of three hi-res trend waves, btbHR, SpO₂, and Resp, mainly used in neonatal monitoring.

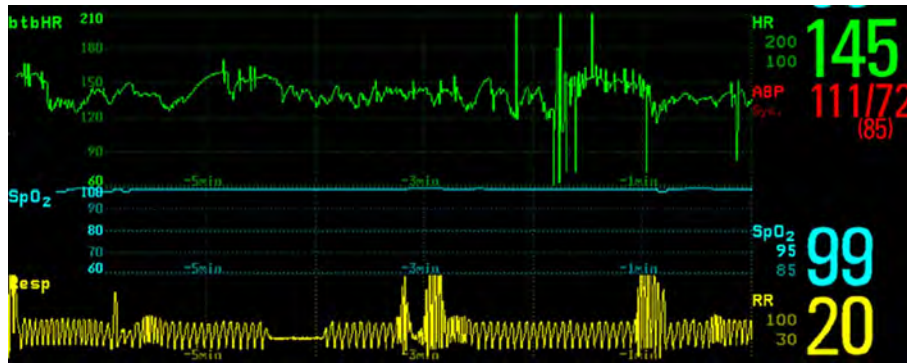

Printing Hi-Res Trend Wave Reports

To print hi-res trend waves on reports, you can choose to print either

- all **VisibleWaves** - prints all waves and hi-res trend waves currently displayed
- **All Waves** - prints realtime waves and hi-res trend waves for all currently-monitored measurements
- **HiRes Waves** - prints hi-res trend waves for the currently-monitored measurements
- **OxyCRG Waves** - prints hi-res trend waves for btbHR, SpO₂, and Resp.

For each hi-res trend wave, a maximum of six minutes of measurement data will be printed.

See the “Printing Patient Reports” chapter for more information on setting up reports.

Hi-Res Trend Wave Recordings

The selection of waves in hi-res trend wave recordings and the recording speed are defined by the pre-configured HiResTrd recording template. See “Recording” on page 357 for more information.

To start a hi-res trend waves recording,

- 1 select the **Recor- dings** SmartKey, if configured, or select **Main Setup** then select **Recordings**.
- 2 select the **HiRes Recordng** pop-up key.

Event Surveillance

Events are electronic records of episodes in your patient's condition. You can trigger them manually, or set them to trigger automatically during pre-defined clinical situations.

Depending on the level of event surveillance available on your monitor, the information stored for each event episode can include:

- waveforms for up to four measurements of your choice (depending on episode type, see “Events Pop-Up Keys” on page 335 for more details)
- numeric vital signs for all the measurements monitored
- any alarm conditions active when the event episode was triggered
- any annotations connected with the event.

You can navigate through the event database to view events retrospectively, and you can document events on a recording or report marked with the patient name, bed label, and the data and time.

Levels of Event Surveillance

The appearance of the Events windows and menus and the settings you can select for events depends on the event surveillance option purchased for your monitor: basic event surveillance, advanced event surveillance, or neonatal event review (NER). This table lists the differences between the options.

To determine which level of event surveillance your monitor has, select **Main Setup** then **Event Surveill.** followed by **Setup Events** and select the trigger group to see the available event groups.

- if the only event group listed is **NER**, your monitor has the Neonatal Event Review option
- if there is one event group and it is not **NER**, your monitor has the Basic Event Surveillance option
- if you see six event groups, your monitor has the Advanced Event Surveillance option.

Event Functionality	Basic Event Surveillance Option C06	Advanced Event Surveillance Option C07	Neonatal Event Review (NER) Option C04
Event groups	1	6 (one group can be configured to NER)	NER
Measurements per group	3	4	3 (plus 1 for episode recording)
Triggers per measurement	1	2	1
Trigger types	Simple ("at least one")	Combined ("at least two")	Simple ("at least one")

Event Functionality	Basic Event Surveillance Option C06	Advanced Event Surveillance Option C07	Neonatal Event Review (NER) Option C04
Annotation	no	yes	yes
Types of event episode	Average trend Snapshot events	Average trend High resolution trend Snapshot events	High Resolution Trend
Event views	Graphic Event Review window, Graphic Event Episode window	Summary view, graphic and tabular Event Review window, graphic and tabular Event Episode window	Graphic and tabular Event Review window, graphic and tabular Event Episode window
Database capability	25 events for 24 hours	25 events for 24 hours 25 events for 8 hours 50 events for 8 hours 50 events for 24 hours	25 events for 24 hours 25 events for 8 hours 50 events for 8 hours 50 events for 24 hours
Event Notification	no	yes	no

Event Groups

The event group

- monitors the patient's signals to detect event triggers
- defines which waveforms are recorded in the event data.

In basic event surveillance only one event group can be active at a time, with Advanced Event Surveillance all six groups can be active simultaneously. Active event groups monitor for event triggers.

Event groups are defined in Configuration Mode. In monitoring mode the groups can be adapted to current conditions, for example episode types and threshold levels can be changed.

Event Episodes

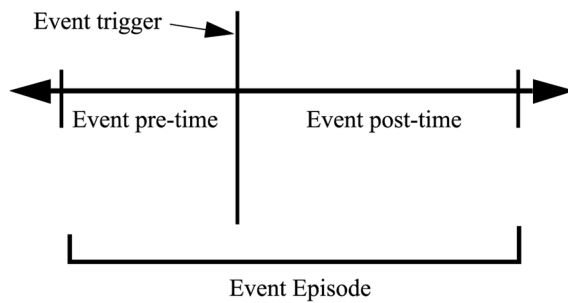

When an event occurs, information for a predefined duration is stored. This is the event episode. It includes information from a defined period before the trigger, called the event pre-time. The episode time after the event is called the event post-time. If a further event occurs during the event post-time it changes a single event to a combined event (combi-event).

Manually-triggered event episodes document patient information from the time leading up to the event trigger; they do not have a post-time.



The episode type defines the level of detail captured in an event episode. The higher the data resolution, the shorter the period that the monitor can store in its memory. High-resolution data is

suiting for neonatal applications, where the clinical situation may change very quickly. In adult monitoring, where the patient's status typically changes more gradually, a longer trend may be more informative.

Event Episode Types	Pre-time	Post-time
Average trend 20 minutes, five samples per minute	2 minutes	18 minutes
	4 minutes	16 minutes
	6 minutes	14 minutes
	8 minutes	12 minutes
	10 minutes	10 minutes
	12 minutes	8 minutes
	14 minutes	6 minutes
	16 minutes	4 minutes
HiResTrend Four minutes, four samples per second. Neonatal Event Review (NER) is a type of HiResTrend	18 minutes	2 minutes
	1 minute	3 minutes
	2 minutes	2 minutes
Realtime Wave Snapshot 15 seconds	3 minutes	1 minute
	5 seconds	10 seconds
	10 seconds	5 seconds

Events Pop-Up Keys

Depending on the events view you choose, a selection of the events pop-up keys let you navigate through the stored events and carry out events-related tasks.

Pop-Up Keys	Selecting this pop-up key lets you....
Event Setup	open the Event Setup menu.
Show Episode	open the Event Episode window to review the selected event in detail.
Show Review	open the Event Review window.
Review Group	choose a different event group for reviewing in the Event Review window (Advanced Event Surveillance only).
Show Summary	open the Event Summary window.
Manual Event	start a manually-triggered event capture.
Start CAR Stop CAR	open the Start CAR window to start a Car seat Assessment Record (CAR) period or stop a currently running CAR.
CAR Histogram	open the window showing the CAR SpO ₂ histogram
	move the cursor left or right to the next event to navigate through the events database. Placing the cursor over an event highlights it and shows the event values for the selected event.
	jump to the first or last event in the event database.

Pop-Up Keys			Selecting this pop-up key lets you....
Vitals View	Graphic View		toggle between a tabular and graphic version of the Event Episode window currently viewed.
Table Review	Graphic Review	CAR Review	toggle between a tabular and graphic version of the Event Review window currently viewed.
Delete Event			delete the currently-selected event from the database. The monitor asks you to confirm this deletion. You cannot retrieve deleted events.
Select Annotatn			access the list of available annotations to add a nursing note for the current event episode (Advanced Event Surveillance only).
Print/ Record			access the printing and recording pop-up keys to document events.

Event Triggers

You can trigger event capture manually, for example, if you want to record a patient's condition before a procedure. You can also set events to trigger automatically, when the patient's values cross a predefined threshold value, or when a particular measurement or procedure is carried out.

If more than one trigger is available for the measurements in the active event group, the trigger condition may be **At least one Param.**, **At least two Param.**, **At least three Par.**, or **All four Parameter**. If the trigger is **At least one Param.** (this is short for "at least one measurement parameter"), the monitor starts an event capture if a trigger occurs in any of this event group's measurements. If the trigger is **At least three Par.**, the monitor captures events when three or more trigger thresholds from this event group's measurements are violated. With **Enhanced Condition** you can not only select a minimum number of triggers to trigger an event but define which specific measurement triggers these must be. For example, **At least two Param.** will cause an event to be captured if a trigger occurs in any two of this event group's measurements - with **Enhanced Condition** you can select that only when triggers are in HR and SpO₂ an event will be captured.

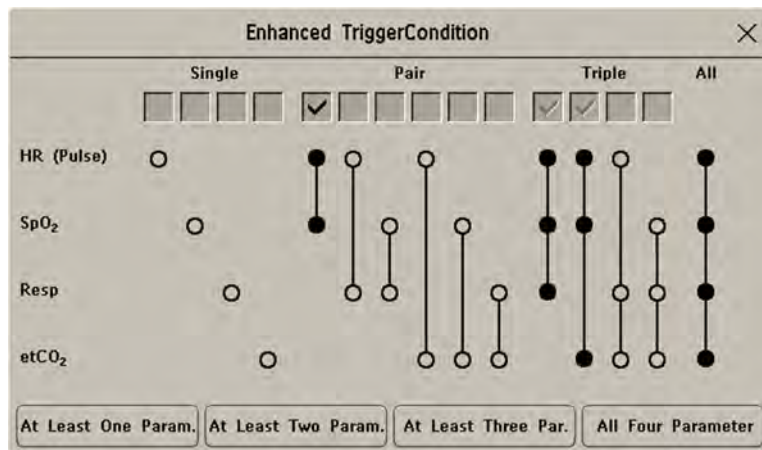

The trigger condition for event groups is set in the monitor's Configuration Mode.

If You Use Alarm Limits As Event Triggers

The event capture is triggered automatically when your patient's values violate set alarm limits, or when a specified alarm condition, such as apnea, occurs. No events of this kind are triggered if alarms are switched off. Changing alarm limits changes the event trigger definitions.

The asterisk symbols beside the trigger tell you about the alarm triggers:

*** indicates a high priority (red) alarm

** indicates a lower priority (yellow) alarm. This category includes short yellow arrhythmia alarms, which may be configured to be shown as one star alarms (*) on your monitor.

Triggers without asterisk symbols are user-defined triggers.

If You Set User-defined Threshold Triggers

You can define event triggers that are independent of alarm limits. You must set a threshold value and a threshold time for the trigger. If you set the trigger threshold time to 12 seconds, the monitor triggers an event if the threshold is violated for more than 12 seconds.

If You Set "On Measurement" Triggers

You can set aperiodic measurements (such as NBP) or procedures (such as Cardiac Output) to trigger an event whenever they start.

If You Set User-defined Deviation Triggers

You can define event triggers that are independent of specific limits and based instead on deviations from the current values. You must set a deviation and a period of time in which the deviation occurs. There are three types of deviation available: **ANY Deviation**, **UP Deviation** where only changes in a positive direction are detected and **DOWN Deviation** where only changes in a negative direction are detected. The deviation can be defined either in relative terms as a percentage, for example 10%, or as an absolute value, such as 10 bpm.

Event Retriggering

If a condition that triggered an event persists and the values remain beyond the trigger threshold, a new event will not be triggered.

For a new event to be triggered by the same condition, the measured values for at least one of the triggers must cross back into the normal range and then recross the trigger threshold.

Event Notification

Advanced Event Surveillance Only You can be notified when an event is detected. For each event group you can define a type of notification depending on the severity of the event conditions. The notification can be a status message with a prompt tone or a standard *, **, or *** alarm notification. These event alarms are handled exactly like measurement alarms; they can be silenced and are also suspended when all alarms are suspended. You should only use alarm notification for events which are comparable in severity to standard measurement alarms to avoid potential confusion due to too many alarms. Notification in the form of an alarm is not available when the trigger condition is **At least one Param..** Selecting **None** switches event notification off.

Setting the type of notification, or switching notification off, is done in Configuration Mode.

Setting Triggers for NER and Basic Event Surveillance

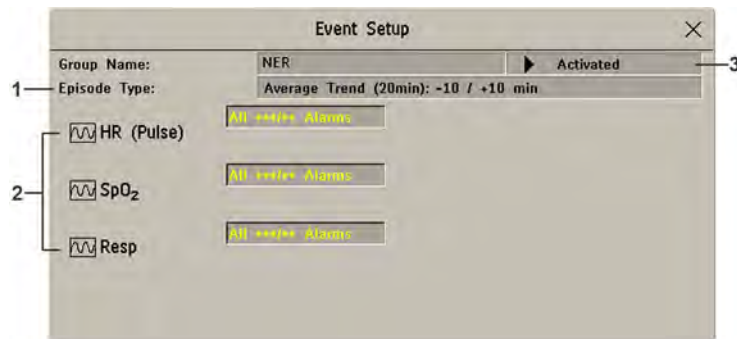

- 1 The **Episode Type** determines the pre and post time.
- 2 Measurements used as event triggers.
- 3 Current status: **Activated** or **Deactivated**

- 1 Select **Main Setup** then **Event Surveill.** followed by **Setup Events** to enter the **Event Setup** window.
- 2 Select the name of the current episode type to set the episode pre/post time.
- 3 Set the event trigger for each measurement. Select each trigger name and select, if available, either an alarm trigger, or a user-defined trigger from the pop-up trigger list. If you select a user-defined trigger, set the required threshold level and delay time.
- 4 Set the trigger status to **Activated** to start event triggering. If the status is **Deactivated** event surveillance is effectively switched off.
- 5 Select **Confirm** to confirm your changes.

Setting Triggers and Notification for Advanced Event Surveillance



- 1 **Notification Type** shows the currently configured notification
- 2 **Episode Type** determines the pre and post time
- 3 **Trigger Condition** shows the currently configured trigger requirements
- 4 Measurements used as event triggers
- 5 Current status: **Activated** or **Deactivated**

- 1 Select the group name to enter the setup window for that group.
- 2 Set the trigger status to **Activated**, to have this event group trigger events, or **Deactivated**.
- 3 Set the episode type.
Select the name of the current episode type and select an episode type from the pop-up list. The pre/post episode time for the selected episode type is displayed.

- 4 Set the trigger for each measurement. Select each trigger name and select either an alarm trigger or a user-defined trigger from the pop-up trigger list. If you select a user-defined trigger, set the required threshold level and delay time. If a deviation trigger is configured, set the deviation and duration.
- 5 Select **Confirm** to confirm your changes.

Triggering Events Manually

To manually trigger an event, select the SmartKey **Manual Event** and (for Advanced Event Surveillance) select the group in which the event will be triggered.

For manually-triggered events, patient information for the time leading up to the trigger moment is stored using the settings of the assigned event group.

Running a Car Seat Assessment Record

In the NER group you can run a Car Seat Assessment Record (CAR). This is a special period of event surveillance using the current setup of the NER group.

To start a CAR period:

- 1 Select the **Start CAR** pop-up key or SmartKey.
- 2 Select the required time period for the assessment.
- 3 Select **Confirm** to start the CAR.

If the NER group was not active it will be activated automatically.

During the CAR period an SpO₂ histogram is also generated with 1 second samples. For general information about the presentation of data in a histogram, see “Viewing Histogram Trends” on page 314. The CAR SpO₂ histogram is unique: it can only be accessed from the events function. It is generated from the beginning of the CAR period (contrary to the non-SpO₂ histograms which are generated from trended data retrospectively at the end of a time period). Settings are fixed for this histogram and cannot be changed when viewing it.

The Events Database

The maximum number of events that can be stored in the event database depends on the database configuration and the level of event surveillance used. The event database is set up in the monitor's Configuration Mode. Events are stored in the monitor's event database for the configured lifetime, either 8 hours or 24 hours. Deleted events cannot be retrieved. Events are automatically deleted when:

- their configured lifetime is over
- the storage capacity of the database is exceeded (storing a further event deletes the oldest event in the memory)
- a patient is discharged.

As the event database is cleared when you discharge a patient, you should ensure that you have documented any events you require for the patient records before you confirm the discharge.

Viewing Events

- To see a summary of all the events in every group in the event database, use the **Event Summary** window.
- To review all the events in a particular event group, use the **Event Review** window.
- To review individual event episodes in detail, use the **Event Episode** window.

To start viewing events, either:

- in the **Main Setup** menu, select **Event Surveill.** and then select the event view you require from the list, or
- select the **Event Surveill** SmartKey

and then select the event view you require from the list.

Event Summary and Event Counter



Vertical bars mark events in the **Event Summary** window. The timeline shows the position of the stored events in the event database. Selecting this view activates a cursor that lets you navigate across the timeline. Use the **Show Episode** pop-up key to select individual events for review in the **Event Episode** window. It also calls up the events pop-up keys.

The event counter counts the total number of events in the database. If more than one event group was set to trigger events within the event history, the event counter also counts the event group totals.

Counting Combi-Events





If one or more events occur during the same Episode Time, the monitor combines them and displays them as distinct events in one event episode, called a combi-event. The first event is the trigger event, and the others are follow-up events. For example, if an apnea event is followed 40 seconds later by a brady event, the brady event is not counted as a single event but as part of the apnea event.

Counting Neonatal Event Review (NER) Events

For neonatal events (NER, formerly "OxyCRG"), apnea events (A), bradycardia events (B), and combinations of these events are counted and classified by the event counter in the **Event Summary**. If they are associated with a Desaturation (D), this is also marked. Manual events (M) are counted separately. For example, A(D):2(1) indicates that two apnea events occurred and one of them was associated with a desaturation.

Event Summary Window

(Advanced Event Surveillance only). The **Event Summary** window shows the number of stored events in each event group and the total number of events in the database. Vertical bars mark events on a timeline showing the position of the stored events in the event database. The symbol next to the group name indicates the activation and notification status:

symbol	meaning
	group activated, notification set to ***alarm
	group activated, notification set to **alarm
	group activated, notification set to *alarm
	group activated, notification set to screen prompt
	group is activated, notification is switched off
no symbol	group not activated

Selecting the **Event Summary** window calls up the events pop-up keys.

Parts of the **Event Summary** window can also be embedded in Screens so that they are always visible, for example the **Total** row showing the total number of events with the bars on the timeline or the column showing all the groups with the activation and notification status.

Event Review Window

To enter the **Event Review** window, select the graphic event summary, if available, or select the events pop-up key **Show Review**.



When you open the **Event Review** window, it automatically shows the event group with the most recent event.

- To view other event groups, select the pop-up key **Review Group** and select the group from the list.

Event Episode Window

To enter the **Event Episode** window, select the pop-up key **Show Episode**.

Depending on the event group settings, the **Event Episode** window shows either 20 minutes of average trend event information, four minutes of high-resolution event information, or 15 seconds of realtime wave information.

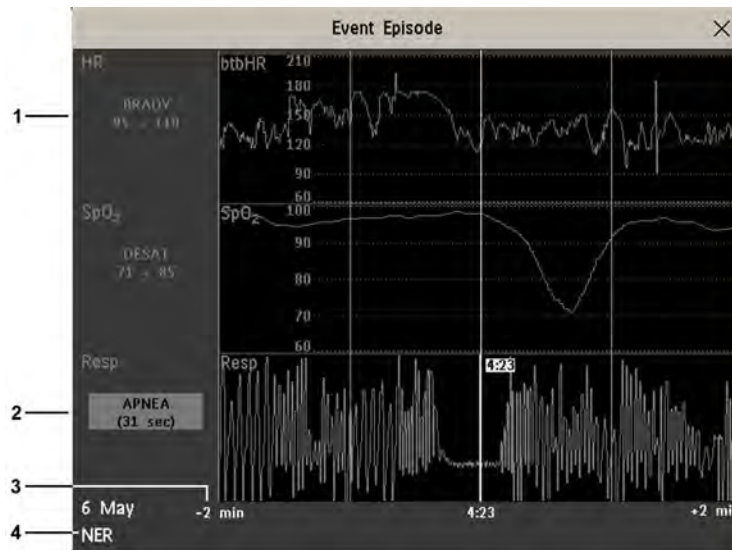

- 1 Follow-on event values
- 2 Trigger event values, highlighted
- 3 Timeline, showing episode Pre/Post-time
- 4 Active event group

The event values to the left of the measurement channels show the trigger threshold set and the maximum amount by which this limit was exceeded. In this example, Desat 71 < 85 tells you that 71 was the lowest SpO₂ value measured during the event time and that the Desat trigger threshold was set to 85 when the event was triggered. If the event was manually triggered, the event value boxes display "manual".

Annotating Events

- To annotate an event, in the **Event Episode** window, select the pop-up key **Select Annotatn.**
- Select the required annotation from the pop-up list of available annotations for the currently active event group.

Up to 20 annotations can be configured to let you add commonly-used clinical notes to event episodes for documentation purposes. To see the complete list of available annotations, in the **Event Setup** menu, select **Event Annotation**.

Documenting Events

You can print a report or make a recording of the events history stored in the database or of individual event episodes or a Car Seat Assessment Record.

Documenting Event Review

- 1 In the **Event Review** window, select the pop-up key **Print/ Record**. This calls up the event documentation pop-up keys.
- 2 For a graphic Event Review recording, select the **Record Graphic** pop-up key.
For a tabular Event Review recording, select the **Record Tabular** pop-up key.
For a CAR review report, select the **Print CAR** pop-up key
To print an Event Report, select the **Print Review** pop-up key.

Documenting an Event Episode

- 1 In the **Event Episode** window, select the pop-up key **Print/ Record**. This calls up the event documentation pop-up keys.
- 2 To make an Event Episode recording, select the **Record** pop-up key.
To print an Event Episode, select the **Print Episode** pop-up key.

Event Recordings

Event recordings can be sent to a locally-connected M1116B/C recorder module.

Event Review Recordings

Each event review recording strip begins with a summary of the events stored in the event database.

Recording strip annotation is explained in the Recording chapter.

6	90MIN	Green, Sarah	37549201
5	23 Jan 02 10:43	ICU 37	
4	Standard	Combi:0	Single: 2 Manual: 1 (Total: 3)
	Neuro:	Combi:0	Single: 0 Manual: 2 (Total: 2)
	Hemo:	Combi:0	Single: 0 Manual:2 (Total: 2)
	Ventil:	Combi:0	Single:1 Manual:1 (Total: 2)
	Arrhy/ST:	Combi:0	Single: 0 Manual:1 (Total: 1)
	NER	A(D):0(0) B(D):2(1) AB(D):1(1) D:0 M:2 (Total:5)	
3	All	Combi: 0	Single: 5 Manual: 9 (Total: 15)
	Groups:		
		2	1

- 1 Event total per event group
- 2 Event types
- 3 Total events in database
- 4 Event groups
- 5 Recording strip code
- 6 Patient information and medical record no.

In graphic event review recordings, events are represented by bars, and each event group is printed on a separate channel.

The timeline reflects the period stored in the database, either 24 hours (divided into 4 hour sections) or 8 hours (divided into one-hour sections).

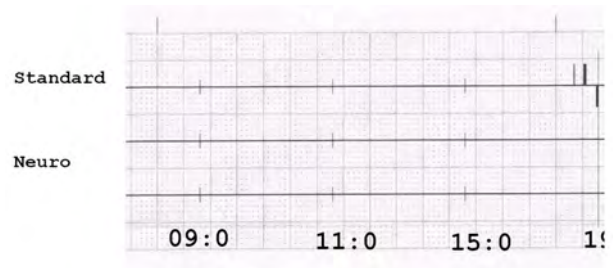

#	Time	Group	Parameter 1	Parameter 2
1	23 Jan 02 07:56	Neuro	Resp	BIS LOW 51<60
2	23 Jan 02 07:59	Standard	HR(Pulse) TACHY 201>180	ST-II
3	23 Jan 02 08:02	NeuroResp	HIGH 76>60	BIS
4	23 Jan 02 08:12	Standard	HR(Pulse)	ST-II Manual
5	23 Jan 02 08:32	Standard	HR(Pulse)	ST-II
...				

In tabular event review recordings, the events stored in the event database are shown in chronological order, with a number and time-stamp.

The measurements in the event group are shown in the next columns, marked "Parameter 1, Parameter 2...", along with the event values measured at the time of the event. For each event, the trigger values are shown.

This section of the recording is A4 or letter size, so that it fits in a patient file.

Event Episode Recordings

Event episode recordings are divided into four sections.

The first section shows the patient information and the event group of the episode with the event values for the group measurements. The trigger symbol marks the event trigger.

91MIN	Green, Sarah
37549201	
23 Jan 02 10:43	NER
Standard:HR(Pulse)	
	TACHY 130>120
	SpO2
	Resp HIGH 80>75

The second section (2 below) shows the waveforms recorded during the episode. The trigger moment is marked with a triangle and divides the episode into the pre/post time. Any calibration marks and grid marks on the screen are automatically printed on the recording.

If there are four measurements in the event group being recorded, two waveforms will be recorded in two separate waveforms segments.

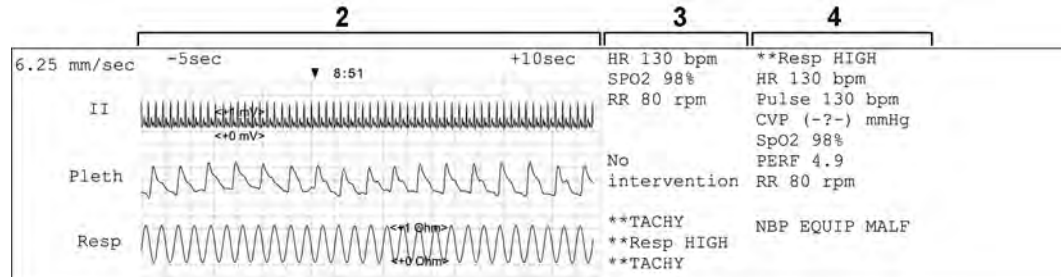

The third section (3 above) shows the most important vital signs information, including numerics, active alarms, and any annotations made on the event episode.

The fourth section (4 above) shows the numerics for all the currently monitored vital signs and any alarm conditions or INOPs active at the time the event was triggered.

Event Reports

Event reports can be printed on A4 and letter size paper on a printer connected locally or centrally to your monitor.

Event Review Reports

The event review report documents all the events stored in the event database for a selected group.

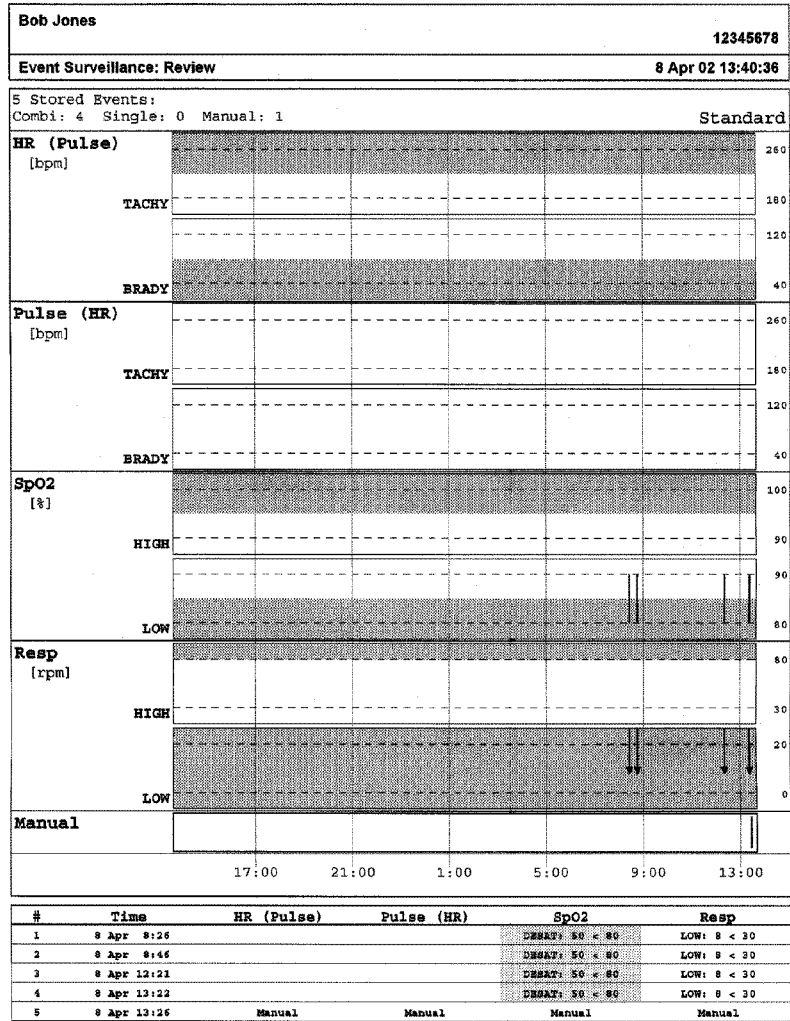

Event Episode Reports

The event episode report documents the patient information from the currently-selected event. See “Event Recordings” on page 343 for an explanation of the report elements.

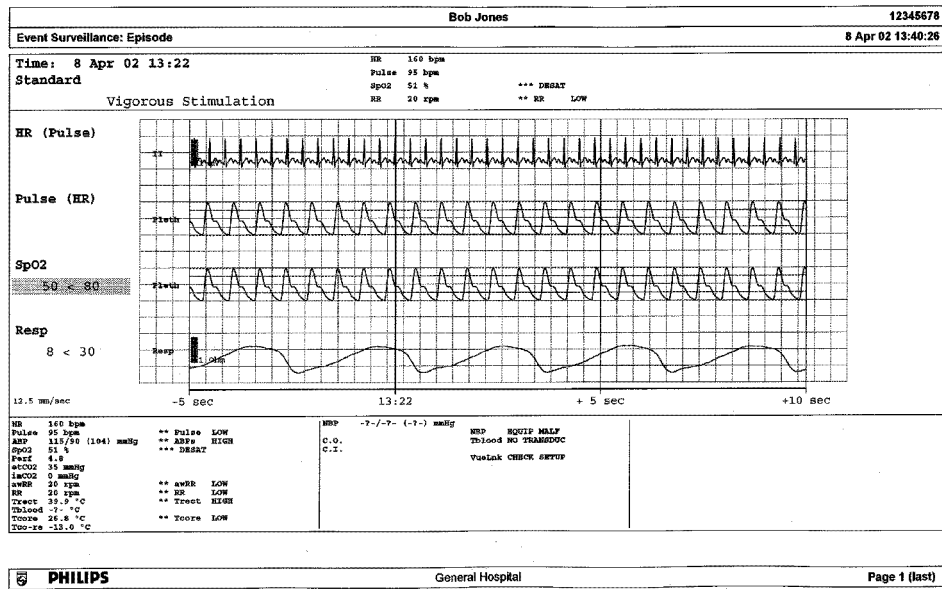

Event Summary Reports

(Advanced Event Surveillance only). The event summary report shows a graphical view and a tabular view of all events in the database for all groups.

Bed13		Event Surveillance: Episode				25 Oct 04 18:41:18
Standard						
Combi: 0 Single: 1 Manual: 0 (Total: 1) (?)						
Neuro						
Combi: 0 Single: 0 Manual: 0 (Total: 0)						
Hemo						
Combi: 0 Single: 1 Manual: 1 (Total: 2) (?)						
Ventil.						
Combi: 0 Single: 5 Manual: 0 (Total: 5) (?)						
Arby/ST						
Combi: 0 Single: 0 Manual: 0 (Total: 0)						
NER						
A(D): 0(0) B(D): 0(0) AB(D): 0(0) D: 3 M: 0 (Total: 3) (?)						
All Groups						
Combi: 0 Single: 10 Manual: 1 (Total: 11) (?)						
#	Time	Group	Parameter 1	Parameter 2	Parameter 3	Parameter 4
1	25 Oct 17:46	Ventil.		SpO2: LOW: 76 < 80		
2	25 Oct 17:46	Hemo	HR (Pulse): Manual	SpO2: Manual	ABP: Manual	CVP: Manual
3	25 Oct 17:54	Ventil.		SpO2: LOW: 74 < 80		
4	25 Oct 17:54	Standard		SpO2: LOW: 74 < 80		
5	25 Oct 17:54	Hemo		SpO2: LOW: 74 < 80		
6	25 Oct 17:54	NER		SpO2: DESAT: 74 < 80		
7	25 Oct 17:56	Ventil.		SpO2: DESAT: 74 < 80		
8	25 Oct 17:58	NER		SpO2: DESAT: 74 < 80		
9	25 Oct 18:00	Ventil.		SpO2: LOW: 74 < 80		
10	(25 Oct 18:37)	Standard		SpO2: DESAT: 74 < 80		
11	(25 Oct 18:37)	Hemo		SpO2: DESAT: 74 < 80		
12	25 Oct 18:37	Ventil.		SpO2: DESAT: 74 < 80		
13	25 Oct 18:37	NER		SpO2: DESAT: 74 < 80		
14	(25 Oct 18:40)	Ventil.		SpO2: LOW: 74 < 80		
15	(25 Oct 18:40)	NER		SpO2: DESAT: 74 < 80		

ProtocolWatch

ProtocolWatch (PW) is a clinical decision support tool. It allows you to run a clinical protocol which can monitor developments in the patient's condition, taking into account:

- measured values from the monitor
- values manually entered by you (for example manual temperature measurements, lab values)
- your assessment of patient status

ProtocolWatch notifies you when certain conditions or combinations of conditions occur and it documents developments in a log which can be printed.

SSC Sepsis Protocol

The SSC (Surviving Sepsis Campaign) Sepsis Protocol is a protocol implemented for the ProtocolWatch application. The SSC Sepsis Protocol is for use in screening for severe sepsis and monitoring of its treatment. It is a computerized implementation of the January 2008 Surviving Sepsis Campaign Guidelines for Management of Severe Sepsis and Septic Shock [Dellinger RP, Levy MM, Carlet JM et al: Surviving Sepsis Campaign: International guidelines for management of severe sepsis and septic shock: 2008 (published correction appears in *Crit Care Med*; 36:1394-1396). *Crit Care Med* 2008 36:296-327.], including the Amendment from October 2011. Philips does not make any claims about their effectiveness to reduce the morbidity or mortality associated with severe sepsis.

The SSC Sepsis Protocol assists you in recognizing the early signs and symptoms of sepsis by comparing the state of your patient to the defined criteria and then guides you through the recommended treatment protocol. Use of the SSC Sepsis Protocol requires thorough knowledge of the complete SSC Guidelines for Management of Severe Sepsis and Septic Shock. Due to space limitations on the screen, the recommendations cannot always be reproduced in the full detail available in the printed and on-line guidelines. The SSC Sepsis Protocol is not a diagnostic or therapeutic tool and is not intended to replace the competent judgment of a clinician.

The SSC Sepsis Protocol consists of three separate consecutive phases:

Severe Sepsis Screening - measurement values and patient status are compared to the Severe Sepsis Screening criteria. When these criteria have been met, the clinician confirms the presence of infection and sepsis-related organ dysfunction and can authorize entering the Sepsis Resuscitation Bundle.

Sepsis Resuscitation Bundle - the recommendations for sepsis resuscitation are listed and can be checked off as they are implemented. After achievement of all the sepsis resuscitation goals, or at the latest after 6 hours, the Sepsis Resuscitation Bundle is completed and the Sepsis Management Bundle begins.

Sepsis Management Bundle - the recommendations to maintain patient status are listed and can be checked off as they are implemented. The Sepsis Management Bundle ends when 24 hours have passed since the Sepsis Resuscitation Bundle began.

The SSC Sepsis protocol may have been configured, to customize it for the specific treatment measures used in your facility. This can include changes to limits for measured or manually entered values, changes to the Severe Sepsis Screening criteria, and changes to the recommendations in the Sepsis Resuscitation Bundle and the Sepsis Management Bundle. If configuration changes have been made, your screens may not exactly match the screens shown here.

Depending on the option your monitor has, it may be that only the Severe Sepsis Screening phase is implemented. If, at the end of this phase sepsis has been confirmed, and the patient is transferred for treatment in the resuscitation and management phases, you can transfer the current state, the settings and the log from the SSC Sepsis Protocol in the MMS to another monitor with the full version of the SSC Sepsis Protocol. The transfer of data and settings must be enabled in Configuration mode.

WARNING

Always consider the specific clinical context for your patient, before following SSC Sepsis Protocol treatment recommendations.

The SSC Sepsis Protocol and this description are based on the SSC Guidelines for Management of Severe Sepsis and Septic Shock from January 2008 (including the Amendment from October 2011) and the SSC Bundle definitions from January 2005. To check the version of the Guidelines and Bundle definitions on the monitor,

- Select **Main Setup** then **Revision** then **ProtocolWatch** followed by **SSC Sepsis**

Orientation On The Screen

At the top of each window there is an orientation line showing the phases available on your monitor, with the currently active phase highlighted.

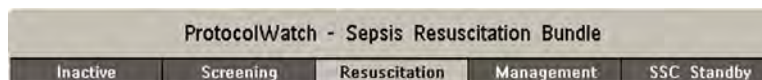

You can also place the ProtocolWatch symbol, together with the currently active phase, on the main screen, in one of the numeric positions. This allows you to see at a glance which phase is currently active, even when no SSC Sepsis Protocol window is currently displayed.

If you need to enter data or perform an action in an SSC Sepsis Protocol window, the symbol will turn into a SmartKey.

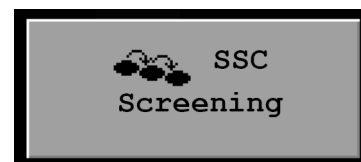

Transferring Patients and Moving Manually Between Phases

If a patient has already been diagnosed as having severe sepsis before connecting them to the monitor, you can select **Main Setup** then **ProtocolWatch** followed by **Manual Transition** to go directly to the Sepsis Resuscitation Bundle to monitor treatment. Direct entry to the Sepsis Management Bundle is also possible using the **Manual Transition** function and the time into the selected bundle can be set.

If a patient has been screened on arrival, for example in the emergency department, then transferred to Intensive Care when Sepsis is confirmed, the current state, the settings and the log from the SSC Sepsis Protocol will be transferred with the MMS to the new monitor. Should it be necessary, you can select the phase at the new monitor manually with **Main Setup** then **ProtocolWatch** followed by **Manual Transition**. The transfer of data and settings must be enabled in Configuration mode.

CAUTION

It is not possible to transfer SSC Sepsis Protocol data from a monitor with release F.0 software to another monitor with release G.0 software or above, and vice versa.

Suspending the Protocol for 24 Hours

To suspend the protocol for 24 hours:

- 1 Select **Main Setup** then **ProtocolWatch** followed by **Suspend for 24 hours**.
- 2 Select **Confirm**.

The protocol will resume activity after 24 hours with Severe Sepsis Screening.

Severe Sepsis Screening

As soon as an adult patient is connected to the monitor, and heart rate or pulse is being measured, the protocol begins to observe heart rate, temperature and respiration rate values in the background. If temperature or respiration rate is not being measured continuously, a pop-up window appears at 4-hour intervals to ask for manually measured values. These values are all compared to the screening criteria: HR above 90, Temp above 38.3°C (100.9°F) or below 36.0°C (96.8°F), RR above 20.

If any one of the values fulfills the screening criteria, the first **Severe Sepsis Screening** window appears.

The measured value which has fulfilled the criteria is shown highlighted. There are check boxes for the infection signs and symptoms listed,

- if the monitor has measured values which meet the screening criteria, and
- for all signs and symptoms which cannot be measured by the monitor.

Check the box if you can confirm that this sign or symptom is **present** and **new**. If the patient is mechanically ventilated, the **Mechanically ventilated** box must be checked. If you have manually measured temperature or respiration rate, you can enter the values using the **Enter RR** and **Enter Temp** keys.

Select **Confirm** when the check boxes reflect the current patient status.

Select **Remind 15 min** if you want to delay filling out this screen. (When you enter the screen manually this key will be a **Cancel** key, as no action is required in this case.)

Changing Conditions

The window reappears if:

- a previously fulfilled criteria is again fulfilled
- a new HR or RR criteria is fulfilled,
- the HR or RR value which previously fulfilled the criteria now triggers a **** RR High, ** HR High** alarm or a *****Tachy xxx > yyy** alarm,
- after 8 hours (configurable to 12 hours) if at least one infection sign is still present.

Two Or More Infection Signs Or Symptoms Confirmed

If you have confirmed two or more infection signs in the first Severe Sepsis Screening window, a new pop-up window appears asking **Is the patient history suggestive of a new infection?**

If you select **Yes**, the next screen appears requesting a lactate measurement.

If you select **No**, the screening phase continues and the first Severe Sepsis Screening window reappears in the situations described in “Changing Conditions” above.

Lactate Measurement

To enter the Lactate value, select the **Enter Lact** key. If the value entered is > 4 mmol/l the check box is automatically checked.

Select **Confirm** when a value has been entered. What follows depends on the Lactate value:

- If **Lactate is > 4 mmol/l**: the value meets the criteria for severe sepsis and a window appears recommending authorized clinician review before entering the Sepsis Resuscitation Bundle.
- If **Lactate is ≤ 4 mmol/l**: a further window appears requiring your input to determine on the basis of blood pressure values whether the patient meets the criteria for severe sepsis.

Hypotension Evaluation

If the Lactate value was not above 4 mmol/l, the next window asks whether the patient has persistent hypotension.

The protocol defines Hypotension as:

- SBP < 90 mmHg (12.0kPa), or
- MAP < 70 mmHg (9.3kPa), or
- SBP decrease > 40 mmHg (5.0kPa) below baseline.

You can see this definition in the window by selecting **Show Details**.

If the patient has persistent hypotension as defined, select **Yes**. This acknowledges that the patient meets the criteria for severe sepsis and a final window appears recommending authorized clinician review before entering the Sepsis Resuscitation Bundle.

If the patient does not have persistent hypotension, select **No**. After an hour a screen appears asking **Is the previously acknowledged infection still present?**

If you select **Yes**, the window for the Lactate measurement will reappear. If you select **No**, screening continues - comparing heart rate, temperature and respiration rate values against the screening criteria.

Authorized Clinician Review

To review the protocol, select **Protocol Log**. You can also print out the log to document the screening phase.

Select **Confirm** to complete the screening phase and, if you have the appropriate monitor option, continue to the Sepsis Resuscitation Bundle phase.

Sepsis Resuscitation Bundle

The treatment recommendations from the Sepsis Resuscitation Bundle are presented and the implementation of the recommendations is monitored.

When the Sepsis Resuscitation Bundle phase begins, the **ProtocolWatch** Screen automatically appears on the monitor (if configured and available on the monitor).

The lower area of the screen contains:

- a reminder list of the treatment recommendations - recommendations which have been fulfilled are shown in gray, overdue recommendations are shown in orange
- a timer showing the time already passed in this phase
- three horizon trends for MAP, CVP and ScvO₂ or SvO₂, if these measured values are available
- a list of the latest manually entered values - if you select this list you will open the **Manual Entry Log** window where the last 24 manually entered values are shown for reference

If ScvO₂ or SvO₂ and CVP are not being continuously measured, a pop-up window appears at hourly intervals to ask for a manually measured value.

Monitoring the Sepsis Resuscitation Bundle Recommendations

When you select the lower area of the **ProtocolWatch** Screen, the **Sepsis Resuscitation Bundle** window appears. If you do not have the **ProtocolWatch** Screen displayed, the **Sepsis Resuscitation Bundle** window appears automatically once an hour.

Select the **Enter Lact** key to enter a lactate value. When you have entered a value, or if a lactate value had previously been entered, the box is checked.

Check the **Take Blood Cultures** box when you have taken blood cultures.

Check the **Administer Intravenous Antibiotics** box when you have started broad-spectrum antibiotic therapy.

The remaining three recommendations are automatically compared to the Sepsis Resuscitation Bundle criteria, if the measurements are available on the monitor. A box is checked when the corresponding recommendation has been fulfilled.

Depending on your configuration, continuously measured CVP values may be disregarded if they exceed a set limit. Whether this is so, and which limit is applied, is set in the monitor's Configuration mode.

If you have manually measured ScvO₂ or CVP, you can enter the values using the **Enter ScvO₂** and **Enter CVP** keys. The box is checked automatically if the value fulfills the recommendation.

The boxes for MAP, ScvO₂/SvO₂ and CVP can also be checked manually (for cases where the monitor does not measure them) but only when the timer has reached 4 hours to ensure that these values are achieved and maintained mid-term. Check these boxes if the recommendation has been fulfilled.

To see more details about the recommendations, select the **Show Details** key.

Select **Confirm** when the check boxes reflect the current treatment status.

Checking The Sepsis Resuscitation Bundle Window

During the Sepsis Resuscitation Bundle you can open the **Sepsis Resuscitation Bundle** window at any time to check the status or to make entries. The recommendations are shown as follows:

- Recommendations which are not yet fulfilled are shown in black. They also appear in the list on the lower area of the **ProtocolWatch** Screen.
- Recommendations which are overdue are shown in orange.
- Recommendations which have been fulfilled and confirmed are shown in gray. They no longer appear in the list on the lower area of the **ProtocolWatch** Screen.

Previewing the Sepsis Management Bundle

At any time during the Sepsis Resuscitation Bundle you can preview the Management Bundle in order to see which recommendations will follow there.

- Select the **Preview Managmnt** key.

Ending The Sepsis Resuscitation Bundle

When all recommendations have been fulfilled and confirmed, or when 6 hours have passed since the bundle started, the Sepsis Resuscitation Bundle is ended.

You are asked to confirm with the **Yes** key that the Sepsis Management Bundle should now be started. If you select **No**, the Sepsis Resuscitation Bundle is extended for 1 hour.

Sepsis Management Bundle

The stabilization recommendations from the Sepsis Management Bundle are presented and the implementation of the recommendations is monitored.

When the Sepsis Management Bundle phase begins, the **ProtocolWatch** Screen is automatically updated (if configured and available on the monitor). In the lower area of the Screen, the list of recommendations for the Sepsis Management Bundle replaces the list for the Sepsis Resuscitation Bundle. The timer shows the combined time for both phases.

Monitoring the Sepsis Management Bundle Recommendations

When you select the lower area of the **ProtocolWatch** Screen, the **Sepsis Management Bundle** window appears. If you do not have the **ProtocolWatch** Screen displayed, the **Sepsis Management Bundle** window appears automatically once every six hours.

The **Low Dose Steroids for septic shock per policy** recommendation may not appear if it has been configured not to do so for your hospital.

Check the **Low Dose Steroids administered** box when you have started steroid therapy or the **Low Dose Steroids contra-indicated** box if this treatment is contra-indicated for your patient.

The boxes for **Maintain Glucose <8.3mmol/l (150 mg/dl)** and **Maintain Insp. Plateau Pressure <=30cmH₂O** can only be checked when the timer has reached 20 hours to ensure that the stabilization of these values is achieved long-term. Check these boxes if the recommendation has been fulfilled.

Recommendations which have been fulfilled are shown in gray with the time fulfillment was entered.

To see more details about the recommendations, select the **Show Details** key.

Select **Confirm** when the check boxes reflect the current treatment status.

Ending The Sepsis Management Bundle

The Sepsis Management Bundle normally ends 24 hours after the Sepsis Resuscitation Bundle started, as documented by the bundle timer on the **ProtocolWatch** screen. You are asked to confirm with the **Yes** key that routine monitoring should now resume. By selecting **No** you can extend the Sepsis Management Bundle phase by an additional 6 hours.

After completion of the Sepsis Management Bundle a sepsis standby phase begins which allows time for further patient stabilization and recovery. During this phase Severe Sepsis Screening is suspended. The standby phase is by default 7 days but the length can be adjusted in Configuration Mode.

Viewing and Printing the Protocol Log

The Protocol Log stores all user interactions, alarms and phase transitions while the SSC Sepsis Protocol is running.

To view the Log select **Main Setup** then **ProtocolWatch** followed by **Protocol Log**

You can choose between three different views of the Protocol Log:

- **Summary View** - a short form which does not include when the windows were triggered
- **Full View** - a complete log of all user interactions, alarms and phase transitions
- **Phase View** - you can view log entries for one phase by selecting that phase on the orientation line

When the Log consists of several pages, you can move through the pages with the **Previous Page** and **Next Page** keys.

To start a Protocol Log printout, select **Print**.

The log is cleared whenever a patient is discharged.

Always Discharge Patients

It is essential that patients are discharged when monitoring ends. As a reminder, the monitor can be configured to display a pop-up window when the monitor has been switched off, in Standby mode, or not monitoring basic vitals for a certain time. The window asks whether a new patient is being monitored and offers a pop-up key to discharge the previous patient if this is the case. The window must be configured in Configuration Mode.

When the previous patient is discharged, this clears the protocol log, resets the timers and deletes manually entered measurement values.

Recording

There are two ways to record data using your monitor. If a paper-strip recorder is available, you can make paper recordings, selecting from a variety of recording types. If no paper-strip recorder is available, or if you want to record data in an electronic form, you can use electronic recording. See “Paper-Strip Recording” on page 357 and “Electronic Recording” on page 365 for further details

Paper-Strip Recording

MX500/550/600/700/800 The M1116B/C plug-in recorders record numerics for all active measurements and up to three waveforms. You can use them for local recording mounted in the monitor's FMS.

M1116B

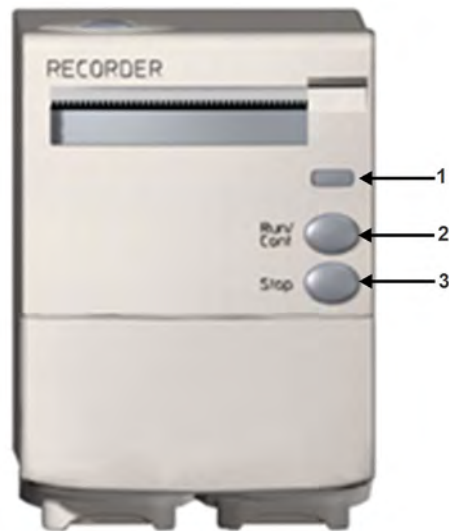

- 1 Continue LED - lights if a continuous recording is ongoing
- 2 RUN/CONT key - starts a delayed recording, extends the current recording or makes the current recording continuous
- 3 STOP key - stops the current recording

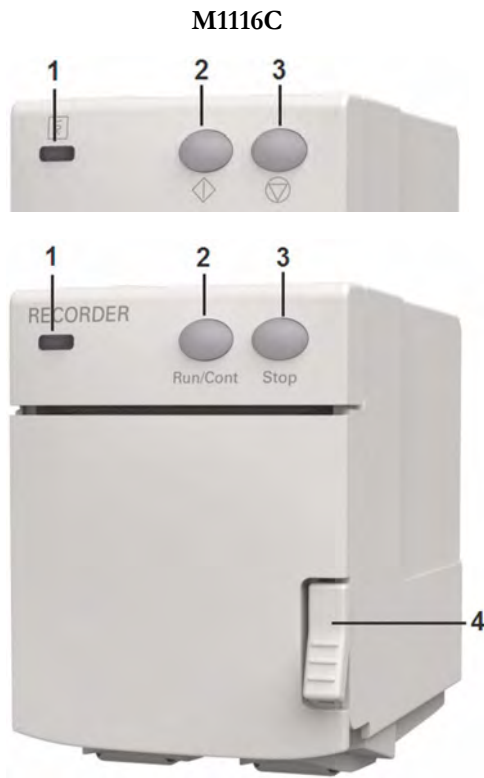

- 1 Continue LED (⏏) - lights if a continuous recording is ongoing.
- 2 Run/Cont key (⏏) - starts a delayed recording, extends the current recording or makes the recording continuous.
- 3 Stop key (⏏) - stops the current recording.
- 4 Door latch.

Integrated Recorder

MX400/450 The optional integrated recorder records numerics for all active measurements and up to three waveforms.



- 1 Open recorder latch

Central Recording

For central recording from the bedside, your monitor must be connected via a network to an Information Center. You can use either the M1116B 2-Channel Recorder or the standalone M3160A 4-Channel Recorder. Recordings made on the M3160A may look slightly different to those described here. See the documentation supplied with the Information Center for information on the 4-Channel Recorder.

Starting and Stopping Recordings

The recordings pop-up keys let you start and stop recordings. Select the **Recor- dings** SmartKey to call up the line of pop-up keys. Scroll right or left to see any pop-up keys not displayed.

The selection of pop-up keys available depends on the monitor you are using.

Delayed Recordng	Vital Signs
RT A Recordng	Alarm Limits
RT B Recordng	ST Segments
RT C Recordng	STE Segments
Select Waves	ECG QT
HiRes Recordng	Setup Recordng
All ECG Waves	Stop All Recordng

Quickstarting Recordings

To quickstart any type of recording using a pre-configured recordings template,

- Select the **Recor- dings** SmartKey and then select the pop-up key of the recording type you want to start.

Alternatively, you can

- Select the **Main Setup** SmartKey, select **Recordings**, then select the recording type.

To quickstart a delayed recording,

- Select the SmartKey **Delayed Record** to immediately start a delayed recording.

M1116B/C only You can also start a delayed recording by pressing the Run/Cont key on the recorder module.

Extending Recordings

Timed (non-continuous) recordings stop when their runtime is over. Continuous recordings continue until stopped manually or by an INOP condition.

- To extend an ongoing recording by its runtime, reselect its **Start** pop-up key once.
- To make an ongoing recording continuous, reselect its **Start** pop-up key twice within 5 seconds.

M1116B/C only You can also make an ongoing recording continuous by pressing the Run/Cont key on the recorder module.

Stopping Recordings

Recordings stop automatically when the preset runtime is over, when the recorder runs out of paper, when you open the recorder door or when the recorder has an INOP condition.

- To manually stop a recording, select the **Recording** SmartKey and then select the pop-up key **Stop All Recording**.

M1116B/C only You can also stop a recording by pressing the Stop key on the recorder module.

Recording Without a Template

To record without a pre-configured template, selecting the waves you require,

- Either:* Select the **Recording** SmartKey then select the pop-up key **Select Waves**.
Or: Select the SmartKey **Record Waves**.
- Use the pop-up keys to choose up to three measurement waves to be printed on the recording. If you want fewer than three waves on the recording, select the waves you want then select the **Continue** pop-up key.
- Select one of the recording speed pop-up keys to set the required recording speed.
- Select the **Start** pop-up key to start the recording.

Select Waves recordings use default values for any recorder settings not defined: runtime is continuous, overlapping is set to non-overlapping.

Overview of Recording Types

This table details settings for local recordings. For details on recordings made on the central recorder, see your Information Center Instructions for Use.

	Delayed	Alarm		Realtime (RT)	All ECG Waves	HiRes Trend	Procedure or Context
Type of recording	manual	automatic, triggered by defined alarm conditions		manual	manual	manual	manual, use the context window's pop-up keys to start
Recording Destination	local recorder and central	local recorder and central	printer	local recorder and central	local recorder only	local recorder only	local recorder only
Information recorded	from the start trigger minus the delay time	from the start trigger minus the delay time	n/a	from the start trigger	from the start trigger, in realtime	from the start trigger minus delay time	defined by the context
Number of waves	up to 3	up to 3	n/a	up to 3	all ECG waves currently monitored and available	up to 3 high-resolution trends (beat-to-beat) waves	up to 3 waves, or specific to the context, e.g. a wedge procedure
Speed	50, 25, 12.5, 6.25, 2.5 mm/sec	50, 25, 12.5, 6.25, 2.5 mm/sec	n/a	50, 25, 12.5, 6.25, 2.5 mm/sec	25 mm/sec	1, 2, 2.5, 3, 6 cm/min	defined by the context
Runtime	15, 20, 25, or 30 seconds	15, 20, 25, or 30 seconds	n/a	6, 8, 10, 15 seconds or continuously	4 seconds per wave	10 minutes, or continuously	defined by the context

	Delayed	Alarm		Realtime (RT)	All ECG Waves	HiRes Trend	Procedure or Context
Stops	automatically	automatically	n/a	automatically if limited, manually if continuous	automatically	automatically if limited, manually if continuous	defined by the context
Delay Time	10, 15 seconds	10, 15 seconds	n/a	none	none	6, 5, 4, 3, 2, 1 minutes	defined by the context
Overlap	up to 3 waves	up to 3 waves	n/a	up to 3 waves	none	up to 3 waves	defined by the context

n/a = not applicable

All ECG Waves Recordings

An **All ECG Waves** recording shows a 4 second recording of each lead with a calibration bar preceding each ECG lead. All available leads are recorded sequentially in the standardized lead order. The recording is realtime, that is, the information recorded is not simultaneous.

Creating and Changing Recordings Templates

To save you defining recording settings each time you start a recording, you can create templates for commonly-used types of recordings in the **Setup Recording** menu. You can create templates for one delayed recording, one alarm recording, three realtime recordings (two for MP20/30), and one high resolution recording. **All ECG Waves** recordings do not need to be configured, they always use the same format.

Changing recordings templates changes the settings that will be used each time a recording of this name is triggered.

- 1 Select the **Main Setup** permanent key to call up the **Main Setup** menu.
 - 2 Select **Recordings** to enter the **Setup Recording** menu.
 - 3 Select the name of the template you want to create or change. Each recording name is linked to a recording type, delayed, alarm, realtime, and hi-res trends. Recording names can be changed in the monitor's Configuration Mode.
 - 4 Design the template by selecting each menu item and entering the information for the template.
 - **Recorder:** choose which recorder the recording will print to (**Local**, **Central 2-Ch**, or **Central 4-Ch** recorder, or **Printer** (for realtime reports in alarm recording only)).
 - **Channel 1, Channel 2,** etc.: choose which waveform to record in each channel. If the wave assigned to a recording channel in a particular template is not available when a recording is triggered, the channel is left blank on the recording strip. The pop-up list of available (currently monitored) waves differs according to the recording type:
 - Realtime, delayed and alarm recordings: the list shows all the currently available waves.
 - High-resolution recordings: the list shows all the available high-resolution waves.
- In addition to the currently available waves, you can choose from several other settings which make an automatic allocation when the recording starts:
- **Alarm Par** will always record the measurement in alarm in the chosen recorder channel
 - **Primary Lead** will always record the current primary lead in the chosen recorder channel
 - **SecondaryLead** will always record the current secondary lead in the chosen recorder channel
 - **Any Agent** will always record the currently selected anesthetic agent.
- For high-resolution recordings only the **Any Agent** setting is available.

- **Overlap:** define whether the recorded waveforms will be printed overlapping or beside each other.
- **Speed:** choose the recording print speed.
- **Delay Time:** Delayed recordings start documenting on the recorder strip from a pre-set time before the recording is started. This interval is called the "Delay Time" and can be set as specified in "Overview of Recording Types" on page 360. This setting can only be changed in Configuration Mode.
- **Run Time:** see how long this type of recording is configured to run. This setting can only be changed in Configuration Mode. Continuous recordings run indefinitely.

Central Config: if available in the **General** menu, select this setting to use the recording settings made for the centrally-connected recorder.

Changing ECG Wave Gain

The **ECG Gain** setting in the **General Recording Setup** window defines how every recorded ECG wave, irrespective of template or recording type, will appear on the recorder strip. This does not affect the displayed ECG wave, or printed ECG reports. To change the ECG gain setting for recordings,

- 1 In the **Setup Recording** menu select **General**.
- 2 Select **ECG Gain**.
- 3 Select the required setting:
 - **Auto:** the wave recording will use the same scale as the ECG wave on the monitor screen
 - **5 mm/mV, 10 mm/mV, 20 mm/mV:** the wave recording will use a scale of 5, 10, or 20 millimeters per millivolt.

Recording Priorities

Manually-started recordings have priority over automatically-started recordings. If an automatically-triggered alarm recording is running, and a realtime or delayed recording is manually started, the alarm recording is stopped and the manually-requested recording is started.

More recent manually-started recordings have priority over older manually-started recordings. If a manually-started recording is running, and another manually-started recording is triggered, then the older recording is stopped and the more recent manually-started recording is started.

Alarm recordings are prioritized according to alarm priority. If an alarm recording triggered by a yellow alarm is running and a new alarm recording is triggered by a red alarm, the yellow alarm recording is stopped and the red alarm recording is started.

Recording Strip

The information printed on the recording strip includes the patient name and MRN, bed number, date and time of recording, recording speed, and (except when the information is printed above the waves) recording code. Active alarm and INOP messages as well as numerics for all currently monitored measurements are also printed.

Recording strip annotations are printed at the beginning of the recording strip, either before or above the waves depending on the configuration. The annotations are updated at regular intervals, every 15 minutes for recordings made at speeds lower than 6.25 mm/s, and every 60 seconds for recordings made at speeds greater or equal to 6.25 mm/s. When annotations are configured to appear above the wave, it may not be possible to print them all when the runtime of the recording is too short.

Recording Strip Code

The recording strip code printed in the first line of the initial annotation has up to seven characters, specifying recording type, operating mode, application area, patient category, and delay time, if applicable. It is only included when annotations are configured to appear before the waves.

	Code	Meaning
Recording type	90	Realtime
	8A	Delayed
	0B	Alarm
	91	Context (Procedures)
Operating mode	M	Monitoring
	D	Demo
	C	Configuration
	S	Service
Application area	I	ICU
	O	OR
	C	CCU
	N	NICU
Patient category	A	Adult
	P	Pediatric
	N	Neonatal

Recorded Waveforms

A selection of up to three waveforms is recorded, marked with wave labels and wave scale information. Wave scale information can be in the form of a calibration bar, like the 1 mV calibration bar for ECG, or calibration steps before the waveform starts.

Maintaining Recording Strips

Recording ink sometimes fades when covered with transparent tape. Avoid covering any part of a recording that is clinically relevant (annotation or waveforms) when taping a recording strip to a patient record or other patient documentation.

Reloading Paper

M1116B (MX500/550/600/700/800)



- 1 Use the latch on the right side of the recorder door to pull the door open.
- 2 Remove the empty core.
- 3 Insert a new roll so that it fits snugly into its housing and the paper end is feeding from the top. Recommended paper: 40477A and 40477B.
- 4 Pull out some paper and fold along the front edge at a 45° angle. This makes it easier to feed the paper under the roller as shown.
- 5 Feed the paper through and pull some paper out from the top of the roller.
- 6 Close the recorder door.
- 7 To test if paper is loaded correctly, start a recording. If no printing appears, paper may be loaded backwards. Try reloading the paper.

M1116C (MX500/550/600/700/800) and Integrated Recorder (MX400/450)

- 1 Press the latch on the right side of the recorder door to open the door.
- 2 Remove the empty core.
- 3 Insert a new roll and secure it in place on the paper holder. The paper feeds from the bottom of the roll and over the top of the recorder door.

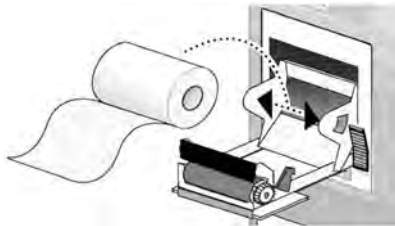

Recommended paper: M4816A and M4817A.

- 4 With at least one inch of paper extending beyond the edge of the door, swing the recorder door up and push it firmly closed.
- 5 To test if paper is loaded correctly, start a recording. If no printing appears, paper may be loaded backwards. Try reloading the paper.

CAUTION

When the recorder is disabled (for example, door open, or out of paper), any alarm recordings will be sent to the central station recorder, if there is one. If no recorder is available, alarm recordings may be lost during the time the recorder is disabled. The message **No alarm recording available** will be displayed. This message is not shown if **Printer** is configured as the alarm recording destination.

Recorder Status Messages

Recorder Status Messages	Explanation
For example: Local alarm recording running	The named recording is currently running.
No Central alarm recording available No local alarm recording available	No alarm recording can be made on the selected recorder. Try selecting another recorder. If a local recorder was selected, the monitor will try to reroute the recording to a central recorder. Recordings configured to a central recorder cannot be rerouted to a local recorder. Alarm recordings may be lost. Try configuring Printer as the alarm recording destination.
No alarm recording available	No recorder available. Alarm recordings will be lost. Try configuring Printer as the alarm recording destination.
Central Recorder out of paper Local Recorder out of paper	The named recorder is out of paper.
Central Recorder door open Local Recorder door open	The door of the specified recorder is open.
<Recorder Type> not supported	The M1116A recorder is not supported. Connect a M1116B/C plug-in recorder.

Electronic Recording

Electronic recording allows alarm-triggered reports to be captured electronically in the monitor database. They can then be printed when a printer is available. The printer can be locally connected at the USB interface, a central printer connected to the Information Center or the XDS Printing Service that is part of the IntelliVue XDS Application. With an XDS print server, the reports can be printed to a standard off-the-shelf printer and can also be stored as files (e.g. .jpg, .bmp or .pdf) on the associated PC.

Capturing Alarm Events

The monitor can be set up to automatically capture alarm events, triggered by selected alarms.

All settings must be made in Configuration mode.	The output device for alarm recordings is set to "printer". This automatically makes the alarm event documentation a realtime report.
	The target device for realtime reports is set to "database"
	The alarms to trigger the report are set up.
	The database is set to print automatically when a printer is available.

When one of the selected alarms occurs, the monitor automatically captures the alarm and creates a realtime report which is stored in the database.

As soon as the monitor is connected to a printer, or to a PC or network with the IntelliVue XDS Application software, it will automatically print the report, or send it to a patient-specific folder as an electronic file.

Alarm-Triggered Realtime Reports

Here is a sample of a realtime report triggered by an alarm event.

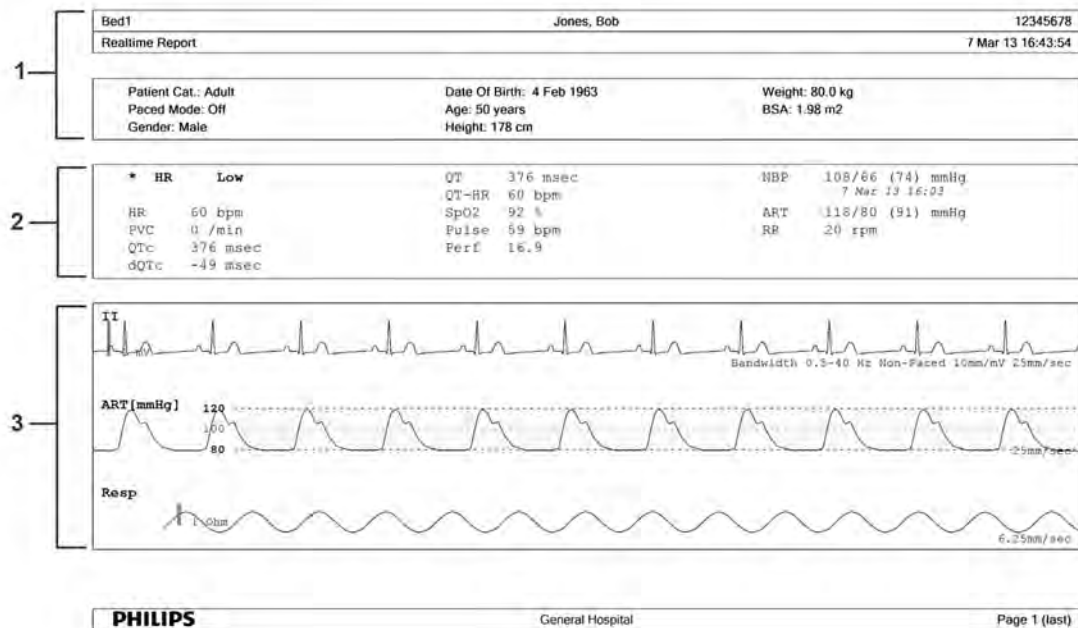

- 1 Patient demographic information, time stamp
- 2 Active Alarms and INOPs, followed by vital signs
- 3 Measurement waves section

The data in the report are from the period before the alarm triggered the report. The span of time covered by the wave data depends on the wave speed of the individual waves.

The time stamp on the report is the time the report was created and may not exactly correspond with the time the alarm was indicated on the monitor.

More Information About the Print Database

The reports captured in the database will remain there until they are printed, even after patient discharge. When they have been sent to the printer they will be automatically deleted from the database.

NOTE

The monitor cannot check for printer errors. If a report is sent to a printer but cannot be printed due to an error, it may be lost. Use an XDS print server set up to save the reports as electronic files, to ensure that no reports are lost.

The maximum number of reports that can be stored in the database varies depending on the database configuration and the size of the reports. When the database is full, no new reports can be stored. In this case, print or delete reports to make space available in the database.

Printing Patient Reports

Starting Report Printouts

Most patient reports can be printed by selecting **Main Setup** then **Reports** (or the **Print Reports** SmartKey) and then selecting the report name in the top half of the **Reports** menu. Report names are shown only for reports that have been correctly set up.

Data from the time of the print request is printed, even if the print job is delayed in the printer queue.

Your monitor can also be set up to automatically print all reports when a matching printer is available. To set this up

- 1 Select **Main Setup** then select **Reports**
- 2 Select **Auto Print Dbs.**
 - **Always** will print all reports when a matching printer is available.
 - **Host Only** will print the reports stored on the host monitor when a matching printer is available. Reports stored in the companion database (shown in gray on the **Reports Job List**) must be manually sent to the printer. See “Checking Report Status and Printing Manually” on page 375.
 - **Never** will print no reports automatically; all reports stored in the host or companion database must be manually sent to the printer. See “Checking Report Status and Printing Manually” on page 375.

Printout Location

Depending on availability, reports can be printed:

- on locally connected printers,
- on printers connected to the Information Center or the Application server,
- to an IntelliVue XDS Application print service,
- to an external PC-based print server with Philips server software,
- into the print database.

Print jobs stored in the database are automatically printed when a print device with a matching paper size becomes available.

Print jobs in the print database are **not deleted** after a patient discharge. A new patient can be admitted and their reports are saved in addition to the previous reports. Always admit your patient so that reports can be clearly assigned to a patient.

When an X2 is connected to a host monitor, reports requested or stored on the X2 can be printed via the host monitor. Reports requested on the X2 when connected to a host monitor will not show any patient alarms or INOPs. In order to see alarms, reports should be requested on the host monitor.

Starting the Different Types of Report

Report types	Report contents	How to start printing reports
Vital Signs Report	Depends on selected trend group, data resolution, and period.	In the Vital Signs window, select Print/ Record , then select Print .
Graphic Trends Report		In the Graphical Trends window, select Print .
Events Reports	Event Episode	In the Event Episode or Event Review window, select the pop-up key Print/ Record , then select Print Review or Print Episode .
	Graphic or tabular Event Review	
EEG Report	EEG Waves, numerics, CSAs, montage information and impedance values	In the Setup EEG menu, select Print Report .
ECG Reports	Depends on format selected.	Select the ECG Report A or ECG Report B SmartKeys, if configured, or the Print Reports SmartKey followed by ECG Report A or ECG Report B .
12-Lead Report	Captured ECG waves, measurement values, ST Map (optional) and analysis results from the Information Center (PHIC iX only)	In an active 12-Lead application window, select the Print Report pop-up key
ST Map Report	ST data in a transversal and/or horizontal multi-axis diagram,	In the ST Map (Current) or ST Map (Trend) window, select Print .
Cardiac Output Report	Trial curves and numerics	In the Cardiac Output (Right Heart) or Cardiac Output (Transpulmonary) window, select the pop-up key Print/ Record .
Wedge Report	Wedge numerics and reference wave	In the Wedge window, select the Print Wedge pop-up key.
Calculations Report	Hemodynamic, Oxygenation, or Ventilation Review	In the Calculations windows, select the Print/ Record pop-up key.
Drug Calculator Report	Titration Table	In the Titration Table window, select the Print Titr.Tbl pop-up key.
	Drip Table	In the Drip Table window, select the Print Drip Tbl pop-up key.
Alarm Limits Report	Graphic and numeric report of all current alarm limits	In the Alarm Limits window, select Print Limits .
Realtime Reports, including oxyCRG Reports	Patient data and numerics, and either: all displayed waves OR all measured waves OR all measured RT waves OR all measured HiRes waves, OR oxyCRG waves (RT waves: ECG Primary lead, Pleth, Resp; HiRes waves: btbHR, HiRes SpO ₂ , HiRes Resp)	Select the Realtime Report SmartKey, if configured.
Loops Report	Individual Loops diagram with timestamp, currently measured numerics	In the Loops window, select Print Loop .
Central Report A/B/C	These are reports configured at the Information Center. Monitors connected via the IntelliVue Instrument Telemetry wireless network can have these reports available.	In the Main Setup select Reports then Central Report A , Central Report B or Central Report C .

Stopping Reports Printouts

- To stop Reports printing, in the **Reports** menu, select
 - **Delete Report** to stop the current print job
 - **Delete All Repts** to cancel all queued report printouts
 - **Scheduled Rep.** to select **Off** and switch off scheduled reports.

Setting Up Reports

As the content of context-linked reports, such as Cardiac Output, Calculations, and Wedge, is defined by the content of the procedure window these reports do not need to be set up, however a target printer can be configured in the **Setup Reports** menu.

The content you define in the individual **Setup Reports** menus will be used in all reports of this type: for example, if you set a print speed of 50 mm/sec in the **ECG Reports** menu, every ECG report will be printed at this speed, irrespective of format.

ECG report layout and Auto Reports settings must be defined in Configuration Mode.

Setting Up ECG Reports

The settings you choose in the **ECG Reports** menu apply for all ECG-A and ECG-B reports printed. To set up ECG Reports,

- 1 Select **Main Setup, Reports**, then **ECG Reports**. Note the report layout configured for your monitor, either **Internat** or **Cabrera**. This setting is inactive ("grayed-out") in Monitoring Mode and can only be changed in Configuration Mode.
- 2 Select **ECG Gain** and set the required ECG gain to define how ECG waves will appear on the ECG report printouts.
- 3 Select **Speed** and select the report print speed.
- 4 Select **Annotation** and switch to **On** if the printed ECG wave should be annotated with beat labels. See the "ECG, Arrhythmia, ST and QT Monitoring" chapter for a list of beat labels. Pace pulse marks are automatically printed beside the wave for paced patients.

Setting Up Vital Signs and Graphic Trend Reports

The settings you choose in the **Vital Signs Report** and **Graphical Trend Report** menus apply for all Vital Signs and Graphic Trend reports printed.

To set up Vital Signs and Graphic Trend reports,

Select **Main Setup, Reports**, then **Vital Signs Rep.** or **Graph Trend Rep.**

- 1 Select **Trend Group** and select the group you want to print on the report. The groups available depend on your monitor's trend configuration.
- 2 Select **Period** and select the period of time for which trend data should be printed on the report. If **Automatic Period** is configured to **On**, all trend data for the current patient will be printed, irrespective which trend period is selected.
- 3 Select **Interval** (Vital Signs Reports only) and select the resolution of the trend data printed on the report.

Setting Up Auto Reports

Auto Reports print automatically when a specified trigger occurs. There are two types of Auto Reports: Scheduled Reports, which print at predefined intervals, and End Case Reports, which print when a patient is discharged using the End Case function. An Auto Report can be both a Scheduled Report and an End Case report.

To set up Auto Reports,

- 1 Select **Main Setup, Reports**, then **Auto Reports** and select the Auto Report you want to set up (A, B, C, or D).
- 2 Select **Report** and assign a report type to the Auto Report.
- 3 Select **End Case Report** and switch to **On** if you want the selected report to print automatically when you select **End Case** to discharge a patient.
Switch **End Case Report** to **Off** if the report is a Scheduled Report only.

- 4 Select **Scheduled Rep.** and toggle to **On** if you want the selected report to print at predefined intervals, starting at a predefined time of day. The start time you set applies for every following day. For example, if you set a start time of 07:00 and a repeat time of six hours, the first report will print at 07:00 every day, the next at 13:00 and so on.
 - To set the time of day at which you want the report to print every day: select **Start Hour** and **Start Minute** and select the required time from the pop-up list
 - To set the time interval in minutes between two scheduled reports: select **Rep. Freq. (hrs)** and **Rep. Freq. (min)** and select the time interval from the pop-up list.

If you are setting up an end case report, these settings will be inactive ("grayed-out").

Switch **Scheduled Rep.** to **Off** if the report is an End Case Report only.

- 5 Repeat the procedure for all Auto Reports you want to set up.

All Auto Reports or Scheduled Reports set to **On** print automatically at the predefined trigger.

Be aware that the monitor's memory for reports is limited. The number of reports that can be stored depends on the size of the reports and the size of the printing database; the maximum is 30 reports. If the memory is full, reports cannot be saved on the printing database and therefore cannot be printed.

If you set up regular scheduled reports, and you have long case durations, make sure that the print database is configured to **Large** and plan to print reports at appropriate intervals in order to avoid losing information due to a full memory.

Setting Up Individual Print Jobs

To adjust the appearance of individual print jobs, in the **Reports** menu,

Select **Main Setup, Reports**, then **Setup Reports** to enter the **Setup Reports** menu.

- 1 Select **Report** and then select the report you want to set up.

- 2 Select **Report Type** and then select the reports template you want the report selected in Step 2 to use. The selection of templates listed depends on the report type selected.
Each template includes patient demographic data, and each Realtime Report also includes alarm and INOP information. In addition, the templates include:
VisibleWaves: all waves currently visible, in the order they appear on the screen.
All Waves: all measured waves.
RT Waves: all currently measured realtime waves, according to the monitor's priority list.
HiRes Waves: all measured HiRes waves.
OxyCRG Waves: the OxyCRG/Neonatal Event Review waves.
Vital Signs: trend information in tabular form.
Graph Trend: trend information in graphic form.
ECG reports: **ECG3x4, ECG6x2, ECG12x1, ECG4x2, ECG8x1, ECG12x1 (2P)**
EEG reports: **EEG Report**.
Episode: a single patient event episode.
Review: an overview of patient events
Alarm Limits: a list of all currently set alarm limits.
- 3 Select **Report Size** to set the paper size to be used for the report: **Unspecified** to use the default size for the template chosen, **Universal, A4, Letter, LrgUniversal, A3, or Ledger**. The list of available sizes depends on the report type selected.
- 4 Select **Orientation** to set the orientation of the report printout: **Unspecified** to use the default size for the template chosen, **Landscape** or **Portrait**.
- 5 Select **Target Device** and choose which printer the print job will be sent to: **Unspecified** to use the default printer, or choose from the list of printer names defined at the Information Center or in the monitor's Configuration Mode (for example, **Remote 1** or **Database**).

Some settings may be inactive ("grayed-out") in this menu for reports that can only be started in a special window.

Checking Printer Settings

The printer settings for your monitor are defined in Configuration Mode. The printer settings **Paper Size, Resolution, Color Support, and Duplex Option** for the active printer are visible but inactive ("grayed-out") in the **Setup Printers** menu. When **Print Database** is selected as active printer only the **Paper Size** setting will be shown.

- To enter the **Setup Printers** menu, in the **Reports** menu, select **Setup Printers**.

Printer names for locally-connected printers can be defined in Configuration Mode. You can see whether a specified printer is centrally or locally connected in the **Setup Printers** menu under **Port**. If "Local" is included in the port name, e.g. **Local 2**, that indicates locally-connected printers, and "Remote", e.g. **Remote 1**, indicates centrally-connected printers.

If you are using an IntelliVue XDS Application print service, you may see XDS printers in the **Setup Printers** menu that also have "Local" or "Remote" in their name. Their names and settings can only be configured in the XDS Application. Refer to the IntelliVue XDS Application Installation and Configuration Guide for full details about the configuration possibilities.

Printing a Test Report

A test report can be printed in Configuration mode, refer to the Service Guide for details.

Switching Printers On or Off for Reports

You can enable or disable printer status to switch individual printers on or off for report printouts.

- 1 In the **Setup Printers** menu, select **Printer** and then select the name of the device you want to switch on or off for Reports printing from the pop-up list.
- 2 Select **Printer Status** to switch between the settings **Enabled** and **Disabled**. If you set this to **Disabled**, no reports will be printed to the named printer.

If the monitor detects that no printer of a particular type is available, the **Printer Status** setting will automatically be set to **Disabled** and "grayed out".

Local printers from the XDS Application print service are always enabled and cannot be disabled here.

Dashed Lines on Reports

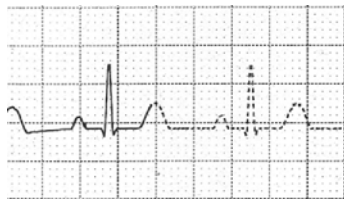

If a section of a wave on a report is drawn with dashed lines, this tells you that a setting that affects the appearance of the wave on the screen was changed while the report was printing.

For example, if you change the wave scale while a report is printing, the wave scale and wave size are changed immediately on the monitor screen and on the report. To indicate that the scale information printed at the beginning of the report no longer matches the currently used scale, the wave will be printed using dashed lines, starting from the moment the change took place.

Some examples of settings that cause dashed lines in reports if changed during printing are: Filter mode, ECG lead placement, wave scale, measurement unit, paced/non-paced setting, and measurement mode. Note that as ECG waves are drawn with a fixed gain on reports (either 10 mm/mV or 20 mm/mV), changing the ECG wave scale will not cause dashed-line reports.

To avoid dashed lines on reports, wait 15 seconds after changing a setting before you trigger a report.

Unavailable Printer: Re-routing Reports

If you send a report to be printed on a printer that is not available, for example, because it has run out of paper, this print job is suspended and stored in the monitor's memory.

If the target device of this print job was set to **Unspecified**, the monitor will periodically try to resend the print job to the first printer listed in the **Setup Printers** menu under **Printer** that is set to **Enabled** and that has paper of the correct size.

To allow the report to print, you must either solve the problem with the target printer, or re-route the print job to another printer with paper of the correct size. To re-route a print job,

- Enable the new target printer by selecting it in the **Setup Printers** menu and toggling to **Enabled**. As the monitor tries to send the report to the printers in the order they are listed, you must make sure that all the printers above the new target printer are disabled.

If the target device of the print job was set to a specific printer, re-routing is not possible.

Checking Report Status and Printing Manually

A list of all print requests which are waiting, printing or stored can be viewed in the **Reports Job List**. To view the list, in the **Reports** menu, select **Reports Job List**.

The following information is displayed for each print request:

- Report title
- Patient name (except for system reports)
- Request date and time
- Report paper format
- Job status: **Preparing, Printing, Waiting, In Database, In Companion, Retry, Cancelling, Error**.

Individual reports can be deleted from the list with the **Delete Report** key, and all reports with the **Delete All Repts** key.

CAUTION

The **Reports Job List** includes privacy information, in the form of the patient name with the related report title and date. It is advisable to provide controlled access to this data to ensure confidentiality.

If an X2 is connected to a host monitor, all print requests which are stored in the print database are shown "grayed out" on the **Reports Job List** and will not be deleted with the **Delete All Repts** key.

Printing Manually

Those jobs shown in black will be printed automatically when a matching printer is available. If the **Auto Print Dbs** setting is **Host Only** or **Never**, some or all reports will not be printed automatically and will be shown in gray. Any jobs shown in gray must be printed manually; to do this,

- 1 In the **Reports Job List**, select the required report
- 2 Select **Print Report**.

Selecting **Print All Repts** will send all reports to the printer.

Printer Status Messages

Printer Status Message	Possible causes and suggested action
Print job queued for <Printer Name>	The report has been placed in the queue for the named printer.

Printer Status Message	Possible causes and suggested action
<p>Print job could not be queued (insufficient resources)</p> <p>Print job could not be queued (queue is full)</p> <p>Print job could not be queued (no matching printer found)</p>	<p>The printer queue is full and the monitor cannot accept another report request. Wait until some more reports have been printed, then try again, OR</p> <p>A report has been triggered that uses a paper size unavailable with the target printer. Try another printer, if available, or change the paper size of the print request.</p>
Cancelling all print jobs	<p>Delete All Reps has been selected in the Reports menu, OR</p> <p>The Operating Mode has been changed from Monitoring Mode to Demonstration or Service Mode.</p>
Cancelling the active print job	The current report is being canceled as the result of a user request.
Cancelling print jobs due to patient discharge	When a patient is discharged, all queued reports are canceled except those stored in the print database.
Cancelling # print jobs due to hotstart	The monitor has restarted and all report requests have been canceled except those stored in the print database. "#" is the number of reports canceled.
Printing failed: No report configured!	A report has been triggered which has not been correctly set up. Enter the setup menu for the report type to set up the report.
Printing on <Printer Name>...	A report is in progress, or the monitor is waiting for the central printer to accept the print job.
Printer <Printer Name> unavailable -> job suspended	The chosen device is unavailable. Check that the printer is properly connected and that paper is available. The requested report will start printing when the printer becomes available.
Print database full -> job suspended	The requested report does not fit into the print database. You can select another printer to print the report (see "Unavailable Printer: Re-routing Reports" on page 374). Alternatively you can delete another report from the Reports Job List (using the Delete Report key) to create space for your report.
<p>Job on <Printer Name> failed (data unavailable)</p> <p>Job on <Printer Name> failed (printer unavailable)</p> <p>Job on <Printer Name> failed (data requisition error)</p>	<p>A report cannot be started on the requested printer. One of three reasons is shown in the status message:</p> <ul style="list-style-type: none"> • data unavailable - the connected X2 has been removed before the data for the report was transferred. • printer unavailable - make sure the printer is plugged in, switched on, and has paper loaded. • data requisition error - an internal error has caused data required for the report to be unavailable, try starting the report again.
Print job on <Printer Name> done	The report has been printed.

Sample Report Printouts

Each report header contains the patient's bed label, last name and first name, middle name (if there is enough space) the patient ID, the date and time, and the name of the report. The report footer contains the hospital label and page number, and the last page contains a note to mark the report end.

The monitor may be configured to leave a space on the top left or right of the report printout to enable you to stick a patient address label on it. This setting is called the **Addressograph** and it can only be changed in the monitor's Configuration Mode.

Alarm Limits Report

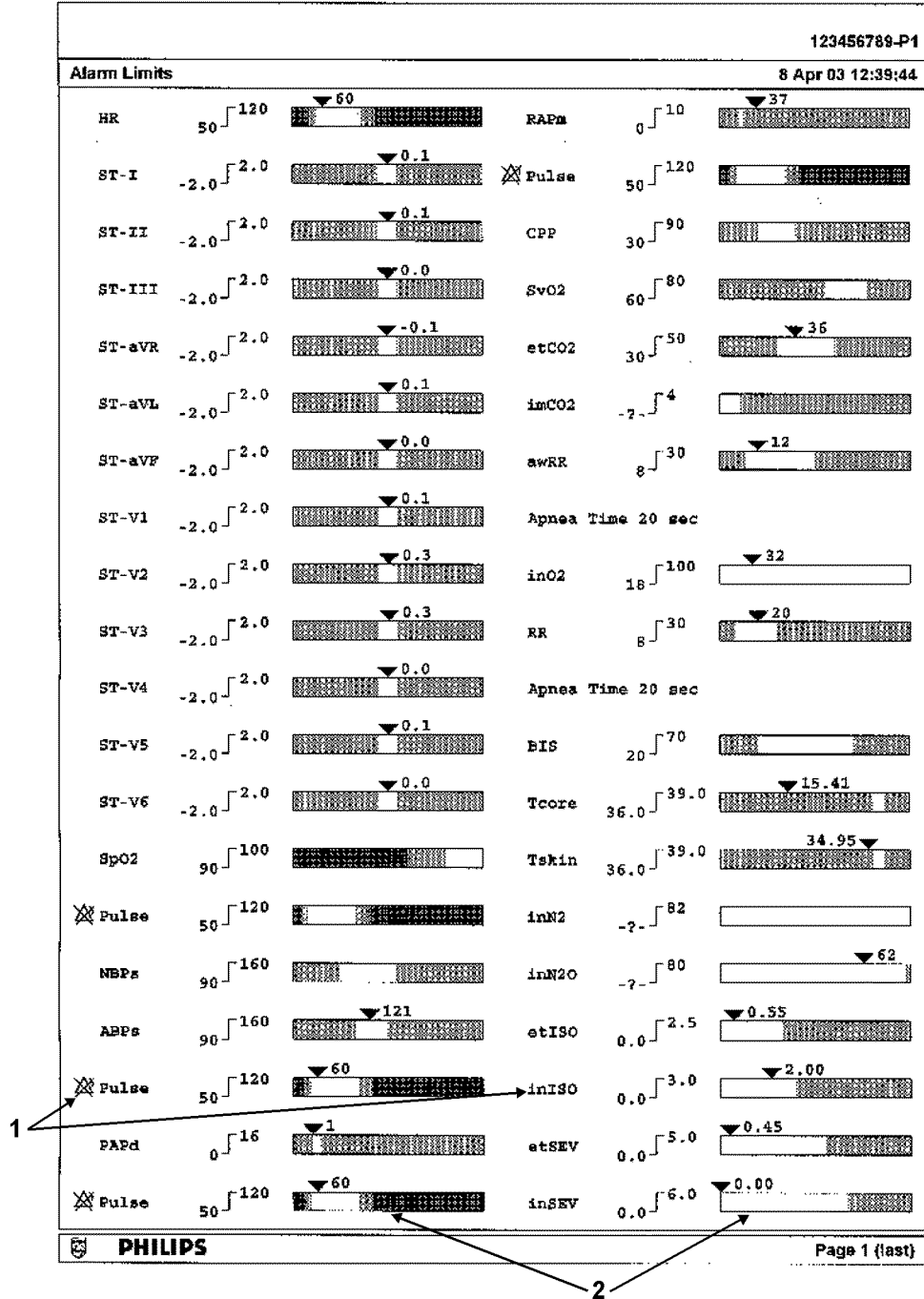

- 1 Measurement labels, with alarms off symbol where alarms are switched off
- 2 Graphic view of current alarm limits in relation to currently monitored measurement value

Realtime Report



- 1 Patient demographic information, time stamp
- 2 Active Alarms and INOPs, followed by vital signs
- 3 Measurement waves section

Cardiac Output Report

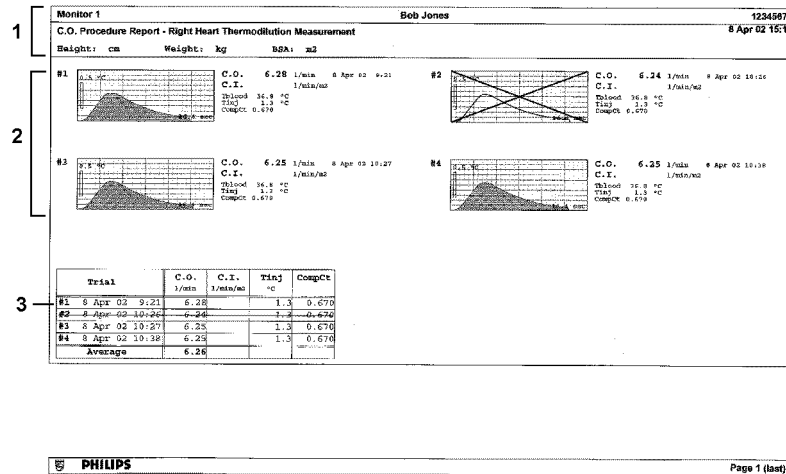

- 1 Patient information
- 2 Numbered trial curves
- 3 Trial information in tabular form

ECG Reports

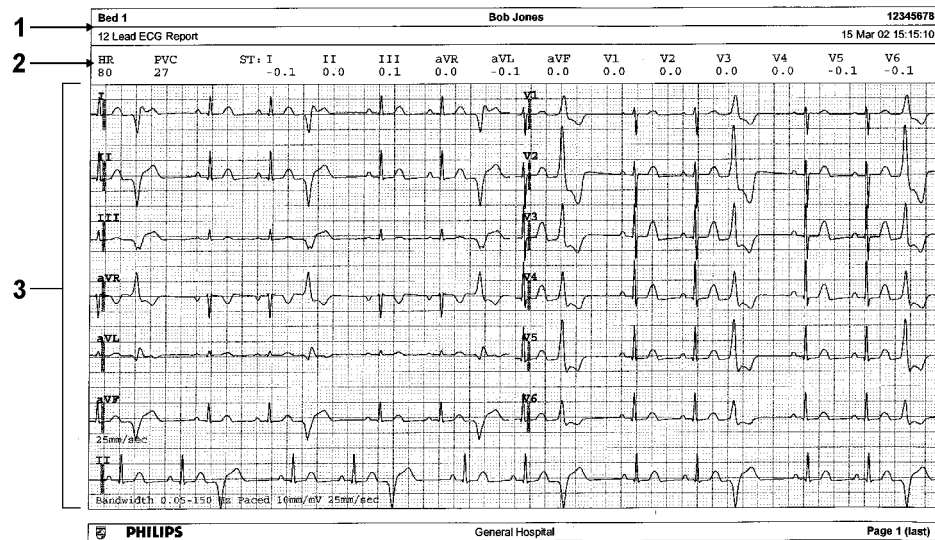

- 1 Patient information
- 2 Numeric block
- 3 Wave area

Below the header on ECG Reports, the numeric block shows the current HR, PVC, and ST values. The wave area shows the printed waves for all available ECG leads. A 1 mV calibration bar is printed at the beginning of each wave. With the 3X4, 6X2, and 2X4 formats, a rhythm stripe prints a longer section of the ECG wave from the primary ECG lead for ECG rhythm evaluation. The ECG signal bandwidth, the patient's paced status, the ECG gain, and the print speed are printed at the bottom of the wave area. Pace pulse marks are automatically printed beside the wave for paced patients. Beat labels can be set to print on the rhythm stripe. The 12X1 (2P) format prints the report over two pages.

ECG Report type	Available Formats	Available Paper Sizes
12-Lead ECG	3X4 landscape	A4, letter, A3, ledger
	6X2 landscape	A4, letter, A3, ledger
	12X1 portrait	A4 and letter only
	12X1 landscape	A4, letter, A3, ledger
	12X1 (2P) landscape	A4, letter (2 pages)
Multi-lead ECG	2X4 landscape	A4, letter, A3, ledger
	8X1 portrait	A4 and letter only
	8X1 landscape	A4, letter, A3, ledger

12-Lead ECG Report

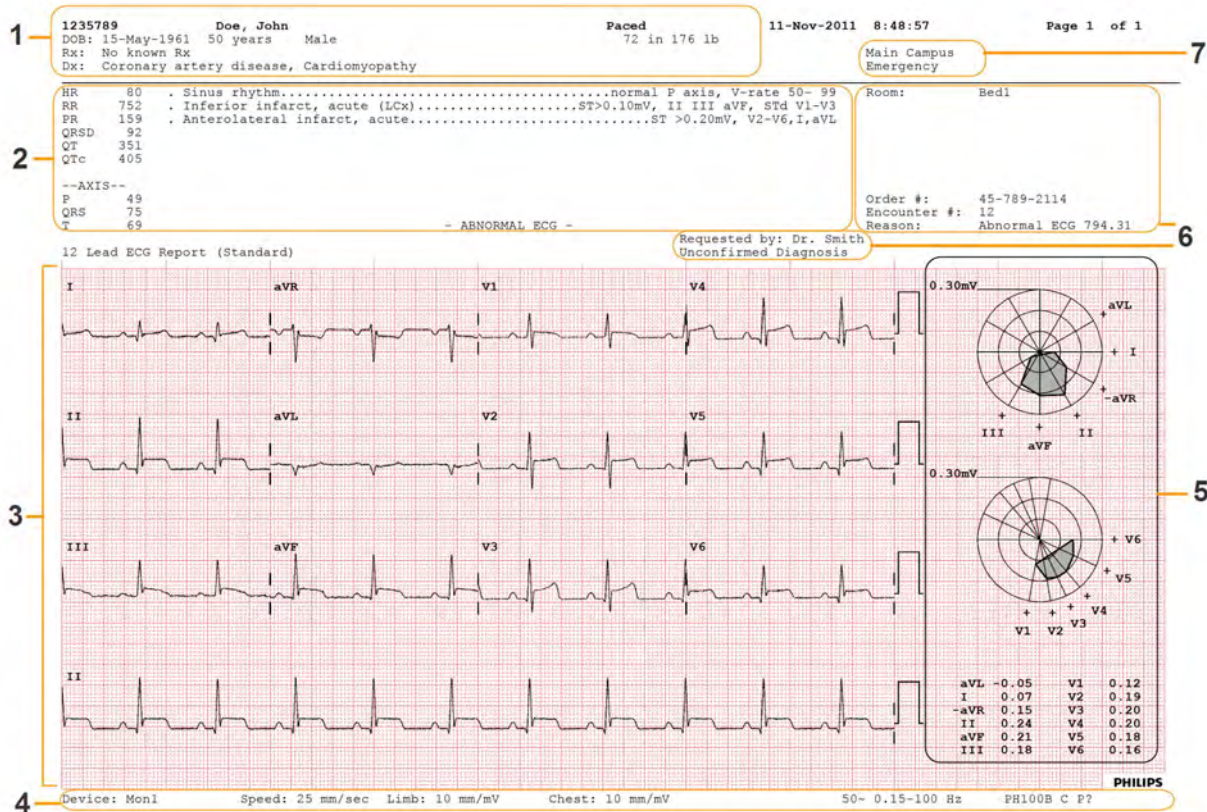

- 1 Patient data
- 2 Analysis data from the Information Center (PIIC iX only)
- 3 12-Lead wave area
- 4 Data related to the wave presentation
- 5 ST Map with related ST numerics (optional)
- 6 Administrative data - including optional custom text fields
- 7 Hospital ID data - Institution, facility and department, if configured

Other Reports

See the sections on Trends and Calculations and the chapter on Event Surveillance for other example reports.

Using the Drug Calculator

Drug mixtures for intravenous (IV) drug infusions combine information on drug dose, rate, amount, volume, concentration, and standardized rate. The Drug Calculator helps you to manage infusions by calculating one of these values at a time.

Term	Definition	Units
Dose	total quantity of drug to be delivered to the patient over time	amount units per time or per kg/time, if the drug is weight-dependent
Rate	volume of the mixture to be delivered to the patient over time	ml/hour
Amount	amount of drug to be added to diluent to make up a mixture	ng, mcg*, mg, g, mUnit, Unit, where g stands for gram
Volume	quantity of mixture of diluent and drug	ml
Concentration	ratio of the amount of drug to the solution volume	amount units per ml
Standardized Rate	1 ml volume of the mixture to be delivered to the patient per hour	ml/hr

*Be aware that your hospital may use either ' μg ' or 'mcg' as an abbreviation for microgram. These abbreviations are equivalent.

WARNING

Before you administer any drug, always check that the correct calculation units and patient category are selected. Consult your pharmacy if you have questions.

Decisions on the choice and dosage of drugs administered to patients must always be made by the physician in charge. The Drug Calculator performs calculations based on the values input during use, it does not check the plausibility of the calculations performed.

Accessing the Drug Calculator

To access the Drug Calculator, select **Main Setup** then **Calculations** followed by **Drug Calculator**, or

select the  **Drug Calc** SmartKey, if configured.

Performing Drug Calculations

Using the service Support Tool, a list of drugs can be configured for the monitor containing pre-defined dosage recommendations and unit settings. Selecting the arrow beside the drug name in the **Drug Calculator** window opens a list of configured drugs. Contact your pharmacist if you have any questions about the drugs in the list.

If **ANY DRUG** is the only entry in the list of drugs, no drugs have been pre-configured for your monitor. Drug calculations can be performed for non-specific drugs.

You must have a Support Tool to add additional drugs to the Drug Calculator.

About the Rule of Six

If the Rule of Six has been enabled for use with individual drugs in your Drug Calculator, you can use the formula in crisis situations to quickly calculate the amount of a drug needed to yield a target dose for continuous infusion for neonatal or pediatric patients (the drug amount is given in "mg", the patient weight in "kg"). The Rule of Six can only be used with the dose unit mcg/kg/min.

CAUTION

JCAHO (Joint Commission of Accredited Healthcare Organizations) recommends disabling the Rule of Six. The configuration is not JCAHO-compliant if Rule of Six is enabled.

The Drug Calculator uses the following formula for Rule of Six calculations, based on the patient's weight:

- For a target dose of 0.1 mcg/kg/min, the Drug Calculator multiplies 0.6 x patient weight to calculate the amount you need to add to the IV solution to equal a total of 100 ml.
- For a target dose of 1.0 mcg/kg/min, the Drug Calculator multiplies 6.0 x patient weight to calculate the amount you need to add to the IV solution to equal a total of 100 ml.

Performing Calculations for a Non-Specific Drug

The screenshot shows the 'Drug Calculator' window with the following fields and values:

Field	Value	Unit
Drug Selection	ANY DRUG	
Dose	2	mg/min
Rate	480	ml/hour
Amount	25	mg
Volume	100	ml
Concentr.	0.25	mg/ml
1 ml/hr	0.004	mg/min
Weight	150	lb

Annotations in the image:

- 1: Points to the 'ANY DRUG' selection dropdown.
- 2: Points to the 'Dose', 'Rate', 'Amount', and 'Volume' input fields.
- 3: Points to the 'Concentr.' and '1 ml/hr' calculated fields.
- 4: Points to the 'Weight' input field.

- 1 **ANY DRUG** selection
- 2 Entry fields for **Dose**, **Rate**, **Amount**, and **Volume**
- 3 Calculated standardized rate (**1 ml/hr**) and concentration (**Concentr.**)
- 4 **Weight** used for weight-dependent dose units

If a list of drugs has not been configured for your monitor, you can use the Drug Calculator to calculate drug doses for a single, generic drug called **ANY DRUG**. Selecting the arrow beside the drug name in the **Drug Calculator** window shows that there are no other drugs configured.

- 1 Enter three of these four values: dose, amount, volume, rate of the infusion solution.
To enter values, select the correct unit, then select each value field and use the pop-up keypad to enter the correct value.
- 2 If you have chosen a weight-dependent dose unit, you must enter the patient weight now or choose a different unit.
If available, the patient weight from the **Patient Demographics** window is entered automatically in the **Drug Calculator** window when the Drug Calculator is accessed. To change the patient weight, select the **Weight** key then use the on-screen keypad to enter the correct value. This will not change the patient weight stored in the patient demographic information.
- 3 When you have entered three values, the Drug Calculator automatically calculates the unknown fourth value and shows it in the highlighted field. Standardized rate and concentration are also calculated.

Performing Calculations for a Specific Drug

The screenshot shows the 'Drug Calculator (Adult)' window for 'Demo Dobutamine'. It features a 'Patient Category' dropdown set to 'Adult'. Below it are input fields for 'Dose' (40 mcg/kg/mn), 'Rate' (163.29 ml/hour), 'Amount' (250 mg), 'Volume' (250 ml), and 'Concentr.' (1 mg/ml). A 'Weight' field is set to 150 lb. A 'Reset Values' button is located at the bottom left. On the right, a vertical scale displays the current calculated value (163.29) in green, with a recommended range from 200 to 250 also shown in green. Values outside this range would be shown in red.

- 1 Patient category (**Adult**, **Pedi**, **Neo**)
- 2 Entry fields for **Dose**, **Rate**, **Amount**, and **Volume**
- 3 Calculated standardized rate (**1 ml/hr**) and concentration (**Concentr.**)
- 4 **Reset Values** key reverts to the configured values for this drug
- 5 **Weight** used for weight-dependent dose units

- 1 Select the arrow beside **ANY DRUG**, then select the required drug from the list of drugs. This opens the window for the selected drug.
- 2 Select the correct patient category for your patient. If you have a neonatal or pediatric patient, the **Rule of 6** choice may be available. Select if required.
- 3 Enter the patient weight, if necessary. If available, the patient weight from the **Patient Demographics** window is entered automatically in the **Drug Calculator** window. To change the patient weight, select the **Weight** key then use the on-screen keypad to enter the correct value. This will not change the patient weight stored in the patient demographic information. Select the weight unit shown to change between lb and kg.
- 4 When a specific drug is selected, the initial values for **Dose**, **Amount** and **Volume** are the configured Start values for this drug. The **Rate** is then calculated. If other values are required you can calculate any value by entering the remaining three values as described in “Performing Calculations for a Non-Specific Drug” on page 383.

The column on the right of the window shows either drug dose or dosage rate, whichever is the calculated value. The current calculated value is shown on a scale with the recommended range in green. If the current calculated value lies outside the recommended range it is shown in red.

If you have changed values in the Drug Calculator and you want to revert to the configured values, select **Reset Values** key at any time.

Charting Infusion Progress

Dobutamine			Amount	Volume	Drip Time
			16.67	16.67	0:21:36
			33.33	33.33	0:43:12
Dose	12 mcg/kg/mn		50	50	1:04:48
			66.67	66.67	1:26:24
Rate	46.38 ml/hour		83.33	83.33	1:48:00
			100	100	2:09:36
Amount	250 mg		116.67	116.67	2:31:12
			133.33	133.33	2:52:48
Volume	250 ml		150	150	3:13:48
			166.67	166.67	3:35:24
Weight	142 lb		183.33	183.33	3:57:00
			200	200	4:18:36
Drip Time	5:23:24 hr:min:sec		216.67	216.67	4:40:12
			233.33	233.33	5:01:48
			250	250	5:23:24

The **Drip Table** shows you at a glance how much of the infusion has been administered to your patient and how much time is left.

- To see the **Drip Table**, in the **Drug Calculator** window, select the **Drip Table** pop-up key.

If the Drip Time exceeds 24 hours, the Drip Time timestamp shows:

---:--:---.

Using the Titration Table

Dobutamine			Dose	12 mcg/kg/mn			
3	Dose increments		Rate	46.38 ml/hour			
	From a low of	0 mcg/kg/mn	Amount	250 mg			
2	To a high of	50 mcg/kg/mn	Volume	250 ml			
	In increments of	1 mcg/kg/mn	Weight	142 lb			
Dose	Rate	Dose	Rate	Dose	Rate	Dose	Rate
1	3.86	11	42.51	21	81.16	31	119.8
2	7.73	12	46.38	22	85.02	32	123.67
3	11.59	13	50.24	23	88.89	33	127.53
4	15.46	14	54.1	24	92.75	34	131.4
5	19.32	15	57.97	25	96.62	35	135.26
6	23.19	16	61.83	26	100.48	36	139.13
7	27.05	17	65.7	27	104.34	37	142.99
8	30.92	18	69.56	28	108.21	38	146.85
9	34.78	19	73.43	29	112.07	39	150.72
10	38.65	20	77.29	30	115.94	40	154.58

- Currently set values for **Dose**, **Rate**, **Amount**, **Volume**, and **Weight**.
- Minimum dose, maximum dose and increments used for the table.
- Shows whether **Dose increments** or **Rate increments** are the basis of the table.

Use the **Titration Table** to see at a glance what dose your patient would receive of a drug at different infusion rates. By clicking on the blue title row of the table you can switch between the **Dose increments** and **Rate increments** view.

Values outside of the recommended range are shown in red.

To see the **Titration Table**,

- in the **Drug Calculator** window, select the pop-up key **Titr. Table**.

The **Titration Table** is configured with the service Support Tool.

Documenting Drug Calculations

- In the **Drug Calculator** window, select the pop-up key **Record DrugCalc** to immediately start a recording of the current drug calculation.
- In the **Titration Table** window, select the pop-up key **Print Titr.Tbl** to print a report of the current Titration Table.
- In the **Drip Table** window, select the pop-up key **Print Drip Tbl** to print a report of the current Drip Table.

VueLink Modules

A VueLink module transmits information from a connected external device to your monitor. Each module can be connected to one of up to three preselected external devices, and supports alarms from the external device. Data from VueLink modules cannot be included in monitor trends when the label is a free-text label.

The external device may show more information than is available on the monitor. The number of waves and numerics you can view simultaneously on your monitor's main screen depends on the module type. Type A modules support one wave and two numerics, type B modules support two waves and six numerics.

Module	Type	Max. Wave	Max. Numeric	External Devices
Auxiliary	A	1	2	standalone measurement module
Ventilator	B	2	6	ventilators
Gas Analyzer	B	2	6	gas analyzers
Anesthesia Machine	B	2	6	anesthesia machines
Auxiliary Plus	B	2	6	external multi-measurement devices

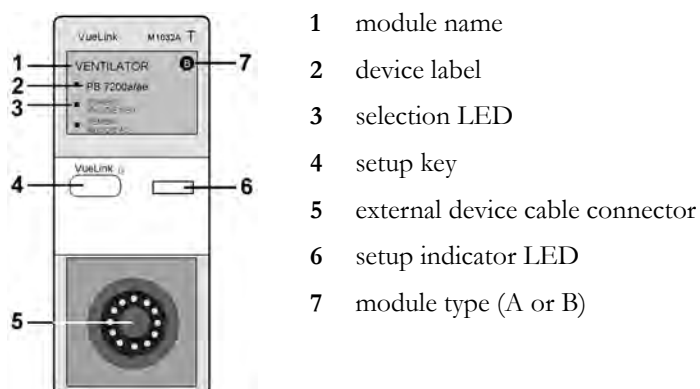

The device labels (2) on the module indicate for which external devices the module is configured. The selection LED (3) shows which device is currently active. The device label text may differ slightly from the labels on the external devices.

See the documentation supplied with the VueLink module for a list of supported devices and accessories, and for configuration information.

Connecting an External Device

- 1 Insert the module into the FMS or integrated module slot.
- 2 Check that the device selection LED (3) lights to show that it has correctly identified the external device. If not, select **Main Setup, Measurements** and then the name of the external device to enter the setup menu for the connected device.
- 3 In the device setup menu, select **Device**, select the correct device from the list, and confirm the selection.
- 4 Connect the external device to the module and switch it on.

Once the VueLink device has been correctly connected, you can select the **External Devices** SmartKey and then select the **Setup Device** pop-up key to access the setup menu for the connected device.

CAUTION

Selecting the wrong device can cause unpredictable system behavior. Rectify this by switching off the external device when it is safe to do so, and selecting the correct device.

Changing VueLink Waves and Numerics Displayed

To change the waves and numerics from the VueLink module displayed on the Screen,

- 1 Select **Main Setup, Measurements** and then the name of the connected device to enter its setup menu.
- 2 Select the item you want to change, then select the new item from the pop-up list,
or
Select **Show Device Data** to view the device data window.
- 3 Close the setup menu. The monitor takes a few seconds to activate the change.

Viewing the VueLink Device Data Window

VENTILTR					
3 — VENTILATOR					
2 — VENTILATOR SIMULATOR					
1 — VENTILATION MODE:		MODE1	Device Alarms Accepted — 4		
NBP _s	200 mmHg	TV	1.60 liter	PIP	50 cmH ₂ O
NBP _d	30 mmHg	MINVOL	4.60 L/min	PEEP	18.0 cmH ₂ O
NBP _m	60 mmHg	SpMV	4.60 L/min	MinAwP	24.0 cmH ₂ O
inO ₂	64 %	awRR	110 rpm	P _{max}	70 cmH ₂ O
etCO ₂	5.00 %	sAwRR	28 rpm	AwP _{min}	4 cmH ₂ O
imCO ₂	6.5 %	SpRR	100 rpm	P _{plat}	10 cmH ₂ O
COMP	64 mL/cmH ₂ O	SpO ₂	59 %	sIE I:	1.135
Raw	32 cmH ₂ O/L/s	Pulse	120 bpm	sPtCat	ADULT

- 1 Mode information from external device
- 2 Name of external device
- 3 Type of external device
- 4 **Device Alarms Accepted**

To view the VueLink device data window, either

- select the setup hardkey on the VueLink module or the **External Devices** SmartKey, and then select the pop-up key for the device, or
- in the **Setup <External Device>** menu, select **Show Device Data**.

Select the device data window then the **Setup Device** key to open the setup menu for the connected device.

Using VueLink Screens

Your monitor may be configured to show VueLink device data permanently on the Screens.

Select the device data window to display the external device pop-up keys that let you access the setup menu and carry out external device tasks.

Switching VueLink On and Off

- To switch VueLink measurements on and off, in the setup menu for the external device, select **Device Interface** to toggle between the settings **On** and **Off**.

Alarms/INOPs From External Devices

The VueLink module itself generates INOPs, but does not generate alarms. If the external device's alarms are on, the module transmits these to the monitor. A message in the VueLink info window tells you, depending on the configuration setting, either **Device Alarms Ignored** or **Device Alarms Accepted** or, when the external device is not supplying alarm data, **No Alarms Available**.

When **Device Alarms Ignored** is set, alarms from the external device will not be displayed on the monitor and will not be transmitted to the Information Center. External device alarms status symbols precede some, but not all, measurement labels.

	the monitor is configured to accept external device alarms, but the alarms are switched off at the external device.
!	alarms status of this external measurement is unknown

Alarms from external devices are:

- transmitted to the monitor. For all numerics configured in the setup menu, an alarm condition is announced at the monitor. For one or more measurements not configured in the setup menu, an alarm is announced as a text message for the highest priority alarm. Priority is determined at the external device.
- always non-latching on the monitor.
- announced as a flashing numeric while the alarm condition persists.
- announced audibly and visibly at the Information Center.

Language Conflict with External Device Drivers

You should avoid language conflicts between the VueLink module device driver and the monitor. Be aware that if you connect a VueLink module with a different operating language to the monitor, the monitor will show:

- measurement labels in the monitor language
- alarm and INOP texts in the VueLink module device driver language.

IntelliBridge EC10

An IntelliBridge EC10 module or Interface board (for MX400/450/500/550) transmits information from a connected external device to your monitor. The IntelliBridge EC5 ID module is used to provide identification information from the external device. Data imported from the external device, for example waveforms, measurement numerics, settings and alarms, can be displayed on the monitor, passed on to an Information Center and included in trends as appropriate. The external device may show more information than is available on the monitor. Data from IntelliBridge EC10 cannot be included in monitor trends when the label is a free-text label.

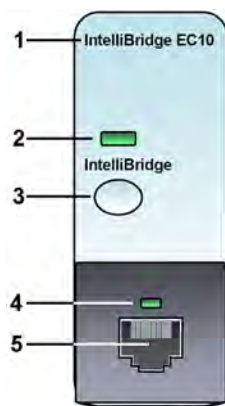

Module

- 1 module/interface board name
- 2 setup indicator LED
- 3 setup/data viewing key
- 4 connection status LED
- 5 external device cable connector



Interface Board

See the documentation supplied with the IntelliBridge EC5 ID module for a list of supported devices and accessories, and for configuration information.

Connecting an External Device

- 1 *When using the module:* Insert the module into the FMS or integrated module slot.
- 2 Check that you have the correct EC5 ID module for the external device - indicated on the EC5 label.
- 3 Connect the EC5 ID module to the external device.
- 4 Connect the EC5 to the EC10 module or Interface board using the supplied cable.
- 5 Switch the external device on.

- The connection status LED (4) will flash green until it has correctly identified the external device and started communication. Check that the connection status LED then lights green continuously indicating that communication has been established.

Changing Waves and Numerics Displayed

To change the waves and numerics from the IntelliBridge module or Interface board displayed on the Screen,

- Select **Main Setup, Measurements**, then **<External Device>** to enter the setup menu for the connected device.
- Select **Setup Driver**.
- Select **Setup Waves** or **Setup Numerics** and make the changes required.
- Close the setup menu. The monitor takes a few seconds to activate the change.

Viewing the IntelliBridge Device Data Window

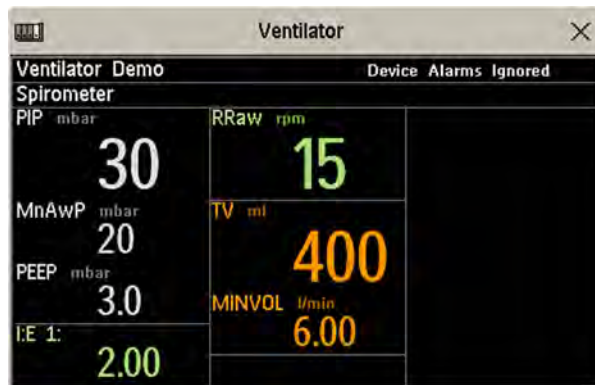

To view the IntelliBridge device data window, either

- select the setup key on the IntelliBridge module, if available, or
- select the **External Devices** SmartKey and then select the pop-up key with the device name on it, or
- in the **Setup <External Device>** menu, select **Show Device Data**.

Check that the correct external device ID is shown in the window title.

Select the device data window then **Setup Device** to open the setup menu for the connected device.

With the **More Data** key you can page through additional data which does not fit on the first screen.

When an infusion system is connected the data is presented differently. The data from each pump is displayed in a horizontal frame in the window. Data from several infusion pumps can be displayed.

To see a detailed information window for one of the pumps, you can select data for that pump on the Screen or select the **More Data** pop-up key.

Using Screens with External Device Data

Your monitor may be configured to show external device data permanently on the Screens.

Select the device data window to display the pop-up keys that let you access the setup menu and make changes.

Alarms/INOPs from External Devices

The IntelliBridge module/Interface board itself generates INOPs, but does not generate alarms. If the external device's alarms are on, the module/Interface board transmits these to the monitor. A message in the External Device Data window tells you either **Device Alarms Ignored** or **Device Alarms Accepted** or **No Alarms Available**. External device alarms status symbols precede some, but not all, measurement labels.



the monitor is configured to accept external device alarms, but the alarms are switched off at the external device.

Alarms from external devices are transmitted to the monitor. For all numerics configured in the setup menu, an alarm condition is announced at the monitor. For one or more measurements not configured in the setup menu, an alarm is announced as a text message for the highest priority alarm. Priority is determined at the external device.

Refer to the documentation supplied with the IntelliBridge EC5 ID module for details of how alarms are announced on the monitor and the Information Center.

INOPs from the IntelliBridge Module/Interface Board

INOP Text	INOP Condition
!!No Device Data !!!No Device Data	Communication has been lost to a connected device when <ul style="list-style-type: none"> – !! a medium priority INOP or patient alarm was present – !!! a high priority INOP or patient alarm was present
No Device Data	Communication has been lost to a connected device with no (or only low priority) INOPs/physical alarms.
Device Unsupported	Device identification completed but no appropriate device driver installed
Device Chk Config	Device identification completed but communication could not be established due to errors
Device Check Setup	Device identification completed but communication could not be established due to timeout

Using Timers

With the Timers function you can set timers to notify you when a specific time period has expired.

CAUTION

Do not use the timers to schedule critical patient-related tasks.

Viewing Timers

You can view currently active timers in the **Timers** window or directly on the Main Screen (if a timer has been substituted for a numeric).

To open the **Timers** window:

- Select the **Timer** SmartKey 
- or
- Select **Main Setup** then select **Timer**

The maximum number of timers which can be active depends on your monitor model.

For a timer with a defined run time a progress bar is shown with the run time for that timer. Next to the progress bar the elapsed time or the remaining time is shown, depending on whether the timer is counting up or down. On the left, the label of the timer and a symbol indicating the type of expiry notification is shown.

Timer Types

There are four types of timer: **Basic**, **Enhanced**, **Cyclic** and **No Limit**. A **Basic** timer has a single, defined run time and progress is shown in the progress bar. An **Enhanced** timer is like a **Basic** timer but the progress bar shows progress beyond the end of the run time. A **Cyclic** timer is like a **Basic** timer but restarts automatically when the run time is expired. A **No Limit** timer has no run time or progress bar and shows the time elapsed since the timer was started.

The type of timer is set in the monitor's Configuration Mode and is associated with the timer label.

Timer Setup Pop-up Keys

When you open the **Timers** window and select a timer, then select the setup key, the setup window opens and a selection of pop-up keys appear to let you activate and control the timers.

Pop-Up Keys	Selecting this pop-up key lets you....
Start	start the timer.
Stop	stop the timer, allowing either restarting after a pause (Start key) or clearing (Clear key).
Clear	clear the timer, ending this timer episode.
Timers	return to the timer window showing all active timers

Setting Up Timers

The timer type, display color of the timer and whether a window automatically pops up on expiry are settings made in Configuration Mode for each timer label.

The remaining timer settings can be made in Monitoring Mode. If you change settings when a timer is running it will not be stopped. The timer will continue to count but the new settings will be applied.

To display the setup window for a timer,

- in the **Timers** window, select the required timer, then select the setup key or
- select a timer on the Screen then select **Setup Timers**.

Timer Label

You can select from a variety of specific labels, for example **Tourniquet**, **Infus**, **Docu** or from four non-specific labels **TimerA**, **TimerB**, **TimerC**, and **TimerD**. When you assign a label to a timer, the monitor automatically applies the associated configuration settings to this timer, but the timer continues counting and is not reset.

To select a label, in the **Timers** window:

- 1 Select the required timer and display the **Setup** window.
- 2 Select **Label**.
- 3 Select a specific or non-specific label from the list.

Run Time

The run time can be set between 1 minute and 96 hours. **No Limit** timers have no run time.

To set the run time, in the **Timers** window:

- 1 Select the required timer and display the **Setup** window.
- 2 Select **Run Time**.
- 3 Select a run time from the list.

Timer Counting Direction

Timers can count up or down, showing elapsed time or remaining time. **No Limit** timers automatically count up.

To change the direction, in the **Timers** window:

- 1 Select the required timer and display the **Setup** window.
- 2 Select **Direction** to switch between **Up** and **Down**.

Notification

When a timer expires (except a **No Limit** timer), the color changes to red and a message appears in the status line on the Main Screen. Be aware that if a timer has been configured to display in light red, the color will not visibly change when the timer expires.

Additional notification is also available and can be set to:

Alarm: An INOP alarm indicates the expiry of the timer

Sound: A single tone indicates the expiry of the timer

No Sound: No additional notification

To set the additional notification, in the **Timers** window:

- 1 Select the required timer and display the **Setup** window.
- 2 Select **Notification** and select the notification level required from the list.

Timer Volume

For all Timers with the notification setting **Sound**, you can set the volume of the tone.

To set the volume, in the **Timers** window:

- 1 Select the required timer and display the **Setup** window.
- 2 Select **Timer Volume** and select a volume setting from the list.

Displaying a Timer On The Main Screen

If you want to have a timer displayed on the Main Screen, you can substitute it for a numeric which is not directly associated with a wave. If limited space is available, some of the timer display elements may not be displayed. The minimum information displayed is the label and the elapsed or remaining time.



To display a timer on the Main Screen:

- 1 Select the numeric you want to substitute.
- 2 Select **Change Numeric**.
- 3 Select **Any Timer**.

Main Screen Timer Pop-up Keys

When you select a timer displayed on the Main Screen, additional pop-up keys become available:

Pop-Up Keys	Selecting this pop-up key lets you....
Setup <Timer Label>	enter the setup screen for the currently selected timer.
Change Timer	select a different timer for display.
Timers	enter the Timers window.

Displaying A Clock On The Main Screen

In the same way that you can substitute a timer for a numeric, you can also substitute a larger analog or digital clock display for a numeric.

To display a clock on the Main Screen:

- 1 Select the numeric you want to substitute.
- 2 Select **Change Numeric**.
- 3 Select **Clock**.

When you select the clock on the Main Screen you can select **Date, Time** in the menu to set the date and time.

Respiratory Loops

Using a Spirometry module or a VueLink/IntelliBridge module connected to a ventilator, you can measure and store graphic representations of realtime respiratory loops. Respiratory loops can help you recognize changes in your patient's lung function, and they can also indicate a fault in the airway tubing (for example, if the respiratory loop does not close).

You can measure:

- Pressure-volume loops
- Pressure-flow loops
- Volume-flow loops.

Note that you cannot store loops from different patients and different source devices in the same list as they are patient and device specific. This prevents you from inadvertently comparing information from different patients.

Viewing Loops

In the loops display, the current loop is drawn in white, and up to six stored loops are color-coded to match their timestamps. The currently-used source device is shown in the window title.

To view respiratory loops permanently on your Screen,

- select the current Screen name to open the **Change Screen** menu, then select a Screen configured to display the loops screen element.

Select the loops screen element to access the loops pop-up keys.

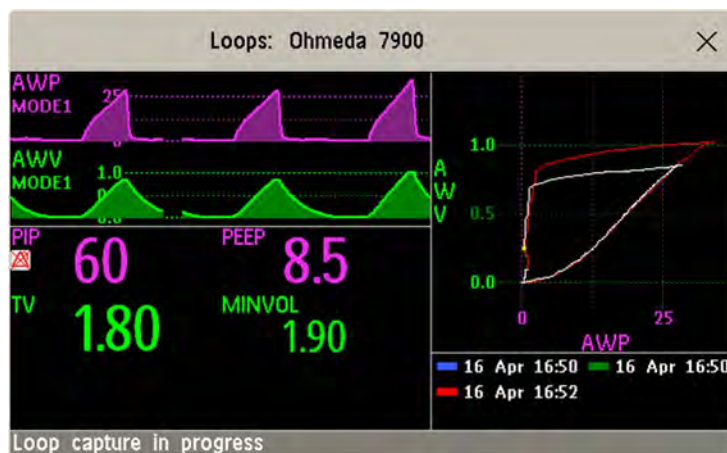

To open the **Loops** window, and its associated pop-up keys,

- select **Main Setup** then **Loops**, or select the **Loops** SmartKey, if configured.

In the **Loops** window, in addition to the stored loops, two realtime airway waves and up to nine available numerics from the source device can be shown.

Capturing and Deleting Loops

Up to six loops of each kind can be stored for reference.

To capture the current Loop and display it in the **Loops** window,

- select the **Capture Loop** pop-up key.
The monitor will prompt you to save the loop for reference, either in addition to or in place of previously stored loops.
Status messages at the bottom of the window provide information on the loop capture process.

To delete Loops from the reference list,

- Select the **Select Loop** pop-up key to view the list of stored loops and delete the loops from the list.

Showing/Hiding Loops

Colored rectangles beside the loops timestamps and color-coded with the loops tell you whether each loop is currently displayed or not:

- A filled-in rectangle marks loops currently shown in the **Loops** window
- A rectangle outline marks loops not currently shown.

Selecting the timestamp of the currently-displayed loop hides it and shows the next in the list; selecting the timestamp of a currently hidden loop displays it.

Changing Loops Display Size

To change the loops display size, in the **Loops** window, select the pop-up key **Select Size** then select

- **Size x0.5** to display loops at half the usual size
- **Size x1** to display loops at the usual size
- **Size x2** to display loops at twice the usual size

This does not affect the size of loops printed in reports.

Using the Loops Cursor

To view the coordinates for any point on a stored loop,

- 1 Select the pop-up key **Select Loop**.
- 2 Select the required loop from the list of available loops.
- 3 Use the arrow pop-up keys to move the cursor around the loop. The values for both loop axes are shown for every point on the loop.

Select the X at the top of the loop list to exit the cursor.

Changing Loops Type

To change the loop type, in the **Loops** window, select the **Loop Type** pop-up key (only available if the source device delivers three waves), then select

- **Press/Volume** to display Pressure/Volume loops
- **Flow/Volume** to display Volume/Flow loops
- **Press/Flow** to display Pressure/Flow loops.

or, if the source device only delivers two waves,

- 1 In the **Loops** window, select the **Setup Device** pop-up key to enter the setup window for the external device.
- 2 Select **Wave 1** and select pressure, flow, or volume waves as required. Repeat for **Wave 2**.

Setting Up Source Device

The source device for the loops is indicated in the **Loops** window title.

- Select the **Setup Device** pop-up key to view the settings of the current source device.

If the source device is changed, all reference loops from a previous device are cleared from the reference list when the first loop from the new source device is captured. Reconnecting the previous device recalls its reference list.

Documenting Loops

- 1 In the **Loops** window, select the pop-up key **Print Loop**
- 2 From the list of available loops, select an individual loop, or select **Print All** to print a report of all

For each loop, the report prints

- the currently-displayed loop, with the loop capture timestamp
- up to six realtime numerics provided by the loop source device
- SpO₂, etCO₂, PO₂, and PCO₂ numerics from the patient monitor, if available.

Laboratory Data

Laboratory data can be entered manually at the Information Center or at the monitor. For details on manual entry at the monitor, see “Entering Measurements Manually” on page 46. Selected laboratory data can be integrated on the monitor - values are then stored in the database and included in trends and reports and can be displayed as a numeric on the main screen. Which data can be stored and used on the monitor in this way is selected in Configuration Mode.

Viewing Received Data

When new data has been received from the Information Center a **New Lab Data received. Check Lab Results Window.** message will appear with the arrival time. To view the data, select **Main Setup** then select **Lab Results** or the **Lab Results** SmartKey.

The **Lab Results** window shows the most recent set of data received. The data is grouped into categories:

- **Blood Gases**
- **Electrolytes**
- **Hematology**
- **Metabolites**
- **Chemistry**
- **Enzymes/Markers**
- **Coagulation**
- **Urine Diagnostics**

If no results are available for a particular category, that category will not be shown. Values which were entered manually at the Information Center will be marked with an asterisk (*).

Using Batteries

- MX400/** The Lithium Ion batteries used in your monitor store a large amount of energy in a small package. This allows reliable battery-operated monitoring but also requires care in use and handling of the batteries.
- MX450/**
- MX500/** Follow the instructions in this chapter and refer for further details to the Service Guide.
- MX550** One Philips M4605A rechargeable Lithium Ion battery must be inserted into the battery compartment on the right side of the monitor to use the monitor with battery power.



1 Battery compartment

You can switch between battery-powered and mains-powered (AC) operation without interrupting monitoring.

The battery recharges automatically when the monitor is connected to mains power.

Battery Power Indicators

The battery LED and battery status information on the Main Screen, in combination with INOP messages and prompts, help you keep track of the battery power status. The indicators always show the remaining capacity in relation to the battery's actual maximum capacity, which may lessen as the battery ages. You can see the actual capacity in the **Battery Status** window.

Battery LED

The battery LED on the front panel of the monitor is indicated by a battery symbol.



1 Battery LED

Battery LED Colors	If the monitor is connected to mains power, this means	If the monitor is running on battery power, this means
Green	battery power is > 90%	
Yellow	battery charging (battery power < 90%)	
Red, flashing		less than 10 minutes power remaining
Red, flashes intermittently	battery or charger malfunction	battery malfunction

Battery Status on the Main Screen

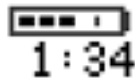

The status of the battery is shown, with the battery power remaining and, when the battery is not charging, an estimate of the monitoring time this represents.

Battery power gauge:



This shows the remaining battery power. It is divided into sections, each representing 20% of the total power. If three sections are filled, as in this example, this indicates that 60% battery power remains. If no battery is detected, a blank battery gauge marked with a flashing red X is displayed. If no data is available from the battery, a question mark is shown in the gauge.

If there are problems or changes in the status of the battery this is indicated by a blank battery gauge containing a symbol. If the symbol is red, this indicates a critical situation.

Battery status indicator		Battery malfunction indicator	
	Alternates with the battery gauge on the Main Screen. Check in the Battery Status window to identify the cause.		The red ! flashes. Critical battery situation or malfunction. Check in the Battery Status window to see which malfunction indicator is displayed, or refer to the INOP, to identify the cause.

Monitoring Time Available: While the monitor is running on battery power, a time is displayed below the battery power gauge. No time is displayed when the monitor is running on external power. This is the estimated monitoring time available with the current battery power. Note that this time fluctuates depending on the system load (the display brightness and how many measurements you carry out).

Battery Status Window

To access the **Battery Status** window and its associated pop-up keys, select the battery status information on the Screen, or select **Main Setup** then **Battery**.

- **Capacity, remaining** tells you how much power is left in the battery.
- **TimeToEmpty** tells you approximately how long you can continue to use the monitor with this battery. Note that this time fluctuates depending on the system load (the display brightness and how many measurements and recordings you carry out).
- **TimeToFull** is shown in place of **TimeToEmpty** if the monitor is connected to mains power, and tells you how much time is left until the battery is charged to 90%. If >10 hrs is shown here, the battery may not charge completely when the monitor is in use. You can use the 865432 Smart Battery Conditioner (previously M8043A) to charge the batteries externally.

Checking Battery Charge

To check the charge status of a battery, refer to the battery power gauge on the screen, or open the **Battery Status** window.

When Battery Lifetime is Expired

When the battery is aged, either after 3 years from manufacturing date or after 500 charge/discharge cycles, it is recommended to replace the battery. To remind you of this, a message will appear in the **Battery Status** window. This message will only be displayed at the appropriate time when the date and time on the monitor is correct.

Replacing a Battery



To replace the battery,

- 1 Press on the battery compartment door and slide it to the right to open it.
- 2 Pull gently on the canvas strap to move the battery towards you, then grasp the battery and pull it out fully.
- 3 Slide the new battery into position, making sure that the battery contacts are facing in the correct direction, as outlined on the inside of the battery compartment door.
- 4 Close the battery compartment door.

Optimizing Battery Performance

The performance of rechargeable batteries may deteriorate over time. Battery maintenance as recommended here can help to slow down this process.

Display Brightness Setting

- 1 In the **Main Setup** menu, select **User Interface, Brightness**, then **Optimum**. This selects a level of brightness suitable for most monitoring locations that uses less battery power than brighter settings.
- 2 Ensure that the current level of brightness is suitable for your monitoring location.

Charging a Battery

A battery can be charged in monitors used to monitor patients. Charging is quicker in monitors which are switched off. You can also use the 865432 Smart Battery Conditioner (previously M8043A) to charge batteries.

- 1 Insert the battery into a monitor connected to mains power. The battery LED will light yellow to indicate that charging is in process (it can take up to three minutes before charging begins).
- 2 Charge the battery until it is full, the battery LED is green, and the battery power gauge is filled.

In certain situations, where many measurements are in use plus the recorder, the load on the monitor may be so high that the batteries will not charge. In this case you must use the 865432 Smart Battery Conditioner (previously M8043A Smart Battery Conditioner) to charge the battery.

Conditioning a Battery

You must condition a battery when its "battery requires maintenance" symbol shows on the Screen. Do not interrupt the charge or discharge cycle during conditioning. You can condition a battery in a monitor.

CAUTION

Do not use a monitor that is being used to condition batteries to monitor patients. The monitor switches off automatically when there is no battery power left.

It is, however, preferable to use the 865432 Smart Battery Conditioner (previously M8043A) for external battery conditioning. The Smart Battery Conditioner automatically performs the correct charge or conditioning process and evaluates the capacity when fully charged. For details please see the Instructions for Use for the Smart Battery Conditioner. Do not use any other battery chargers or conditioners.

To condition a battery using a monitor,

- 1 Insert the battery into a monitor connected to mains power.
- 2 Switch the monitor power off.
- 3 Charge the battery until it is completely full. Open the **Battery Status** window and check that the **Batt fully charged** message is displayed.
- 4 Disconnect the monitor from mains power, and let the monitor run until there is no battery power left and the monitor switches itself off.
- 5 Reconnect the monitor to mains power and charge the battery until it is full for use or charge to 50% for storage.

Storing a Battery

WARNING

Remove the battery from the monitor when it is not used for a longer period of time, to avoid potential damage caused by battery leakage.

Batteries should be charged to a maximum of 50% for storage.

The battery will discharge over time if it is stored inside the monitor without AC power connection. The reported values for "remaining capacity" and "runtime" will become less accurate when the battery is stored in this way for a longer period of time (that is, several weeks).

Disposing of Used Batteries

Dispose of used batteries promptly and in an environmentally-responsible manner. Discharge the batteries and insulate the terminals with tape before disposal. Do not dispose of the battery in normal waste containers. Consult your hospital administrator to find out about local arrangements.

Battery Safety Information

WARNING

- Use only Philips batteries specified in the chapter on "Accessories". Use of a different battery may present a risk of fire or explosion.
 - Do not open batteries, heat above 60°C (140°F), incinerate batteries, or cause them to short circuit. They may ignite, explode, leak or heat up, causing personal injury.
 - If battery leakage should occur, use caution in removing the battery. Avoid contact with skin. Refer to qualified service personnel.
 - Do not expose batteries to liquids.
 - Do not crush, drop or puncture batteries - mechanical abuse can lead to internal damage and internal short circuits which may not be visible externally.
 - If a battery has been dropped or banged against a hard surface, whether damage is visible externally or not:
 - discontinue use
 - dispose of the battery in accordance with the disposal instructions above.
 - Keep batteries out of the reach of children
 - Keep batteries in their original package until you are ready to use them.
-

Care and Cleaning

Use only the Philips-approved substances and methods listed in this chapter to clean or disinfect your equipment. Warranty does not cover damage caused by using unapproved substances or methods.

Philips makes no claims regarding the efficacy of the listed chemicals or methods as a means for controlling infection. Consult your hospital's Infection Control Officer or Epidemiologist. For comprehensive details on cleaning agents and their efficacy refer to "Guidelines for Prevention of Transmission of Human Immunodeficiency Virus and Hepatitis B Virus to Health Care and Public-Safety Workers" issued by the U.S. Department of Health and Human Services, Public Health Service, Centers for Disease Control, Atlanta, Georgia, February 1989. See also any local policies that apply within your hospital, and country.

General Points

Keep your monitor, modules, Multi-Measurement Module, MMS extensions, Flexible Module Rack, cables and accessories free of dust and dirt.

After cleaning and disinfection, check the equipment carefully. Do not use if you see signs of deterioration or damage. If you need to return any equipment to Philips, decontaminate it first.

Observe the following general precautions:

- Always dilute cleaning agents according to the manufacturer's instructions or use lowest possible concentration.
- Do not allow liquid to enter the case.
- Do not immerse any part of the equipment or any accessories in liquid.
- Do not pour liquid onto the system.
- Never use abrasive material (such as steel wool or silver polish).
- Never use bleach except in an approved product listed in this chapter.

WARNING

If you spill liquid on the equipment, battery, or accessories, or they are accidentally immersed in liquid, contact your service personnel or Philips service engineer. Do not operate the equipment before it has been tested and approved for further use.

The general care and cleaning information given here meets the requirements of Covidien llc for their BIS measurement devices.

Cleaning the Equipment

Clean with a lint-free cloth, moistened with warm water (40°C/104°F maximum) and soap, a diluted non-caustic detergent, tenside, ammonia- or alcohol-based cleaning agent. Do not use strong solvents such as acetone or trichloroethylene.

Take extra care when cleaning the screen of the monitor because it is more sensitive to rough cleaning methods than the housing. Do not permit any liquid to enter the monitor case and avoid pouring it on the monitor while cleaning. Do not allow water or cleaning solution to enter the measurement connectors. Wipe around, not over, connector sockets.

CAUTION

To clean the touch-enabled display, disable the touch operation by switching off the monitor during the cleaning procedure, or by selecting and holding the **Main Screen** key until the padlock symbol appears on it, indicating that touch operation is disabled. Select and hold again to re-enable touch operation.

Unplug a mouse, keyboard or other connected device before cleaning it.

Disinfecting the Equipment

CAUTION

Solutions: Do not mix disinfecting solutions (such as bleach and ammonia) as hazardous gases may result.

Clean equipment before disinfecting. Recommended types of disinfecting agents are:

Product Name	Product Type	Ingredients
Isopropanol	liquid	Isopropanol 80%
Bacillol [®] AF	liquid, spray	100 g concentrate contains: Propan-1-ol 45.0 g; Propan-2-ol 25.0 g; Ethanol 4.7 g
Bacillol [®] 25	liquid	Ethanol 100 mg/g Propan-2-ol (= 2-Propanol) 90 mg/g; Propan-1-ol (= 1-Propanol) 60 mg/g
Meliseptol [®]	spray	50% 1-Propanol
Accel TB RTU	liquid	0.5% accelerated hydrogen peroxide
Oxivir [®] Tb Cleaner Disinfectant	spray	0.5% accelerated hydrogen peroxide
Oxivir [®] Tb Wipes	wipes	0.5% accelerated hydrogen peroxide
Carpe Diem ^{TM/MC} Tb Ready-to-Use General Virucide, Bactericide, Tuberculocide, Fungicide, Sanitizer	spray	0.5% accelerated hydrogen peroxide

Product Name	Product Type	Ingredients
Carpe Diem ^{TM/MC} Tb Wipes	wipes	0.5% accelerated hydrogen peroxide
Super Sani-Cloth Germicidal Disposable Wipes	wipes	isopropanol 55% quaternary ammonium chlorides 0.5%
SANI-CLOTH [®] PLUS Germicidal Disposable Wipes	wipes	isopropanol 15% quaternary ammonium chlorides 0.25%
SANI-CLOTH [®] HB Germicidal Germicidal Disposable Wipes	wipes	isopropanol < 0.15% quaternary ammonium chlorides 0.14%
Clorox [®] Hydrogen Peroxide Disinfecting Wipes ¹	wipes	1 - 5% hydrogen peroxide 1 - 5% benzyl alcohol

¹ Do not use Clorox[®] Hydrogen Peroxide Disinfecting Wipes for snap fits (for example the battery cover) or hinges. Remove all residues with water after the residence time. For repeated or prolonged use, wear rubber or nitrile gloves to protect your hands.

Sterilizing the Equipment

Sterilization is not allowed for this monitor, related products, accessories or supplies unless otherwise indicated in the Instructions for Use that accompany the accessories and supplies.

Cleaning, Sterilizing and Disinfecting Monitoring Accessories

To clean, disinfect and sterilize reusable transducers, sensors, cables, leads, and so forth, refer to the instructions delivered with the accessory. If no instructions are delivered with the accessory, the instructions given in this chapter for cleaning, disinfecting and sterilizing the monitor are applicable.

Cleaning the SO2 Optical Module

The outside of the optical module can be cleaned as described under “Cleaning the Equipment” on page 412. The compartment with the fiber-optic connection can only be cleaned with a dry cloth. Do not introduce any moisture into this compartment.

Cleaning the Recorder Printhead (M1116B only)

If you run recordings at low speed (1 or 2cm/min) for extended periods, deposits of paper debris may collect on the print head making recordings unevenly fainter in horizontal stripes.

- 1 Remove the recorder.
- 2 Open the recorder door and un-thread the paper from behind the rubber roller.
- 3 Tear off or roll up the excess paper into the roll chamber to get it out of your way.

- 4 Thread the cloth cleaning strip instead of paper around the rubber roller until approximately two inches of the strip come out from the top of the roller.

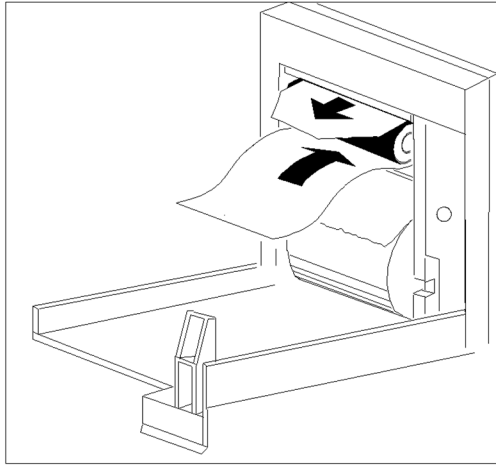

- 5 Close the recorder door, aligning both ends of the strip over the top of the door.
- 6 Holding the top end of the cleaning strip between your thumb and forefinger, pull the strip through and out of the recorder.
- 7 Open the door and ensure that the paper cavity is dust-free. Re-thread the paper and replace the recorder.

Cleaning Batteries and the Battery Compartment

MX400/450/500/550 Wipe with a lint-free cloth, moistened with warm water (40°C/104°F maximum) and soap. Do not use strong solvents. Do not soak the battery.

Maintenance and Troubleshooting

WARNING

Schedule: Failure on the part of the responsible individual hospital or institution employing the use of this equipment to implement a satisfactory maintenance schedule may cause undue equipment failure and possible health hazards.

Contact: If you discover a problem with any of the equipment, contact your service personnel, Philips, or your authorized supplier.

Inspecting the Equipment and Accessories

You should perform a visual inspection before every use, and in accordance with your hospital's policy. With the monitor switched off:

- 1 Examine unit exteriors for cleanliness and general physical condition. Make sure that the housings are not cracked or broken, that everything is present, that there are no spilled liquids and that there are no signs of abuse.
- 2 Inspect all accessories (cables, transducers, sensors and so forth). If any show signs of damage, do not use.
- 3 Switch the monitor on and make sure the backlight is bright enough. Check that screen is at its full brightness. If the brightness is not adequate, contact your service personnel or your supplier.
- 4 If the MMS and MMS Extensions are mounted on the monitor, make sure that they are locked into place and do not slide out without releasing the locking mechanism.

WARNING

Electrical Shock Hazard: Do not open the monitor or measurement device. Contact with exposed electrical components may cause electrical shock. Always turn off and remove power before cleaning the sensor, monitor or measurement device. Do not use a damaged sensor or one with exposed electrical contacts. Refer servicing to qualified service personnel.

Inspecting the Cables and Cords

- 1 Examine all system cables, the power plug and cord for damage. Make sure that the prongs of the plug do not move in the casing. If damaged, replace it with an appropriate Philips power cord.
- 2 Inspect the Measurement Link cable and ensure that it makes good connection with the MMS and the FMS. Make sure that there are no breaks in the insulation.
- 3 Inspect the cable connecting the MMS to the monitor. Make sure the connectors are properly engaged.
- 4 Inspect the patient cables, leads and their strain reliefs for general condition. Make sure there are no breaks in the insulation. Make sure that the connectors are properly engaged at each end to prevent rotation or other strain.
- 5 Apply the transducer or electrodes to the patient, and with the monitor switched on, flex the patient cables near each end to make sure that there are no intermittent faults.

Maintenance Task and Test Schedule

The following tasks are for Philips-qualified service professionals only. All maintenance tasks and performance tests are documented in detail in the service documentation supplied on the monitor documentation DVD.

Ensure that these tasks are carried out as indicated by the monitor's maintenance schedule, or as specified by local laws. Contact a Philips-qualified service provider if your monitor needs a safety or performance test. Clean and disinfect equipment to decontaminate it before testing or maintaining it.

Maintenance and Test Schedule	Frequency
Monitor Tests	
Safety checks. Selected tests on the basis of IEC 60601-1	At least once every two years, or as needed, after any repairs where the power supply is removed or replaced, or if the monitor has been dropped.
Monitor Maintenance	
Check ECG synchronization of the monitor and defibrillator (only if hospital protocol requires use of monitor during defibrillation)	At least once every two years, or as needed.
<i>MX600/700/800 only</i> Replace backlight (integrated displays only)	25,000 - 30,000 hours (about three years) of continuous usage, or as needed.
Multi-measurement Module and Module Tests	
Performance assurance for all measurements not listed below.	At least once every two years, or if you suspect the measurement values are incorrect.
Multi-measurement Module and Module Maintenance	
NBP calibration	At least once every two years, or as specified by local laws.
Microstream CO ₂ calibration and performance test	At least once a year or after 4000 operating hours.

Maintenance and Test Schedule	Frequency
Mainstream and sidestream CO ₂ calibration and sidestream flow check (M3014A)	At least once a year, or if you suspect the measurement values are incorrect.

Troubleshooting

If you suspect a problem with an individual measurement, read the Instructions for Use and double-check that you have set up the measurement correctly.

If you suspect an intermittent, system-wide problem call your service personnel. You may be asked for information from the status log. To view the status log,

- 1 In the **Main Setup** menu, select **Revisions**.
- 2 Select the pop-up key corresponding to the status log you want to consult, for example, for the MMS or the monitor.
- 3 View the status log by selecting **Status Log** from the **Monitor Revision** window.

Returning Equipment for Repair

Before returning equipment for repair:

- disinfect and decontaminate the equipment appropriately.
- ensure that all patient data has been removed (i.e. that no patient is admitted).

Disposing of the Monitor

WARNING

To avoid contaminating or infecting personnel, the environment or other equipment, make sure you disinfect and decontaminate the monitor appropriately before disposing of it in accordance with your country's laws for equipment containing electrical and electronic parts. For disposal of parts and accessories such as thermometers, where not otherwise specified, follow local regulations regarding disposal of hospital waste.

You can disassemble the monitor, MMS, FMS and modules as described in the Service Guide.

You will find detailed disposal information on the following web page:

<http://www.healthcare.philips.com/main/about/Sustainability/Recycling/pm.wpd>

The Recycling Passports located there contain information on the material content of the equipment, including potentially dangerous materials which must be removed before recycling (for example, batteries and parts containing mercury or magnesium).



Do not dispose of electrical and electronic equipment as unsorted municipal waste. Collect it separately, so that it can be safely and properly reused, treated, recycled, or recovered.

Disposing of Empty Calibration Gas Cylinders

- 1 Empty the cylinder completely by pushing in the pin of the regulator valve or by pulling out the pin of the fill valve using a tire valve stem wrench or a pair of needle nose pliers.
- 2 When the cylinder is empty, either remove the valve stem from the fill (or regulator) hole, or drill a hole in the cylinder.
- 3 Write "Empty" on the cylinder and dispose of it appropriately for scrap metal.

WARNING

Ensure that the cylinder is completely empty before trying to remove the valve stem or drill a hole in the cylinder.

Accessories

This chapter lists Philips-approved accessories for use with patient monitors as described in this document. You can order parts and accessories from Philips supplies at www.medical.philips.com or consult your local Philips representative for details. Some accessories may not be available in all countries.

WARNING

Reuse: Never reuse disposable transducers, sensors, accessories and so forth that are intended for single use, or single patient use only. Reuse may compromise device functionality and system performance and cause a potential hazard.

Philips' approval: Use only Philips-approved accessories. Using non-Philips-approved accessories may compromise device functionality and system performance and cause a potential hazard.

Packaging: Do not use a sterilized accessory if its packaging is damaged.

ECG/Resp Accessories



This symbol indicates that the cables and accessories are designed to have special protection against electric shocks (particularly regarding allowable leakage currents), and are defibrillator proof.

The following cables may not all be available in all countries. Please check availability with your local Philips supplier.

Recommended Cables

Trunk Cables

For use with:	Part No.	Length
3-Electrode Cable Set	M1669A	2.7 m
3-Electrode Cable Set, OR	989803170171	2.7 m
5-Electrode Cable Set	M1668A	2.7 m
5-Electrode Cable Set, OR	989803170181	2.7 m
6-Electrode Cable Set	M1667A	2.7 m

39 Accessories

For use with:	Part No.	Length
10-Electrode Cable set (5+5)	M1663A	2.7 m
10-Electrode Cable set (6+4)	M1665A	2.7 m

3-Electrode Cable Sets

Description	Length	AAMI Part No.	IEC Part No.
OR Grabber shielded	1.0 m	M1675A	M1678A
ICU Grabber shielded	1.0 m	M1671A	M1672A
ICU snap shielded	1.0 m	M1673A	M1674A
ICU Clip non-shielded	0.45 m	M1622A	--
ICU Clip non-shielded	0.7 m	M1624A	M1626A

Single Patient 3-Electrode Cable Sets

Description	Length	AAMI Part No.	IEC Part No.
ICU Grabber shielded	1.0 m	989803173121	989803174201
ICU Grabber shielded	0.84 m	989803173141	-

5-Electrode Cable Sets

Description	Length	AAMI Part No.	IEC Part No.
OR Grabber shielded	1.0 m/1.6 m	M1973A	M1974A
ICU Grabber shielded	1.0 m/1.6 m	M1968A	M1971A
ICU Snap shielded	1.0 m/1.6 m	M1644A	M1645A
ICU Miniclip non-shielded	0.7 m/1.3 m	M1647A	M1648A

Single Patient 5-Electrode Cable Sets

Description	Length	AAMI Part No.	IEC Part No.
ICU Grabber shielded	1.0 m	989803173131	989803174211
ICU Grabber shielded	0.85 m	989803173151	-

6-Electrode Cable Sets

Description	Length	AAMI Part No.	IEC Part No.
OR Grabber	1.0 m/1.6 m	M1684A	M1685A
ICU Grabber	1.0 m/1.6 m	M1680A	M1681A
ICU Snap	1.0 m/1.6 m	M1682A	M1683A

10-Electrode (5+5) Cable Sets

Description	Length	AAMI Part No.	IEC Part No.
ICU Grabber, chest, shielded	1.0 m	M1976A	M1978A
ICU Snap, chest, shielded	1.0 m	M1602A	M1604A
OR Grabber, chest, shielded	1.0 m	M1979A	M1984A
For Limb Leads see 5-electrode cable sets			

10-Electrode (6+4) Cable Sets

Description	Length	AAMI Part No.	IEC Part No.
ICU Grabber, chest, shielded	1.0 m	M1532A	M1533A
ICU Snap, chest, shielded	1.0 m	M1537A	M1538A
OR Grabber, chest, shielded	1.0 m	M1557A	M1558A
For Limb Leads see 6-electrode cable sets			

One-piece Cables

Description	Length	AAMI Part No.	IEC Part No.
3-lead Grabber, ICU	1.0 m	989803143181	989803143171
5-lead Grabber, ICU	1.0 m	989803143201	989803143191

Radio-translucent Cables

Pack of five single wires, radio-translucent, 0.9 m, M1649A

Set Combiners and Organizers

Description	Part No.	
Set combiner	3-electrode	M1501A
	5-electrode	M1502A
Set organizer for shielded leadsets - grabber and snap	3-electrode	M1503A
	4-electrode	M1664A
	5-electrode	M1504A
	6-electrode	M1679A
Set organizer for non-shielded lead sets - miniclip	3-electrode	M1636A
	5-electrode	M1638A
Bedsheet clip	M1509A	
Replacement red cover for trunk cable (for 5-electrode cable sets)	989808148861	

Supported Cables

Trunk Cables

Length	3-Electrode Cable Set		5-Electrode Cable Set	
	AAMI Part No.	IEC Part No.	AAMI Part No.	IEC Part No.
0.9 m	M1540C	M1550C	M1560C	M1570C
2.7 m	M1500A	M1510A	M1520A	M1530A

3-Electrode Cable Sets

Description	Length	AAMI Part No.	IEC Part No.
OR	1.0 m	M1601A	M1611A
ICU Grabber shielded	1.0 m	M1603A	M1613A
ICU snap shielded	1.0 m	M1605A	M1615A
ICU Clip non-shielded	0.45 m	M1608A	M1618A
ICU Clip non-shielded	0.7 m	M1609A	M1619A

5-Electrode Cable Sets

Description	Length	AAMI Part No.	IEC Part No.
OR Grabber shielded	1.0 m/1.6 m	M1621A	M1631A
ICU Grabber shielded	1.0 m/1.6 m	M1623A	M1633A
ICU Snap shielded	1.0 m/1.6 m	M1625A	M1635A
ICU Clip non-shielded	0.7 m/1.3 m	M1629A	M1639A

3-Electrode One Piece Cables

Description	Length	AAMI Part No.	IEC Part No.
OR Grabber	1.9 m	M1970A	M1980A
ICU Snap	1.9 m	M1972A	M1981A

5-Electrode One Piece Cables

Description	Length	AAMI Part No.	IEC Part No.
OR Grabber	2.5 m	M1975A	M1985A
ICU Snap	2.5 m	M1977A	M1986A

Set Combiners and Organizers

Description	Part No.	
Set combiner	3-electrode	M1501A
	5-electrode	M1502A
Set organizer	Shielded 3-electrode	M1503A
	Shielded 5-electrode	M1504A
Bedsheet clip	M1509A	

NBP Accessories



These cuffs and tubings are designed to have special protection against electric shocks (particularly regarding allowable leakage currents), and are defibrillator proof. You can use them during electrosurgery.

Adult/Pediatric Reusable Comfort Care Cuffs

Patient Category	Limb Circumference	Part No.	Tubing
Adult (Thigh)	42 to 54 cm	M1576A	M1598B (1.5 m) or M1599B (3 m)
Large Adult	34 to 43 cm	M1575A	
Adult	27 to 35 cm	M1574A	
Small Adult	20.5 to 28 cm	M1573A	
Pediatric	14 to 21.5 cm	M1572A	
Infant	10 to 15 cm	M1571A	

Adult/Pediatric Reusable Comfort Care Cuff Kits

Cuff Kits	Part No.
Infant, pediatric, small adult, adult	M1577A
Small adult, adult, large adult, thigh	M1578A
Infant, pediatric, small adult, adult, large adult, thigh	M1579A

Adult/Pediatric Reusable Easy Care Cuffs

Patient Category	Limb Circumference	Part No. (Pack of five)	Tubing
Adult Thigh	44 - 56 cm	M4559B (M4559B5)	M1598B (1.5 m) or M1599B (3 m)
Large Adult X-Long	35 - 45 cm	M4558B (M4558B5)	
Large Adult	35 - 45 cm	M4557B (M4557B5)	
Adult X-Long	27.5 - 36 cm	M4556B (M4556B5)	
Adult	27.5 - 36 cm	M4555B (M4555B5)	
Small Adult	20.5 - 28.5 cm	M4554B (M4554B5)	
Pediatric	14 - 21.5 cm	M4553B (M4553B5)	
Infant	10 - 15 cm	M4552B (M4552B5)	

Adult/Pediatric Reusable Easy Care Cuff Kits

Cuff Kits	Part No.
Assortment pack of one small adult, one adult, one large adult and one thigh cuff	864288
Assortment pack of one infant, one pediatric, one small adult and one adult cuff	864289
Assortment pack of one infant, one pediatric, one small adult, one adult, one large adult and one thigh cuff	864290
Assortment pack of one small adult, one adult, one adult X-long, one large adult, one large adult X-long and one thigh cuff	864291

Adult/Pediatric Multi Care Cuffs

Patient Category	Limb Circumference	Part No.	Tubing
Adult Thigh	42.0 - 54.0 cm	989803183371	M1598B (1.5 m) or M1599B (3 m)
Large Adult	34.0 - 43.0 cm	989803183361	
Large Adult X-Long	27.0 - 35.0 cm	989803183351	
Adult	27.0 - 35.0 cm	989803183341	
Small Adult	20.5 - 28.0 cm	989803183331	
Pediatric	14.0 - 21.5 cm	989803183321	
Infant	10.0 - 15.0 cm	989803183311	

Adult/Pediatric Single Patient, Gentle Care Cuffs

Patient Category	Limb Circumference	Part No.	Tubing
Adult (Thigh)	44 - 56 cm	M4579B	M1598B (1.5 m) or M1599B (3 m)
Large Adult X-Long	35 - 45 cm	M4578B	
Large Adult	35 - 45 cm	M4577B	
Adult X-Long	27.5 - 36 cm	M4576B	
Adult	27.5 - 36 cm	M4575B	
Small Adult	20.5 - 28.5 cm	M4574B	
Pediatric	14.0 - 21.5 cm	M4573B	
Infant	10 - 15 cm	M4572B	

Adult/Pediatric Single Care Cuffs

Patient Category	Limb Circumference	Part No.	Tubing
Large Adult	35.0 - 45.0 cm	989803182321	M1598B or M1599B
Adult X-Long	27.5 - 36.0 cm	989803182311	
Adult	27.5 - 36.0 cm	989803182301	
Small Adult	20.5 - 28.5 cm	989803182291	
Pediatric	14.0 - 21.5 cm	989803182281	

Adult/Pediatric Value Care Cuffs

Patient Category	Limb Circumference	Part No.	Tubing
Large Adult	34.0 - 43.0 cm	989803160861	M1598B (1.5 m) or M1599B (3 m)
Large Adult X-Long	27.0 - 35.0 cm	989803160851	
Adult	27.0 - 35.0 cm	989803160841	
Small Adult	20.5 - 28.0 cm	989803160831	
Pediatric	14.0 - 21.5 cm	989803160821	
Infant	10.0 - 15.0 cm	989803160811	

Neonatal/Infant Single Patient Cuffs

Cuffs	Limb Circumference	Part No. A - Luer connector B - ISO 80369-1 compliant connector	Tubing
Size 1	3.1 to 5.7 cm	M1866A/B	For A-version cuffs: M1596B (1.5 m) or M1597B (3 m) For B-version cuffs: M1596C (1.5 m) or M1597C (3 m)
Size 2	4.3 to 8.0 cm	M1868A/B	
Size 3	5.8 to 10.9 cm	M1870A/B	
Size 4	7.1 to 13.1 cm	M1872A/B	
Size 5 (Infant)	10 to 15 cm	M1873B	

Neonatal/Infant Single Patient, Soft Cuffs

Cuffs	Limb Circumference	Part No.	Tubing
Size 1	3.1 to 5.7 cm	M1866S	M1596C (1.5 m) or M1597C (3 m)
Size 2	4.3 to 8.0 cm	M1868S	
Size 3	5.8 to 10.9 cm	M1870S	
Size 4	7.1 to 13.1 cm	M1872S	
Size 5 (Infant)	10 to 15 cm	M1873S	

Neonatal/Infant Cuff Kits

Cuff Kits	Part No.
Standard, Single Patient, Luer connector: 10 x M1866A, 10 x M1868A, 10 x M1872A, and 20 x M1870A	M1820-60020
Standard, Single Patient, ISO 80369-1 compliant connector: 5 x M1866B, 10 x M1868B, 20 x M1870B, 10 x M1872B, and 5 x M1873B	989803167541
Soft, Single Patient, ISO 80369-1 compliant connector: 5 x M1866S, 10 x M1868S, 20 x M1870S, 10 x M1872S, 5 x M1873S	989803167551

Invasive Pressure Accessories



These transducers and accessories are designed to have special protection against electric shocks (particularly regarding allowable leakage currents), and are defibrillator proof.

If you are using the M3012A Hemodynamic MMS Extension, and you want to measure temperature and invasive pressure at the same time, we recommend that you use the pressure transducer CPJ840J6, with a round module connector piece, and not a transducer with a square connector. Pressure transducers with square connectors may make it difficult to connect the adjacent Temperature connector at the same time.

Transducer, accessories, sensor kits	Part No.
Reusable pressure transducer 5 μ V/V/mmHg sensitivity	CPJ840J6
Sterile disposable pressure domes for CPJ840J6 (pack of 50)	CPJ84022
Transducer holder for CPJ840J6 (pack of 4)	CPJ84046
IV pole mount for CPJ840J6	CPJ84447
Monitoring Line Set for CPJ840J6	CPJ84026
Single channel disposable sensor kit (20) - (EU/EFTA only)	M1567A
Dual channel disposable sensor kit (20) (EU/EFTA only)	M1568A
Transducer holder for M1567/8A (EU/EFTA only)	M2271A
IV pole mount for M1567/8A (EU/EFTA only)	M2272C
Adapter cable for disposable sensor kit 3.0 m for M1567/8A	M1634A
Pressure transducer kits	
PiCCO monitoring kit, 30 cm pressure line, includes PV4046 injectate temperature sensor housing for M1646A	PV8103
PiCCO monitoring kit, 150 cm pressure line, includes PV4046 injectate temperature sensor housing for M1646A	PV8115
PiCCO monitoring kit, 150 cm pressure line, includes PV4046 injectate temperature sensor housing for M1646A and central venous pressure line	PV8115CVP
PULSION Pressure Interface Cable for disposable pressure transducer	PMK 206

Transpac 4 Disposable Pressure Transducer Pressure Monitoring Kits

Transducer Pressure Monitoring Kits with SafeSet Blood Sampling/Conservation System

Description	Length	Quantity (per box)	Part No.
Single DPT TP4 with SafeSet, 2 Cannula Sampling Ports, In-line Reservoir	213 cm (84 in)	20	989803179741
Single DPT TP4 with SafeSet, 2 Luer Sampling Ports, In-line Reservoir	213 cm (84 in)	20	989803179751
Single DPT TP4 with SafeSet, 1 Cannula Sampling Port, In-line Reservoir	152 cm (60 in)	20	989803179761
Single DPT TP4 with SafeSet, 2 Cannula Sampling Ports, In-line Reservoir	152 cm (60 in)	20	989803179781
Single DPT TP4 with SafeSet, 2 Luer Sampling Ports, In-line Reservoir	152 cm (60 in)	20	989803179791
Single DPT TP4 with SafeSet, Patient Mount, 1 Cannula Sampling Port, In-line Reservoir	61 cm (24 in)	20	989803179861
Dual DPT TP4 with SafeSet, (Clear/Blue dash tubing) 2 Cannula Sampling Ports, In-line Reservoir	213 cm (84 in)	10	989803179801
Dual DPT TP4 with SafeSet, (Clear/Blue dash tubing) 2 Luer Sampling Ports, In-line Reservoir	213 cm (84 in)	10	989803179811

39 Accessories

Description	Length	Quantity (per box)	Part No.
Triple DPT TP4 with SafeSet, 2 Cannula Sampling Ports, In-line Reservoir	213 cm (84 in)	10	989803179821
Triple DPT TP4 with SafeSet, 2 Luer Sampling Ports, In-line Reservoir	213 cm (84 in)	10	989803179831

Transpac and SafeSet are trademarks of ICU Medical, Inc.

Safeset Blood Sampling/Conservation System

Description	Length	Quantity (per box)	Part No.
SafeSet Kit with tubing, 1 In-line Cannula Sampling Port and 10 ml In-line Reservoir	152 cm (60 in)	20	989803180851
SafeSet Kit with tubing, 2 In-line Cannula Sampling Ports and 10 ml In-line Reservoir	213 cm (84 in)	20	989803179891

(Transducer not contained in kit)

Transpac 4 Disposable Pressure Transducer Pressure Monitoring Kits

Description	Stopcocks	Primary Tubing Length	Extension Tubing length	Flush Device	Drip Chamber	Quantity (per box)	Part No.
Single DPT TP4, (152 cm, 60 in) Red dash tubing	Two 3-way	122 cm (48 in)	31 cm (12 in)	3 ml/hr, Squeeze	Macrodrrip	20	989803177901
Dual DPT TP4, (183 cm, 72 in) Red/Blue dash tubing	Four 3-way	152 cm (60 in)	31 cm (12 in)	Two 3 ml/hr, Squeeze	Macrodrrip	10	989803177911
Single DPT TP4, (213 cm, 84 in) Red dash tubing	Two 3-way	183 cm (72 in)	31 cm (12 in)	3 ml/hr, Squeeze	Macrodrrip	20	989803179721
Triple DPT TP4, (152 cm, 60 in)	Six 3-way	122 cm (48 in)	31 cm (12 in)	3 ml/hr, Squeeze	Macrodrrip	10	989803179731
Single DPT TP4, (183 cm, 72 in) Red dash tubing	Two 3-way	152 cm (60 in)	31 cm (12 in)	3 ml/hr, Squeeze	Macrodrrip	20	989803179771
Single DPT TP4, (23 cm, 9 in) Patient Mount	One 3-way	23 cm (9 in)		3 ml/hr, Squeeze	Macrodrrip	20	989803179871
Single DPT TP4, (61 cm, 24 in) Compartmental Pressure	One 4-way One 3-way	61 cm (24 in)		No flush device		20	989803181141
Single DPT TP4, (152 cm, 60 in), Premium Stripe	Two 3-way	122 cm (48 in)	31 cm (12 in)	3 ml/hr, Squeeze	Macrodrrip	20	989803181211
Single DPT TP4, (183 cm, 72 in), Premium Stripe	Two 3-way	152 cm (60 in)	31 cm (12 in)	3 ml/hr, Squeeze	Macrodrrip	20	989803181221
Single DPT TP4, (213 cm, 84 in), Premium Stripe	Two 3-way	183 cm (72 in)	31 cm (12 in)	3 ml/hr, Squeeze	Macrodrrip	20	989803181231
Dual DPT TP4, (183 cm, 72 in), Premium Stripe	Four 3-way	152 cm (60 in)	31 cm (12 in)	3 ml/hr, Squeeze	Macrodrrip	10	989803181241
Triple DPT TP4, (152 cm, 60 in), Premium Stripe	Six 3-way	122 cm (48 in)	31 cm (12 in)	3 ml/hr, Squeeze	Macrodrrip	10	989803181251

Description	Stopcocks	Primary Tubing Length	Extension Tubing length	Flush Device	Drip Chamber	Quantity (per box)	Part No.
Single Neonatal DPT TP4 (61 cm, 24 in)	Two 3-way	61 cm (24 in)		30 ml/hr Squeeze		20	989803179841
Single Neonatal DPT TP4 (31 cm, 12 in)	Three 3-way	31 cm (12 in)		30 ml/hr Squeeze		20	989803179851
Single Neonatal DPT TP4 (46 cm, 18 in) one in-line Luer sampling port & 10 ml In-line reservoir	Three 3-way	46 cm (18 in)		30 ml/hr Squeeze		20	989803179881

Transpac 4 and Safeset Cables and Accessories

Description	Quantity (per box)	Part No.
Cable for Philips Monitors 3 m (10 ft)	1	989803177921
Cable for Philips Monitors 4.5 m (15 ft)	1	989803179941
Cable for Philips Monitors 4.5 m (15 ft)	20	989803179951
Trifurcated Cable for Philips Monitors 4.5 m (15 ft)	1	989803179961
3-Position Transducer Mount	28	989803177931
Transducer Holder for IV Pole	5	989803177941
Single Transducer Mount	30	989803179911
SafeSet Mounting Bracket	30	989803179901
Safeset Shielded Blunt Cannula	50	989803179921
SafeSet Shielded Blunt Cannula with Blood Tube Holder	25	989803179931

SpO₂ Accessories

This section lists accessories for use with Philips SpO₂ technology. For accessory lists for other SpO₂ technologies, refer to the instructions for use provided with these devices.

Some Nellcor sensors contain natural rubber latex which may cause allergic reactions. See the Instructions for Use supplied with the sensors for more information.

Do not use more than one extension cable with any sensors or adapter cables. Do not use an extension cable with:

- Masimo adapter cables,
- Philips reusable sensors or adapter cables with part numbers ending in -L (indicates "Long" version) or with a cable longer than 2 m.

All listed sensors operate without risk of exceeding 41°C on the skin, if the initial skin temperature does not exceed 35°C.

Make sure that you use only the accessories that are specified for use with this device, otherwise patient injury can result.

Always use the MAXFAST forehead sensor with the foam headband provided by Nellcor.

Option A01 is the Philips FAST-SpO₂ version; Option A02 is the Nellcor OxiMax-compatible version.

The SpO₂ Option A02 may not be available in all countries. Some sensors may not be available in all countries.

Philips Reusable Sensors

Product Number	Description	Compatible with		Comments
		Option A01	Option A02	
M1191A/B	Adult sensor (2 m cable), for patients over 50 kg. Any finger, except thumb.	yes	no	No adapter cable required.
M1191AL/BL	M1191A/B with longer cable (3 m)	yes	no	
M1192A	Small adult, pediatric sensor (1.5 m cable) for patients between 15 kg and 50 kg. Any finger except thumb.	yes	no	
M1193A	Neonatal sensor (1.5 m cable) for patients between 1 kg and 4 kg. Hand or foot.	yes	no	
M1194A	Ear sensor (1.5 m cable) for patients over 40 kg.	yes	no	
M1195A	Infant sensor (1.5 m cable) for patients between 4 kg and 15 kg. Any finger except thumb.	yes	no	
M1196A	Adult clip sensor (3 m cable) for patients over 40 kg. Any finger except thumb.	yes	no	
M1196S	Adult clip sensor (2 m cable) for patients over 40 kg. Any finger except thumb.	yes	no	
M1191T	Adult sensor (0.45 m cable), for patients over 50 kg. Any finger, except thumb.	yes	no	Requires M1943A (1 m) or M1943AL (3 m) adapter cable
M1192T	Small adult, pediatric sensor (0.45 m cable) for patients between 15 kg and 50 kg. Any finger except thumb.	yes	no	
M1193T	Neonatal sensor (0.9 m cable) for patients between 1 kg and 4 kg. Hand or foot.	yes	no	
M1196T	Adult clip sensor (0.9 m cable) for patients over 40 kg. Any finger except thumb.	yes	no	

Philips Disposable Sensors

Product Number	Description	Compatible with		Comments
		Option A01	Option A02	
M1901B ¹	Identical to OxiMax MAXN	yes	yes	Option A01: Use M1943A or M1943AL adapter cable. Option A02: Must use M1943NL adapter cable.
M1902B ¹	Identical to OxiMax MAXI	yes	yes	
M1903B ¹	Identical to OxiMax MAXP	yes	yes	
M1904B ¹	Identical to OxiMax MAXA	yes	yes	
M1131A	Adult/Pediatric finger sensor, 0.45 m cable (patient size > 20 kg)	yes	no	Use M1943A or M1943AL adapter cable.
M1132A	Infant finger or toe sensor, 0.9 m cable (patient size 3 - 10 kg)	yes	no	Use M1943A or M1943AL adapter cable.
M1133A	Adult/Infant/Neonatal, 0.9 m cable Foot or hand for neonates < 3 kg Big toe or thumb for patients between 10 kg and 20 kg Any finger except thumb for patients > 40 kg	yes	no	Use M1943A or M1943AL adapter cable.
M1134A	Adhesive-free, Adult/Infant/Neonatal, 0.9 m cable Foot or hand for neonates < 3 kg Big toe or thumb for patients between 10 kg and 20 kg Any finger except thumb for patients > 40 kg	yes	no	Use M1943A or M1943AL adapter cable.

¹Not available in the USA

Nellcor Sensors

Nellcor sensors must be ordered from Nellcor/Covidien.

Product Number	Description	Compatible with		Comments
		Option A01	Option A02	
OxiMax MAXA	Adult finger sensor (patient size > 30 kg)	yes	yes	Option A01: Use M1943A or M1943AL adapter cable.
OxiMax MAXAL	OxiMax MAXA with long cable	yes	yes	
OxiMax MAXP	Pediatric foot/hand sensor (patient size 10 - 50 kg)	yes	yes	Option A02: Must use M1943NL adapter cable.
OxiMax MAXI	Infant foot/hand sensor (patient size 3 - 20 kg)	yes	yes	
OxiMax MAXN	Adult finger or neonatal foot/hand sensor (patient size > 40 kg or < 3 kg)	yes	yes	

Product Number	Description	Compatible with		Comments
		Option A01	Option A02	
MAXFAST	Forehead sensor (patient size \geq 10 kg)	no	yes	Must use M1943NL adapter cable.
OxiMax MAXR	Adult nasal sensor (patient size $>$ 50 kg)	no	yes	
OxiMax SC-A	Adult SoftCare sensor (patient size $>$ 40 kg)	no	yes	
OxiMax SCNEO-I	Neonatal SoftCare sensor (patient size 1.5 - 5 kg)	no	yes	
OxiMax SC-PR-I	Pre-term infant SoftCare sensor (patient size $<$ 1.5 kg)	no	yes	
Oxisensor II D-25	Adult sensor (patient size $>$ 30 kg)	yes	no	Must use M1943A or M1943AL adapter cable.
Oxisensor II D-20	Pediatric sensor (patient size 10 - 50 kg)	yes	no	
Oxisensor II I-20	Infant sensor (patient size 3 - 20 kg)	yes	no	
Oxisensor II N-25	Neonatal sensor (patient size $<$ 3 kg or $>$ 40 kg)	yes	no	
Oxiciq A	See OxiMax MAXA	yes	yes	Option A01: Use M1943A or M1943AL adapter cable together with OC-3 adapter cable. Option A02: Must use M1943NL adapter cable together with OC-3 adapter cable.
Oxiciq P	See OxiMax MAXP	yes	yes	
Oxiciq I	See OxiMax MAXI	yes	yes	
Oxiciq N	See OxiMax MAXN	yes	yes	
Oxiband OXI-A/N	Adult/neonatal sensor	no	yes	Must use M1943NL adapter cable.
Oxiband OXI-P/I	Pediatric/infant sensor	no	yes	
Durasensor DS100A-1	Adult finger clip sensor (patient size $>$ 40 kg)	no	yes	
Dura-Y D-YS	Y-sensor	no	yes	

Extension Cables and Adapter Cables for Philips and Nellcor Sensors

Product Number	Description	Compatible with		Comments
		Option A01	Option A02	
M1941A	Extension cable (2 m)	yes	no	For use with Philips reusable sensors and M1943A adapter cable.
M1943A	Adapter cable (1.1 m cable)	yes	no	Adapter cable for Philips/Nellcor disposable sensors.
M1943AL	Adapter cable (3 m cable)	yes	no	

Product Number	Description	Compatible with		Comments
		Option A01	Option A02	
M1943NL	OxiMax adapter cable (3 m cable)	no	yes	Adapter cable for Philips disposable/ Nellcor disposable and reusable sensors.
OC-3	Adapter Cable for Oxicliq sensors	yes	yes	Available from Nellcor/Covidien only.

MASIMO LNOP Reusable Sensors

The Philips M3001A/M3002A option A01 and the M1020B option A01 SpO₂ Module use Masimo certified pulse oximetry for reduced noise and low perfusion performance with Masimo Sensors under the Masimo NR&LP protocol available from Masimo.



Product Number	Description	Compatible with		Philips Part Number
		Option A01	Option A02	
LNOP DCI	Adult Finger Sensor (> 30 kg)	yes	no	n/a
LNOP DCIP	Pediatric Finger Sensor (10 - 50 kg)	yes	no	n/a
LNOP YI	Multi-Site Sensor (> 1 kg)	yes	no	n/a
LNOP TC-I	Ear Sensor (> 30 kg)	yes	no	n/a

MASIMO LNCS Reusable Sensors

Product Number	Description	Compatible with		Philips Part Number
		Option A01	Option A02	
LNCS DCI	Adult Finger Sensor (> 30 kg)	yes	no	n/a
LNCS DCIP	Pediatric Finger Sensor (10 - 50 kg)	yes	no	n/a
LNCS YI	Multi-Site Sensor (> 1kg)	yes	no	n/a
LNCS TC-I	Ear Sensor (> 30 kg)	yes	no	n/a

MASIMO LNOP Disposable Adhesive Sensors

Product Number	Description	Compatible with		Philips Part Number
		Option A01	Option A02	
LNOP Adt	Adult Sensor (> 30 kg)	yes	no	n/a
LNOP Amtx	Adult Sensor (> 30 kg)	yes	no	n/a
LNOP Pdt	Pediatric Sensor (10 - 50 kg)	yes	no	n/a

Product Number	Description	Compatible with		Philips Part Number
		Option A01	Option A02	
LNOP Pdtx	Pediatric Sensor (10 - 50 kg)	yes	no	n/a
LNOP Inf-L	Infant Toe Sensor (3 - 20 kg)	yes	no	n/a
LNOP Neo-L	Neonatal Sensor (< 3 kg) or Adult adhesive Sensor (> 40 kg)	yes	no	n/a
LNOP NeoPt-L	Neonatal Pre-Term Sensitive Skin Sensors (< 1 kg)	yes	no	n/a

MASIMO LNCS Disposable Adhesive Sensors

Product Number	Description	Compatible with		Philips Part Number
		Option A01	Option A02	
LNCS Adtx	Adult Finger Sensor, 18 inch/45 cm (> 30 kg)	yes	no	n/a
LNCS Adtx-3	Adult Finger Sensor, 3 feet/90 cm (> 30 kg)	yes	no	n/a
LNCS Pdtx	Pediatric Finger Sensor, 18 inch/45 cm (10 - 50 kg)	yes	no	n/a
LNCS Pdtx-3	Pediatric Finger Sensor, 3 feet/90 cm (10 - 50 kg)	yes	no	n/a
LNCS Inf	Infant Toe Sensor, 18 inch/45 cm (3 - 20 kg)	yes	no	n/a
LNCS Inf-3	Infant Toe Sensor, 3 feet/90 cm (3 - 20 kg)	yes	no	n/a
LNCS Neo	Neonatal Foot Sensor, 18 inch/45 cm (< 3 kg) or Adult Finger Sensor 18 inch/45 cm (> 40 kg)	yes	no	n/a
LNCS Neo-3	Neonatal Foot Sensor, 3 feet/90 cm (< 3 kg) or Adult Finger Sensor, 3 feet/90 cm (> 40 kg)	yes	no	n/a
LNCS NeoPt	Neonatal pre-term sensitive skin Sensor 18 inch/45 cm (< 1 kg)	yes	no	n/a
LNCS NeoPt-3	Neonatal pre-term sensitive skin Sensor 3 feet/90 cm (< 1 kg)	yes	no	n/a

Adapter Cable for MASIMO Sensors

Product Number	Description	Compatible with		Philips Part Number
		Option A01	Option A02	
LNOP MP12	LNOP MP Series Patient Cable (3.6 m) Adapter Cable for Masimo LNOP Sensors	yes	no	451261000761

Product Number	Description	Compatible with		Philips Part Number
		Option A01	Option A02	
LNOP MP10	LNCS MP Series Patient Cable (3.0 m) Adapter Cable for Masimo LNCS Sensors	yes	no	989803148221

Temperature Accessories

Temperature Probes	Part No.	Minimum measurement time for accurate readings
Reusable		
General purpose probe	21075A	90 sec
Small flexible vinyl probe (Infant/Pediatric)	21076A	60 sec
Attachable surface probe	21078A	60 sec
Disposable		
General purpose probe	M1837A	90 sec
Skin probe	21091A	60 sec
Esophageal/Stethoscope Probe (French 12)	21093A	180 sec
Esophageal/Stethoscope Probe (French 18)	21094A	210 sec
Esophageal/Stethoscope Probe (French 24)	21095A	310 sec
Esophageal/Rectal Probe (French 12)	21090A	90 sec
Foley Catheter Probe (12 French)	M2255A	180 sec
Foley Catheter Probe (16 French)	21096A	180 sec
Foley Catheter Probe (18 French)	21097A	180 sec
Adapter cable 1.5 m	21082B	--
Adapter cable 3.0 m	21082A	--

Temperature Probes	Part No.	Response Time per ISO 80601-2-56
InnerSense Esophageal Temperature /Feeding Tube, purple (5 French)	989803183631	< 150 seconds
InnerSense Esophageal Temperature /Feeding Tube, purple (6.5 French)	989803183641	
InnerSense Esophageal Temperature /Feeding Tube, purple (8 French)	989803183651	
InnerSense Esophageal Temperature /Feeding Tube, orange (5 French)	989803183561	
InnerSense Esophageal Temperature /Feeding Tube, orange (6.5 French)	989803183571	
InnerSense Esophageal Temperature /Feeding Tube, orange (8 French)	989803183581	

Cardiac Output (C.O.) Accessories

See Pressure accessories for PULSION continuous cardiac output accessories.

Description	Part No.	
Accessories common to both methods		
Accessories	Set of ice buckets	14455A
	Remote handswitch	15244A
PiCCO inline temperature probe	Latex free	M1646A
Right Heart Thermodilution		
C.O. Interface Cables	2.7 meter cable	M1642A
	2.4 m + 2.4 m cable	M1643A
Right heart catheter for thermodilution	(from Edwards Lifesciences)	831HF75
Edwards CO-Set+ (only with 23001A/B)	contact Edwards Lifesciences for information	
Injectate Probes	2.4 m injectate temp. probe (reusable)	23001A
	0.5 m injectate temp. probe (reusable)	23001B
	Ice bath temp. probe	23002A
Transpulmonary Thermodilution		
C.O. Interface Cables	2.4 m + 2.4 m cable	M1643A
PULSION Pressure Transducer Kits (pressure line available in various lengths)	Contact PULSION for information	
Pressure Interface Cable for disposable pressure transducer	PULSION PMK 206	

Mainstream CO₂ Accessories

Description	Part No.
CO ₂ Sensor	M2501A
Adult/Pediatric Airway Adapter (reusable)	M2513A
Infant Airway Adapter (reusable)	M2516A
Adult Airway Adapter (single-patient use)	M2533A
Infant Airway Adapter (single-patient use)	M2536A

Sidestream CO₂ Accessories

Description	Part No.
CO ₂ Sensor	M2741A
Nasal and Oral-Nasal Cannulas	
CO ₂ Nasal Cannula, Adult	M2744A
CO ₂ Nasal Cannula, Pediatric	M2745A
CO ₂ Nasal Cannula, Infant	M2746A
CO ₂ /O ₂ Nasal Cannula, Adult	M2750A
CO ₂ /O ₂ Nasal Cannula, Pediatric	M2751A
CO ₂ /O ₂ Nasal Cannula, Infant	989803144471
CO ₂ Oral-Nasal Cannula, Adult	M2756A
CO ₂ Oral-Nasal Cannula, Pediatric	M2757A
CO ₂ /O ₂ Oral-Nasal Cannula, Adult	M2760A
CO ₂ /O ₂ Oral-Nasal Cannula, Pediatric	M2761A
Airway Adapters	
Airway Adapter Set, ET > 4.0 mm	M2768A
Airway Adapter Set, ET ≤ 4.0 mm	989803144531
Airway Adapter Set H, ET > 4.0 mm	M2772A
Airway Adapter Set H, ET ≤ 4.0 mm	M2773A
Straight Sample Lines	
Straight Sample Line	M2776A
Straight Sample Line H	M2777A

Mainstream CO₂ Accessories (for M3016A)

Description	Part No.
CO ₂ Sensor	M1460A
Standard Airway Adapter (reusable)	M1465A
Small Airway Adapter (reusable)	14363A

Microstream CO₂ Accessories

- "FilterLine Set" is a combination of a FilterLine with an Airway Adapter.
- "H" in the accessory name indicates suitability for humidified ventilation and longer usage due to the active removal of humidity from the sample line.
- "Smart CapnoLine" is a combined oral-nasal FilterLine.
- "Smart CapnoLine O₂" is a combined oral-nasal-O₂-CO₂ FilterLine.
- "NIV Line" is a nasal FilterLine suitable for mask ventilation (for example, C-PAP).
- The accessories are supplied in packs of 25.
- Extension is not compatible with the M2786A Infant/Neonatal Flow Sensor for the spirometry measurement (M1014A).

NOTE

Not all accessories are available in all countries.

Description	Part Number	Part Number for Long Version
Accessories for Intubated Patients		
FilterLine® SET Adult/Pediatric	M1920A	989803160241
FilterLine® H SET Adult/Pediatric	M1921A	989803160251
FilterLine® H SET Infant/Neonatal	M1923A	989803160261
VitaLine™ H SET Adult/Pediatric	989803159571	
VitaLine™ H SET Infant/Neonate	989803159581	
Accessories for Non-Intubated Patients		
CapnoLine® H Adult	M4689A	
CapnoLine® H Pediatric	M4690A	
CapnoLine® H Infant/Neonatal	M4691A	989803178011
CapnoLine® H O ₂ Adult	M4680A	
CapnoLine® H O ₂ Pediatric	M4681A	
CapnoLine® H O ₂ Infant/Neonatal	989803178001	
NIV Line™ Adult	M4686A	
NIV Line™ Pediatric	M4687A	
Nasal FilterLine® Infant/Neonatal	989803178021	
Nasal Filterline® O ₂ Adult	989803179101	989803179111

Description	Part Number	Part Number for Long Version
Nasal Filterline® O ₂ Pediatric	989803179121	
Smart CapnoLine® O ₂ Adult	M2522A	989803160281
Smart CapnoLine® H O ₂ Adult	989803177951	989803177961
Smart CapnoLine® O ₂ Pediatric	M2520A	989803160271
Smart CapnoLine® H O ₂ Pediatric	989803177971	989803177981
Smart CapnoLine® Adult	M2526A	989803160301
Smart CapnoLine® Pediatric	M2524A	
Accessories for Endoscopic Procedures		
Smart CapnoLine® Guard	989803178031	
Smart CapnoLine® Guard O ₂	989803178041	989803178051
Hook and Loop Strap	989803178071	

Spirometry Accessories

Description	Part No.
Adult/Pediatric Flow Sensor	M2785A
Neonatal Flow Sensor	M2786A
Adult/Pediatric CO ₂ /Flow Sensor	M2781A
Neonatal CO ₂ /Flow Sensor	M2782A
Pediatric CO ₂ /Flow Sensor	M2783A

Measurement of CO₂ and Spirometry with Neonates

For measurement of CO₂ and Spirometry with neonates, the use of the M3014A Mainstream CO₂ Extension, the M1014A Spirometry Module and the M2782A Combined CO₂/Flow Sensor is **recommended**.

The M1923A Filterline H Set Infant/Neonatal used for Microstream CO₂ measurement with the M3015A Extension is **not compatible** with the M2786A Infant/Neonatal Flow Sensor for the spirometry measurement (M1014A).

tcGas Accessories



This symbol indicates that the specified transducer (but not its membranes) is designed to have special protection against electric shocks (particularly regarding allowable leakage currents), and is defibrillator proof.

Description	Part No.
tcpO₂/CO₂ transducer	M1918A
Accessory Kit for M1918A (O-ring remover, absorbent paper, electrolyte solution, 12 replacement membranes)	15209-60010
Application Kit for M1918A (4x25 disposable fixation rings, contact fluid)	15209-60020
tcpO₂/CO₂ transducer	M1918B¹
Accessory Kit for M1918B (10 replacement membranes, electrolyte solution)	989803151951 ¹
Application Kit for M1918B (4x25 disposable fixation rings, contact fluid)	989803151961 ¹
Calibration gas - 6 gas bottles	15210-60010
Calibration gas - 6 gas bottles (Europe and Japan only)	15210-64010
Replacement tubing (5 tubes)	M2205A
Calibration unit	15210B
Radiometer TCC3 calibration unit (available from Radiometer)	n/a

¹May not be available in all countries due to pending regulatory clearance

EEG Accessories

Description	Part No.
Trunk Cable 2.7 m	M2268A
Trunk Cable, 1.0 m	M2269A
Reusable 80-cm-long 5-lead cables with 10 mm silver/silverchloride leadwired cup electrodes (Adult)	M1931A
Reusable 80 cm 5-lead cables with 6 mm silver/silverchloride leadwired cup electrodes (Pediatric/Neonatal)	M1932A
Reusable 80 cm 5-lead cables with clip	M1934A
Disposable EEG electrodes	M1935A
EC2™ Electrode Cream (conductive paste)	M1937A

BIS Accessories

To re-order sensors, contact Covidien llc. BIS sensors are not available from Philips.

SO₂ Accessories for M1021A

Contact your local Hospira representative for information on accessories. They are not available from Philips.

Description	Hospira Part No.
Optical Module	50131
Hospira Opticath [®] Catheter family (SvO ₂ , ScvO ₂)	Contact Hospira for part numbers of compatible catheters

SO₂ Accessories for M1011A

Contact your local PULSION or Edwards representative for information on accessories. They are not available from Philips.





Description	Product Number (Order Number)
Philips SO ₂ Optical Module	989803151591
Pulsion: CeVOX Fiberoptic Probe family (ScvO ₂)	Contact PULSION for part numbers of compatible probes
Edwards: Philips-compatible versions of the PreSep Catheter (ScvO ₂) or Swan-Ganz Oximetry Catheter (SvO ₂) families	Contact Edwards for part numbers of compatible catheters

NMT Accessories

Description	Product Number (Order Number)
IntelliVue NMT Patient Cable (reusable)	989803174581

Symbols on the Accessory Packaging

The following symbols can be printed on the accessory packaging:

Symbol	Meaning
	Temperature limitations for storage
	Humidity limitations for storage
	Contents of the packaging are not sterile.
	Contents of the packaging are not made with natural rubber latex.
Rx only	Prescription use only
	Manufacturer information

Recorder Accessories

Description	Part No.
For the M1116B recorder:	
10 rolls of paper	40477A
80 rolls of paper	40477B
For the integrated recorder (MX400/MX450) and the M1116C recorder	
10 rolls of paper	M4816A
80 rolls of paper	M4817A

Battery Accessories

Description	Part No.
Lithium Ion Smart Battery 1Ah (internal battery for X2)	M4607A
Lithium Ion Smart Battery 6Ah (for MX400/MX450/MX500/MX550)	M4605A
Battery Charger and Conditioner (requires size adapter 451261017451 to charge M4607A battery)	865432
Size adapter for M4607A battery	451261017451

Specifications

The specifications in this section apply to the MX 400/MX450, MX500/MX550, MX600, MX700 and MX800 patient monitors.

The monitors are not user installable. They must be installed by qualified service personnel.

Indications for Use

The monitors are indicated for use by health care professionals whenever there is a need for monitoring the physiological parameters of patients.

The monitors are intended to be used for monitoring and recording of, and to generate alarms for, multiple physiological parameters of adults, pediatrics, and neonates. The monitors are intended for use by trained healthcare professionals in a hospital environment.

The MX400/MX450/MX500/MX550 monitors are additionally intended for use in transport situations within hospital environments.

The monitors are only for use on one patient at a time. They are not intended for home use. Not therapeutic devices. The monitors are for prescription use only.

The ECG measurement is intended to be used for diagnostic recording of rhythm and detailed morphology of complex cardiac complexes (according to AAMI EC 11).

ST segment monitoring is intended for use with adult patients only and is not clinically validated for use with neonatal and pediatric patients.

The transcutaneous gas measurement (tcGas) is restricted to neonatal patients only.

BIS is intended for use under the direct supervision of a licensed health care practitioner or by personnel trained in its proper use. It is intended for use on adult and pediatric patients within a hospital or medical facility providing patient care to monitor the state of the brain by data acquisition of EEG signals. The BIS may be used as an aid in monitoring the effects of certain anesthetic agents. Use of BIS monitoring to help guide anesthetic administration may be associated with the reduction of the incidence of awareness with recall in adults during general anesthesia and sedation.

The SSC Sepsis Protocol, in the ProtocolWatch clinical decision support tool, is intended for use with adult patients only.

The Integrated Pulmonary Index (IPI) is intended for use with adult and pediatric (1 to 12 years) patients only. The IPI is an adjunct to and not intended to replace vital sign monitoring.

The derived measurement Pulse Pressure Variation (PPV) is intended for use with sedated patients receiving controlled mechanical ventilation and mainly free from cardiac arrhythmia. The PPV measurement has been validated only for adult patients.

The IntelliVue NMT Module is intended to be used as an objective neuromuscular transmission monitor, using accelerometry for measuring the muscle contraction following an electrical stimulation of a peripheral nerve. The NMT Module is intended to be used with adult and pediatric patients.

Restricted Availability

Following new features and functionality may not be available in all geographies:

- Smart Alarm delays
- IntelliVue Information Center iX

Use Environment

Hospital Environment

The monitors are suitable for use in all medically used rooms which fulfill the requirements regarding electrical installation according to IEC 60364-7-710 "Requirements for special installations or locations - Medical locations", or corresponding local regulations.

WARNING

The monitors are not intended for use in an MRI environment or in an oxygen-enriched environment (for example, hyperbaric chambers).

Physical Security and Limited Access to the Monitor

Access to the monitor must be limited to authorized users. It is important that you consider physical security measures to ensure that unauthorized users cannot gain access.

Manufacturer's Information

You can write to **Philips** at this address

Philips Medizin Systeme Boeblingen GmbH
Hewlett-Packard-Str. 2
71034 Boeblingen
Germany

Visit our website at: www.healthcare.philips.com/us/.

© Copyright 2013. Koninklijke Philips N.V. All Rights Reserved.

BIS Manufacturer's Information

BISx, the BIS Engine, the DSC, the Patient Interface Cable and the BIS Sensor are manufactured by Covidien:

Covidien llc
15 Hampshire Street
Mansfield, MA 02048
USA

Trademark and License Acknowledgment

PiCCO™ is a trademark of PULSION Medical Systems AG.

Bispectral Index and BIS are trademarks of Covidien llc, and are registered in the USA, EU and other countries.

Microstream®, FilterLine®, and Smart CapnoLine® are trademarks or registered trademarks of Oridion Systems Ltd.

Citrix® and ICA® (Independent Computing Architecture) are registered trademarks of Citrix Systems, Inc.

The following are trademarks of Nellcor Puritan Bennett Incorporated: Nellcor®, Durasensor®, Dura-Y®, Oxiband®, Oxicliq®, OxiMax®, MAX-FAST® is a trademark of Mallinckrodt Inc.

Masimo®, Masimo SET®, and LNOP are federally registered trademarks of the Masimo Corporation.















Transpac® and SafeSet™ are trademarks of ICU Medical, Inc.







































Other product and company names mentioned in this book may be trademarks of their respective owners.

The monitors use Open Source Software. For details check the license screen via **Main Setup, Revisions, OSS Licenses**.

Symbols

These symbols can appear on the monitor and its associated equipment.

Symbols					
	Caution, refer to accompanying documents		Protective earth		Equipotential grounding
					
					
	Start a measurement		Stop a measurement		Applied part has special protection against electric shocks (Type BF according to IEC 60601-1) and is defibrillator proof
	Standby		FMS power-on indicator		Error LED
	Alternating current		Connection direction indicator		Connection direction indicator

Symbols					
	Electrical input indicator (In some cases gas input indicator)		Electrical output indicator (In some cases gas output indicator)		Connector has special protection against electric shocks and is defibrillator proof (Type CF according to IEC 60601-1)
	Gas input indicator		Gas output indicator		Quick mount release
	Manufacturer's name and address		USB interface		Data input/output symbol
	Non-ionizing radiation symbol		Identifies year and month of manufacture		Always use separate collection for waste electrical and electronic equipment (WEEE)
	Pressure connector		NBP connector		Cardiac Output connector
	Temperature connector		Monitor supports 12-lead ECG		SpO ₂ connector
	Masimo SET technology		Nellcor OxiMax compatible		Uses FAST SpO ₂ algorithm
	Silence Alarms		Alarms On/Off		Alarms Switched Off
	Main Screen		SmartKeys		Back key
	Purge flow tubing with air		Zero the invasive pressure transducer		Enter the measurement setup menu
	ECG Sync Output/ Analog ECG Output		Followed by two alphanumeric characters, indicates ingress protection grade		Indicates location of catalog number
	Indicates location of service number		Rechargeable battery symbol		Battery LED
	Indication for battery placement in battery compartment		Enter the measurement setup menu to start a calibration		

Installation Safety Information

WARNING

If multiple instruments are connected to a patient, the sum of the leakage currents may exceed the limits given in IEC/EN 60601-1, IEC 60601-1-1, UL 60601-1. Consult your service personnel.

Grounding	The monitor must be grounded during operation. If a three-wire receptacle is not available, consult the hospital electrician. Never use a three-wire to two-wire adapter.
Equipotential Grounding	If the monitor is used in internal examinations on the heart or brain, ensure that the room incorporates an equipotential grounding system to which the monitor has a separate connection.
Combining equipment	Combinations of medical equipment with non-medical equipment must comply with IEC 60601-1-1. Never use a multiple portable socket-outlet or extension cord when combining equipment unless the socket outlet is supplied specifically for use with that equipment.
Fusing	The monitor uses double fusing (line and neutral).
Network Cables	All network cables must be unshielded.

Connectors

The actual placement of boards and configuration of connections for your monitor depends on how your hardware has been configured. See the symbols table (“Symbols” on page 445) to see which symbols are used to mark the connections.

WARNING

Connect only medical devices to the ECG output connector socket.

MX400/450



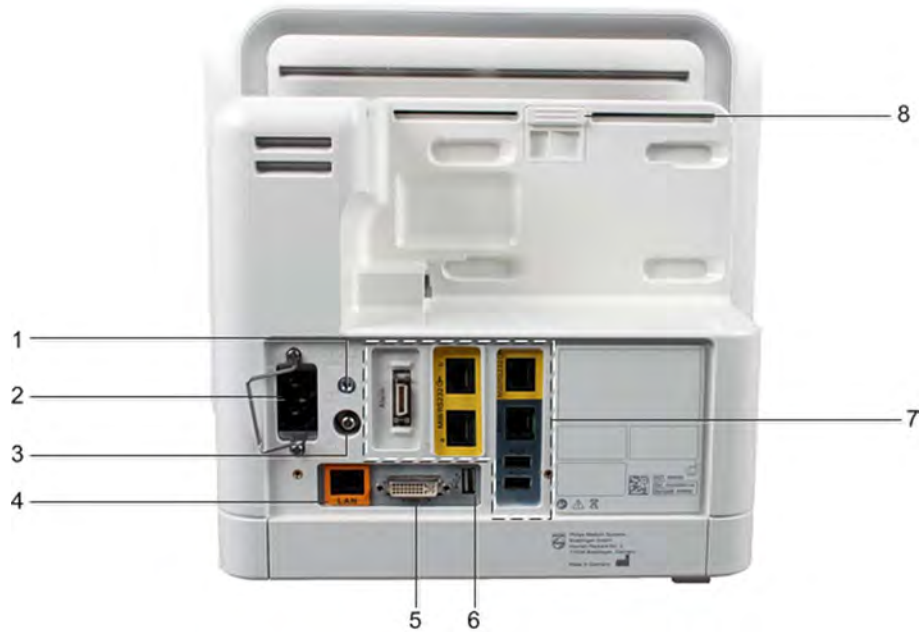

Rear of the Monitor

Shown here without the standard spillage cover that protects the connectors.



1	Protective earth screw hole
2	AC power input with clamp
3	Equipotential ground connector
4	Wired network connector (color-coded in orange)
5	Video out connector (digital/analog)
6	USB rear connector (for remote control, keyboard, pointing devices, printer)
7	Optional interfaces
8	Release switch for a connected multi-measurement module

Optional Interfaces

Optional Interface	Description
 <p>The image shows a white flexible nurse call interface card. It has a central RJ45 port and two smaller ports on either side. The word "Alarm" is printed vertically on the left side of the card.</p>	Flexible nurse call interface card
 <p>The image shows a yellow dual medical information bus (MIB) RS232 interface card. It features two RJ45 ports labeled 'a' and 'b'. The text 'MIB/RS232 G+' is printed vertically on the left side.</p>	Dual medical information bus (MIB) RS232 Interface card (color-coded yellow)
 <p>The image shows a dark gray IntelliBridge EC10 interface board. It has a single RJ45 port and a power button. The text 'IntelliBridge EC10' is printed on the left side.</p>	IntelliBridge EC10 interface board (color-coded dark gray)
 <p>The image shows an advanced system interface card. It is color-coded yellow and dark gray. It features an MIB/RS232 G+ port at the top, an Alarm port in the middle, and two USB ports at the bottom labeled 'a' and 'b'.</p>	<p>Advanced system interface: Single medical information bus (MIB) RS232 Interface card (color-coded yellow) Nurse call Additional USB slots</p>

Left Side of the Monitor



- 1 MSL interface link
- 2 Integrated recorder
- 3 ECG Sync Output/Analog ECG output connector

Right Side of the Monitor



- 1 Optional USB slot
- 2 Battery compartment

MX500/550

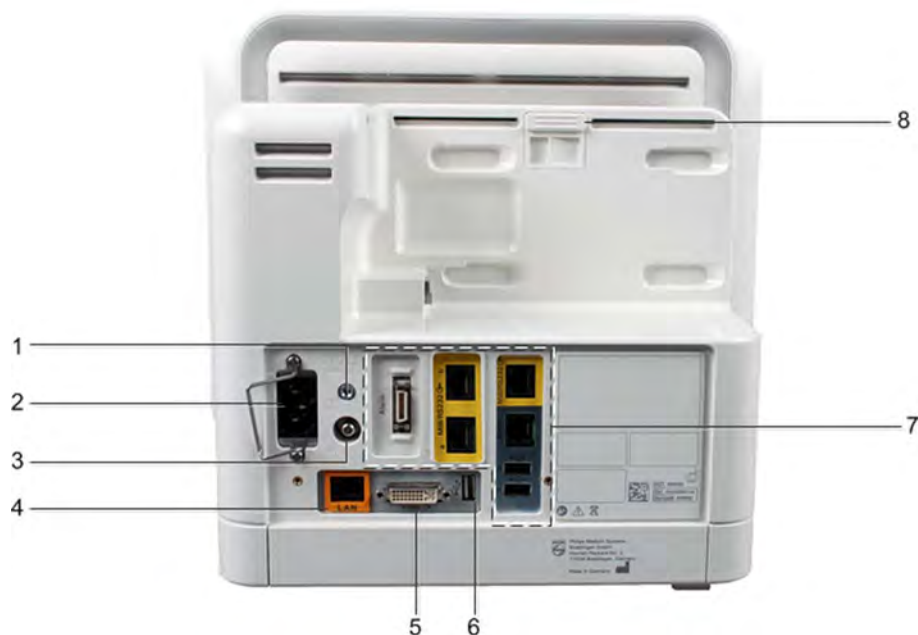

Rear of the Monitor



1	Protective earth screw hole
2	AC power input with clamp
3	Equipotential ground connector
4	Wired network connector (color-coded in orange)
5	Video out connector (digital/analog)
6	USB rear connector (for remote control, keyboard, pointing devices, printer)
7	Optional interfaces
8	Release switch for connected measurement modules

Optional Interfaces

Optional Interface	Description
	Flexible nurse call interface card

Optional Interface	Description
	<p>Dual medical information bus (MIB) RS232 Interface card (color-coded yellow)</p>
	<p>IntelliBridge EC10 interface board (color-coded dark gray)</p>
	<p>Advanced system interface: Single medical information bus (MIB) RS232 Interface card (color-coded yellow) Nurse call Additional USB slots</p>

Left Side of the Monitor



- 1 MSL interface link
- 2 3 slots for measurement modules
- 3 ECG Sync Output/Analog ECG output connector

Right Side of the Monitor



- 1 Optional USB slot
- 2 Battery compartment

MX600/700/800

Rear of the Monitor

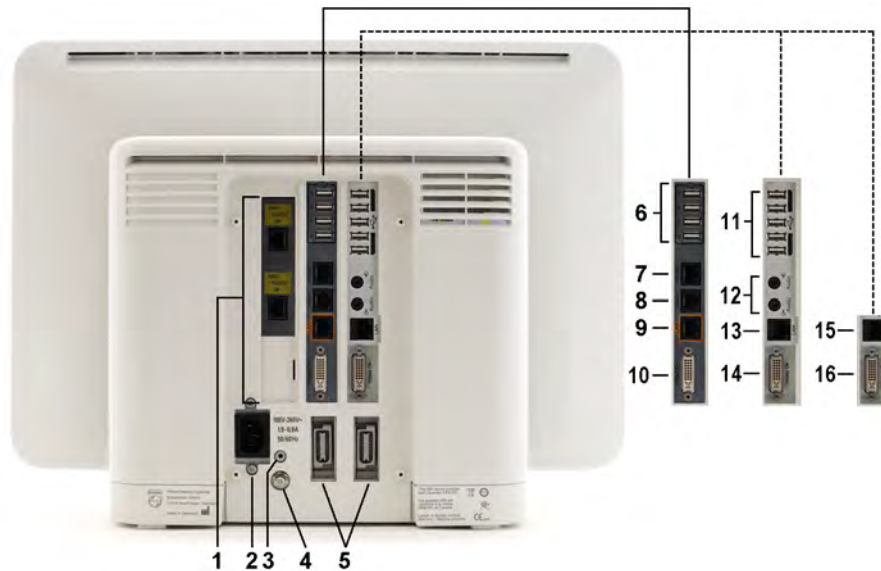

1	Serial/MIB (RS232) interface cards, type RJ45 or Flexible Nurse Call interface card or combination of both (optional)
2	AC power input
3	Protective earth screw hole
4	Equipotential ground connector
5	Measurement link connectors (MSL) (Two standard in MX800, one standard in MX600/700)
6	USB rear connectors (for remote control, keyboard, pointing devices, printer)
7	Serial RS232 connector
8	Nurse Call
9	Wired network connector
10	Video out connector (digital/analog)
The following connectors are only present with the iPC	
11	USB rear connectors (for keyboard, pointing devices, printer)
12	Audio in/out
13	Local Area Network
14	Video out connector (digital/analog)
The following connectors are only present with the Independent Display Interface	
15	Serial RS232 connector for touch
16	Video out connector (digital/analog)

Left Side of the Monitor



- 1 ECG Sync Output/Analog ECG output connector

Right Side of the Monitor



- 1 USB side connector (only present with the iPC)

Monitor Mounting Precautions

Mount the monitor using either the Philips Quick Mount or Fix Mount solution or another approved mounting solution. Select the mounting equipment and the mounting position so that no patient, operator or other person can be harmed by a monitor removed intentionally or released accidentally from the mount. When using the Quick Mount, be aware of the danger of accidental activation of the Quick Mount release button when lifting or moving items located under the monitor, such as pole mounts, etc. If in doubt, use the Philips Fix Mount solution to avoid such situations. Refer to the respective IntelliVue Monitor Service Manual, Installation Instructions chapter, for more details.

CAUTION

- Never carry a monitor by the handle when equipment is attached below it with the Quick Mount. To transport such equipment combinations, always support the equipment from below.
- Only use the bed hanger for the MX400/450/500/550 on beds with a support below the rail, to ensure that the monitor does not tilt.

Repositioning a Monitor on the Mounting Arm

Attempts to reposition the monitor should only be performed as described in the mounting hardware manufacturer's user documentation. If the mounting arm has a locking mechanism, ensure the locking mechanism is unlocked before attempting to reposition the monitor. Never pull on the monitor to tilt, swivel or otherwise reposition it - always hold on to the mounting hardware itself.

WARNING

Not adhering to these instructions when repositioning the monitor can cause damage to the monitor. In extreme cases, when force is applied to the monitor, it can result in the monitor falling from the mounting arm.

If, at any time, the monitor appears to be loose or insecurely mounted, contact your service personnel.

Altitude Setting

Altitude affects tcGas and CO₂ measurements. The monitor must be configured at installation to the correct altitude.

Monitor Safety Specifications

Philips

The monitors, together with the Multi-Measurement Modules (M3001A/M3002A), the Flexible Module Racks FMS-8 (M8048A) and FMS-4 (865243), and all modules and MMS extensions, comply with the Medical Device Directive 93/42/EEC.

Covidien

Covidien BISx, Covidien BIS Engine and Covidien DSC comply with the Medical Device Directive 93/42/EEC of 14 June 1993.

In addition, the product complies with:

IEC 60601-1:1988 + A1:1991 + A2:1995; EN 60601-1:1990 + A1:1993 + A2:1995; UL 60601-1:2003; CAN/CSA C22.2#601.1-M90 +Suppl. No. 1-94 + Am. 2; IEC 60601-1-1:2000; EN 60601-1-1:2001; IEC 60601-1-2:2001 + A1:2004; EN 60601-1-2:2001 + A1:2006.

The possibility of hazards arising from software errors was minimized in compliance with ISO 14971:2007, EN 60601-1-4:1996 + A1:1999 and IEC 60601-1-4:1996 + A1:1999.

Classification (according to IEC 60601-1): Class 1, Type CF, Continuous Operation. The BIS and NMT measurement use a Type BF applied part.

Physical Specifications

Product	Maximum Weight	W x H x D	Comments
MX800 Monitor	<12 kg (<26.4 lb)	<478 x 364 x 152 mm <18.82 x 14.33 x 5.98 in	without cable management
MX600/MX700 Monitor	<9.5 kg (<20.9 lb)	<392 x 321 x 163 mm <15.43 x 12.64 x 6.42 in	without cable management
MX550 Monitor	<7.3 kg (<16.1 lb)	<404 x 308 x 184 mm <15.91 x 12.13 x 7.24 in	
MX500 Monitor	<6.0 kg (<13.1 lb)	<327 x 288 x 182 mm <12.87 x 11.34 x 7.17 in	
MX450 Monitor	<5.9 kg (<12.9lb)	<327 x 288 x 182mm <12.87 x 11.34 x 7.17 in	
MX400 Monitor	<5.2 kg (<11.5lb)	<274 x 288 x 178 mm <10.79 x 11.34 x 7.01 in	
M3001A Multi-Measurement Module (MMS)	<650 g (<1.4 lb)	188 x 96.5 x 51.5 mm 7.4 x 3.8 x 2 in	
M3002A Multi-Measurement Module (MMS)	<1.25 kg (<2.8 lb)	188 x 99 x 86 mm 7.4 x 3.9 x 3.4 in	including battery, without handle or options
M3012A Hemodynamic MMS Extension	<550 g (<1.2 lb)	<190 x 98 x 40 mm <7.5 x 4 x 1.6 in	
M3014A Capnography MMS Extension	<500 g (<0.99 lb)	<190 x 98 x 40 mm <7.5 x 4 x 1.6 in	
M3015A Microstream CO ₂ MMS Extension	<550 g (<1.21 lb)	<190 x 98 x 40 mm <7.5 x 4 x 1.6 in	
M3016A Mainstream CO ₂ MMS Extension	<450 g (<0.99 lb)	<190 x 98 x 40 mm <7.5 x 4 x 1.6 in	
M8048A 8-Slot Flexible Module Rack (FMS-8)	<3500 g (<7.7 lb)	<320 x 135 x 120 mm 12.6 x 5.3 x 4.7 in	without plug-in modules
865243 4-Slot Flexible Module Rack (FMS-4)	<950 g (<2.09 lb)	<194 x 139 x 110 mm <7.64 x 5.47 x 4.33 in	without MMS Mount
M8025A Remote Alarm Device	<300 g (<0.7 lb)	62 x 125 x 63 mm 2.4 x 5 x 2.5 in	
M1006B Invasive Press Module	190 g (6.7 oz) Option #C01: 225 g (7.9 oz)	36 x 99.6 x 97.5 mm 1.4 x 3.9 x 3.8 in	
M1029A Temperature Module	215 g (7.6 oz)	36 x 99.6 x 97.5 mm 1.4 x 3.9 x 3.8 in	
M1012A Cardiac Output Module	225 g (7.9 oz)	36 x 99.6 x 97.5 mm 1.4 x 3.9 x 3.8 in	
M1014A Spirometry Module	250 g (8.8 oz)	36 x 99.6 x 97.5 mm 1.4 x 3.9 x 3.8 in	
M1018A Transcutaneous Gas Module	350 g (11.3 oz)	72.5 x 99.6 x 97.5 mm 2.9 x 3.9 x 3.8 in	
M1020B SpO ₂ Module	<250 g (<0.55 lb)	36 x 99.6 x 97.5 mm 1.4 x 3.9 x 3.8 in	
M1021A Mixed Venous Oxygen Saturation Module	460 g (13.04 oz)	72.5 x 99.6 x 97.5 mm 2.9 x 3.9 x 3.8 in	

40 Specifications

Product	Maximum Weight	W x H x D	Comments
M1011A SO ₂ Module	<200 g (<7.1 oz)	36 x 99.6 x 102.5 mm 1.4 x 3.9 x 4.0 in	
- Optical Module	<200 g (<7.1 oz)	50 x 30 x 120 mm 2.0 x 1.2 x 4.7 in	including 2.9 m cable
M1027A Electroencephalograph Module	210 g (7.4 oz)	36 x 99.6 x 97.5 mm 1.4 x 3.9 x 3.8 in	
M1034A BIS Interface Module	215 g (7.6 oz)	36 x 99.6 x 97.5 mm 1.4 x 3.9 x 3.8 in	without cables
BISx	499 g (1.1 lb)	diameter x height: 95.3 x 63.5 mm 3.8 x 2.5 in	with PIC Plus Cable (1.22 m, 4 ft) and cable to BIS module
- DSC Digital Signal Converter	130 g (4.6 oz) (without cabling)	66 x 25 x 107 mm 2.6 x 1.0 x 4.25 in	with PIC Plus Cable (1.22 m, 4 ft)
- BIS Engine	170 g (6.0 oz)	43 x 93 x 95 mm 1.7 x 3.7 x 3.7 in	
M1032A Vuelink Module	240 g (8.4 oz)	36 x 99.6 x 97.5 mm 1.4 x 3.9 x 3.8 in	
865115 IntelliBridge EC10 Module	200 g (7.0 oz)	36 x 99.6 x 102.5 mm 1.4 x 3.9 x 4.0 in	
865114 IntelliBridge EC5 Module	35 g (1.1 oz)	35 x 17 x 57 mm 1.4 x 0.7 x 2.1 in	with D-Sub 9-pin male or female connector
	25 g (0.8 oz)	21.5 x 17 x 65 mm 0.9 x 0.7 x 2.6 in	without cable and strain relief
M1116B Thermal Array Recorder Module	507.5 g (17.9 oz)	73 x 99.6 x 97 mm 2.9 x 3.6 x 3.9 in.	
865244 Remote Control	<250 g (<8.8 oz)	53 x 165 x 23 mm 2.1 x 6.5 x 0.9 in	without navigator knob
865383 IntelliVue NMT Module	300 g (10.6 oz)	36 x 103.5 x 110 mm 1.4 x 4.0 x 4.3 in	without cables

Environmental Specifications

The monitor may not meet the performance specifications given here if stored or used outside the specified temperature and humidity ranges.

When the monitor and related products have differing environmental specifications, the effective range for the combined products is that range which is common to the specifications for all products.

MX400/450/500/550 Monitor

MX400/450/500/550 Monitor		
Item	Condition	Range
Temperature Range	Operating	0 to 40 °C (32 to 104 °F)
		0 to 35°C (32 to 95°F) when charging the battery
		0 to 35°C (32 to 95°F) if an X2 is mounted on the rear.
		0 to 35°C (32 to 95°F) if IntelliVue Instrument Telemetry Wireless Network is connected.
	Storage	-20 to 60°C (-4 to 140°F)
Humidity Range	Operating	15% to 95% Relative Humidity (RH) (non condensing)
	Storage	5% to 95% Relative Humidity (RH) (non condensing)
Altitude Range	Operating	-500 m to 3000 m (10000 ft)
	Storage	-500 m to 4600 m (15000 ft)
Ingress Protection		IP21

MX600/700/800 Monitor

MX600/700/800 Monitor		
Item	Condition	Range
Temperature Range	Operating	0 to 40°C (32 to 100°F) 0 to 35°C (32 to 95°F) when equipped with the iPC
	Storage	-20 to 60°C (-4 to 140°F)
Humidity Range	Operating	15% to 95% Relative Humidity (RH) (non condensing)
	Storage	5% to 95% Relative Humidity (RH)
Altitude Range	Operating	-500 m to 3000 m (-1600 to 10000 ft)
	Storage	-500 m to 4600 m (-1600 to 15000 ft)
Ingress Protection		IPX1

X2 (M3002A) and External Power Supply (M8023A)

X2 (M3002A) and External Power Supply (M8023A)		
Item	Condition	Range
Temperature Range	Operating	0 to 40°C (32 to 104°F)
	Storage including transportation	-20 to 60°C (-4 to 140°F)
Temperature Range when charging the battery or when equipped with IntelliVue Instrument Telemetry or the IntelliVue 802.11 Bedside Adapter	Operating	0 to 35°C (32 to 95°F)

40 Specifications

X2 (M3002A) and External Power Supply (M8023A)		
Item	Condition	Range
Humidity Range	Operating	15% to 95% Relative Humidity (RH)
	Storage including transportation	5% to 95% Relative Humidity (RH)
Altitude Range	Operating	-500 m to 3000 m (-1600 to 10000 ft)
	Storage including transportation	-500 m to 4600 m (-1600 to 15000 ft)
	X2	IP32 (protected against ingress of water when the water is dripping vertically and the monitor is tilted up to 15°)

Devices for Acquiring Measurements and 8-Slot Flexible Module Rack

Multi-measurement Module M3001A, MMS Extensions M3016A M3015A, M3014A, M3012A, Measurement Modules, and 8-Slot Flexible Module Rack M8048A		
Item	Condition	Range
Temperature Range	Operating	0 to 45°C (32 to 113°F)
	Non-operating	-40 to 70°C (-40 to 158°F)
Humidity Range	Operating	95% Relative Humidity (RH) max. @ 40°C (104°F). M3015A only non-condensing.
	Non-operating	90% Relative Humidity (RH) max. @ 65°C (150°F)
Altitude Range	Operating	-500 m to 4600 m (-1600 to 15000 ft)
	Non-operating	-500 m to 15300 m (-1600 to 50000 ft)

4-Slot Flexible Module Rack

4-Slot Flexible Module Rack 865243		
Item	Condition	Range
Temperature Range	Operating	0 to 40°C (32 to 100°F)
	Storage	-20 to 60°C (-4 to 140°F)
Humidity Range	Operating	15% to 95% Relative Humidity (RH) (non condensing)
	Storage	5% to 95% Relative Humidity (RH)
Altitude Range	Operating	-500 m to 3000 m (-1600 to 10000 ft)
	Storage	-500 m to 4600 m (-1600 to 15000 ft)
Ingress Protection		IPX1

Thermal Array Recorder Module M1116B/C

Thermal Array Recorder Module M1116B/C		
Item	Condition	Range
Temperature Range	Operating	+5 to 45°C (41 to 113°F)
	Non-operating	-10 to 70°C (14 to 158°F)
Humidity Range	Operating	95% Relative Humidity (RH) max. @ 40°C (104°F) (non condensing)
	Non-operating	90% Relative Humidity (RH) max. @ 65°C (150°F) (non condensing)
Altitude Range	Operating	up to 3048 m (10000 ft)
	Non-operating	up to 3048 m (10000 ft)

Remote Control

Remote Control 865244		
Item	Condition	Range
Temperature Range	Operating	0 to 40°C (32 to 100°F)
	Storage	-20 to 60°C (-4 to 140°F)
Humidity Range	Operating	15% to 95% Relative Humidity (RH) (non condensing)
	Storage	5% to 95% Relative Humidity (RH)
Altitude Range	Operating	-500 m to 3000 m (-1600 to 10000 ft)
	Storage	-500 m to 4600 m (-1600 to 15000 ft)

EMC and Radio Regulatory Compliance

This ISM device complies with Canadian ICES-001. Cet appareil ISM est conforme à la norme NMB-001 du Canada.

Short Range Radio Interface (Monitors and 865244 Remote Control)

FCC and Industry Canada Radio Compliance: This device complies with Part 15 of the FCC Rules and RSS-210 of Industry Canada. Operation is subject to the following two conditions: (1) this device may not cause harmful interference, and (2) this device must accept any interference received, including interference that may cause undesired operation. Any changes or modifications to this equipment not expressly approved by Philips Medical Systems may cause harmful radiofrequency interference and void your authority to operate this equipment.



The radio component contained in this device is in compliance with the essential requirements and other relevant provisions of Council Directive 1999/5/EC (Radio Equipment and Telecommunications Terminal Equipment Directive)

In addition the product complies with: ETSI EN 300 328; AS/NZS 4771+A1; ARIB STD-T66.

Class 1 radio equipment.

To obtain a copy of the original Declaration of Conformity, please contact Philips at the address given in the “Manufacturer's Information” section of these Instructions for Use.

IntelliVue 802.11 Bedside Adapter (Option J35 Wireless Network Adapter)

FCC and Industry Canada Radio Compliance: This device complies with Part 15 of the FCC Rules and RSS-210 of Industry Canada. Operation is subject to the following two conditions: (1) this device may not cause harmful interference, and (2) this device must accept any interference received, including interference that may cause undesired operation. Any changes or modifications to this equipment not expressly approved by Philips Medical Systems may cause harmful radiofrequency interference and void your authority to operate this equipment.

The maximum antenna gain permitted (for devices in the 5250-5350 MHz and 5470-5725 MHz bands) complies with the e.i.r.p. limits as stated in RSS-210.

The maximum antenna gain permitted (for devices in the 5725-5825 MHz band) complies with the e.i.r.p. limits specified for point-to-point operation, as stated in RSS-210.

The device for the band 5150-5250 MHz is only for indoor usage to reduce potential for harmful interference to co-channel mobile satellite systems.

CAUTION

High power radars are allocated as primary users (meaning they have priority) of 5250-5350 MHz and 5650-5850 MHz and these radars could cause interference and /or damage to LE-LAN devices.

IntelliVue 802.11 Bedside Adapter CE compliances:



This device is compliant to Council Directive 2006/95/EC (Low voltage directive) & 2004/108/EC (EMC directive) & 1999/5/EC (Radio Equipment and Telecommunications Terminal Equipment Directive)



The radio device used in this product is in compliance with the essential requirements and other relevant provisions of Directive 1999/5/EC (Radio Equipment and Telecommunications Terminal Equipment Directive). Class 2 radio equipment. Member states may apply restrictions on putting this device into service or placing it on the market. This product is intended to be connected to the Publicly Available Interfaces (PAI) and used throughout the EEA.

IntelliVue Instrument Telemetry ISM (2.4GHz Option J47 WMTS Adapter)

FCC and Industry Canada Radio Compliance: This device complies with Part 15 of the FCC Rules and RSS-210 of Industry Canada. Operation is subject to the following two conditions: (1) this device may not cause harmful interference, and (2) this device must accept any interference received, including interference that may cause undesired operation. Any changes or modifications to this equipment not expressly approved by Philips Medical Systems may cause harmful radiofrequency interference and void your authority to operate this equipment.



The radio device used in this product is in compliance with the essential requirements and other relevant provisions of Directive 1999/5/EC (Radio Equipment and Telecommunications Terminal Equipment Directive). Class 2 radio equipment. Member states may apply restrictions on putting this device into service or placing it on the market. This product is intended to be connected to the Publicly Available Interfaces (PAI) and used throughout the EEA.

IntelliVue Instrument Telemetry WMTS (US only)

FCC Radio Compliance: This device complies with Part 15 of the FCC Rules. Operation is subject to the following two conditions: (1) this device may not cause harmful interference, and (2) this device must accept any interference received, including interference that may cause undesired operation. Operation of this equipment requires the prior coordination with a frequency coordinator designated by the FCC for the Wireless Medical Telemetry Service.

Monitor Performance Specifications

MX400/450/500/550 Performance Specifications

MX400/450/500/550		
Power Specifications	Power Consumption	<70 W average
	Line Voltage	100 to 240 V
	Current	1.2 to 0.5 A
	Frequency	50/60 Hz
Battery Specifications		
MX400	Operating time (with one fully charged battery)	Basic monitoring configurations 5 hours (Brightness is set to Optimum , MMS connected, NBP measurement every 15 minutes).
		Extended monitoring configuration: 3.5 hours (Brightness set to Optimum , MMS and MMS extension connected, NBP every 15 minutes, Recorder, Pressure, Temperature modules connected)
	Charge Time	When monitor is off: approx. 3 hours When monitor is in use: approx. 5 hours
MX450	Operating time (with one fully charged battery)	Basic monitoring configurations 4 hours (Brightness is set to Optimum , MMS connected, NBP measurement every 15 minutes).
		Extended monitoring configuration: 3 hours (Brightness set to Optimum , MMS and MMS extension connected, NBP every 15 minutes, Recorder, Pressure, Temperature modules connected)
	Charge Time	When monitor is off: approx. 3 hours When monitor is in use: approx. 5 hours
MX 500	Operating time (with one fully charged battery)	Basic monitoring configurations 3 hours (Brightness is set to Optimum , MMS connected, NBP measurement every 15 minutes).
		Extended monitoring configuration: 2.5 hours (Brightness set to Optimum , MMS and MMS extension connected, NBP every 15 minutes, Recorder, Pressure, Temperature modules connected)
	Charge Time	When monitor is off: approx. 3 hours When monitor is in use: approx. 5 hours
MX 550	Operating time (with one fully charged battery)	Basic monitoring configurations 2.5 hours (Brightness is set to Optimum , MMS connected, NBP measurement every 15 minutes).
		Extended monitoring configuration: 2 hours (Brightness set to Optimum , MMS and MMS extension connected, NBP every 15 minutes, Recorder, Pressure, Temperature modules connected)
	Charge Time	When monitor is off: approx. 3 hours When monitor is in use: approx. 5 hours

MX400/450/500/550		
Sounds	Audible feedback for user input Prompt tone QRS tone, or SpO ₂ modulation tone 4 different alarm sounds Remote tone for alarms on other beds in network Tone for Timer expired	
Display Wave Speeds	Available for standard waves	6.25 mm/s, 12.5 mm/s, 25 mm/s, 50 mm/s with $\pm 5\%$ accuracy (guaranteed only for integrated displays)
	Available for EEG and BIS waves	6.25 mm/s, 12.5 mm/s, 15 mm/s, 25 mm/s, 30 mm/s, 50 mm/s with $\pm 5\%$ accuracy (guaranteed only for integrated displays)
Trends	Resolution	12, 16, 24 or 32 numerics @ 12 sec, 1 minute, 5 minute resolution
	Information	Multiple choices of number of numerics, resolution and duration depending on trend option and application area. For example: neonatal extended 12 numerics, 24 hours @ 12 secs or 32 numerics 32 hours @ 1 minute intensive care extended: 16 numerics 120 hours @ 5 minutes anesthesia extended 32 numerics 9 hours @ 12 seconds
High Res Trend Waves	Measurements available	HR, SpO ₂ , Resp, tcpO ₂ , Pulse, Perf, tcpCO ₂ , CO ₂ , ABP, PAP, CVP, ICP, CPP, BIS, CCO, AWP, Anesthetic Agents, Delta SpO ₂ , inO ₂
	Resolution	Measurement samples are taken at a resolution of four samples per second
	Update speed	Waves are drawn at a speed of 3 cm/minute
Events	Information	Trigger condition and time, event classification and associated detailed view of episode data
	Episode data	Configurable, either: 4 minutes of high resolution trend or 20 minutes of numerics trend @ 12 sec. resolution or 15 seconds of 4 waves @ 125 samples/sec. (Snapshot) including all current numerics, alarms and inops
	Capacity (max.)	25 or 50 events for either 8 or 24 hours

MX400/450/500/550		
Alarm Signal	System alarm delay The system alarm delay is the processing time the system needs for any alarm to be indicated on the monitor, after the measurement has triggered the alarm.	less than 4 seconds
	Delay for alarm availability on the network This is the time needed after alarm indication on the monitor until the alarm signal is available on the network, to the IntelliVue Information Center or for transmission to other systems.	less than 5 seconds
	Pause duration	1,2,3 minutes or infinite, depending on configuration
	Extended alarm pause	5 or 10 minutes
	Sound pressure range	min. 0 dB(A) max. 45-85 dB(A)
	Review Alarms	Information
Capacity		300 items
Real Time Clock	Range	from: January 1, 1997, 00:00 to: December 31, 2080, 23:59
	Accuracy	better than 4 seconds per day
	Hold Time	infinite if powered by AC; otherwise at least 24 hours
Buffered Memory	Hold Time	if powered by AC: infinite without power: at least 8 hours
	Contents	Active settings, trends, patient data, realtime reports, events, review alarms

MX600/700/800 Performance Specifications

MX600/700/800		
Power Specifications	Power Consumption	<200 W average
	Line Voltage	100 to 240 V
	Current	1.9 to 0.9 A
	Frequency	50/60 Hz
Indicators	Alarms Off	red or yellow LED with crossed out alarms symbol
	Alarms	red/yellow/light blue (cyan) LED
	On/Standby/Error	green/red LED integrated in power switch
	External Power	green LED
Sounds	Audible feedback for user input Prompt tone QRS tone, or SpO ₂ modulation tone 4 different alarm sounds Remote tone for alarms on other beds in network Tone for Timer expired	

MX600/700/800		
Trends	Resolution	12, 16, 24 or 32 numerics @ 12 sec, 1 minute, 5 minute resolution
	Information	Multiple choices of number of numerics, resolution and duration depending on trend option and application area. For example: neonatal extended 12 numerics, 24 hours @ 12 secs or 32 numerics 32 hours @ 1 minute intensive care extended: 16 numerics 120 hours @ 5 minutes anesthesia extended 32 numerics 9 hours @ 12 seconds
High Res Trend Waves	Measurements available	HR, SpO ₂ , Resp, tcpO ₂ , Pulse, Perf, tcpCO ₂ , CO ₂ , ABP, PAP, CVP, ICP, CPP, BIS, CCO, AWP, Anesthetic Agents, Delta SpO ₂ , inO ₂
	Resolution	Measurement samples are taken at a resolution of four samples per second
	Update speed	waves are drawn at a speed of 3 cm/minute
Events	Information	trigger condition and time, event classification and associated detailed view of episode data
	Episode data	configurable, either: 4 minutes of high resolution trend or 20 minutes of numerics trend @ 12 sec. resolution or 15 seconds of 4 waves @ 125 samples/sec. (Snapshot) including all current numerics, alarms and inops
	Capacity (max.)	25 or 50 events for either 8 or 24 hours
Alarm Signal	System alarm delay The system alarm delay is the processing time the system needs for any alarm to be indicated on the monitor, after the measurement has triggered the alarm.	less than 4 seconds
	Delay for alarm availability on the network This is the time needed after alarm indication on the monitor until the alarm signal is available on the network, to the IntelliVue Information Center or for transmission to other systems.	less than 5 seconds
	Pause duration	1,2,3 minutes or infinite, depending on configuration
	Extended alarm pause	5 or 10 minutes
	Sound pressure range	min. 0 dB(A) max. 45-85 dB(A)
	Review Alarms	Information
	Capacity	300 items
Real Time Clock	Range	from: January 1, 1997, 00:00 to: December 31, 2080, 23:59
	Accuracy	better than 4 seconds per day
	Hold Time	infinite if powered by AC; otherwise at least 24 hours

MX600/700/800		
Buffered Memory	Hold Time	if powered by AC: infinite without power: at least 8 hours
	Contents	Active settings, trends, patient data, realtime reports, events, review alarms

X2 Performance Specifications

X2 (M3002A) Performance Specifications		
Power Specifications	Power consumption	<12 W average <30 W while battery is loading
	Operating Voltage	36 to 60 V DC floating
Battery Specifications	Operating Time (with new, fully charged battery at 25°C)	Basic monitoring configuration: 2.5 hours (Brightness set to optimum, ECG/Resp, SpO ₂ measurements in use, NBP measurement every 15 minutes)
	Charge Time	When X2 is off: 2 hours When X2 is in use, and connected to a monitor, without extensions: 12 hours approx. When X2 is in use, and connected to the external power supply (M8023A), without extensions: 12 hours approx.
Indicators	Alarms Off	red or yellow LED with crossed-out alarm symbol
	Alarms	red/yellow/light blue (cyan) LED
	On/Standby / Error	green / red LED
	AC Power	green LED
	Battery	yellow (charging)/red blinking (empty) LED
External Power	External Power	green LED
	Sounds	Audible feedback for user input Prompt tone QRS tone, or SpO ₂ modulation tone 4 different alarm sounds
Trends	Resolution	12 or 16 numerics @ 12 sec, 1 minute, 5 minute resolution.
	Information	Multiple choices of number of numerics, resolution and duration depending on trend option and application area. For example: For neonatal, you can choose between 12 and 16 numerics.
Alarm signal	System alarm delay	less than 4 seconds
	Pause duration	1,2,3 minutes or infinite, depending on configuration
	Extended alarm pause	5 or 10 minutes
Review Alarms	Information	all alarms / inops, main alarms on/off, alarm silence and time of occurrence
	Capacity	300 items
Real Time Clock	Range	from: January 1, 1997, 00:00 to: December 31, 2080, 23:59
	Accuracy	<4 seconds per day (typically)
	Hold Time	infinite if powered by host monitor or external power supply; otherwise at least 48 hours

X2 (M3002A) Performance Specifications		
Buffered Memory	Hold Time	if powered by host monitor or external power supply: infinite without power: at least 48 hours (typical: >72 hours)
	Contents	Active settings, trends, patient data, realtime reports, review alarms

M8023A External Power Supply Performance Specifications

M8023A External Power Supply (for M3002A) Performance Specifications		
Power Specifications	Power consumption	<12 W average <30 W peak
	Line Voltage	100 to 240 V ~
	Current	1.3 to 0.7 A
	Frequency	50/60 Hz
Indicators	Power	green LED

MMS M3001A Performance Specifications

M3001A MMS Performance Specifications		
Trends	Trend Data Buffered Memory	if powered by monitor mains connection via MSL: infinite without power applied: at least 6 hours
	Contents	trend data, patient identification and all active settings

Integrated PC (iPC)

Integrated PC (iPC) Performance Specifications		
PC Components	Processor	Intel Core 2 Duo SP9300/SP9400
	Solid-state drive	100 GB or above
	RAM	4 GB

865244 Remote Control

865244 Remote Control Performance Specifications	
Power (when not connected to the USB interface of the monitor)	Two AA primary cells

Interface Specifications

MX400/450/500/550/600/700/800 Interface Specifications

MX400/450/500/550/600/700/800		
Network	Standard	100-Base-TX (IEEE 802.3 Clause 25)
	Connector	RJ45 (8 pin)
	Isolation	basic insulation (reference voltage: 250 V; test voltage: 1500 V)
MIB/RS232	Standard	IEEE 1073-3.2-2000
	Connectors	RJ45 (8 pin)
	Mode	Software-controllable BCC (Rx/D/TxD cross over) or DCC (Rx/D/TxD straight through) not available for the advanced system interface MX400/450/500/550
	Power	5 V \pm 5 %, 100 mA (max.)
	Isolation	basic insulation (reference voltage: 250 V; test voltage: 1500 V)
USB Interface	Standard	USB 2.0 full-speed (embedded host)
	Connector	USB series "Standard A" receptacle
	Power	Low power port 4.4V min; max. load for all ports together 500 mA
	Isolation	none
RS232 (Standard)	Connector	RJ45 (8-pin)
	Power	none
	Isolation	basic insulation (reference voltage: 250 V; test voltage: 1500 V)
RS232 (Independent display interface option)	Connector	RJ45 (8-pin)
	Power	none
	Isolation	none
Basic Nurse Call Relay	Connector	modular Jack 6P6C, active open and closed contact
	Contact	\leq 100 mA, \leq 24 V DC
	Isolation	basic insulation (reference voltage: 250 V; test voltage: 1500 V)
	Delay	$<$ [Configured Latency +0.5] sec
Flexible Nurse Call Relay	Connector	20 pin MDR (Mini D-Ribbon), active open and closed contacts
	Contact	\leq 100 mA, \leq 24 V DC
	Isolation	basic insulation (reference voltage: 250 V; test voltage: 1500 V)
	Delay	$<$ [Configured Latency +0.5] sec
IntelliBridge EC10 Interface board	Connector	RJ45 (8-pin)
	Speed	1200 Bd, 2400 Bd, 4800 Bd, 9600 Bd, 19200 Bd, 38400 Bd, 57600 Bd, or 115200 Bd signaling speed
	Character bits	5-8
	Stop bits	1 or 2
	Parity	Even or odd parity generation and checking
	Power	5 V \pm 5 % @ 0-100 mA
	Isolation	double insulation (reference voltage: 250 V; test voltage: 4000 V)

MX400/450/500/550/600/700/800		
IntelliVue Instrument Telemetry Wireless Network (USA only)	Type	Internal WMTS Adapter
	Technology	compatible with Philips IntelliVue Telemetry System (ITS), cellular infrastructure
	Frequency Band	WMTS, 1395-1400 MHz and 1427-1432 MHz
IntelliVue Instrument Telemetry Wireless Network (except USA)	Type	Internal ISM Adapter
	Technology	compatible with Philips IntelliVue Telemetry System (ITS), cellular infrastructure
	Frequency Band	2.4 GHz ISM
IntelliVue 802.11 Bedside Adapter (Wireless Network Adapter)	Type	Internal Wireless Adapter
	Technology	IEEE 802.11a/b/g
	Frequency Band	2.4 GHz and 5 GHz Band
	Modulation technique	DSSS (CCK, DQPSK, DBPSK), OFDM (BPSK, QPSK, 16-QAM, 64-QAM)
	Effective radiated power (max.)	MX400-MX550: 16 dBm (35 mW) MX600-MX800: 17 dBm (50 mW)
Short Range Radio Interface	Type	Internal SRR interface
	Technology	IEEE 802.15.4
	Frequency band	2.4 GHz ISM (2.400 - 2.483 GHz)
	Modulation technique	DSSS (O -QPSK)
	Effective radiated power	max. 0 dBm (1 mW)
Measurement Link (MSL) MX600/700/800	Connectors	ODU out (Proprietary)
	Voltage	56 V \pm 10 %
	Power	45 W
	Power Sync.	5 V CMOS Level; 78.125 kHz (typ.)
	LAN signals	IEEE 802.3 10-Base-T compliant
	Serial signals	RS-422 compliant
Measurement Link (MSL) MX400/450/500/550	Connectors	ODU out (Proprietary)
	Voltage	48 V \pm 10 %
	Power	12 W
	Power Sync.	5 V CMOS Level; 78.125 kHz (typ.)
	LAN signals	IEEE 802.3 10-Base-T compliant
	Serial signals	RS-422 compliant
Video Interface (standard)	Connector	DVI (digital and analog, single link)
	Digital video signals	single link TMDS
	Analog video signals	0.7 Vpp@75 Ω
	HSYNC/VSYNC signals	TTL
	DDC signals	none (except for MX400/450/500/550)
	DDC power	5 V \pm 5% @0-55 mA

40 Specifications

MX400/450/500/550/600/700/800		
Video Interface (Independent display interface option)	Connector	DVI (digital and analog, single link)
	Pixel clock frequency	31.5 MHz - 119 MHz
	Digital video signals	single link TMDS
	Analog video signals	0.7 V _{pp} @75 Ω
	HSYNC/VSYNC signals	TTL
	DDC signals	none
	DDC power	5 V +/-5% @0-55 mA
ECG Sync Output/Analog ECG Output (1/4" stereo phone jack with tip, ring, sleeve)		
General	Connector	1/4" phone with tip, ring, sleeve
	Isolation	functional isolation
Analog ECG Output (ring, tip)	Full scale on display	signal gain x measured ECG voltage
	Gain error	<15 %
	Baseline offset	<100 mV
	Bandwidth	1 to 100 Hz
	Output voltage swing	±4 V (min)
	Signal delay	<22 ms
	Signal delay with older versions of the M3001A MMS [identifiable with the serial number prefix DE227 or DE441 and option string #A01]	<30 ms
Pacemaker Pulse	filtered and included in ECG output signal	
Digital Pulse Output (ring)	Output low voltage level	<0.4 V @ I=-1 mA
	Output high voltage level	>2.4 V @ I=1 mA
	Pulse Width	100 ms±10 ms (active high)
	Pulse Rise Time	<1 ms (from 0.4 V to 2.4 V)
	Signal delay	<25ms per AAMI EC13
	Signal delay with older versions of the M3001A MMS [identifiable with the serial number prefix DE227 or DE441 and option string #A01]	<35ms per AAMI EC13

X2 Interface Specifications

X2 (M3002A) Interface Specifications		
Measurement Link (MSL)	Connectors	Female ODU (Proprietary)
	Power	30 V to 60 V input
	Power Sync.	RS-422 compliant input 78.125 kHz (typical)
	LAN signals	IEEE 802.3 10-Base-T compliant
	Serial signals	RS-422 compliant
	Local signals	Provided for connecting MMS extensions
ECG Sync Pulse Output (rectangular pulse)	Cable detection	Yes
	Marker In	No
	Wave Output	No
	Connector	Binder Series 709/719
	Output levels	Output low <0.8 V @ I = -4 mA
		Output high >2.4 V @ I = 4 mA
	Isolation	None
	Pulse Width	100 +/- 10 ms (high)
	Delay from R-wave peak to start of pulse	20 ms maximum per AAMI EC13
Minimum required R-wave amplitude	0.5 V	
Wireless Network Device Interface	Signals	RD+/-, TD+/-: IEEE 802.3 10Base-T, PWR, GND 12.5 V ±20%, 3.5 W continuous
Short Range Radio Interface ¹	Type	Internal SRR interface
	Technology	IEEE 802.15.4
	Frequency Band	2.4 GHz ISM (2.400 - 2.483 GHz)
	Modulation Technique	DSSS (O -QPSK)
	Effective radiated power	max. 0 dBm (1 mW)

¹ The short range radio interface is compatible with the following devices: TRx4841A/TRx4851A Intellivue Telemetry System Transceiver and MX40 Wearable Patient Monitor

M8023A External Power Supply Interface Specifications

M8023A External Power Supply (for M3002A) Interface Specifications		
Measurement Link (MSL)	Connectors	Male ODU (Proprietary)
	Power	48 V output
	Power Sync.	RS-422 compliant output 78.125 kHz (typical)
	LAN signals	IEEE 802.3 10-Base-T compliant
	Serial signals	RS-422 compliant output 78.125 kHz (typical)
	Local signals	Not connected

Integrated PC (iPC) Interface Specifications

Integrated PC (iPC)		
Ethernet LAN (external)	Connector	RJ-45
	LAN Signals	IEEE 802.3 1000-Base-T compliant
	Reinforced insulation	IEC 60601-1 A-k compliant
USB	6 external ports (5 rear, 1 right side) Type A connectors	USB 2.0 supporting high speed mode
Audio	microphone input stereo	3.5 mm audio jack
	headphone output stereo	3.5 mm audio jack
DVI Video with DVI-I connector	DVI	supports resolutions up to 1920x1200
	VGA	supports resolutions up to 2048x1536

Display Specifications

Display Specifications		
19" WSXGA+ MX600/700/800	Type	482 mm active matrix color LCD (TFT)
	Resolution	1680 x 1050 (WSXGA+)
	Refresh frequency	58 Hz
	Useful screen	409.5 mm x 255.9 mm
	Pixel size	0.244 mm x 0.244 mm
15" WXGA MX550/600/700/800	Type	390 mm active matrix color LCD (TFT)
	Resolution	1280 x 768 (WXGA)
	Refresh frequency	59.9 Hz
	Useful screen	334.1 mm x 200.5 mm
	Pixel size	0.261 mm x 0.261 mm
12" WXGA (16:10) MX450/500	Type	310 mm active matrix color LCD (TFT)
	Resolution	1280 x 800 (WXGA 16:10)
	Refresh frequency	59.9 Hz
	Useful screen	261.1 mm x 163.2 mm
	Pixel size	0.204 mm x 0.204 mm
9" WVGA MX400	Type	230 mm active matrix color LCD (TFT)
	Resolution	800 x 400 (WVGA)
	Refresh frequency	60 Hz
	Useful screen	196.8 mm x 118.1 mm
	Pixel size	0.246 mm x 0.246 mm

Compatible Devices

Compatible Devices		
Displays (must be approved for medical use)		
	M8031B	XGA color 15" LCD touchscreen
	M8033C	SXGA color 17" LCD touchscreen
	865299	SXGA color 19" LCD touchscreen

M4605A Battery Specifications

The battery lifetime is 3 years from manufacturing date or 500 charge/discharge cycles.

M4605A Battery Specifications	
Physical Specifications	
W x D x H	149 mm (5.866 in) x 89 mm (3.504 in) x 19.8 mm (0.78 in)
Weight	490 g (1.08 lb) per battery
Performance Specifications	
Nominal Voltage	10.8 Volt
Rated Capacity at discharge C/5	6000 mAh
Continuous Discharge Capability	6.5 A
Environmental Specifications	
Temperature Range	Discharge 0 to 50°C (32 to 122°F) Charge 0 to 50°C (32 to 122°F) Storage and Transportation: -20 to 65°C (-4 to 140°F)
Humidity Range	Operating: 15% to 95% Relative Humidity (RH) Storage and Transportation: 5 % to 95 % Relative Humidity (RH)
Battery Type	Smart Battery 10.8 V, 6000 mAh, Lithium Ion
Safety	complies with UL 2054
Electromagnetic Compatibility (EMC)	complies with the requirements for FCC Type B computing Device, and EN 61000-4-2 and EN 61000-3-2
Communication Standard	complies with the SMBus specification v 1.1

Measurement Specifications

See the Appendix on Default Settings for a list of the settings the monitor is initially shipped with.

ECG/Arrhythmia/ST/QT

Complies with IEC 60601-2-25:1993 + A1:1999 /EN 60601-2-25:1995 + A1:1999, IEC 60601-2-27:2005/EN 60601-2-27:2006, IEC 60601-2-51:2003 /EN 60601-2-51:2003 and AAMI EC11/EC13:1991/2002.

40 Specifications

ECG/Arrhythmia/ST Performance Specifications		
Cardiotach	Range	Adult/pedi: 15 to 300 bpm Neo range: 15 to 350 bpm Note: for rates equal to or less than 15 bpm, the displayed heart rate is 0.
	Accuracy	±1% of range
	Resolution	1 bpm
	Sensitivity	≥200 μV _{peak}
PVC Rate	Range	0 to 300 bpm
	Resolution	1 bpm
ST Numeric	Range	-20 to +20 mm
	Accuracy	±0.5 mm or 15%, whichever is greater
	Resolution	0.1 mm
QT Numeric	Range	200 to 800 ms
	Accuracy	±30 ms
	Resolution	8 ms
QTc Numeric	Range	200 to 800 ms
	Resolution	1 ms
ΔQTc Numeric	Range	-600 to +600 ms
	Resolution	1 ms
QT-HR Numeric	Range - adult	15 to 150 bpm
	Range - pediatric and neonatal	15 to 180 bpm
Sinus and SV Rhythm Ranges	Brady	Adult: 15 to 59 bpm Pedi: 15 to 79 bpm Neo: 15 to 89 bpm
	Normal	Adult: 60 to 100 bpm Pedi: 80 to 160 bpm Neo: 90 to 180 bpm
	Tachy	Adult: >100 bpm Pedi: >160 bpm Neo: >180 bpm
Bandwidth	Diagnostic Mode	Adult/neo/pedi: 0.05 to 150 Hz
	Extended Monitoring Mode	Adult/neo/pedi: 0.5 to 150 Hz
	Monitoring Mode	Adult: 0.5 to 40 Hz Neo/pedi: 0.5 to 55 Hz
	Filter Mode	Adult/neo/pedi: 0.5 to 20 Hz
Bandwidth when the ECG is transmitted from a telemetry device via short range radio	Diagnostic Mode	Adult/neo/pedi: 0.05 to 40 Hz
	Extended Monitoring Mode	Adult/neo/pedi: 0.5 to 40 Hz
	Monitoring Mode	Adult: 0.5 to 40 Hz Neo/pedi: 0.5 to 40 Hz
	Filter Mode	Adult/neo/pedi: 0.5 to 20 Hz
Differential Input Impedance		>2 MΩ RA-LL leads (Resp) >5 MΩ at all other leads (at 10 Hz including patient cable)
Common Mode Rejection Ratio		Diagnostic mode: >86 dB (with a 51 kΩ/47 nF imbalance). Filter mode: >106 dB (with a 51 kΩ/47 nF imbalance).
Electrode Offset Potential Tolerance		±500 mV

ECG/Arrhythmia/ST Performance Specifications	
Auxiliary Current (Leads off Detection)	Active electrode: <100 nA Reference electrode: <900 nA
Input Signal Range	±5 mV

ECG/Arrhythmia/ST/QT Alarm Specifications	Range	Adjustment
HR	15 to 300 bpm maximum delay: 10 seconds according to AAMI EC 13-1992 standard	Adult:1 bpm steps (15 to 40 bpm) 5 bpm steps (40 to 300 bpm) Pedi/Neo:1 bpm steps (15 to 50 bpm) 5 bpm steps (50 to 300 bpm)
Extreme Tachy	Difference to high limit 0 to 50 bpm	5 bpm steps
	Clamping at 150 to 300 bpm	5 bpm steps
Extreme Brady	Difference to low limit 0 to 50 bpm	5 bpm steps
	Clamping at 15 to 100 bpm	5 bpm steps
Run PVCs	None, fixed setting 2 PVCs	Not adjustable by user
PVCs Rate	1 to 99 PVCs/minute	1 PVC
Vent Tach HR	20 to 300 bpm	5 bpm
Vent Tach Run	3 to 99 PVCs/minute	1 PVC
Vent Rhythm Run	3 to 99 PVCs/minute	1 PVC
SVT HR	120 to 300 bpm	5 bpm
SVT Run	3 to 99 SV beats	1 SV beat
ST High	-19.8 to +20 mm	0.2 mm
ST Low	-20 to +19.8 mm	0.2 mm
STE Limit	-20 to +20 mm	0.2 mm
QTc High	200 ms to 800 ms	10 ms steps
ΔQTc High	30 ms to 200 ms	10 ms steps

ECG/Arrhythmia/ST Supplemental Information as required by AAMI EC11/13, IEC 60601-2-27		
Respiration Excitation Waveform	Sinusoidal signal, 260 μA, 40.5 kHz	
Noise Suppression	RL drive gain 44 dB max., max. voltage 1.8 Vrms	
Time to Alarm for Tachycardia	Vent Tachycardia 1 mV _{pp} , 206 bpm	Gain 0.5, Range 6.5 to 8.4 seconds, Average 7.2 seconds
		Gain 1.0 Range 6.1 to 6.9 seconds, Average 6.5 seconds
		Gain 2.0, Range 5.9 to 6.7 seconds, Average 6.3 seconds
	Vent Tachycardia 2 mV _{pp} , 195 bpm	Gain 0.5, Range 5.4 to 6.2 seconds, Average 5.8 seconds
		Gain 1.0, Range 5.7 to 6.5 seconds, Average 6.1 seconds
		Gain 2.0, Range 5.3 to 6.1 seconds, Average 5.7 seconds
Tall T-Wave Rejection Capability	Exceeds ANSI/AAMI EC 13 Sect. 3.1.2.1(c) minimum recommended 1.2 mV T-Wave amplitude	

40 Specifications

ECG/Arrhythmia/ST Supplemental Information as required by AAMI EC11/13, IEC 60601-2-27	
Heart Rate Averaging Method	Three different methods are used: Normally, heart rate is computed by averaging the 12 most recent RR intervals. For runs of PVCs, up to 8 RR intervals are averaged to compute the HR. If each of 3 consecutive RR intervals is greater than 1200 ms (that is, rate less than 50 bpm), then the 4 most recent RR intervals are averaged to compute the HR.
Response Time of Heart Rate Meter to Change in Heart Rate	HR change from 80 to 120 bpm: Range: [6.4 to 7.2 seconds] Average: 6.8 seconds HR change from 80 to 40 bpm: Range: [5.6 to 6.4 sec] Average: 6.0 seconds
Heart Rate Meter Accuracy and Response to Irregular Rhythm	Ventricular bigeminy: 80 bpm Slow alternating ventricular bigeminy: 60 bpm Rapid alternating ventricular bigeminy: 120 bpm Bidirectional systoles: 90 bpm
Accuracy of Input Signal Reproduction	Methods A and D were used to establish overall system error and frequency response.
Pacemaker Pulse Rejection Performance	Rejection of pacemaker pulses with amplitudes from ± 2 mV to ± 700 mV and widths from 0.1 ms to 2.0 ms (Method A)
Pacemaker Pulse Rejection of fast ECG signals	2.2 V/s RTI (Paced Mode)
Minimum input slew rate	2.2 V/s RTI

Respiration

Respiration Performance Specifications		
Respiration Rate	Range	Adult/pedi: 0 to 120 rpm Neo: 0 to 170 rpm
	Accuracy	at 0 to 120 rpm ± 1 rpm at 120 to 170 rpm ± 2 rpm
	Resolution	1 rpm
Bandwidth	0.3 to 2.5 Hz (-6 dB)	
Noise	Less than 25 m Ω (rms) referred to the input	

Respiration Alarm Specifications	Range	Adjustment	Delay
High	Adult/pedi: 10 to 100 rpm Neo: 30 to 150 rpm	under 20 rpm: 1 rpm steps over 20 rpm: 5 rpm steps	max. 14 seconds
Low	Adult/pedi: 0 to 95 rpm Neo: 0 to 145 rpm	under 20 rpm: 1 rpm steps over 20 rpm: 5 rpm steps	for limits from 0 to 20 rpm: max. 4 seconds for limits above 20 rpm: max. 14 seconds
Apnea Alarm	10 to 40 seconds	5 second steps	

SpO₂

Unless otherwise specified, this information is valid for SpO₂ measured using the M3001A and M3002A Multi-measurement modules and the M1020B measurement module. The SpO₂ Performance Specifications in this section apply to devices with Philips SpO₂ technology. For SpO₂ Performance Specifications valid for other SpO₂ technologies, refer to the instructions for use provided with these devices.

Complies with ISO 9919:2005 / EN ISO 9919:2009 (except alarm system; alarm system complies with IEC 60601-2-49:2001).

Measurement Validation: The SpO₂ accuracy has been validated in human studies against arterial blood sample reference measured with a CO-oximeter. Pulse oximeter measurements are statistically distributed, only about two-thirds of the measurements can be expected to fall within the specified accuracy compared to CO-oximeter measurements.

Display Update Period: Typical: 2 seconds, Maximum: 30 seconds. Maximum with NBP INOP suppression on: 60 seconds.

SpO ₂ Performance Specifications		
SpO₂ The specified accuracy is the root-mean-square (RMS) difference between the measured values and the reference values	Range	0 to 100%
	Option #A01 Accuracy	Philips Reusable Sensors: M1191A, M1191AL, M1191B, M1191BL, M1192A = 2 % (70 % to 100 %) M1193A, M1194A, M1195A, M1196A, M1196S = 3 % (70 % to 100 %) M1191T, M1192T, M1193T (Adult), M1196T = 3% (70% to 100%) M1193T (Neonate) = 4 % (70% to 100%) Philips Disposable Sensors with M1943A(L): M1132A, M1133A (adult/infant), M1134A (adult/infant) = 2 % M1901B, M1902B, M1903B, M1904B, M1131A, M1133A (neonate), M1134A (neonate) = 3 % (70% to 100%) NellcorPB[®] Sensors with M1943A(L): MAXA, MAXAL, MAXP, MAXI, MAXN, D-25, D-20, I-20, N-25, Oxicliq A, P, I, N = 3 % (70% to 100%) Masimo Reusable Sensors[®] with LNOP MP12 or LNC MP10: LNOP DC-I, LNOP DC-IP, LNOP YI (adult/pedi/infant), LNCS DC-1, LNCS DC-IP, LNCS YI (adult/pedi/infant) = 2% (70% to 100%) LNOP YI (neonate), LNCS YI (neonate) = 3% (70% to 100%) LNOP TC-I, LNCS TC-I: 3.5 % (70% to 100%) Masimo Disposable Sensors[®] with LNOP MP12 or LNC MP10: LNOP Adt, LNOP Adtx, LNOP Pdt, LNOP Pdtx, LNOP Inf-L, LNOP Neo-L (adult), LNCS Adtx, LNCS Adtx-3, LNCS Pdtx, LNCS Pdtx-3, LNCS Inf, LNCS Inf-3, LNCS Neo (adult), LNCS Neo-3 (adult) = 2% (70% to 100%) LNOP Neo-L (neonate), LNOP NeoPt-L, LNCS Neo (neonate), LNCS Neo-3 (neonate), LNCS NeoPt, LNCS NeoPt-3 = 3% (70% to 100%)
	Option #A02 Accuracy	Philips Reusable Sensors M1193AN = 3 % (70% to 100%) Philips Disposable Sensors with M1943NL: M1901B (Adult), M1902B, M1903B, M1904B = 2% (70% to 100%) M1901B (Neonate) = 3% Nellcor Sensors with M1943NL: MAXFAST, MAXA, MAXAL, MAXP, MAXI, MAXN (Adult) = 2 % (70 % to 100 %) SC-A, Oxicliq A, P, I, N (Adult) = 2.5% (70% to 100%) MAXN (Neonate), Dura-Y D-YS (Infant to Adult), DS-100A-1, Oxiband OXI-A/N (Adult), OXI-P/I = 3 % (70% to 100%) MAXR, Oxicliq N (Neonate), SCNEO-I (Neonate), SC-PR-I (Neonate), Dura-Y D-YS with D-YSE or D-YSPD clip = 3.5 % (70% to 100%) Dura-Y D-YS (Neonate), Oxiband OXI-A/N (Neonate) = 4% (70% to 100%)
	Resolution	1%
	Averaging Time	5, 10 or 20 seconds (user adjustable)
Pulse	Range	30 to 300 bpm
	Accuracy	±2% or 1 bpm, whichever is greater
	Resolution	1 bpm
Sensors		Wavelength range: 500 to 1000 nm Emitted Light Energy: ≤15 mW Information about the wavelength range can be especially useful to clinicians (for instance, when photodynamic therapy is performed)

SpO ₂ Performance Specifications		
Pulse Oximeter Calibration Range		70% to 100%

SpO ₂ Alarm Specifications	Range	Adjustment
SpO ₂ high and low limit alarms	Adult: 50 to 100% Pedi/Neo: 30 to 100%	1% steps
Desat	Adult: 50% to Low alarm limit Pedi/Neo: 30% to Low alarm limit	1% steps
Pulse	30 to 300 bpm	Adult: 1 bpm steps (30 to 40 bpm) 5 bpm steps (40 to 300 bpm) Pedi/Neo: 1 bpm steps (30 to 50 bpm) 5 bpm steps (50 to 300 bpm)
Tachycardia	Difference to high limit 0 to 50 bpm	5 bpm steps
	Clamping at 150 to 300 bpm	5 bpm steps
Bradycardia	Difference to low limit 0 to 50 bpm	5 bpm steps
	Clamping at 30 to 100 bpm	5 bpm steps

SpO ₂ Alarm Specifications (cont.)	Standard Delay	Smart Alarm Delay (alternative to standard alarm delay)		
		Short Mode	Medium mode	Long Mode
SpO ₂ high and low limit alarms	0 to 30 seconds (adjustable in 1 second steps) + system alarm delay ¹	10 to 25 seconds + system alarm delay	10 to 50 seconds + system alarm delay	10 to 100 seconds + system alarm delay
Desat	0 to 30 seconds (adjustable in 1 second steps) + system alarm delay	not supported		
Pulse	10 seconds + system alarm delay			
Tachycardia	10 seconds + system alarm delay			
Bradycardia	10 seconds + system alarm delay			

1. Refer to "Monitor Performance Specifications" on page 464 for system alarm delay specification.

SpO ₂ Smart Alarm Delay - Detailed Specifications			
Deviation from violated alarm limit	Resulting alarm delay according to selected mode		
	Short	Medium	Long
1%	25 sec (maximum delay)	50 sec (maximum delay)	100 sec (maximum delay)
2%	12 sec	25 sec	50 sec
3%	10 sec	16 sec	33 sec
4%	10 sec	12 sec	25 sec
5%	10 sec	10 sec	20 sec
6%	10 sec	10 sec	16 sec
7%	10 sec	10 sec	14 sec
8%	10 sec	10 sec	12 sec

40 Specifications

SpO ₂ Smart Alarm Delay - Detailed Specifications			
Deviation from violated alarm limit	Resulting alarm delay according to selected mode		
	Short	Medium	Long
9%	10 sec	10 sec	11 sec
>9%	10 sec	10 sec	10 sec

NBP

Complies with IEC 60601-2-30:1999/EN 60601-2-30:2000.

NBP Performance Specifications	
Measurement Ranges	Systolic Adult: 30 to 270 mmHg (4 to 36 kPa) Pedi: 30 to 180 mmHg (4 to 24 kPa) Neo: 30 to 130 mmHg (4 to 17 kPa)
	Diastolic Adult: 10 to 245 mmHg (1.5 to 32 kPa) Pedi: 10 to 150 mmHg (1.5 to 20 kPa) Neo: 10 to 100 mmHg (1.5 to 13 kPa)
	Mean Adult: 20 to 255 mmHg (2.5 to 34 kPa) Pedi: 20 to 160 mmHg (2.5 to 21 kPa) Neo: 20 to 120 mmHg (2.5 to 16 kPa)
	Pulse Rate Adult: 40 to 300 bpm Pedi: 40 to 300 bpm Neo: 40 to 300 bpm
Accuracy	Max. Std. Deviation: 8 mmHg (1.1 kPa) Max. Mean Error: ± 5 mmHg (± 0.7 kPa)
Pulse Rate Measurement Accuracy	40 to 100 bpm: ± 5 bpm 101 to 200 bpm: $\pm 5\%$ of reading 201 to 300 bpm: $\pm 10\%$ of reading (average over NBP measurement cycle)
Pulse Rate Range	40 to 300 bpm
Measurement Time	Typical at HR >60 bpm Auto/manual/sequence: Adult: 30 seconds Neonatal: 25 seconds Stat: 20 seconds Maximum time: Adult/pedi: 180 seconds Neo: 90 seconds
Cuff Inflation Time	Typical for normal adult cuff: Less than 10 seconds Typical for neonatal cuff: Less than 2 seconds
Initial Cuff Inflation Pressure	Adult: 165 ± 15 mmHg Pedi: 130 ± 15 mmHg Neo: 100 ± 15 mmHg
Maximum Cuff Pressure	Adult/Pedi: 300 mmHg Neo: 150 mmHg
Auto Mode Repetition Times	1 min, 2 min, 2.5 min, 3 min, 10 min, 15 min, 20 min, 30 min, 45 min, 1h, 2h, 4h, 8h, 12h, 24h
STAT Mode Cycle Time	5 minutes

NBP Performance Specifications		
Venipuncture Mode Inflation		
Inflation Pressure	Adult	20 to 120 mmHg (3 to 16 kPa)
	Pediatric	20 to 80 mmHg (3 to 11 kPa)
	Neonatal	20 to 50 mmHg (3 to 7 kPa)
Automatic deflation after	Adult/pediatric	170 seconds
	Neonatal	85 seconds

Measurement Validation: In adult and pediatric mode, the blood pressure measurements determined with this device comply with the American National Standard for Electronic or Automated Sphygmomanometers (ANSI/AAMI SP10 - 1992) in relation to mean error and standard deviation, when compared to intra-arterial or auscultatory measurements (depending on the configuration) in a representative patient population. For the auscultatory reference the 5th Korotkoff sound was used to determine the diastolic pressure.

In neonatal mode, the blood pressure measurements determined with this device comply with the American National Standard for Electronic or Automated Sphygmomanometers (ANSI/AAMI SP10 - 1992 and AAMI/ANSI SP10A -1996) in relation to mean error and standard deviation, when compared to intra-arterial measurements in a representative patient population.

NBP Alarm Specifications	Range	Adjustment
Systolic	Adult: 30 to 270 mmHg (4 to 36 kPa)	10 to 30 mmHg: 2 mmHg (0.5 kPa) >30 mmHg: 5 mmHg (1 kPa)
	Pedi: 30 to 180 mmHg (4 to 24 kPa)	
	Neo: 30 to 130 mmHg (4 to 17 kPa)	
Diastolic	Adult: 10 to 245 mmHg (1.5 to 32 kPa)	
	Pedi: 10 to 150 mmHg (1.5 to 20 kPa)	
	Neo: 10 to 100 mmHg (1.5 to 13 kPa)	
Mean	Adult: 20 to 255 mmHg (2.5 to 34 kPa)	
	Pedi: 20 to 160 mmHg (2.5 to 21 kPa)	
	Neo: 20 to 120 mmHg (2.5 to 16 kPa)	

NBP Overpressure Settings		
Adult	>300 mmHg (40 kPa) >2 sec	not user adjustable
Pediatric	>300 mmHg (40 kPa) >2 sec	
Neonate	>150 mmHg (20 kPa) >2 sec	

Invasive Pressure and Pulse

Complies with IEC 60601-2-34:2000/EN 60601-2-34:2000.

Invasive Pressure Performance Specifications		
Measurement Range		-40 to 360 mmHg
Pulse Rate	Range	25 to 350 bpm
	Accuracy	±1% Full Range
	Resolution	1 bpm

40 Specifications

Invasive Pressure Performance Specifications		
Input Sensitivity		Sensitivity: 5 $\mu\text{V}/\text{V}/\text{mmHg}$ (37.5 $\mu\text{V}/\text{V}/\text{kPa}$) Adjustment range: $\pm 10\%$
Transducer		Load Impedance: 200 to 2000 Ω (resistive) Output Impedance: $\leq 3000 \Omega$ (resistive)
Frequency Response		dc to 12.5 Hz or 40 Hz
Zero Adjustment	Range	$\pm 200 \text{ mmHg}$ ($\pm 26 \text{ kPa}$)
	Accuracy	$\pm 1 \text{ mmHg}$ ($\pm 0.1 \text{ kPa}$)
	Drift	Less than 0.1 mmHg/ $^{\circ}\text{C}$ (0.013 kPa/ $^{\circ}\text{C}$)
Gain Accuracy	Accuracy	$\pm 1\%$
	Drift	Less than 0.05%/ $^{\circ}\text{C}$
	Non linearity and Hysteresis	Error of $\leq 0.4\% \text{ FS}$ (@CAL 200 mmHg)
Overall Accuracy	(including transducer)	$\pm 4\%$ of reading or $\pm 4 \text{ mmHg}$ ($\pm 0.5 \text{ kPa}$), whichever is greater
Volume displacement of CPJ840J6		0.1 mm ³ / 100 mmHg

Analog output Specifications		
Analog Output available only with M1006B #C01 (@ CAL 200 mmHg)	Range	-0.4 V to 3.6 V
	Level	1 V / 100 mmHg
	Accuracy	$\pm 3\%$ full scale
	Offset	$\pm 30 \text{ mV}$
	Resolution	8 Bit (@ 5 V range)
	Signal delay	20 ms

Invasive Pressure Alarm Specifications

Invasive Pressure Alarm Specifications	Range	Adjustment	Delay
Pressure	-40 to 360 mmHg (-5.0 to 48 kPa)	-40 to 50 mmHg 2 mmHg (0.5 kPa) >50 mmHg 5 mmHg (1 kPa)	max. 12 seconds
Extreme High	Difference to high limit 0 to 25 mmHg	5 mmHg steps (0.5 kPa)	
	Clamping at -40 to 360 mmHg	5 mmHg steps (1.0 kPa)	
Extreme Low	Difference to low limit 0 to 25 mmHg	5 mmHg steps (0.5 kPa)	
	Clamping at -40 to 360 mmHg	5 mmHg steps (1.0 kPa)	
Pulse	25 to 300 bpm	Adult: 1 bpm steps (25 to 40 bpm) 5 bpm steps (40 to 300 bpm) Pedi/Neo: 1 bpm steps (25 to 50 bpm) 5 bpm steps (50 to 300 bpm)	
Tachycardia	Difference to high limit 0 to 50 bpm	5 bpm steps	max. 14 seconds
	Clamping at 150 to 300 bpm	5 bpm steps	

Invasive Pressure Alarm Specifications	Range	Adjustment	Delay
Bradycardia	Difference to low limit 0 to 50 bpm	5 bpm steps	max. 14 seconds
	Clamping at 25 to 100 bpm	5 bpm steps	

Temp

Complies with EN 12470-4:2000 and IEC 60601-2-49:2001. Specified without transducer.

Temp Performance Specifications		
Temp	Range	-1 to 45°C (30 to 113°F)
	Resolution	0.1°C (0.2°F)
	Accuracy	±0.1°C (±0.2°F)
Average Time Constant		Less than 10 seconds

Temp Alarm Specifications	Range	Adjustment
Temp High/Low Alarms	-1 to 45°C (30 to 113°F)	-1 to 35°C (30 to 95°F), 0.5°C (1.0°F) steps 35 to 45°C (95 to 113°F), 0.1°C (0.2°F) steps

CO₂

The CO₂ measurement in M3014A and M3015A/B complies with EN ISO 21647:2004 + Cor.1:2005 (except alarm system; alarm system complies with IEC 60601-2-49:2001).

M3015A Microstream CO ₂ Performance Specifications		
CO ₂	Range	0 to 150 mmHg (0 to 20 kPa), or 20% CO ₂ , whichever is lower
	Accuracy	Up to 5 minutes during warmup: ±4 mmHg or 12%, whichever is greater After 5 minutes warmup: 0 to 40 mmHg (0 to 5.3 kPa): ±2.2 mmHg (±0.3 kPa) Above 40 mmHg (5.3 kPa): ±(5.5% + {0.08% per mmHg above 40 mmHg}) of reading These specifications are valid for 21% O ₂ and N ₂ balance, up to 35°C ambient temperature, up to 60 rpm in adult mode and 100 rpm in neonatal mode. Outside of these conditions the accuracy reaches at a minimum ±4 mmHg or ±12% of the reading, whichever is greater.
	Resolution	Numeric: 1.0 mmHg (0.1 kPa) Wave: 0.1 mmHg (0.01 kPa)
	Stability	Included in Accuracy specifications
AwRR	Range	0 to 150 rpm
	Accuracy	0 to 40 rpm: ±1 rpm 41 to 70 rpm: ±2 rpm 71 to 100 rpm: ±3 rpm >100 rpm: ±5% of reading
IPI	Range	1 to 10
	Resolution	1
Warm-up Time		5 minutes for full accuracy specification

40 Specifications

M3015A Microstream CO ₂ Performance Specifications		
Rise Time		190 ms for neonatal mode (measured with FilterLine H for neonatal) 240 ms for adult mode (measured with FilterLine H for adult)
Sample Flow Rate		50 + 15/-7.5 ml/minute
Gas Sampling Delay Time		Maximum: 3 seconds (2m sample lines) 6 seconds (4m sample lines)
Sound Pressure		Acoustic noise: <45 dBA
Total System Response Time		The total system response time is the sum of the delay time and the rise time.

Microstream CO₂ Humidity Correction Factor

Either BTPS or ATPD can be selected as the humidity correction factor for the Microstream CO₂ readings. The formula for the correction calculation is:

$$P_{\text{BTPS}} = (P_{\text{ATPD}} \cdot 0.94) \quad \text{where:}$$

P_{BTPS} = partial pressure at body temperature and pressure, saturated

P_{ATPD} = partial pressure at ambient temperature and pressure, dry

M3014A Mainstream CO ₂ Performance Specifications		
CO ₂	Range	0 to 150 mmHg (0 to 20.0 kPa)
	Accuracy	after 2 minutes warmup: For values between 0 and 40 mmHg: ± 2.0 mmHg (± 0.29 kPa) For values from 41 to 70 mmHg: $\pm 5\%$ of reading For values from 71 to 100 mmHg: $\pm 8\%$ of reading The specifications are valid for standard gas mixtures, balance air, fully hydrated at 35°C, $P_{\text{abs}} = 760$ mmHg, flow rate = 2 l/min.
	Resolution	Numeric: 1.0 mmHg (0.1 kPa) Wave: 0.1 mmHg (0.01 kPa)
	Stability:	
	Short term drift	± 0.8 mmHg over four hours
	Long term drift	Accuracy specification will be maintained over a 120 hour period
awRR	Range	2 to 150 rpm
	Accuracy	± 1 rpm
Warm-up Time		2 minutes with CO ₂ transducer attached for full accuracy specification
Response Time		Less than 60 ms (with adult or infant reusable or disposable adapter)

M3014A Sidestream CO ₂ Performance Specifications		
CO ₂	Range	0 to 150 mmHg (0 to 20.0 kPa)
	Accuracy	after 2 minutes warmup: For values between 0 and 40 mmHg: ±2.0 mmHg (±0.29 kPa) For values from 41 to 70 mmHg: ±5% of reading For values from 71 to 100 mmHg: ±8% of reading For values from 101 to 150 mmHg: ±10% of reading At respiration rates above 80 rpm, all ranges are ±12% of actual. The specifications are valid for gas mixtures of CO ₂ , balance N ₂ , dry gas at 760 mmHg within specified operating temperature range.
	Resolution	Numeric: 1.0 mmHg (0.1 kPa) Wave: 0.1 mmHg (0.01 kPa)
	Stability:	
	Short term drift	±0.8 mmHg over four hours
	Long term drift	Accuracy specification will be maintained over a 120 hour period
awRR	Range	2 to 150 rpm
	Accuracy	±1 rpm
Warm-up Time	2 minutes with CO ₂ sensor attached for full accuracy specification	
Sample Flow Rate	50 ±10 ml/minute	
Total System Response Time	3 seconds	
Operating Temperature	0 to 40°C (32 to 100°F)	

M3014A Mainstream and Sidestream CO₂ Humidity Correction Factor

Either BTPS or ATPD can be selected as the humidity correction factor for the CO₂ readings. The formula for the correction calculation is:

$$P_{ATPD} = P_{BTPS} \cdot \frac{P_{abs}}{P_{abs} - P_{H2O}}$$

where:

P_{BTPS} = partial pressure at body temperature and pressure, saturated

P_{ATPD} = partial pressure at ambient temperature and pressure, dry

P_{abs} = absolute pressure

P_{H2O} = 42 mmHg @35°C and 100% RH

M3016A Mainstream CO ₂ Performance Specifications		
CO ₂	Range	-4 to 150 mmHg (-0.5 to 20.0 kPa)
	Accuracy	after 20 minutes warmup and calibration: For values between 0 and 40 mmHg: ±2.2 mmHg (±0.29 kPa) For values between 40 and 76 mmHg: ±5.5% of reading The specifications are valid for 45% O ₂ and N ₂ or N ₂ O balance. Outside these conditions the accuracy reaches at a minimum the requirements of EN864/ISO9918.
	Resolution	Numeric: 1.0 mmHg (0.1 kPa) Wave: 0.1 mmHg (0.01 kPa)
	Stability	±1.0 mmHg over a 7 day period

40 Specifications

M3016A Mainstream CO ₂ Performance Specifications		
awRR	Range	0 to 150 rpm
	Accuracy	±2 rpm
Warm-up Time	20 minutes with CO ₂ transducer attached for full accuracy specification	
Response Time	Less than 125 ms (for step from 10% to 90%)	

Mainstream CO₂ Humidity Correction Factor

Either BTPS or ATPD can be selected as the humidity correction factor for the Mainstream CO₂ readings. The formula for the correction calculation is:

$$P_{ATPD} = P_{BTPS} \cdot \frac{P_{abs}}{P_{abs} - P_{H_2O}}$$

where:

P_{BTPS} = partial pressure at body temperature and pressure, saturated

P_{ATPD} = partial pressure at ambient temperature and pressure, dry

P_{abs} = absolute pressure

P_{H₂O} = 42 mmHg @35°C and 100% RH

CO ₂ Alarm Specifications	Range	Adjustment	Delay
etCO ₂ High	20 to 95 mmHg (2 to 13 kPa)	1 mmHg (0.1 kPa)	M3002A/M3014A/M3016A: less than 14 seconds M3015A: less than 21 seconds.
etCO ₂ Low	10 to 90 mmHg (1 to 12 kPa)		
imCO ₂ High	2 to 20 mmHg (0.3 to 3.0 kPa)	steps of 1 mmHg (0.1 kPa)	M3002A/M3014A/M3016A: less than 14 seconds M3015A: less than 21 seconds.
awRR High	Adult/pedi: 10 to 100 rpm Neo: 30 to 150 rpm	under 20 rpm: 1 rpm steps over 20 rpm: 5 rpm steps	M3002A/M3014A/M3016A: less than 14 seconds M3015A: less than 21 seconds.
awRR Low	Adult/pedi: 0 to 95 rpm Neo: 0 to 145 rpm		
IPI Low (M3015A/B only)	Adult/pedi: 2 to 9	steps of 1	Maximum 14 seconds after displayed value goes below the low alarm limit setting.
Apnea delay	10 to 40 seconds	5 second steps	set apnea delay time + 4 seconds (M3002A/M3014A/M3016A) or 8 seconds (M3015A with 2 m sample lines) or 11 seconds (M3015A with 4 m sample lines).

Interfering Gas and Vapor Effects On CO₂ Measurement Values

The specified deviations for M3002A/M3014A are valid when the appropriate corrections are switched on and set correctly.

Gas or Vapor	Gas Level (% volume fraction)	M3002A/M3014A	M3015A
		Additional deviation due to gas interference, measured at 0 - 40 mmHg CO₂	
Nitrous Oxide	60%	±1 mmHg	±5%
Halothane	4%	±2 mmHg	±5%
Enflurane	5%	±2 mmHg	±5%
Isoflurane	5%	±2 mmHg	±5%
Sevoflurane	5%	±2 mmHg	±5%
Xenon	80%	-5 mmHg	±5%
Helium	50%	±1 mmHg	±5%
Metered dose inhaler propellants	-	not specified for use	
Desflurane	15%	+5 mmHg	±5%
Ethanol	0.1%	±1 mmHg	±5%
Isopropanol	0.1%	±1 mmHg	±5%
Acetone	0.1%	±1 mmHg	±5%
Methane	1%	±1 mmHg	±5%

Spirometry

Complies with IEC 60601-2-49:2001. The following specifications apply for 760 mmHg ambient pressure and patient gas: room air at 35°C, unless otherwise noted.

Spirometry Performance Specifications		
Flow Wave (AWF)	Range	±25 l/min (neonatal) ±100 l/min (pediatric) ±180 l/min (adult)
	Accuracy	±3% or 0.125 l/min (neonatal) 0.25 l/min (pediatric) 0.5 l/min (adult)
	Scales	±10, ±20, ±40, ±60, ±80, ±100, ±120, ±150 l/min
	Scale Default	±20 l/min (neonatal) ±100 l/min (pediatric) ±150 l/min (adult)

40 Specifications

Spirometry Performance Specifications		
Volume Wave (AWV)	Range	0 to 100 ml (neonatal) 0 to 400 ml (pediatric) 0 to 3000 ml (adult)
	Accuracy	±5% or ±3 ml (neonatal) ±12 ml (pediatric) ±90 ml (adult), whichever is greater
	Scales	50, 100, 200, 600, 800, 1000, 2000, 3000 ml
	Scale Default	50 ml (neonatal) 200 ml (pediatric) 800 ml (adult)
Pressure Wave (AWP)	Range	-20 to 120 cmH ₂ O
	Accuracy	±2% or ±0.5 cmH ₂ O whichever is greater
	Scales	10, 20, 40, 60, 80, 100, 120 cmH ₂ O
	Scale Default	20 cmH ₂ O (neonatal) 40 cmH ₂ O (pediatric) 40 cmH ₂ O (adult)
Respiration Rate numeric (RR_{spir})	Range	2 to 120 breaths/min
	Resolution	1 breath/min
Inspired Minute Volume numeric (M_{Vin})	Range	0.01 to 5 l/min (neonatal) 0.06 to 30 l/min (pediatric) 0.4 to 60 l/min (adult)
	Resolution	0.01 l/min (neonatal/pediatric) 0.1 l/min (adult)
Expired Minute Volume numeric (M_{Vexp})	Range	0.01 to 5 l/min (neonatal) 0.06 to 30 l/min (pediatric) 0.4 to 60 l/min (adult)
	Resolution	0.01 l/min (neonatal/pediatric) 0.1 l/min (adult)
Inspired Volume numeric (T_{Vin})	Range	5 to 100 ml (neonatal) 30 to 400 ml (pediatric) 200 to 3000 ml (adult)
	Resolution	1 ml (neonatal/pediatric) 10 ml (adult)
Expired Volume numeric (T_{Vexp})	Range	5 to 100 ml (neonatal) 30 to 400 ml (pediatric) 200 to 3000 ml (adult)
	Resolution	1 ml (neonatal/pediatric) 10 ml (adult)
Lung Compliance numeric	Range	0 to 500 ml/cmH ₂ O
	Resolution	1 ml/cmH ₂ O
Airway Resistance numeric	Range	0 to 500 cmH ₂ O/l/s (neonatal) 0 to 250 cmH ₂ O/l/s (pediatric) 0 to 100 cmH ₂ O/l/s (adult)
	Resolution	1 cmH ₂ O/l/s
Peak Inspiratory Pressure numeric (PIP)	Range	0 to 120 cmH ₂ O
	Resolution	1 cmH ₂ O

Spirometry Performance Specifications		
Negative Inspiratory Pressure numeric	Range	-20 to 0 cmH ₂ O
	Resolution	1 cmH ₂ O
Mean Airway Pressure	Range	0 to 120 cmH ₂ O
	Resolution	1 cmH ₂ O
Plateau Pressure numeric	Range	0 to 120 cmH ₂ O
	Resolution	1 cmH ₂ O
Positive End-Expiratory Pressure numeric (PEEP)	Range	0 to 99 cmH ₂ O
	Resolution	1 cmH ₂ O
Barometric Pressure numeric (PB)	Range	400 to 800 mmHg
	Resolution	1 mmHg
Peak Inspiratory Flow numeric (PIF)	Range	0.3 to 25 l/min (neonatal) 1 to 100 l/min (pediatric) 2 to 180 l/min (adult)
	Resolution	0.1 l/min (neonatal) 1 l/min (pediatric/adult)
Peak Expiratory Flow numeric (PEF)	Range	0.3 to 25 l/min (neonatal) 1 to 100 l/min (pediatric) 2 to 180 l/min (adult)
	Resolution	0.1 l/min (neonatal) 1 l/min (pediatric/adult)
Inspiration to Expiration ratio numeric (I:E)	Range	1: 0.2 to 9.9
	Resolution	0.1

Cardiac Output / Continuous Cardiac Output

Complies with IEC 60601-2-34:2000

C.O./CCO Performance Specifications		
C.O. (right heart)	Range	0.1 to 20.0 l/min
	Accuracy	Instrument Specification (electrical): $\pm 3\%$ or 0.1 l/min System Specification: $\pm 5\%$ or 0.2 l/min
	Repeatability	Instrument Specification (electrical): $\pm 2\%$ or 0.1 l/min System Specification: $\pm 3\%$ or 0.1 l/min
C.O. (transpulmonary)	Range	0.1 to 25.0 l/min
	Accuracy	Instrument Specification (electrical): $\pm 4\%$ or 0.15 l/min System Specification: $\pm 5\%$ or 0.2 l/min
	Repeatability	Instrument Specification (electrical): $\pm 2\%$ or 0.1 l/min System Specification: $\pm 3\%$ or 0.1 l/min
EVLW	Range	10 to 5000 ml
	Standard Deviation	10% or 1 ml/kg
ITBV	Range	50 to 6000 ml
	Accuracy	$\pm 10\%$ or 30 ml
	Repeatability	$\pm 5\%$ or 20 ml

40 Specifications

C.O./CCO Performance Specifications		
CCO	Range	0.1 to 25.0 l/min
	Standard Deviation	10% or 0.3 l/min
	Display Update	2 seconds nominal
Blood Temperature	Range	17.0 to 43°C (62.6 to 109,5°F)
Injectate Temperature	Range	-1 to 30°C (30.2 to 86.0°F)

C.O./CCO Alarm Specifications	Range	Adjustment	Delay
TBlood	17 to 43°C	Steps of 0.5°C (17 to 35°C) Steps of 0.1°C (35 to 43°C) Steps of 1°F (63 to 95°F) Steps of 0.2°F (95 to 109°F)	10 seconds after the value exceeds the set limit range
CCO	0.1 to 25.0 l/min	0.1 l/min (0.1 to 10.0 l/min) 0.5 l/min (10.0 to 25.0 l/min)	10 seconds after the value exceeds the set limit range

tcGas

Complies with IEC 60601-2-23:1999/EN 60601-2-23:2000.

tcGas Performance Specifications		
tcpO2	Range	0 to 750 mmHg (0 to 100 kPa)
	Resolution	1 mmHg (0.1 kPa)
	Overall Accuracy (incl. transducer)	0 to 20.9% O ₂ better than +5 mmHg (+0.7 kPa) Above 20.9% O ₂ better than +10% of reading
tcpO2 Test Signal		60 mmHg (8.0 kPa)
tcpO2 Drift, including transducer		Typically 1.25%/h
tcpO2 response time, including transducer		Typically 30 s
tcpCO2	Range	5 to 200 mmHg (0.7 to 26.7 kPa)
	Resolution	1 mmHg (0.1 kPa)
	Overall Accuracy (incl. transducer)	5 to 76 mmHg (0.7 to 10.1 kPa) better than +5 mmHg (+0.7 kPa) Above 76 mmHg (10.1 kPa) better than +10% of reading
tcpCO2 Test Signal		40 mmHg (5.3 kPa)
tcpCO2 Drift, including transducer		Typically 2.5%/h
tcpCO2 response time, including transducer		Typically 60 s
Warm-up Time		<3 minutes
Site Timer (M1018A only)		0.5, 1, 1.5, 2, 2.5, 3, 4, 5, 6, 7, or 8 hours. Change Site alarm when site time is expired and configurable automatic heating switch-off
Transducer Heating		Available Temperatures - 37.0°C, 41.0 to 45°C in steps of 0.5°C

tcGas Alarm Specifications	Range	Adjustment	Alarm Delay
tcpO2	10 to 745 mmHg 1.0 to 99.5 kPa	10 to 30 mmHg: 1 mmHg 1.0 to 4.0 kPa: 0.1 kPa 32 to 100 mmHg: 2 mmHg 4.2 to 13 kPa: 0.2 kPa 105 to 745 mmHg: 5 mmHg 13.5 to 99.5 kPa: 0.5 kPa	10 seconds after the value exceeds the set limit range.
tcpCO2	10 to 195 mmHg 1.0 to 26 kPa	10 to 30 mmHg: 1 mmHg 1.0 to 4.0 kPa: 0.1 kPa 32 to 100 mmHg: 2 mmHg 4.2 to 13 kPa: 0.2 kPa 105 to 195 mmHg: 5 mmHg 13.5 to 26 kPa: 0.5 kPa	

Intravascular Oxygen Saturation

Complies with IEC 60601-2-49:2001.

Performance Specifications		
SO2, SvO2, ScvO2	Range	10% to 100%
	Accuracy	±2% (i.e. ±2 units), 1 standard deviation over 40% to 100% ¹ range.
	Resolution	1%
Stability (system)		Drift <2% over 24 hours
Response Time (10 % to 90 %)		5 seconds

¹ The accuracy specification for Edwards Lifesciences' Philips-compatible catheters has been verified in the saturation range 40%-95%.

Alarm Specifications	Range	Adjustment	Delay
SO2, SvO2, ScvO2	10% to 100%	1%	max. 15 +4 seconds after value exceeds the set limit range

EEG

Complies with IEC 60601-2-26:1994/EN 60601-2-26:1994.

EEG Performance Specifications		
Leakage Current	<=10 mA @ 110 Vac	
Input Signal Range	1 mVp-p	
Differential Input Impedance	>15 MΩ @ 10 Hz	
Max. DC Input Offset Voltage	±320 mV	
Input Protection	Against defibrillation (5 kV) and electrosurgery	
Common Mode Rejection	>105 dB @ 5 kΩ imbalance and 60 Hz	
Noise	<0.4 μVrms (1 to 30 Hz)	
Electromagnetic Susceptibility	<10 μVp-p @ 3 V/m, 26-1000 MHz	
Electrode Impedance Measurement	Range	0 to 30 kΩ
	Accuracy	±1 kΩ

40 Specifications

EEG Performance Specifications	
Bandwidth	0.5 Hz to 50 Hz (-3 dB)
Low Filter Cut-Off Frequencies	0.5, 1.0, 2.0, and 5.0 Hz (12 dB/octave)
High Filter Cut-Off Frequencies	15 Hz (65 dB/octave) 30 Hz (75 dB/octave) 50 Hz (85 dB/octave)

BIS

Complies with IEC 60601-2-26:1994.

BIS Performance Specifications	BIS, BISx M1034A
Bispectral Index (BIS) Range	0 - 100
Signal Quality Index (SQI) Range	0 - 100%
EMG Range	0 - 100 dB
Suppression Ratio (SR)	0 - 100%
Spectral Edge Frequency (SEF)	0.5 - 30.0 Hz
Total Power (TP)	0 - 100 dB
Bursts	(BISx only) 0 - 30 /minute
Noise	<0.3 μ V RMS (2.0 μ V peak-to-peak)
Wave Scale	<i>With gridlines on:</i> ± 25 μ V, ± 50 μ V, ± 100 μ V, ± 250 μ V <i>With gridlines off:</i> 50 μ V, 100 μ V, 200 μ V, 500 μ V
Update Frequency (BIS Numeric)	2048 ms
Bandwidth	0.25 - 100 Hz (-3 dB)
High Pass Filters	0.25 Hz, 1 Hz, 2 Hz (-3 dB)
Low Pass Filters	30 Hz, 50 Hz, 70 Hz, 100 Hz (-3 dB)
Notch Filters (for line frequency)	50 Hz, 60 Hz
Impedance Measurement Range	0 to 999 k Ω

BIS Alarm Specifications	Range	Adjustment	Alarm Delay
BIS High/Low Alarm	0 - 100	1	Max. 2 seconds

NMT

Complies with IEC 60601-2-49:2001

NMT Performance Specifications		
Stimulation Output	Current Pulse	100, 200, or 300 μ secs; monophasic rectangle pulse
	Current Range	5 to 60 mA in increments of 5 mA
	Current Accuracy	$\pm 5\%$ or ± 2 mA, whichever is greater
	Maximum Skin Resistance	3 kOhm
	Maximum Output Voltage	300 V $\pm 10\%$
Single Twitch Stimulation Mode	Twitch	0 to 200% (resolution: 1%)
	Repeat Time	Manual, or 1 sec, 12 sec, 30 sec
	Minimum Recovery Time	None

NMT Performance Specifications		
Train-Of-Four Stimulation Mode	TOF Count (TOFcnt)	0 to 4 (resolution: 1)
	TOF Ratio (TOFrat)	5 to 150% (resolution: 1)
	Repeat Time	Manual, or 12 sec, 30 sec, 1 min, 5 min, 10 min, 15 min, 30 min, 60 min
	Minimum Recovery Time	10 sec
Post-Tetanic-Count Stimulation Mode	PTC	0 to 20 (resolution: 1)
	Repeat Time	Manual
	Minimum Recovery Time	2 min
Double-Burst Stimulation Mode	Repeat Time	Manual
	Minimum Recovery Time	20 sec

NMT Alarm Specifications	Range	Alarm Delay
** TOFcnt High	0, 1, 2, 3 TOF Counts	Max. 4 sec system delay after value goes above the high alarm limit setting

Safety and Performance Tests

You must observe any national regulations on the qualification of the testing personnel and suitable measuring and testing facilities. See the maintenance section for a list of required tests. Safety and performance tests, and what to do if the instrument does not meet these specifications, are described in the Service Guide.

Electromagnetic Compatibility (EMC) Specifications

Take special precautions regarding electromagnetic compatibility (EMC) when using medical electrical equipment. You must operate your monitoring equipment according to the EMC information provided in this book. Portable and mobile radiofrequency (RF) communications equipment can affect medical electrical equipment.

Accessories Compliant with EMC Standards

All accessories listed in the accessories section comply, in combination with the patient monitor, with the requirements of IEC 60601-1-2:2001 + A1:2004.

WARNING

Using accessories other than those specified may result in increased electromagnetic emission or decreased electromagnetic immunity of the monitoring equipment.

Electromagnetic Emissions

The monitor is suitable for use in the electromagnetic environment specified in the table below. You must ensure that it is used in such an environment.

Emissions test	Compliance	Avoiding Electromagnetic Interference
Radiofrequency (RF) emissions	Group 1	The monitor uses RF energy only for its internal function. Therefore, its RF emissions are very low and are not likely to cause any interference in nearby electronic equipment
RF emissions CISPR 11	Class A	The monitor is suitable for use in all establishments other than domestic and those directly connected to the public low-voltage power supply network that supplies buildings used for domestic purposes
Harmonic emissions IEC 61000-3-2	n/a	
Voltage fluctuations IEC 61000-3-3	n/a	

WARNING

The monitor should not be used next to or stacked with other equipment. If you must stack the monitor, you must check that normal operation is possible in the necessary configuration before you start monitoring patients.

Avoiding Electromagnetic Interference (Resp and BIS)

The respiration (Resp) and BIS measurements are very sensitive measurements that measure very small signals. Technological limitations do not allow higher immunity levels than 1 V/m for radiated RF electromagnetic fields and 1 Vrms for conducted disturbances induced by RF fields. Electromagnetic fields with field strengths above 1 V/m and conducted disturbances above 1 Vrms may cause erroneous measurements. Therefore Philips recommends that you avoid using electrically radiating equipment in the close proximity of these measurements.

Electromagnetic Immunity

The monitor is suitable for use in the specified electromagnetic environment. The user must ensure that it is used in the appropriate environment as described below.

Immunity test	IEC 60601-1-2 test level	Compliance level	Electromagnetic environment guidance
Electrostatic discharge (ESD) IEC 61000-4-2	±6 kV contact ±8 kV air	±6 kV contact ±8 kV air	Floors should be wood, concrete, or ceramic tile. If floors are covered with synthetic material, the relative humidity should be at least 30%.
Electrical fast transient/burst IEC 61000-4-4	±2 kV for power supply lines ±1 kV for input/output lines	±2 kV for power supply lines ±1 kV for input/output lines	Mains power quality should be that of a typical commercial and/or hospital environment
Surge IEC 61000-4-5	±1 kV differential mode ±2 kV common mode	±1 kV differential mode ±2 kV common mode	Mains power quality should be that of a typical commercial and/or hospital environment
Voltage dips, short interruptions and voltage variations on power supply input lines IEC 61000-4-11	<5% U_T (>95% dip in U_T) for 0.5 cycles	<5% U_T (>95% dip in U_T) for 0.5 cycles	Mains power quality should be that of a typical commercial and/or hospital environment. If the user of the monitor requires continued operation during power mains interruptions, it is recommended that the monitor is equipped with an internal battery or is powered from an uninterruptible power supply.
	40% U_T (60% dip in U_T) for 5 cycles	40% U_T (60% dip in U_T) for 5 cycles	
	70% U_T (30% dip in U_T) for 25 cycles	70% U_T (30% dip in U_T) for 25 cycles	
	<5% U_T (>95% dip in U_T) for 5 sec	<5% U_T (>95% dip in U_T) for 5 sec	

Immunity test	IEC 60601-1-2 test level	Compliance level	Electromagnetic environment guidance
Power frequency (50/60 Hz) magnetic field IEC 61000-4-8	3 A/m	3 A/m	Power frequency magnetic fields should be at levels characteristic of a typical location in a typical commercial and/or hospital environment

In this table, U_T is the a.c. mains voltage prior to application of the test level.

Recommended Separation Distance

WARNING

- This equipment generates, uses and radiates radio-frequency energy, and if it is not installed and used in accordance with its accompanying documentation, may cause interference to radio communications.
- The monitor, equipped with a wireless network interface, intentionally receives RF electromagnetic energy for the purpose of its operation. Therefore, other equipment may cause interference, even if that other equipment complies with CISPR emission requirements.

In the following table, P is the maximum output power rating of the transmitter in watts (W) according to the transmitter manufacturer and d is the recommended separation distance in meters (m). The values given in brackets are for respiration and BIS.

Portable and mobile RF communications equipment should be used no closer to any part of the monitor, including cables, than the recommended separation distance calculated from the equation appropriate for the frequency of the transmitter.

Field strengths from fixed RF transmitters, as determined by an electromagnetic site survey, should be less than the compliance level in each frequency range.

Interference may occur in the vicinity of equipment marked with this symbol:



Immunity test	IEC 60601-1-2 test level	Compliance level	Electromagnetic environment guidance
Conducted RF IEC 61000-4-6	3 Vrms 150 kHz to 80 MHz	3 Vrms (1 Vrms for respiration and BIS)	Recommended separation distance: $d = 1.2\sqrt{P}$ for respiration and BIS: $d = 3.5\sqrt{P}$

Immunity test	IEC 60601-1-2 test level	Compliance level	Electromagnetic environment guidance
Radiated RF IEC 61000-4-3	3 V/m 80 MHz to 2.5 GHz	3 V/m (1 V/m for respiration and BIS)	Recommended separation distance: 80 MHz to 800 MHz $d = 1.2\sqrt{P}$ 80 MHz to 800 MHz for respiration and BIS $d = 3.5\sqrt{P}$ 800 MHz to 2,5 GHz $d = 2.3\sqrt{P}$ 800 MHz to 2,5 GHz for respiration and BIS $d = 7.0\sqrt{P}$ 2.0 to 2,3 GHz for short range radio $d = 7.0\sqrt{P}$

Field strengths from fixed transmitters, such as base stations for radio (cellular, cordless) telephones and land mobile radios, amateur radio, AM and FM radio broadcast and TV broadcast cannot be predicted theoretically with accuracy. To assess the electromagnetic environment due to fixed RF transmitters, an electromagnetic site survey should be considered. If the measured field strength in the location in which the monitor is used exceeds the applicable RF compliance level above, the monitor should be observed to verify normal operation. If abnormal performance is observed, additional measures may be necessary, such as reorienting or relocating the monitor.

These guidelines may not apply in all situations. Electromagnetic propagation is affected by absorption and reflection from structures, objects, and people.

Recommended Separation Distances from Portable and Mobile RF Communication Equipment

The monitor is intended for use in an electromagnetic environment in which radiated RF disturbances are controlled. The customer or user of the monitor can help prevent electromagnetic interference by maintaining a minimum distance between portable and mobile RF communications equipment and the monitor as recommended below, according to the maximum output power of the communications equipment.

In the following table, P is the maximum output power rating of the transmitter in watts (W) according to the transmitter manufacturer and d is the recommended separation distance in meters (m). The values given in brackets are for respiration and BIS.

Frequency of transmitter	150 kHz to 80 MHz	80 MHz to 800 MHz	800 MHz to 2,5 GHz
Equation	$d = 1.2\sqrt{P}$ for respiration and BIS: $d = 3.5\sqrt{P}$	$d = 1.2\sqrt{P}$ for respiration and BIS: $d = 3.5\sqrt{P}$	$d = 2.3\sqrt{P}$ for respiration and BIS: $d = 7.0\sqrt{P}$
Rated max. output power of transmitter	Separation distance	Separation distance	Separation distance
0.01 W	0.1 (0.4) m	0.1 (0.4) m	0.2 (0.7) m
0.1 W	0.4 (1.1) m	0.4 (1.1) m	0.7 (2.2) m
1 W	1.3 (3.5) m	1.3 (3.5) m	2.3 (7.0) m
10 W	3.8 (11.1) m	3.8 (11.1) m	7.3 (22.1) m
100 W	12.0 (35.0) m	12.0 (35.0) m	23.0 (70.0) m

Recommended Separation Distances for WLAN Operation

To avoid interference in the presence of other RF sources, following separation distances are recommended;

- A separation distance of 1 m to BlueTooth (Class 1), DECT and WLAN devices (if connected to a different WLAN infrastructure) operating in the same frequency band.
- A separation distance of 3 m to other radio transmitters with a pulsed mode of operation and a duty cycle less than 50%, operating in the same frequency band.
- A separation distance of 10 m to a consumer grade microwave oven and 30 m to a commercial grade microwave oven, if operating in the 2,4 GHz band.

If other continuous wave transmitters operate in the same frequency band, a minimum signal-to-noise ratio (SNR) of 25 dB should be provided at the monitor location.

These guidelines may not apply in all situations. Electromagnetic propagation is affected by absorption and reflection from structures, objects, and people.

Electrosurgery Interference/Defibrillation/Electrostatic Discharge

The equipment returns to the previous operating mode within 10 seconds without loss of any stored data. Measurement accuracy may be temporarily decreased while performing electrosurgery or defibrillation. This does not affect patient or equipment safety. Do not expose the equipment to x-ray or strong magnetic fields (MRI).

Fast Transients/Bursts

The equipment will return to the previous operating mode within 10 seconds without loss of any stored data (M1032A within 30 seconds). If any user interaction is required, the monitor indicates this with a technical alarm (INOP).

Restart time

After a power interruption, an ECG wave will be shown on the display after 30 seconds maximum. If an X2 is connected to a host monitor, it can take up to a maximum of 45 seconds until the ECG wave is shown.

Default Settings Appendix

This appendix documents the most important default settings of your monitor as it is delivered from the factory. For a comprehensive list and explanation of default settings, see the Configuration Guide supplied with your monitor. The monitor's default settings can be permanently changed in Configuration Mode.

Note: If your monitor has been ordered pre-configured to your requirements, the settings at delivery will be different from those listed here.

Country-Specific Default Settings

Certain default settings are specific to a particular country. These are listed here for all countries alphabetically.

Country-Description	Line Frequency 50/60 [Hz]	Units Weight kg, lb	Units Height in, cm	ECG Cable Color IEC, AAMI
Afghanistan	50	kg	cm	AAMI
Åland Islands	50	kg	cm	IEC
Albania	50	kg	cm	IEC
Algeria	50	kg	cm	IEC
American Samoa	60	lb	in	AAMI
Andorra	60	lb	in	AAMI
Angola	50	kg	cm	IEC
Anguilla	60	lb	in	AAMI
Antarctica	60	lb	in	AAMI
Antigua and Barbuda	50	kg	cm	AAMI
Argentina	50	kg	cm	AAMI
Armenia	50	kg	cm	IEC
Aruba	60	kg	cm	AAMI
Australia	50	kg	cm	AAMI
Austria	50	kg	cm	IEC
Azerbaijan	50	kg	cm	IEC

41 Default Settings Appendix

Country-Description	Line Frequency 50/60 [Hz]	Units Weight kg, lb	Units Height in, cm	ECG Cable Color IEC, AAMI
Bahamas	60	kg	cm	AAMI
Bahrain	50	kg	cm	AAMI
Bangladesh	50	kg	cm	IEC
Barbados	50	kg	cm	AAMI
Belarus	50	kg	cm	IEC
Belgium	50	kg	cm	IEC
Belize	60	lb	in	AAMI
Benin	60	lb	in	AAMI
Bermuda	60	kg	cm	AAMI
Bhutan	60	lb	in	AAMI
Bolivia	60	kg	cm	AAMI
Bosnia and Herzegovina	50	kg	cm	IEC
Botswana	50	kg	cm	IEC
Bouvet Island	60	lb	in	AAMI
Brazil	60	kg	cm	AAMI
British Indian Ocean Territory	60	lb	in	AAMI
Brunei Darussalam	50	kg	cm	IEC
Bulgaria	50	kg	cm	IEC
Burkina Faso	50	kg	cm	IEC
Burundi	50	kg	cm	IEC
Cambodia	50	kg	cm	IEC
Cameroon	50	kg	cm	IEC
Canada	60	kg	cm	AAMI
Cape Verde	60	lb	in	AAMI
Cayman Islands	60	kg	cm	AAMI
Central African Republic	50	kg	cm	IEC
Chad	60	lb	in	AAMI
Chile	50	kg	cm	AAMI
China	50	kg	cm	AAMI
Christmas Islands	60	lb	in	AAMI
Cocos Keeling Islands	60	lb	in	AAMI
Colombia	60	kg	cm	AAMI
Comoros	60	lb	in	AAMI
Congo	50	kg	cm	IEC
Congo, The Democratic Republic of the	50	kg	cm	IEC

Country-Description	Line Frequency 50/60 [Hz]	Units Weight kg, lb	Units Height in, cm	ECG Cable Color IEC, AAMI
Cook Islands	60	lb	in	AAMI
Costa Rica	60	kg	cm	AAMI
Côte d'Ivoire	50	kg	cm	IEC
Croatia	50	kg	cm	IEC
Cuba	60	kg	cm	IEC
Cyprus	50	kg	cm	IEC
Czech Republic	50	kg	cm	IEC
Denmark	50	kg	cm	IEC
Djibouti	50	kg	cm	IEC
Dominica	50	kg	cm	AAMI
Dominican Republic	60	kg	cm	AAMI
Ecuador	60	kg	cm	AAMI
Egypt	50	kg	cm	IEC
El Salvador	60	kg	cm	AAMI
Equatorial Guinea	50	kg	cm	IEC
Eritrea	50	kg	cm	IEC
Estonia	50	kg	cm	IEC
Ethiopia	50	kg	cm	IEC
Falkland Islands, Malvinas	60	lb	in	AAMI
Faroe Islands	60	lb	in	AAMI
Fiji	60	lb	in	AAMI
Finland	50	kg	cm	IEC
France	50	kg	cm	IEC
French Guiana	50	kg	cm	IEC
French Polynesia	60	lb	in	AAMI
French Southern Territories	60	lb	in	AAMI
Gabon	50	kg	cm	IEC
Gambia	50	kg	cm	IEC
Georgia	60	lb	in	AAMI
Germany	50	kg	cm	IEC
Ghana	50	kg	cm	IEC
Gibraltar	60	lb	in	AAMI
Greece	50	kg	cm	IEC
Greenland	60	lb	in	AAMI
Grenada	50	kg	cm	AAMI
Guadeloupe	50	kg	cm	IEC

41 Default Settings Appendix

Country-Description	Line Frequency 50/60 [Hz]	Units Weight kg, lb	Units Height in, cm	ECG Cable Color IEC, AAMI
Guam	60	lb	in	AAMI
Guatemala	60	kg	cm	AAMI
Guernsey	50	kg	cm	IEC
Guinea	60	lb	in	AAMI
Guinea-Bissau	60	lb	in	AAMI
Guyana	60	kg	cm	AAMI
Haiti	60	kg	cm	AAMI
Heard Island and McDonald Islands	60	lb	in	AAMI
Holy See, Vatican City State	60	lb	in	AAMI
Honduras	60	kg	cm	AAMI
Hong Kong	50	kg	cm	IEC
Hungary	50	kg	cm	IEC
Iceland	50	kg	cm	IEC
India	50	kg	cm	IEC
Indonesia	50	kg	cm	IEC
Iran, Islamic Republic of	50	kg	cm	AAMI
Iraq	50	kg	cm	AAMI
Ireland	50	kg	cm	IEC
Isle of Man	50	kg	cm	IEC
Israel	50	kg	cm	IEC
Italy	50	kg	cm	IEC
Jamaica	50	kg	cm	AAMI
Japan	50	kg	cm	IEC
Jersey	50	kg	cm	IEC
Jordan	50	kg	cm	AAMI
Kazakhstan	50	kg	cm	IEC
Kenya	50	kg	cm	IEC
Kiribati	60	lb	in	AAMI
Korea, Democratic People's Republic of	60	lb	in	AAMI
Korea, Republic of	60	kg	cm	AAMI
Kuwait	50	kg	cm	AAMI
Kyrgyzstan	60	lb	in	AAMI
Lao People's Democratic Republic	50	kg	cm	IEC
Latvia	50	kg	cm	IEC

Country-Description	Line Frequency 50/60 [Hz]	Units Weight kg, lb	Units Height in, cm	ECG Cable Color IEC, AAMI
Lebanon	50	kg	cm	AAMI
Lesotho	50	kg	cm	IEC
Liberia	50	kg	cm	IEC
Libyan Arab Jamahiriya	60	lb	in	AAMI
Liechtenstein	60	lb	in	AAMI
Lithuania	50	kg	cm	IEC
Luxembourg	50	kg	cm	IEC
Macao	50	kg	cm	IEC
Macedonia, The former Yugoslavian Republic of	50	kg	cm	IEC
Madagascar	50	kg	cm	IEC
Malawi	50	kg	cm	IEC
Malaysia	50	kg	cm	IEC
Maldives	60	lb	in	AAMI
Mali	50	kg	cm	IEC
Malta	50	kg	cm	IEC
Marshall Islands	60	lb	in	AAMI
Martinique	60	kg	cm	IEC
Mauritania	50	kg	cm	IEC
Mauritius	60	lb	in	AAMI
Mayotte	60	lb	in	AAMI
Mexico	60	kg	cm	AAMI
Micronesia, Federal States of	60	lb	in	AAMI
Moldova, Republic of	60	lb	in	AAMI
Monaco	60	lb	in	AAMI
Mongolia	60	lb	in	AAMI
Montenegro	50	kg	cm	IEC
Montserrat	50	kg	cm	AAMI
Morocco	50	kg	cm	IEC
Mozambique	50	kg	cm	IEC
Myanmar	60	lb	in	AAMI
Namibia	50	kg	cm	IEC
Nauru	60	lb	in	AAMI
Nepal	50	kg	cm	IEC
Netherlands	50	kg	cm	IEC
Netherlands Antilles	50	kg	cm	AAMI

41 Default Settings Appendix

Country-Description	Line Frequency 50/60 [Hz]	Units Weight kg, lb	Units Height in, cm	ECG Cable Color IEC, AAMI
New Caledonia	60	lb	in	AAMI
New Zealand	50	kg	cm	AAMI
Nicaragua	60	kg	in	AAMI
Niger	50	kg	cm	IEC
Nigeria	50	kg	cm	IEC
Niue	60	lb	in	AAMI
Norfolk Islands	60	lb	in	AAMI
Northern Mariana Islands	60	lb	in	AAMI
Norway	50	kg	cm	IEC
Oman	50	kg	cm	AAMI
Pakistan	50	kg	cm	IEC
Palau	60	lb	in	AAMI
Palestinian Territory	50	kg	cm	AAMI
Panama	60	lb	in	AAMI
Papua New Guinea	60	lb	in	AAMI
Paraguay	50	kg	cm	AAMI
Peru	60	kg	cm	AAMI
Philippines	60	kg	cm	AAMI
Pitcairn	60	lb	in	AAMI
Poland	50	kg	cm	IEC
Portugal	50	kg	cm	IEC
Puerto Rico	60	lb	in	AAMI
Qatar	50	kg	cm	AAMI
Reunion	60	lb	in	AAMI
Romania	50	kg	cm	IEC
Russian Federation	50	kg	cm	IEC
Rwanda	50	kg	cm	IEC
Saint Helena	60	lb	in	AAMI
Saint Kitts and Nevis	60	kg	cm	AAMI
Saint Lucia	50	kg	cm	AAMI
Saint Pierre and Miquelon	60	lb	in	AAMI
Saint Vincent & the Grenadines	50	kg	cm	AAMI
Samoa	60	lb	in	AAMI
San Marino	60	lb	in	AAMI
Sao Tome and Principe	60	lb	in	AAMI
Saudi Arabia	50	kg	cm	AAMI

Country-Description	Line Frequency 50/60 [Hz]	Units Weight kg, lb	Units Height in, cm	ECG Cable Color IEC, AAMI
Senegal	50	kg	cm	IEC
Serbia	50	kg	cm	IEC
Serbia & Montenegro	50	kg	cm	IEC
Seychelles	60	lb	in	AAMI
Sierra Leone	50	kg	cm	IEC
Singapore	50	kg	cm	IEC
Slovakia	50	kg	cm	IEC
Slovenia	50	kg	cm	IEC
Solomon Islands	60	lb	in	AAMI
Somalia	50	kg	cm	IEC
South Africa	60	lb	in	AAMI
South Georgia and the South Sandwich Islands	60	lb	in	AAMI
Spain	50	kg	cm	IEC
Sri Lanka	50	kg	cm	IEC
Sudan	50	kg	cm	IEC
Suriname	60	kg	cm	AAMI
Svalbard and Jan Mayen	60	lb	in	AAMI
Swaziland	60	lb	in	AAMI
Sweden	50	kg	cm	IEC
Switzerland	50	kg	cm	IEC
Syrian Arab Rep	50	kg	cm	AAMI
Taiwan, Province of China	60	kg	cm	AAMI
Tajikistan	60	lb	in	AAMI
Tanzania, United Republic of	60	lb	in	AAMI
Thailand	50	kg	cm	AAMI
Timor-Leste	60	lb	in	AAMI
Togo	60	lb	in	AAMI
Tokelau	60	lb	in	AAMI
Tonga	60	lb	in	AAMI
Trinidad and Tobago	60	kg	cm	AAMI
Tunisia	50	kg	cm	IEC
Turkey	50	kg	cm	IEC
Turkmenistan	60	lb	in	AAMI
Turks and Caicos Islands	60	kg	cm	AAMI
Tuvalu	60	lb	in	AAMI

Country-Description	Line Frequency 50/60 [Hz]	Units Weight kg, lb	Units Height in, cm	ECG Cable Color IEC, AAMI
Uganda	60	lb	in	AAMI
Ukraine	60	lb	in	AAMI
United Arab Emirates	50	kg	cm	AAMI
United Kingdom	50	kg	cm	IEC
United States	60	lb	in	AAMI
United States Minor Outlying Islands	60	lb	in	AAMI
Uruguay	50	kg	cm	AAMI
Uzbekistan	60	lb	in	AAMI
Vanuatu	60	lb	in	AAMI
Venezuela	60	lb	in	AAMI
Viet Nam	50	kg	cm	IEC
Virgin Islands, British	50	kg	cm	AAMI
Virgin Islands, United States	60	lb	in	AAMI
Wallis and Futuna Islands	60	lb	in	AAMI
Western Sahara	50	kg	cm	IEC
Yemen	50	kg	cm	AAMI
Zambia	60	lb	in	AAMI
Zimbabwe	60	lb	in	AAMI

Alarm and Measurement Default Settings

The default wave speed for all measurements except Respiration is 25 mm/sec. For Respiration the default wave speed is 6.25 mm/sec.

In the following tables, settings may be entered only once per table row if they are the same for all patient categories.

Alarm Default Settings

Alarm Settings	Factory Default H10/H20/H40	H30 (deviations from H10/H20/ H40)
Alarm Volume	5	
Alarms Off	2 min	
Pause Al. 5min	Enabled	
Pause Al. 10min	Enabled	
Auto Alarms Off	Off	
AlarmOffReminder	Off	
Visual Latching	Red&Yellow	Red Only

Alarm Settings	Factory Default H10/H20/H40	H30 (deviations from H10/H20/H40)
Audible Latching	Red&Yellow	Off
Alarm Reminder	On	
Reminder Time	3 min	
Alarm Sounds	Traditional	
RedAlarmInterval	10 sec	
Yel.Al. Interval	20 sec	
Alarm Low	4	2
Red Alarm Volume	AlarmVol. +2	
Yell.AlarmVolume	AlarmVol. +0	
INOP Volume	AlarmVol. +0	
AutoIncrease Vol	2 Steps	
IncreaseVolDelay	20 sec	
Keep Blinking	No	
Relay1 Sensitiv.	R&Y&C	
Relay2 Sensitiv.	Red&Yellow	
Relay3 Sensitiv.	Red	
CyanRelayLatency	5 sec	
Yel.RelayLatency	2 sec	
Alarm Text	Standard	
NoCentrMonMinVol	On4	

ECG, Arrhythmia, ST and QT Default Settings

ECG Settings	Factory defaults H10/H20/H40			H30 (deviations from H10/H20/H40)		
	Adult	Pedi	Neo	Adult	Pedi	Neo
High Limit	120 bpm	160 bpm	200 bpm			
Low Limit	50 bpm	75 bpm	100 bpm			
ECG/Arrhy Alarms	On	On	On			
Alarm Source	Auto	Auto	Auto	Auto		
ECG	On	On	On			
QRS Volume	1	1	1			
Primary Lead	II	II	II			
Secondary Lead	V	V	V			
Analysis Mode	Multi Lead	Multi Lead	Multi Lead			
Lead Placement	Standard	Standard	Standard			
Mod.LeadPlacment	Off	Off	Off			
Filter	Monitor	Monitor	Monitor	Filter		
AutoFilter	Off	Off	Off			
Default ECG Size	Size x1	Size x1	Size x1			
Color	Green	Green	Green			

ECG Settings	Factory defaults H10/H20/H40			H30 (deviations from H10/H20/H40)		
	Adult	Pedi	Neo	Adult	Pedi	Neo
Asystole Thresh.	4.0 sec	4.0 sec	3.0 sec			
Δ ExtrTachy	20 bpm	20 bpm	20 bpm			
Tachy Clamp	200 bpm	220 bpm	240 bpm			
Δ ExtrBrady	20 bpm	20 bpm	20 bpm			
Brady Clamp	40 bpm	40 bpm	50 bpm	40 bpm	60 bpm	80 bpm
ECG Alm Off INOP	Cyan	Cyan	Cyan			
Fallback	On	On	On			
Alarms Off	Enabled	Enabled	Enabled			
AlarmSource Sel.	Enabled	Enabled	Enabled			
Va Lead	V2	V2	V2			
Vb Lead	V5	V5	V5			
SyncPulse Sensit	Medium	Medium	Medium			
SyncPulse Marker	On	On	On			
PulseAlarms Tele	Enabled	Enabled	Enabled			

Arrhythmia Default Settings

Arrhythmia Settings	Factory defaults H10/H20/H40			H30 (deviations from H10/H20/H40)		
	Adult	Pedi	Neo	Adult	Pedi	Neo
Arrhythmia	On	On	Off	Off	Off	Off
Pause Threshold	2.0 sec	2.0 sec	1.5 sec			
VTach HR	100	120	150			
VTach Run	5	5	5			
Vent Rhythm	14	14	14			
SVT HR	180	200	210			
SVT Run	5	5	5			
PVCs/min	10	5	5			
Non-Sustain	On	On	On			
Vent Rhythm	On	On	On			
Run PVCs	On	On	On			
Pair PVCs	On	On	On	Off	Off	Off
R-on-T PVCs	On	On	On	Off	Off	Off
V.Bigeminy	On	On	On	Off	Off	Off
V.Trigeminy	On	On	On	Off	Off	Off
PVCs/min	On	On	On	Off	Off	Off
Multif.PVCs	On	On	On	Off	Off	Off
Pacer n.Cap	On	On	On			
Pacer n.Pac	On	On	On			
Pause	On	On	On	Off	Off	Off
Missed Beat	On	On	On	Off	Off	Off

Arrhythmia Settings	Factory defaults H10/H20/H40			H30 (deviations from H10/H20/H40)		
	Adult	Pedi	Neo	Adult	Pedi	Neo
SVT	On	On	On			
Afib	On	On	On			
Irregular HR	On	On	On	Off	Off	Off
HR Alarms	Short Yellow	Short Yellow	Short Yellow			
TimeOut 1st	3 min	3 min	3 min			
TimeOut 2nd	10 min	10 min	10 min			
ArrhyOff Message	Yes	Yes	Yes			
Some ECG AI INOP	On	On	On	Off	Off	Off

ST and QT Default Settings

Lead-independent ST Settings	Factory Defaults		
	Factory Adult	Factory Pedi	Factory Neo
ISO/J Point detection	Auto	Auto	Auto
Alarms (ST)	On	On	On
STE	Off	Off	Off
Alarms (STE)	On	On	On
ST Analysis	On	Off	Off
ST-Index	Off	Off	Off
ISO Point	-80 ms	-80 ms	-80 ms
J Point	48 ms	48 ms	48 ms
ST Offset	J+60	J+60	J+60

ST Settings - Lead I, II, III, V, aVR, aVL, V1-6, MCL	Factory Defaults		
	Factory Adult	Factory Pedi	Factory Neo
ST (Label) High Alarm Limit	+1.0 mm	+1.0 mm	+1.0 mm
ST (Label) Low Alarm Limit	-1.0 mm	-1.0 mm	-1.0 mm
ST Settings - Lead V, MCL			
ST (Label) High Alarm Limit	+2.0 mm	+2.0 mm	+2.0 mm
ST (Label) Low Alarm Limit	-2.0 mm	-2.0 mm	-2.0 mm
STE Settings - Limb leads			
STE Male Limb, Alarm Limit	1.0 mm	1.0 mm	1.0 mm
STE Female Limb, Alarm Limit	1.0 mm	1.0 mm	1.0 mm
ST Settings - lead V2, V3			
STE Male V2,V3, Alarm Limit			
STE Female V2,V3, Alarm Limit			
STE Settings - V1, V4-V6			
STE Male V1,V4-6, Alarm Limit	1.0 mm	1.0 mm	1.0 mm

ST Settings - Lead I, II, III, V, aVR, aVL, V1-6, MCL	Factory Defaults		
	Factory Adult	Factory Pedi	Factory Neo
STE Fem. V1,V4-6, Alarm Limit	1.0 mm	1.0 mm	1.0 mm

QT Settings	Factory Defaults		
	Factory Adult	Factory Pedi	Factory Neo
QT Lead	All	All	All
QTc High Limit	500 ms	480 ms	460 ms
ΔQTc High Limit	60 ms	60 ms	60 ms
QTc High Alarm	On	On	On
ΔQTc High Alarm	On	On	On
QT Analysis	Off	Off	Off
QTc Formula	Bazett	Bazett	Bazett

Pulse Default Settings

Pulse Settings	Factory defaults H10/H20/H40			H30 (deviations from H10/H20/H40)		
	Adult	Pedi	Neo	Adult	Pedi	Neo
Alarm Source	Auto	Auto	Auto	Auto	Auto	Auto
Pulse (source label)	On	On	On			
System Pulse	SpO ₂	SpO ₂	SpO ₂	Auto	Auto	Auto
Alarms Off	Enabled	Enabled	Enabled			
AlarmSource Sel.	Enabled	Enabled	Enabled			

Pulse Alarm Settings	Factory defaults H10/H20/H40			H30 (deviations from H10/H20/H40)		
	Adult	Pedi	Neo	Adult	Pedi	Neo
Pulse Alarms ¹	On	On	On			
High Limit	120 bpm	160 bpm	200 bpm			
Low Limit	50 bpm	75 bpm	100 bpm			
Δ ExtrBrady	20 bpm	20 bpm	20 bpm			
Brady Clamp	40 bpm	40 bpm	50 bpm	40 bpm	60 bpm	80 bpm
Δ ExtrTachy	20 bpm	20 bpm	20 bpm			
Tachy Clamp	200 bpm	220 bpm	240 bpm			

¹ When Pulse is not the alarm source, the alarms will be **Off**.

Pulse alarms use the settings of the currently selected Pulse alarm source.

Respiration Default Settings

Respiration Settings	Factory defaults H10/H20/H40			H30 (deviations from H10/H20/H40)		
	Adult	Pedi	Neo	Adult	Pedi	Neo
High Limit	30 rpm	30 rpm	100 rpm			
Low Limit	8 rpm	8 rpm	30 rpm			
Apnea Time	20 sec	20 sec	20 sec			
Alarms	On	On	On			
Resp	On	On	On	Off	Off	Off
Detection	Auto (Trigger Mode)	Auto (Trigger Mode)	Auto (Trigger Mode)			
Color	Yellow	Yellow	Yellow	White	White	White

SpO₂ Default Settings

SpO ₂ Settings	Factory Defaults		
	Adult	Pedi	Neo
Mode	Continuous	Continuous	Continuous
Repeat Time	15 min	15 min	15 min
Alarms	On	On	On
QRS Volume	1	1	1
Tone Modulation	Yes	Yes	Yes
Tone Mod. Type	Enhanced	Enhanced	Enhanced
Perfusion	On	On	On
Average	10 sec	10 sec	10 sec
NBP Alarm Suppr.	On	On	On
Extd. Auto OnOff	Disabled	Disabled	Disabled
Color	Cyan (light blue)	Cyan (light blue)	Cyan (light blue)
Average in Mon.	No	No	No
Signal Quality	On	On	On

SpO ₂ Alarm Default Settings			
Setting	Adult	Pedi	Neo
Desat Limit	80	80	80
Low Limit	90	90	85
High Limit	100	100	95
Desat Delay	20 sec	20 sec	20 sec
High Alarm Delay	10 sec	10 sec	10 sec
Low Alarm Delay	10 sec	10 sec	10 sec
SmartAlarmDelay (SAD)	Off	Off	Off
High Alarm Delay (SAD)	Short	Short	Short

SpO ₂ Alarm Default Settings			
Setting	Adult	Pedi	Neo
Low Alarm Delay (SAD)	Short	Short	Short
Label	SpO ₂	SpO ₂	SpO ₂
Pulse settings			
Pulse (SpO ₂)	On	On	On
For all other Pulse default settings, refer to the Pulse Default Settings table.			

NBP Default Settings

NBP Settings	Factory defaults H10/H20/H30			H30 (deviations from H10/H20/H40)		
	Adult	Pedi	Neo	Adult	Pedi	Neo
Mode	Auto	Auto	Manual			
Alarms from	Sys.	Sys.	Sys.			
High Limit	160/90 (110)	120/70 (90)	90/60 (70)	180/90 (110)		
Low Limit	90/50 (60)	70/40 (50)	40/20 (24)	70/50 (65)		
Alarms	On	On	On			
NBP	On	On	On			
Repeat Time	10 min	10 min	10 min	3 min	3 min	3 min
Pulse (NBP)	On	On	On			
Unit	mmHg	mmHg	mmHg			
Done Tone	Off	Off	Off	On	On	
Start Time	Synchronized	Synchronized	Synchronized	NotSynchron.	NotSynchron.	NotSynchron.
VP Pressure	60 mmHg	40 mmHg	30 mmHg			
Reference	Auscultatory	Auscultatory	Invasive			
Aging Time	10 min	10 min	10 min			
Color	Red	Red	Red	Magenta	Magenta	Magenta

Temperature Default Settings

Temp Settings	Factory defaults H10/H20/H40			H30 (deviations from H10/H20/H40)		
	Adult	Pedi	Neo	Adult	Pedi	Neo
Low Limit	36	36	36	35	35	35
High Limit	39	39	39			
Alarms	On	On	On			
Unit	°C	°C	°C			
Range	35...43	35...43	35...43			
Color	Green	Green	Green	Light Green	Light Green	Light Green

Invasive Pressure Default Settings

ABP, P, P1, P2, P3, P4, UAP, ART, Ao, FAP, BAP Settings	Factory defaults H10/H20/H40			H30 (deviations from H10/H20/H40)		
	Adult	Pedi	Neo	Adult	Pedi	Neo
Alarms from	Sys.	Sys.	Sys.			
High Limit	160/90 (110)	120/70 (90)	90/60 (70)	180/90 (110)		
Low Limit	90/50 (70)	70/40 (50)	55/20 (36)	70/50 (70)		
Alarms	On	On	On			
Extreme Alarms	Disabled	Disabled	Disabled			
Δ Extreme High	15	10	5			
Δ Extreme Low	15	10	5			
Sys. High Clamp/Dia. High Clamp (Mean High Clamp)	190/100 (125)	140/80 (100)	105/75 (75)			
Sys. Low Clamp/Dia. Low Clamp (Mean Low Clamp)	80/45 (65)	60/35 (45)	45/15 (30)	65/45 (65)		
Scale	150	100	100			
Mean only	No	No	No			
Filter	12 Hz	12 Hz	12 Hz			
Mercury Cal	Yes	Yes	Yes			
Artifact Suppr.	60 sec	60 sec	60 sec			
Unit	mmHg	mmHg	mmHg			
Color	Red	Red	Red			
Pulse settings for all arterial pressures except P1 to P4						
Pulse (<Press Label>)	On	On	On			

For all other Pulse default settings, refer to the Pulse Default Settings table.

CVP, RAP, LAP, UVP Settings	Factory defaults H10/H20/H40			H30 (deviations from H10/H20/H40)		
	Adult	Pedi	Neo	Adult	Pedi	Neo
Alarms from	Mean	Mean	Mean			
High Limit	14/6 (10)	10/2 (4)	10/2 (4)			
Low Limit	6/-4 (0)	2/-4 (0)	2/-4 (0)			
Alarms	On	On	On			
Extreme Alarms	Disabled	Disabled	Disabled			
Δ Extreme High	5	5	5			
Δ Extreme Low	5	5	5			
Sys. High Clamp/ Dia. High Clamp (Mean High Clamp)	20/10 (15)	15/5 (10)	15/5 (10)			
Sys. Low Clamp/Dia. Low Clamp (Mean Low Clamp)	0/-5 (-5)	0/-5 (-5)	0/-5 (-5)			
Scale	30	30	30			

41 Default Settings Appendix

CVP, RAP, LAP, UVP Settings	Factory defaults H10/H20/H40			H30 (deviations from H10/H20/H40)		
	Adult	Pedi	Neo	Adult	Pedi	Neo
Mean only	Yes	Yes	Yes			
Filter	12 Hz	12 Hz	12 Hz			
Mercury Cal	Yes	Yes	Yes			
Artifact Suppr.	60 sec	60 sec	60 sec			
Unit	mmHg	mmHg	mmHg			
Color	Cyan (light blue)	Cyan (light blue)	Cyan (light blue)	Blue	Blue	Blue

PAP Settings	Factory Defaults		
	Adult	Pedi	Neo
Alarms from	Dia.	Dia.	Dia.
High Limit	34/16 (20)	60/4 (26)	60/4 (26)
Low Limit	10/0 (0)	24/-4 (12)	24/-4 (12)
Alarms	On	On	On
Extreme Alarms	Disabled	Disabled	Disabled
Δ Extreme High	5	5	5
Δ Extreme Low	5	5	5
Sys. High Clamp/Dia. High Clamp (Mean High Clamp)	45/20 (25)	65/5 (35)	65/5 (35)
Sys. Low Clamp/Dia. Low Clamp (Mean Low Clamp)	5/-5 (-5)	15/-5 (5)	15/-5 (5)
Scale	30	30	30
Mean only	No	No	No
Filter	12 Hz	12 Hz	12 Hz
Mercury Cal	Yes	Yes	Yes
Artifact Suppr.	60 sec	60 sec	60 sec
Unit	mmHg	mmHg	mmHg
Color	Yellow	Yellow	Yellow

ICP, IC1, IC2 Settings	Factory Defaults		
	Adult	Pedi	Neo
Alarms from	Mean	Mean	Mean
High Limit	14/6 (10)	10/2 (4)	10/2 (4)
Low Limit	6/-4 (0)	2/-4 (0)	2/-4 (0)
Alarms	On	On	On
Extreme Alarms	Disabled	Disabled	Disabled
Δ Extreme High	10	10	10
Δ Extreme Low	10	10	10
Sys. High Clamp/Dia. High Clamp (Mean High Clamp)	20/10 (15)	15/5 (10)	15/5 (10)

ICP, IC1, IC2 Settings	Factory Defaults		
	Adult	Pedi	Neo
Sys. Low Clamp/Dia. Low Clamp (Mean Low Clamp)	0/-5 (-5)	0/-5 (-5)	0/-5 (-5)
Scale	30	30	30
Mean only	Yes	Yes	Yes
Filter	12 Hz	12 Hz	12 Hz
Mercury Cal	Yes	Yes	Yes
Artifact Suppr.	60 sec	60 sec	60 sec
Unit	mmHg	mmHg	mmHg
Color	Magenta	Magenta	Magenta

Cardiac Output Default Settings

C.O. Settings	Factory defaults H10/H20/H40			H30 (deviations from H10/H20/H40)		
	Adult	Pedi	Neo	Adult	Pedi	Neo
Auto-Calibration	On	On	On			
Tblood HighLimit	39.0°C	39.0°C	39.0°C			
Tblood Low Limit	36.0°C	36.0°C	36.0°C			
Tblood Alarms	On	On	On			
Temperature Unit	°C	°C	°C			
Color	Green	Green	Green	Yellow	Yellow	Yellow

CCO/CCI Settings	Factory Adult	Factory Pedi	Factory Neo
Settings common to CCO and CCI			
Alarms from	CCO	CCO	CCO
CCO from	ABP	ABP	ABP
Color	Green	Green	Green
CCO			
Alarms	On	On	On
CCO High Limit	8.5 l/min	3.7 l/min	1.3 l/min
CCO Low Limit	4.0 l/min	2.6 l/min	0.3 l/min
CCI			
Alarms	On	On	On
CCI High Limit	4.3 l/min/m ²	4.3 l/min/m ²	5.2 l/min/m ²
CCI Low Limit	2.0 l/min/m ²	2.6 l/min/m ²	1.2 l/min/m ²

CO₂ Default Settings

CO ₂ Settings	Factory defaults H10/H20/H40			H30 (deviations from H10/H20/H40)		
	Adult	Pedi	Neo	Adult	Pedi	Neo
etCO ₂ Low	30	30	30	25	25	25
etCO ₂ High	50	50	50	60	60	60
imCO ₂ High	4	4	4			
CO ₂ Alarms	On	On	On			
Unit	mmHg	mmHg	mmHg			
Scale	40 mmHg	40 mmHg	40 mmHg	50	50	50
imCO ₂	On	On	On	Off	Off	Off
N ₂ O Corr. (only M3015A/M3016A)	Off	Off	Off			
Oxygen Corr. (only M3014A)	16%	16%	16%			
Gas Corr. (only M3014A)	Off	Off	Off			
Humidity Corr.	BTPS	BTPS	BTPS			
Max Hold	Off	Off	Off			
awRR	On	On	On			
awRR Alarms	On	On	On			
High Limit (awRR)	30	30	60			
Low Limit (awRR)	8	8	30			
Apnea Time	20 sec	20 sec	20 sec			
IPI	On	On				
Low Alarm (IPI)	On	On				
Color	Yellow	Yellow	Yellow	White	White	White

Spirometry Default Settings

Spirometry Settings	Factory Adult	Factory Pedi	Factory Neo
Apnea Time	20	20	20
MVexp Low	4.0 l/min	2.5 l/min	0.4 l/min
MVexp High	8.0 l/min	4.0 l/min	0.8 l/min
PIP High	40	25	20
PEEP Low	0	0	0
PEEP High	25	25	25
High Limit (RRspir)	8	8	30
Low Limit (RRspir)	30	30	60
Scale (AWF)	±150 l/min	±100 l/min	±20 l/min
Scale (AWV)	±800 ml	±200 ml	±50 ml
Scale (AWP)	±40 cmH ₂ O	±40 cmH ₂ O	±20 cmH ₂ O

tcGas Default Settings

tcGas Settings	Factory Adult	Factory Pedi	Factory Neo
tcpO ₂ High Limit	80 mmHg	80 mmHg	80 mmHg
tcpO ₂ Low Limit	50 mmHg	50 mmHg	50 mmHg
tcpO ₂ Alarms	On	On	On
tcpCO ₂ HighLimit	50 mmHg	50 mmHg	50 mmHg
tcpCO ₂ Low Limit	30 mmHg	30 mmHg	30 mmHg
tcpCO ₂ Alarms	On	On	On
Site Timer	4.0 hours	4.0 hours	4.0 hours
Disable Timer	Not Allowed	Not Allowed	Not Allowed
Heat Switch Off (i.e., after Site Timer elapsed)	No	No	No
Transducer Temp.	43.0°C	43.0°C	43.0°C
CO ₂ Correction (<i>Severinghaus</i>)	On	On	On
MetabolismFactor	8 mmHg	8 mmHg	8 mmHg
tcGas Unit	mmHg	mmHg	mmHg
Temperature Unit	°C	°C	°C
tcpO ₂ Color	Blue	Blue	Blue
tcpCO ₂ Color	Green	Green	Green

Intravascular Oxygen Saturation Default Settings

SO ₂ Settings	Factory Adult	Factory Pedi	Factory Neo
Low Limit	70%	70%	70%
HR High Limit	80%	80%	80%
Alarms	On	On	On
Light Intensity	On	On	On
Color	Yellow	Yellow	Yellow
Hb/Hct Entry	Hct [%]	Hct [%]	Hct [%]
Factor Entry	Disabled	Disabled	Disabled

SvO ₂ Settings	Factory Adult	Factory Pedi	Factory Neo
Low Limit	60%	60%	60%
High Limit	80%	80%	80%
Alarms	On	On	On
Light Intensity	On	On	On
Color	Yellow	Yellow	Yellow
Hb/Hct Entry	Hct [%]		
Factor Entry	Disabled		

ScvO ₂ Settings	Factory Adult	Factory Pedi	Factory Neo
Low Limit	70%	70%	70%
High Limit	80%	80%	80%
Alarms	On	On	On
Light Intensity	On	On	On
Color	Yellow	Yellow	Yellow

SvO₂ Default Settings

SvO ₂ Settings	Factory Adult	Factory Pedi	Factory Neo
Low Limit	60%	60%	60%
High Limit	80%	80%	80%
Alarms	On	On	On
Light Intensity	On	On	On
Color	Yellow	Yellow	Yellow
Hb/Hct Entry	Hct [%]		
Factor Entry	Disabled		

ScvO₂ Default Settings

ScvO ₂ Settings	Factory Adult	Factory Pedi	Factory Neo
Low Limit	70%	70%	70%
High Limit	80%	80%	80%
Alarms	On	On	On
Light Intensity	On	On	On
Color	Yellow	Yellow	Yellow

EEG Default Settings

EEG Settings	Factory Adult	Factory Pedi	Factory Neo
TP, SEF	On	On	On
MDF, PPF, Delta, Theta, Alpha, Beta	Off	Off	Off
SEF Threshold	90%	90%	90%
Numeric Average	8 sec	8 sec	8 sec
Wave Scale	100 μ V (or \pm 50 μ V if Show Gridlines is configured to Yes)		
Show Gridlines	No	No	No
Low Filter	0.5 Hz	0.5 Hz	0.5 Hz
High Filter	30 Hz	30 Hz	30 Hz
Impedance Limit	5 kOhm	5 kOhm	5 kOhm
Smoothing CSA	On	On	On

EEG Settings	Factory Adult	Factory Pedi	Factory Neo
Color	Yellow	Yellow	Yellow

BIS Default Settings

BIS Settings	Factory defaults H10/H20/H40			H30 (deviations from H10/H20/H40)		
	Adult	Pedi	Neo	Adult	Pedi	Neo
SQI	On	On	On			
EMG	On	On	On			
SR	On	On	On			
SEF	Off	Off	Off			
TP	Off	Off	Off			
Bursts	On	On	On	Off	Off	Off
Scale	100 μ V (or +/- 50 μ V if Show Gridlines is configured to Yes)					
Show Gridlines	No	No	No			
Filters	On	On	On			
Low Filter	2 Hz	2 Hz	2 Hz			
High Filter	70 Hz	70 Hz	70 Hz			
Notch Filter	On	On	On			
High Limit	70	70	70			
Low Limit	20	20	20			
Alarms	On	On	On			
Show ImpedValues	Off	Off	Off			
Smoothing Rate	30 sec	30 sec	30 sec	15 sec	15 sec	15 sec
Color	Yellow	Yellow	Yellow	Magenta	Magenta	Magenta

NMT Default Settings

NMT Settings	Factory Adult	Factory Pedi	Factory Neo ¹
Stimulation	TOF	TOF	TOF
Mode	Manual	Manual	Manual
Repeat Time TOF	30 sec	30 sec	30 sec
Repeat Time Twitch	12 sec	12 sec	12 sec
Current	50 mA	50 mA	50 mA
Pulse Width	200 μ sec	200 μ sec	200 μ sec
Alarms	Off	Off	Off
Suppress Alarms	On	On	On
TOFcnt High Lim	3	3	3
Stimul. Modes	TOF/PTC	TOF/PTC	TOF/PTC
Value Lifetime	5 min	5 min	5 min

NMT Settings	Factory Adult	Factory Pedi	Factory Neo ¹
Color	Light Green	Light Green	Light Green
<small>¹The NMT Measurement may not be used for neonatal patients and is therefore not supported in the neonatal mode.</small>			

VueLink Default Settings

VueLink Settings	Factory defaults
Device Alarms	Ignored
Color	Green

Index

#

- 10-lead placement (ECG) 142
- 12-lead placement (ECG) 142
- 3-lead placement (ECG) 140
- 4-slot flexible module rack 19
- 5-lead placement (ECG) 141
- 8-slot flexible module rack 19

A

- AAMI ECG lead labels 139
- abdominal breathing 186
 - and Resp electrode placement 186
- aberrantly conducted beats 156
- accessories 242, 256
 - 10-electrode cable sets 421
 - 3-electrode cable sets 420, 422
 - 5-electrode cable sets 420, 422
 - 6-electrode cable sets 420
 - C.O. 228, 230, 233, 247, 436
 - CO2 243, 247, 248, 249
 - CO2 (mainstream) 437, 438
 - CO2 (microstream) 438
 - ECG 133
 - Hospira Inc. 440
 - NBP 423
 - adult cuffs 425
 - comfort cuffs 423
 - disposable cuffs 425
 - multi-patient comfort cuff kits 423
 - neonatal/infant cuffs (single patient) 426
 - reusable cuffs 423
 - single patient, adult/pediatric soft cuffs 425
 - Nellcor 429
 - pressure 426
 - Pulsion 426
 - resp 419
 - set combiners and organizers 421, 423
 - SpO2 191, 192, 429
 - Nellcor adhesive sensors (disposable) 429
 - Philips sensors (disposable) 429
 - Philips sensors (reusable) 429
 - SvO2 273, 274, 441
 - temperature 435
 - trunk cables 419, 422
- active alarms 59
- address, Philips 444
- addressograph (printer configuration setting) 376
- adjusting ST measurement points 168
- adjusting wave scale (pressure) 217
- adjusting wave size (CO2) 250, 260
- admitting a patient
 - editing information 109
 - quick admit 108
- advanced event surveillance 333
- airway adapter 249
 - CO2, microstream accessory 249
- alarm latching 72, 161
- alarm limits 67, 68, 70, 377
 - changing 37
 - checking 67
 - manually adjusting 68
 - narrow 70
 - report 312
 - setting 67
 - ST 171
 - switching auto limits on/off 70
 - using automatic limits 70
 - wide 70
 - window 68
- alarm recording 360
- alarm source selection, disabled 183
- alarms 59
 - acknowledging 63
 - active 59
 - active SpO2 source 201
 - alphabetical listing 75
 - apnea delay 251, 260
 - apnea delay time (Resp) 188
 - arrhythmia 154
 - audible indicators 61
 - awrr limits 252
 - chaining 162
 - CO2 specific 251
 - CO2, apnea delay 251, 260
 - CO2, awRR 252
 - desat, SpO2 200
 - effect on pressure alarms during zero 215
 - extending pause time 66
 - high priority 59
 - INOP 59
 - ISO/IEC standard 62
 - limit, SpO2 479
 - NBP source 209
 - patient messages 75
 - pausing 64
 - physiological 75
 - pleth as source 200
 - recordings 73
 - red 59
 - restarting 66
 - reviewing 71
 - reviewing messages 71
 - reviewing window 71
 - selftest 73
 - silencing 63
 - SpO2 high and low limits 199
 - SpO2 specific 194
 - ST 171
 - suspended symbol 66
 - SvO2, behavior during measurement 272
 - switching on and off 41
 - temperature 211
 - testing 73
 - tone configuration 62
 - traditional 62
 - volume, changing 62
 - VueLink and external devices 389
 - yellow 59
- alphabetical listing of alarms 75
- analog output 447
 - ECG 133
 - pressure 213
- annotating events 342
- annotation 342
- apnea alarm delay 251, 260
- apnea alarm delay time (RESP) 188
- apnea alarms 188
 - and Resp detection modes 187
- arrhythmia 154
 - aberrantly conducted beats 156
 - analysis, how it works 154
 - atrial fibrillation and flutter 155
 - beat labels 157
 - initiating learning 159, 160
 - intermittent bundle branch block 156
 - learning during ventricular rhythm 160
 - levels of analysis 149, 154
 - monitoring non-paced patients 155
 - monitoring paced patients 155
 - options 154
 - relearning 159
 - relearning and lead fallback 160
 - status messages 157
 - switching on/off 70
 - understanding the display 156

- arrhythmia alarms 59, 160, 161, 162, 164, 475
 - adjusting alarm limits 161
 - all yellow on/off 161
 - chaining 162
 - latching 72
 - multiple 162
 - PVC-related alarms 164
 - sinus and SV rhythm ranges 478, 479
 - switching on/off 70
 - timeout periods 161
- arrhythmia monitoring 152
 - and defibrillation 152
- arrhythmia options 149
- arrhythmia relearning 145
 - with EASI INOP 145
- arterial catheter constant (PiCCO) 230
- arterial pressure source 221
- arterial pulsation 191
- arterial values 263
- artifact suppression (pressure) 218
- Aspect Medical Systems Inc 445
- atrial fibrillation and flutter 155
- audible latching (arrhythmia alarms) 161
- auto alarm limits 70
 - switching on/off 70
- auto detection mode (Resp) 186
- auto ECG wave gain (recordings) 362
- auto window (care groups) 131
- autofilter 137
- automatic arrhythmia relearn 159
- automatic default setting 41
- automatic NBP 208
 - repeat time 206
- autosize 137
 - ECG wave 136
- average trend events 334
- awRR alarms 252
 - limits 252

B

- balloon inflation, wedge measurement 222
- baseline 168, 174
 - ST map, updating 174
 - ST, updating 168
- basic arrhythmia option 149, 154
- basic event surveillance 333, 338
 - setup 230
- beat labels 157
 - arrhythmia 154
- BIS 285
 - Continuous Impedance Check 288
 - Cyclic Impedance Check 288
 - filters 290
 - Ground Check 288

- impedance indicators 289
 - monitoring 36
 - monitoring setup 286
 - numerics 206
 - on/off 290
 - safety information 152, 188, 239
 - smoothing rate 290
 - changing 37
 - window 68
- blood pressure. See also NBP (non-invasive) or PRESS (invasive) 203
- BSA formula (trends) 328
- buffer (EEG) on reports 284
- buffer (EEG) on screen 282

C

- C.I. 226
- C.O. 225
 - accessories 242, 256
 - calibrating measurements (PiCCO) 232
 - curve alert messages 236
 - documenting measurements 235
 - editing measurements (PiCCO) 232
 - editing measurements (RH method) 235
 - flow-through method 233
 - hemocalc window 228
 - hemodynamic parameters available 226
 - injectate guidelines 235
 - PiCCO method 228
 - Procedure window 226
 - prompt messages 238
 - results table 226
 - right heart thermodilution method 233
 - saving measurements (PiCCO) 232
 - setup for PiCCO method 230
 - setup for RH method 233
 - temperature unit 226
 - warning messages 238
- C.O./CCO safety information 239
- Calc Type 326
- calculating 381
 - drug infusions 381
- calculating cerebral perfusion 221
- calculating oxygen extraction 277
- calculating pulse pressure variation 221, 229
- calculating temperature difference 212
- calculations 325, 326
 - pop-up keys 33, 335
- calculations reports 329
- calculations review 327
- calculator 35
- calibrating 210
 - CO2 transducer 247
 - tcGas transducer 265
- calibrating C.O. measurements 232
- calibration 210, 219, 273, 274, 276
 - NBP 210
 - pressure 219
 - pressure transducer 219
 - SvO2 light intensity 274
 - SvO2, pre-insertion 273
- calibration status indicators (C.O) 232
- capnography 25
 - mainstream 25
 - Microstream 25
- capturing loops 400
- carbon dioxide, see CO2 241, 255
- cardiac output 225, 378
 - how the measurement works 203
 - report 312
- cardiac overlay 185, 187
 - and Resp detection modes 187
 - when measuring Resp 185
- cardiotach alarms 149
- care groups 131
 - alarm notification 131
 - pop-up window 131
- catheter 274
 - SvO2, insertion 274
- catheter constant, setting (PiCCO) 230
- catheter preparation 273
 - SvO2 271
- CCO 225, 228, 230, 232
 - calibration status indicators 232
 - choosing the correct pressure source 230
 - how the measurement works 203
 - PiCCO method 228
- cerebral perfusion 221
- CFI 226
- chaining 162
- change screen menu 37
- changing 37
- changing ECG lead sets 139
- changing EEG wave scale 283
- changing EEG wave speed 283
- changing Resp detection mode 186
- changing Resp wave size 187
- changing Resp wave speed 188
- changing screen content 37
- changing screens 37
- changing wave scale 283
- checking battery charge 407
- checking paced status 134
- cleaning 411
 - infection control 411
 - method 412
 - monitoring accessories 413
 - recommended substances 412

recorder printhead 413
clock 397
 displaying on main screen 397
CO2 241
 airway adapter 249
 alarms, apnea delay 251, 260
 alarms, awRR 252
 alarms, specific 251
 awRR alarm limits 252
 checking transducer accuracy 247
 correction, humidity 250
 correction, N2O 250
 corrections 250, 260
 FilterLine 249
 mainstream accessories 242, 256
 measuring mainstream 243, 247
 measuring microstream 249
 method, mainstream 241
 method, microstream 241
 method, sidestream 241
 microstream accessories 249
 microstream extension 248
 removing exhaust gases 246, 250
 transducer, calibrating 247
 transducer, using 247
 troubleshooting 417
 wave scale, adjusting 250, 260
CO2 (mainstream) 437, 438
 accessories 242, 256
CO2 (microstream) 438
 accessories 242, 256
combi-events 340
computation constant (RH) 234
configuration 36
 drug calculator 381
 trends database 319
configuration mode 36
conflict 44
 label 44
connecting BIS accessories 286
connecting temperature probe 211
connection direction symbol 445
connectors 447
continuous cardiac output 225
Continuous Impedance Check (BIS) 288
conventional 12-lead ECG 143
correcting the NBP measurement 205
counting events 340
CPAP (RESP) 186
cuff 205, 206
 pressure, NBP 206
 selection, NBP 205
current view 172
 ST map 172
curve alert messages (C.O.) 236

Cyclic Impedance Check (BIS) 288

D

database 339
 events 334
 trends 319
date, setting 47
default profile 40
default settings 501
defibrillation 152, 284
 and arrhythmia monitoring 152
 and ECG monitoring 152
 during EEG monitoring 284
delayed recording 360
deleting events 339
demonstration mode 36
desat alarm, SpO2 200
detection modes (Resp) 186
device driver 390, 393
 language conflict with monitor 390, 393
diagnostic (ECG filter setting) 137
disabling touch operation 30
disconnect INOPs 64
 silencing 63
disinfecting 411
 infection control 411
 recommended substances 412
display 156, 166, 186, 206
 ECG 134
 NBP 206
 Resp 186
 ST 166
display settings 39
disposal 417
 gas cylinder 417
 parts and accessories 417
documenting events 342
dosemeter (drug calculator) 384
dPmax 226
drip table (drug calculator) 385
drug calculator 381
dual SpO2 201
dual Temp measurement 212
dyshemoglobins 192
 intravascular (SpO2) 192

E

early systolic blood pressure, NBP 206
EASI 138, 145
 activating 138
 ECG monitoring 145
 lead placement 138, 185
EASI ECG lead labels 139

ECG 133

 accessories 242, 256
 alarms off (Config Mode) 152
 changing lead sets 139
 choosing electrode sites 138
 conventional 12-lead 143
 external pacing electrodes 152
 filter settings 137
 fusion beat pacemakers 152
 intrinsic rhythm 152
 modified 12-lead 143
 New Lead Setup 139
 pacemaker failure 152
 rate adaptive pacemakers 152
 unfiltered 137
 wave size 136
ECG analog output 447
ECG cable 152
 for operating room 152
ECG cables, connecting 133
ECG connector 133
ECG electrode colors 139
ECG electrode placement 152
 during electrosurgery 152
ECG gain 362, 371
 in reports 332
ECG lead labels 139
ECG lead placement 138
 choosing EASI/Standard 138
ECG leads monitored 139
ECG report 371, 379
 lead layout 371
ECG safety information 152
ECG source tracking 124
ECG wave 136
 autosize 137
 calibration bar 137
ectopic status messages (arrhythmia monitoring) 158
editing C.O. measurements (PiCCO method) 232
editing C.O. measurements (RH methods) 235
EEG
 accessories 242, 256
 monitor configuration and upgrade 284
EEG monitoring
 changing filter frequencies 283
 changing wave scale 283
 changing wave speed 283
 electrode-to-skin impedance 281
 gridlines 283
 impedance quality indicators 281
 safety information 152, 188, 239
 setting report buffer time 284
 setting screen buffer time 282

- setup 230
- skin preparation 133
- switching numerics on and off 283
- EEG wave 290
 - changing scale 290
- electrical interference
 - during EEG monitoring 284
- electrode placement (ECG) 133, 143
 - conventional 12-lead 143
 - modified 12-lead 143
- electrode placement (Resp) 185, 186
 - with abdominal breathing 186
 - with lateral chest expansion 186
- electrode-to-skin impedance (BIS) 289
- electrode-to-skin impedance (EEG) 281
- electrosurgery 152
 - and ECG 152
- EMC interference 188
 - Resp 186
- EMI filter for ECG 137
- end case reports 372
 - setup 230
- enhanced arrhythmia option 149, 154
- entering values 328
 - calculations 325, 326
- event database 339
- event episode reports 372
- event groups 334
- event report 346
- event review reports 372
- event snapshots 334
- event surveillance 333
 - options 154
- events 333
 - annotation 342
 - combi-events 340
 - counting oxyCRG/NER events 340
 - event counter 340
 - event episode 334
 - event episode recording 344
 - event episode types 334
 - event episode window 342
 - event post-time 334
 - event pre-time 334
 - event retriggering 337
 - event review recording 343
 - event review window 341
 - event summary view 340
 - event time 334
 - event triggers 336
 - event values 342
 - manual event triggers 339
 - setting up NER 338
- events pop-up keys 335
- EVLW/EVLWI 226

- exhaust gases, removing 246, 250
- extension cable for SpO2 192
- external devices 387, 388, 389
 - alarms and INOPS 389
 - connecting to VueLink 387
 - connecting via VueLink 388
- external pacing electrodes 152
 - and ECG monitoring 152
- extreme bradycardia alarm 151, 183
- extreme pressure alarms 218
- extreme rate alarms 151, 183
- extreme tachycardia alarm 151, 183

F

- fallback (ECG) 139
- FAST 191
 - Fourier artefact suppression technology 191
- filter (ECG filter setting) 137
- filter (ECG) 137
- filter frequencies (EEG) 283
- FilterLine 249
 - CO2, microstream accessory 249
- filters 290
 - BIS 290
- flexible module rack 19
- flushing invasive pressure accessories 213
- FMS-4 19
- FMS-8 19
- functional arterial oxygen saturation 191
- fusion beat pacemakers 152
 - and ECG monitoring 152

G

- gas cylinder 417
 - empty, disposing of 418
- GEDV/GEDVI 226
- getting started 48
- global trend time 320
- graphic trend 312
 - report 312
- graphic trends 313
- graphic trends report 319
- gridlines (EEG) 283, 290
- Ground Check (BIS) 288

H

- hardkeys 33
- help 71
 - INOPS 71
- hemodynamic calculations 325
- hemodynamic measurement module

- extension 27
- hemodynamic parameters 226
- high filter (EEG) 283
- high pass filter (BIS) 290
- high resolution recording 360
- high-res trend event episodes 334
- high-res trend waves 331
 - about 41
 - OxyCRG 331
- high-res waves 332
 - in reports 332
 - recordings 73
- HiResTrnd 334
 - see high-res trend 334
- horizon trend 320
 - trend time 320
- HR = RR (Resp) 186
- HR alarms 152
 - when arrhythmia off 152
- HR alarms off (Config Mode) 152
- HR and pulse alarm source selection 183
- HR from (heart rate source) 182
- humidity correction 250
- hypotension evaluation 352

I

- IEC ECG lead labels 139
- impedance indicators (BIS) 289
- impedance quality indicators 281
- IMV (Resp) 186
- infection control 411
 - cleaning 411
 - disinfecting 411
 - sterilizing 411
- Information Center 113, 114
 - transferring patients 113, 114
 - transferring patients using IIT 114
- injectate guidelines for C.O. 235
- injectate volume setting (C.O.) 230
- INOPs 59, 64, 389
 - from external devices 389
 - indicators 59
 - silencing 63
- installation 447
 - connectors 447
- integrated PC 50
- intermittent bundle branch block 156
- intermittent mandatory ventilation (Resp) 186
- intravascular dyshemoglobins (SpO2) 192
- intrinsic rhythm 152
- invasive pressure 213
- in-vivo calibration, SvO2 274, 276

iPC 50
 desktop 51
 input devices 51
 shutting down 52
ISO point (ST) 169
ITBV/ITBVI 226

J

J point (ST) 169

K

keys 30, 33
 hardkeys 33
 permanent keys 30
 pop-up 33

L

label conflict resolution 44
labels 44
 resolving conflict 44
lactate measurement 352
language conflicts with device driver 390
latching 72
 alarms, behavior 72
latching arrhythmia alarms 161
lateral chest expansion (neonates) 186
 monitoring Resp 186
LCW/LCWI 226
lead fallback 160
 and arrhythmia relearning 160
lead fallback (ECG) 139
lead labels (ECG) 139
lead placement 138, 185
 activating EASI/Standard 138
 for Resp measurement 185
leads monitored (ECG) 139
Leads Off INOP (ECG) 139
levels of arrhythmia analysis 154
levels of event surveillance 333
line frequency interference (BIS) 290
loops 399, 400, 401
 capturing 400
 loop size in window 400
 loops report 401
 source device 401
 volume-flow 399
low filter (EEG) 283
low pass filter (BIS) 290
LVCI 226

M

M8048A 19
mainstream 25

 capnography 25
mainstream CO2 242, 247, 256
 accessories 242, 256
 measuring 243, 247
maintenance 415
 schedule 415
 visual inspection 415
management bundle recommendations 354
manual detection mode (Resp) 187, 188
 and apnea alarms 188
manually triggering events 339
manufacturer's information 444
map 172
 ST 172
Mason-Likar lead system 143
max hold setting (CO2) 241
mean pressure calculation (trends) 328
measurement 41, 42
 setting up 41
 switching on and off 41
 wave speed, changing 42
measurement module extension 25, 27
 M3012A 27
 M3015A 25
 M3016A 25
measurement modules 48
measurement points, ST 168
measurement selection window 44
measurement settings 39
merging patient data 118
methemoglobin (SpO2) 192
Microstream capnography 25
microstream CO2 248, 249
 accessories 242, 256
 measuring 243, 247
mismatch 117
 patient data, resolving 117
MMS 115
 using for patient transfer 115
modified 12-lead ECG 143
modified screen history 37
modifying 37
 screens 37, 39
module 263, 387, 391
 tcGas 263
 VueLink 387
 VueLink Type A and Type B 387
monitor 49
 starting monitoring 49
monitor (ECG filter setting) 137
monitor defaults 501
monitor revision 48
 how to find 48

monitor settings 39
 changing 37
monitoring 36
monitoring mode 36
mouse 30
 using 30
multi-measurement module 133
 ECG connector 133

N

N2O correction 250
narrow alarm limits 70
navigating 30
 mouse 30
 permanent keys 30
 trackball 30
NBP 203
 adult cuffs 425
 alarm source 209
 ANSI/AAMI SP10-1992 203
 automatic mode, enabling 208
 calibrating 210
 comfort cuff kits 423
 comfort cuffs 423
 cuff pressure 206
 cuff, applying 205
 cuff, selecting 205
 cuff, tightness 205
 disposable cuffs 425
 how the measurement works 203
 measurement correction 205
 measurement limitations 204
 measurement methods, auto 204
 measurement methods, manual 204
 measurement methods, sequence 204
 measurement methods, stat 204
 measurement, starting 207
 measurement, stopping 207
 neonatal cuffs (disposable) 426
 numerics 206
 oscillometric method 203
 pediatric cuffs 425
 preparing to measure 205
 repeat time 206
 repeat time for automatic 208
 repetition time, setting 208
 reusable cuffs 423
 single patient, adult/pediatric soft cuffs 425
 site inspection 192
 time of last measurement 206
 units 206
 venous puncture 210
neonatal event counting 340
neonates 186
 Resp electrode placement 186
NER setup 338

non-invasive blood pressure. See NBP 203
non-paced patients 155
 arrhythmia monitoring 152
notch filter (BIS) 290
numerics 206
 explanation of NBP display 206
nurse call 66

O

on screen calculator 35
operating 30
 mouse 30
 permanent keys 30
 trackball 30
operating modes 36
 configuration 36
 demonstration 36
 monitoring 36
 passcode protection 36
 service 36
operating room ECG cable 152
orange ECG cable 152
organizers 421, 423
Oridion Systems Ltd 445
Original Calc pop-up key 327
oscillometric NBP measurement
 method 203
overlapping screen trends 321
oxyCRG 331, 340
 event counting 340
OxyCRG event episodes 334
oxygen extraction 277
oxygenation calculations 325

P

pace pulse rejection (ECG) 134, 136
 about 41
 switching on/off 70
paced patients 136, 152, 155
 arrhythmia monitoring 152
 repolarization tails 136
 safety information 152, 188, 239
 setting status 152
paced status 134
 checking 67
pacemaker failure 152
paper size 372
 for reports 372
parameter scales 317
 trends 317
passcode protection 36
patient 203
 category, NBP 203
patient alarm messages 75

patient mismatch 117
patient reports 376
 contents 376
patient trends 311
 viewing 311
paused alarms 64, 66
 extending time 66
 restarting 66
PAWP 222
performance specifications 475
performance test 495
performing calculations 327
perfusion indicator 191, 192, 200
pf loops 399
Philips contact information 444
physiological alarms 59
PiCCO method 228
 C.O. 228
 CCO 228
 setup 230
pleth alarm source 200
pleth wave 200
pleth waveform 191
pop-up keys 33, 335
 events 334
power 49
 disconnecting from 49
 mains power 49
 disconnecting from 49
PPV 221, 229
preparing skin 133
 for ECG 133
pressure 213
 alarms during zero 215
 arterial source 221
 calibration pressure 219
 cerebral perfusion, calculating 221
 performance specifications 475
 wave scale 217
 wave size 136
 wedge 222
 wedge, editing 223
 zeroing the transducer 215
pressure accessories 426
pressure analog output 224
pressure artifact suppression 218
pressure of NBP cuff 206
pressure transducer 215
 calibration 219
 zeroing 215
pressure-flow loops 399
pressure-volume loops 399
previous screen 37
primary lead (ECG) 134

 selecting 134
print job 374
 suspended 374
printer 373, 374, 375
 disabling 30
 settings 41, 125, 501
 status messages 157
 unavailable 374
printing 369
 C.O. measurements 235
 calculations reports 329
 event reports 342
 ST map reports 175
 status log 417
 trends reports 319
 wedge 222
priority list for trends 316
probes 211
 disposable temperature 211
profiles 39, 40
 default profile 40
 patient category 39
 swapping 40
 swapping setting block 40
protocol log 355
ProtocolWatch 349
 SSC sepsis 349
pulse 181, 182
 system pulse source 181
pulse numerics for SpO2 192
pulse pressure variation 221, 229
Pulsion Medical Systems AG 445
pv loops 399
PVC-related alarms 164
PVR/PVRI 226

Q

QRS tone pitch, SpO2 201
QRS volume, changing 137
QT alarms 178
QT baseline 177
QT measurement algorithm 175
QT monitoring 176
 limitations 176
QT/QTc monitoring 175
quick admit 108

R

radiated field immunity 188
 Resp 186
rate adaptive pacemakers 152
 and ECG monitoring 152
ratemeter (drug calculator) 384

- RCW/RCWI 226
 - realtime recording 360
 - realtime report 378
 - realtime reports 372
 - content 372
 - rear connectors 448
 - Recorder 357
 - reloading paper 364
 - recorder 413
 - cleaning the print head 413
 - recorder status messages 365
 - recording 357
 - alarm 62
 - annotation 342
 - beat-to-beat 360
 - C.O. measurements 235
 - context 360
 - delayed 360
 - drug calculations 386
 - ECG gain 362, 371
 - extending 359
 - high resolution 360
 - preventing fading ink 363
 - procedure 360
 - realtime 360
 - recording strip 362
 - recording strip code 363
 - ST segments 168
 - starting and stopping 359
 - types 360
 - wave scale 217
 - waveforms recorded 363
 - wedge 222
 - recording alarms 73
 - recording events 342
 - recording strip code 363
 - recycling 417
 - reference waves, wedge measurement 222
 - rejecting pace pulses 134
 - relearning arrhythmia 159
 - repolarization tails 136
 - report 312
 - cardiac output 225, 378
 - event review 346
 - reports 369
 - alarm limits 377
 - calculations 325, 326
 - choosing paper size 372
 - contents 376
 - drip table 386
 - drug calculator 381
 - ECG 133
 - loops 399, 400, 401
 - patient trends 311
 - realtime report 378
 - re-routing 374
 - scheduled 372
 - setting up 41
 - ST map 175
 - stopping printouts 371
 - titration table 386
 - trends 319
 - re-routing reports 374
 - resampling vitals 326
 - resolving patient mismatch 117
 - resp accessories 419
 - Resp alarms 188
 - apnea alarm delay time 188
 - Resp detection level 188
 - and apnea detection 188
 - Resp detection modes 186, 187
 - and cardiac overlay 185
 - changing 37
 - Resp display 186
 - Resp monitoring 185
 - and cardiac overlay 185
 - Resp safety information 188
 - Resp wave 187, 188
 - changing size 187
 - changing speed 42
 - respiratory loops 401
 - source device 401
 - restarting paused alarms 66
 - results table (C.O.) 226
 - resuscitation bundle recommendations 353
 - re-triggering events 337
 - retrolental fibroplasia (SpO₂) 199
 - review 327
 - calculations 325, 326
 - reviewing alarm messages 71
 - reviewing alarms 71
 - reviewing alarms window 71
 - RH method 234
 - computation constant 234
 - rhythm status messages (arrhythmia monitoring) 157
 - right heart thermodilution method (C.O.) 233
 - right heart thermodilution setup (C.O.) 233
 - rule of six 382
 - RVSW/RVSWI 226
- S**
-
- safety 456
 - monitor 49
 - safety information 152, 188, 239
 - BIS 291
 - C.O./CCO 239
 - ECG 133
 - Resp 186
 - safety test 495
 - same patient data merge 118
 - saving C.O. measurements (RH methods) 235
 - scale 136, 187
 - ECG wave 136
 - Resp wave 187, 188
 - scales 317
 - for trends waveforms 317
 - scheduled reports 372
 - screen 30
 - disabling touch operation 30
 - screen trend 320
 - trend time 320
 - screen trends 320
 - screening criteria 351
 - screens 37, 39
 - changing 37
 - changing content 37
 - understanding 37
 - visitor screen 39
 - secondary lead (ECG) 134
 - selecting 134
 - SEF numeric (BIS) 290
 - on/off 290
 - selecting the primary lead (ECG) 134
 - selecting the secondary lead (ECG) 134
 - selftest 73
 - sensor 191
 - disposable SpO₂ 191
 - sensor temperature 264
 - tcGas 263
 - sepsis management bundle 349, 354
 - recommendations 353
 - sepsis resuscitation bundle 349, 353
 - recommendations 353
 - sequence mode 208
 - service mode 36
 - set combiners 421, 423
 - setting the arterial catheter constant (PiCCO) 230
 - setting the computation constant (RH) 234
 - setting up 41
 - trends 311
 - setting up reports 371
 - setting up the sequence 208
 - settings 41, 125, 501
 - about 41
 - default 501
 - measurement settings 39
 - monitor settings 39
 - screen settings 41
 - synchronized telemetry and monitor 125

- settings blocks 39
- severe sepsis screening 349, 351
 - criteria 351
- short yellow alarms on/off 161
- signal quality of SpO2 194
- sinus and SV rhythm ranges 478, 479
- site timer 264
 - tcGas 263
- skin preparation 133
 - ECG 133
- smartkeys key 35
- smoothing rate (BIS) 290
- snapshots 334
 - events 334
- source device 401
 - loops 399, 400, 401
- source tracking 124
 - ECG 133
- specifications 475
 - arrhythmia 154
- speed 42
 - recording 360
 - wave speed, changing 42
- SpO2 191
 - accessories 429
 - active alarm source 200
 - alarms specific to SpO2 194
 - arterial pulsation 191
 - assessing suspicious reading 194
 - calculating difference between values 201
 - connecting the cables 192
 - disposable sensors 191
 - dual SpO2 201
 - extension cable 192
 - FAST technology 191
 - Nellcor adhesive sensors (disposable) 429
 - perfusion indicator 191, 192, 200
 - Philips sensors (disposable) 429
 - Philips sensors (reusable) 429
 - pleth as alarm source 200
 - pleth wave 200
 - pleth waveform 191
 - pulse numerics 192
 - signal quality 194
 - site inspection 192
 - tone modulation 201
- SpO2 desat alarm 200
- SpO2 limit alarms 199
- Sp-vO2 277
- SQI numeric 290
 - on/off 290
- SR numeric (BIS) 290
 - on/off 290
- SSC guidelines 349
- SSC sepsis 349
- ST 164
 - adjusting alarm limits 161
 - baseline, updating 168
 - ensuring diagnostic quality 164
 - filtering 164
 - measurement points, adjusting 168
 - snippets 166
- ST display 166
- ST map 172
 - baseline, updating 174
 - current view 172
 - report, printing (ST map) 175
 - scale, changing 174
 - task window 174
 - trend view 173
 - trending interval, changing 175
- ST maps 172
- ST point 169
- standard 10-lead placement 142
- standard 3-lead placement 140
- standard 5-lead placement (ECG) 141
- standardized rate 381
- starting monitoring 49
- status log 417
 - printing 417
- status messages 157
 - printer 373, 374, 375
 - recorder 413
- status messages (arrhythmia) 157, 158
 - ectopic 158
 - rhythm 157
- sterilizing 411
 - infection control 411
- stopping reports printouts 371
- surgical ECG cable 152
- surviving sepsis campaign 349
- suspended alarm 66
- suspicious SpO2 reading 194
- SV/SI 226
- SvO2 271
 - accessories 242, 256
 - catheter insertion 274
 - catheter preparation 273
 - in-vivo calibration 274, 276
 - light intensity calibration 274
 - monitoring 36
- SVR/SVRI 226
- system pulse 181
- systolic blood pressure, NBP, early 206
- T**
- tabular trends 313
- Tamb 212
- task window for ST map 174
- Tcereb 212
- tcGas 263
 - sensor temperature 264
 - transducer, calibrating 247
- tcGas site timer 264
- technical alarms messages 81
 - see INOPs 81
- telemetry alarms 124
 - suspending at bedside 124
- temperature 211
 - accessories 435
 - alarm settings 211
 - connecting probe to monitor 211
 - difference, calculating 212
 - dual Temp measurement 212
 - extended label set 212
 - first 212
 - label 44
 - making a measurement 211
 - probe, disposable 211
 - probe, selecting 211
 - second 212
 - tcGas sensor 264
- temperature probe 211
- testing alarms 73
- time, setting 47
- timers 395, 396, 397
 - counting direction 396
 - displaying on main screen 397
 - notification 397
 - selecting label 396
 - viewing 311
- Tinj Probe Type 230
- titration table (drug calculator) 385
- tone configuration, alarm 62
- tone mod (SpO2) 201
- tone modulation 201
- touchscreen 30
 - disabling 30
- TP numeric (BIS) 290
 - on/off 290
- trackball 30
- trackball, using 30
- trademarks 445
- transcutaneous gas measurements 263
- transducer 215, 247, 265
 - CO2, accuracy 247
 - CO2, calibrating 247
 - pressure, zeroing 215
 - tcGas, calibrating 265
- transferring centrally-monitored patients 113, 114
 - using IIT 114

transferring patients with MMS 115
trend time 320
 global 320
trend view 173
 ST map 172
trending interval 175
 ST map 172
trends 311
 automatic unit conversion 328
 automatic value substitution 328
 database configuration 319
 resolution 316
 screen trends 320
 setting parameter scales 317
 setup 230
 viewing 311
trends pop-up keys 312
trends priority list 316
 ST map 172
trigger conditions 337
 events 337
triggers 336
 for events 336
troubleshooting 417
 CO2 247, 248, 249
trunk cables 419, 422
Tt ymp 212
Tvesic 212

U

unfiltered ECG signal 137
upgrading 284
 effect on EEG configuration 284

V

V electrode placement (ECG) 142
venous puncture 210
ventilation calculations 325
viewing arrhythmia waves 156
viewing trends 311
visible waves report 372
visitor screen 39
visual latching (arrhythmia alarms) 161
vital signs 312
 recording 319
 report 319
vital signs report 319
volume 62
 alarm 62
volume-flow loops 399
VueLink 387
 alarm messages 389
 device driver conflicts 390

language conflicts 390
module 387
module options 387
module setup 388
visible waves and numerics 387

W

wave 42, 217, 250, 260
 changing speed 42
 scale (CO2) 250, 260
 scale (pressure) 217
 size (CO2) 250, 260
 size (pressure) 217
wave channel speed 42
wave group speed 42
wave scale (EEG) 290
 changing 37
wave size 136
 Resp 186
wave size (ECG) 136
wave speed 42
 eeg speed 42
 wave speed 42
 global speed 42
 respiratory speed 42
wave speed (EEG) 283
wave speed (Resp) 188
wedge 222
 balloon inflation 222
 editing 223
 pulmonary artery 222
 reference waves 222
wide alarms limits 70

Z

zero 215
 effect on pressure alarms 215
zeroing 215
 pressure transducer 215



Part Number 453564443141
Published in Germany 11/2013



PHILIPS