**COMPLIANCE WORLDWIDE INC.
TEST REPORT 278-11R1**

In Accordance with the Requirements of
**FCC PART 15.247, SUBPART C
INDUSTRY CANADA RSS 210, ISSUE 8**

Low Power License-Exempt Radio Communication Devices
Intentional Radiators

Issued to

**Philips Medical Systems
3000 Minuteman Drive
Andover, MA 01810
978-659-2800**

for the

**Philips Telemetry System
MX40 Patient Worn Monitor
2.4 GHz CTS Radio**

**FCC ID: PQC-MX40SH24
IC: 3549B-MX40SH24**

Original Report Issued on August 2, 2011

Tested by

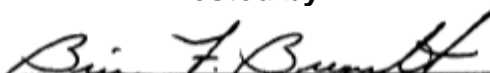

Brian F. Breault

Reviewed by



Larry K. Stillings

This test report shall not be reproduced, except in full, without written permission from Compliance Worldwide, Inc.

Table of Contents

1. Scope	3
2 .Product Details.....	3
2.1 Manufacturer	3
2.3 Serial Number.....	3
2.4 Description.....	3
2.5 Power Source	3
2.6 EMC Modifications.....	3
3. Product Configuration	4
3.1 Operational Characteristics & Software	4
3.2 EUT Hardware.....	4
3.3 EUT Hardware/Software/Firmware Revision Level.....	4
3.4 EUT Cables/Transducers	4
3.5 Support Equipment.....	4
3.6 Support Equipment Cables/Transducers	5
3.7 Miscellaneous.....	5
3.8 Block Diagram	5
4. Measurements Parameters	6
4.1 Measurement Equipment Used to Perform Test.....	6
4.2 Measurement & Equipment Setup	6
4.3 Measurement Procedure.....	6
4.4 Measurement Uncertainty	7
5. Choice of Equipment for Test Suits.....	7
5.1 Choice of Model.....	7
5.2 Presentation	7
5.3 Choice of Operating Frequencies.....	7
6. Measurement Summary.....	8
7. Measurement Data.....	9
7.1 Antenna Requirement	9
7.2 Minimum 6 dB Bandwidth.....	9
7.3 99% Bandwidth.....	11
7.4 Maximum Peak Conducted Output Power	14
7.5 Operation with directional antenna gains greater than 6 dBi	17
7.6 Transmitter Spurious Radiated Emissions	19
7.7 Receiver Spurious Radiated Emissions	20
7.8 Band Edge Measurements	23
7.9 Power Spectral Density	27
7.10 Public Exposure to Radio Frequency Energy Levels.....	29
8. Test Setup Photographs	31
9. Test Site Description.....	34

1. Scope

This test report certifies that the Philips Medical Telemetry System MX40 2.4 GHz Patient Worn Monitor (PWM) CTS Radio, as tested, meets the FCC Part 15, Subpart C and Industry Canada RSS 210, Issue 8 requirements. The scope of this test report is limited to the test sample provided by the client, only in as much as that sample represents other production units. If any significant changes are made to the unit, the changes shall be evaluated and a retest may be required. Revision R1 added lower restricted band measurement plot to Section 7.8: Band Edge Measurements.

2. Product Details

2.1. Manufacturer: Philips Medical Systems

2.2. Model Number: IntelliVue MX40 2.4 GHz

2.3. Serial Number: US11400397

2.4. Description: The Patient Worn Monitor is a body worn patient monitor for ECG and SpO2 measurements. The device has a touch screen display which can display patient waveforms and/or numeric values locally or transmitted via several possible radio links to the hospital wireless network, a wireless bedside monitor, or to a CTS network for display on the IntelliVue Information Center. The device is capable of transmitting in the 2.4GHz (ISM bands), 5.6GHz (ISM bands) and/or the WMTS bands, 1395 MHz to 1400 MHz and 1427 MHz to 1432 MHz. The PWM contains an 802.11 a/b/g WLAN radio to communicate with a WLAN, an 802.15.4 SRR radio to communicate with a SRR equipped bedside monitor, or an optional 1.4 GHz or 2.4 GHz CTS radio to communicate with a Philips CTS network. Performance evaluation during immunity testing shall be done on the PWM display, the WLAN display, the IntelliVue Information Center display and the MP5 bedside monitor. The PWM will be configured with a 2.4 GHz CTS radio for this test plan.

2.5. Power Source: DC 3 volts – Three 1.5 VDC Alkaline AA Batteries (Regulated)

2.6. EMC Modifications: None

3. Product Configuration

3.1. Operational Characteristics & Software

The MX40 Patient Worn Monitor (PWM) will be operating in normal mode transmitting patient ECG and SpO2 data to the ITS4852A Wireless Access Point and through the M3185A IntelliVue Information Network for display on the IntelliVue Information Center, i.e. Central Station. The PWM will need to be put into “TELEMETRY” mode during all testing to allow onboard display to be viewed. To do this, with the PWM running, press the middle “SMART KEY” button on the PWM front panel. When the “SMART KEY” menu comes up, press the “Mode: Telemetry” button. The state should change to “Mode: Monitor”.

3. Product Configuration

3.1. Operational Characteristics & Software (continued)

Simulator Setup:

Connect the MX40 PWM leadset to the Lionheart 2 according to color coding. Power on the Lionheart 2 simulator and press the “Execute” button. The Lionheart 2 comes up in ECG simulation at 80 bpm by default- it is also menu item “34”. Connect the CTS network infrastructure and Philips Information Center hardware together as shown:

Central Station Setup:

Power on the CTS network infrastructure components. The Central station & Infrastructure will be pre-configured by R&D, such that on Power-up of the system the desired operation mode will be active displaying 3 ECG waveforms and an SpO2 waveform. Power on the M3150A PIC components. The Philips Information Center Central station software should load automatically within about 5 minutes. 3 patient windows should now have an ECG trace with a cardiotech reading of 80 bpm. SpO2 should also be displayed at 93% ±2%.

3.2. EUT Hardware

Blk Diag #	Manufactr	Model/Part # / Options	Serial Number	Input Voltage	Frq (Hz)	Description/Function
1	Philips	865351/MX40	US11400397	3 V	DC	Patient Worn Monitor w/2.4 GHz CTS radio, PP3 build units

3.3. EUT Hardware/Software/Firmware Revision Level

EUT Model#	PCA#	Description	HW	SW	FW
MX40		2.4 GHz CTS radio	Rev. 02	A.00.28	

3.4. EUT Cables/Transducers

Blk Diag Ltr	Manufacturer	Model/Part #	Length (m)	Shield Y/N	Description/Function
A	Philips	989803171871	0.8	Y	SpO2 connector/ECG leadset- 6 leads
B	Philips	M1191A	2	N	SpO2 patient transducer

3.5. Support Equipment

Diag Blk #	Manufacturer	Model/Part # Options	Serial Number	Input Voltage	Input Frq.	Description/Function
2	Philips	ITS4852A	US80325379	48	DC	2.4 GHz Access Point
4	PowerDSine	ITS4845A (6506)	P06451223000004A00	100-240	50-60	Power-over-Ethernet hub
5	Cisco	WS-C2950C-24	FOC1034Z2FU	100-240	50-60	LAN switch
6	Philips	M3154B	2UA610JXKJ	100-240	50-60	InbteilliVue Information Center
7	Philips	M3154B	2UA610JXJK	100-240	50-60	InbteilliVue Information Center
8	Philips	ITS3171A	756005AG-35200536	100-240	50-60	Access Point Controller
9	Linksys	WRT320N	CUH017J726025	12	DC	WLAN router
10	Philips	865024/M8105A	DE74808392	100-240	50-60	MP5 Patient Bedside Monitor
11	Philips	LE1708	14AP1727A00	100-240	50-60	Display
12	Philips	190P6EB/27	BZ000534113115	100-240	50-60	Display

Note: Blk Diag #'s 2, 4, 5, 6 and 11 were configured for this test.

3. Product Configuration (continued)

3.6. Support Equipment Cables/Transducers

Blk Diag Ltr	Manufacturer	Model/Part #	Length (m)	Shield Y/N	Description/Function
C	NA	NA	Various	N	Cat 5 LAN cables

3.7. Miscellaneous

Manufacturer	Model/Part #	Description/Function
Duracell	NA	AA batteries
Philips	453564128871	Li-ion rechargeable batteries

3.8. Block Diagram

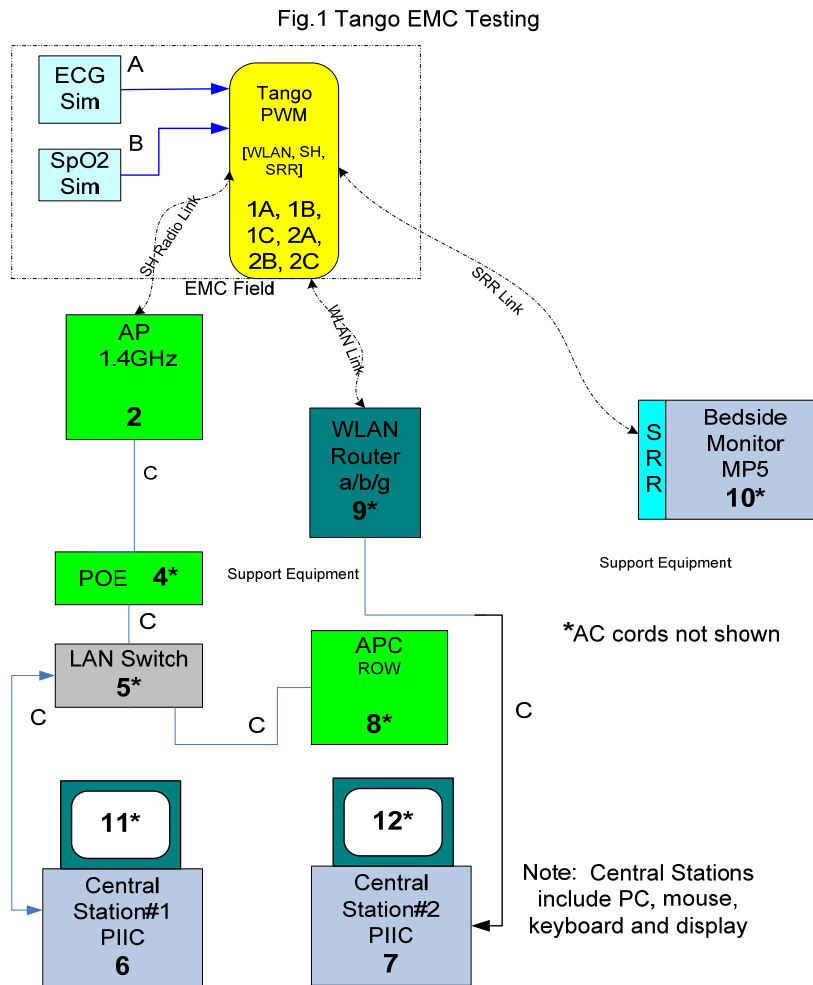

Note: Blk Diag #'s 2, 4, 5, 6 and 11 were configured as support equipment for this test.

4. Measurements Parameters

4.1. Measurement Equipment Used to Perform Tests

Device	Manufacturer	Model No.	Serial No.	Cal Due
Spectrum Analyzer	Agilent	E4407B	MY45104493	12/22/2012
Microwave Preamp	Hewlett Packard	8449B	3008A01323	12/1/2012
Spectrum Analyzer	Agilent	E7405A	MY45115430	10/22/2011
Bilog Antenna	Com-Power	AC-220	25509	8/30/2011
Horn Antenna	Electro-Metrics	EM-6961	6337	10/19/2012
Horn Antenna	ComPower	AH-118	10078	7/23/2011
Horn Antenna	ComPower	AH-840	03075	7/20/2012
DMM / Temperature	Fluke	187	79690058	11/29/2011
RF Signal Generator	Hewlett Packard	8648C	3642U01557	7/16/2011
2.4 GHz BP Filter	Micro-Tronics	BRM50702	14	8/11/2011
Digital Barometer	Control Company	4195	ID236	11/9/2011
Thermal Chamber	Associated Testing Labs	SLHU-1-CRLC	N/A	Not Required

4.2. Measurement & Equipment Setup

Test Dates: June 27, 2011 to July 1, 2011
 Test Engineer: Brian Breault
 Normal Site Temperature (15 - 35°C): 21.7
 Relative Humidity (20 -75%RH): 33%
 Frequency Range: 30 MHz to 15 GHz
 Measurement Distance: 3 Meters
 EMI Receiver IF Bandwidth: 120 kHz - 30 MHz to 1 GHz
 1 MHz - Above 1 GHz
 EMI Receiver Avg Bandwidth: 300 kHz - 30 MHz to 1 GHz
 3 MHz - Above 1 GHz
 Detector Function: Peak, QP - 30 MHz to 1 GHz
 Peak, Avg - Above 1 GHz
 Unless otherwise specified.

4.3. Measurement Procedure

Test measurements were made in accordance FCC Part 15.247, IC RSS-210 Annex II: Operation within the bands 902 - 928 MHz, 2400 - 2483.5 MHz, 5725 - 5875 MHz, and 24.0 - 24.25 GHz.

The test methods used to generate the data in this test report is in accordance with ANSI C63.4: 2003, American National Standard for Methods of Measurement of Radio-Noise Emissions from Low-Voltage Electrical and Electronic Equipment in the Range of 9 kHz to 40 GHz

In accordance with ANSI C63.4-2003, section 13.4.1, c), the device under test was rotated through three orthogonal axes to determine which attitude produced the highest emission relative to the limit. The attitude that produced the highest emission relative to the limit was used for all radiated emission measurements.

4. Measurements Parameters

4.4. Measurement Uncertainty

The following uncertainties are expressed for an expansion/coverage factor of K=2.

RF Frequency	$\pm 1 \times 10^{-8}$
Radiated Emission of Transmitter	± 4.55 dB
Radiated Emission of Receiver	± 4.55 dB
Temperature	$\pm 0.91^{\circ}$ C
Humidity	$\pm 5\%$

5. Choice of Equipment for Test Suits

5.1 Choice of Model

This test report is based on the test samples supplied by the manufacturer and are reported by the manufacturer to be equivalent to the production units.

5.2 Presentation

This test sample was tested complete with all required ancillary equipment. Refer to Section 3 of this report for product equipment configuration.

5.3 Choice of Operating Frequencies

The MX40 2.4 GHz Patient Worn Monitor CTS operates on a total of 48 channels, from channel 0 to channel 47.

In accordance with ANSI C63.4-2009, section 13.2.1, the choice of operating frequencies selected for the testing outlined in this report was based on the lowest, middle and highest operating frequencies. The frequencies selected were 2401.060 MHz (Channel 0), 2442.320 MHz (Channel 24) and 2482.252 MHz (Channel 47).

6. Measurement Summary

Test Requirement	FCC Rule Reference	IC Rule Reference	Test Report Section	Result
Antenna Requirement	15.203	RSS-GEN 7.1.2	7.1	Compliant
Minimum 6 dB Bandwidth	(a) (2)	RSS-210 A8.2	7.2	Compliant
99% Bandwidth	N/A	RSS-GEN 4.6.1	7.3	Compliant
Maximum Peak Conducted Output Power	(b) (1)	RSS-210 A8.4 (4)	7.4	Compliant
Operation with directional antenna gains greater than 6 dBi	(b) (4)	RSS-GEN 7.1.2	7.5	Compliant
Spurious Radiated Emissions	15.247 (d)	RSS-GEN 4.9	7.6	Compliant
Spurious Radiated Emissions (> GHz) - Harmonic Measurements	15.247 (d)	RSS-210 A8.9	7.6	Compliant
Receiver Spurious Radiated Emissions	15.247 (d)	RSS-GEN 4.10	7.7	Compliant
Lower and Upper Band Edge	15.247 (d)	RSS-210 A8.5	7.8	Compliant
Power Spectral Density	15.247(e)		7.9	Compliant
Conducted Emissions	FCC Part 15	RSS-GEN	N/A	Compliant
Public Exposure to Radio Frequency Energy Levels	1.1307 (b) (1)	RSS-GEN 5.5 RSS-102	7.10	Compliant

7. Measurement Data

7.1. Antenna Requirement (15.203, RSS GEN 7.1.2)

Requirement: An intentional radiator shall be designed to ensure that no antenna other than that furnished by the responsible party shall be used with the device. The use of a permanently attached antenna or of an antenna that uses a unique coupling to the intentional radiator shall be considered sufficient to comply with the provisions of this Section.

Status: The CTS radio antenna is internal to the unit and not user accessible.

7.2. Minimum 6 dB Bandwidth (15.247 (a) (2), RSS 210 A8.2(a))

Requirement: Systems using digital modulation techniques may operate in the 902 - 928 MHz, 2400 - 2483.5 MHz, and 5725 - 5850 MHz bands. The minimum 6 dB bandwidth shall be at least 500 kHz.

Resolution Bandwidth : 100 kHz

Video Bandwidth : 300 kHz

Measurement Results

Channel	Frequency (MHz)	6 dB Bandwidth (kHz)	Minimum 6 dB Bandwidth (kHz)	Result
Low	2401.060	950	>500	Compliant
Middle	2442.320	950	>500	Compliant
High	2482.252	960	>500	Compliant

7. Measurement Data

7.2. Minimum 6 dB Bandwidth (15.247 (a) (2)) (continued)

6.2.1. Low Channel – 0

13:28:28 JUN 30, 2011 6 DB BANDWIDTH
278-11 PHILIPS 2.4GHZ SH (CTS) CH0
MARKER Δ ACTV DET: PEAK
950 kHz MEAS DET: PEAK AVG
.02 dB MKRΔ 950 kHz
.02 dB

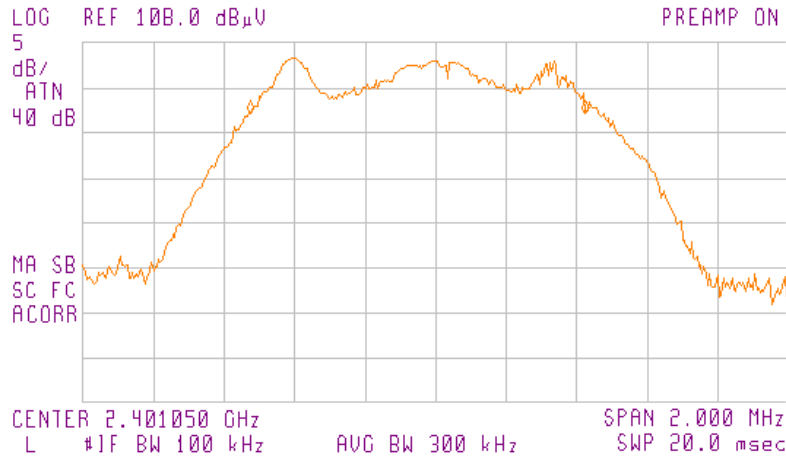

6.2.2. Mid Channel - 24

12:32:57 JUN 30, 2011 6 DB BANDWIDTH
278-11 PHILIPS 2.4GHZ SH (CTS) CH24
MARKER Δ ACTV DET: PEAK
950 kHz MEAS DET: PEAK AVG
-.24 dB MKRΔ 950 kHz
-.24 dB

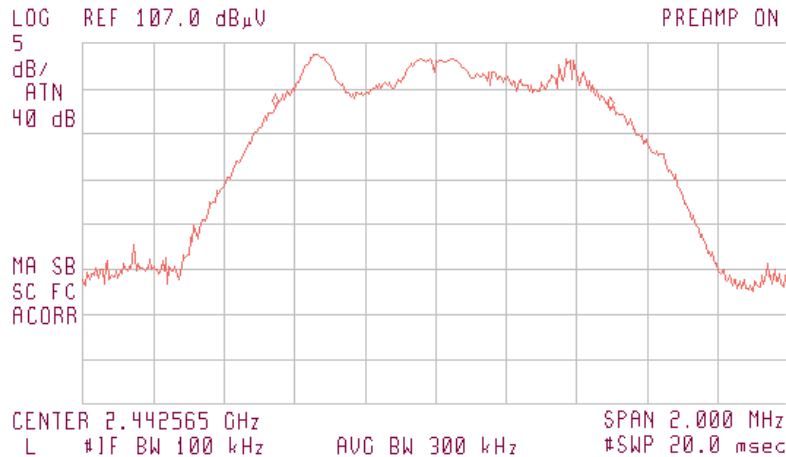

7. Measurement Data (continued)

7.2. Minimum 6 dB Bandwidth (15.247 (a) (2)) (continued)

6.2.3. High Channel - 47

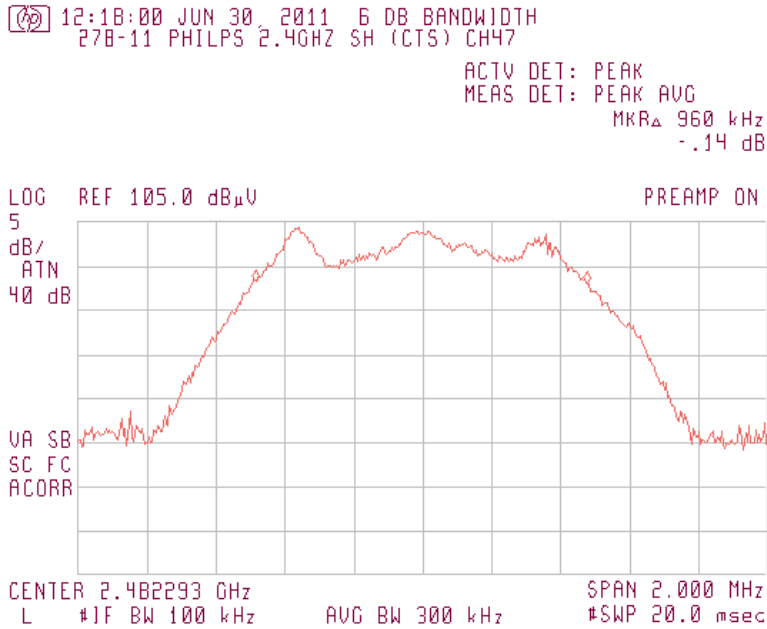

7.3. 99% Bandwidth (RSS 210)

Requirement: For devices operating above 900 MHz, the 99% bandwidth shall be no wider than 0.5% of the center frequency.

The transmitter shall be operated at its maximum carrier power measured under normal test conditions. The span of the analyzer shall be set to capture all products of the modulation process, including the emission skirts. The resolution bandwidth shall be set to as close to 1% of the selected span as is possible without being below 1%. The video bandwidth shall be set to 3 times the resolution bandwidth.

Resolution Bandwidth : 100 kHz
Video Bandwidth : 300 kHz

Measurement Results

Channel	Channel Frequency (MHz)	99% Power Bandwidth (MHz)	Acceptable Bandwidth (MHz)	Result
Low	2401.060	1.280	12.005	Compliant
Middle	2442.320	1.275	12.212	Compliant
High	2482.252	1.290	12.411	Compliant

7. Measurement Data (continued)

7.3. 99% Bandwidth (RSS 210) (continued)

7.3.1. Low Channel – 0

13:29:08 JUN 30, 2011 99% POWER BANDWIDTH
278-11 PHILIPS 2.4GHZ SH (CTS) CH0
MARKER Δ ACTV DET: PEAK
1.280 MHz MEAS DET: PEAK AVG
1.17 dB MKRΔ 1.280 MHz
1.17 dB

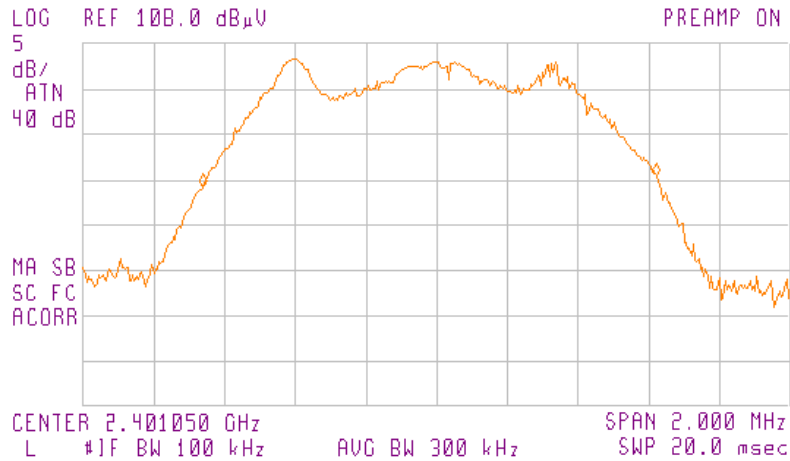

7.3.2. Mid Channel - 24

12:31:36 JUN 30, 2011 99% POWER BANDWIDTH
278-11 PHILIPS 2.4GHZ SH (CTS) CH24
MARKER Δ ACTV DET: PEAK
1.275 MHz MEAS DET: PEAK AVG
1.39 dB MKRΔ 1.275 MHz
1.39 dB

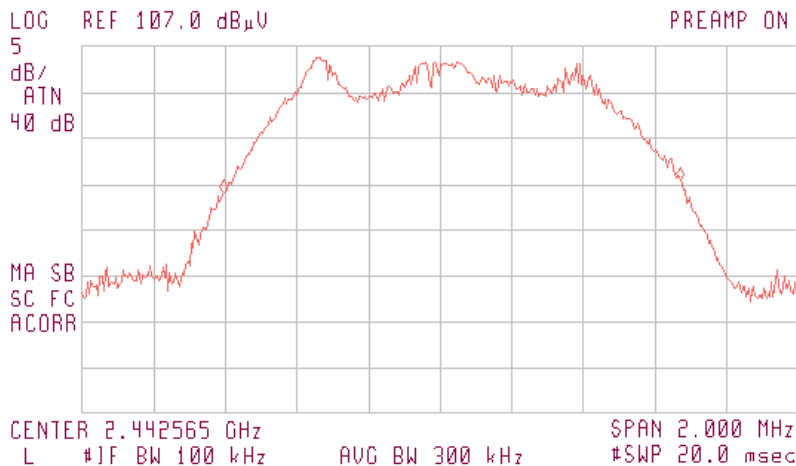

7. Measurement Data (continued)

7.3. 99% Bandwidth (IC RSS 210) (cont.)

7.3.3. High Channel - 47

12:22:46 JUN 30 2011 99% POWER BANDWIDTH
278-11 PHILIPS 2.4GHZ SH (CTS) CH47
MARKER Δ ACTV DET: PEAK
1.290 MHz MEAS DET: PEAK AVG
.62 dB MKR Δ 1.290 MHz
.62 dB

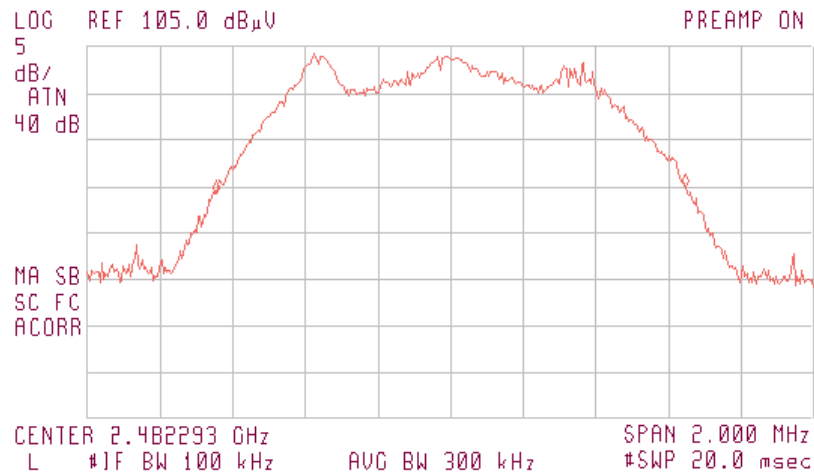

7. Measurement Data (continued)

7.4. Maximum Peak Conducted Output Power (15.247 (b) (1))

Requirement: The maximum peak conducted output power of the intentional radiator shall not exceed the following: For systems using digital modulation in the 902–928 MHz, 2400–2483.5 MHz, and 5725–5850 MHz bands: 1 Watt.

Test Notes: The MX40 Short Range Radio Antenna is not removable; therefore the output power was determined from the measured field strength using the following equation:

$$P = \frac{(E \times d)^2}{(30 \times G)}$$

- P = the power in Watts (power has been converted to milliwatts in the table).
- E = the measured maximum field in V/m.
- G = the numeric gain of the transmitting antenna over an isotropic radiator.
- d = the distance in meters of the field strength measurement.

Resolution Bandwidth : 1 MHz
 Video Bandwidth : 3 MHz

Measurement Results

Channel	Frequency	Peak Field Strength	Distance	Antenna Gain ¹	Output Power	Output Power Limit	Result
	(MHz)	(dBµV/m)	(m)	(dBi)	(mW)	(mW)	
Low	2401.060	107.6	3.0	-3.0	34.44	1000	Compliant
Middle	2442.320	107.2	3.0	-3.0	31.41	1000	Compliant
High	2482.252	105.9	3.0	-3.0	23.29	1000	Compliant

7. Measurement Data (continued)

7.4. Maximum Peak Conducted Output Power (15.247 (b) (1)) (continued)

7.4.1. Low Channel - 0

13:05:36 JUN 30 2011 PEAK & AVERAGE POWER
278-11 PHILIPS 2.4GHZ SH (CTS) CH0

MARKER
2.401013 GHz
106.61 dBμV

FREQ 2.401 GHz
PEAK 107.6 dBμV
QP NOT SELECTED
AVG 76.2 dBμV

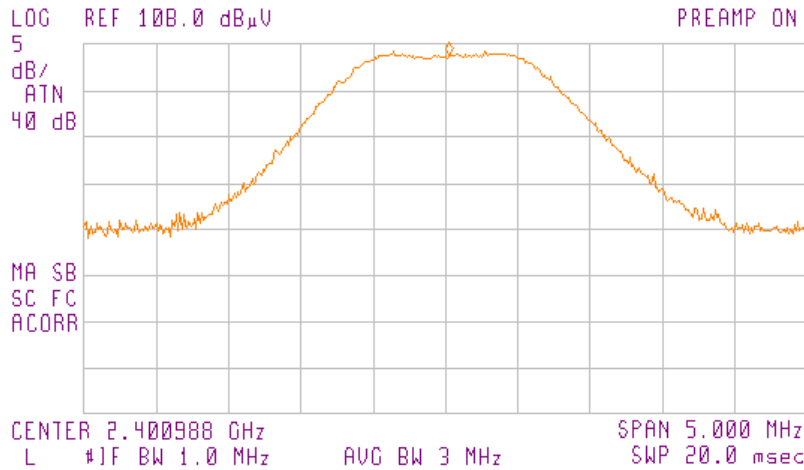

7.4.2. Middle Channel - 24

12:28:12 JUN 30 2011 PEAK & AVERAGE POWER
278-11 PHILIPS 2.4GHZ SH (CTS) CH24

FREQ 2.442 GHz
PEAK 107.2 dBμV
QP NOT SELECTED
AVG 75.8 dBμV

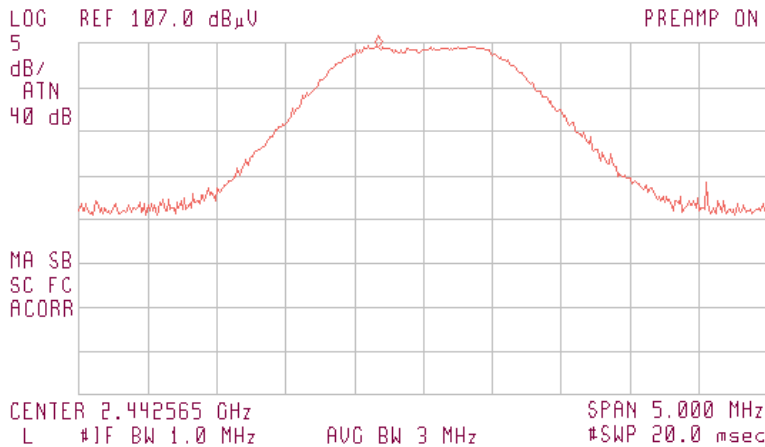

7. Measurement Data (continued)

7.4. Maximum Peak Conducted Output Power (15.247 (b) (1))

7.4.3. High Channel - 47

11:22:23 JUN 30, 2011 PEAK & AVERAGE POWER
278-11 PHILIPS 2.4GHZ SH (CTS) CH47

FREQ 2.483 GHz
PEAK 105.9 dBμV
QP NOT SELECTED
AVG 75.6 dBμV

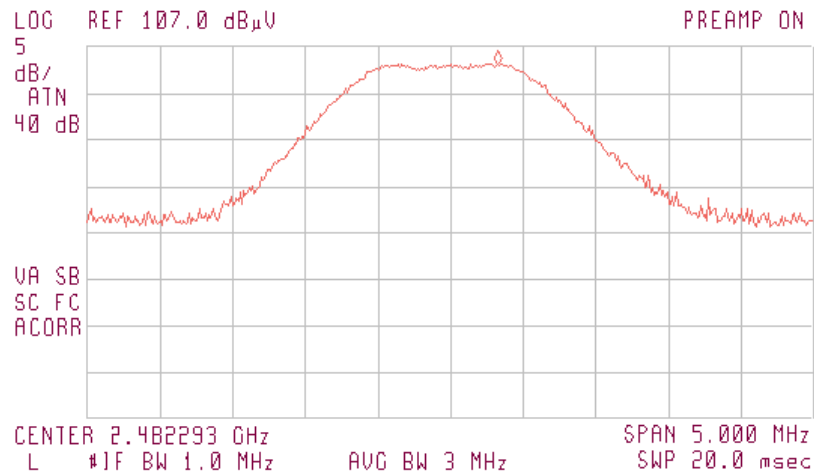

7. Measurement Data (continued)

7.5. Operation with directional antenna gains greater than 6 dBi (15.247 (b)(4))

Requirement: If transmitting antennas of directional gain greater than 6 dBi are used, the conducted output power from the intentional radiator shall be reduced below the stated values in paragraphs (b)(1), (b)(2), and (b)(3) of FCC Part 15.247, as appropriate, by the amount in dB that the directional gain of the antenna exceeds 6 dBi.

DUT Status: **The MX40 2.4 GHz CTS Radio utilizes an antenna with -3.0 dBi antenna gain value and therefore is not affected by this clause.**

7.6. Transmitter Spurious Radiated Emissions (30 MHz to 40 GHz)

7.6.1. Regulatory Limit: FCC, Part 209, Quasi-Peak

Frequency Range (MHz)	Distance (Meters)	Limit (dBµV/m)
30 to 88	3	40.0
88 to 216	3	43.5
216 to 960	3	46.0
>960	3	54.0

7.6.2. Measurement & Equipment Setup

Test Date: 7/1/2011
 Test Engineer: Ben Dovidio
 Site Temperature (°C): 21.3
 Relative Humidity (%RH): 31
 Frequency Range: 30 MHz to 40 GHz
 Measurement Distance: 3 Meters
 EMI Receiver IF Bandwidth: 120 kHz (30 MHz – 1 GHz)
 1 MHz (>1GHz)
 EMI Receiver Avg Bandwidth: 300 kHz (30 MHz – 1 GHz)
 3 MHz (>1GHz)
 Detector Functions: Peak, Quasi-Peak, Average
 Antenna Height: 1 to 4 meters

7.6.3. Test Procedure

Test measurements were made in accordance with ANSI C63.4-2003, Standard Methods of Measurement of Radio Noise Emissions from Low-Voltage Electrical and Electronics Equipment in the Range of 9 kHz to 40 GHz.

7. Measurement Data (continued)

7.6. Transmitter Spurious Radiated Emissions (30 MHz to 40 GHz)

7.6.4. Spurious Radiated Emissions (30 MHz – 1 GHz) Test Results

7.6.4.1. Measurement Results – Horizontal Polarity

14:04:50 JUL 01, 2011
 Chamber EN55022, Class B, Radiated Emissions Prescan
 ACTV DET: PEAK
 MEAS DET: PEAK
 MKR 264.1 MHz
 31.82 dB μ V

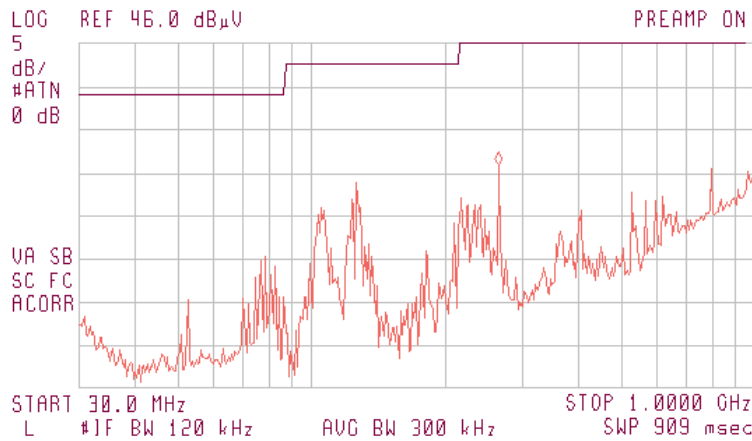

7.6.4.2. Measurement Results – Vertical Polarity

14:11:15 JUL 01, 2011
 Chamber EN55022, Class B, Radiated Emissions Prescan
 ACTV DET: PEAK
 MEAS DET: PEAK
 MKR 1.0000 GHz
 29.76 dB μ V

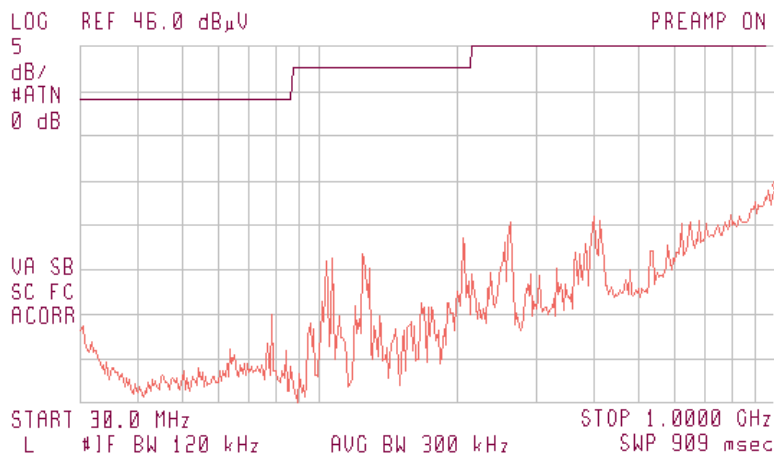

7. Measurement Data (continued)

7.6. Transmitter Spurious Radiated Emissions (30 MHz to 40 GHz)

7.6.5. Spurious Radiated Emissions (Above 1 GHz) Test Results

There were measurable no transmitter spurious emissions other than the emissions tabled in section 7.6.6.

7.6.6. Transmitter Spurious Radiated Emissions (Harmonic Meas.) Test Results

Freq. (MHz)	Field Strength (dBµV/m)		Limit (dBµV/m)		Margin (dBµV/m)		Antenna Polarity (H/V)	Result
	Peak	Average	Peak	Average	Peak	Average		
4802.120	48.39	32.04	74.00	54.00	-25.61	-21.96	H	Compliant
4885.240	57.46	35.28	74.00	54.00	-16.54	-18.72	V	Compliant
4964.504	58.72	34.06	74.00	54.00	-15.28	-19.94	H	Compliant
7203.180	49.77	36.84	74.00	54.00	-24.23	-17.16	H	Compliant
7327.860	51.27	38.26	74.00	54.00	-22.73	-15.74	V	Compliant
7446.756	50.55	38.20	74.00	54.00	-23.45	-15.80	V	Compliant
9604.240	52.18	39.23	74.00	54.00	-21.82	-14.77	H	Compliant
9770.480	52.37	40.39	74.00	54.00	-21.63	-13.61	H	Compliant
9929.008	54.43	42.01	74.00	54.00	-19.57	-11.99	H	Compliant
12005.300	55.51	42.49	74.00	54.00	-18.49	-11.51	H	Compliant
12213.100	55.07	42.40	74.00	54.00	-18.93	-11.60	V	Compliant
12411.260	56.10	43.90	74.00	54.00	-17.90	-10.10	H	Compliant
14406.360	61.16	48.48	74.00	54.00	-12.84	-5.52	H	Compliant
14655.720	61.08	48.81	74.00	54.00	-12.92	-5.19	H	Compliant
14893.512	61.16	48.33	74.00	54.00	-12.84	-5.67	H	Compliant
16807.420	60.64	47.91	74.00	54.00	-13.36	-6.09	H	Compliant
17098.340	61.79	49.62	74.00	54.00	-12.21	-4.38	H	Compliant
17375.764	56.83	44.16	74.00	54.00	-17.17	-9.84	V	Compliant
19208.480	55.02	41.99	74.00	54.00	-18.98	-12.01	H	Compliant
19540.960	54.61	43.59	74.00	54.00	-19.39	-10.41	H	Compliant
19858.016	54.14	41.55	74.00	54.00	-19.86	-12.45	V	Compliant
21609.540	54.69	42.44	74.00	54.00	-19.31	-11.56	H	Compliant
21983.580	55.95	43.76	74.00	54.00	-18.05	-10.24	H	Compliant
22340.268	55.46	43.04	74.00	54.00	-18.54	-10.96	H	Compliant
24010.600	56.36	43.92	74.00	54.00	-17.64	-10.08	H	Compliant
24426.200	59.60	48.73	74.00	54.00	-14.40	-5.27	H	Compliant
24822.520	60.60	47.35	74.00	54.00	-13.40	-6.65	V	Compliant

¹ All correction factors are stored in the spectrum analyzer and applied to this column entry.

7. Measurement Data (continued)

7.7. Receiver Spurious Emissions (RSS 213 6.8, RSS-Gen 4.10 & 7.2.3.1)

Requirement: RSS 213 6.8 - Receiver spurious emissions shall comply with the limits specified in RSS-Gen.

RSS-Gen 4.10 – Radiated emission measurements are to be performed using a calibrated open-area test site. As an alternative, the conducted measurement method may be used when the antenna is detachable. In such a case, the receiver spurious signal may be measured at the antenna port. The limits for this measurement were taken from section 7.2.3.1:

2 η W	30 MHz to 1 GHz
5 η W	above 1 GHz

Status: The device under test requires that at least one channel is configured to transmit. Channel 24 (midpoint channel) was enabled.

7.7.1. Receiver Spurious Emissions, 30 MHz to 1 GHz Horizontal Polarity

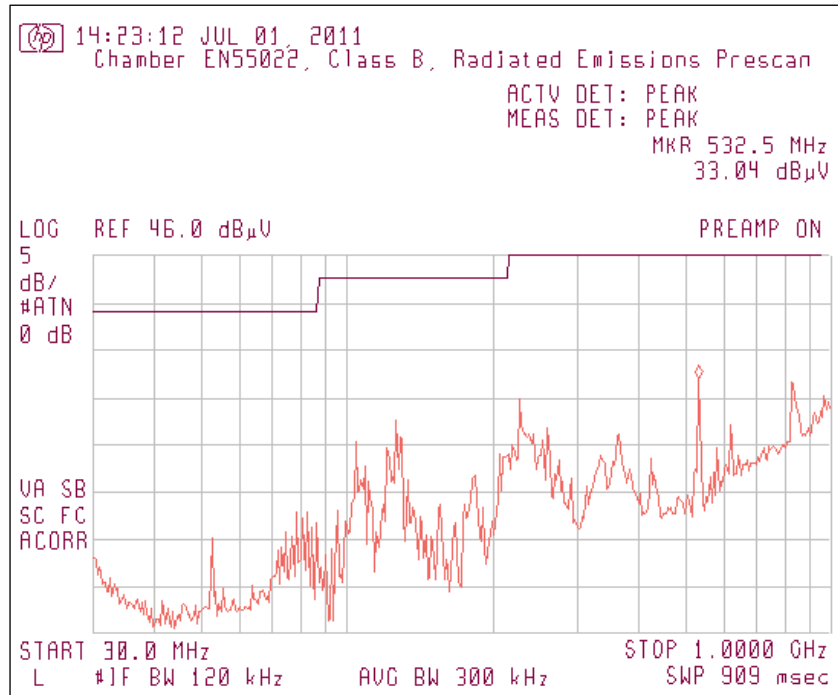

7. Measurement Data (continued)

7.7. Receiver Spurious Emissions (RSS 213 6.8, RSS-Gen 4.10 & 7.2.3.1)

7.7.2. Receiver Spurious Emissions, Above 1 GHz Horizontal Polarity

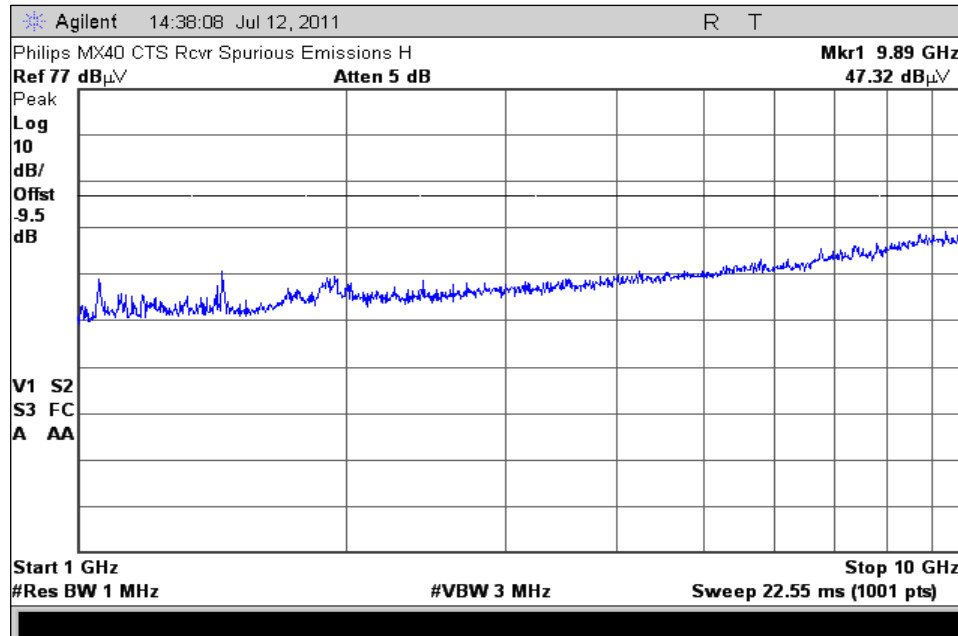

7.7.3. Receiver Spurious Emissions, 30 MHz to 1 GHz Vertical Polarity

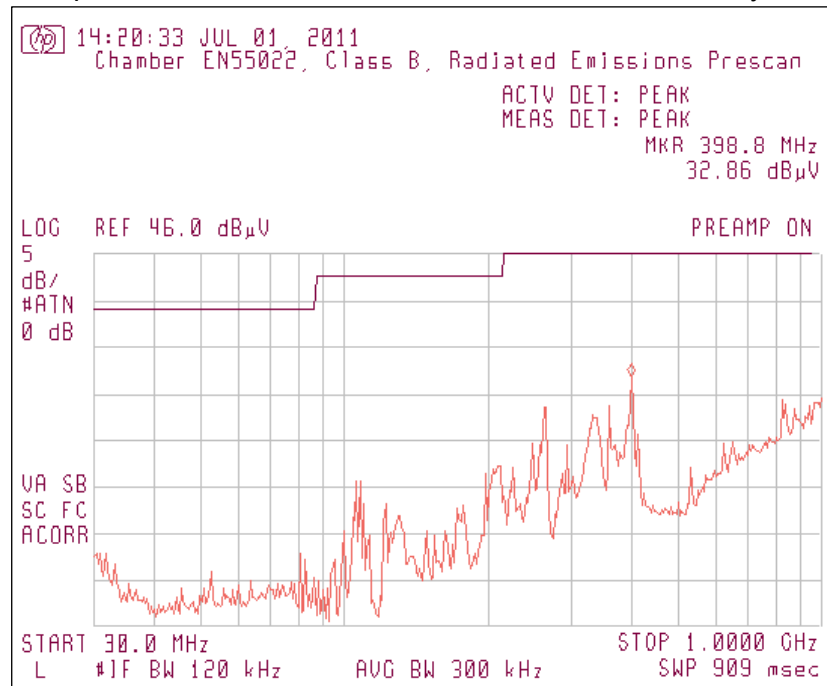

7. Measurement Data (continued)

7.7. Receiver Spurious Emissions (RSS 213 6.8, RSS-Gen 4.10 & 7.2.3.1) (continued)

7.7.4. Receiver Spurious Emissions, Above 1 GHz Vertical Polarity

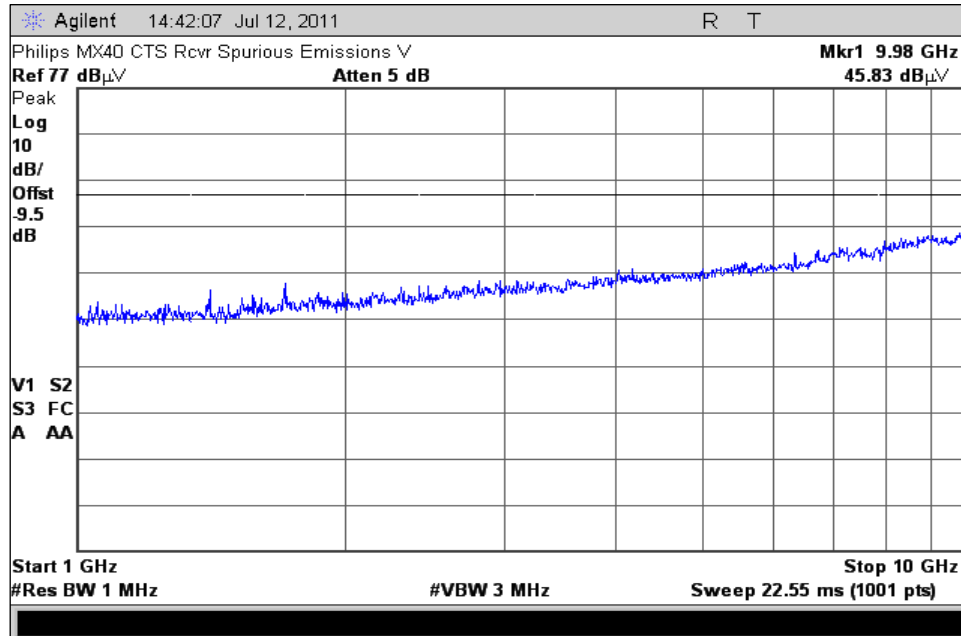

7. Measurement Data (continued)

7.8. Band Edge Measurements

Requirement: In any 100 kHz bandwidth outside the frequency band in which the spread spectrum or digitally modulated intentional radiator is operating, the radio frequency power that is produced by the intentional radiator shall be at least 20 dB below that in the 100 kHz bandwidth within the band that contains the highest level of the desired power, based on either an RF conducted or a radiated measurement, provided the transmitter demonstrates compliance with the peak conducted power limits. If the transmitter complies with the conducted power limits based on the use of RMS averaging over a time interval, as permitted under paragraph (b)(3) of this section, the attenuation required under this paragraph shall be 30 dB instead of 20 dB. Attenuation below the general limits specified in Section 15.209(a) is not required. In addition, radiated emissions which fall in the restricted bands, as defined in Section 15.205(a), must also comply with the radiated emission limits specified in Section 15.209(a) (see Section 15.205(c)).

Test Note: For the upper band edge measurement, the procedure detailed in the FCC Office of Engineering and Technology (FCC OET) Publication Number 913591 was used in determining the measurement results.

Measurement Results – Lower Band Edge

Lowest Channel (MHz)	Field Strength (dBµV/m)		Band Edge Frequency (MHz)	Field Strength (dBµV/m)		Limit	Margin (dB)	Result
	Peak	Average		Peak	Average			
2401.060	107.6	---	2400	85.4	---	>20 dB	-2.2	Compliant

Measurement Plot – Lower Band Edge

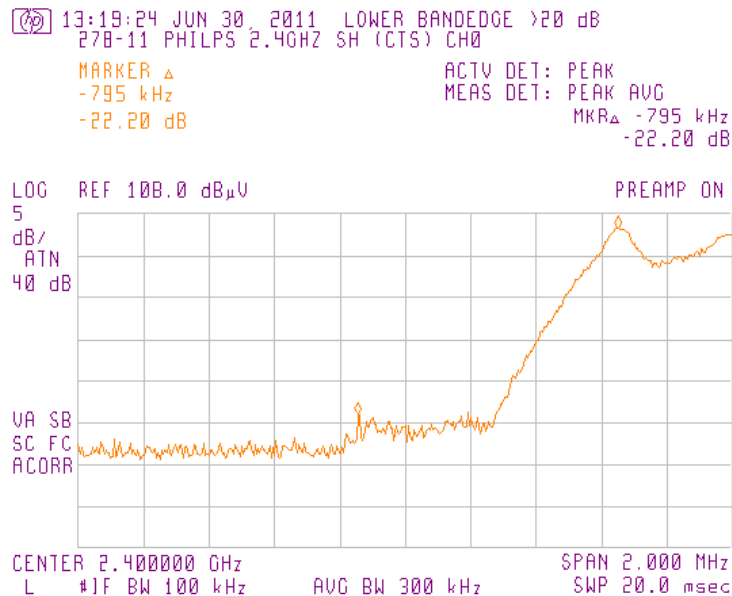

7. Measurement Data (continued)

7.8. Band Edge Measurements (continued)

Measurement Results – Upper Band Edge

FCC OET Publication Number KDB 913591 Calculator

Highest Channel Frequency (MHz)	Highest Channel Field Strength (dBµV/m)		Band Edge & W/C Out of Band Calculator		Corrected Band Edge & Worst Case Out of Band (dBµV/m)	
			Freq. (MHz)	30 kHz BW Offset (dB) ³		
	Peak ¹	Average ²				
2482.320	105.9	67.29	2483.500	38.18	67.72	29.11
			2483.532	37.93	67.97	29.36

- Notes: 1 – Peak value from plot in 7.8.1
 2 – Average value from plot in 7.8.2
 3 – Delta values from plot in 7.8.3
 Delta values are subtracted from peak & average values

Corrected Measurement Results (Delta values vs limits)

	Freq. (MHz)	Field Strength (dBµV/m)		Limit (dBµV/m)		Margin (dBµV/m)		Result
		Peak	Average	Peak	Average	Peak	Average	
Upper Band Edge	2483.5	67.72	29.11	74	54	-6.28	-24.89	Compliant
Worst Case Out of Band	2483.532	67.97	29.36	74	54	-6.03	-24.64	Compliant

7.8.1. Channel 47 Field Strength - Peak

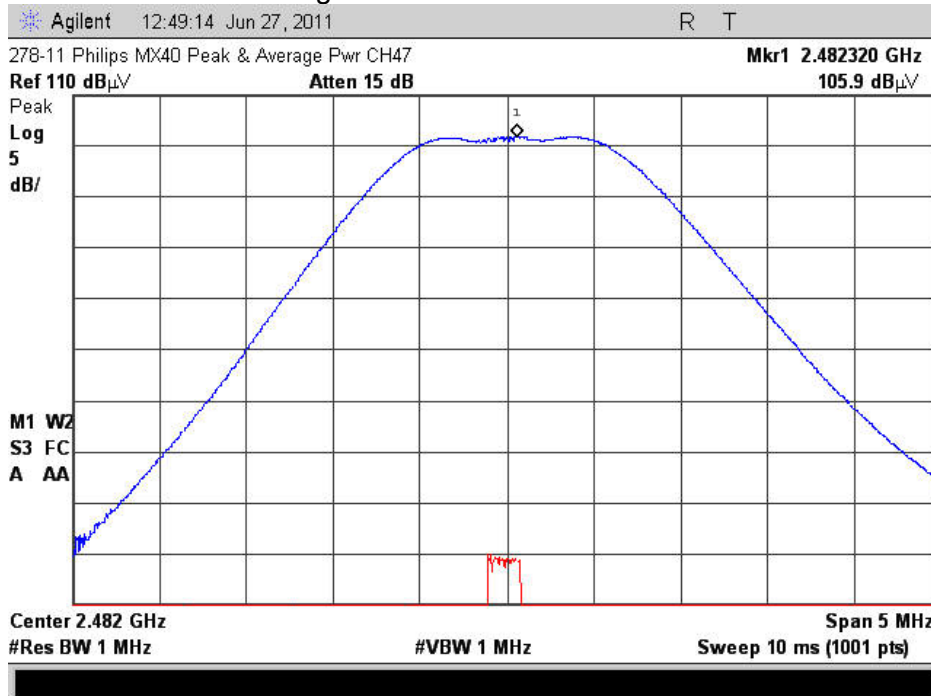

7. Measurement Data (continued)

7.8. Band Edge Measurements

7.8.2. Channel 47 Field Strength - Average

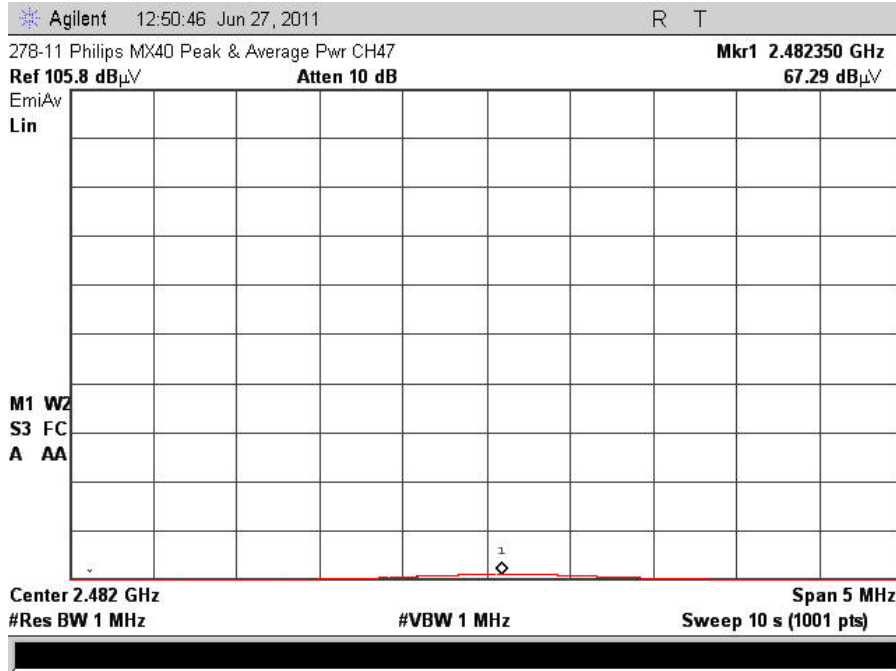

7.8.3. 30 kHz Amplitude Offset

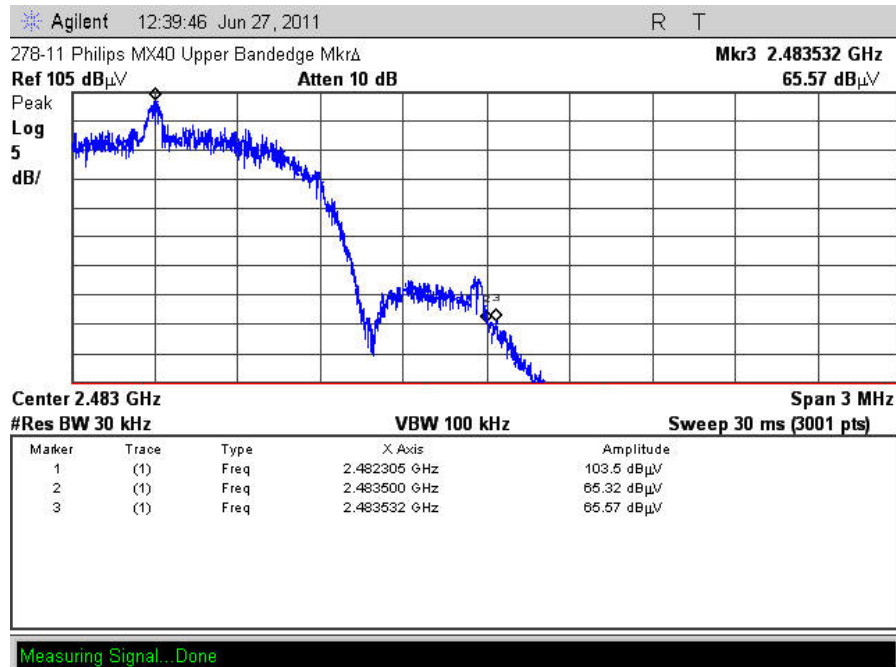

7. Measurement Data

7.8. Band Edge (15.247 (d), RSS-210 A8.5)

7.8.4. Lower Restricted Band (2310 MHz to 2390 MHz)

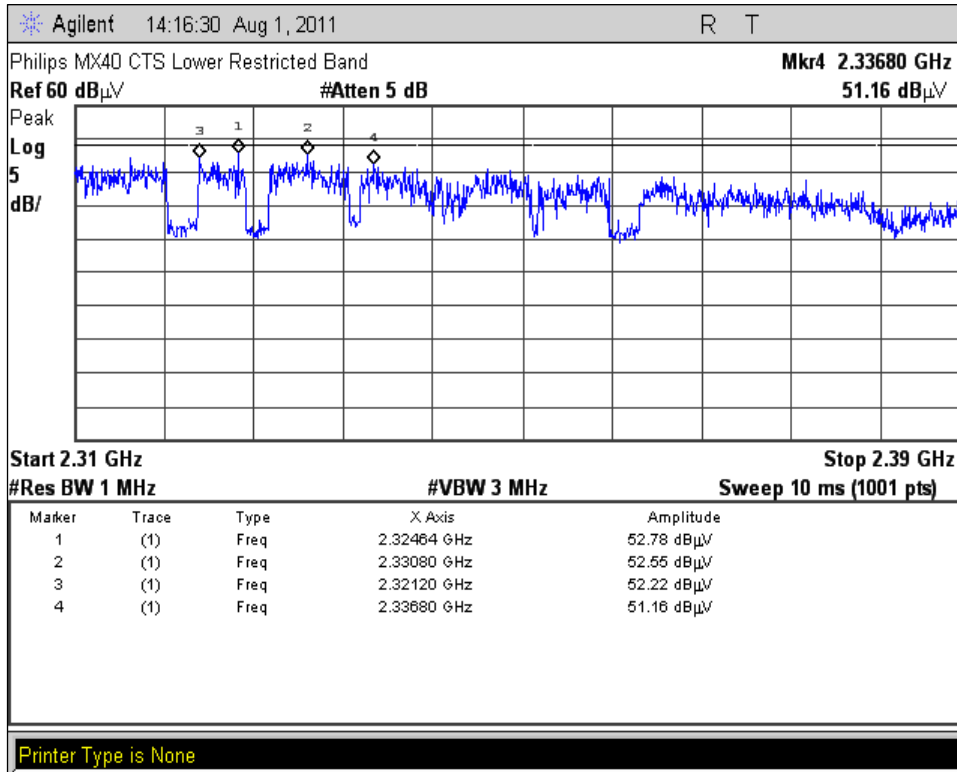

Freq. (MHz)	Field Strength (dBμV/m)		Limit (dBμV/m)		Margin (dBμV/m)	
	Peak	Average	Peak	Average	Peak	Average
2324.64	52.78	31.90	74.00	54.00	-21.22	-22.10
2330.80	52.55	32.93	74.00	54.00	-21.45	-21.07
2321.20	52.22	31.77	74.00	54.00	-21.78	-22.23
2336.80	51.16	33.44	74.00	54.00	-22.84	-20.56

7. Measurement Data (continued)

7.9. Power Spectral Density (15.247(e))

Requirement: For digitally modulated systems, the power spectral density conducted from the intentional radiator to the antenna shall not be greater than 8 dBm in any 3 kHz band during any time interval of continuous transmission. This power spectral density shall be determined in accordance with the provisions of paragraph (b) of this section. The same method of determining the conducted output power shall be used to determine the power spectral density.

Channel	Channel Frequency (GHz)	Measured Frequency (GHz)	PSD Value Radiated (dBμV/m)	Power Spectral Density (dBm)	Limit (dBm)	Result
Low	2401.060	2.4009690	92.75	-0.521	8	Compliant
Middle	2442.320	2.4426230	91.40	-0.829	8	Compliant
High	2482.252	2.4823165	92.26	0.031	8	Compliant

7.9.1. Power Spectral Density Measurement Plot, Low Channel – 0

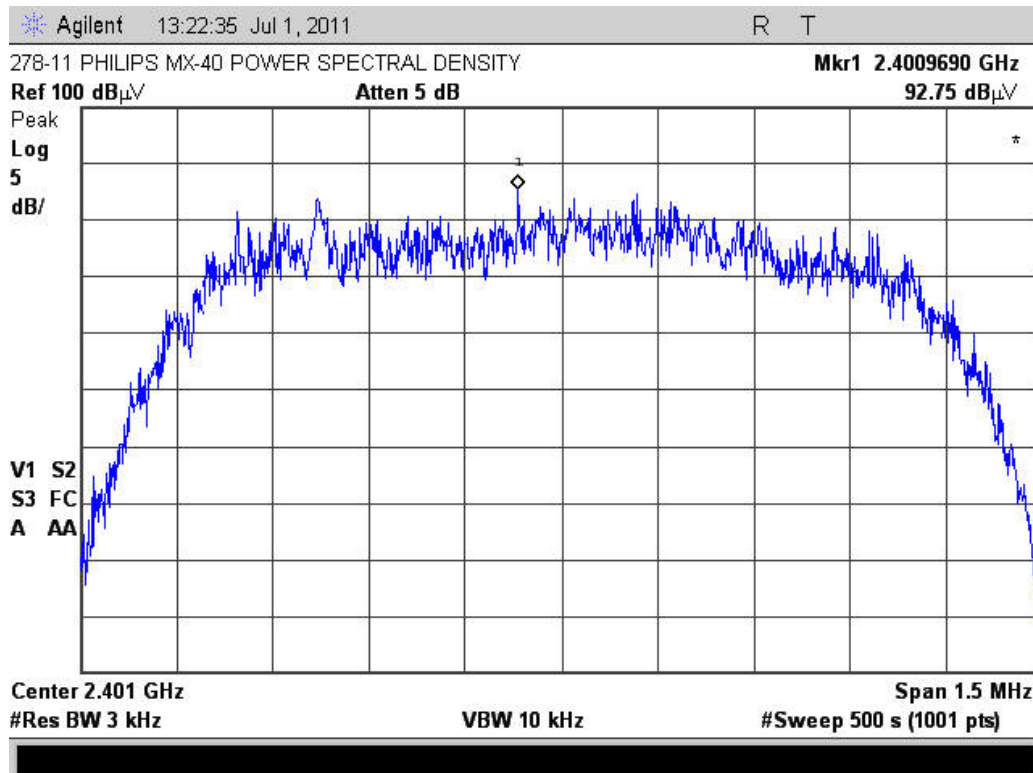

7. Measurement Data (continued)

7.9. Power Spectral Density (15.247(e))

7.9.2. Power Spectral Density Measurement Plot, Mid Channel – 24

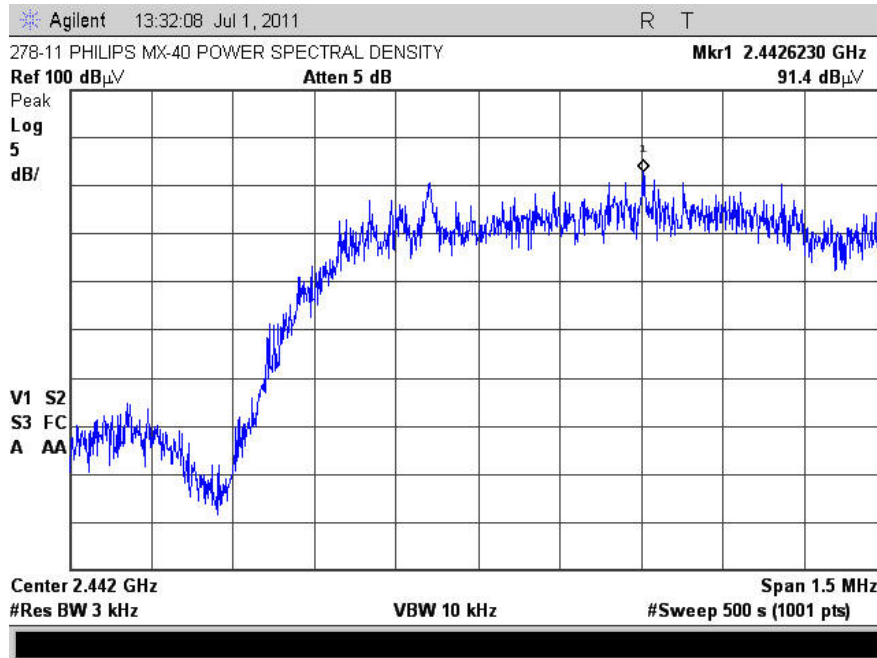

7.9.3. Power Spectral Density Measurement Plot, High Channel – 47

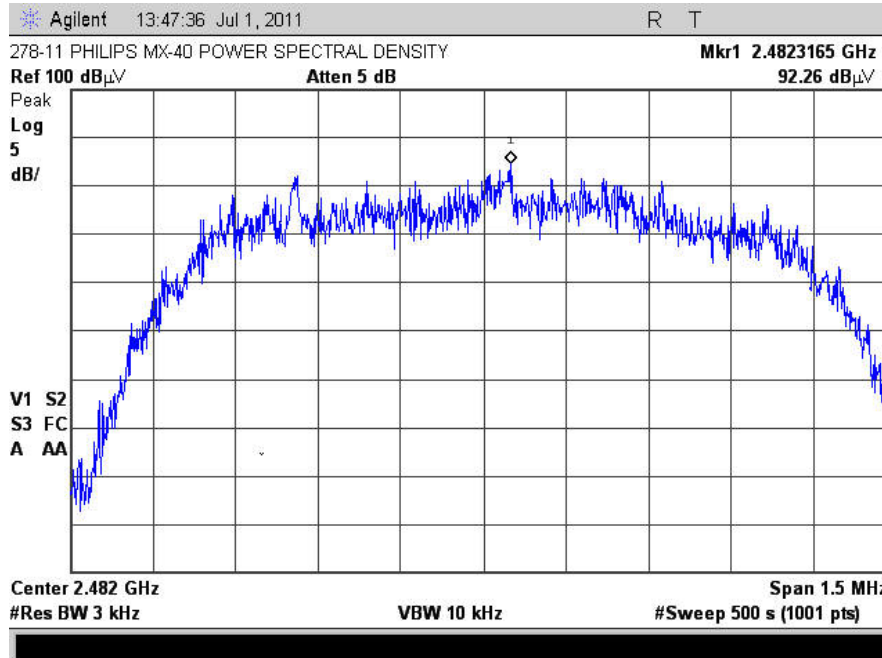

7. Measurement Data (continued)

7.10. Public Exposure to Radio Frequency Energy Levels (15.247(i) (1.1307 (b)(1))
RSS-GEN 5.5, RSS 102

Channel Frequency	MPE Distance (cm)	DUT Output Power (dBm)	DUT Antenna Gain (dBi)	Power Density		Limit (mW/cm ²)	Result
				(mW/cm ²)	(W/m ²)		
				(1)	(2)		
2401.060	2.5	15.40	-3.0	0.22126	2.21264	1	Compliant
2442.320	2.5	15.00	-3.0	0.20179	2.01795	1	Compliant
2482.252	2.5	13.70	-3.0	0.14959	1.49593	1	Compliant

$$PD = \frac{OP + AG}{(4 \times \pi \times d^2)}$$

- PD = Power Density (mW/cm²)
- OP = DUT Output Power (dBm)
- AG = DUT Antenna Gain (dBi)
- d = MPE Distance (cm)

1. Reference CFR 2.1093(b): For purposes of this section, a portable device is defined as a transmitting device designed to be used so that the radiating structure(s) of the device is/are within 2.5 centimeters of the body of the user.
2. Section 7.4 of this test report.
3. Data supplied by the client. Antenna specification data of worst case antenna used by the DUT.
4. Power density is calculated from field strength measurement and antenna gain.
5. Reference CFR 1.1310, Table 1: Limits for Maximum Permissible Exposure (MPE), Section (B): Limits for General Population/Uncontrolled Exposure.

7. Measurement Data (continued)

**7.10. Public Exposure to Radio Frequency Energy Levels (15.247(i) (1.1307 (b)(1))
RSS-GEN 5.5, RSS 102**

The calculated output power can be referenced in column 6 of the table below. The calculated peak output power is greater than the 24.17 mW requirement for performing SAR testing using the formula: $60 / F$ (GHz).

Channel	Frequency	Peak Field Strength	Distance	Antenna Gain ¹	Measured Output Power	Time Averaged Power
	(MHz)	(dB μ V/m)	(m)	(dBi)	(mW)	(mW)
Low	2401.1	107.60	3.0	-3.0	34.44	0.0086
Middle	2442.3	107.20	3.0	-3.0	31.41	0.0079
High	2482.3	105.90	3.0	-3.0	23.29	0.0058

However the time averaged power is significantly lower then the 24.17 mW requirement for 47CFR 1.1307 and 20 mW requirement for RSS-102

Channel Frequency (MHz)	Output Power (mW)	Time Averaging Duty Cycle Correction	Power Density		Limit (mW/cm ²)	Result
			(mW/cm ²)	(W/m ²)		
2401.060	34.44	0.01575	0.01051	0.10509	1	Compliant
2442.320	31.41	0.01575	0.00958	0.09584	1	Compliant
2482.252	23.29	0.01575	0.00710	0.07105	1	Compliant

RSS-102 Section 2.5, 2.5.1 & 2.5.2 Requirements:

2.5 - All transmitters are exempt from routine SAR and RF exposure evaluations provided that output power complies with the power levels of sections 2.5.1 or 2.5.2. If the equipment under test (EUT) meets the requirements of sections 2.5.1 or 2.5.2, applicants are only required to submit a properly signed declaration of compliance (see Annex C).

2.5.1 - SAR evaluation is required if the separation distance between the user and the radiating element of the device is less than or equal to 20 cm, except when the device operates as follows:

- above 2.2 GHz and up to 3 GHz inclusively, and with output power (i.e. the higher of the conducted or radiated (e.i.r.p.) source-based, time-averaged output power) that is less than or equal to 20 mW for general public use and 100 mW for controlled use

2.5.2 - RF exposure evaluation is required if the separation distance between the user and the device's radiating element is greater than 20 cm, except when the device operates as follows:

- at or above 1.5 GHz and the maximum e.i.r.p. of the device is equal to or less than 5 W.

7. Measurement Data (continued)

7.10. Public Exposure to Radio Frequency Energy Levels (15.247(i) (1.1307 (b)(1))
RSS-GEN 5.5, RSS 102 (continued)

Time Average Reduction = $20 \log (1.575 \text{ mS} / 100 \text{ mS}) = -36.05 \text{ dB}$

7.10.1 Determination of time averaged output power – 3 Pulses in 100 mS

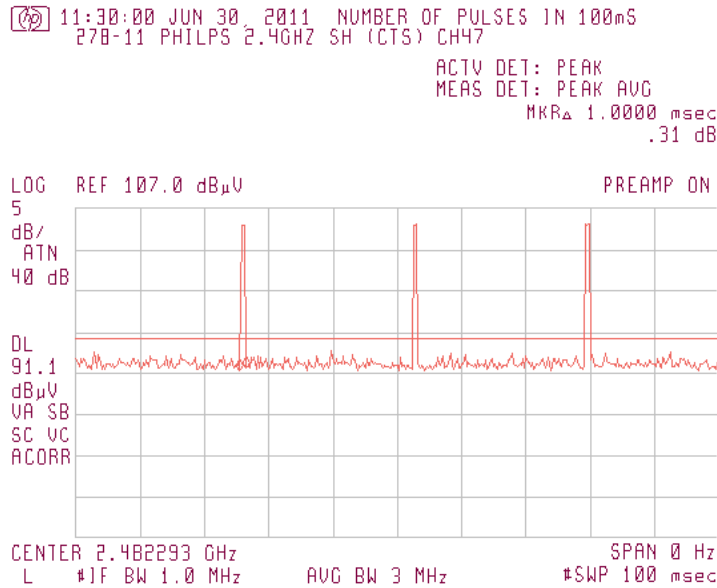

7.10.2 Determination of time averaged output power – Pulse width = 525 uS

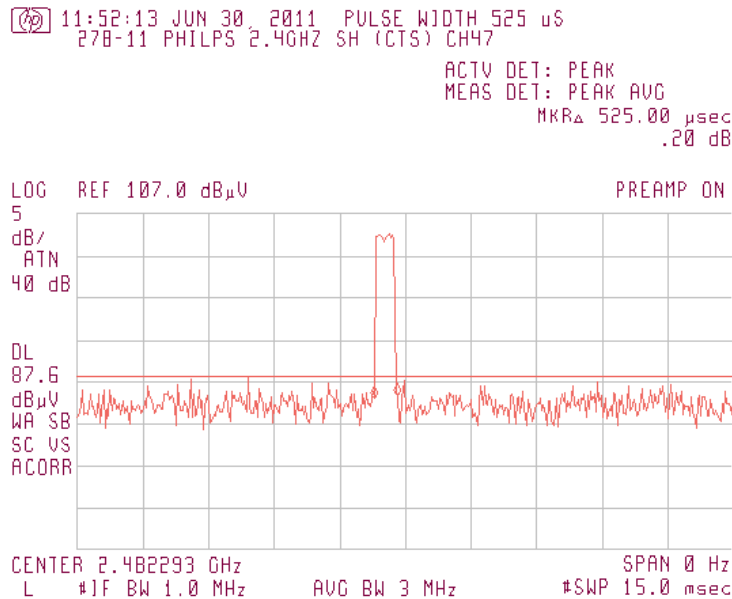

8. Test Setup Photographs

8.1. Radiated Emissions Front:



8. Test Setup Photographs

8.2. Radiated Emissions Rear:



9. Test Site Description

Compliance Worldwide is located at 357 Main Street in Sandown, New Hampshire. The test sites at Compliance Worldwide are used for conducted and radiated emissions testing in accordance with Federal Communications Commission (FCC) and Industry Canada standards. A description of the test sites is on file with the FCC (registration number **96392**) and Industry Canada (file number **IC 3023A-1**).

The radiated emissions test site is a 3 and 10 meter enclosed open area test site (OATS). Personnel, support equipment and test equipment are located in the basement beneath the OATS ground plane.

The conducted emissions site is part of a 16' x 20' x 12' ferrite tile chamber and uses one of the walls for the vertical ground plane required by EN 55022.

Both sites are designed to test products or systems 1.5 meter W x 1.5 meter L x 2.0 meter H, floor standing or table top.