

**COMPLIANCE WORLDWIDE INC.
TEST REPORT 134-17R1**

**In Accordance with the Requirements of
Federal Communications Commission
CFR 47 Part 95, Subpart H
Wireless Medical Telemetry Devices
In the bands 1395-1400 and 1427-1432 MHz**

Issued to

**Philips Medical Systems
3000 Minuteman Drive
Andover, MA 01810
978-659-2800**

for the

**Philips IntelliVue
IntelliVue 1.4 GHz Remote Antenna**

FCC ID: PQC-4843D

Report Issued on May 4, 2017

Tested by



Brian F. Breault

Reviewed by



Larry K. Stillings

Table of Contents

1. Scope.....	3
2. Product Details.....	3
2.1. Manufacturer	3
2.2. Model Number	3
2.3. Serial Number.....	3
2.4. Description.....	3
2.5. Power Source	3
2.6. EMC Modifications.....	3
3. Product Configuration	3
3.1. Operational Characteristics & Software.....	3
3.2. EUT Hardware.....	4
3.3. EUT Cables/Transducers	4
3.4. Support Equipment.....	4
3.5. Support Equipment Cables/Transducers.....	4
3.6. Miscellaneous.....	5
3.7. Block Diagram	5
4. Measurements Parameters.....	6
4.1. Measurement Equipment and Software Used to Perform Test	6
4.2. Measurement & Equipment Setup.....	6
4.3. Test Procedure	7
4.4. Measurement Uncertainty	7
5. Choice of Equipment for Test Suits	7
5.1. Choice of Model.....	7
5.2. Presentation	7
5.3. Choice of Operating Frequencies	7
5.4. Normal and Extreme Modes of Operation	7
6. Measurement Summary.....	8
7. Measurement Data	9
7.1. Occupied Bandwidth.....	9
7.2. Radiated Field Strength of Fundamental.....	12
7.3. Effective Radiated Power	15
7.4. Combined Radiated Field Strength of Harmonics	18
7.5. Band Edge.....	19
7.6. Spurious Radiated Emissions.....	23
7.7. Frequency Stability	30
7.8. Public Exposure to Radio Frequency Energy Levels	33
8. Test Setup Photographs	37
9. Test Site Description.....	48

1. Scope

This test report certifies that the IntelliVue 1.4 GHz Remote Antenna meets the Federal Communications Commission CFR 47, PART 95 requirement as tested. The scope of this test report is limited to the test sample provided by the client, only in as much as that sample represents other production units. If any significant changes are made to the unit, the changes shall be evaluated and a retest may be required. R1 to remove conducted emissions section not required.

2. Product Details

- 2.1. Manufacturer:** Philips Medical Systems
- 2.2. Model Number:** 867151/ITS4846A/453564656031
- 2.3 Serial Number:** DK64400022
- 2.4 Description of EUT:** 1.4 GHz Cluster Access Point Remote Antenna
- 2.5 Power Source:** DC 5 volts (powered by 866394/ 453564235171 access point).
- 2.6 Hardware Revision:** 1637
- 2.7 Software Revision:** N/A
- 2.8. Modulation Type:** FSK with Root Raised Cosine Filtering
- 2.9. Operating Frequency:** 1395–1400 MHz and 1427–1429.5 WMTS Frequency Band. Also reference Part 2.106 (2)(1) 1427-1432 MHz Medical Operations Band
- 2.10. EMC Modifications:** None

3. Product Configuration

3.1. Operational Characteristics & Software

For all tests, to ensure the RF communication is between the Remote Antenna and not the Cluster Access Point. Remove the antennas and cap the antenna ports on the Cluster AP with copper tape.

For Radiated Emissions and Radiated Immunity, only the remote antenna is to be in the chamber. The MX40 shall also be in the chamber placed in the corner to maximize its RF performance and to not have a negative effect on the test.

Connect system per block diagram. Turn on UPS. System willpower up. Type “Run-sdprocess” from the “Start” menu. The IntelliVue Information Central Station Monitoring application will load – this takes several minutes. Place the batteries in the MX40. Patient waveforms and numeric value will displayed on the IntelliVue Information Center display. Connect the simulators to the MX40 accessories.

EUT Performance Characteristics

Function	Monitored Parameter	Performance Specification	Additional Comments
Radio/LAN	Patient traffic	N/A	Continuous bi-directional communication resulting on continuous display of patient parameters

3. Product Configuration (continued)

3.2. EUT Hardware

Bik Diag #	Manufactr	Model/Part # / Options	Serial Number	Input Voltage	Frq (Hz)	Description/Function
1	Philips	453564473931	DK64400022	5V	DC	1.4 GHz Cluster Access Point Remote Antenna (includes antennas P/N 22990030/453564656051/A) FCC Test Sample

3.3. EUT Cables/Transducers

Bik Diag Ltr	Manufactr	Model/Part #	Length (m)	Shield Y/N	Description/Function
A	Philips R&D	453564656041	22	Y	Combination Coax/Cat 5 UTP LAN cable Rev. A

3.4. Support Equipment

Bik Diag #	Manufactr	Model/Part # Options	Serial Number	Input Voltage	Input Frq.	Description/Function
2	Philips	866394/ 453564235171	US40612733	48	DC	1.4 GHz CTS Access Point
3	Philips	M4844A/ 453563495101	US42200058	100-240	50/60	Synchronization Box
4	Hewlett-Packard	2520-8/J9173A	CN235DP0JD	100/240	50/60	Power-over-Ethernet switch
5	Cisco	WS-C2950T-24	FOC0816X1OJ	100/240	50/60	Ethernet Switch
6	HP/Philips	H1S81UC#ABA/453 564310461	2UA30409Y4	100-240	50/60	IntelliVue Information Center
7	Philips	170S8FB/27	AU3A0809006103	100/240	50/60	17 inch display
8	Philips	453564195161/ ITS3171A	SG24002644	100/240	50/60	Access Point Controller
9	Tripplite	SMART500RT1U	9336ALCSM513901271	100/240	50/60	Uninterruptible Power Supply
10	DNI Nevada	OxiTest Plus7	DOS03040647	120	60	DOS03040647
11	Dale	Dale14	203927	9	DC	ECG Simulator
12	Philips	MX40/865350/C01 C03 J46 M02 S02	US096Z3494	3.7 - 4.5 V	DC	1.4 GHz CTS Patient Worn Monitor

3.5. Support Equipment Cables/Transducers

Bik Diag Ltr	Manufactr	Model/Part #	Length (m)	Shield Y/N	Description/Function
B	Philips	M1191A	3	Y	SpO2 transducer
C	N/A	N/A	Various	N	Category 5 UTP LAN cable
D	Philips	989803171871	0.8	Y	ECG lead set

3. Product Configuration (continued)

3.6. Miscellaneous (e.g., consumables, test fixtures, etc.):

Blk Diag Ltr	Manufactr	Model/Part #	Qty	Description/Function
None	Duracell	N/A	3	AA batteries for the PWM

3.7. Block Diagram

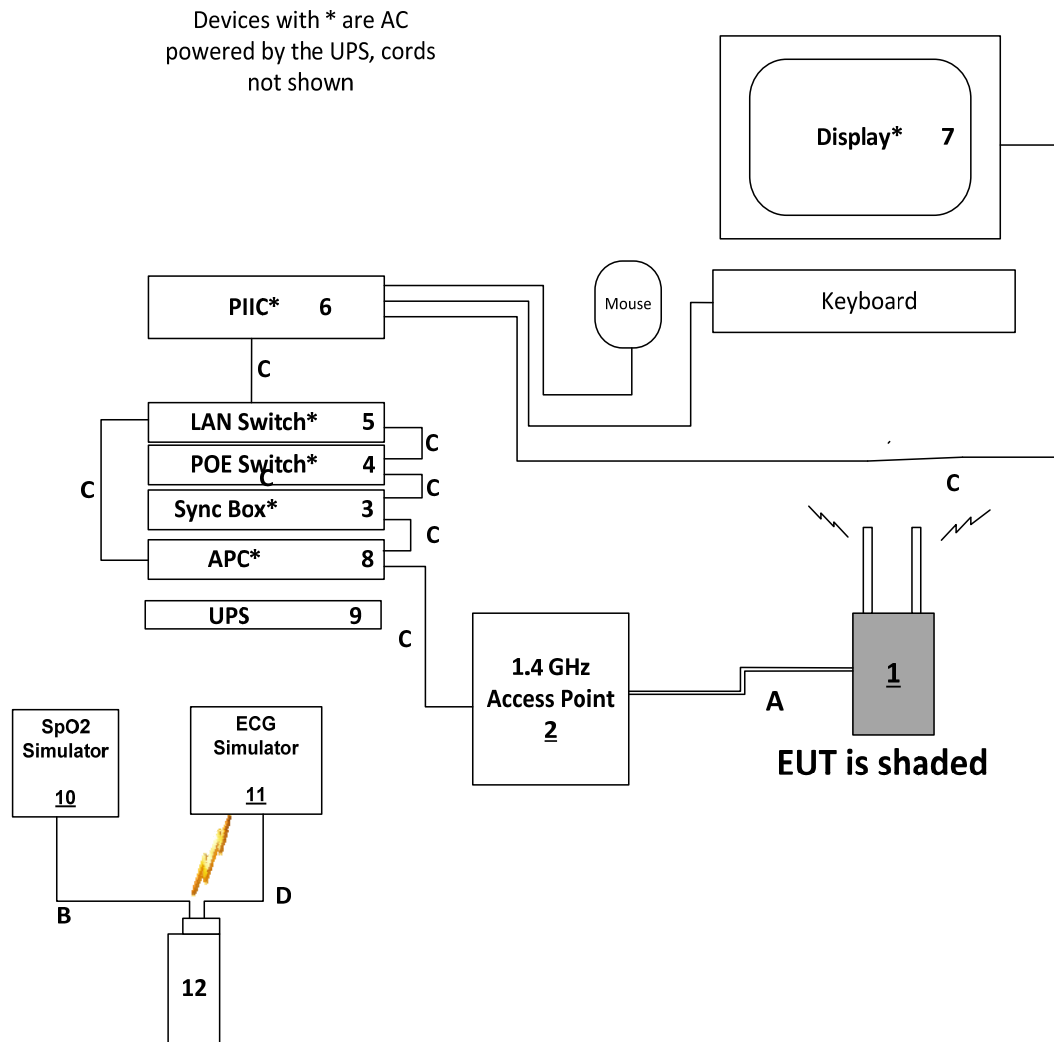

4. Measurements Parameters

4.1. Measurement Equipment and Software Used to Perform Test

Device	Manufacturer	Model No.	Serial No.	Cal Due	Interval
EMI Test Receiver, 9kHz - 7GHz ¹	Rohde & Schwarz	ESR7	101156	7/23/2017	2 Years
Spectrum Analyzer 20 Hz – 40 GHz ²	Rohde & Schwarz	FSV40	100899	7/23/2017	2 Years
Spectrum Analyzer, 9 kHz - 40 GHz ³	Rohde & Schwarz	FSVR40	100909	7/23/2017	2 Years
EMI Receiver	Hewlett Packard	8546A	3330A00115	6/4/2017	3 Years
Passive Loop Antenna, 9 kHz to 30 MHz	EMCO	6512	9309-1139	10/26/2018	2 Years
Biconilog Antenna, 30 MHz to 2 GHz	Sunol Sciences	JB1	A050913	6/3/2019	2 Years
Horn Antenna, 960 MHz to 18 GHz	Electro-Metrics	EM-6961	6337	5/2/2018	1 Year
Horn Antenna, 18 GHz to 40 GHz	Com-Power	AH-840	101032	2/24/2018	2 Years
Preamplifier, 1 GHz to 26.5 GHz	Hewlett Packard	8449B	3008A00329	7/22/17	2 Years
LISN 50 ohm 50 µH, 9 kHz to 30 MHz	EMCO	3825/2	9109-1860	11/17/2017	1 Year
High Pass Filter, 2500 to 19300 MHz	Micro-Tronics	HPM50110	070	6/1/2017	1 Year
Power Splitter/Combiner, DC to 4.2 GHz	RF Bay, Inc.	PSC-2R-42	14110124	6/1/2017	1 Year
EMI Receiver, 9 kHz to 6.5 GHz	Hewlett Packard	8546A	3330A00115	12/4/2018	2 Years
Digital Barometer	Control Company	4195	ID236	10/8/2017	2 Years
Power Supply ⁴	Hewlett Packard		6296A	NR	---
Digital Multi-meter	Fluke	187	83030167	11/21/2017	1 Year
Temperature Chamber ⁴	Associated Research	E-0029	N/A	NR	---

¹ ESR7 Firmware revision: V2.26, Date installed: 08/15/2014 Previous V2.17, installed 6/11/2014.
² FSV40 Firmware revision: V2.30 SP4, Date installed: 05/04/2016 Previous V2.30 SP1, installed 10/22/2014.
³ FSVR40 Firmware revision: V2.23, Date installed: 10/20/2014 Previous V1.63 SP1, installed 8/28/2013.
⁴ These devices are used with calibrated measurement equipment.

Manufacturer	Software Description	Title or Model #	Rev.	Report Sections
Compliance Worldwide	Test Report Generation Software	Test Report Generator	1.0	Used to process conducted emissions data

4.2. Measurement & Equipment Setup

Test Dates: Feb 6th - Feb 21st, 2017
 Test Engineer: Brian Breault
 Normal Site Temperature (15 - 35°C): 24.0
 Relative Humidity (20 -75%RH): 33%
 Frequency Range: 10 kHz to 15 GHz
 Measurement Distance: 3 Meters
 EMI Receiver IF Bandwidth: 120 kHz - 30 MHz to 1 GHz
 1 MHz - Above 1 GHz
 EMI Receiver Avg Bandwidth: 300 kHz - 30 MHz to 1 GHz
 3 MHz - Above 1 GHz
 Detector Function: Peak, QP - 30 MHz to 1 GHz
 Peak, Avg - Above 1 GHz
 Unless otherwise specified.

4. Measurements Parameters (continued)

4.3. Test Procedure

All references to CFR 47 PART 95, Subpart H - Wireless Medical Telemetry Service (WMTS) - refer to the 10-1-16 edition.

The test methods used to generate the data in this test report is in accordance with ANSI C63.10:2013, American National Standard for Testing Unlicensed Wireless Devices.

4.4. Measurement Uncertainty

The following uncertainties are expressed for an expansion/coverage factor of K=2.

RF Frequency	$\pm 1 \times 10^{-8}$
Radiated Emission of Transmitter	± 4.55 dB
Radiated Emission of Receiver	± 4.55 dB
Temperature	$\pm 0.91^{\circ}$ C
Humidity	$\pm 5\%$

5. Choice of Equipment for Test Suits

5.1. Choice of Model

This test report is based on the test samples supplied by the manufacturer and are reported by the manufacturer to be equivalent to the production units.

5.2. Presentation

This test sample was tested complete with all required ancillary equipment. Refer to Section 3 of this report for product equipment configuration.

5.3. Choice of Operating Frequencies

The choice of operating frequencies selected for the testing outlined in this report was based on the lowest and highest operating frequencies in each of the two bands utilized by the device under test. The frequencies selected were 1395.9 MHz, 1399.1 MHz, 1427.9 MHz and 1431.1 MHz.

5.4. Normal and Extreme Modes of Operation

Manufacturers of wireless medical telemetry devices are responsible for ensuring frequency stability such that an emission is maintained within the band of operation under all of the manufacturer's specified conditions. The normal and extreme test modes are detailed in section 7.7 of this report.

5.5. Orthogonal Positions

During normal operation, the external antennas on the DUT are kept in one fixed position. Therefore, all tests were performed in the same manner and the requirement detailed in ANSI C63.10-2013, section 5.10.1 was not applied.

6. Measurement Summary

Transmitter Test Requirement	FCC Requirement	Test Report Section	Result	Comment
Product Labeling	95.1109(b)	N/A	N/A	See exhibits FCC label sample and label location.
Emission Type	95.1115(c)	N/A	N/A	Transmits Data and ECG Waveform
RF Safety	95.1125	N/A	N/A	Statement and Technical Basis
Occupied Bandwidth	95.1111(a)(2)	7.1	Compliant	
Radiated Field Strength of Fundamental	95.1115(a)(2)	7.2	Compliant	
Effective Radiated Power	95.1115(a)(3)	7.3	Compliant	
Radiated Field Strength of Harmonics	95.1115(b)(2)	7.4	Compliant	
Band Edge Measurements	95.1115(b)(2)	7.5	Compliant	
Spurious Radiated Emissions	95.1115(b)	7.6	Compliant	
Frequency Stability	95.1115 (e)	7.7	Compliant	
Public Exposure to Radio Frequency Energy Levels	95.1125 1.1310 2.1093(c)	7.8	Compliant	Measurements were made using the same requirements as mobile devices.

7. Measurement Data

7.1. Occupied Bandwidth

Requirement: The bandwidth is measured at an amplitude level reduced from the reference level by a specified ratio. The reference level is the level of the highest amplitude signal observed from the transmitter at either the fundamental frequency or the first-order modulation products in all typical modes of operation, including the unmodulated carrier, even if atypical. Once the reference level is established, the equipment is conditioned with typical modulating signals to produce the worst-case (i.e., the widest) bandwidth. If no bandwidth requirement is specified by the procuring or regulatory agency, measure the bandwidth at -26 dB with respect to the reference level.

Results: Compliant

Channel	Freq (MHz)	Bandwidth (MHz)
1	1395.9	1.412
3	1399.1	1.442
4	1427.9	1.442
6	1431.1	1.467

7.1.1. Channel 1, 1395.9 MHz

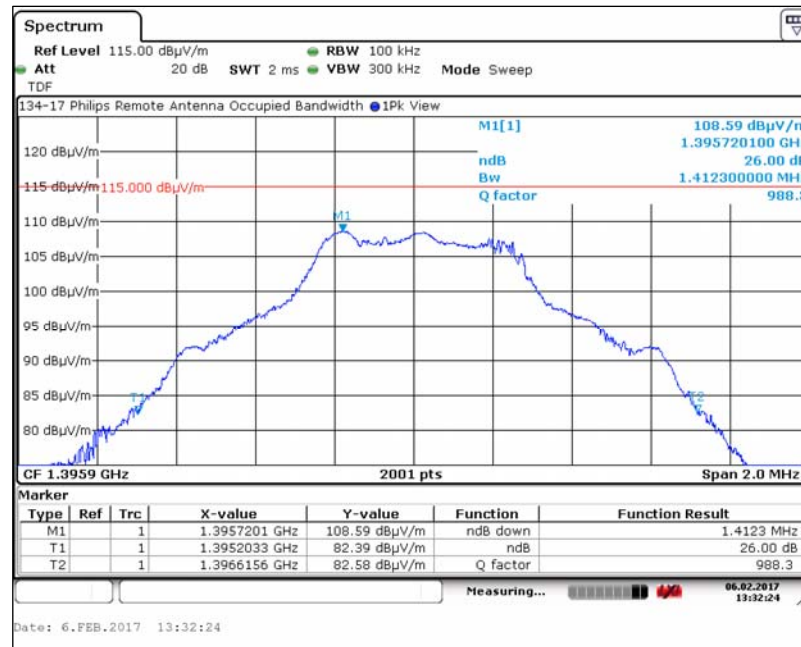

7. Measurement Data (continued)

7.1. Occupied Bandwidth (continued)

7.1.2. Channel 3, 1399.1 MHz

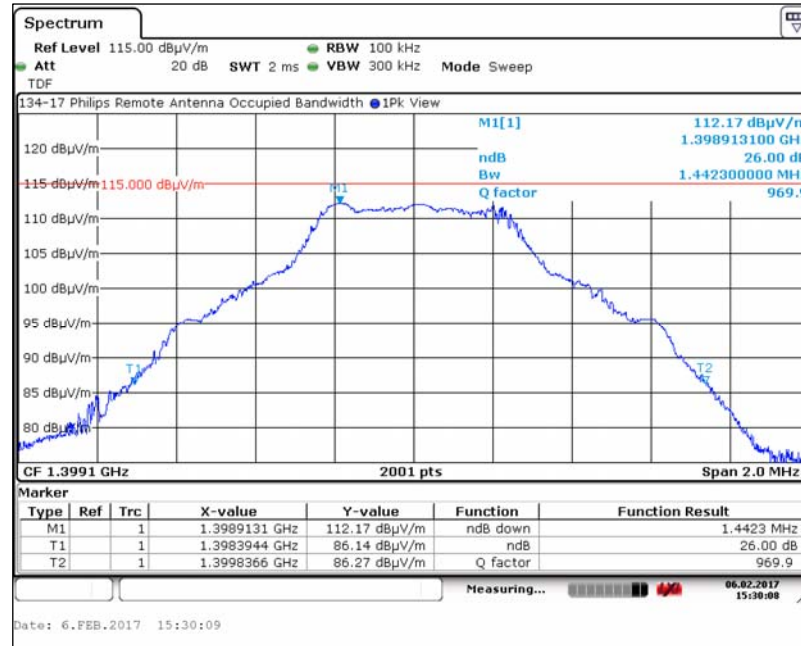

7.1.3. Channel 4, 1427.9 MHz

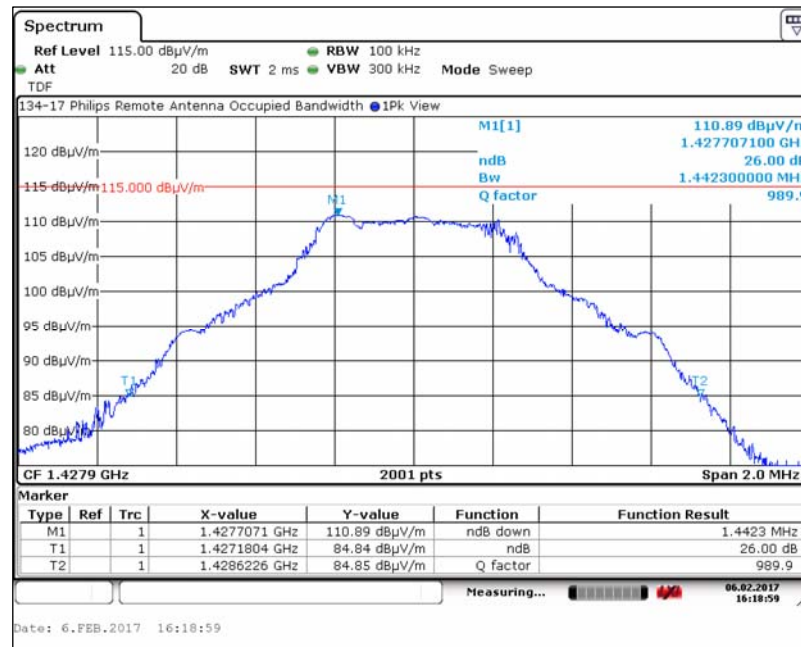

7. Measurement Data (continued)

7.1. Occupied Bandwidth (continued)

7.1.4. Channel 6, 1431.1 MHz

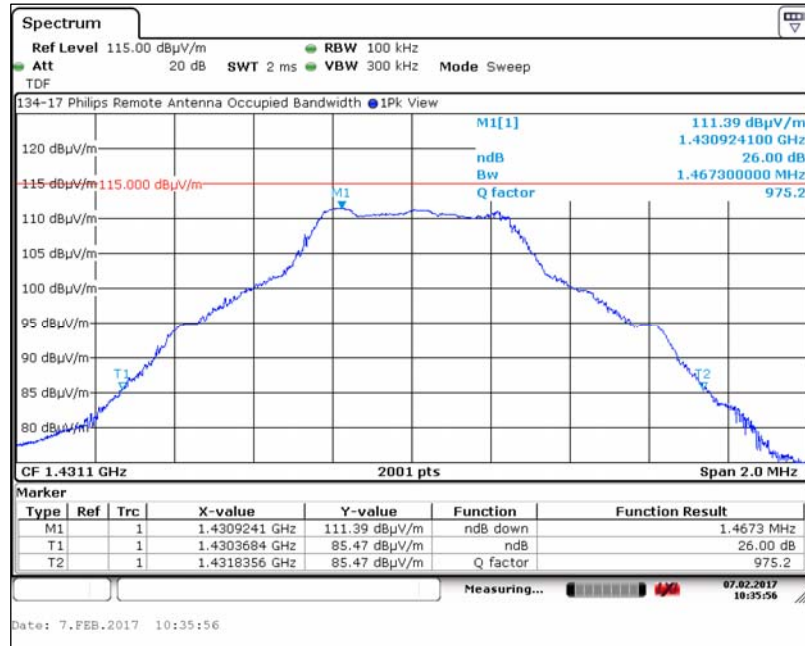

7. Measurement Data (continued)

7.2. Radiated Field Strength of Fundamental

Requirement: In the 1395–1400 MHz and 1427–1429.5 MHz bands, the maximum allowable field strength is 740 mV/m (117.4 dBμV/m), as measured at a distance of 3 meters, using measuring equipment with an averaging detector and a 1 MHz measurement bandwidth (§ 95.1115, (a)(2)).

When average radiated emission measurements are specified in this part, there also is a limit on the peak level of the radio frequency emissions. Unless otherwise specified, the limit on peak radio frequency emissions is 20 dB above the maximum permitted average emission limit applicable to the equipment under test.

Results: Compliant.

Table 1

Channel	Freq (MHz)	Field Strength (dBμV/m)		Limit (dBμV/m)		Peak Margin (dB)	Average Margin (dB)	Result
		Peak	Average	Peak	Average			
1	1395.9	112.28	76.88	137.4	117.4	-25.12	-40.52	Compliant
3	1399.1	112.26	76.94	137.4	117.4	-25.14	-40.46	Compliant
4	1427.9	110.94	75.31	137.4	117.4	-26.46	-42.09	Compliant
6	1431.1	111.56	77.37	137.4	117.4	-25.84	-40.03	Compliant

7.2.1. Channel 1

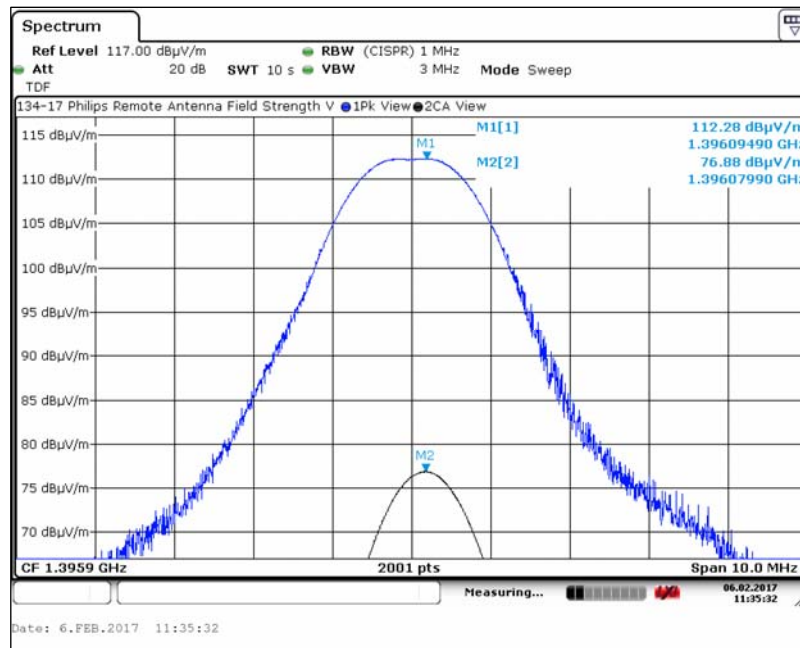

Test Number: 134-17R1

Issue Date: 5/4/2017

7. Measurement Data (continued)

7.2. Radiated Field Strength of Fundamental (continued)

7.2.2. Channel 3

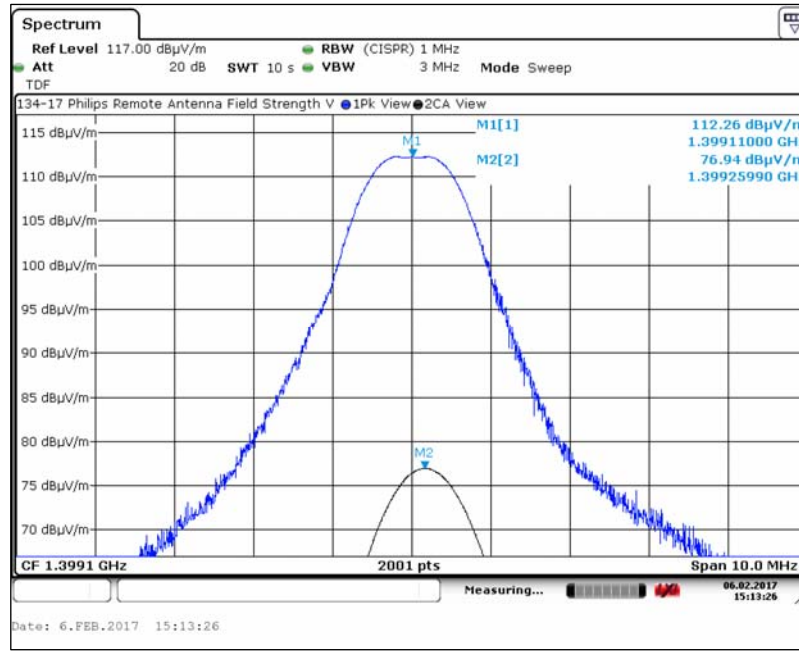

7.2.3. Channel 4

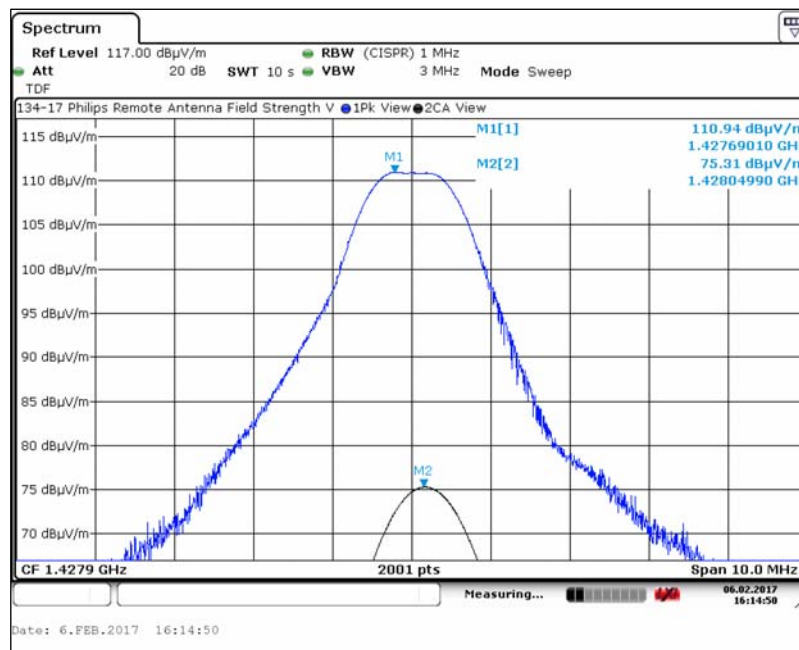

7. Measurement Data (continued)

7.2. Radiated Field Strength of Fundamental (continued)

7.2.4. Channel 6

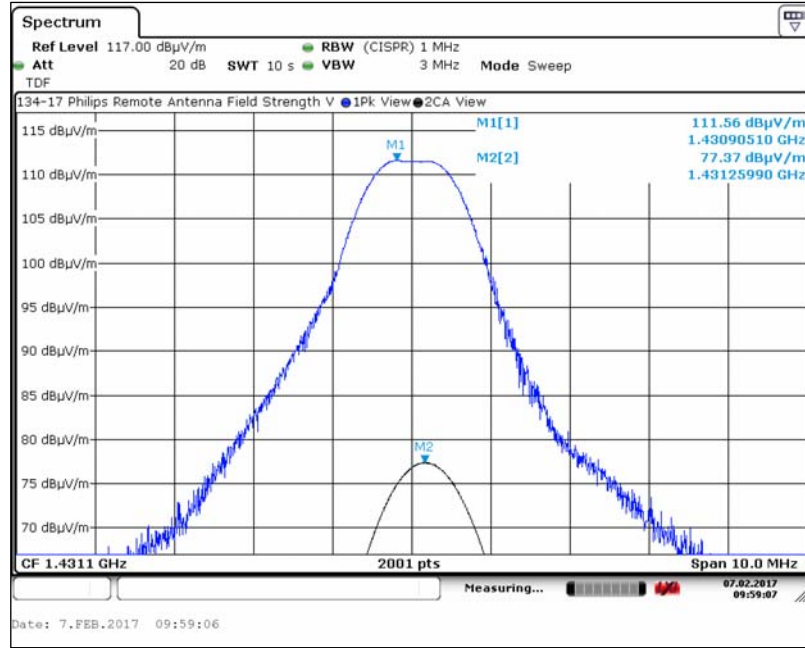

7. Measurement Data (continued)

7.3. Effective Radiated Power

Requirement: Prior to operation, authorized health care providers who desire to use wireless medical telemetry devices must register all devices with a designated frequency coordinator. The registration must include the following information: Effective radiated power. (95.1111(a)(3)).

Test Notes: The power measurements were made using the configuration detailed in the block diagram below. This configuration provided a ratio of -46.1 dB between the wanted (measured) and unwanted signals.

FCC OET 412172 (August 7, 2015): Determining ERP and EIRP, Section 1.2, was referenced to determine the effective radiated power of the device under test.

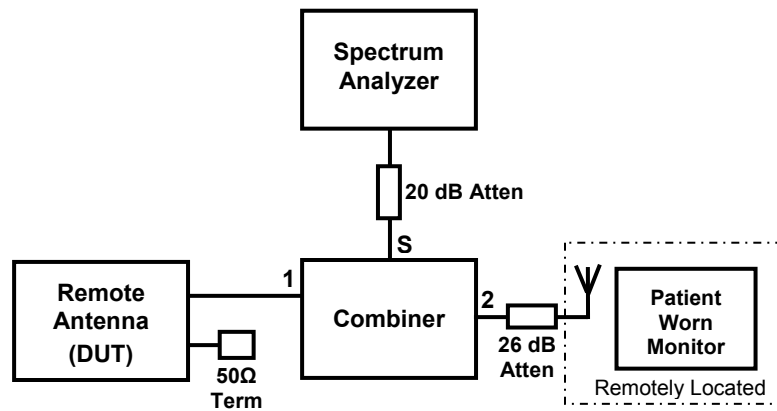

Effective Radiated Power Measurements

Chan.	Freq. (MHz)	Measured Power (dBm)	Correction Factors			Transmitter Output Power (P _T)		Ant Gain (G _T) (dBi)	ITS Ant Cable (L _C) (dBm)	EIRP (dB)	ERP (dBm)
			Cable (dB)	Combiner (dB)	20 dB Attn (dB)	(dBm)	(mW)				
		(1)	(2)	(3)	(4)	(5)	(6)	(7)	(8)	(9)	(10)
1	1395.9	-13.81	0.23	6.39	19.82	12.63	18.323	2.00	0.00	14.63	12.48
3	1399.1	-13.91	0.24	6.39	19.82	12.54	17.947	2.00	0.00	14.54	12.39
4	1427.9	-14.83	0.20	6.39	19.82	11.58	14.388	2.00	0.00	13.58	11.43
6	1431.1	-14.99	0.21	6.40	19.82	11.44	13.932	2.00	0.00	13.44	11.29

EIRP = P_T + G_T + L_C

- 1 Spectrum analyzer measurement. See 7.3.1 – 7.3.4.
- 2 - 4 All insertion loss components.
- 5 & 6 Power delivered to the DUT external antenna port. Transmit out power (P_T) includes the internal ITS cable (L_C).
- 7 Antenna gain
- 8 ITS Module cable insertion loss. See 6 & 7.
- 9 EIRP = P_T + G_T + L_C
- 10 ERP = EIRP - 2.15 dB

7. Measurement Data (continued)

7.3. Effective Radiated Power

7.3.1. Channel 1 Measured Power

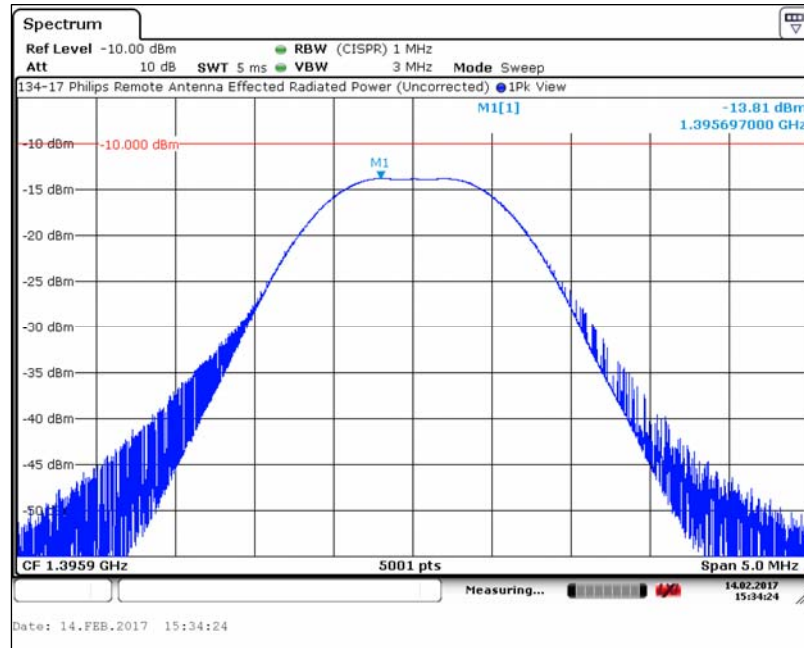

7.3.2. Channel 3 Measured Power

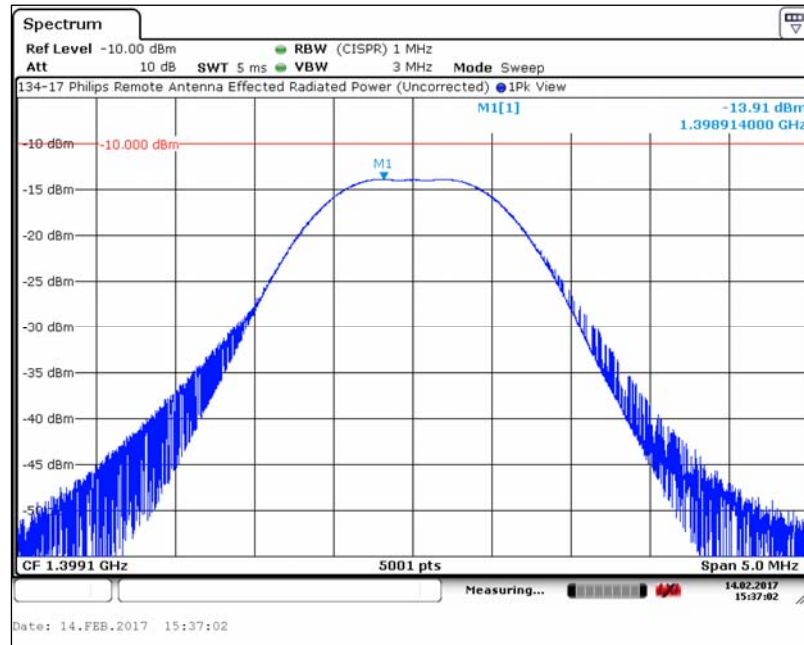

7. Measurement Data (continued)

7.3. Effective Radiated Power

7.3.3. Channel 4 Measured Power

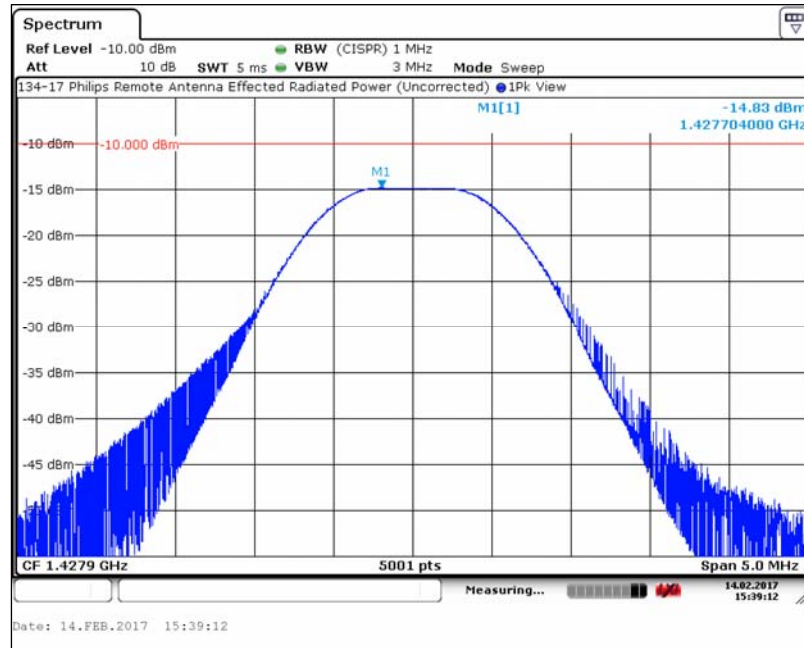

7.3.4. Channel 6 Measured Power

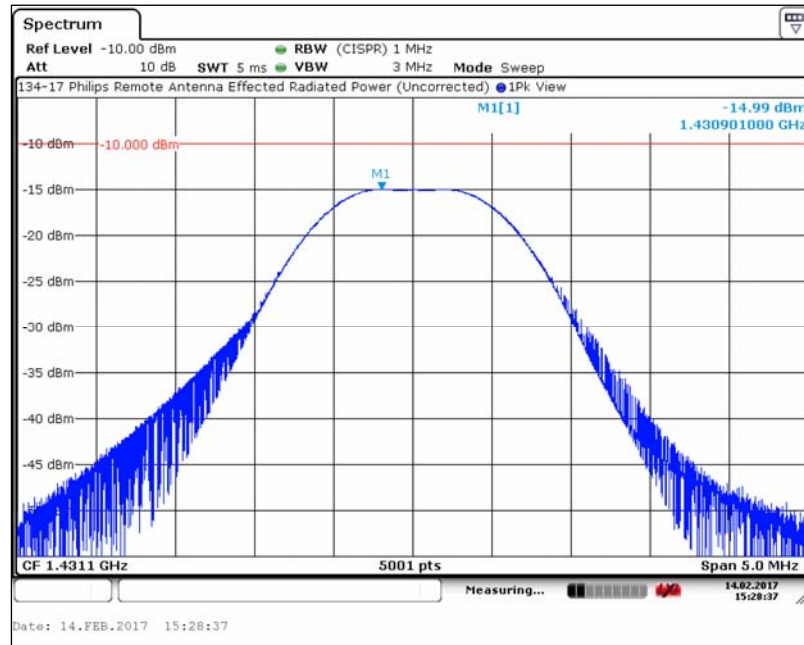

7. Measurement Data (continued)

7.4. Combined Radiated Field Strength of Harmonics

Requirement: Out-of-band emissions above 960 MHz are limited to 500 microvolts/meter as measured at a distance of 3 meters, using measuring equipment with an averaging detector and a 1 MHz RBW (§ 95.1115, (b)(2)).

Results: Compliant.

Frequency (MHz)	Field Strength (dBµV/m)		Limit (dBµV/m)		Margin (dB)		Antenna Polarity (H/V)
	Peak	Avg	Peak	Avg	Peak	Avg	
2791.8	46.10	31.10	74	54	-27.90	-22.90	V
2798.2	49.25	32.28	74	54	-24.75	-21.72	H
2855.8	47.95	31.39	74	54	-74.00	-54.00	H
2862.2	51.76	31.29	74	54	-22.24	-22.71	H
4187.7	56.86	34.12	74	54	-17.14	-19.88	V
4197.3	57.57	34.42	74	54	-16.43	-19.58	H
4283.7	55.54	33.66	74	54	-18.46	-20.34	H
4293.3	55.70	33.92	74	54	-18.30	-20.08	V
5583.6	52.13	35.42	74	54	-21.87	-18.58	H
5596.4	53.03	35.48	74	54	-20.97	-18.52	V
5711.6	52.09	35.03	74	54	-74.00	-54.00	V
5724.4	50.58	34.64	74	54	-23.42	-19.36	H
6979.5	50.76	35.84	74	54	-23.24	-18.16	H
6995.5	50.63	36.88	74	54	-23.37	-17.12	V
7139.5	50.94	36.99	74	54	-23.06	-17.01	V
7155.5	49.71	36.16	74	54	-24.29	-17.84	H
8375.4	56.09	38.14	74	54	-17.91	-15.86	H
8394.6	55.64	38.21	74	54	-18.36	-15.79	V
8567.4	56.31	38.36	74	54	-17.69	-15.64	V
8586.6	55.96	37.82	74	54	-18.04	-16.18	V
9771.3	53.72	39.72	74	54	-20.28	-14.28	V
9793.7	54.45	40.32	74	54	-19.55	-13.68	V
9995.3	54.47	40.10	74	54	-19.53	-13.90	H
10017.7	53.65	39.66	74	54	-20.35	-14.34	H
11167.2	55.35	41.45	74	54	-18.65	-12.55	H
11192.8	55.78	41.71	74	54	-18.22	-12.29	H
11423.2	55.82	41.31	74	54	-18.18	-12.69	V
11448.8	55.04	40.34	74	54	-18.96	-13.66	V
12563.1	57.19	43.40	74	54	-16.81	-10.60	H
12591.9	58.43	44.37	74	54	-15.57	-9.63	V
12851.1	57.52	43.61	74	54	-16.48	-10.39	H
12879.9	56.88	43.11	74	54	-17.12	-10.89	H
13959.0	57.70	43.91	74	54	-16.30	-10.09	V
13991.0	58.39	44.01	74	54	-15.61	-9.99	H
14279.0	57.84	44.35	74	54	-16.16	-9.65	H
14311.0	57.76	44.23	74	54	-16.24	-9.77	H

7. Measurement Data (continued)

7.5. Band Edge

Requirement: Out-of-band emissions above 960 MHz are limited to 500 microvolts per meter (54 dB μ V/m) as measured at a distance of 3 meters, using measuring equipment with an averaging detector and a 1 MHz measurement bandwidth.

Test Note: The marker-delta method was used to determine the band edge and worst case out of band values in the following tables. Reference ANSI C63.10-2013, section 6.10.6 for details on this method.

The data detailed in the following tables are factored by taking the peak and average radiated field strength measurement values from section 7.2 and subtracting the offset values determined from the band edge calculation plots in section 7.5.5.

Results: Compliant

7.5.1. Lower Band Edge (1395–1400) (Offset Value = 40.78 dB)

Chan. 1 (MHz)	Field Strength (dB μ V/m)		Band Edge Frequency (MHz)	Field Strength (dB μ V/m)		Average Limit (dB μ V/m)	Margin (dB)	Result
	Peak	Average		Peak	Average			
1395.9	112.28	76.88	1395	71.50	36.10	54	-17.9	Compliant

Worst Case Out of Band (1395–1400) (Offset Value = 39.90 dB)

Chan. 1 (MHz)	Field Strength (dB μ V/m)		Out of Band Frequency (MHz)	Field Strength (dB μ V/m)		Average Limit (dB μ V/m)	Margin (dB)	Result
	Peak	Average		Peak	Average			
1395.9	112.28	76.88	1394.7393	72.38	36.98	54	-17.02	Compliant

7.5.2. Upper Band Edge (1395–1400) (Offset Value = 43.97 dB)

Chan. 3 (MHz)	Field Strength (dB μ V/m)		Band Edge Frequency (MHz)	Field Strength (dB μ V/m)		Average Limit (dB μ V/m)	Margin (dB)	Result
	Peak	Average		Peak	Average			
1399.1	112.26	76.94	1400	68.29	32.97	54	-21.03	Compliant

Worst Case Out of Band (1395–1400) (Offset Value = 39.81 dB)

Chan. 3 (MHz)	Field Strength (dB μ V/m)		Out of Band Frequency (MHz)	Field Strength (dB μ V/m)		Average Limit (dB μ V/m)	Margin (dB)	Result
	Peak	Average		Peak	Average			
1399.1	112.26	76.94	1400.2338	72.45	37.13	54	-16.87	Compliant

7. Measurement Data (continued)

7.5. Band Edge (continued)

7.5.3. Lower Band Edge (1427–1429.5) (Offset Value = 39.41 dB)

Chan. 4 (MHz)	Field Strength (dBµV/m)		Band Edge Frequency (MHz)	Field Strength (dBµV/m)		Average Limit (dBµV/m)	Margin (dB)	Result
	Peak	Average		Peak	Average			
1427.9	110.94	75.31	1427	71.53	35.90	54	-18.10	Compliant

Worst Case Out of Band (1427–1429.5) (Offset Value = 39.74 dB)

Chan. 4 (MHz)	Field Strength (dBµV/m)		Band Edge Frequency (MHz)	Field Strength (dBµV/m)		Average Limit (dBµV/m)	Margin (dB)	Result
	Peak	Average		Peak	Average			
1427.9	110.94	75.31	1426.7632	71.20	35.57	54	-18.43	Compliant

7.5.4. Upper Band Edge (1427–1429.5) (Offset Value = 44.30 dB)

Chan. 6 (MHz)	Field Strength (dBµV/m)		Band Edge Frequency (MHz)	Field Strength (dBµV/m)		Average Limit (dBµV/m)	Margin (dB)	Result
	Peak	Average		Peak	Average			
1431.1	111.56	77.37	1432	67.26	33.07	54	-20.93	Compliant

Worst Case Out of Band (1427–1429.5) (Offset Value = 39.98 dB)

Chan. 6 (MHz)	Field Strength (dBµV/m)		Band Edge Frequency (MHz)	Field Strength (dBµV/m)		Average Limit (dBµV/m)	Margin (dB)	Result
	Peak	Average		Peak	Average			
1431.1	111.56	77.37	1432.2458	71.58	37.39	54	-16.61	Compliant

7. Measurement Data (continued)

7.5. Band Edge

7.5.5. Band Edge Calculation Plots

7.5.5.1. Lower Band Edge and Worst Case Out of Band (1395–1400)



7.5.5.2. Upper Band Edge and Worst Case Out of Band (1395–1400)

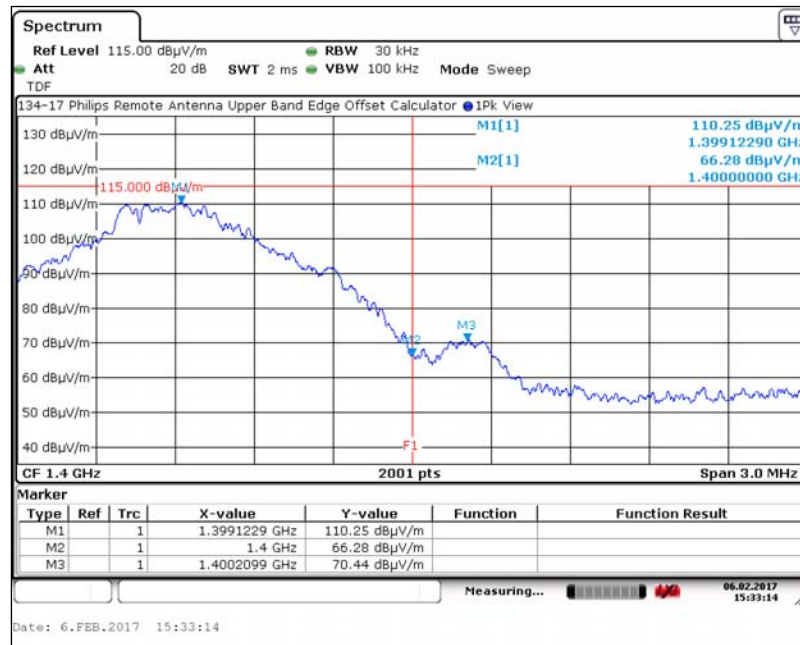

7. Measurement Data (continued)

7.5. Band Edge

7.5.5. Band Edge Calculation Plots

7.5.5.3. Lower Band Edge and Worst Case Out of Band (1427–1429.5)

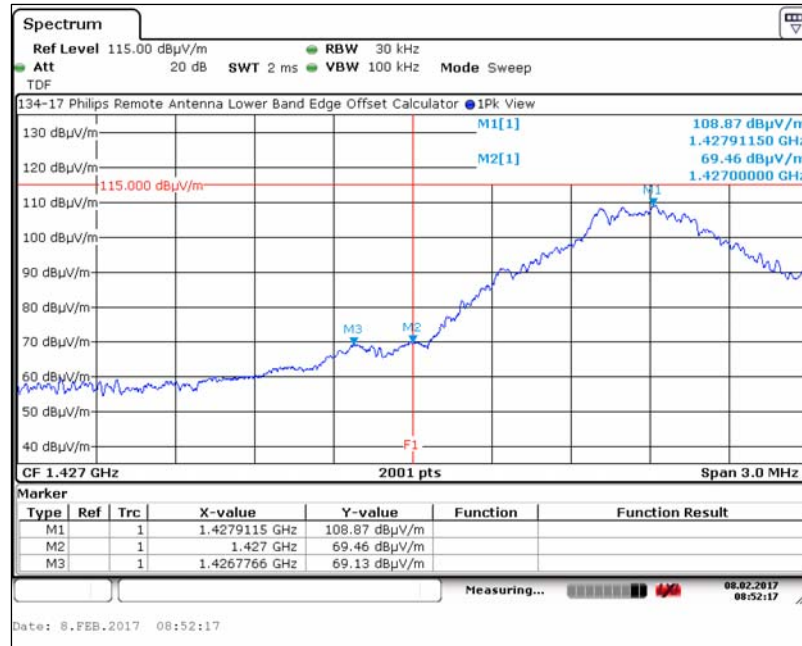

7.5.5.4. Upper Band Edge and Worst Case Out of Band (1427–1429.5)

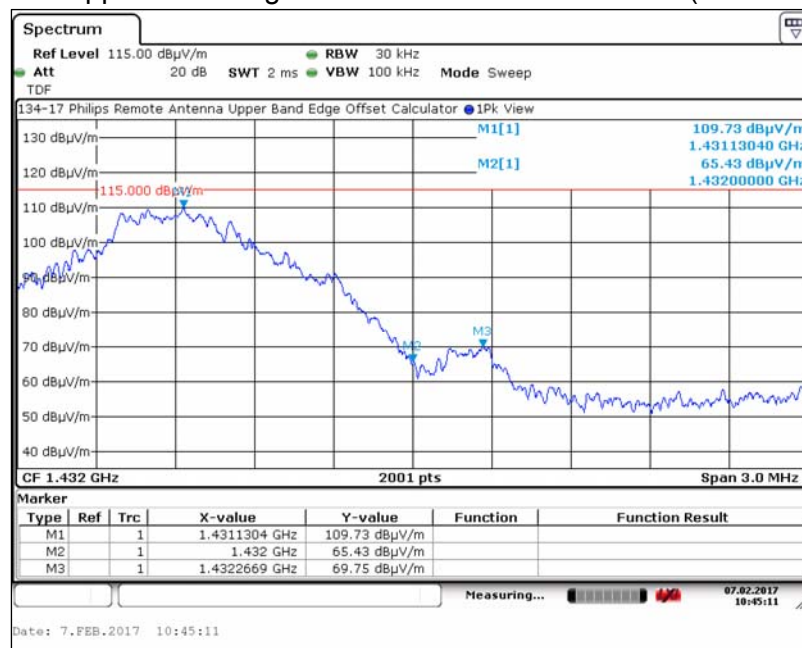

7. Measurement Data (continued)

7.6. Spurious Radiated Emissions

Regulatory Limit: FCC Part 209, Quasi-Peak¹

Frequency Range (MHz)	Distance (Meters)	Limit (dBµV/m) ¹
0.009 to 0.490	3	128.5 to 93.8
0.490 to 1.705	3	73.8 to 63.0
1.705 to 30	3	69.5
30 to 88	3	40.0
88 to 216	3	43.5
216 to 960	3	46.0
>960	3	54.0

¹ Measurements in the 9 to 90 kHz, 110 to 490 kHz and above 1000 MHz ranges employ an average detector. Otherwise a quasi-peak detector is used.

Requirement: Out-of-band emissions below 960 MHz are limited to 200 µV/meter (46 dBµV/m), as measured at a distance of 3 meters, using measuring instrumentation with a CISPR quasi-peak detector.

Out-of-band emissions above 960 MHz are limited to 500 µV/meter as measured at a distance of 3 meters, using measuring equipment with an averaging detector and a 1 MHz measurement bandwidth.

Test Procedure: Test measurements were made in accordance with ANSI C63.10-2013, American National Standard for Testing Unlicensed Wireless Devices.

Test Notes: The FCC Part 15.209 requirements for radiated emissions were used for spurious emissions testing. This requirement meets or exceeds the FCC Part 95, Subpart H requirements. The device under test was tested while running in normal operational mode.

Results: The DUT is meets the FCC Part 15.209 requirements for radiated emissions.

7. Measurement Data (continued)

7.6. Spurious Radiated Emissions (continued)

7.6.1. 10 kHz to 150 kHz

Parallel Antenna

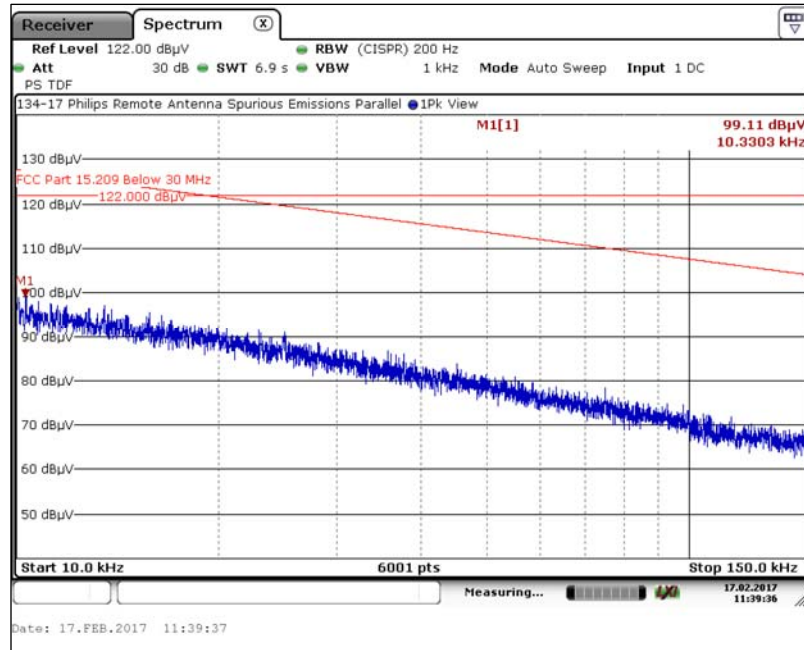

Perpendicular Antenna

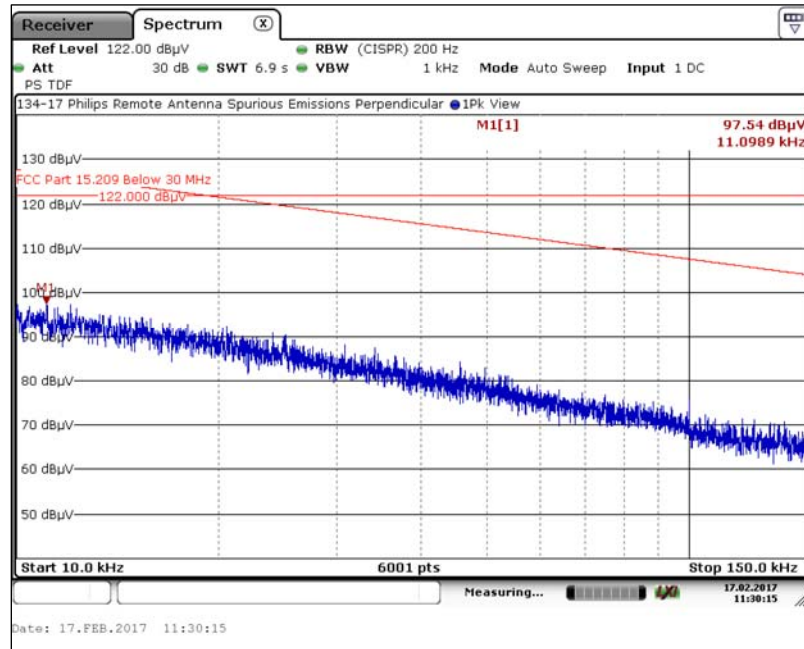

7. Measurement Data (continued)

7.6. Spurious Radiated Emissions (continued)

7.6.2. 150 kHz to 30 MHz

Parallel Antenna

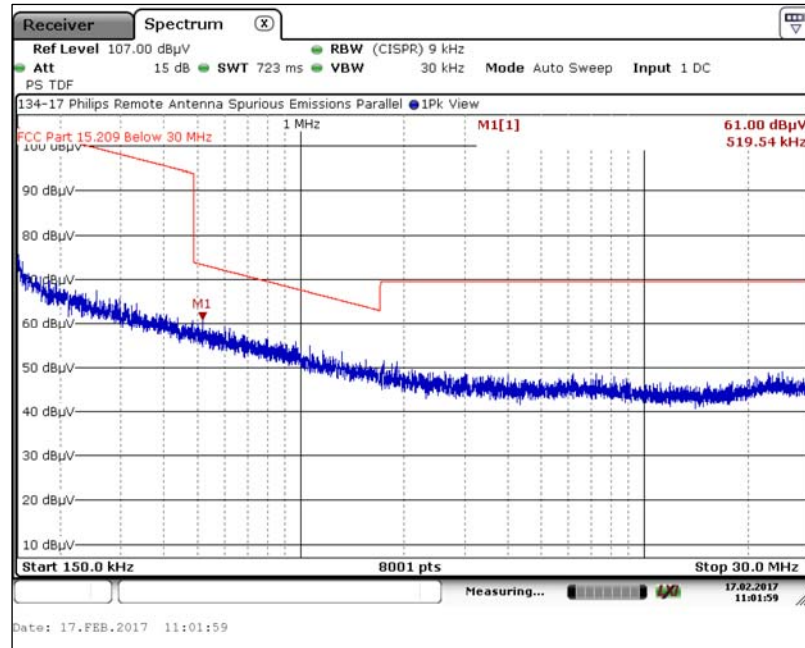

Perpendicular Antenna

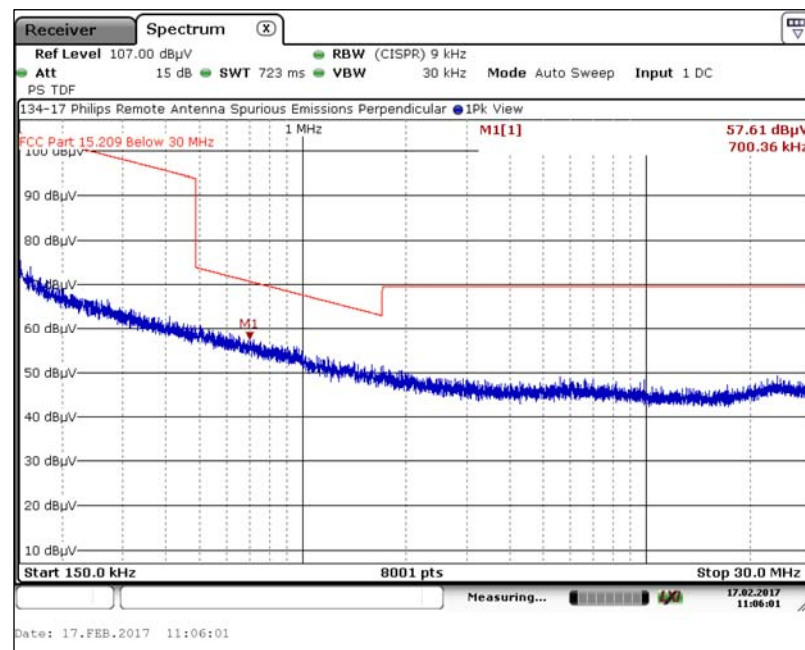

7. Measurement Data (continued)

7.6. Spurious Radiated Emissions (continued)

7.6.3. 30 MHz to 1 GHz

Horizontal Antenna

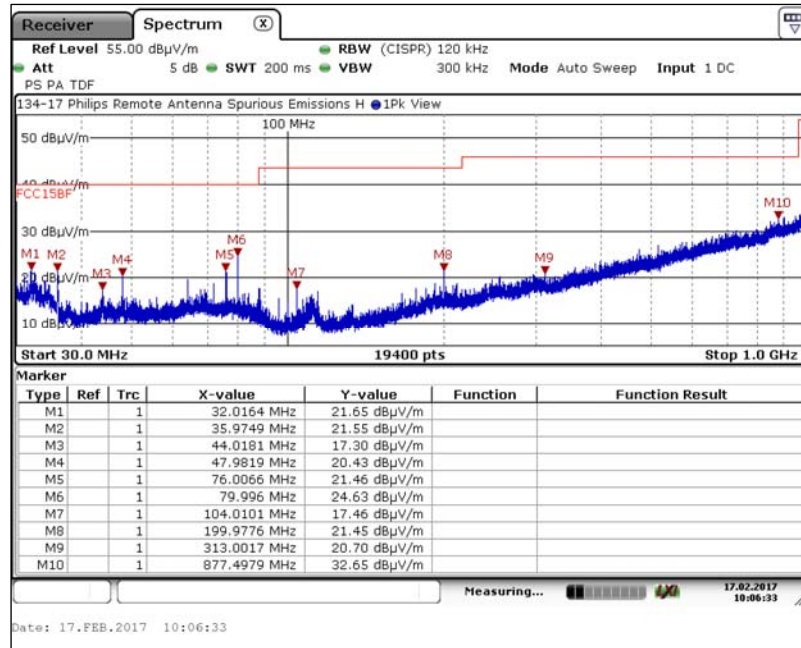

Vertical Antenna

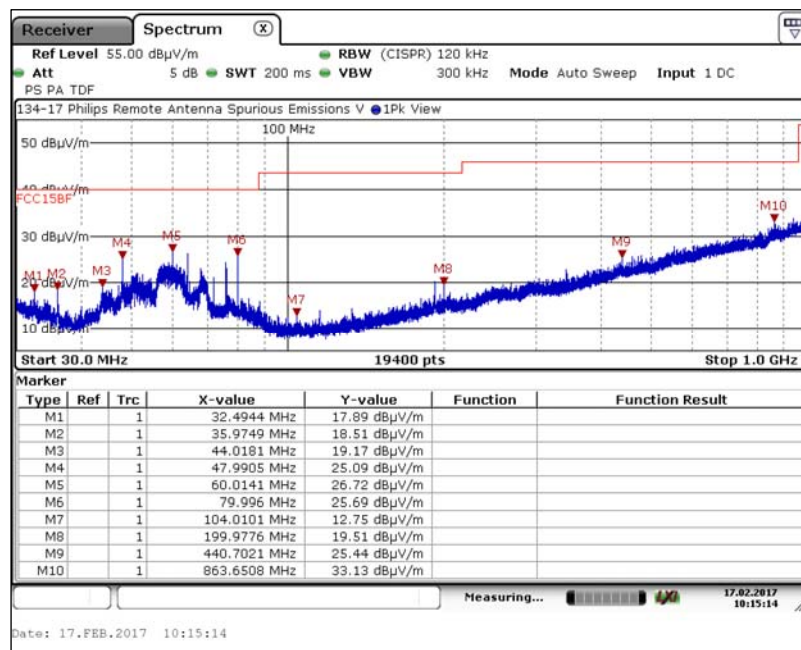

7. Measurement Data (continued)

7.6. Spurious Radiated Emissions (continued)

7.6.4. 1 GHz to 7 GHz

Horizontal Antenna

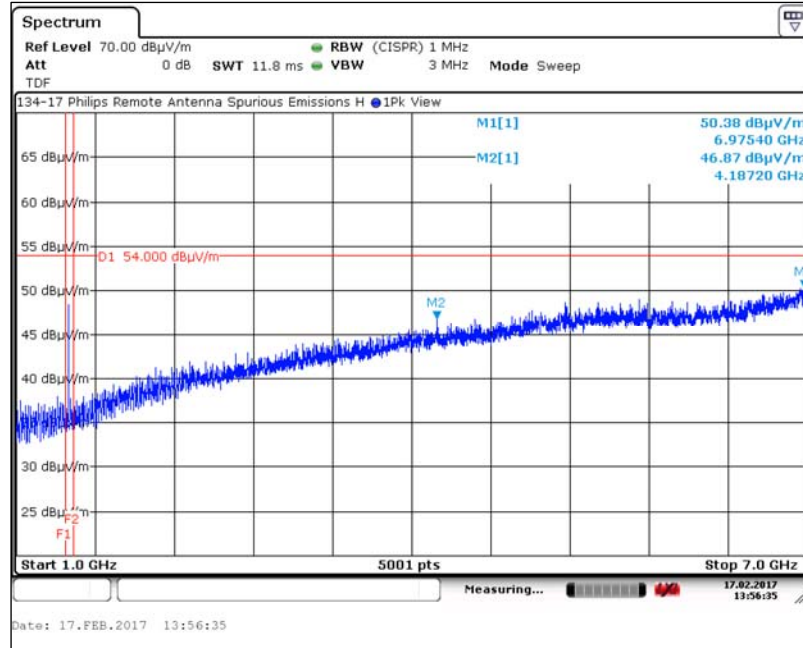

Vertical Antenna

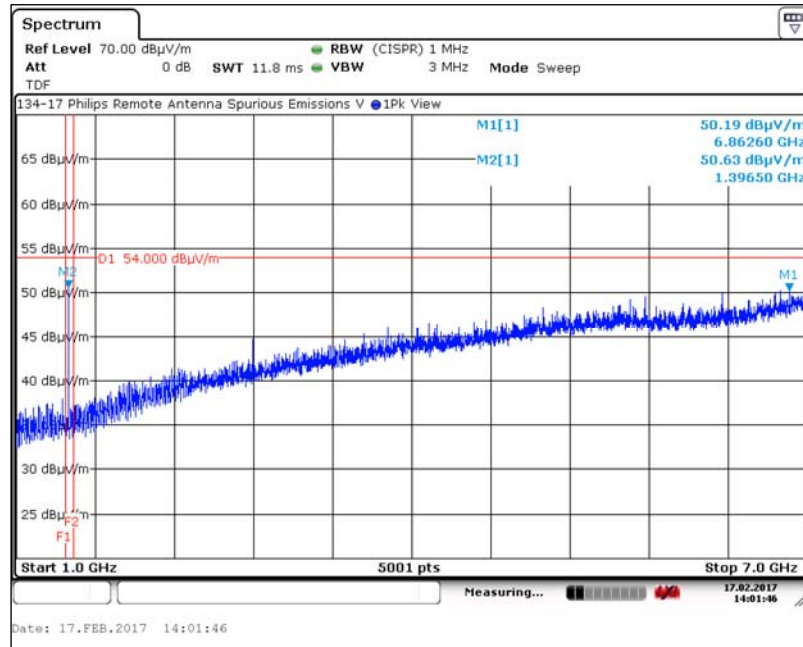

7. Measurement Data (continued)

7.6. Spurious Radiated Emissions (continued)

7.6.5. 7 GHz to 15 GHz

Horizontal Antenna

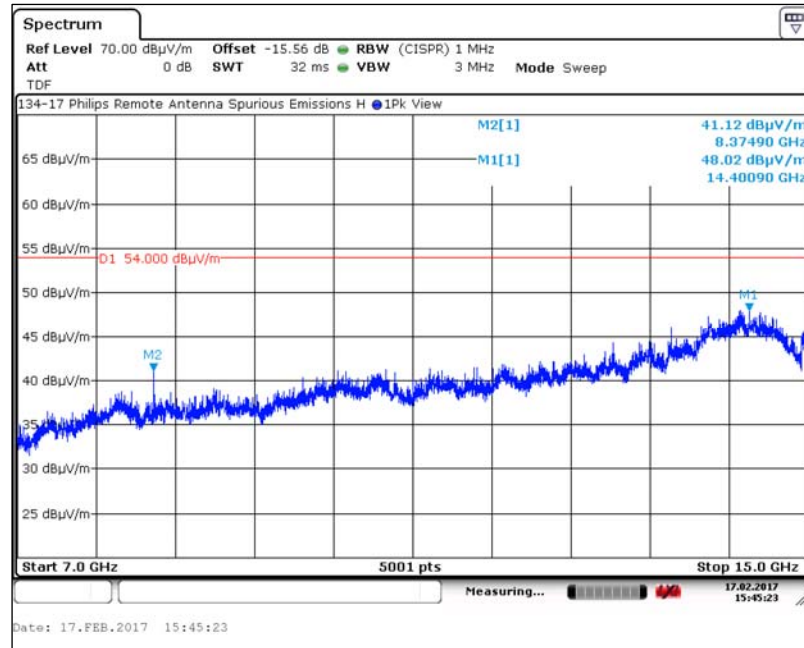

Vertical Antenna

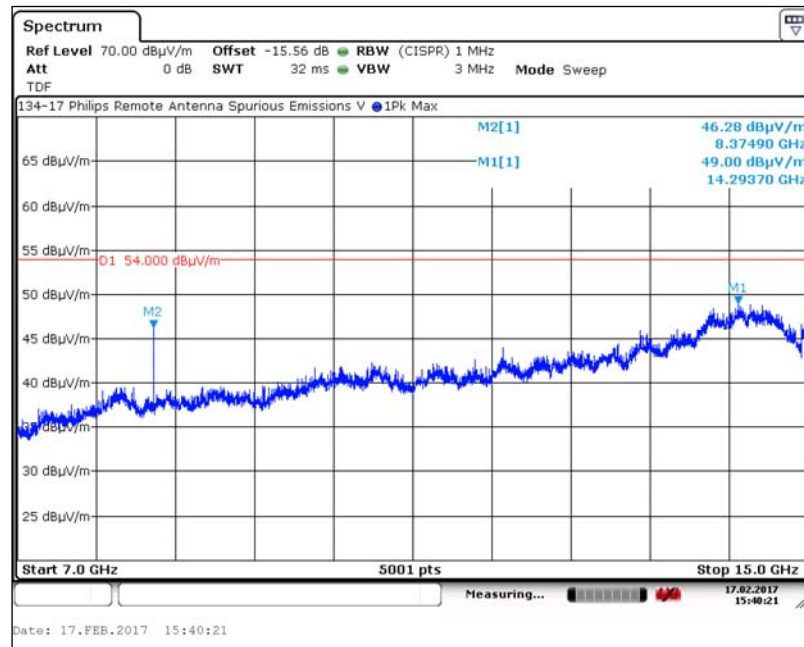

7. Measurement Data (continued)

7.6. Spurious Radiated Emissions (continued)

7.6.6. 7.5 GHz to 15 GHz

Horizontal Antenna

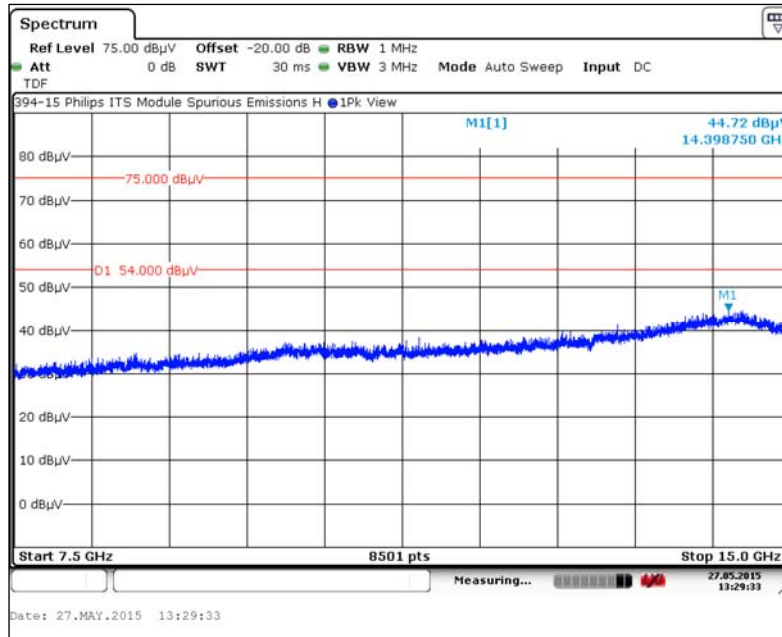

Vertical Antenna

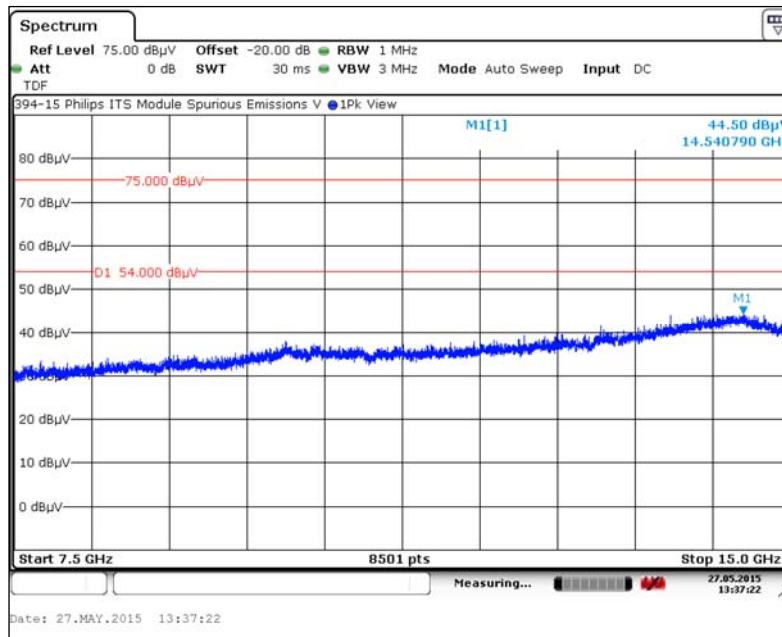

7. Measurement Data (continued)**7.7. Frequency Stability (FCC 95.1115 (e))**

Requirement: Manufacturers of wireless medical telemetry devices are responsible for ensuring frequency stability such that an emission is maintained within the band of operation under all of the manufacturer's specified conditions.

Nominal Temperature : 21.7 °C
Temperature Tolerance : Lower : 0 °C
Upper : 55 °C
Philips Medical requirement

Nominal Voltage : 48.0 Volts DC
Voltage Tolerance : Lower : 37 Volts DC
Upper : 57 Volts DC
Voltage tolerance is based on the conditions provided in the following test note.

Test Note: The Remote Antenna (DUT) was powered directly by the Philips 866394 Access Point 5 volt DC output specifically designed for this application. This interface, by design, cannot be altered. The Access Point POE voltage, in turn, was powered by a variable power supply. This supply was varied from a minimum of 37 volts DC to a maximum of 57 volts DC in accordance with the IEEE 802.3af (802.3at Type 1): Power Over Ethernet Voltage range at PD (Powered Device) specification.

Results: The DUT remains well within the WMTS bands.

7. Measurement Data (continued)

7.7. Frequency Stability (FCC 95.1115 (e)) (continued)

Channel 1

Assigned Freq.	Temperature	Voltage	Meas. Frequency	Meas. Freq. -½Bandwidth	Band Edge	Result
GHz	Deg. C	VDC	MHz	MHz	MHz	
1395.9	Nominal	Nominal	1395.9051	1395.2033	1395	Compliant
		37.0	1395.9048	1395.1987	1395	Compliant
		57.0	1395.9171	1395.2109	1395	Compliant
	55	37.0	1395.8454	1395.1393	1395	Compliant
		57.0	1395.9078	1395.2017	1395	Compliant
	45	37.0	1395.9075	1395.2013	1395	Compliant
		57.0	1395.9126	1395.2064	1395	Compliant
	35	37.0	1395.9141	1395.2079	1395	Compliant
		57.0	1395.9111	1395.2049	1395	Compliant
	25	37.0	1395.9162	1395.2101	1395	Compliant
		57.0	1395.9102	1395.2041	1395	Compliant
	15	37.0	1395.9159	1395.2098	1395	Compliant
		57.0	1395.9030	1395.1969	1395	Compliant
	5	37.0	1395.9093	1395.2032	1395	Compliant
		57.0	1395.9069	1395.2008	1395	Compliant
	0	37.0	1395.9108	1395.2046	1395	Compliant
		57.0	1395.9207	1395.2145	1395	Compliant

Channel 3

Assigned Freq.	Temperature	Voltage	Meas. Frequency	Meas. Freq. + ½Bandwidth	Band Edge	Result
GHz	Deg. C	VDC	MHz	MHz	MHz	
1399.1	Nominal	Nominal	1399.0985	1399.8366	1400	Compliant
		37.0	1399.1009	1399.8046	1400	Compliant
		57.0	1399.1075	1399.8112	1400	Compliant
	55	37.0	1399.1034	1399.8071	1400	Compliant
		57.0	1399.1180	1399.8216	1400	Compliant
	45	37.0	1399.1186	1399.8222	1400	Compliant
		57.0	1399.1168	1399.8204	1400	Compliant
	35	37.0	1399.1045	1399.8082	1400	Compliant
		57.0	1399.1033	1399.8069	1400	Compliant
	25	37.0	1399.1189	1399.8225	1400	Compliant
		57.0	1399.1237	1399.8273	1400	Compliant
	15	37.0	1399.1057	1399.8094	1400	Compliant
		57.0	1399.1033	1399.8070	1400	Compliant
	5	37.0	1399.1084	1399.8120	1400	Compliant
		57.0	1399.1018	1399.8055	1400	Compliant
	0	37.0	1399.1147	1399.8183	1400	Compliant
		Nominal	1399.0985	1399.8366	1400	Compliant

7. Measurement Data (continued)

7.7. Frequency Stability (FCC 95.1115 (e)) (continued)

Channel 4

Assigned Freq.	Temperature	Voltage	Meas. Frequency	Meas. Freq. - 1/2 Bandwidth	Band Edge	Result
GHz	Deg. C	VDC	MHz	MHz	MHz	
1427.9	Nominal	Nominal	1427.9090	1427.1804	1427	Compliant
		37.0	1427.8985	1427.1774	1427	Compliant
		57.0	1427.9003	1427.1792	1427	Compliant
	55	37.0	1427.9048	1427.1837	1427	Compliant
		57.0	1427.9132	1427.1920	1427	Compliant
	45	37.0	1427.9135	1427.1923	1427	Compliant
		57.0	1427.8970	1427.1759	1427	Compliant
	35	37.0	1427.9030	1427.1819	1427	Compliant
		57.0	1427.9201	1427.1989	1427	Compliant
	25	37.0	1427.9087	1427.1876	1427	Compliant
		57.0	1427.9174	1427.1962	1427	Compliant
	15	37.0	1427.9069	1427.1858	1427	Compliant
		57.0	1427.9030	1427.1819	1427	Compliant
	5	37.0	1427.9162	1427.1950	1427	Compliant
		57.0	1427.9048	1427.1837	1427	Compliant
	0	37.0	1427.9138	1427.1927	1427	Compliant
		57	1427.9003	1427.1792	1427	Compliant

Channel 6

Assigned Freq.	Temperature	Voltage	Meas. Frequency	Meas. Freq. + 1/2 Bandwidth	Band Edge	Result
GHz	Deg. C	VDC	MHz	MHz	MHz	
1431.1	Nominal	Nominal	1431.0985	1431.8356	1432	Compliant
		37.0	1431.1030	1431.8367	1432	Compliant
		57.0	1431.0955	1431.8292	1432	Compliant
	55	37.0	1431.1222	1431.8558	1432	Compliant
		57.0	1431.1174	1431.8510	1432	Compliant
	45	37.0	1431.1108	1431.8445	1432	Compliant
		57.0	1431.1087	1431.8423	1432	Compliant
	35	37.0	1431.1045	1431.8382	1432	Compliant
		57.0	1431.0979	1431.8316	1432	Compliant
	25	37.0	1431.1078	1431.8414	1432	Compliant
		57.0	1431.0985	1431.8322	1432	Compliant
	15	37.0	1431.1119	1431.8455	1432	Compliant
		57.0	1431.1021	1431.8358	1432	Compliant
	5	37.0	1431.1117	1431.8453	1432	Compliant
		57.0	1431.1015	1431.8352	1432	Compliant
	0	37.0	1431.1078	1431.8415	1432	Compliant
		57.0	1431.1033	1431.8369	1432	Compliant

7. Measurement Data (continued)

7.8. Public Exposure to Radio Frequency Energy Levels (95.1125, 1.1307 (b)(1))

Requirement: Mobile devices, as defined in section 2.1091(b), are subject to radio frequency radiation exposure requirements. In this report, the requirements for devices used in a fixed location have been accessed the same requirements as mobile devices.

For devices located at a distance ≥ 20 cm, the test exclusion result must meet the criteria in Table 1, below, derived from the following formula:

$$300 \text{ MHz} - 1500 \text{ MHz: Limit (mW/cm}^2\text{)} = f(\text{MHz})/1500$$

Table 1:

Channel	MPE Distance (cm)	DUT Output Power (dBm)	DUT Antenna Gain (dBi) ¹	Power Density (mW/cm ²)	Limit (mW/cm ²)	Result
	(1)	(2)	(3)	(4)	(5)	
1	20	15.03	2.00	0.3210819	0.93	Compliant
3	20	14.94	2.00	0.3209634	0.93	Compliant
4	20	13.98	2.00	0.3198411	0.95	Compliant
6	20	13.84	2.00	0.3196972	0.95	Compliant

1. Requirements for a device used in a fixed location or a mobile device defined as a transmitting device designed to be used in other than fixed locations and to generally be used in such a way that a separation distance of at least 20 cm is normally maintained between the transmitter's radiating structure(s) and the body of the user or nearby persons.
2. Section 7.3 of this test report.
3. Data supplied by the client. Part number M484261300.
4. Peak power density is calculated from peak ERP measurement and antenna gain.
5. Reference CFR 1.1310, Table 1: Limits for Maximum Permissible Exposure (MPE), Section (B): Limits for General Population/Uncontrolled Exposure.

Test Number: 134-17R1

Issue Date: 5/4/2017

8. Test Setup Photographs

8.1 Radiated Field Strength, Harmonics and Spurious Emissions >1 GHz, Front View



8. Test Setup Photographs

8.2 Radiated Field Strength, Harmonics and Spurious Emissions >1 GHz, Rear View



Test Number: 134-17R1

Issue Date: 5/4/2017

8. Test Setup Photographs

8.3. Spurious Emissions <1 GHz, Front View



8. Test Setup Photographs

8.4. Spurious Emissions, Rear View (10 kHz to 30 MHz)



8. Test Setup Photographs

8.5. Spurious Emissions, Rear View (30 MHz to 1 GHz)



8. Test Setup Photographs

8.6. Conducted Emissions, Front View



Test Number: 134-17R1

Issue Date: 5/4/2017

8. Test Setup Photographs

8.7. Conducted Emissions, Rear View



8. Test Setup Photographs

8.8. ERP Measurement - General

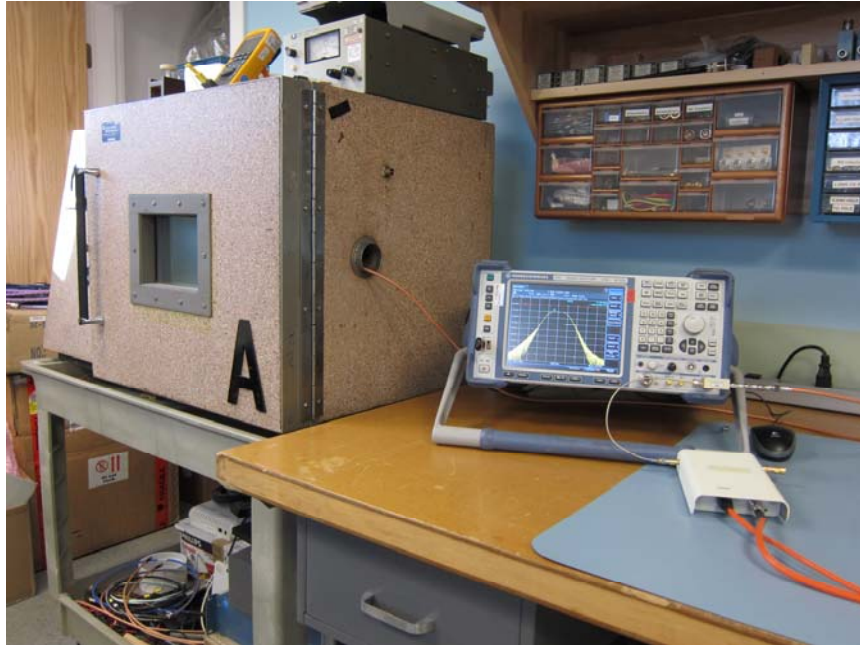

8.9. ERP Measurement - Close-up of Setup

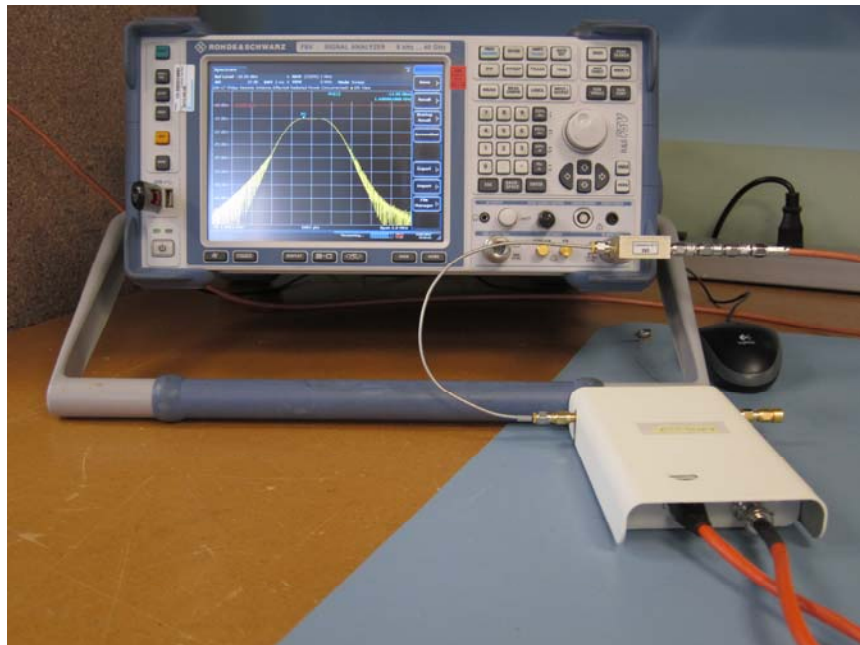

Test Number: 134-17R1

Issue Date: 5/4/2017

8. Test Setup Photographs

8.10. ERP Measurement – Remote Equipment



8. Test Setup Photographs

8.11. Frequency Stability Measurements – Host Equipment

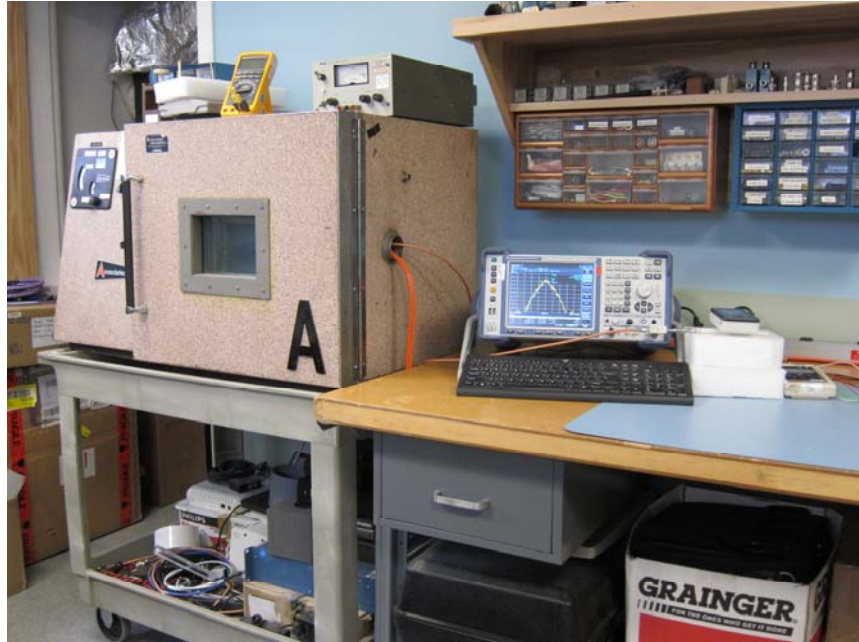

Test Number: 134-17R1

Issue Date: 5/4/2017

8. Test Setup Photographs

8.12. Frequency Stability Measurements – Device Under Test



9. Test Site Description

Compliance Worldwide is located at 357 Main Street in Sandown, New Hampshire. The test sites at Compliance Worldwide are used for conducted and radiated emissions testing in accordance with the Federal Communications Commission (FCC) and Industry Canada standards. Through our American Association for Laboratory Accreditation (A2LA) ISO Guide 17025:2005 Accreditation our test sites are designated with the FCC (designation number **US1091**), Industry Canada (file number **IC 3023A-1**) and VCCI (Member number 3168) under registration number A-0208.

Compliance Worldwide is also designated as a Phase 1 CAB under APEC-MRA (US0132) for Australia/New Zealand AS/NZS CISPR 22, Chinese-Taipei (Taiwan) BSMI CNS 13438 and Korea (RRA) KN 11, KN 13, KN 14-1, KN 22, KN 32, KN 61000-6-3, KN 61000-6-4.

The radiated emissions test site is a 3 and 10 meter enclosed open area test site (OATS). Personnel, support equipment and test equipment are located in the basement beneath the OATS ground plane.

The conducted emissions site is part of a 16' x 20' x 12' ferrite tile chamber and uses one of the walls for the vertical ground plane required by EN 55022. A second conducted emissions site is also located in the basement of the OATS site with a 2.3 x 2.5 meter ground plane and a 2.4 x 2.4 meter vertical wall.

Both sites are designed to test products or systems 1.5 meters W x 1.5 meters L x 2.0 meters H, floor standing or table top.