

**COMPLIANCE WORLDWIDE INC.
TEST REPORT 311-13**

**In Accordance with the Requirements of
Federal Communications Commission
CFR 47 Part 95, Subpart H
Wireless Medical Telemetry Devices
In the bands 1395-1400 and 1427-1432 MHz**

Issued to

**Philips Medical Systems
3000 Minuteman Drive
Andover, MA 01810
978-659-2800**

for the

ITS4843C

**Philips Telemetry System
IntelliVue Access Point
ITS4846A 1.4 GHz Remote Antenna**

FCC ID: PQC-4843C

Report Issued on June 5, 2013

Tested by



Brian F. Breault

Reviewed by



Larry K. Stillings

This test report shall not be reproduced, except in full, without written permission from Compliance Worldwide, Inc.

Table of Contents

1. Scope.....	3
2. Product Details.....	3
2.1. Manufacturer	3
2.2. Model Number	3
2.3. Serial Number.....	3
2.4. Description.....	3
2.5. Power Source	3
2.6. EMC Modifications.....	3
3. Product Configuration	3
3.1. Operational Characteristics & Software.....	3
3.2. EUT Hardware.....	3
3.3. EUT Cables/Transducers	3
3.4. Support Equipment.....	4
3.5. Support Equipment Cables/Transducers.....	4
3.6. Miscellaneous.....	4
3.7. Block Diagram	5
4. Measurements Parameters.....	6
4.1. Measurement Equipment Used to Perform Test	6
4.2. Measurement & Equipment Setup.....	6
4.3. Test Procedure	7
4.4. Measurement Uncertainty	7
5. Choice of Equipment for Test Suits	7
5.1. Choice of Model.....	7
5.2. Presentation	7
5.3. Choice of Operating Frequencies	7
6. Measurement Summary.....	8
7. Measurement Data	9
7.1. Radiated Field Strength of Fundamental.....	9
7.2. Combined Radiated Field Strength of Harmonics	12
7.3. Occupied Bandwidth.....	13
7.4. Band Edge.....	15
7.5. Spurious Radiated Emissions.....	17
7.6. Frequency Stability	25
7.7. Public Exposure to Radio Frequency Energy Levels	26
8. Test Site Description.....	27

1. Scope

This test report certifies that the Philips IntelliVue ITS4846A 1.4 GHz Remote Antenna, as tested, meets the Federal Communications Commission CFR 47, PART 95 requirement. The scope of this test report is limited to the test sample provided by the client, only in as much as that sample represents other production units. If any significant changes are made to the unit, the changes shall be evaluated and a retest may be required.

2. Product Details

- 2.1 Manufacturer:** Philips Medical Systems
- 2.2 Model Number:** 865052
- 2.3 Serial Number:** RO83323241
- 2.4 Description of EUT:** The ITS4846A 1.4 GHz Remote Antenna is connected to the IntelliVue Access Point which is incorporated into the Philips ITS4840A 1.4 GHz Telemetry system infrastructure.
Operating Frequencies: 1395.9, 1397.5, 1399.1, 1427.9, 1429.5, 1431.1 MHz.
- 2.5 Power Source:** DC 48 volts – From Power Over Ethernet switch.
- 2.6 EMC Modifications:** None

3. Product Configuration

3.1. Operational Characteristics & Software

The ITS4846A 1.4 GHz Remote Antenna is connected to the ITS4843A IntelliVue Access Point. The ITS4843A is connected to the M3185A Philips Clinical Network which shall be outside the field of test. The patient information will be displayed on a Philips M3150A IntelliVue Information Center which shall also be outside the field of test along with the TRx4841A 1.4 GHz Telemetry Transceiver-Patient Worn Device.

3.2. EUT Hardware

Blk Diag #	Manufactr	Model/Part # / Options	Serial Number	Input Voltage	Frq (Hz)	Description/Function
1*	Philips	989803171211 ITS4843C	US2082221	48 V	DC	Philips Telemetry II Cluster Access Point 1.4 GHz
1A*	Philips	865052/ITS4846A	RO83323241	48 V	DC	1.4 GHz AP remote antenna
1B*	Philips	865052/ITS4846A	RO83323219	48 V	DC	1.4 GHz AP remote antenna

* Only one unit was tested for this evaluation.

3.3. EUT Cables/Transducers

Blk Diag Ltr	Manufacturer	Model/Part #	Length (m)	Shield Y/N	Description/Function
A	Philips	NA	10	N	Category 5 UTP LAN cable, quantity 3
D	Philips	NA	10	Y/N	Coaxial/UTP combination cable

3. Product Configuration (continued)

3.4. Support Equipment

Blk Diag #	Manufactr	Model/Part # Options	Serial Number	Input Voltage	Input Frq.	Description/Function
2	Philips	865350	US11600708	3.7 VDC		IntelliVue 1.4 GHz Patient Worn Monitor
3	Philips	866212	SG31515280	100-240	50-60	IntelliVue Synchronization Box
4	Cisco	W-C2960PC-S	FCG1602V3V2	100-240	50-60	PoE/LAN switch
5	Philips	ITS3171A	35200236	100-240	50-60	Access Point Controller
6	Tripplite	SMART500RT1U	NA	120	60	Uninterruptible power supply
7	Philips	M3154B	2UA6261RQS	100-240	50-60	IntelliVue Information CenterS
8	Philips	190P6EB/27	Bz000534113115	100-240	50-60	Philips IntelliVue Information Center

3.5. Support Equipment Cables/Transducers

Blk Diag Ltr	Manufactr	Model/Part #	Length (m)	Shield Y/N	Description/Function
A	Philips	989803172051	2	N	ECG + SpO2 leadset
B	N/A	NA	Various	N	Category 5 UTP LAN cables
C	N/A	NA	2	N	AC Power cords

3.6. Miscellaneous (e.g., consumables, test fixtures, etc.):

Blk Diag Ltr	Manufactr	Model/Part #	Qty	Description/Function
NA	Duracell	AA batteries	3	For the IntelliVue 1.4 GHz Patient Worn Monitor

3. Product Configuration (continued)

3.7. Block Diagram

FCC Test System

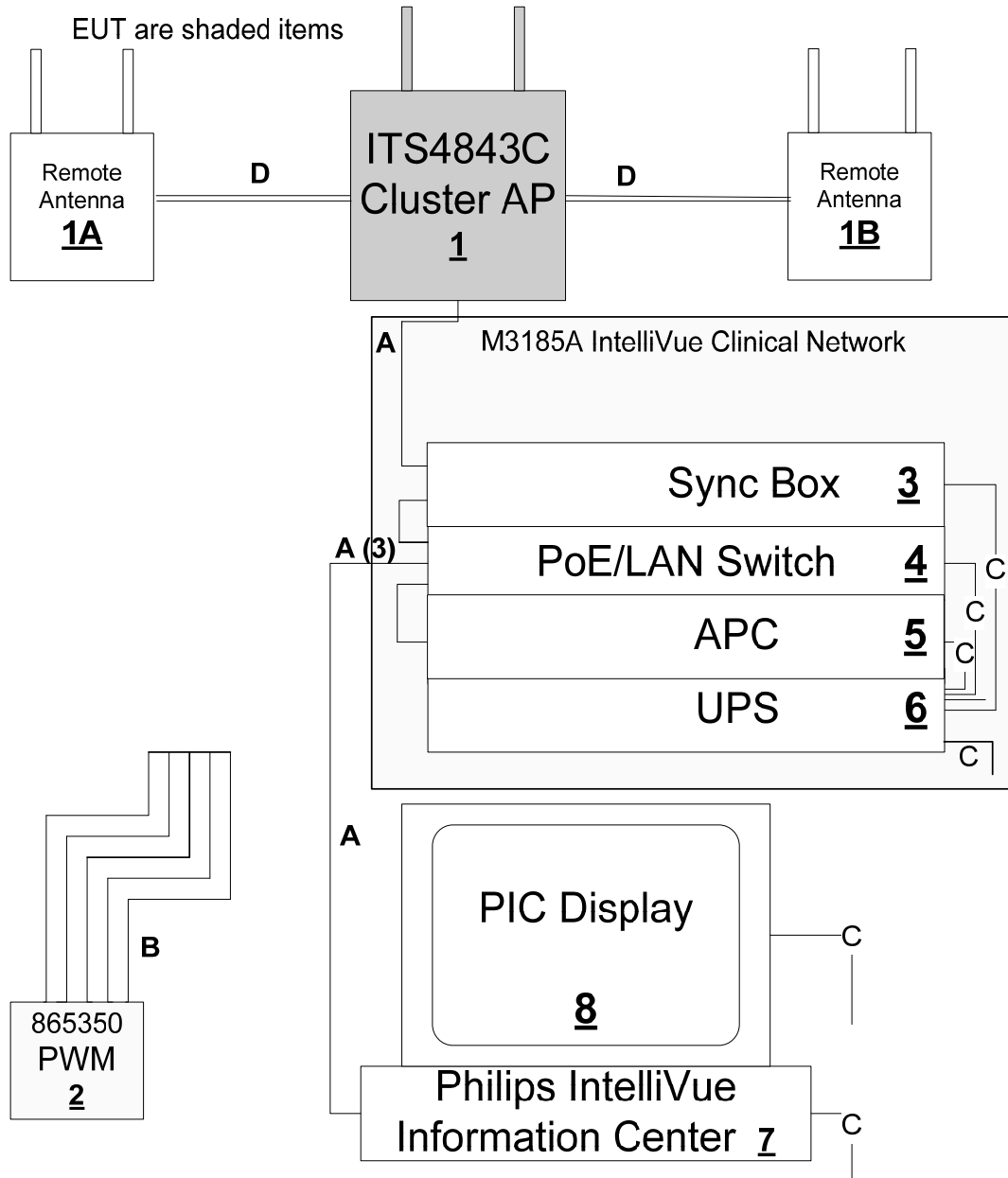

4. Measurements Parameters

4.1. Measurement Equipment Used to Perform Test

Device	Manufacturer	Model No.	Serial No.	Cal Due
EMI Test Receiver, 9kHz - 7GHz	Rohde & Schwarz	ESR7	101156	4/4/2015
Spectrum Analyzer 20 Hz – 40 GHz	Rohde & Schwarz	FSV40	100899	6/5/2015
Spectrum Analyzer 9 kHz – 26.5 GHz	Agilent Technologies	E7405A	MY45115430	5/11/2014
EMI Receiver	Hewlett Packard	8546A	3650A00360	6/13/2014
Microwave Preamplifier	Hewlett Packard	83050A	3331A00404	6/6/2013
Loop Antenna	EMCO	6512	9309-1139	8/28/2014
Bilog Antenna	Com-Power	AC-220	25509	8/20/2013
Horn Antenna, 1 GHz – 18 GHz	ETS-Lindgren	3117	00143292	1/14/2015
Horn Antenna, 18 GHz – 40 GHz	Com-Power	AH-840	3075	8/27/2014
LISN 50 Ω 50 μH, 9 kHz to 30 MHz	EMCO	3825/2	9109-1860	7/2/2013
Power Supply	Hewlett Packard	6296A	7M0599	N/A
Digital Barometer	Control Company	4195	ID236	2/25/2015
Temperature Chamber	Associated Research	E-0029	N/A	N/A

4.2. Measurement & Equipment Setup

Test Dates: May 28 - Jun 3, 2013
 Test Engineer: Brian Breault
 Normal Site Temperature (15 - 35°C): 24.0
 Relative Humidity (20 -75%RH): 33%
 Frequency Range: 30 MHz to 16 GHz
 Measurement Distance: 3 Meters
 EMI Receiver IF Bandwidth: 120 kHz - 30 MHz to 1 GHz
 1 MHz - Above 1 GHz
 EMI Receiver Avg Bandwidth: 300 kHz - 30 MHz to 1 GHz
 3 MHz - Above 1 GHz
 Detector Function: Peak, QP - 30 MHz to 1 GHz
 Peak, Avg - Above 1 GHz
 Unless otherwise specified.

4. Measurements Parameters (continued)

4.3. Test Procedure

All references to CFR 47 PART 95, Subpart H - Wireless Medical Telemetry Service (WMTS) - refer to the 10-1-12 edition.

The test methods used to generate the data in this test report is in accordance with ANSI C63.4: 2009, American National Standard for Methods of Measurement of Radio-Noise Emissions from Low-Voltage Electrical and Electronic Equipment in the Range of 9 kHz to 40 GHz

4.4. Measurement Uncertainty

The following uncertainties are expressed for an expansion/coverage factor of K=2.

RF Frequency	$\pm 1 \times 10^{-8}$
Radiated Emission of Transmitter	± 4.55 dB
Radiated Emission of Receiver	± 4.55 dB
Temperature	$\pm 0.91^{\circ}$ C
Humidity	$\pm 5\%$

5. Choice of Equipment for Test Suits

5.1 Choice of Model

This test report is based on the test samples supplied by the manufacturer and are reported by the manufacturer to be equivalent to the production units.

5.2 Presentation

This test sample was tested complete with all required ancillary equipment. Refer to Section 3 of this report for product equipment configuration.

5.3 Choice of Operating Frequencies

The choice of operating frequencies selected for the testing outlined in this report was based on the lowest and highest operating frequencies in each of the two bands utilized by the device under test. The frequencies selected were 1395.9 MHz, 1399.1 MHz, 1427.9 MHz and 1431.1 MHz.

6. Measurement Summary

Transmitter Test Requirement	FCC Requirement	Test Report Section	Result	Comment
Product Labeling	95.1109(b)	N/A	N/A	See exhibits FCC label sample and label location.
Emission Type	95.1115(c)	N/A	N/A	Transmits Data and ECG Waveform
Frequency Stability	95.1115(e)	N/A	N/A	Data Provided By Philips Medical
RF Safety	95.1125	N/A	N/A	Statement and Technical Basis
Radiated Field Strength of Fundamental	95.1115(a)(2)	7.1	Compliant	
Radiated Field Strength of Harmonics	95.1115(b)(2)	7.2	Compliant	
Occupied Bandwidth	95.1111(a)(2)	7.3	Compliant	
Band Edge Measurements	95.1115(b)(2)	7.4	Compliant	
Spurious Radiated Emissions	95.1115(b)	7.5	Compliant	
Frequency Stability	95.1115 (e)	7.6	Compliant	
Public Exposure to Radio Frequency Energy Levels	15.247(i)	7.7	Compliant	

7. Measurement Data

7.1. Radiated Field Strength of Fundamental

Requirement: In the 1395–1400 MHz and 1427–1429.5 MHz bands, the maximum allowable field strength is 740 mV/m (117.4 dB μ V/m), as measured at a distance of 3 meters, using measuring equipment with an averaging detector and a 1 MHz measurement bandwidth (§ 95.1115, (a)(2)).

When average radiated emission measurements are specified in this part, there also is a limit on the peak level of the radio frequency emissions. Unless otherwise specified, the limit on peak radio frequency emissions is 20 dB above the maximum permitted average emission limit applicable to the equipment under test.

Channel	Freq (MHz)	Field Strength (dB μ V/m)		Limit (dB μ V/m)		Peak Margin (dB)	Average Margin (dB)	Result
		Peak	Average	Peak	Average			
1	1395.9	111.87	82.66	137.4	117.4	-25.53	-34.74	Compliant
3	1399.1	110.78	82.05	137.4	117.4	-26.62	-35.35	Compliant
4	1427.9	111.09	80.66	137.4	117.4	-26.31	-36.74	Compliant
6	1431.1	111.38	80.55	137.4	117.4	-26.02	-36.85	Compliant

7.1.1. Channel 1

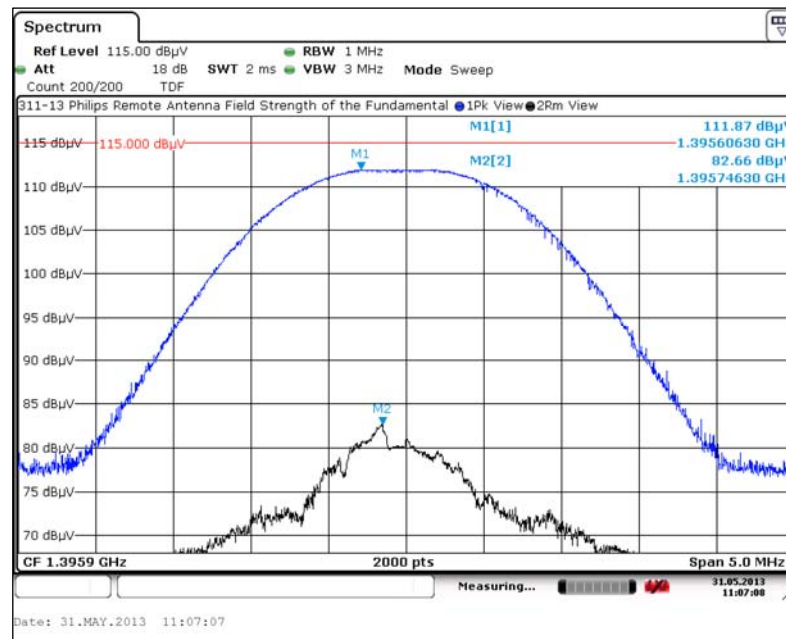

7. Measurement Data (continued)

7.1. Radiated Field Strength of Fundamental (continued)

7.1.1. Channel 3

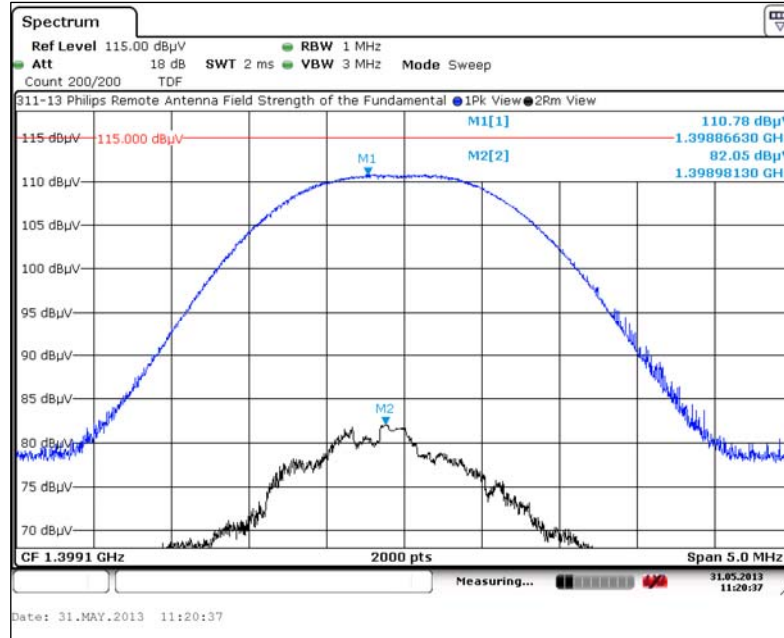

7.1.2. Channel 4

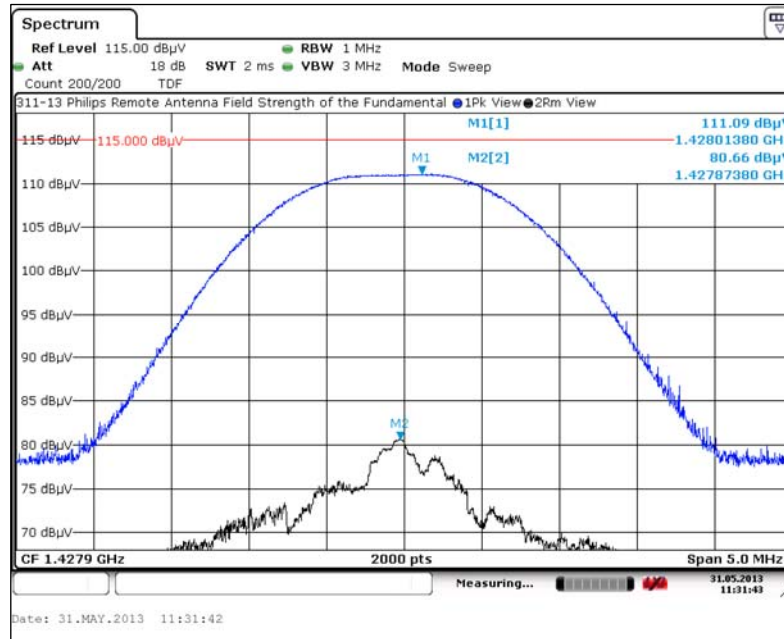

7. Measurement Data (continued)

7.1. Radiated Field Strength of Fundamental (continued)

7.1.1. Channel 6

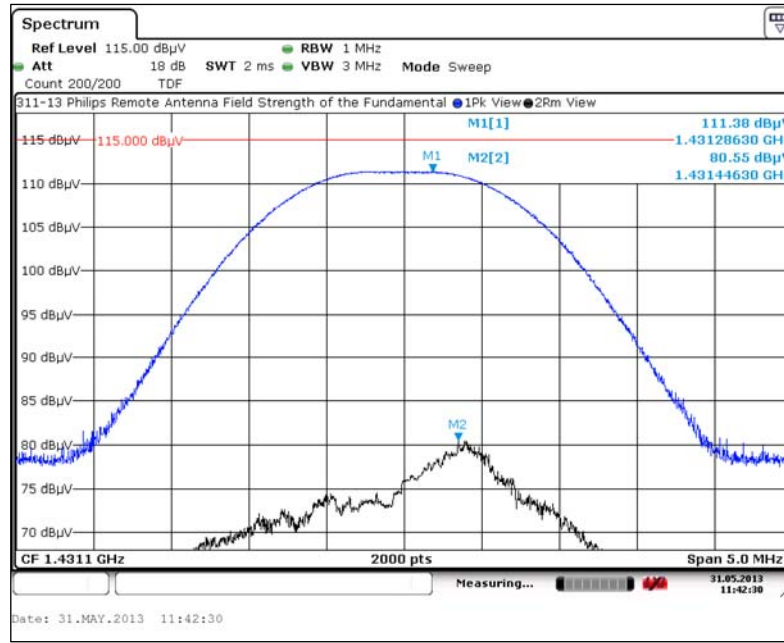

7. Measurement Data (continued)

7.2. Combined Radiated Field Strength of Harmonics

Requirement: Out-of-band emissions above 960 MHz are limited to 500 microvolts/meter as measured at a distance of 3 meters, using measuring equipment with an averaging detector and a 1 MHz (§ 95.1115, (b)(2)).

Results: Compliant.

Frequency (MHz)	Field Strength (dBµV/m)		Limit (dBµV/m)		Margin (dB)		Antenna Polarity (H/V)
	Peak	Avg	Peak	Avg	Peak	Avg	
2791.8	52.68	35.47	74	54	-21.32	-18.53	V
2798.2	51.43	34.80	74	54	-22.57	-19.20	V
2855.8	49.35	35.42	74	54	-24.65	-18.58	V
2862.2	50.98	35.45	74	54	-23.02	-18.55	H
4187.7	49.16	36.11	74	54	-24.84	-17.89	H
4197.3	47.94	36.22	74	54	-26.06	-17.78	H
4283.7	48.70	36.65	74	54	-25.30	-17.35	H
4293.3	48.83	37.00	74	54	-25.17	-17.00	V
5583.6	52.15	38.68	74	54	-21.85	-15.32	H
5596.4	50.91	38.63	74	54	-23.09	-15.37	V
5711.6	50.72	38.12	74	54	-23.28	-15.88	H
5724.4	50.45	38.58	74	54	-23.55	-15.42	V
6979.5	53.08	40.75	74	54	-20.92	-13.25	H
6995.5	51.30	39.33	74	54	-22.70	-14.67	H
7139.5	52.53	40.14	74	54	-21.47	-13.86	H
7155.5	53.12	39.98	74	54	-20.88	-14.02	V
8375.4	53.47	40.44	74	54	-20.53	-13.56	V
8394.6	52.38	40.45	74	54	-21.62	-13.55	V
8567.4	53.62	41.00	74	54	-20.38	-13.00	H
8586.6	53.68	41.29	74	54	-20.32	-12.71	H
9771.3	54.17	42.25	74	54	-19.83	-11.75	V
9793.7	53.90	41.92	74	54	-20.10	-12.08	H
9995.3	54.78	42.40	74	54	-19.22	-11.60	H
10017.7	54.26	42.78	74	54	-19.74	-11.22	H
11167.2	56.17	43.56	74	54	-17.83	-10.44	V
11192.8	55.30	43.62	74	54	-18.70	-10.38	V
11423.2	55.21	48.54	74	54	-18.79	-5.46	H
11448.8	55.68	43.67	74	54	-18.32	-10.33	H
12563.1	58.33	45.07	74	54	-15.67	-8.93	H
12591.9	56.84	44.94	74	54	-17.16	-9.06	H
12851.1	57.78	45.59	74	54	-16.22	-8.41	H
12879.9	58.04	45.50	74	54	-15.96	-8.50	H
13959.0	59.45	46.61	74	54	-14.55	-7.39	H
13991.0	58.65	46.30	74	54	-15.35	-7.70	H
14279.0	59.60	47.34	74	54	-14.40	-6.66	H
14311.0	59.78	47.34	74	54	-14.22	-6.66	H

7. Measurement Data (continued)

7.3. Occupied Bandwidth

Requirement: The bandwidth is measured at an amplitude level reduced from the reference level by a specified ratio. The reference level is the level of the highest amplitude signal observed from the transmitter at either the fundamental frequency or the first-order modulation products in all typical modes of operation, including the unmodulated carrier, even if atypical. Once the reference level is established, the equipment is conditioned with typical modulating signals to produce the worst-case (i.e., the widest) bandwidth. If no bandwidth requirement is specified by the procuring or regulatory agency, measure the bandwidth at -26 dB with respect to the reference level.

Result: Compliant

Channel	Freq (MHz)	Bandwidth (MHz)
1	1395.9	1.410
3	1399.1	1.425
4	1427.9	1.398
6	1431.1	1.378

7.3.1. Channel 1, 1395.9 MHz

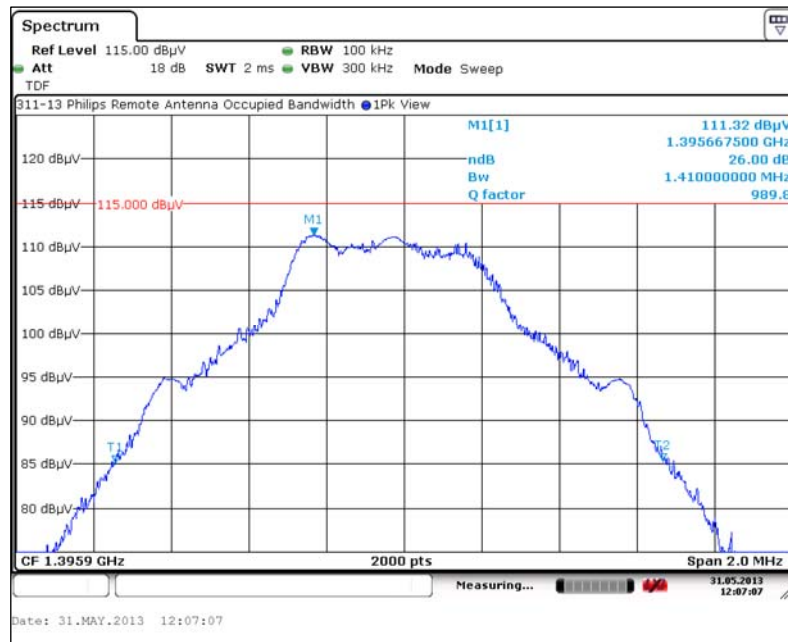

7. Measurement Data (continued)

7.3. Occupied Bandwidth (continued)

7.3.2. Channel 3, 1399.1 MHz

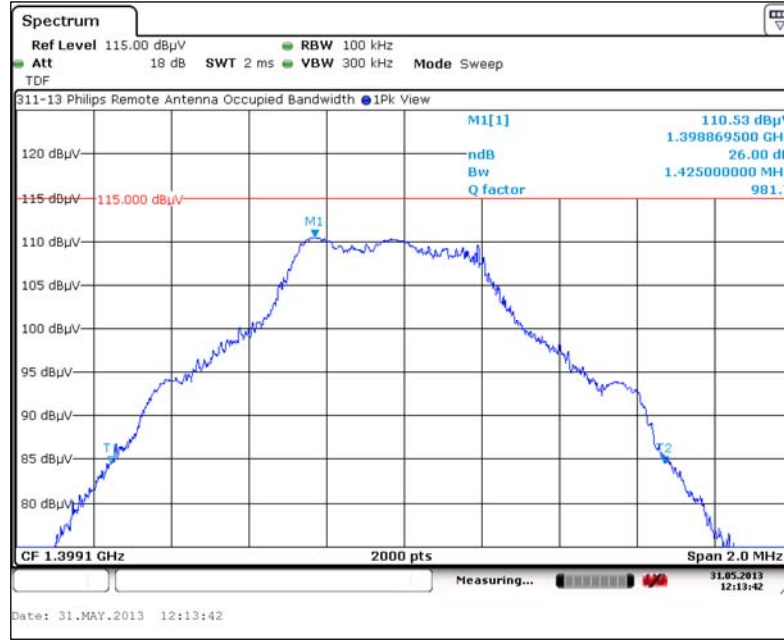

7.3.3. Channel 4, 1427.9 MHz

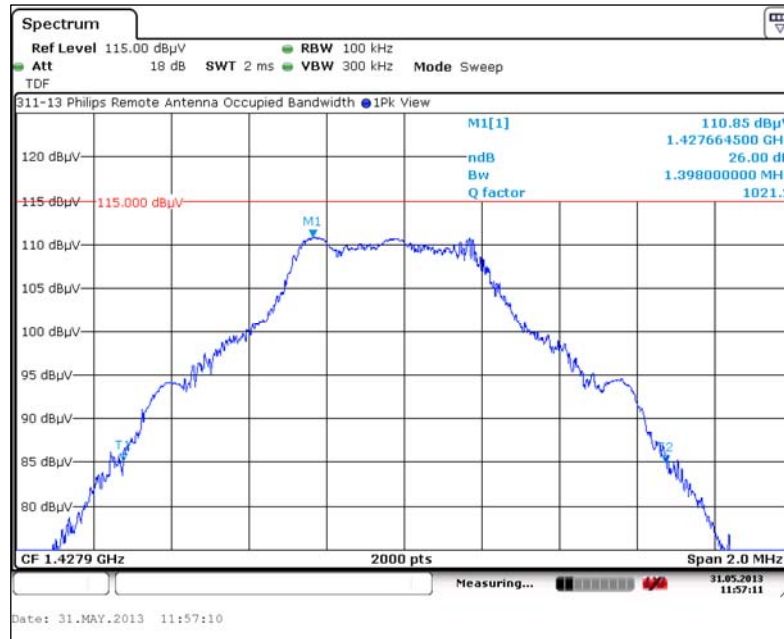

7. Measurement Data (continued)

7.3. Occupied Bandwidth (continued)

7.3.4. Channel 6, 1431.1 MHz

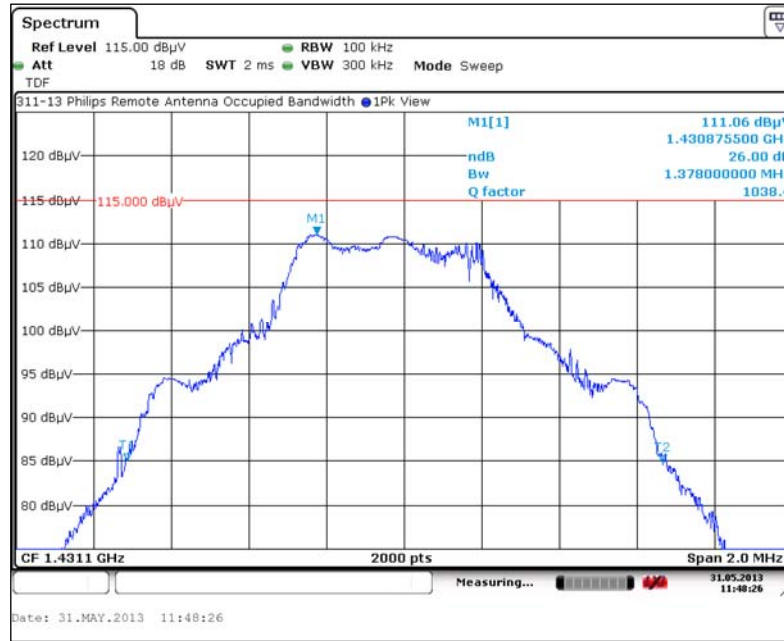

7.4. Band Edge

Requirement: Out-of-band emissions above 960 MHz are limited to 500 microvolts per meter (54 dBµV/m) as measured at a distance of 3 meters, using measuring equipment with an averaging detector and a 1 MHz measurement bandwidth.

Test Note: The procedure detailed in the FCC Office of Engineering and Technology (FCC OET) Publication Number 913591: Measurement of Radiated Emissions at the Edge of the Band for a Part 15 RF Device was used in determining the following values.

7.4.1. Lower Band Edge (1395–1400)

Channel 1 (MHz)	Field Strength (dBµV/m)		Band Edge Frequency (MHz)	Field Strength (dBµV/m)		Average Limit (dBµV/m)	Margin (dB)	Result
	Peak	Average		Peak	Average			
1395.9	111.9	82.7	1395	69.78	40.57	54	-13.43	Compliant

Worst Case Out of Band (1395–1400)

Channel 1 (MHz)	Field Strength (dBµV/m)		Out of Band Frequency (MHz)	Field Strength (dBµV/m)		Average Limit (dBµV/m)	Margin (dB)	Result
	Peak	Average		Peak	Average			
1395.9	111.9	82.7	1394.7301	72.80	43.59	54.00	-10.41	Compliant

7. Measurement Data (continued)

7.4. Band Edge (continued)

7.4.2. Upper Band Edge (1395–1400)

Channel 3 (MHz)	Field Strength (dBµV/m)		Band Edge Frequency (MHz)	Field Strength (dBµV/m)		Average Limit (dBµV/m)	Margin (dB)	Result
	Peak	Average		Peak	Average			
1399.1	110.8	82.1	1400	63.87	35.14	54.00	-18.86	Compliant

Worst Case Out of Band (1395–1400)

Channel 3 (MHz)	Field Strength (dBµV/m)		Out of Band Frequency (MHz)	Field Strength (dBµV/m)		Average Limit (dBµV/m)	Margin (dB)	Result
	Peak	Average		Peak	Average			
1399.1	111.6	79.1	1397.9111	72.07	39.63	54	-14.37	Compliant

7.4.3. Lower Band Edge (1427–1429.5)

Channel 4 (MHz)	Field Strength (dBµV/m)		Band Edge Frequency (MHz)	Field Strength (dBµV/m)		Average Limit (dBµV/m)	Margin (dB)	Result
	Peak	Average		Peak	Average			
1427.9	111.1	80.7	1427	66.22	35.79	54.00	-18.21	Compliant

Worst Case Out of Band (1427–1429.5)

Channel 4 (MHz)	Field Strength (dBµV/m)		Band Edge Frequency (MHz)	Field Strength (dBµV/m)		Average Limit (dBµV/m)	Margin (dB)	Result
	Peak	Average		Peak	Average			
1427.9	111.1	80.7	1426.7441	71.94	41.51	54.00	-12.49	Compliant

7.4.4. Upper Band Edge (1427–1429.5)

Channel 6 (MHz)	Field Strength (dBµV/m)		Band Edge Frequency (MHz)	Field Strength (dBµV/m)		Average Limit (dBµV/m)	Margin (dB)	Result
	Peak	Average		Peak	Average			
1431.1	111.4	80.6	1432	63.37	32.54	54.00	-21.46	Compliant

Worst Case Out of Band (1427–1429.5)

Channel 6 (MHz)	Field Strength (dBµV/m)		Band Edge Frequency (MHz)	Field Strength (dBµV/m)		Average Limit (dBµV/m)	Margin (dB)	Result
	Peak	Average		Peak	Average			
1431.1	111.4	80.6	1432.1929	71.71	40.88	54.00	-13.12	Compliant

7. Measurement Data (continued)

7.5. Spurious Radiated Emissions

Regulatory Limit: FCC Part 209, Class B, Quasi-Peak

Frequency Range (MHz)	Distance (Meters)	Limit (dB μ V/m) ¹
0.009 to 0.490	3	128.5 to 93.8
0.490 to 1.705	3	73.8 to 63.0
1.705 to 30	3	69.5
30 to 88	3	40.0
88 to 216	3	43.5
216 to 960	3	46.0
>960	3	54.0

¹ Measurements in the 9 to 90 kHz, 110 to 490 kHz and above 1000 MHz ranges employ an average detector. Otherwise a quasi-peak detector is used.

Test Procedure: Test measurements were made in accordance with ANSI C63.4-2009, Standard Methods of Measurement of Radio Noise Emissions from Low-Voltage Electrical and Electronics Equipment in the Range of 9 kHz to 40 GHz.

Test Note: The ITS4843C IntelliVue Access Point and ITS4846A 1.4 GHz Remote Antenna were measured together below 1 GHz. Above 1 GHz the two devices were measured separately to avoid mutual interference.

Test Results: The DUT is meets the FCC Part 15.209 requirements for radiated emissions.

7. Measurement Data (continued)

7.5. Spurious Radiated Emissions (continued)

7.5.1. 32 kHz to 150 kHz, Parallel Antenna

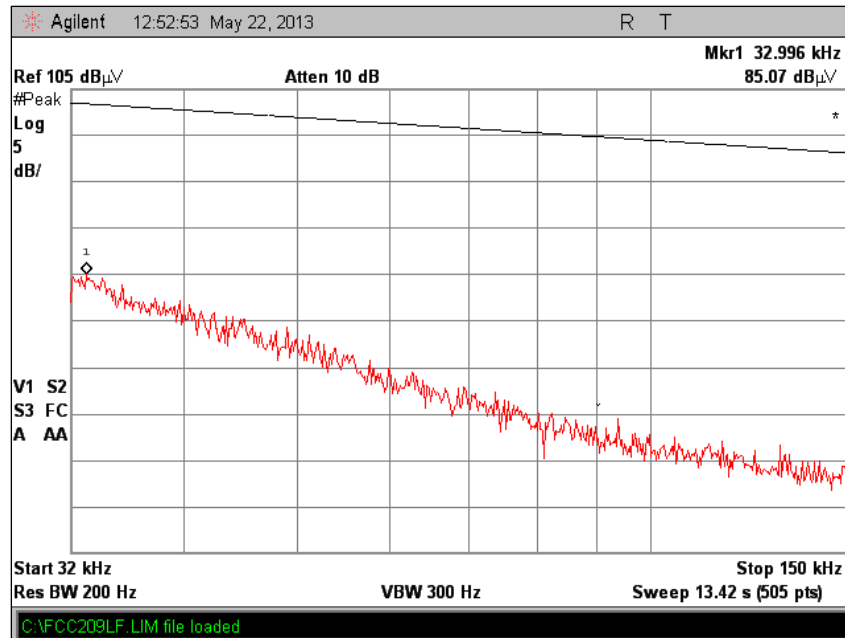

7.5.2. 32 kHz to 150 kHz, Perpendicular Antenna

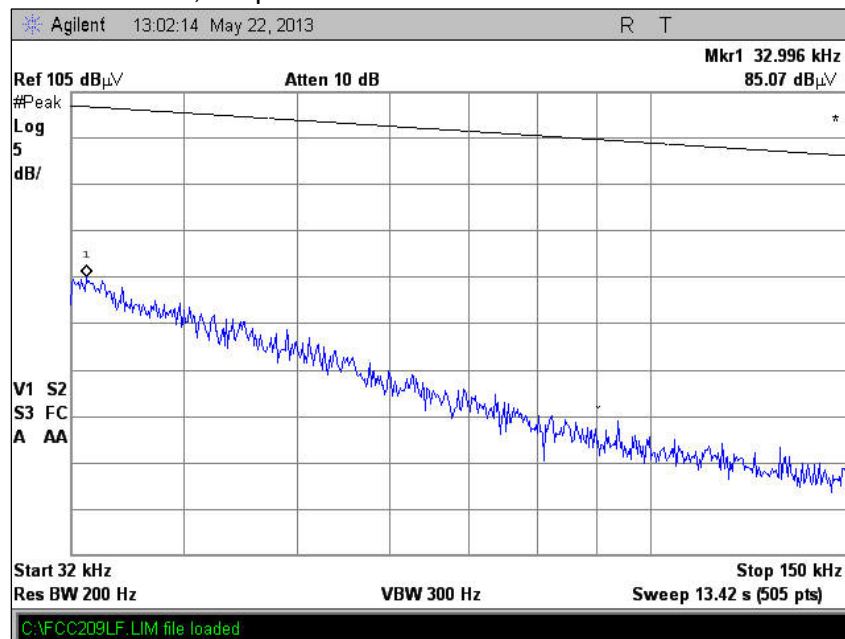

7. Measurement Data (continued)

7.5. Spurious Radiated Emissions (continued)

7.5.3. 150 kHz to 30 MHz, Parallel Antenna

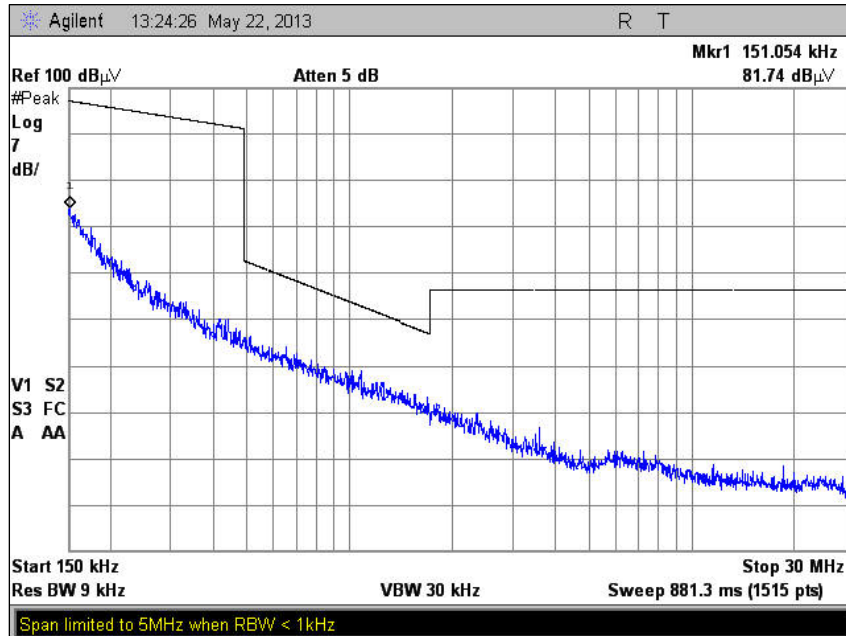

7.5.4. 150 kHz to 30 MHz, Perpendicular Antenna

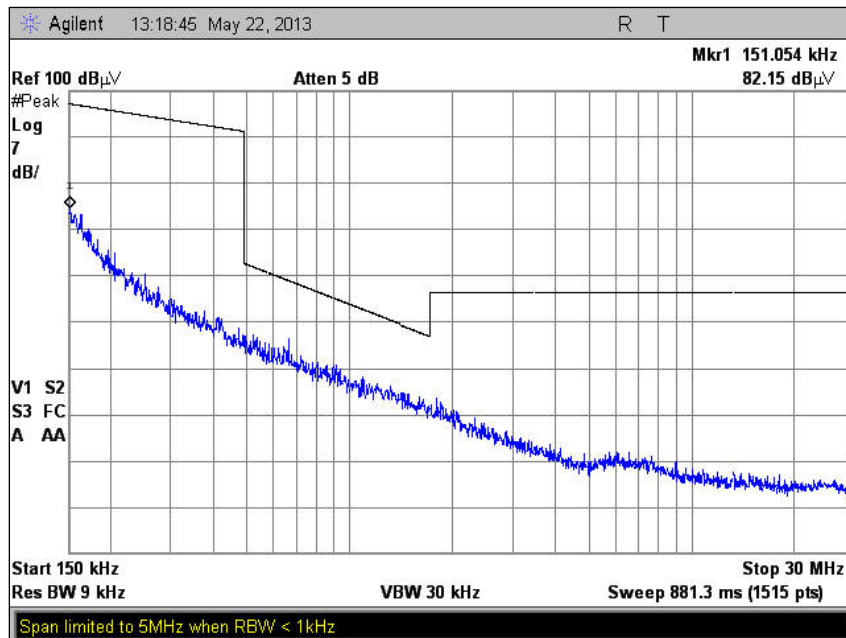

7. Measurement Data (continued)

7.5. Spurious Radiated Emissions (continued)

7.5.5. 30 MHz to 1 GHz, Horizontal Polarity

Test No.: 305-13, Radiated Emissions - Horizontal Polarity

FCC, Class B

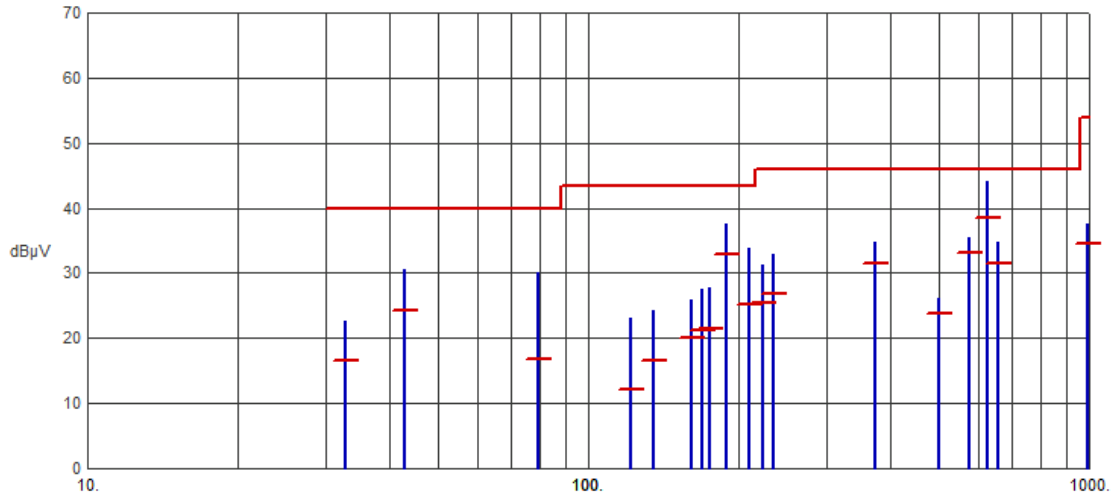

Frequency (MHz)	Pk Amp (dBµV/m)	QP Amp (dBµV/m)	QP Limit (dBµV/m)	Margin (dB)	Ant Ht (cm)	Table (Deg)	Comments
32.8058	22.67	16.58	40.00	-23.42	N/A	N/A	
42.9290	30.49	24.23	40.00	-15.77	N/A	N/A	
79.2704	30.02	16.82	40.00	-23.18	N/A	N/A	
121.6987	23.21	12.17	43.50	-31.33	N/A	N/A	
134.7517	24.27	16.64	43.50	-26.86	N/A	N/A	
160.9473	25.97	20.13	43.50	-23.37	N/A	N/A	
168.4753	27.65	21.29	43.50	-22.21	N/A	N/A	
174.7028	27.84	21.49	43.50	-22.01	N/A	N/A	
189.2585	37.68	32.91	43.50	-10.59	N/A	N/A	
209.0478	33.86	25.17	43.50	-18.33	N/A	N/A	
222.6000	31.28	25.33	46.00	-20.67	N/A	N/A	
234.1565	32.91	26.94	46.00	-19.06	N/A	N/A	
375.0051	34.70	31.39	46.00	-14.61	N/A	N/A	
499.9986	26.08	23.80	46.00	-22.20	N/A	N/A	
577.4981	35.57	33.07	46.00	-12.93	N/A	N/A	
625.0356	44.05	38.46	46.00	-7.54	N/A	N/A	
659.9941	34.83	31.54	46.00	-14.46	N/A	N/A	
990.0220	37.52	34.47	54.00	-19.53	N/A	N/A	

7. Measurement Data (continued)

7.5. Spurious Radiated Emissions (continued)

7.5.6. 30 MHz to 1 GHz, Vertical Polarity

Test No.: 305-13, Radiated Emissions - Vertical Polarity

FCC, Class B

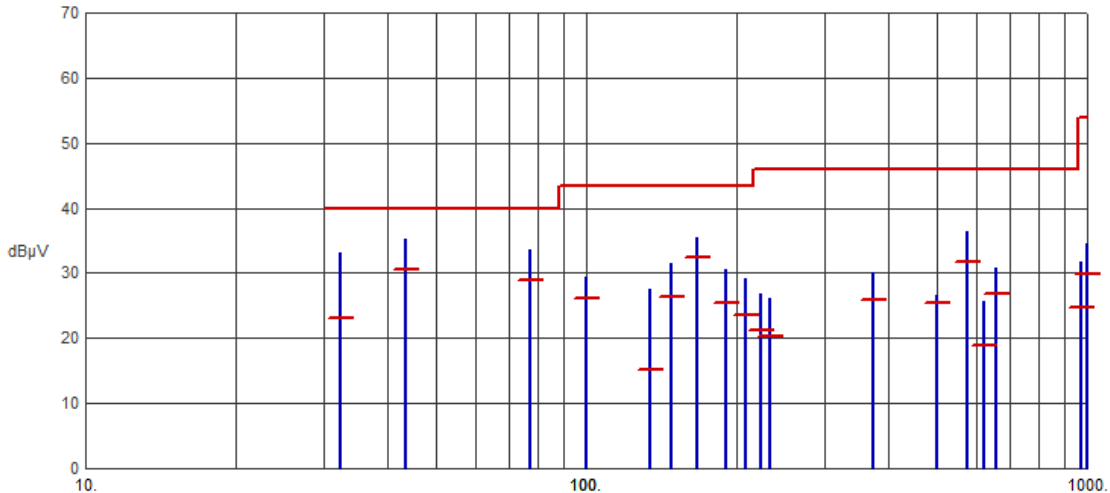

Frequency (MHz)	Pk Amp (dBµV/m)	QP Amp (dBµV/m)	QP Limit (dBµV/m)	Margin (dB)	Ant Ht (cm)	Table (Deg)	Comments
32.3745	33.12	23.16	40.00	-16.84	N/A	N/A	
43.4939	35.32	30.60	40.00	-9.40	N/A	N/A	
77.1835	33.60	28.82	40.00	-11.18	N/A	N/A	
100.1006	29.37	26.05	43.50	-17.45	N/A	N/A	
134.3846	27.62	15.09	43.50	-28.41	N/A	N/A	
148.0932	31.40	26.30	43.50	-17.20	N/A	N/A	
165.8815	35.41	32.47	43.50	-11.03	N/A	N/A	
189.5889	30.58	25.38	43.50	-18.12	N/A	N/A	
208.5359	29.18	23.64	43.50	-19.86	N/A	N/A	
223.0998	26.86	21.24	46.00	-24.76	N/A	N/A	
233.3306	26.15	20.34	46.00	-25.66	N/A	N/A	
374.9841	30.17	25.91	46.00	-20.09	N/A	N/A	
500.0345	26.67	25.44	46.00	-20.56	N/A	N/A	
577.4897	36.35	31.63	46.00	-14.37	N/A	N/A	
620.1205	25.56	18.92	46.00	-27.08	N/A	N/A	
659.9670	30.84	26.91	46.00	-19.09	N/A	N/A	
970.3653	31.71	24.78	54.00	-29.22	N/A	N/A	
1000.0000	34.51	29.95	54.00	-24.05	N/A	N/A	

7. Measurement Data (continued)

7.5. Spurious Radiated Emissions (continued)

7.5.7. 1 GHz to 5 GHz, Horizontal Polarity

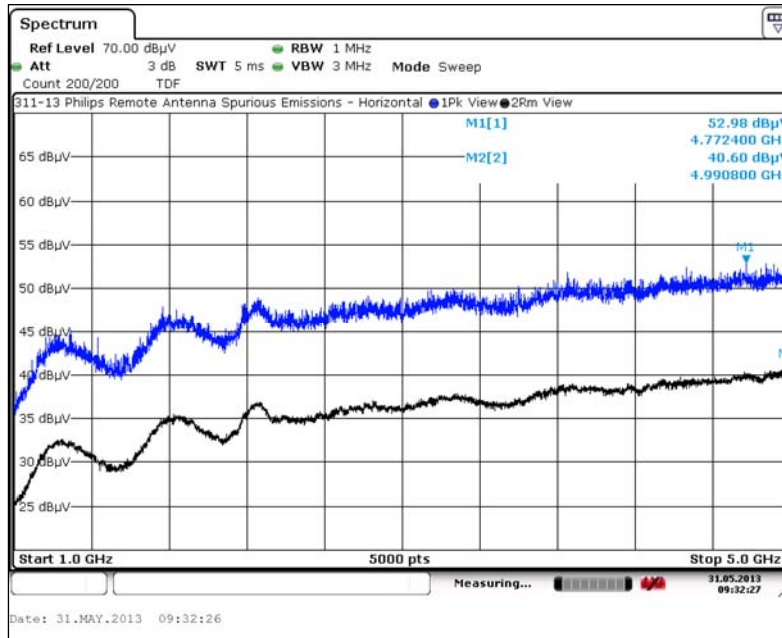

7.5.8. 1 GHz to 5 GHz, Vertical Polarity

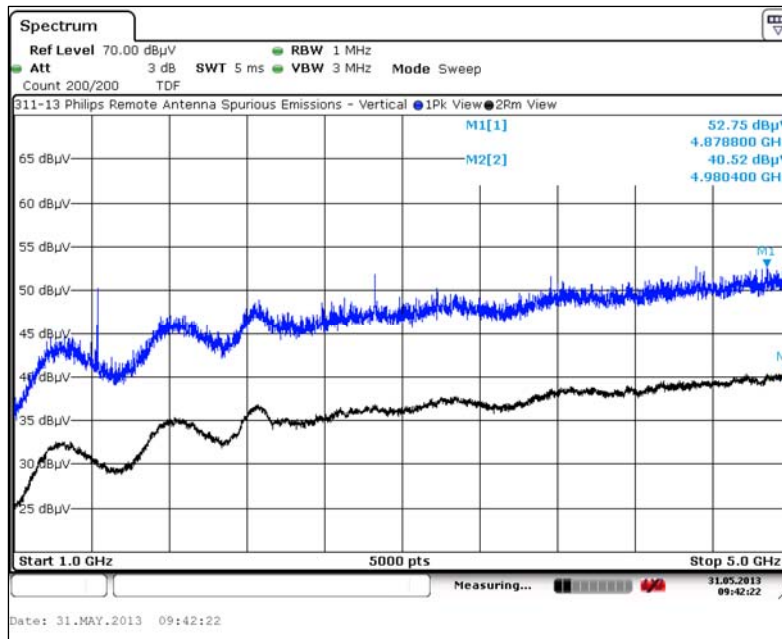

7. Measurement Data (continued)

7.5. Spurious Radiated Emissions (continued)

7.5.9. 5 GHz to 10 GHz, Horizontal Polarity

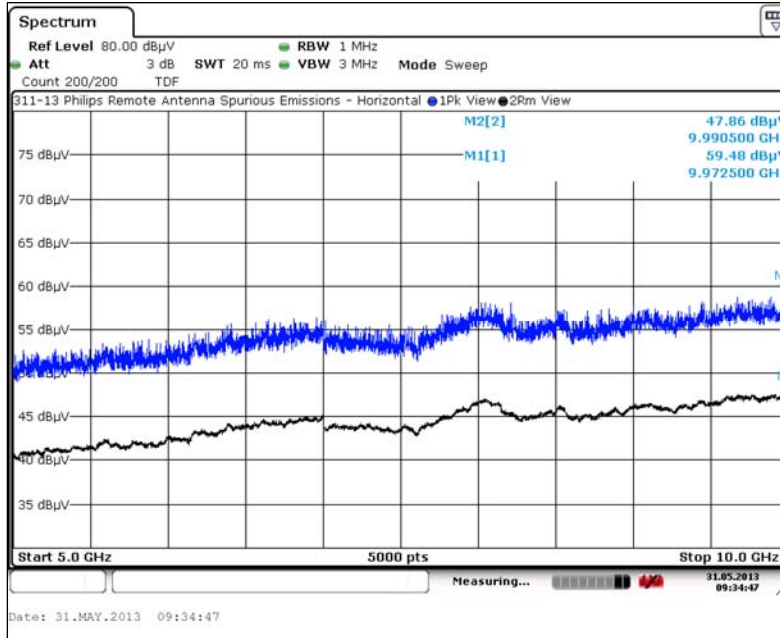

7.5.10. 5 GHz to 10 GHz, Vertical Polarity

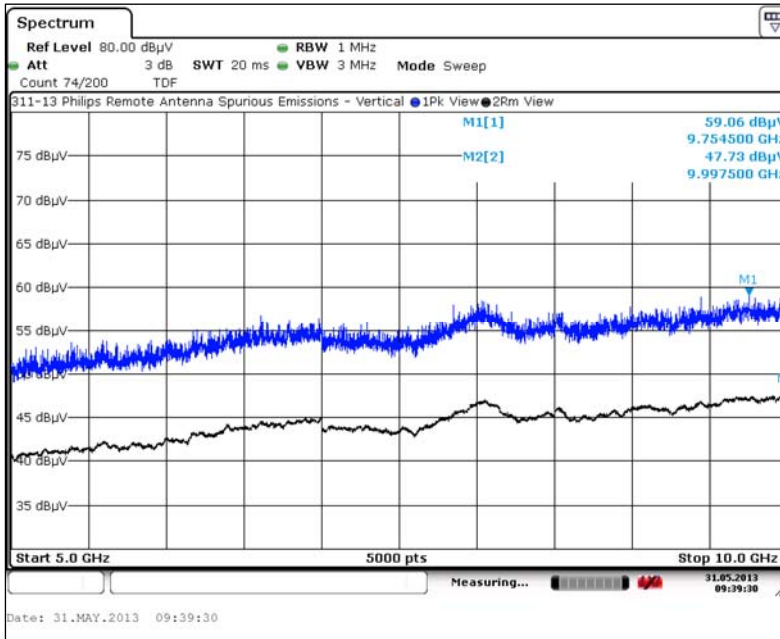

7. Measurement Data (continued)

7.5. Spurious Radiated Emissions (continued)

7.5.11. 10 GHz to 15 GHz, Horizontal Polarity

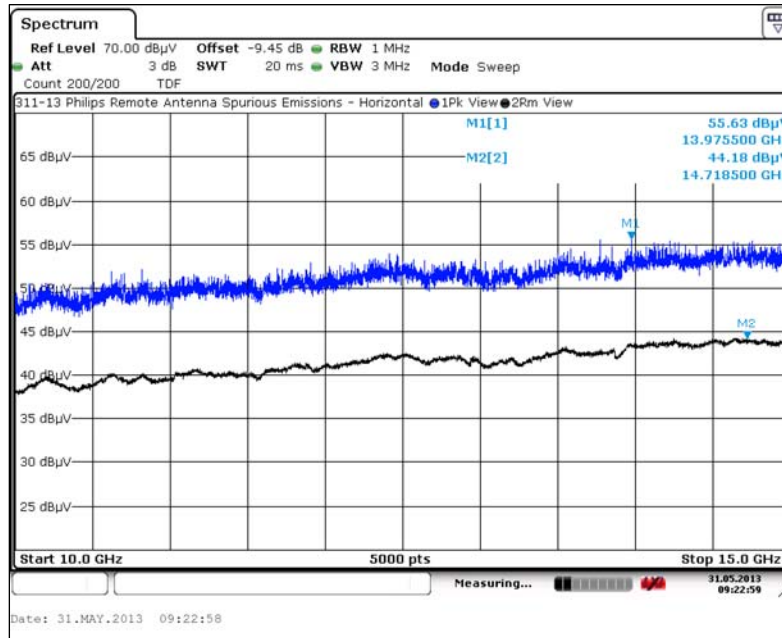

7.5.12. 10 GHz to 15 GHz, Vertical Polarity

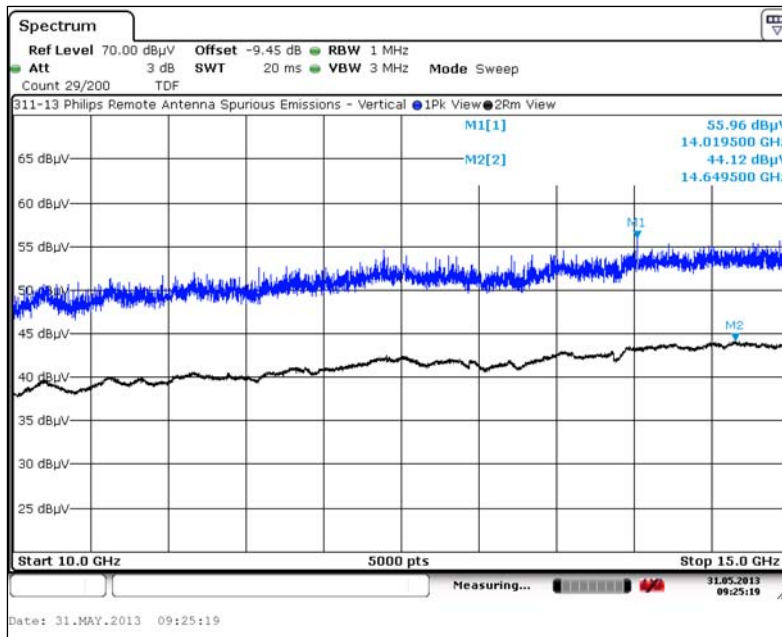

7. Measurement Data (continued)

7.6. Frequency Stability (FCC 95.1115 (e))

Requirement: Manufacturers of wireless medical telemetry devices are responsible for ensuring frequency stability such that an emission is maintained within the band of operation under all of the manufacturer's specified conditions.

Nominal Temperature : 26.4 °C
 Temperature Tolerance : Lower : 0 °C
 Upper : 55 °C
 Philips Medical requirement

Nominal Voltage : 48.0 Volts DC
 Voltage Tolerance : Lower : 37 Volts DC
 Upper : 57 Volts DC
 Per IEEE 802.3at Type 1 and Type 2 for Power over Ethernet voltage range at PD (Powered Device).

Measurement Results : The DUT remains well within the WMTS bands.

Channel	Assigned Freq. GHz	Temp	Voltage	Meas. Frequency MHz	Deviation		Result
		Deg. C	VDC		kHz	%	
1	1395.9	Nominal	Nominal	1395.8830	-17.00000	0.001218	N/A
		0	37	1395.8798	-20.2000	0.001447	Compliant
			57	1395.8916	-8.4000	0.000602	Compliant
		55	37	1395.8826	-17.4000	0.001247	Compliant
			57	1395.8794	-20.6000	0.001476	Compliant
		3	1399.1	Nominal	Nominal	1399.0872	-12.8000
0	37			1399.0808	-19.2000	0.001372	Compliant
	57			1399.0808	-19.2000	0.001372	Compliant
55	37			1399.0782	-21.8000	0.001558	Compliant
	57			1399.0797	-20.3000	0.001451	Compliant
4	1427.9			Nominal	Nominal	1427.9000	0.0000
		0	37	1427.8770	-23.0000	0.001611	Compliant
			57	1427.8790	-21.0000	0.001471	Compliant
		55	37	1427.8776	-22.4000	0.001569	Compliant
			57	1427.8798	-20.2000	0.001415	Compliant
		6	1431.1	Nominal	Nominal	1431.0840	-16.0000
0	37			1431.0762	-23.8000	0.001663	Compliant
	57			1431.0952	-4.8000	0.000335	Compliant
55	37			1431.0820	-18.0000	0.001258	Compliant
	57			1431.0886	-11.4000	0.000797	Compliant

7. Measurement Data (continued)

7.7. Public Exposure to Radio Frequency Energy Levels (15.247(i) (1.1307 (b)(1)) RSS-GEN 5.5, RSS 102

1. The measured output power was calculated from the peak field strength measurements using the following equation:

Channel	Frequency	Peak Field Strength	Distance	Antenna Gain ¹	Measured Output Power
	(MHz)	(dBµV/m)	(m)	(dBi)	(mW)
1	1395.9	111.87	3.0	2.0	29.11
3	1399.1	110.78	3.0	2.0	22.65
4	1427.9	111.09	3.0	2.0	24.32
6	1431.1	111.38	3.0	2.0	26.00

¹ Antenna gain value was supplied by the manufacturer

$$P = \frac{(E \times d)^2}{(30 \times G)}$$

P = the power in Watts.

E = the measured maximum field strength in V/m

G = the numeric gain of the transmitting antenna over an isotropic radiator.

d = the distance in meters of the field strength measurement.

2. The DUT output power was derived from the measured output power in the above table to determine the power density.

Channel Frequency	MPE Distance (cm)	DUT Output Power (dBm)	DUT Antenna Gain (dBi)	Power Density		Limit (mW/cm ²)	Result
				(mW/cm ²)	(W/m ²)		
				(1)	(2)		
1395.9	20.0	14.64	2.0	0.0091802	0.091802	0.93	Compliant
1399.1	20.0	13.55	2.0	0.0071425	0.071425	0.93	Compliant
1427.9	20.0	13.86	2.0	0.0076710	0.076710	0.95	Compliant
1431.1	20.0	14.15	2.0	0.0082007	0.082007	0.95	Compliant

$$PD = \frac{OP + AG}{(4 \times \pi \times d^2)}$$

PD = Power Density (mW/cm²)

OP = DUT Output Power (dBm)

AG = DUT Antenna Gain (dBi)

d = MPE Distance (cm)

- Reference CFR 2.1093(b): For purposes of this section, a portable device is defined as a transmitting device designed to be used so that the radiating structure(s) of the device is/are within 20 centimeters of the body of the user.
- Section 7.1 of this test report. Output power was calculated from the measured field strength.
- Antenna gain value for this product was taken from the client's specification data sheet.
- Power density is calculated from power measurement and antenna gain.
- Reference CFR 1.1310, Table 1: Limits for Maximum Permissible Exposure (MPE), Section (B): Limits for General Population/Uncontrolled Exposure.

8. Test Site Description

Compliance Worldwide is located at 357 Main Street in Sandown, New Hampshire. The test sites at Compliance Worldwide are used for conducted and radiated emissions testing in accordance with Federal Communications Commission (FCC) and Industry Canada standards. A description of the test sites is on file with the FCC (registration number **96392**) and Industry Canada (file number **IC 3023A-1**).

The radiated emissions test site is a 3 and 10 meter enclosed open area test site (OATS). Personnel, support equipment and test equipment are located in the basement beneath the OATS ground plane.

The conducted emissions site is part of a 16' x 20' x 12' ferrite tile chamber and uses one of the walls for the vertical ground plane required by EN 55022.

Both sites are designed to test products or systems 1.5 meter W x 1.5 meter L x 2.0 meter H, floor standing or table top.