

# US Type Charger 48A

---

## Installation Manual

Revision 0.1



# IMPORTANT SAFETY INSTRUCTIONS

## INSTRUCTIONS IMPORTANTES CONCERNANT LA SÉCURITÉ

This document contains instructions and warnings that must be followed when installing and using the Electric Vehicle Supply Equipment (EVSE). Before installing or using the EVSE, read this entire document as well as WARNING and CAUTION markings in this document.

### Safety Instructions

The symbols used have the following meaning:

---



WARNING: RISK OF ELECTRIC SHOCK



WARNING: RISK OF PERSONAL INJURY



WARNING: RISK OF FIRE OR EXPLOSION



CAUTION: RISK OF DAMAGE TO THE EQUIPMENT

---

- The information provided in this manual in no way exempts the user of responsibility to follow all applicable codes or safety standards.
- This document provides instructions for the Electric Vehicle Supply Equipment (EVSE) and should not be used for any other product.

### Repair and Maintenance Clause

- Only licensed electricians can repair or maintain the charger. It is forbidden for general users to repair or maintain it.
- Turn off input power before repair or maintenance the charger.

**WARNING: RISK OF ELECTRIC SHOCK**

Basic precautions should always be followed when using electrical products, including the following. This manual contains important instructions that shall be followed during installation, operation and maintenance of the unit.

- Read all the instructions before using this equipment.
- This equipment should be supervised when used around children.
- Do not put fingers into the EV connector.
- Do not use this equipment if the flexible power cord or EV cable is frayed, has broken insulation, or any other signs of damage.
- Do not use this equipment if the enclosure or the EV connector is broken, cracked, open, or shows any other indication of damage.

**WARNING: RISK OF PERSONAL INJURY**

- This equipment is intended only for charging vehicles that do not require ventilation during charging.
- Do not use extender cables to increase the length of the charging cable. Maximum length is limited to 25 feet by the National Fire Protection Agency.

**WARNING: RISK OF ELECTRIC SHOCK**

- Do not touch live electrical parts. Incorrect connections may cause electric shock.
- Do not remove cover or attempt to open the enclosure. No user serviceable parts inside. Refer servicing to qualified service personnel.

**CAUTION: RISK OF DAMAGE TO THE EQUIPMENT**

- Do not operate this equipment in temperatures outside its operating range of -30°C to +50°C (-22°F to +122°F).
- Store this equipment in a clean dry place in temperatures between -40°C and +80°C (-40°F to +176°F).
- Do not connect to a circuit operating at more than 150 volts to ground.

**WARNING: RISK OF FIRE OR EXPLOSION**

- Do not use this device with an extension cord.
- To reduce the risk of fire, replace only with same type and ratings of fuse.

**SAVE THESE INSTRUCTIONS**  
**CONSERVER CES INSTRUCTIONS**

## **Federal Communication Commission Interference Statement**

This equipment complies with part 15 of the FCC Rules. Operation is subject to the following two conditions: (1) This equipment may not cause harmful interference, and (2) this equipment must accept any interference received, including interference that may cause undesired operation.

This equipment has been tested and found to comply with the limits for a Class B digital device, pursuant to part 15 of the FCC Rules. These limits are designed to provide reasonable protection against harmful interference in a residential installation. This equipment generates, uses and can radiate radio frequency energy and, if not installed and used in accordance with the instructions, may cause harmful interference to radio communications. However, there is no guarantee that interference will not occur in a particular installation. If this equipment does cause harmful interference to radio or television reception, which can be determined by turning the equipment off and on, the user is encouraged to try to correct the interference by one or more of the following measures:

- Reorient or relocate the receiving antenna.
- Increase the separation between the equipment and receiver.
- Connect the equipment into an outlet on a circuit different from that to which the receiver is connected.
- Consult the dealer or an experienced radio/TV technician for help.

Changes or modifications not covered in this guide must be approved in writing by the manufacturer's Regulatory Engineering Department. Changes or modifications made without written approval may void the user's authority to operate this equipment.

## **Radiation Exposure Statement**

This equipment complies with FCC radiation exposure limits set forth for an uncontrolled environment. This equipment should be installed and operated with minimum distance 20 cm between the radiator & your body.

## **Industry Canada Statement**

This equipment contains licence-exempt transmitter(s)/receiver(s) that comply with Innovation, Science and Economic Development Canada's licence-exempt RSS(s). Operation is subject to the following two conditions: (1) This equipment may not cause interference. (2) This equipment must accept any interference, including interference that may cause undesired operation of the device.

L'émetteur/récepteur exempt de licence contenu dans le présent appareil est conforme aux CNR d'Innovation, Sciences et Développement économique Canada applicables aux appareils radio exempts de licence. L'exploitation est autorisée aux deux conditions suivantes : (1) L'appareil ne doit pas produire de brouillage; (2) L'appareil doit accepter tout brouillage radioélectrique subi, même si le brouillage est susceptible d'en compromettre le fonctionnement.

## **Radiation Exposure Statement**

This equipment complies with ISED radiation exposure limits set forth for an uncontrolled environment. This equipment should be installed and operated with minimum distance 20 cm between the radiator & your body.

## **Déclaration D'exposition Aux Radiations**

Cet équipement est conforme aux limites d'exposition aux rayonnements ISED établies pour un environnement non contrôlé. Cet équipement doit être installé et utilisé avec une distance minimale de 20 cm entre le radiateur et votre corps.

# Contents

<b>1 Introduction</b> .....	<b>8</b>
1.1 Product View.....	8
<b>2 Specification</b> .....	<b>12</b>
2.1 Product specifications .....	12
<b>3 Installation</b> .....	<b>14</b>
3.1 Before Installation .....	14
3.1.1 Safety Check.....	14
3.1.2 Grounding Instructions .....	14
3.2 Tools & Parts Required for Installation.....	15
3.3 Charger Installation .....	16
3.4 Input Power Cord Installation.....	21
3.5 Holster Installation .....	24
3.6 Operating Current .....	27
3.7 Service Wiring.....	28
3.7.1 240V Split-Phase.....	28
3.7.2 208V 3-Phase Wye-Connected.....	28
3.7.3 240V Three-Phase Delta-Connected.....	29
<b>4 Operations</b> .....	<b>31</b>
4.1 Charging Status Indicators .....	31
4.2 Authorization (for IC only) .....	32
4.2.1 Online Authorization .....	32
4.2.2 Local Authorization.....	32
4.3 Charging an Electric Vehicle (EV).....	33
4.3.1 Plug and Charge .....	33
4.3.2 RFID Card (for IC only).....	33
4.4 Stop Charging.....	33
4.4.1 Interrupt Charging.....	33
4.4.2 Auto Restart .....	34
4.4.3 Power Outage Recovery.....	34
4.5 General Care .....	34
4.6 Customer Support .....	34

## List of Figures

Figure 1-1 Front View .....	8
Figure 1-2 Box Contents .....	9
Figure 1-3 Opening the Carton .....	10
Figure 1-4 Charger Device .....	10
Figure 1-5 Take Out the Charger .....	11
Figure 1-6 Remove the Mounting Bracket .....	11
Figure 3-1 Loosen 2 Pcs M4 Screw .....	16
Figure 3-2 Remove the Top Cover Manually .....	16
Figure 3-3 Loosen 4 Pcs M4 Screw Then Open Install Cover .....	17
Figure 3-4 Position of SIM Card Socket .....	18
Figure 3-5 SIM Card Insert / Eject Direction .....	18
Figure 3-6 Fasten Mounting Bracket .....	19
Figure 3-7 Screw Holes of Mounting Bracket .....	19
Figure 3-8 Charger and Mounting Bracket .....	20
Figure 3-9 Tighten M6 Screw .....	21
Figure 3-10 Conduit .....	21
Figure 3-11 Copper Terminal, Heat Shrink Tube and Copper Wire .....	22
Figure 3-12 Cable Input Position .....	22
Figure 3-13 Input Wiring Position .....	23
Figure 3-14 Separate the Holster .....	24
Figure 3-15 Secure the Hook .....	24
Figure 3-16 Secure the Holster .....	25
Figure 3-17 Rotate the Holster .....	25
Figure 3-18 Tighten Screws .....	26
Figure 3-19 Place the EV Charging Plug into the Holster .....	26
Figure 3-20 Split-Phase .....	28
Figure 3-21 208V 3-Phase Wye-Connected .....	29
Figure 3-22 240V 3-Phase Delta-Connected .....	30
Figure 4-1 Online Authorization .....	32
Figure 4-2 Local Authorization .....	32
Figure 4-3 Connect the Charging Plug to the EV .....	33

## List of Tables

Table 1-1 Accessories in the Box.....	9
Table 2-1 Product Specifications.....	12
Table 3-1 Tools & Parts Required for Installation .....	15
Table 3-2 DIP Switch Configuration.....	27
Table 4-1 Charging status indicators.....	31



# 1 Introduction

This user manual applies to “48A Level 2 AC Charger for Plug-in Electric Vehicles (PEVs) and Battery Electric Vehicles (BEVs)”.

The Level 2 Electric Vehicle Supply Equipment (EVSE) with 48A capabilities will be used in North America. It can provide a shorter charging time than the 16A and 32A EVSE.

**!!! Any unauthorized modifications will void the manufacturer’s warranty. !!!**

## 1.1 Product View

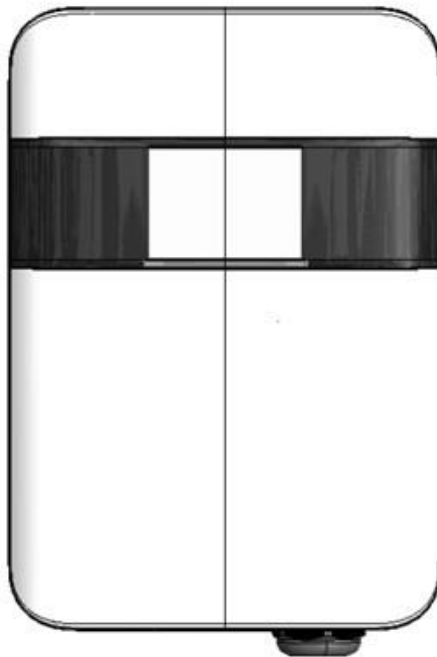

Figure 1-1 Front View

## Box Contents

Inside the box, you will find the following accessories.

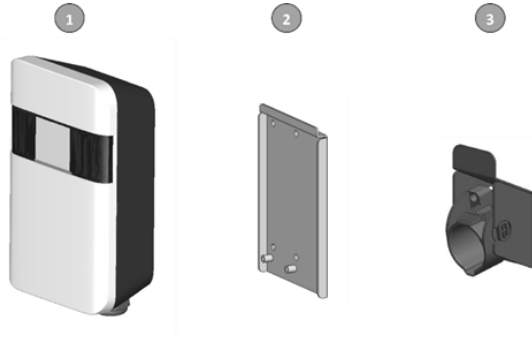

Figure 1-2 Box Contents

Table 1-1 Accessories in the Box

Item	Description	QTY	Remark
1	Basic(BC)/Smart(SC)/Smart+(SC+)/Intelligent(IC) Charger-48A	1	Depending on your order content
2	Mounting Bracket	1	Attached to the back of the charger
3	Holster Assembly	1	With Hook x1, Holster x1, M4xL15 tapping screw x2

## Carton Opening Process

1. Open the carton and remove the EPE Form.

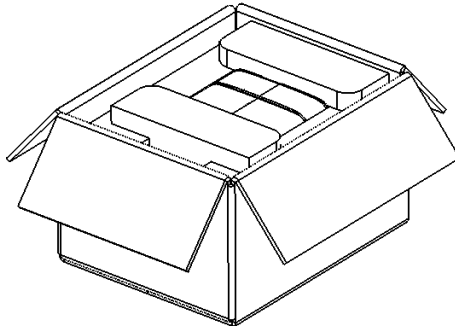

Figure 1-3 Opening the Carton

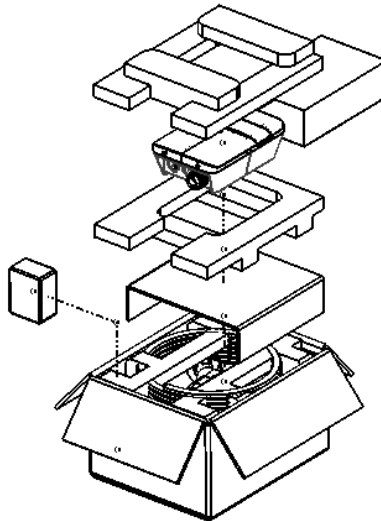

Figure 1-4 Charger Device

2. Take out the charger and then remove the mounting bracket before installing it.

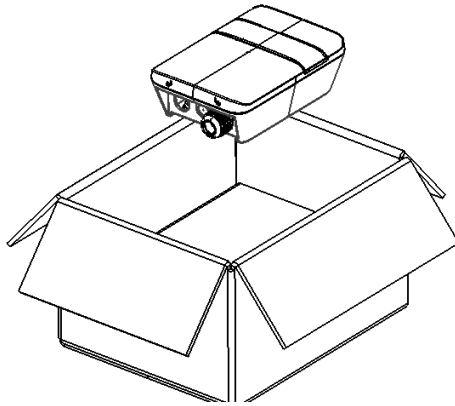

Figure 1-5 Take Out the Charger

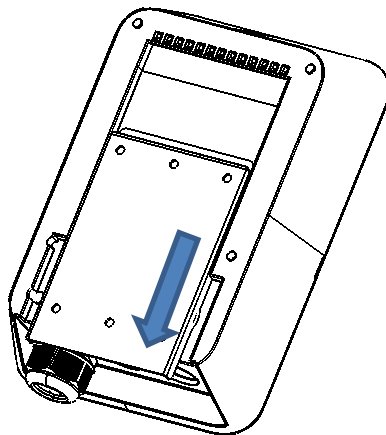

Figure 1-6 Remove the Mounting Bracket

# 2 Specification

## 2.1 Product specifications

Table 2-1 Product Specifications

Item	BC_48A	SC_48A	SC+_48A	IC_48A
Application	Residential	Commercial		
Voltage (Vac)	208/240VAC (-20% ~ + 15%), Single Phase			
Frequency (Hz)	60Hz			
Current (Rms)	Max. 48 A			
Charging Connector	SAE J1772 Type 1			
Indications	<ul style="list-style-type: none"> <li>• Green Steady: Ready</li> <li>• Green Flashing (Fast): Authorized, wait for EV Connect</li> <li>• Green Flashing (Slow): Suspend (Occupying)</li> <li>• Blue Steady: Charging complete</li> <li>• Blue Flashing (Slow): Charging</li> <li>• Red Steady: Unrecoverable Fault</li> <li>• Red Flashing (Slow): Recoverable Fault</li> <li>• Yellow Steady: Out of service</li> <li>• Yellow Flashing (Slow): Booting / Firmware Upgrading</li> </ul>			
Wi-Fi	N/A	802.11 b/g/n		
Ethernet	N/A	YES		
BLE	YES	N/A		
Cellular	N/A			M2M connection (LTE CAT1)
RFID	N/A		ISO 14443 A/B, ISO 15693, Felica	
Display	N/A	3.5" LCD Display with 550 nits luminance		
Data Protocol	N/A	OCPP 1.6 & 2.0 JSON		
Operation Temp.	-30 ~ 50 °C (-22 to 122°F)			
Storage Temp.	-40 ~ 80 °C (-40 to 176°F)			
Mounting Type	Wall mount / Pole mount (optional)			
Wiring Type	Hard-wired			
Enclosure Level	NEMA 4			
Impact Resistance	IK10			

Dimension (H x W x D)	208 x 300 x 97 mm3			
Web Portal Management	N/A	Yes		
Operating Humidity	5% to 95%, non-condensing			
Operating Altitude	0 to 3500m			
Certification	UL 1998/2231/2594 FCC Part 15B/Energy Star			
	FCC Part 15.247 (Bluetooth 2.4GHz)	FCC Part 15.247 (WLAN 2.4GHz)	FCC Part 15.225 (RFID 13.56MHz) FCC Part 15.247 (WLAN 2.4GHz)	FCC Part 15.225 (RFID 13.56MHz) FCC Part 15.247 (WLAN 2.4GHz)
	N/A			FCC Part 22/24/27
	N/A	CTEP		

# 3 Installation

## 3.1 Before Installation

### 3.1.1 Safety Check

- Check for transport damages.
- Before connecting the product to the power supply, check that the power supply voltage and current rating corresponds with the power supply details shown on the product rating label.



#### **CAUTION**

- Disconnect the power supply before installing or repairing the charger. Failure to do so may result in physical injury or damage to the power supply system and the charger.
- Avoid touching or pressing the LCD screen all times, as this may result in damage to the LCD screen.
- Cord extension sets are not allowed to be used.



#### **DANGER: RISK OF SUFFOCATION**

Keep any packing materials away from children – these materials are potential source of danger, e.g. suffocation.

The charger must be installed only by a licensed electrician in accordance with the provisions of the local electrical industry construction and should comply with National Electrical Codes and standards.

Before installing the charger, make sure you have read all of these instructions in this manual and fully understand its contents.

Appropriate protection is required when connecting to a main switchboard. The tools and parts used as outlined in the section 3.2 “Tools & parts required for installation”.

### 3.1.2 Grounding Instructions

The charger must be implemented equipment grounding through a permanent wiring system or an equipment grounding conductor. Use a wire with a dedicated grounding wire and a ring terminal and connect to the equipment ground terminal block for grounding.

This product must be connected to a grounded, metal, permanent wiring system, or an equipment- grounding conductor must be run with the circuit conductors and connected to the equipment grounding terminal or lead on the product.

**WARNING: RISK OF ELECTRIC SHOCK**

Improper connection of the equipment grounding conductor can result in a risk of electric shock. Check with a qualified electrician or serviceman if you are in doubt as to whether the product is properly grounded.

## 3.2 Tools & Parts Required for Installation

Table 3-1 Tools &amp; Parts Required for Installation

Tool	QTY	Model	Size	Remark
Mounting Bracket	1	All	222x173x9 mm	Fasten charger to the wall
Holster Assembly	1	All	58x58x70 mm	Hold EV charging plug
Screw	4	All	Tapping: #12 Mechanical: M6	Fasten Mounting Bracket & Holster
	2	All	Mechanical: M4	
Wire, Copper	2	All	6 AWG	
	1	All	10 AWG	
Heat Shrink Tube	2	All	6 AWG	Protect wires & terminals
	1	All	10 AWG	
Terminal	2	All	6 AWG	Connect input wires to the terminal block
	1	All	10 AWG	
Conduit	1	All	1 inch	Protect power cable
Philips Screwdriver	1	All	PH2	
Torx Screwdriver	1	All	T20	
Hexagon Socket	1	All	5/16	Tighten #12 Tapping screws
Torque Wrench	1	All	40 kgf-cm min	



## 3.3 Charger Installation

### 1. Disassemble top cover.



Figure 3-1 Loosen 2 Pcs M4 Screw



Figure 3-2 Remove the Top Cover Manually

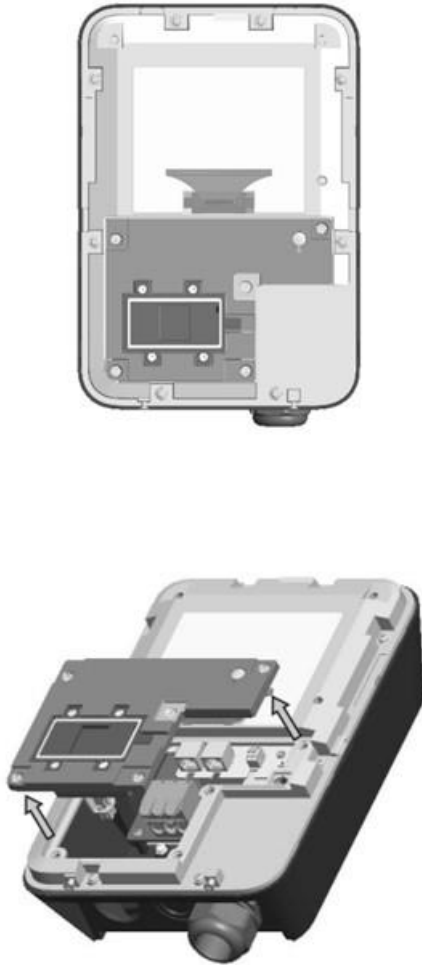

Figure 3-3 Loosen 4 Pcs M4 Screw Then Open Install Cover

## 2. Find SIM card socket. (Only for Intelligent Charger)

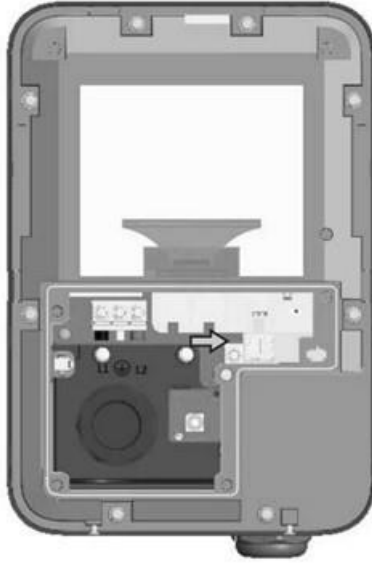

Figure 3-4 Position of SIM Card Socket

## 3. Insert SIM card. (Only for Intelligent Charger)

3-1 Unlock the SIM card socket.

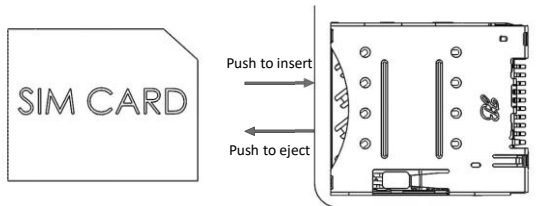

Figure 3-5 SIM Card Insert / Eject Direction

#### 4. Secure the main body mounting bracket to the wall with appropriate screw.

Follow applicable accessibility requirements for the mounting position. The unit shall be stored or located at a sufficient height.

For indoor site, this device shall be mounted at a sufficient height from grade such that the height of the storage means for the coupling device is located between 450 mm (18 inches) and 1.2 m (4 feet) from grade.

For outdoor site, this device shall be mounted at a sufficient height from grade such that the height of the storage means for the coupling device is located between 600 mm (24 inches) and 1.2 m (4 feet) from grade. Refer to Article 625, NEC.

The mounting bracket has ten screw holes. If only two screws be used to fasten the mounting bracket, the screws should pass through the middle two screw holes of the mounting bracket. The other screw holes are reserved for the user.

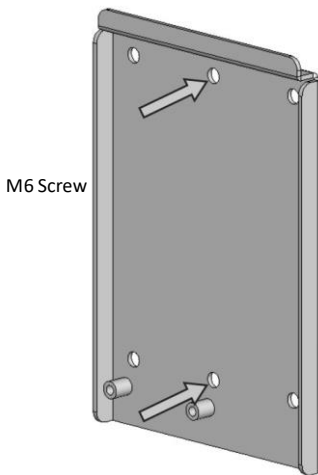

Figure 3-6 Fasten Mounting Bracket

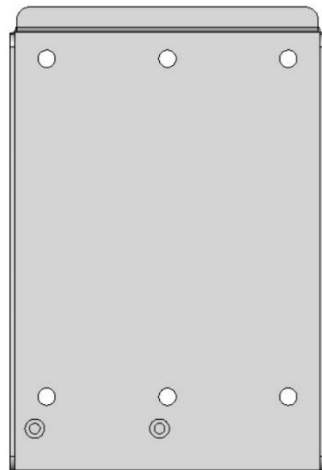

Figure 3-7 Screw Holes of Mounting Bracket

Screw sizing suggestion:

- A. For masonry walls, use M6 mechanical screws. (Commercially Available)
- B. For finished walls supported by wood studs, use #12 tapping screws. (Model Accessories)
- C. Please refer to the following torque. The actual torque is according to the wall material.

Screw	Torque	
M6	25 kgf.cm min	21.7 lb-in min

Screw	Torque	
#12	25 kgf.cm min	21.7 lb-in min

## 5. Fasten charger onto mounting bracket.

- 5-1. Put the charger on the mounting bracket.
- 5-2. Fasten charger on mounting bracket by tightening M6 screw.
- 5-3. Please refer to the following torque.

Screw	Torque	
M4	15 kgf.cm	12 lb/in

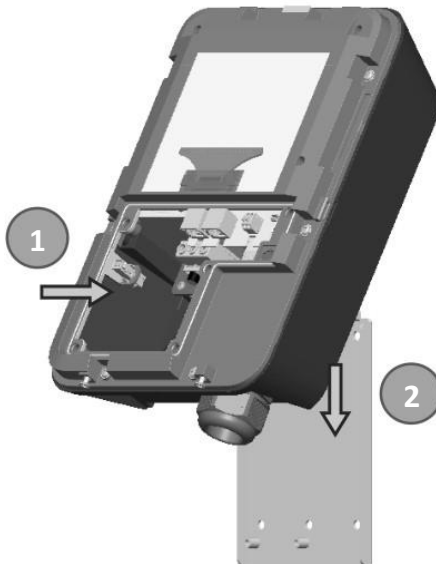

Figure 3-8 Charger and Mounting Bracket

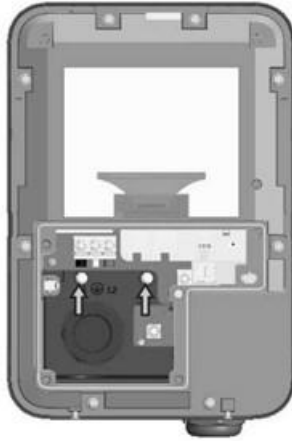

Figure 3-9 Tighten M6 Screw

## 3.4 Input Power Cord Installation

1. Choose the appropriate conduit in accordance with all applicable state, local and National Electrical Codes and standards.

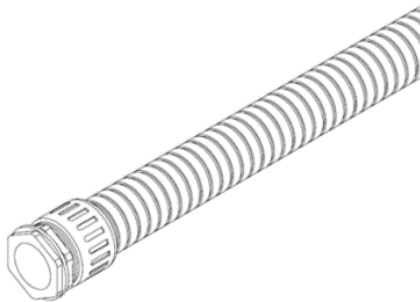

Figure 3-10 Conduit

## 2. Clamp copper terminal to connect copper wire. The clamping point is covered by heat shrink tube for protecting.

2-1 Refer to the following wire specification. Use conductor type other than RHH, RHW and RHW-2 with outer covering.

Model	Terminal	Conductor	Rating
Basic(BC)/Smart(SC)/Smart+(SC+)/Intelligent(IC) Charger-48A	L1, L2, G	L1/L2: 6AWG G: 10 AWG	90C copper wire



Figure 3-11 Copper Terminal, Heat Shrink Tube and Copper Wire

## 3. Electrical wiring to the charger.

3-1. Fold the wire end to pass through the conduit and insert them into the input hole (choose input direction 1 or 2 and open cap).

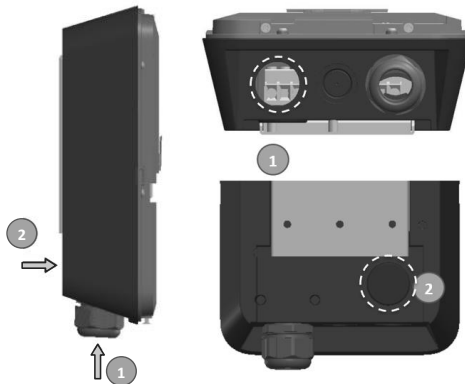

Figure 3-12 Cable Input Position

- 3-2. Fasten the copper wire on the corresponding terminal block. The wiring instruction is printed in front of the terminal block (L1/L2/G).

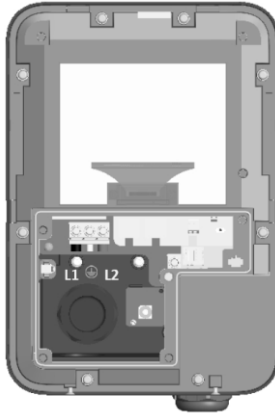

Figure 3-13 Input Wiring Position

- 3-3. Use the following torque to connect the wire terminal to the terminal block.

Screw	Torque	
M4	12.1 kgf.cm	10.5 lb-in



**CAUTION:**

To reduce the risk of fire, connect only to a circuit provided with 60 amperes maximum branch circuit overcurrent protection in accordance with the National Electrical Code, ANSI/NFPA 70, and the Canadian Electrical Code, Part I, C22.2.



**CAUTION:**

If this unit is installed outdoors, the outlet must be rated for outdoor installation. The outlet must be installed properly to maintain the proper NEMA rating of the enclosure.

- 3-4. Lock the conduit on the enclosure. Please refer to the following torque.

Conduit	Torque	
1 "	35 kgf.cm	30.36 lb-in



3-5. Reassemble Install cover and Front cover then Fasten M4 screw.

Screw	Torque	
	M4	15 kgf.cm

## 3.5 Holster Installation

### 1. Separate the holster from the hook.

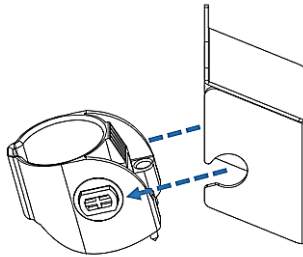

Figure 3-14 Separate the Holster

### 2. Fasten the hook on the wall with appropriate screws.

2-1. For finished walls supported by wood studs, use 2pcs screws (#12 tapping or M6) .

2-2. The recommend torque is 25 kgf.cm (21.7 lb-in).

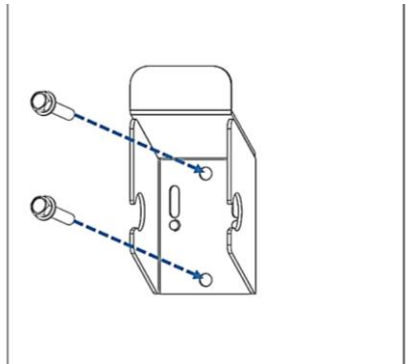

Figure 3-15 Secure the Hook

**3. Make the holster face up and combine with the hook.**

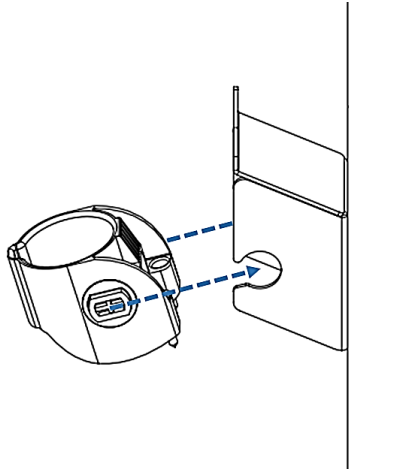

Figure 3-16 Secure the Holster

**4. Rotate the holster down thoroughly.**

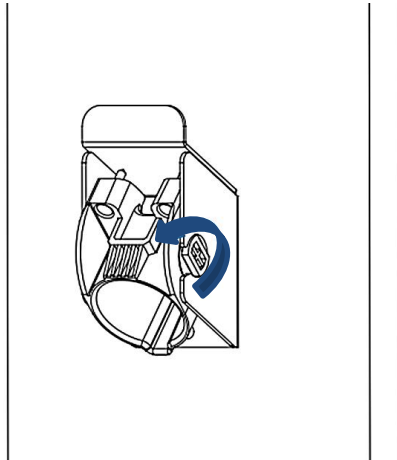

Figure 3-17 Rotate the Holster

**5. Keep the holster in this state and tighten screws completely.**

5-1. The recommend torque is 6 kgf.cm (5.2 lb-in). The screws make the holster assembly firm.

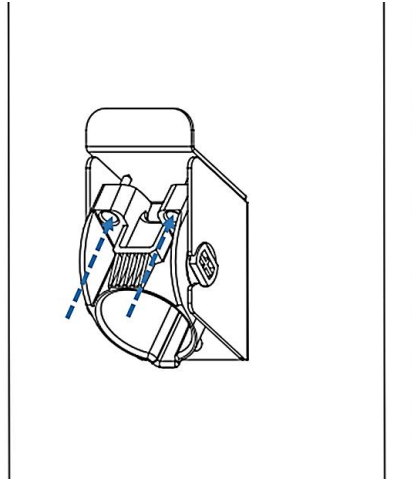

Figure 3-18 Tighten Screws

**6. Place the EV charging plug into the holster.**

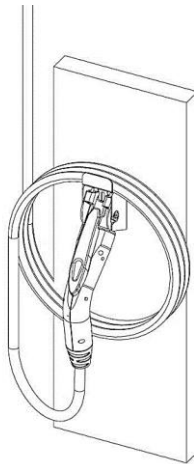







Figure 3-19 Place the EV Charging Plug into the Holster



## 3.6 Operating Current

To set the operating current, please configure 0-7 from DIP switch.

**WARNING:** Power must remain off before setting or configuring the DIP switch.

Table 3-2 DIP Switch Configuration

Item	Output current	Circuit Breaker	Specification
DIP switch configuration	12A	15A	
	16A	20A	
	20A	25A	
	24A	30A	
	32A	40A	
	36A	45A	

	40A	50A	
	48A (Default)	60A	

## 3.7 Service Wiring

### 3.7.1 240V Split-Phase

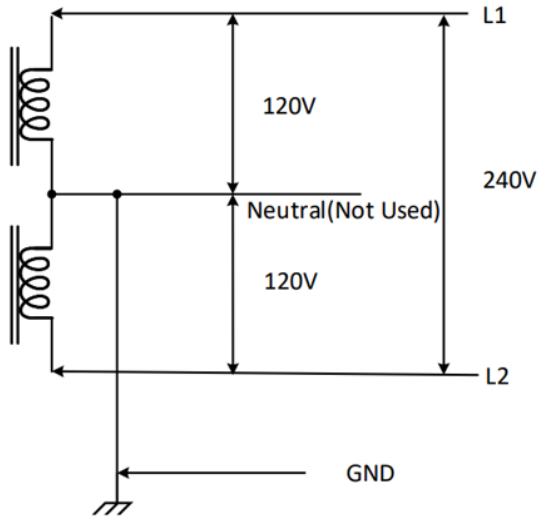

Figure 3-20 Split-Phase

### 3.7.2 208V 3-Phase Wye-Connected

With a Wye-connected secondary, any two of the legs can be used to provide 208V to the Wall Connector. For example, L1 and L2, or L1 and L3, or L2 and L3. The two used phases must each measure 120V to neutral.

**Note:** A current-carrying neutral is not required.

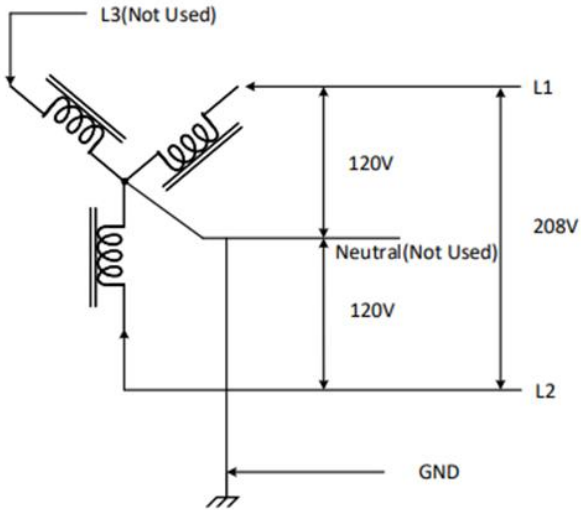

Figure 3-21 208V 3-Phase Wye-Connected

**Caution:** The unused leg (L3 in the illustration) must remain open. Do not connect to a neutral bar, or to earth ground.

**Caution:** The center point of the three phases (normally used as neutral) must be grounded to earth at only one point. This is usually at the breaker panel.

### 3.7.3 240V Three-Phase Delta-Connected

With the delta connection, one leg must be center tapped, and only the two phases on either side of the center tap can be used. The two used phases must each measure 120V to neutral.

Consult the transformer manufacturer's literature to verify that the single leg can supply the required power.

**Note:** The Wall Connector's contactor closes only if it detects the presence of an earth ground wire connected to a neutral point on the transformer secondary.

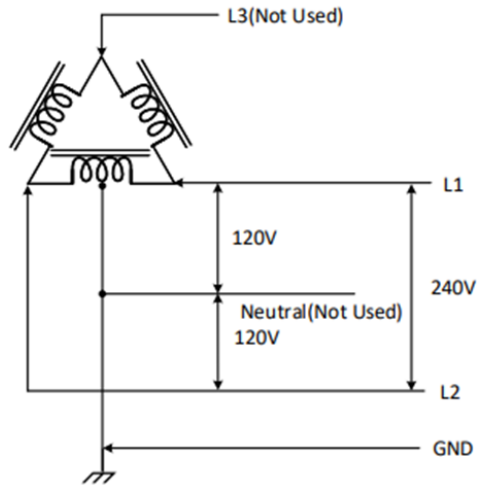

Figure 3-22 240V 3-Phase Delta-Connected









**Caution:** The third line (L3 in the illustration) of the delta is 208V, with respect to neutral, and is sometimes referred to as a “stinger.” Do not use this third line.

**Caution:** Do not use a three-phase delta-connected transformer secondary without a center tap on one leg. No neutral point is available for the required earth ground connection.

# 4 Operations

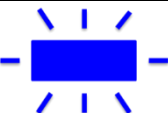
## 4.1 Charging Status Indicators

Table 4-1 Charging Status Indicators

LED Indicator	Description	Definition
	Not illuminated	Power Off
	Green Steady	Ready
	Green Flashing	Flashing green (Fast): Authorized, wait for EV Connect Flashing green (Slow): Suspend EV
	Blue Steady	Charging complete
	Blue Flashing	Flashing blue (Slow): Charging
	Red Steady	Unrecoverable Fault
	Red Flashing	Recoverable Fault
	Yellow Steady	Out of Service
	Yellow Flashing	Booting / Firmware Upgrading



## 4.2 Authorization (for SC+ and IC only)

Before the owner of an Electric Vehicle can start or stop charging, the user must get authorized to continue with the operation.

### 4.2.1 Online Authorization

Description:

- Generally, before the owner of an electric vehicle can start or stop charging, the user must get authorized to continue with the operation. The EVSE SHALL only supply energy after authorization.

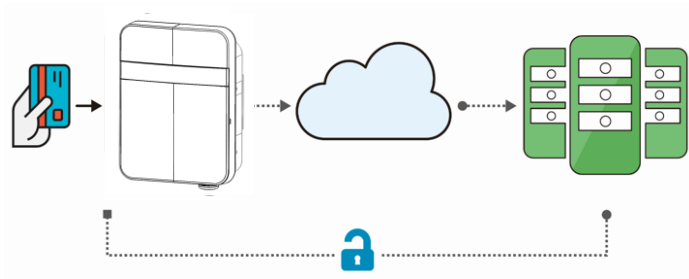

Figure 4-1 Online Authorization

### 4.2.2 Local Authorization

Description:

- Synchronized with the Central System when EVSE is Online.
- To improve the experience for users, the EVSE MAY support local authorization when EVSE is *offline*, and faster authorization response time when communication between charger and Central System is slow.

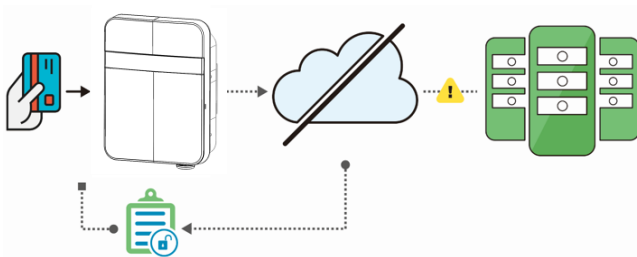

Figure 4-2 Local Authorization

## 4.3 Charging an Electric Vehicle (EV)

Choices of start charging are as below:

### 4.3.1 Plug and Charge

1. Insert the charging plug into the EV
2. Charging session starts

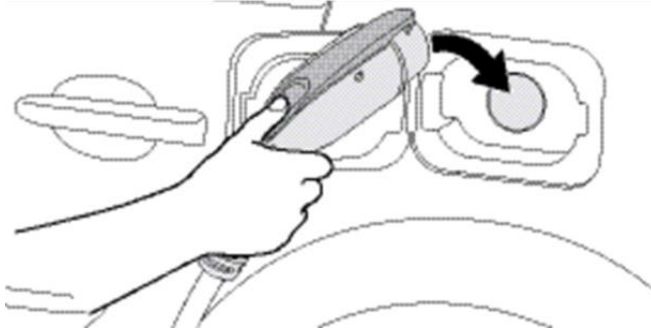

Figure 4-3 Connect the Charging Plug to the EV

### 4.3.2 RFID Card (for SC+ and IC only)

1. Insert the charging plug into the EV
2. Swipe card
3. Wait for authorization
4. Charging session starts

## 4.4 Stop Charging

1. Unplug any time (disconnect the charging plug from EV to stop charging session)
2. Session ends (please return the connector to the holster)

### 4.4.1 Interrupt Charging

Please refer to STOP CHARGING section for more information.

## 4.4.2 Auto Restart

When a charging session is interrupted due to a temporary error condition, the charger will automatically restart charging when the cause of the temporary error condition returns to normal. Status indicator lights remain flashing RED until the error condition is resolved.

- Temporary error conditions included: Over Current, Over Voltage, Under Voltage, and Over Temperature.
- For Over Current conditions: The charging session will be stop while OC occurs. After recovery from OC for 30 seconds, the charger will automatically restart charging for three times.
- When charging session stopped due to CCID trip, the charger will try to restart after 15 minutes for 3 times.

## 4.4.3 Power Outage Recovery

When power resumes after an outage, the charger restarts automatically with a delay ranging from 120 to 720 seconds. The delay is designed to avoid impacting the utility grid when multiple chargers are in the same area attempting to resume charging simultaneously.

## 4.5 General Care

The exterior of the charger is designed to be waterproof and dust proof. To ensure proper maintenance of the charger, follow these guidelines:

- Despite the water resistance of the enclosure, it is preferred to not direct streams of water at the unit. when cleaning it, clean with a soft, damp cloth.
- Make sure the charging plug is put back in the holster after charging to avoid damage.
- Ensure the power cable is stored on the charger after use to avoid damage.
- If the power cable or the charging plug is damaged, please contact Customer Support.

## 4.6 Customer Support

Please contact your reseller directly for technical support.