

# FCC Test Report

**FCC ID** : PPQ-WN4521L  
**Equipment** : 802.11ac, 2T2R Wireless LAN USB Module  
**Brand Name** : LITE-ON  
**Model Name** : WN4521L  
**Applicant** : Lite-On Technology Corp.  
Bldg. C, 90, Chien 1 Road, Chung Ho, New Taipei City  
23585, Taiwan, R.O.C  
**Manufacturer** : LITE-ON TECHNOLOGY (Changzhou) CO., LTD  
A9 Building, No.88 Yanghu Road, Wujin Hi-Tech  
Industrial Development Zone, Changzhou City,  
Jiangsu Province 213100 China  
**Standard** : 47 CFR FCC Part 15.407

The product was received on Jun. 26, 2018, and testing was started from Jul. 05, 2018 and completed on Jul. 10, 2018. We, SPORTON INTERNATIONAL INC. EMC & Wireless Communications Laboratory, would like to declare that the tested sample has been evaluated in accordance with the procedures given in ANSI C63.10-2013 and shown compliance with the applicable technical standards.

The report must not be used by the client to claim product certification, approval, or endorsement by TAF or any agency of government.

The test results in this report apply exclusively to the tested model / sample. Without written approval of SPORTON INTERNATIONAL INC. EMC & Wireless Communications Laboratory, the test report shall not be reproduced except in full.



Approved by: Allen Lin

**SPORTON INTERNATIONAL INC. EMC & Wireless Communications Laboratory**

No. 52, Huaya 1st Rd., Guishan Dist., Taoyuan City, Taiwan (R.O.C.)



# Table of Contents

**HISTORY OF THIS TEST REPORT .....3**

**SUMMARY OF TEST RESULT .....4**

**1 GENERAL DESCRIPTION .....5**

1.1 Information.....5

1.2 Testing Applied Standards .....8

1.3 Testing Location Information .....8

1.4 Measurement Uncertainty .....8

**2 TEST CONFIGURATION OF EUT.....9**

2.1 Test Condition .....9

2.2 Test Channel Mode .....9

2.3 The Worst Case Measurement Configuration .....11

2.4 Support Equipment.....12

2.5 Test Setup Diagram .....13

**3 TRANSMITTER TEST RESULT .....15**

3.1 AC Power-line Conducted Emissions .....15

3.2 Emission Bandwidth .....16

3.3 Maximum Conducted Output Power .....17

3.4 Peak Power Spectral Density.....19

3.5 Unwanted Emissions.....21

3.6 Test Equipment and Calibration Data .....27

**APPENDIX A. TEST RESULTS OF AC POWER-LINE CONDUCTED EMISSIONS**

**APPENDIX B. TEST RESULTS OF EMISSION BANDWIDTH**

**APPENDIX C. TEST RESULTS OF MAXIMUM CONDUCTED OUTPUT POWER**

**APPENDIX D. TEST RESULTS OF PEAK POWER SPECTRAL DENSITY**

**APPENDIX E. TEST RESULTS OF UNWANTED EMISSIONS**

**APPENDIX F. TEST PHOTOS**

**PHOTOGRAPHS OF EUT V01**



### History of this test report

| Report No. | Version | Description             | Issued Date   |
|------------|---------|-------------------------|---------------|
| FR862607AN | 01      | Initial issue of report | Jul. 26, 2018 |
|            |         |                         |               |
|            |         |                         |               |
|            |         |                         |               |
|            |         |                         |               |
|            |         |                         |               |
|            |         |                         |               |
|            |         |                         |               |
|            |         |                         |               |
|            |         |                         |               |
|            |         |                         |               |
|            |         |                         |               |
|            |         |                         |               |
|            |         |                         |               |
|            |         |                         |               |
|            |         |                         |               |
|            |         |                         |               |
|            |         |                         |               |
|            |         |                         |               |
|            |         |                         |               |
|            |         |                         |               |



### Summary of Test Result

| Report Clause | Ref. Std. Clause | Test Items                        | Result (PASS/FAIL) | Remark |
|---------------|------------------|-----------------------------------|--------------------|--------|
| 1.1.2         | 15.203           | Antenna Requirement               | PASS               | -      |
| 3.1           | 15.207           | AC Power-line Conducted Emissions | PASS               | -      |
| 3.2           | 15.407(a)        | Emission Bandwidth                | PASS               | -      |
| 3.3           | 15.407(a)        | Maximum Conducted Output Power    | PASS               | -      |
| 3.4           | 15.407(a)        | Peak Power Spectral Density       | PASS               | -      |
| 3.5           | 15.407(b)        | Unwanted Emissions                | PASS               | -      |

Reviewed by: Sam Tsai

Report Producer: Amber Chiu



# 1 General Description

## 1.1 Information

### 1.1.1 RF General Information

| Frequency Range (MHz) | IEEE Std. 802.11        | Ch. Frequency (MHz) | Channel Number |
|-----------------------|-------------------------|---------------------|----------------|
| 5150-5250             | a, n (HT20), ac (VHT20) | 5180-5240           | 36-48 [4]      |
| 5250-5350             |                         | 5260-5320           | 52-64 [4]      |
| 5470-5725             |                         | 5500-5700           | 100-140 [11]   |
| straddle 5725         |                         | 5720                | 144 [1]        |
| 5725-5850             |                         | 5745-5825           | 149-165 [5]    |
| 5150-5250             | n (HT40), ac (VHT40)    | 5190-5230           | 38-46 [2]      |
| 5250-5350             |                         | 5270-5310           | 54-62 [2]      |
| 5470-5725             |                         | 5510-5670           | 102-134 [5]    |
| straddle 5725         |                         | 5710                | 142 [1]        |
| 5725-5850             |                         | 5755-5795           | 151-159 [2]    |
| 5150-5250             | ac (VHT80)              | 5210                | 42 [1]         |
| 5250-5350             |                         | 5290                | 58 [1]         |
| 5470-5725             |                         | 5530-5610           | 106-122 [2]    |
| straddle 5725         |                         | 5690                | 138 [1]        |
| 5725-5850             |                         | 5775                | 155 [1]        |

| Band          | Mode           | BWch (MHz) | Nant |
|---------------|----------------|------------|------|
| 5.15-5.25GHz  | 802.11a        | 20         | 2TX  |
| 5.25-5.35GHz  | 802.11a        | 20         | 2TX  |
| 5.47-5.725GHz | 802.11a        | 20         | 2TX  |
| 5.725-5.85GHz | 802.11a        | 20         | 2TX  |
| 5.15-5.25GHz  | 802.11ac VHT20 | 20         | 2TX  |
| 5.25-5.35GHz  | 802.11ac VHT20 | 20         | 2TX  |
| 5.47-5.725GHz | 802.11ac VHT20 | 20         | 2TX  |
| 5.725-5.85GHz | 802.11ac VHT20 | 20         | 2TX  |
| 5.15-5.25GHz  | 802.11ac VHT40 | 40         | 2TX  |
| 5.25-5.35GHz  | 802.11ac VHT40 | 40         | 2TX  |
| 5.47-5.725GHz | 802.11ac VHT40 | 40         | 2TX  |
| 5.725-5.85GHz | 802.11ac VHT40 | 40         | 2TX  |
| 5.15-5.25GHz  | 802.11ac VHT80 | 80         | 2TX  |



| Band          | Mode           | BWch (MHz) | Nant |
|---------------|----------------|------------|------|
| 5.25-5.35GHz  | 802.11ac VHT80 | 80         | 2TX  |
| 5.47-5.725GHz | 802.11ac VHT80 | 80         | 2TX  |
| 5.725-5.85GHz | 802.11ac VHT80 | 80         | 2TX  |

Note:

- ♦ 11a, HT20 and HT40 use a combination of OFDM-BPSK, QPSK, 16QAM, 64QAM modulation.
- ♦ VHT20, VHT40, VHT80 use a combination of OFDM-BPSK, QPSK, 16QAM, 64QAM, 256QAM modulation.
- ♦ BWch is the nominal channel bandwidth.

1.1.2 Antenna Information

| Ant. | Port | Brand  | Model Name | Antenna Type    | Connector |
|------|------|--------|------------|-----------------|-----------|
| 1    | 2    | LITEON | WN4521L    | Printed Antenna | Murata    |
| 2    | 1    | LITEON | WN4521L    | Printed Antenna | Murata    |

| Ant. | Port | Gain (dBi) |     |
|------|------|------------|-----|
|      |      | 2.4G       | 5G  |
| 1    | 2    | 2.5        | 2.0 |
| 2    | 1    | 2.4        | 2.0 |

For 2.4 GHz function:

For IEEE 802.11b/g/n mode (2TX/2RX)

Ant. 1 (port 2) and Ant. 2 (port 1) could transmit/receive simultaneously.

For 5 GHz function:

For IEEE 802.11a/n/ac mode (2TX/2RX)

Ant. 1 (port 2) and Ant. 2 (port 1) could transmit/receive simultaneously.



1.1.3 EUT Information

| Operational Condition               |   |   |  |
|-------------------------------------|---|---|--|
| EUT Power Type                      | From Host System  |   |  |
| EUT Function                        | <input type="checkbox"/> Outdoor  | <input checked="" type="checkbox"/> Indoor              |  |
|                                     | <input type="checkbox"/> Fixed P2P  | <input type="checkbox"/> Client                         |  |
| Beamforming Function                | <input type="checkbox"/> With beamforming                                     | <input checked="" type="checkbox"/> Without beamforming |  |
| Weather Band                        | <input checked="" type="checkbox"/> With 5600~5650MHz                         | <input type="checkbox"/> Without 5600~5650MHz           |  |
| Type of EUT                         |   |   |  |
| <input checked="" type="checkbox"/> | Stand-alone   |   |  |
| <input type="checkbox"/>            | Combined (EUT where the radio part is fully integrated within another device) |   |  |
|                                     | Combined Equipment - Brand Name / Model No.:                                  | ...   |  |
| <input type="checkbox"/>            | Plug-in radio (EUT intended for a variety of host systems)                    |   |  |
|                                     | Host System - Brand Name / Model No.:   | ...   |  |
| <input type="checkbox"/>            | Other:  |   |  |

1.1.4 Mode Test Duty Cycle

| Mode           | DC    | DCF(dB) | T(s)           | VBW(Hz) ≥ 1/T  |
|----------------|-------|---------|----------------|----------------|
| 802.11a        | 0.998 | 0.009   | n/a (DC>=0.98) | n/a (DC>=0.98) |
| 802.11ac VHT20 | 0.997 | 0.013   | n/a (DC>=0.98) | n/a (DC>=0.98) |
| 802.11ac VHT40 | 0.999 | 0.004   | n/a (DC>=0.98) | n/a (DC>=0.98) |
| 802.11ac VHT80 | 0.981 | 0.083   | n/a (DC>=0.98) | n/a (DC>=0.98) |

## 1.2 Testing Applied Standards

According to the specifications of the manufacturer, the EUT must comply with the requirements of the following standards:

- ◆ 47 CFR FCC Part 15
- ◆ ANSI C63.10-2013
- ◆ KDB 789033 D02 v02r01
- ◆ KDB 662911 D01 v02r01

## 1.3 Testing Location Information

| Testing Location                           |        |  |                      |                      |
|--|--------|--|----------------------|----------------------|
| <input checked="" type="checkbox"/>        | HWA YA | ADD : No. 52, Huaya 1st Rd., Guishan Dist., Taoyuan City, Taiwan (R.O.C.)    | TEL : 886-3-327-3456 | FAX : 886-3-327-0973 |
| Test site Designation No. TW1190 with FCC. |        |  |                      |                      |
| <input type="checkbox"/>                   | JHUBEI | ADD : No.8, Ln. 724, Bo'ai St., Zhubei City, Hsinchu County, Taiwan (R.O.C.) | TEL : 886-3-656-9065 | FAX : 886-3-656-9085 |
| Test site Designation No. TW0006 with FCC. |        |  |                      |                      |

| Test Condition | Test Site No. | Test Engineer | Test Environment | Test Date   |
|----------------|---------------|---------------|------------------|-------------|
| AC Conduction  | TH01-HY       | Andy          | 23.5°C / 65%     | 05/Jul/2018 |
| RF Conducted   | 03CH09-HY     | Sam           | 23.2°C / 53.5%   | 05/Jul/2018 |
| Radiated       | CO04-HY       | Kevin         | 21°C / 56%       | 10/Jul/2018 |

## 1.4 Measurement Uncertainty

ISO/IEC 17025 requires that an estimate of the measurement uncertainties associated with the emissions test results be included in the report. The measurement uncertainties given below are based on a 95% confidence level (based on a coverage factor (k=2))

| Test Items                           | Uncertainty | Remark                   |
|--------------------------------------|-------------|--------------------------|
| Conducted Emission (150kHz ~ 30MHz)  | 3.6 dB      | Confidence levels of 95% |
| Radiated Emission (9kHz ~ 30MHz)     | 3.0 dB      | Confidence levels of 95% |
| Radiated Emission (30MHz ~ 1,000MHz) | 4.3 dB      | Confidence levels of 95% |
| Radiated Emission (1GHz ~ 18GHz)     | 3.9 dB      | Confidence levels of 95% |
| Radiated Emission (18GHz ~ 40GHz)    | 3.5 dB      | Confidence levels of 95% |
| Conducted Emission                   | 1.3 dB      | Confidence levels of 95% |
| Temperature                          | 0.7 °C      | Confidence levels of 95% |
| Humidity                             | 4 %         | Confidence levels of 95% |





## 2 Test Configuration of EUT

### 2.1 Test Condition

| Condition Item | Abbreviation/Remark | Remark |
|----------------|---------------------|--------|
| RF Conducted   | Abbreviation        | Remark |
| TnomVnom       | Tnom                | 20°C   |
| -              | Vnom                | 120V   |

### 2.2 Test Channel Mode

|                              |  |
|------------------------------|--|
| <b>Test Software Version</b> | REALTEK 11ac 8822BU USB WLAN MP Diagnostic Program 0.0006<br>00.20180227 |
|------------------------------|--|

| Mode                           | PowerSetting |
|--------------------------------|--------------|
| 802.11a_Nss1,(6Mbps)_2TX       | -            |
| 5180MHz                        | 51,52        |
| 5200MHz                        | 62,63        |
| 5240MHz                        | 62,63        |
| 5260MHz                        | 62,63        |
| 5300MHz                        | 62,63        |
| 5320MHz                        | 49,50        |
| 5500MHz                        | 45,46        |
| 5580MHz                        | 58,59        |
| 5700MHz                        | 49,49        |
| 5720MHz Straddle 5.47-5.725GHz | 61,61        |
| 5720MHz Straddle 5.725-5.85GHz | 61,61        |
| 5745MHz                        | 63,63        |
| 5785MHz                        | 63,63        |
| 5825MHz                        | 63,63        |
| 802.11ac VHT20_Nss1,(MCS0)_2TX | -            |
| 5180MHz                        | 53,54        |
| 5200MHz                        | 62,63        |
| 5240MHz                        | 62,63        |
| 5260MHz                        | 63,63        |
| 5300MHz                        | 63,63        |
| 5320MHz                        | 63,63        |





| Mode                           | PowerSetting |
|--------------------------------|--------------|
| 5500MHz                        | 44,45        |
| 5580MHz                        | 58,59        |
| 5700MHz                        | 40,40        |
| 5720MHz Straddle 5.47-5.725GHz | 61,61        |
| 5720MHz Straddle 5.725-5.85GHz | 61,61        |
| 5745MHz                        | 63,63        |
| 5785MHz                        | 63,63        |
| 5825MHz                        | 63,63        |
| 802.11ac VHT40_Nss1,(MCS0)_2TX | -            |
| 5190MHz                        | 34,34        |
| 5230MHz                        | 60,60        |
| 5270MHz                        | 63,63        |
| 5310MHz                        | 36,36        |
| 5510MHz                        | 32,32        |
| 5550MHz                        | 63,63        |
| 5670MHz                        | 41,41        |
| 5710MHz Straddle 5.47-5.725GHz | 61,61        |
| 5710MHz Straddle 5.725-5.85GHz | 61,61        |
| 5755MHz                        | 63,63        |
| 5795MHz                        | 63,63        |
| 802.11ac VHT80_Nss1,(MCS0)_2TX | -            |
| 5210MHz                        | 37,37        |
| 5290MHz                        | 35,36        |
| 5530MHz                        | 33,33        |
| 5610MHz                        | 50,50        |
| 5690MHz Straddle 5.47-5.725GHz | 62,62        |
| 5690MHz Straddle 5.725-5.85GHz | 62,62        |
| 5775MHz                        | 63,63        |

### 2.3 The Worst Case Measurement Configuration

| The Worst Case Mode for Following Conformance Tests |  |
|---|--|
| Tests Item  | AC power-line conducted emissions                        |
| Condition   | AC power-line conducted measurement for line and neutral |
| Operating Mode                                      | CTX  |
| 1   | USB mode   |

| The Worst Case Mode for Following Conformance Tests |   |
|---|---|
| Tests Item  | Emission Bandwidth<br>Maximum Conducted Output Power<br>Peak Power Spectral Density |
| Test Condition                                      | Conducted measurement at transmit chains  |

| The Worst Case Mode for Following Conformance Tests |   |  |   |
|---|---|--|---|
| Tests Item  | Unwanted Emissions  |  |   |
| Test Condition                                      | Radiated measurement<br>If EUT consist of multiple antenna assembly (multiple antenna are used in EUT regardless of spatial multiplexing MIMO configuration), the radiated test should be performed with highest antenna gain of each antenna type. |  |   |
| Operating Mode < 1GHz                               | CTX   |  |   |
| 1   | USB mode  |  |   |
| Operating Mode > 1GHz                               | CTX   |  |   |
| Orthogonal Planes of EUT                            | X Plane   | Y Plane  | Z Plane   |
|   |    |  |  |
| Worst Planes of EUT                                 |   |  | V   |

| The Worst Case Mode for Following Conformance Tests                                |                                    |
|--|------------------------------------|
| Tests Item   | Simultaneous Transmission Analysis |
| Operating Mode   | CTX                                |
| 1  | WLAN 2.4GHz                        |
| 2  | WLAN 5GHz                          |
| Refer to Sporton Test Report No.: FA862607 for Co-location RF Exposure Evaluation. |                                    |



## 2.4 Support Equipment

| Support Equipment – RF Conducted |                 |            |            |        |
|----------------------------------|-----------------|------------|------------|--------|
| No.                              | Equipment       | Brand Name | Model Name | FCC ID |
| 1                                | Notebook        | DELL       | E5410      | DOC    |
| 2                                | Adapter for NB  | DELL       | HA65NM130  | DOC    |
| 3                                | DC power supply | G.W        | GPS-3030DD | -      |

| Support Equipment – Radiated Emission |               |            |            |        |
|---------------------------------------|---------------|------------|------------|--------|
| No.                                   | Equipment     | Brand Name | Model Name | FCC ID |
| 1                                     | USB 2.0 Flash | -          | -          | -      |
| 2                                     | Mouse(USB)    | Dell       | MS111-L    | DOC    |
| 3                                     | iPod          | Apple      | A1199      | T41126 |
| 4                                     | Notebook      | DELL       | E5530      | DOC    |

| Support Equipment – AC Conduction |               |            |            |        |
|-----------------------------------|---------------|------------|------------|--------|
| No.                               | Equipment     | Brand Name | Model Name | FCC ID |
| 1                                 | USB 2.0 Flash | -          | -          | -      |
| 2                                 | Mouse(USB)    | Dell       | MS111-L    | DOC    |
| 3                                 | iPod          | Apple      | A1199      | T41126 |
| 4                                 | Notebook      | DELL       | E5530      | DOC    |

## 2.5 Test Setup Diagram

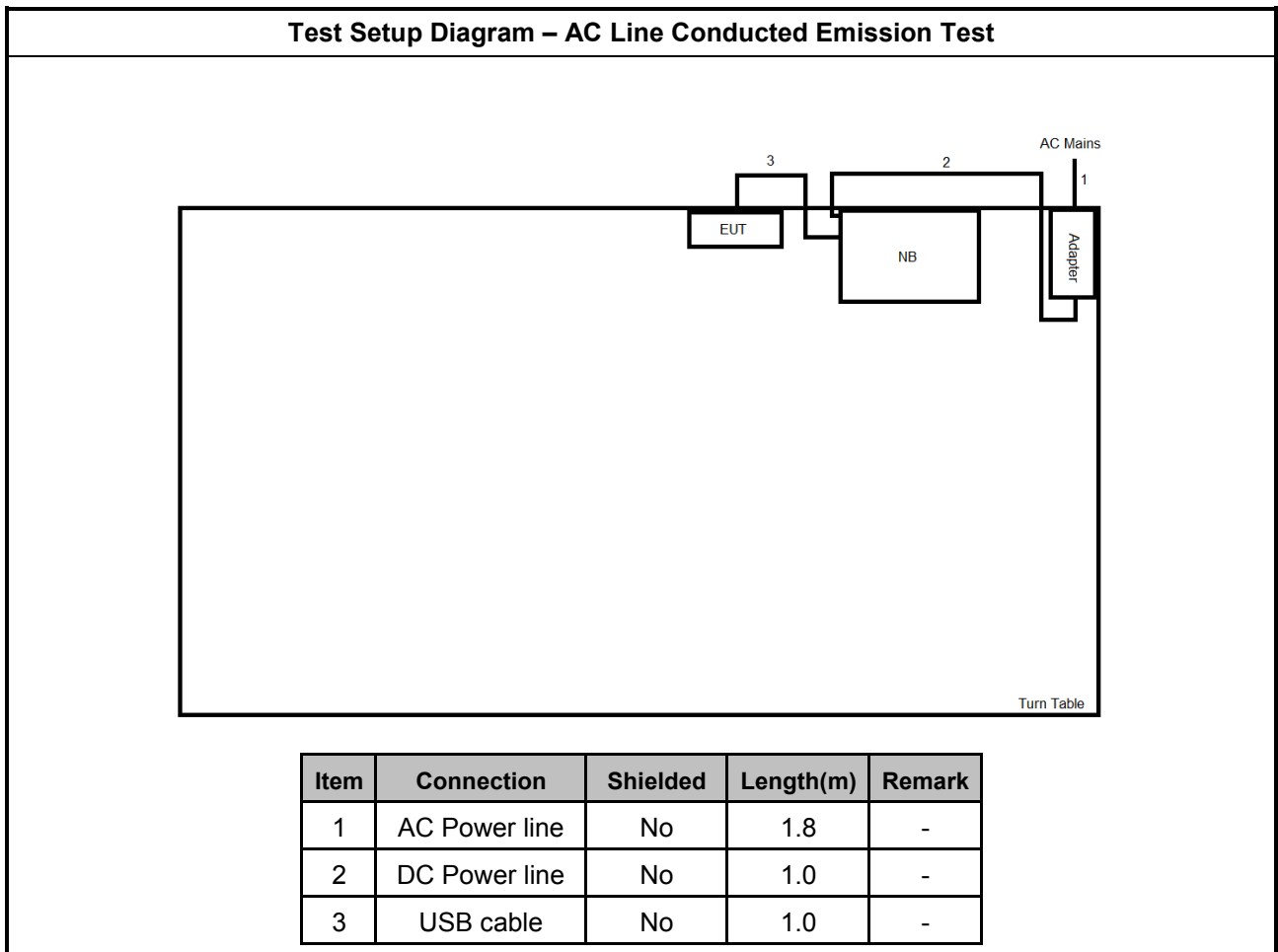

Test Setup Diagram - Radiated Test < 1GHz

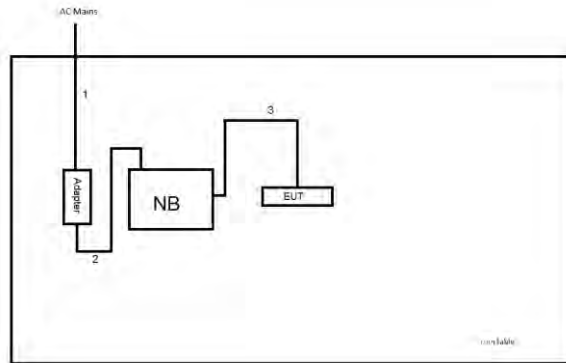

| Item | Connection    | Shielded | Length(m) | Remark |
|------|---------------|----------|-----------|--------|
| 1    | AC Power line | No       | 1.8       | -      |
| 2    | DC Power line | No       | 1.0       | -      |
| 3    | USB cable     | No       | 1.0       | -      |

### 3 Transmitter Test Result

#### 3.1 AC Power-line Conducted Emissions

##### 3.1.1 AC Power-line Conducted Emissions Limit

| AC Power-line Conducted Emissions Limit |            |           |
|---|------------|-----------|
| Frequency Emission (MHz)                | Quasi-Peak | Average   |
| 0.15-0.5                                | 66 - 56 *  | 56 - 46 * |
| 0.5-5                                   | 56         | 46        |
| 5-30                                    | 60         | 50        |

Note 1: \* Decreases with the logarithm of the frequency.

##### 3.1.2 Measuring Instruments

Refer a test equipment and calibration data table in this test report.

##### 3.1.3 Test Procedures

| Test Method  |
|--|
| <input checked="" type="checkbox"/> Refer as ANSI C63.10-2013, clause 6.2 for AC power-line conducted emissions. |

##### 3.1.4 Test Setup

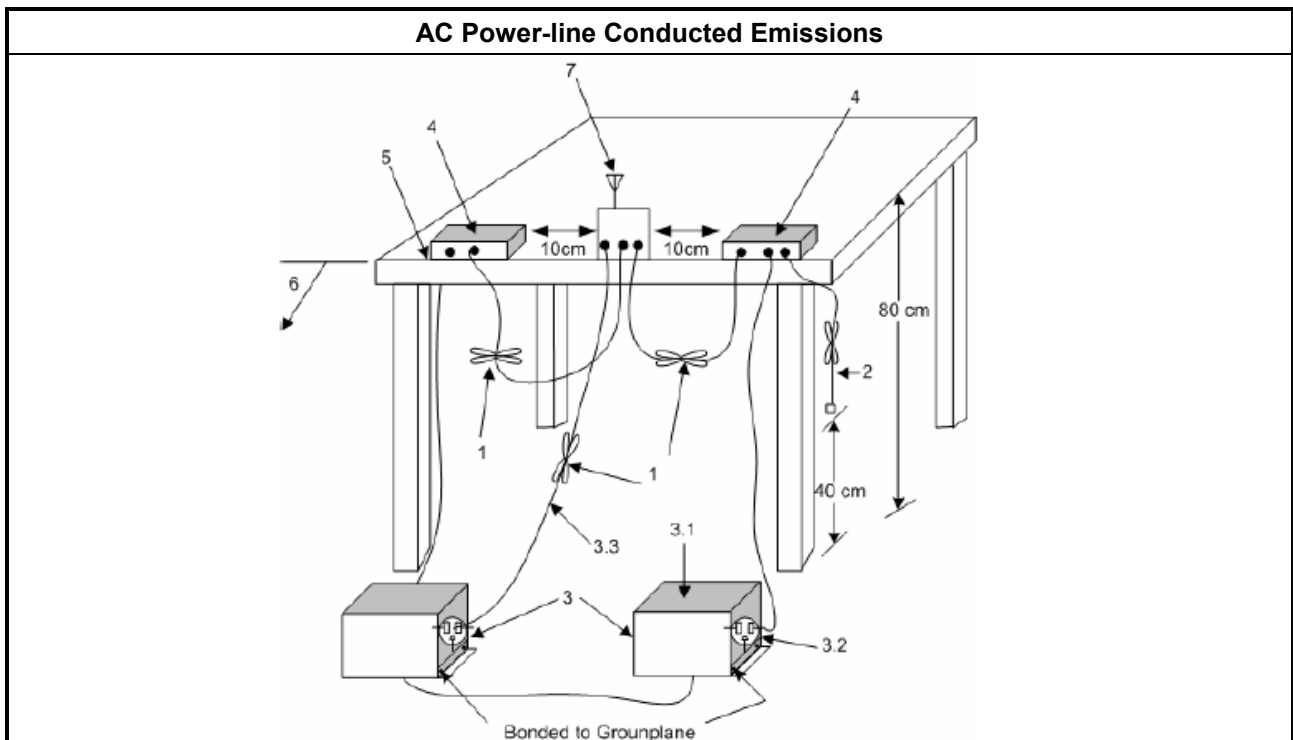

##### 3.1.5 Test Result of AC Power-line Conducted Emissions

Refer as Appendix A

### 3.2 Emission Bandwidth

#### 3.2.1 Emission Bandwidth Limit

| Emission Bandwidth Limit            |   |
|-------------------------------------|---|
| <b>UNII Devices</b>                 |   |
| <input checked="" type="checkbox"/> | For the 5.15-5.25 GHz band, N/A   |
| <input checked="" type="checkbox"/> | For the 5.25-5.35 GHz band, the maximum conducted output power shall not exceed the lesser of 250 mW or 11 dBm + 10 log B, where B is the 26 dB emission bandwidth in MHz.  |
| <input checked="" type="checkbox"/> | For the 5.47-5.725 GHz band, the maximum conducted output power shall not exceed the lesser of 250 mW or 11 dBm + 10 log B, where B is the 26 dB emission bandwidth in MHz. |
| <input checked="" type="checkbox"/> | For the 5.725-5.85 GHz band, 6 dB emission bandwidth $\geq$ 500kHz.   |

#### 3.2.2 Measuring Instruments

Refer a test equipment and calibration data table in this test report.

#### 3.2.3 Test Procedures

| Test Method  |   |
|--|---|
| <ul style="list-style-type: none"> <li>▪ For the emission bandwidth shall be measured using one of the options below:</li> </ul> |   |
| <input checked="" type="checkbox"/>  | Refer as KDB 789033, clause C for EBW and clause D for OBW measurement. |
| <input type="checkbox"/>   | Refer as ANSI C63.10, clause 6.9.3 for occupied bandwidth testing.      |
| <input type="checkbox"/>   | Refer as IC RSS-Gen, clause 6.7 for bandwidth testing.                  |

#### 3.2.4 Test Setup

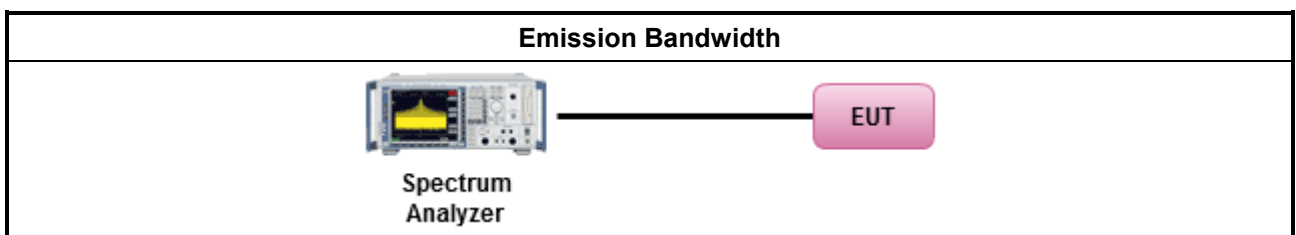

#### 3.2.5 Test Result of Emission Bandwidth

Refer as Appendix B



### 3.3 Maximum Conducted Output Power

#### 3.3.1 Maximum Conducted Output Power Limit

| Maximum Conducted Output Power Limit  |  |
|---|--|
| <b>UNII Devices</b>   |  |
| <input checked="" type="checkbox"/> For the 5.15-5.25 GHz band:   |  |
|   | <ul style="list-style-type: none"> <li>▪ Outdoor AP: the maximum conducted output power (<math>P_{Out}</math>) shall not exceed the lesser of 1 W. If <math>G_{TX} &gt; 6</math> dBi, then <math>P_{Out} = 30 - (G_{TX} - 6)</math>. e.i.r.p. at any elevation angle above 30 degrees <math>\leq 125mW</math> [21dBm]</li> <li>▪ Indoor AP: the maximum conducted output power (<math>P_{Out}</math>) shall not exceed the lesser of 1 W. If <math>G_{TX} &gt; 6</math> dBi, then <math>P_{Out} = 30 - (G_{TX} - 6)</math></li> <li>▪ Point-to-point AP: the maximum conducted output power (<math>P_{Out}</math>) shall not exceed the lesser of 1 W. If <math>G_{TX} &gt; 23</math> dBi, then <math>P_{Out} = 30 - (G_{TX} - 23)</math>.</li> <li>▪ Mobile or Portable Client: the maximum conducted output power (<math>P_{Out}</math>) shall not exceed the lesser of 250 mW. If <math>G_{TX} &gt; 6</math> dBi, then <math>P_{Out} = 24 - (G_{TX} - 6)</math>.</li> </ul> |
| <input checked="" type="checkbox"/> For the 5.25-5.35 GHz band, the maximum conducted output power ( $P_{Out}$ ) shall not exceed the lesser of 250 mW or $11 \text{ dBm} + 10 \log B$ , where B is the 26 dB emission bandwidth in MHz. If $G_{TX} > 6$ dBi, then $P_{Out} = 24 - (G_{TX} - 6)$ .  |  |
| <input checked="" type="checkbox"/> For the 5.47-5.725 GHz band, the maximum conducted output power ( $P_{Out}$ ) shall not exceed the lesser of 250 mW or $11 \text{ dBm} + 10 \log B$ , where B is the 26 dB emission bandwidth in MHz. If $G_{TX} > 6$ dBi, then $P_{Out} = 24 - (G_{TX} - 6)$ . |  |
| <input checked="" type="checkbox"/> For the 5.725-5.85 GHz band:  |  |
|   | <ul style="list-style-type: none"> <li>▪ Point-to-multipoint systems (P2M): the maximum conducted output power (<math>P_{Out}</math>) shall not exceed the lesser of 1 W. If <math>G_{TX} &gt; 6</math> dBi, then <math>P_{Out} = 30 - (G_{TX} - 6)</math>.</li> <li>▪ Point-to-point systems (P2P): the maximum conducted output power (<math>P_{Out}</math>) shall not exceed the lesser of 1 W.</li> </ul>  |
| $P_{Out}$ = maximum conducted output power in dBm,<br>$G_{TX}$ = the maximum transmitting antenna directional gain in dBi.  |  |

### 3.3.2 Measuring Instruments

Refer a test equipment and calibration data table in this test report.

### 3.3.3 Test Procedures

| Test Method  |  |
|--|--|
| <ul style="list-style-type: none"> <li>Maximum Conducted Output Power</li> </ul> |  |
|  | Duty cycle $\geq 98\%$   |
| <input checked="" type="checkbox"/>  | Refer as KDB 789033, clause E Method SA-2 (spectral trace averaging).  |
|  | Duty cycle $< 98\%$  |
| <input type="checkbox"/>   | Refer as KDB 789033, clause E Method SA-2 Alt. (RMS detection with slow sweep speed)   |
| Wideband RF power meter and average over on/off periods with duty factor         |  |
| <input checked="" type="checkbox"/>  | Refer as KDB 789033, clause E Method PM (using an RF average power meter).   |
| <ul style="list-style-type: none"> <li>For conducted measurement.</li> </ul>     |  |
|  | <ul style="list-style-type: none"> <li>If the EUT supports multiple transmit chains using options given below:<br/>Refer as KDB 662911, In-band power measurements. Using the measure-and-sum approach, measured all transmit ports individually. Sum the power (in linear power units e.g., mW) of all ports for each individual sample and save them.</li> </ul> |
|  | <ul style="list-style-type: none"> <li>If multiple transmit chains, EIRP calculation could be following as methods:<br/> <math>P_{total} = P_1 + P_2 + \dots + P_n</math><br/>                     (calculated in linear unit [mW] and transfer to log unit [dBm])<br/> <math>EIRP_{total} = P_{total} + DG</math> </li> </ul>                                     |

### 3.3.4 Test Setup

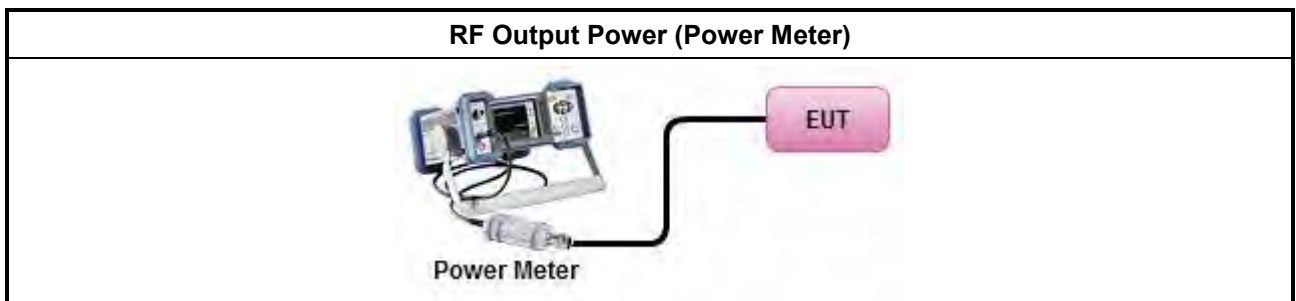
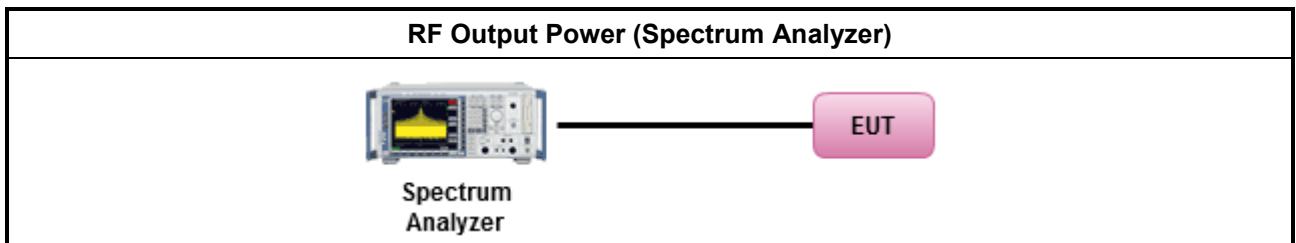

### 3.3.5 Test Result of Maximum Conducted Output Power

Refer as Appendix C

### 3.4 Peak Power Spectral Density

#### 3.4.1 Peak Power Spectral Density Limit

| Peak Power Spectral Density Limit  |  |
|--|--|
| <b>UNII Devices</b>  |  |
| <input checked="" type="checkbox"/> For the 5.15-5.25 GHz band:  |  |
|  | <ul style="list-style-type: none"> <li>▪ Outdoor AP: the peak power spectral density (PPSD) shall not exceed the lesser of 17dBm/MHz. If <math>G_{TX} &gt; 6</math> dBi, then <math>P_{Out} = 17 - (G_{TX} - 6)</math>.</li> <li>▪ Indoor AP: the peak power spectral density (PPSD) shall not exceed the lesser of 17dBm/MHz. If <math>G_{TX} &gt; 6</math> dBi, then <math>P_{Out} = 17 - (G_{TX} - 6)</math>.</li> <li>▪ Point-to-point AP: the peak power spectral density (PPSD) shall not exceed the lesser of 17dBm/MHz. If <math>G_{TX} &gt; 23</math> dBi, then <math>P_{Out} = 17 - (G_{TX} - 23)</math>.</li> <li>▪ Mobile or Portable Client: the peak power spectral density (PPSD) <math>\leq 11</math> dBm/MHz. If <math>G_{TX} &gt; 6</math> dBi, then <math>PPSD = 11 - (G_{TX} - 6)</math>.</li> </ul> |
| <input checked="" type="checkbox"/> For the 5.25-5.35 GHz band, the peak power spectral density (PPSD) $\leq 11$ dBm/MHz. If $G_{TX} > 6$ dBi, then $PPSD = 11 - (G_{TX} - 6)$ .   |  |
| <input checked="" type="checkbox"/> For the 5.47-5.725 GHz band, the peak power spectral density (PPSD) $\leq 11$ dBm/MHz. If $G_{TX} > 6$ dBi, then $PPSD = 11 - (G_{TX} - 6)$ .  |  |
| <input checked="" type="checkbox"/> For the 5.725-5.85 GHz band:   |  |
|  | <ul style="list-style-type: none"> <li>▪ Point-to-multipoint systems (P2M): the peak power spectral density (PPSD) <math>\leq 30</math> dBm/500kHz. If <math>G_{TX} &gt; 6</math> dBi, then <math>PPSD = 30 - (G_{TX} - 6)</math>.</li> <li>▪ Point-to-point systems (P2P): the peak power spectral density (PPSD) <math>\leq 30</math> dBm/500kHz.</li> </ul>   |
| <p><b>PPSD</b> = peak power spectral density that he same method as used to determine the conducted output power shall be used to determine the power spectral density. And power spectral density in dBm/MHz</p> <p><b>G<sub>TX</sub></b> = the maximum transmitting antenna directional gain in dBi.</p> |  |

#### 3.4.2 Measuring Instruments

Refer a test equipment and calibration data table in this test report.

### 3.4.3 Test Procedures

| Test Method   |  |
|---|--|
| <ul style="list-style-type: none"> <li>▪ Peak power spectral density procedures that the same method as used to determine the conducted output power shall be used to determine the peak power spectral density and use the peak search function on the spectrum analyzer to find the peak of the spectrum. For the peak power spectral density shall be measured using below options:</li> </ul> |  |
| <input type="checkbox"/>  | Refer as KDB 789033, F)5) power spectral density can be measured using resolution bandwidths < 1 MHz provided that the results are integrated over 1 MHz bandwidth   |
| Duty cycle ≥ 98%  |  |
| <input checked="" type="checkbox"/>   | Refer as KDB 789033, clause E Method SA-2 (spectral trace averaging).  |
| Duty cycle < 98%  |  |
| <input type="checkbox"/>  | Refer as KDB 789033, clause E Method SA-2 Alt. (RMS detection with slow sweep speed)   |
| <ul style="list-style-type: none"> <li>▪ For conducted measurement.</li> </ul>  |  |
| <ul style="list-style-type: none"> <li>▪ If the EUT supports multiple transmit chains using options given below:</li> </ul>   |  |
|   | <ul style="list-style-type: none"> <li>▪ Measure and sum the spectra across the outputs. Refer as KDB 662911, In-band power spectral density (PSD). Sample all transmit ports simultaneously using a spectrum analyzer for each transmit port. Where the trace bin-by-bin of each transmit port summing can be performed. (i.e., in the first spectral bin of output 1 is summed with that in the first spectral bin of output 2 and that from the first spectral bin of output 3, and so on up to the NTX output to obtain the value for the first frequency bin of the summed spectrum.). Add up the amplitude (power) values for the different transmit chains and use this as the new data trace.</li> </ul> |
|   | <ul style="list-style-type: none"> <li>▪ If multiple transmit chains, EIRP PPSD calculation could be following as methods:<br/> <math>PPSD_{total} = PPSD_1 + PPSD_2 + \dots + PPSD_n</math><br/>                     (calculated in linear unit [mW] and transfer to log unit [dBm])<br/> <math>EIRP_{total} = PPSD_{total} + DG</math> </li> </ul>   |

### 3.4.4 Test Setup

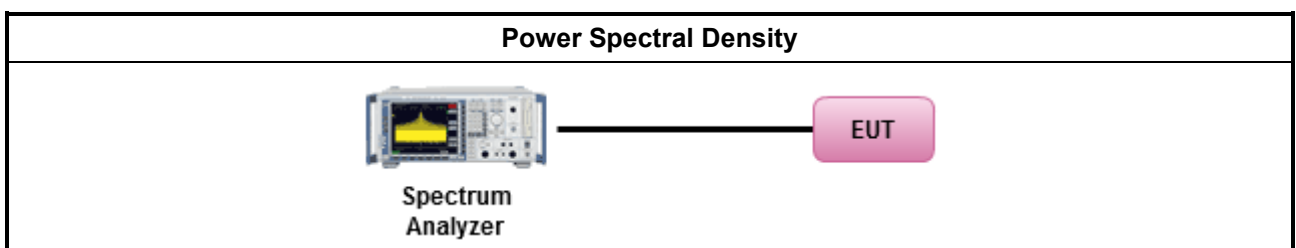

### 3.4.5 Test Result of Peak Power Spectral Density

Refer as Appendix D



### 3.5 Unwanted Emissions

#### 3.5.1 Transmitter Radiated Unwanted Emissions Limit

| Unwanted emissions below 1 GHz and restricted band emissions above 1GHz limit |                       |                         |                      |
|---|-----------------------|-------------------------|----------------------|
| Frequency Range (MHz)   | Field Strength (uV/m) | Field Strength (dBuV/m) | Measure Distance (m) |
| 0.009~0.490   | 2400/F(kHz)           | 48.5 - 13.8             | 300                  |
| 0.490~1.705   | 24000/F(kHz)          | 33.8 - 23               | 30                   |
| 1.705~30.0  | 30                    | 29                      | 30                   |
| 30~88   | 100                   | 40                      | 3                    |
| 88~216  | 150                   | 43.5                    | 3                    |
| 216~960   | 200                   | 46                      | 3                    |
| Above 960   | 500                   | 54                      | 3                    |

Note 1: Test distance for frequencies at or above 30 MHz, measurements may be performed at a distance other than the limit distance provided they are not performed in the near field and the emissions to be measured can be detected by the measurement equipment. When performing measurements at a distance other than that specified, the results shall be extrapolated to the specified distance using an extrapolation factor of 20 dB/decade (inverse of linear distance for field-strength measurements, inverse of linear distance-squared for power-density measurements).

Note 2: Test distance for frequencies at below 30 MHz, measurements may be performed at a distance closer than the EUT limit distance; however, an attempt should be made to avoid making measurements in the near field. When performing measurements below 30 MHz at a closer distance than the limit distance, the results shall be extrapolated to the specified distance by either making measurements at a minimum of two or more distances on at least one radial to determine the proper extrapolation factor or by using the square of an inverse linear distance extrapolation factor (40 dB/decade). The test report shall specify the extrapolation method used to determine compliance of the EUT.

Note 3: Using the distance of 1m during the test for above 18 GHz, and the test value to correct for the distance factor at 3m.



| Un-restricted band emissions above 1GHz Limit   |   |
|---|---|
| Operating Band  | Limit   |
| 5.15 - 5.25 GHz   | e.i.r.p. -27 dBm [68.2 dBuV/m@3m]   |
| 5.25 - 5.35 GHz   | e.i.r.p. -27 dBm [68.2 dBuV/m@3m]   |
| 5.47 - 5.725 GHz  | e.i.r.p. -27 dBm [68.2 dBuV/m@3m]   |
| 5.725 - 5.85 GHz  | 5.650-5700 GHz: e.i.r.p. -27 ~ 10 dBm [68.2 ~ 105.2 dBuV/m@3m]<br>5.700-5720 GHz: e.i.r.p. 10 ~ 15.6 dBm [105.2 ~ 110.8 dBuV/m@3m]<br>5.720-5725 GHz: e.i.r.p. 15.6 ~ 27 dBm [110.8 ~ 122.2 dBuV/m@3m]<br>5.850-5.855 GHz: e.i.r.p. 27 ~ 15.6 dBm [122.2 ~ 110.8 dBuV/m@3m]<br>5.855-5.875 GHz: e.i.r.p. 15.6 ~ 10 dBm [110.8 ~ 105.2 dBuV/m@3m]<br>5.875-5.925 GHz: e.i.r.p. 10 ~ -27 dBm [105.2 ~ 68.2dBuV/m@3m]<br>Other un-restricted band: e.i.r.p. -27 dBm [68.2 dBuV/m@3m] |
| Note 1: Measurements may be performed at a distance other than the limit distance provided they are not performed in the near field and the emissions to be measured can be detected by the measurement equipment. When performing measurements at a distance other than that specified, the results shall be extrapolated to the specified distance using an extrapolation factor of 20 dB/decade (inverse of linear distance for field-strength measurements, inverse of linear distance-squared for power-density measurements). |   |

### 3.5.2 Measuring Instruments

Refer a test equipment and calibration data table in this test report.

### 3.5.3 Test Procedures

| Test Method  |  |
|--|--|
| <ul style="list-style-type: none"> <li>▪ Measurements may be performed at a distance other than the limit distance provided they are not performed in the near field and the emissions to be measured can be detected by the measurement equipment. Measurements shall not be performed at a distance greater than 30 m for frequencies above 30 MHz, unless it can be further demonstrated that measurements at a distance of 30 m or less are impractical. When performing measurements at a distance other than that specified, the results shall be extrapolated to the specified distance using an extrapolation factor of 20 dB/decade (inverse of linear distance for field-strength measurements, inverse of linear distance-squared for power-density measurements).</li> </ul> |  |
| <ul style="list-style-type: none"> <li>▪ The average emission levels shall be measured in [duty cycle <math>\geq</math> 98 or duty factor].</li> </ul>   |  |
| <ul style="list-style-type: none"> <li>▪ For the transmitter unwanted emissions shall be measured using following options below:</li> </ul>  |  |
|  | <ul style="list-style-type: none"> <li>▪ Refer as KDB 789033, clause G)2) for unwanted emissions into non-restricted bands.</li> </ul>               |
|  | <ul style="list-style-type: none"> <li>▪ Refer as KDB 789033, clause G)1) for unwanted emissions into restricted bands.</li> </ul>                   |
|  | <input checked="" type="checkbox"/> Refer as KDB 789033, G)6) Method VB (ANSI C63.10, clause 4.1.4.2.3), Reduced VBW.                                |
|  | <input checked="" type="checkbox"/> Refer as KDB 789033, clause G)5) (ANSI C63.10, clause 4.1.4.2.2), measurement procedure peak limit.              |
| <ul style="list-style-type: none"> <li>▪ For radiated measurement.</li> </ul>  |  |
|  | <ul style="list-style-type: none"> <li>▪ Refer as ANSI C63.10, clause 6.4 for radiated emissions below 30 MHz and test distance is 3m.</li> </ul>    |
|  | <ul style="list-style-type: none"> <li>▪ Refer as ANSI C63.10, clause 6.5 for radiated emissions 30 MHz to 1 GHz and test distance is 3m.</li> </ul> |
|  | <ul style="list-style-type: none"> <li>▪ Refer as ANSI C63.10, clause 6.6 for radiated emissions above 1GHz.</li> </ul>                              |
| <ul style="list-style-type: none"> <li>▪ The any unwanted emissions level shall not exceed the fundamental emission level.</li> </ul>  |  |
| <ul style="list-style-type: none"> <li>▪ All amplitude of spurious emissions that are attenuated by more than 20 dB below the permissible value has no need to be reported.</li> </ul>   |  |

### 3.5.4 Test Setup

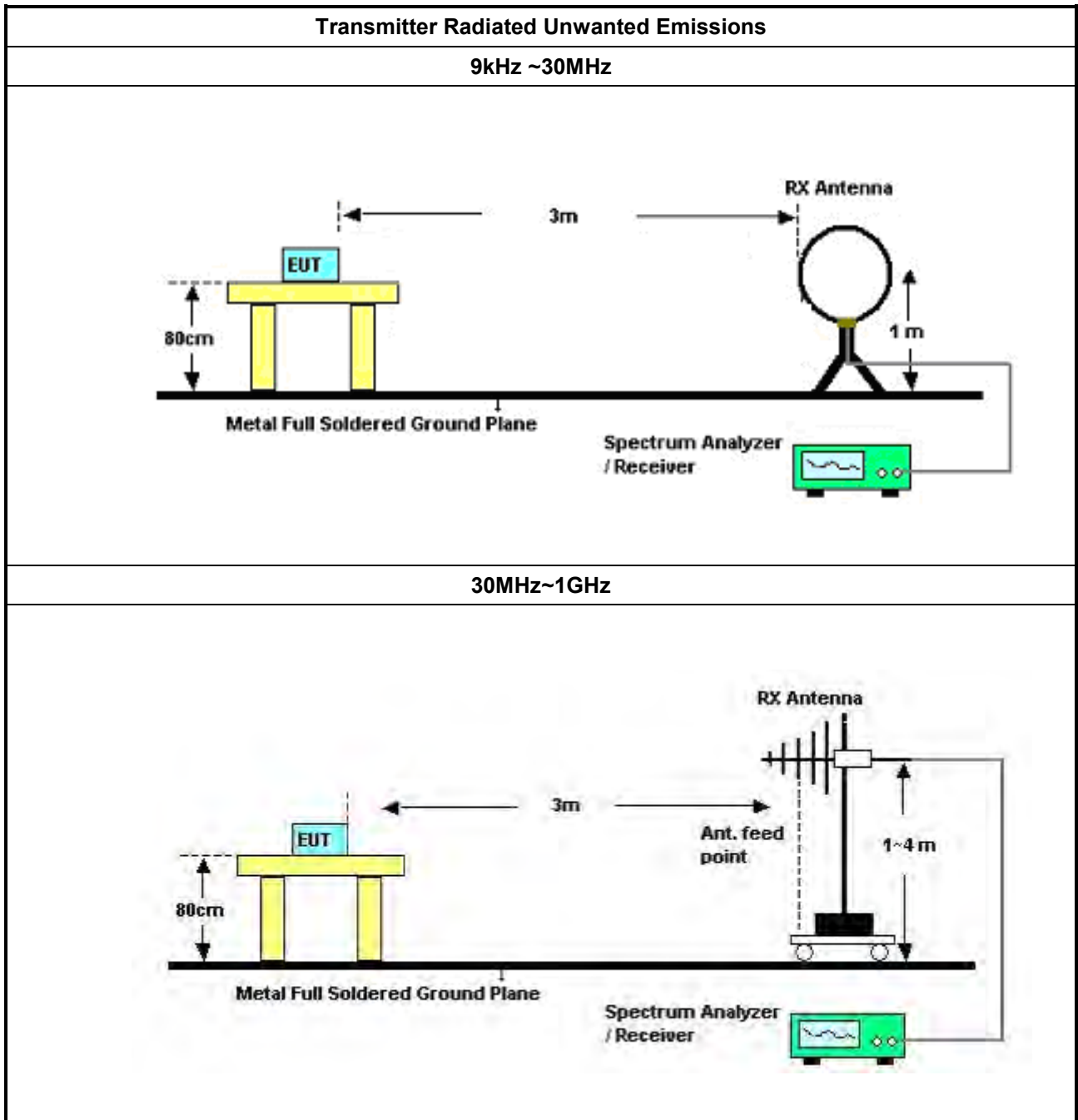



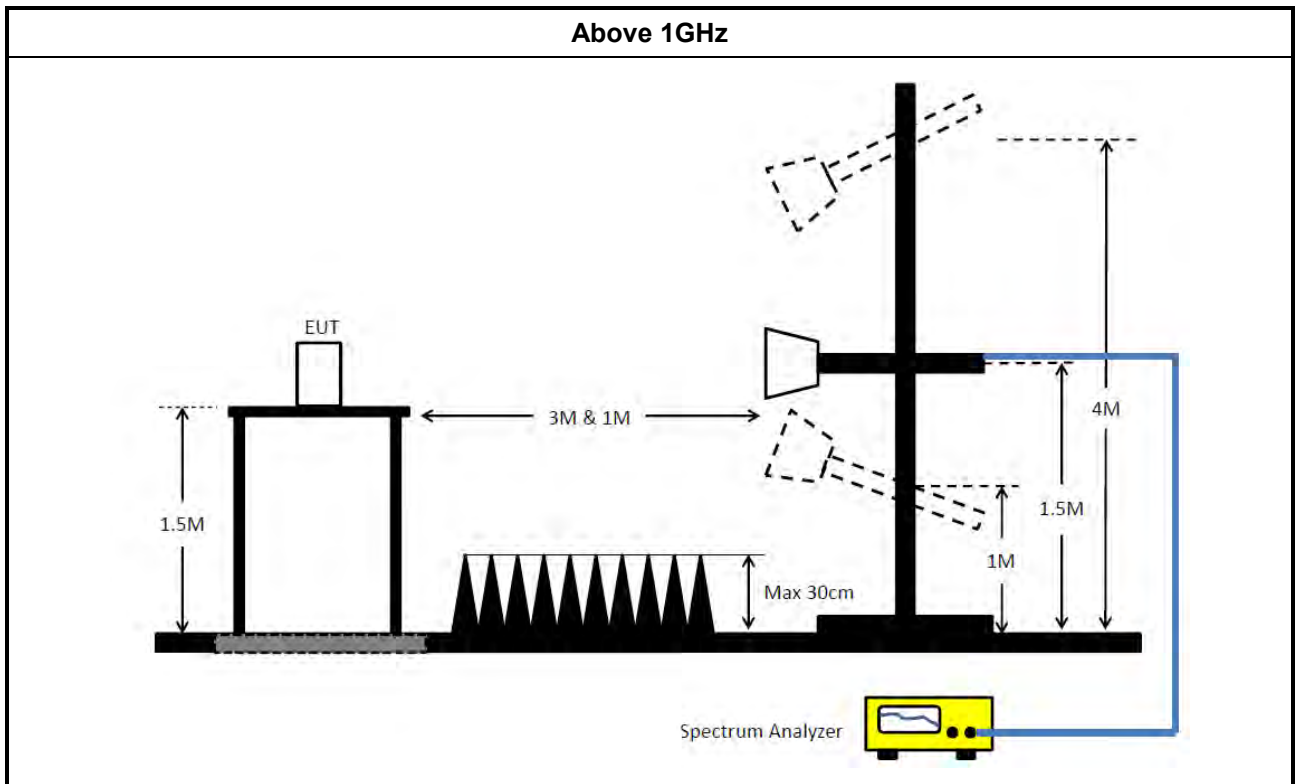



### **3.5.5 Transmitter Unwanted Emissions (Below 30MHz)**

The amplitude of spurious emissions which are attenuated by more than 20dB below the permissible value has no need to be reported.

### **3.5.6 Test Result of Transmitter Unwanted Emissions**

Refer as Appendix E



### 3.6 Test Equipment and Calibration Data

**Instrument for AC Conduction**

| Instrument                            | Manufacturer | Model No.   | Serial No.     | Spec.               | Calibration Date | Calibration Due Date |
|---------------------------------------|--------------|-------------|----------------|---------------------|------------------|----------------------|
| EMC Receiver                          | R&S          | ESR         | 102051         | 9KHz ~ 3.6GHz       | 03/May/2018      | 02/May/2019          |
| LISN                                  | R&S          | ENV216      | 101295         | 9kHz ~ 30MHz        | 17/Nov/2017      | 16/Nov/2018          |
| RF Cable-CON                          | HUBER+SUHNER | RG213/U     | 07611832020001 | 9kHz ~ 30MHz        | 06/Oct/2017      | 05/Oct/2018          |
| AC POWER                              | APC          | AFC-11005G  | F310050055     | 47Hz~63Hz<br>5~300V | NCR              | NCR                  |
| Impuls<br>Begrenzer Puls<br>e Limiter | SCHWARZBECK  | VTSD 9561-F | 9561-F041      | 9 kHz ~ 30 MHz      | 12/Oct/2017      | 11/Oct/2018          |

**NCR : Non-Calibration Require****Instrument for Conducted Test**

| Instrument        | Manufacturer | Model No.    | Serial No. | Spec.           | Calibration Date | Calibration Due Date |
|-------------------|--------------|--------------|------------|-----------------|------------------|----------------------|
| Spectrum Analyzer | R&S          | FSV 40       | 101515     | 9kHz~40GHz      | 08/Dec/2017      | 07/Dec/2018          |
| Power Sensor      | Anritsu      | MA2411B      | 1339407    | 300MHz ~ 40GHz  | 06/Nov/2017      | 05/Nov/2018          |
| Power Meter       | Anritsu      | ML2495A      | 1517010    | 300MHz ~ 40GHz  | 06/Nov/2017      | 05/Nov/2018          |
| RF Cable-0.2m     | HUBER+SUHNER | SUCOFLEX_104 | MY10710/4  | 30MHz ~ 26.5GHz | 25/Aug/2017      | 24/Aug/2018          |
| RF Cable-0.2m     | HUBER+SUHNER | SUCOFLEX_104 | MY10709/4  | 30MHz ~ 26.5GHz | 25/Aug/2017      | 24/Aug/2018          |
| RF Cable-0.5m     | HUBER+SUHNER | SUCOFLEX_104 | MY10713/4  | 30MHz ~ 26.5GHz | 25/Aug/2017      | 24/Aug/2018          |
| RF Cable-1m       | HUBER+SUHNER | SUCOFLEX_104 | MY37332/4  | 30MHz ~ 26.5GHz | 26/Jan/2018      | 25/Jan/2019          |
| RF Cable-1m       | HUBER+SUHNER | SUCOFLEX_104 | MY37333/4  | 30MHz ~ 26.5GHz | 26/Jan/2018      | 25/Jan/2019          |
| Signal Generator  | R&S          | SMR40        | 100116     | 10MHz ~ 40GHz   | 27/Jul/2017      | 26/Jul/2018          |



**Instrument for Radiated Test**

| Instrument                       | Manufacturer | Model No.             | Serial No.           | Spec.          | Calibration Date | Calibration Due Date |
|----------------------------------|--------------|-----------------------|----------------------|----------------|------------------|----------------------|
| 3m Semi Anechoic Chamber         | TDK          | SAC-3M                | 03CH09-HY            | 30MHz ~ 1GHz   | 23/Apr/2018      | 22/Apr/2019          |
| 3m Semi Anechoic Chamber         | TDK          | SAC-3M                | 03CH09-HY            | 1GHz ~ 18GHz   | 14/Jun/2018      | 13/Jun/2019          |
| Microwave Preamplifier           | Agilent      | 8449B                 | 3008A02096           | 1GHz ~ 26.5GHz | 10/May/2018      | 09/May/2019          |
| Amplifier                        | EMC          | EMC9135               | 980232               | 9KHz~1GHz      | 27/Apr/2018      | 26/Apr/2019          |
| EXA Signal Analyzer              | KEYSIGHT     | N9010A                | MY54200885           | 10Hz ~ 44GHz   | 20/Jul/2017      | 19/Jul/2018          |
| Bilog Antenna & 5dB Attenuator   | TESEQ & MTJ  | CBL6111D & MTJ6102-05 | 35418 / 3            | 30MHz~1GHz     | 09/Sep/2017      | 08/Sep/2018          |
| Double Ridged Guide Horn Antenna | SCHWARZBECK  | BBHA 9120 D           | BBHA9120 D 1534      | 1GHz~18GHz     | 30/Apr/2018      | 29/Apr/2019          |
| Broadband Horn Antenna           | SCHWARZBECK  | BBHA 9170             | BBHA9170614          | 18GHz~40GHz    | 09/Feb/2018      | 08/Feb/2019          |
| Preamplifier                     | MITEQ        | TTA1840-35-HG         | 1864481              | 18GHz ~ 40GHz  | 24/Aug/2017      | 23/Aug/2018          |
| Loop Antenna                     | TESEQ        | HLA 6120              | 31244                | 9k-30MHz       | 29/Mar/2018      | 28/Mar/2019          |
| RF Cable-R03m                    | Jye Bao      | RG142                 | CB031                | 9kHz ~ 1GHz    | 1/Feb/2018       | 31/Jan/2019          |
| RF Cable-high                    | HUBER+SUHNER | SUCOFLEX104           | SN 556626/4 + 556627 | 1GHz ~ 40GHz   | 14/Mar/2018      | 13/Mar/2019          |



AC Power-line Conducted Emissions Result

|                    |          |             |         |
|--------------------|----------|-------------|---------|
| Operating Mode     | 1        | Power Phase | Neutral |
| Operating Function | USB mode |             |         |

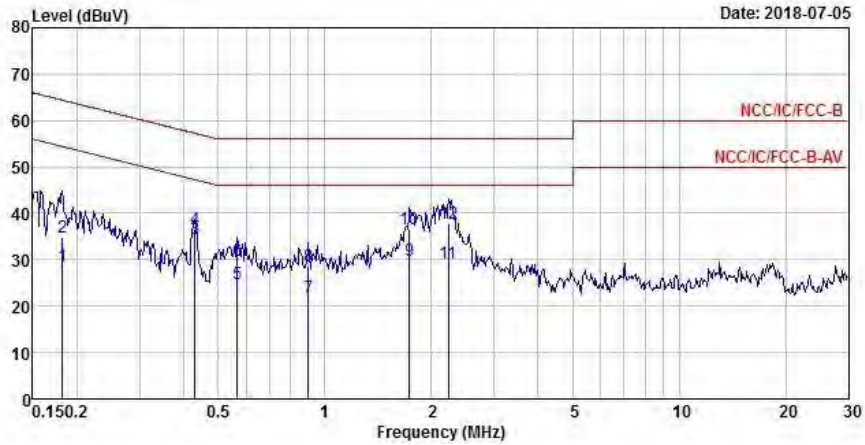

|    | Freq | Level | Over   | Limit  | Read  | LISM   | Cable | Remark       |
|----|------|-------|--------|--------|-------|--------|-------|--------------|
|    | MHz  | dBuV  | Limit  | Line   | Level | Factor | Loss  |              |
|    |      |       | dB     | dBuV   | dBuV  | dB     | dB    |              |
| 1  | 0.18 | 28.67 | -25.75 | 54.42  | 19.04 | 9.62   | 0.01  | Average      |
| 2  | 0.18 | 34.91 | -29.51 | 64.42  | 25.28 | 9.62   | 0.01  | QP           |
| 3  | MAX  | 0.43  | 34.65  | -12.59 | 47.24 | 24.95  | 9.61  | 0.09 Average |
| 4  | 0.43 | 36.56 | -20.68 | 57.24  | 26.86 | 9.61   | 0.09  | QP           |
| 5  | 0.57 | 24.87 | -21.13 | 46.00  | 15.20 | 9.61   | 0.06  | Average      |
| 6  | 0.57 | 29.92 | -26.08 | 56.00  | 20.25 | 9.61   | 0.06  | QP           |
| 7  | 0.90 | 21.84 | -24.16 | 46.00  | 12.21 | 9.62   | 0.01  | Average      |
| 8  | 0.90 | 28.66 | -27.34 | 56.00  | 19.03 | 9.62   | 0.01  | QP           |
| 9  | 1.73 | 29.81 | -16.19 | 46.00  | 20.18 | 9.63   | 0.00  | Average      |
| 10 | 1.73 | 36.56 | -19.44 | 56.00  | 26.93 | 9.63   | 0.00  | QP           |
| 11 | 2.24 | 29.11 | -16.89 | 46.00  | 19.47 | 9.63   | 0.01  | Average      |
| 12 | 2.24 | 37.66 | -18.34 | 56.00  | 28.02 | 9.63   | 0.01  | QP           |

Note 1: ">20dB" means emission levels that exceed the level of 20 dB below the applicable limit.  
 Note 2: "N/F" means Nothing Found emissions (No emissions were detected.)



AC Power-line Conducted Emissions Result

|                    |          |             |      |
|--------------------|----------|-------------|------|
| Operating Mode     | 1        | Power Phase | Line |
| Operating Function | USB mode |             |      |

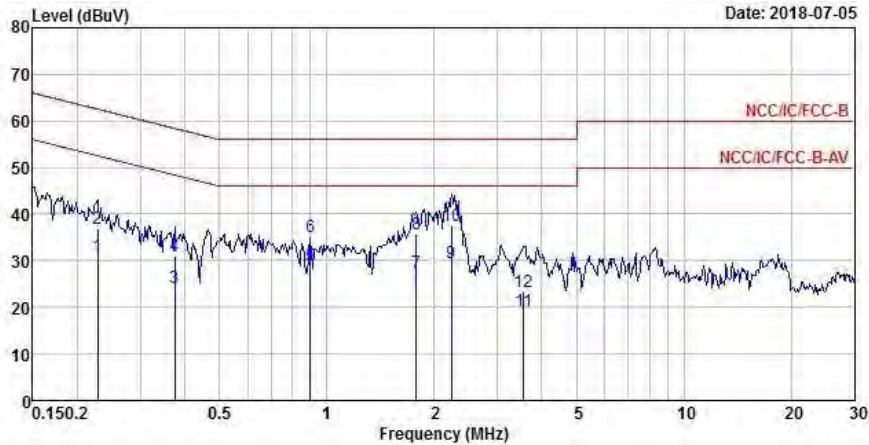

|       | Freq | Level | Over Limit | Limit Line | Read Level | LISN Factor | Cable Loss | Remark  |
|-------|------|-------|------------|------------|------------|-------------|------------|---------|
|       | MHz  | dBuV  | dB         | dBuV       | dBuV       | dB          | dB         |         |
| 1     | 0.23 | 31.02 | -21.50     | 52.52      | 21.38      | 9.62        | 0.02       | Average |
| 2     | 0.23 | 36.81 | -25.71     | 62.52      | 27.17      | 9.62        | 0.02       | QP      |
| 3     | 0.38 | 24.28 | -24.11     | 48.39      | 14.58      | 9.61        | 0.09       | Average |
| 4     | 0.38 | 30.89 | -27.50     | 58.39      | 21.19      | 9.61        | 0.09       | QP      |
| 5     | 0.90 | 28.85 | -17.15     | 46.00      | 19.23      | 9.61        | 0.01       | Average |
| 6     | 0.90 | 35.15 | -20.85     | 56.00      | 25.53      | 9.61        | 0.01       | QP      |
| 7     | 1.78 | 27.59 | -18.41     | 46.00      | 17.97      | 9.62        | 0.00       | Average |
| 8     | 1.78 | 35.68 | -20.32     | 56.00      | 26.06      | 9.62        | 0.00       | QP      |
| 9 MAX | 2.24 | 29.38 | -16.62     | 46.00      | 19.75      | 9.62        | 0.01       | Average |
| 10    | 2.24 | 37.58 | -18.42     | 56.00      | 27.95      | 9.62        | 0.01       | QP      |
| 11    | 3.57 | 19.32 | -26.68     | 46.00      | 9.62       | 9.63        | 0.07       | Average |
| 12    | 3.57 | 23.29 | -32.71     | 56.00      | 13.59      | 9.63        | 0.07       | QP      |

Note 1: ">20dB" means emission levels that exceed the level of 20 dB below the applicable limit.  
 Note 2: "N/F" means Nothing Found emissions (No emissions were detected.)

**Summary**

| Mode                           | Max-N dB<br>(Hz) | Max-OBW<br>(Hz) | ITU-Code | Min-N dB<br>(Hz) | Min-OBW<br>(Hz) |
|--------------------------------|------------------|-----------------|----------|------------------|-----------------|
| 5.15-5.25GHz                   | -                | -               | -        | -                | -               |
| 802.11a_Nss1,(6Mbps)_2TX       | 40.05M           | 19.765M         | 19M8D1D  | 38.65M           | 17.416M         |
| 802.11ac VHT20_Nss1,(MCS0)_2TX | 44.725M          | 19.865M         | 19M9D1D  | 25.95M           | 17.666M         |
| 802.11ac VHT40_Nss1,(MCS0)_2TX | 87.55M           | 37.131M         | 37M1D1D  | 44M              | 36.282M         |
| 802.11ac VHT80_Nss1,(MCS0)_2TX | 87.5M            | 75.862M         | 75M9D1D  | 83.6M            | 75.862M         |
| 5.25-5.35GHz                   | -                | -               | -        | -                | -               |
| 802.11a_Nss1,(6Mbps)_2TX       | 38.775M          | 18.666M         | 18M7D1D  | 20.575M          | 16.467M         |
| 802.11ac VHT20_Nss1,(MCS0)_2TX | 43.65M           | 18.791M         | 18M8D1D  | 43.1M            | 17.866M         |
| 802.11ac VHT40_Nss1,(MCS0)_2TX | 89.5M            | 38.331M         | 38M3D1D  | 43.2M            | 36.232M         |
| 802.11ac VHT80_Nss1,(MCS0)_2TX | 86M              | 75.862M         | 75M9D1D  | 83.6M            | 75.762M         |
| 5.47-5.725GHz                  | -                | -               | -        | -                | -               |
| 802.11a_Nss1,(6Mbps)_2TX       | 39.075M          | 18.516M         | 18M5D1D  | 20M              | 14.678M         |
| 802.11ac VHT20_Nss1,(MCS0)_2TX | 43M              | 19.165M         | 19M2D1D  | 21.375M          | 14.858M         |
| 802.11ac VHT40_Nss1,(MCS0)_2TX | 88.95M           | 38.481M         | 38M5D1D  | 43.6M            | 34.458M         |
| 802.11ac VHT80_Nss1,(MCS0)_2TX | 128.2M           | 76.162M         | 76M2D1D  | 83.2M            | 73.613M         |
| 5.725-5.85GHz                  | -                | -               | -        | -                | -               |
| 802.11a_Nss1,(6Mbps)_2TX       | 16.525M          | 19.165M         | 19M2D1D  | 3.2M             | 11.694M         |
| 802.11ac VHT20_Nss1,(MCS0)_2TX | 17.7M            | 19.69M          | 19M7D1D  | 3.82M            | 10.795M         |
| 802.11ac VHT40_Nss1,(MCS0)_2TX | 36.55M           | 40.73M          | 40M7D1D  | 3.28M            | 24.548M         |
| 802.11ac VHT80_Nss1,(MCS0)_2TX | 76.4M            | 82.259M         | 82M3D1D  | 3.2M             | 36.682M         |

**Max-N dB** = Maximum 6dB down bandwidth for 5.725-5.85GHz band / Maximum 26dB down bandwidth for other band;

**Max-OBW** = Maximum 99% occupied bandwidth;

**Min-N dB** = Minimum 6dB down bandwidth for 5.725-5.85GHz band / Maximum 26dB down bandwidth for other band;

**Min-OBW** = Minimum 99% occupied bandwidth;



**Result**

| Mode                                    | Result | Limit (Hz) | Port 1-N dB (Hz) | Port 1-OBW (Hz) | Port 2-N dB (Hz) | Port 2-OBW (Hz) |
|---|--------|------------|------------------|-----------------|------------------|-----------------|
| 802.11a_Nss1,(6Mbps)_2TX                | -      | -          | -                | -               | -                | -               |
| 5180MHz_TnomVnom                        | Pass   | Inf        | 40.05M           | 18.366M         | 40.05M           | 19.765M         |
| 5200MHz_TnomVnom                        | Pass   | Inf        | 39.05M           | 18.666M         | 38.975M          | 19.265M         |
| 5240MHz_TnomVnom                        | Pass   | Inf        | 38.65M           | 17.416M         | 39.175M          | 18.666M         |
| 5260MHz_TnomVnom                        | Pass   | Inf        | 38.75M           | 17.416M         | 38.775M          | 18.666M         |
| 5300MHz_TnomVnom                        | Pass   | Inf        | 38.45M           | 17.941M         | 38.575M          | 18.641M         |
| 5320MHz_TnomVnom                        | Pass   | Inf        | 20.575M          | 16.467M         | 22.95M           | 16.542M         |
| 5500MHz_TnomVnom                        | Pass   | Inf        | 20M              | 16.467M         | 24.175M          | 16.592M         |
| 5580MHz_TnomVnom                        | Pass   | Inf        | 38.775M          | 16.992M         | 39.075M          | 18.516M         |
| 5700MHz_TnomVnom                        | Pass   | Inf        | 25.325M          | 16.542M         | 26.125M          | 16.567M         |
| 5720MHz Straddle 5.47-5.725GHz_TnomVnom | Pass   | Inf        | 24.03M           | 14.888M         | 23.22M           | 14.678M         |
| 5720MHz Straddle 5.725-5.85GHz_TnomVnom | Pass   | 500k       | 3.22M            | 11.974M         | 3.2M             | 11.694M         |
| 5745MHz_TnomVnom                        | Pass   | 500k       | 16.45M           | 19.165M         | 16.525M          | 17.866M         |
| 5785MHz_TnomVnom                        | Pass   | 500k       | 16.475M          | 17.491M         | 16.525M          | 17.416M         |
| 5825MHz_TnomVnom                        | Pass   | 500k       | 16.45M           | 17.041M         | 16.525M          | 17.141M         |
| 802.11ac VHT20_Nss1,(MCS0)_2TX          | -      | -          | -                | -               | -                | -               |
| 5180MHz_TnomVnom                        | Pass   | Inf        | 25.95M           | 17.666M         | 29.8M            | 17.741M         |
| 5200MHz_TnomVnom                        | Pass   | Inf        | 43.425M          | 18.691M         | 44.725M          | 19.865M         |
| 5240MHz_TnomVnom                        | Pass   | Inf        | 43.15M           | 18.166M         | 43.225M          | 19.39M          |
| 5260MHz_TnomVnom                        | Pass   | Inf        | 43.5M            | 18.391M         | 43.65M           | 18.791M         |
| 5300MHz_TnomVnom                        | Pass   | Inf        | 43.425M          | 18.066M         | 43.425M          | 18.266M         |
| 5320MHz_TnomVnom                        | Pass   | Inf        | 43.1M            | 17.866M         | 43.175M          | 18.166M         |
| 5500MHz_TnomVnom                        | Pass   | Inf        | 21.375M          | 17.616M         | 26.125M          | 17.716M         |
| 5580MHz_TnomVnom                        | Pass   | Inf        | 42.325M          | 17.916M         | 43M              | 19.165M         |
| 5700MHz_TnomVnom                        | Pass   | Inf        | 21.55M           | 17.616M         | 21.9M            | 17.666M         |
| 5720MHz Straddle 5.47-5.725GHz_TnomVnom | Pass   | Inf        | 26.265M          | 14.903M         | 25.29M           | 14.858M         |
| 5720MHz Straddle 5.725-5.85GHz_TnomVnom | Pass   | 500k       | 3.82M            | 11.314M         | 3.82M            | 10.795M         |
| 5745MHz_TnomVnom                        | Pass   | 500k       | 17.7M            | 19.69M          | 17.7M            | 18.591M         |
| 5785MHz_TnomVnom                        | Pass   | 500k       | 17.675M          | 18.216M         | 17.7M            | 18.216M         |
| 5825MHz_TnomVnom                        | Pass   | 500k       | 17.7M            | 17.966M         | 17.7M            | 18.016M         |
| 802.11ac VHT40_Nss1,(MCS0)_2TX          | -      | -          | -                | -               | -                | -               |
| 5190MHz_TnomVnom                        | Pass   | Inf        | 44M              | 36.282M         | 44M              | 36.282M         |
| 5230MHz_TnomVnom                        | Pass   | Inf        | 87.55M           | 37.131M         | 87.1M            | 36.832M         |
| 5270MHz_TnomVnom                        | Pass   | Inf        | 89.1M            | 38.331M         | 89.5M            | 38.281M         |
| 5310MHz_TnomVnom                        | Pass   | Inf        | 43.2M            | 36.232M         | 43.7M            | 36.282M         |
| 5510MHz_TnomVnom                        | Pass   | Inf        | 43.6M            | 36.282M         | 55.55M           | 36.432M         |
| 5550MHz_TnomVnom                        | Pass   | Inf        | 87.6M            | 37.881M         | 88.95M           | 38.481M         |
| 5670MHz_TnomVnom                        | Pass   | Inf        | 73.7M            | 36.482M         | 70.05M           | 36.482M         |
| 5710MHz Straddle 5.47-5.725GHz_TnomVnom | Pass   | Inf        | 56.91M           | 34.458M         | 56.945M          | 34.633M         |
| 5710MHz Straddle 5.725-5.85GHz_TnomVnom | Pass   | 500k       | 3.28M            | 25.167M         | 3.28M            | 24.548M         |
| 5755MHz_TnomVnom                        | Pass   | 500k       | 36.4M            | 40.73M          | 36.55M           | 37.931M         |
| 5795MHz_TnomVnom                        | Pass   | 500k       | 36.5M            | 38.331M         | 36.45M           | 37.181M         |
| 802.11ac VHT80_Nss1,(MCS0)_2TX          | -      | -          | -                | -               | -                | -               |
| 5210MHz_TnomVnom                        | Pass   | Inf        | 87.5M            | 75.862M         | 83.6M            | 75.862M         |





| Mode                                    | Result | Limit (Hz) | Port 1-N dB (Hz) | Port 1-OBW (Hz) | Port 2-N dB (Hz) | Port 2-OBW (Hz) |
|---|--------|------------|------------------|-----------------|------------------|-----------------|
| 5290MHz_TnomVnom                        | Pass   | Inf        | 83.6M            | 75.762M         | 86M              | 75.862M         |
| 5530MHz_TnomVnom                        | Pass   | Inf        | 83.2M            | 75.862M         | 107.2M           | 75.862M         |
| 5610MHz_TnomVnom                        | Pass   | Inf        | 121.6M           | 76.062M         | 128.2M           | 76.162M         |
| 5690MHz Straddle 5.47-5.725GHz_TnomVnom | Pass   | Inf        | 118.05M          | 73.763M         | 117.75M          | 73.613M         |
| 5690MHz Straddle 5.725-5.85GHz_TnomVnom | Pass   | 500k       | 3.2M             | 37.081M         | 3.2M             | 36.682M         |
| 5775MHz_TnomVnom                        | Pass   | 500k       | 76.4M            | 82.259M         | 76.4M            | 76.962M         |

**Port X-N dB** = Port X 6dB down bandwidth for 5.725-5.85GHz band / 26dB down bandwidth for other band

**Port X-OBW** = Port X 99% occupied bandwidth;

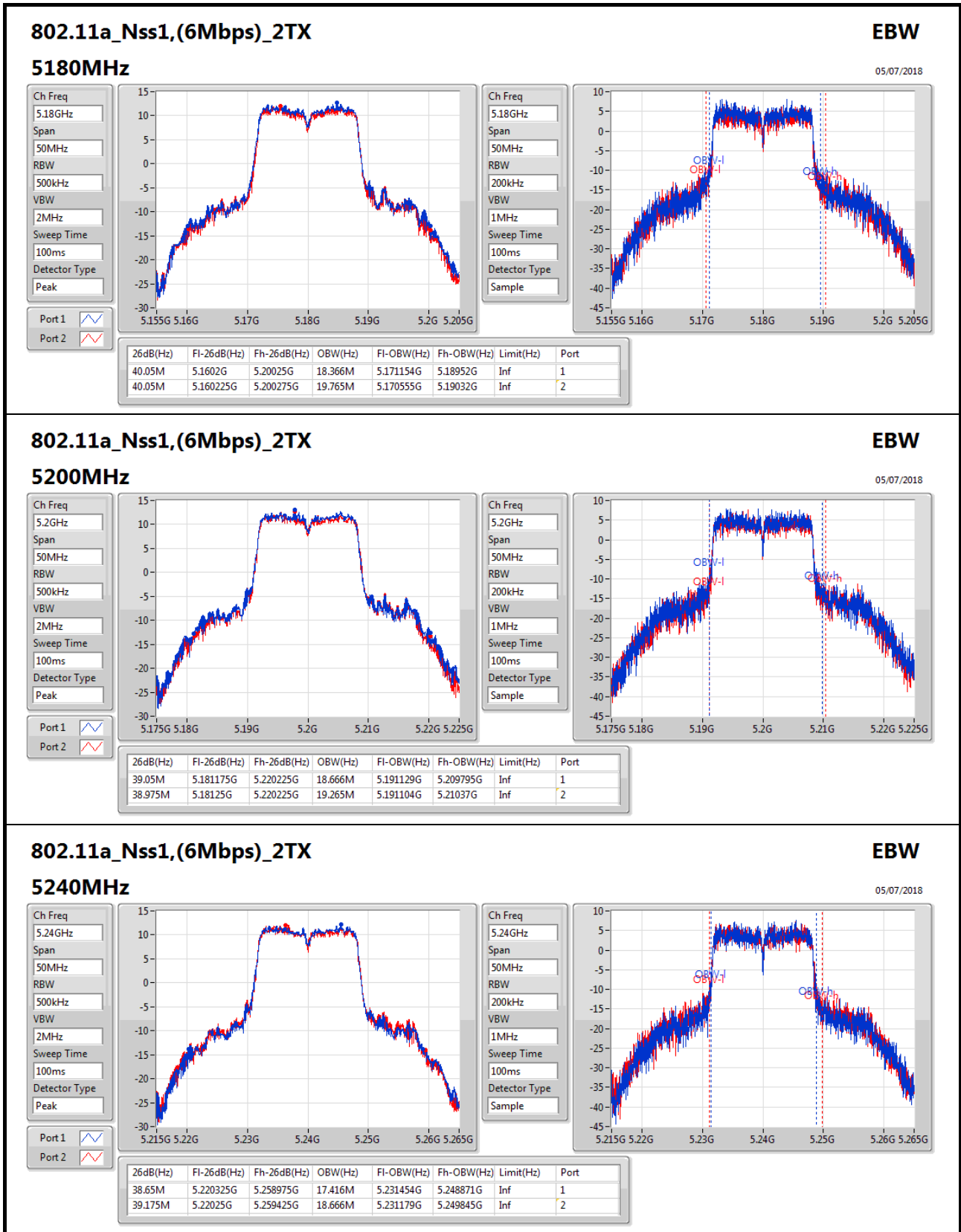

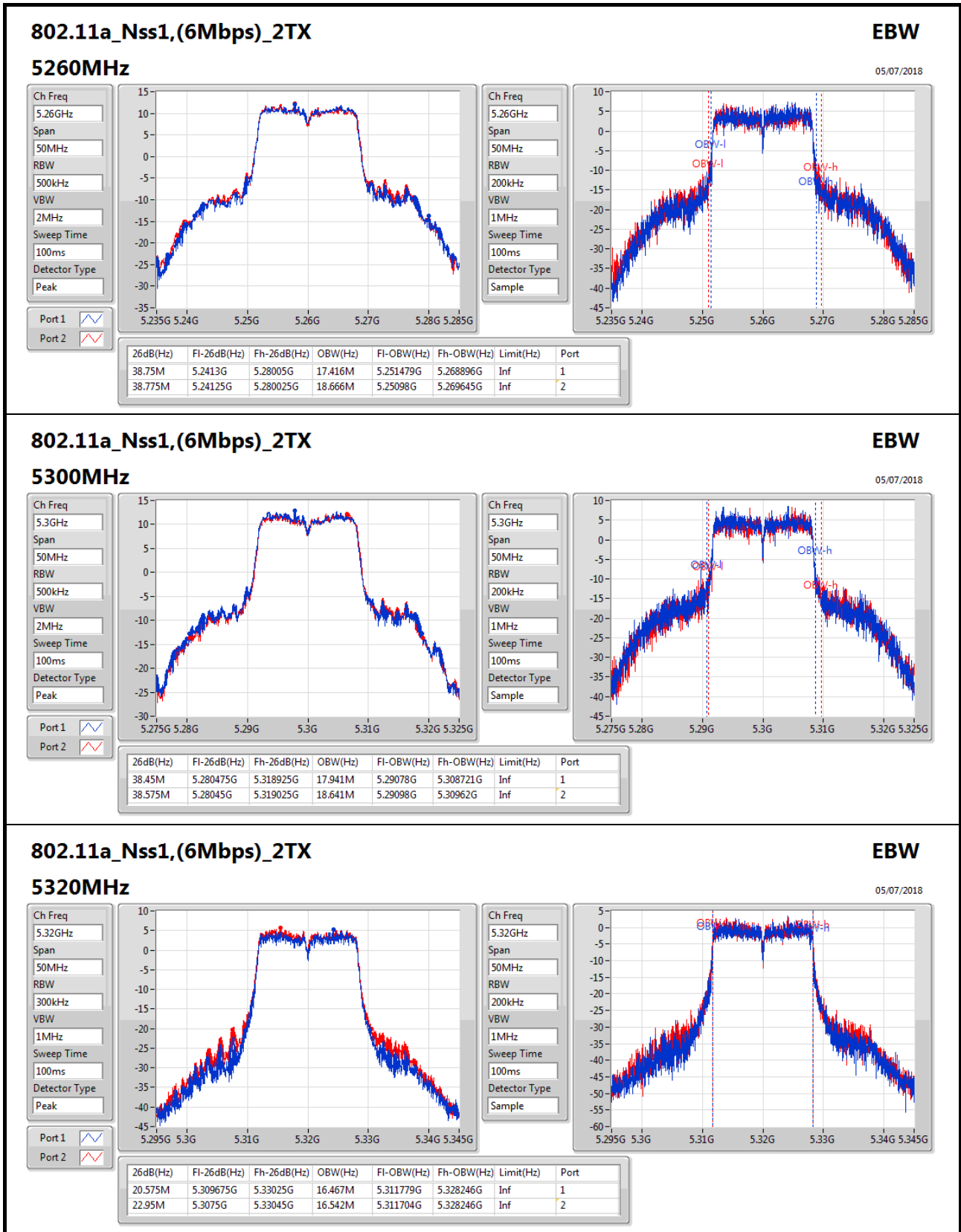

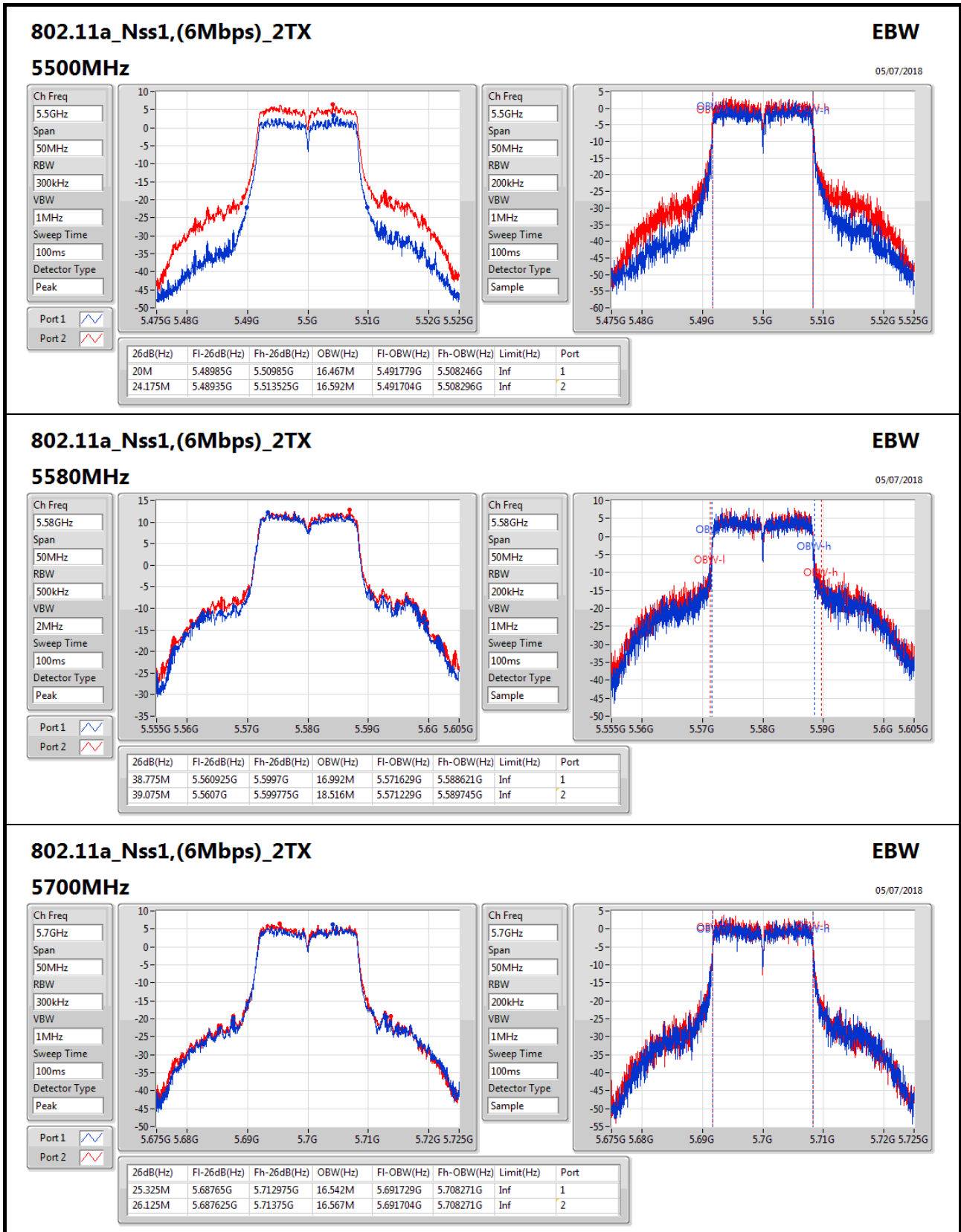

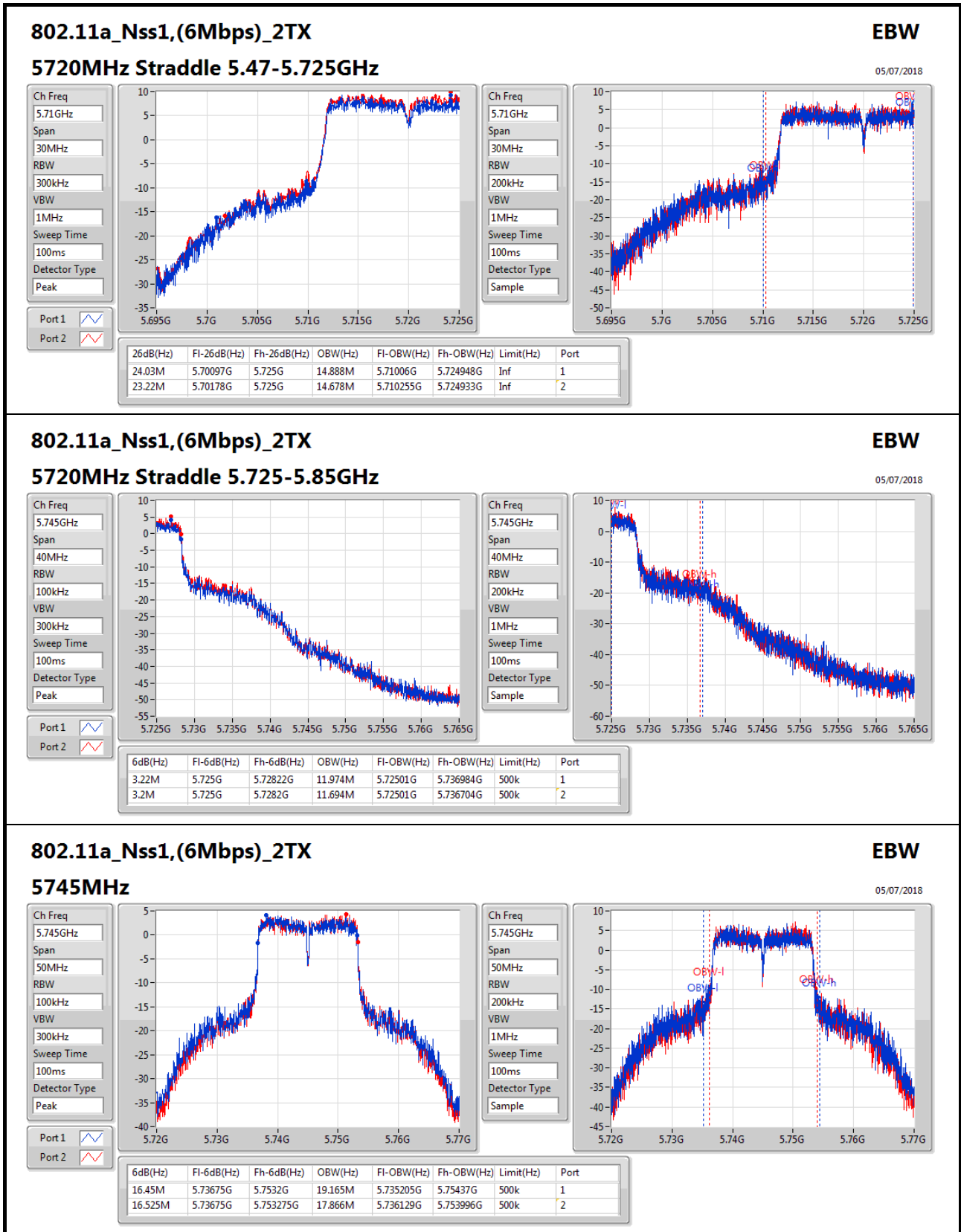

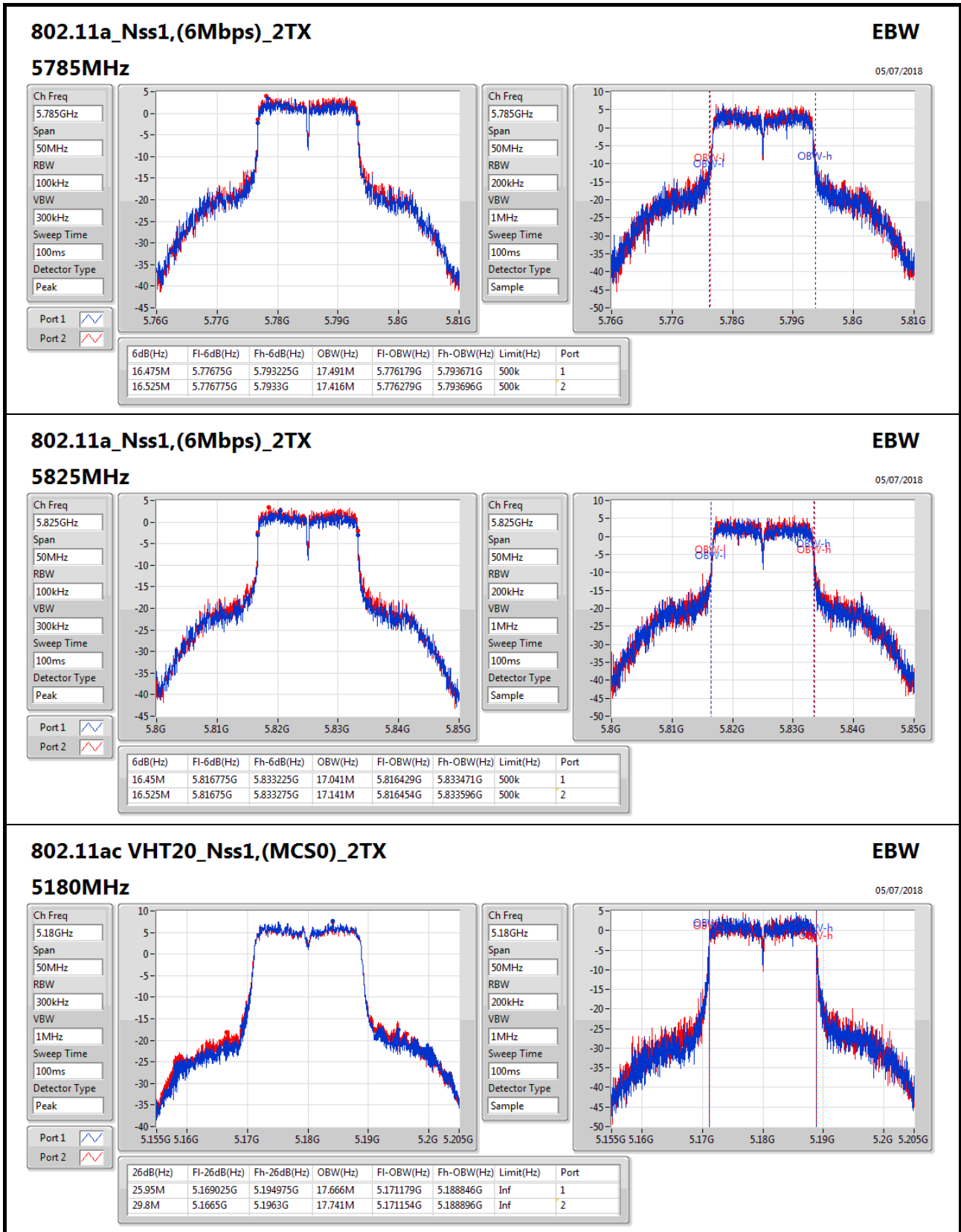

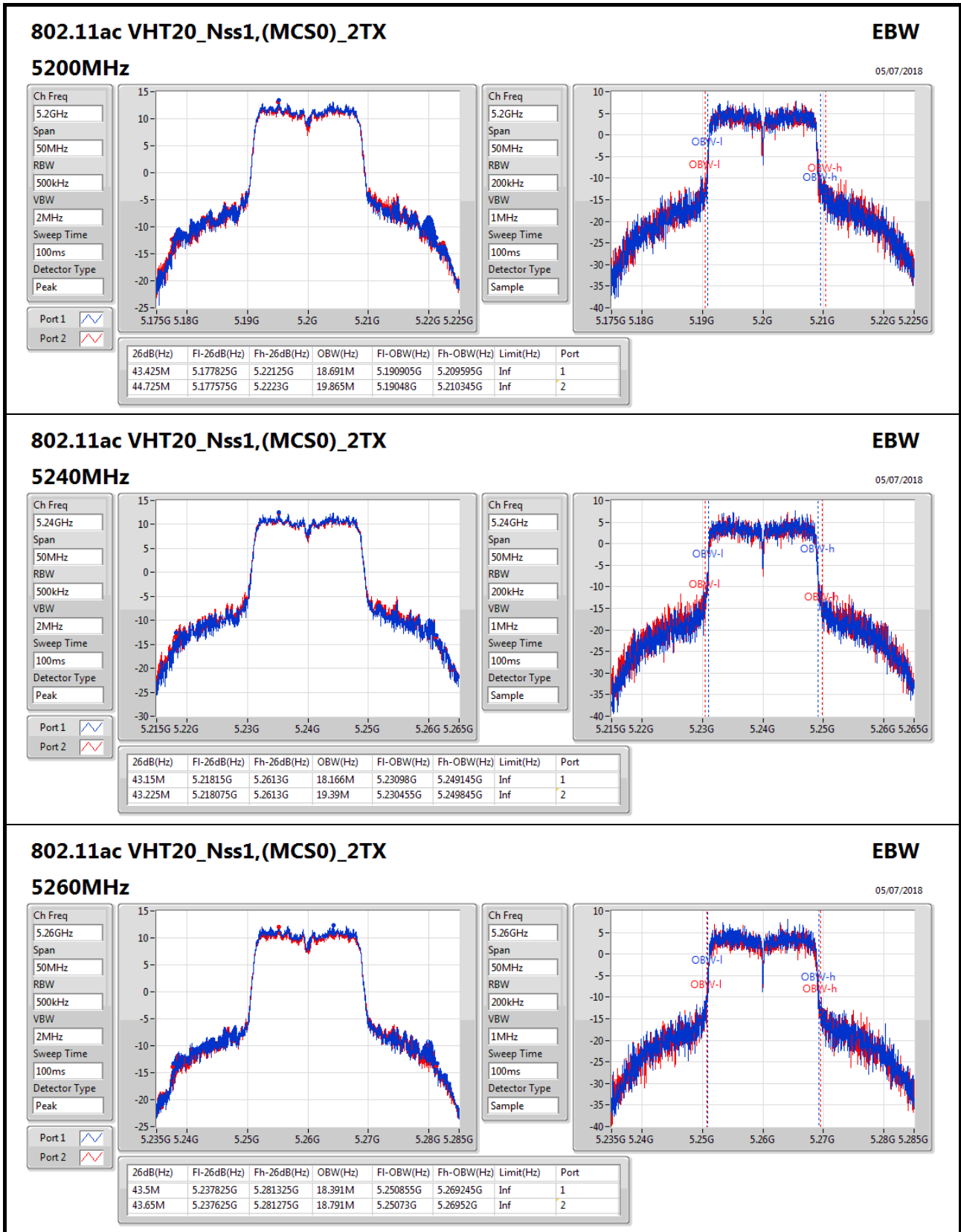

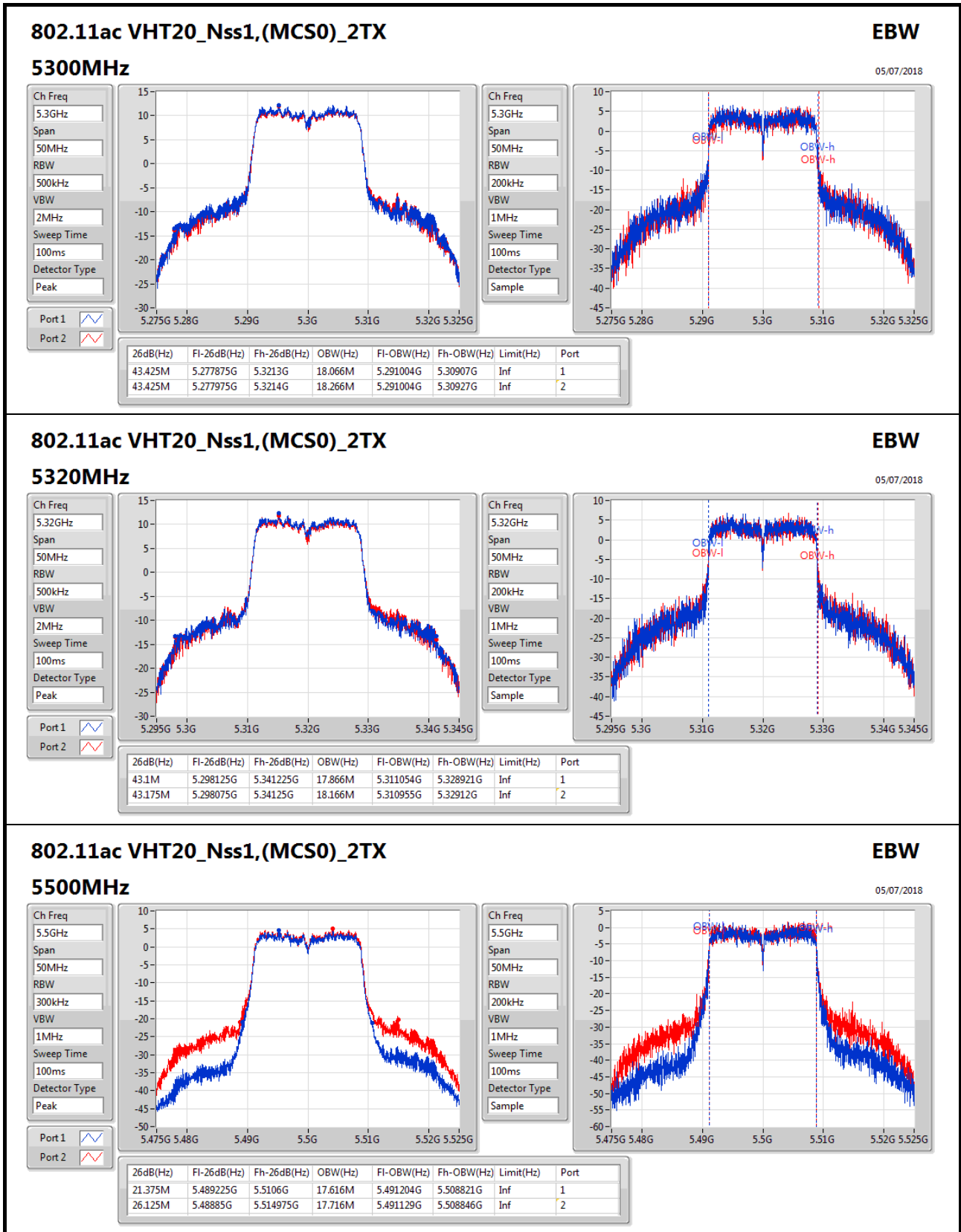



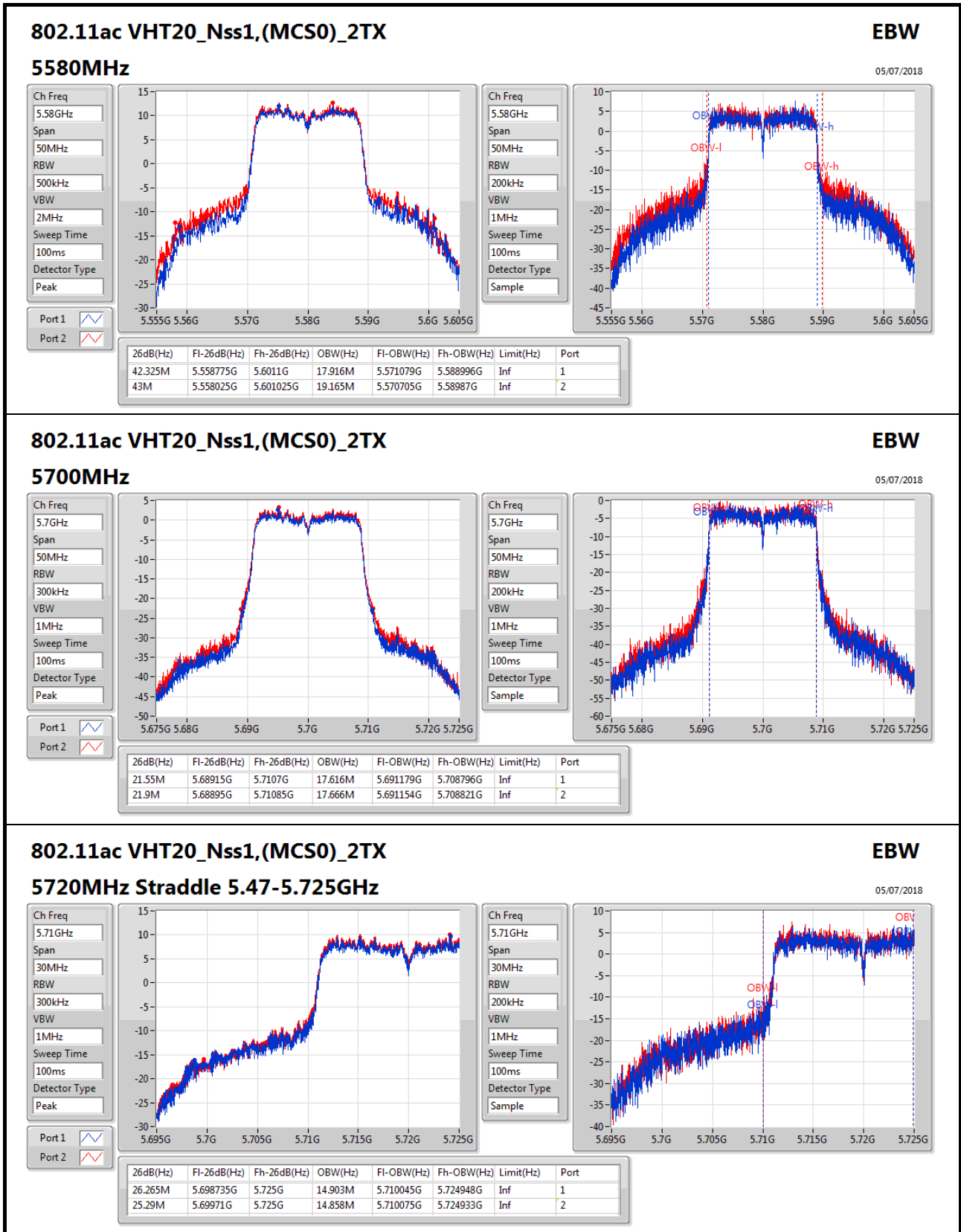

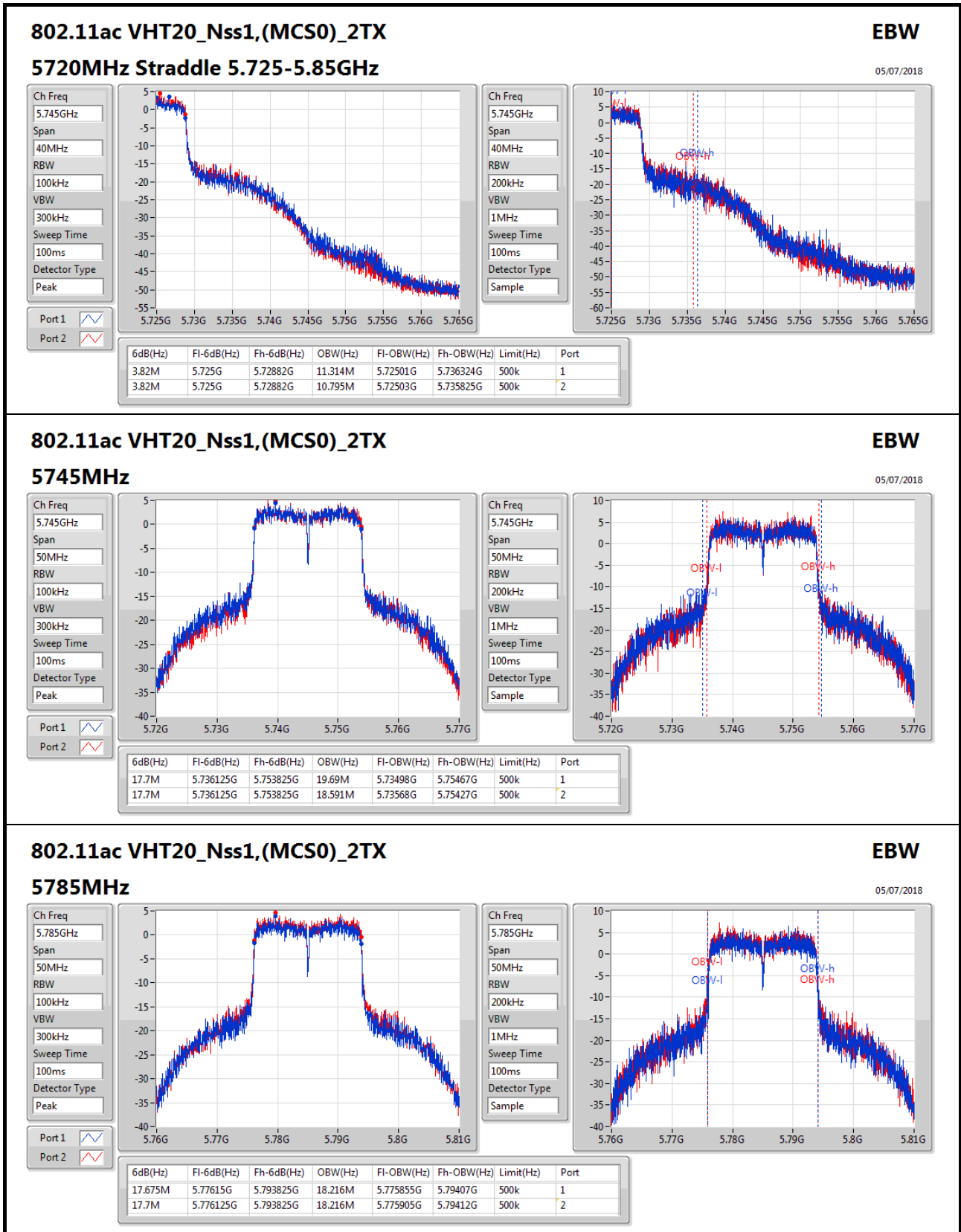

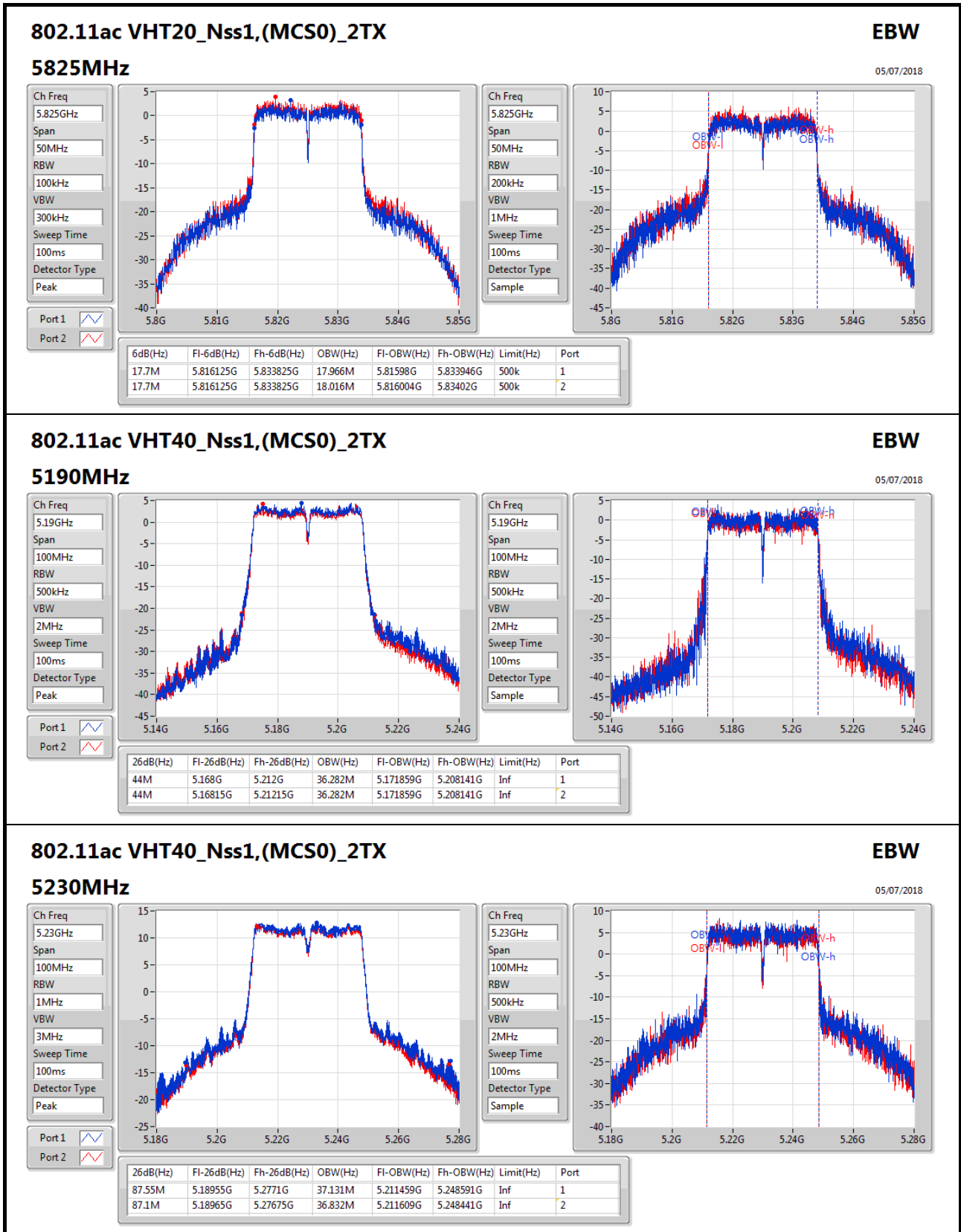

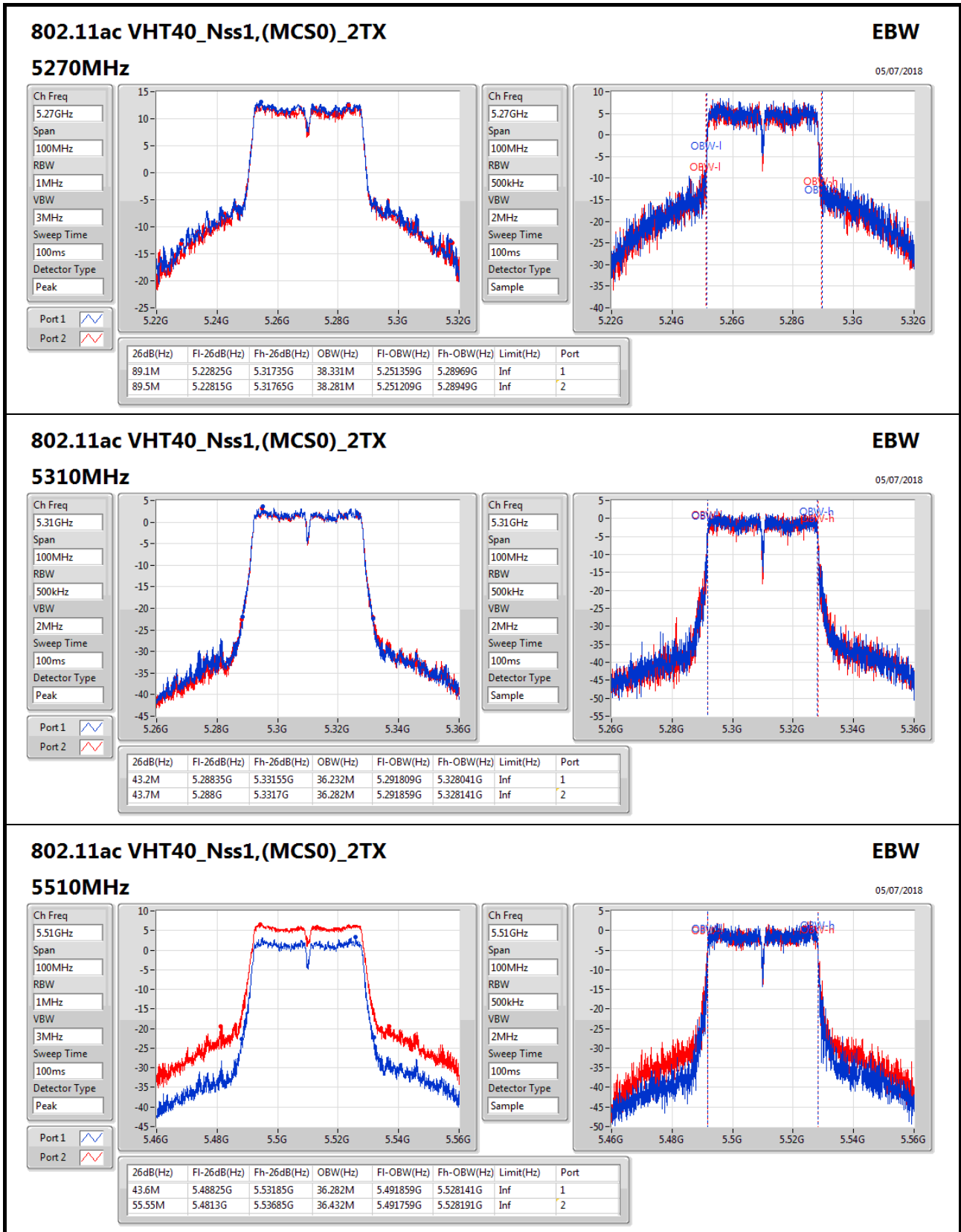

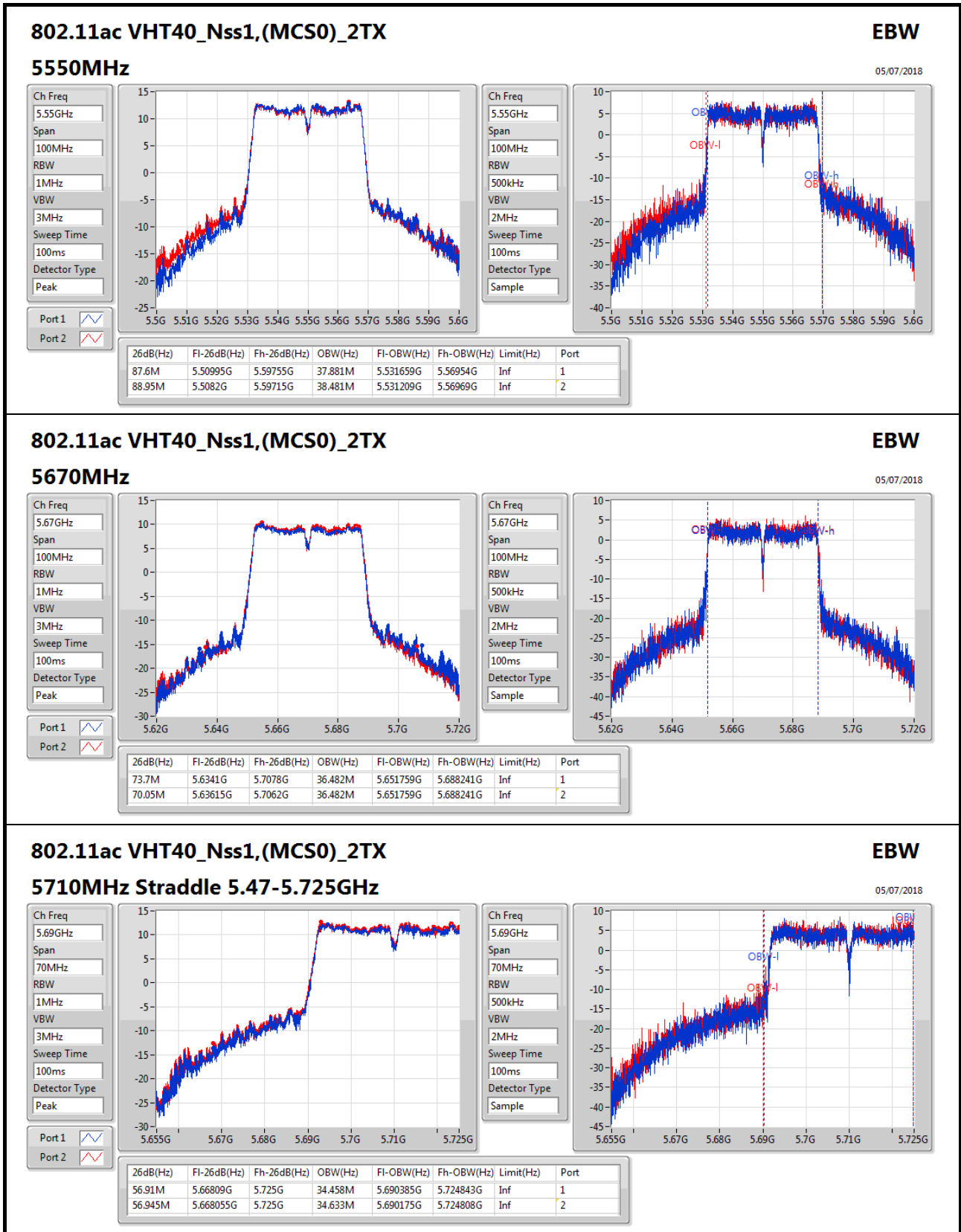

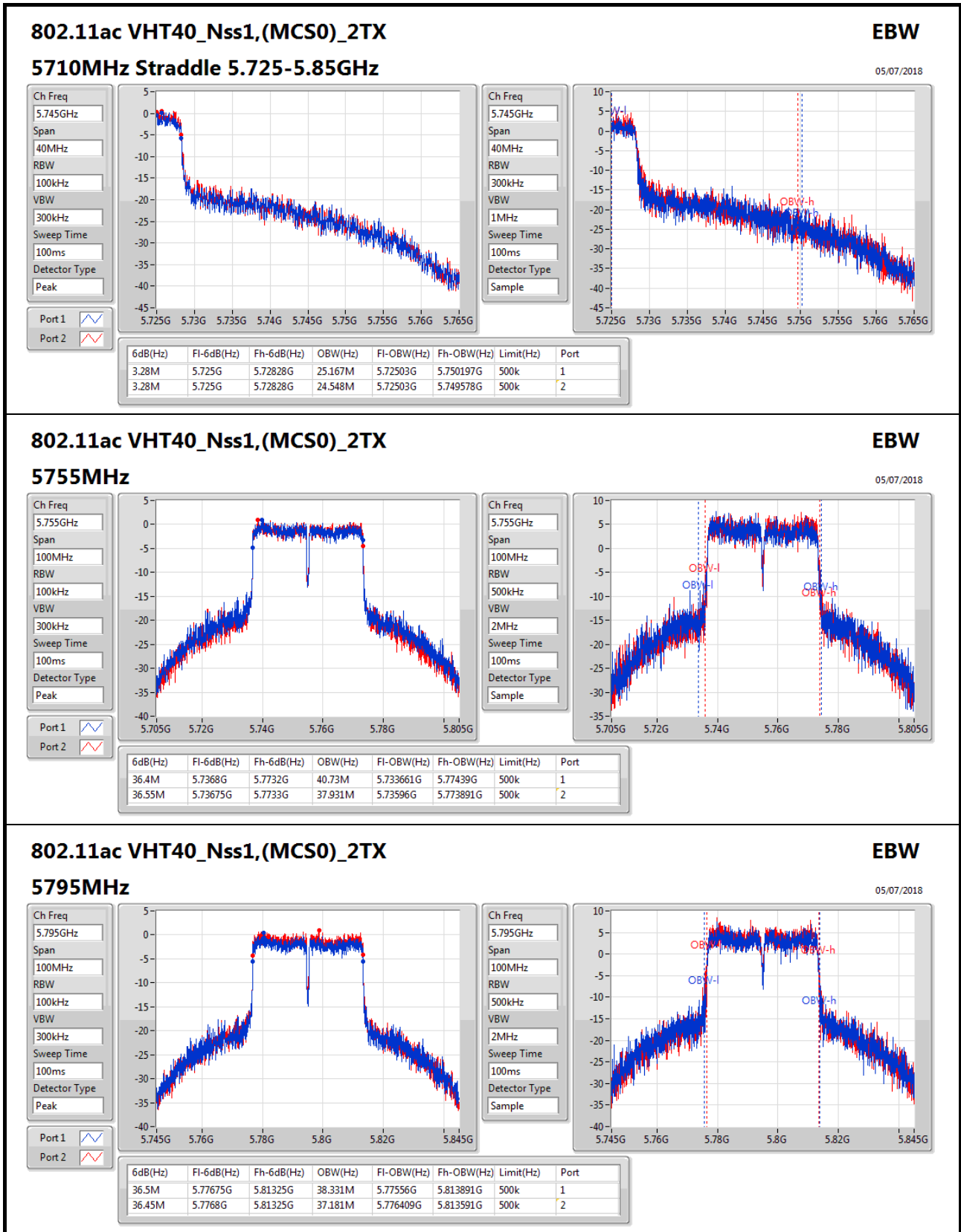

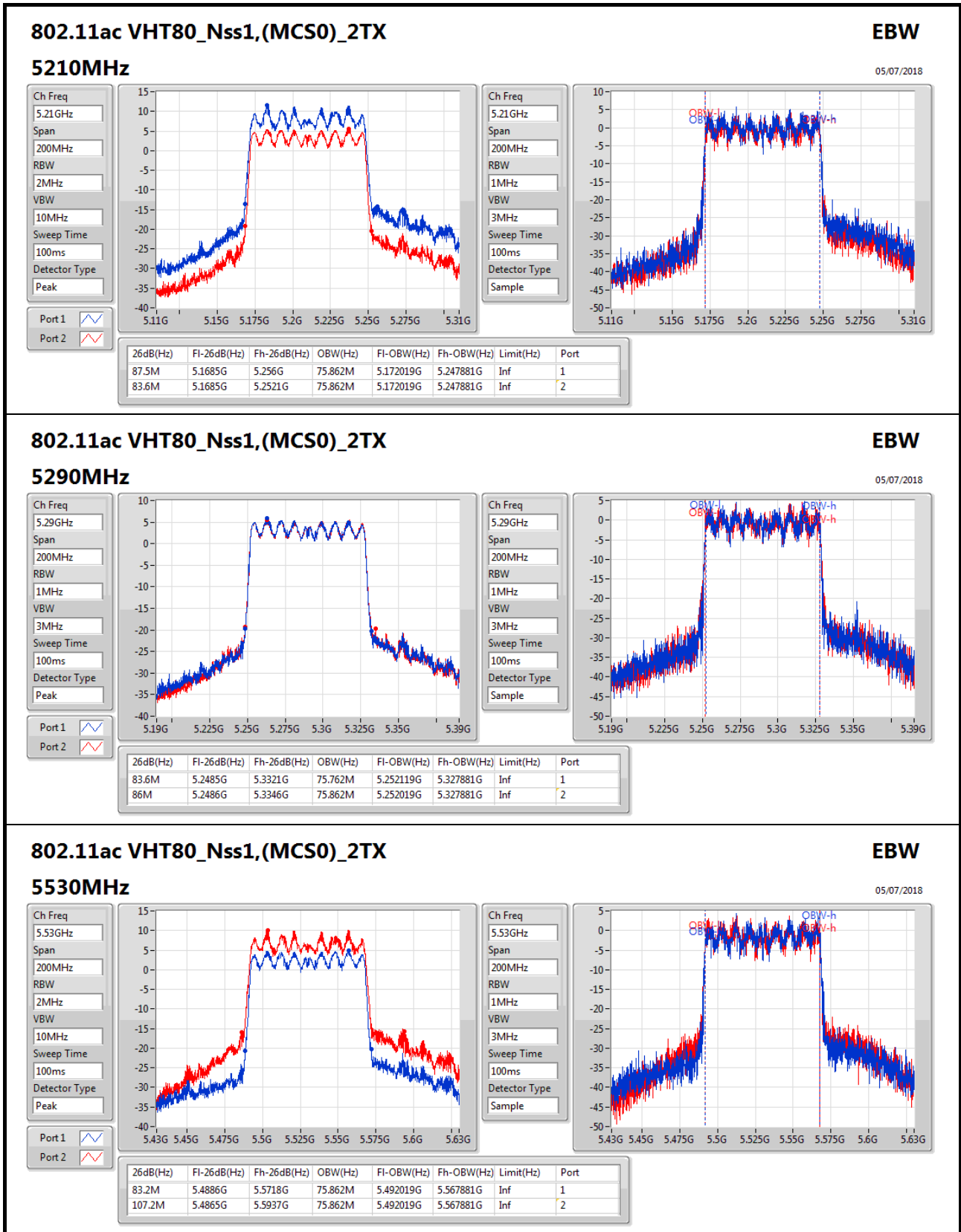



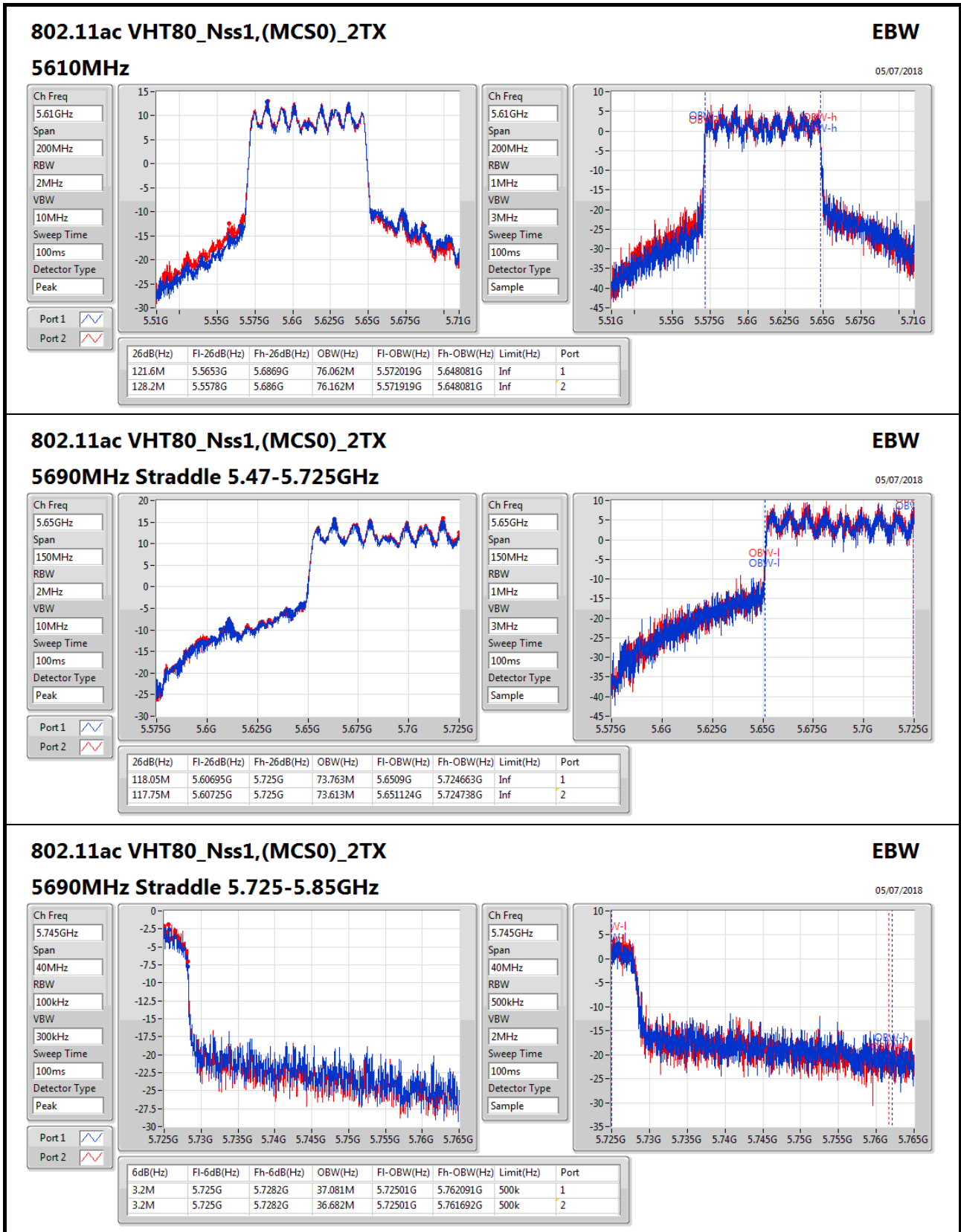



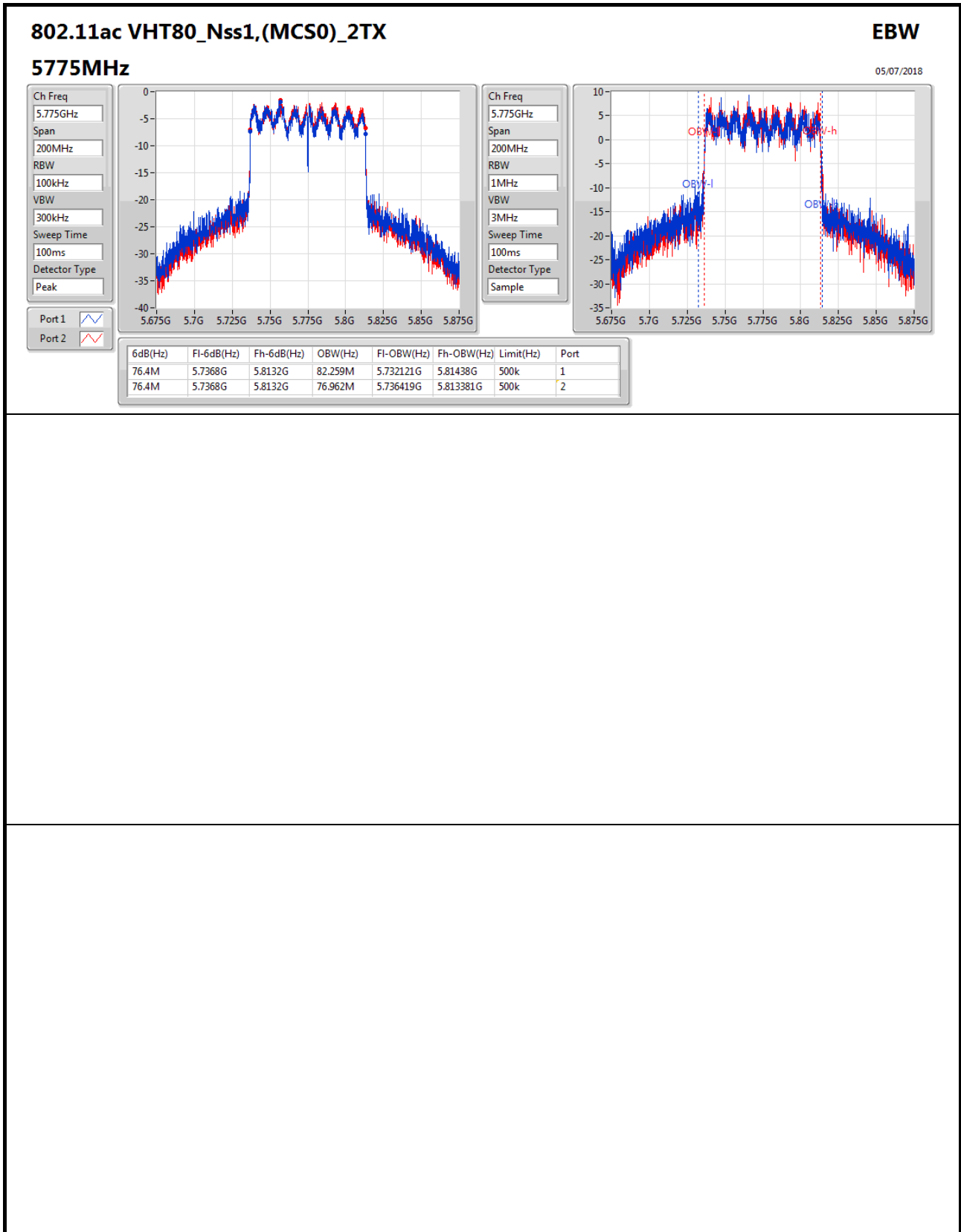



**Summary**

| Mode                           | Total Power<br>(dBm) | Total Power<br>(W) | EIRP<br>(dBm) | EIRP<br>(W) |
|--------------------------------|----------------------|--------------------|---------------|-------------|
| 5.15-5.25GHz                   | -                    | -                  | -             | -           |
| 802.11a_Nss1,(6Mbps)_2TX       | 22.67                | 0.18493            | 24.67         | 0.29309     |
| 802.11ac VHT20_Nss1,(MCS0)_2TX | 23.00                | 0.19953            | 25.00         | 0.31623     |
| 802.11ac VHT40_Nss1,(MCS0)_2TX | 21.58                | 0.14388            | 23.58         | 0.22803     |
| 802.11ac VHT80_Nss1,(MCS0)_2TX | 17.42                | 0.05521            | 19.42         | 0.08750     |
| 5.25-5.35GHz                   | -                    | -                  | -             | -           |
| 802.11a_Nss1,(6Mbps)_2TX       | 22.85                | 0.19275            | 24.85         | 0.30549     |
| 802.11ac VHT20_Nss1,(MCS0)_2TX | 22.23                | 0.16711            | 24.23         | 0.26485     |
| 802.11ac VHT40_Nss1,(MCS0)_2TX | 22.47                | 0.17660            | 24.47         | 0.27990     |
| 802.11ac VHT80_Nss1,(MCS0)_2TX | 17.13                | 0.05164            | 19.13         | 0.08185     |
| 5.47-5.725GHz                  | -                    | -                  | -             | -           |
| 802.11a_Nss1,(6Mbps)_2TX       | 21.86                | 0.15346            | 23.86         | 0.24322     |
| 802.11ac VHT20_Nss1,(MCS0)_2TX | 21.95                | 0.15668            | 23.95         | 0.24831     |
| 802.11ac VHT40_Nss1,(MCS0)_2TX | 22.00                | 0.15849            | 24.00         | 0.25119     |
| 802.11ac VHT80_Nss1,(MCS0)_2TX | 21.50                | 0.14125            | 23.50         | 0.22387     |
| 5.725-5.85GHz                  | -                    | -                  | -             | -           |
| 802.11a_Nss1,(6Mbps)_2TX       | 21.70                | 0.14791            | 23.70         | 0.23442     |
| 802.11ac VHT20_Nss1,(MCS0)_2TX | 21.98                | 0.15776            | 23.98         | 0.25003     |
| 802.11ac VHT40_Nss1,(MCS0)_2TX | 21.63                | 0.14555            | 23.63         | 0.23067     |
| 802.11ac VHT80_Nss1,(MCS0)_2TX | 21.31                | 0.13521            | 23.31         | 0.21429     |



**Result**

| Mode                                    | Result | DG (dBi) | Port 1 (dBm) | Port 2 (dBm) | Total Power (dBm) | Power Limit (dBm) | EIRP (dBm) | EIRP Limit (dBm) |
|---|--------|----------|--------------|--------------|-------------------|-------------------|------------|------------------|
| 802.11a_Nss1,(6Mbps)_2TX                | -      | -        | -            | -            | -                 | -                 | -          | -                |
| 5180MHz_TnomVnom                        | Pass   | 2.00     | 19.95        | 19.35        | 22.67             | 24.00             | 24.67      | 30.00            |
| 5200MHz_TnomVnom                        | Pass   | 2.00     | 19.68        | 19.21        | 22.46             | 24.00             | 24.46      | 30.00            |
| 5240MHz_TnomVnom                        | Pass   | 2.00     | 19.45        | 19.23        | 22.35             | 24.00             | 24.35      | 30.00            |
| 5260MHz_TnomVnom                        | Pass   | 2.00     | 20.09        | 19.57        | 22.85             | 24.00             | 24.85      | 30.00            |
| 5300MHz_TnomVnom                        | Pass   | 2.00     | 19.63        | 19.62        | 22.64             | 24.00             | 24.64      | 30.00            |
| 5320MHz_TnomVnom                        | Pass   | 2.00     | 14.73        | 15.01        | 17.88             | 24.00             | 19.88      | 30.00            |
| 5500MHz_TnomVnom                        | Pass   | 2.00     | 14.06        | 14.52        | 17.31             | 24.00             | 19.31      | 30.00            |
| 5580MHz_TnomVnom                        | Pass   | 2.00     | 18.53        | 19.14        | 21.86             | 24.00             | 23.86      | 30.00            |
| 5700MHz_TnomVnom                        | Pass   | 2.00     | 14.98        | 15.53        | 18.27             | 24.00             | 20.27      | 30.00            |
| 5720MHz Straddle 5.47-5.725GHz_TnomVnom | Pass   | 2.00     | 17.26        | 17.83        | 20.56             | 24.00             | 22.56      | 30.00            |
| 5720MHz Straddle 5.725-5.85GHz_TnomVnom | Pass   | 2.00     | 11.07        | 11.96        | 14.55             | 30.00             | 16.55      | 36.00            |
| 5745MHz_TnomVnom                        | Pass   | 2.00     | 18.60        | 18.78        | 21.70             | 30.00             | 23.70      | 36.00            |
| 5785MHz_TnomVnom                        | Pass   | 2.00     | 18.11        | 18.74        | 21.45             | 30.00             | 23.45      | 36.00            |
| 5825MHz_TnomVnom                        | Pass   | 2.00     | 17.53        | 18.23        | 20.90             | 30.00             | 22.90      | 36.00            |
| 802.11ac VHT20_Nss1,(MCS0)_2TX          | -      | -        | -            | -            | -                 | -                 | -          | -                |
| 5180MHz_TnomVnom                        | Pass   | 2.00     | 16.81        | 16.47        | 19.65             | 24.00             | 21.65      | 30.00            |
| 5200MHz_TnomVnom                        | Pass   | 2.00     | 20.12        | 19.85        | 23.00             | 24.00             | 25.00      | 30.00            |
| 5240MHz_TnomVnom                        | Pass   | 2.00     | 19.66        | 19.43        | 22.56             | 24.00             | 24.56      | 30.00            |
| 5260MHz_TnomVnom                        | Pass   | 2.00     | 19.47        | 18.95        | 22.23             | 24.00             | 24.23      | 30.00            |
| 5300MHz_TnomVnom                        | Pass   | 2.00     | 19.26        | 18.96        | 22.12             | 24.00             | 24.12      | 30.00            |
| 5320MHz_TnomVnom                        | Pass   | 2.00     | 19.09        | 18.76        | 21.94             | 24.00             | 23.94      | 30.00            |
| 5500MHz_TnomVnom                        | Pass   | 2.00     | 13.80        | 14.14        | 16.98             | 24.00             | 18.98      | 30.00            |
| 5580MHz_TnomVnom                        | Pass   | 2.00     | 18.58        | 19.27        | 21.95             | 24.00             | 23.95      | 30.00            |
| 5700MHz_TnomVnom                        | Pass   | 2.00     | 11.87        | 12.42        | 15.16             | 24.00             | 17.16      | 30.00            |
| 5720MHz Straddle 5.47-5.725GHz_TnomVnom | Pass   | 2.00     | 16.90        | 17.65        | 20.30             | 24.00             | 22.30      | 30.00            |
| 5720MHz Straddle 5.725-5.85GHz_TnomVnom | Pass   | 2.00     | 11.31        | 12.15        | 14.76             | 30.00             | 16.76      | 36.00            |
| 5745MHz_TnomVnom                        | Pass   | 2.00     | 18.88        | 19.01        | 21.96             | 30.00             | 23.96      | 36.00            |
| 5785MHz_TnomVnom                        | Pass   | 2.00     | 18.71        | 19.21        | 21.98             | 30.00             | 23.98      | 36.00            |
| 5825MHz_TnomVnom                        | Pass   | 2.00     | 17.78        | 18.39        | 21.11             | 30.00             | 23.11      | 36.00            |
| 802.11ac VHT40_Nss1,(MCS0)_2TX          | -      | -        | -            | -            | -                 | -                 | -          | -                |
| 5190MHz_TnomVnom                        | Pass   | 2.00     | 14.39        | 13.87        | 17.15             | 24.00             | 19.15      | 30.00            |
| 5230MHz_TnomVnom                        | Pass   | 2.00     | 18.77        | 18.36        | 21.58             | 24.00             | 23.58      | 30.00            |
| 5270MHz_TnomVnom                        | Pass   | 2.00     | 19.69        | 19.21        | 22.47             | 24.00             | 24.47      | 30.00            |
| 5310MHz_TnomVnom                        | Pass   | 2.00     | 14.56        | 14.40        | 17.49             | 24.00             | 19.49      | 30.00            |
| 5510MHz_TnomVnom                        | Pass   | 2.00     | 13.07        | 13.09        | 16.09             | 24.00             | 18.09      | 30.00            |
| 5550MHz_TnomVnom                        | Pass   | 2.00     | 18.88        | 19.10        | 22.00             | 24.00             | 24.00      | 30.00            |
| 5670MHz_TnomVnom                        | Pass   | 2.00     | 14.78        | 15.23        | 18.02             | 24.00             | 20.02      | 30.00            |
| 5710MHz Straddle 5.47-5.725GHz_TnomVnom | Pass   | 2.00     | 17.79        | 18.33        | 21.08             | 24.00             | 23.08      | 30.00            |
| 5710MHz Straddle 5.725-5.85GHz_TnomVnom | Pass   | 2.00     | 8.12         | 8.82         | 11.49             | 30.00             | 13.49      | 36.00            |
| 5755MHz_TnomVnom                        | Pass   | 2.00     | 18.45        | 18.79        | 21.63             | 30.00             | 23.63      | 36.00            |
| 5795MHz_TnomVnom                        | Pass   | 2.00     | 18.21        | 18.82        | 21.54             | 30.00             | 23.54      | 36.00            |
| 802.11ac VHT80_Nss1,(MCS0)_2TX          | -      | -        | -            | -            | -                 | -                 | -          | -                |
| 5210MHz_TnomVnom                        | Pass   | 2.00     | 14.71        | 14.09        | 17.42             | 24.00             | 19.42      | 30.00            |



| Mode                                    | Result | DG<br>(dBi) | Port 1<br>(dBm) | Port 2<br>(dBm) | Total Power<br>(dBm) | Power Limit<br>(dBm) | EIRP<br>(dBm) | EIRP Limit<br>(dBm) |
|---|--------|-------------|-----------------|-----------------|----------------------|----------------------|---------------|---------------------|
| 5290MHz_TnomVnom                        | Pass   | 2.00        | 14.12           | 14.11           | 17.13                | 24.00                | 19.13         | 30.00               |
| 5530MHz_TnomVnom                        | Pass   | 2.00        | 13.34           | 13.29           | 16.33                | 24.00                | 18.33         | 30.00               |
| 5610MHz_TnomVnom                        | Pass   | 2.00        | 16.18           | 16.40           | 19.30                | 24.00                | 21.30         | 30.00               |
| 5690MHz Straddle 5.47-5.725GHz_TnomVnom | Pass   | 2.00        | 18.28           | 18.69           | 21.50                | 24.00                | 23.50         | 30.00               |
| 5690MHz Straddle 5.725-5.85GHz_TnomVnom | Pass   | 2.00        | 5.35            | 6.08            | 8.74                 | 30.00                | 10.74         | 36.00               |
| 5775MHz_TnomVnom                        | Pass   | 2.00        | 18.09           | 18.50           | 21.31                | 30.00                | 23.31         | 36.00               |

DG = Directional Gain; Port X = Port X output power



802.11a\_Nss1,(6Mbps)\_2TX

AV Power

5720MHz Straddle 5.47-5.725GHz

05/07/2018

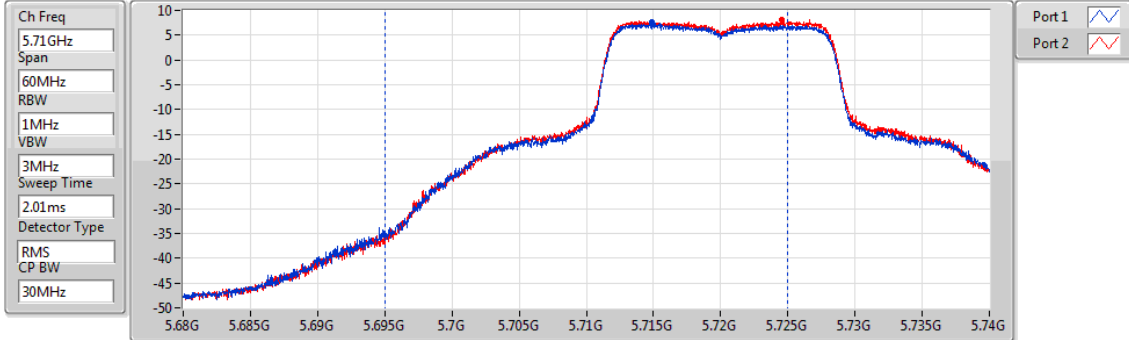

Sum=Total Power  
PX=Port X

| Sum(dBm) | P1(dBm) | P2(dBm) |
|----------|---------|---------|
| 20.56    | 17.26   | 17.83   |

802.11a\_Nss1,(6Mbps)\_2TX

AV Power

5720MHz Straddle 5.725-5.85GHz

05/07/2018

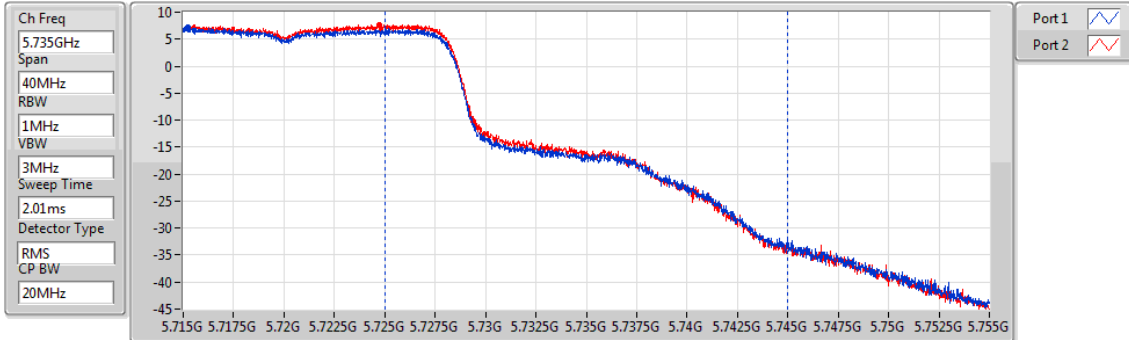

Sum=Total Power  
PX=Port X

| Sum(dBm) | P1(dBm) | P2(dBm) |
|----------|---------|---------|
| 14.55    | 11.07   | 11.96   |

802.11ac VHT20\_Nss1,(MCS0)\_2TX

AV Power

5720MHz Straddle 5.47-5.725GHz

05/07/2018

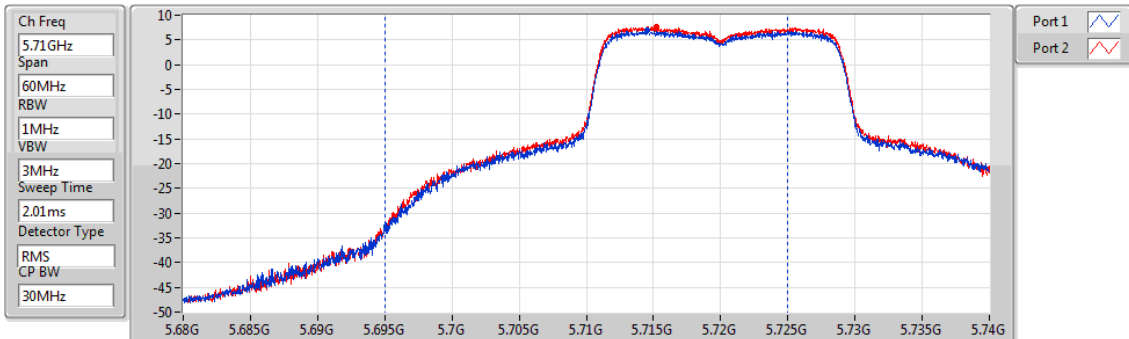

Sum=Total Power  
PX=Port X

| Sum(dBm) | P1(dBm) | P2(dBm) |
|----------|---------|---------|
| 20.30    | 16.90   | 17.65   |



802.11ac VHT20\_Nss1,(MCS0)\_2TX

AV Power

5720MHz Straddle 5.725-5.85GHz

05/07/2018

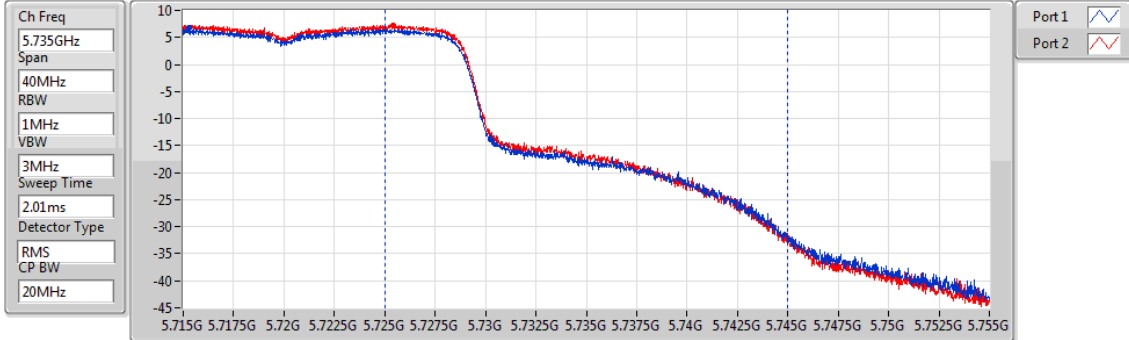

Sum=Total Power  
PX=Port X

| Sum(dBm) | P1(dBm) | P2(dBm) |
|----------|---------|---------|
| 14.76    | 11.31   | 12.15   |

802.11ac VHT40\_Nss1,(MCS0)\_2TX

AV Power

5710MHz Straddle 5.47-5.725GHz

05/07/2018

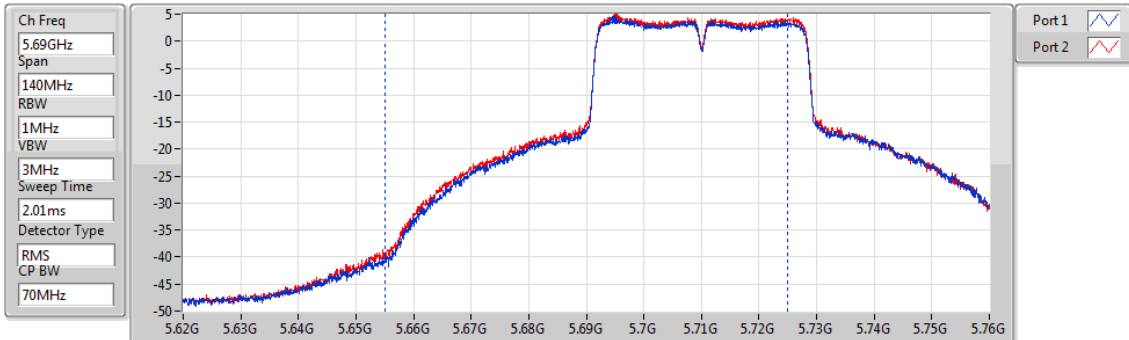

Sum=Total Power  
PX=Port X

| Sum(dBm) | P1(dBm) | P2(dBm) |
|----------|---------|---------|
| 21.08    | 17.79   | 18.33   |

802.11ac VHT40\_Nss1,(MCS0)\_2TX

AV Power

5710MHz Straddle 5.725-5.85GHz

05/07/2018

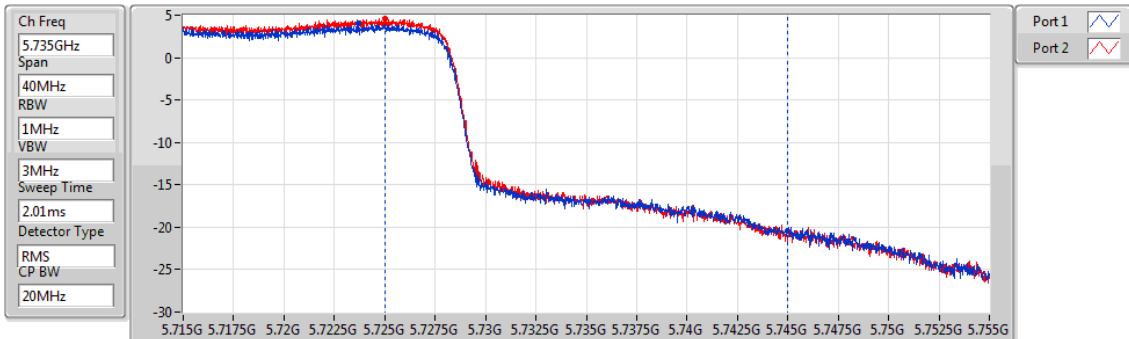

Sum=Total Power  
PX=Port X

| Sum(dBm) | P1(dBm) | P2(dBm) |
|----------|---------|---------|
| 11.49    | 8.12    | 8.82    |



802.11ac VHT80\_Nss1,(MCS0)\_2TX

AV Power

5690MHz Straddle 5.47-5.725GHz

05/07/2018

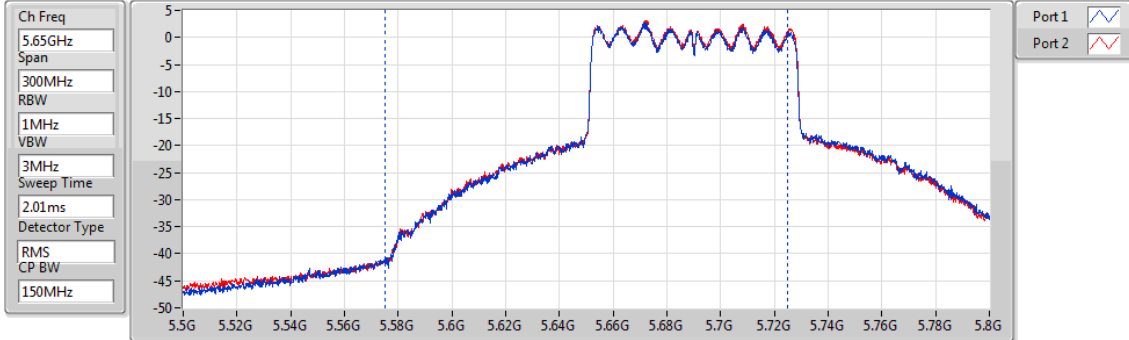

Sum=Total Power  
PX=Port X

| Sum(dBm) | P1(dBm) | P2(dBm) |
|----------|---------|---------|
| 21.50    | 18.28   | 18.69   |

802.11ac VHT80\_Nss1,(MCS0)\_2TX

AV Power

5690MHz Straddle 5.725-5.85GHz

05/07/2018

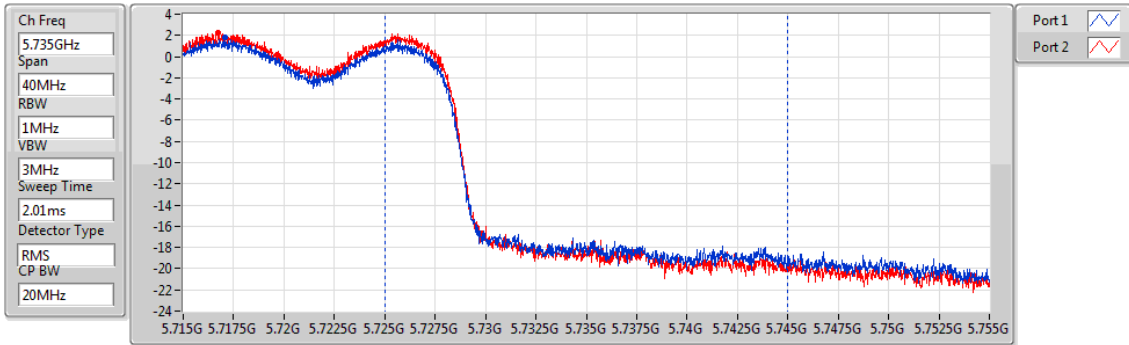

Sum=Total Power  
PX=Port X

| Sum(dBm) | P1(dBm) | P2(dBm) |
|----------|---------|---------|
| 8.74     | 5.35    | 6.08    |



Summary

| Mode                           | PD<br>(dBm/RBW) | EIRP PD<br>(dBm/RBW) |
|--------------------------------|-----------------|----------------------|
| 5.15-5.25GHz                   | -               | -                    |
| 802.11a_Nss1,(6Mbps)_2TX       | 10.36           | 15.37                |
| 802.11ac VHT20_Nss1,(MCS0)_2TX | 10.00           | 15.01                |
| 802.11ac VHT40_Nss1,(MCS0)_2TX | 5.81            | 10.82                |
| 802.11ac VHT80_Nss1,(MCS0)_2TX | -0.57           | 4.44                 |
| 5.25-5.35GHz                   | -               | -                    |
| 802.11a_Nss1,(6Mbps)_2TX       | 9.78            | 14.79                |
| 802.11ac VHT20_Nss1,(MCS0)_2TX | 9.14            | 14.15                |
| 802.11ac VHT40_Nss1,(MCS0)_2TX | 6.13            | 11.14                |
| 802.11ac VHT80_Nss1,(MCS0)_2TX | -0.68           | 4.33                 |
| 5.47-5.725GHz                  | -               | -                    |
| 802.11a_Nss1,(6Mbps)_2TX       | 9.29            | 14.30                |
| 802.11ac VHT20_Nss1,(MCS0)_2TX | 9.28            | 14.29                |
| 802.11ac VHT40_Nss1,(MCS0)_2TX | 6.09            | 11.10                |
| 802.11ac VHT80_Nss1,(MCS0)_2TX | 3.84            | 8.85                 |
| 5.725-5.85GHz                  | -               | -                    |
| 802.11a_Nss1,(6Mbps)_2TX       | 7.62            | 12.63                |
| 802.11ac VHT20_Nss1,(MCS0)_2TX | 7.42            | 12.43                |
| 802.11ac VHT40_Nss1,(MCS0)_2TX | 4.37            | 9.38                 |
| 802.11ac VHT80_Nss1,(MCS0)_2TX | 1.51            | 6.52                 |

RBW = 500kHz for 5.725-5.85GHz band / 1MHz for other band;





Result

| Mode                                    | Result | DG<br>(dBi) | Port 1<br>(dBm/RBW) | Port 2<br>(dBm/RBW) | PD<br>(dBm/RBW) | PD Limit<br>(dBm/RBW) | EIRP PD<br>(dBm/RBW) | EIRP PD Limit<br>(dBm/RBW) |
|---|--------|-------------|---------------------|---------------------|-----------------|-----------------------|----------------------|----------------------------|
| 802.11a_Nss1,(6Mbps)_2TX                | -      | -           | -                   | -                   | -               | -                     | -                    | -                          |
| 5180MHz_TnomVnom                        | Pass   | 5.01        | 7.54                | 7.12                | 10.14           | 11.00                 | 15.15                | 17.00                      |
| 5200MHz_TnomVnom                        | Pass   | 5.01        | 7.68                | 7.24                | 10.36           | 11.00                 | 15.37                | 17.00                      |
| 5240MHz_TnomVnom                        | Pass   | 5.01        | 7.05                | 6.96                | 9.80            | 11.00                 | 14.81                | 17.00                      |
| 5260MHz_TnomVnom                        | Pass   | 5.01        | 7.17                | 6.57                | 9.70            | 11.00                 | 14.71                | 17.00                      |
| 5300MHz_TnomVnom                        | Pass   | 5.01        | 7.10                | 6.83                | 9.78            | 11.00                 | 14.79                | 17.00                      |
| 5320MHz_TnomVnom                        | Pass   | 5.01        | 2.06                | 2.33                | 4.96            | 11.00                 | 9.97                 | 17.00                      |
| 5500MHz_TnomVnom                        | Pass   | 5.01        | 1.73                | 2.30                | 4.81            | 11.00                 | 9.82                 | 17.00                      |
| 5580MHz_TnomVnom                        | Pass   | 5.01        | 6.28                | 6.82                | 9.29            | 11.00                 | 14.30                | 17.00                      |
| 5700MHz_TnomVnom                        | Pass   | 5.01        | 2.38                | 3.52                | 5.63            | 11.00                 | 10.64                | 17.00                      |
| 5720MHz Straddle 5.47-5.725GHz_TnomVnom | Pass   | 5.01        | 5.75                | 6.33                | 8.77            | 11.00                 | 13.78                | 17.00                      |
| 5720MHz Straddle 5.725-5.85GHz_TnomVnom | Pass   | 5.01        | 4.16                | 5.02                | 7.62            | 30.00                 | 12.63                | 36.00                      |
| 5745MHz_TnomVnom                        | Pass   | 5.01        | 4.76                | 4.60                | 7.61            | 30.00                 | 12.62                | 36.00                      |
| 5785MHz_TnomVnom                        | Pass   | 5.01        | 3.77                | 4.46                | 7.09            | 30.00                 | 12.10                | 36.00                      |
| 5825MHz_TnomVnom                        | Pass   | 5.01        | 3.26                | 4.00                | 6.57            | 30.00                 | 11.58                | 36.00                      |
| 802.11ac VHT20_Nss1,(MCS0)_2TX          | -      | -           | -                   | -                   | -               | -                     | -                    | -                          |
| 5180MHz_TnomVnom                        | Pass   | 5.01        | 4.01                | 3.61                | 6.78            | 11.00                 | 11.79                | 17.00                      |
| 5200MHz_TnomVnom                        | Pass   | 5.01        | 7.26                | 6.84                | 10.00           | 11.00                 | 15.01                | 17.00                      |
| 5240MHz_TnomVnom                        | Pass   | 5.01        | 6.66                | 6.39                | 9.50            | 11.00                 | 14.51                | 17.00                      |
| 5260MHz_TnomVnom                        | Pass   | 5.01        | 6.61                | 6.09                | 9.14            | 11.00                 | 14.15                | 17.00                      |
| 5300MHz_TnomVnom                        | Pass   | 5.01        | 6.38                | 6.06                | 8.95            | 11.00                 | 13.96                | 17.00                      |
| 5320MHz_TnomVnom                        | Pass   | 5.01        | 6.14                | 6.00                | 9.08            | 11.00                 | 14.09                | 17.00                      |
| 5500MHz_TnomVnom                        | Pass   | 5.01        | 0.95                | 1.59                | 4.04            | 11.00                 | 9.05                 | 17.00                      |
| 5580MHz_TnomVnom                        | Pass   | 5.01        | 6.16                | 6.74                | 9.28            | 11.00                 | 14.29                | 17.00                      |
| 5700MHz_TnomVnom                        | Pass   | 5.01        | -1.12               | -0.37               | 2.10            | 11.00                 | 7.11                 | 17.00                      |
| 5720MHz Straddle 5.47-5.725GHz_TnomVnom | Pass   | 5.01        | 5.47                | 6.23                | 8.58            | 11.00                 | 13.59                | 17.00                      |
| 5720MHz Straddle 5.725-5.85GHz_TnomVnom | Pass   | 5.01        | 3.78                | 4.41                | 6.90            | 30.00                 | 11.91                | 36.00                      |
| 5745MHz_TnomVnom                        | Pass   | 5.01        | 4.33                | 4.75                | 7.42            | 30.00                 | 12.43                | 36.00                      |
| 5785MHz_TnomVnom                        | Pass   | 5.01        | 3.72                | 4.69                | 7.09            | 30.00                 | 12.10                | 36.00                      |
| 5825MHz_TnomVnom                        | Pass   | 5.01        | 3.40                | 3.98                | 6.48            | 30.00                 | 11.49                | 36.00                      |
| 802.11ac VHT40_Nss1,(MCS0)_2TX          | -      | -           | -                   | -                   | -               | -                     | -                    | -                          |
| 5190MHz_TnomVnom                        | Pass   | 5.01        | -1.26               | -1.60               | 1.45            | 11.00                 | 6.46                 | 17.00                      |
| 5230MHz_TnomVnom                        | Pass   | 5.01        | 3.10                | 2.92                | 5.81            | 11.00                 | 10.82                | 17.00                      |
| 5270MHz_TnomVnom                        | Pass   | 5.01        | 3.45                | 3.17                | 6.13            | 11.00                 | 11.14                | 17.00                      |
| 5310MHz_TnomVnom                        | Pass   | 5.01        | -2.23               | -2.47               | 0.47            | 11.00                 | 5.48                 | 17.00                      |
| 5510MHz_TnomVnom                        | Pass   | 5.01        | -2.36               | -2.53               | 0.40            | 11.00                 | 5.41                 | 17.00                      |
| 5550MHz_TnomVnom                        | Pass   | 5.01        | 3.05                | 3.47                | 6.09            | 11.00                 | 11.10                | 17.00                      |
| 5670MHz_TnomVnom                        | Pass   | 5.01        | 1.04                | 1.32                | 3.86            | 11.00                 | 8.87                 | 17.00                      |
| 5710MHz Straddle 5.47-5.725GHz_TnomVnom | Pass   | 5.01        | 2.42                | 3.16                | 5.65            | 11.00                 | 10.66                | 17.00                      |
| 5710MHz Straddle 5.725-5.85GHz_TnomVnom | Pass   | 5.01        | 0.69                | 1.14                | 3.74            | 30.00                 | 8.75                 | 36.00                      |
| 5755MHz_TnomVnom                        | Pass   | 5.01        | 1.35                | 1.63                | 4.37            | 30.00                 | 9.38                 | 36.00                      |
| 5795MHz_TnomVnom                        | Pass   | 5.01        | 0.69                | 1.26                | 3.86            | 30.00                 | 8.87                 | 36.00                      |
| 802.11ac VHT80_Nss1,(MCS0)_2TX          | -      | -           | -                   | -                   | -               | -                     | -                    | -                          |
| 5210MHz_TnomVnom                        | Pass   | 5.01        | -3.10               | -3.88               | -0.57           | 11.00                 | 4.44                 | 17.00                      |



| Mode                                    | Result | DG<br>(dBi) | Port 1<br>(dBm/RBW) | Port 2<br>(dBm/RBW) | PD<br>(dBm/RBW) | PD Limit<br>(dBm/RBW) | EIRP PD<br>(dBm/RBW) | EIRP PD Limit<br>(dBm/RBW) |
|---|--------|-------------|---------------------|---------------------|-----------------|-----------------------|----------------------|----------------------------|
| 5290MHz_TnomVnom                        | Pass   | 5.01        | -3.49               | -3.76               | -0.68           | 11.00                 | 4.33                 | 17.00                      |
| 5530MHz_TnomVnom                        | Pass   | 5.01        | -4.62               | -4.67               | -1.71           | 11.00                 | 3.30                 | 17.00                      |
| 5610MHz_TnomVnom                        | Pass   | 5.01        | -2.08               | -1.72               | 0.97            | 11.00                 | 5.98                 | 17.00                      |
| 5690MHz Straddle 5.47-5.725GHz_TnomVnom | Pass   | 5.01        | 0.89                | 1.25                | 3.84            | 11.00                 | 8.85                 | 17.00                      |
| 5690MHz Straddle 5.725-5.85GHz_TnomVnom | Pass   | 5.01        | -1.66               | -0.90               | 1.50            | 30.00                 | 6.51                 | 36.00                      |
| 5775MHz_TnomVnom                        | Pass   | 5.01        | -1.31               | -0.94               | 1.51            | 30.00                 | 6.52                 | 36.00                      |

**DG** = Directional Gain; **RBW** = 500kHz for 5.725-5.85GHz band / 1MHz for other band;  
**PD** = trace bin-by-bin of each transmits port summing can be performed maximum power density; **Port X** = Port Xpower density;

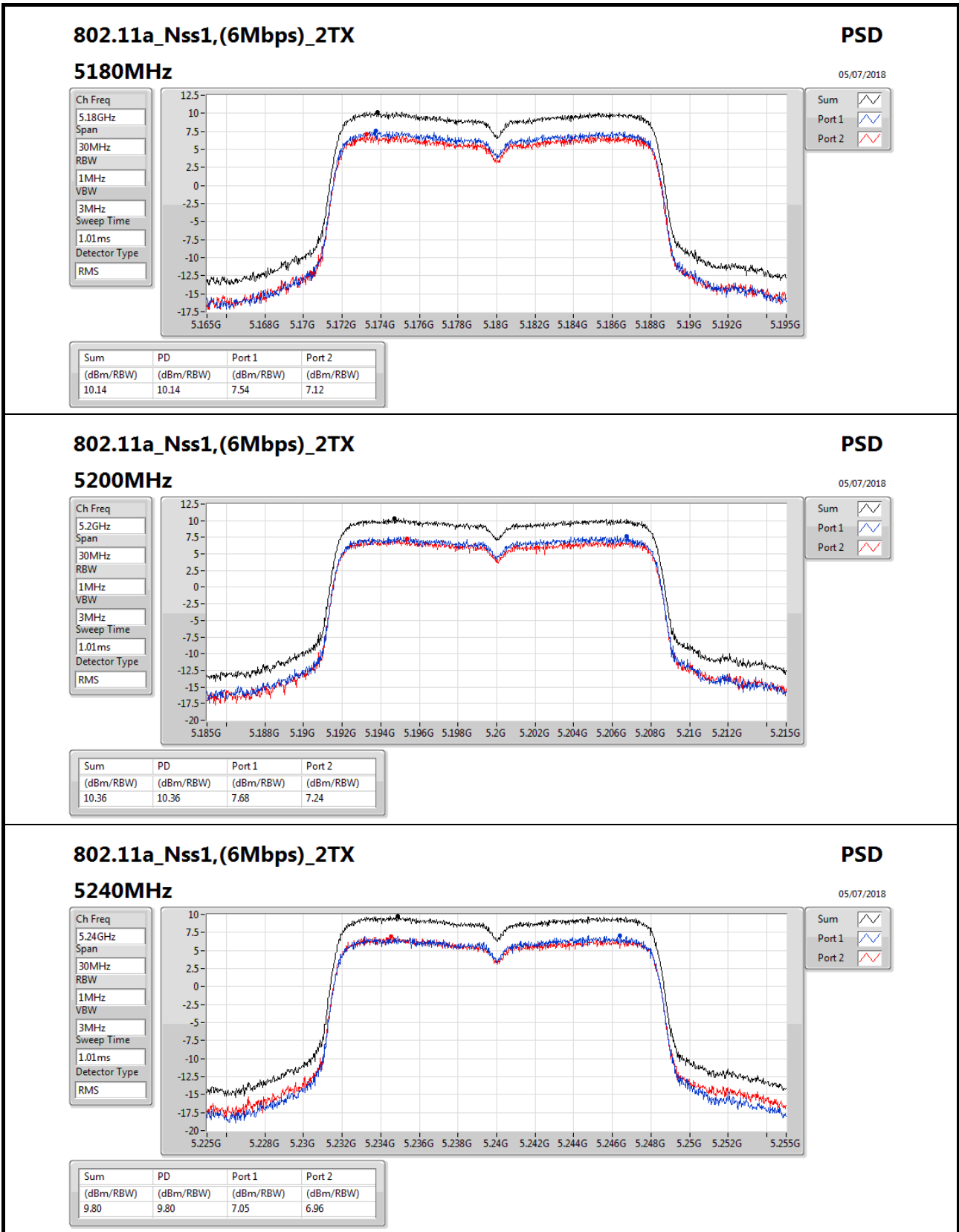

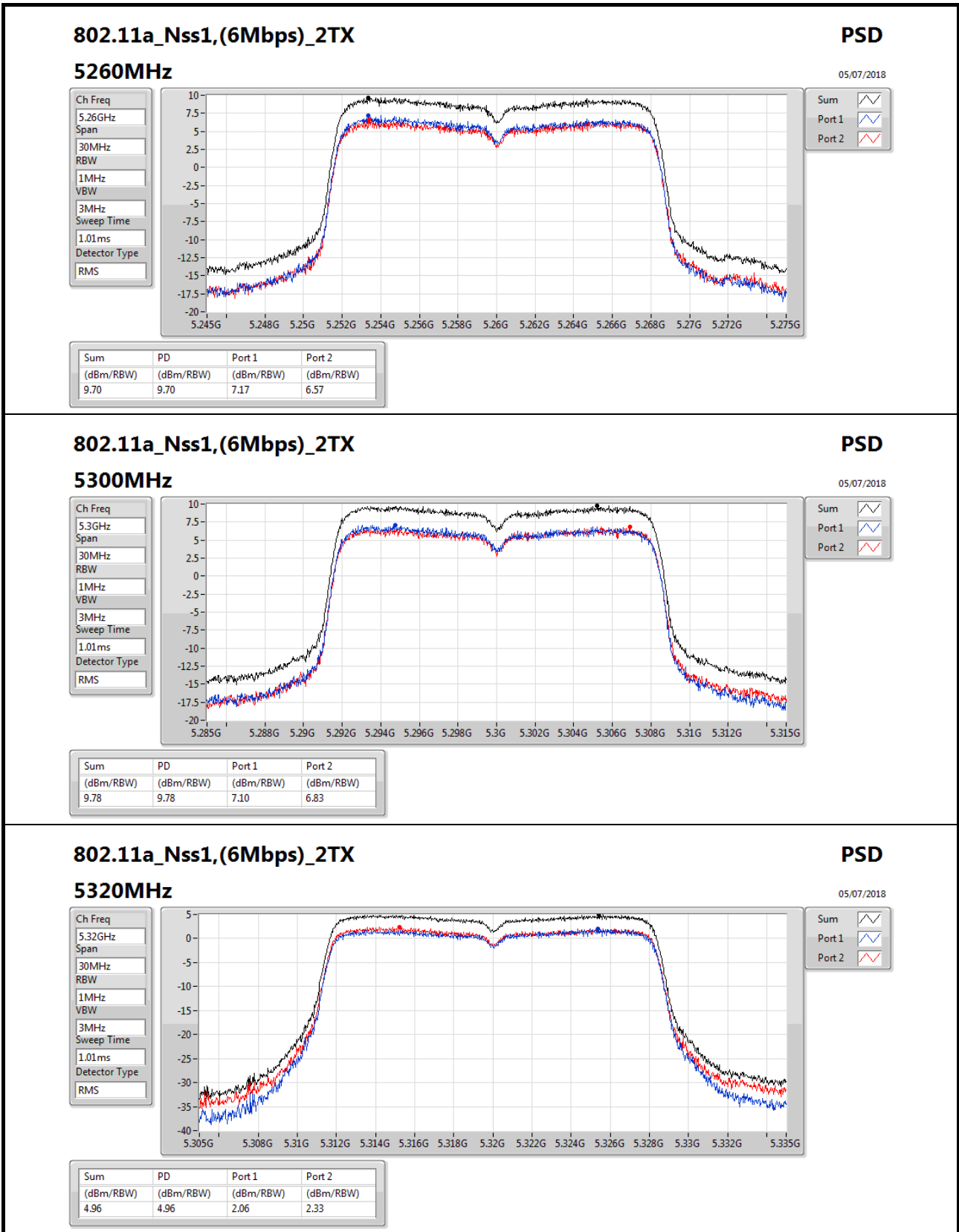

### 802.11a\_Nss1,(6Mbps)\_2TX

#### 5320MHz

**PSD**

05/07/2018

Ch Freq  
5.32GHz

Span  
30MHz

RBW  
1MHz

VBW  
3MHz

Sweep Time  
1.01ms

Detector Type  
RMS

Sum

Port 1

Port 2

| Sum       | PD        | Port 1    | Port 2    |
|-----------|-----------|-----------|-----------|
| (dBm/RBW) | (dBm/RBW) | (dBm/RBW) | (dBm/RBW) |
| 4.96      | 4.96      | 2.06      | 2.33      |

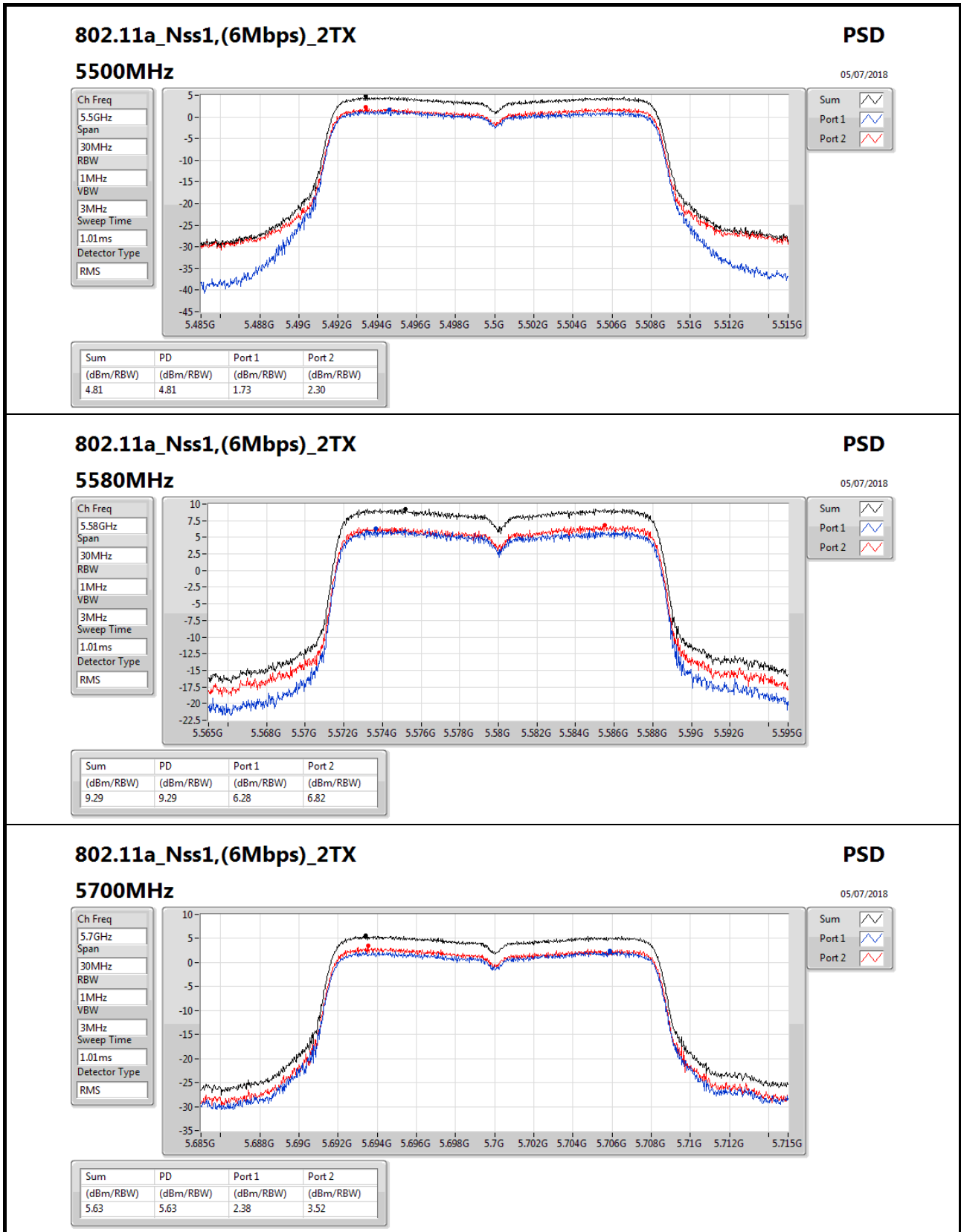

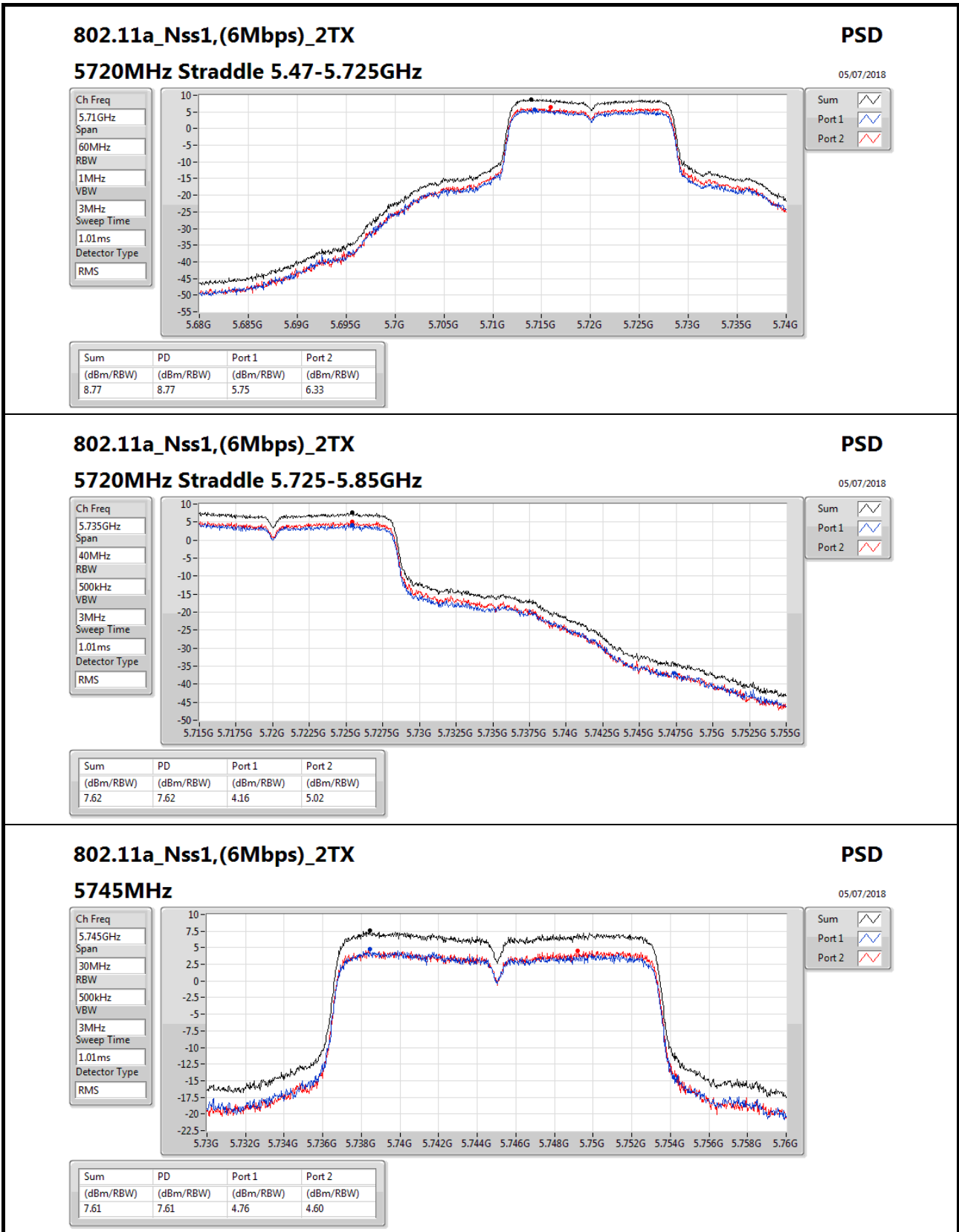

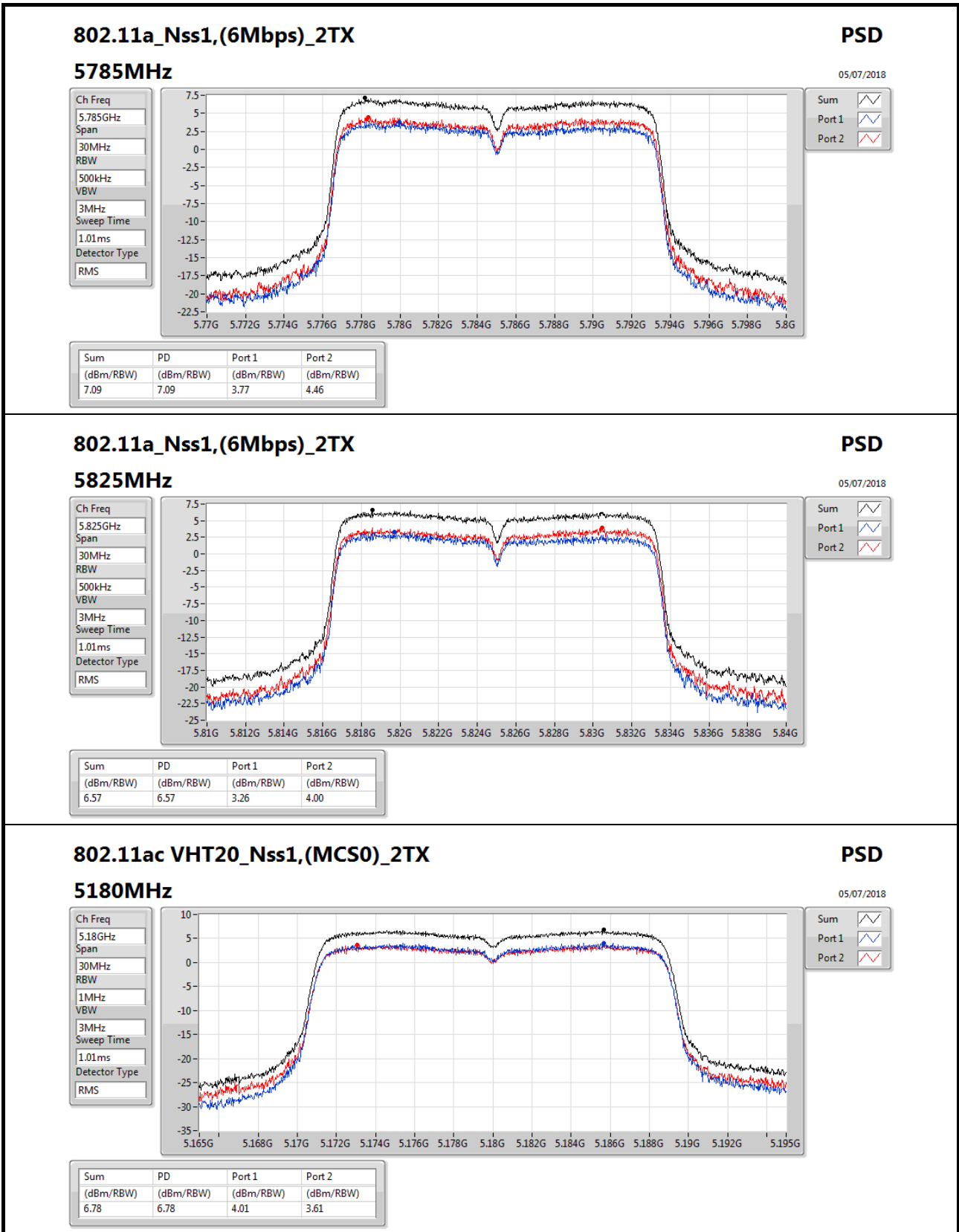

### 802.11ac VHT20\_Nss1,(MCS0)\_2TX

#### 5180MHz

**PSD**

05/07/2018

Ch Freq  
5.18GHz

Span  
30MHz

RBW  
1MHz

VBW  
3MHz

Sweep Time  
1.01ms

Detector Type  
RMS

Sum

Port 1

Port 2

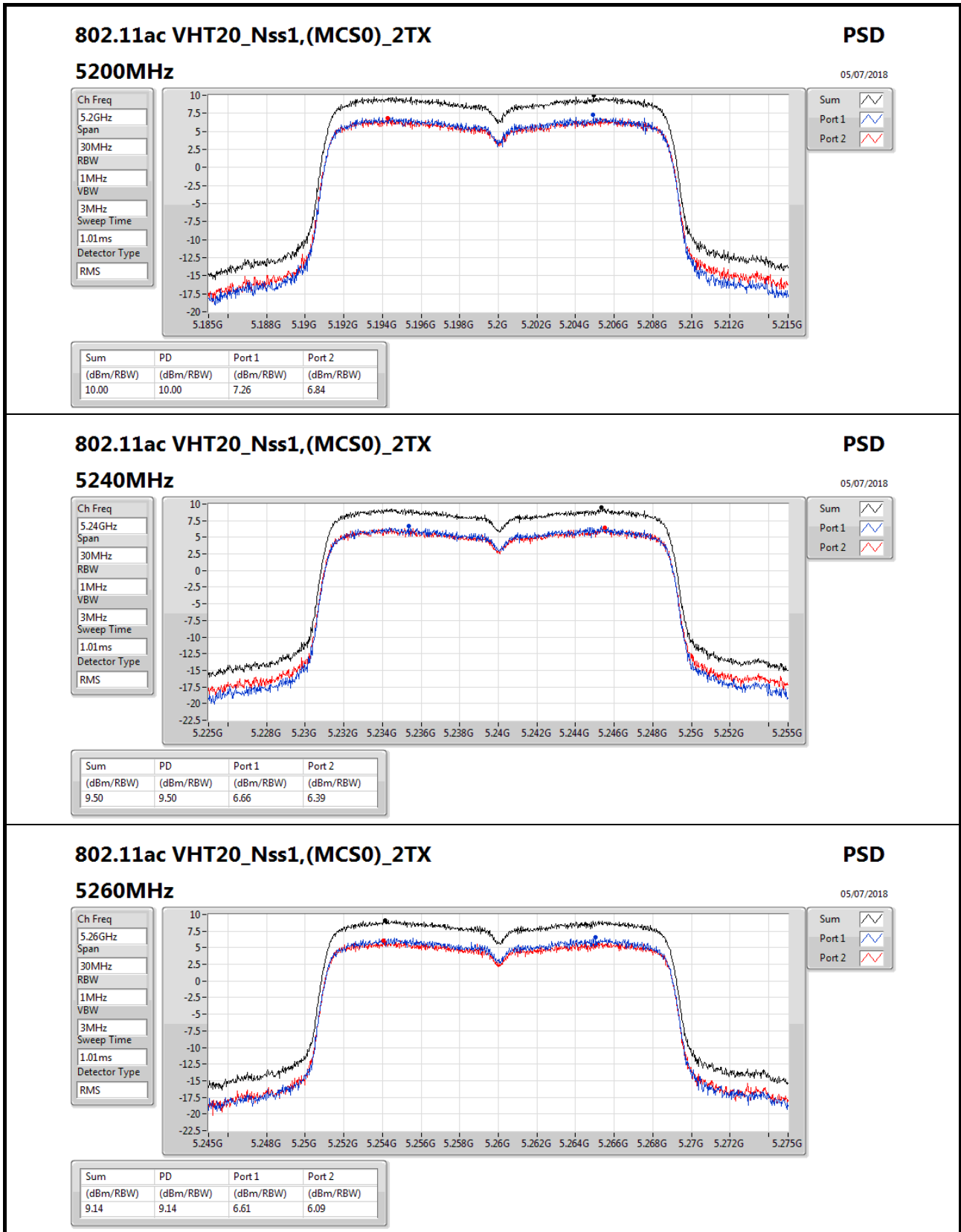



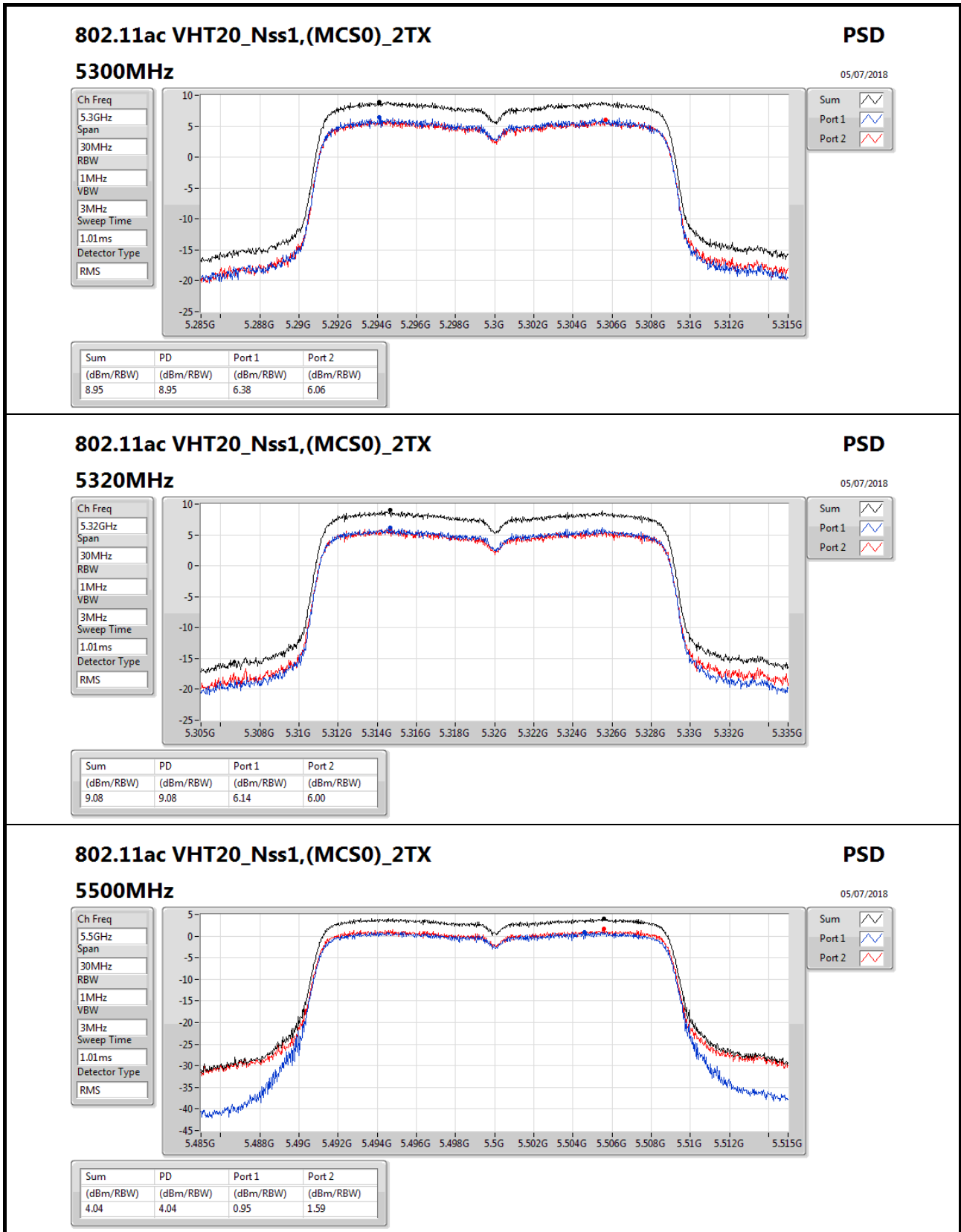

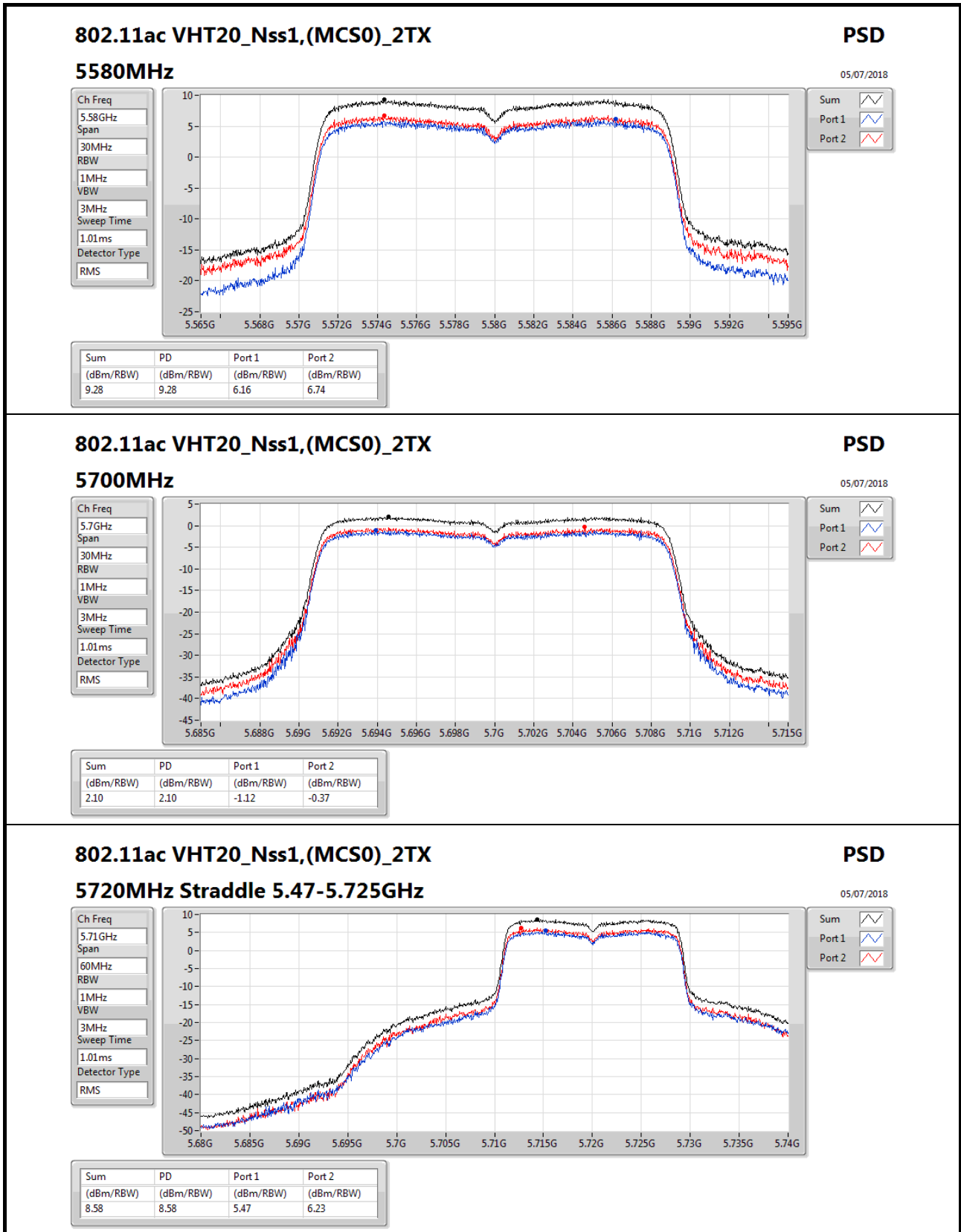

### 802.11ac VHT20\_Nss1,(MCS0)\_2TX

#### 5720MHz Straddle 5.47-5.725GHz

### PSD

05/07/2018

Ch Freq  
5.71GHz

Span  
60MHz

RBW  
1MHz

VBW  
3MHz

Sweep Time  
1.01ms

Detector Type  
RMS

Sum

Port 1

Port 2

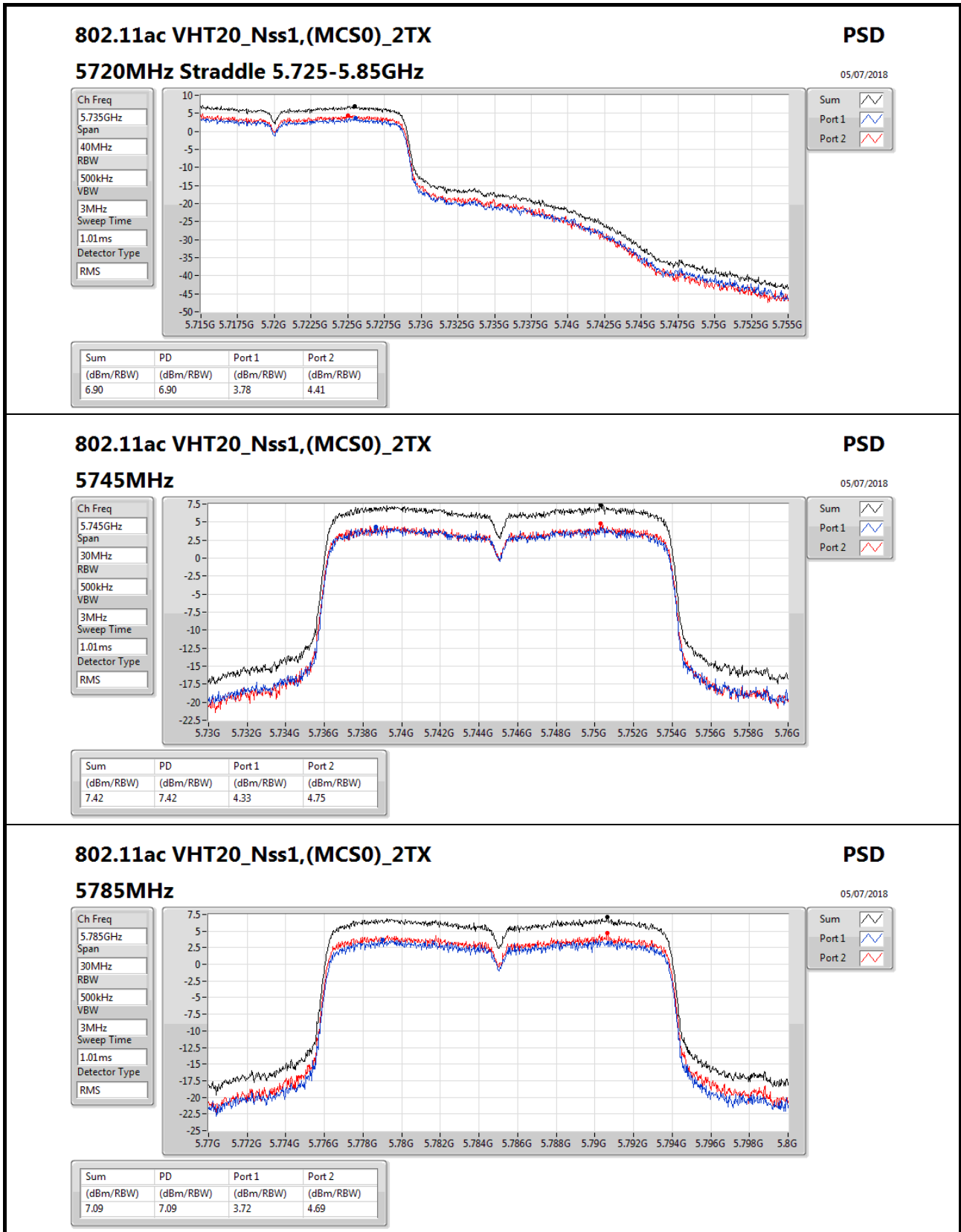

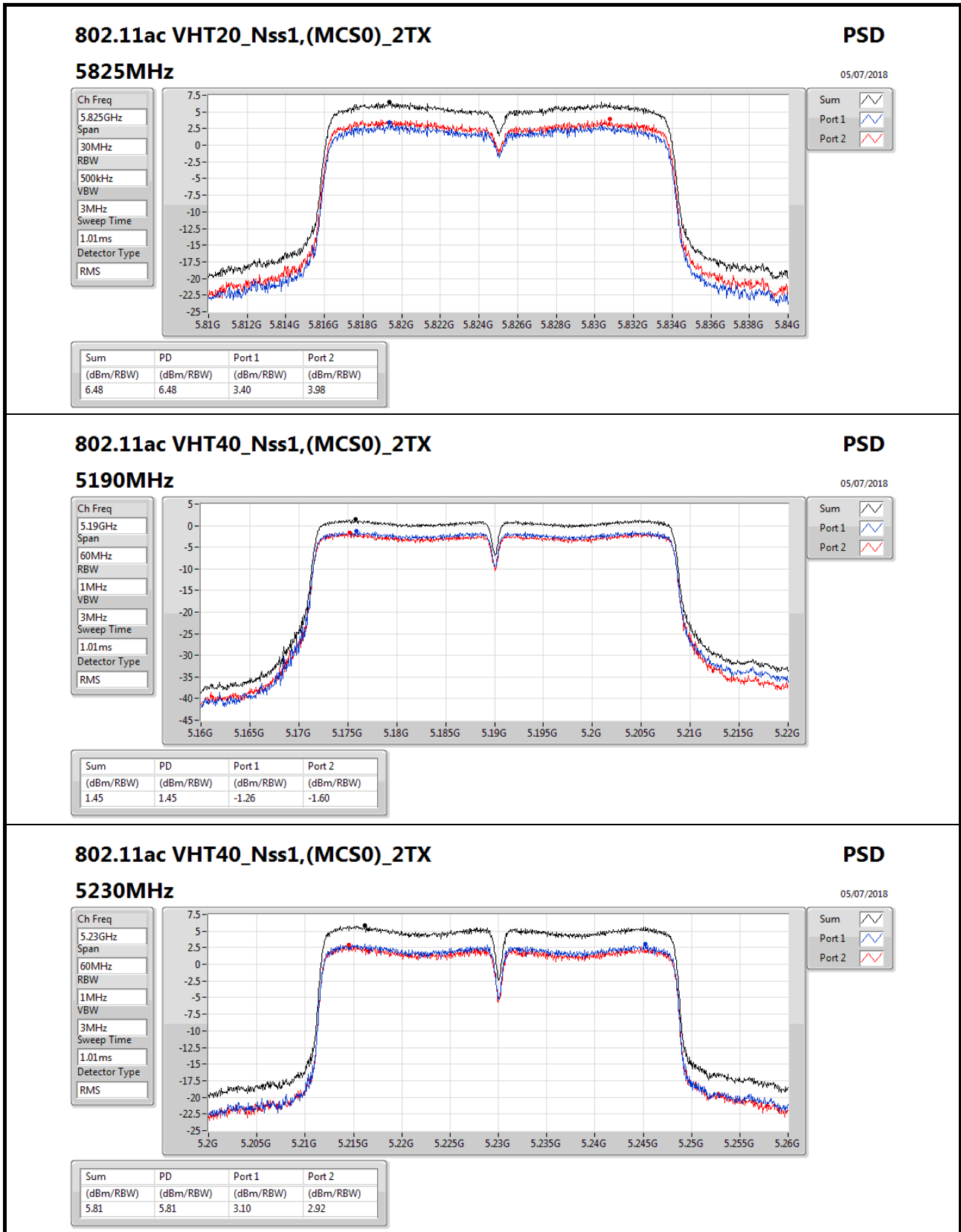

### 802.11ac VHT40\_Nss1,(MCS0)\_2TX

#### 5230MHz

**PSD**

05/07/2018

Ch Freq  
5.23GHz

Span  
60MHz

RBW  
1MHz

VBW  
3MHz

Sweep Time  
1.01ms

Detector Type  
RMS

Sum

Port 1

Port 2

| Sum       | PD        | Port 1    | Port 2    |
|-----------|-----------|-----------|-----------|
| (dBm/RBW) | (dBm/RBW) | (dBm/RBW) | (dBm/RBW) |
| 5.81      | 5.81      | 3.10      | 2.92      |

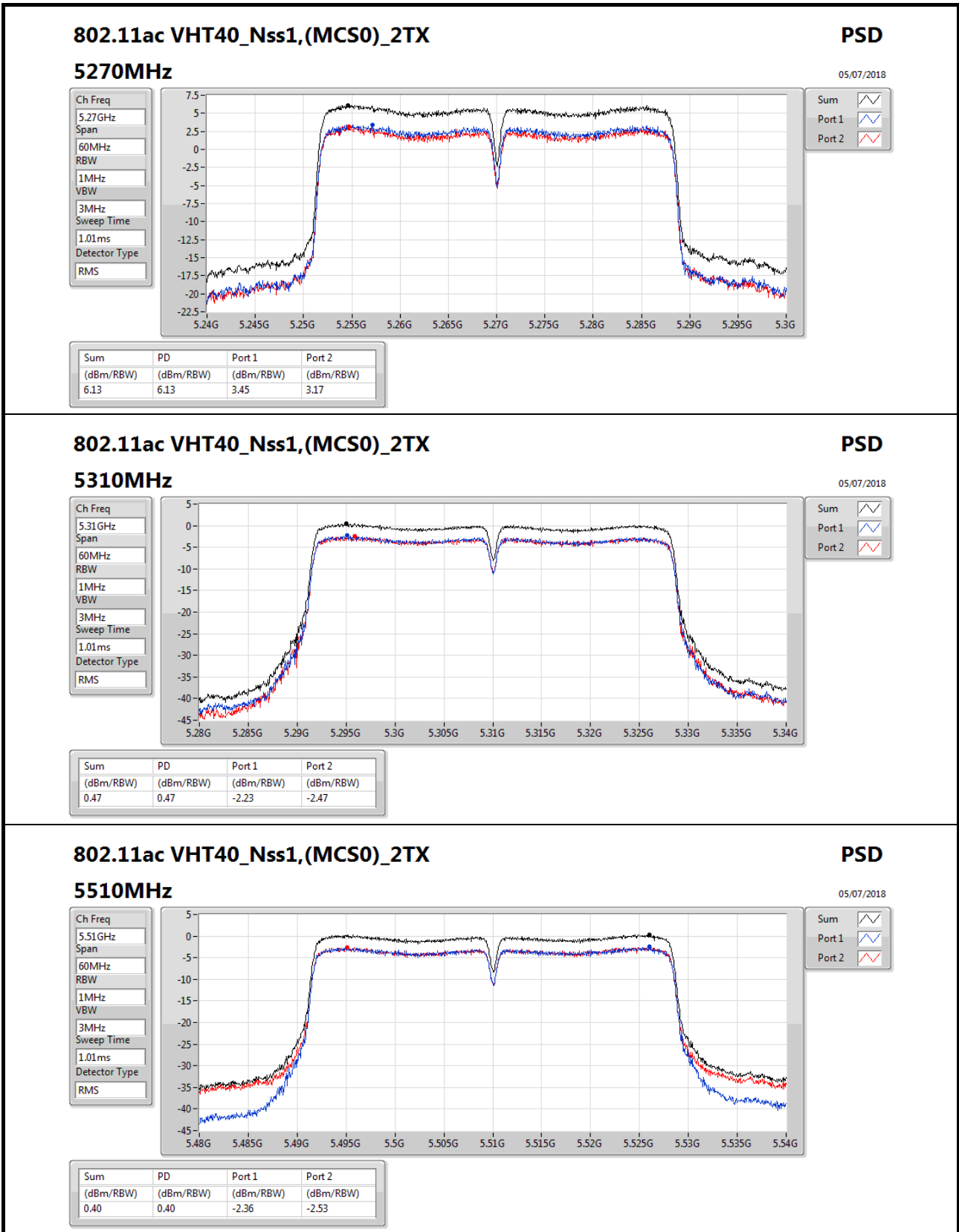

### 802.11ac VHT40\_Nss1,(MCS0)\_2TX

#### 5510MHz

**PSD**

05/07/2018

Ch Freq  
5.51GHz

Span  
60MHz

RBW  
1MHz

VBW  
3MHz

Sweep Time  
1.01ms

Detector Type  
RMS

Sum

Port 1

Port 2

| Sum       | PD        | Port 1    | Port 2    |
|-----------|-----------|-----------|-----------|
| (dBm/RBW) | (dBm/RBW) | (dBm/RBW) | (dBm/RBW) |
| 0.40      | 0.40      | -2.36     | -2.53     |

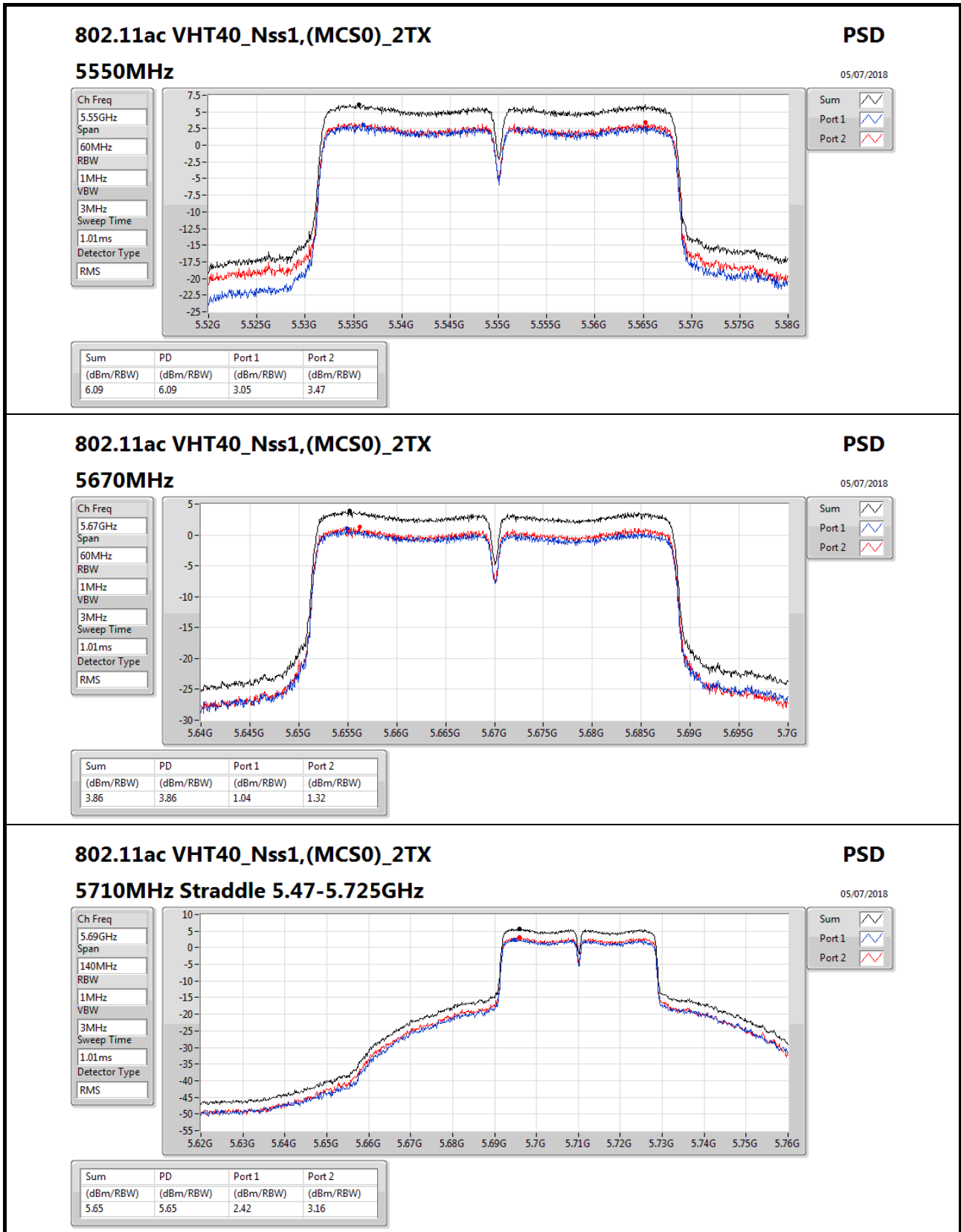

### 802.11ac VHT40\_Nss1,(MCS0)\_2TX

#### 5710MHz Straddle 5.47-5.725GHz

**PSD**

05/07/2018

Ch Freq  
5.69GHz

Span  
140MHz

RBW  
1MHz

VBW  
3MHz

Sweep Time  
1.01ms

Detector Type  
RMS

Sum

Port 1

Port 2

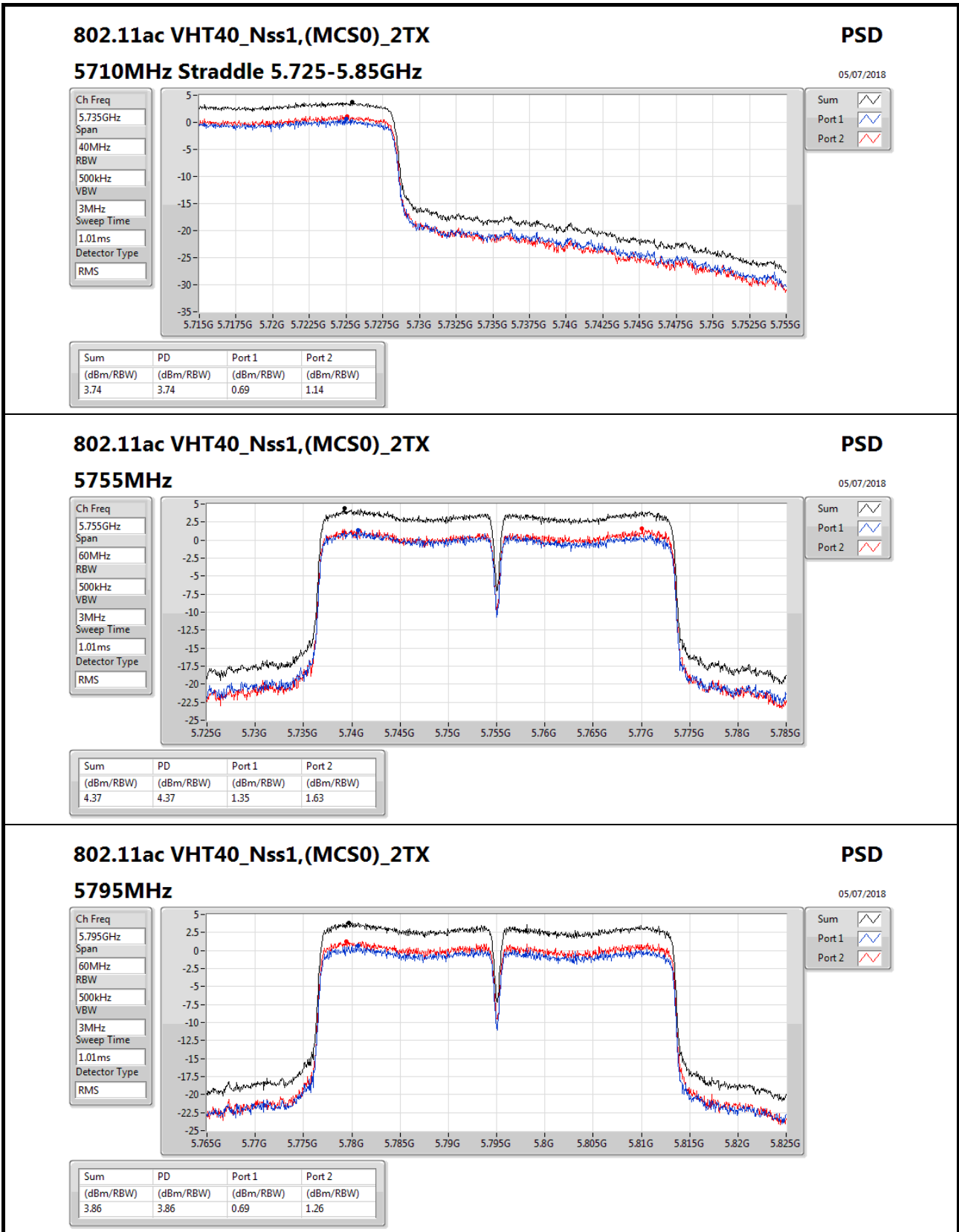

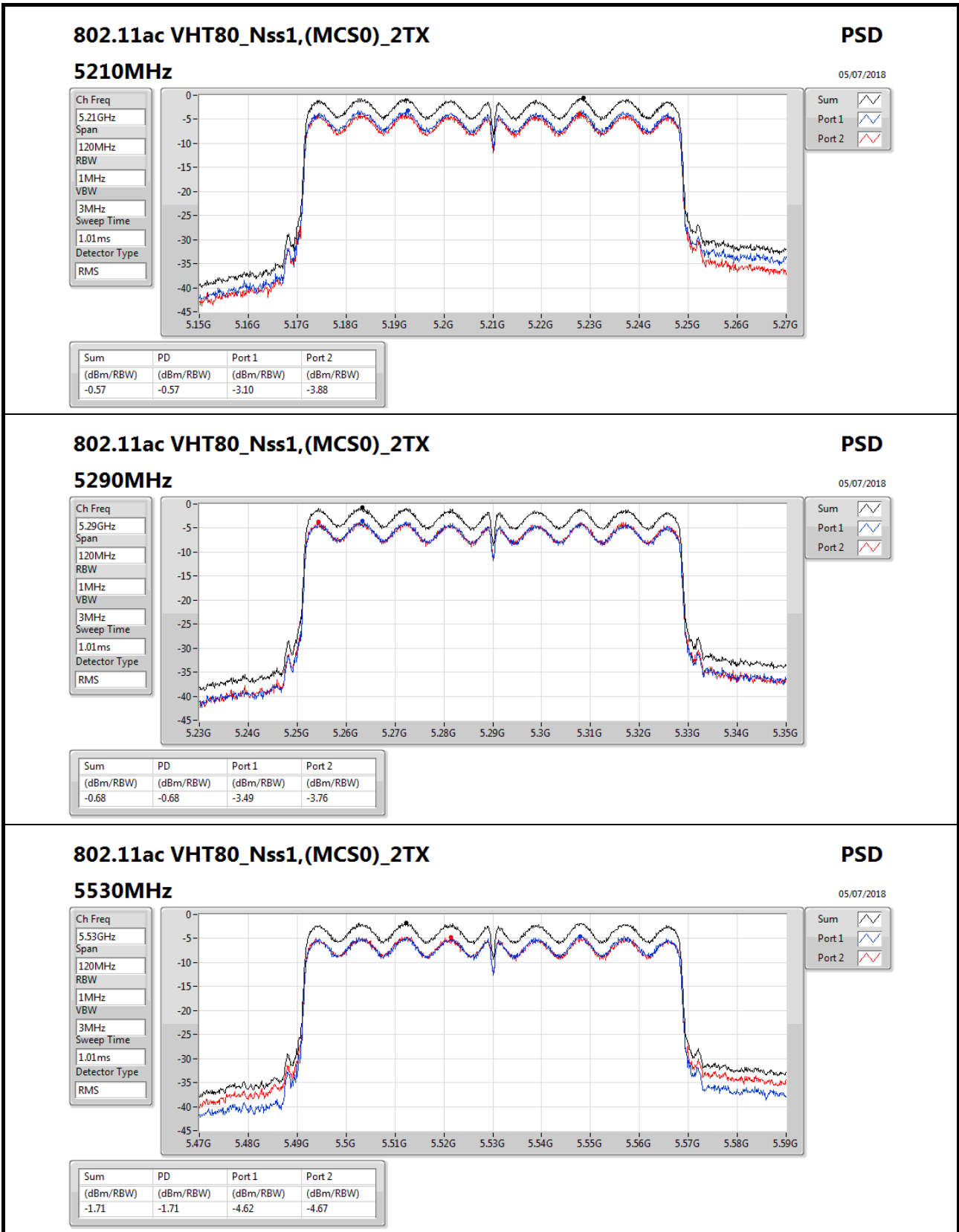

### 802.11ac VHT80\_Nss1,(MCS0)\_2TX

#### 5530MHz

**PSD**

05/07/2018

Ch Freq  
5.53GHz

Span  
120MHz

RBW  
1MHz

VBW  
3MHz

Sweep Time  
1.01ms

Detector Type  
RMS

Sum

Port 1

Port 2

| Sum       | PD        | Port 1    | Port 2    |
|-----------|-----------|-----------|-----------|
| (dBm/RBW) | (dBm/RBW) | (dBm/RBW) | (dBm/RBW) |
| -1.71     | -1.71     | -4.62     | -4.67     |



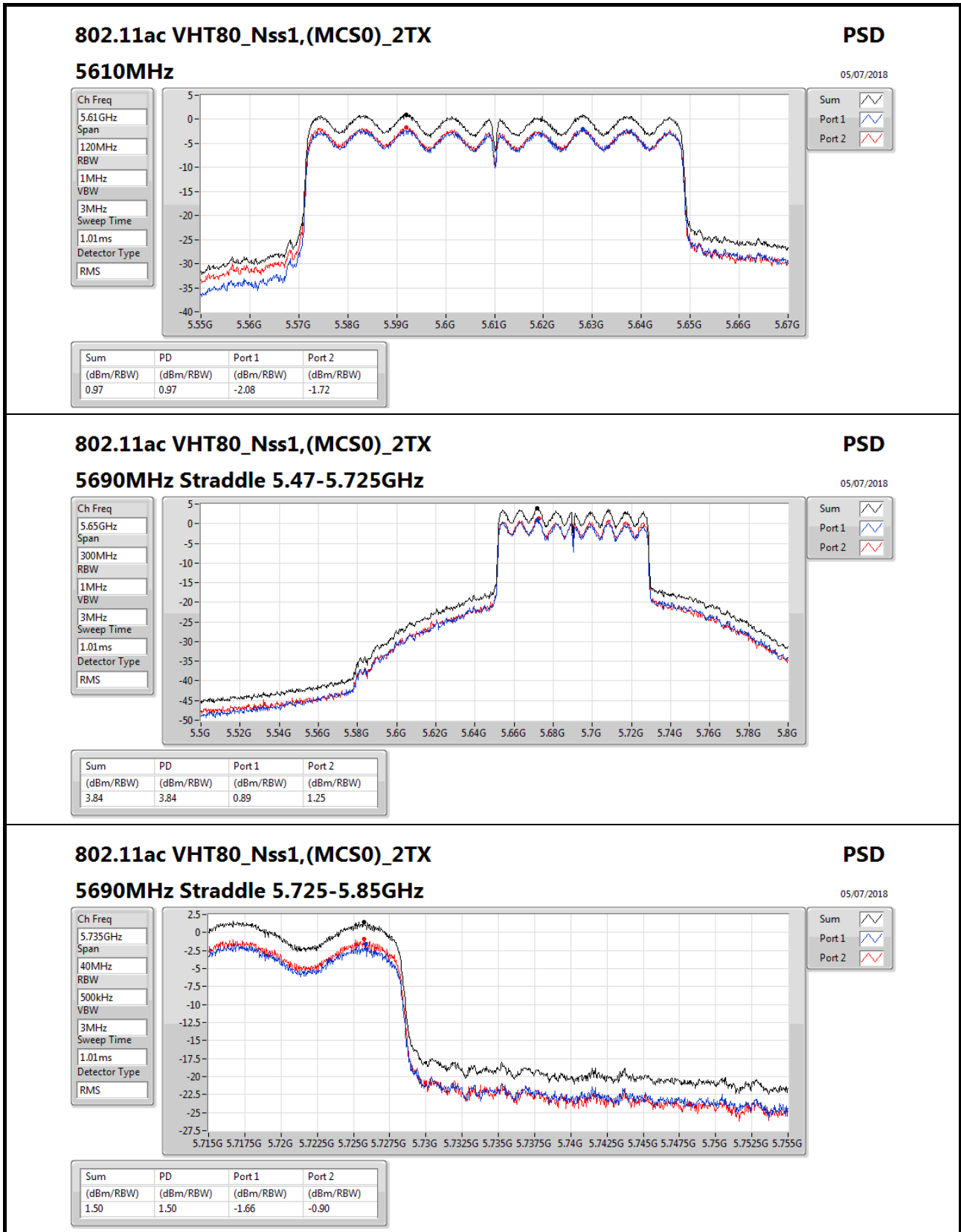

### 802.11ac VHT80\_Nss1,(MCS0)\_2TX

#### 5690MHz Straddle 5.725-5.85GHz

### PSD

05/07/2018

Ch Freq  
5.735GHz

Span  
40MHz

RBW  
500kHz

VBW  
3MHz

Sweep Time  
1.01ms

Detector Type  
RMS

Sum

Port 1

Port 2



### 802.11ac VHT80\_Nss1,(MCS0)\_2TX

### PSD

5775MHz

05/07/2018

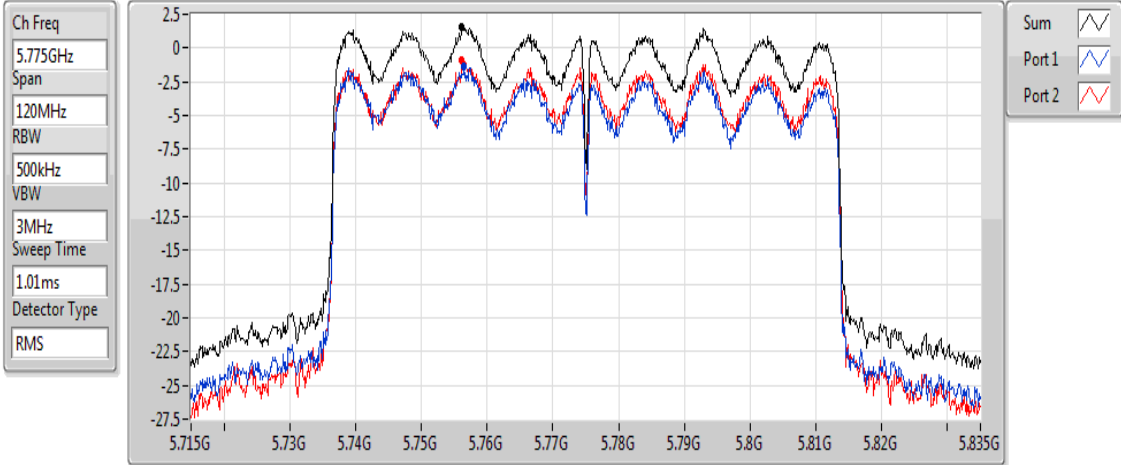

| Sum       | PD        | Port 1    | Port 2    |
|-----------|-----------|-----------|-----------|
| (dBm/RBW) | (dBm/RBW) | (dBm/RBW) | (dBm/RBW) |
| 1.51      | 1.51      | -1.31     | -0.94     |



Summary

| Mode                           | Result | Type | Freq (Hz) | Level (dBuV/m) | Limit (dBuV/m) | Margin (dB) | Factor (dB) | Dist (m) | Condition  | Azimuth (°) | Height (m) | Comments |
|--------------------------------|--------|------|-----------|----------------|----------------|-------------|-------------|----------|------------|-------------|------------|----------|
| 5.725-5.85GHz                  | -      | -    | -         | -              | -              | -           | -           | -        | -          | -           | -          | -        |
| 802.11ac VHT80_Nss1,(MCS0)_2TX | Pass   | PK   | 198.78M   | 34.88          | 43.50          | -8.62       | -21.08      | 3        | Horizontal | 0           | 1.00       | -        |



**Result**

| Mode                           | Result | Type | Freq (Hz) | Level (dBuV/m) | Limit (dBuV/m) | Margin (dB) | Factor (dB) | Dist (m) | Condition  | Azimuth (°) | Height (m) | Comments |
|--------------------------------|--------|------|-----------|----------------|----------------|-------------|-------------|----------|------------|-------------|------------|----------|
| 802.11ac VHT80_Nss1,(MCS0)_2TX | -      | -    | -         | -              | -              | -           | -           | -        | -          | -           | -          | -        |
| 5775MHz                        | Pass   | PK   | 33.88M    | 26.31          | 40.00          | -13.69      | -15.32      | 3        | Vertical   | 360         | 1.00       | -        |
| 5775MHz                        | Pass   | PK   | 123.12M   | 27.09          | 43.50          | -16.41      | -19.24      | 3        | Vertical   | 360         | 1.00       | -        |
| 5775MHz                        | Pass   | PK   | 196.84M   | 25.61          | 43.50          | -17.89      | -21.15      | 3        | Vertical   | 360         | 1.00       | -        |
| 5775MHz                        | Pass   | PK   | 567.38M   | 29.03          | 46.00          | -16.97      | -10.55      | 3        | Vertical   | 360         | 1.00       | -        |
| 5775MHz                        | Pass   | PK   | 610.06M   | 29.45          | 46.00          | -16.55      | -10.59      | 3        | Vertical   | 360         | 1.00       | -        |
| 5775MHz                        | Pass   | PK   | 856.44M   | 30.35          | 46.00          | -15.65      | -7.01       | 3        | Vertical   | 360         | 1.00       | -        |
| 5775MHz                        | Pass   | PK   | 99.84M    | 27.34          | 43.50          | -16.16      | -21.09      | 3        | Horizontal | 0           | 1.00       | -        |
| 5775MHz                        | Pass   | PK   | 198.78M   | 34.88          | 43.50          | -8.62       | -21.08      | 3        | Horizontal | 0           | 1.00       | -        |
| 5775MHz                        | Pass   | PK   | 293.84M   | 31.73          | 46.00          | -14.27      | -16.80      | 3        | Horizontal | 0           | 1.00       | -        |
| 5775MHz                        | Pass   | PK   | 507.24M   | 32.87          | 46.00          | -13.13      | -12.11      | 3        | Horizontal | 0           | 1.00       | -        |
| 5775MHz                        | Pass   | PK   | 631.4M    | 28.13          | 46.00          | -17.87      | -10.06      | 3        | Horizontal | 0           | 1.00       | -        |
| 5775MHz                        | Pass   | PK   | 720.64M   | 28.46          | 46.00          | -17.54      | -9.24       | 3        | Horizontal | 0           | 1.00       | -        |



### 802.11ac VHT80\_Nss1,(MCS0)\_2TX

### 5775MHz\_USB

05/07/2018

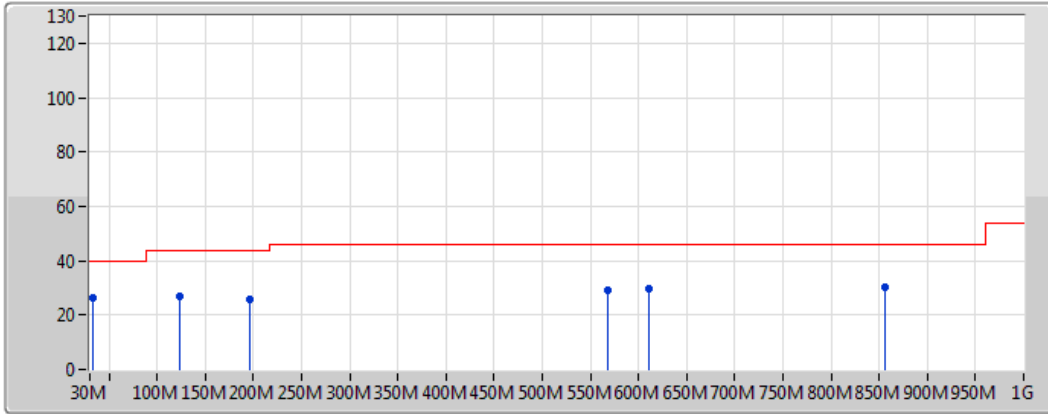

Legend for the spectrum plot:

- Lim.PK: Red line with a sawtooth pattern
- PK: Blue line with a sawtooth pattern
- Lim.AV: Red line with a sawtooth pattern
- AV: Black line with a sawtooth pattern

| Type | Freq (Hz) | Level (dBuV/m) | Limit (dBuV/m) | Margin (dB) | Factor (dB) | Dist (m) | Condition | Azimuth (°) | Height (m) | Comments |
|------|-----------|----------------|----------------|-------------|-------------|----------|-----------|-------------|------------|----------|
| PK   | 33.88M    | 26.31          | 40.00          | -13.69      | -15.32      | 3        | Vertical  | 360         | 1.00       | -        |
| PK   | 123.12M   | 27.09          | 43.50          | -16.41      | -19.24      | 3        | Vertical  | 360         | 1.00       | -        |
| PK   | 196.84M   | 25.61          | 43.50          | -17.89      | -21.15      | 3        | Vertical  | 360         | 1.00       | -        |
| PK   | 567.38M   | 29.03          | 46.00          | -16.97      | -10.55      | 3        | Vertical  | 360         | 1.00       | -        |
| PK   | 610.06M   | 29.45          | 46.00          | -16.55      | -10.59      | 3        | Vertical  | 360         | 1.00       | -        |
| PK   | 856.44M   | 30.35          | 46.00          | -15.65      | -7.01       | 3        | Vertical  | 360         | 1.00       | -        |

### 802.11ac VHT80\_Nss1,(MCS0)\_2TX

### 5775MHz\_USB

05/07/2018

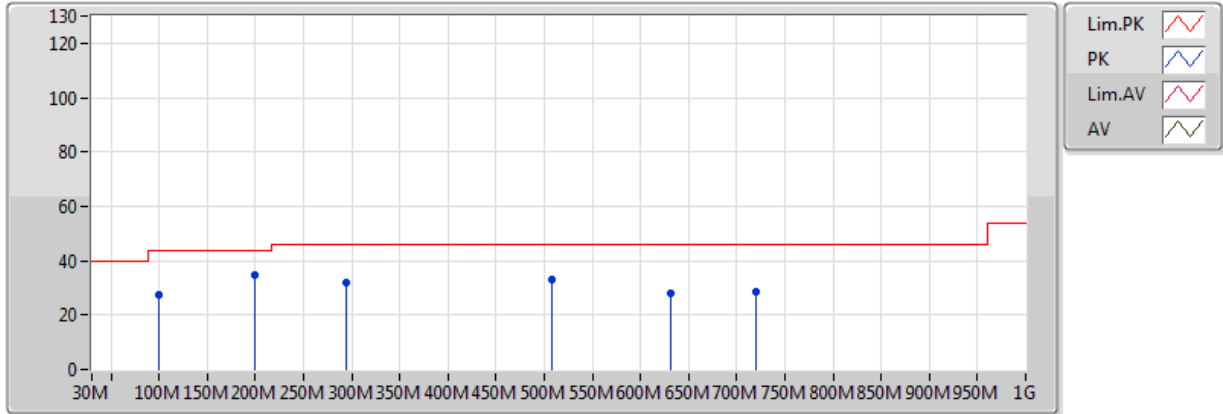

| Type | Freq (Hz) | Level (dBuV/m) | Limit (dBuV/m) | Margin (dB) | Factor (dB) | Dist (m) | Condition  | Azimuth (°) | Height (m) | Comments |
|------|-----------|----------------|----------------|-------------|-------------|----------|------------|-------------|------------|----------|
| PK   | 99.84M    | 27.34          | 43.50          | -16.16      | -21.09      | 3        | Horizontal | 0           | 1.00       | -        |
| PK   | 198.78M   | 34.88          | 43.50          | -8.62       | -21.08      | 3        | Horizontal | 0           | 1.00       | -        |
| PK   | 293.84M   | 31.73          | 46.00          | -14.27      | -16.80      | 3        | Horizontal | 0           | 1.00       | -        |
| PK   | 507.24M   | 32.87          | 46.00          | -13.13      | -12.11      | 3        | Horizontal | 0           | 1.00       | -        |
| PK   | 631.4M    | 28.13          | 46.00          | -17.87      | -10.06      | 3        | Horizontal | 0           | 1.00       | -        |
| PK   | 720.64M   | 28.46          | 46.00          | -17.54      | -9.24       | 3        | Horizontal | 0           | 1.00       | -        |