

UNII-2c IEEE 802.11n HT40 mode- chain 1

Low CH

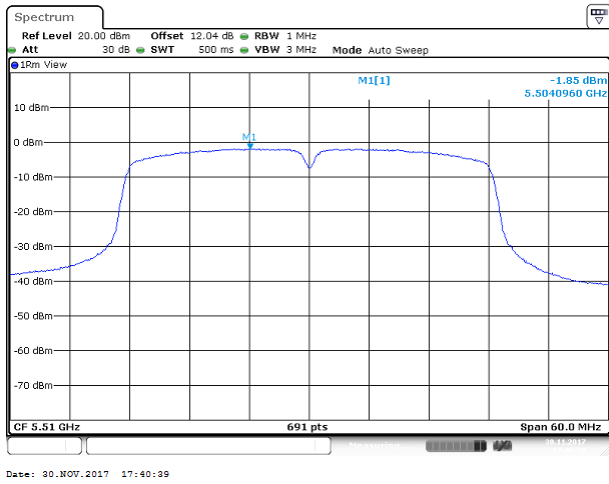

Mid CH

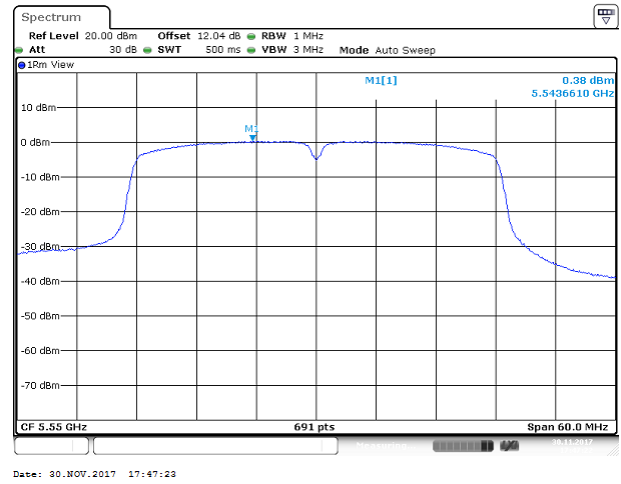

High CH

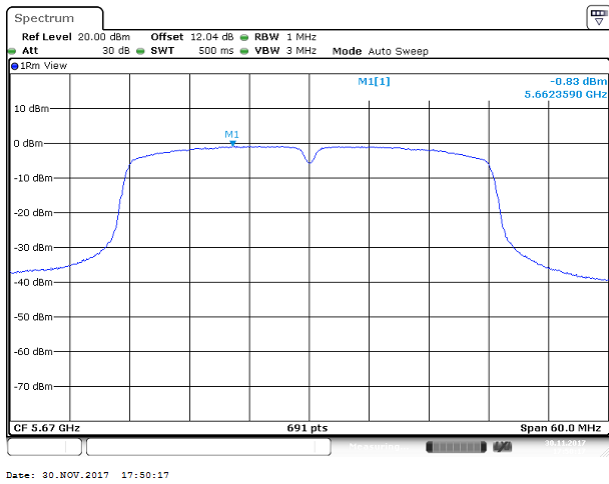

Cross CH

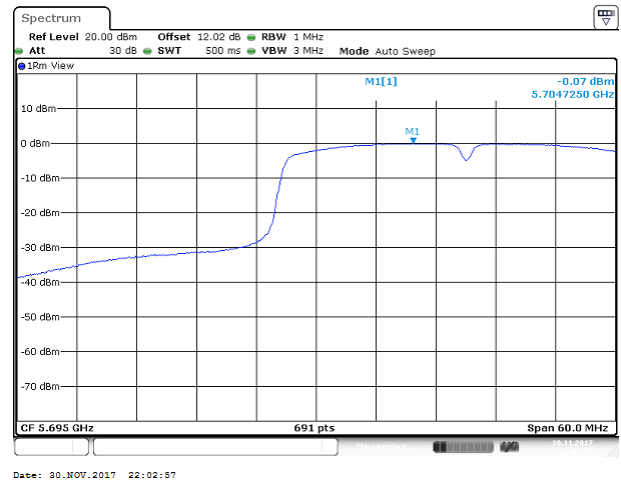

UNII-2c IEEE 802.11ac VHT80 mode- chain 0

Mid CH

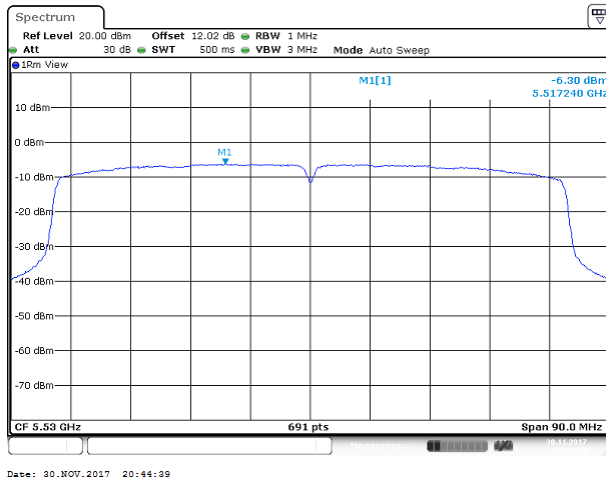

Cross CH

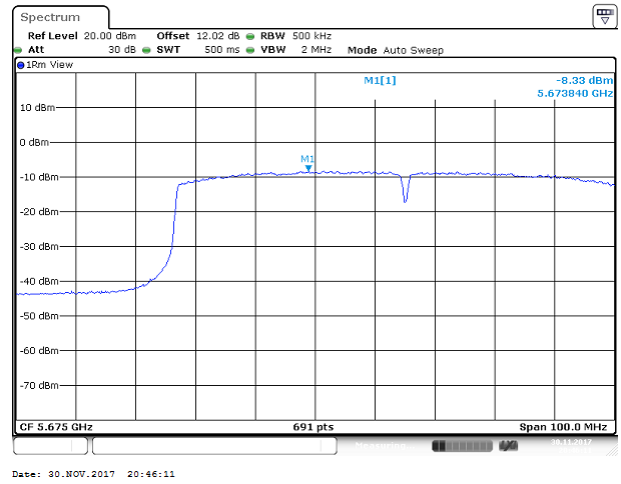

UNII-2c IEEE 802.11ac VHT80 mode- chain 1

Mid CH

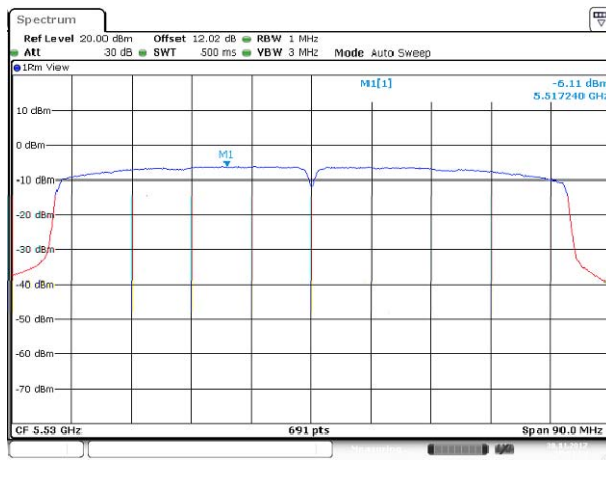

Cross CH

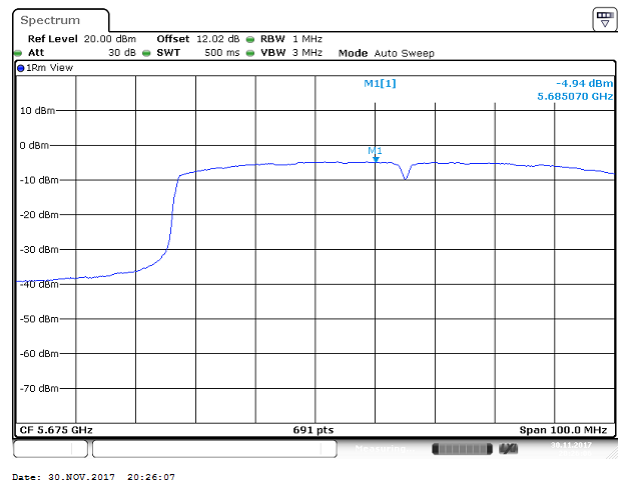

Test Data

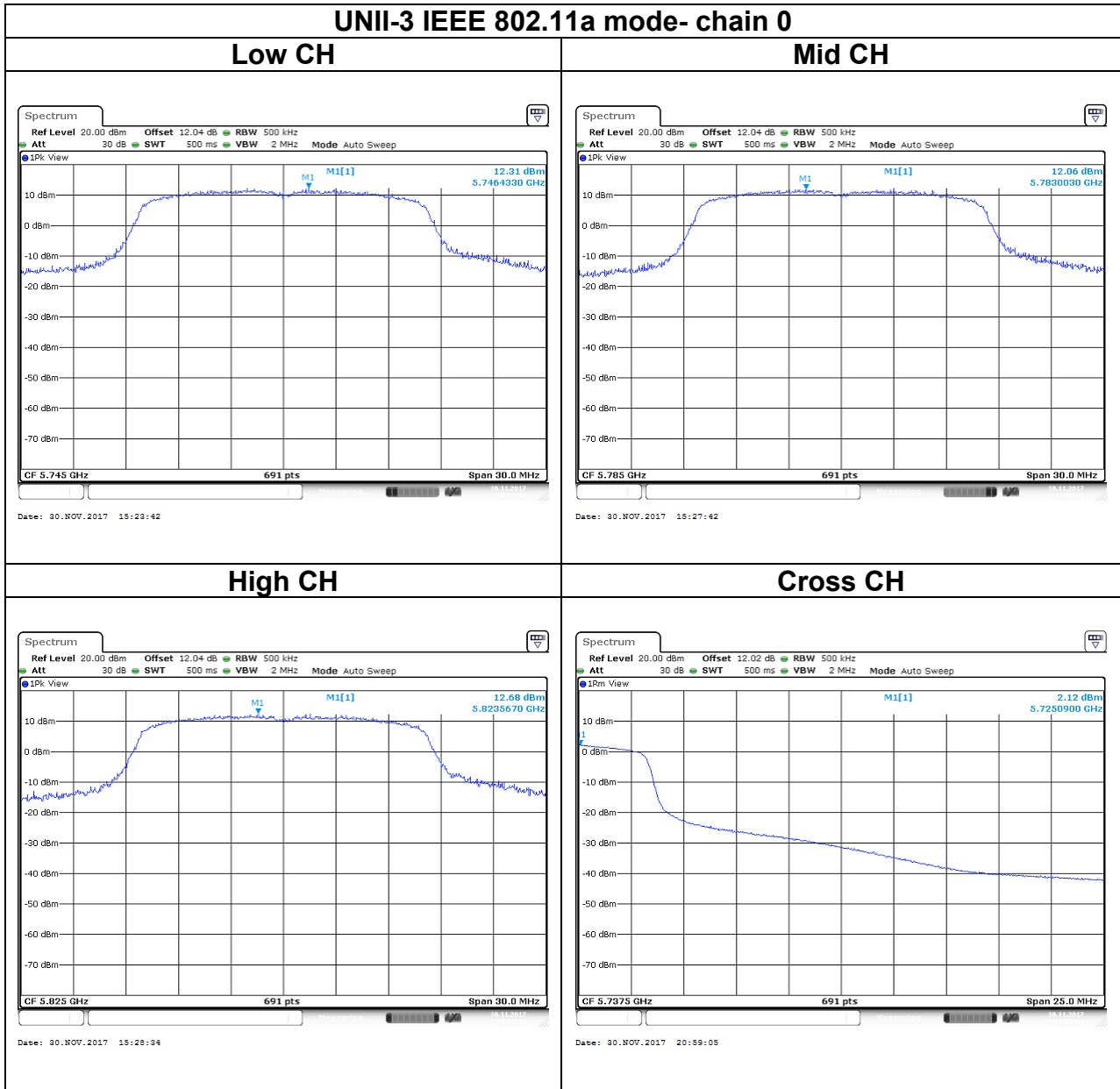

UNII-3 IEEE 802.11n HT20 mode- chain 0

Low CH

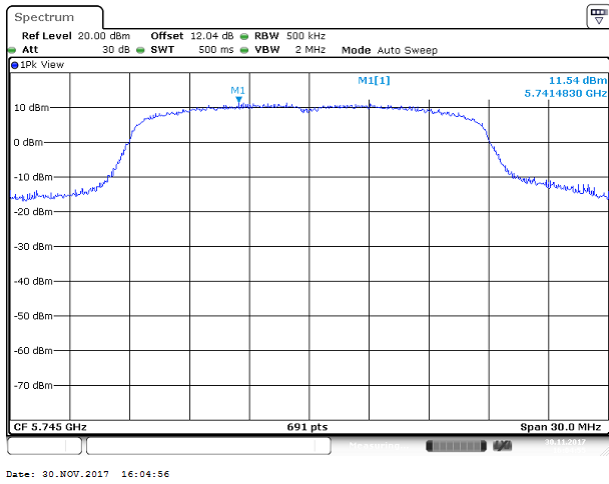

Mid CH

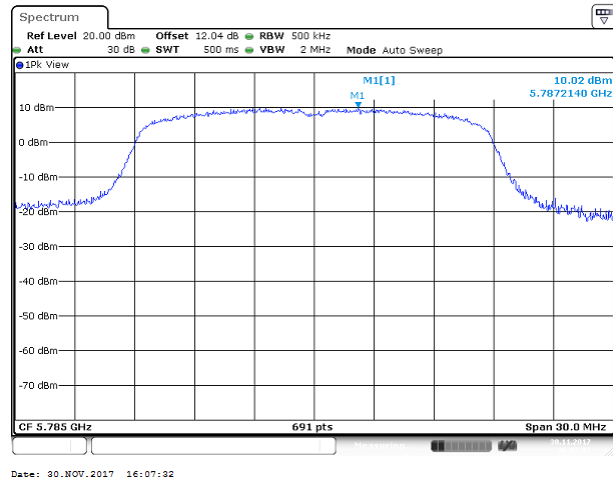

High CH

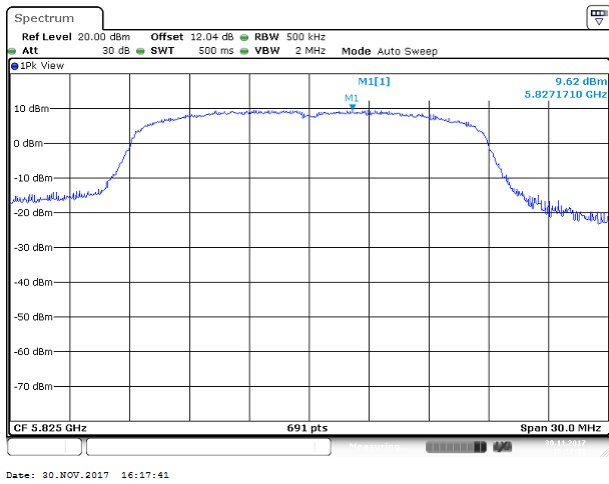

Cross CH

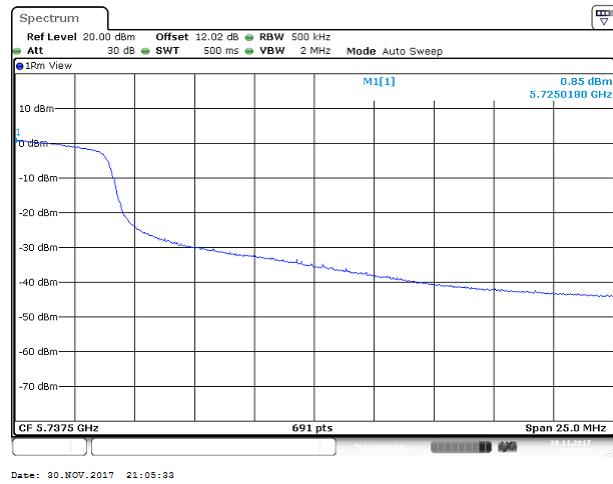

UNII-3 IEEE 802.11n HT20 mode- chain 1

Low CH

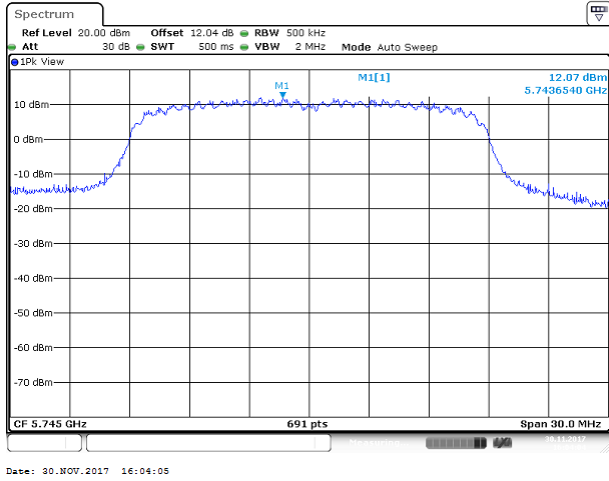

Mid CH

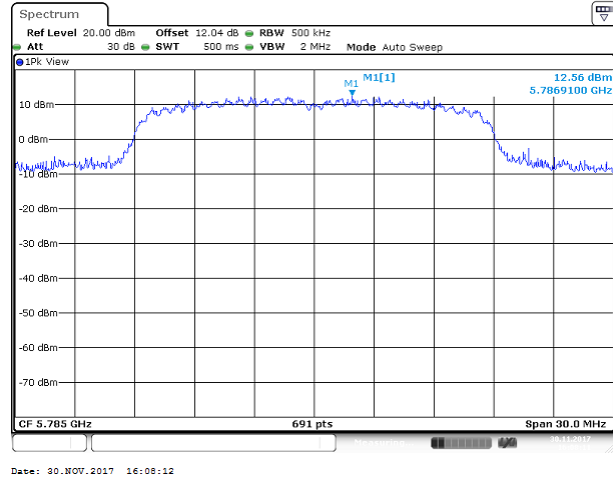

High CH

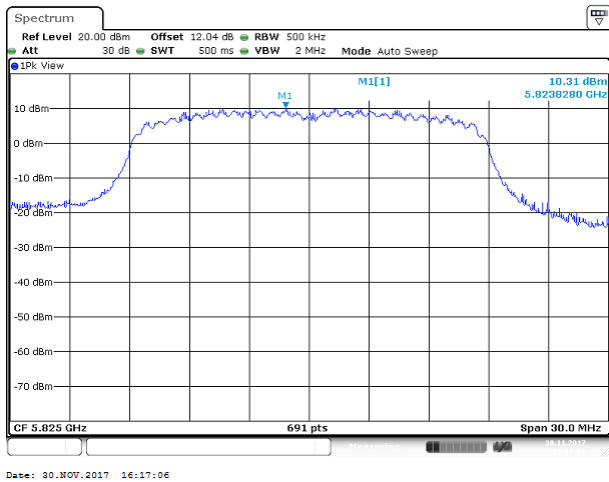

Cross CH

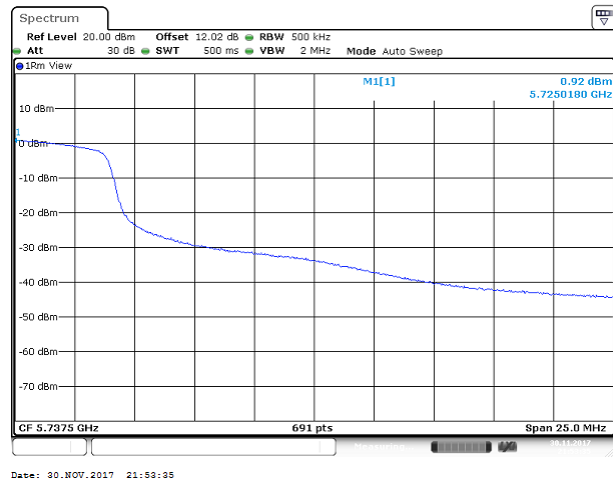

UNII-3 IEEE 802.11n HT40 mode- chain 0

Low CH

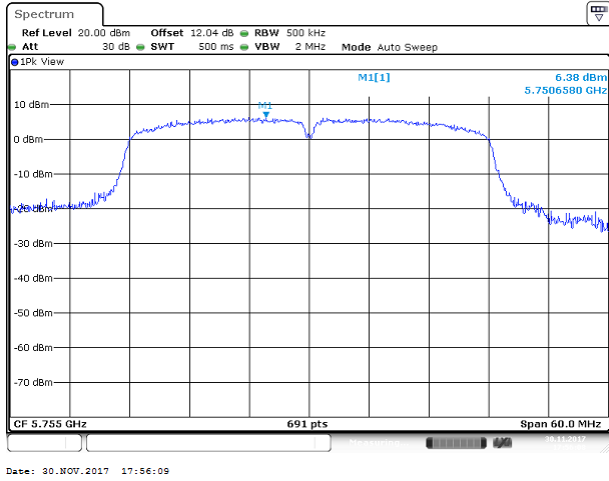

High CH

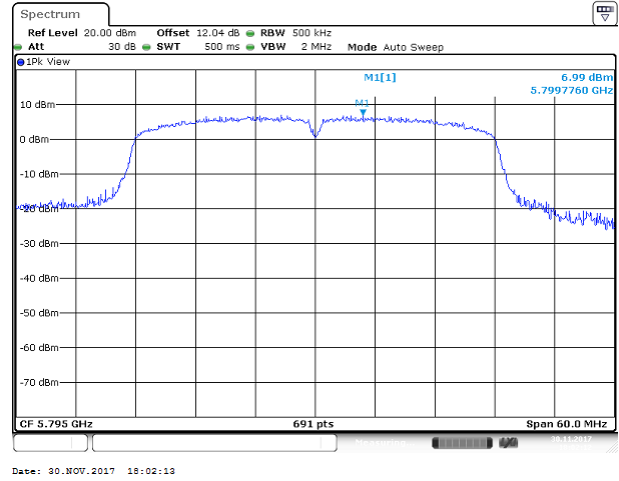

Cross CH

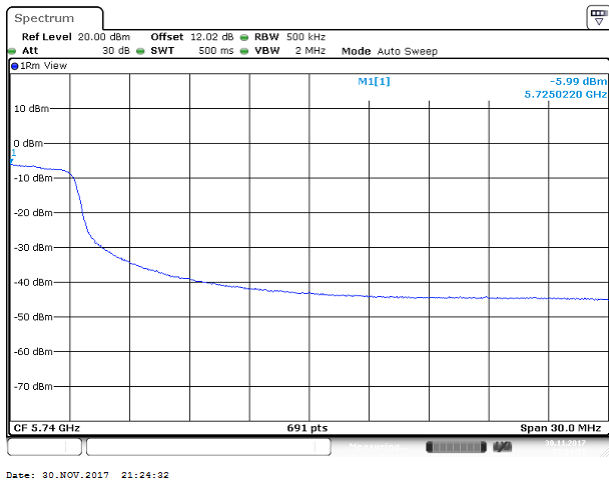

UNII-3 IEEE 802.11n HT40 mode- chain 1

Low CH

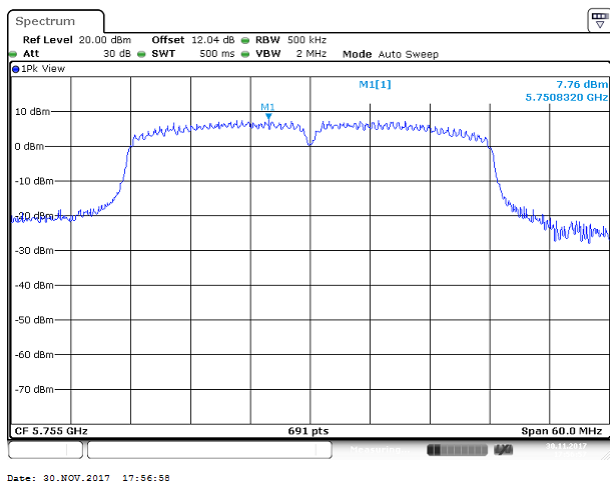

High CH

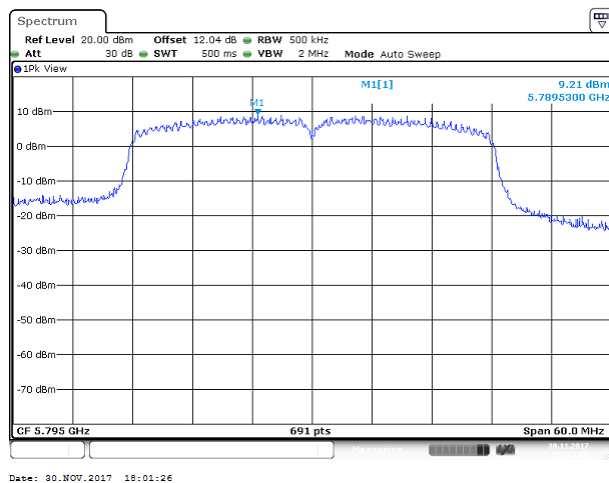

Cross CH

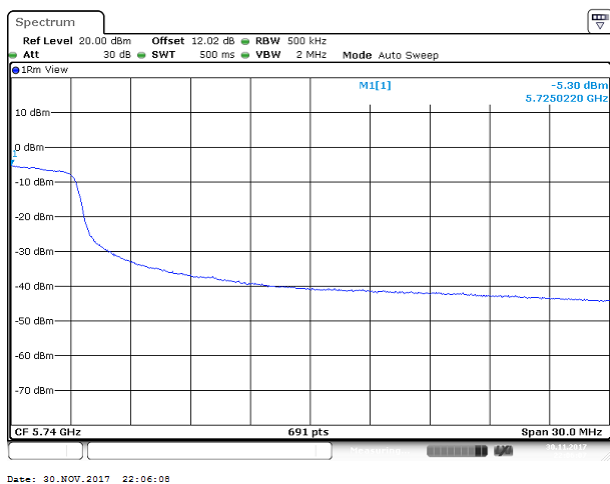

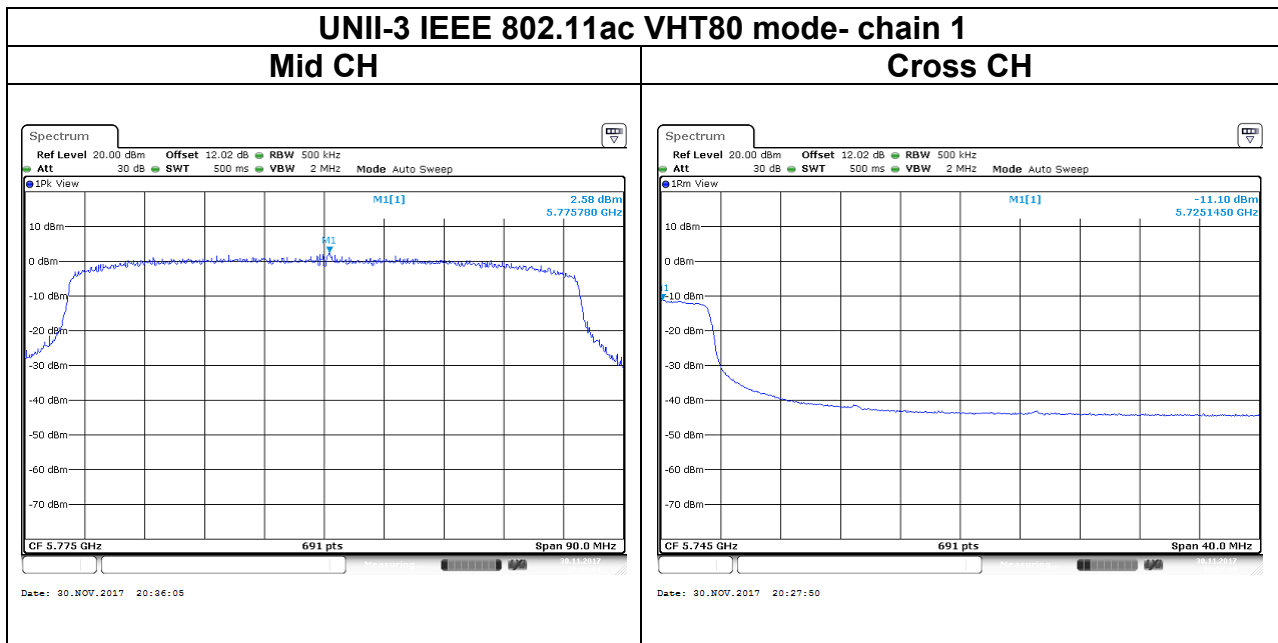
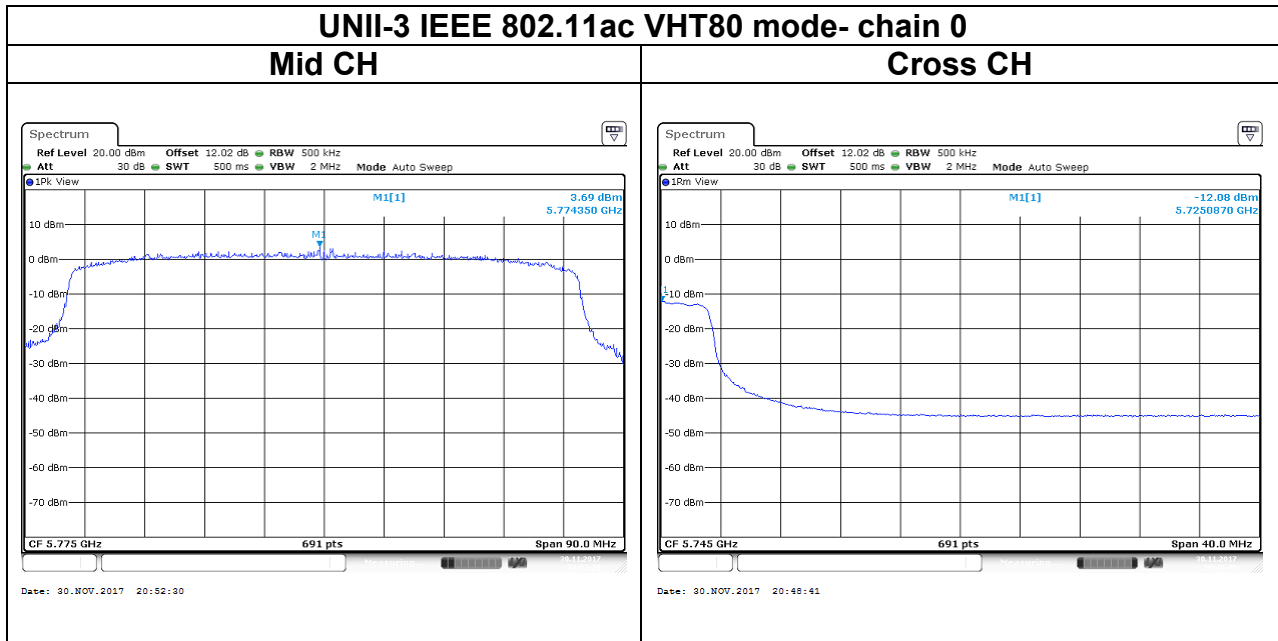

4.5 RADIATION BANDEDGE AND SPURIOUS EMISSION

4.5.1 Test Limit

FCC according to §15.407, §15.209 and §15.205,

Below 30 MHz

Frequency	Field Strength (microvolts/m)	Magnetic H-Field (microamperes/m)	Measurement Distance (metres)
9-490 kHz	2,400/F (F in kHz)	2,400/F (F in kHz)	300
490-1,705 kHz	24,000/F (F in kHz)	24,000/F (F in kHz)	30
1.705-30 MHz	30	N/A	30

Above 30 MHz

Frequency (MHz)	Field Strength microvolts/m at 3 metres (watts, e.i.r.p.)	
	Transmitters	Receivers
30-88	100 (3 nW)	100 (3 nW)
88-216	150 (6.8 nW)	150 (6.8 nW)
216-960	200 (12 nW)	200 (12 nW)
Above 960	500 (75 nW)	500 (75 nW)

IC according to RSS-247 section 6.2.1(2), section 6.2.2(2), section 6.2.3(2) and section 6.2.4(2)

UNII-1 :

For transmitters operating in the band 5150-5250 MHz, all emissions outside the band 5150-5350 MHz shall not exceed -27 dBm/MHz e.i.r.p. However, any unwanted emissions that fall into the band 5250-5350 MHz must be 26 dBc, when measured using a resolution bandwidth between 1 and 5% of the occupied bandwidth, above 5.25 GHz. Otherwise, the transmission is considered as intentional and the devices shall implement dynamic frequency selection (DFS) and transmitter power control (TPC) as per the requirements for the band 5250-5350 MHz

UNII-2a and 2c :

For devices with operating frequencies in the band 5250-5350 MHz but having a channel bandwidth that overlaps the band 5150-5250 MHz, the devices' unwanted emission shall not exceed -27 dBm/MHz e.i.r.p. outside the band 5150-5350 MHz and its power shall comply with the spectral power density for operation within the band 5150-5250 MHz. The device shall be labelled "for indoor use only." Emissions outside the band 5470-5725 MHz shall not exceed -27 dBm/MHz e.i.r.p.

UNII-3:

All emissions shall be limited to a level of -27 dBm/MHz at 75 MHz or more above or below the band edge increasing linearly to 10 dBm/MHz at 25 MHz above or below the band edge, and from 25 MHz above or below the band edge increasing linearly to a level of 15.6 dBm/MHz at 5 MHz above or below the band edge, and from 5 MHz above or below the band edge increasing linearly to a level of 27 dBm/MHz at the band edge.

4.5.2 Test Procedure

Test method Refer as KDB 789033 D02 v01r04, Section G.3, G.4, G.5, and G.6,.

1. The EUT is placed on a turntable, Above 1 GHz is 1.5m and below 1 GHz is 0.8m above ground plane. The EUT Configured un accordance with ANSI C63.10, and the EUT set in a continuous mode.
2. The turntable shall be rotated for 360 degrees to determine the position of maximum emission level. And EUT is set 3m away from the receiving antenna, which is scanned from 1m to 4m above the ground plane to find out the highest emissions. Measurement are made polarized in both the vertical and the horizontal positions with antenna.
3. Span shall wide enough to full capture the emission measured. The SA from 30MHz to 26.5GHz set to the low, Mid and High channels with the EUT transmit.
5. The SA setting following :
 - (1) Below 1G : RBW = 100kHz, VBW \geq 3*RBW, Sweep = Auto, Detector = Peak, Trace = Max hold.
 - (2) Above 1G :
 - (2.1) For Peak measurement : RBW = 1MHz, VBW \geq 3 RBW, Sweep = Auto, Detector = Peak, Trace = Max hold.
 - (2.2) For Average measurement : RBW = 1MHz, VBW
 - If Duty Cycle \geq 98%, VBW=10Hz.
 - If Duty Cycle < 98%, VBW=1/T.

Configuration	Duty Cycle (%)	T(ms)	1/T (kHz)	VBW Setting
802.11a	97%	1.4800	675.676	680Hz
802.11n HT20	95%	0.7200	1388.889	1.5KHz
802.11n HT40	87%	0.3900	2564.103	2.7KHz
802.11ac VHT80	92%	0.1200	8333.333	9.1KHz

4.5.3 Test Setup

9kHz ~ 30MHz

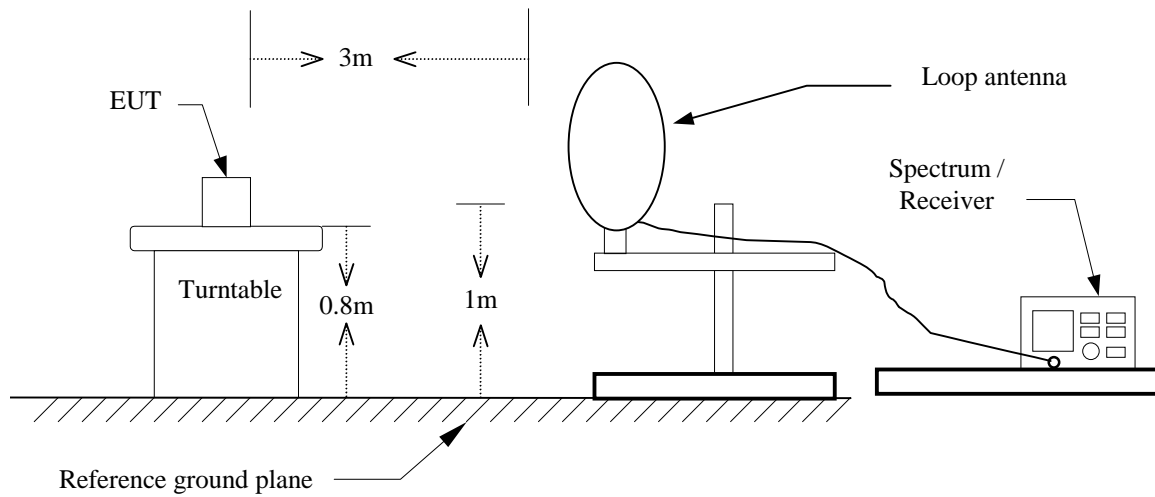

30MHz ~ 1GHz

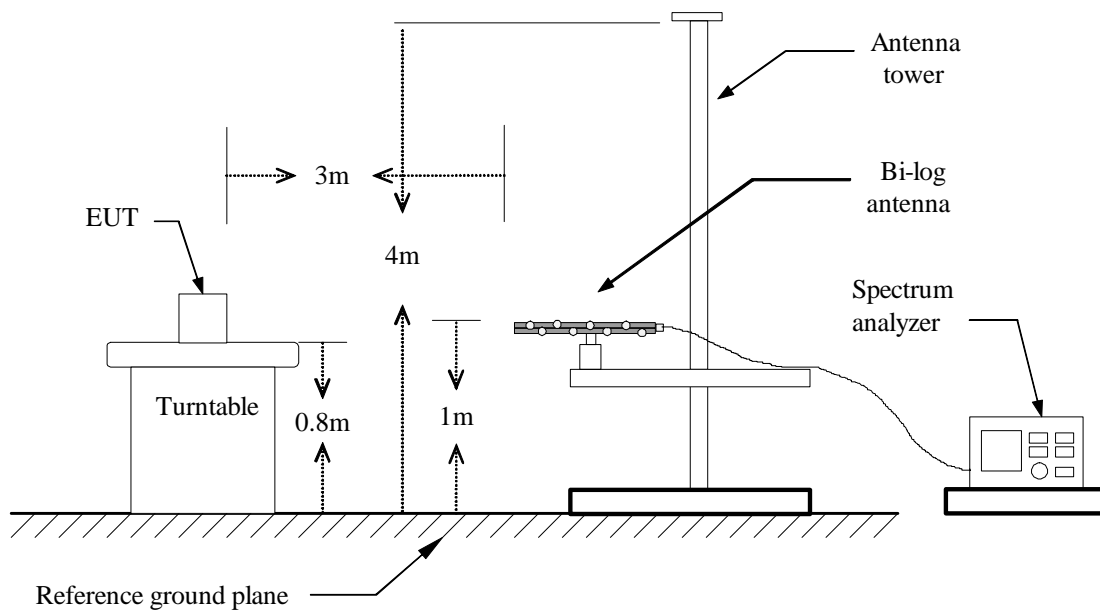

Above 1 GHz

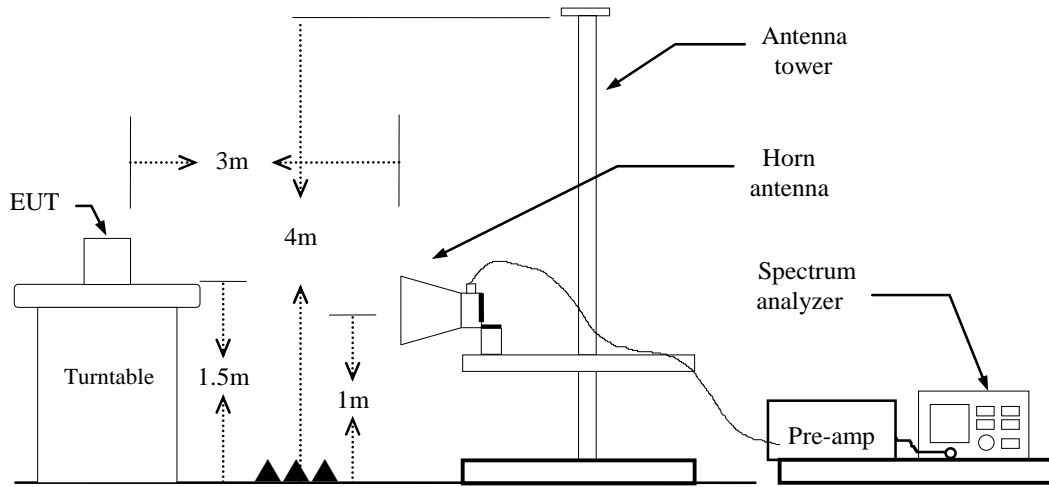

4.5.4 Test Result

Test Data

Band Edge Test Data for UNII-1

Test Mode	IEEE 802.11a / 5180MHZ	Temp/Hum	24(°C)/ 33%RH
Test Item	Band Edge	Test Date	November 28, 2017
Polarize	Vertical	Test Engineer	Jerry Chuang
Detector	Peak	Test Voltage	120Vac / 60Hz

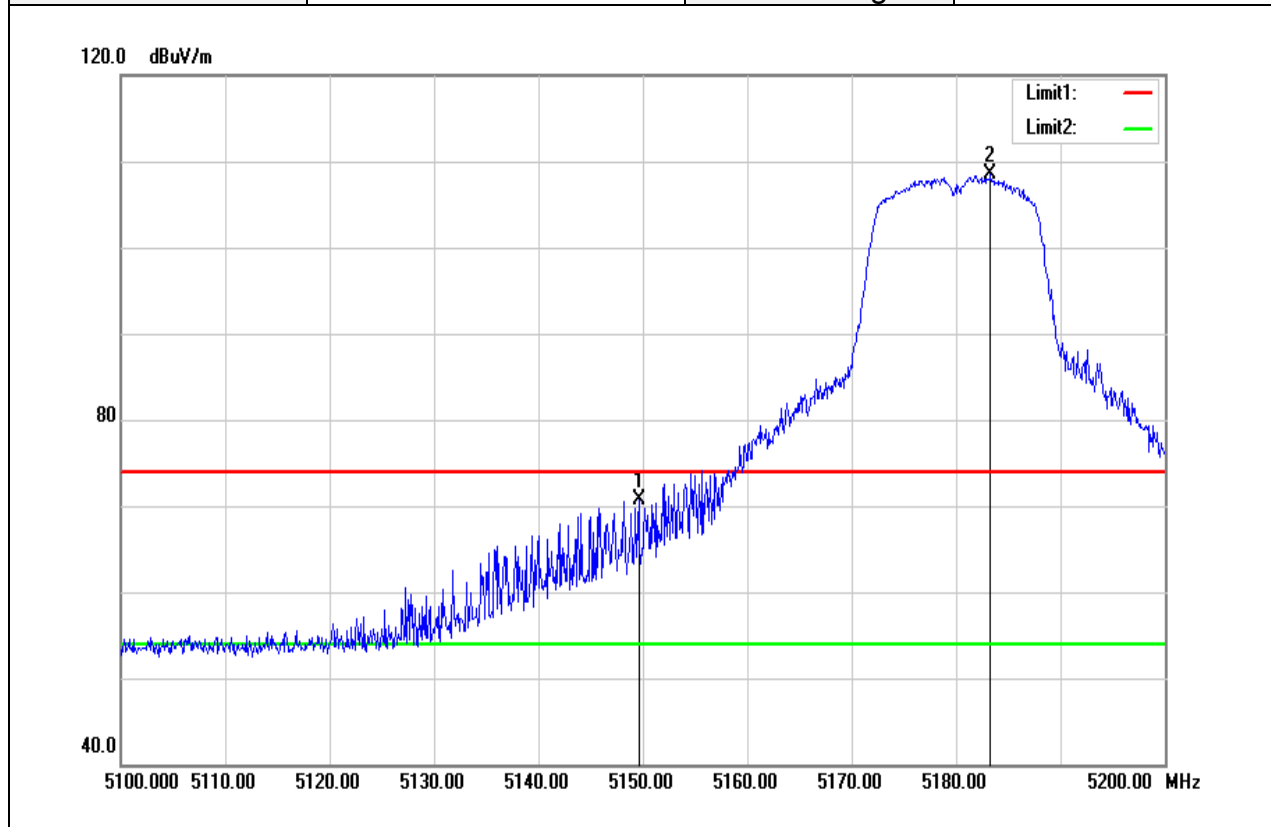

Frequency (MHz)	Reading (dBuV)	Correct Factor (dB/m)	Result (dBuV/m)	Limit (dBuV/m)	Margin (dB)	Remark
5149.600	65.64	5.06	70.70	74.00	-3.30	peak
5183.300	103.29	5.14	108.43	-	-	peak

Test Mode	IEEE 802.11a / 5180MHZ	Temperature	24(°C)/ 33%RH
Test Item	Band Edge	Test Date	November 28, 2017
Polarize	Vertical	Test Engineer	Jerry Chuang
Detector	Average	Test Voltage	120Vac / 60Hz

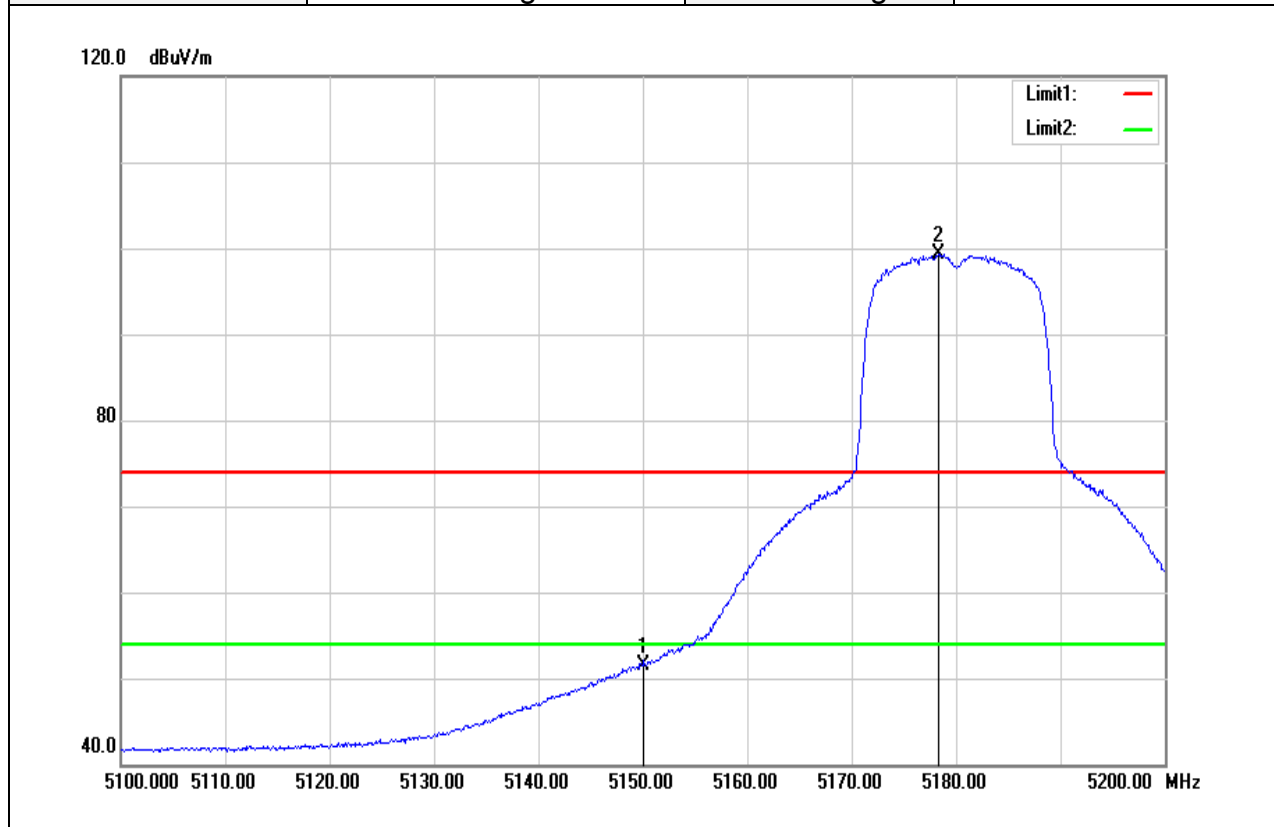

Frequency (MHz)	Reading (dBuV)	Correct Factor (dB/m)	Result (dBuV/m)	Limit (dBuV/m)	Margin (dB)	Remark
5150.000	46.53	5.06	51.59	54.00	-2.41	AVG
5178.300	94.12	5.14	99.26	-	-	AVG

Test Mode	IEEE 802.11a / 5240MHZ	Temp/Hum	24(°C)/ 33%RH
Test Item	Band Edge	Test Date	November 28, 2017
Polarize	Vertical	Test Engineer	Jerry Chuang
Detector	Peak	Test Voltage	120Vac / 60Hz

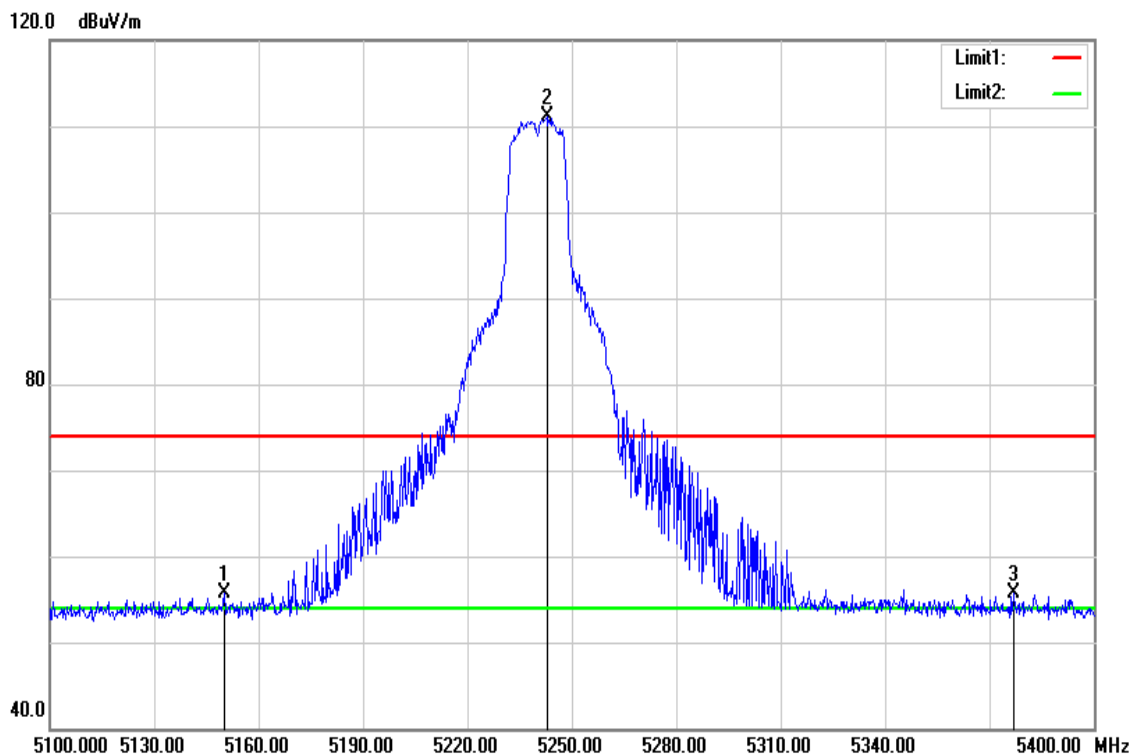

Frequency (MHz)	Reading (dBuV)	Correct Factor (dB/m)	Result (dBuV/m)	Limit (dBuV/m)	Margin (dB)	Remark
5150.000	50.60	5.06	55.66	74.00	-18.34	peak
5242.800	105.75	5.29	111.04	-	-	peak
5376.900	50.11	5.63	55.74	74.00	-18.26	peak

Test Mode	IEEE 802.11a / 5240MHZ	Temp/Hum	24(°C)/ 33%RH
Test Item	Band Edge	Test Date	November 28, 2017
Polarize	Vertical	Test Engineer	Jerry Chuang
Detector	Average	Test Voltage	120Vac / 60Hz

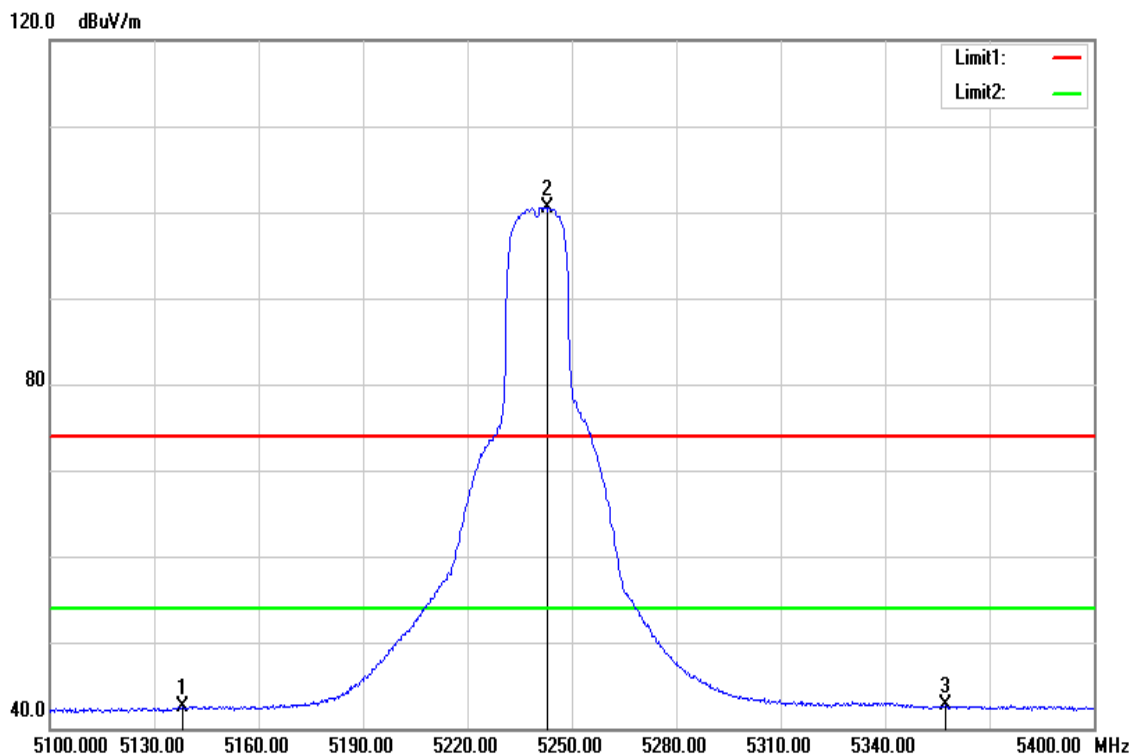

Frequency (MHz)	Reading (dBuV)	Correct Factor (dB/m)	Result (dBuV/m)	Limit (dBuV/m)	Margin (dB)	Remark
5138.100	37.50	5.03	42.53	54.00	-11.47	AVG
5242.800	95.27	5.29	100.56	-	-	AVG
5357.400	37.09	5.57	42.66	54.00	-11.34	AVG

Test Mode	IEEE 802.11n HT20 / 5180MHZ	Temp/Hum	24(°C)/ 33%RH
Test Item	Band Edge	Test Date	November 28, 2017
Polarize	Vertical	Test Engineer	Jerry Chuang
Detector	Peak	Test Voltage	120Vac / 60Hz

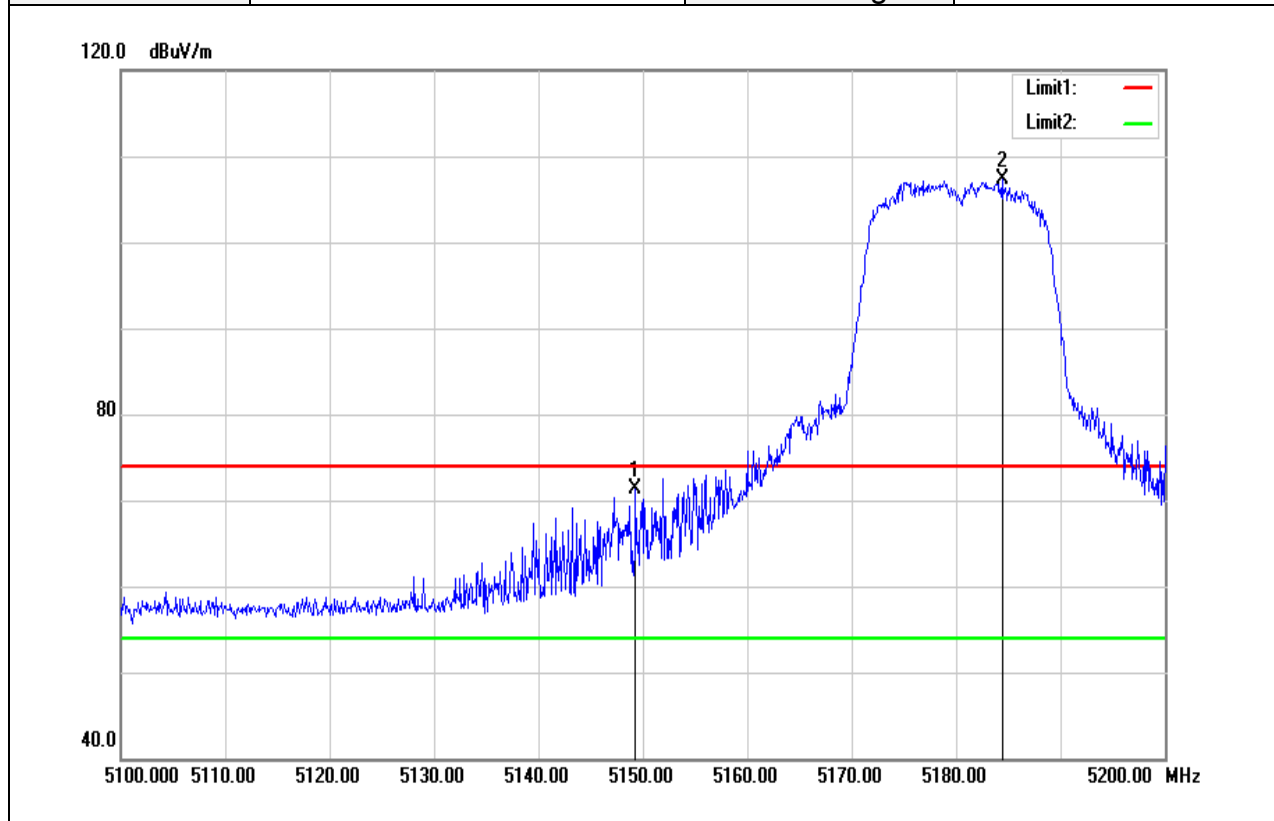

Frequency (MHz)	Reading (dBuV)	Correct Factor (dB/m)	Result (dBuV/m)	Limit (dBuV/m)	Margin (dB)	Remark
5149.300	66.30	5.06	71.36	74.00	-2.64	peak
5184.400	102.07	5.14	107.21	-	-	peak

Test Mode	IEEE 802.11n HT20 / 5180MHZ	Temp/Hum	24(°C)/ 33%RH
Test Item	Band Edge	Test Date	November 28, 2017
Polarize	Vertical	Test Engineer	Jerry Chuang
Detector	Average	Test Voltage	120Vac / 60Hz

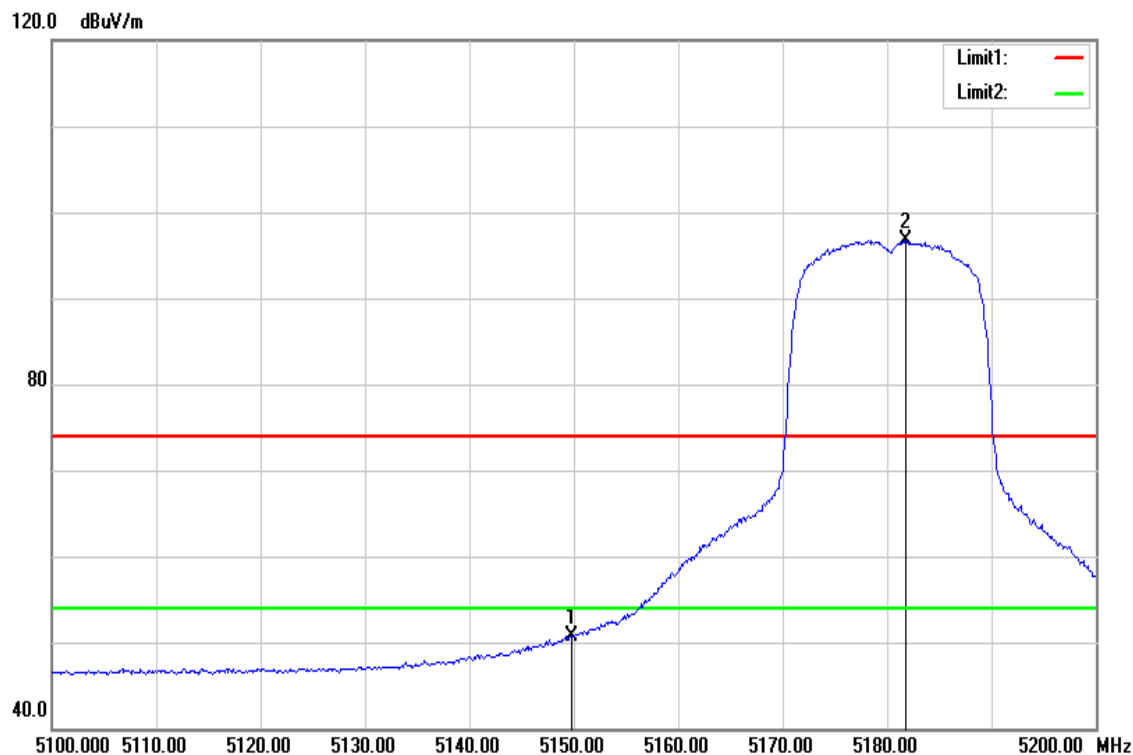

Frequency (MHz)	Reading (dBuV)	Correct Factor (dB/m)	Result (dBuV/m)	Limit (dBuV/m)	Margin (dB)	Remark
5149.800	45.73	5.06	50.79	54.00	-3.21	AVG
5181.800	91.58	5.14	96.72	-	-	AVG

Test Mode	IEEE 802.11n HT20 / 5240MHZ	Temp/Hum	24(°C)/ 33%RH
Test Item	Band Edge	Test Date	November 28, 2017
Polarize	Vertical	Test Engineer	Jerry Chuang
Detector	Peak	Test Voltage	120Vac / 60Hz

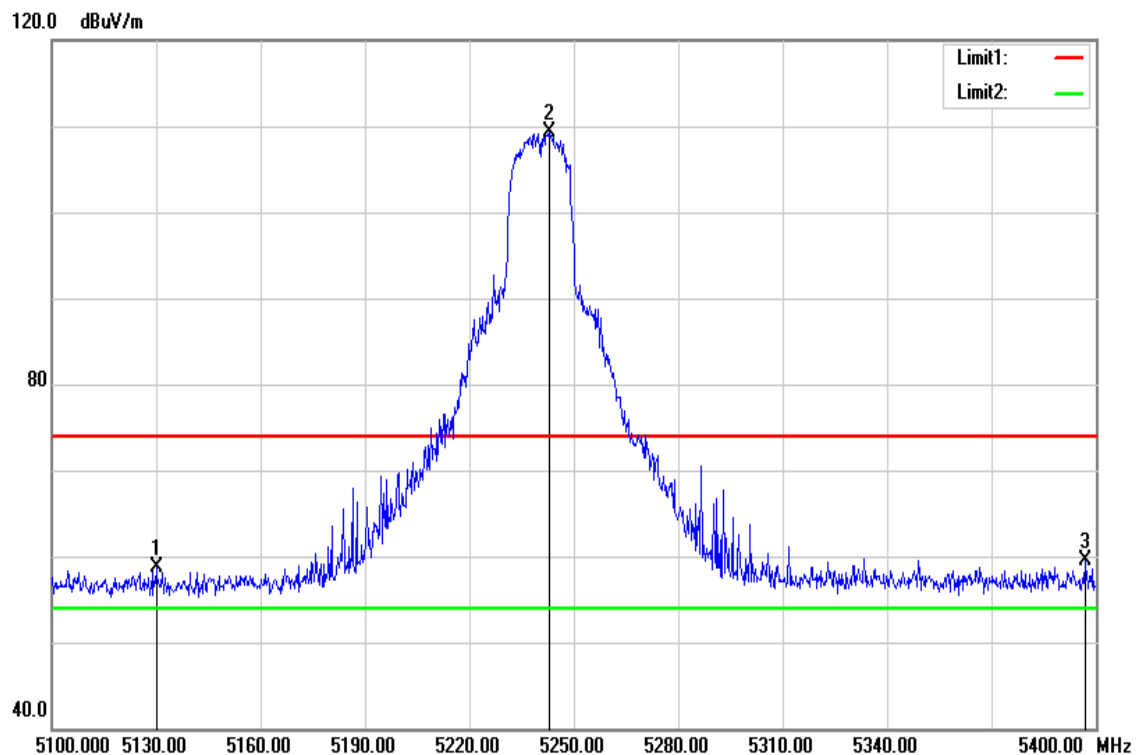

Frequency (MHz)	Reading (dBuV)	Correct Factor (dB/m)	Result (dBuV/m)	Limit (dBuV/m)	Margin (dB)	Remark
5130.000	53.76	5.01	58.77	74.00	-15.23	peak
5242.800	103.93	5.29	109.22	-	-	peak
5397.000	53.90	5.68	59.58	74.00	-14.42	peak

Test Mode	IEEE 802.11n HT20 / 5240MHZ	Temperature	24(°C)/ 33%RH
Test Item	Band Edge	Test Date	November 28, 2017
Polarize	Vertical	Test Engineer	Jerry Chuang
Detector	Average	Test Voltage	120Vac / 60Hz

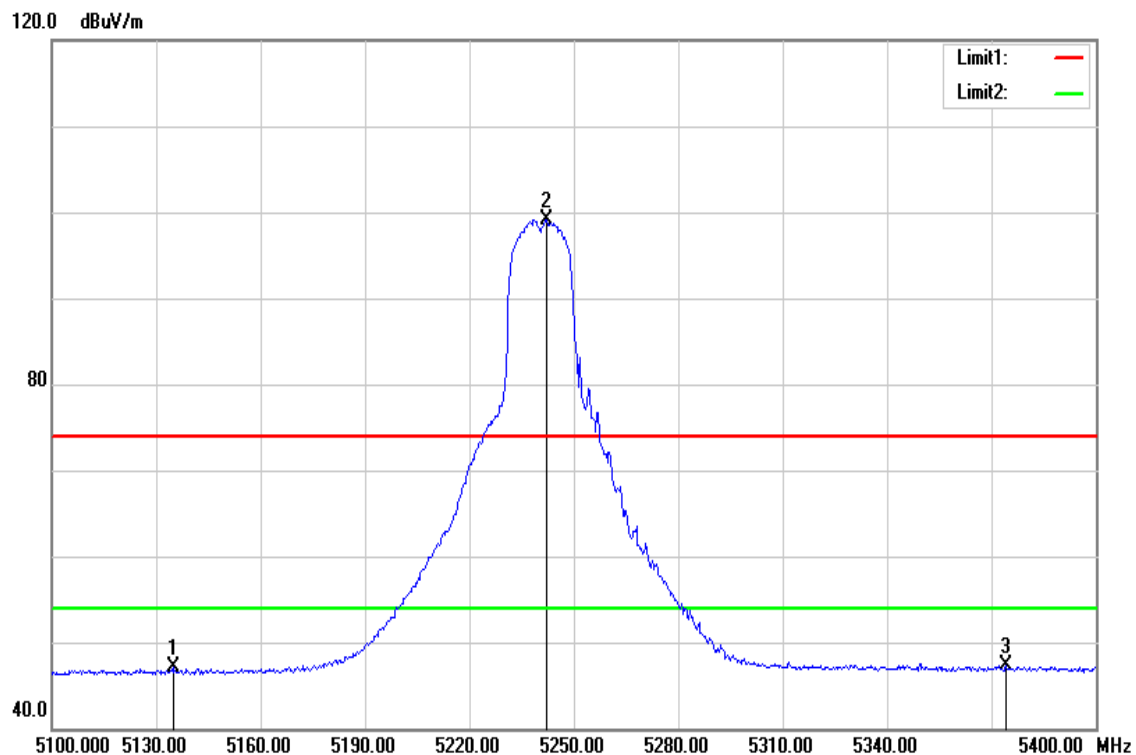

Frequency (MHz)	Reading (dBuV)	Correct Factor (dB/m)	Result (dBuV/m)	Limit (dBuV/m)	Margin (dB)	Remark
5134.800	42.04	5.02	47.06	54.00	-6.94	AVG
5242.200	93.75	5.29	99.04	-	-	AVG
5374.200	41.70	5.61	47.31	54.00	-6.69	AVG

Test Mode	IEEE 802.11n HT40 / 5190MHZ	Temp/Hum	24(°C)/ 33%RH
Test Item	Band Edge	Test Date	November 28, 2017
Polarize	Vertical	Test Engineer	Jerry Chuang
Detector	Peak	Test Voltage	120Vac / 60Hz

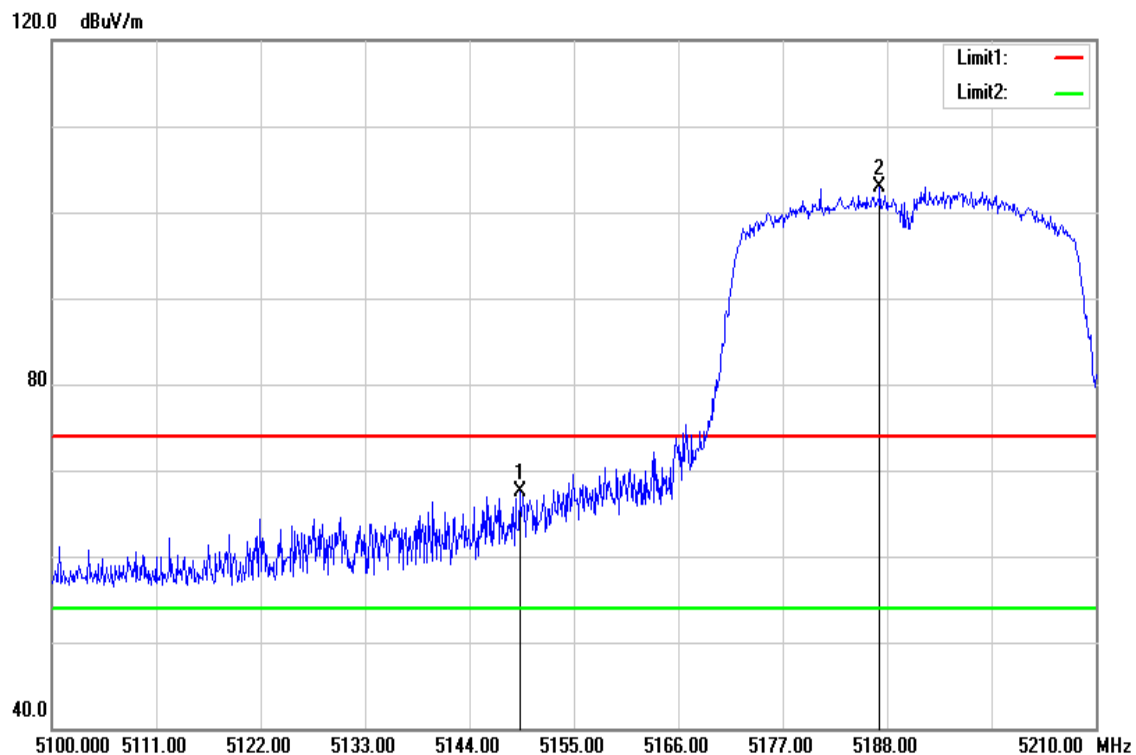

Frequency (MHz)	Reading (dBuV)	Correct Factor (dB/m)	Result (dBuV/m)	Limit (dBuV/m)	Margin (dB)	Remark
5149.280	62.50	5.06	67.56	74.00	-6.44	peak
5187.230	97.83	5.15	102.98	-	-	peak

Test Mode	IEEE 802.11n HT40 / 5190MHZ	Temperature	24(°C)/ 33%RH
Test Item	Band Edge	Test Date	November 28, 2017
Polarize	Vertical	Test Engineer	Jerry Chuang
Detector	Average	Test Voltage	120Vac / 60Hz

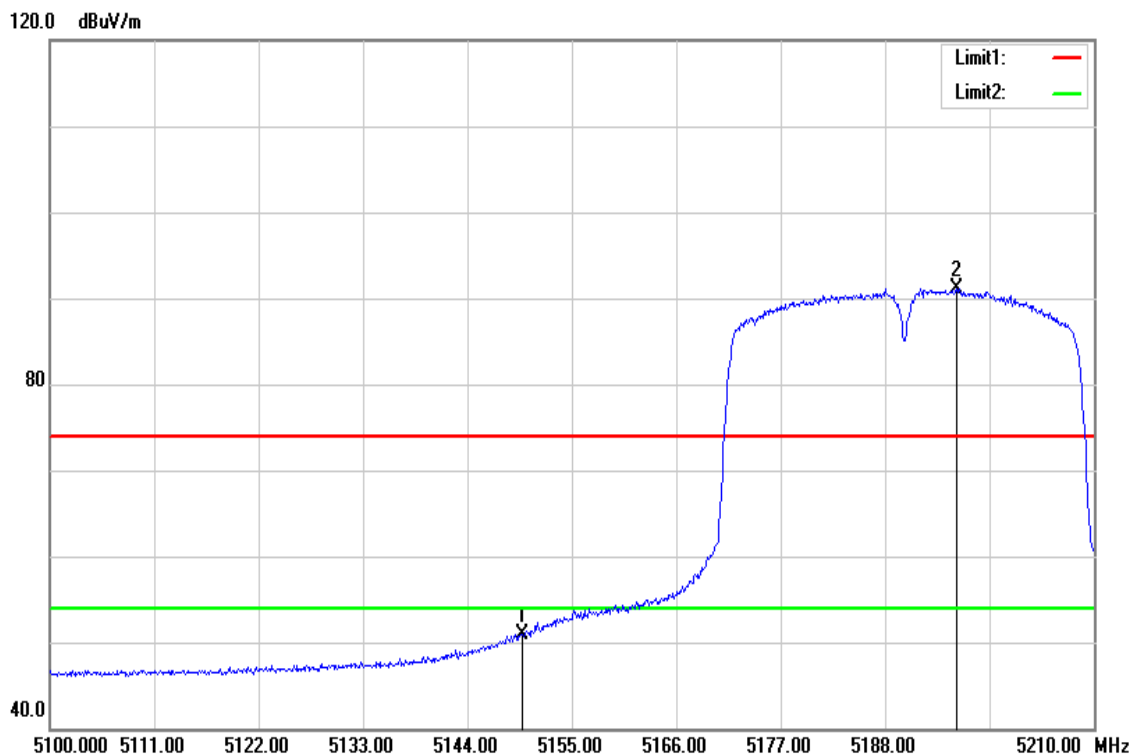

Frequency (MHz)	Reading (dBuV)	Correct Factor (dB/m)	Result (dBuV/m)	Limit (dBuV/m)	Margin (dB)	Remark
5149.830	45.81	5.06	50.87	54.00	-3.13	AVG
5195.480	85.95	5.18	91.13	-	-	AVG

Test Mode	IEEE 802.11n HT40 / 5230MHZ	Temp/Hum	24(°C)/ 33%RH
Test Item	Band Edge	Test Date	November 28, 2017
Polarize	Vertical	Test Engineer	Jerry Chuang
Detector	Peak	Test Voltage	120Vac / 60Hz

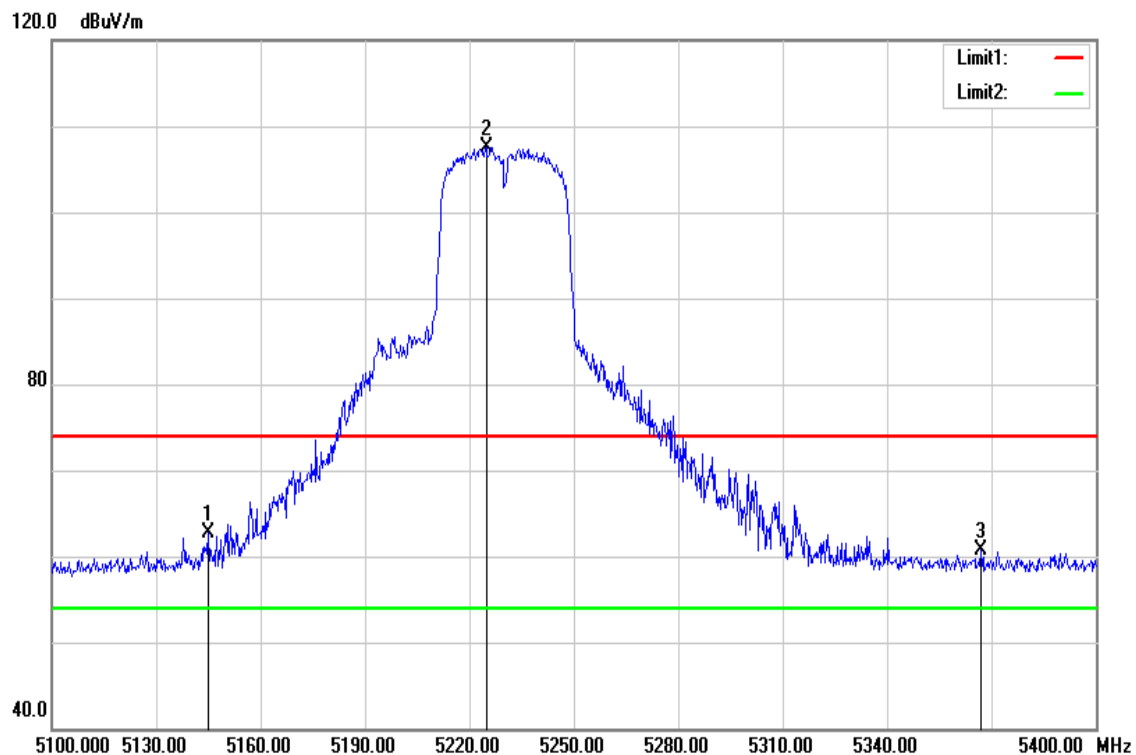

Frequency (MHz)	Reading (dBuV)	Correct Factor (dB/m)	Result (dBuV/m)	Limit (dBuV/m)	Margin (dB)	Remark
5145.000	57.57	5.06	62.63	74.00	-11.37	peak
5224.800	102.29	5.24	107.53	-	-	peak
5367.000	55.07	5.60	60.67	74.00	-13.33	peak

Test Mode	IEEE 802.11n HT40 / 5230MHZ	Temp/Hum	24(°C)/ 33%RH
Test Item	Band Edge	Test Date	November 28, 2017
Polarize	Vertical	Test Engineer	Jerry Chuang
Detector	Average	Test Voltage	120Vac / 60Hz

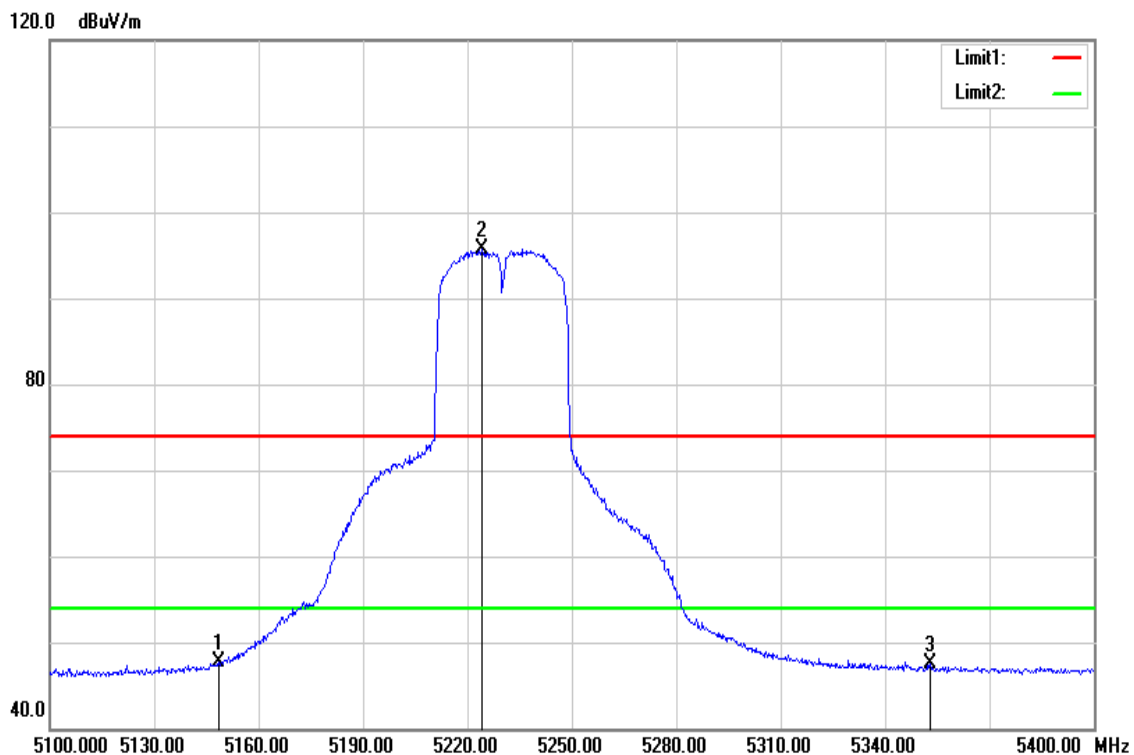

Frequency (MHz)	Reading (dBuV)	Correct Factor (dB/m)	Result (dBuV/m)	Limit (dBuV/m)	Margin (dB)	Remark
5148.600	42.58	5.06	47.64	54.00	-6.36	AVG
5224.200	90.42	5.24	95.66	-	-	AVG
5352.900	41.85	5.56	47.41	54.00	-6.59	AVG

Test Mode	IEEE 802.11ac VHT80 / 5210MHz	Temp/Hum	24(°C)/ 33%RH
Test Item	Band Edge	Test Date	November 28, 2017
Polarize	Vertical	Test Engineer	Jerry Chuang
Detector	Peak	Test Voltage	120Vac / 60Hz

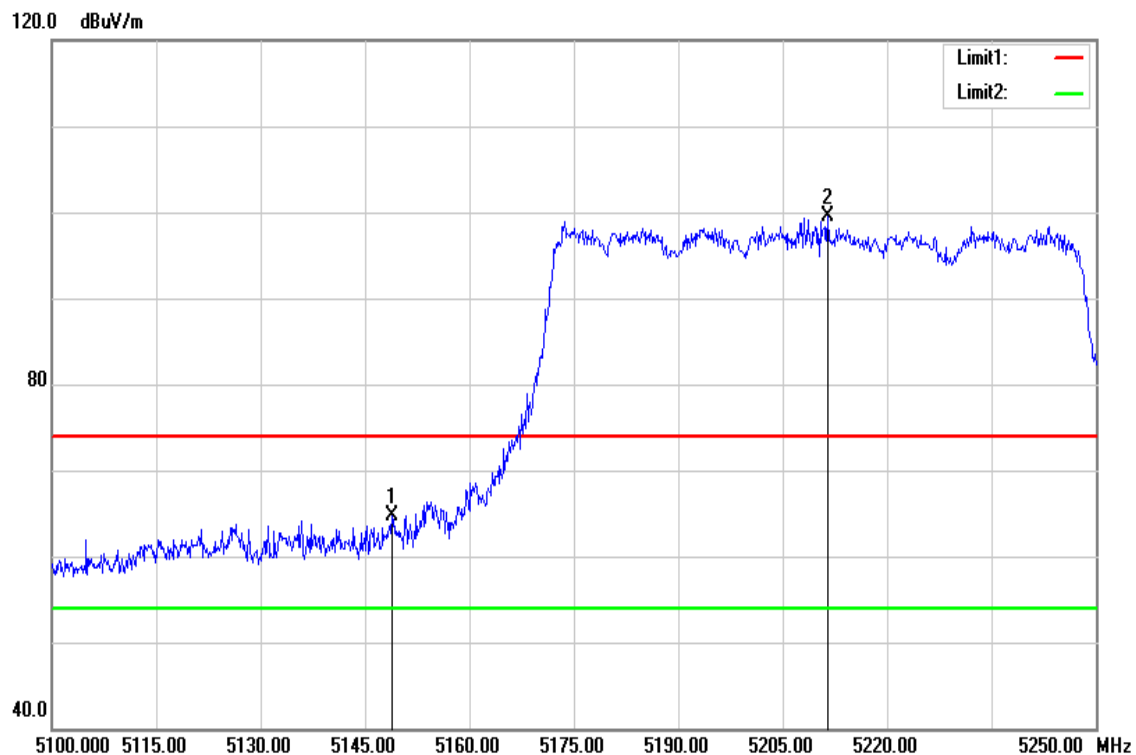

Frequency (MHz)	Reading (dBuV)	Correct Factor (dB/m)	Result (dBuV/m)	Limit (dBuV/m)	Margin (dB)	Remark
5148.900	59.58	5.06	64.64	74.00	-9.36	peak
5211.450	94.27	5.22	99.49	-	-	peak

Test Mode	I EEE 802.11ac VHT80 / 5210MHZ	Temp/Hum	24(°C)/ 33%RH
Test Item	Band Edge	Test Date	November 28, 2017
Polarize	Vertical	Test Engineer	Jerry Chuang
Detector	Average	Test Voltage	120Vac / 60Hz

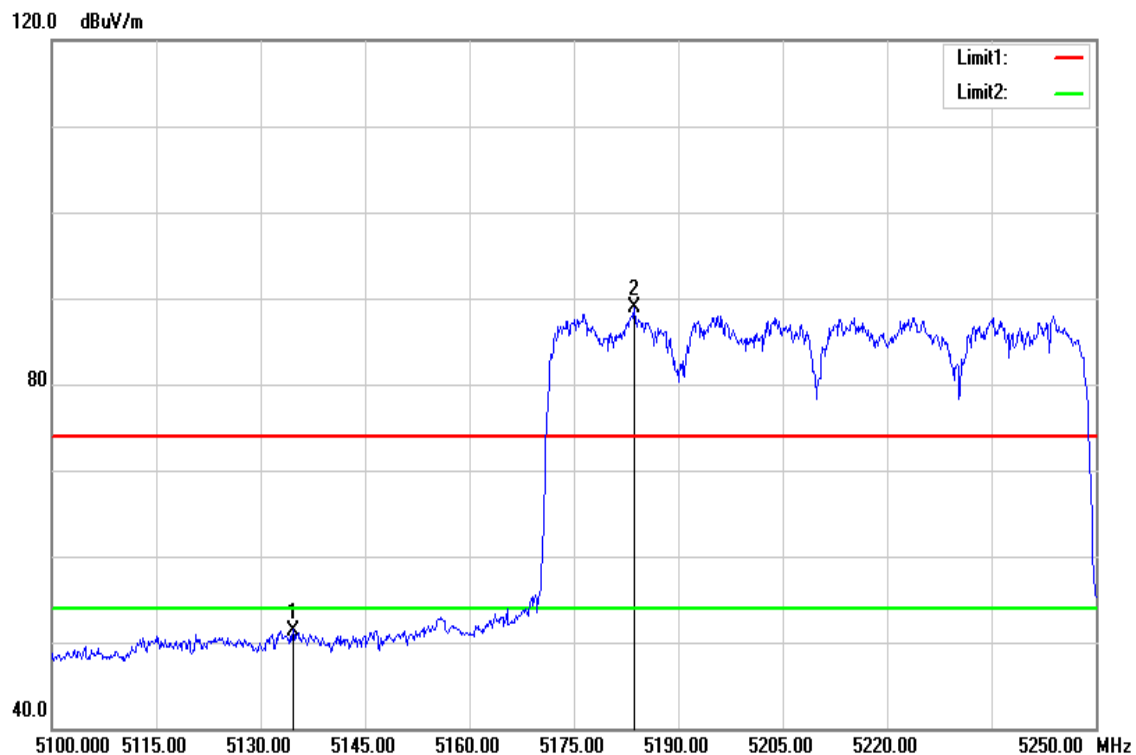

Frequency (MHz)	Reading (dBuV)	Correct Factor (dB/m)	Result (dBuV/m)	Limit (dBuV/m)	Margin (dB)	Remark
5134.650	46.38	5.02	51.40	54.00	-2.60	AVG
5183.700	83.73	5.14	88.87	-	-	AVG

Band Edge Test Data for UNII-2a

Test Mode	IEEE 802.11a / 5260 MHz	Temp/Hum	24(°C)/ 33%RH
Test Item	Band Edge	Test Date	November 28, 2017
Polarize	Vertical	Test Engineer	Jerry Chuang
Detector	Peak	Test Voltage	120Vac / 60Hz

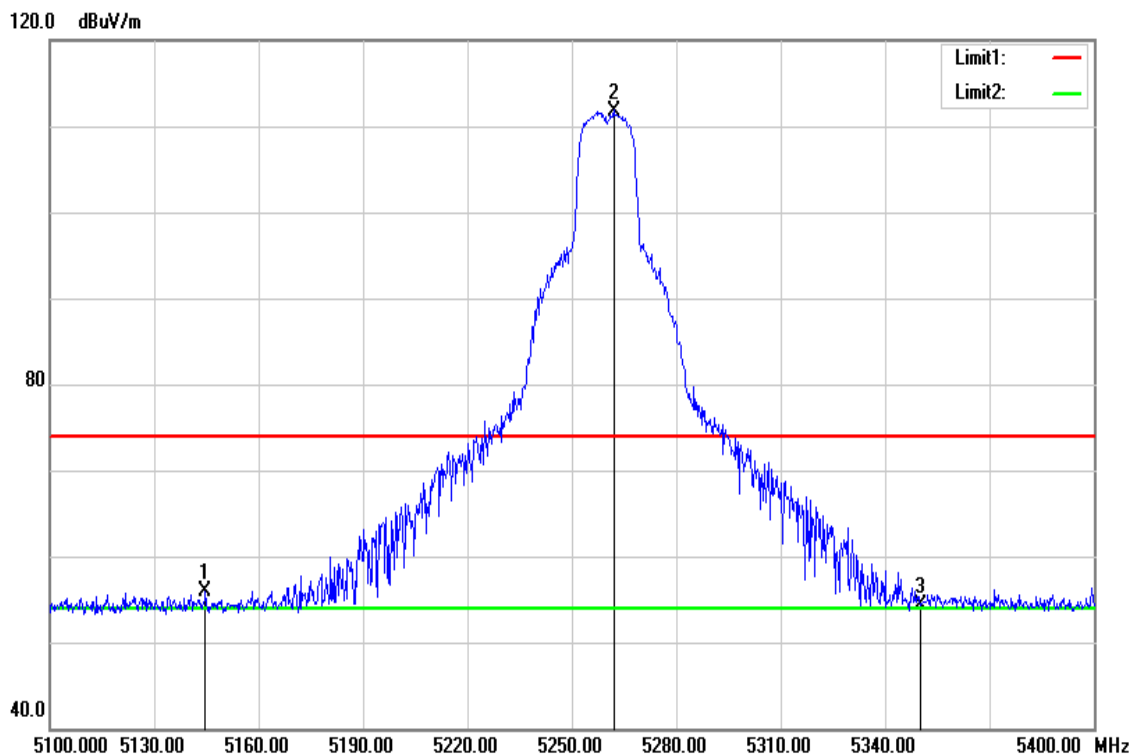

Frequency (MHz)	Reading (dBuV)	Correct Factor (dB/m)	Result (dBuV/m)	Limit (dBuV/m)	Margin (dB)	Remark
5144.700	50.89	5.05	55.94	74.00	-18.06	peak
5262.000	106.46	5.34	111.80	-	-	peak
5350.000	48.67	5.56	54.23	74.00	-19.77	peak

Test Mode	IEEE 802.11a / 5260MHz	Temp/Hum	24(°C)/ 33%RH
Test Item	Band Edge	Test Date	November 28, 2017
Polarize	Vertical	Test Engineer	Jerry Chuang
Detector	Average	Test Voltage	120Vac / 60Hz

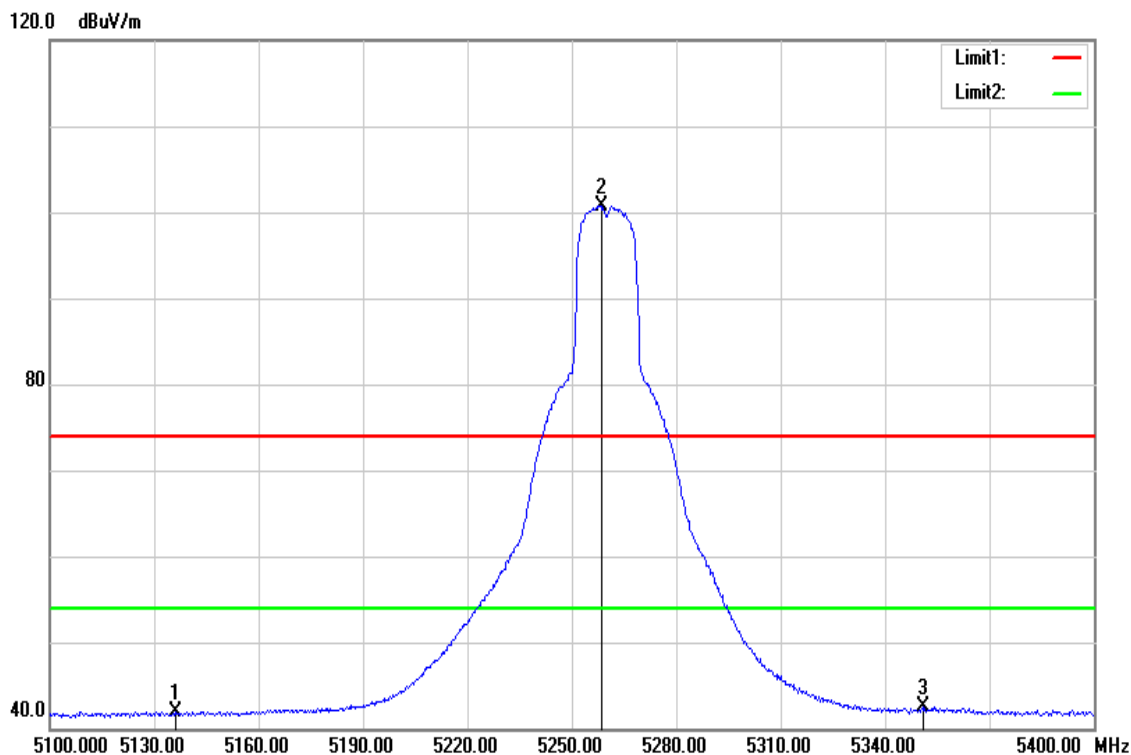

Frequency (MHz)	Reading (dBuV)	Correct Factor (dB/m)	Result (dBuV/m)	Limit (dBuV/m)	Margin (dB)	Remark
5136.000	36.92	5.03	41.95	54.00	-12.05	AVG
5258.400	95.45	5.34	100.79	-	-	AVG
5350.800	36.91	5.56	42.47	54.00	-11.53	AVG

Test Mode	IEEE 802.11a / 5320MHz	Temp/Hum	24(°C)/ 33%RH
Test Item	Band Edge	Test Date	November 28, 2017
Polarize	Vertical	Test Engineer	Jerry Chuang
Detector	Peak	Test Voltage	120Vac / 60Hz

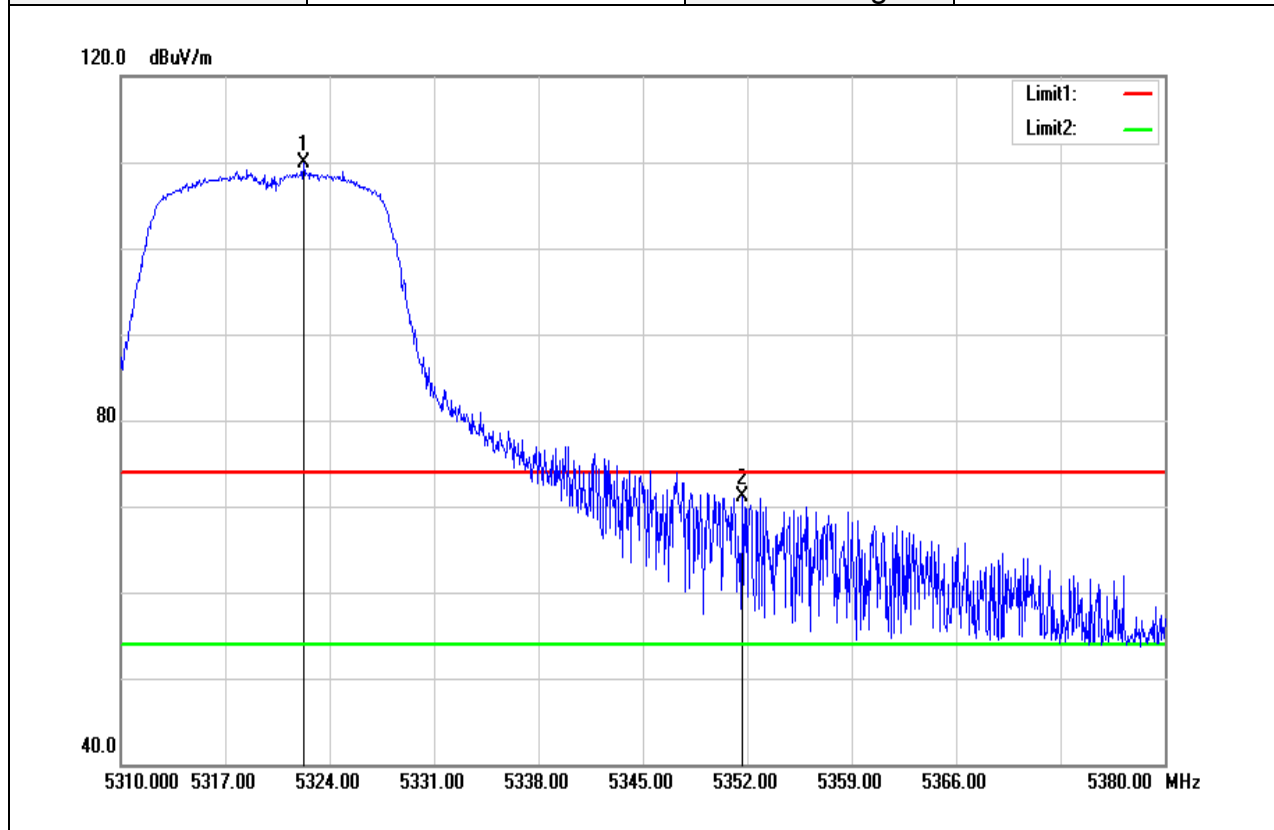

Frequency (MHz)	Reading (dBuV)	Correct Factor (dB/m)	Result (dBuV/m)	Limit (dBuV/m)	Margin (dB)	Remark
5322.250	104.48	5.48	109.96	-	-	peak
5351.650	65.54	5.56	71.10	74.00	-2.90	peak

Test Mode	IEEE 802.11a / 5320MHz	Temp/Hum	24(°C)/ 33%RH
Test Item	Band Edge	Test Date	November 28, 2017
Polarize	Vertical	Test Engineer	Jerry Chuang
Detector	Average	Test Voltage	120Vac / 60Hz

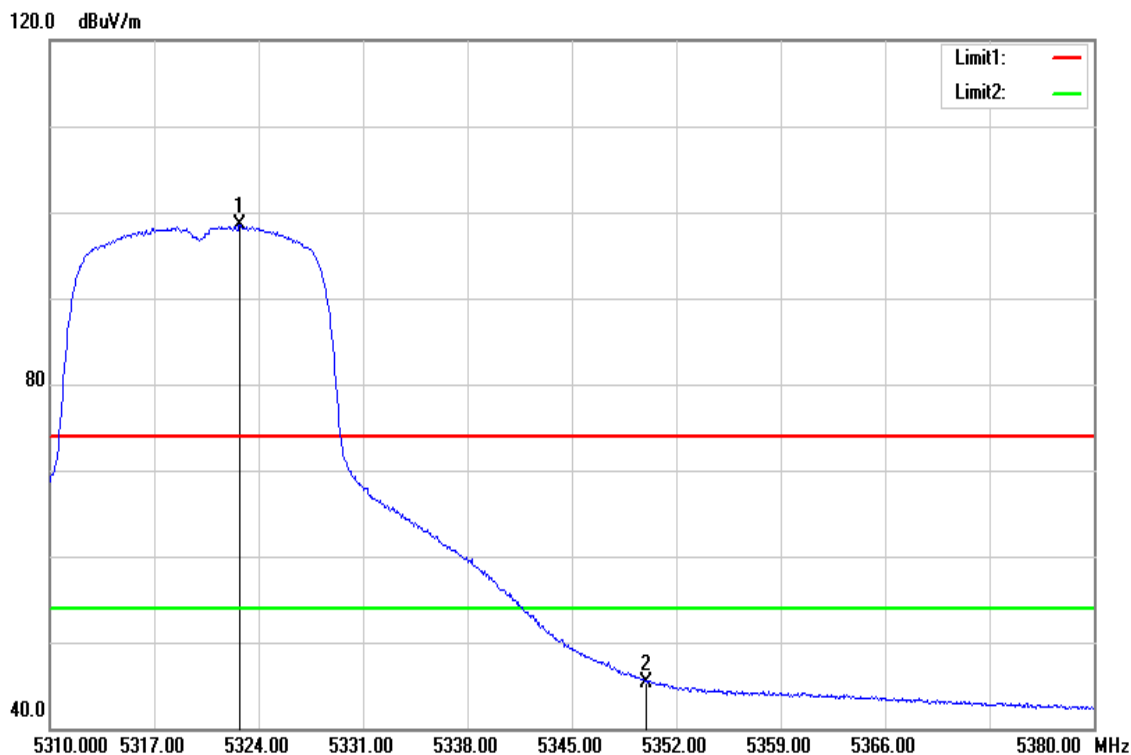

Frequency (MHz)	Reading (dBuV)	Correct Factor (dB/m)	Result (dBuV/m)	Limit (dBuV/m)	Margin (dB)	Remark
5322.740	93.04	5.48	98.52	-	-	AVG
5350.000	39.84	5.56	45.40	54.00	-8.60	AVG

Test Mode	IEEE 802.11n HT20 / 5260MHz	Temp/Hum	24(°C)/ 33%RH
Test Item	Band Edge	Test Date	November 28, 2017
Polarize	Vertical	Test Engineer	Jerry Chuang
Detector	Peak	Test Voltage	120Vac / 60Hz

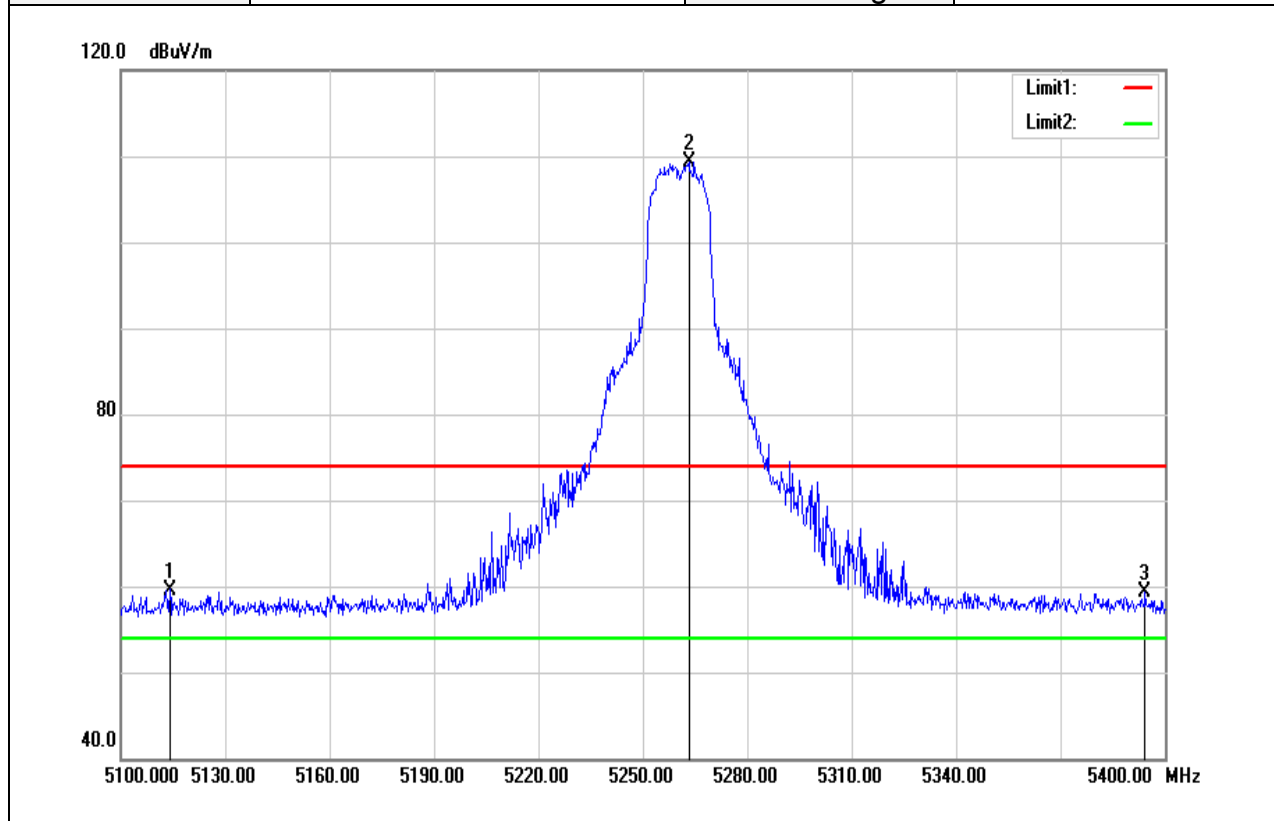

Frequency (MHz)	Reading (dBuV)	Correct Factor (dB/m)	Result (dBuV/m)	Limit (dBuV/m)	Margin (dB)	Remark
5114.100	54.63	4.97	59.60	74.00	-14.40	peak
5263.200	104.05	5.34	109.39	-	-	peak
5394.300	53.56	5.67	59.23	74.00	-14.77	peak

Test Mode	IEEE 802.11n HT20 / 5260MHz	Temp/Hum	24(°C)/ 33%RH
Test Item	Band Edge	Test Date	November 28, 2017
Polarize	Vertical	Test Engineer	Jerry Chuang
Detector	Average	Test Voltage	120Vac / 60Hz

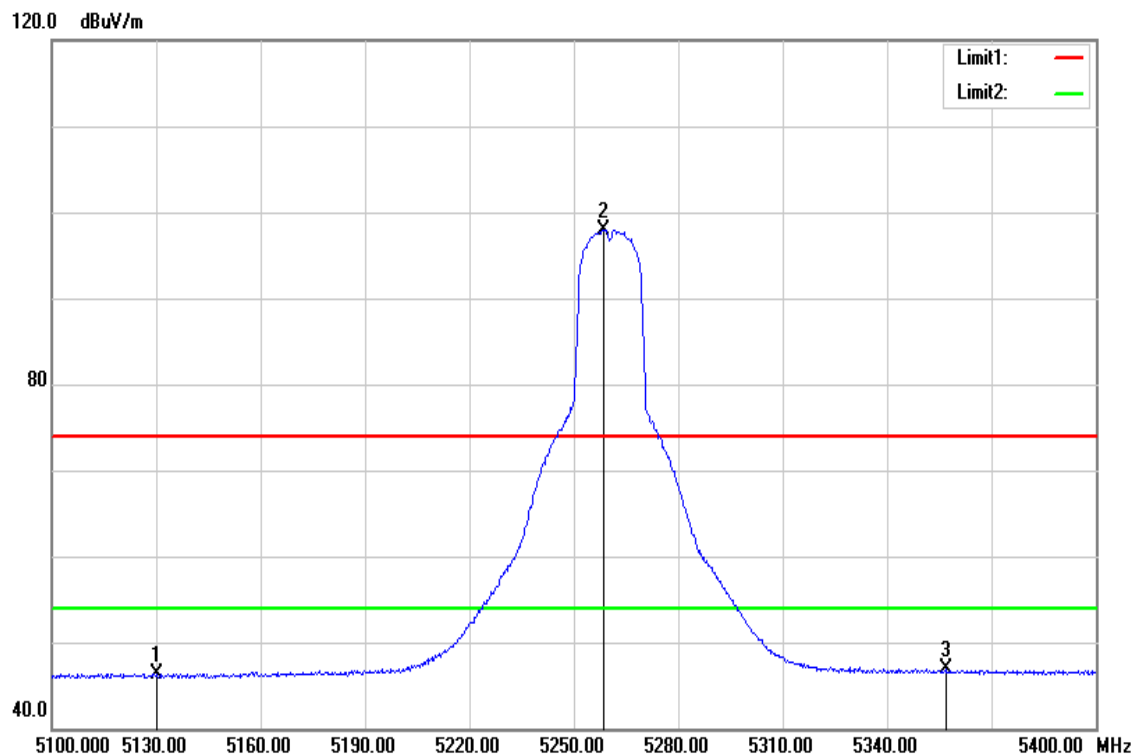

Frequency (MHz)	Reading (dBuV)	Correct Factor (dB/m)	Result (dBuV/m)	Limit (dBuV/m)	Margin (dB)	Remark
5130.300	41.38	5.01	46.39	54.00	-7.61	AVG
5258.400	92.63	5.34	97.97	-	-	AVG
5356.800	41.32	5.57	46.89	54.00	-7.11	AVG

Test Mode	IEEE 802.11n HT20 / 5320MHz	Temp/Hum	24(°C)/ 33%RH
Test Item	Band Edge	Test Date	November 28, 2017
Polarize	Vertical	Test Engineer	Jerry Chuang
Detector	Peak	Test Voltage	120Vac / 60Hz

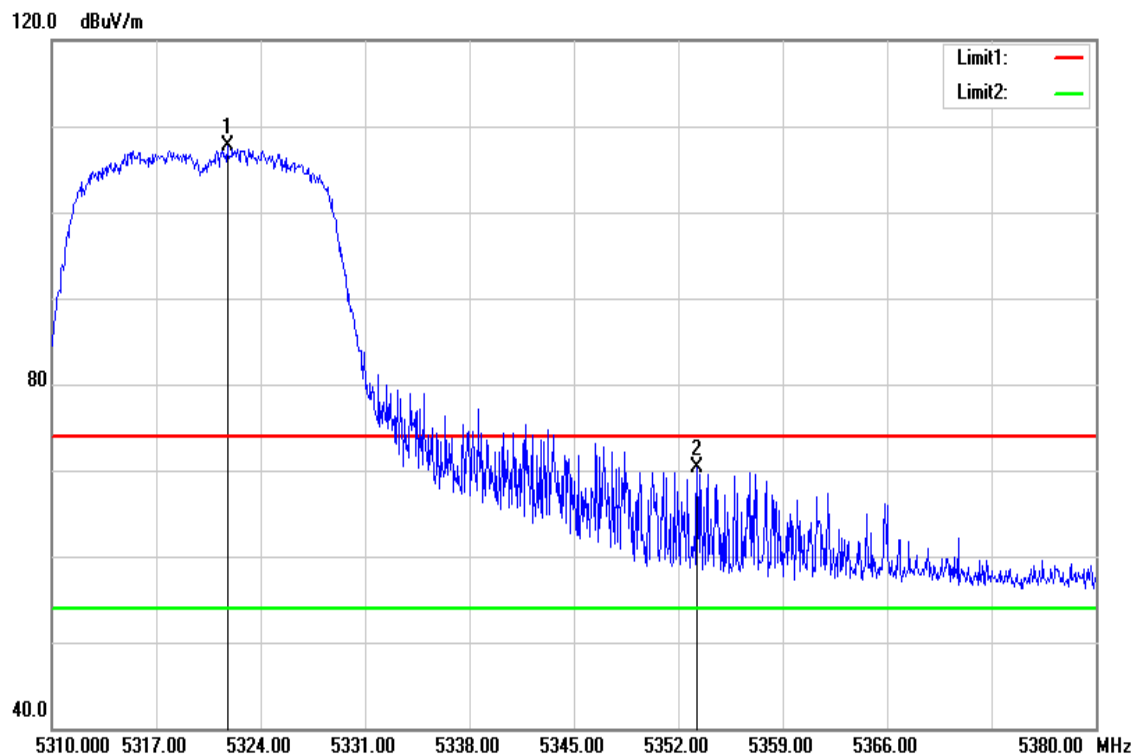

Frequency (MHz)	Reading (dBuV)	Correct Factor (dB/m)	Result (dBuV/m)	Limit (dBuV/m)	Margin (dB)	Remark
5321.760	102.19	5.48	107.67	-	-	peak
5353.260	64.73	5.56	70.29	74.00	-3.71	peak

Test Mode	IEEE 802.11n HT20 / 5320MHz	Temperature	24(°C)/ 33%RH
Test Item	Band Edge	Test Date	November 28, 2017
Polarize	Vertical	Test Engineer	Jerry Chuang
Detector	Average	Test Voltage	120Vac / 60Hz

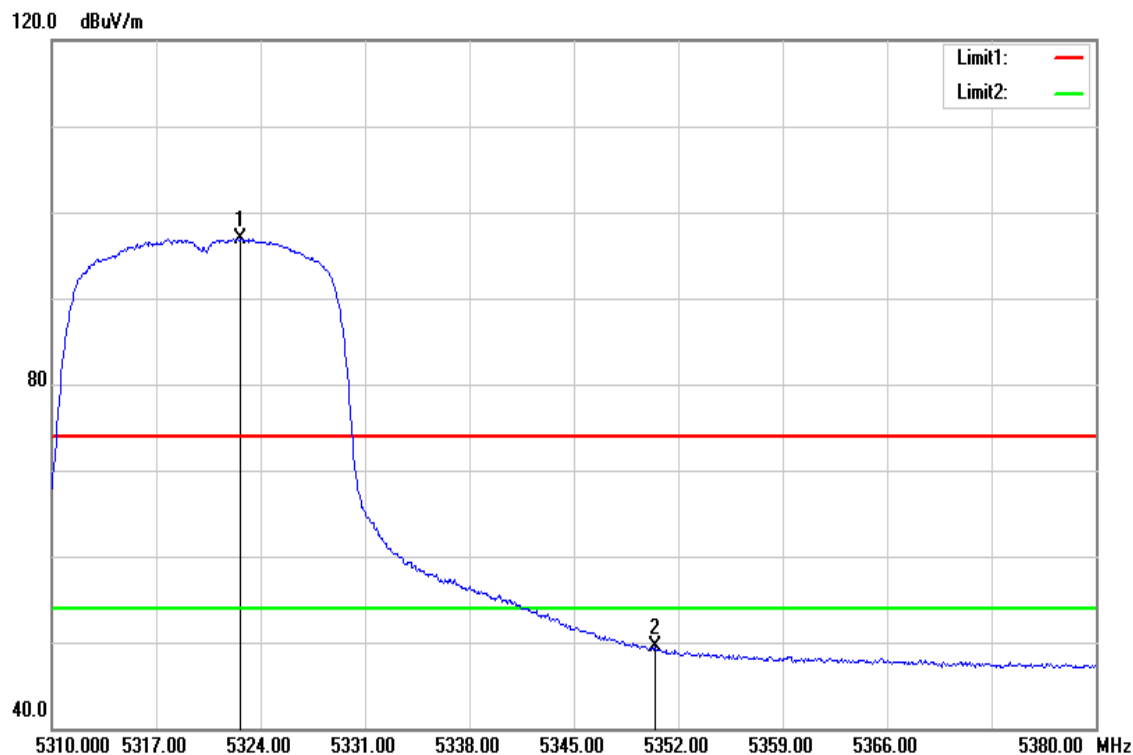

Frequency (MHz)	Reading (dBuV)	Correct Factor (dB/m)	Result (dBuV/m)	Limit (dBuV/m)	Margin (dB)	Remark
5322.670	91.43	5.48	96.91	-	-	AVG
5350.460	43.85	5.56	49.41	54.00	-4.59	AVG

Test Mode	IEEE 802.11n HT40 / 5270MHz	Temp/Hum	24(°C)/ 33%RH
Test Item	Band Edge	Test Date	November 28, 2017
Polarize	Vertical	Test Engineer	Jerry Chuang
Detector	Peak	Test Voltage	120Vac / 60Hz

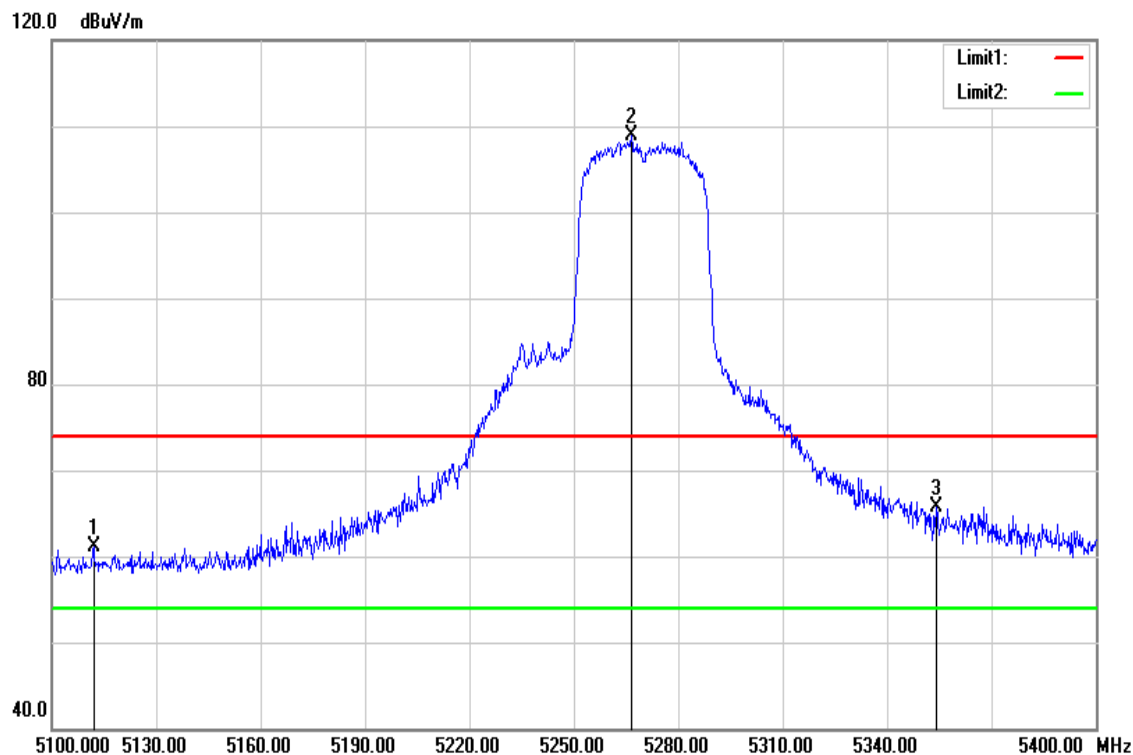

Frequency (MHz)	Reading (dBuV)	Correct Factor (dB/m)	Result (dBuV/m)	Limit (dBuV/m)	Margin (dB)	Remark
5112.000	56.09	4.97	61.06	74.00	-12.94	peak
5266.500	103.60	5.35	108.95	-	-	peak
5354.100	60.16	5.56	65.72	74.00	-8.28	peak

Test Mode	IEEE 802.11n HT40 / 5270MHz	Temperature	24(°C)/ 33%RH
Test Item	Band Edge	Test Date	November 28, 2017
Polarize	Vertical	Test Engineer	Jerry Chuang
Detector	Average	Test Voltage	120Vac / 60Hz

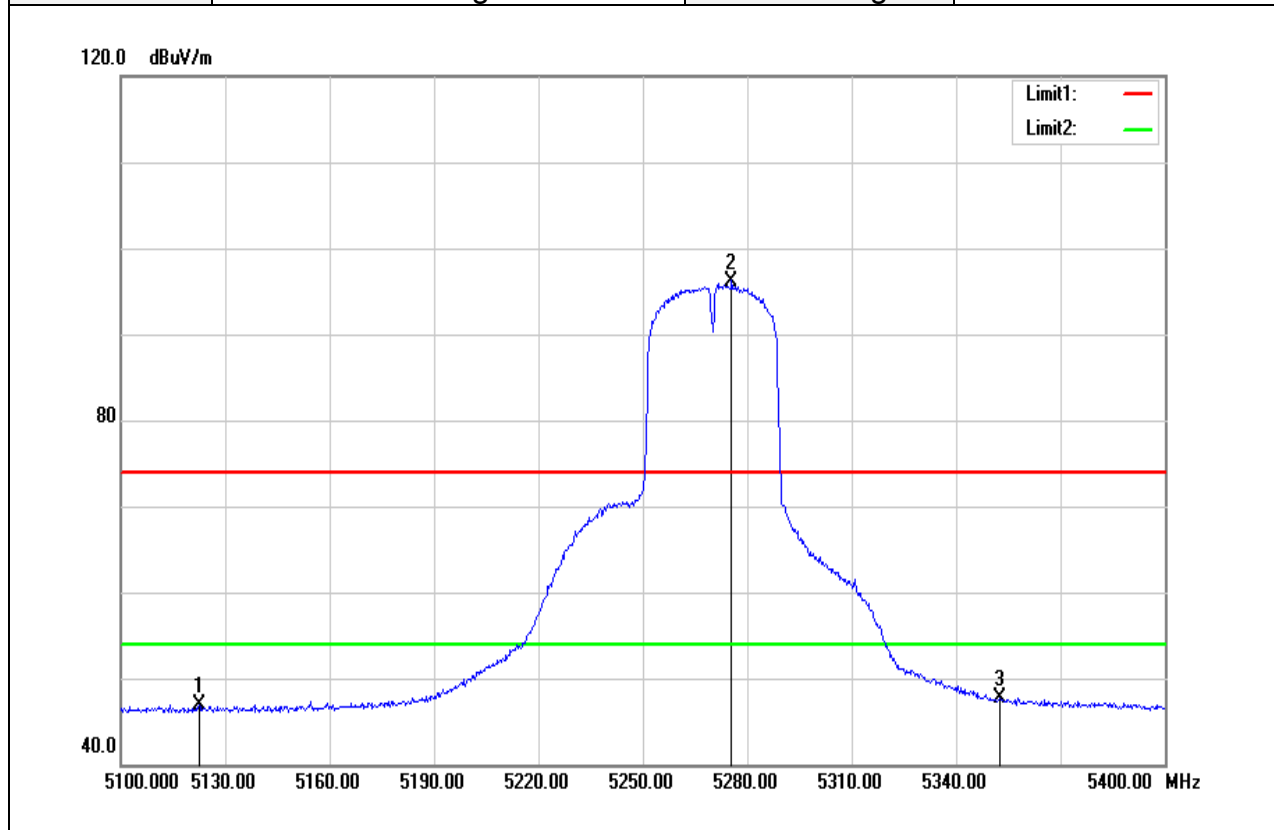

Frequency (MHz)	Reading (dBuV)	Correct Factor (dB/m)	Result (dBuV/m)	Limit (dBuV/m)	Margin (dB)	Remark
5122.500	41.93	4.99	46.92	54.00	-7.08	AVG
5275.500	90.82	5.38	96.20	-	-	AVG
5352.600	42.12	5.56	47.68	54.00	-6.32	AVG

Test Mode	IEEE 802.11n HT40 / 5310MHz	Temp/Hum	24(°C)/ 33%RH
Test Item	Band Edge	Test Date	November 28, 2017
Polarize	Vertical	Test Engineer	Jerry Chuang
Detector	Peak	Test Voltage	120Vac / 60Hz

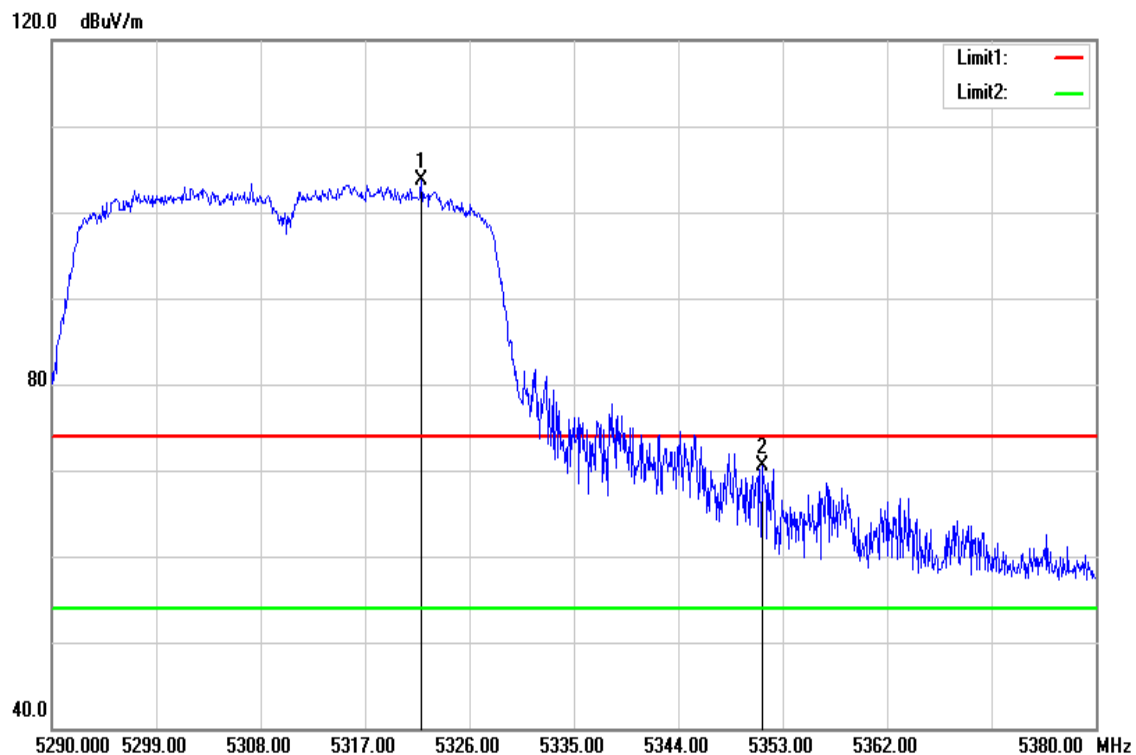

Frequency (MHz)	Reading (dBuV)	Correct Factor (dB/m)	Result (dBuV/m)	Limit (dBuV/m)	Margin (dB)	Remark
5321.860	98.28	5.48	103.76	-	-	peak
5351.200	64.91	5.56	70.47	74.00	-3.53	peak

Test Mode	IEEE 802.11n HT40 / 5310MHz	Temperature	24(°C)/ 33%RH
Test Item	Band Edge	Test Date	November 28, 2017
Polarize	Vertical	Test Engineer	Jerry Chuang
Detector	Average	Test Voltage	120Vac / 60Hz

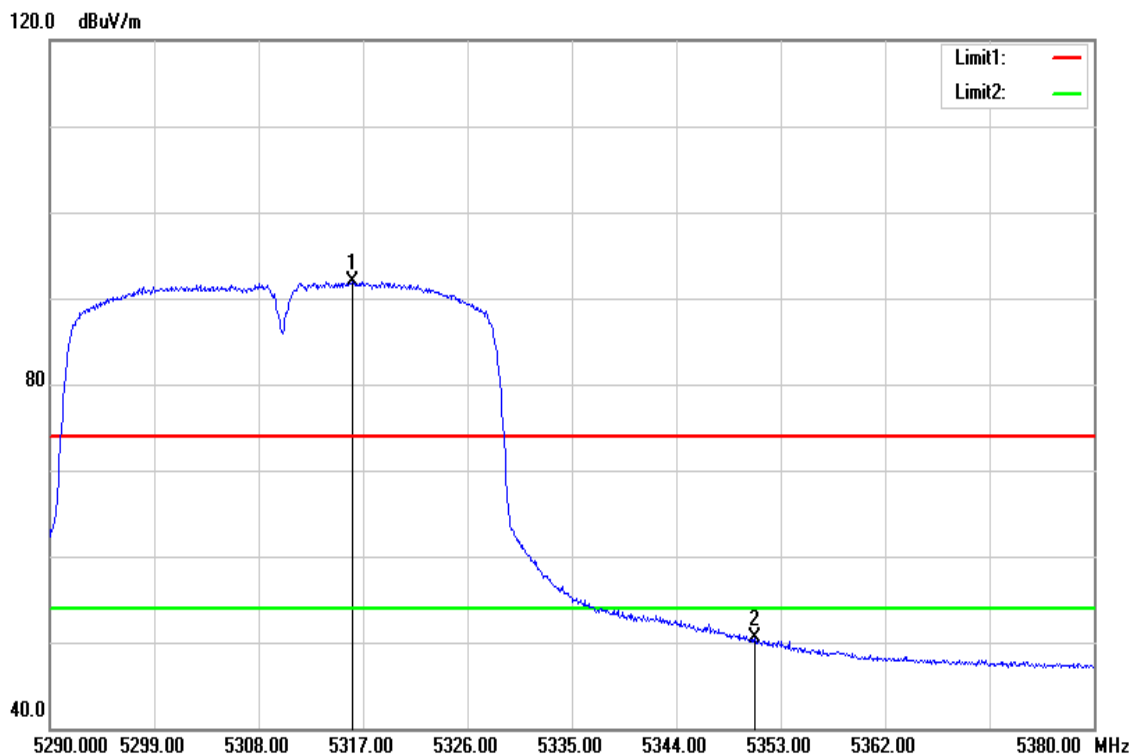

Frequency (MHz)	Reading (dBuV)	Correct Factor (dB/m)	Result (dBuV/m)	Limit (dBuV/m)	Margin (dB)	Remark
5316.100	86.46	5.48	91.94	-	-	AVG
5350.750	44.85	5.56	50.41	54.00	-3.59	AVG

Test Mode	IEEE 802.11ac VHT80 / 5290MHz	Temp/Hum	24(°C)/ 33%RH
Test Item	Band Edge	Test Date	November 28, 2017
Polarize	Vertical	Test Engineer	Jerry Chuang
Detector	Peak	Test Voltage	120Vac / 60Hz

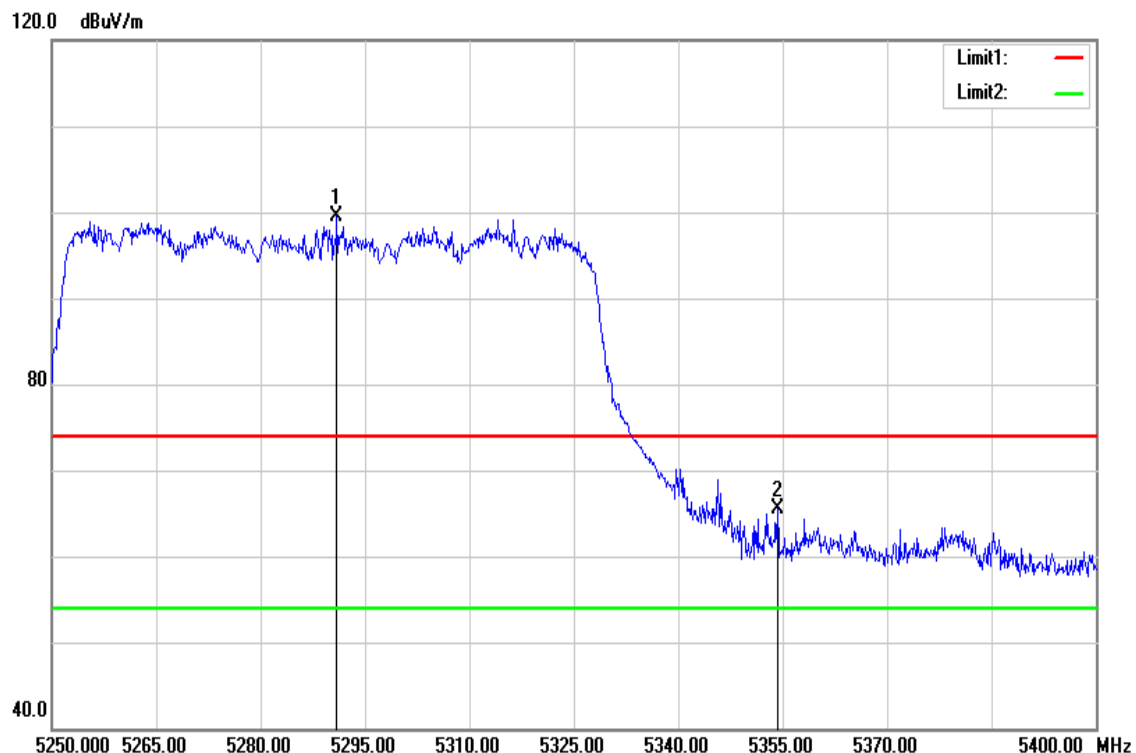

Frequency (MHz)	Reading (dBuV)	Correct Factor (dB/m)	Result (dBuV/m)	Limit (dBuV/m)	Margin (dB)	Remark
5290.950	94.08	5.41	99.49	-	-	peak
5354.250	59.97	5.56	65.53	74.00	-8.47	peak

Test Mode	IEEE 802.11ac VHT80 / 5290MHz	Temperature	24(°C)/ 33%RH
Test Item	Band Edge	Test Date	November 28, 2017
Polarize	Vertical	Test Engineer	Jerry Chuang
Detector	Average	Test Voltage	120Vac / 60Hz

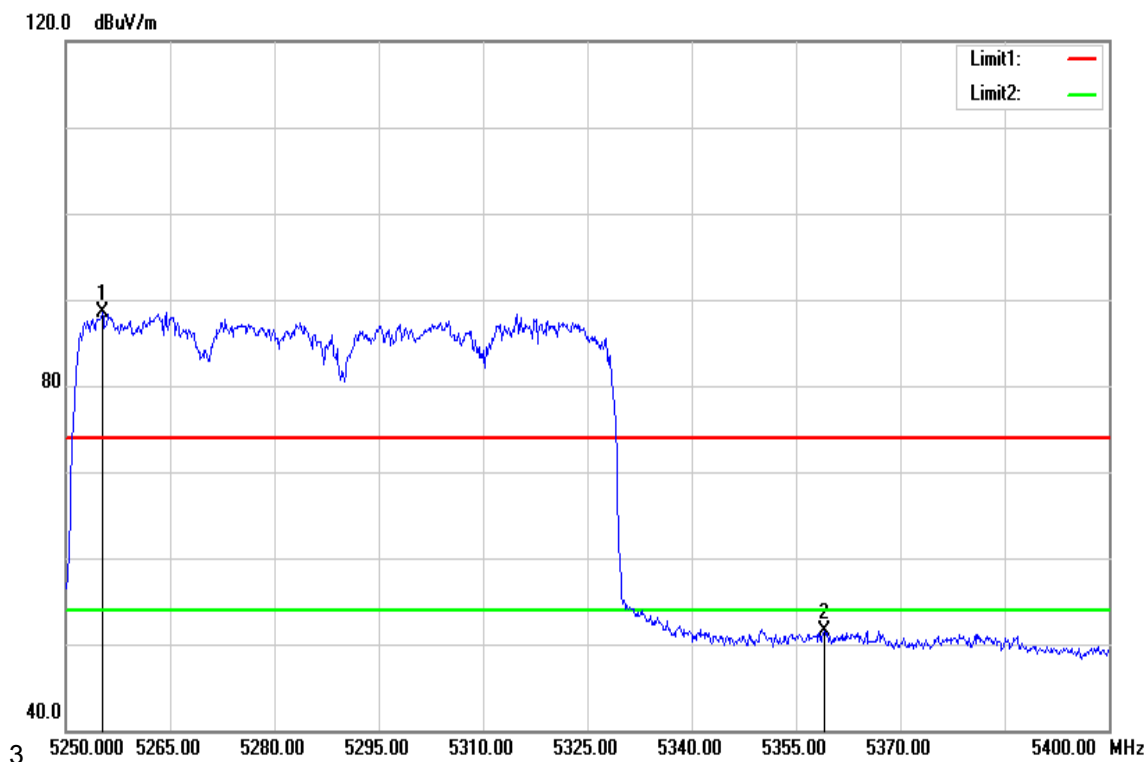

Frequency (MHz)	Reading (dBuV)	Correct Factor (dB/m)	Result (dBuV/m)	Limit (dBuV/m)	Margin (dB)	Remark
5255.250	83.14	5.32	88.46	-	-	AVG
5359.050	45.90	5.59	51.49	54.00	-2.51	AVG

Band Edge Test Data for UNII-2c

Test Mode	IEEE 802.11a / 5500MHz	Temp/Hum	24(°C)/ 33%RH
Test Item	Band Edge	Test Date	November 28, 2017
Polarize	Vertical	Test Engineer	Jerry Chuang
Detector	Peak	Test Voltage	120Vac / 60Hz

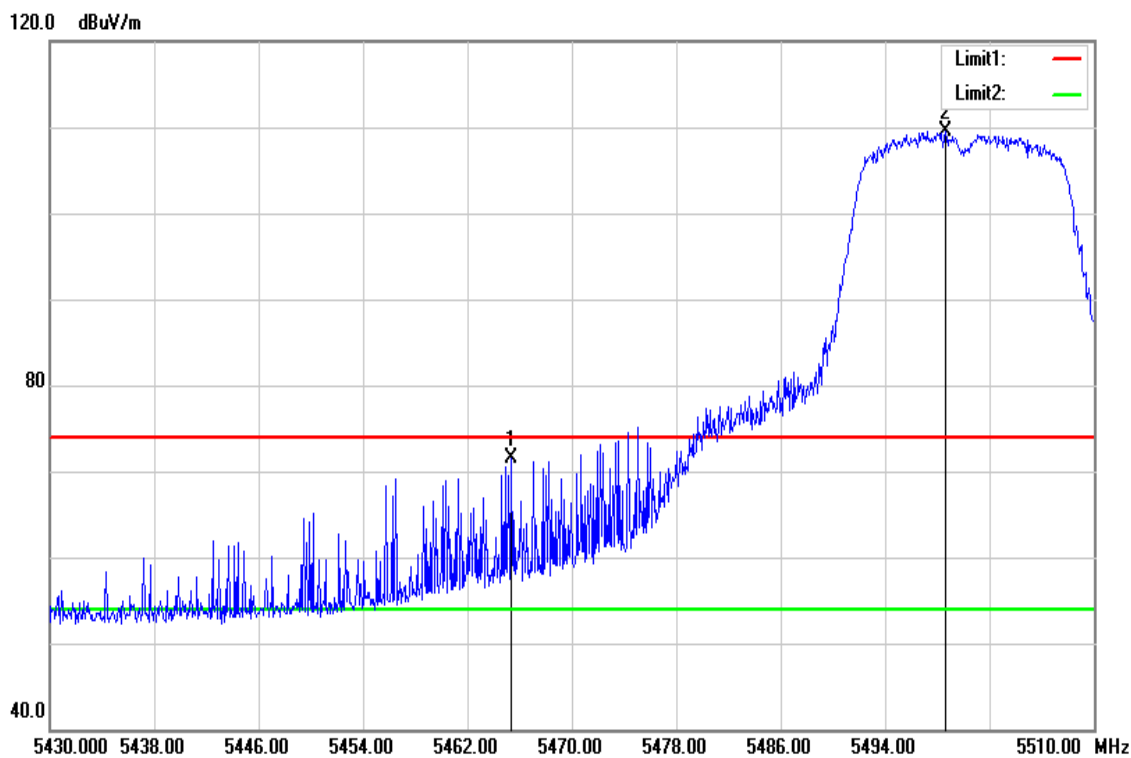

Frequency (MHz)	Reading (dBuV)	Correct Factor (dB/m)	Result (dBuV/m)	Limit (dBuV/m)	Margin (dB)	Remark
5465.360	65.57	5.85	71.42	74.00	-2.58	peak
5498.640	103.50	5.93	109.43	-	-	peak

Test Mode	IEEE 802.11a / 5500MHz	Temperature	24(°C)/ 33%RH
Test Item	Band Edge	Test Date	November 28, 2017
Polarize	Vertical	Test Engineer	Jerry Chuang
Detector	Average	Test Voltage	120Vac / 60Hz

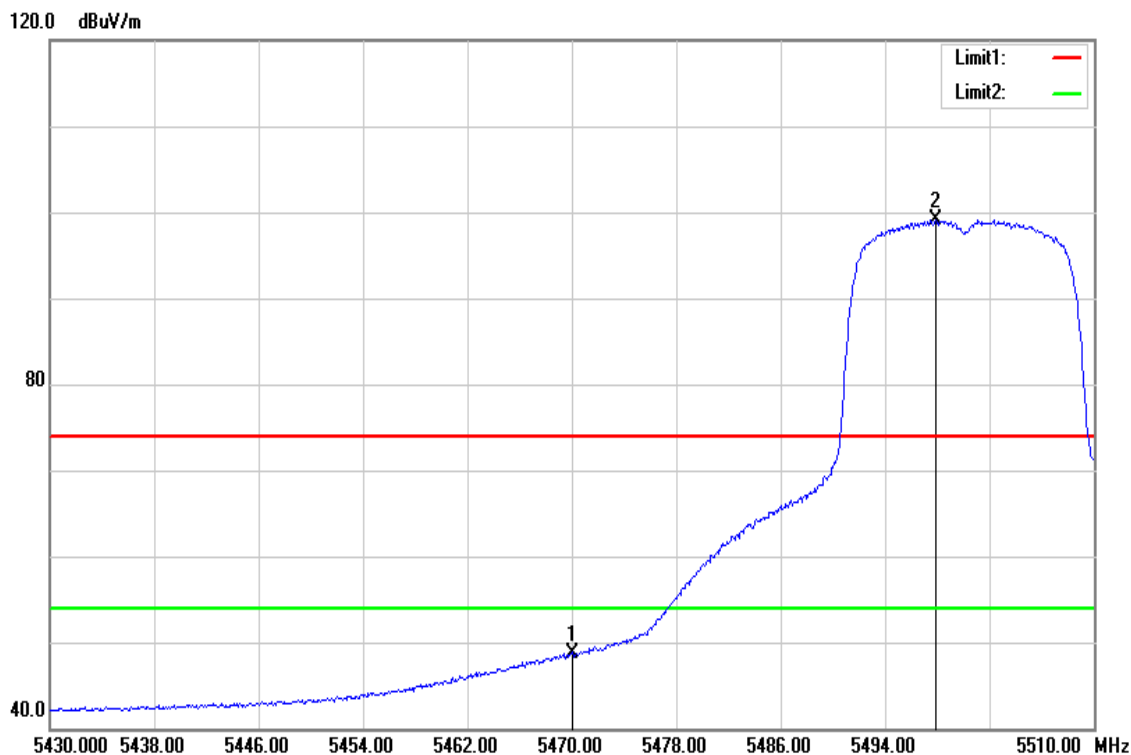

Frequency (MHz)	Reading (dBuV)	Correct Factor (dB/m)	Result (dBuV/m)	Limit (dBuV/m)	Margin (dB)	Remark
5470.000	42.79	5.85	48.64	54.00	-5.36	AVG
5497.840	93.19	5.93	99.12	-	-	AVG

Test Mode	IEEE 802.11a / 5700 MHz	Temp/Hum	24(°C)/ 33%RH
Test Item	Band Edge	Test Date	November 28, 2017
Polarize	Vertical	Test Engineer	Jerry Chuang
Detector	Peak	Test Voltage	120Vac / 60Hz

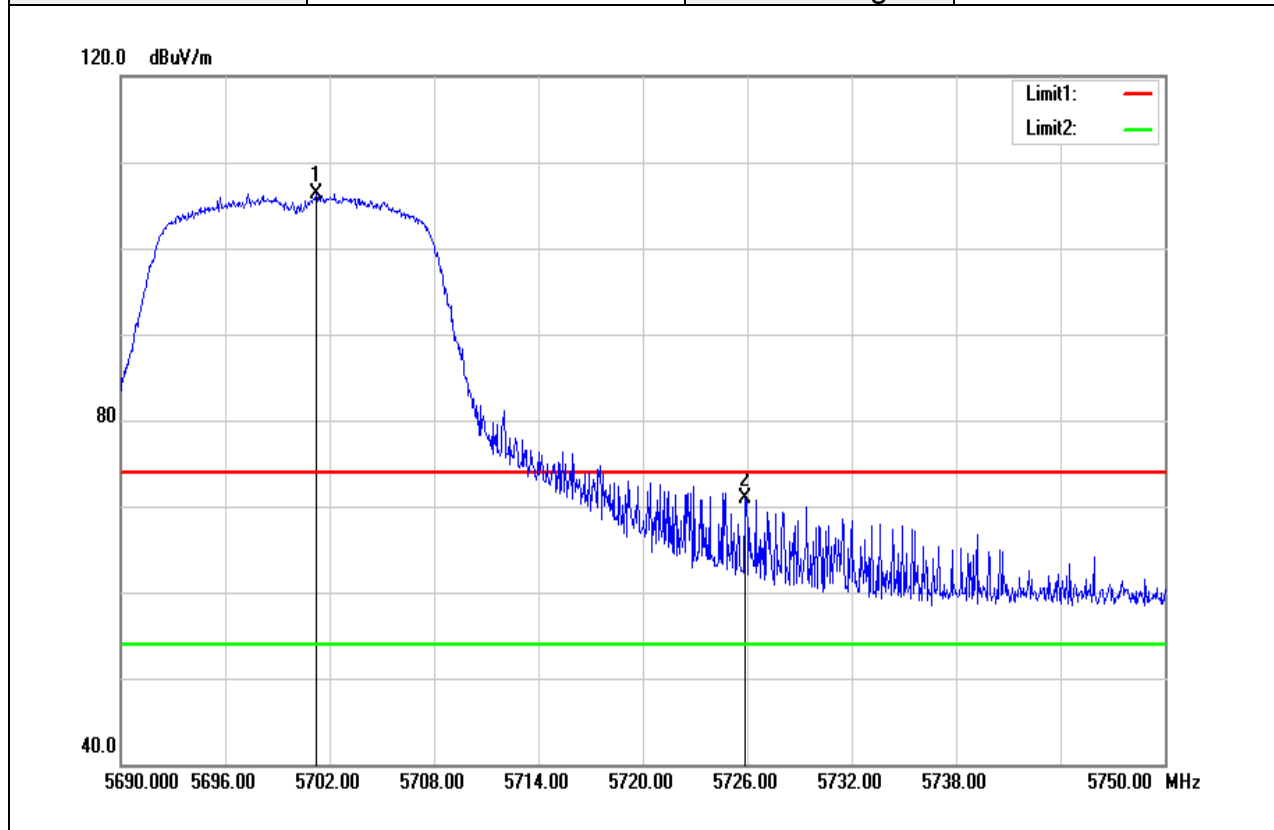

Frequency (MHz)	Reading (dBuV)	Correct Factor (dB/m)	Result (dBuV/m)	Limit (dBuV/m)	Margin (dB)	Remark
5701.220	99.87	6.45	106.32	74.00	32.32	peak
5725.880	64.30	6.52	70.82	74.00	-3.18	peak

Test Mode	IEEE 802.11a / 5700 MHz	Temperature	24(°C)/ 33%RH
Test Item	Band Edge	Test Date	November 28, 2017
Polarize	Vertical	Test Engineer	Jerry Chuang
Detector	Average	Test Voltage	120Vac / 60Hz

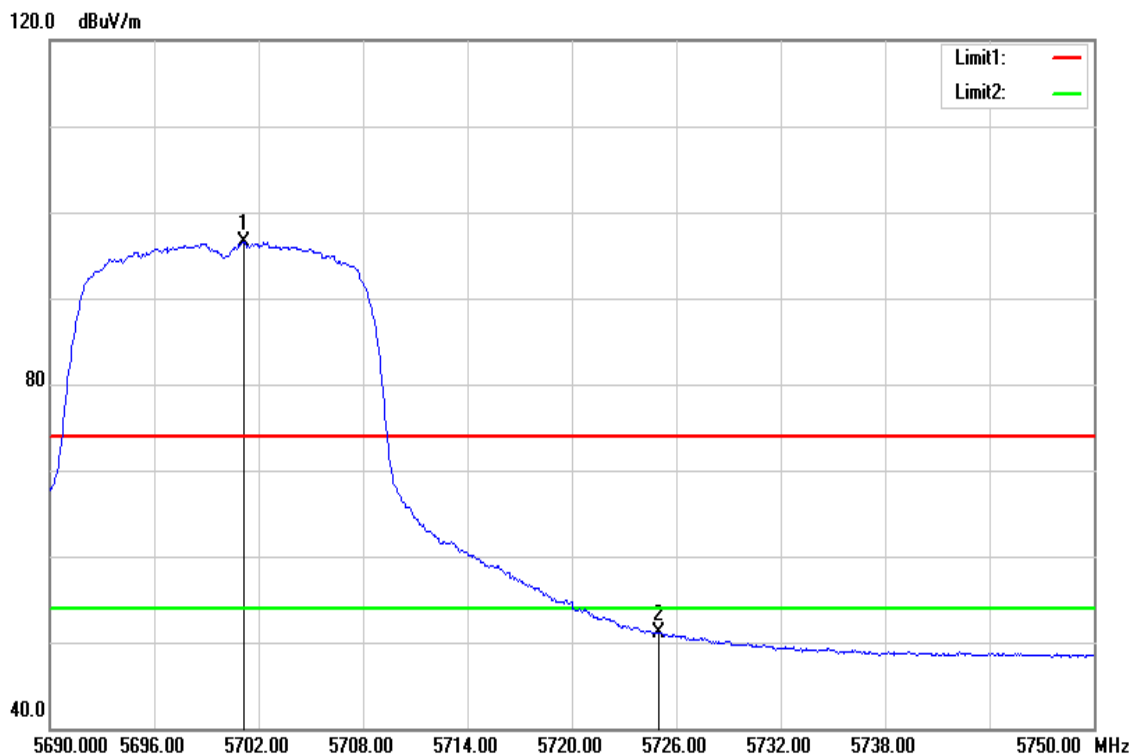

Frequency (MHz)	Reading (dBuV)	Correct Factor (dB/m)	Result (dBuV/m)	Limit (dBuV/m)	Margin (dB)	Remark
5701.160	90.11	6.45	96.56	-	-	AVG
5725.000	44.58	6.52	51.10	54.00	-2.90	AVG

Test Mode	IEEE 802.11a / 5720 MHz	Temp/Hum	24(°C)/ 33%RH
Test Item	Band Edge	Test Date	November 28, 2017
Polarize	Vertical	Test Engineer	Jerry Chuang
Detector	Peak	Test Voltage	120Vac / 60Hz

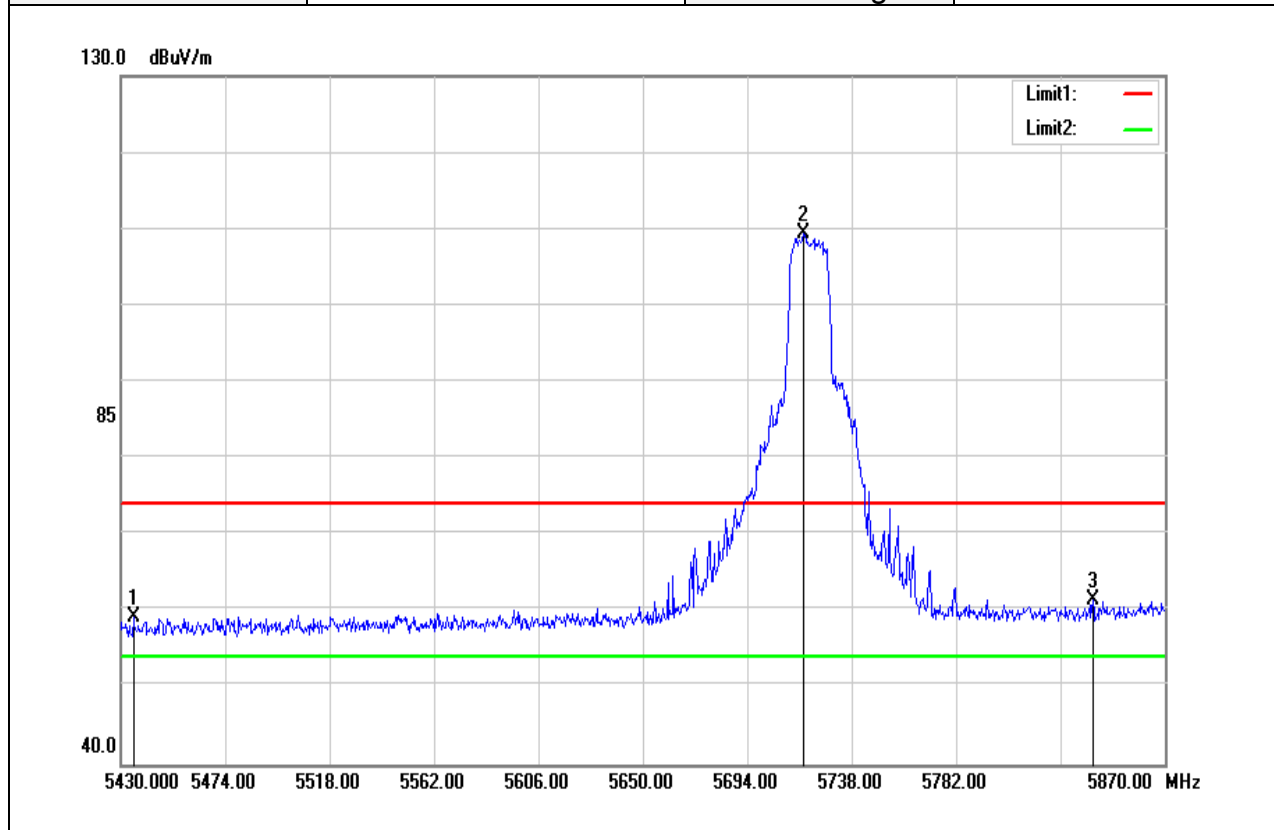

Frequency (MHz)	Reading (dBuV)	Correct Factor (dB/m)	Result (dBuV/m)	Limit (dBuV/m)	Margin (dB)	Remark
5435.280	53.54	5.77	59.31	74.00	-14.69	peak
5717.760	102.88	6.50	109.38	-	-	peak
5839.640	54.58	6.82	61.40	74.00	-12.60	peak

Test Mode	IEEE 802.11a / 5700 MHz	Temperature	24(°C)/ 33%RH
Test Item	Band Edge	Test Date	November 28, 2017
Polarize	Vertical	Test Engineer	Jerry Chuang
Detector	Average	Test Voltage	120Vac / 60Hz

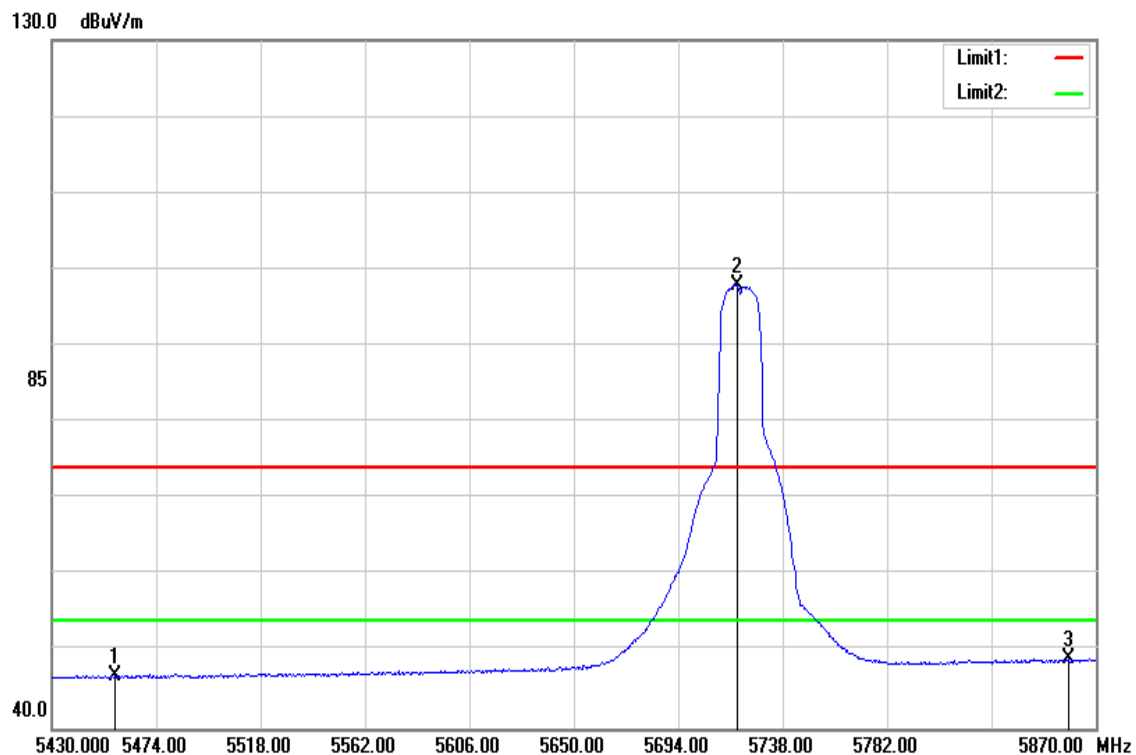

Frequency (MHz)	Reading (dBuV)	Correct Factor (dB/m)	Result (dBuV/m)	Limit (dBuV/m)	Margin (dB)	Remark
5456.840	41.14	5.82	46.96	54.00	-7.04	AVG
5718.640	91.44	6.50	97.94	-	-	AVG
5858.560	42.20	6.87	49.07	54.00	-4.93	AVG

Test Mode	IEEE 802.11n HT20 / 5500MHz	Temp/Hum	24(°C)/ 33%RH
Test Item	Band Edge	Test Date	November 28, 2017
Polarize	Vertical	Test Engineer	Jerry Chuang
Detector	Peak	Test Voltage	120Vac / 60Hz

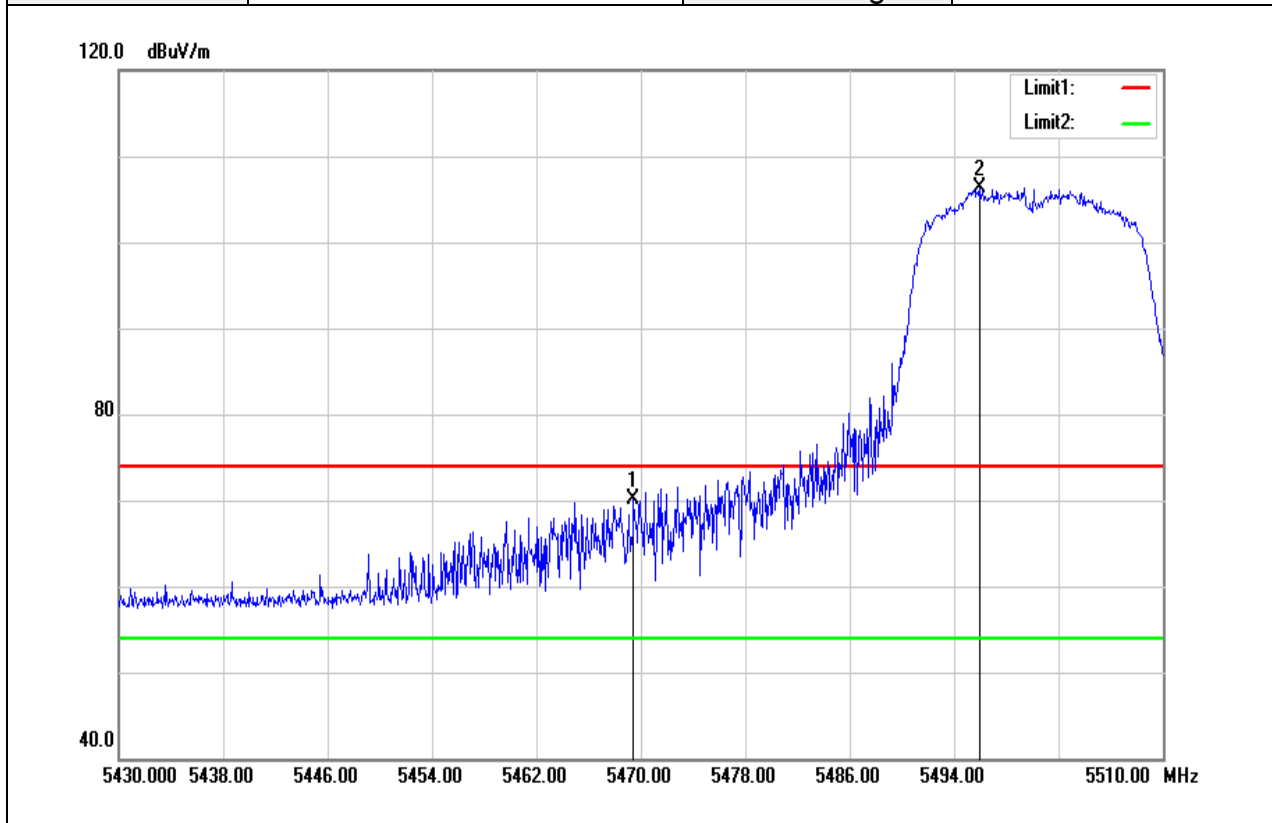

Frequency (MHz)	Reading (dBuV)	Correct Factor (dB/m)	Result (dBuV/m)	Limit (dBuV/m)	Margin (dB)	Remark
5469.440	64.22	5.85	70.07	74.00	-3.93	peak
5496.000	100.42	5.93	106.35	-	-	peak

Test Mode	IEEE 802.11n HT20 / 5500MHz	Temperature	24(°C)/ 33%RH
Test Item	Band Edge	Test Date	November 28, 2017
Polarize	Vertical	Test Engineer	Jerry Chuang
Detector	Average	Test Voltage	120Vac / 60Hz

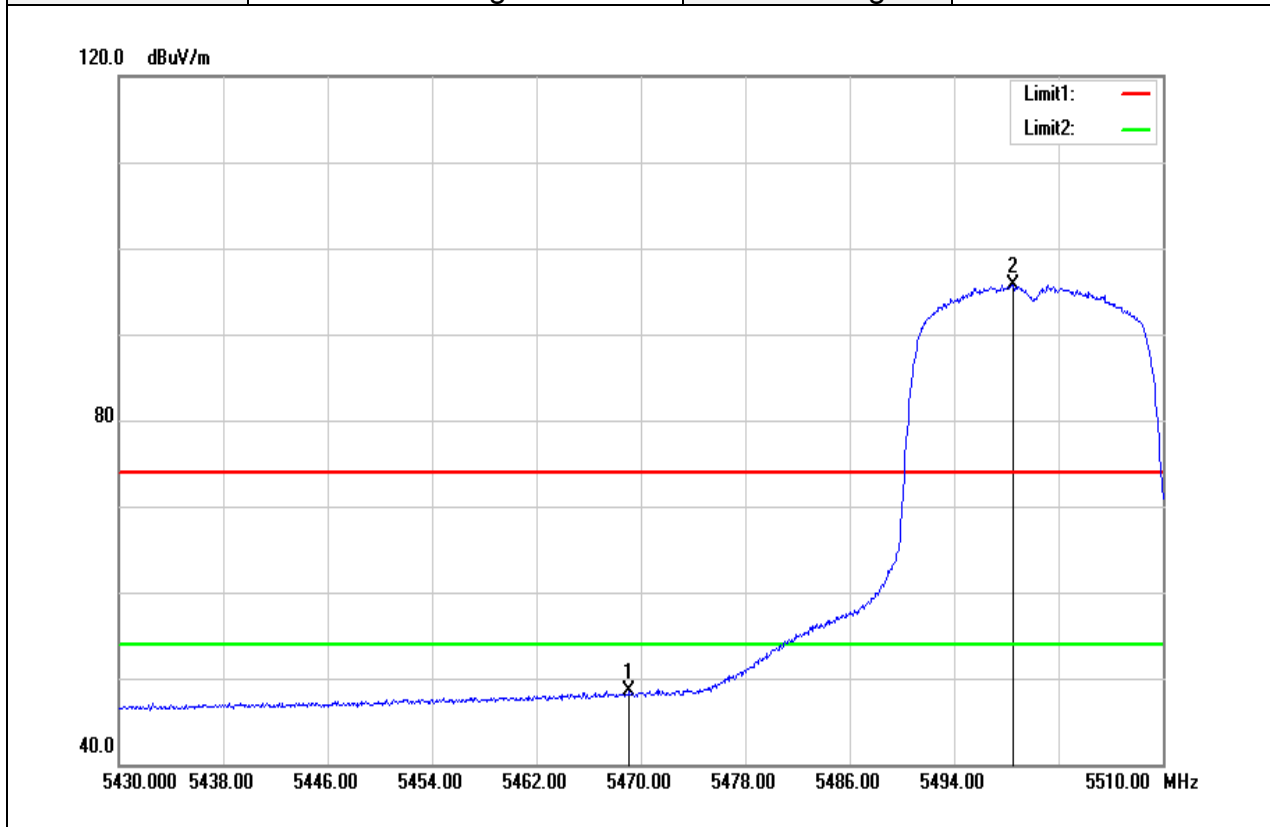

Frequency (MHz)	Reading (dBuV)	Correct Factor (dB/m)	Result (dBuV/m)	Limit (dBuV/m)	Margin (dB)	Remark
5469.120	42.65	5.85	48.50	54.00	-5.50	AVG
5498.560	89.80	5.93	95.73	-	-	AVG

Test Mode	IEEE 802.11n HT20 / 5700 MHz	Temp/Hum	24(°C)/ 33%RH
Test Item	Band Edge	Test Date	November 28, 2017
Polarize	Vertical	Test Engineer	Jerry Chuang
Detector	Peak	Test Voltage	120Vac / 60Hz

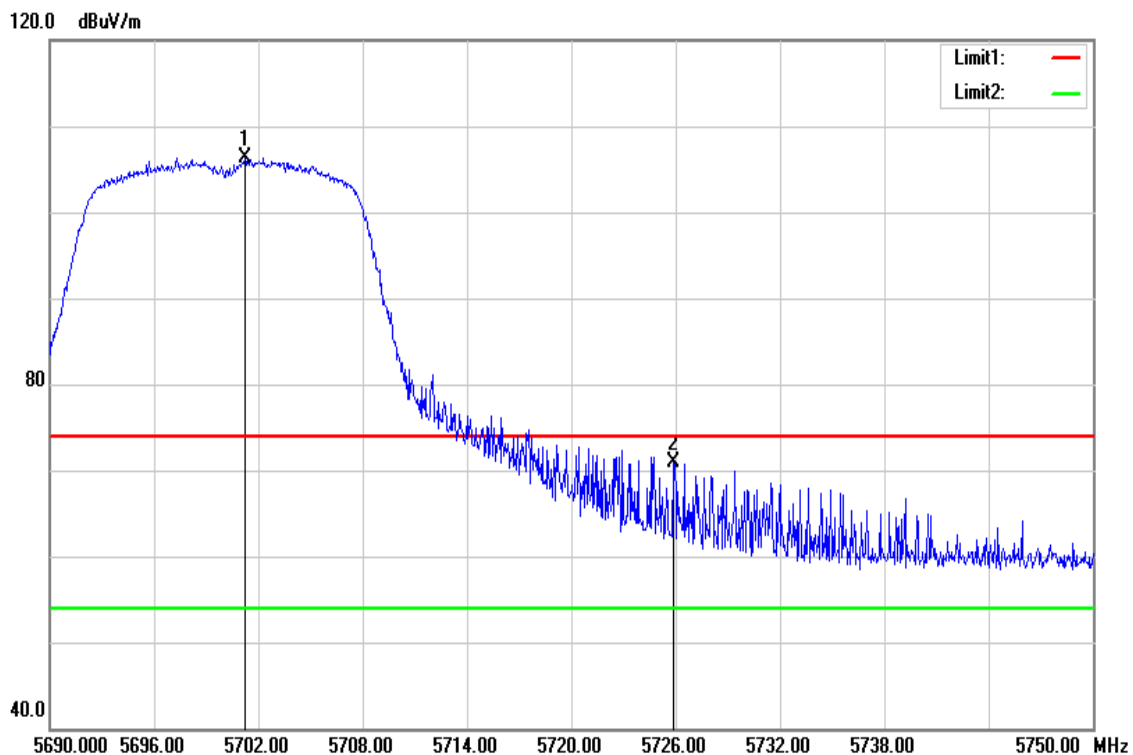

Frequency (MHz)	Reading (dBuV)	Correct Factor (dB/m)	Result (dBuV/m)	Limit (dBuV/m)	Margin (dB)	Remark
5701.220	99.87	6.45	106.32	-	-	peak
5725.880	64.30	6.52	70.82	74.00	-3.18	peak

Test Mode	IEEE 802.11n HT20 / 5700 MHz	Temperature	24(°C)/ 33%RH
Test Item	Band Edge	Test Date	November 28, 2017
Polarize	Vertical	Test Engineer	Jerry Chuang
Detector	Average	Test Voltage	120Vac / 60Hz

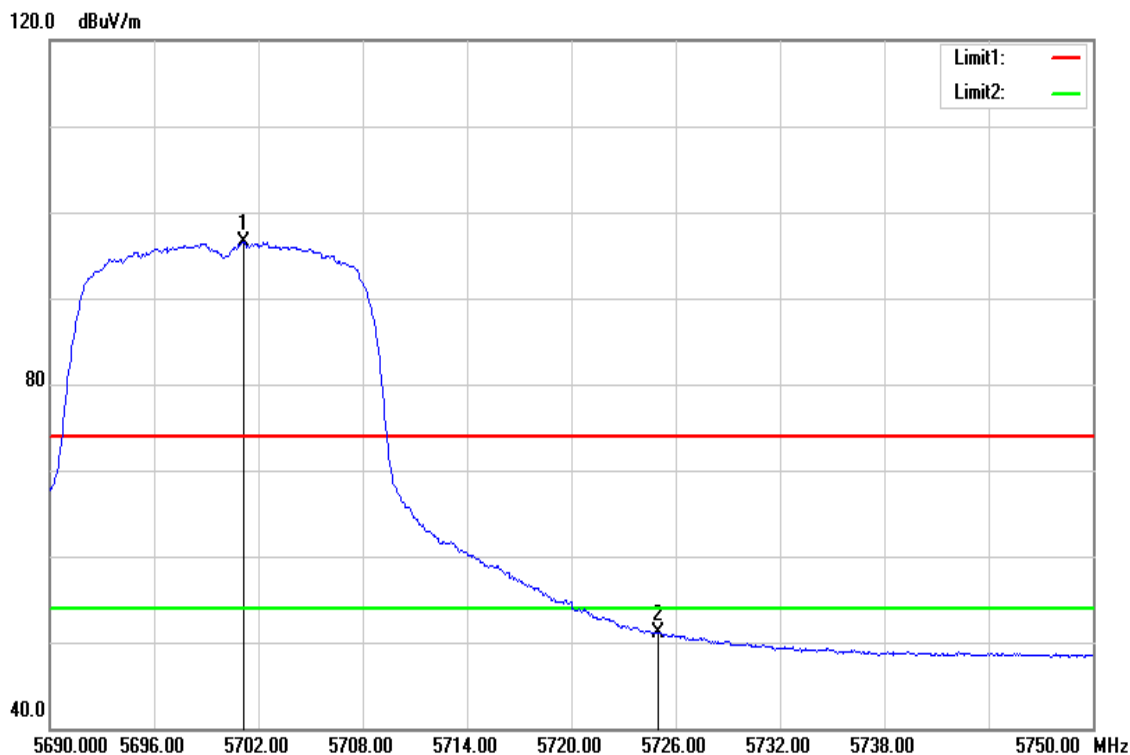

Frequency (MHz)	Reading (dBuV)	Correct Factor (dB/m)	Result (dBuV/m)	Limit (dBuV/m)	Margin (dB)	Remark
5701.160	90.11	6.45	96.56	-	-	AVG
5725.000	44.58	6.52	51.10	54.00	-2.90	AVG

Test Mode	IEEE 802.11n HT20 / 5720 MHz	Temp/Hum	24(°C)/ 33%RH
Test Item	Band Edge	Test Date	November 28, 2017
Polarize	Vertical	Test Engineer	Jerry Chuang
Detector	Peak	Test Voltage	120Vac / 60Hz

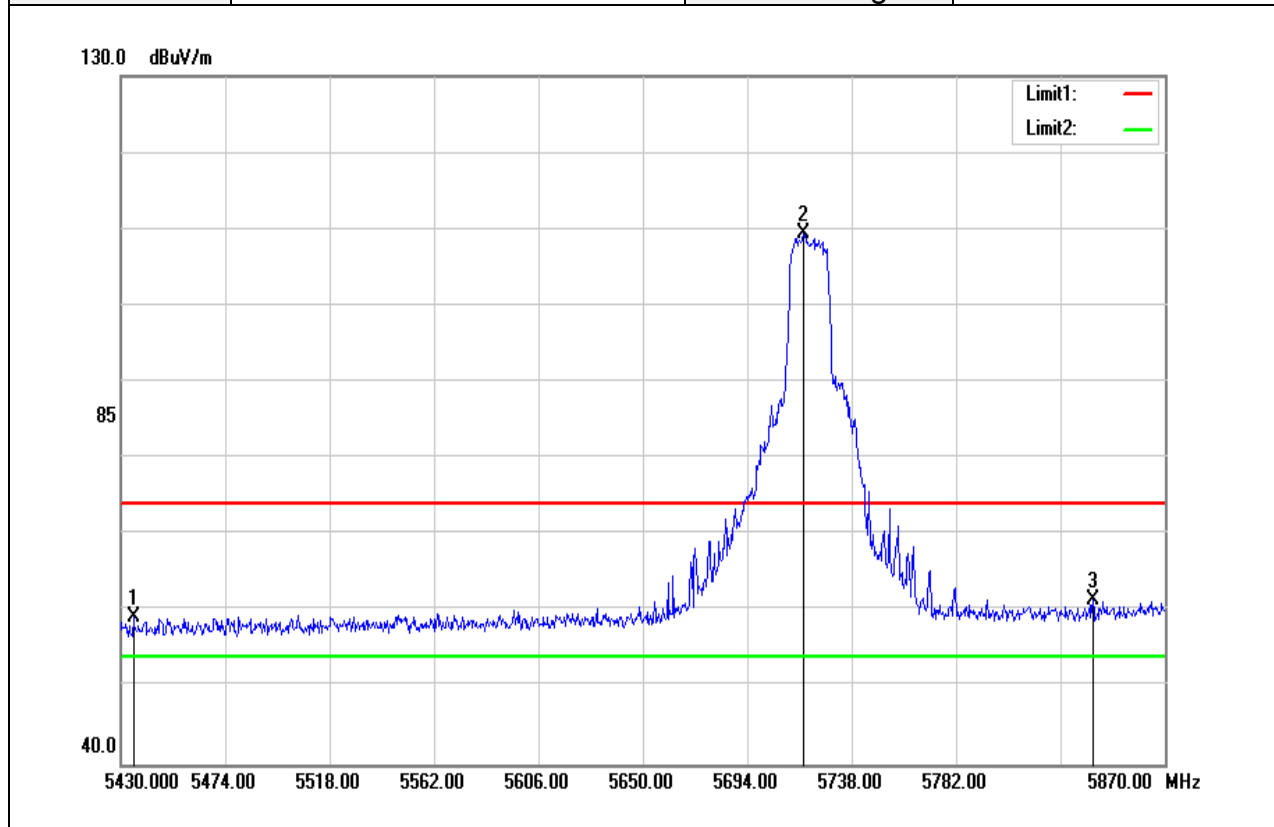

Frequency (MHz)	Reading (dBuV)	Correct Factor (dB/m)	Result (dBuV/m)	Limit (dBuV/m)	Margin (dB)	Remark
5435.280	53.54	5.77	59.31	74.00	-14.69	peak
5717.760	102.88	6.50	109.38	-	-	peak
5839.640	54.58	6.82	61.40	74.00	-12.60	peak

Test Mode	IEEE 802.11n HT20 / 5720 MHz	Temperature	24(°C)/ 33%RH
Test Item	Band Edge	Test Date	November 28, 2017
Polarize	Vertical	Test Engineer	Jerry Chuang
Detector	Average	Test Voltage	120Vac / 60Hz

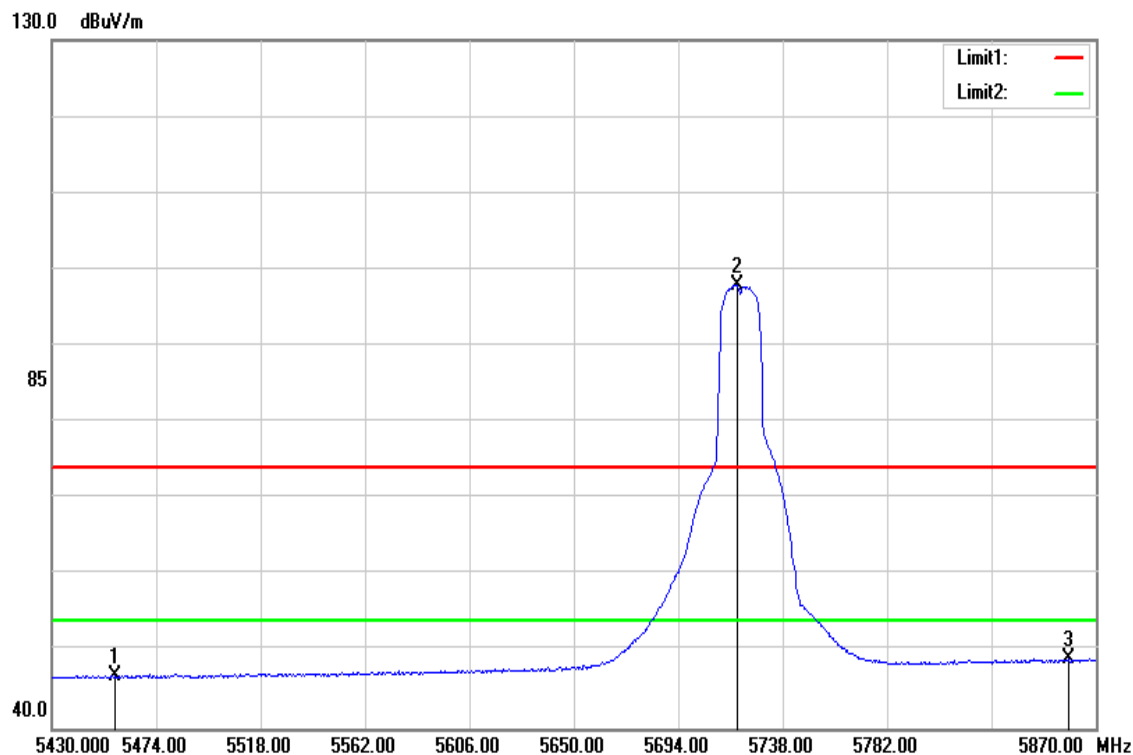

Frequency (MHz)	Reading (dBuV)	Correct Factor (dB/m)	Result (dBuV/m)	Limit (dBuV/m)	Margin (dB)	Remark
5456.840	41.14	5.82	46.96	54.00	-7.04	AVG
5718.640	91.44	6.50	97.94	-	-	AVG
5858.560	42.20	6.87	49.07	54.00	-4.93	AVG

Test Mode	IEEE 802.11n HT40 / 5510 MHz	Temp/Hum	24(°C)/ 33%RH
Test Item	Band Edge	Test Date	November 28, 2017
Polarize	Vertical	Test Engineer	Jerry Chuang
Detector	Peak	Test Voltage	120Vac / 60Hz

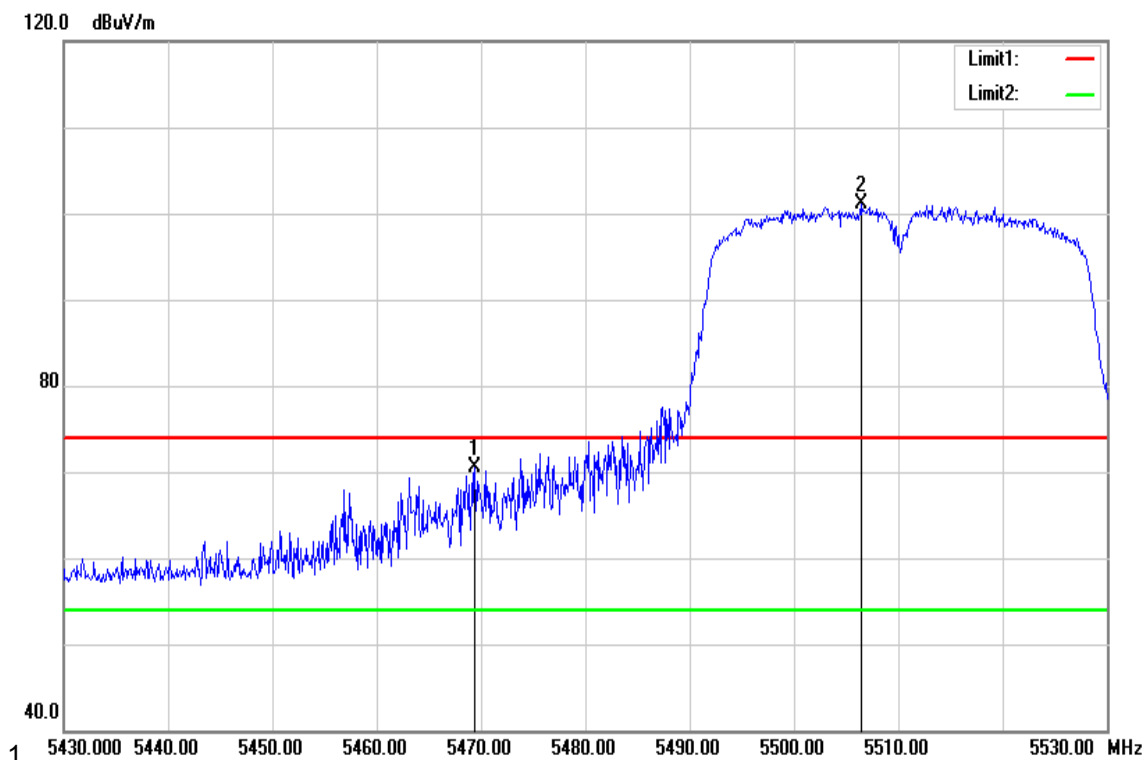

Frequency (MHz)	Reading (dBuV)	Correct Factor (dB/m)	Result (dBuV/m)	Limit (dBuV/m)	Margin (dB)	Remark
5469.400	64.57	5.85	70.42	74.00	-3.58	peak
5506.400	95.16	5.95	101.11	-	-	peak

Test Mode	IEEE 802.11n HT40 / 5510 MHz	Temperature	24(°C)/ 33%RH
Test Item	Band Edge	Test Date	November 28, 2017
Polarize	Vertical	Test Engineer	Jerry Chuang
Detector	Average	Test Voltage	120Vac / 60Hz

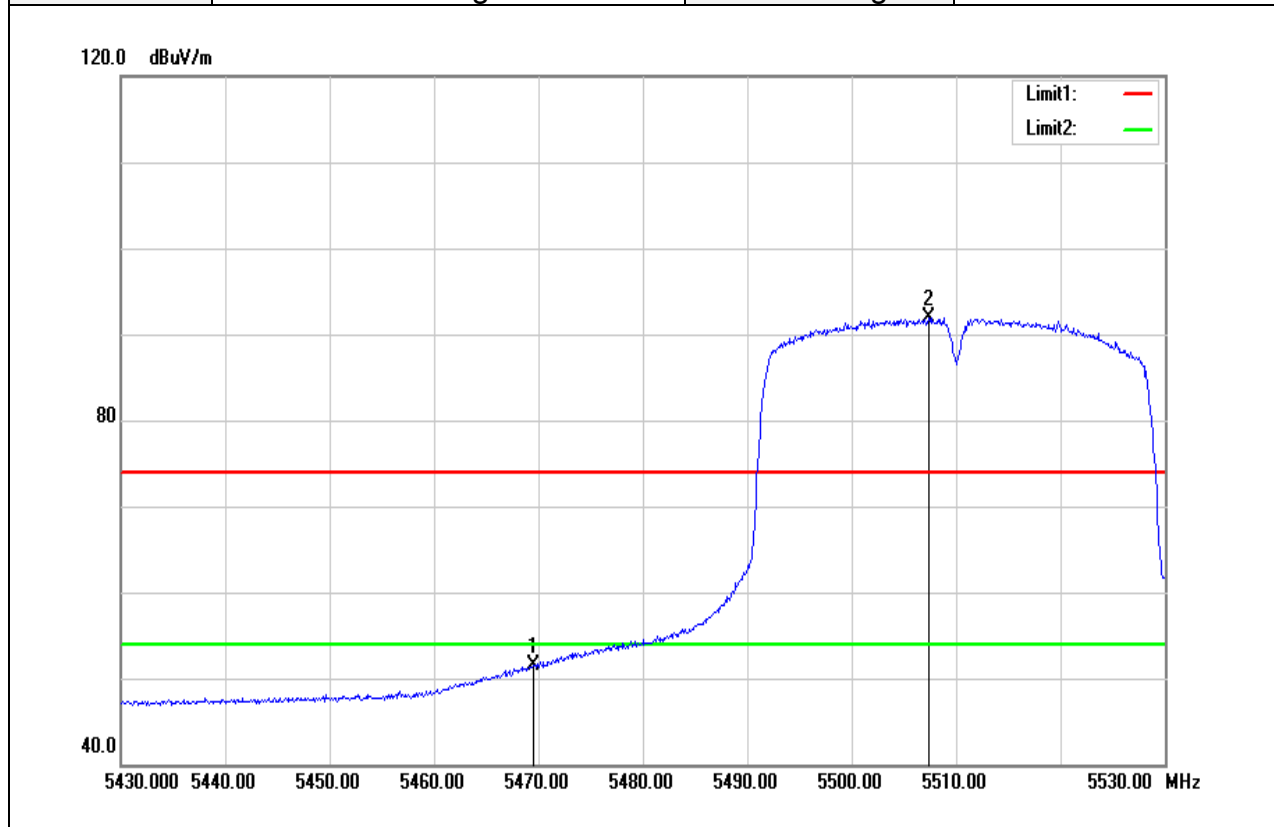

Frequency (MHz)	Reading (dBuV)	Correct Factor (dB/m)	Result (dBuV/m)	Limit (dBuV/m)	Margin (dB)	Remark
5469.500	45.73	5.85	51.58	54.00	-2.42	AVG
5507.400	85.94	5.95	91.89	-	-	AVG

Test Mode	IEEE 802.11n HT40 / 5670 MHz	Temp/Hum	24(°C)/ 33%RH
Test Item	Band Edge	Test Date	November 28, 2017
Polarize	Vertical	Test Engineer	Jerry Chuang
Detector	Peak	Test Voltage	120Vac / 60Hz

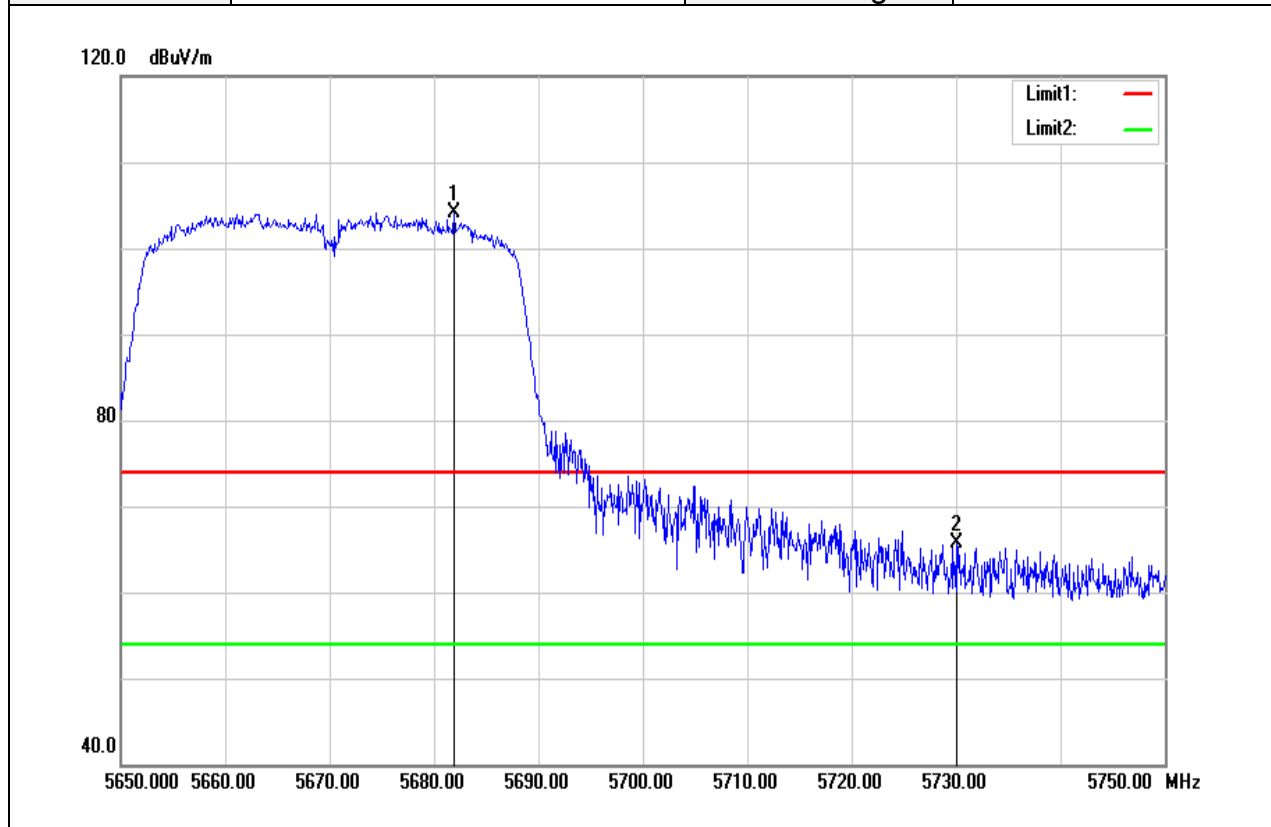

Frequency (MHz)	Reading (dBuV)	Correct Factor (dB/m)	Result (dBuV/m)	Limit (dBuV/m)	Margin (dB)	Remark
5681.900	97.68	6.40	104.08	-	-	peak
5730.000	59.12	6.54	65.66	74.00	-8.34	peak

Test Mode	IEEE 802.11n HT40 / 5670 MHz	Temperature	24(°C)/ 33%RH
Test Item	Band Edge	Test Date	November 28, 2017
Polarize	Vertical	Test Engineer	Jerry Chuang
Detector	Average	Test Voltage	120Vac / 60Hz

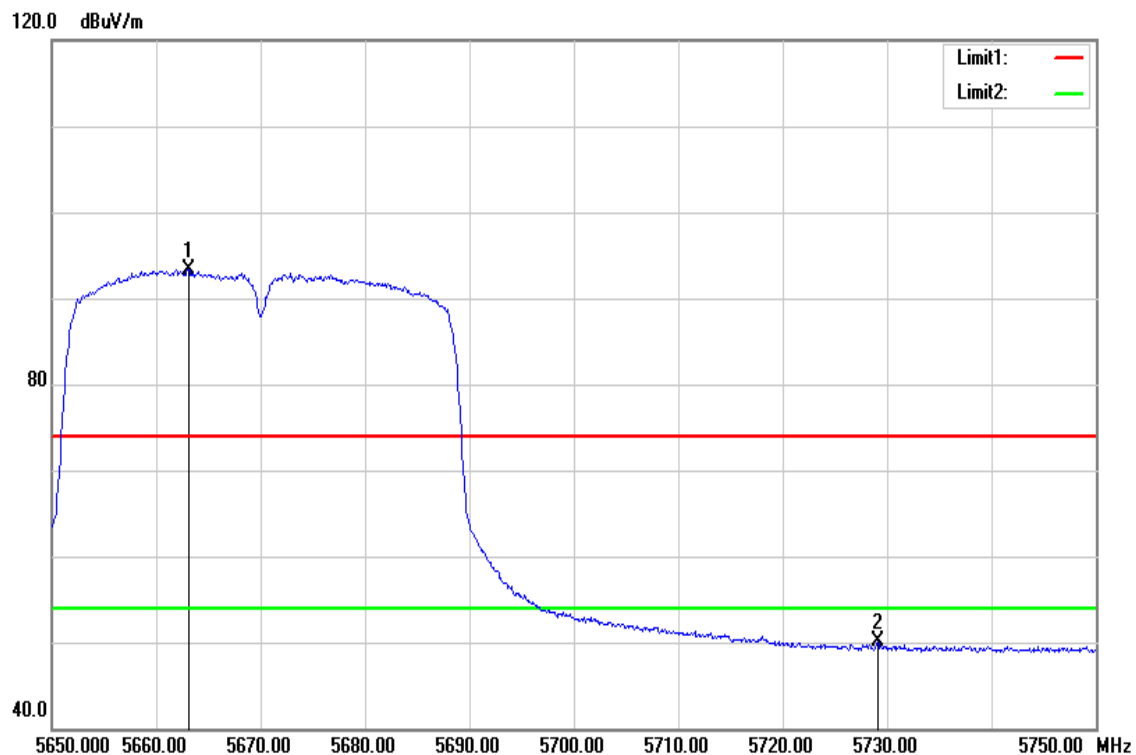

Frequency (MHz)	Reading (dBuV)	Correct Factor (dB/m)	Result (dBuV/m)	Limit (dBuV/m)	Margin (dB)	Remark
5663.100	86.94	6.37	93.31	-	-	AVG
5729.100	43.52	6.53	50.05	54.00	-3.95	AVG

Test Mode	IEEE 802.11n HT40 / 5710 MHz	Temp/Hum	24(°C)/ 33%RH
Test Item	Band Edge	Test Date	November 28, 2017
Polarize	Vertical	Test Engineer	Jerry Chuang
Detector	Peak	Test Voltage	120Vac / 60Hz

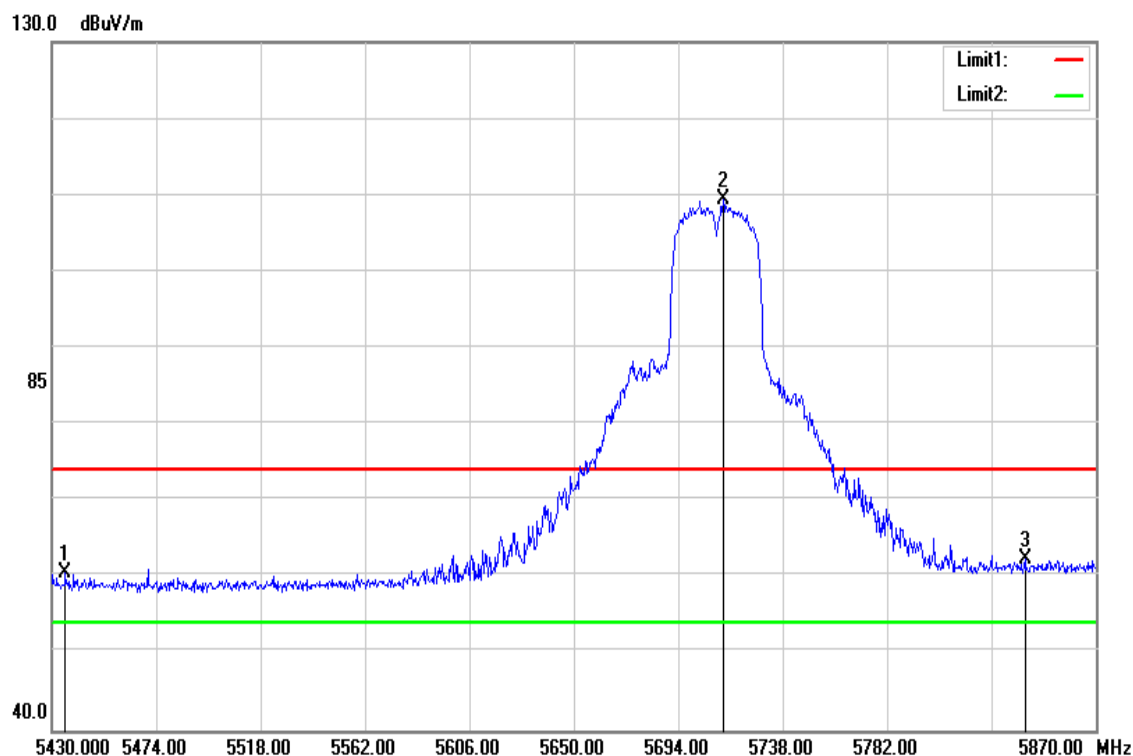

Frequency (MHz)	Reading (dBuV)	Correct Factor (dB/m)	Result (dBuV/m)	Limit (dBuV/m)	Margin (dB)	Remark
5435.720	55.07	5.55	60.62	74.00	-13.38	peak
5712.920	103.26	6.16	109.42	-	-	peak
5840.080	55.79	6.70	62.49	74.00	-11.51	peak

Test Mode	IEEE 802.11n HT40 / 5710 MHz	Temperature	24(°C)/ 33%RH
Test Item	Band Edge	Test Date	November 28, 2017
Polarize	Vertical	Test Engineer	Jerry Chuang
Detector	Average	Test Voltage	120Vac / 60Hz

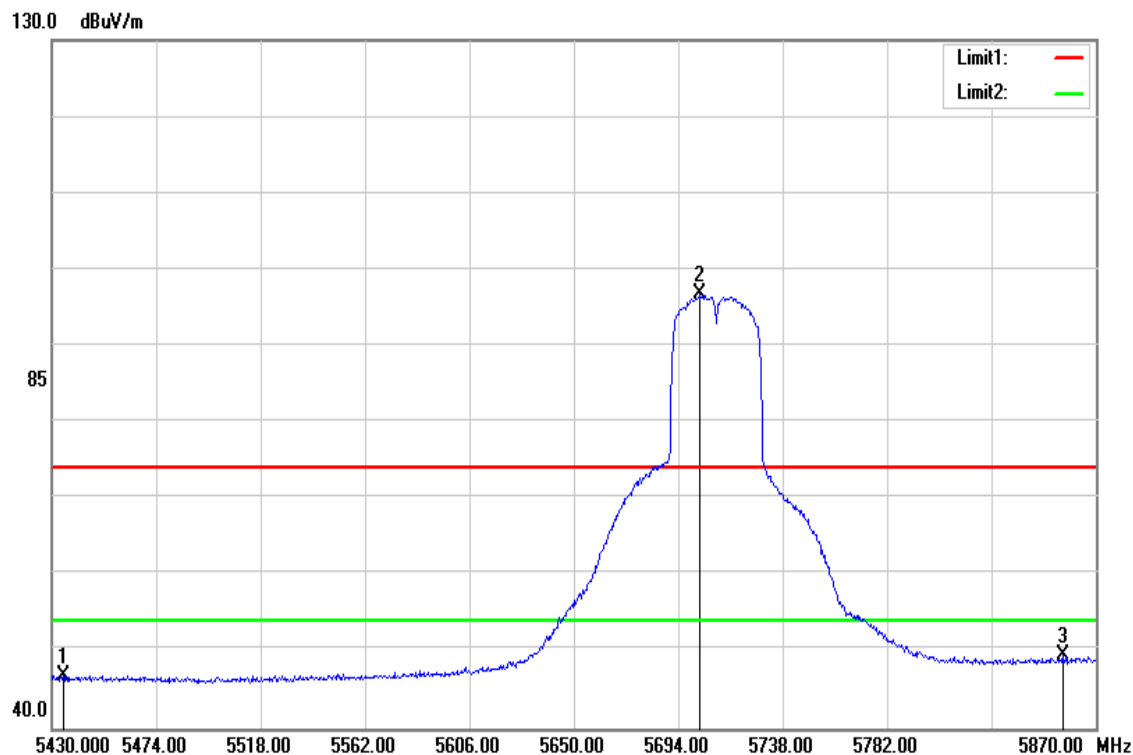

Frequency (MHz)	Reading (dBuV)	Correct Factor (dB/m)	Result (dBuV/m)	Limit (dBuV/m)	Margin (dB)	Remark
5434.840	41.34	5.56	46.90	54.00	-7.10	AVG
5703.240	90.61	6.12	96.73	-	-	AVG
5855.920	42.89	6.77	49.66	54.00	-4.34	AVG

Test Mode	IEEE 802.11ac VHT80 / 5530 MHz	Temp/Hum	24(°C)/ 33%RH
Test Item	Band Edge	Test Date	Mar 24, 2017
Polarize	Vertical	Test Engineer	Jerry Chuang
Detector	Peak	Test Voltage	120Vac / 60Hz

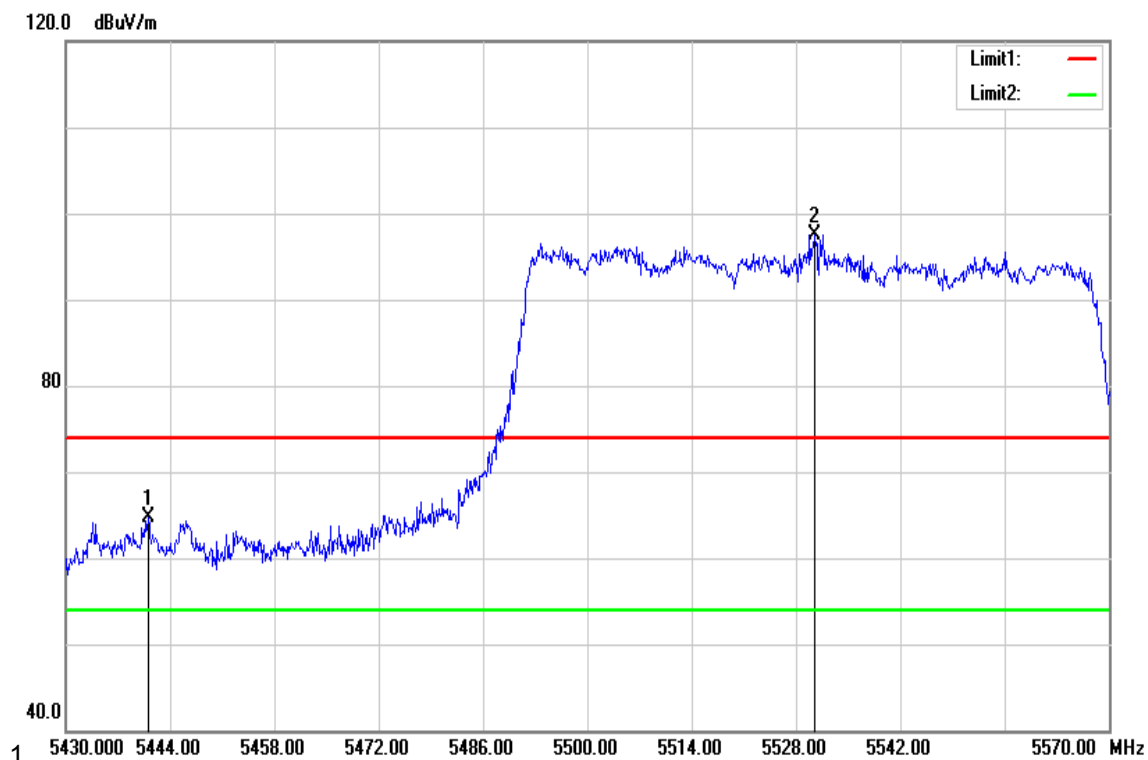

Frequency (MHz)	Reading (dBuV)	Correct Factor (dB/m)	Result (dBuV/m)	Limit (dBuV/m)	Margin (dB)	Remark
5441.060	58.95	5.78	64.73	74.00	-9.27	peak
5530.520	91.52	6.01	97.53	-	-	peak

Test Mode	IEEE 802.11ac VHT80 / 5530 MHz	Temperature	24(°C)/ 33%RH
Test Item	Band Edge	Test Date	Mar 24, 2017
Polarize	Vertical	Test Engineer	Jerry Chuang
Detector	Average	Test Voltage	120Vac / 60Hz

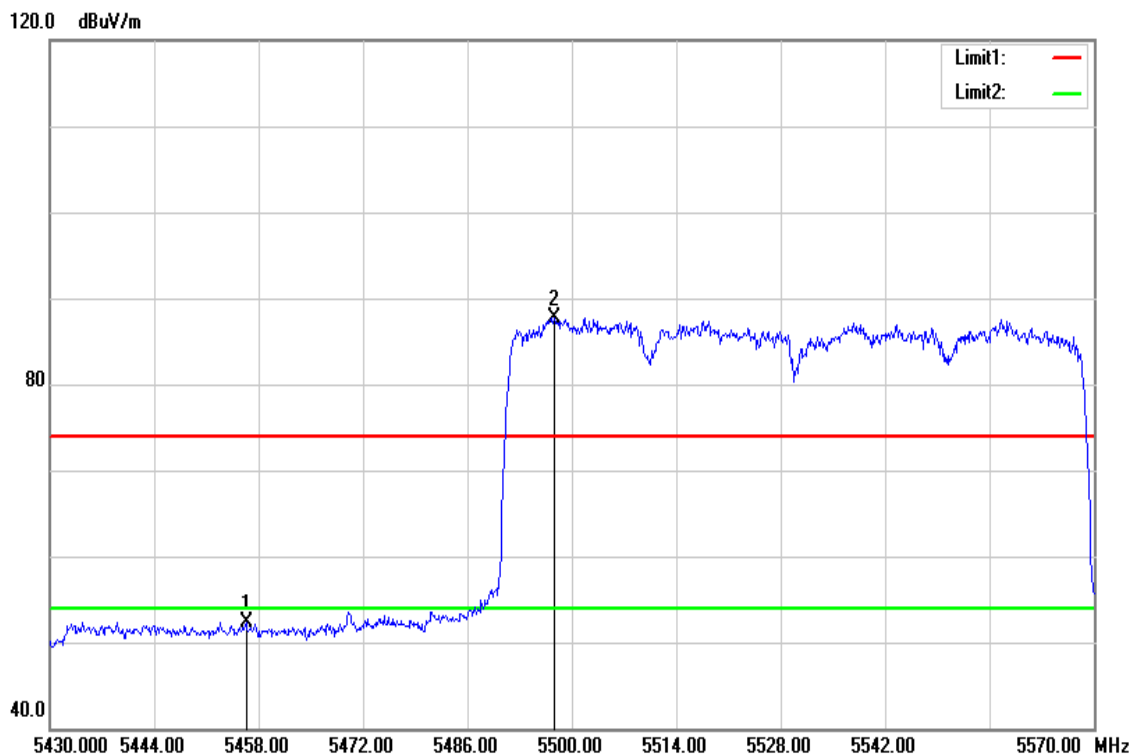

Frequency (MHz)	Reading (dBuV)	Correct Factor (dB/m)	Result (dBuV/m)	Limit (dBuV/m)	Margin (dB)	Remark
5456.320	46.50	5.82	52.32	54.00	-1.68	AVG
5497.620	81.81	5.93	87.74	-	-	AVG

Test Mode	IEEE 802.11ac VHT80 / 5690 MHz	Temp/Hum	24(°C)/ 33%RH
Test Item	Band Edge	Test Date	November 28, 2017
Polarize	Vertical	Test Engineer	Jerry Chuang
Detector	Peak	Test Voltage	120Vac / 60Hz

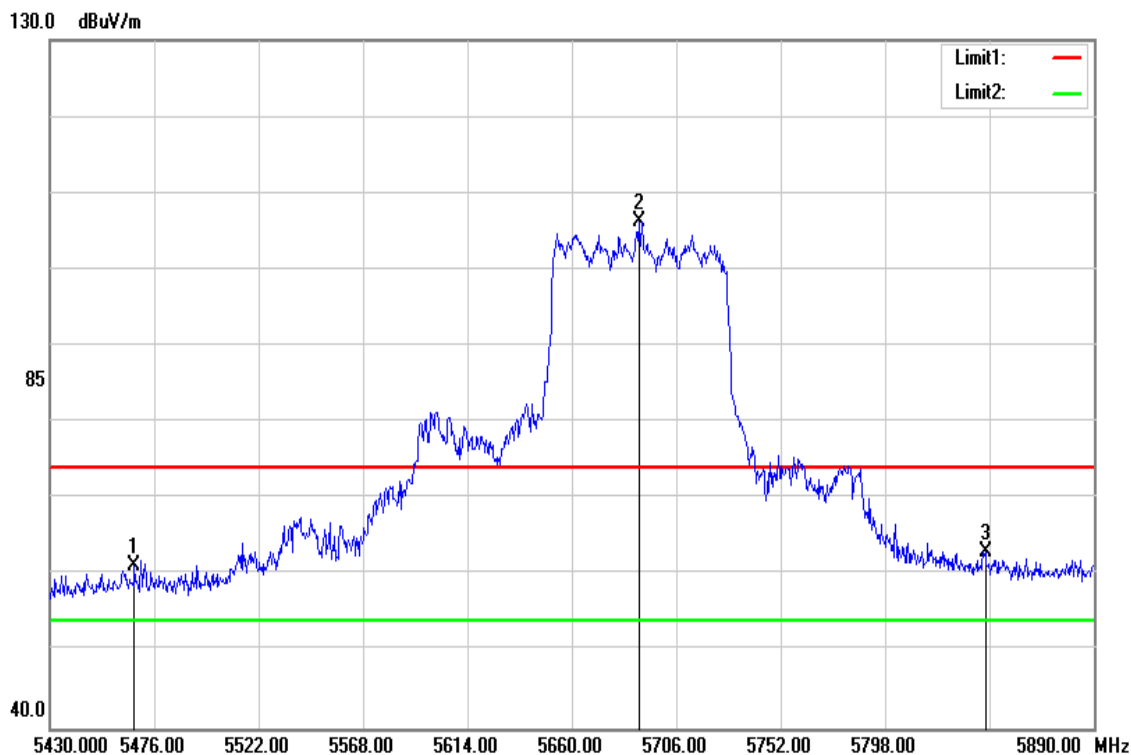

Frequency (MHz)	Reading (dBuV)	Correct Factor (dB/m)	Result (dBuV/m)	Limit (dBuV/m)	Margin (dB)	Remark
5467.260	55.35	5.85	61.20	74.00	-12.80	peak
5689.440	99.93	6.43	106.36	-	-	peak
5842.160	56.33	6.82	63.15	74.00	-10.85	peak

Test Mode	IEEE 802.11ac VHT80 / 5690 MHz	Temperature	24(°C)/ 33%RH
Test Item	Band Edge	Test Date	November 28, 2017
Polarize	Vertical	Test Engineer	Jerry Chuang
Detector	Average	Test Voltage	120Vac / 60Hz

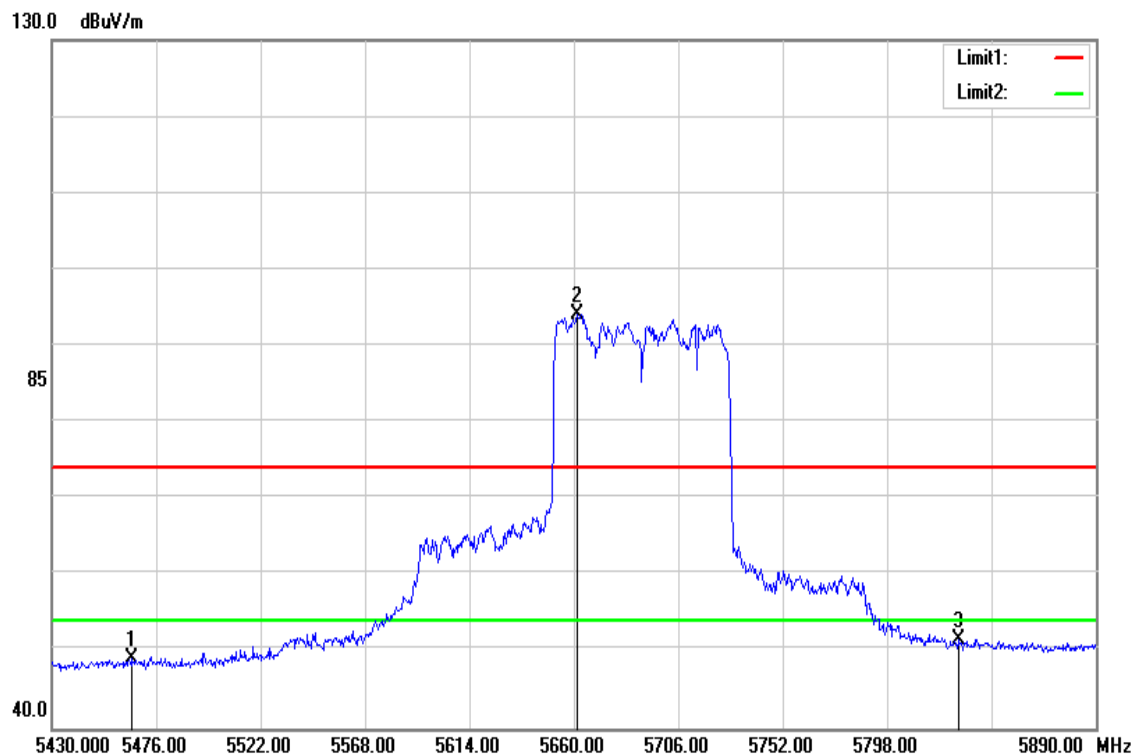

Frequency (MHz)	Reading (dBuV)	Correct Factor (dB/m)	Result (dBuV/m)	Limit (dBuV/m)	Margin (dB)	Remark
5465.420	43.16	5.85	49.01	54.00	-4.99	AVG
5661.380	87.71	6.35	94.06	-	-	AVG
5829.280	44.89	6.80	51.69	54.00	-2.31	AVG

Band Edge Test Data for UNII-3

Test Mode	IEEE 802.11a / 5745 MHz	Temp/Hum	24(°C)/ 33%RH
Test Item	Band Edge	Test Date	November 28, 2017
Polarize	Vertical	Test Engineer	Jerry Chuang
Detector	Peak	Test Voltage	120Vac / 60Hz

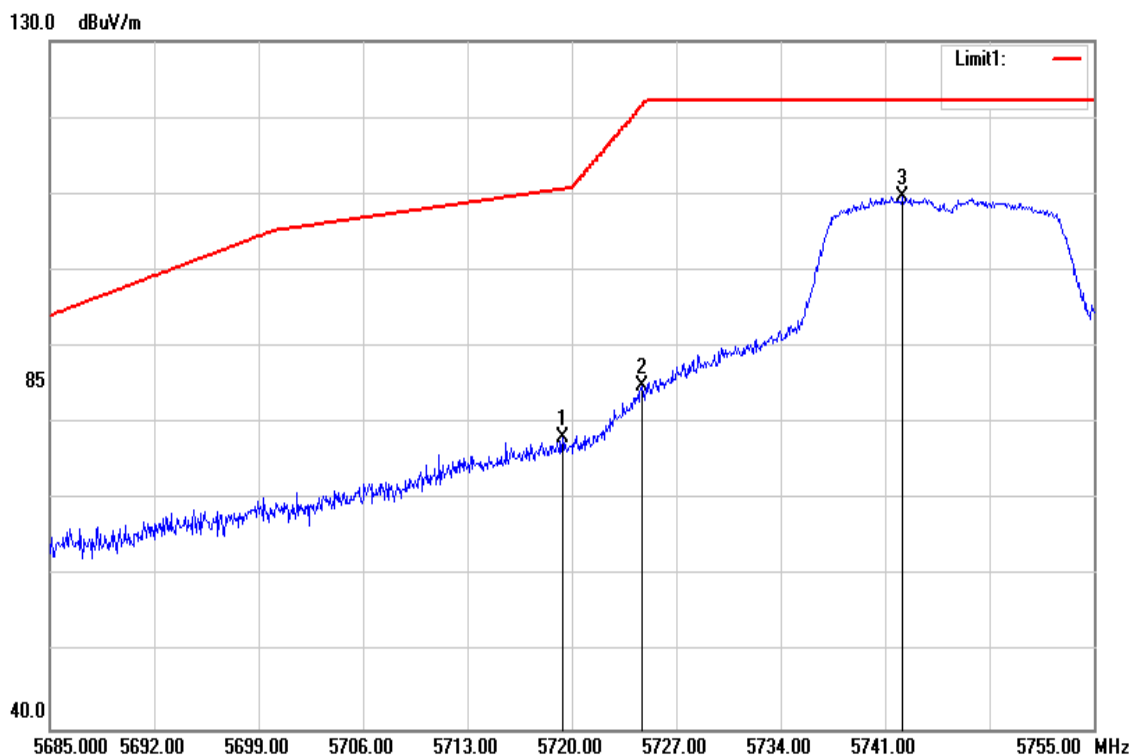

Frequency (MHz)	Reading (dBuV)	Correct Factor (dB/m)	Result (dBuV/m)	Limit (dBuV/m)	Margin (dB)	Remark
5719.370	71.55	6.50	78.05	110.62	-32.57	peak
5724.690	78.40	6.52	84.92	121.49	-36.57	peak
5742.190	103.09	6.56	109.65	-	-	peak

Test Mode	IEEE 802.11a / 5745 MHz	Temp/Hum	24(°C)/ 33%RH
Test Item	Band Edge	Test Date	November 28, 2017
Polarize	Vertical	Test Engineer	Jerry Chuang
Detector	Average	Test Voltage	120Vac / 60Hz

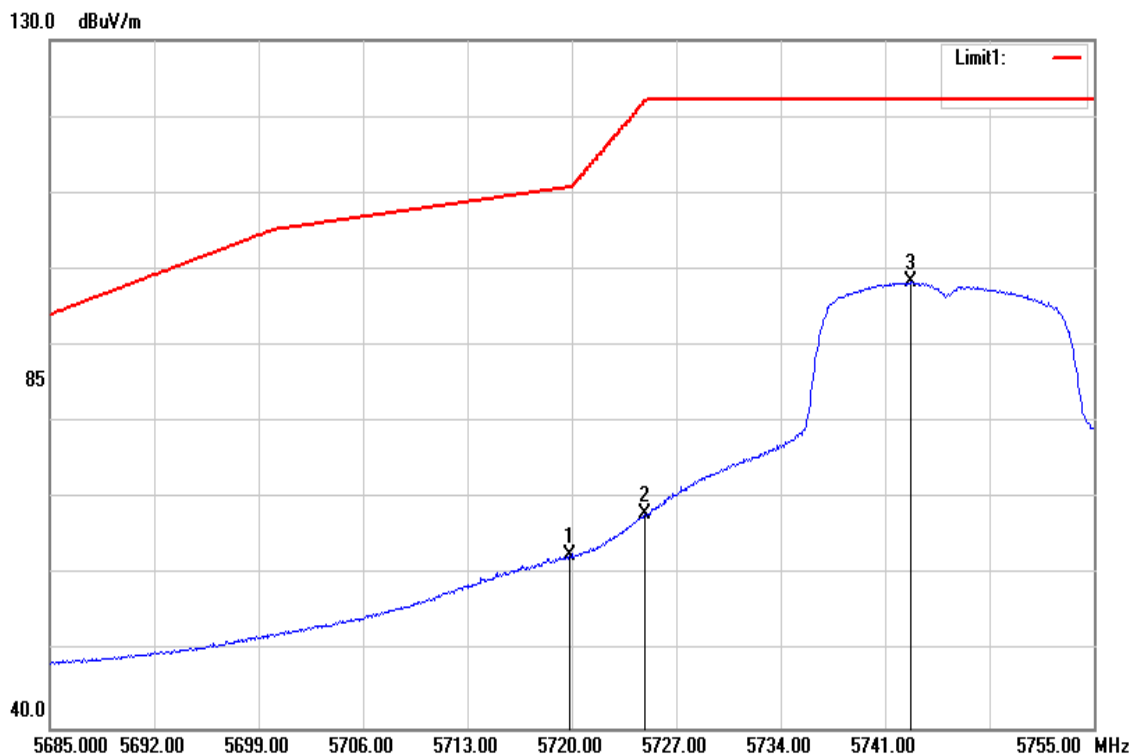

Frequency (MHz)	Reading (dBuV)	Correct Factor (dB/m)	Result (dBuV/m)	Limit (dBuV/m)	Margin (dB)	Remark
5719.860	56.01	6.50	62.51	110.76	-48.25	AVG
5724.900	61.51	6.52	68.03	121.97	-53.94	AVG
5742.750	91.77	6.57	98.34	-	-	AVG

Test Mode	IEEE 802.11a / 5825 MHz	Temp/Hum	24(°C)/ 33%RH
Test Item	Band Edge	Test Date	November 28, 2017
Polarize	Vertical	Test Engineer	Jerry Chuang
Detector	Peak	Test Voltage	120Vac / 60Hz

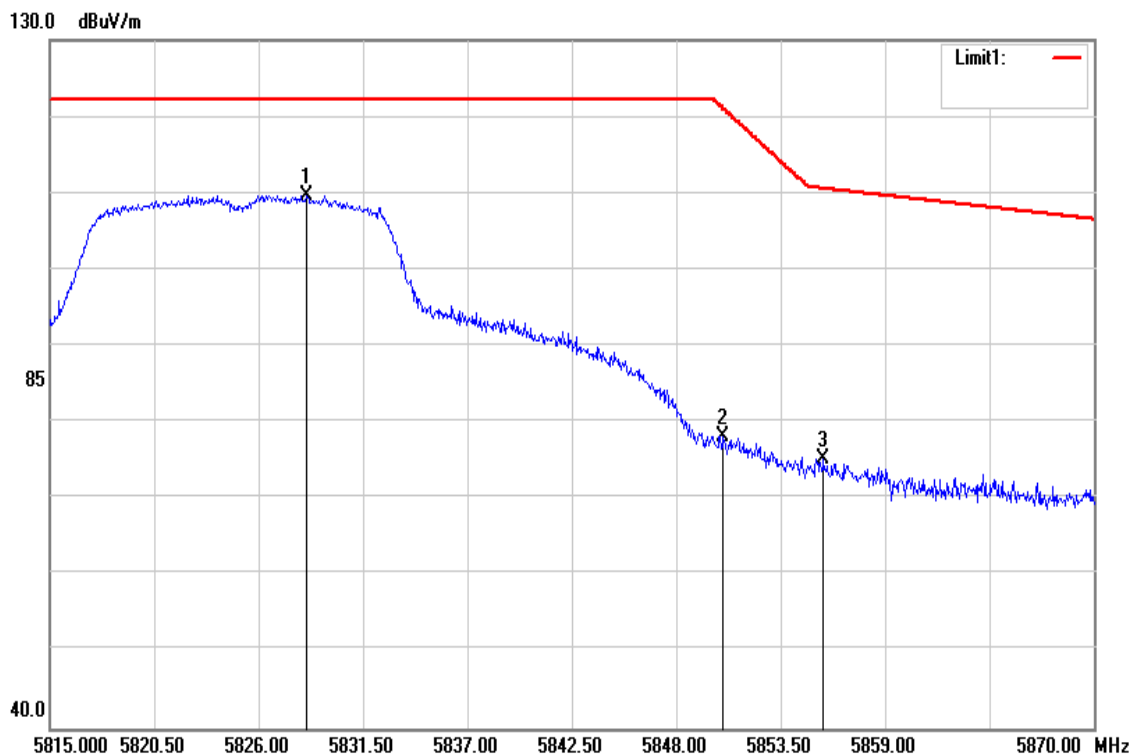

Frequency (MHz)	Reading (dBuV)	Correct Factor (dB/m)	Result (dBuV/m)	Limit (dBuV/m)	Margin (dB)	Remark
5828.530	102.94	6.79	109.73	-	-	peak
5850.475	71.26	6.85	78.11	121.12	-43.01	peak
5855.755	68.43	6.86	75.29	110.59	-35.30	peak

Test Mode	IEEE 802.11a / 5825 MHz	Temp/Hum	24(°C)/ 33%RH
Test Item	Band Edge	Test Date	November 28, 2017
Polarize	Vertical	Test Engineer	Jerry Chuang
Detector	Average	Test Voltage	120Vac / 60Hz

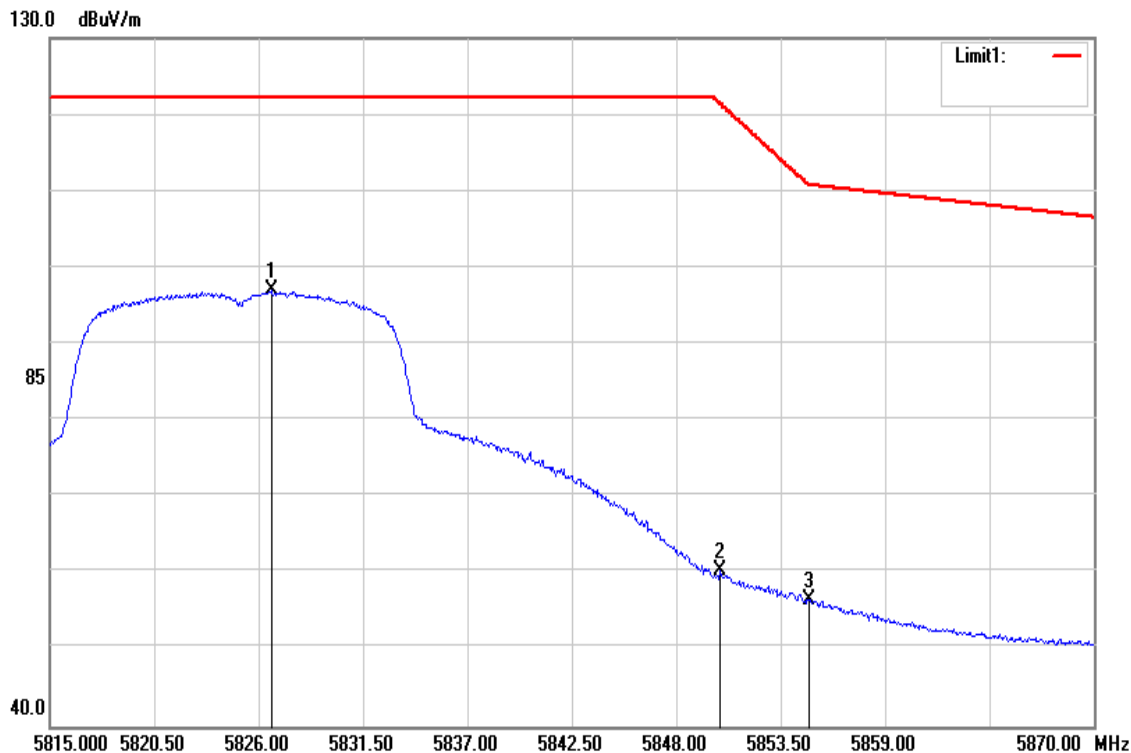

Frequency (MHz)	Reading (dBuV)	Correct Factor (dB/m)	Result (dBuV/m)	Limit (dBuV/m)	Margin (dB)	Remark
5826.660	90.30	6.78	97.08	-	-	AVG
5850.310	53.45	6.85	60.30	121.49	-61.19	AVG
5854.985	49.72	6.86	56.58	110.83	-54.25	AVG

Test Mode	IEEE 802.11n HT20 / 5745 MHz	Temp/Hum	24(°C)/ 33%RH
Test Item	Band Edge	Test Date	November 28, 2017
Polarize	Vertical	Test Engineer	Jerry Chuang
Detector	Peak	Test Voltage	120Vac / 60Hz

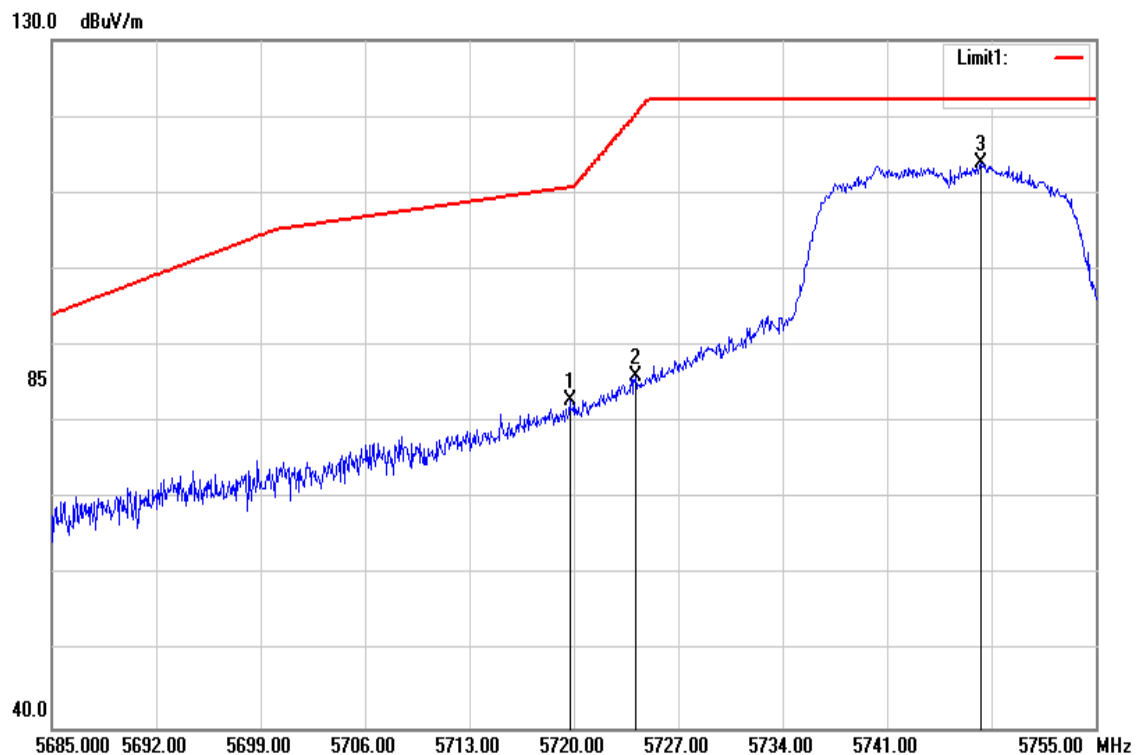

Frequency (MHz)	Reading (dBuV)	Correct Factor (dB/m)	Result (dBuV/m)	Limit (dBuV/m)	Margin (dB)	Remark
5719.720	76.39	6.50	82.89	110.72	-27.83	peak
5724.130	79.40	6.52	85.92	120.22	-34.30	peak
5747.300	107.38	6.58	113.96	-	-	peak

Test Mode	IEEE 802.11n HT20 / 5745 MHz	Temp/Hum	24(°C)/ 33%RH
Test Item	Band Edge	Test Date	November 28, 2017
Polarize	Vertical	Test Engineer	Jerry Chuang
Detector	Average	Test Voltage	120Vac / 60Hz

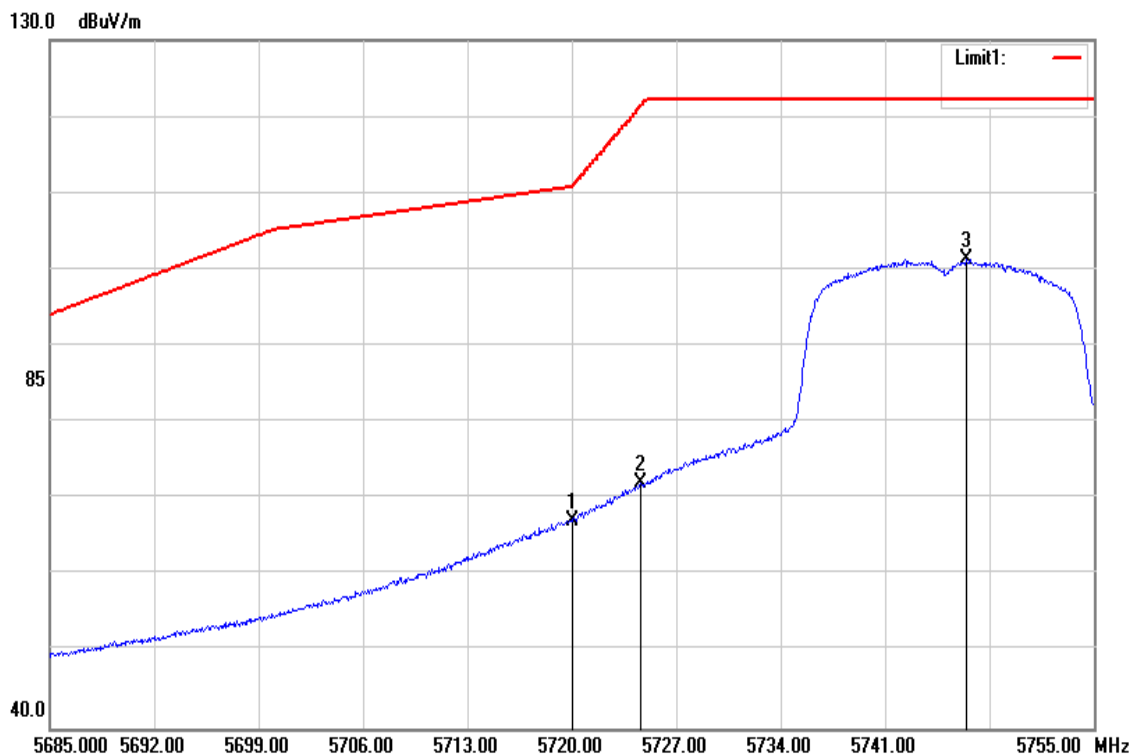

Frequency (MHz)	Reading (dBuV)	Correct Factor (dB/m)	Result (dBuV/m)	Limit (dBuV/m)	Margin (dB)	Remark
5720.070	60.68	6.50	67.18	110.96	-43.78	AVG
5724.620	65.48	6.52	72.00	121.33	-49.33	AVG
5746.460	94.65	6.58	101.23	-	-	AVG

Test Mode	IEEE 802.11n HT20 / 5825 MHz	Temp/Hum	24(°C)/ 33%RH
Test Item	Band Edge	Test Date	November 28, 2017
Polarize	Vertical	Test Engineer	Jerry Chuang
Detector	Peak	Test Voltage	120Vac / 60Hz

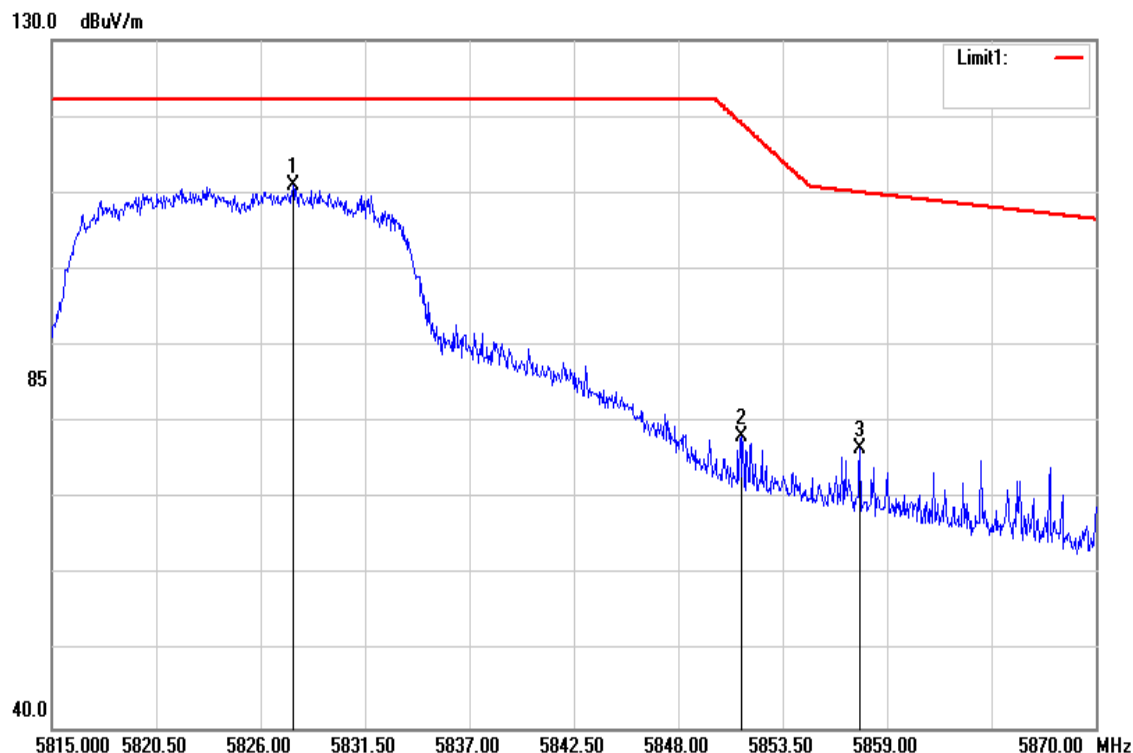

Frequency (MHz)	Reading (dBuV)	Correct Factor (dB/m)	Result (dBuV/m)	Limit (dBuV/m)	Margin (dB)	Remark
5827.705	104.12	6.79	110.91	-	-	peak
5851.355	71.35	6.85	78.20	119.11	-40.91	peak
5857.570	69.65	6.87	76.52	110.08	-33.56	peak

Test Mode	IEEE 802.11n HT20 / 5825 MHz	Temp/Hum	24(°C)/ 33%RH
Test Item	Band Edge	Test Date	November 28, 2017
Polarize	Vertical	Test Engineer	Jerry Chuang
Detector	Average	Test Voltage	120Vac / 60Hz

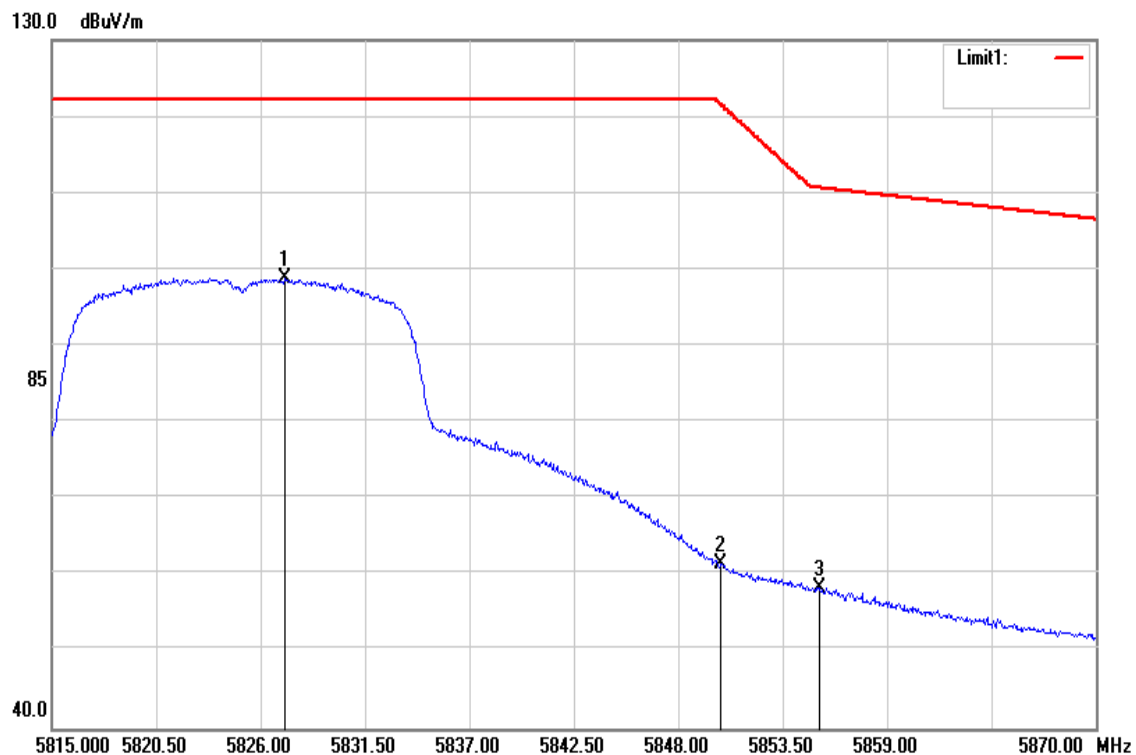

Frequency (MHz)	Reading (dBuV)	Correct Factor (dB/m)	Result (dBuV/m)	Limit (dBuV/m)	Margin (dB)	Remark
5827.265	92.09	6.78	98.87	-	-	AVG
5850.255	54.62	6.85	61.47	121.62	-60.15	AVG
5855.425	51.52	6.86	58.38	110.68	-52.30	AVG

Test Mode	IEEE 802.11n HT20 / 5720 MHz	Temp/Hum	24(°C)/ 33%RH
Test Item	Band Edge	Test Date	November 28, 2017
Polarize	Vertical	Test Engineer	Jerry Chuang
Detector	Peak	Test Voltage	120Vac / 60Hz

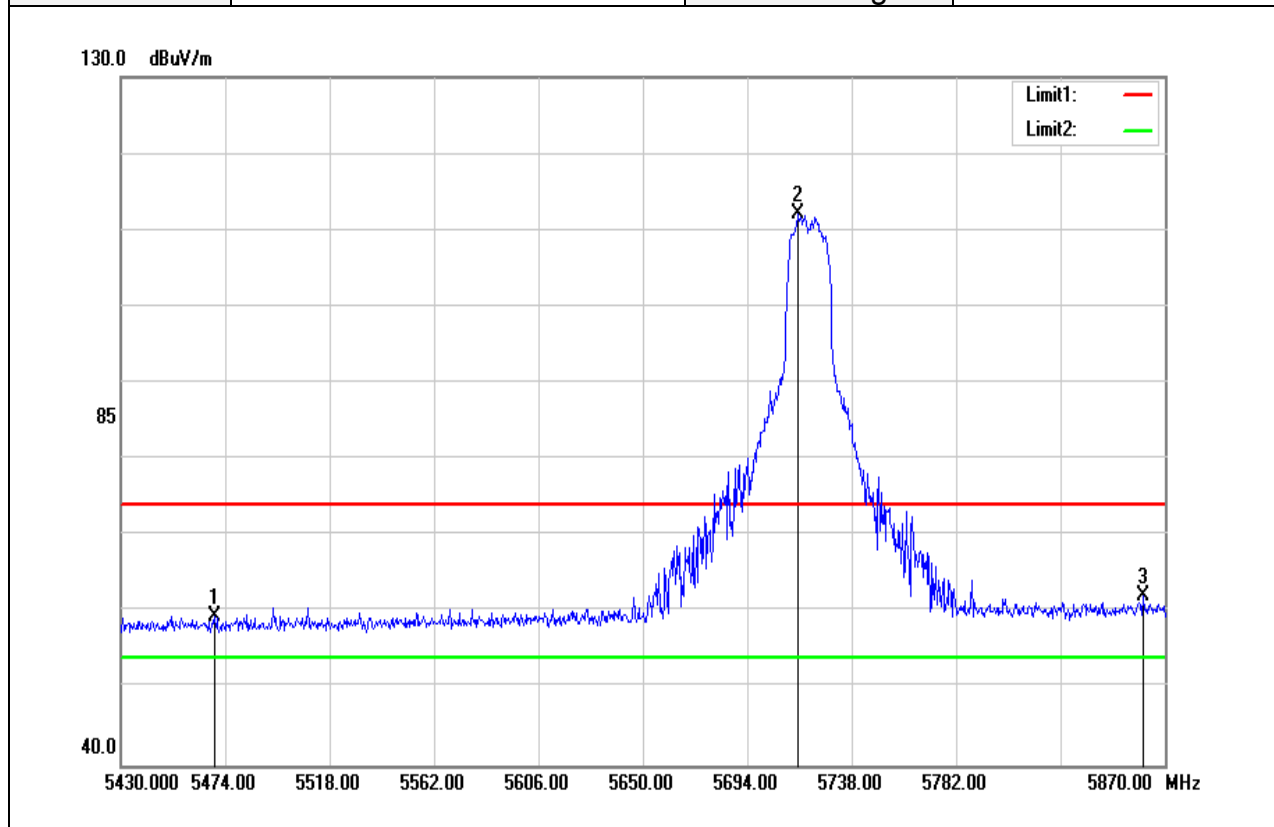

Frequency (MHz)	Reading (dBuV)	Correct Factor (dB/m)	Result (dBuV/m)	Limit (dBuV/m)	Margin (dB)	Remark
5469.600	53.59	5.85	59.44	74.00	-14.56	peak
5715.560	105.54	6.49	112.03	-	-	peak
5860.760	55.29	6.87	62.16	74.00	-11.84	peak

Test Mode	IEEE 802.11n HT20 / 5720 MHz	Temp/Hum	24(°C)/ 33%RH
Test Item	Band Edge	Test Date	November 28, 2017
Polarize	Vertical	Test Engineer	Jerry Chuang
Detector	Average	Test Voltage	120Vac / 60Hz

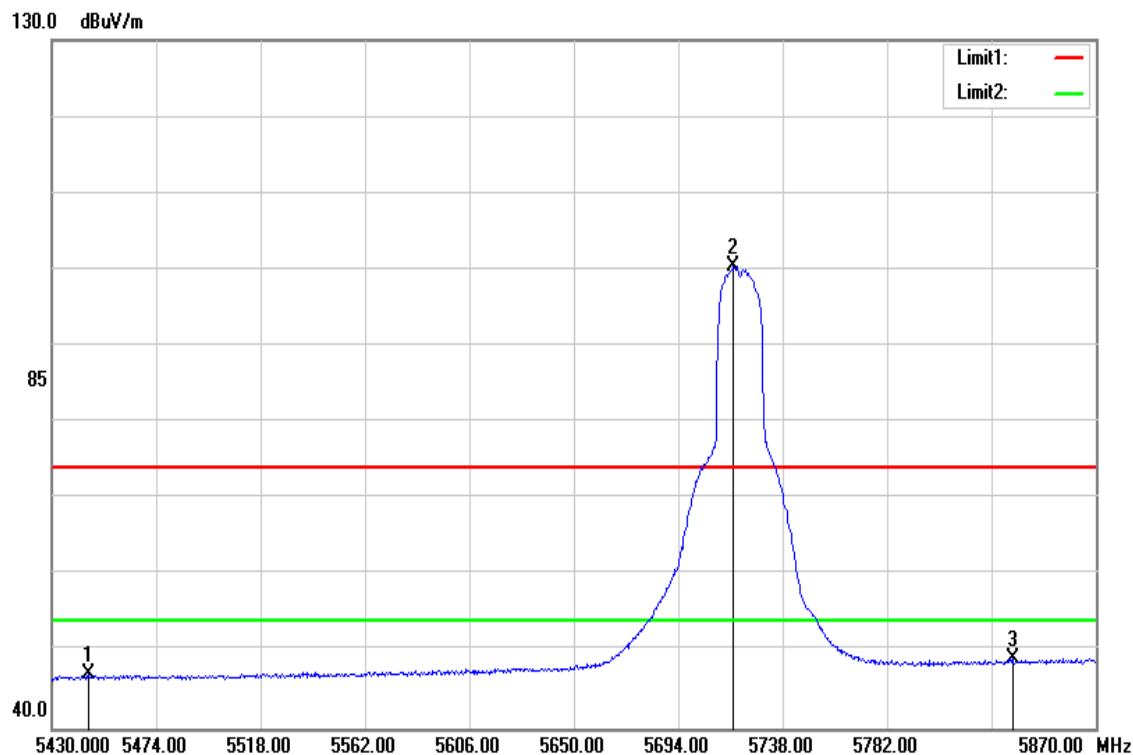

Frequency (MHz)	Reading (dBuV)	Correct Factor (dB/m)	Result (dBuV/m)	Limit (dBuV/m)	Margin (dB)	Remark
5445.400	41.18	5.80	46.98	54.00	-7.02	AVG
5717.320	93.86	6.49	100.35	-	-	AVG
5834.800	42.36	6.81	49.17	54.00	-4.83	AVG

Test Mode	IEEE 802.11n HT40/ 5755 MHz	Temp/Hum	24(°C)/ 33%RH
Test Item	Band Edge	Test Date	November 28, 2017
Polarize	Vertical	Test Engineer	Jerry Chuang
Detector	Peak	Test Voltage	120Vac / 60Hz

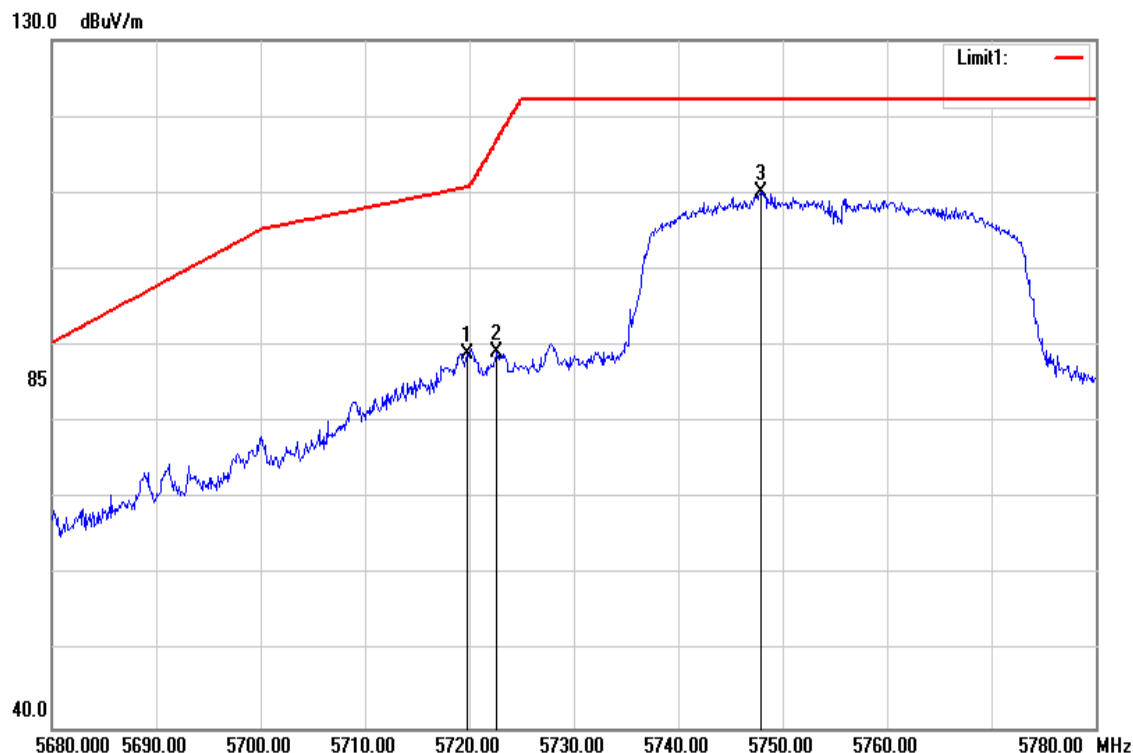

Frequency (MHz)	Reading (dBuV)	Correct Factor (dB/m)	Result (dBuV/m)	Limit (dBuV/m)	Margin (dB)	Remark
5719.800	82.46	6.50	88.96	110.74	-21.78	peak
5722.600	82.58	6.52	89.10	116.73	-27.63	peak
5747.900	103.52	6.59	110.11	-	-	peak

Test Mode	IEEE 802.11n HT40/ 5755 MHz	Temp/Hum	24(°C)/ 33%RH
Test Item	Band Edge	Test Date	November 28, 2017
Polarize	Vertical	Test Engineer	Jerry Chuang
Detector	Average	Test Voltage	120Vac / 60Hz

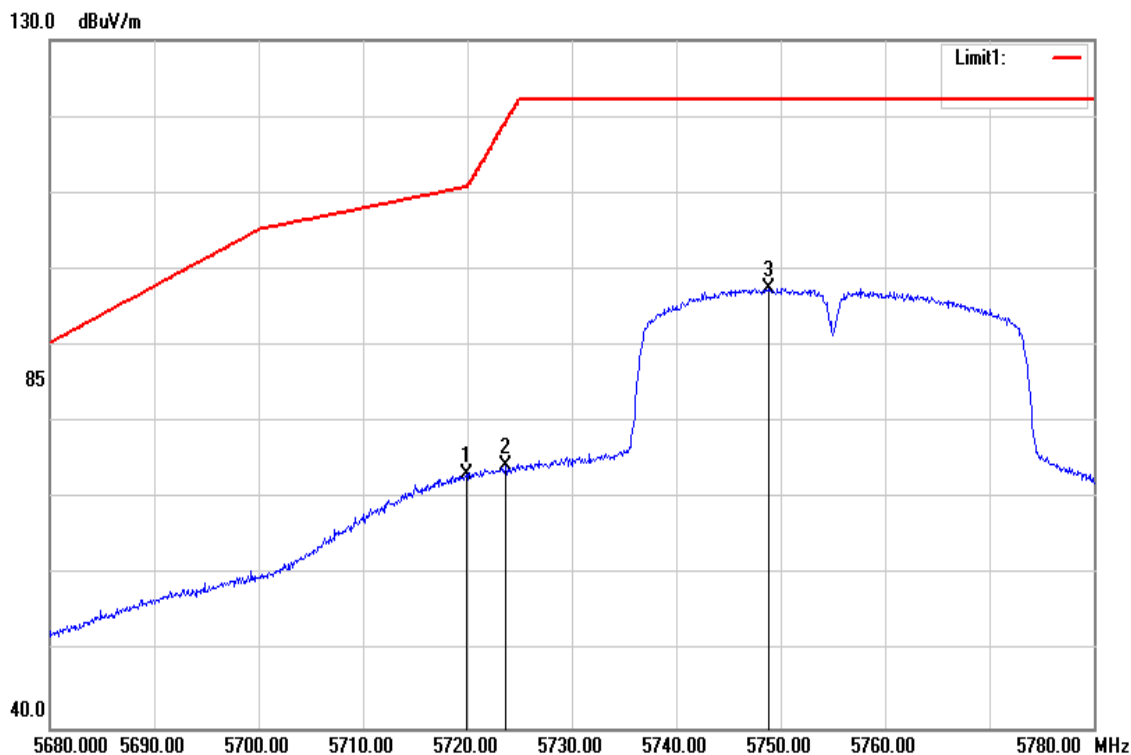

Frequency (MHz)	Reading (dBuV)	Correct Factor (dB/m)	Result (dBuV/m)	Limit (dBuV/m)	Margin (dB)	Remark
5719.900	66.66	6.50	73.16	110.77	-37.61	AVG
5723.700	67.78	6.52	74.30	119.24	-44.94	AVG
5748.900	90.97	6.59	97.56	-	-	AVG

Test Mode	IEEE 802.11n HT40/ 5795 MHz	Temp/Hum	24(°C)/ 33%RH
Test Item	Band Edge	Test Date	November 28, 2017
Polarize	Vertical	Test Engineer	Jerry Chuang
Detector	Peak	Test Voltage	120Vac / 60Hz

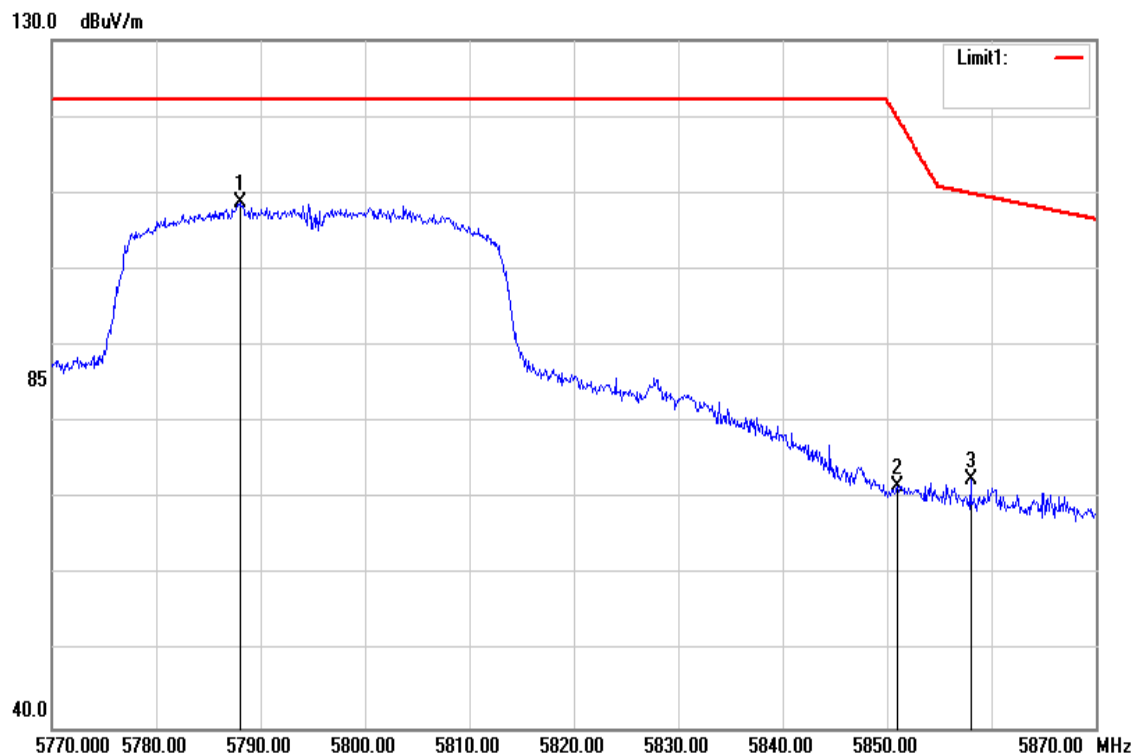

Frequency (MHz)	Reading (dBuV)	Correct Factor (dB/m)	Result (dBuV/m)	Limit (dBuV/m)	Margin (dB)	Remark
5788.000	101.94	6.69	108.63	-	-	peak
5851.000	64.87	6.85	71.72	119.92	-48.20	peak
5858.000	65.65	6.87	72.52	109.96	-37.44	peak

Test Mode	IEEE 802.11n HT40/ 5795 MHz	Temp/Hum	24(°C)/ 33%RH
Test Item	Band Edge	Test Date	November 28, 2017
Polarize	Vertical	Test Engineer	Jerry Chuang
Detector	Average	Test Voltage	120Vac / 60Hz

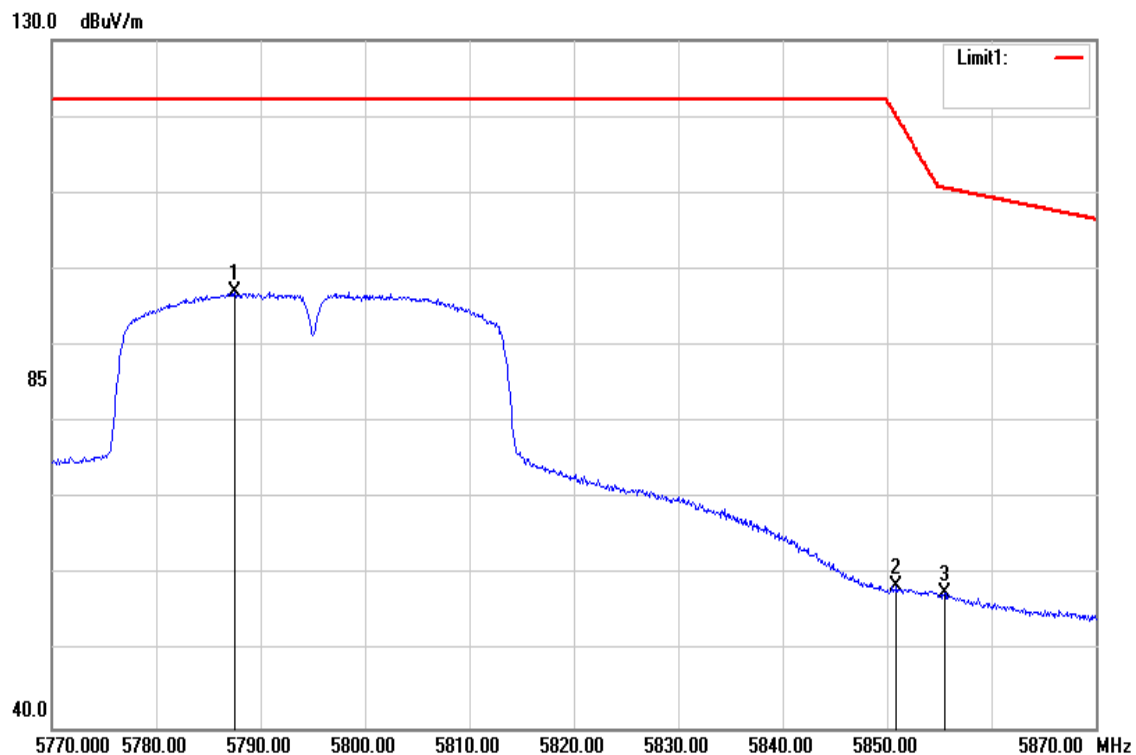

Frequency (MHz)	Reading (dBuV)	Correct Factor (dB/m)	Result (dBuV/m)	Limit (dBuV/m)	Margin (dB)	Remark
5787.500	90.27	6.69	96.96	-	-	AVG
5850.900	51.62	6.85	58.47	120.15	-61.68	AVG
5855.500	50.83	6.86	57.69	110.66	-52.97	AVG

Test Mode	IEEE 802.11ac VHT80 / 5775 MHz	Temp/Hum	24(°C)/ 33%RH
Test Item	Band Edge	Test Date	Mar 24, 2017
Polarize	Vertical	Test Engineer	Jerry Chuang
Detector	Peak	Test Voltage	120Vac / 60Hz

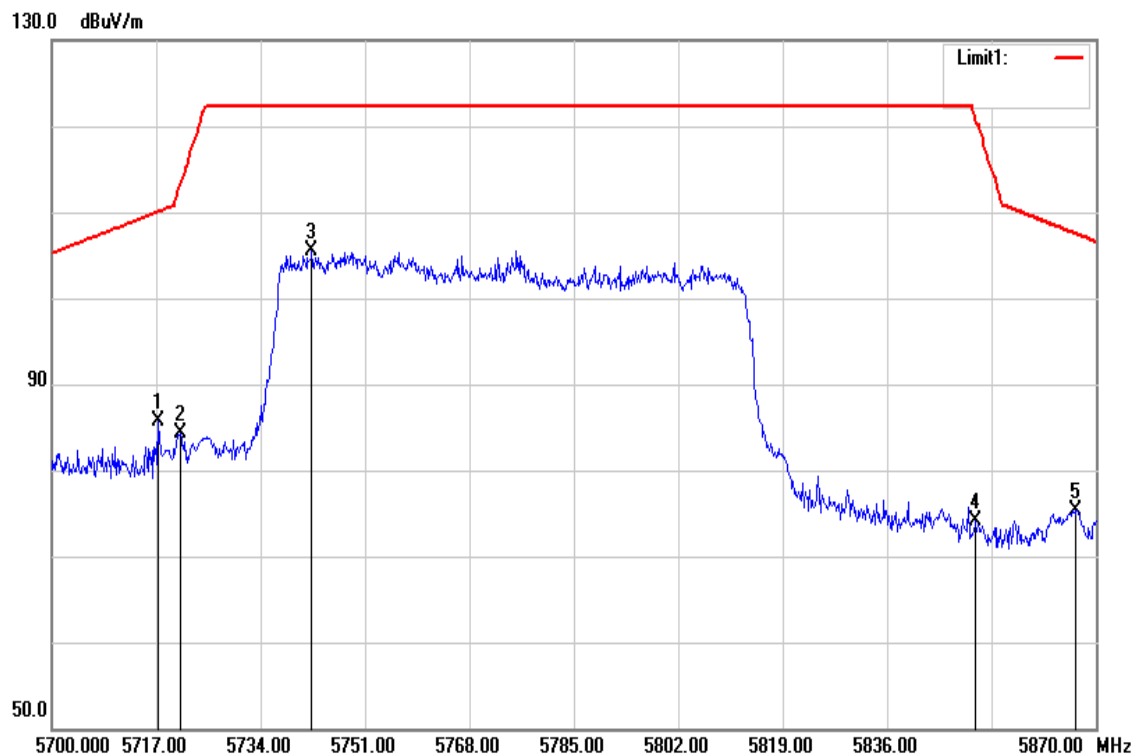

Frequency (MHz)	Reading (dBuV)	Correct Factor (dB/m)	Result (dBuV/m)	Limit (dBuV/m)	Margin (dB)	Remark
5717.340	79.26	6.49	85.75	110.06	-24.31	peak
5720.910	77.76	6.51	84.27	112.87	-28.60	peak
5742.330	98.86	6.56	105.42	-	-	peak
5850.450	67.16	6.85	74.01	121.17	-47.16	peak
5866.600	68.49	6.89	75.38	107.55	-32.17	peak

Test Mode	IEEE 802.11ac VHT80 / 5775 MHz	Temp/Hum	24(°C)/ 33%RH
Test Item	Band Edge	Test Date	Mar 24, 2017
Polarize	Vertical	Test Engineer	Jerry Chuang
Detector	Average	Test Voltage	120Vac / 60Hz

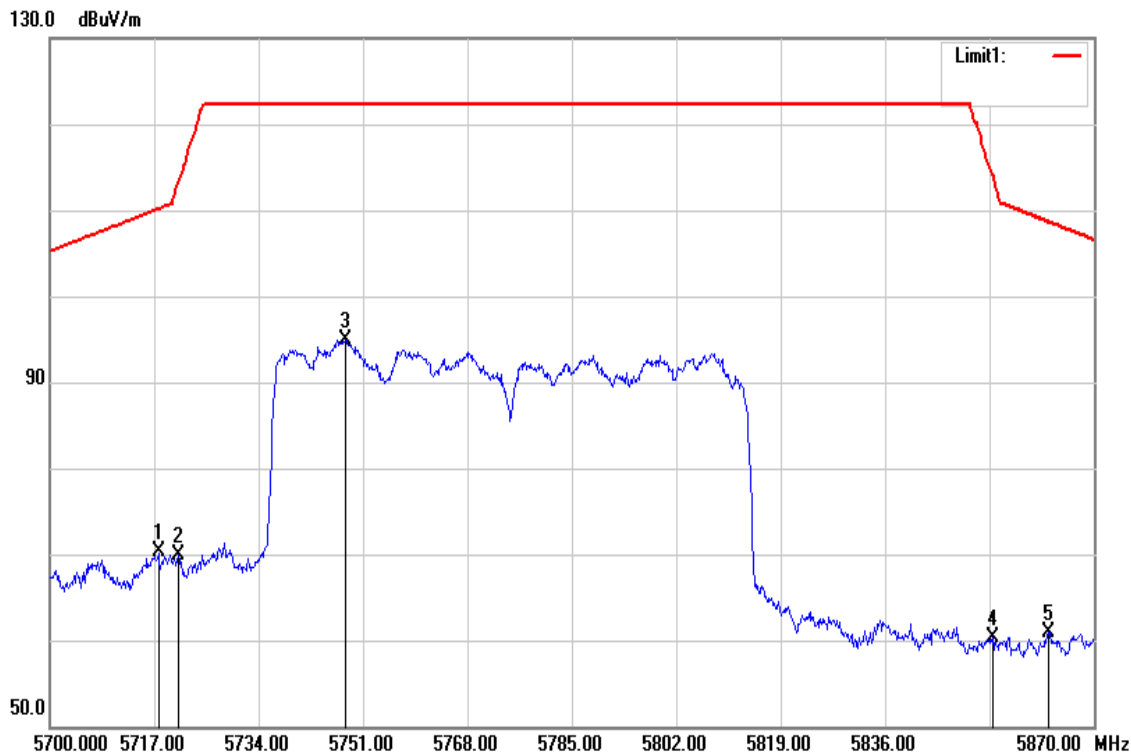

Frequency (MHz)	Reading (dBuV)	Correct Factor (dB/m)	Result (dBuV/m)	Limit (dBuV/m)	Margin (dB)	Remark
5717.680	63.70	6.50	70.20	110.15	-39.95	AVG
5720.910	63.33	6.51	69.84	112.87	-43.03	AVG
5748.110	88.32	6.59	94.91	-	-	AVG
5853.510	53.50	6.85	60.35	114.20	-53.85	AVG
5862.520	53.95	6.89	60.84	108.69	-47.85	AVG

Below 1G Test Data

Test Mode	IEEE 802.11a / 5180MHZ	Temp/Hum	24(°C)/ 33%RH
Test Item	30MHz-1GHz	Test Date	November 30, 2017
Polarize	Horizontal	Test Engineer	Jerry Chuang
Detector	Peak and Quasi-peak	Test Voltage	120Vac / 60Hz

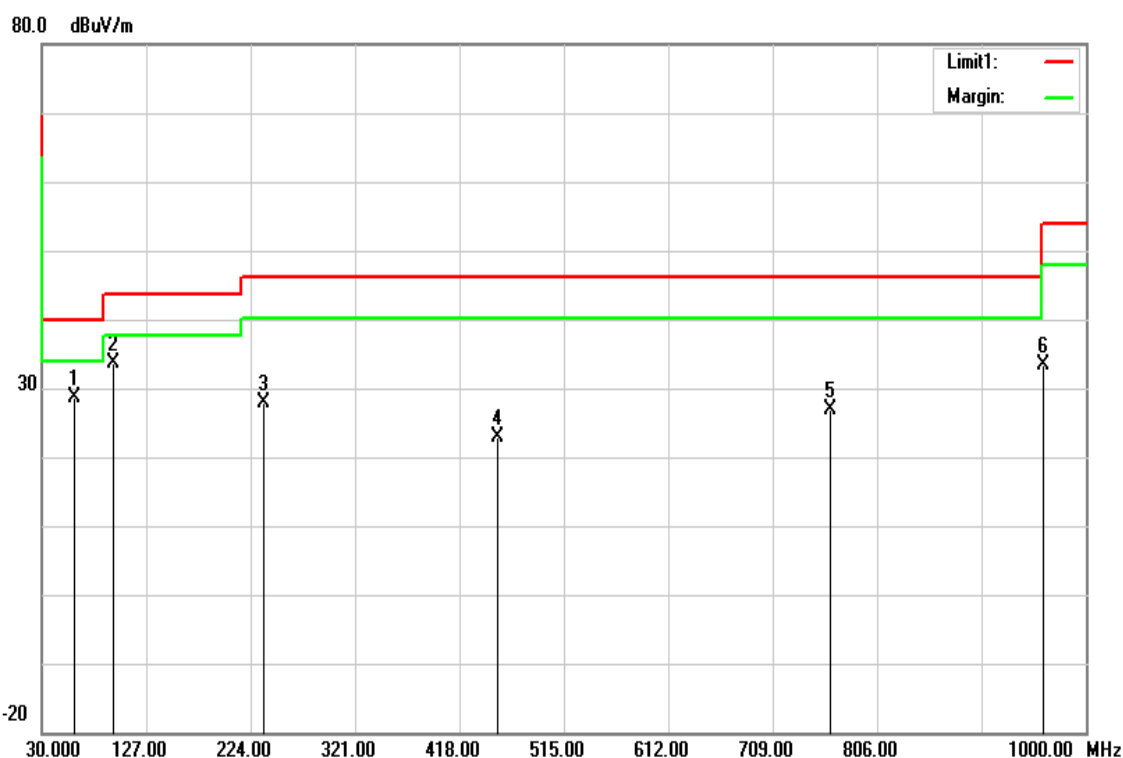

Frequency (MHz)	Reading (dBuV)	Correct Factor (dB/m)	Result (dBuV/m)	Limit (dBuV/m)	Margin (dB)	Remark
60.0700	50.43	-21.84	28.59	40.00	-11.41	peak
95.9600	53.32	-19.65	33.67	43.52	-9.85	peak
236.6100	44.14	-16.34	27.80	46.02	-18.22	peak
452.9200	32.53	-9.53	23.00	46.02	-23.02	peak
762.3500	30.95	-4.06	26.89	46.02	-19.13	peak
960.2300	34.58	-1.08	33.50	54.00	-20.50	peak

Note: No emission found between lowest internal used/generated frequency to 30MHz(9KHz~30MHz)

Test Mode	IEEE 802.11a / 5180MHZ	Temp/Hum	24(°C)/ 33%RH
Test Item	30MHz-1GHz	Test Date	November 30, 2017
Polarize	Horizontal	Test Engineer	Jerry Chuang
Detector	Peak and Quasi-peak	Test Voltage	120Vac / 60Hz

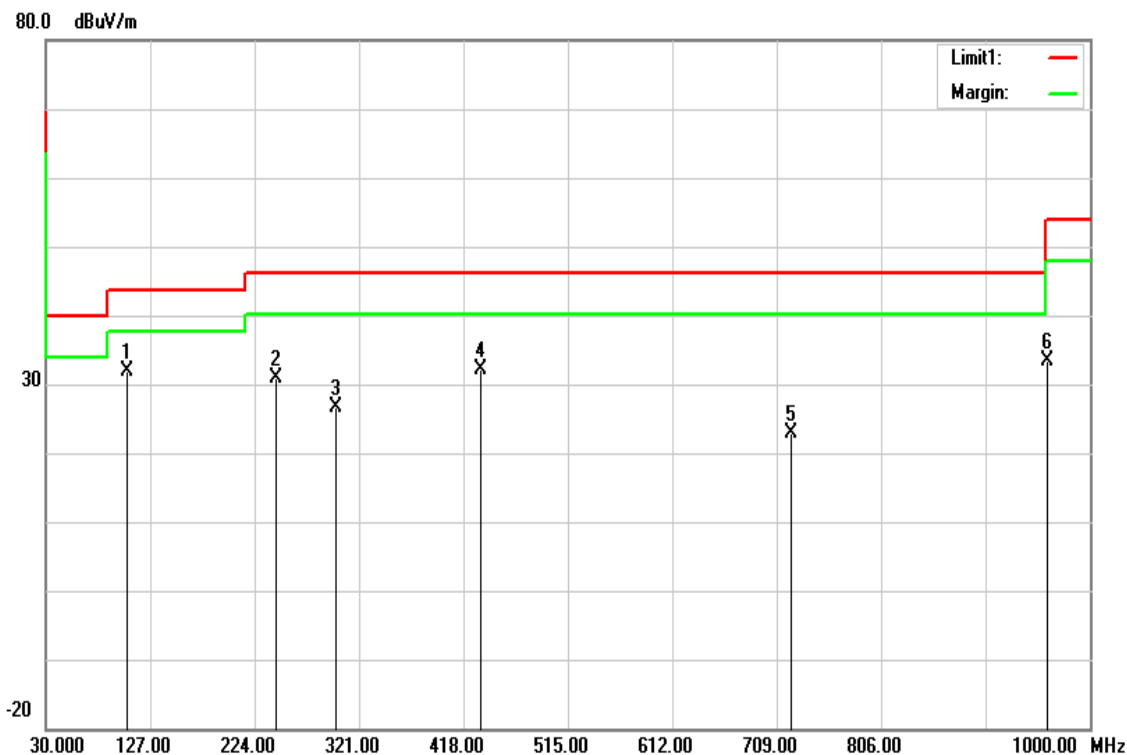

Frequency (MHz)	Reading (dBuV)	Correct Factor (dB/m)	Result (dBuV/m)	Limit (dBuV/m)	Margin (dB)	Remark
105.6600	49.42	-17.56	31.86	43.52	-11.66	peak
244.3700	46.98	-16.00	30.98	46.02	-15.04	peak
299.6600	40.80	-14.07	26.73	46.02	-19.29	peak
433.5200	42.29	-10.19	32.10	46.02	-13.92	peak
722.5800	27.40	-4.62	22.78	46.02	-23.24	peak
960.2300	34.58	-1.08	33.50	54.00	-20.50	peak

Note: No emission found between lowest internal used/generated frequency to 30MHz(9KHz~30MHz)

Above 1G Test Data for UNII-1

Test Mode	IEEE 802.11a / 5180MHZ	Temp/Hum	24(°C)/ 33%RH
Test Item	Harmonic	Test Date	November 30, 2017
Polarize	Horizontal	Test Engineer	Jerry Chuang
Detector	Peak and Average	Test Voltage	120Vac / 60Hz

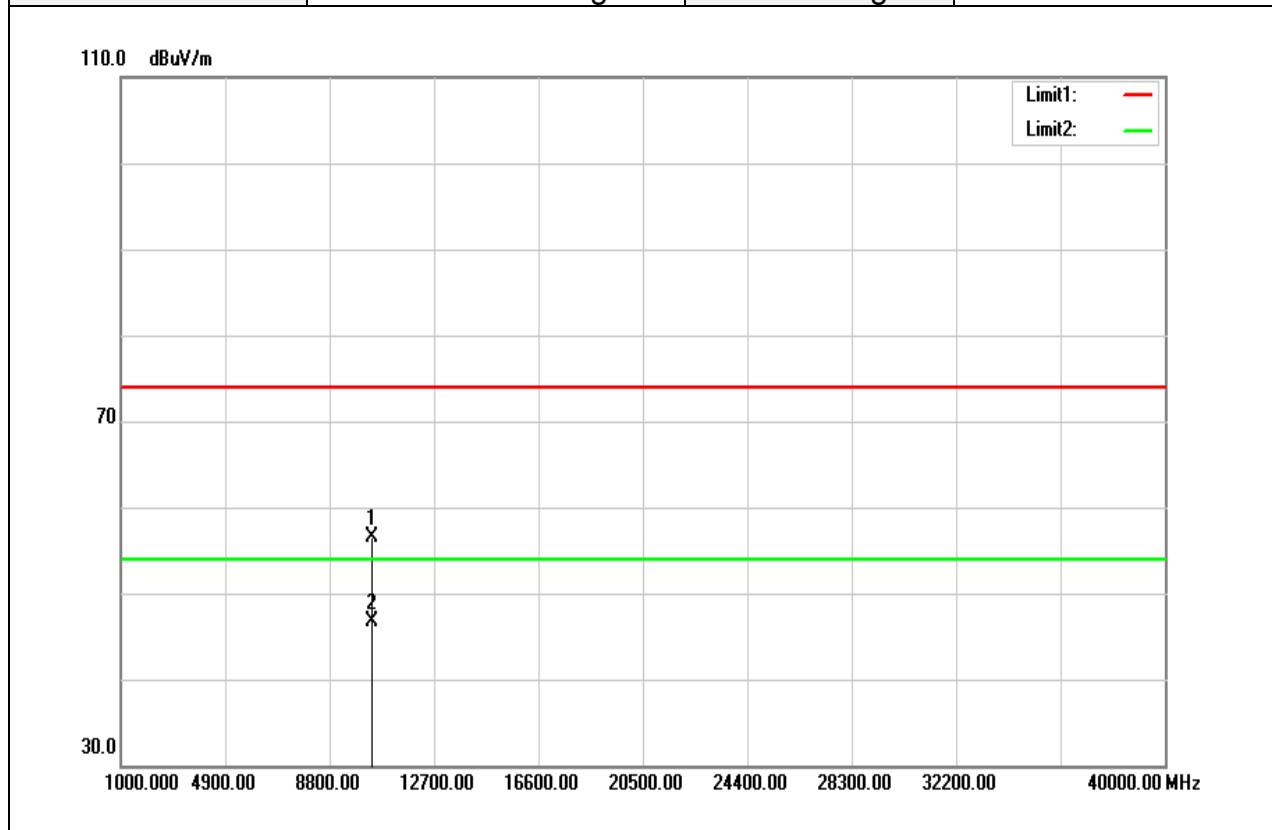

Frequency (MHz)	Reading (dBuV)	Correct Factor (dB/m)	Result (dBuV/m)	Limit (dBuV/m)	Margin (dB)	Remark
10360.000	41.96	14.45	56.41	74.00	-17.59	peak
10360.000	32.33	14.45	46.78	54.00	-7.22	AVG
N/A						

Remark:

1. Measuring frequencies from 1 GHz to the 10th harmonic of highest fundamental frequency.
2. For above 1GHz, the EUT peak value was under average limit, therefore the Average value compliance with the average limit

Test Mode	IEEE 802.11a / 5180MHZ	Temp/Hum	24(°C)/ 33%RH
Test Item	Harmonic	Test Date	November 30, 2017
Polarize	Horizontal	Test Engineer	Jerry Chuang
Detector	Peak and Average	Test Voltage	120Vac / 60Hz

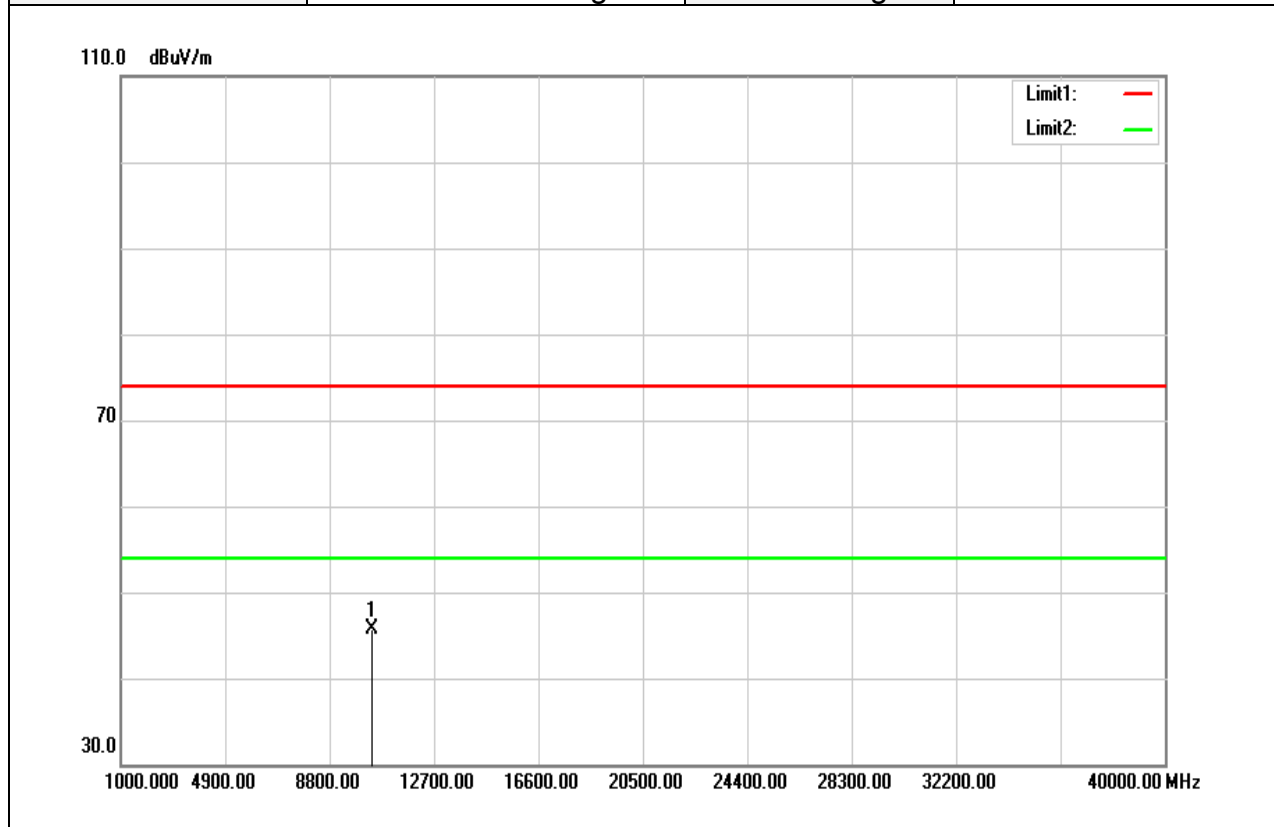

Frequency (MHz)	Reading (dBuV)	Correct Factor (dB/m)	Result (dBuV/m)	Limit (dBuV/m)	Margin (dB)	Remark
10360.000	31.26	14.45	45.71	74.00	-28.29	peak
N/A						

Remark:

1. Measuring frequencies from 1 GHz to the 10th harmonic of highest fundamental frequency.
2. For above 1GHz, the EUT peak value was under average limit, therefore the Average value compliance with the average limit

Test Mode	IEEE 802.11a / 5220 MHz	Temp/Hum	24(°C)/ 33%RH
Test Item	Horizontal	Test Date	November 30, 2017
Polarize	Vertical	Test Engineer	Jerry Chuang
Detector	Peak and Average	Test Voltage	120Vac / 60Hz

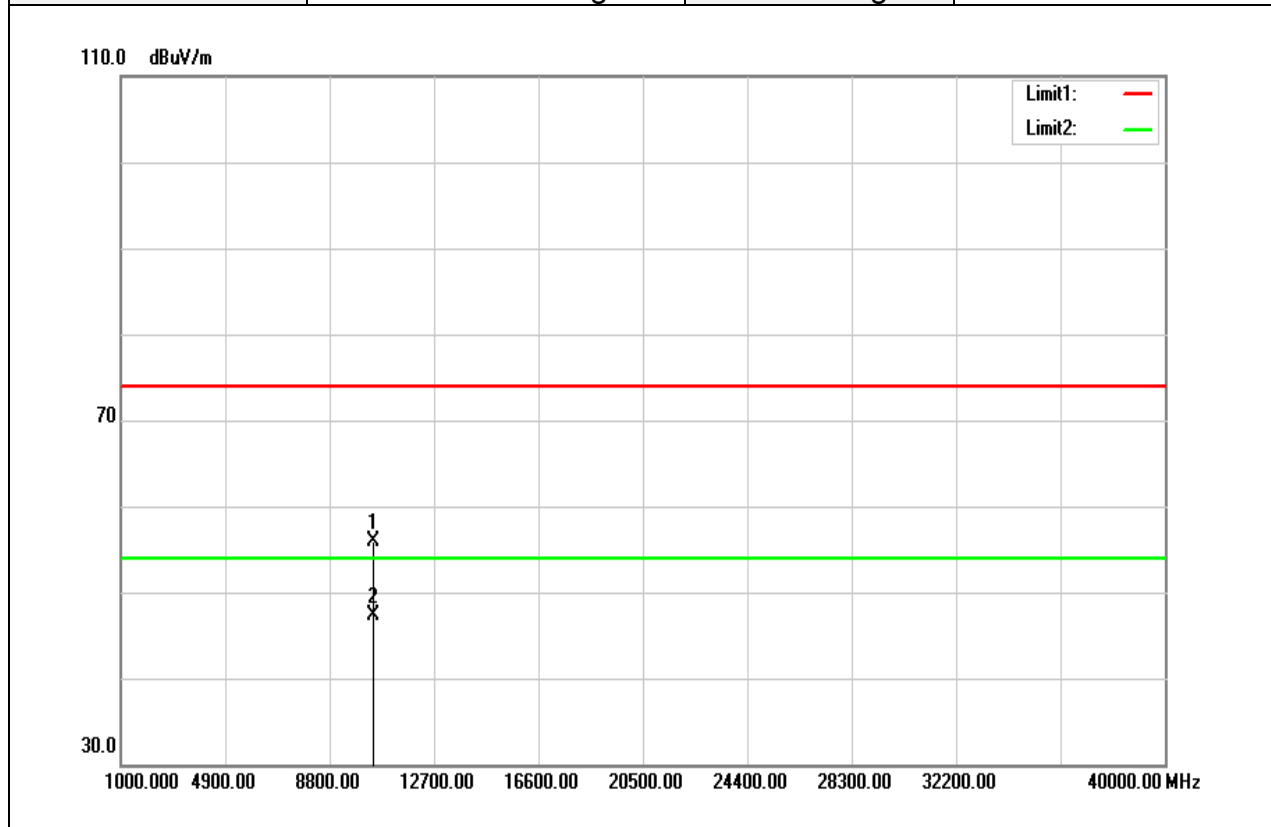

Frequency (MHz)	Reading (dBuV)	Correct Factor (dB/m)	Result (dBuV/m)	Limit (dBuV/m)	Margin (dB)	Remark
10440.000	41.16	14.71	55.87	74.00	-18.13	peak
10440.000	32.55	14.71	47.26	54.00	-6.74	AVG
N/A						

Remark:

1. Measuring frequencies from 1 GHz to the 10th harmonic of highest fundamental frequency.
2. For above 1GHz, the EUT peak value was under average limit, therefore the Average value compliance with the average limit

Test Mode	IEEE 802.11a / 5220 MHz	Temp/Hum	24(°C)/ 33%RH
Test Item	Harmonic	Test Date	November 30, 2017
Polarize	Horizontal	Test Engineer	Jerry Chuang
Detector	Peak and Average	Test Voltage	120Vac / 60Hz

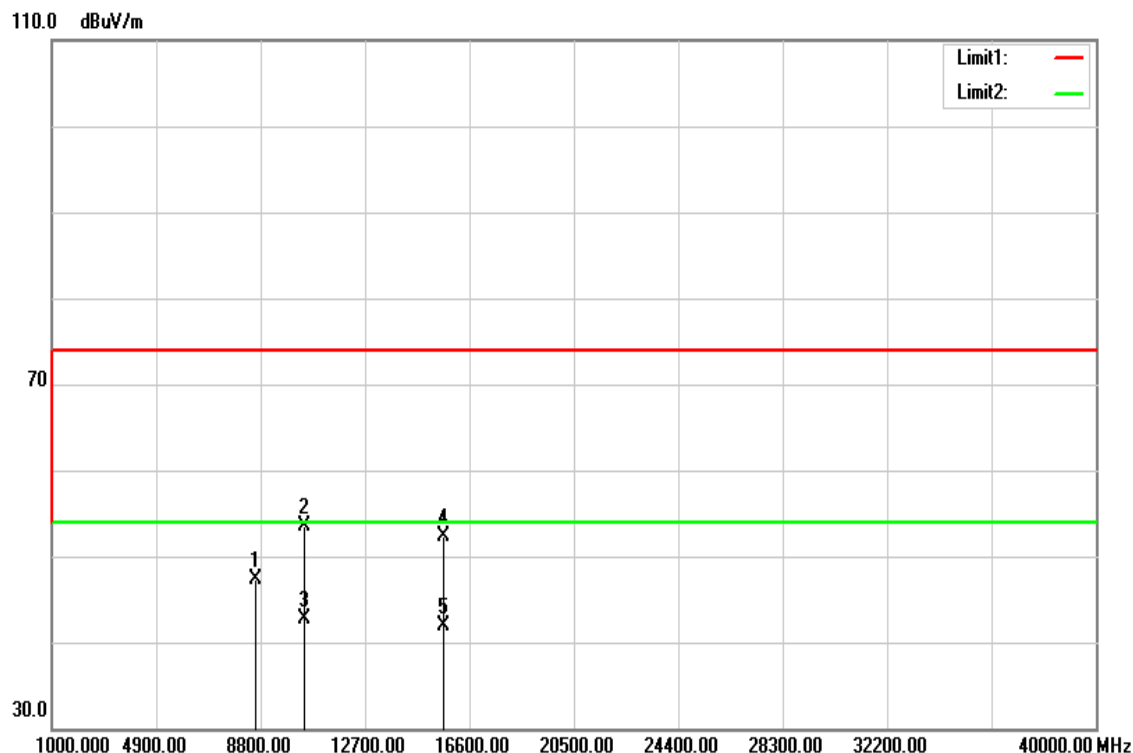

Frequency (MHz)	Reading (dBuV)	Correct Factor (dB/m)	Result (dBuV/m)	Limit (dBuV/m)	Margin (dB)	Remark
10440.000	37.41	14.71	52.12	74.00	-21.88	peak
10440.000	30.21	14.71	44.92	54.00	-9.08	AVG
N/A						

Remark:

1. Measuring frequencies from 1 GHz to the 10th harmonic of highest fundamental frequency.
2. For above 1GHz, the EUT peak value was under average limit, therefore the Average value compliance with the average limit

Test Mode	IEEE 802.11a / 5240MHZ	Temp/Hum	24(°C)/ 33%RH
Test Item	Harmonic	Test Date	November 30, 2017
Polarize	Vertical	Test Engineer	Jerry Chuang
Detector	Peak and Average	Test Voltage	120Vac / 60Hz

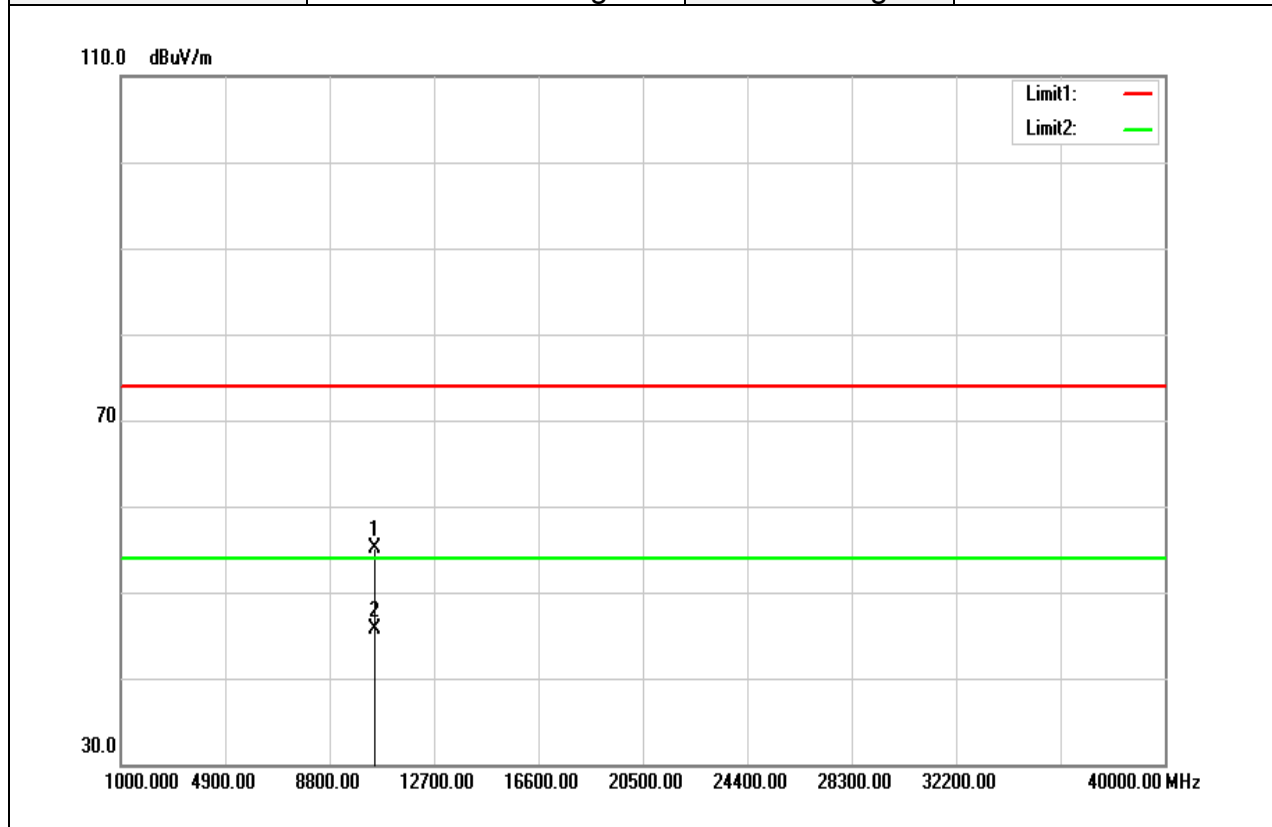

Frequency (MHz)	Reading (dBuV)	Correct Factor (dB/m)	Result (dBuV/m)	Limit (dBuV/m)	Margin (dB)	Remark
10480.000	40.25	14.84	55.09	74.00	-18.91	peak
10480.000	30.91	14.84	45.75	54.00	-8.25	AVG
N/A						

Remark:

1. Measuring frequencies from 1 GHz to the 10th harmonic of highest fundamental frequency.
2. For above 1GHz, the EUT peak value was under average limit, therefore the Average value compliance with the average limit

Test Mode	IEEE 802.11a / 5240MHZ	Temp/Hum	24(°C)/ 33%RH
Test Item	Harmonic	Test Date	November 30, 2017
Polarize	Horizontal	Test Engineer	Jerry Chuang
Detector	Peak and Average	Test Voltage	120Vac / 60Hz

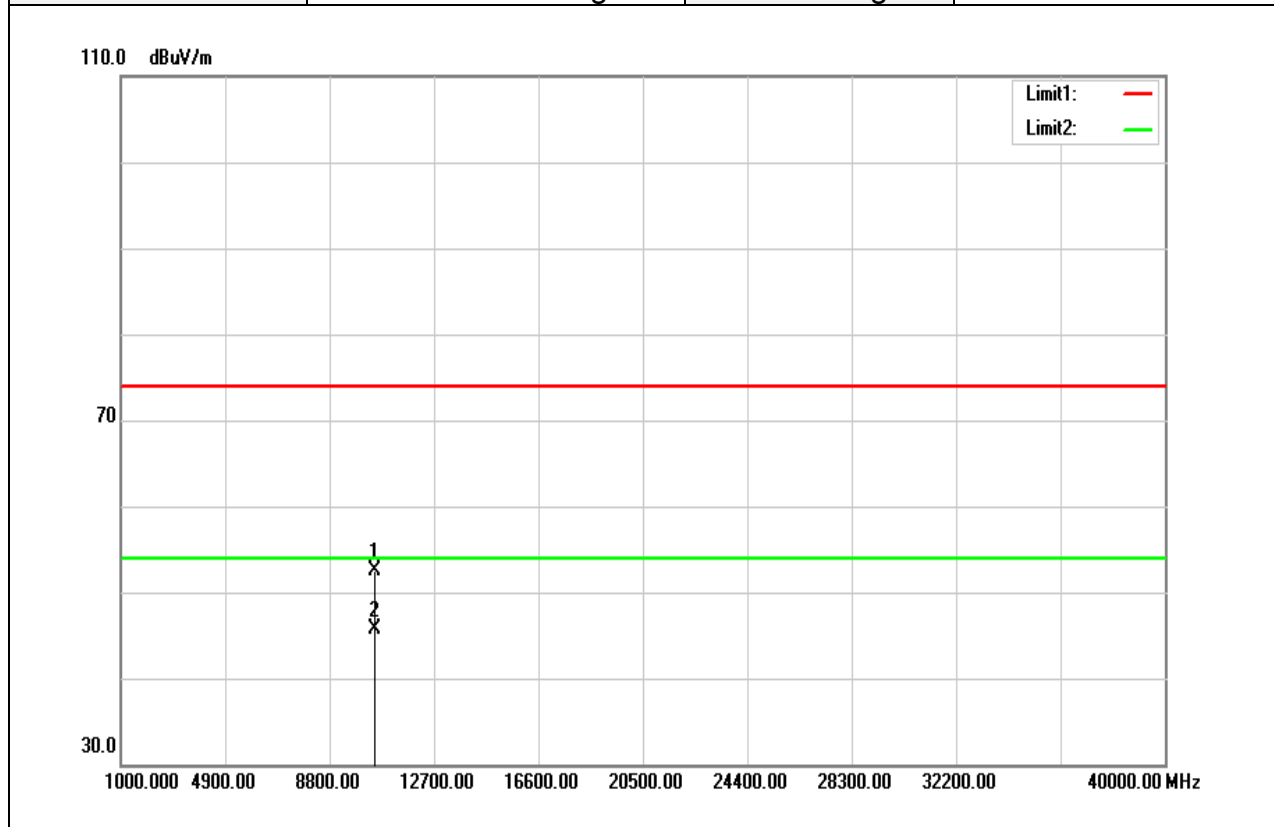

Frequency (MHz)	Reading (dBuV)	Correct Factor (dB/m)	Result (dBuV/m)	Limit (dBuV/m)	Margin (dB)	Remark
10480.000	37.64	14.84	52.48	74.00	-21.52	peak
10480.000	30.84	14.84	45.68	54.00	-8.32	AVG
N/A						

Remark:

1. Measuring frequencies from 1 GHz to the 10th harmonic of highest fundamental frequency.
2. For above 1GHz, the EUT peak value was under average limit, therefore the Average value compliance with the average limit

Test Mode	IEEE 802.11n HT20 / 5180MHZ	Temp/Hum	24(°C)/ 33%RH
Test Item	Harmonic	Test Date	November 30, 2017
Polarize	Vertical	Test Engineer	Jerry Chuang
Detector	Peak and Average	Test Voltage	120Vac / 60Hz

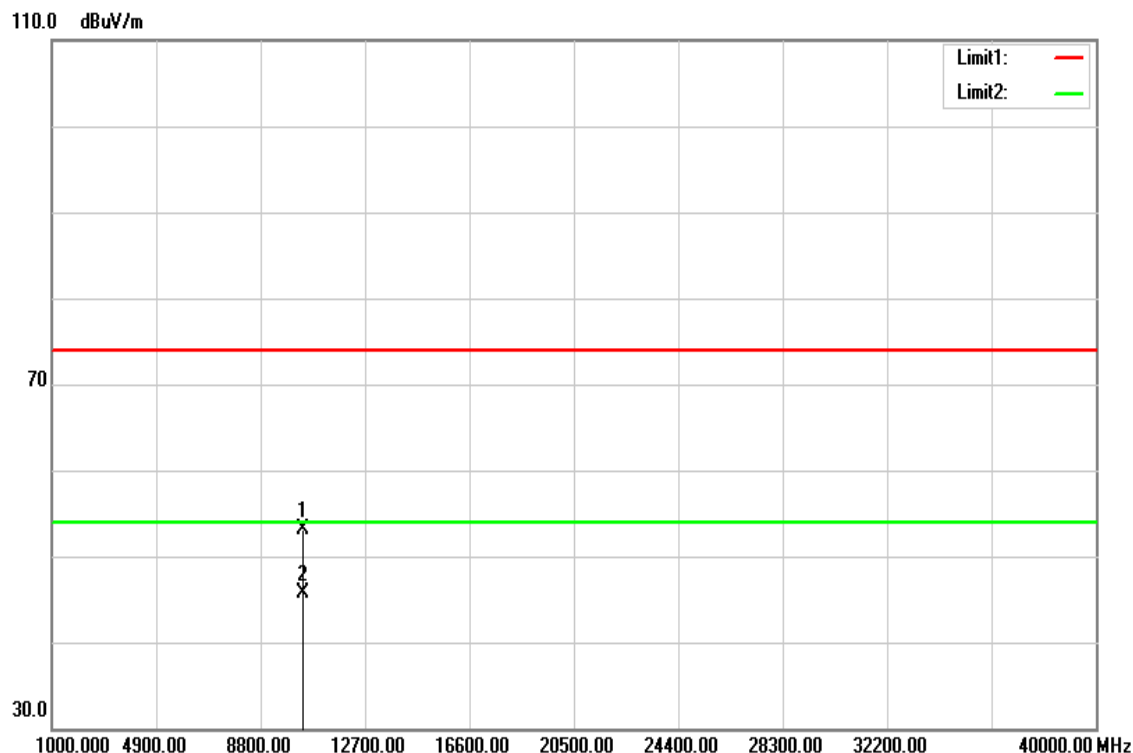

Frequency (MHz)	Reading (dBuV)	Correct Factor (dB/m)	Result (dBuV/m)	Limit (dBuV/m)	Margin (dB)	Remark
10360.000	38.72	14.45	53.17	74.00	-20.83	peak
10360.000	31.19	14.45	45.64	54.00	-8.36	AVG
N/A						

Remark:

1. Measuring frequencies from 1 GHz to the 10th harmonic of highest fundamental frequency.
2. For above 1GHz, the EUT peak value was under average limit, therefore the Average value compliance with the average limit

Test Mode	IEEE 802.11n HT20/ 5180MHZ	Temp/Hum	24(°C)/ 33%RH
Test Item	Harmonic	Test Date	November 30, 2017
Polarize	Horizontal	Test Engineer	Jerry Chuang
Detector	Peak and Average	Test Voltage	120Vac / 60Hz

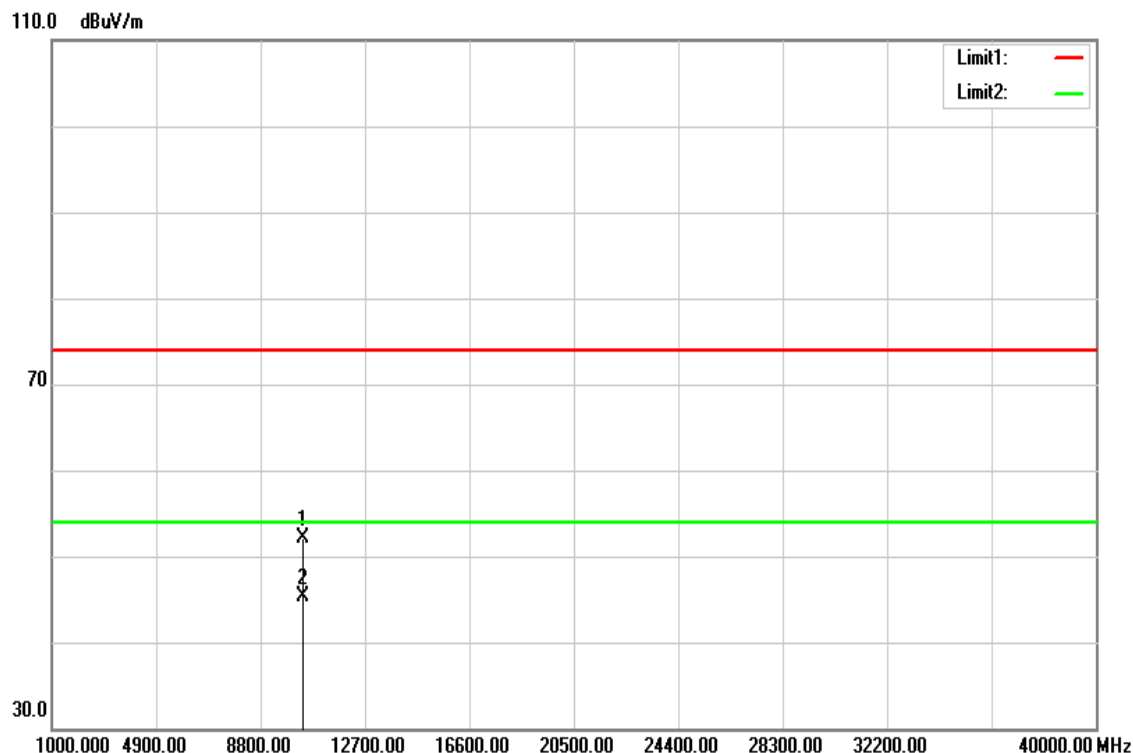

Frequency (MHz)	Reading (dBuV)	Correct Factor (dB/m)	Result (dBuV/m)	Limit (dBuV/m)	Margin (dB)	Remark
10360.000	37.62	14.45	52.07	74.00	-21.93	peak
10360.000	30.79	14.45	45.24	54.00	-8.76	AVG
N/A						

Remark:

1. Measuring frequencies from 1 GHz to the 10th harmonic of highest fundamental frequency.
2. For above 1GHz, the EUT peak value was under average limit, therefore the Average value compliance with the average limit

Test Mode	IEEE 802.11n HT20 / 5220MHZ	Temp/Hum	24(°C)/ 33%RH
Test Item	Harmonic	Test Date	November 30, 2017
Polarize	Vertical	Test Engineer	Jerry Chuang
Detector	Peak and Average	Test Voltage	120Vac / 60Hz

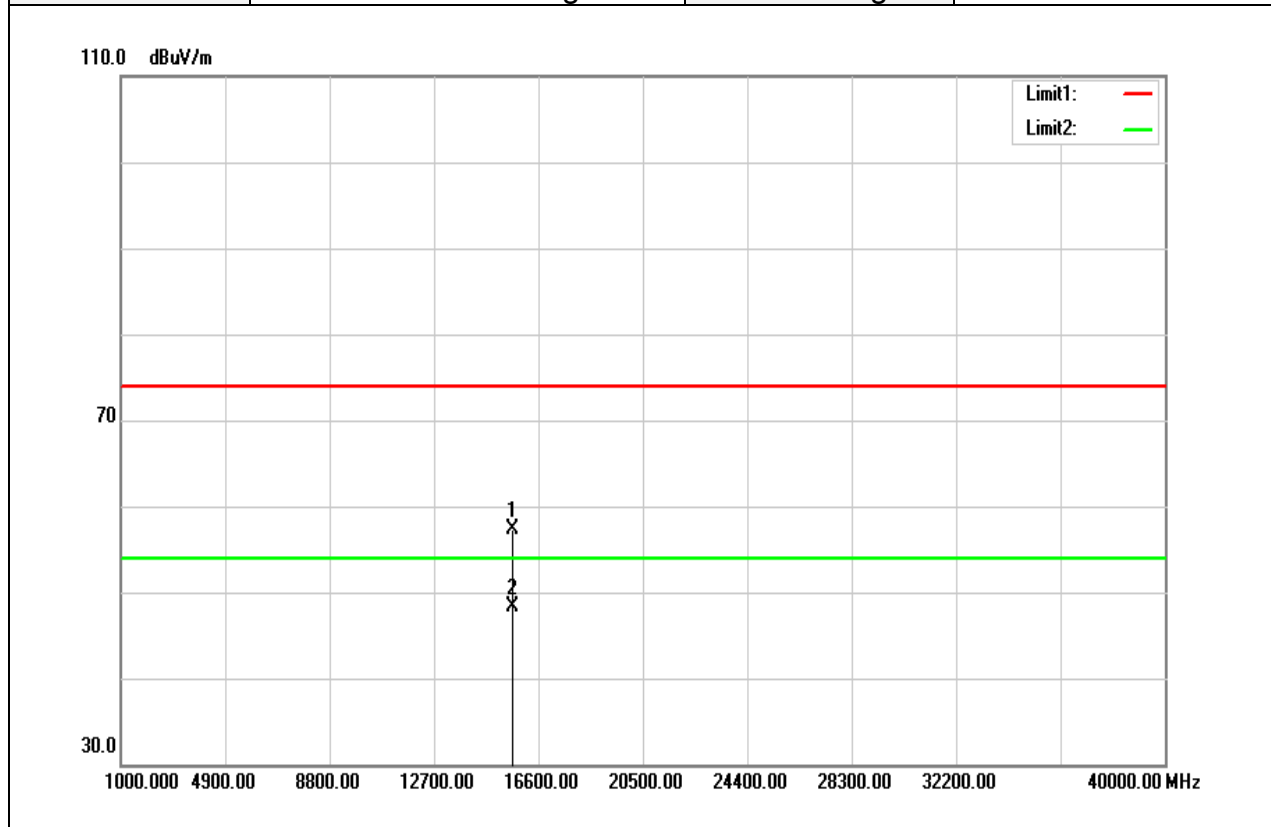

Frequency (MHz)	Reading (dBuV)	Correct Factor (dB/m)	Result (dBuV/m)	Limit (dBuV/m)	Margin (dB)	Remark
15650.000	38.29	19.00	57.29	74.00	-16.71	peak
15650.000	29.34	19.00	48.34	54.00	-5.66	AVG
N/A						

Remark:

1. Measuring frequencies from 1 GHz to the 10th harmonic of highest fundamental frequency.
2. For above 1GHz, the EUT peak value was under average limit, therefore the Average value compliance with the average limit

Test Mode	IEEE 802.11n HT20 / 5220MHZ	Temp/Hum	24(°C)/ 33%RH
Test Item	Harmonic	Test Date	November 30, 2017
Polarize	Horizontal	Test Engineer	Jerry Chuang
Detector	Peak and Average	Test Voltage	120Vac / 60Hz

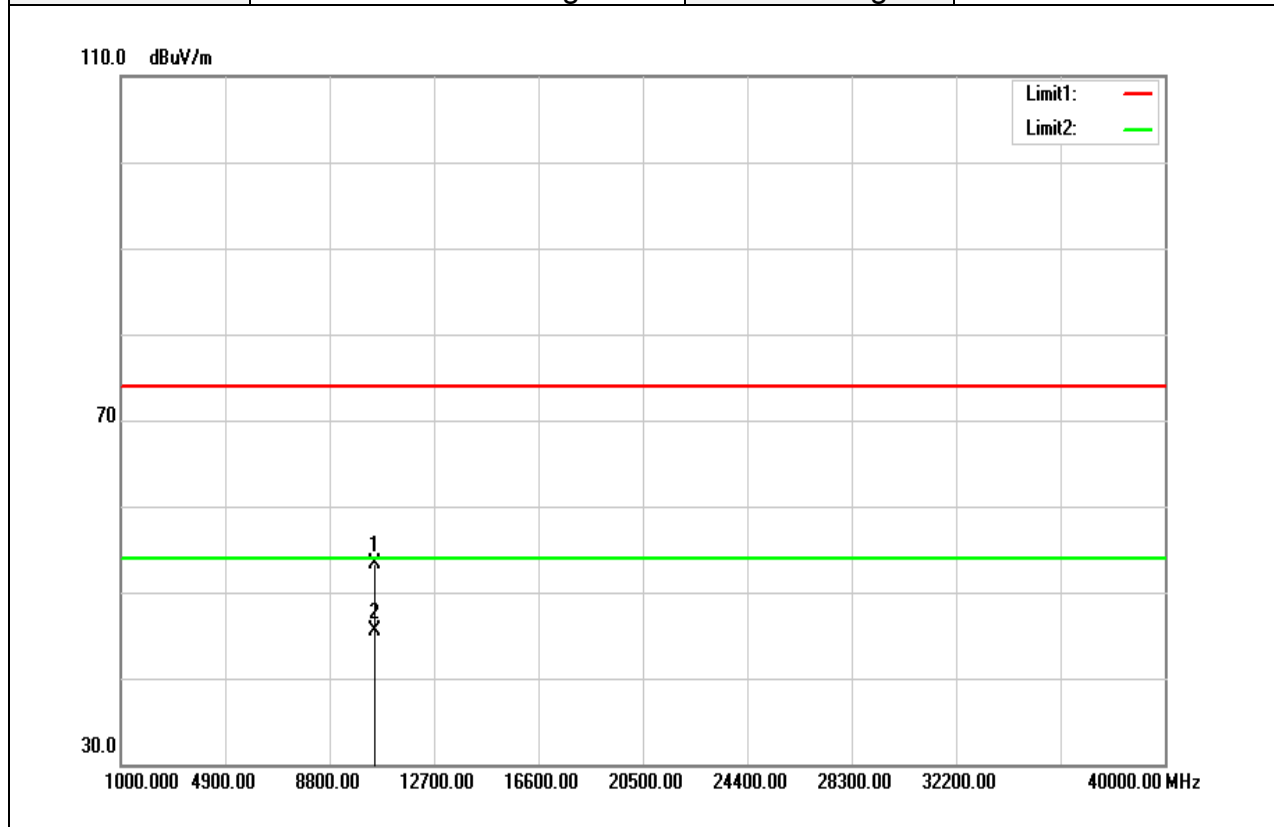

Frequency (MHz)	Reading (dBuV)	Correct Factor (dB/m)	Result (dBuV/m)	Limit (dBuV/m)	Margin (dB)	Remark
10480.000	38.50	14.84	53.34	74.00	-20.66	peak
10480.000	30.61	14.84	45.45	54.00	-8.55	AVG
N/A						

Remark:

1. Measuring frequencies from 1 GHz to the 10th harmonic of highest fundamental frequency.
2. For above 1GHz, the EUT peak value was under average limit, therefore the Average value compliance with the average limit

Test Mode	IEEE 802.11n HT20 / 5240MHZ	Temp/Hum	24(°C)/ 33%RH
Test Item	Harmonic	Test Date	November 30, 2017
Polarize	Vertical	Test Engineer	Jerry Chuang
Detector	Peak and Average	Test Voltage	120Vac / 60Hz

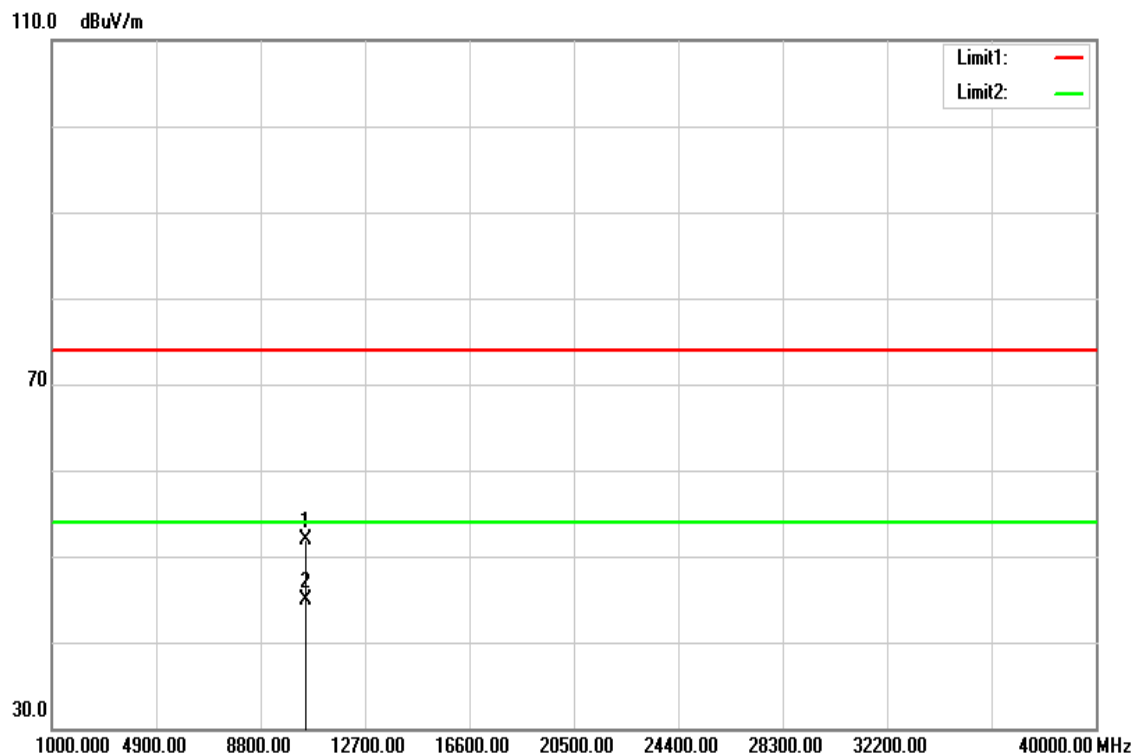

Frequency (MHz)	Reading (dBuV)	Correct Factor (dB/m)	Result (dBuV/m)	Limit (dBuV/m)	Margin (dB)	Remark
10480.000	37.10	14.84	51.94	74.00	-22.06	peak
10480.000	30.13	14.84	44.97	54.00	-9.03	AVG
N/A						

Remark:

1. Measuring frequencies from 1 GHz to the 10th harmonic of highest fundamental frequency.
2. For above 1GHz, the EUT peak value was under average limit, therefore the Average value compliance with the average limit

Test Mode	IEEE 802.11n HT20 / 5240MHZ	Temp/Hum	24(°C)/ 33%RH
Test Item	Harmonic	Test Date	November 30, 2017
Polarize	Horizontal	Test Engineer	Jerry Chuang
Detector	Peak and Average	Test Voltage	120Vac / 60Hz

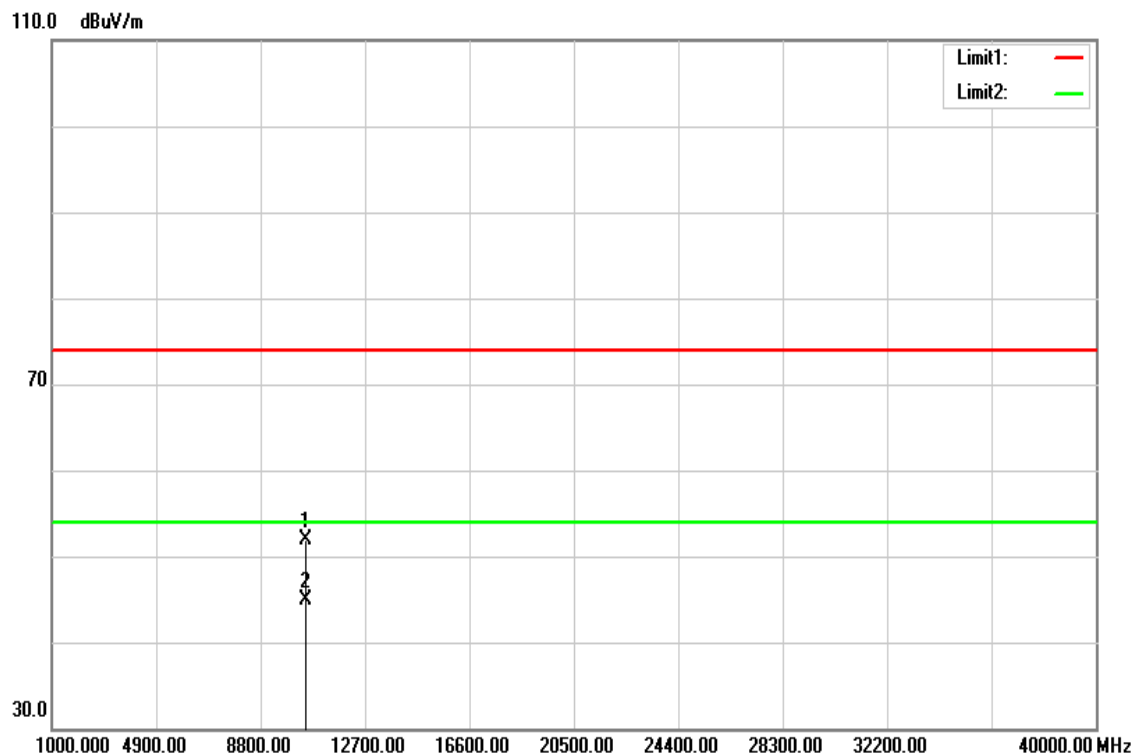

Frequency (MHz)	Reading (dBuV)	Correct Factor (dB/m)	Result (dBuV/m)	Limit (dBuV/m)	Margin (dB)	Remark
10480.000	37.10	14.84	51.94	74.00	-22.06	peak
10480.000	30.13	14.84	44.97	54.00	-9.03	AVG
N/A						

Remark:

1. Measuring frequencies from 1 GHz to the 10th harmonic of highest fundamental frequency.
2. For above 1GHz, the EUT peak value was under average limit, therefore the Average value compliance with the average limit

Test Mode	IEEE 802.11n HT40 / 5190MHZ	Temp/Hum	24(°C)/ 33%RH
Test Item	Harmonic	Test Date	November 30, 2017
Polarize	Vertical	Test Engineer	Jerry Chuang
Detector	Peak and Average	Test Voltage	120Vac / 60Hz

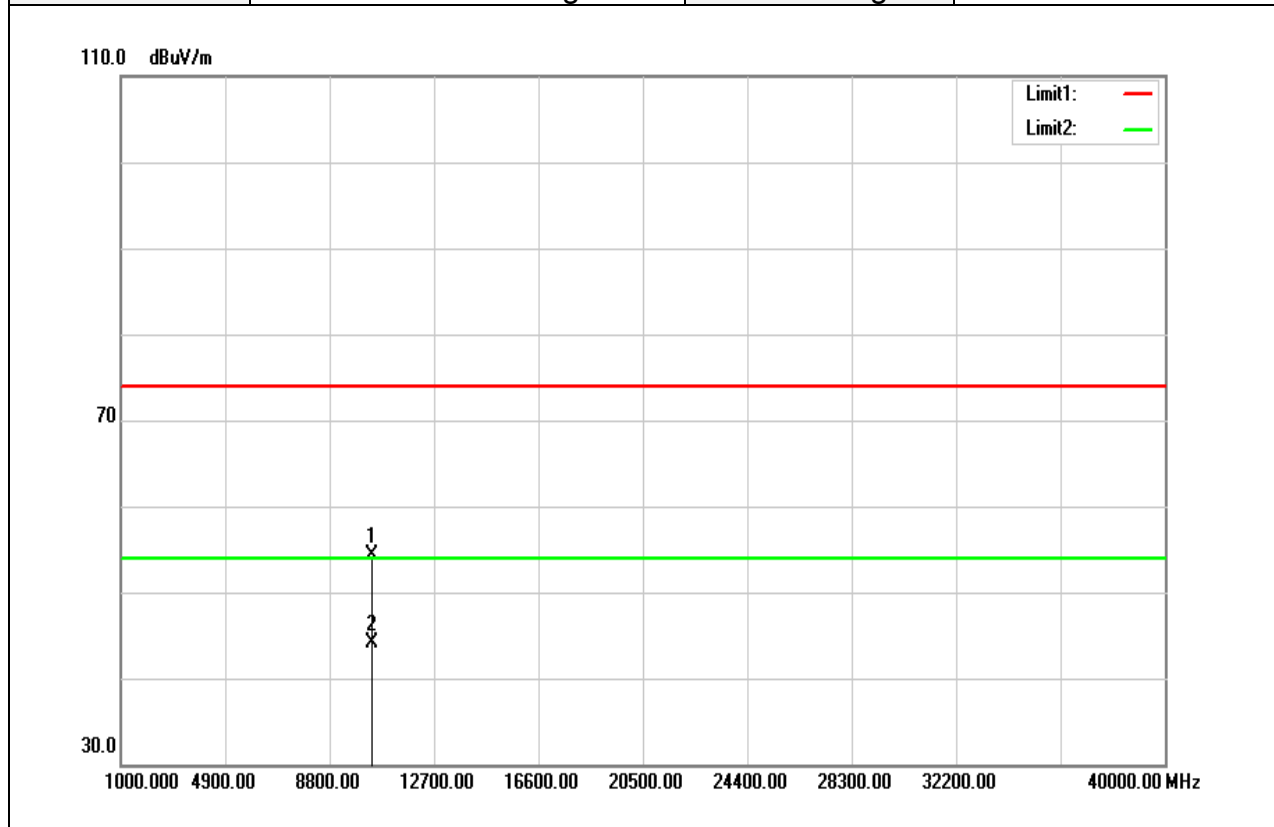

Frequency (MHz)	Reading (dBuV)	Correct Factor (dB/m)	Result (dBuV/m)	Limit (dBuV/m)	Margin (dB)	Remark
10380.000	39.84	14.50	54.34	74.00	-19.66	peak
10380.000	29.56	14.50	44.06	54.00	-9.94	AVG
N/A						

Remark:

1. Measuring frequencies from 1 GHz to the 10th harmonic of highest fundamental frequency.
2. For above 1GHz, the EUT peak value was under average limit, therefore the Average value compliance with the average limit

Test Mode	IEEE 802.11n HT40 / 5190MHZ	Temp/Hum	24(°C)/ 33%RH
Test Item	Harmonic	Test Date	November 30, 2017
Polarize	Horizontal	Test Engineer	Jerry Chuang
Detector	Peak and Average	Test Voltage	120Vac / 60Hz

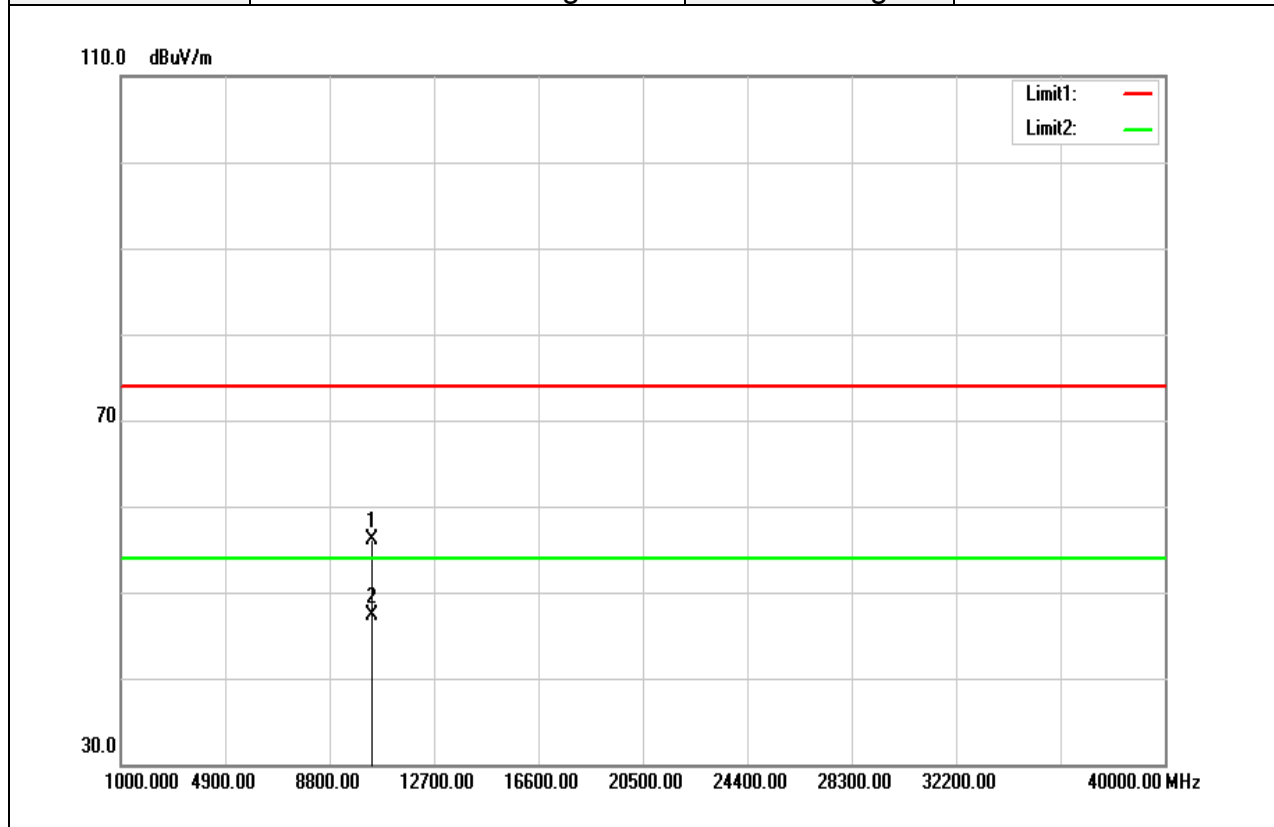

Frequency (MHz)	Reading (dBuV)	Correct Factor (dB/m)	Result (dBuV/m)	Limit (dBuV/m)	Margin (dB)	Remark
10380.000	41.53	14.50	56.03	74.00	-17.97	peak
10380.000	32.73	14.50	47.23	54.00	-6.77	AVG
N/A						

Remark:

1. Measuring frequencies from 1 GHz to the 10th harmonic of highest fundamental frequency.
2. For above 1GHz, the EUT peak value was under average limit, therefore the Average value compliance with the average limit

Test Mode	IEEE 802.11n HT40 / 5230MHZ	Temp/Hum	24(°C)/ 33%RH
Test Item	Harmonic	Test Date	November 30, 2017
Polarize	Vertical	Test Engineer	Jerry Chuang
Detector	Peak and Average	Test Voltage	120Vac / 60Hz

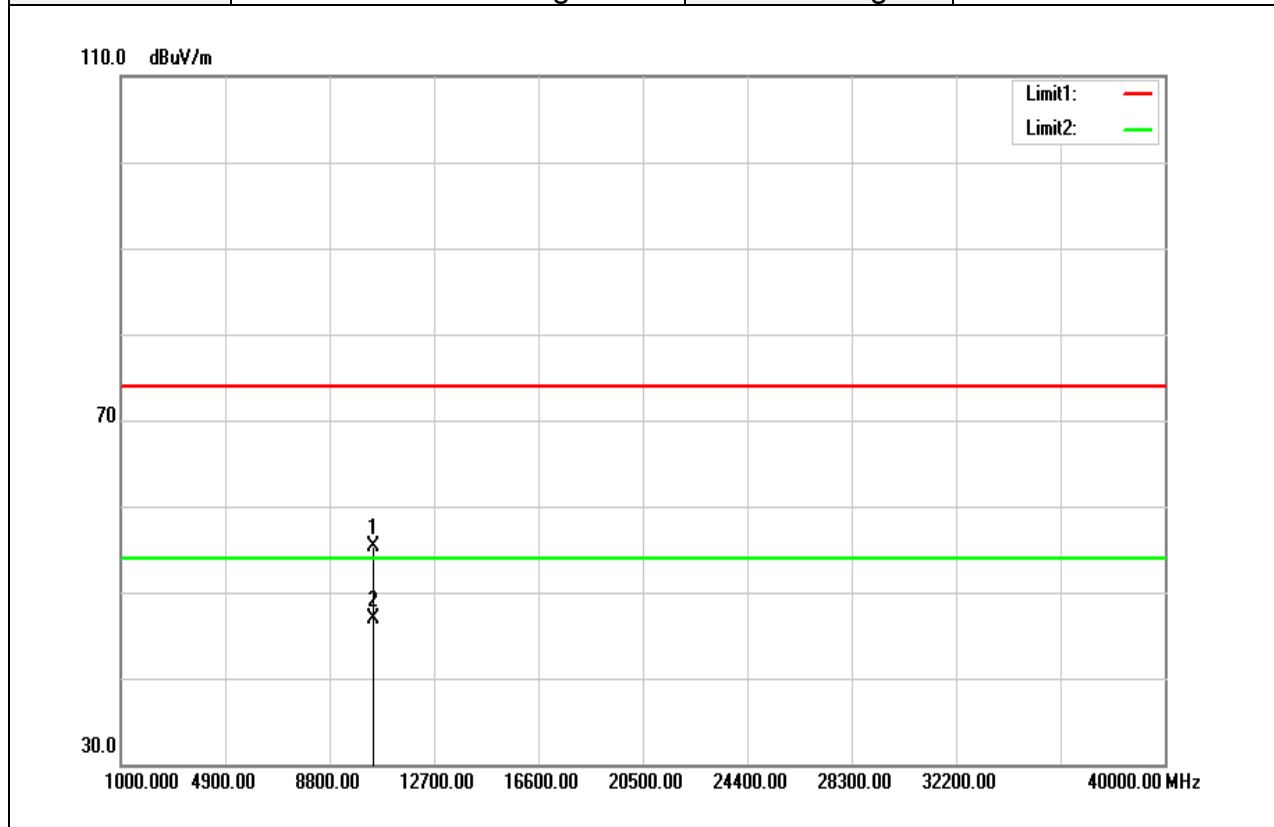

Frequency (MHz)	Reading (dBuV)	Correct Factor (dB/m)	Result (dBuV/m)	Limit (dBuV/m)	Margin (dB)	Remark
10460.000	40.51	14.79	55.30	74.00	-18.70	peak
10460.000	32.09	14.79	46.88	54.00	-7.12	AVG
N/A						

Remark:

1. Measuring frequencies from 1 GHz to the 10th harmonic of highest fundamental frequency.
2. For above 1GHz, the EUT peak value was under average limit, therefore the Average value compliance with the average limit

Test Mode	IEEE 802.11n HT40 / 5230MHZ	Temp/Hum	24(°C)/ 33%RH
Test Item	Harmonic	Test Date	November 30, 2017
Polarize	Horizontal	Test Engineer	Jerry Chuang
Detector	Peak and Average	Test Voltage	120Vac / 60Hz

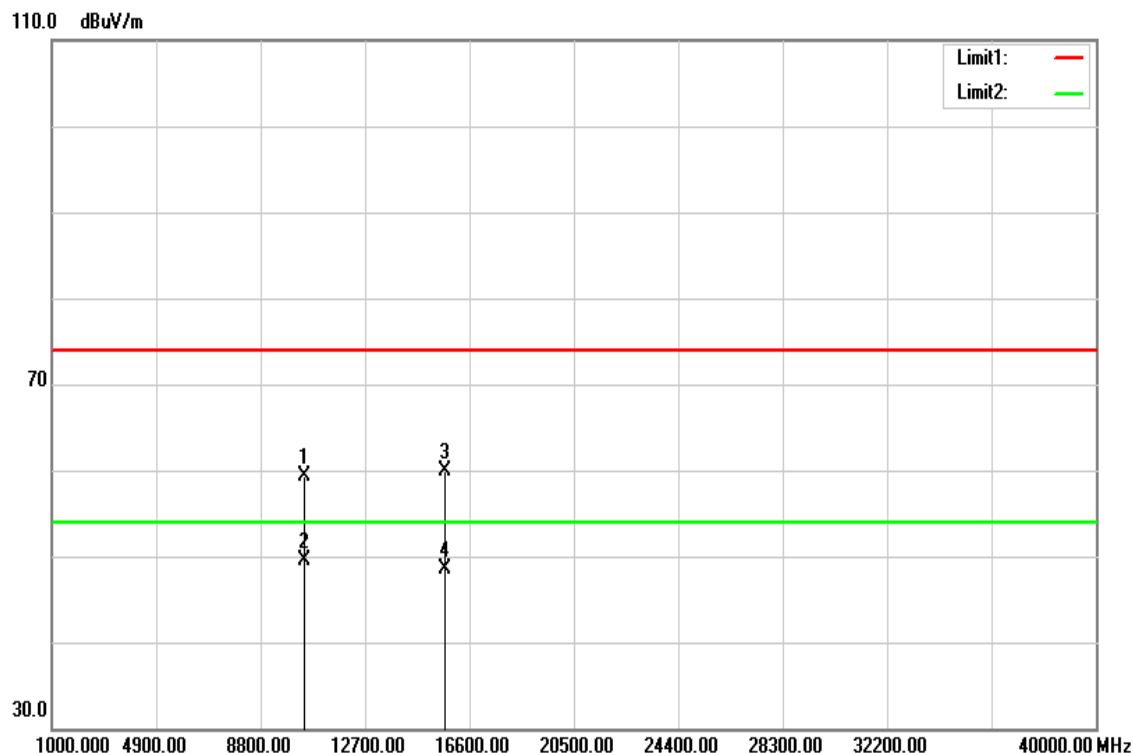

Frequency (MHz)	Reading (dBuV)	Correct Factor (dB/m)	Result (dBuV/m)	Limit (dBuV/m)	Margin (dB)	Remark
10460.000	44.42	14.79	59.21	74.00	-14.79	peak
10460.000	34.69	14.79	49.48	54.00	-4.52	AVG
15690.000	40.69	19.12	59.81	74.00	-14.19	peak
15690.000	29.32	19.12	48.44	54.00	-5.56	AVG
N/A						

Remark:

1. Measuring frequencies from 1 GHz to the 10th harmonic of highest fundamental frequency.
2. For above 1GHz, the EUT peak value was under average limit, therefore the Average value compliance with the average limit

Test Mode	IEEE 802.11ac VHT80 / 5210MHZ	Temp/Hum	24(°C)/ 33%RH
Test Item	Harmonic	Test Date	November 30, 2017
Polarize	Vertical	Test Engineer	Jerry Chuang
Detector	Peak and Average	Test Voltage	120Vac / 60Hz

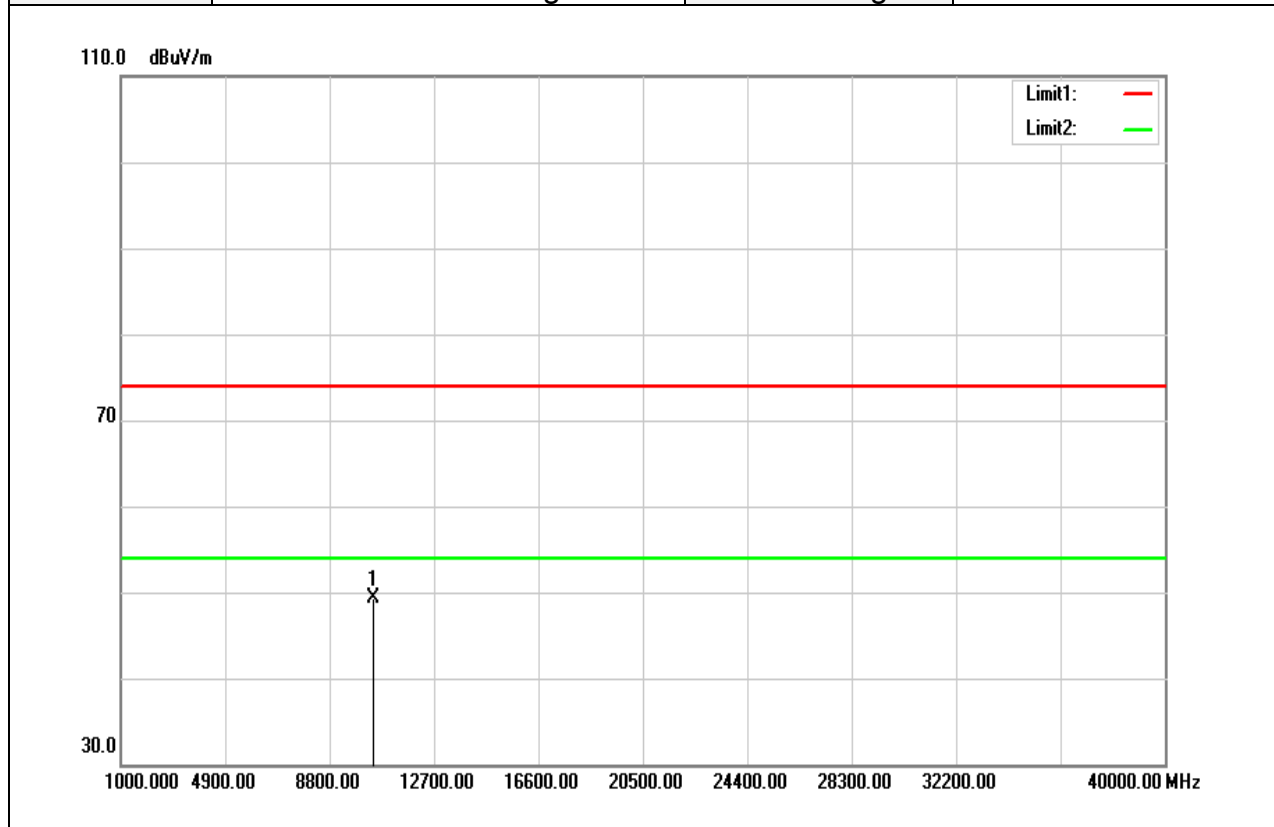

Frequency (MHz)	Reading (dBuV)	Correct Factor (dB/m)	Result (dBuV/m)	Limit (dBuV/m)	Margin (dB)	Remark
10420.000	34.72	14.66	49.38	74.00	-24.62	peak
N/A						

Remark:

1. Measuring frequencies from 1 GHz to the 10th harmonic of highest fundamental frequency.
2. For above 1GHz, the EUT peak value was under average limit, therefore the Average value compliance with the average limit

Test Mode	IEEE 802.11ac VHT80 / 5210MHZ	Temp/Hum	24(°C)/ 33%RH
Test Item	Harmonic	Test Date	November 30, 2017
Polarize	Horizontal	Test Engineer	Jerry Chuang
Detector	Peak and Average	Test Voltage	120Vac / 60Hz

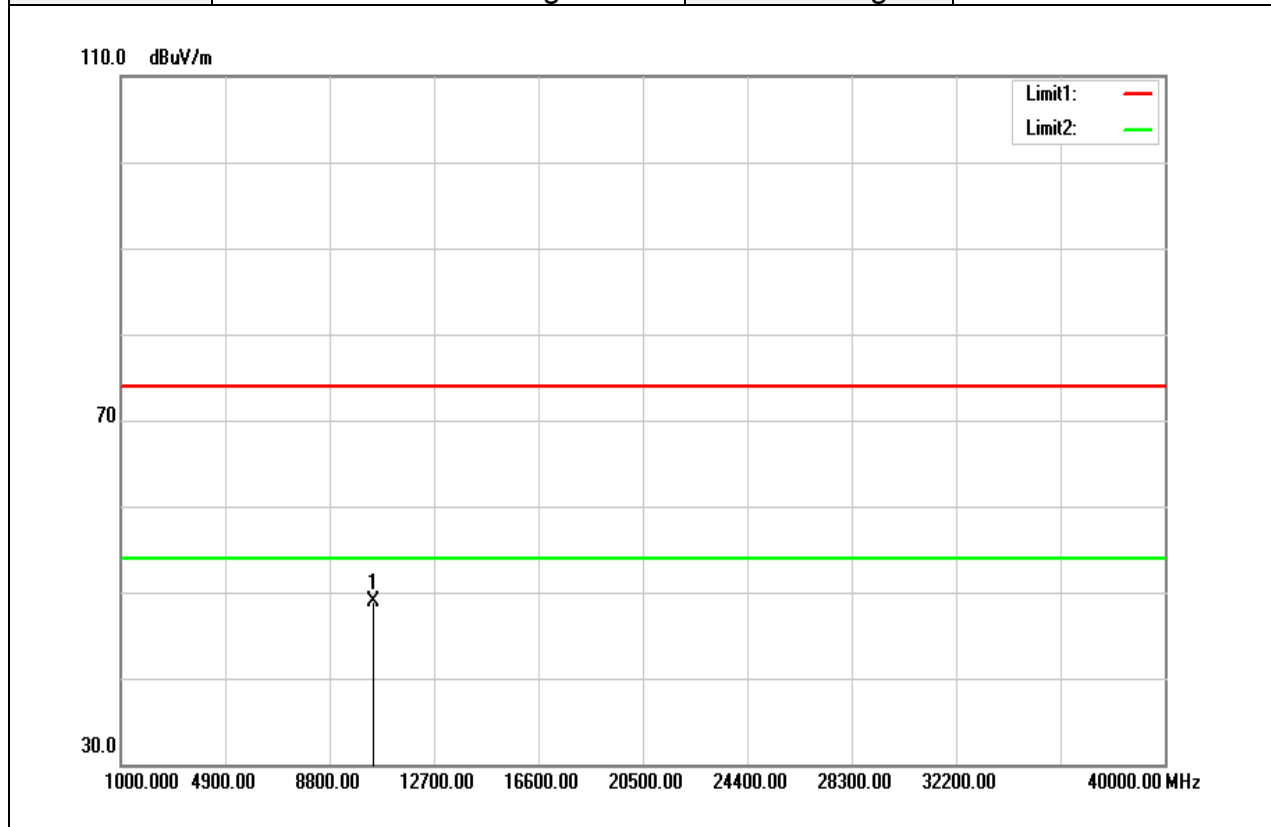

Frequency (MHz)	Reading (dBuV)	Correct Factor (dB/m)	Result (dBuV/m)	Limit (dBuV/m)	Margin (dB)	Remark
10420.000	34.25	14.66	48.91	74.00	-25.09	peak
N/A						

Remark:

1. Measuring frequencies from 1 GHz to the 10th harmonic of highest fundamental frequency.
2. For above 1GHz, the EUT peak value was under average limit, therefore the Average value compliance with the average limit

Above 1G Test Data for UNII-2a

Test Mode	IEEE 802.11a / 5260 MHz	Temp/Hum	24(°C)/ 33%RH
Test Item	Harmonic	Test Date	November 30, 2017
Polarize	Vertical	Test Engineer	Jerry Chuang
Detector	Peak and Average	Test Voltage	120Vac / 60Hz

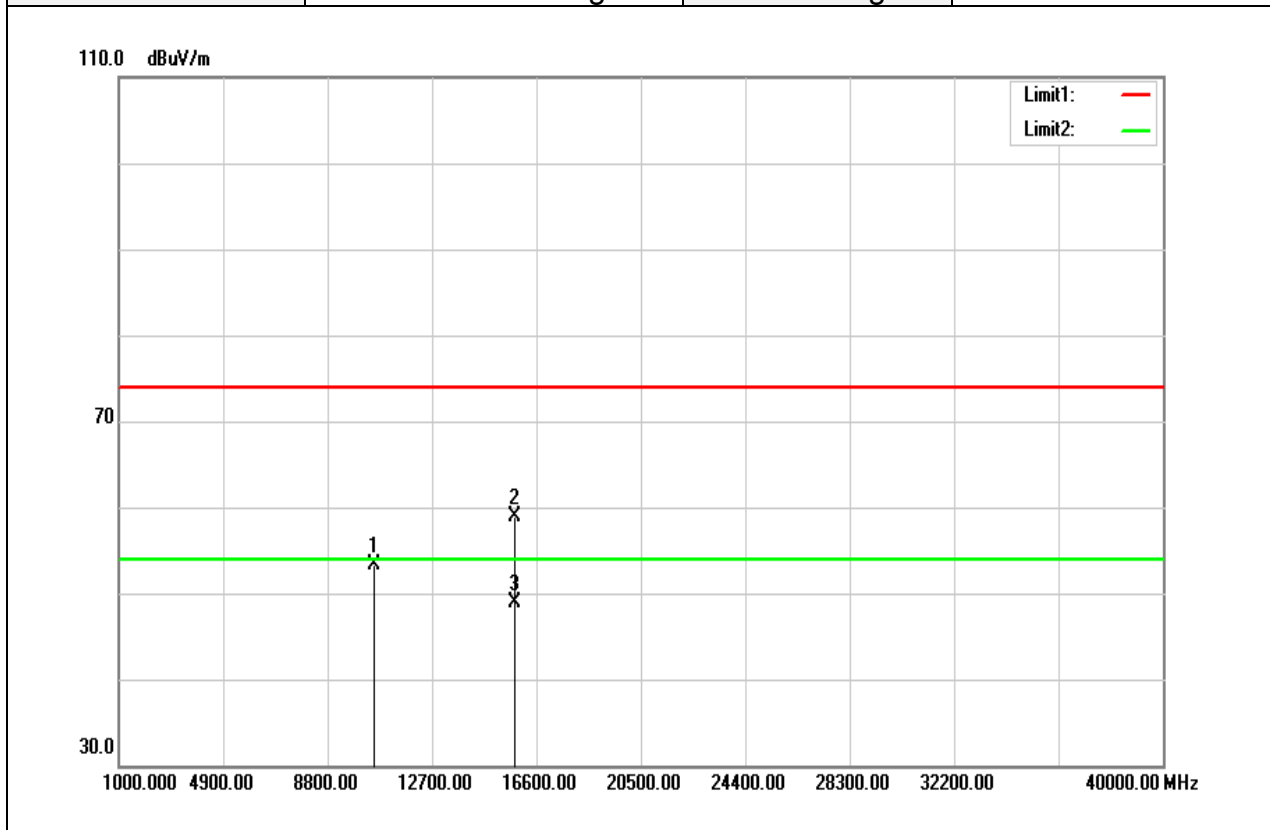

Frequency (MHz)	Reading (dBuV)	Correct Factor (dB/m)	Result (dBuV/m)	Limit (dBuV/m)	Margin (dB)	Remark
10520.000	38.40	14.97	53.37	74.00	-20.63	peak
15780.000	39.43	19.38	58.81	74.00	-15.19	peak
15780.000	29.44	19.38	48.82	54.00	-5.18	AVG
N/A						

Remark:

1. Measuring frequencies from 1 GHz to the 10th harmonic of highest fundamental frequency.
2. For above 1GHz, the EUT peak value was under average limit, therefore the Average value compliance with the average limit

Test Mode	IEEE 802.11a / 5260 MHz	Temp/Hum	24(°C)/ 33%RH
Test Item	Harmonic	Test Date	November 30, 2017
Polarize	Horizontal	Test Engineer	Jerry Chuang
Detector	Peak and Average	Test Voltage	120Vac / 60Hz

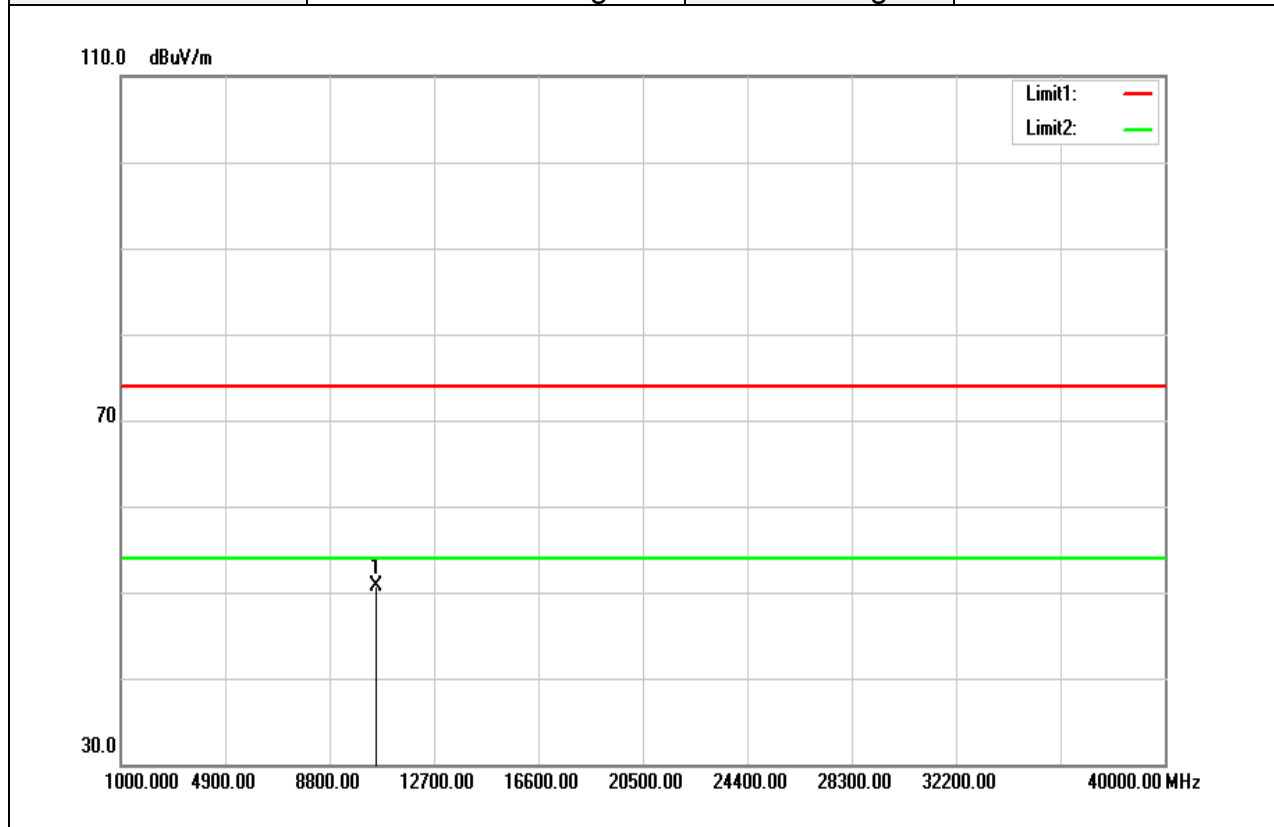

Frequency (MHz)	Reading (dBuV)	Correct Factor (dB/m)	Result (dBuV/m)	Limit (dBuV/m)	Margin (dB)	Remark
10520.000	35.83	14.97	50.80	74.00	-23.20	peak
N/A						

Remark:

1. Measuring frequencies from 1 GHz to the 10th harmonic of highest fundamental frequency.
2. For above 1GHz, the EUT peak value was under average limit, therefore the Average value compliance with the average limit

Test Mode	IEEE 802.11a / 5280 MHz	Temp/Hum	24(°C)/ 33%RH
Test Item	Harmonic	Test Date	November 30, 2017
Polarize	Vertical	Test Engineer	Jerry Chuang
Detector	Peak and Average	Test Voltage	120Vac / 60Hz

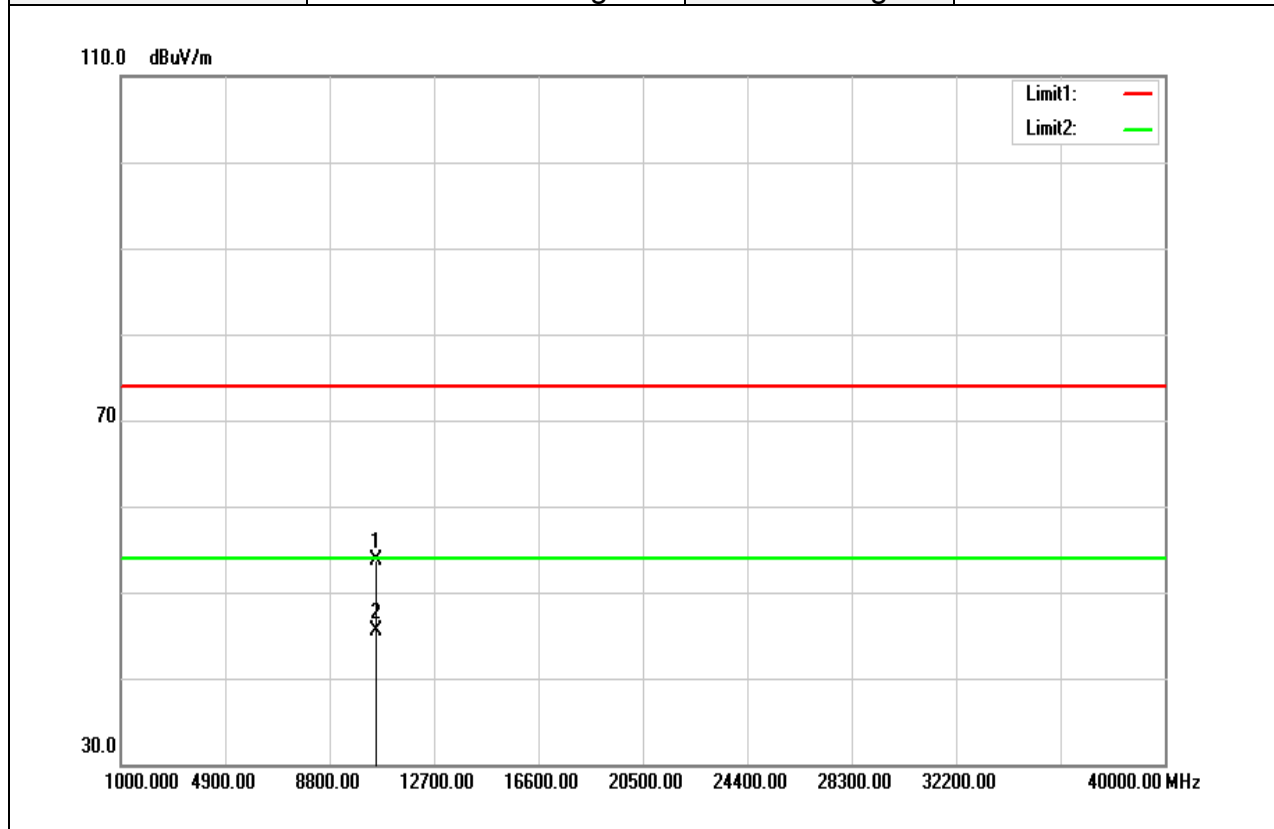

Frequency (MHz)	Reading (dBuV)	Correct Factor (dB/m)	Result (dBuV/m)	Limit (dBuV/m)	Margin (dB)	Remark
10560.000	38.57	15.06	53.63	74.00	-20.37	peak
10560.000	30.54	15.06	45.60	54.00	-8.40	AVG
N/A						

Remark:

1. Measuring frequencies from 1 GHz to the 10th harmonic of highest fundamental frequency.
2. For above 1GHz, the EUT peak value was under average limit, therefore the Average value compliance with the average limit

Test Mode	IEEE 802.11a / 5280 MHz	Temp/Hum	24(°C)/ 33%RH
Test Item	Harmonic	Test Date	November 30, 2017
Polarize	Horizontal	Test Engineer	Jerry Chuang
Detector	Peak and Average	Test Voltage	120Vac / 60Hz

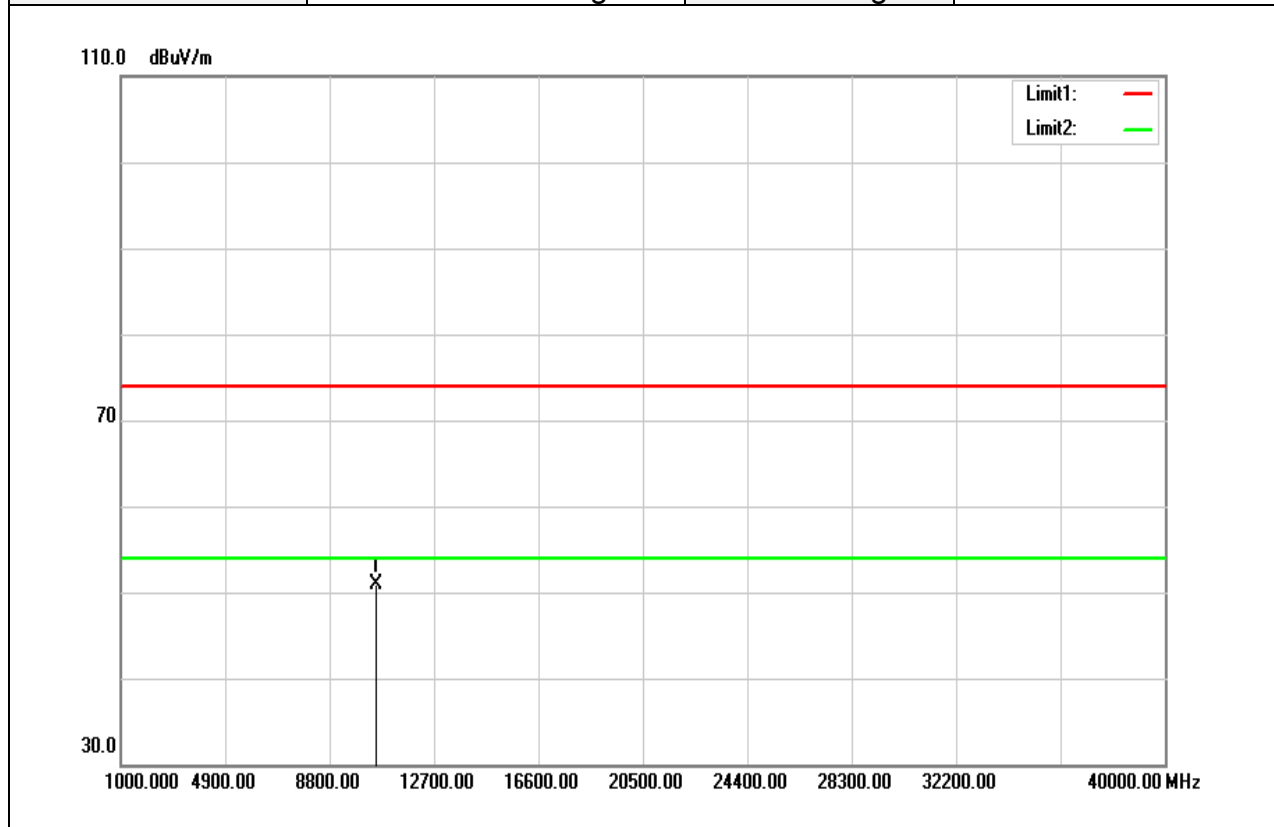

Frequency (MHz)	Reading (dBuV)	Correct Factor (dB/m)	Result (dBuV/m)	Limit (dBuV/m)	Margin (dB)	Remark
10560.000	35.88	15.06	50.94	74.00	-23.06	peak
N/A						

Remark:

1. Measuring frequencies from 1 GHz to the 10th harmonic of highest fundamental frequency.
2. For above 1GHz, the EUT peak value was under average limit, therefore the Average value compliance with the average limit

Test Mode	IEEE 802.11a / 5320 MHz	Temp/Hum	24(°C)/ 33%RH
Test Item	Harmonic	Test Date	November 30, 2017
Polarize	Vertical	Test Engineer	Jerry Chuang
Detector	Peak and Average	Test Voltage	120Vac / 60Hz

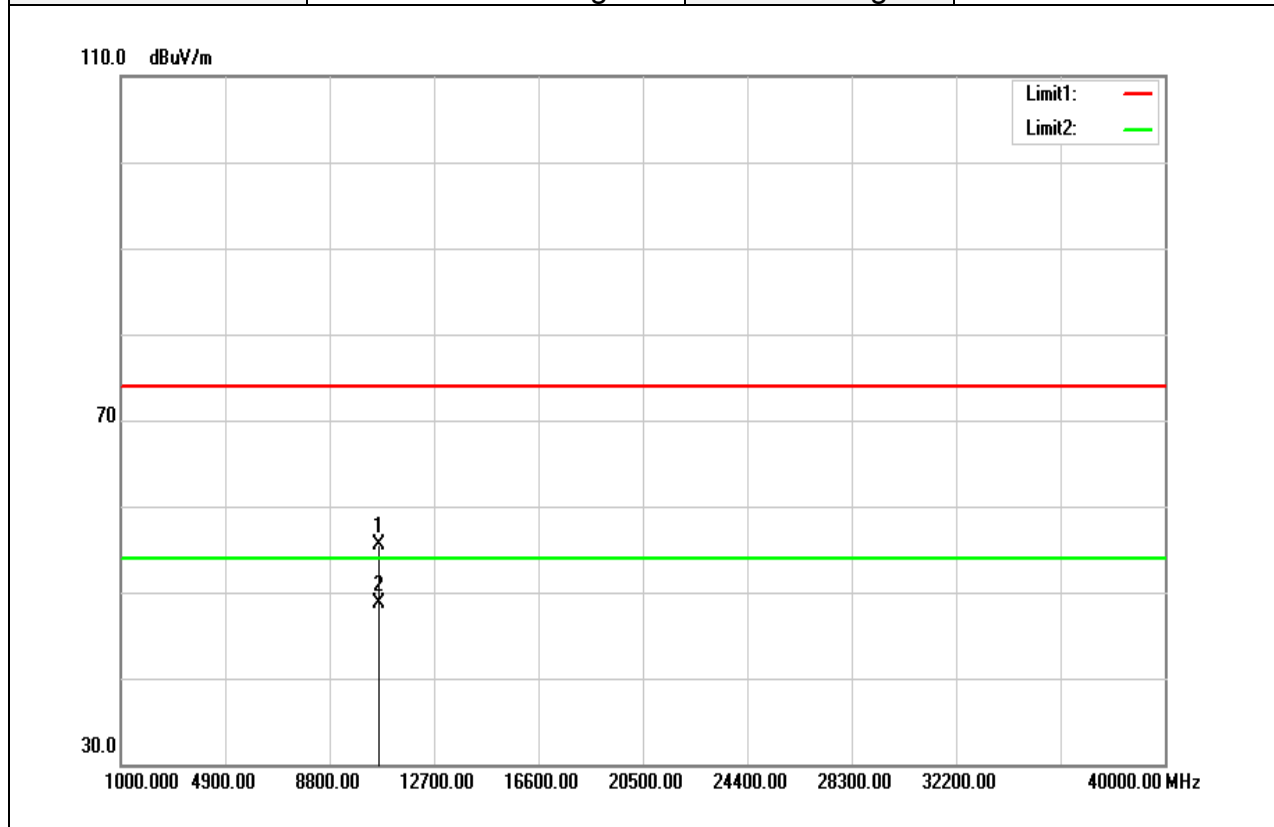

Frequency (MHz)	Reading (dBuV)	Correct Factor (dB/m)	Result (dBuV/m)	Limit (dBuV/m)	Margin (dB)	Remark
10640.000	40.28	15.23	55.51	74.00	-18.49	peak
10640.000	33.44	15.23	48.67	54.00	-5.33	AVG
N/A						

Remark:

1. Measuring frequencies from 1 GHz to the 10th harmonic of highest fundamental frequency.
2. For above 1GHz, the EUT peak value was under average limit, therefore the Average value compliance with the average limit

Test Mode	IEEE 802.11a / 5320 MHz	Temp/Hum	24(°C)/ 33%RH
Test Item	Harmonic	Test Date	November 30, 2017
Polarize	Horizontal	Test Engineer	Jerry Chuang
Detector	Peak and Average	Test Voltage	120Vac / 60Hz

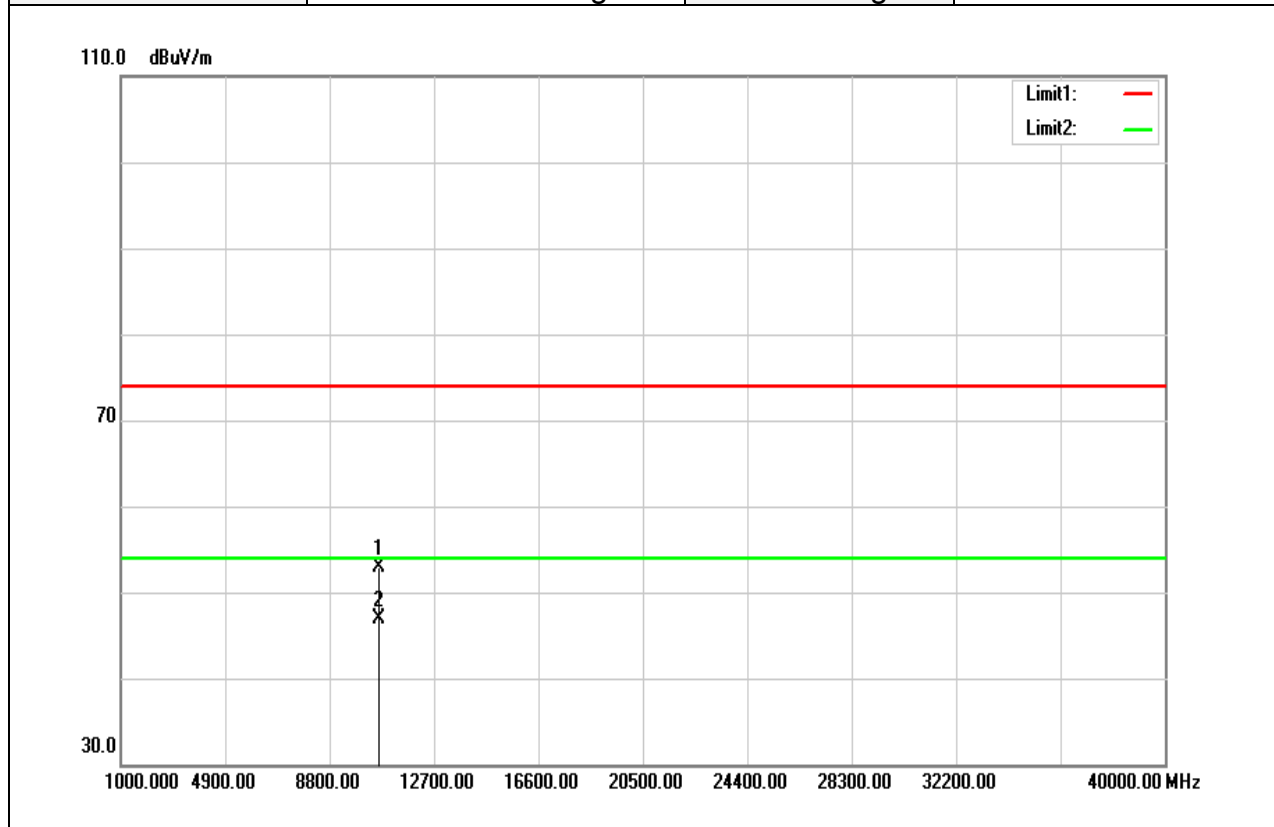

Frequency (MHz)	Reading (dBuV)	Correct Factor (dB/m)	Result (dBuV/m)	Limit (dBuV/m)	Margin (dB)	Remark
10640.000	37.60	15.23	52.83	74.00	-21.17	peak
10640.000	31.75	15.23	46.98	54.00	-7.02	AVG
N/A						

Remark:

1. Measuring frequencies from 1 GHz to the 10th harmonic of highest fundamental frequency.
2. For above 1GHz, the EUT peak value was under average limit, therefore the Average value compliance with the average limit

Test Mode	IEEE 802.11n HT20 / 5260 MHz	Temp/Hum	24(°C)/ 33%RH
Test Item	Harmonic	Test Date	November 30, 2017
Polarize	Vertical	Test Engineer	Jerry Chuang
Detector	Peak and Average	Test Voltage	120Vac / 60Hz

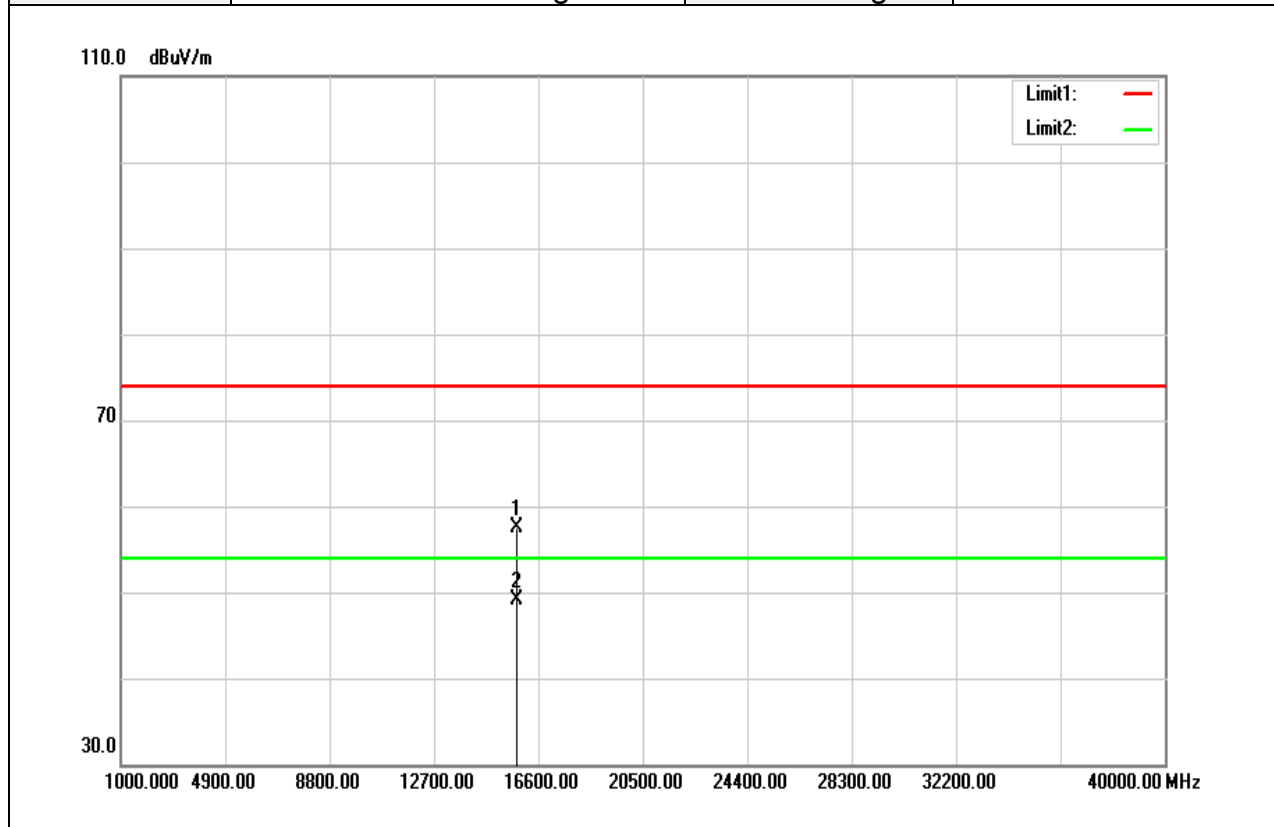

Frequency (MHz)	Reading (dBuV)	Correct Factor (dB/m)	Result (dBuV/m)	Limit (dBuV/m)	Margin (dB)	Remark
15770.000	38.12	19.35	57.47	74.00	-16.53	peak
15770.000	29.77	19.35	49.12	54.00	-4.88	AVG
N/A						

Remark:

1. Measuring frequencies from 1 GHz to the 10th harmonic of highest fundamental frequency.
2. For above 1GHz, the EUT peak value was under average limit, therefore the Average value compliance with the average limit

Test Mode	IEEE 802.11n HT20 / 5260 MHz	Temp/Hum	24(°C)/ 33%RH
Test Item	Harmonic	Test Date	November 30, 2017
Polarize	Horizontal	Test Engineer	Jerry Chuang
Detector	Peak and Average	Test Voltage	120Vac / 60Hz

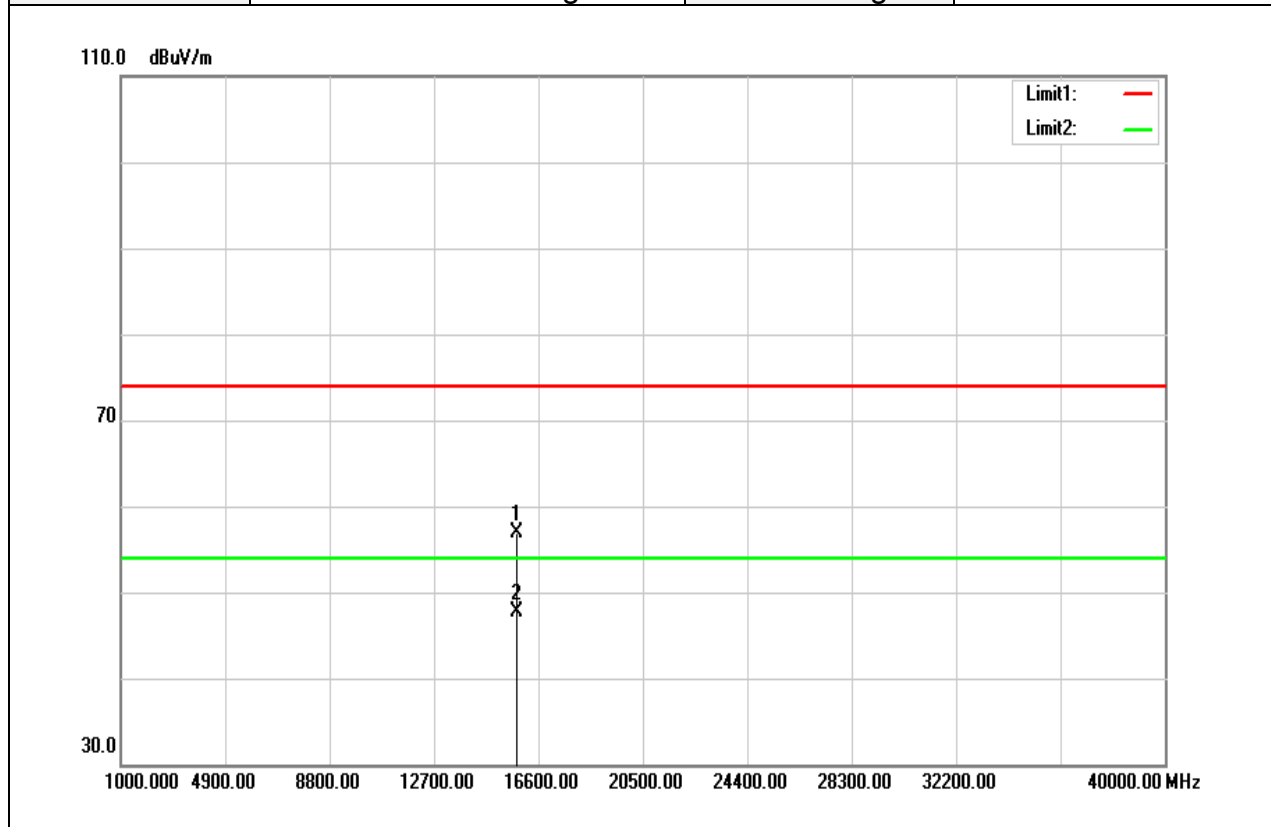

Frequency (MHz)	Reading (dBuV)	Correct Factor (dB/m)	Result (dBuV/m)	Limit (dBuV/m)	Margin (dB)	Remark
15770.000	37.48	19.35	56.83	74.00	-17.17	peak
15770.000	28.28	19.35	47.63	54.00	-6.37	AVG
N/A						

Remark:

1. Measuring frequencies from 1 GHz to the 10th harmonic of highest fundamental frequency.
2. For above 1GHz, the EUT peak value was under average limit, therefore the Average value compliance with the average limit

Test Mode	IEEE 802.11n HT20 / 5280 MHz	Temp/Hum	24(°C)/ 33%RH
Test Item	Harmonic	Test Date	November 30, 2017
Polarize	Vertical	Test Engineer	Jerry Chuang
Detector	Peak and Average	Test Voltage	120Vac / 60Hz

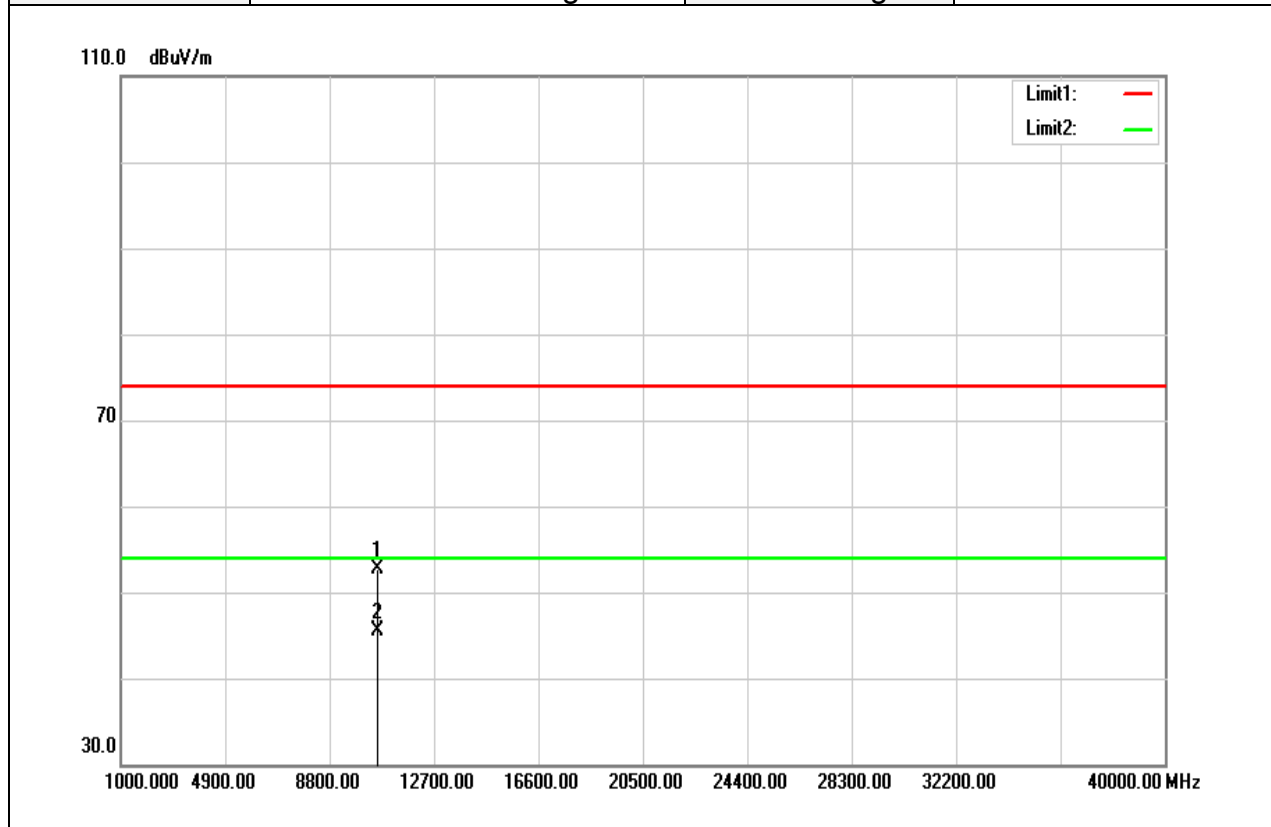

Frequency (MHz)	Reading (dBuV)	Correct Factor (dB/m)	Result (dBuV/m)	Limit (dBuV/m)	Margin (dB)	Remark
10570.000	37.68	15.09	52.77	74.00	-21.23	peak
10570.000	30.45	15.09	45.54	74.00	-28.46	peak
N/A						

Remark:

1. Measuring frequencies from 1 GHz to the 10th harmonic of highest fundamental frequency.
2. For above 1GHz, the EUT peak value was under average limit, therefore the Average value compliance with the average limit

Test Mode	IEEE 802.11n HT20 / 5280 MHz	Temp/Hum	24(°C)/ 33%RH
Test Item	Harmonic	Test Date	November 30, 2017
Polarize	Horizontal	Test Engineer	Jerry Chuang
Detector	Peak and Average	Test Voltage	120Vac / 60Hz

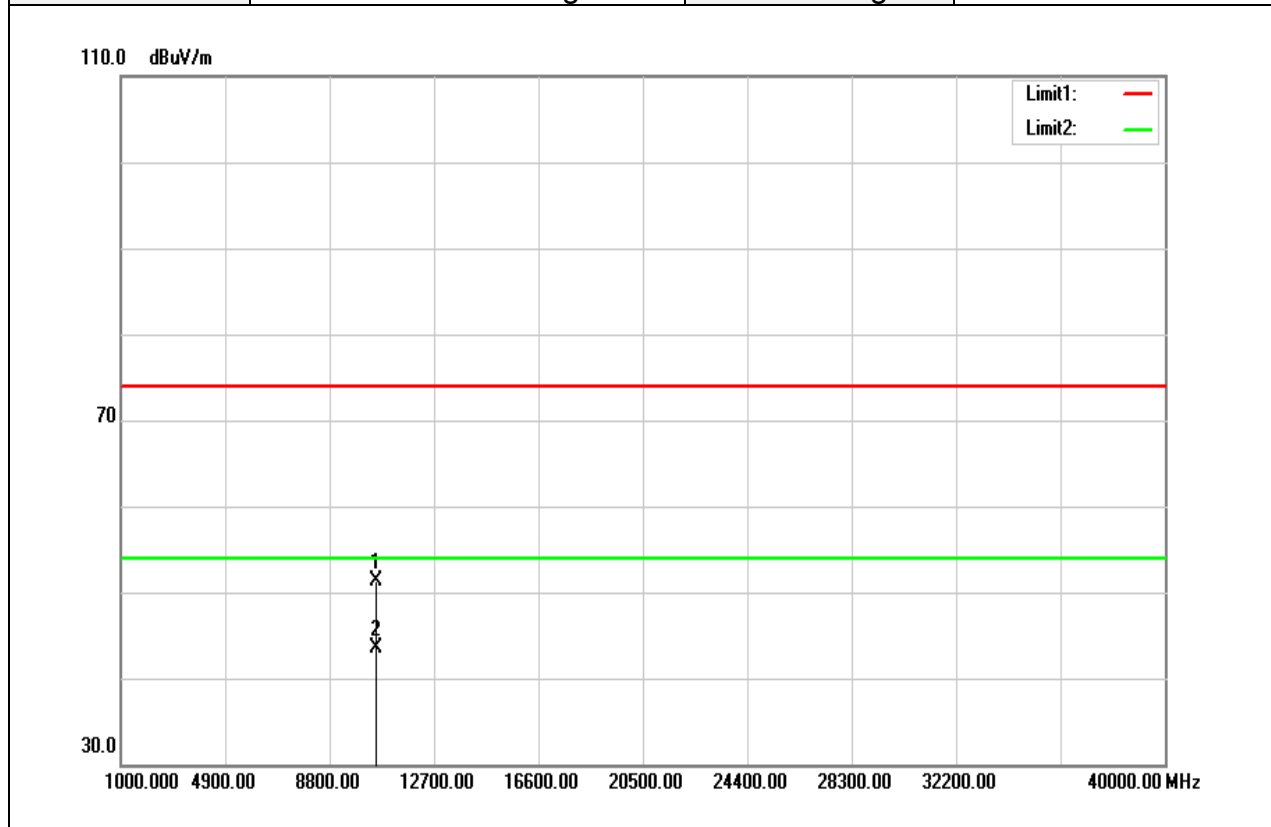

Frequency (MHz)	Reading (dBuV)	Correct Factor (dB/m)	Result (dBuV/m)	Limit (dBuV/m)	Margin (dB)	Remark
10560.000	36.34	15.06	51.40	74.00	-22.60	peak
10560.000	28.43	15.06	43.49	54.00	-10.51	AVG
N/A						

Remark:

1. Measuring frequencies from 1 GHz to the 10th harmonic of highest fundamental frequency.
2. For above 1GHz, the EUT peak value was under average limit, therefore the Average value compliance with the average limit

Test Mode	IEEE 802.11n HT20 / 5320 MHz	Temp/Hum	24(°C)/ 33%RH
Test Item	Harmonic	Test Date	November 30, 2017
Polarize	Vertical	Test Engineer	Jerry Chuang
Detector	Peak and Average	Test Voltage	120Vac / 60Hz

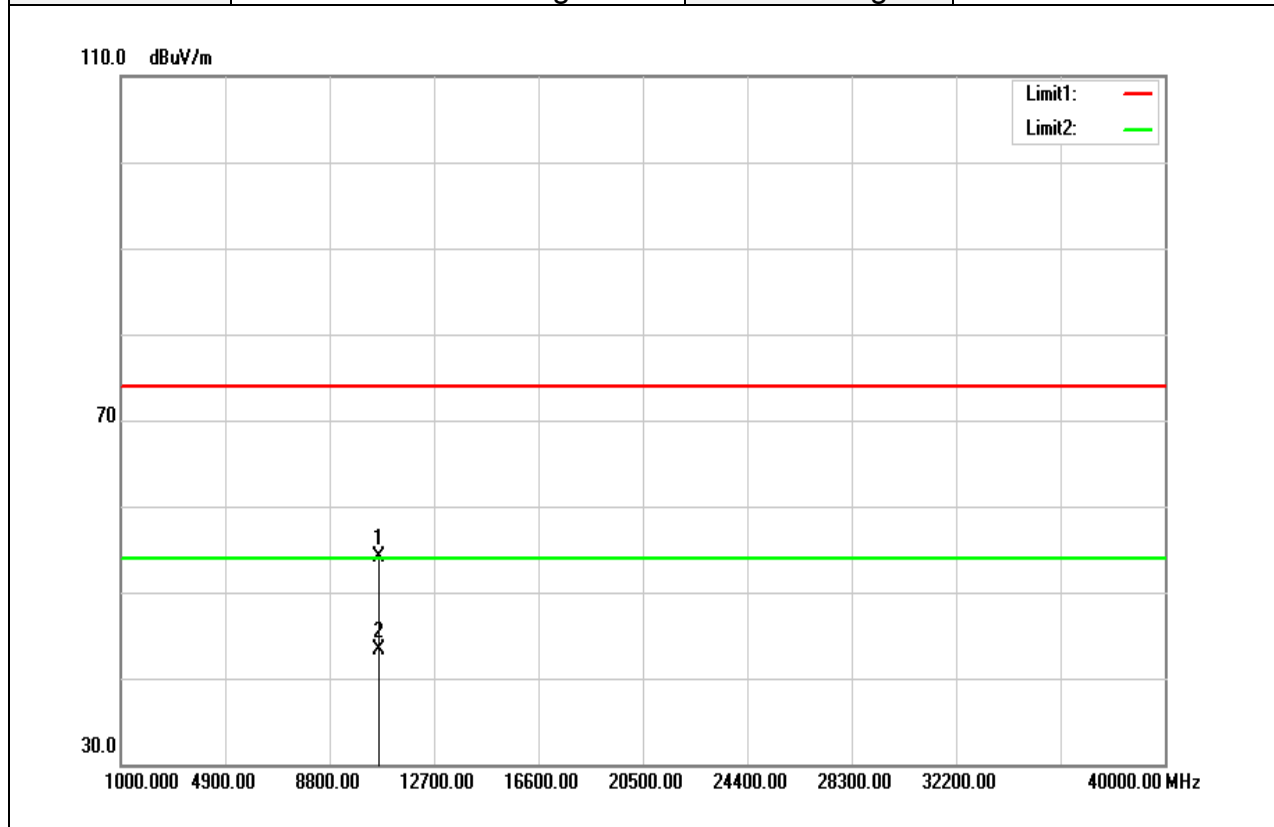

Frequency (MHz)	Reading (dBuV)	Correct Factor (dB/m)	Result (dBuV/m)	Limit (dBuV/m)	Margin (dB)	Remark
10640.000	38.90	15.23	54.13	74.00	-19.87	peak
10640.000	28.02	15.23	43.25	54.00	-10.75	AVG
N/A						

Remark:

1. Measuring frequencies from 1 GHz to the 10th harmonic of highest fundamental frequency.
2. For above 1GHz, the EUT peak value was under average limit, therefore the Average value compliance with the average limit

Test Mode	IEEE 802.11n HT20 / 5320 MHz	Temp/Hum	24(°C)/ 33%RH
Test Item	Harmonic	Test Date	November 30, 2017
Polarize	Horizontal	Test Engineer	Jerry Chuang
Detector	Peak and Average	Test Voltage	120Vac / 60Hz

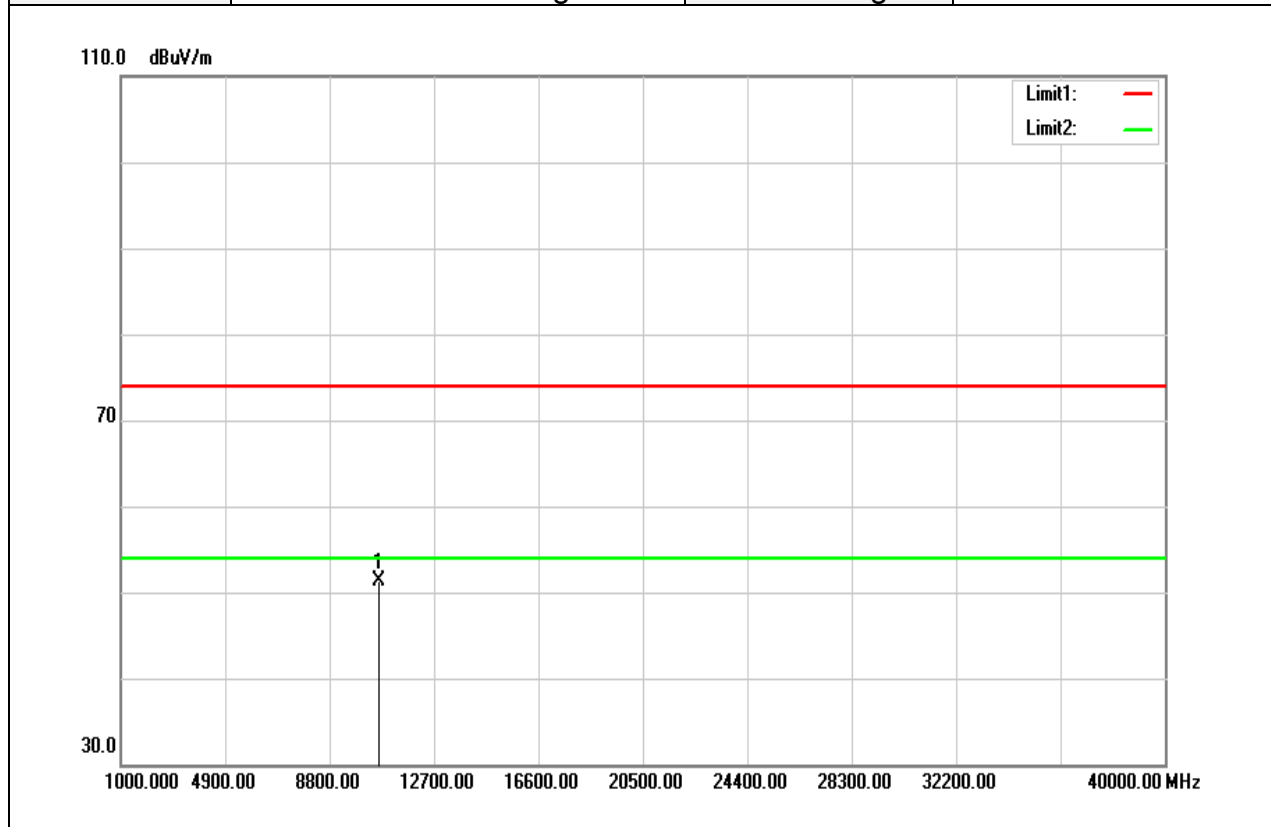

Frequency (MHz)	Reading (dBuV)	Correct Factor (dB/m)	Result (dBuV/m)	Limit (dBuV/m)	Margin (dB)	Remark
10640.000	36.04	15.23	51.27	74.00	-22.73	peak
N/A						

Remark:

1. Measuring frequencies from 1 GHz to the 10th harmonic of highest fundamental frequency.
2. For above 1GHz, the EUT peak value was under average limit, therefore the Average value compliance with the average limit

Test Mode	IEEE 802.11n HT40 / 5270 MHz	Temp/Hum	24(°C)/ 33%RH
Test Item	Harmonic	Test Date	November 30, 2017
Polarize	Vertical	Test Engineer	Jerry Chuang
Detector	Peak and Average	Test Voltage	120Vac / 60Hz

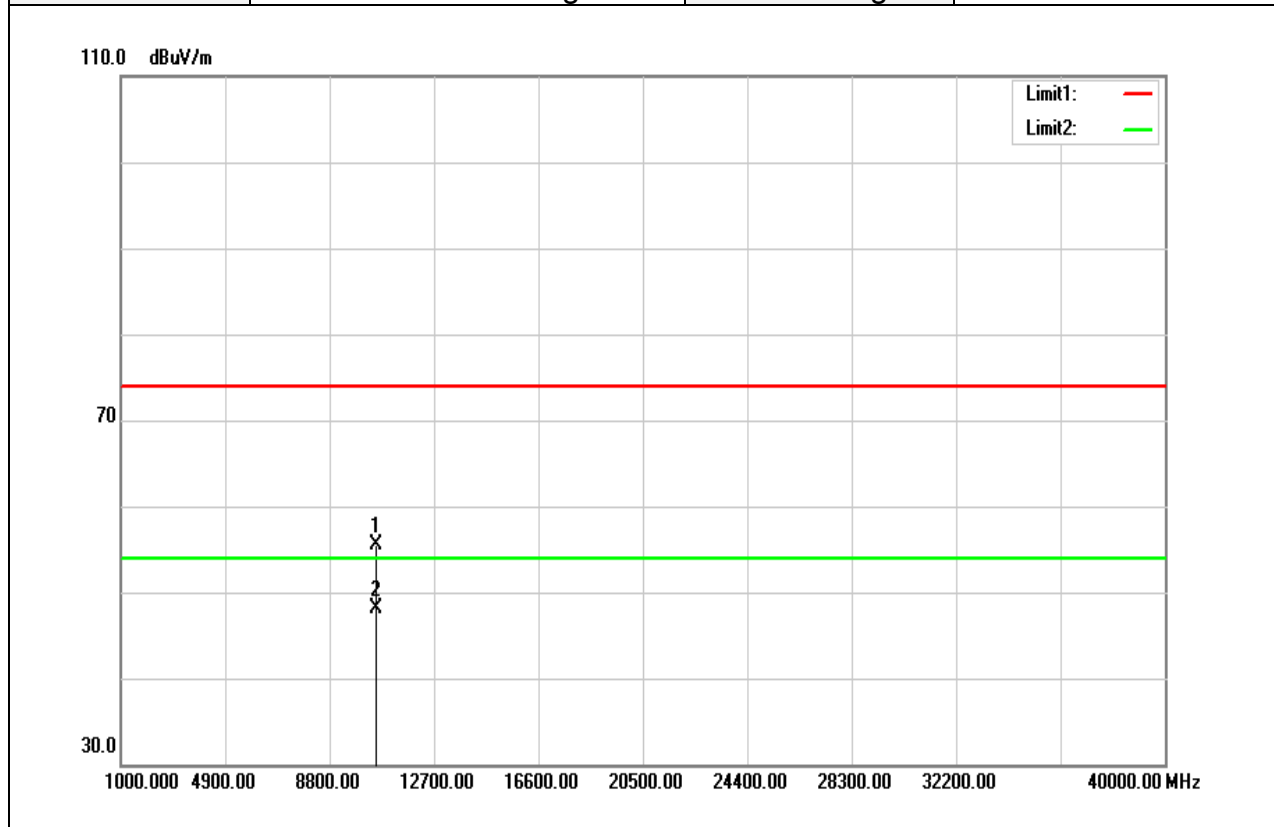

Frequency (MHz)	Reading (dBuV)	Correct Factor (dB/m)	Result (dBuV/m)	Limit (dBuV/m)	Margin (dB)	Remark
10540.000	40.46	15.01	55.47	74.00	-18.53	peak
10540.000	33.05	15.01	48.06	54.00	-5.94	AVG
N/A						

Remark:

1. Measuring frequencies from 1 GHz to the 10th harmonic of highest fundamental frequency.
2. For above 1GHz, the EUT peak value was under average limit, therefore the Average value compliance with the average limit

Test Mode	IEEE 802.11n HT40 / 5270 MHz	Temp/Hum	24(°C)/ 33%RH
Test Item	Harmonic	Test Date	November 30, 2017
Polarize	Horizontal	Test Engineer	Jerry Chuang
Detector	Peak and Average	Test Voltage	120Vac / 60Hz

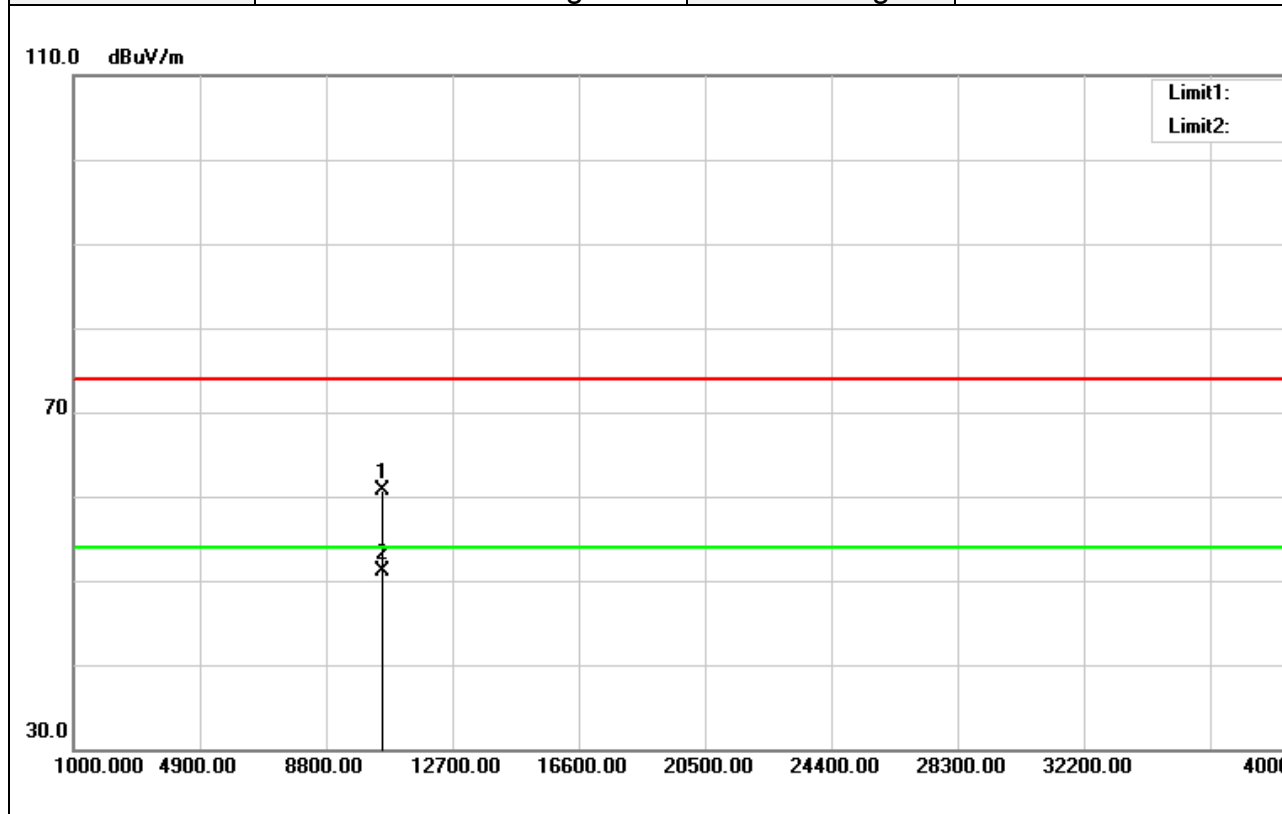

Frequency (MHz)	Reading (dBuV)	Correct Factor (dB/m)	Result (dBuV/m)	Limit (dBuV/m)	Margin (dB)	Remark
10540.000	45.72	15.01	60.73	74.00	-13.27	peak
10540.000	36.17	15.01	51.18	54.00	-2.82	AVG
N/A						

Remark:

1. Measuring frequencies from 1 GHz to the 10th harmonic of highest fundamental frequency.
2. For above 1GHz, the EUT peak value was under average limit, therefore the Average value compliance with the average limit

Test Mode	IEEE 802.11n HT40 / 5310 MHz	Temp/Hum	24(°C)/ 33%RH
Test Item	Harmonic	Test Date	November 30, 2017
Polarize	Vertical	Test Engineer	Jerry Chuang
Detector	Peak and Average	Test Voltage	120Vac / 60Hz

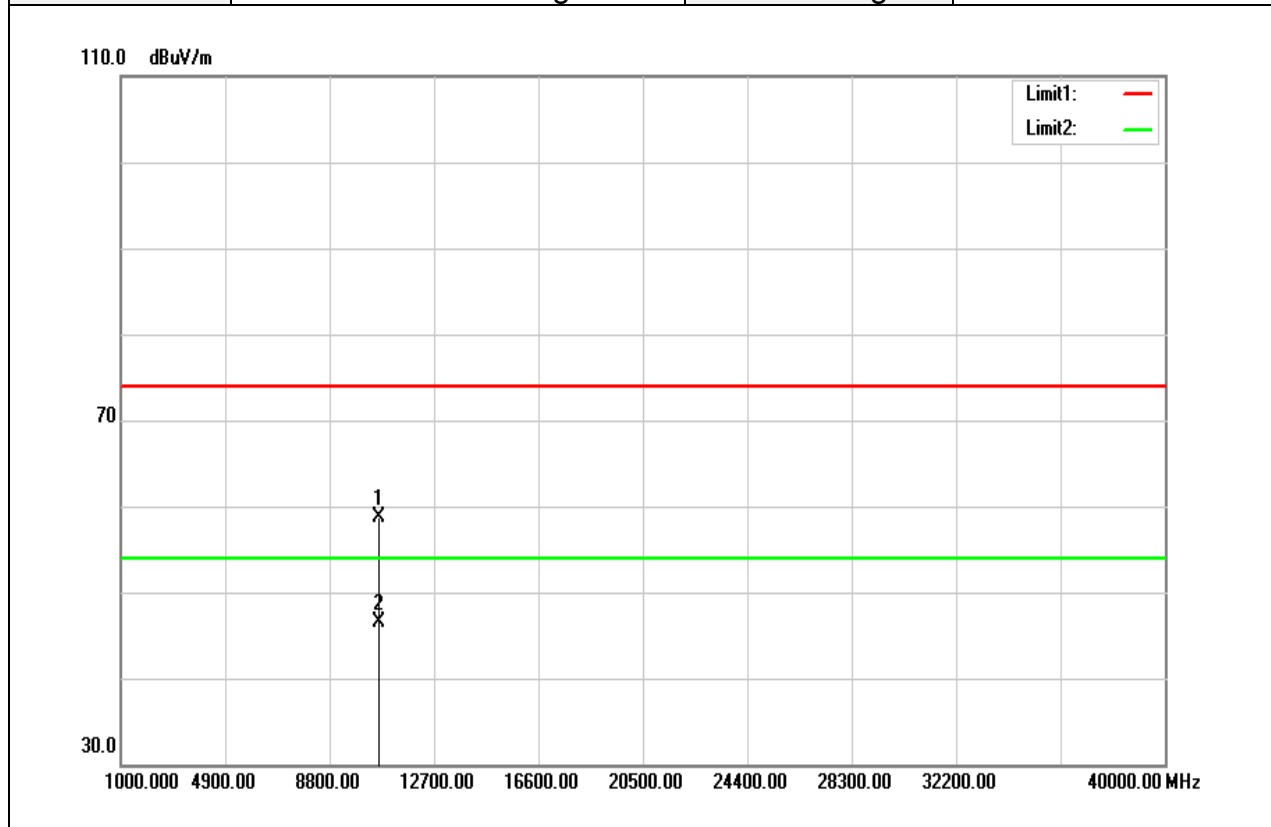

Frequency (MHz)	Reading (dBuV)	Correct Factor (dB/m)	Result (dBuV/m)	Limit (dBuV/m)	Margin (dB)	Remark
10620.000	43.50	15.20	58.70	74.00	-15.30	peak
10620.000	31.30	15.20	46.50	54.00	-7.50	AVG
N/A						

Remark:

1. Measuring frequencies from 1 GHz to the 10th harmonic of highest fundamental frequency.
2. For above 1GHz, the EUT peak value was under average limit, therefore the Average value compliance with the average limit

Test Mode	IEEE 802.11n HT40 / 5310 MHz	Temp/Hum	24(°C)/ 33%RH
Test Item	Harmonic	Test Date	November 30, 2017
Polarize	Horizontal	Test Engineer	Jerry Chuang
Detector	Peak and Average	Test Voltage	120Vac / 60Hz

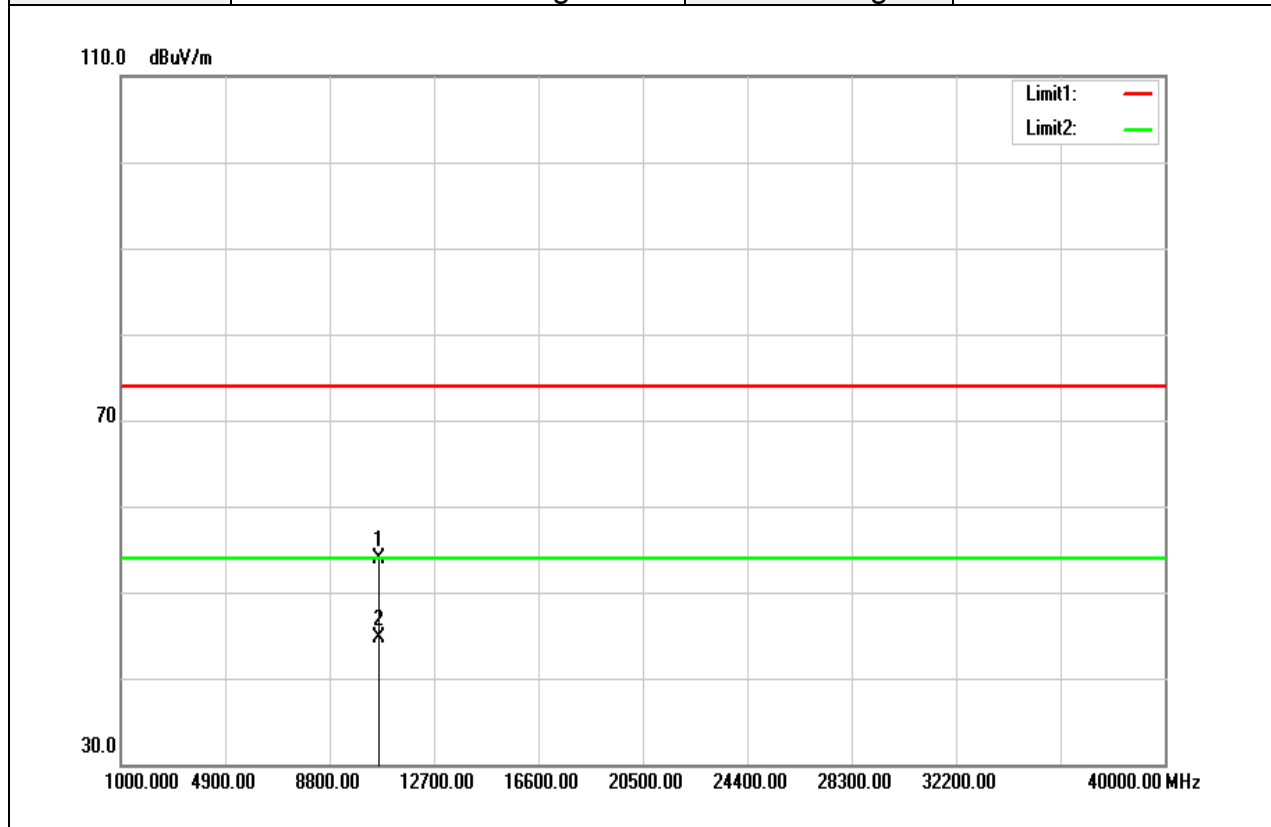

Frequency (MHz)	Reading (dBuV)	Correct Factor (dB/m)	Result (dBuV/m)	Limit (dBuV/m)	Margin (dB)	Remark
10620.000	38.78	15.20	53.98	74.00	-20.02	peak
10620.000	29.60	15.20	44.80	54.00	-9.20	AVG
N/A						

Remark:

1. Measuring frequencies from 1 GHz to the 10th harmonic of highest fundamental frequency.
2. For above 1GHz, the EUT peak value was under average limit, therefore the Average value compliance with the average limit

Test Mode	IEEE 802.11ac VHT80 / 5290 MHz	Temp/Hum	24(°C)/ 33%RH
Test Item	Harmonic	Test Date	November 30, 2017
Polarize	Vertical	Test Engineer	Jerry Chuang
Detector	Peak and Average	Test Voltage	120Vac / 60Hz

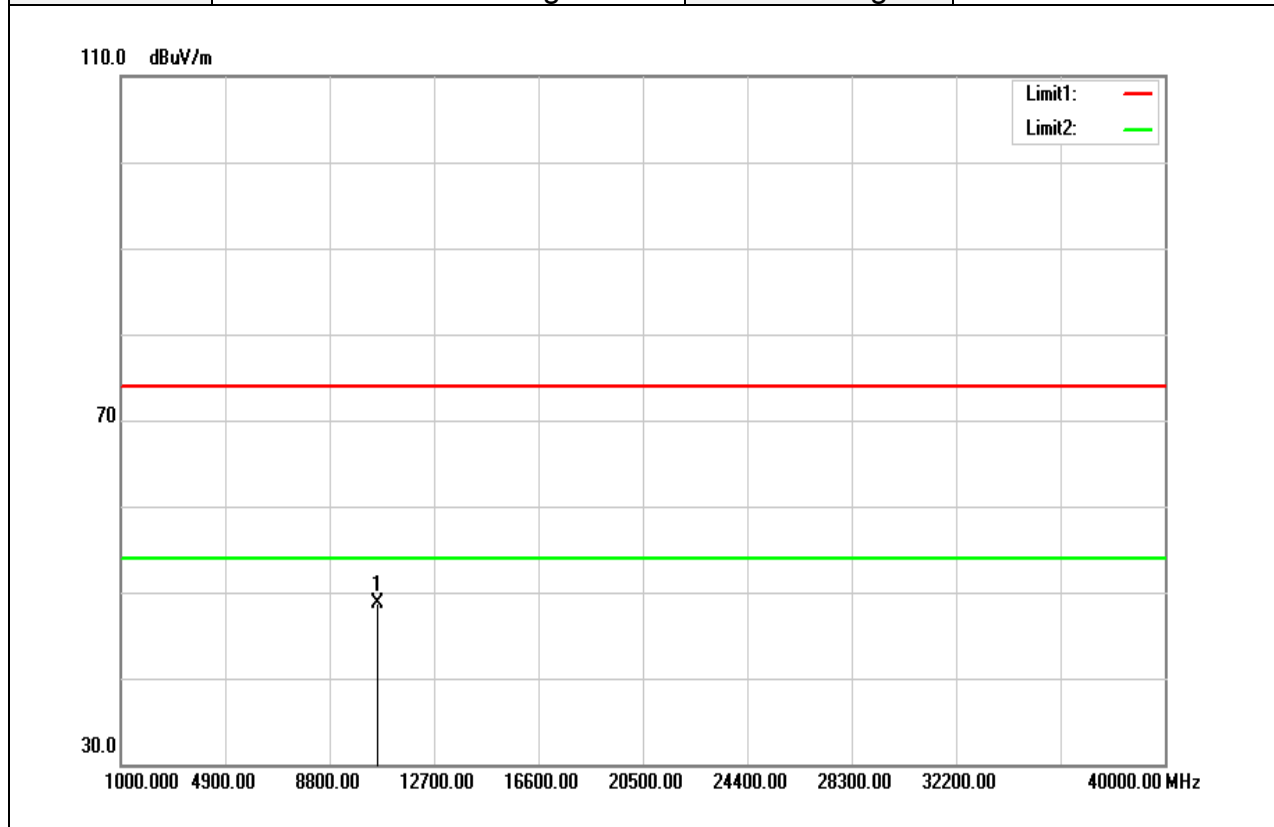

Frequency (MHz)	Reading (dBuV)	Correct Factor (dB/m)	Result (dBuV/m)	Limit (dBuV/m)	Margin (dB)	Remark
10580.000	33.59	15.10	48.69	74.00	-25.31	peak
N/A						

Remark:

1. Measuring frequencies from 1 GHz to the 10th harmonic of highest fundamental frequency.
2. For above 1GHz, the EUT peak value was under average limit, therefore the Average value compliance with the average limit

Test Mode	IEEE 802.11ac VHT80 / 5290 MHz	Temp/Hum	24(°C)/ 33%RH
Test Item	Harmonic	Test Date	November 30, 2017
Polarize	Horizontal	Test Engineer	Jerry Chuang
Detector	Peak and Average	Test Voltage	120Vac / 60Hz

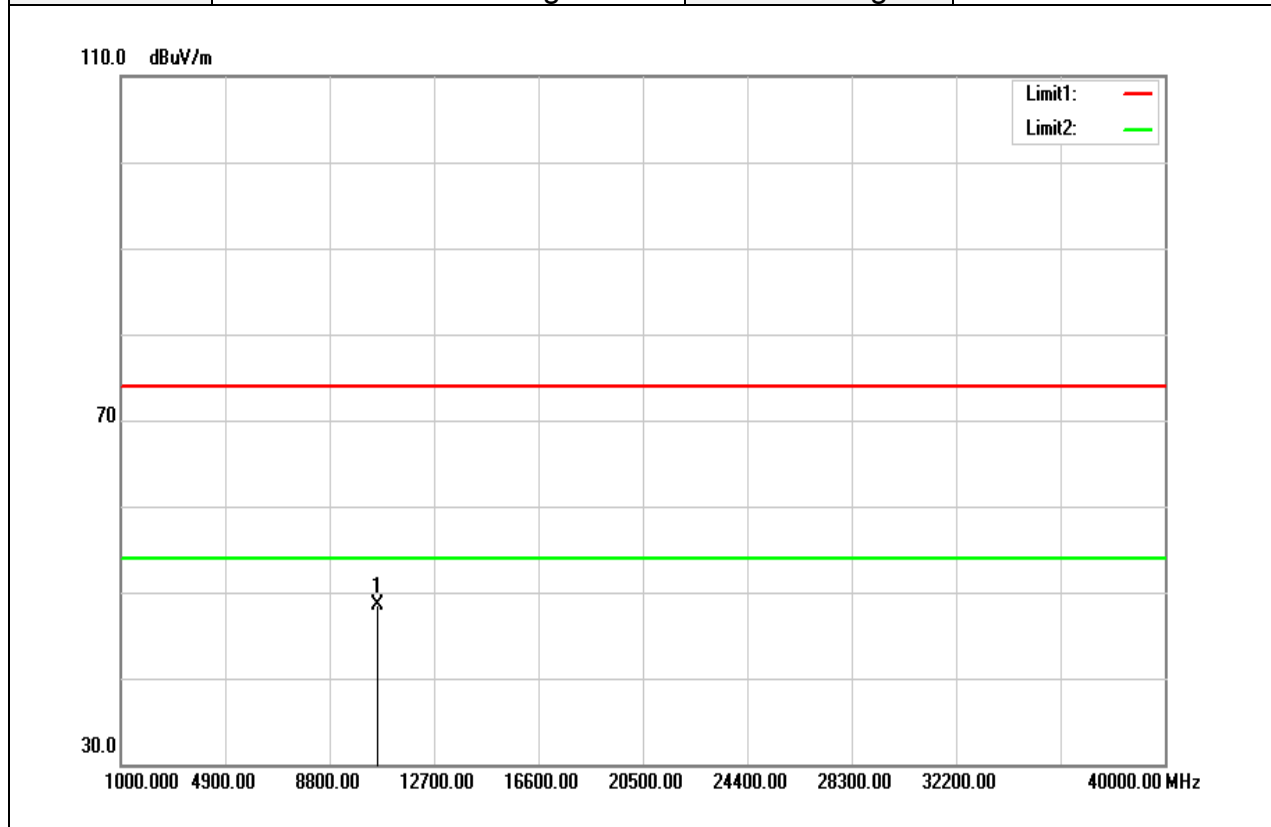

Frequency (MHz)	Reading (dBuV)	Correct Factor (dB/m)	Result (dBuV/m)	Limit (dBuV/m)	Margin (dB)	Remark
10580.000	33.32	15.10	48.42	74.00	-25.58	peak
N/A						

Remark:

1. Measuring frequencies from 1 GHz to the 10th harmonic of highest fundamental frequency.
2. For above 1GHz, the EUT peak value was under average limit, therefore the Average value compliance with the average limit

Above 1G Test Data for UNII-2c

Test Mode	IEEE 802.11a / 5500 MHz	Temp/Hum	24(°C)/ 33%RH
Test Item	Harmonic	Test Date	November 30, 2017
Polarize	Vertical	Test Engineer	Jerry Chuang
Detector	Peak and Average	Test Voltage	120Vac / 60Hz

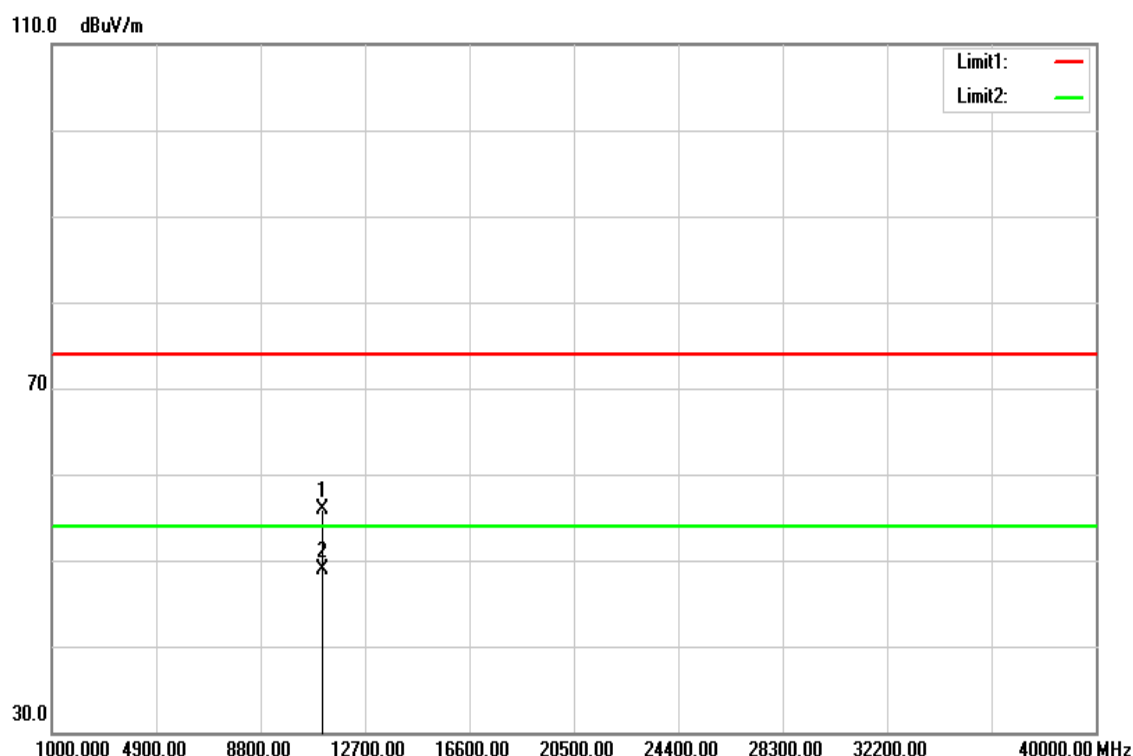

Frequency (MHz)	Reading (dBuV)	Correct Factor (dB/m)	Result (dBuV/m)	Limit (dBuV/m)	Margin (dB)	Remark
11100.000	39.78	16.07	55.85	74.00	-18.15	peak
11100.000	32.75	16.07	48.82	54.00	-5.18	AVG
N/A						

Remark:

1. Measuring frequencies from 1 GHz to the 10th harmonic of highest fundamental frequency.
2. For above 1GHz, the EUT peak value was under average limit, therefore the Average value compliance with the average limit

Test Mode	IEEE 802.11a / 5500 MHz	Temp/Hum	24(°C)/ 33%RH
Test Item	Harmonic	Test Date	November 30, 2017
Polarize	Horizontal	Test Engineer	Jerry Chuang
Detector	Peak and Average	Test Voltage	120Vac / 60Hz

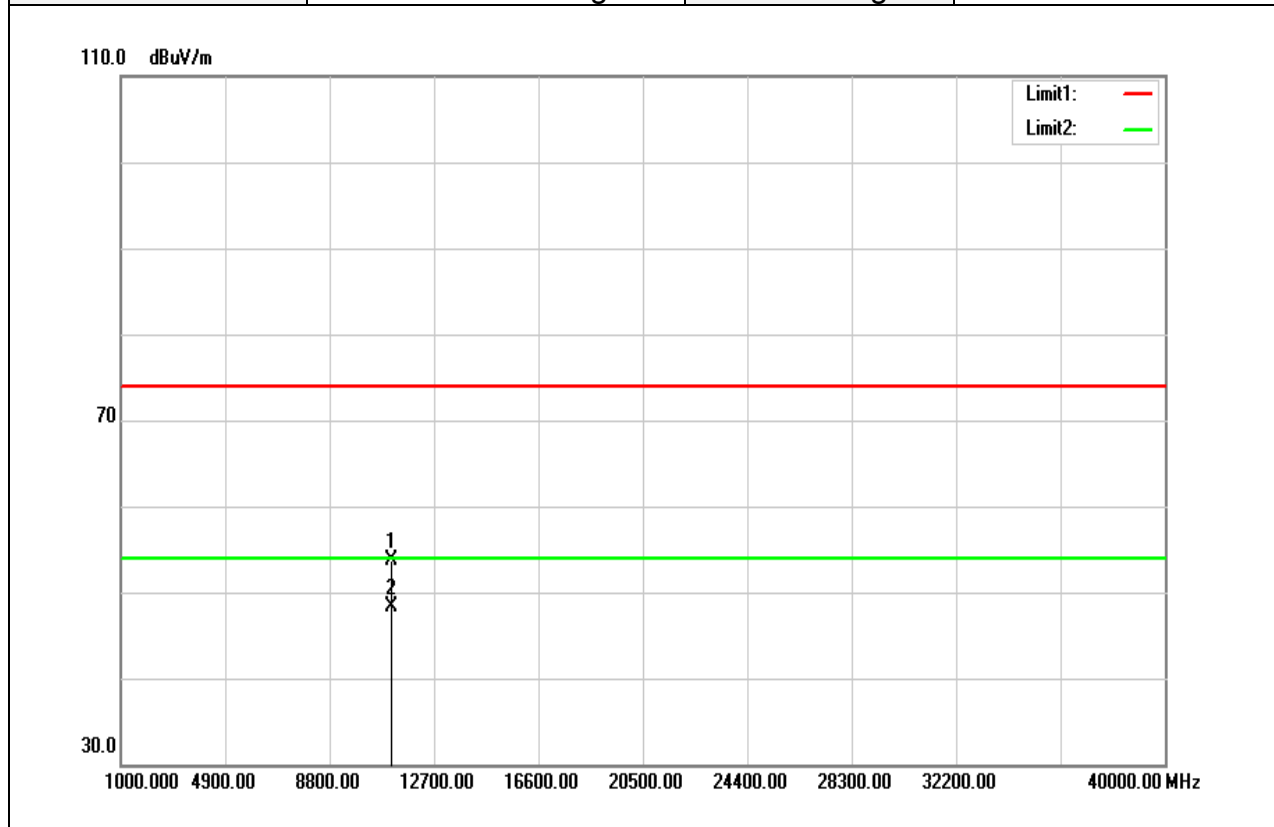

Frequency (MHz)	Reading (dBuV)	Correct Factor (dB/m)	Result (dBuV/m)	Limit (dBuV/m)	Margin (dB)	Remark
11100.000	37.63	16.07	53.70	74.00	-20.30	peak
11100.000	32.25	16.07	48.32	54.00	-5.68	AVG
N/A						

Remark:

1. Measuring frequencies from 1 GHz to the 10th harmonic of highest fundamental frequency.
2. For above 1GHz, the EUT peak value was under average limit, therefore the Average value compliance with the average limit

Test Mode	IEEE 802.11a / 5580 MHz	Temp/Hum	24(°C)/ 33%RH
Test Item	Harmonic	Test Date	November 30, 2017
Polarize	Vertical	Test Engineer	Jerry Chuang
Detector	Peak and Average	Test Voltage	120Vac / 60Hz

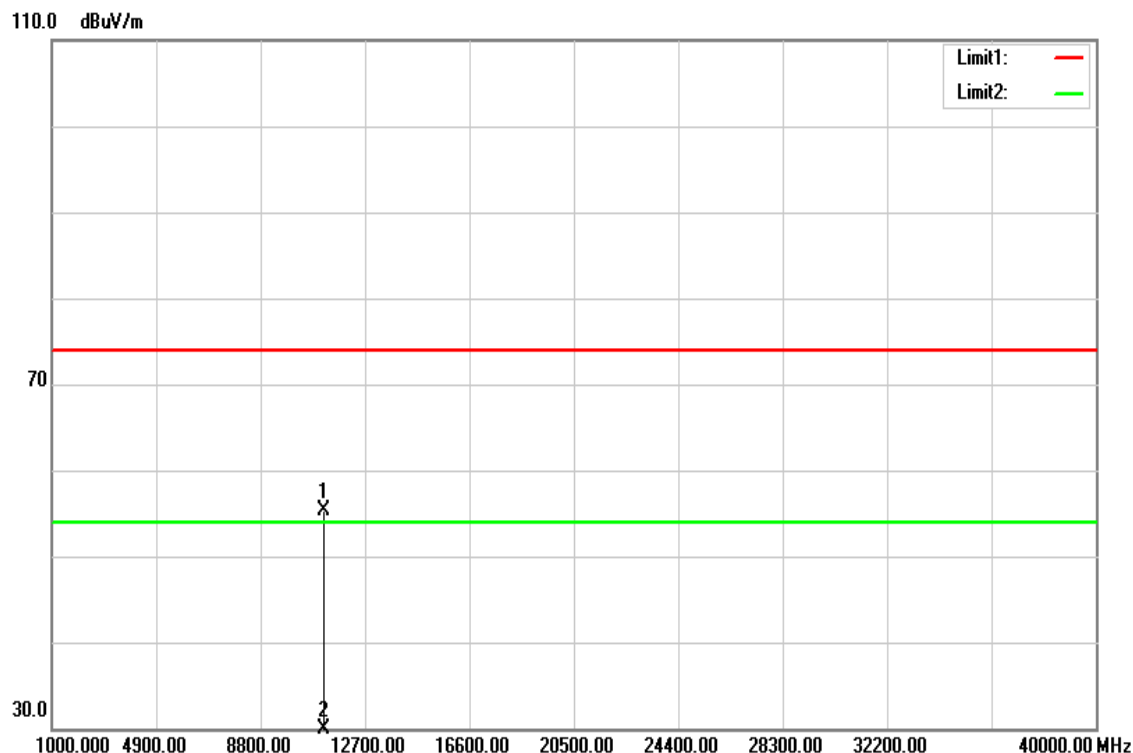

Frequency (MHz)	Reading (dBuV)	Correct Factor (dB/m)	Result (dBuV/m)	Limit (dBuV/m)	Margin (dB)	Remark
11170.000	39.31	16.06	55.37	74.00	-18.63	peak
11170.000	-7.38	16.06	8.68	54.00	-45.32	AVG
N/A						

Remark:

1. Measuring frequencies from 1 GHz to the 10th harmonic of highest fundamental frequency.
2. For above 1GHz, the EUT peak value was under average limit, therefore the Average value compliance with the average limit

Test Mode	IEEE 802.11a / 5580 MHz	Temp/Hum	24(°C)/ 33%RH
Test Item	Harmonic	Test Date	November 30, 2017
Polarize	Horizontal	Test Engineer	Jerry Chuang
Detector	Peak and Average	Test Voltage	120Vac / 60Hz

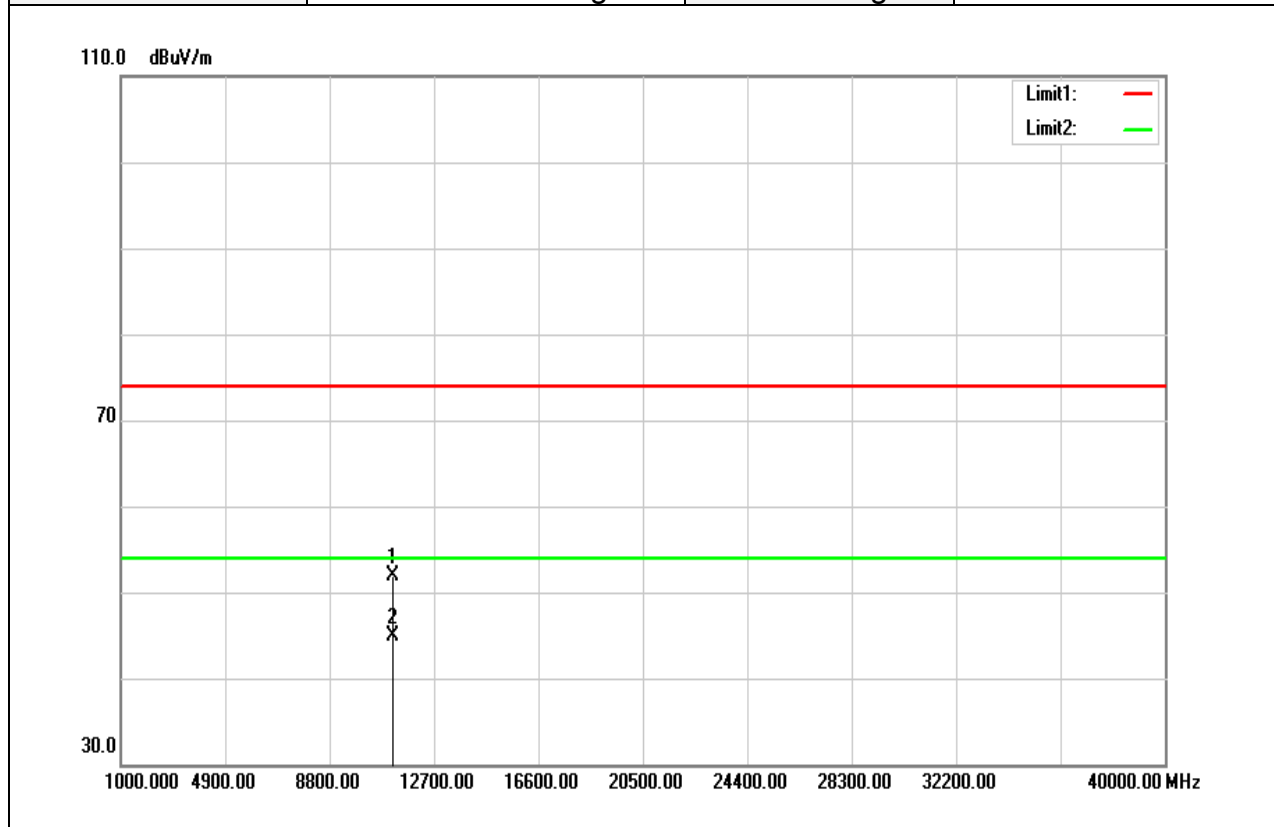

Frequency (MHz)	Reading (dBuV)	Correct Factor (dB/m)	Result (dBuV/m)	Limit (dBuV/m)	Margin (dB)	Remark
11170.000	35.92	16.06	51.98	74.00	-22.02	peak
11170.000	28.81	16.06	44.87	54.00	-9.13	AVG
N/A						

Remark:

1. Measuring frequencies from 1 GHz to the 10th harmonic of highest fundamental frequency.
2. For above 1GHz, the EUT peak value was under average limit, therefore the Average value compliance with the average limit

Test Mode	IEEE 802.11a / 5700 MHz	Temp/Hum	24(°C)/ 33%RH
Test Item	Harmonic	Test Date	November 30, 2017
Polarize	Vertical	Test Engineer	Jerry Chuang
Detector	Peak and Average	Test Voltage	120Vac / 60Hz

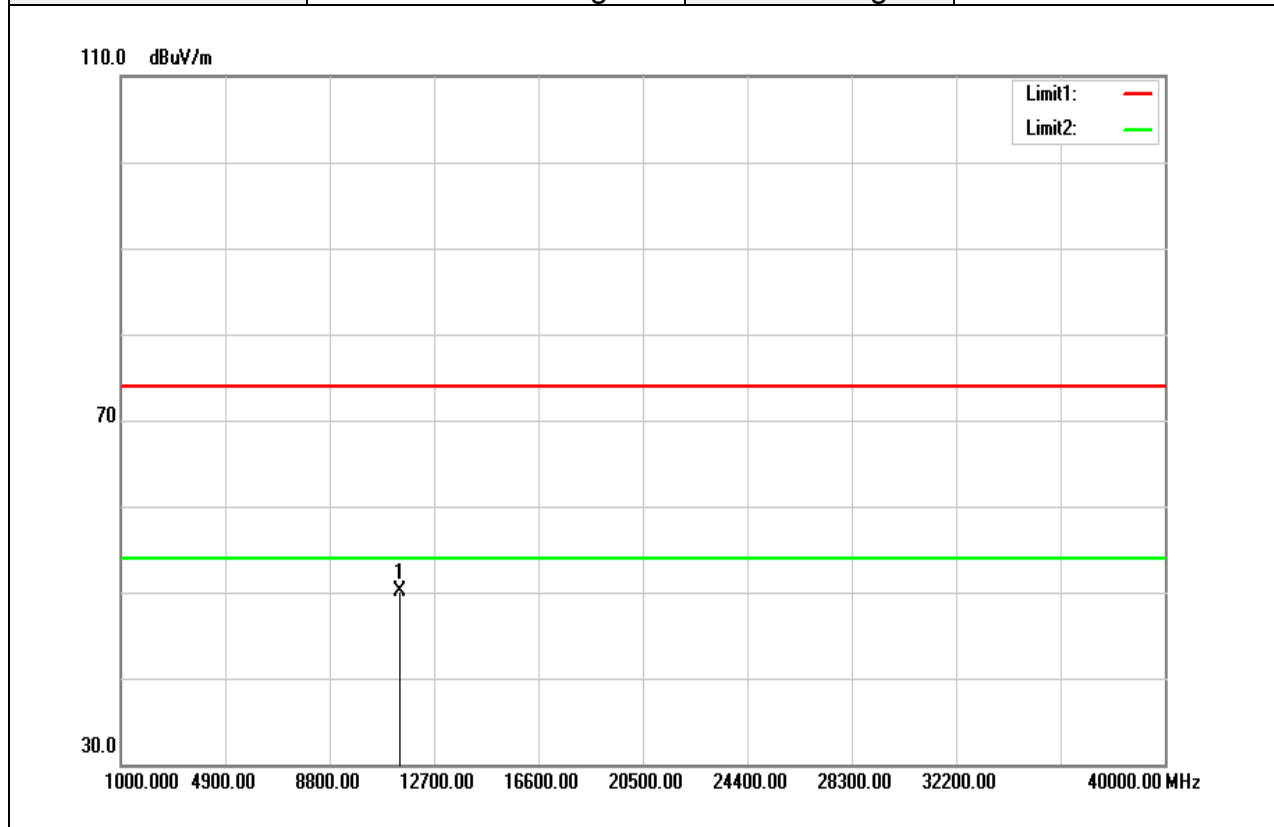

Frequency (MHz)	Reading (dBuV)	Correct Factor (dB/m)	Result (dBuV/m)	Limit (dBuV/m)	Margin (dB)	Remark
11400.000	34.11	16.08	50.19	74.00	-23.81	peak
N/A						

Remark:

1. Measuring frequencies from 1 GHz to the 10th harmonic of highest fundamental frequency.
2. For above 1GHz, the EUT peak value was under average limit, therefore the Average value compliance with the average limit

Test Mode	IEEE 802.11a / 5700 MHz	Temp/Hum	24(°C)/ 33%RH
Test Item	Harmonic	Test Date	November 30, 2017
Polarize	Horizontal	Test Engineer	Jerry Chuang
Detector	Peak and Average	Test Voltage	120Vac / 60Hz

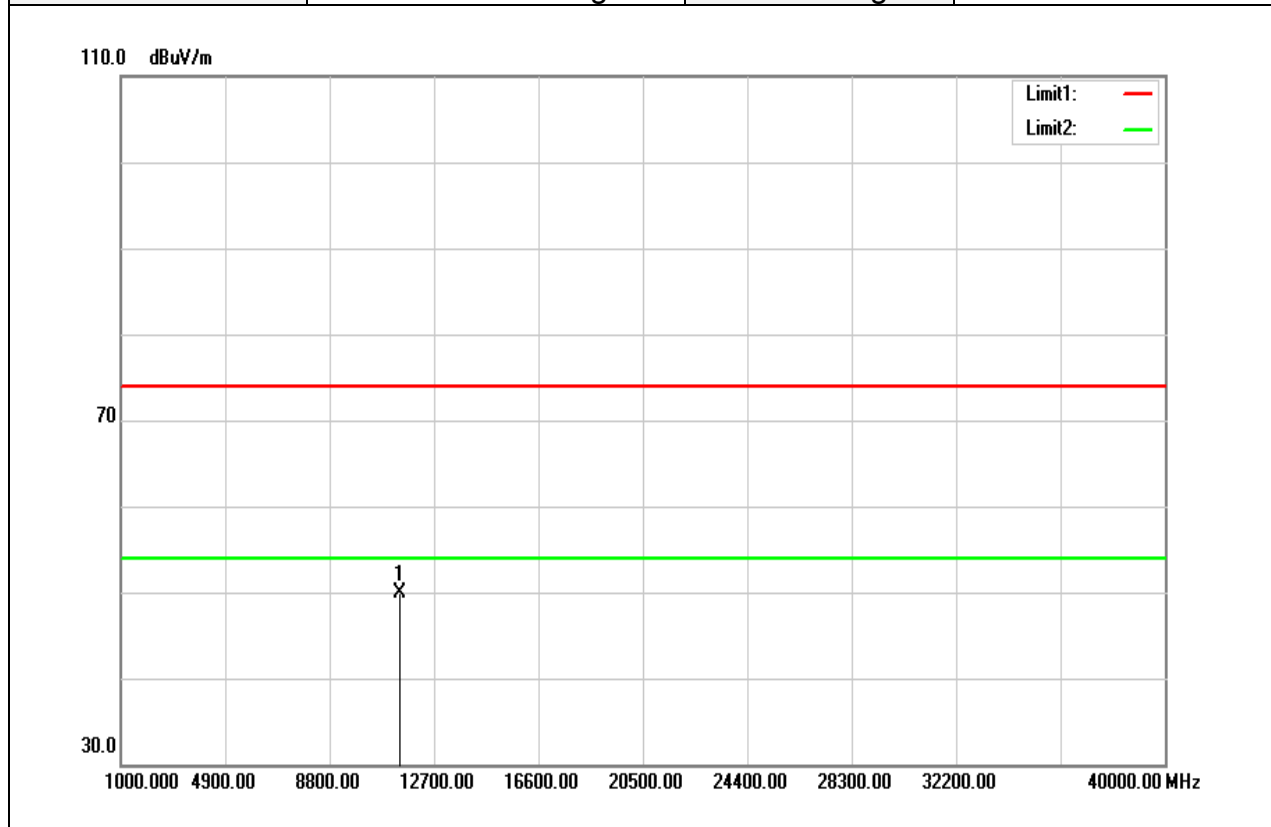

Frequency (MHz)	Reading (dBuV)	Correct Factor (dB/m)	Result (dBuV/m)	Limit (dBuV/m)	Margin (dB)	Remark
11400.000	33.80	16.08	49.88	74.00	-24.12	peak
N/A						

Remark:

1. Measuring frequencies from 1 GHz to the 10th harmonic of highest fundamental frequency.
2. For above 1GHz, the EUT peak value was under average limit, therefore the Average value compliance with the average limit

Test Mode	IEEE 802.11a / 5720 MHz	Temp/Hum	24(°C)/ 33%RH
Test Item	Harmonic	Test Date	November 30, 2017
Polarize	Vertical	Test Engineer	Jerry Chuang
Detector	Peak and Average	Test Voltage	120Vac / 60Hz

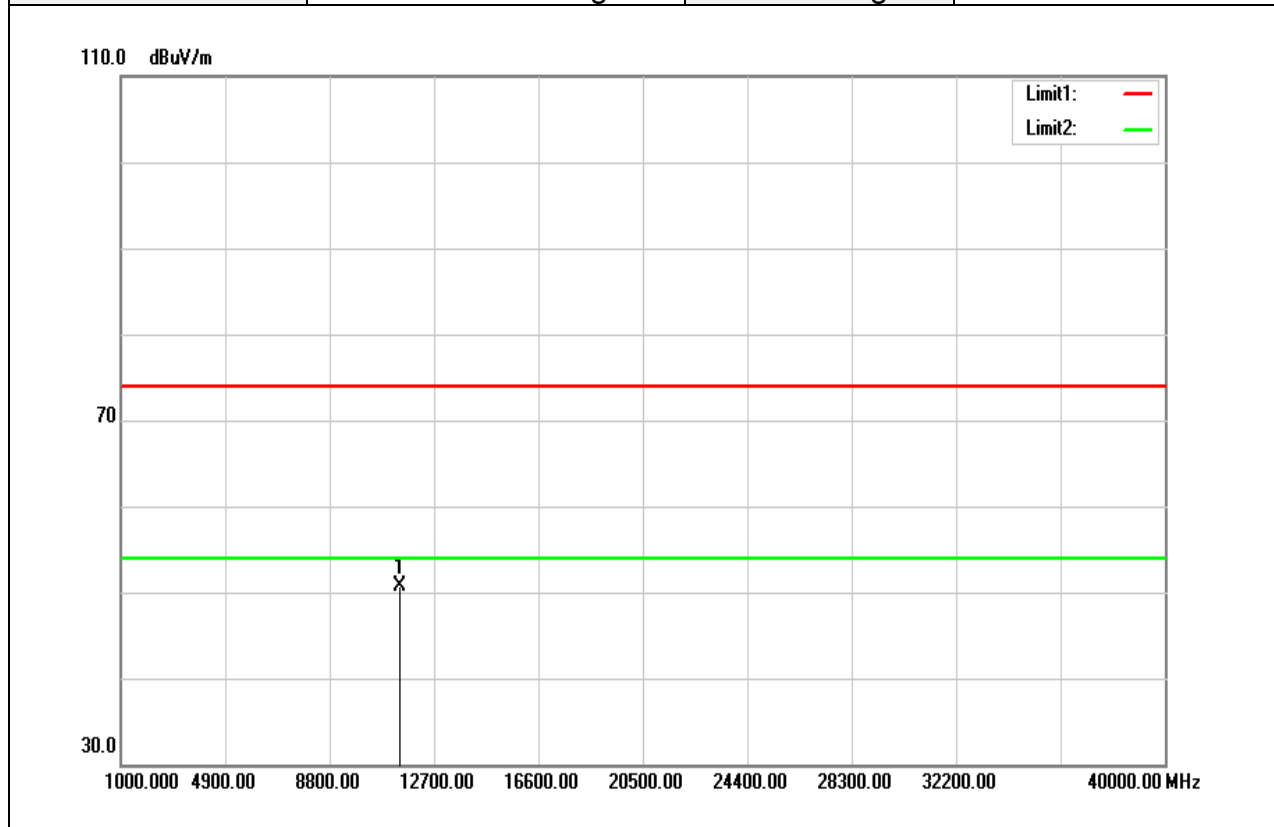

Frequency (MHz)	Reading (dBuV)	Correct Factor (dB/m)	Result (dBuV/m)	Limit (dBuV/m)	Margin (dB)	Remark
11440.000	34.57	16.09	50.66	74.00	-23.34	peak
N/A						

Remark:

1. Measuring frequencies from 1 GHz to the 10th harmonic of highest fundamental frequency.
2. For above 1GHz, the EUT peak value was under average limit, therefore the Average value compliance with the average limit

Test Mode	IEEE 802.11a / 5720 MHz	Temp/Hum	24(°C)/ 33%RH
Test Item	Harmonic	Test Date	November 30, 2017
Polarize	Horizontal	Test Engineer	Jerry Chuang
Detector	Peak and Average	Test Voltage	120Vac / 60Hz

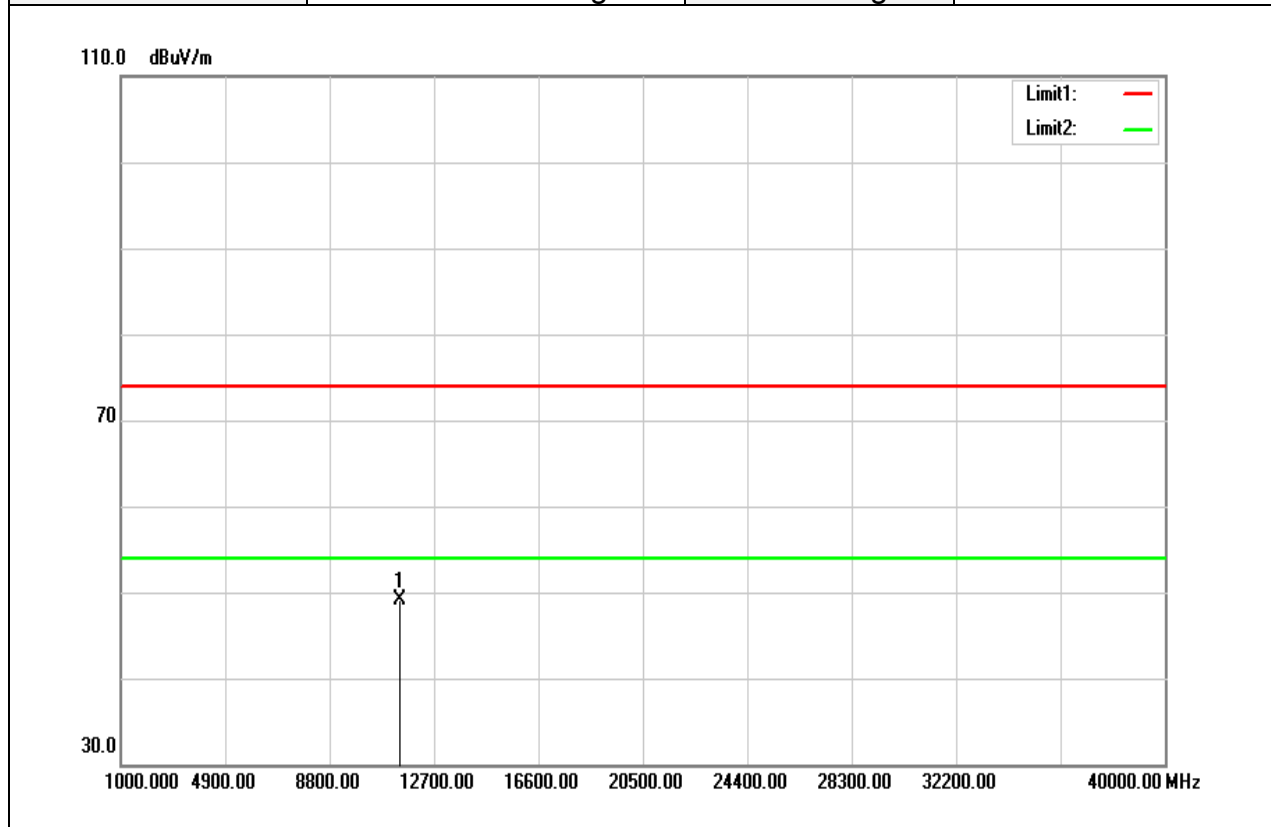

Frequency (MHz)	Reading (dBuV)	Correct Factor (dB/m)	Result (dBuV/m)	Limit (dBuV/m)	Margin (dB)	Remark
11440.000	32.99	16.09	49.08	74.00	-24.92	peak
N/A						

Remark:

1. Measuring frequencies from 1 GHz to the 10th harmonic of highest fundamental frequency.
2. For above 1GHz, the EUT peak value was under average limit, therefore the Average value compliance with the average limit

Test Mode	IEEE 802.11n HT20 / 5500 MHz	Temp/Hum	24(°C)/ 33%RH
Test Item	Harmonic	Test Date	November 30, 2017
Polarize	Vertical	Test Engineer	Jerry Chuang
Detector	Peak and Average	Test Voltage	120Vac / 60Hz

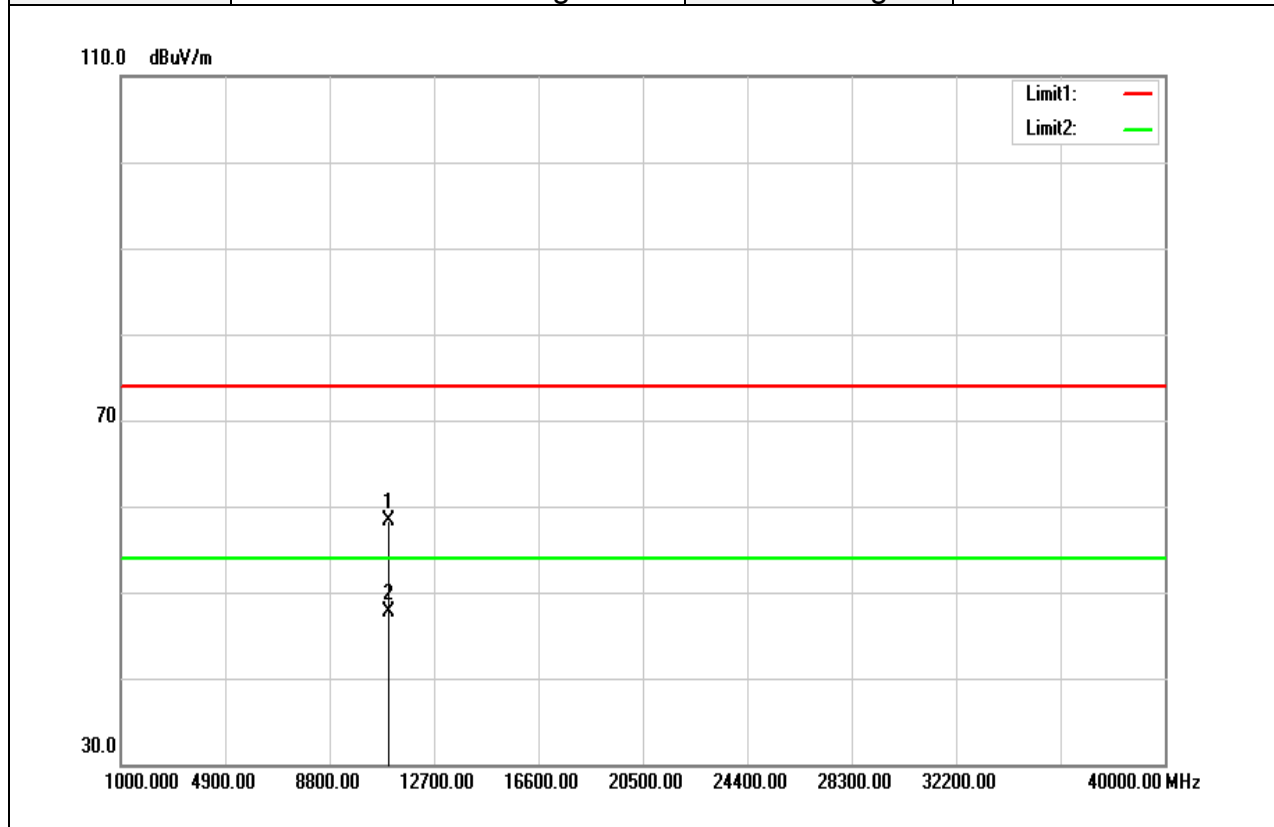

Frequency (MHz)	Reading (dBuV)	Correct Factor (dB/m)	Result (dBuV/m)	Limit (dBuV/m)	Margin (dB)	Remark
10990.000	42.32	16.04	58.36	74.00	-15.64	peak
10990.000	31.75	16.04	47.79	54.00	-6.21	AVG
N/A						

Remark:

1. Measuring frequencies from 1 GHz to the 10th harmonic of highest fundamental frequency.
2. For above 1GHz, the EUT peak value was under average limit, therefore the Average value compliance with the average limit

Test Mode	IEEE 802.11n HT20 / 5500 MHz	Temp/Hum	24(°C)/ 33%RH
Test Item	Harmonic	Test Date	November 30, 2017
Polarize	Horizontal	Test Engineer	Jerry Chuang
Detector	Peak and Average	Test Voltage	120Vac / 60Hz

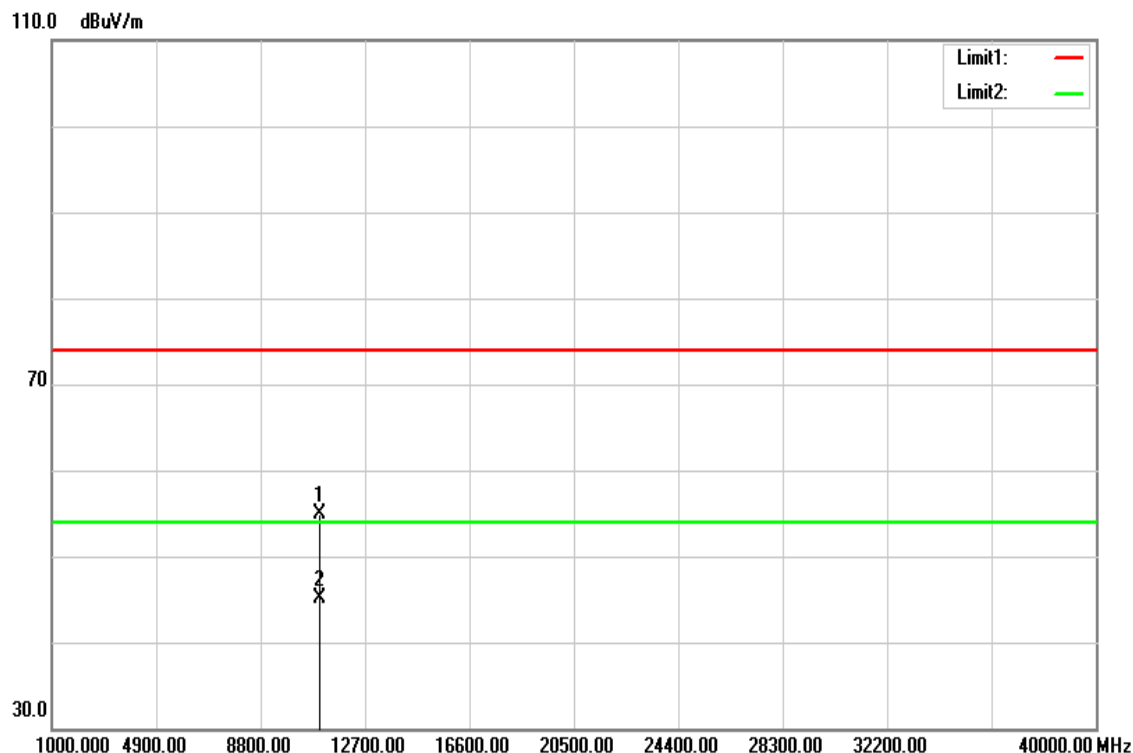

Frequency (MHz)	Reading (dBuV)	Correct Factor (dB/m)	Result (dBuV/m)	Limit (dBuV/m)	Margin (dB)	Remark
11010.000	38.92	16.06	54.98	74.00	-19.02	peak
11010.000	29.06	16.06	45.12	54.00	-8.88	AVG
N/A						

Remark:

1. Measuring frequencies from 1 GHz to the 10th harmonic of highest fundamental frequency.
2. For above 1GHz, the EUT peak value was under average limit, therefore the Average value compliance with the average limit

Test Mode	IEEE 802.11n HT20 / 5580 MHz	Temp/Hum	24(°C)/ 33%RH
Test Item	Harmonic	Test Date	November 30, 2017
Polarize	Vertical	Test Engineer	Jerry Chuang
Detector	Peak and Average	Test Voltage	120Vac / 60Hz

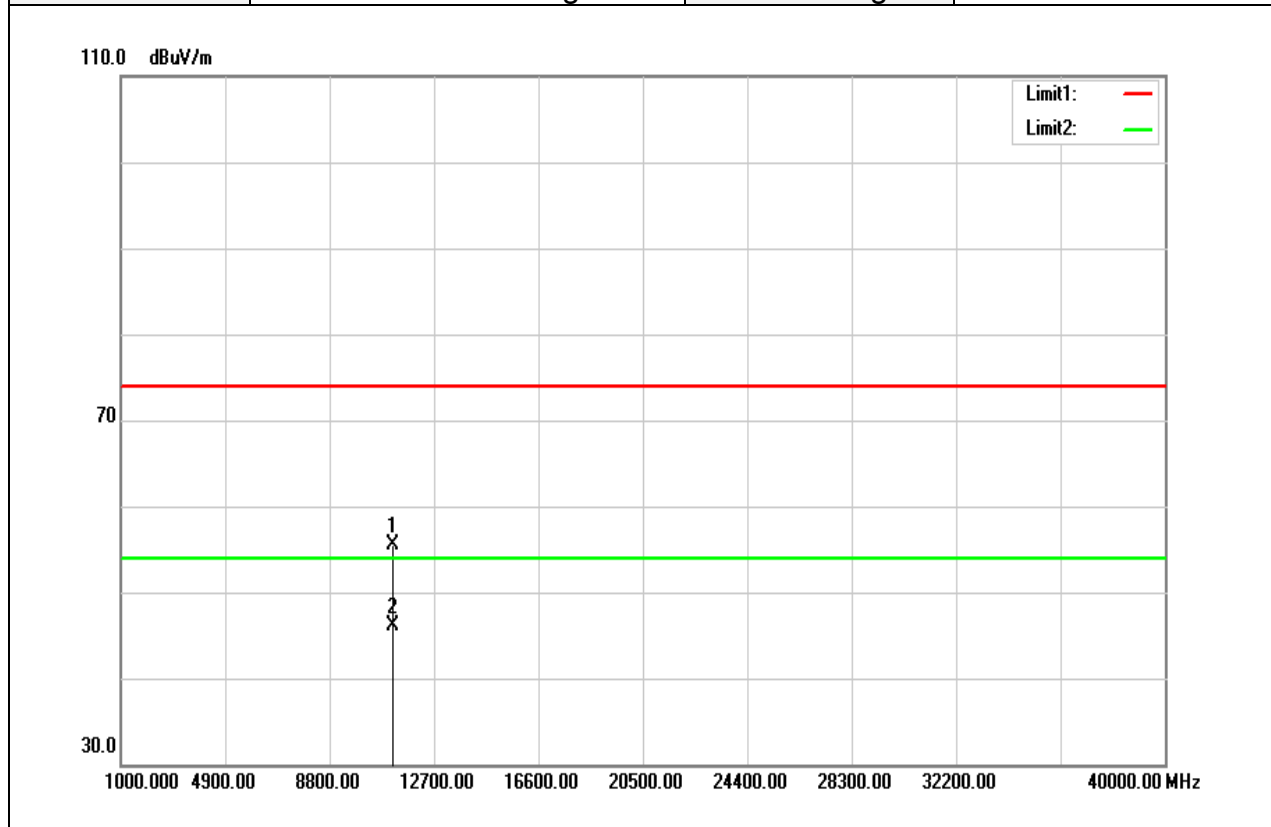

Frequency (MHz)	Reading (dBuV)	Correct Factor (dB/m)	Result (dBuV/m)	Limit (dBuV/m)	Margin (dB)	Remark
11160.000	39.37	16.07	55.44	74.00	-18.56	peak
11160.000	29.96	16.07	46.03	54.00	-7.97	AVG
N/A						

Remark:

1. Measuring frequencies from 1 GHz to the 10th harmonic of highest fundamental frequency.
2. For above 1GHz, the EUT peak value was under average limit, therefore the Average value compliance with the average limit

Test Mode	IEEE 802.11n HT20 / 5580 MHz	Temp/Hum	24(°C)/ 33%RH
Test Item	Harmonic	Test Date	November 30, 2017
Polarize	Horizontal	Test Engineer	Jerry Chuang
Detector	Peak and Average	Test Voltage	120Vac / 60Hz

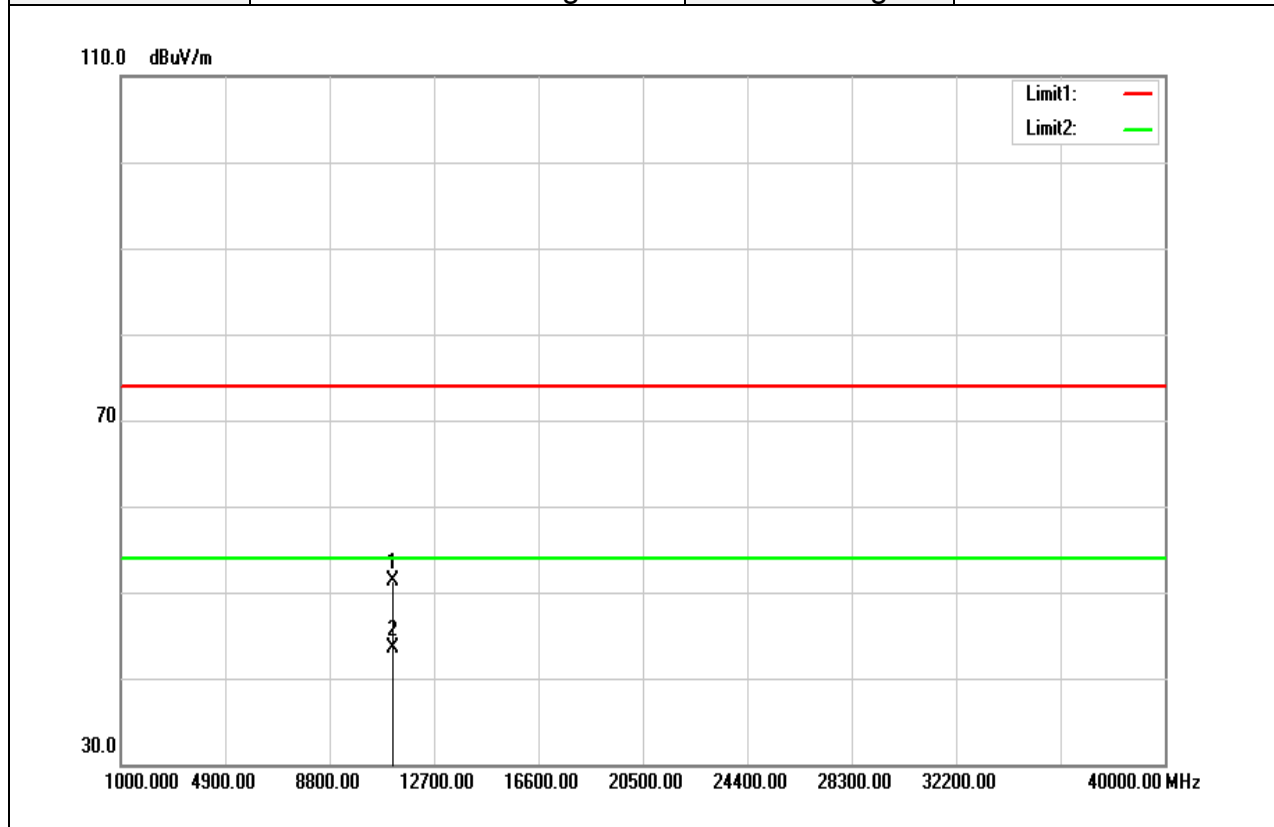

Frequency (MHz)	Reading (dBuV)	Correct Factor (dB/m)	Result (dBuV/m)	Limit (dBuV/m)	Margin (dB)	Remark
11160.000	35.31	16.07	51.38	74.00	-22.62	peak
11160.000	27.38	16.07	43.45	54.00	-10.55	AVG
N/A						

Remark:

1. Measuring frequencies from 1 GHz to the 10th harmonic of highest fundamental frequency.
2. For above 1GHz, the EUT peak value was under average limit, therefore the Average value compliance with the average limit

Test Mode	IEEE 802.11n HT20 / 5700 MHz	Temp/Hum	24(°C)/ 33%RH
Test Item	Harmonic	Test Date	November 30, 2017
Polarize	Vertical	Test Engineer	Jerry Chuang
Detector	Peak and Average	Test Voltage	120Vac / 60Hz

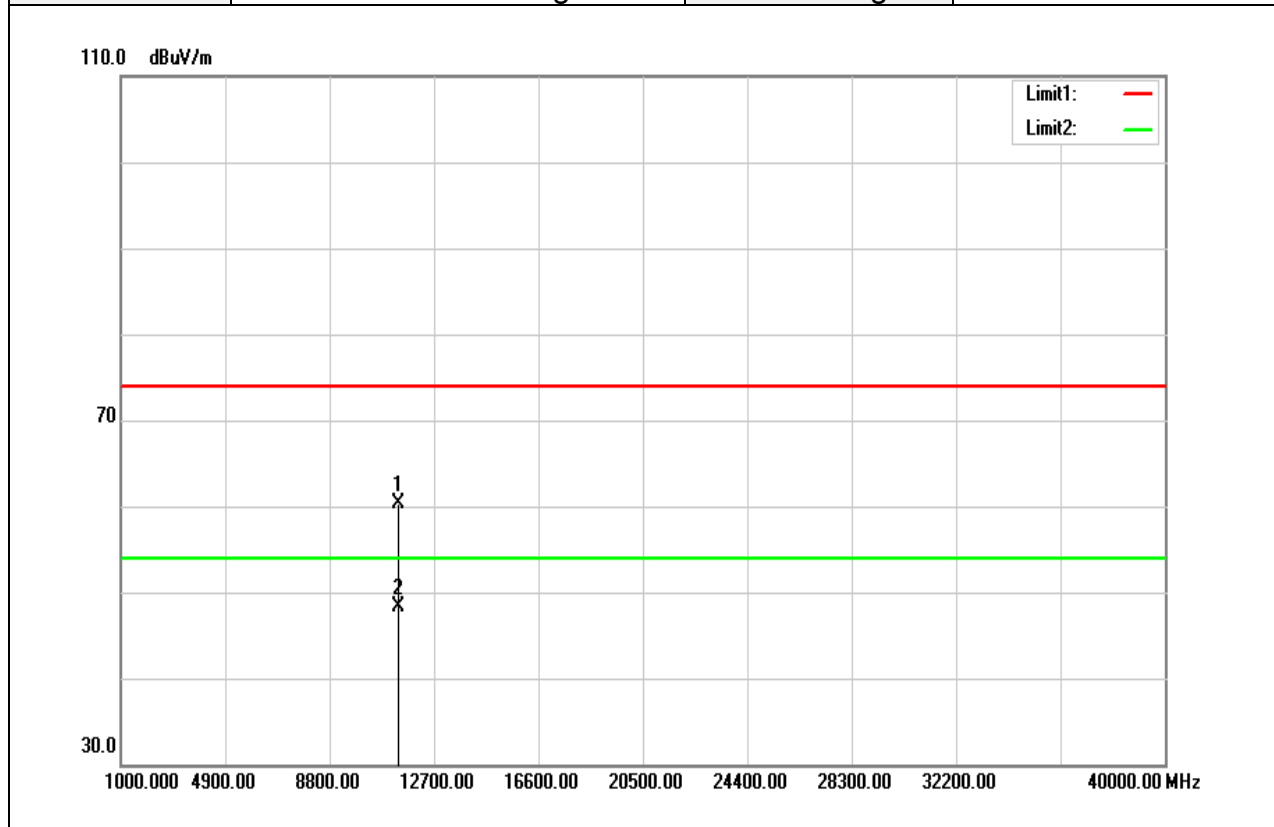

Frequency (MHz)	Reading (dBuV)	Correct Factor (dB/m)	Result (dBuV/m)	Limit (dBuV/m)	Margin (dB)	Remark
11390.000	44.16	16.09	60.25	74.00	-13.75	peak
11390.000	32.19	16.09	48.28	54.00	-5.72	AVG
N/A						

Remark:

1. Measuring frequencies from 1 GHz to the 10th harmonic of highest fundamental frequency.
2. For above 1GHz, the EUT peak value was under average limit, therefore the Average value compliance with the average limit

Test Mode	IEEE 802.11n HT20 / 5700 MHz	Temp/Hum	24(°C)/ 33%RH
Test Item	Harmonic	Test Date	November 30, 2017
Polarize	Horizontal	Test Engineer	Jerry Chuang
Detector	Peak and Average	Test Voltage	120Vac / 60Hz

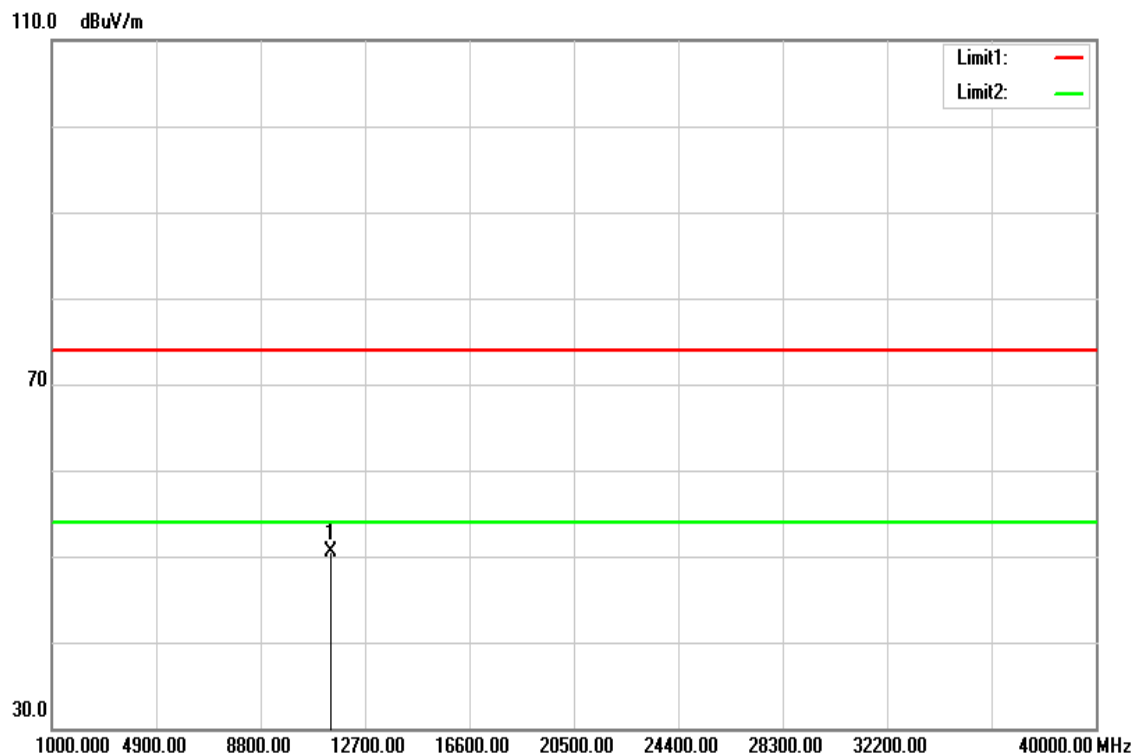

Frequency (MHz)	Reading (dBuV)	Correct Factor (dB/m)	Result (dBuV/m)	Limit (dBuV/m)	Margin (dB)	Remark
11400.000	34.52	16.08	50.60	74.00	-23.40	peak
N/A						

Remark:

1. Measuring frequencies from 1 GHz to the 10th harmonic of highest fundamental frequency.
2. For above 1GHz, the EUT peak value was under average limit, therefore the Average value compliance with the average limit

Test Mode	IEEE 802.11n HT20 / 5720 MHz	Temp/Hum	24(°C)/ 33%RH
Test Item	Harmonic	Test Date	November 30, 2017
Polarize	Vertical	Test Engineer	Jerry Chuang
Detector	Peak and Average	Test Voltage	120Vac / 60Hz

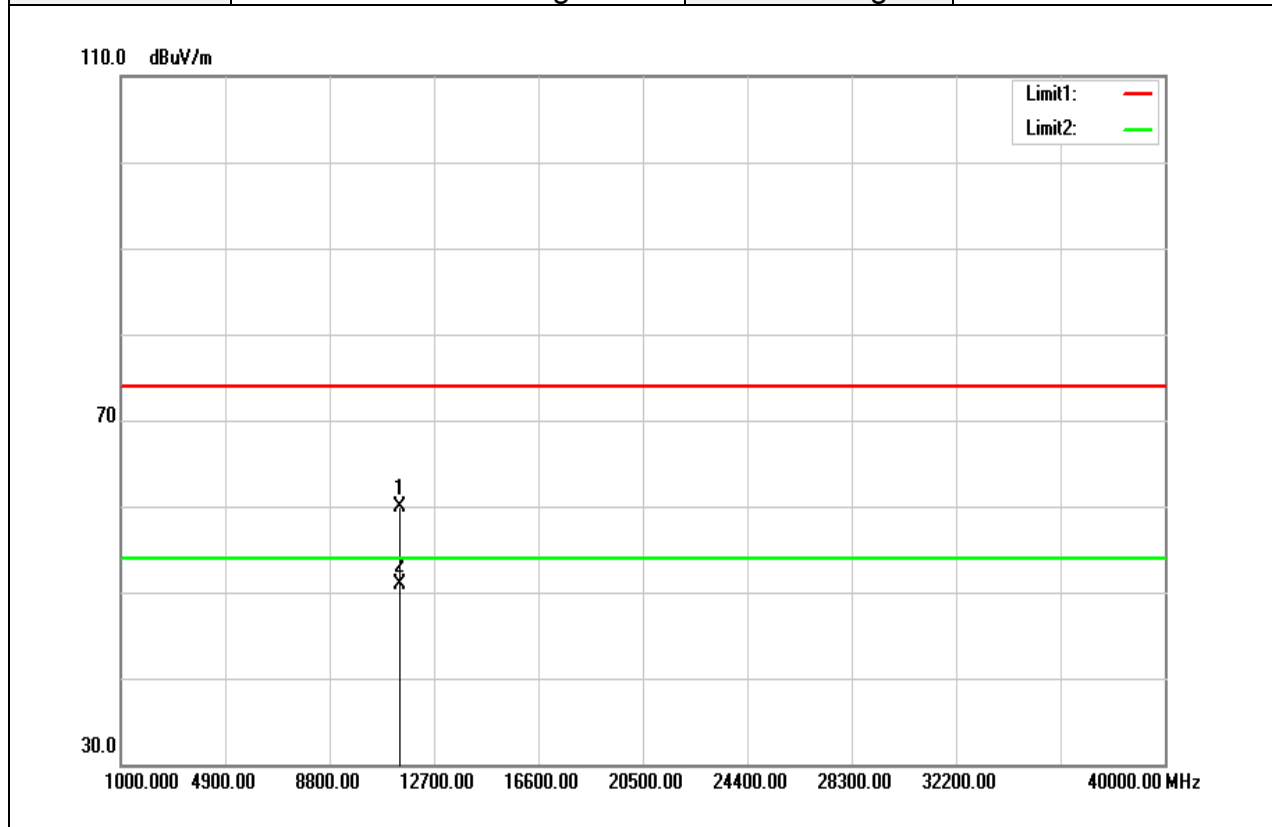

Frequency (MHz)	Reading (dBuV)	Correct Factor (dB/m)	Result (dBuV/m)	Limit (dBuV/m)	Margin (dB)	Remark
11440.000	43.72	16.09	59.81	74.00	-14.19	peak
11440.000	34.80	16.09	50.89	54.00	-3.11	AVG
N/A						

Remark:

1. Measuring frequencies from 1 GHz to the 10th harmonic of highest fundamental frequency.
2. For above 1GHz, the EUT peak value was under average limit, therefore the Average value compliance with the average limit

Test Mode	IEEE 802.11n HT20 / 5720 MHz	Temp/Hum	24(°C)/ 33%RH
Test Item	Harmonic	Test Date	November 30, 2017
Polarize	Horizontal	Test Engineer	Jerry Chuang
Detector	Peak and Average	Test Voltage	120Vac / 60Hz

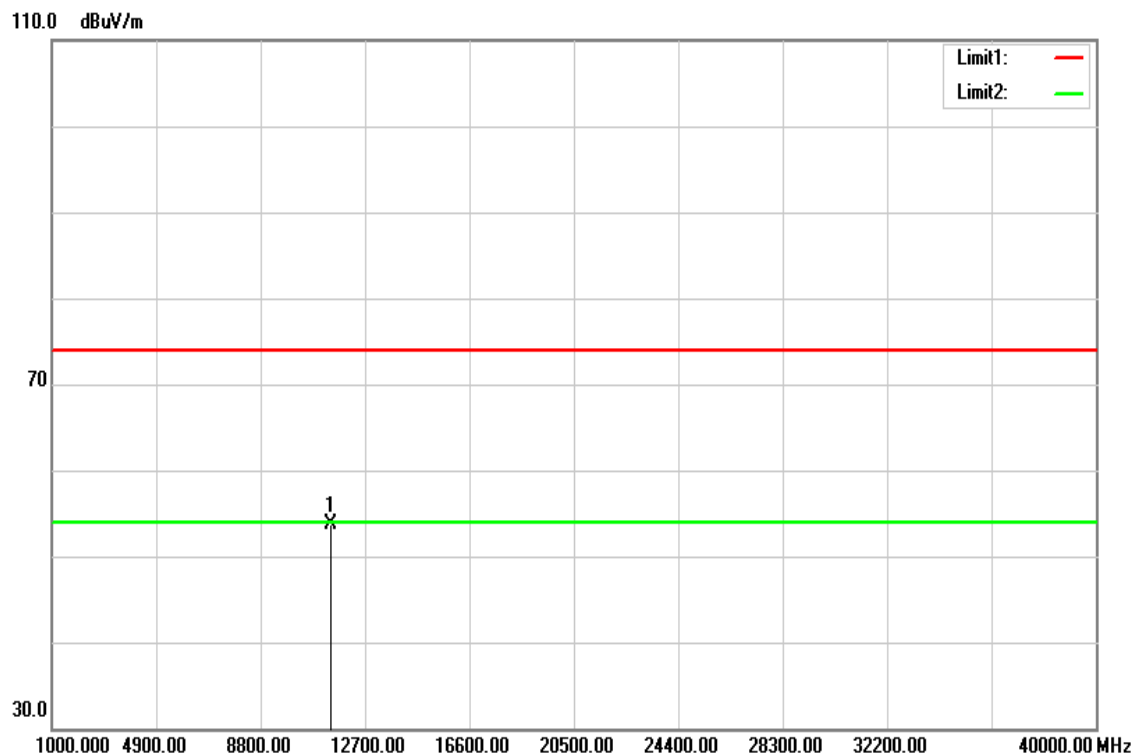

Frequency (MHz)	Reading (dBuV)	Correct Factor (dB/m)	Result (dBuV/m)	Limit (dBuV/m)	Margin (dB)	Remark
11440.000	37.64	16.09	53.73	74.00	-20.27	peak
N/A						

Remark:

1. Measuring frequencies from 1 GHz to the 10th harmonic of highest fundamental frequency.
2. For above 1GHz, the EUT peak value was under average limit, therefore the Average value compliance with the average limit

Test Mode	IEEE 802.11n HT40 / 5510 MHz	Temp/Hum	24(°C)/ 33%RH
Test Item	Harmonic	Test Date	November 30, 2017
Polarize	Vertical	Test Engineer	Jerry Chuang
Detector	Peak and Average	Test Voltage	120Vac / 60Hz

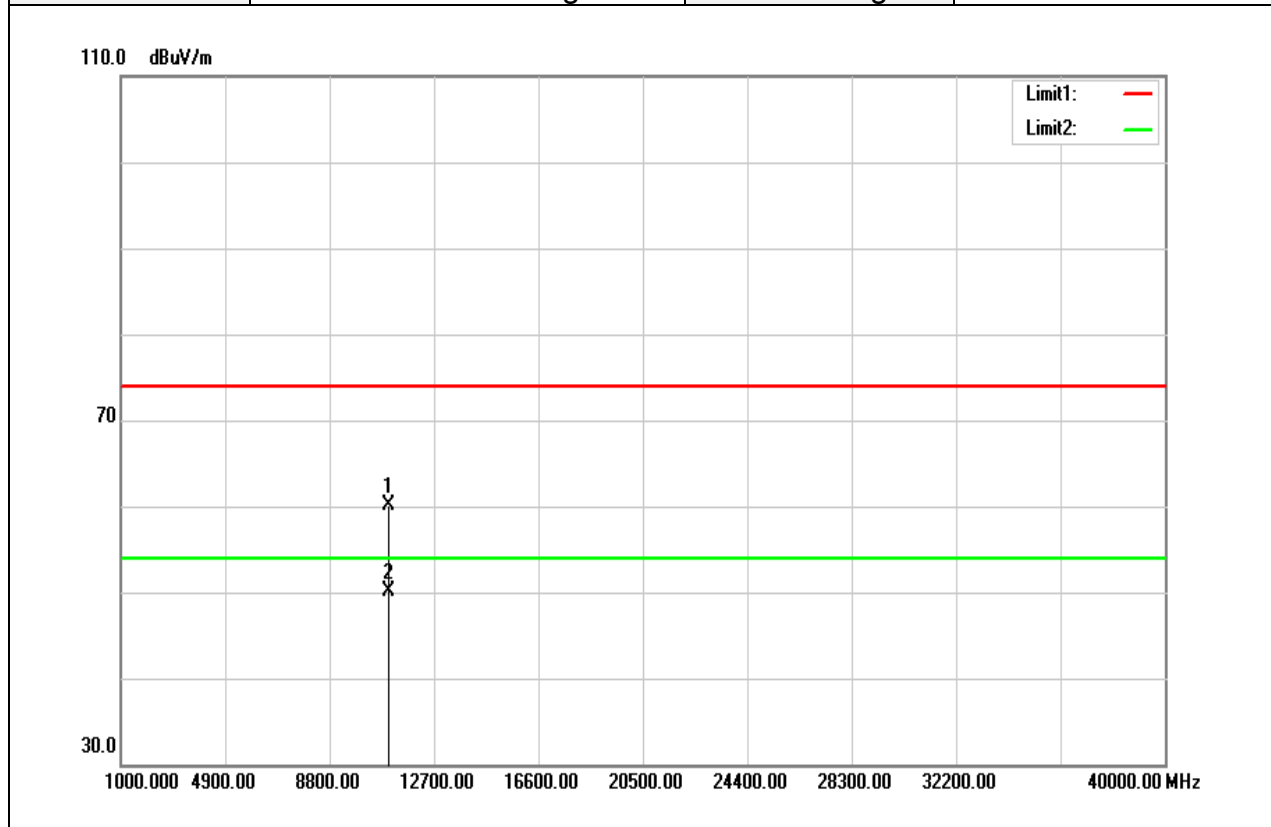

Frequency (MHz)	Reading (dBuV)	Correct Factor (dB/m)	Result (dBuV/m)	Limit (dBuV/m)	Margin (dB)	Remark
11020.000	44.11	16.05	60.16	74.00	-13.84	peak
11020.000	34.06	16.05	50.11	54.00	-3.89	AVG
N/A						

Remark:

1. Measuring frequencies from 1 GHz to the 10th harmonic of highest fundamental frequency.
2. For above 1GHz, the EUT peak value was under average limit, therefore the Average value compliance with the average limit

Test Mode	IEEE 802.11n HT40 / 5510 MHz	Temp/Hum	24(°C)/ 33%RH
Test Item	Harmonic	Test Date	November 30, 2017
Polarize	Horizontal	Test Engineer	Jerry Chuang
Detector	Peak and Average	Test Voltage	120Vac / 60Hz

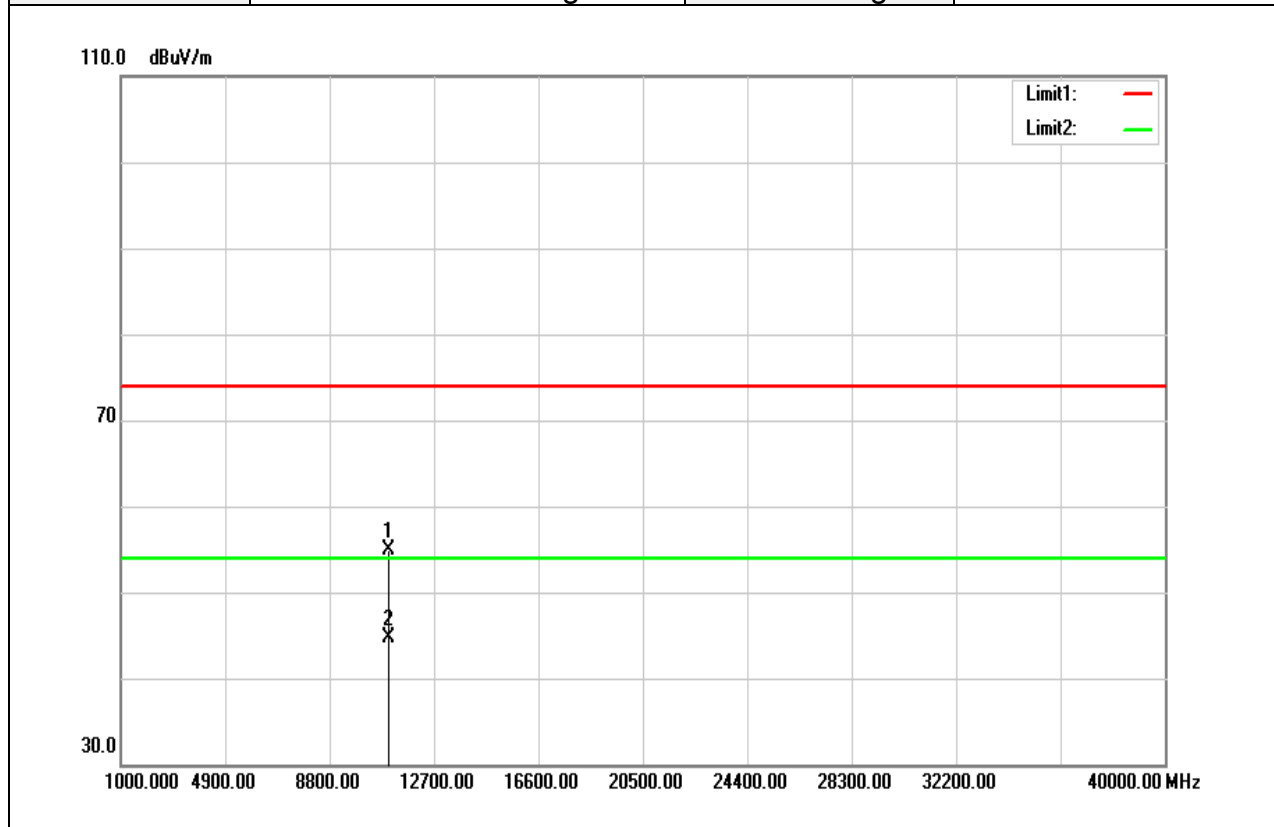

Frequency (MHz)	Reading (dBuV)	Correct Factor (dB/m)	Result (dBuV/m)	Limit (dBuV/m)	Margin (dB)	Remark
11020.000	38.77	16.05	54.82	74.00	-19.18	peak
11020.000	28.58	16.05	44.63	54.00	-9.37	AVG
N/A						

Remark:

1. Measuring frequencies from 1 GHz to the 10th harmonic of highest fundamental frequency.
2. For above 1GHz, the EUT peak value was under average limit, therefore the Average value compliance with the average limit

Test Mode	IEEE 802.11n HT40 / 5550 MHz	Temp/Hum	24(°C)/ 33%RH
Test Item	Harmonic	Test Date	November 30, 2017
Polarize	Vertical	Test Engineer	Jerry Chuang
Detector	Peak and Average	Test Voltage	120Vac / 60Hz

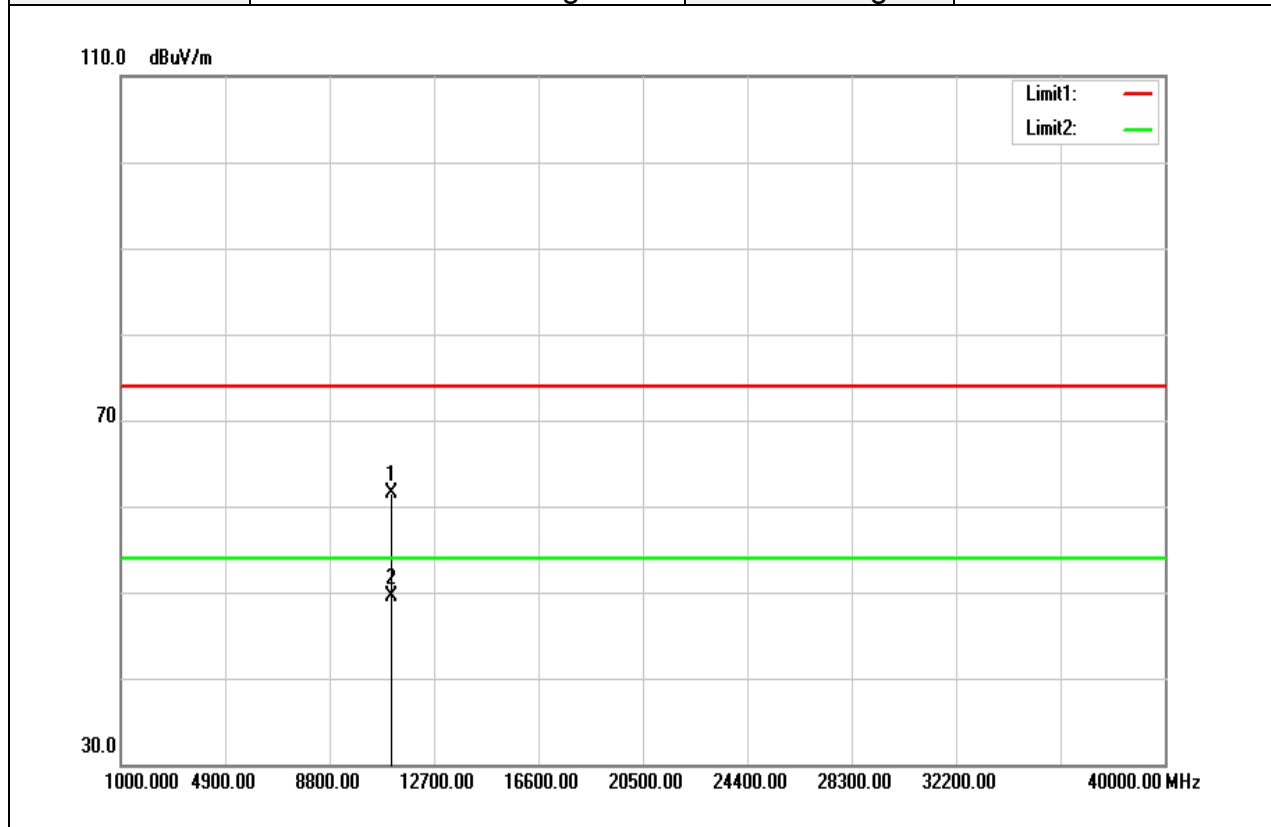

Frequency (MHz)	Reading (dBuV)	Correct Factor (dB/m)	Result (dBuV/m)	Limit (dBuV/m)	Margin (dB)	Remark
11090.000	45.47	16.07	61.54	74.00	-12.46	peak
11090.000	33.35	16.07	49.42	54.00	-4.58	AVG
N/A						

Remark:

1. Measuring frequencies from 1 GHz to the 10th harmonic of highest fundamental frequency.
2. For above 1GHz, the EUT peak value was under average limit, therefore the Average value compliance with the average limit

Test Mode	IEEE 802.11n HT40 / 5550 MHz	Temp/Hum	24(°C)/ 33%RH
Test Item	Harmonic	Test Date	November 30, 2017
Polarize	Horizontal	Test Engineer	Jerry Chuang
Detector	Peak and Average	Test Voltage	120Vac / 60Hz

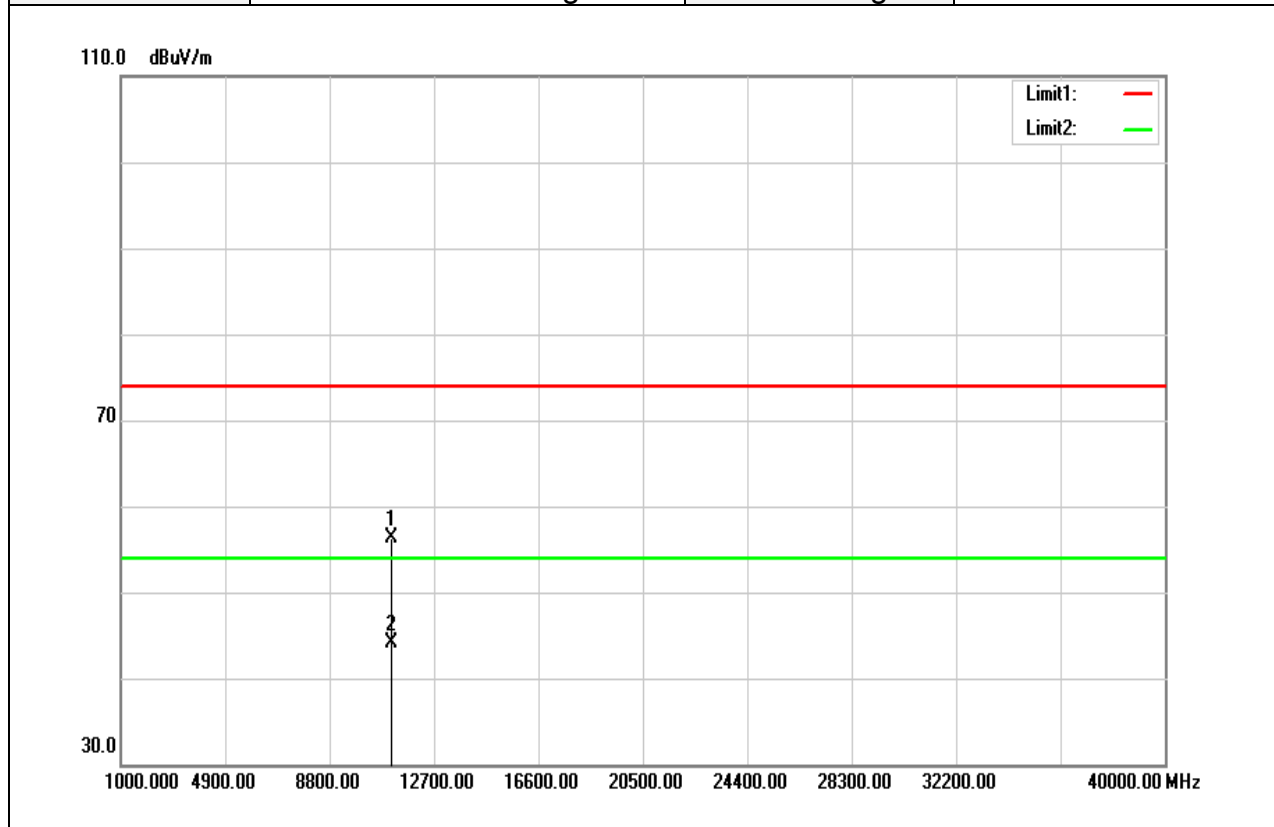

Frequency (MHz)	Reading (dBuV)	Correct Factor (dB/m)	Result (dBuV/m)	Limit (dBuV/m)	Margin (dB)	Remark
11110.000	40.15	16.06	56.21	74.00	-17.79	peak
11110.000	28.00	16.06	44.06	54.00	-9.94	AVG
N/A						

Remark:

1. Measuring frequencies from 1 GHz to the 10th harmonic of highest fundamental frequency.
2. For above 1GHz, the EUT peak value was under average limit, therefore the Average value compliance with the average limit

Test Mode	IEEE 802.11n HT40 / 5670 MHz	Temp/Hum	24(°C)/ 33%RH
Test Item	Harmonic	Test Date	November 30, 2017
Polarize	Vertical	Test Engineer	Jerry Chuang
Detector	Peak and Average	Test Voltage	120Vac / 60Hz

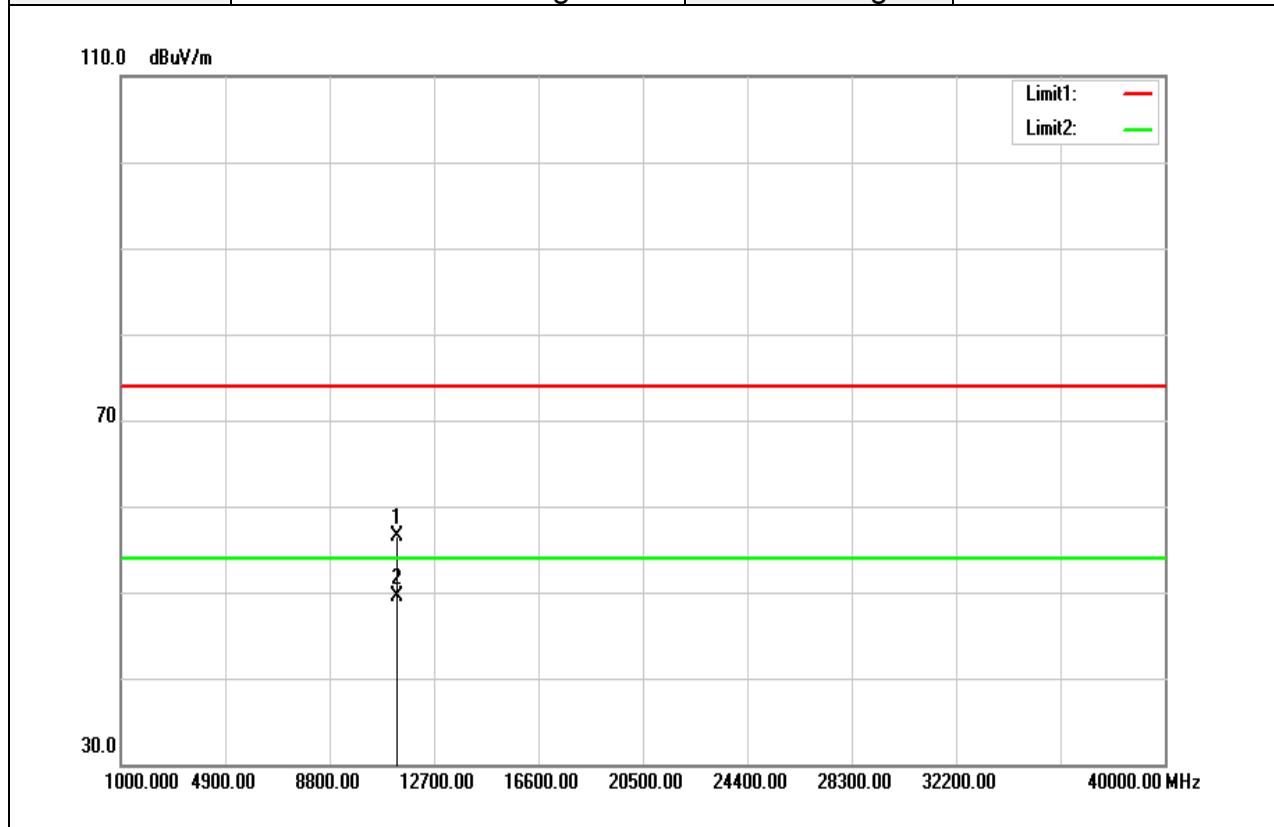

Frequency (MHz)	Reading (dBuV)	Correct Factor (dB/m)	Result (dBuV/m)	Limit (dBuV/m)	Margin (dB)	Remark
11340.000	40.49	16.08	56.57	74.00	-17.43	peak
11340.000	33.52	16.08	49.60	54.00	-4.40	AVG
N/A						

Remark:

1. Measuring frequencies from 1 GHz to the 10th harmonic of highest fundamental frequency.
2. For above 1GHz, the EUT peak value was under average limit, therefore the Average value compliance with the average limit

Test Mode	IEEE 802.11n HT40 / 5670 MHz	Temp/Hum	24(°C)/ 33%RH
Test Item	Harmonic	Test Date	November 30, 2017
Polarize	Horizontal	Test Engineer	Jerry Chuang
Detector	Peak and Average	Test Voltage	120Vac / 60Hz

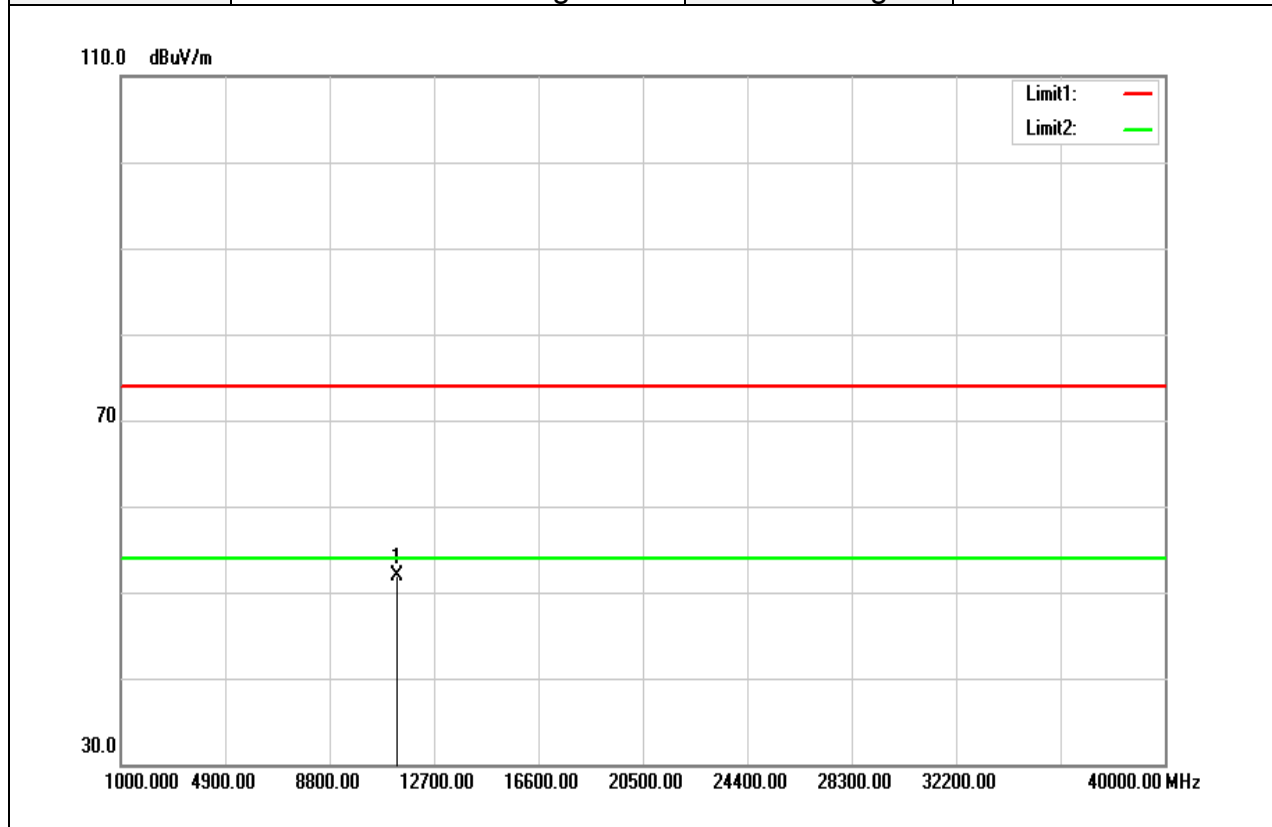

Frequency (MHz)	Reading (dBuV)	Correct Factor (dB/m)	Result (dBuV/m)	Limit (dBuV/m)	Margin (dB)	Remark
11340.000	35.73	16.08	51.81	74.00	-22.19	peak
N/A						

Remark:

1. Measuring frequencies from 1 GHz to the 10th harmonic of highest fundamental frequency.
2. For above 1GHz, the EUT peak value was under average limit, therefore the Average value compliance with the average limit

Test Mode	IEEE 802.11n HT40 / 5710 MHz	Temp/Hum	24(°C)/ 33%RH
Test Item	Harmonic	Test Date	November 30, 2017
Polarize	Vertical	Test Engineer	Jerry Chuang
Detector	Peak and Average	Test Voltage	120Vac / 60Hz

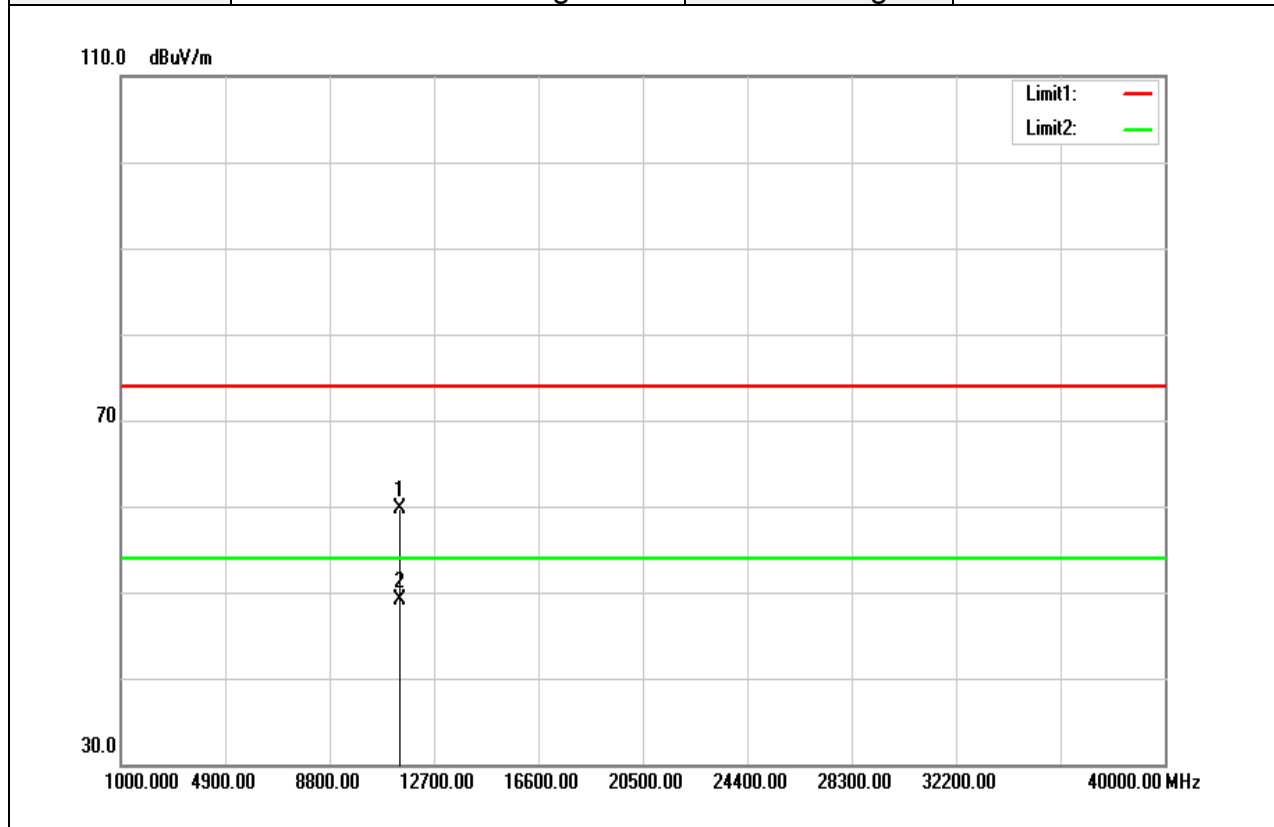

Frequency (MHz)	Reading (dBuV)	Correct Factor (dB/m)	Result (dBuV/m)	Limit (dBuV/m)	Margin (dB)	Remark
11420.000	43.69	16.08	59.77	74.00	-14.23	peak
11420.000	32.94	16.08	49.02	54.00	-4.98	AVG
N/A						

Remark:

1. Measuring frequencies from 1 GHz to the 10th harmonic of highest fundamental frequency.
2. For above 1GHz, the EUT peak value was under average limit, therefore the Average value compliance with the average limit

Test Mode	IEEE 802.11n HT40 / 5710 MHz	Temp/Hum	24(°C)/ 33%RH
Test Item	Harmonic	Test Date	November 30, 2017
Polarize	Horizontal	Test Engineer	Jerry Chuang
Detector	Peak and Average	Test Voltage	120Vac / 60Hz

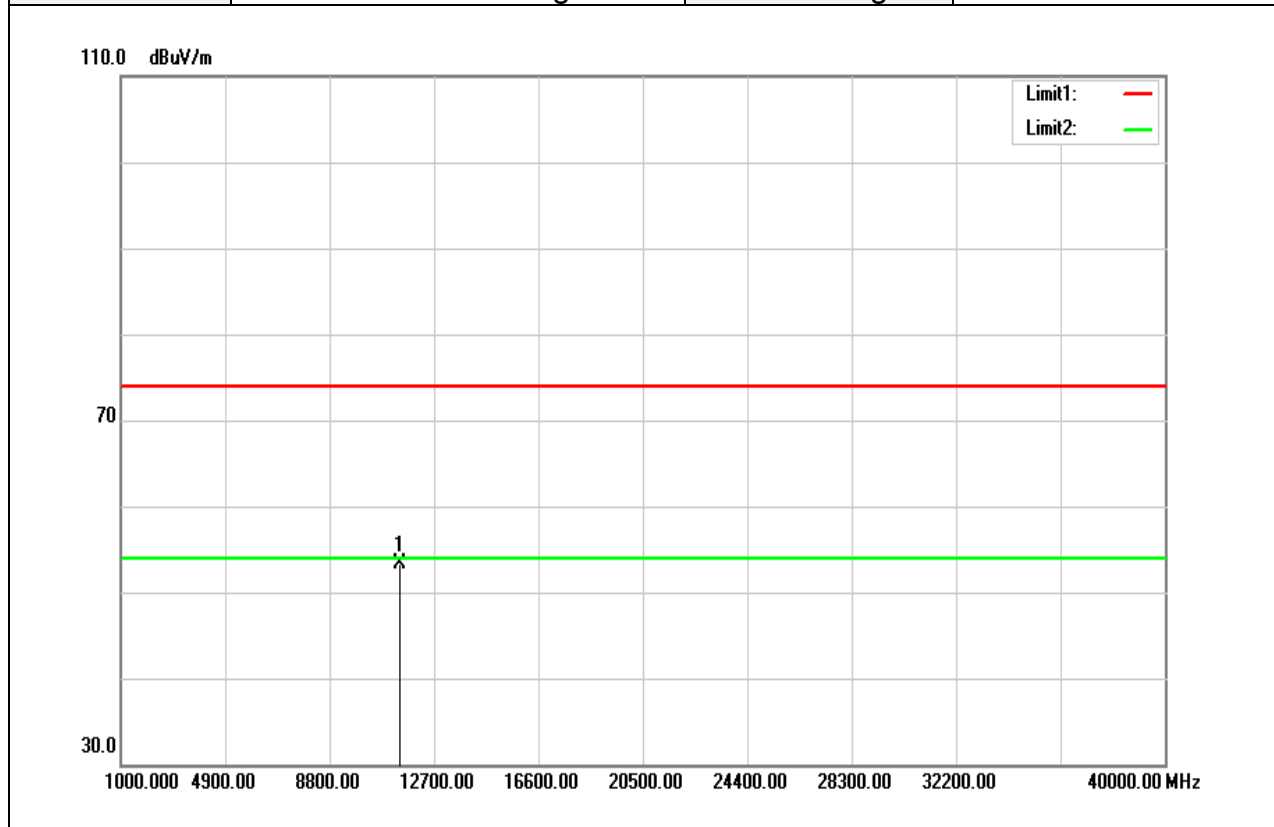

Frequency (MHz)	Reading (dBuV)	Correct Factor (dB/m)	Result (dBuV/m)	Limit (dBuV/m)	Margin (dB)	Remark
11420.000	37.15	16.08	53.23	74.00	-20.77	peak
N/A						

Remark:

1. Measuring frequencies from 1 GHz to the 10th harmonic of highest fundamental frequency.
2. For above 1GHz, the EUT peak value was under average limit, therefore the Average value compliance with the average limit

Test Mode	IEEE 802.11ac VHT80 / 5530 MHz	Temp/Hum	24(°C)/ 33%RH
Test Item	Harmonic	Test Date	November 30, 2017
Polarize	Vertical	Test Engineer	Jerry Chuang
Detector	Peak and Average	Test Voltage	120Vac / 60Hz

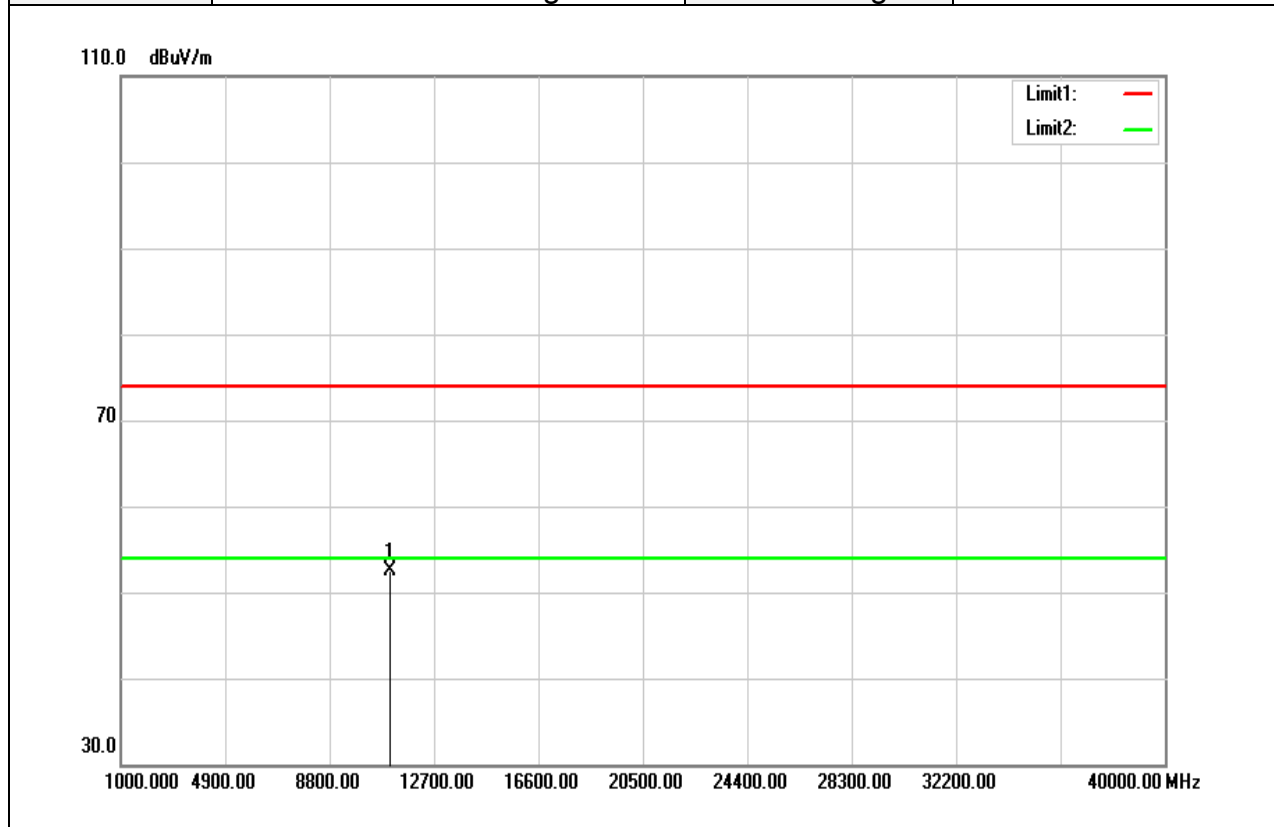

Frequency (MHz)	Reading (dBuV)	Correct Factor (dB/m)	Result (dBuV/m)	Limit (dBuV/m)	Margin (dB)	Remark
11060.000	36.41	16.06	52.47	74.00	-21.53	peak
N/A						

Remark:

1. Measuring frequencies from 1 GHz to the 10th harmonic of highest fundamental frequency.
2. For above 1GHz, the EUT peak value was under average limit, therefore the Average value compliance with the average limit

Test Mode	IEEE 802.11ac VHT80 / 5530 MHz	Temp/Hum	24(°C)/ 33%RH
Test Item	Harmonic	Test Date	November 30, 2017
Polarize	Horizontal	Test Engineer	Jerry Chuang
Detector	Peak and Average	Test Voltage	120Vac / 60Hz

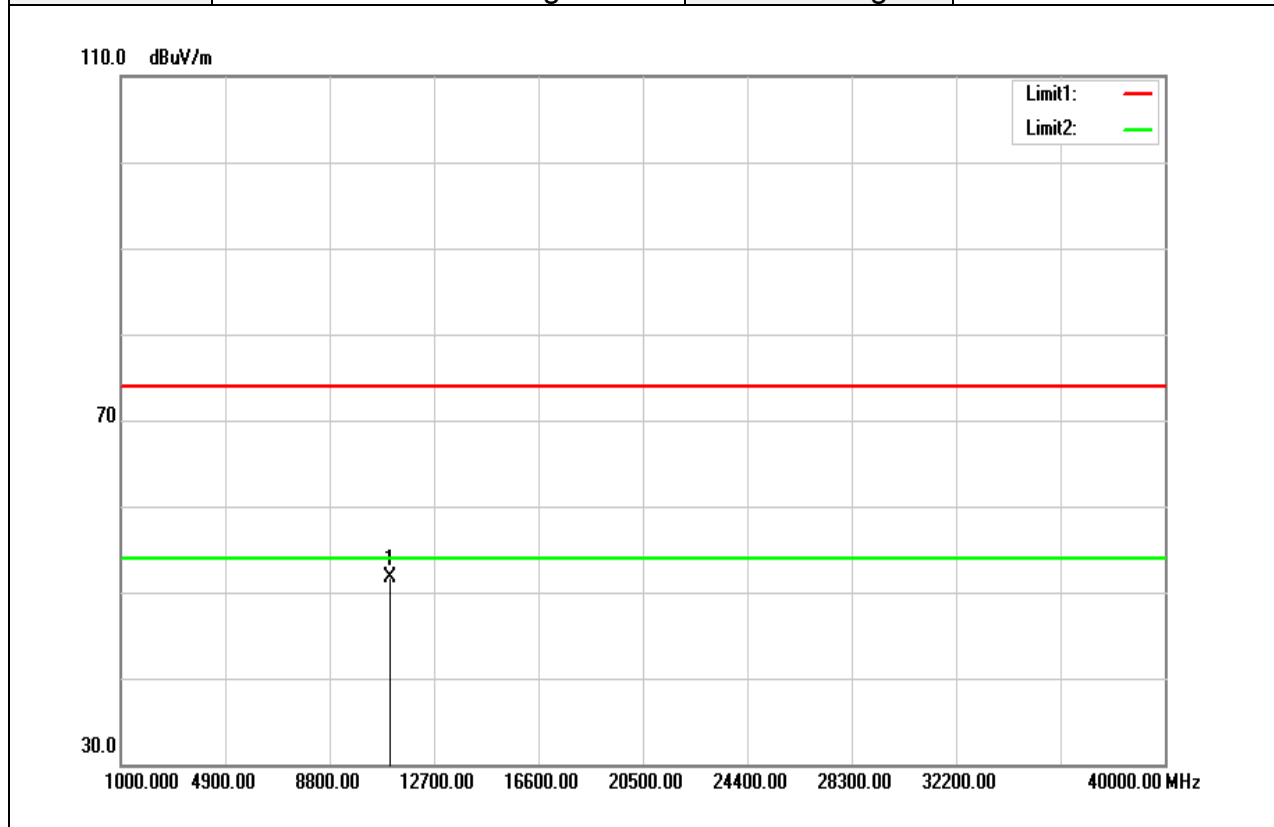

Frequency (MHz)	Reading (dBuV)	Correct Factor (dB/m)	Result (dBuV/m)	Limit (dBuV/m)	Margin (dB)	Remark
11060.000	35.55	16.06	51.61	74.00	-22.39	peak
N/A						

Remark:

1. Measuring frequencies from 1 GHz to the 10th harmonic of highest fundamental frequency.
2. For above 1GHz, the EUT peak value was under average limit, therefore the Average value compliance with the average limit

Test Mode	IEEE 802.11ac VHT80 / 5690 MHz	Temp/Hum	24(°C)/ 33%RH
Test Item	Harmonic	Test Date	November 30, 2017
Polarize	Vertical	Test Engineer	Jerry Chuang
Detector	Peak and Average	Test Voltage	120Vac / 60Hz

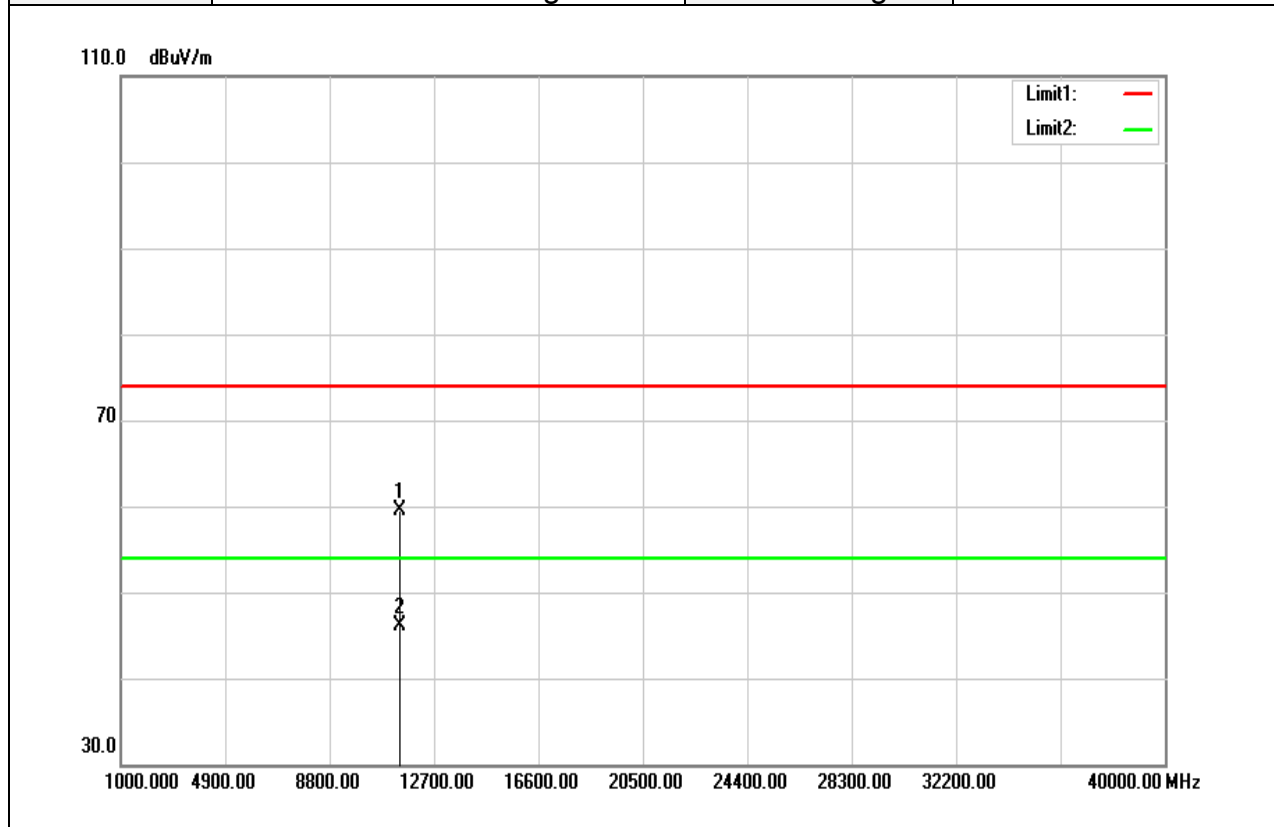

Frequency (MHz)	Reading (dBuV)	Correct Factor (dB/m)	Result (dBuV/m)	Limit (dBuV/m)	Margin (dB)	Remark
11400.000	43.36	16.08	59.44	74.00	-14.56	peak
11400.000	30.11	16.08	46.19	54.00	-7.81	AVG
N/A						

Remark:

1. Measuring frequencies from 1 GHz to the 10th harmonic of highest fundamental frequency.
2. For above 1GHz, the EUT peak value was under average limit, therefore the Average value compliance with the average limit

Test Mode	IEEE 802.11ac VHT80 / 5690 MHz	Temp/Hum	24(°C)/ 33%RH
Test Item	Harmonic	Test Date	November 30, 2017
Polarize	Horizontal	Test Engineer	Jerry Chuang
Detector	Peak and Average	Test Voltage	120Vac / 60Hz

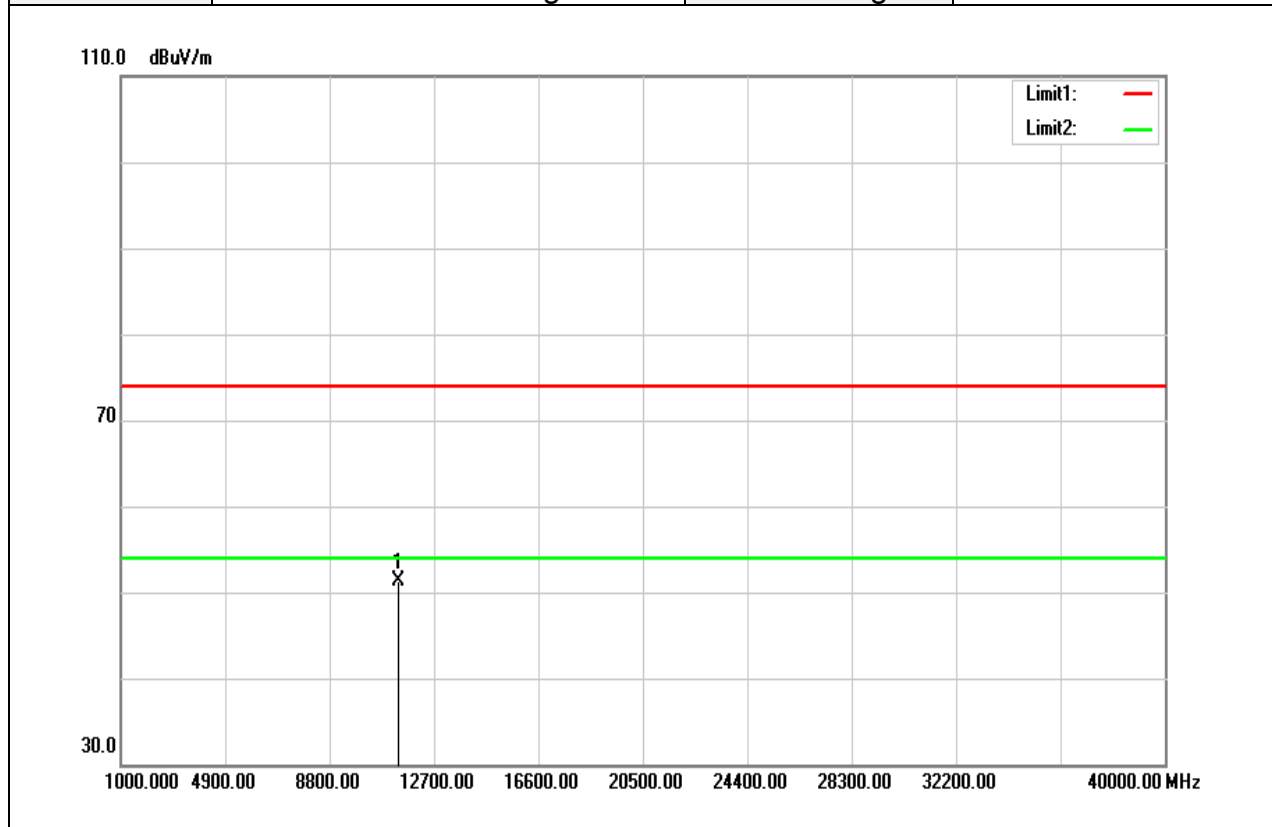

Frequency (MHz)	Reading (dBuV)	Correct Factor (dB/m)	Result (dBuV/m)	Limit (dBuV/m)	Margin (dB)	Remark
11380.000	35.26	16.09	51.35	74.00	-22.65	peak
N/A						

Remark:

1. Measuring frequencies from 1 GHz to the 10th harmonic of highest fundamental frequency.
2. For above 1GHz, the EUT peak value was under average limit, therefore the Average value compliance with the average limit

Above 1G Test Data for UNII-3

Test Mode	IEEE 802.11a / 5745 MHz	Temp/Hum	24(°C)/ 33%RH
Test Item	Harmonic	Test Date	November 30, 2017
Polarize	Vertical	Test Engineer	Jerry Chuang
Detector	Peak and Average	Test Voltage	120Vac / 60Hz

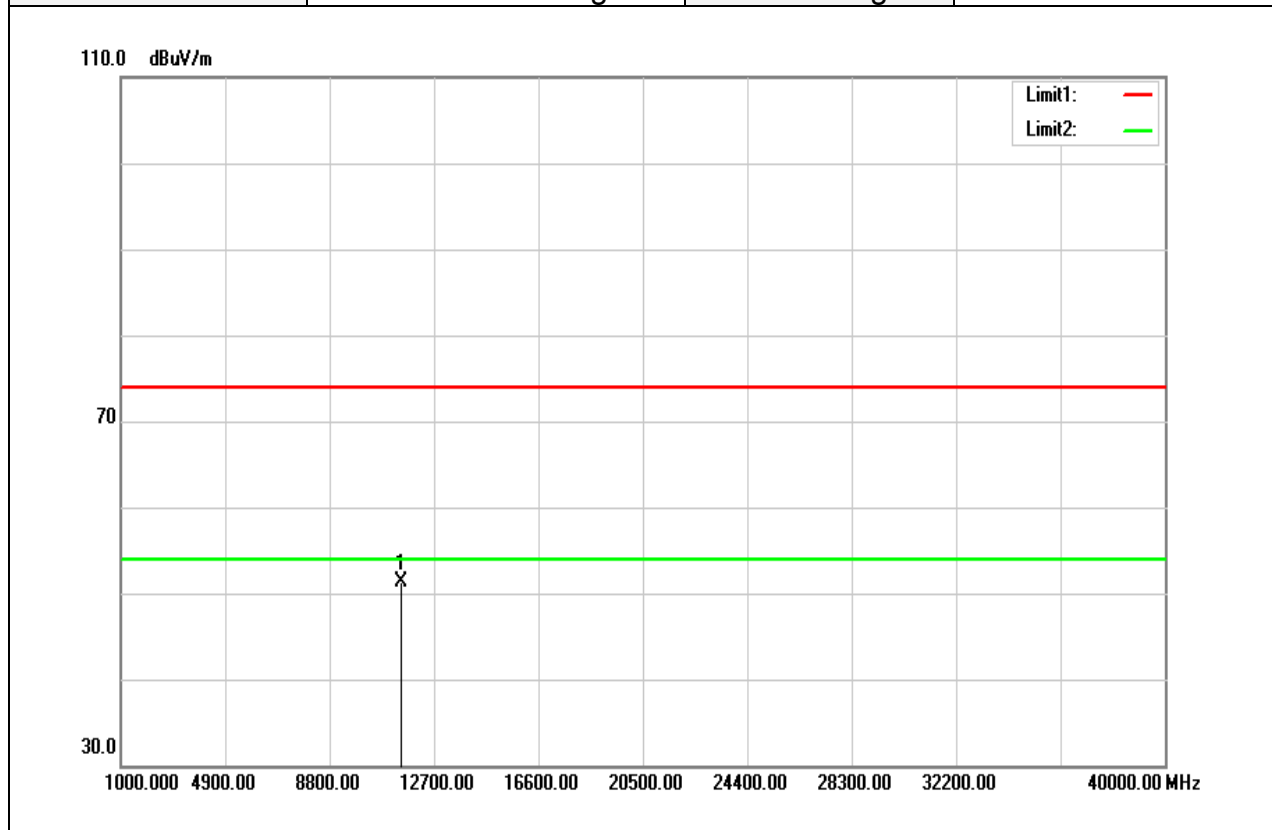

Frequency (MHz)	Reading (dBuV)	Correct Factor (dB/m)	Result (dBuV/m)	Limit (dBuV/m)	Margin (dB)	Remark
11490.000	35.13	16.09	51.22	74.00	-22.78	peak
N/A						

Remark:

1. Measuring frequencies from 1 GHz to the 10th harmonic of highest fundamental frequency.
2. For above 1GHz, the EUT peak value was under average limit, therefore the Average value compliance with the average limit

Test Mode	IEEE 802.11a / 5745 MHz	Temp/Hum	24(°C)/ 33%RH
Test Item	Harmonic	Test Date	November 30, 2017
Polarize	Horizontal	Test Engineer	Jerry Chuang
Detector	Peak and Average	Test Voltage	120Vac / 60Hz

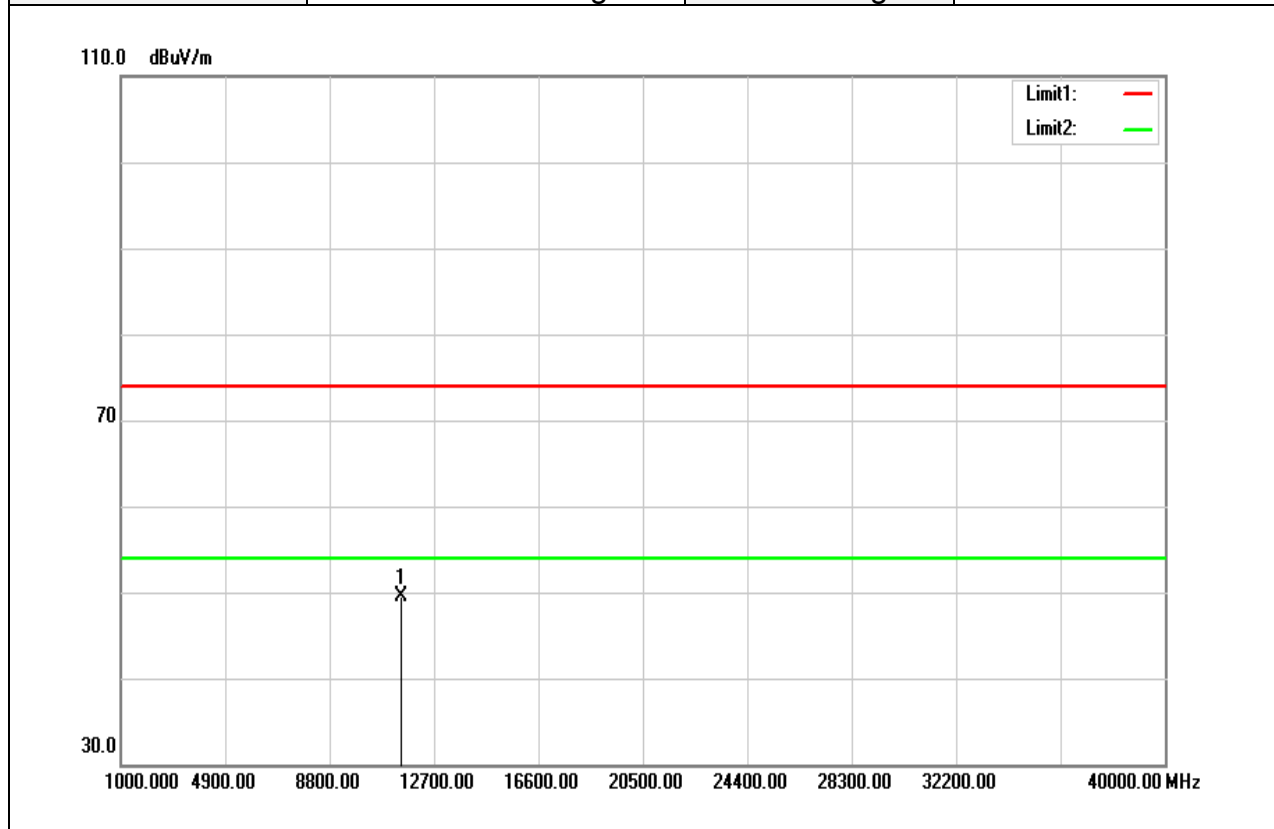

Frequency (MHz)	Reading (dBuV)	Correct Factor (dB/m)	Result (dBuV/m)	Limit (dBuV/m)	Margin (dB)	Remark
11490.000	33.47	16.09	49.56	74.00	-24.44	peak
N/A						

Remark:

1. Measuring frequencies from 1 GHz to the 10th harmonic of highest fundamental frequency.
2. For above 1GHz, the EUT peak value was under average limit, therefore the Average value compliance with the average limit

Test Mode	IEEE 802.11a / 5745 MHz	Temp/Hum	24(°C)/ 33%RH
Test Item	Harmonic	Test Date	November 30, 2017
Polarize	Vertical	Test Engineer	Jerry Chuang
Detector	Peak and Average	Test Voltage	120Vac / 60Hz

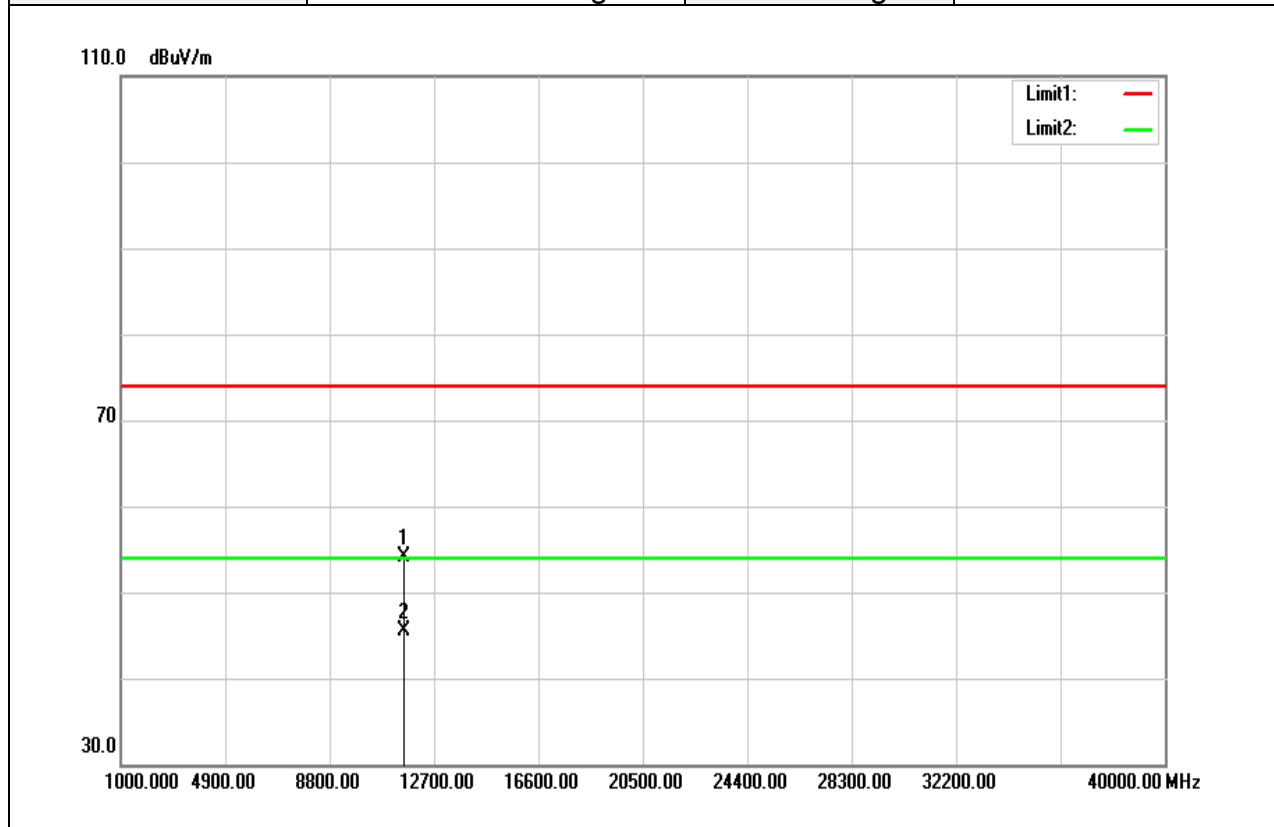

Frequency (MHz)	Reading (dBuV)	Correct Factor (dB/m)	Result (dBuV/m)	Limit (dBuV/m)	Margin (dB)	Remark
11570.000	38.06	16.01	54.07	74.00	-19.93	peak
11570.000	29.54	16.01	45.55	74.00	-28.45	peak
N/A						

Remark:

1. Measuring frequencies from 1 GHz to the 10th harmonic of highest fundamental frequency.
2. For above 1GHz, the EUT peak value was under average limit, therefore the Average value compliance with the average limit

Test Mode	IEEE 802.11a / 5745 MHz	Temp/Hum	24(°C)/ 33%RH
Test Item	Harmonic	Test Date	November 30, 2017
Polarize	Horizontal	Test Engineer	Jerry Chuang
Detector	Peak and Average	Test Voltage	120Vac / 60Hz

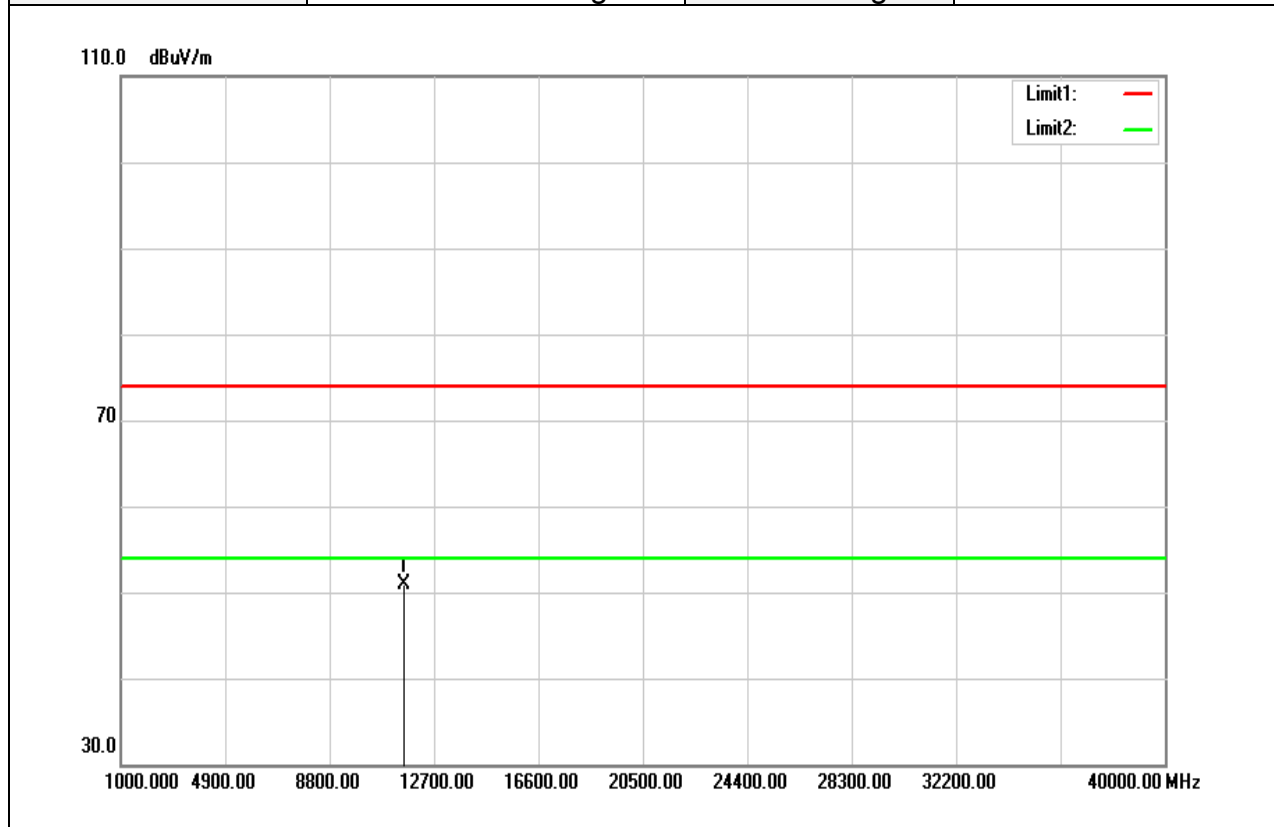

Frequency (MHz)	Reading (dBuV)	Correct Factor (dB/m)	Result (dBuV/m)	Limit (dBuV/m)	Margin (dB)	Remark
11570.000	34.90	16.01	50.91	74.00	-23.09	peak
N/A						

Remark:

1. Measuring frequencies from 1 GHz to the 10th harmonic of highest fundamental frequency.
2. For above 1GHz, the EUT peak value was under average limit, therefore the Average value compliance with the average limit

Test Mode	IEEE 802.11a / 5825 MHz	Temp/Hum	24(°C)/ 33%RH
Test Item	Harmonic	Test Date	November 30, 2017
Polarize	Vertical	Test Engineer	Jerry Chuang
Detector	Peak and Average	Test Voltage	120Vac / 60Hz

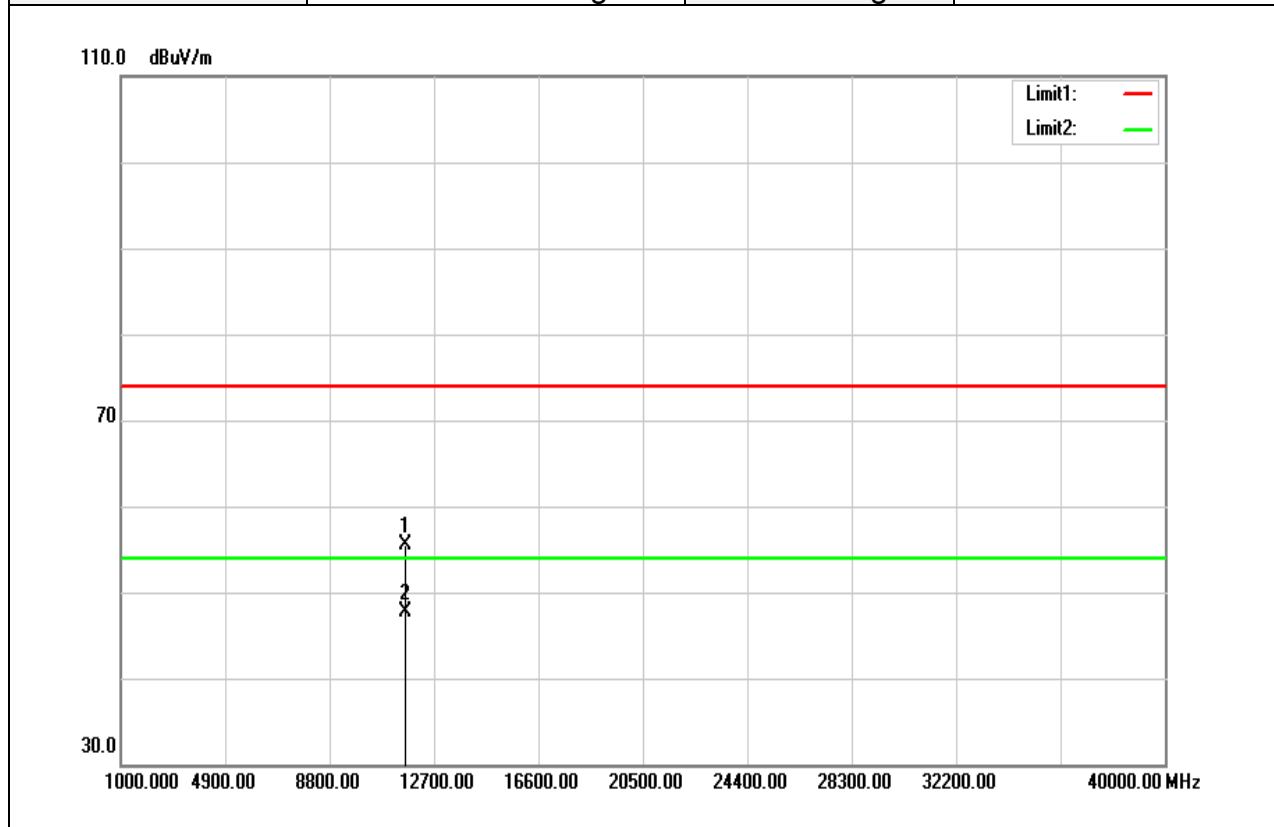

Frequency (MHz)	Reading (dBuV)	Correct Factor (dB/m)	Result (dBuV/m)	Limit (dBuV/m)	Margin (dB)	Remark
11650.000	39.66	15.93	55.59	74.00	-18.41	peak
11650.000	31.70	15.93	47.63	54.00	-6.37	AVG
N/A						

Remark:

1. Measuring frequencies from 1 GHz to the 10th harmonic of highest fundamental frequency.
2. For above 1GHz, the EUT peak value was under average limit, therefore the Average value compliance with the average limit

Test Mode	IEEE 802.11a / 5825 MHz	Temp/Hum	24(°C)/ 33%RH
Test Item	Harmonic	Test Date	November 30, 2017
Polarize	Horizontal	Test Engineer	Jerry Chuang
Detector	Peak and Average	Test Voltage	120Vac / 60Hz

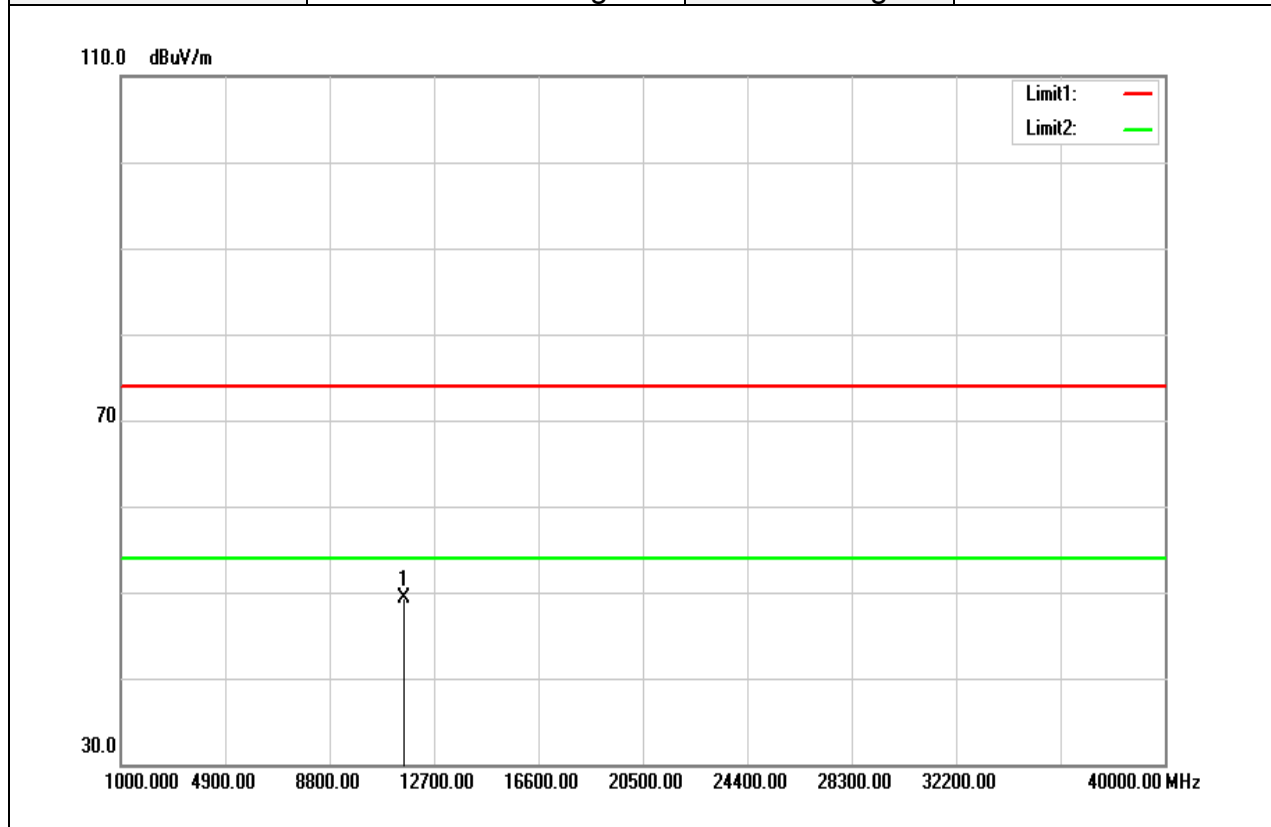

Frequency (MHz)	Reading (dBuV)	Correct Factor (dB/m)	Result (dBuV/m)	Limit (dBuV/m)	Margin (dB)	Remark
11570.000	33.35	16.01	49.36	74.00	-24.64	peak
N/A						

Remark:

1. Measuring frequencies from 1 GHz to the 10th harmonic of highest fundamental frequency.
2. For above 1GHz, the EUT peak value was under average limit, therefore the Average value compliance with the average limit

Test Mode	IEEE 802.11n HT20 / 5745 MHz	Temp/Hum	24(°C)/ 33%RH
Test Item	Harmonic	Test Date	November 30, 2017
Polarize	Vertical	Test Engineer	Jerry Chuang
Detector	Peak and Average	Test Voltage	120Vac / 60Hz

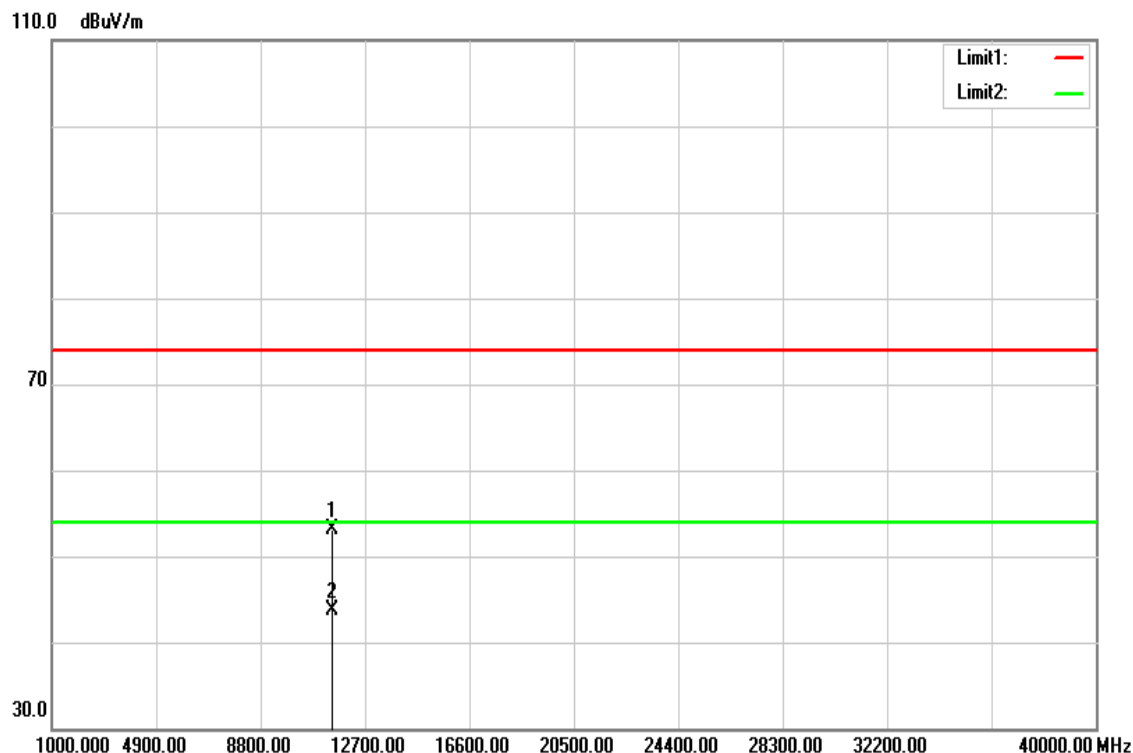

Frequency (MHz)	Reading (dBuV)	Correct Factor (dB/m)	Result (dBuV/m)	Limit (dBuV/m)	Margin (dB)	Remark
11490.000	36.94	16.09	53.03	74.00	-20.97	peak
11490.000	27.58	16.09	43.67	54.00	-10.33	AVG
N/A						

Remark:

1. Measuring frequencies from 1 GHz to the 10th harmonic of highest fundamental frequency.
2. For above 1GHz, the EUT peak value was under average limit, therefore the Average value compliance with the average limit

Test Mode	IEEE 802.11n HT20 / 5745 MHz	Temp/Hum	24(°C)/ 33%RH
Test Item	Harmonic	Test Date	November 30, 2017
Polarize	Horizontal	Test Engineer	Jerry Chuang
Detector	Peak and Average	Test Voltage	120Vac / 60Hz

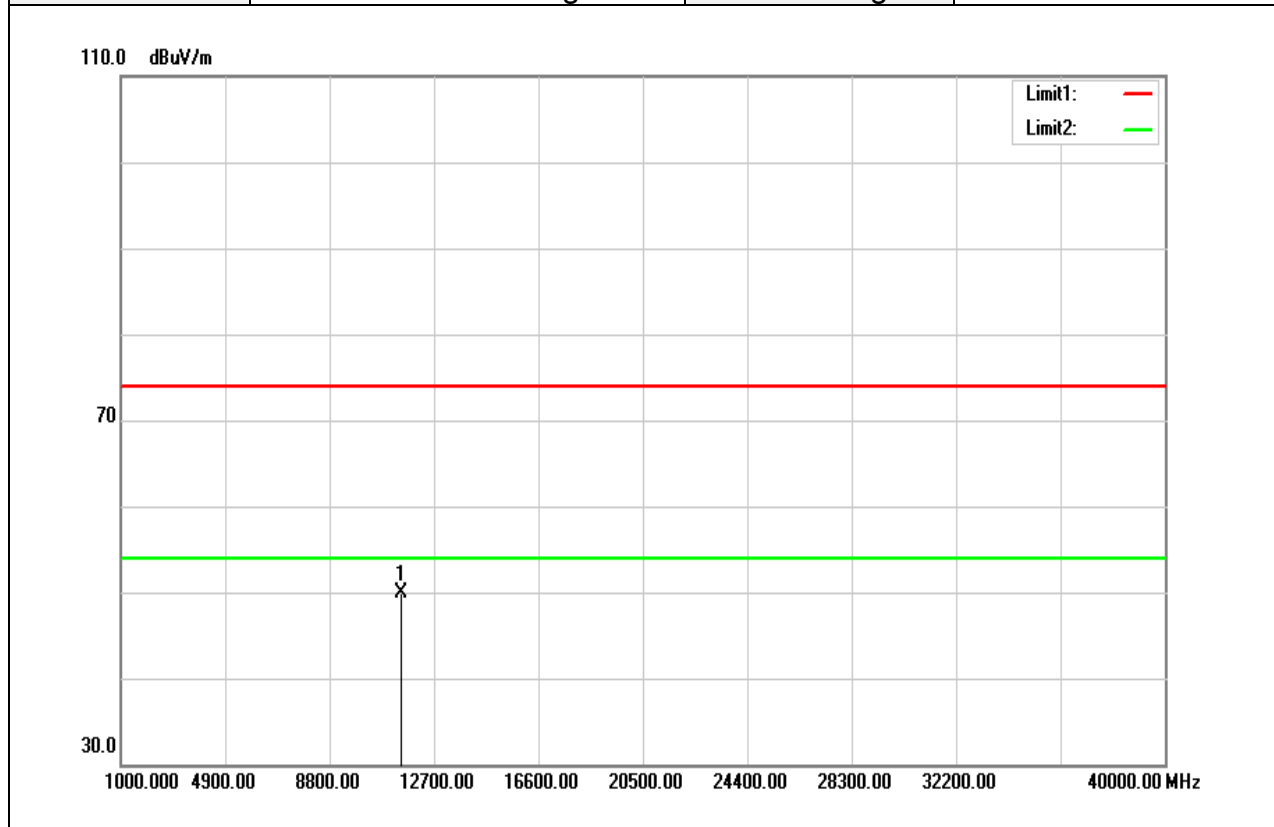

Frequency (MHz)	Reading (dBuV)	Correct Factor (dB/m)	Result (dBuV/m)	Limit (dBuV/m)	Margin (dB)	Remark
11490.000	33.75	16.09	49.84	74.00	-24.16	peak
N/A						

Remark:

1. Measuring frequencies from 1 GHz to the 10th harmonic of highest fundamental frequency.
2. For above 1GHz, the EUT peak value was under average limit, therefore the Average value compliance with the average limit

Test Mode	IEEE 802.11n HT20/ 5785 MHz	Temp/Hum	24(°C)/ 33%RH
Test Item	Harmonic	Test Date	November 30, 2017
Polarize	Vertical	Test Engineer	Jerry Chuang
Detector	Peak and Average	Test Voltage	120Vac / 60Hz

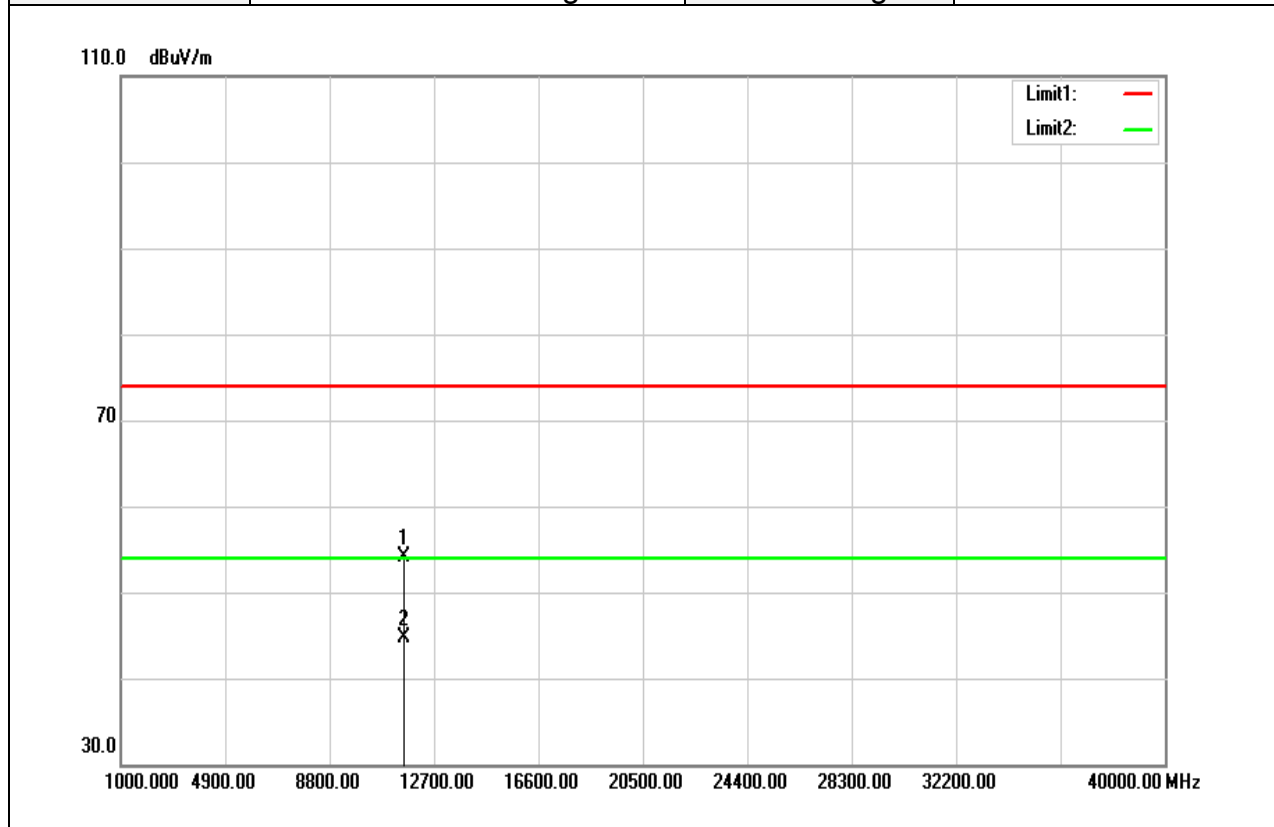

Frequency (MHz)	Reading (dBuV)	Correct Factor (dB/m)	Result (dBuV/m)	Limit (dBuV/m)	Margin (dB)	Remark
11570.000	38.10	16.01	54.11	74.00	-19.89	peak
11570.000	28.63	16.01	44.64	54.00	-9.36	AVG
N/A						

Remark:

1. Measuring frequencies from 1 GHz to the 10th harmonic of highest fundamental frequency.
2. For above 1GHz, the EUT peak value was under average limit, therefore the Average value compliance with the average limit

Test Mode	IEEE 802.11n HT20/ 5785 MHz	Temp/Hum	24(°C)/ 33%RH
Test Item	Harmonic	Test Date	November 30, 2017
Polarize	Horizontal	Test Engineer	Jerry Chuang
Detector	Peak and Average	Test Voltage	120Vac / 60Hz

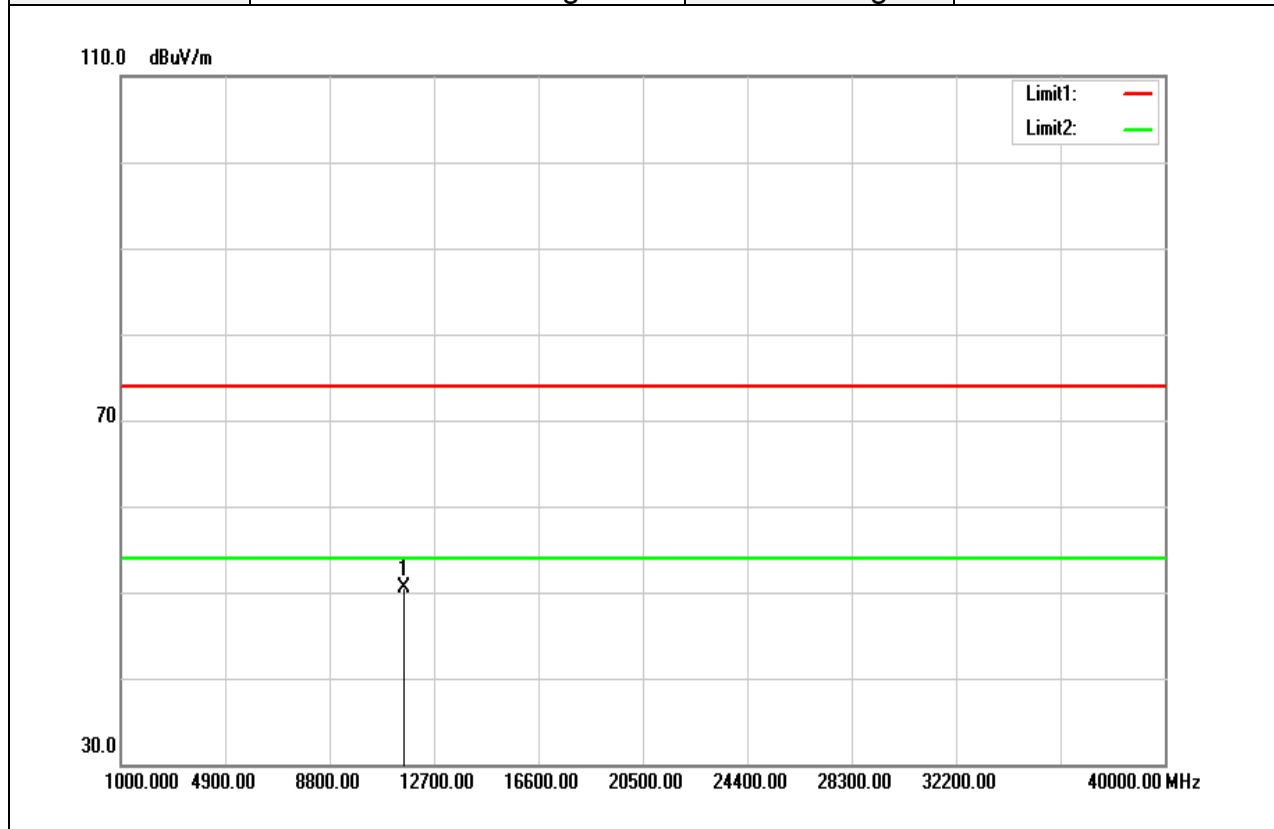

Frequency (MHz)	Reading (dBuV)	Correct Factor (dB/m)	Result (dBuV/m)	Limit (dBuV/m)	Margin (dB)	Remark
11570.000	34.40	16.01	50.41	74.00	-23.59	peak
N/A						

Remark:

1. Measuring frequencies from 1 GHz to the 10th harmonic of highest fundamental frequency.
2. For above 1GHz, the EUT peak value was under average limit, therefore the Average value compliance with the average limit

Test Mode	IEEE 802.11n HT20/ 5825 MHz	Temp/Hum	24(°C)/ 33%RH
Test Item	Harmonic	Test Date	November 30, 2017
Polarize	Vertical	Test Engineer	Jerry Chuang
Detector	Peak and Average	Test Voltage	120Vac / 60Hz

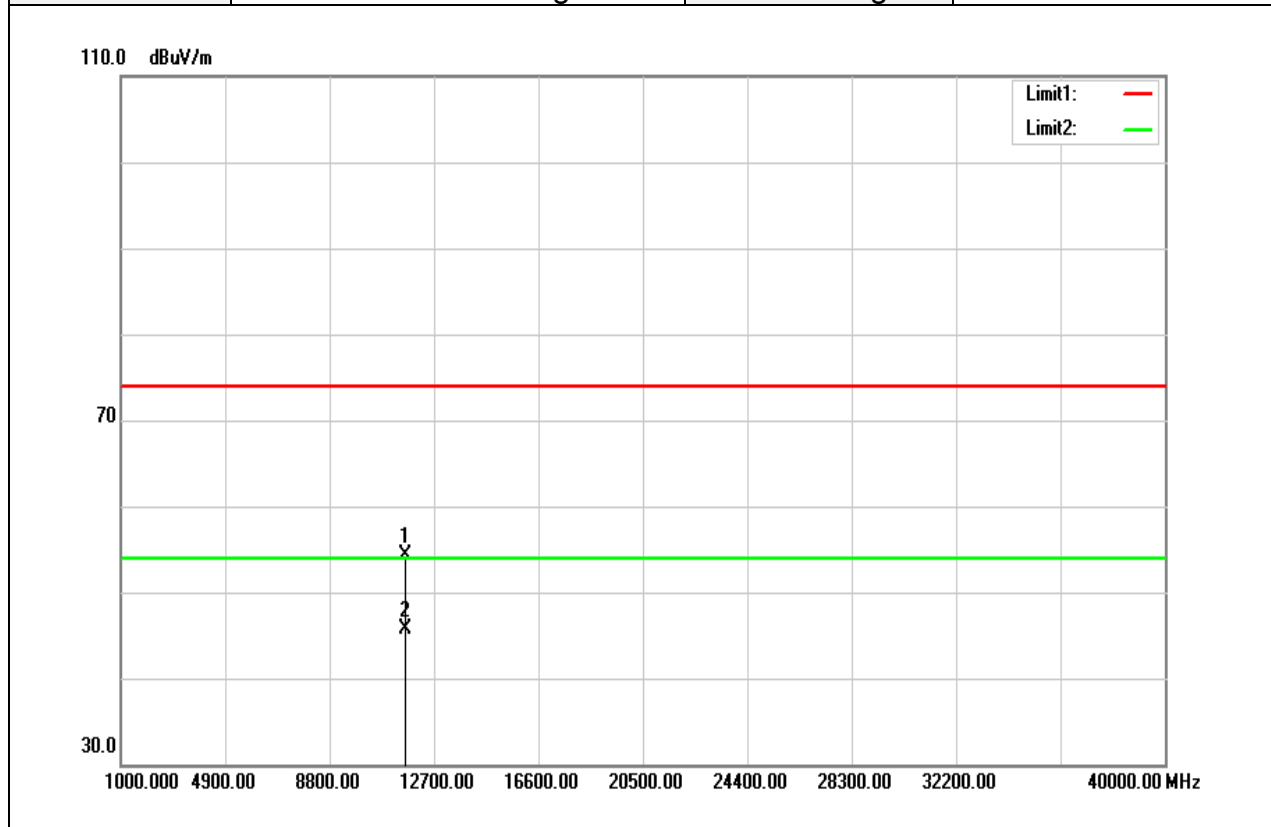

Frequency (MHz)	Reading (dBuV)	Correct Factor (dB/m)	Result (dBuV/m)	Limit (dBuV/m)	Margin (dB)	Remark
11650.000	38.32	15.93	54.25	74.00	-19.75	peak
11650.000	29.71	15.93	45.64	54.00	-8.36	AVG
N/A						

Remark:

1. Measuring frequencies from 1 GHz to the 10th harmonic of highest fundamental frequency.
2. For above 1GHz, the EUT peak value was under average limit, therefore the Average value compliance with the average limit

Test Mode	IEEE 802.11n HT20/ 5825 MHz	Temp/Hum	24(°C)/ 33%RH
Test Item	Harmonic	Test Date	November 30, 2017
Polarize	Horizontal	Test Engineer	Jerry Chuang
Detector	Peak and Average	Test Voltage	120Vac / 60Hz

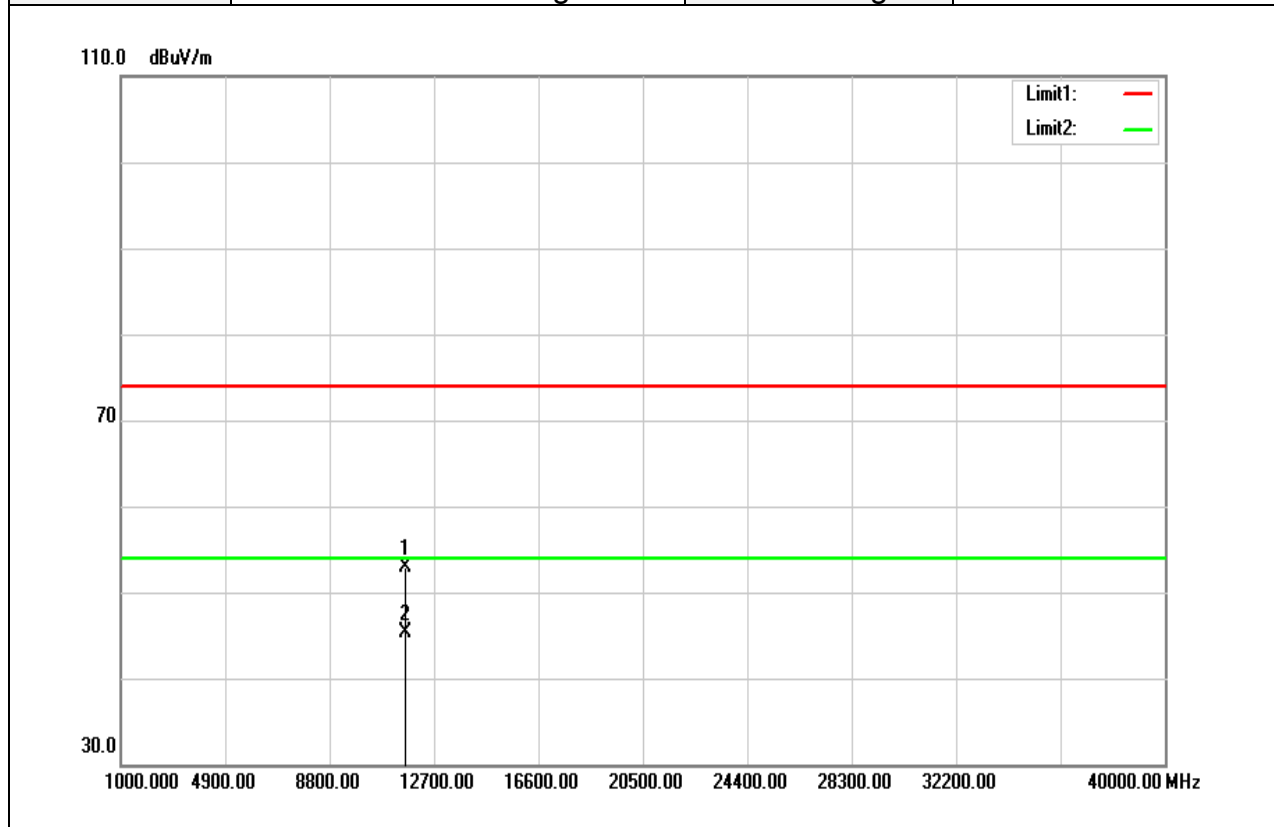

Frequency (MHz)	Reading (dBuV)	Correct Factor (dB/m)	Result (dBuV/m)	Limit (dBuV/m)	Margin (dB)	Remark
11650.000	37.02	15.93	52.95	74.00	-21.05	peak
11650.000	29.39	15.93	45.32	54.00	-8.68	AVG
N/A						

Remark:

1. Measuring frequencies from 1 GHz to the 10th harmonic of highest fundamental frequency.
2. For above 1GHz, the EUT peak value was under average limit, therefore the Average value compliance with the average limit

Test Mode	IEEE 802.11n HT40/ 5755 MHz	Temp/Hum	24(°C)/ 33%RH
Test Item	Harmonic	Test Date	November 30, 2017
Polarize	Vertical	Test Engineer	Jerry Chuang
Detector	Peak and Average	Test Voltage	120Vac / 60Hz

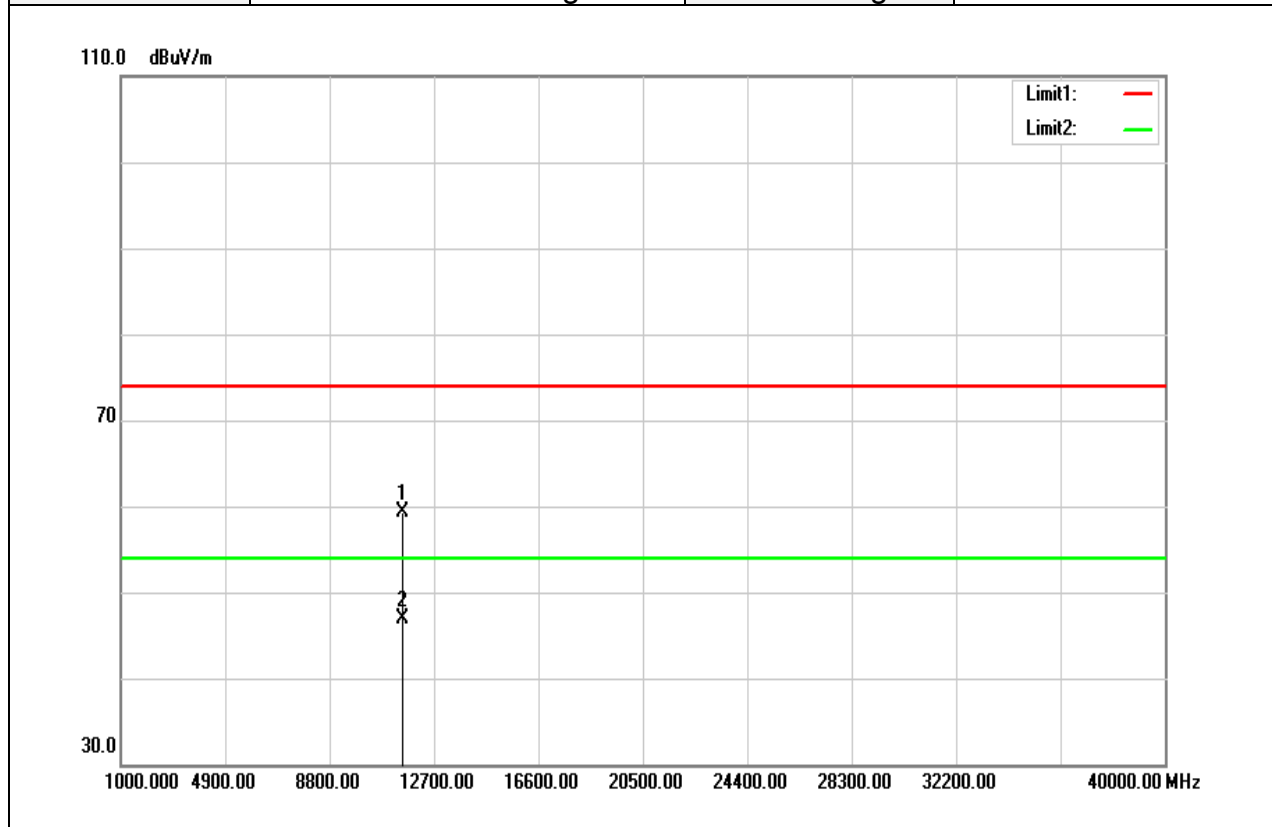

Frequency (MHz)	Reading (dBuV)	Correct Factor (dB/m)	Result (dBuV/m)	Limit (dBuV/m)	Margin (dB)	Remark
11510.000	43.30	16.08	59.38	74.00	-14.62	peak
11510.000	30.84	16.08	46.92	54.00	-7.08	AVG
N/A						

Remark:

1. Measuring frequencies from 1 GHz to the 10th harmonic of highest fundamental frequency.
2. For above 1GHz, the EUT peak value was under average limit, therefore the Average value compliance with the average limit

Test Mode	IEEE 802.11n HT40/ 5755 MHz	Temp/Hum	24(°C)/ 33%RH
Test Item	Harmonic	Test Date	November 30, 2017
Polarize	Horizontal	Test Engineer	Jerry Chuang
Detector	Peak and Average	Test Voltage	120Vac / 60Hz

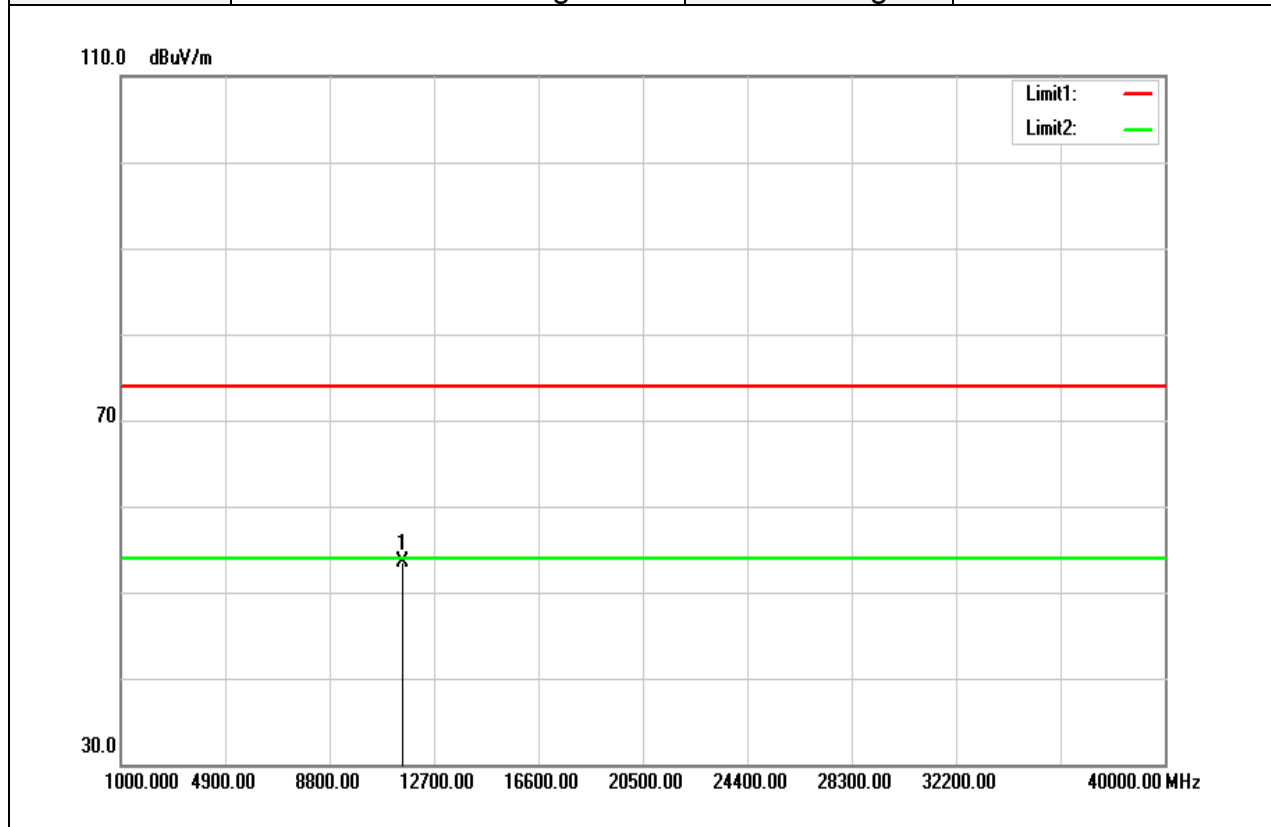

Frequency (MHz)	Reading (dBuV)	Correct Factor (dB/m)	Result (dBuV/m)	Limit (dBuV/m)	Margin (dB)	Remark
11510.000	37.43	16.08	53.51	74.00	-20.49	peak
N/A						

Remark:

1. Measuring frequencies from 1 GHz to the 10th harmonic of highest fundamental frequency.
2. For above 1GHz, the EUT peak value was under average limit, therefore the Average value compliance with the average limit

Test Mode	IEEE 802.11n HT40/ 5795 MHz	Temp/Hum	24(°C)/ 33%RH
Test Item	Harmonic	Test Date	November 30, 2017
Polarize	Vertical	Test Engineer	Jerry Chuang
Detector	Peak and Average	Test Voltage	120Vac / 60Hz

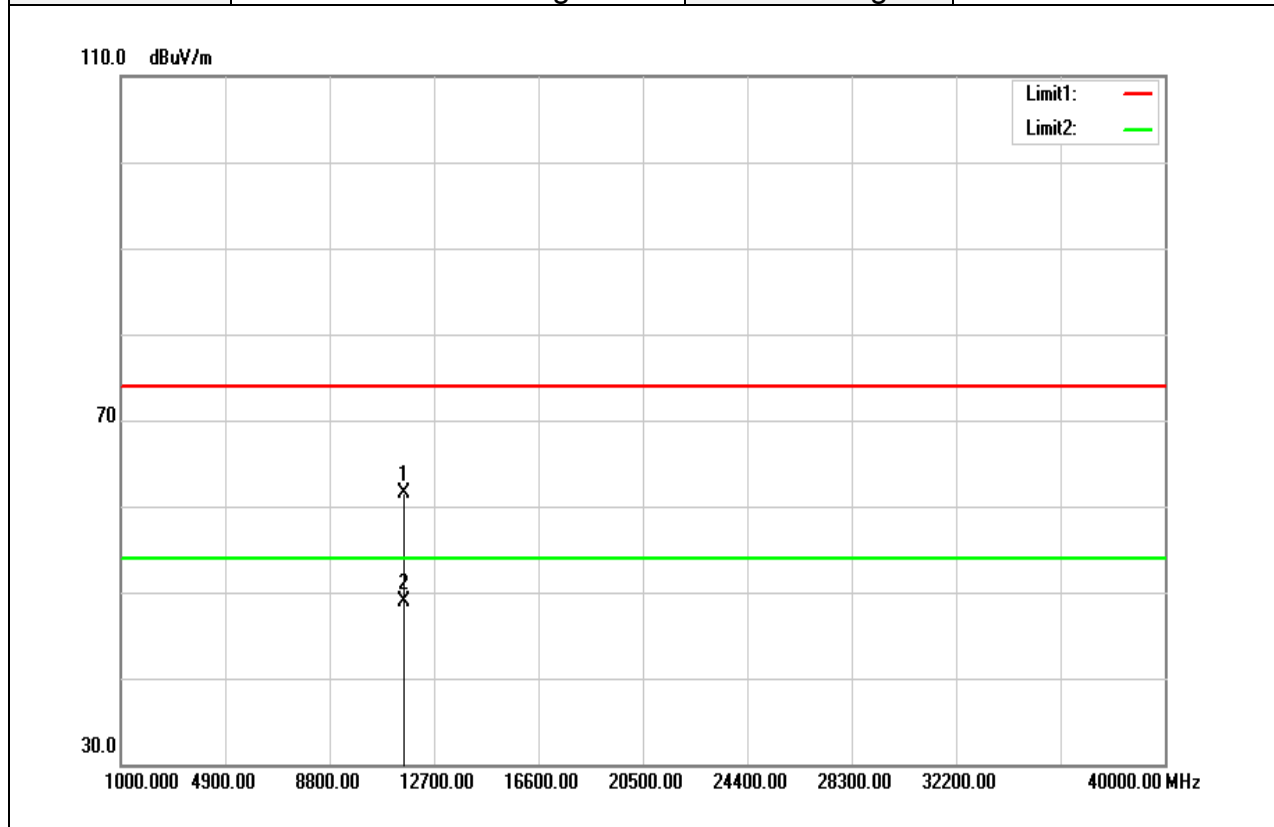

Frequency (MHz)	Reading (dBuV)	Correct Factor (dB/m)	Result (dBuV/m)	Limit (dBuV/m)	Margin (dB)	Remark
11590.000	45.60	16.00	61.60	74.00	-12.40	peak
11590.000	32.98	16.00	48.98	54.00	-5.02	AVG
N/A						

Remark:

1. Measuring frequencies from 1 GHz to the 10th harmonic of highest fundamental frequency.
2. For above 1GHz, the EUT peak value was under average limit, therefore the Average value compliance with the average limit

Test Mode	IEEE 802.11n HT40/ 5795 MHz	Temp/Hum	24(°C)/ 33%RH
Test Item	Harmonic	Test Date	November 30, 2017
Polarize	Horizontal	Test Engineer	Jerry Chuang
Detector	Peak and Average	Test Voltage	120Vac / 60Hz

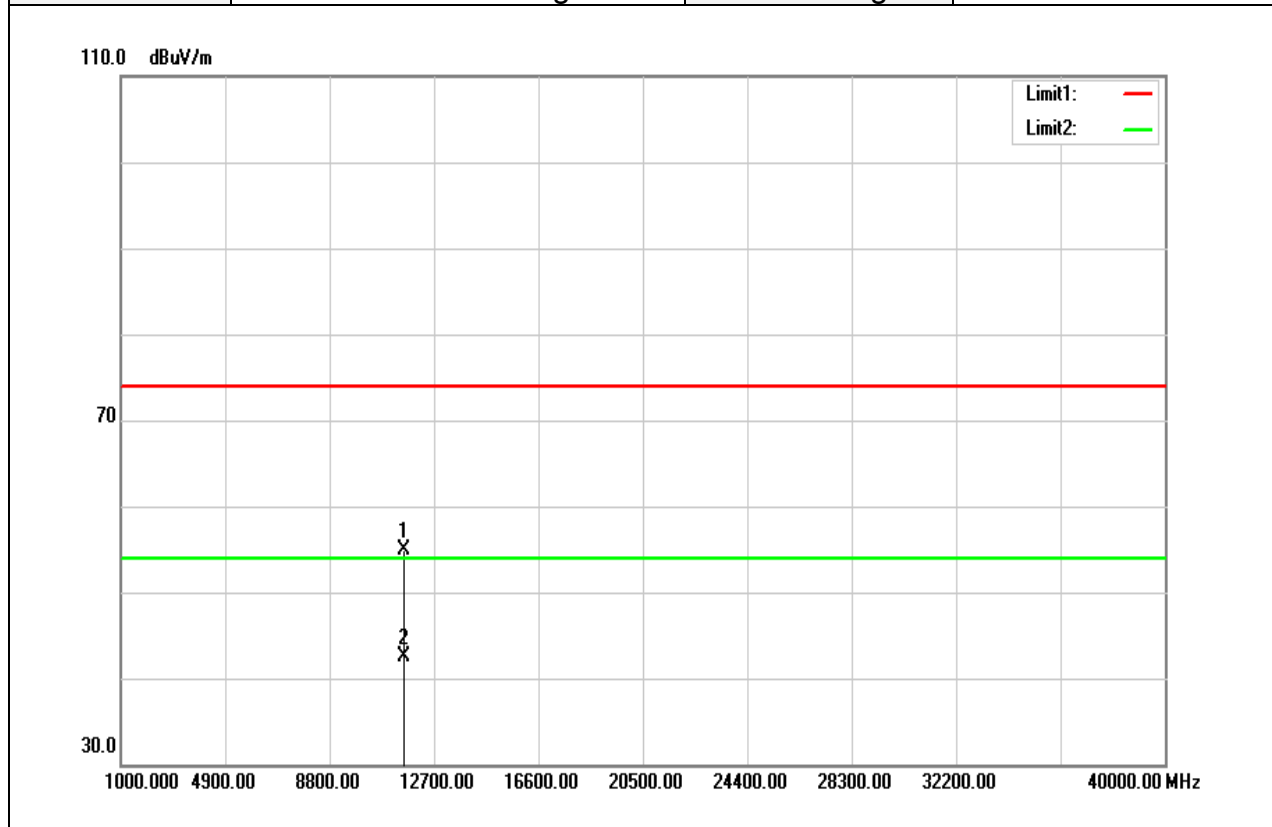

Frequency (MHz)	Reading (dBuV)	Correct Factor (dB/m)	Result (dBuV/m)	Limit (dBuV/m)	Margin (dB)	Remark
11590.000	38.98	16.00	54.98	74.00	-19.02	peak
11590.000	26.44	16.00	42.44	54.00	-11.56	AVG
N/A						

Remark:

1. Measuring frequencies from 1 GHz to the 10th harmonic of highest fundamental frequency.
2. For above 1GHz, the EUT peak value was under average limit, therefore the Average value compliance with the average limit

Test Mode	IEEE 802.11ac VHT80/ 5775 MHz	Temp/Hum	24(°C)/ 33%RH
Test Item	Harmonic	Test Date	November 30, 2017
Polarize	Vertical	Test Engineer	Jerry Chuang
Detector	Peak and Average	Test Voltage	120Vac / 60Hz

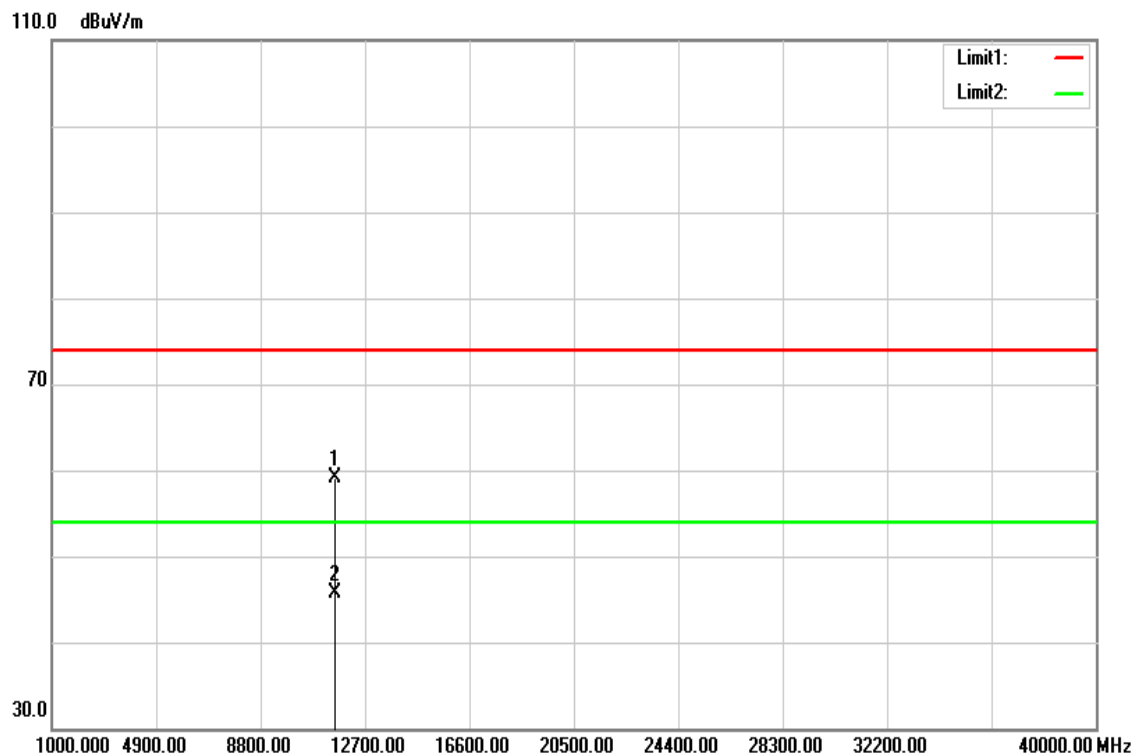

Frequency (MHz)	Reading (dBuV)	Correct Factor (dB/m)	Result (dBuV/m)	Limit (dBuV/m)	Margin (dB)	Remark
11580.000	43.05	16.00	59.05	74.00	-14.95	peak
11580.000	29.76	16.00	45.76	54.00	-8.24	AVG
N/A						

Remark:

1. Measuring frequencies from 1 GHz to the 10th harmonic of highest fundamental frequency.
2. For above 1GHz, the EUT peak value was under average limit, therefore the Average value compliance with the average limit

Test Mode	IEEE 802.11ac VHT80/ 5775 MHz	Temp/Hum	24(°C)/ 33%RH
Test Item	Harmonic	Test Date	November 30, 2017
Polarize	Horizontal	Test Engineer	Jerry Chuang
Detector	Peak and Average	Test Voltage	120Vac / 60Hz

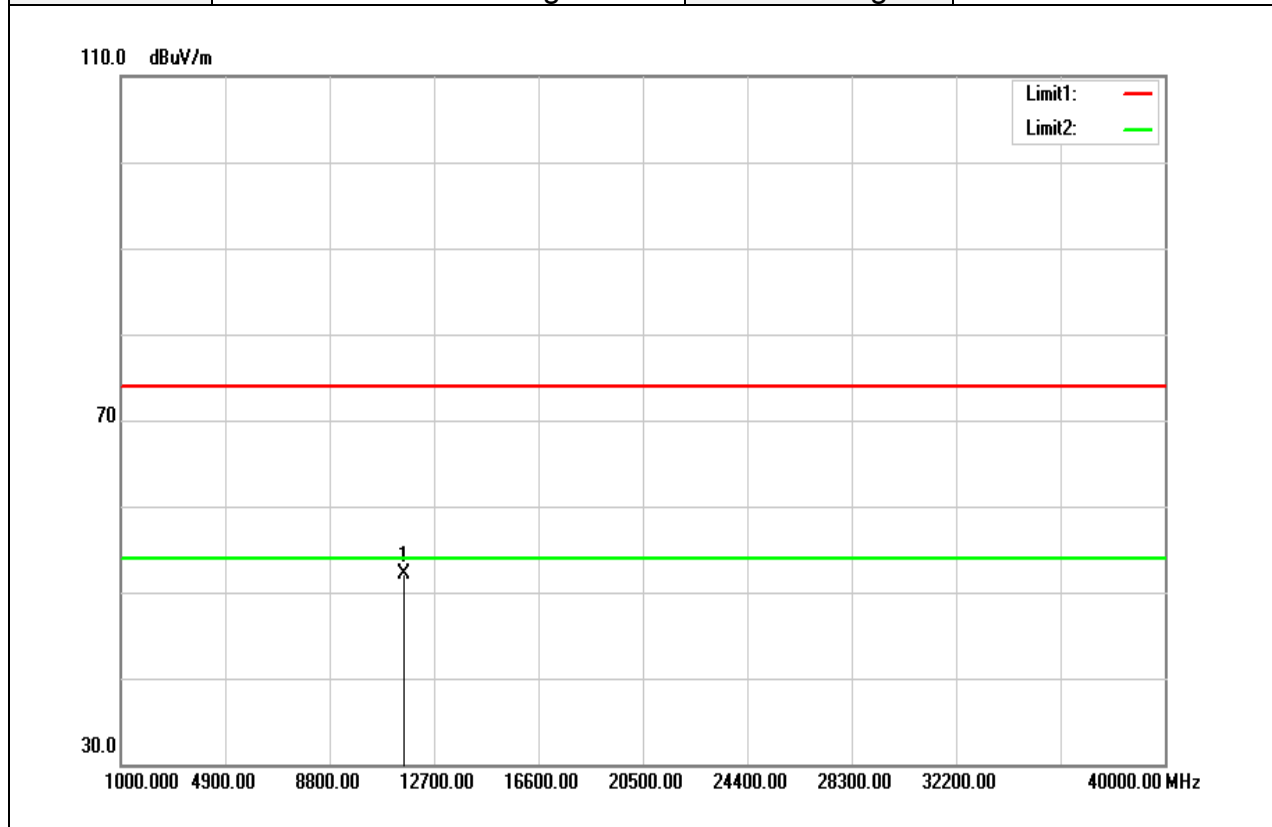

Frequency (MHz)	Reading (dBuV)	Correct Factor (dB/m)	Result (dBuV/m)	Limit (dBuV/m)	Margin (dB)	Remark
11580.000	36.16	16.00	52.16	74.00	-21.84	peak
N/A						

Remark:

1. Measuring frequencies from 1 GHz to the 10th harmonic of highest fundamental frequency.
2. For above 1GHz, the EUT peak value was under average limit, therefore the Average value compliance with the average limit

4.6 FREQUENCY STABILITY

4.6.1 Test Limit

According to §15.407(g) manufacturers of U-NII devices are responsible for ensuring frequency stability such that an emission is maintained within the band of operation under all conditions of normal operation as specified in the operational description.

4.6.2 Test Procedure

The equipment under test was connected to an external AC or DC power supply and input rated voltage. RF output was connected to a frequency counter or spectrum analyzer via feed through attenuators. The EUT was placed inside the temperature chamber. Set the spectrum analyzer RBW low enough to obtain the desired frequency resolution and measure EUT 20°C operating frequency as reference frequency. Turn EUT off and set the chamber temperature to -20°C. After the temperature stabilized for approximately 30 minutes recorded the frequency. Repeat step measure with 10°C increased per stage until the highest temperature of +50°C reached.

4.6.3 Test Setup

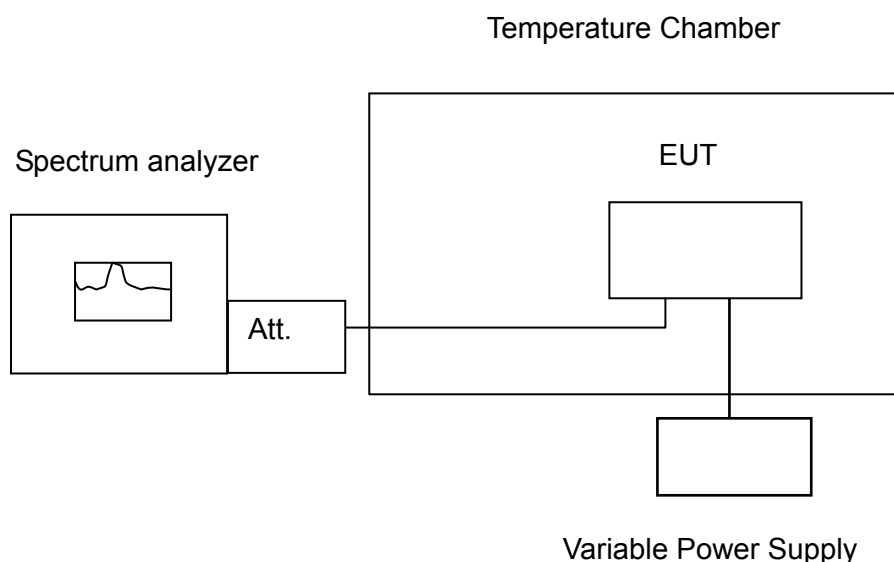

4.6.4 Test Result

Temp. (°C)	Voltage (V)	Measured Frequency	5180				Limit				Result
			Time (min)				20ppm				
Operating Frequency:		0 min	2 min	5 min	10 min	0 min	2 min	5 min	10 min		
50	5	5180.05513	5180.05651	5180.05641	5180.06321	10.6429	10.9093	10.8900	12.2027	Pass	
40	5	5180.03214	5180.03548	5180.04654	5180.04541	6.2046	6.8494	8.9846	8.7664	Pass	
30	5	5180.01356	5180.02456	5180.02851	5180.02452	2.6178	4.7413	5.5039	4.7336	Pass	
20	5	5180.00999	5180.01172	5180.01216	5180.01216	1.9286	2.2625	2.3475	2.3475	Pass	
10	5	5180.00240	5180.00269	5180.00149	5180.00159	0.4633	0.5193	0.2876	0.3069	Pass	
0	5	5179.99580	5179.99521	5179.99258	5179.99453	-0.8108	-0.9247	-1.4324	-1.0560	Pass	

Temp. (°C)	Voltage (V)	Measured Frequency	5180				Limit				Result
			Time (min)				20ppm				
Operating Frequency:		0 min	2 min	5 min	10 min	0 min	2 min	5 min	10 min		
20	4.5	5180.00911	5180.01247	5180.00999	5180.01172	1.7587	2.4073	1.9286	2.2625	Pass	
20	5	5180.00999	5180.01172	5180.01216	5180.01216	1.9286	2.2625	2.3475	2.3475	Pass	
20	5.5	5180.00864	5180.01172	5180.01264	5180.01216	1.6680	2.2625	2.4402	2.3475	Pass	

Temp. (°C)	Voltage (V)	Measured Frequency	5180				Limit				Result
			Time (min)				20ppm				
Operating Frequency:		0 min	2 min	5 min	10 min	0 min	2 min	5 min	10 min		
50	5	5260.03320	5260.04542	5260.04247	5260.04758	6.3118	8.6350	8.0741	9.0456	Pass	
40	5	5260.01695	5260.03671	5260.04654	5260.04954	3.2215	6.9791	8.8479	9.4183	Pass	
30	5	5260.02214	5260.02755	5260.03453	5260.03169	4.2091	5.2376	6.5646	6.0247	Pass	
20	5	5259.98428	5259.99646	5260.01215	5260.01389	-2.9886	-0.6730	2.3099	2.6407	Pass	
10	5	5259.98348	5259.98577	5259.98216	5259.98612	-3.1407	-2.7053	-3.3916	-2.6397	Pass	
0	5	5259.97355	5259.97615	5259.97547	5259.97785	-5.0285	-4.5342	-4.6635	-4.2110	Pass	

Temp. (°C)	Voltage (V)	Measured Frequency	5180				Limit				Result
			Time (min)				20ppm				
Operating Frequency:		0 min	2 min	5 min	10 min	0 min	2 min	5 min	10 min		
20	4.5	5259.98645	5259.99714	5260.01341	5260.01852	-2.5760	-0.5437	2.5494	3.5209	Pass	
20	5	5259.98428	5259.99646	5260.01215	5260.01389	-2.9886	-0.6730	2.3099	2.6407	Pass	
20	5.5	5259.98581	5259.99758	5260.01478	5260.01411	-2.6977	-0.4601	2.8099	2.6825	Pass	

Temp. (°C)	Voltage (V)	Measured Frequency	5180				Limit				Result
			Time (min)				20ppm				
Operating Frequency:		0 min	2 min	5 min	10 min	0 min	2 min	5 min	10 min		
50	5	5500.04450	5500.04750	5500.05421	5500.05721	8.0909	8.6364	9.8564	10.4018	Pass	
40	5	5500.04575	5500.04417	5500.04547	5500.05712	8.3182	8.0309	8.2673	10.3855	Pass	
30	5	5500.02651	5500.02457	5500.02574	5500.02515	4.8200	4.4673	4.6800	4.5722	Pass	
20	5	5499.98520	5499.98609	5499.98609	5500.01042	-2.6909	-2.5291	-2.5291	1.8945	Pass	
10	5	5499.97656	5499.97585	5499.97691	5499.97545	-4.2618	-4.3907	-4.1982	-4.4636	Pass	
0	5	5499.97571	5499.97758	5499.97875	5499.97455	-4.4164	-4.0764	-3.8636	-4.6273	Pass	
Temp. (°C)	Voltage (V)	Measured Frequency	5180				Limit				Result
			Time (min)				20ppm				
Operating Frequency:		0 min	2 min	5 min	10 min	0 min	2 min	5 min	10 min		
20	4.5	5499.98347	5499.98257	5499.98741	5500.01542	-3.0053	-3.1691	-2.2891	2.8036	Pass	
20	5	5499.98520	5499.98609	5499.98609	5500.01042	-2.6909	-2.5291	-2.5291	1.8945	Pass	
20	5.5	5499.98257	5499.98575	5499.98741	5500.01717	-3.1691	-2.5905	-2.2891	3.1218	Pass	

Temp. (°C)	Voltage (V)	Measured Frequency	5180				Limit				Result
			Time (min)				20ppm				
Operating Frequency:		0 min	2 min	5 min	10 min	0 min	2 min	5 min	10 min		
50	5	5745.05174	5745.05741	5745.05417	5745.05744	9.0061	9.9930	9.4291	9.9983	Pass	
40	5	5745.04330	5745.04874	5745.05571	5745.05587	7.5363	8.4839	9.6971	9.7250	Pass	
30	5	5745.03417	5745.03142	5745.03527	5745.03147	5.9478	5.4686	6.1393	5.4778	Pass	
20	5	5745.01172	5745.01710	5745.02724	5745.02471	2.0400	2.9765	4.7415	4.3011	Pass	
10	5	5744.98452	5744.98741	5744.98775	5744.98104	-2.6945	-2.1915	-2.1323	-3.3003	Pass	
0	5	5744.97270	5744.97814	5744.97741	5744.97852	-4.7520	-3.8050	-3.9321	-3.7389	Pass	
Temp. (°C)	Voltage (V)	Measured Frequency	5180				Limit				Result
			Time (min)				20ppm				
Operating Frequency:		0 min	2 min	5 min	10 min	0 min	2 min	5 min	10 min		
20	4.5	5745.01471	5745.01781	5745.02413	5745.02527	2.5605	3.1008	4.2002	4.3986	Pass	
20	5	5745.01172	5745.01710	5745.02724	5745.02471	2.0400	2.9765	4.7415	4.3011	Pass	
20	5.5	5745.01652	5745.01172	5745.02257	5745.02147	2.8755	2.0400	3.9286	3.7372	Pass	

4.7 DYNAMIC FREQUENCY SELECTION

4.7.1 Test Limit

FCC according to §15.407 (h), KDB 905462 D02 "compliance measurement procedures for unlicensed-national information infrastructure devices operating in the 5250-5350 MHz and 5470-5725 MHz bands incorporating dynamic frequency selection". and KDB 905462 D03 " U-NII client devices without radar detection capability.

IC according RSS-247 section 6.3, and it harmonized with FCC Part 15 DFS rules.

The EIRP refer section 4.3 output power measurement in this report.

Table 1: Applicability of DFS requirements prior to use of a channel

Requirement	Operational Mode		
	Master	Client (without radar detection)	Client(with radar detection)
Non-Occupancy Period	Yes	Not required	Yes
DFS Detection Threshold	Yes	Not required	Yes
Channel Availability Check Time	Yes	Not required	Not required
U-NII Detection Bandwidth	Yes	Not required	Yes

Table 2: Applicability of DFS requirements during normal operation

Requirement	Operational Mode	
	Master Device or Client with Radar Detection	Client Without Radar Detection
DFS Detection Threshold	Yes	Not required
Channel Closing Transmission Time	Yes	Yes
Channel Move Time	Yes	Yes
U-NII Detection Bandwidth	Yes	Not required

Additional requirements for devices with multiple bandwidth mods	Master Device or Client with Radar Detection	Client Without Radar Detection
U-NII Detection Bandwidth and Statistical Performance Check	All BW modes must be tested	Not required
Channel Move Time and Channel Closing Transmission Time	Test using widest BW mode available	Test using the widest BW mode available for the link
All other tests	Any single BW mode	Not required

Note: Frequencies selected for statistical performance check (Section 7.8.4) should include several frequencies within the radar detection bandwidth and frequencies near the edge of the radar detection bandwidth. For 802.11 devices it is suggested to select frequencies in each of the bonded 20 MHz channels and the channel center frequency.

Table 3: Interference Threshold values, Master or Client incorporating In-Service

Maximum Transmit Power	Value (See Notes 1, 2, and 3)
EIRP ≥ 200 milliwatt	-64 dBm
EIRP < 200 milliwatt and power spectral density < 10 dBm/MHz	-62 dBm
EIRP < 200 milliwatt that do not meet the power spectral density requirement	-64 dBm

Note 1: This is the level at the input of the receiver assuming a 0 dBi receive antenna.
Note 2: Throughout these test procedures an additional 1 dB has been added to the amplitude of the test transmission waveforms to account for variations in measurement equipment. This will ensure that the test signal is at or above the detection threshold level to trigger a DFS response.
Note 3: EIRP is based on the highest antenna gain. For MIMO devices refer to KDB Publication 662911 D01.

Table 4: DFS Response requirement values

Parameter	Value
Non-occupancy period	Minimum 30 minutes
Channel Availability Check Time	60 seconds
Channel Move Time	10 seconds See Note 1.
Channel Closing Transmission Time	200 milliseconds + an aggregate of 60 milliseconds over remaining 10 second period. See Notes 1 and 2.
U-NII Detection Bandwidth	Minimum 100% of the U-NII 99% transmission power bandwidth. See Note 3.

Note 1: Channel Move Time and the Channel Closing Transmission Time should be performed with Radar Type 0. The measurement timing begins at the end of the Radar Type 0 burst.
Note 2: The Channel Closing Transmission Time is comprised of 200 milliseconds starting at the beginning of the Channel Move Time plus any additional intermittent control signals required to facilitate a Channel move (an aggregate of 60 milliseconds) during the remainder of the 10 second period. The aggregate duration of control signals will not count quiet periods in between transmissions.
Note 3: During the U-NII Detection Bandwidth detection test, radar type 0 should be used. For each frequency step the minimum percentage of detection is 90 percent. Measurements are performed with no data traffic.

Table 5 – Short Pulse Radar Test Waveforms

Radar Type	Pulse Width (µsec)	PRI (µsec)	Number of Pulses	Minimum Percentage of Successful Detection	Minimum Number of Trials
0	1	1428	18	See Note 1	
1	1	Test A: 15 unique PRI values randomly selected from the list of 23 PRI values in Table 5a	$\text{Roundup} \left\{ \begin{array}{l} \left(\frac{1}{360} \right) \cdot \\ \left(\frac{19 \cdot 10^6}{\text{PRI}_{\mu\text{sec}}} \right) \end{array} \right\}$	60%	30
		Test B: 15 unique PRI values randomly selected within the range of 518-3066 µsec, with a minimum increment of 1 µsec, excluding PRI values selected in Test A			
2	1-5	150-230	23-29	60%	30
3	6-10	200-500	16-18	60%	30
4	11-20	200-500	12-16	60%	30
Aggregate (Radar Types 1-4)				80%	120
Note 1: Short Pulse Radar Type 0 should be used for the detection bandwidth test, channel move time, and channel closing time tests.					

Table 6 – Long Pulse Radar Test Signal

Radar Type	Pulse Width (µsec)	Chirp Width (MHz)	PRI (µsec)	Number of Pulses per Burst	Number of Bursts	Minimum Percentage of Successful Detection	Minimum Number of Trials
5	50-100	5-20	1000-2000	1-3	8-20	80%	30

Table 7 – Frequency Hopping Radar Test Signal

Radar Type	Pulse Width (µsec)	PRI (µsec)	Pulses per Hop	Hopping Rate (kHz)	Hopping Sequence Length (msec)	Minimum Percentage of Successful Detection	Minimum Number of Trials
6	1	333	9	0.333	300	70%	30

4.7.2 Test Procedure

Overview Of EUT With Respect To §15.407 (H) Requirements

The firmware installed in the EUT during testing was:

Firmware Rev: ??

The EUT operates over the 5250-5350 MHz range as a Client Device that does not have radar detection capability.

The EUT uses one transmitter connected to two 50-ohm coaxial antenna ports via a diversity switch. Only one antenna port is connected to the test system since the EUT has one antenna only.

The Slave device associated with the EUT during these tests does not have radar detection capability.

WLAN traffic is generated by streaming the video file TestFile.mp2 “6 ½ Magic Hours” from the Master to the Slave in full motion video mode using the media player with the V2.61 Codec package.

The EUT utilizes the 802.11a architecture, with a nominal channel bandwidth of 20 MHz.

The rated output power of the Master unit is < 23dBm (EIRP). Therefore the required interference threshold level is -62 dBm. After correction for antenna gain and procedural adjustments, the required conducted threshold at the antenna port is $-62 + 5 = -57$ dBm.

The calibrated conducted DFS Detection Threshold level is set to -57 dBm. The tested level is lower than the required level hence it provides margin to the limit.

Manufacturer’s Statement Regarding Uniform Channel Spreading

The end product implements an automatic channel selection feature at startup such that operation commences on channels distributed across the entire set of allowed 5GHz channels. This feature will ensure uniform spreading is achieved while avoiding non-allowed channels due to prior radar events.

TEST AND MEASUREMENT SYSTEM

System Overview

The measurement system is based on a conducted test method.

The short pulse and long pulse signal generating system utilizes the NTIA software. The Vector Signal Generator has been validated by the NTIA. The hopping signal generating system utilizes the CCS simulated hopping method and system, which has been validated by the DoD, FCC and NTIA. The software selects waveform parameters from within the bounds of the signal type on a random basis using uniform distribution.

The short pulse types 2, 3 and 4, and the long pulse type 5 parameters are randomized at run-time.

The hopping type 6 pulse parameters are fixed while the hopping sequence is based on the August 2005 NTIA Hopping Frequency List. The initial starting point randomized at run-time and each subsequent starting point is incremented by 475. Each frequency in the 100-length segment is compared to the boundaries of the EUT Detection Bandwidth and the software creates a hopping burst pattern in accordance with Section 7.4.1.3 Method #2 Simulated Frequency Hopping Radar Waveform Generating Subsystem of FCC 06-96 APPENDIX. The frequency of the signal generator is incremented in 1 MHz steps from FL to FH for each successive trial. This incremental sequence is repeated as required to generate a minimum of 30 total trials and to maintain a uniform frequency distribution over the entire Detection Bandwidth.

The signal monitoring equipment consists of a spectrum analyzer set to display 8001 bins on the horizontal axis. The time-domain resolution is 2 msec / bin with a 16 second sweep time, meeting the 10 second short pulse reporting criteria. The aggregate ON time is calculated by multiplying the number of bins above a threshold during a particular observation period by the dwell time per bin, with the analyzer set to peak detection and max hold. The time-domain resolution is 3 msec / bin with a 24 second sweep time, meeting the 22 second long pulse reporting criteria and allowing a minimum of 10 seconds after the end of the long pulse waveform.

Should multiple RF ports be utilized for the Master and/or Slave devices (for example, for diversity or MIMO implementations), 50 ohm termination would be removed from the splitter so that connection can be established between splitter and the Master and/or Slave devices.

Conducted Method System Block Diagram

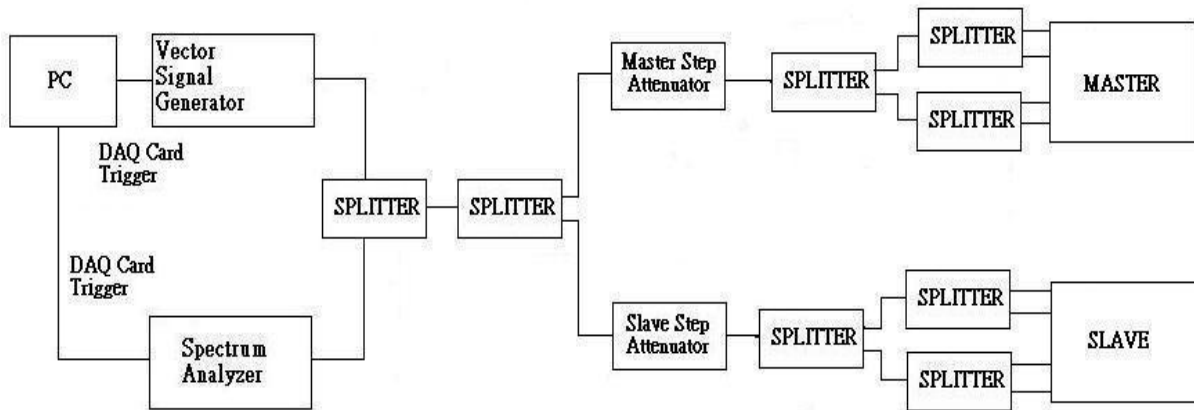

System Calibration

Connect the spectrum analyzer to the test system in place of the master device. Set the signal generator to CW mode. Adjust the amplitude of the signal generator to yield a measured level of -62 dBm on the spectrum analyzer.

Without changing any of the instrument settings, reconnect the spectrum analyzer to the Common port of the Spectrum Analyzer Combiner/Divider and connect a 50 ohm load to the Master Device port of the test system.

Measure the amplitude and calculate the difference from -62 dBm. Adjust the Reference Level Offset of the spectrum analyzer to this difference. Confirm that the signal is displayed at -62 dBm. Readjust the RBW and VBW to 3 MHz, set the span to 10 MHz, and confirm that the signal is still displayed at -62 dBm.

The spectrum analyzer displays the level of the signal generator as received at the antenna ports of the Master Device. The interference detection threshold may be varied from the calibrated value of -62 dBm and the spectrum analyzer will still indicate the level as received by the Master Device.

Set the signal generator to produce a radar waveform, trigger a burst manually and measure the level on the spectrum analyzer. Readjust the amplitude of the signal generator as required so that the peak level of the waveform is at a displayed level equal to the required or desired interference detection threshold. Separate signal generator amplitude settings are determined as required for each radar type.

Adjustment Of Displayed Traffic Level

Establish a link between the Master and Slave, adjusting the Link Step Attenuator as needed to provide a suitable received level at the Master and Slave devices. Stream the video test file to generate WLAN traffic. Confirm that the WLAN traffic level, as displayed on the spectrum analyzer, is at lower amplitude than the radar detection threshold. Confirm that the displayed traffic is from the Master Device. For Master Device testing confirm that the displayed traffic does not include Slave Device traffic. For Slave Device testing confirm that the displayed traffic does not include Master Device traffic.

If a different setting of the Master Step Attenuator is required to meet the above conditions, perform a new System Calibration for the new Master Step Attenuator setting.

4.7.3 Test Setup

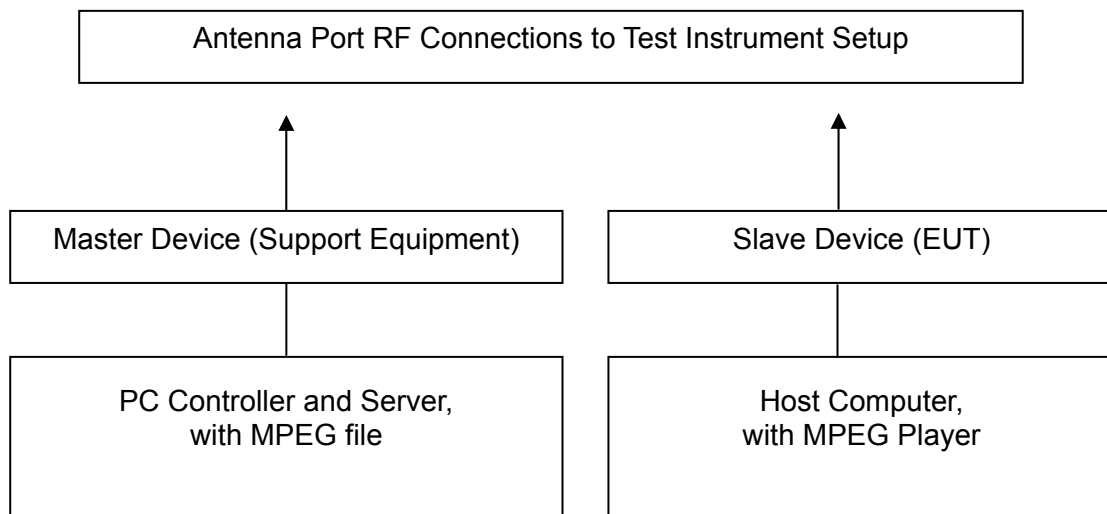

4.7.4 Test Result

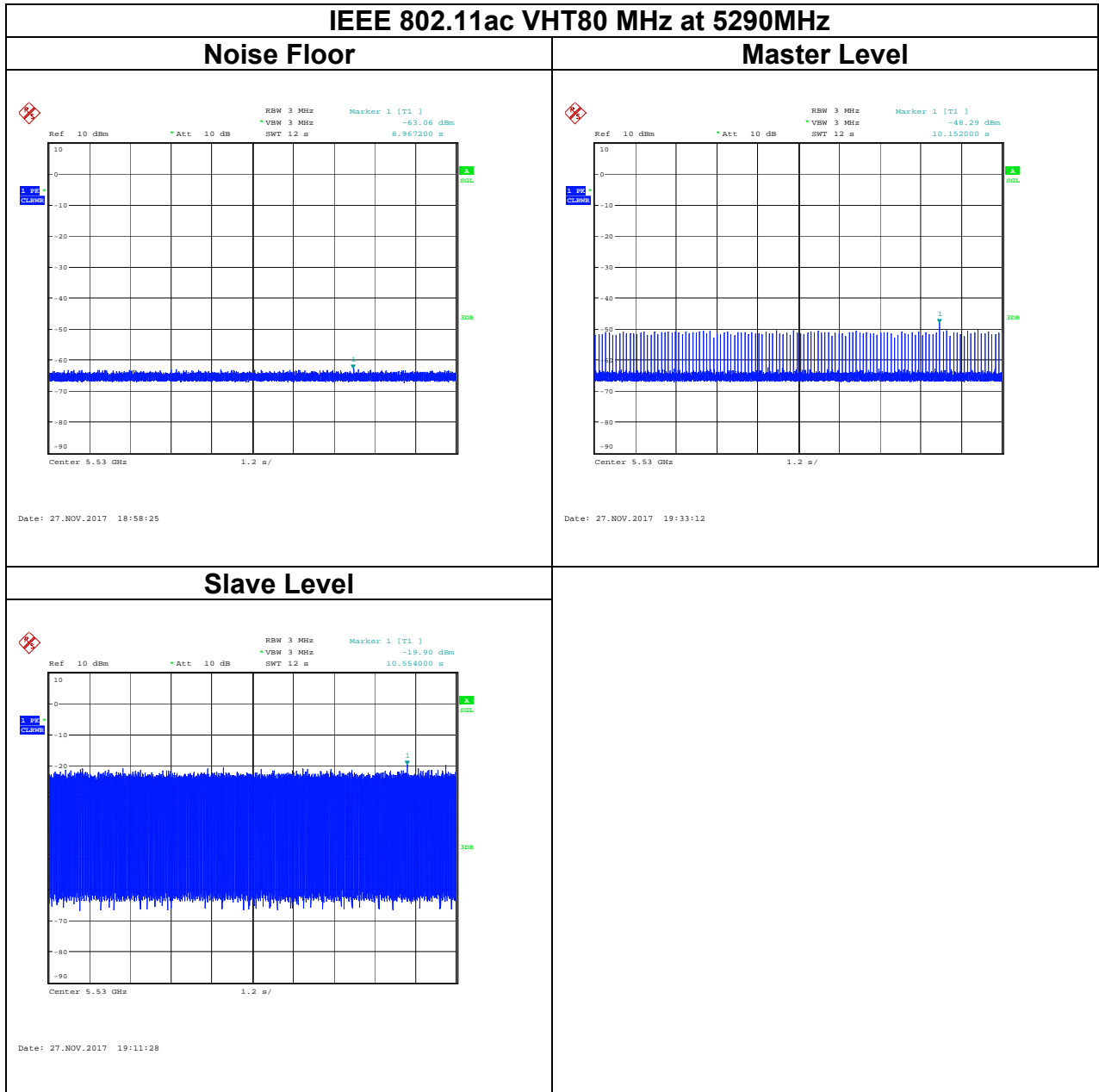

Radar Waveforms

Sample of short Pluse Radar Type 0

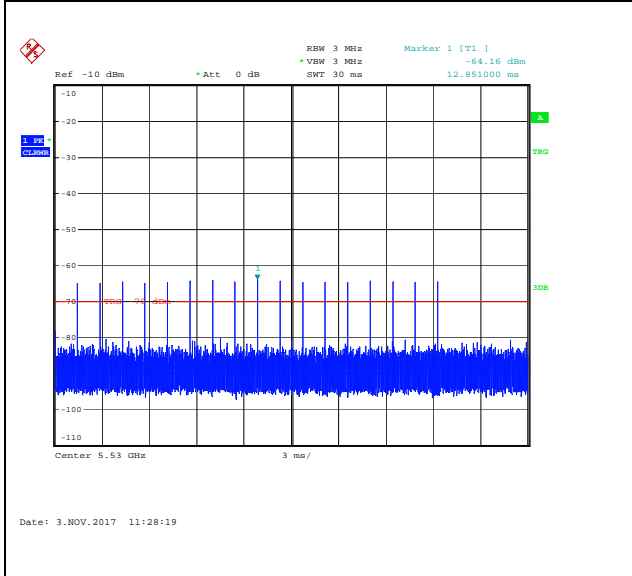

TEST CHANNEL AND METHOD

All tests were performed at a channel center frequency of 5530 MHz utilizing a conducted test method.

CHANNEL MOVE TIME AND CHANNEL CLOSING TRANSMISSION TIME

GENERAL REPORTING NOTES

The reference marker is set at the end of last radar pulse.

The delta marker is set at the end of the last WLAN transmission following the radar pulse. This delta is the channel move time.

The aggregate channel closing transmission time is calculated as follows:

Aggregate Transmission Time =

(Number of analyzer bins showing transmission) * (dwell time per bin)

The observation period over which the aggregate time is calculated

Begins at (Reference Marker + 200 msec) and

Ends no earlier than (Reference Marker + 10 sec).

IEEE 802.11ac VHT 80 MHz at 5530

Type 1_Channel Move Time

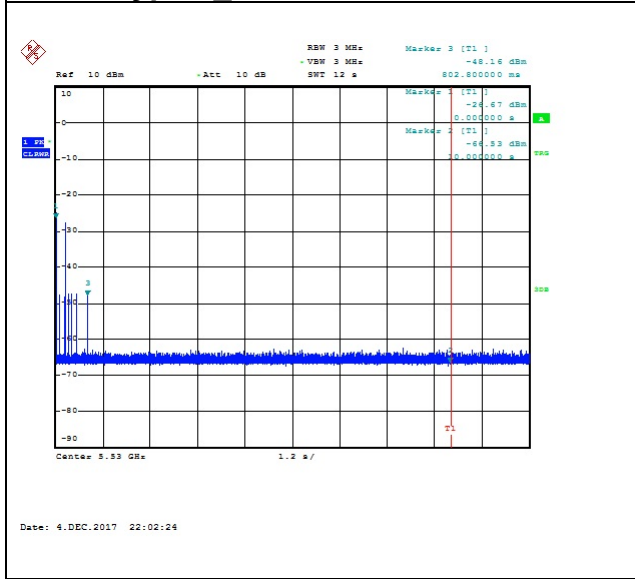

Channel Move Time (s)	Limit (s)
0.8028	10

IEEE 802.11ac VHT 80 MHz at 5290

Type 1_Channel closing transmission time

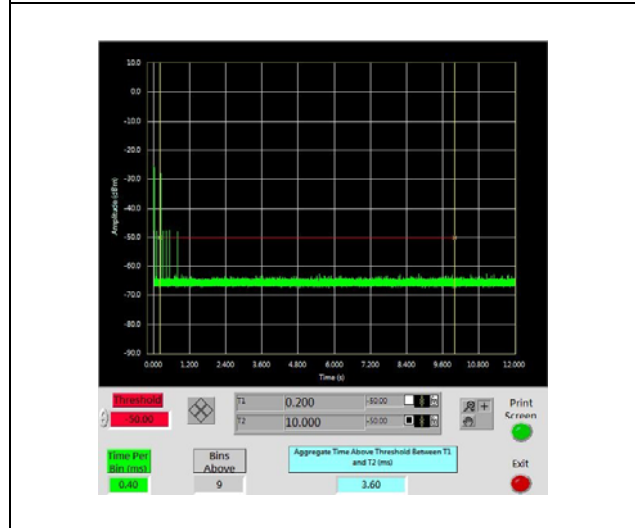

Type 1_Channel closing transmission time-caculate

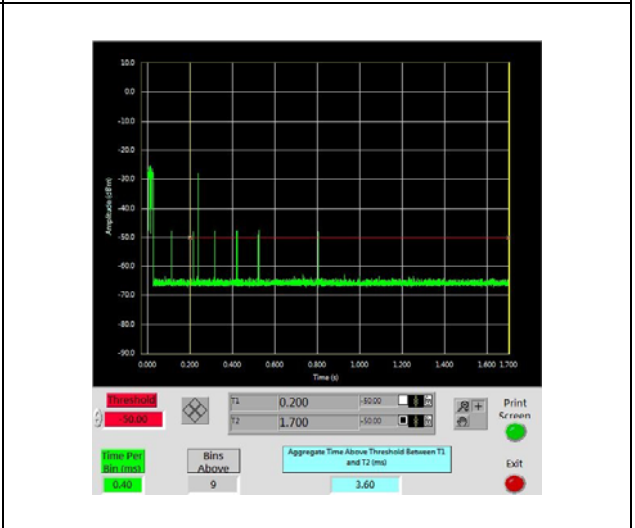

Aggregate Transmission Time (ms)	Limit (ms)	Margin (ms)
3.6	60	-56.4

4.8 SUMMERY OF THE SPOT CHECK FOR UNLICENSED BANDS

Report	Test Item	Channel	Measured Frequency	PPQ-WCBN3509ANB		PPQ-WCBN3509A		Gap (dB)	
				Peak	Average	Peak	Average	Peak	Average
UNII (20MHz)	Band edge	36	5149.200	70.70	51.59	67.29	45.19	3.41	6.4
	RSE	36	10360.000	56.41	46.78	54.95	45.78	1.46	1
UNII (40MHz)	Band edge	102	5468.400	70.42	51.58	70.02	50.19	0.4	1.39
	RSE	102	11020.000	60.16	50.11	54.77	44.38	5.39	5.73
UNII (80MHz)	Band edge	106	5465.560	64.73	52.32	62.34	51.68	2.39	0.64
	RSE	106	11060.000	52.47	-	51.15	-	1.32	-