

# FC

## Test Report

|              |                |
|--------------|----------------|
| Product Name | Play-Fi Player |
| Model No.    | Play-Fi Player |
| FCC ID.      | PPQ-PLAYFIP1   |

|           |   |
|-----------|---|
| Applicant | Lite-On Technology Corp.  |
| Address   | 4F, 90, Chien 1 Road, Chung-Ho, Taipei Hsien 235,<br>Taiwan, R.O.C. |

|                 |                    |
|-----------------|--------------------|
| Date of Receipt | Mar. 19, 2012      |
| Issued Date     | Apr. 27, 2012      |
| Report No.      | 123300R-RFUSP29V01 |
| Report Version  | V1.0               |



The Test Results relate only to the samples tested.

The test report shall not be reproduced except in full without the written approval of QuieTek Corporation.

This report must not be used to claim product endorsement by NVLAP any agency of the U.S. Government

# Test Report Certification

Issued Date: Apr. 27, 2012

Report No.: 123300R-RFUSP29V01



|                     |  |
|---------------------|--|
| Product Name        | Play-Fi Player   |
| Applicant           | Lite-On Technology Corp.   |
| Address             | 4F, 90, Chien 1 Road, Chung-Ho, Taipei Hsien 235, Taiwan, R.O.C. |
| Manufacturer        | DONG GUAN G-COM COMPUTER CO., LTD.                               |
| Model No.           | Play-Fi Player   |
| FCC ID.             | PPQ-PLAYFIP1   |
| EUT Rated Voltage   | AC 100-240V, 50-60Hz   |
| EUT Test Voltage    | AC 120V/ 60Hz  |
| Trade Name          | Phorus   |
| Applicable Standard | FCC CFR Title 47 Part 15 Subpart C: 2010<br>ANSI C63.4: 2003     |
| Test Result         | Complied   |

The Test Results relate only to the samples tested.

The test report shall not be reproduced except in full without the written approval of Quietek Corporation.

This report must not be used to claim product endorsement by NVLAP any agency of the U.S. Government

Documented By : Rita Huang  
( Senior Adm. Specialist / Rita Huang )

Tested By : Nowal Kuo  
( Engineer / Nowal Kuo )

Approved By : Vincent Lin  
( Manager / Vincent Lin )

## TABLE OF CONTENTS

| Description  | Page      |
|--|-----------|
| <b>1. GENERAL INFORMATION .....</b>                | <b>5</b>  |
| 1.1. EUT Description.....                          | 5         |
| 1.2. Operational Description.....                  | 7         |
| 1.3. Tested System Details.....                    | 8         |
| 1.4. Configuration of Tested System .....          | 9         |
| 1.5. EUT Exercise Software .....                   | 9         |
| 1.6. Test Facility .....                           | 10        |
| <b>2. CONDUCTED EMISSION .....</b>                 | <b>11</b> |
| 2.1. Test Equipment.....                           | 11        |
| 2.2. Test Setup .....                              | 11        |
| 2.3. Limits.....                                   | 12        |
| 2.4. Test Procedure .....                          | 12        |
| 2.5. Uncertainty .....                             | 12        |
| 2.6. Test Result of Conducted Emission.....        | 13        |
| <b>3. PEAK POWER OUTPUT .....</b>                  | <b>15</b> |
| 3.1. Test Equipment.....                           | 15        |
| 3.2. Test Setup .....                              | 15        |
| 3.3. Limit .....                                   | 15        |
| 3.4. Test Procedure .....                          | 15        |
| 3.5. Uncertainty .....                             | 15        |
| 3.6. Test Result of Peak Power Output.....         | 16        |
| <b>4. RADIATED EMISSION .....</b>                  | <b>18</b> |
| 4.1. Test Equipment.....                           | 18        |
| 4.2. Test Setup .....                              | 18        |
| 4.3. Limits.....                                   | 19        |
| 4.4. Test Procedure .....                          | 20        |
| 4.5. Uncertainty .....                             | 20        |
| 4.6. Test Result of Radiated Emission.....         | 21        |
| <b>5. RF ANTENNA CONDUCTED TEST .....</b>          | <b>28</b> |
| 5.1. Test Equipment.....                           | 28        |
| 5.2. Test Setup .....                              | 29        |
| 5.3. Limits.....                                   | 29        |
| 5.4. Test Procedure .....                          | 29        |
| 5.5. Uncertainty .....                             | 29        |
| 5.6. Test Result of RF Antenna Conducted Test..... | 30        |
| <b>6. BAND EDGE .....</b>                          | <b>42</b> |
| 6.1. Test Equipment.....                           | 42        |
| 6.2. Test Setup .....                              | 43        |
| 6.3. Limit .....                                   | 44        |
| 6.4. Test Procedure .....                          | 44        |
| 6.5. Uncertainty .....                             | 44        |

|            |   |           |
|------------|---|-----------|
| 6.6.       | Test Result of Band Edge .....                              | 45        |
| <b>7.</b>  | <b>CHANNEL NUMBER.....</b>                                  | <b>53</b> |
| 7.1.       | Test Equipment .....  | 53        |
| 7.2.       | Test Setup .....  | 53        |
| 7.3.       | Limit .....   | 53        |
| 7.4.       | Test Procedure .....  | 53        |
| 7.5.       | Uncertainty .....   | 53        |
| 7.6.       | Test Result of Channel Number.....                          | 54        |
| <b>8.</b>  | <b>CHANNEL SEPARATION.....</b>                              | <b>56</b> |
| 8.1.       | Test Equipment .....  | 56        |
| 8.2.       | Test Setup .....  | 56        |
| 8.3.       | Limit .....   | 56        |
| 8.4.       | Test Procedure .....  | 56        |
| 8.5.       | Uncertainty .....   | 56        |
| 8.6.       | Test Result of Channel Separation.....                      | 57        |
| <b>9.</b>  | <b>DWELL TIME.....</b>                                      | <b>61</b> |
| 9.1.       | Test Equipment .....  | 61        |
| 9.2.       | Test Setup .....  | 61        |
| 9.3.       | Limit .....   | 61        |
| 9.4.       | Test Procedure .....  | 61        |
| 9.5.       | Uncertainty .....   | 61        |
| 9.6.       | Test Result of Dwell Time .....                             | 62        |
| <b>10.</b> | <b>OCCUPIED BANDWIDTH .....</b>                             | <b>66</b> |
| 10.1.      | Test Equipment .....  | 66        |
| 10.2.      | Test Setup .....  | 66        |
| 10.3.      | Limits.....   | 66        |
| 10.4.      | Test Procedure .....  | 66        |
| 10.5.      | Uncertainty .....   | 66        |
| 10.6.      | Test Result of Occupied Bandwidth .....                     | 67        |
| <b>11.</b> | <b>EMI REDUCTION METHOD DURING COMPLIANCE TESTING .....</b> | <b>73</b> |

Attachment 1: EUT Test Photographs

Attachment 2: EUT Detailed Photographs

## 1. GENERAL INFORMATION

### 1.1. EUT Description

|                    |   |
|--------------------|---|
| Product Name       | Play-Fi Player  |
| Trade Name         | Phorus  |
| Model No.          | Play-Fi Player  |
| FCC ID.            | PPQ-PLAYFIP1  |
| Frequency Range    | 2402 – 2480MHz  |
| Channel Number     | 79  |
| Type of Modulation | FHSS: GFSK(1Mbps) / $\pi$ /4DQPSK(2Mbps) / 8DPSK(3Mbps)   |
| Antenna Type       | Printed on PCB  |
| Channel Control    | Auto  |
| Antenna Gain       | Refer to the table “Antenna List”   |
| USB Cable          | Non-Shielded, 0.4m  |
| USB Cable          | Non-Shielded, 0.4m  |
| Power Adapter      | MFR: Asian Power Devices INC., M/N: WA-24E12FU<br>Input: AC 100-240V, 50-60Hz, 0.65A<br>Output: DC 12V, 2A<br>Cable Out: Non-Shielded, 1.5m |

#### Antenna List

| No. | Manufacturer    | Part No. | Antenna Type   | Peak Gain           |
|-----|-----------------|----------|----------------|---------------------|
| 1   | DONG GUAN G-COM | N/A      | Printed on PCB | 2.52dBi for 2.4 GHz |

Note: The antenna of EUT is conform to FCC 15.203.

## Frequency of Each Channel:

| Channel     | Frequency | Channel     | Frequency | Channel     | Frequency | Channel     | Frequency |
|-------------|-----------|-------------|-----------|-------------|-----------|-------------|-----------|
| Channel 00: | 2402 MHz  | Channel 20: | 2422 MHz  | Channel 40: | 2442 MHz  | Channel 60: | 2462 MHz  |
| Channel 01: | 2403 MHz  | Channel 21: | 2423 MHz  | Channel 41: | 2443 MHz  | Channel 61: | 2463 MHz  |
| Channel 02: | 2404 MHz  | Channel 22: | 2424 MHz  | Channel 42: | 2444 MHz  | Channel 62: | 2464 MHz  |
| Channel 03: | 2405 MHz  | Channel 23: | 2425 MHz  | Channel 43: | 2445 MHz  | Channel 63: | 2465 MHz  |
| Channel 04: | 2406 MHz  | Channel 24: | 2426 MHz  | Channel 44: | 2446 MHz  | Channel 64: | 2466 MHz  |
| Channel 05: | 2407 MHz  | Channel 25: | 2427 MHz  | Channel 45: | 2447 MHz  | Channel 65: | 2467 MHz  |
| Channel 06: | 2408 MHz  | Channel 26: | 2428 MHz  | Channel 46: | 2448 MHz  | Channel 66: | 2468 MHz  |
| Channel 07: | 2409 MHz  | Channel 27: | 2429 MHz  | Channel 47: | 2449 MHz  | Channel 67: | 2469 MHz  |
| Channel 08: | 2410 MHz  | Channel 28: | 2430 MHz  | Channel 48: | 2450 MHz  | Channel 68: | 2470 MHz  |
| Channel 09: | 2411 MHz  | Channel 29: | 2431 MHz  | Channel 49: | 2451 MHz  | Channel 69: | 2471 MHz  |
| Channel 10: | 2412 MHz  | Channel 30: | 2432 MHz  | Channel 50: | 2452 MHz  | Channel 70: | 2472 MHz  |
| Channel 11: | 2413 MHz  | Channel 31: | 2433 MHz  | Channel 51: | 2453 MHz  | Channel 71: | 2473 MHz  |
| Channel 12: | 2414 MHz  | Channel 32: | 2434 MHz  | Channel 52: | 2454 MHz  | Channel 72: | 2474 MHz  |
| Channel 13: | 2415 MHz  | Channel 33: | 2435 MHz  | Channel 53: | 2455 MHz  | Channel 73: | 2475 MHz  |
| Channel 14: | 2416 MHz  | Channel 34: | 2436 MHz  | Channel 54: | 2456 MHz  | Channel 74: | 2476 MHz  |
| Channel 15: | 2417 MHz  | Channel 35: | 2437 MHz  | Channel 55: | 2457 MHz  | Channel 75: | 2477 MHz  |
| Channel 16: | 2418 MHz  | Channel 36: | 2438 MHz  | Channel 56: | 2458 MHz  | Channel 76: | 2478 MHz  |
| Channel 17: | 2419 MHz  | Channel 37: | 2439 MHz  | Channel 57: | 2459 MHz  | Channel 77: | 2479 MHz  |
| Channel 18: | 2420 MHz  | Channel 38: | 2440 MHz  | Channel 58: | 2460 MHz  | Channel 78: | 2480 MHz  |
| Channel 19: | 2421 MHz  | Channel 39: | 2441 MHz  | Channel 59: | 2461 MHz  |             |           |

## Note:

1. This device is a Play-Fi Player, Contains functions and so on WiFi 、Bluetooth , This report for Bluetooth.
2. These tests were conducted on a sample for the purpose of demonstrating compliance of Bluetooth transmitter with Part 15 Subpart C Paragraph 15.247 for spread spectrum devices.
3. Regarding to the operation frequency, the lowest, middle and highest frequency are selected to perform the test.

|           |   |
|-----------|---|
| Test Mode | Mode 1: Transmit - 1Mbps (GFSK)<br>Mode 2: Transmit - 3Mbps (8DPSK) |
|-----------|---|

### 1.3. Tested System Details

The types for all equipment, plus descriptions of all cables used in the tested system (including inserted cards) are:

|   | Product               | Manufacturer | Model No. | Serial No.   | Power Cord         |
|---|-----------------------|--------------|-----------|--------------|--------------------|
| 1 | USB Dongle            | Kamera       | N/A       | N/A          | N/A                |
| 2 | Test Fixture          | Lite-On      | N/A       | N/A          | N/A                |
| 3 | Notebook PC           | DELL         | PPT       | N/A          | Non-Shielded, 0.8m |
| 4 | iPod nano             | Apple        | A1236     | 7K823E51Y0P  | N/A                |
| 5 | DVD                   | DELL         | PD01S     | N/A          | N/A                |
| 6 | Microphone & Earphone | PCHOME       | N/A       | N/A          | N/A                |
| 7 | Monitor               | LG           | W2261VT   | 907YHZK07373 | Non-Shielded, 1.8m |

| Signal Cable Type | Signal cable Description                                      |
|-------------------|---|
| A                 | Test Fixture Cable<br>Non-Shielded, 0.2m                      |
| B                 | RS-232 Cable<br>Non-Shielded, 2.0m                            |
| C                 | iPod nano Cable<br>Non-Shielded, 1.8m                         |
| D                 | DVD Cable<br>Non-Shielded, 0.5m                               |
| E                 | Microphone & Earphone Cable<br>Non-Shielded, 1.2m             |
| F                 | D-SUB Cable<br>Shielded, 1.8m, with two ferrite cores bonded. |
| G                 | USB Cable<br>Non-Shielded, 1.0m                               |

### 1.4. Configuration of Tested System

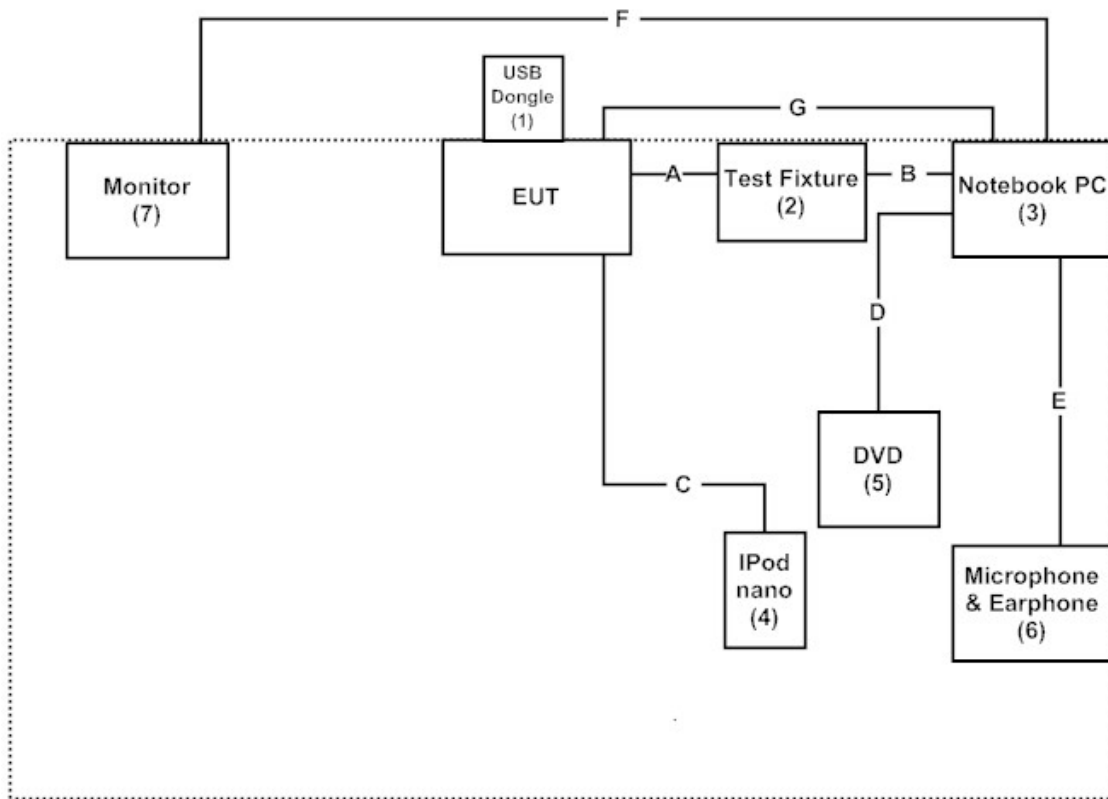

### 1.5. EUT Exercise Software

- (1) Setup the EUT as shown in Section 1.4.
- (2) Execute program on the Notebook.
- (3) Configure the test mode, the test channel, and the data rate.
- (4) Press “OK” to start the continuous Transmit.
- (5) Verify that the EUT works properly.



## 1.6. Test Facility

Ambient conditions in the laboratory:

| Items                      | Required (IEC 68-1) | Actual   |
|----------------------------|---------------------|----------|
| Temperature (°C)           | 15-35               | 20-35    |
| Humidity (%RH)             | 25-75               | 30-65    |
| Barometric pressure (mbar) | 860-1060            | 950-1000 |

The related certificate for our laboratories about the test site and management system can be downloaded from Quietek Corporation's Web Site: <http://www.quietek.com/tw/ctg/cts/accreditations.htm>  
The address and introduction of Quietek Corporation's laboratories can be founded in our Web site: <http://www.quietek.com/>

Site Description: File on  
Federal Communications Commission  
FCC Engineering Laboratory  
7435 Oakland Mills Road  
Columbia, MD 21046  
Registration Number: 92195

Accreditation on NVLAP  
NVLAP Lab Code: 200533-0

Site Name: Quietek Corporation  
Site Address: No.5-22, Ruishukeng,  
Linkou Dist. New Taipei City 24451,  
Taiwan, R.O.C.  
TEL: 886-2-8601-3788 / FAX : 886-2-8601-3789  
E-Mail : [service@quietek.com](mailto:service@quietek.com)

FCC Accreditation Number: TW1014

## 2. Conducted Emission

### 2.1. Test Equipment

|   | Equipment                | Manufacturer | Model No. / Serial No. | Last Cal.  | Remark      |
|---|--------------------------|--------------|------------------------|------------|-------------|
| X | Test Receiver            | R & S        | ESCS 30 / 825442/018   | Sep., 2011 |             |
| X | Artificial Mains Network | R & S        | ENV4200 / 848411/10    | Feb., 2012 | Peripherals |
| X | LISN                     | R & S        | ESH3-Z5 / 825562/002   | Feb., 2012 | EUT         |
|   | DC LISN                  | Schwarzbeck  | 8226 / 176             | Mar, 2012  | EUT         |
| X | Pulse Limiter            | R & S        | ESH3-Z2 / 357.8810.52  | Feb., 2012 |             |
|   | No.1 Shielded Room       |              |                        |            |             |

Note:

1. All equipments are calibrated every one year.
2. The test instruments marked by “X” are used to measure the final test results.

### 2.2. Test Setup

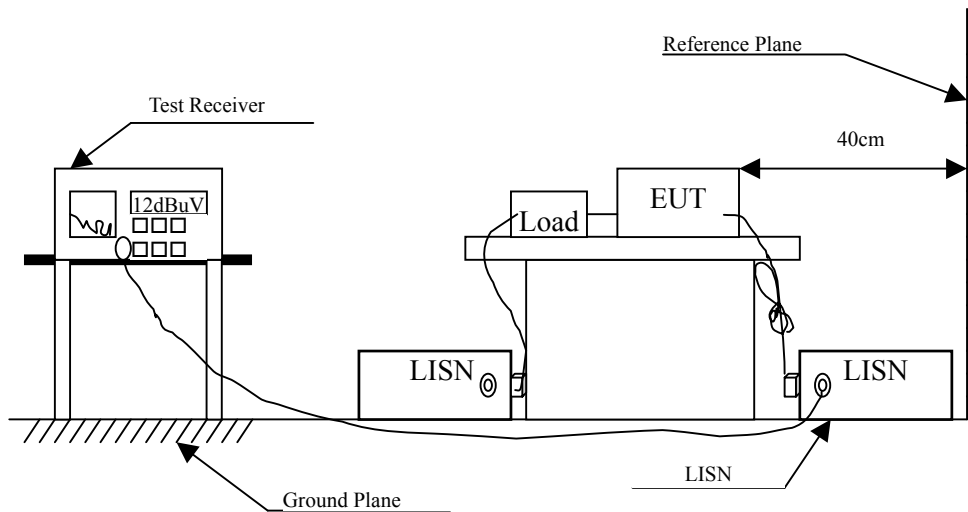

**2.3. Limits**

| <b>FCC Part 15 Subpart C Paragraph 15.207 (dBuV) Limit</b> |        |       |
|--|--------|-------|
| Frequency<br>MHz   | Limits |       |
|  | QP     | AV    |
| 0.15 - 0.50  | 66-56  | 56-46 |
| 0.50-5.0   | 56     | 46    |
| 5.0 - 30   | 60     | 50    |

Remarks: In the above table, the tighter limit applies at the band edges.

**2.4. Test Procedure**

The EUT and Peripherals are connected to the main power through a line impedance stabilization network (L.I.S.N.). This provides a 50 ohm /50uH coupling impedance for the measuring equipment. The peripheral devices are also connected to the main power through a LISN that provides a 50ohm /50uH coupling impedance with 50ohm termination. (Please refer to the block diagram of the test setup and photographs.)

Both sides of A.C. line are checked for maximum conducted interference. In order to find the maximum emission, the relative positions of equipment and all the interface cables must be changed according to ANSI C63.4: 2003 on conducted measurement.

Conducted emissions were investigated over the frequency range from 0.15MHz to 30MHz using a receiver bandwidth of 9kHz.

The EUT was setup to ANSI C63.4, 2003; tested to FHSS test procedure of FCC Public Notice DA 00-705 for compliance to FCC 47CFR 15.247 requirements.

**2.5. Uncertainty**

± 2.26 dB

## 2.6. Test Result of Conducted Emission

Product : Play-Fi Player  
 Test Item : Conducted Emission Test  
 Power Line : Line 1  
 Test Mode : Mode 2: Transmit - 3Mbps (8DPSK) (2441MHz)

| Frequency<br>MHz  | Correct<br>Factor<br>dB | Reading<br>Level<br>dBuV | Measurement<br>Level<br>dBuV | Margin<br>dB | Limit<br>dBuV |
|-------------------|-------------------------|--------------------------|------------------------------|--------------|---------------|
| <b>LINE 1</b>     |                         |                          |                              |              |               |
| <b>Quasi-Peak</b> |                         |                          |                              |              |               |
| 0.166             | 9.711                   | 29.310                   | 39.021                       | -26.522      | 65.543        |
| 0.224             | 9.839                   | 29.820                   | 39.659                       | -24.227      | 63.886        |
| 0.470             | 9.807                   | 39.130                   | 48.937                       | -7.920       | 56.857        |
| 0.763             | 9.820                   | 21.900                   | 31.720                       | -24.280      | 56.000        |
| 6.189             | 9.892                   | 22.420                   | 32.312                       | -27.688      | 60.000        |
| 11.576            | 10.068                  | 18.860                   | 28.928                       | -31.072      | 60.000        |
| <b>Average</b>    |                         |                          |                              |              |               |
| 0.166             | 9.711                   | 16.300                   | 26.011                       | -29.532      | 55.543        |
| 0.224             | 9.839                   | 28.020                   | 37.859                       | -16.027      | 53.886        |
| 0.470             | 9.807                   | 29.580                   | 39.387                       | -7.470       | 46.857        |
| 0.763             | 9.820                   | 15.170                   | 24.990                       | -21.010      | 46.000        |
| 6.189             | 9.892                   | 16.480                   | 26.372                       | -23.628      | 50.000        |
| 11.576            | 10.068                  | 12.040                   | 22.108                       | -27.892      | 50.000        |

Note:

1. All Reading Levels are Quasi-Peak and average value.
2. "█" means the worst emission level.
3. Measurement Level = Reading Level + Correct Factor

Product : Play-Fi Player  
 Test Item : Conducted Emission Test  
 Power Line : Line 2  
 Test Mode : Mode 2: Transmit - 3Mbps (8DPSK) (2441MHz)

| Frequency<br>MHz  | Correct<br>Factor<br>dB | Reading<br>Level<br>dBuV | Measurement<br>Level<br>dBuV | Margin<br>dB | Limit<br>dBuV |
|-------------------|-------------------------|--------------------------|------------------------------|--------------|---------------|
| <b>LINE 2</b>     |                         |                          |                              |              |               |
| <b>Quasi-Peak</b> |                         |                          |                              |              |               |
| 0.177             | 9.778                   | 30.940                   | 40.718                       | -24.511      | 65.229        |
| 0.224             | 9.771                   | 30.000                   | 39.771                       | -24.115      | 63.886        |
| 0.361             | 9.800                   | 28.670                   | 38.470                       | -21.501      | 59.971        |
| 0.420             | 9.817                   | 35.450                   | 45.267                       | -13.019      | 58.286        |
| 6.048             | 9.890                   | 22.670                   | 32.560                       | -27.440      | 60.000        |
| 11.341            | 10.083                  | 16.660                   | 26.743                       | -33.257      | 60.000        |
| <b>Average</b>    |                         |                          |                              |              |               |
| 0.177             | 9.778                   | 18.950                   | 28.728                       | -26.501      | 55.229        |
| 0.224             | 9.771                   | 28.120                   | 37.891                       | -15.995      | 53.886        |
| 0.361             | 9.800                   | 20.860                   | 30.660                       | -19.311      | 49.971        |
| 0.420             | 9.817                   | 27.990                   | 37.807                       | -10.479      | 48.286        |
| 6.048             | 9.890                   | 17.150                   | 27.040                       | -22.960      | 50.000        |
| 11.341            | 10.083                  | 10.320                   | 20.403                       | -29.597      | 50.000        |

Note:

1. All Reading Levels are Quasi-Peak and average value.
2. "█" means the worst emission level.
3. Measurement Level = Reading Level + Correct Factor

**3. Peak Power Output**

**3.1. Test Equipment**

|   | Equipment    | Manufacturer | Model No./Serial No. | Last Cal. |
|---|--------------|--------------|----------------------|-----------|
| X | Power Meter  | Anritsu      | ML2495A/6K00003357   | May, 2011 |
| X | Power Sensor | Anritsu      | MA2411B/0738448      | Jun, 2011 |

Note: 1. All equipments are calibrated every one year.  
 2. The test instruments marked by “X” are used to measure the final test results.

**3.2. Test Setup**

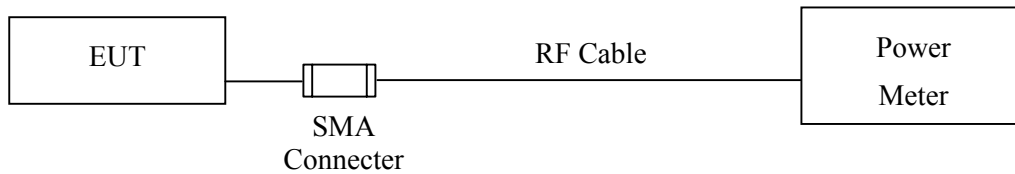

**3.3. Limit**

The maximum peak power shall be less 1Watt.

**3.4. Test Procedure**

The EUT was setup to ANSI C63.4, 2003; tested to FHSS test procedure of FCC Public Notice DA 00-705 for compliance to FCC 47CFR 15.247 requirements.

**3.5. Uncertainty**

± 1.27 dB

### 3.6. Test Result of Peak Power Output

Product : Play-Fi Player  
Test Item : Peak Power Output  
Test Site : No.3 OATS  
Test Mode : Mode 1: Transmit - 1Mbps (GFSK)

| Channel No. | Frequency (MHz) | Measurement (dBm) | Required Limit | Result |
|-------------|-----------------|-------------------|----------------|--------|
| Channel 00  | 2402.00         | 5.10              | 1 Watt= 30 dBm | Pass   |
| Channel 39  | 2441.00         | 4.59              | 1 Watt= 30 dBm | Pass   |
| Channel 78  | 2480.00         | 4.70              | 1 Watt= 30 dBm | Pass   |

Product : Play-Fi Player  
Test Item : Peak Power Output  
Test Site : No.3 OATS  
Test Mode : Mode 2: Transmit - 3Mbps (8DPSK)

| Channel No. | Frequency<br>(MHz) | Measurement<br>(dBm) | Required Limit | Result |
|-------------|--------------------|----------------------|----------------|--------|
| Channel 00  | 2402.00            | 4.51                 | 1 Watt= 30 dBm | Pass   |
| Channel 39  | 2441.00            | 3.86                 | 1 Watt= 30 dBm | Pass   |
| Channel 78  | 2480.00            | 3.82                 | 1 Watt= 30 dBm | Pass   |



#### 4. Radiated Emission

##### 4.1. Test Equipment

The following test equipments are used during the radiated emission test:

| Test Site  |   | Equipment         | Manufacturer    | Model No./Serial No.  | Last Cal.  |
|------------|---|-------------------|-----------------|-----------------------|------------|
| ☒ Site # 3 | X | Bilog Antenna     | Schaffner Chase | CBL6112B/2673         | Sep., 2011 |
|            | X | Horn Antenna      | Schwarzbeck     | BBHA9120D/D305        | Sep., 2011 |
|            | X | Horn Antenna      | Schwarzbeck     | BBHA9170/208          | Jul., 2011 |
|            | X | Pre-Amplifier     | Agilent         | 8447D/2944A09549      | Sep., 2011 |
|            | X | Spectrum Analyzer | Agilent         | E4407B / US39440758   | May, 2011  |
|            | X | Test Receiver     | R & S           | ESCS 30/ 825442/018   | Sep., 2011 |
|            | X | Coaxial Cable     | Quietek         | QTK-CABLE/ CAB5       | Feb., 2012 |
|            | X | Controller        | Quietek         | QTK-CONTROLLER/ CTRL3 | N/A        |
|            | X | Coaxial Switch    | Anritsu         | MP59B/6200265729      | N/A        |

- Note: 1. All equipments are calibrated every one year.  
 2. The test instruments marked by "X" are used to measure the final test results.

##### 4.2. Test Setup

Below 1GHz

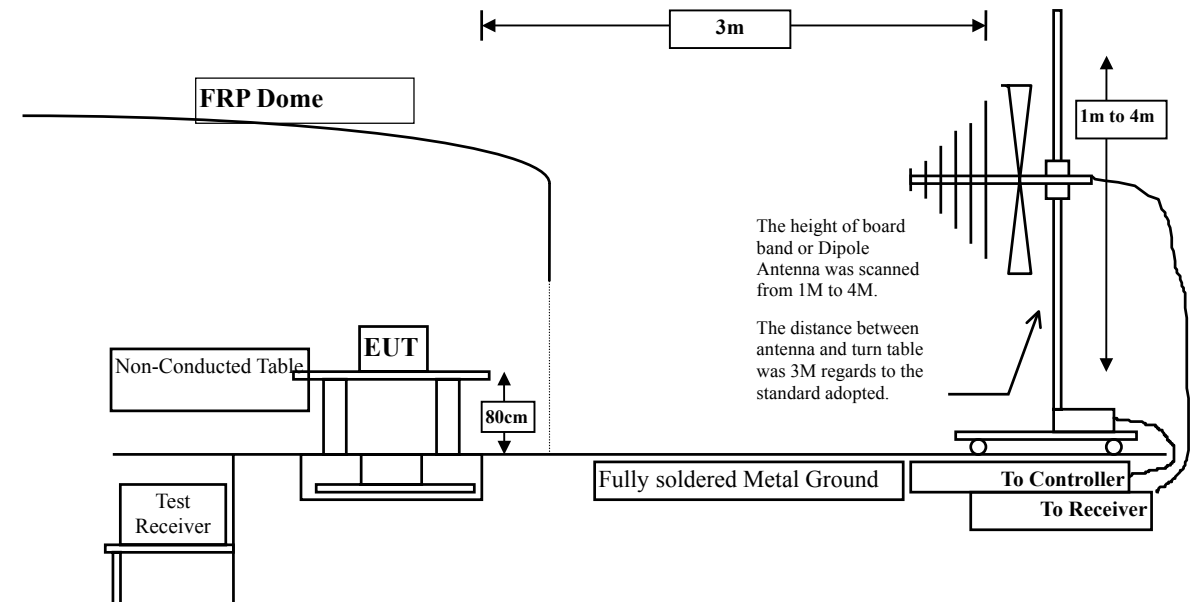

Above 1GHz

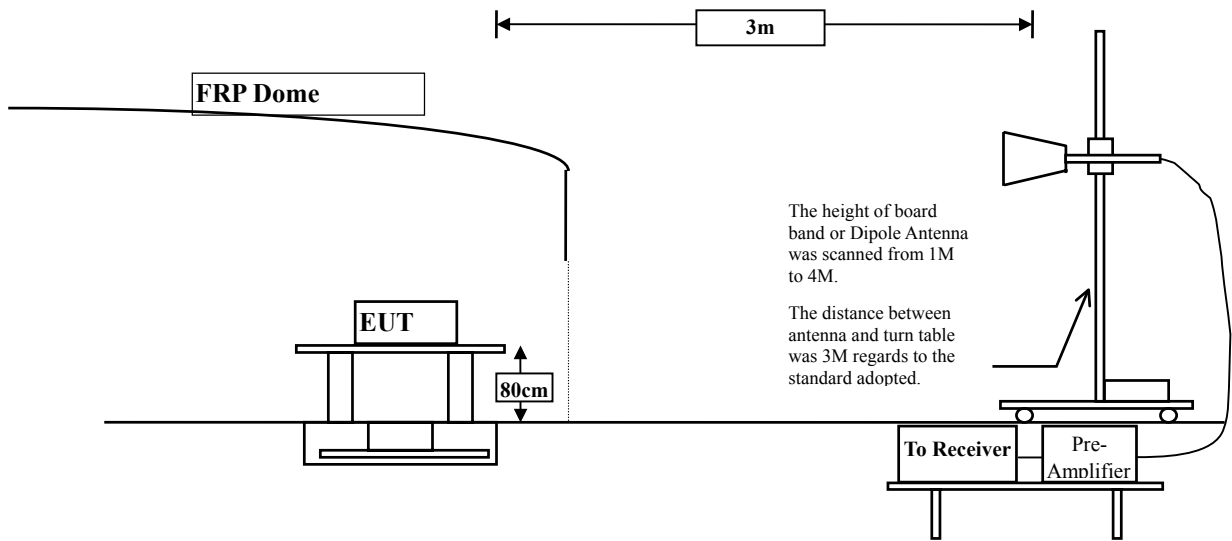

### 4.3. Limits

#### ➤ General Radiated Emission Limits

Emissions radiated outside of the specified frequency bands, except for harmonics, shall be attenuated by at least 20dB below the level of the fundamental or to the general radiated emission limits in paragraph 15.209, whichever is the lesser attenuation.

| FCC Part 15 Subpart C Paragraph 15.209 Limits |          |           |
|---|----------|-----------|
| Frequency MHz                                 | uV/m @3m | dBuV/m@3m |
| 30-88   | 100      | 40        |
| 88-216  | 150      | 43.5      |
| 216-960                                       | 200      | 46        |
| Above 960                                     | 500      | 54        |

- Remarks:
1. RF Voltage (dBuV) = 20 log RF Voltage (uV)
  2. In the Above Table, the tighter limit applies at the band edges.
  3. Distance refers to the distance in meters between the measuring instrument antenna and the closed point of any part of the device or system.

#### 4.4. Test Procedure

The EUT was setup according to ANSI C63.4, 2003 and tested according to FHSS test procedure of FCC Public Notice DA 00-705 for compliance to FCC 47CFR 15.247 requirements.

The EUT is placed on a turn table which is 0.8 meter above ground. The turn table is rotated 360 degrees to determine the position of the maximum emission level. The EUT was positioned such that the distance from antenna to the EUT was 3 meters.

The antenna is scanned from 1 meter to 4 meters to find out the maximum emission level. This is repeated for both horizontal and vertical polarization of the antenna. In order to find the maximum emission, all of the interface cables were manipulated according to ANSI C63.4:2003 on radiated measurement.

The resolution bandwidth below 1GHz setting on the field strength meter is 120 kHz and above 1GHz is 1MHz.

Radiated emission measurements below 1GHz are made using broadband Bilog antenna and above 1GHz are made using Horn Antennas.

The measurement is divided into the Preliminary Measurement and the Final Measurement.

The suspected frequencies are searched for in Preliminary Measurement with the measurement antenna kept pointed at the source of the emission both in azimuth and elevation, with the polarization of the antenna oriented for maximum response. The antenna is pointed at an angle towards the source of the emission, and the EUT is rotated in both height and polarization to maximize the measured emission. The emission is kept within the illumination area of the 3 dB bandwidth of the antenna.

The worst radiated emission is measured on the Final Measurement.

The measurement frequency range form 30MHz - 10th Harmonic of fundamental was investigated.

#### 4.5. Uncertainty

± 3.9 dB above 1GHz

± 3.8 dB below 1GHz

#### 4.6. Test Result of Radiated Emission

Product : Play-Fi Player  
 Test Item : Harmonic Radiated Emission  
 Test Site : No.3 OATS  
 Test Mode : Mode 1: Transmit - 1Mbps (GFSK)(2402MHz)

| Frequency<br>MHz             | Correct<br>Factor<br>dB | Reading<br>Level<br>dBuV | Measurement<br>Level<br>dBuV/m | Margin<br>dB | Limit<br>dBuV/m |
|------------------------------|-------------------------|--------------------------|--------------------------------|--------------|-----------------|
| <b>Horizontal</b>            |                         |                          |                                |              |                 |
| <b>Peak Detector:</b>        |                         |                          |                                |              |                 |
| 4804.000                     | 3.327                   | 47.090                   | 50.417                         | -23.583      | 74.000          |
| 7206.000                     | 10.136                  | 37.990                   | 48.126                         | -25.874      | 74.000          |
| 9608.000                     | 13.706                  | 36.960                   | 50.666                         | -23.334      | 74.000          |
| <b>Average<br/>Detector:</b> |                         |                          |                                |              |                 |
| --                           |                         |                          |                                |              |                 |
| <b>Vertical</b>              |                         |                          |                                |              |                 |
| <b>Peak Detector:</b>        |                         |                          |                                |              |                 |
| 4804.000                     | 6.638                   | 48.520                   | 55.157                         | -18.843      | 74.000          |
| 7206.000                     | 11.005                  | 37.890                   | 48.895                         | -25.105      | 74.000          |
| 9608.000                     | 14.103                  | 36.560                   | 50.663                         | -23.337      | 74.000          |
| <b>Average<br/>Detector:</b> |                         |                          |                                |              |                 |
| 4804.000                     | 6.638                   | 39.910                   | 46.547                         | -7.453       | 54.000          |

Note:

1. All Readings below 1GHz are Quasi-Peak, above 1GHz are performed with peak and/or average measurements as necessary.
2. Peak measurements: RBW = 1MHz, VBW = 3 MHz, Sweep: Auto.
3. Average measurements: RBW = 1MHz, VBW = 10 Hz, Sweep: Auto.
4. Measurement Level = Reading Level + Correct Factor.
5. Correct Factor = Antenna factor + Cable loss – Amplifier gain.
6. The average measurement was not performed when the peak measured data under the limit of average detection.
7. The emission levels of other frequencies are very lower than the limit and not show in test report.

Product : Play-Fi Player  
 Test Item : Harmonic Radiated Emission  
 Test Site : No.3 OATS  
 Test Mode : Mode 1: Transmit - 1Mbps (GFSK)(2441MHz)

| Frequency<br>MHz             | Correct<br>Factor<br>dB | Reading<br>Level<br>dBuV | Measurement<br>Level<br>dBuV/m | Margin<br>dB | Limit<br>dBuV/m |
|------------------------------|-------------------------|--------------------------|--------------------------------|--------------|-----------------|
| <b>Horizontal</b>            |                         |                          |                                |              |                 |
| <b>Peak Detector:</b>        |                         |                          |                                |              |                 |
| 4882.000                     | 3.001                   | 45.180                   | 48.181                         | -25.819      | 74.000          |
| 7323.000                     | 11.846                  | 39.670                   | 51.517                         | -22.483      | 74.000          |
| 9764.000                     | 12.563                  | 39.990                   | 52.553                         | -21.447      | 74.000          |
| <b>Average<br/>Detector:</b> |                         |                          |                                |              |                 |
| --                           |                         |                          |                                |              |                 |
| <b>Vertical</b>              |                         |                          |                                |              |                 |
| <b>Peak Detector:</b>        |                         |                          |                                |              |                 |
| 4882.000                     | 5.713                   | 47.820                   | 53.534                         | -20.466      | 74.000          |
| 7323.000                     | 12.727                  | 37.890                   | 50.618                         | -23.382      | 74.000          |
| 9764.000                     | 13.028                  | 36.950                   | 49.978                         | -24.022      | 74.000          |
| <b>Average<br/>Detector:</b> |                         |                          |                                |              |                 |
| --                           |                         |                          |                                |              |                 |

Note:

1. All Readings below 1GHz are Quasi-Peak, above 1GHz are performed with peak and/or average measurements as necessary.
2. Peak measurements: RBW = 1MHz, VBW = 3 MHz, Sweep: Auto.
3. Average measurements: RBW = 1MHz, VBW = 10 Hz, Sweep: Auto.
4. Measurement Level = Reading Level + Correct Factor.
5. Correct Factor = Antenna factor + Cable loss – Amplifier gain.
6. The average measurement was not performed when the peak measured data under the limit of average detection.
7. The emission levels of other frequencies are very lower than the limit and not show in test report.

Product : Play-Fi Player  
 Test Item : Harmonic Radiated Emission  
 Test Site : No.3 OATS  
 Test Mode : Mode 1: Transmit - 1Mbps (GFSK)(2480MHz)

| Frequency<br>MHz             | Correct<br>Factor<br>dB | Reading<br>Level<br>dBuV | Measurement<br>Level<br>dBuV/m | Margin<br>dB | Limit<br>dBuV/m |
|------------------------------|-------------------------|--------------------------|--------------------------------|--------------|-----------------|
| <b>Horizontal</b>            |                         |                          |                                |              |                 |
| <b>Peak Detector:</b>        |                         |                          |                                |              |                 |
| 4960.000                     | 2.760                   | 43.190                   | 45.950                         | -28.050      | 74.000          |
| 7440.000                     | 12.567                  | 39.080                   | 51.646                         | -22.354      | 74.000          |
| 9920.000                     | 13.456                  | 36.500                   | 49.956                         | -24.044      | 74.000          |
| <b>Average<br/>Detector:</b> |                         |                          |                                |              |                 |
| --                           |                         |                          |                                |              |                 |
| <b>Vertical</b>              |                         |                          |                                |              |                 |
| <b>Peak Detector:</b>        |                         |                          |                                |              |                 |
| 4960.000                     | 5.557                   | 45.100                   | 50.657                         | -23.343      | 74.000          |
| 7440.000                     | 13.426                  | 38.240                   | 51.665                         | -22.335      | 74.000          |
| 9920.000                     | 13.958                  | 36.320                   | 50.278                         | -23.722      | 74.000          |
| <b>Average<br/>Detector:</b> |                         |                          |                                |              |                 |
| --                           |                         |                          |                                |              |                 |

Note:

1. All Readings below 1GHz are Quasi-Peak, above 1GHz are performed with peak and/or average measurements as necessary.
2. Peak measurements: RBW = 1MHz, VBW = 3 MHz, Sweep: Auto.
3. Average measurements: RBW = 1MHz, VBW = 10 Hz, Sweep: Auto.
4. Measurement Level = Reading Level + Correct Factor.
5. Correct Factor = Antenna factor + Cable loss – Amplifier gain.
6. The average measurement was not performed when the peak measured data under the limit of average detection.
7. The emission levels of other frequencies are very lower than the limit and not show in test report.

Product : Play-Fi Player  
 Test Item : Harmonic Radiated Emission  
 Test Site : No.3 OATS  
 Test Mode : Mode 2: Transmit - 3Mbps (8DPSK)(2402MHz)

| Frequency<br>MHz             | Correct<br>Factor<br>dB | Reading<br>Level<br>dBuV | Measurement<br>Level<br>dBuV/m | Margin<br>dB | Limit<br>dBuV/m |
|------------------------------|-------------------------|--------------------------|--------------------------------|--------------|-----------------|
| <b>Horizontal</b>            |                         |                          |                                |              |                 |
| <b>Peak Detector:</b>        |                         |                          |                                |              |                 |
| 4804.000                     | 3.327                   | 42.470                   | 45.797                         | -28.203      | 74.000          |
| 7206.000                     | 10.136                  | 36.400                   | 46.536                         | -27.464      | 74.000          |
| 9608.000                     | 13.706                  | 35.710                   | 49.416                         | -24.584      | 74.000          |
| <b>Average<br/>Detector:</b> |                         |                          |                                |              |                 |
| --                           |                         |                          |                                |              |                 |
| <b>Vertical</b>              |                         |                          |                                |              |                 |
| <b>Peak Detector:</b>        |                         |                          |                                |              |                 |
| 4804.000                     | 6.638                   | 44.660                   | 51.297                         | -22.703      | 74.000          |
| 7206.000                     | 11.005                  | 36.310                   | 47.315                         | -26.685      | 74.000          |
| 9608.000                     | 14.103                  | 35.670                   | 49.773                         | -24.227      | 74.000          |
| <b>Average<br/>Detector:</b> |                         |                          |                                |              |                 |
| --                           |                         |                          |                                |              |                 |

Note:

1. All Readings below 1GHz are Quasi-Peak, above 1GHz are performed with peak and/or average measurements as necessary.
2. Peak measurements: RBW = 1MHz, VBW = 3 MHz, Sweep: Auto.
3. Average measurements: RBW = 1MHz, VBW = 10 Hz, Sweep: Auto.
4. Measurement Level = Reading Level + Correct Factor.
5. Correct Factor = Antenna factor + Cable loss – Amplifier gain.
6. The average measurement was not performed when the peak measured data under the limit of average detection.
7. The emission levels of other frequencies are very lower than the limit and not show in test report.

Product : Play-Fi Player  
 Test Item : Harmonic Radiated Emission  
 Test Site : No.3 OATS  
 Test Mode : Mode 2: Transmit - 3Mbps (8DPSK) (2441MHz)

| Frequency<br>MHz             | Correct<br>Factor<br>dB | Reading<br>Level<br>dBuV | Measurement<br>Level<br>dBuV/m | Margin<br>dB | Limit<br>dBuV/m |
|------------------------------|-------------------------|--------------------------|--------------------------------|--------------|-----------------|
| <b>Horizontal</b>            |                         |                          |                                |              |                 |
| <b>Peak Detector:</b>        |                         |                          |                                |              |                 |
| 4882.000                     | 3.001                   | 40.820                   | 43.821                         | -30.179      | 74.000          |
| 7323.000                     | 11.846                  | 35.030                   | 46.877                         | -27.123      | 74.000          |
| 9764.000                     | 12.563                  | 37.170                   | 49.733                         | -24.267      | 74.000          |
| <b>Average<br/>Detector:</b> |                         |                          |                                |              |                 |
| --                           |                         |                          |                                |              |                 |
| <b>Vertical</b>              |                         |                          |                                |              |                 |
| <b>Peak Detector:</b>        |                         |                          |                                |              |                 |
| 4882.000                     | 5.713                   | 43.940                   | 49.654                         | -24.346      | 74.000          |
| 7323.000                     | 12.727                  | 35.320                   | 48.048                         | -25.952      | 74.000          |
| 9764.000                     | 13.028                  | 35.970                   | 48.998                         | -25.002      | 74.000          |
| <b>Average<br/>Detector:</b> |                         |                          |                                |              |                 |
| --                           |                         |                          |                                |              |                 |

Note:

1. All Readings below 1GHz are Quasi-Peak, above 1GHz are performed with peak and/or average measurements as necessary.
2. Peak measurements: RBW = 1MHz, VBW = 3 MHz, Sweep: Auto.
3. Average measurements: RBW = 1MHz, VBW = 10 Hz, Sweep: Auto.
4. Measurement Level = Reading Level + Correct Factor.
5. Correct Factor = Antenna factor + Cable loss – Amplifier gain.
6. The average measurement was not performed when the peak measured data under the limit of average detection.
7. The emission levels of other frequencies are very lower than the limit and not show in test report.



Product : Play-Fi Player  
 Test Item : Harmonic Radiated Emission  
 Test Site : No.3 OATS  
 Test Mode : Mode 2: Transmit - 3Mbps (8DPSK) (2480MHz)

| Frequency<br>MHz             | Correct<br>Factor<br>dB | Reading<br>Level<br>dBuV | Measurement<br>Level<br>dBuV/m | Margin<br>dB | Limit<br>dBuV/m |
|------------------------------|-------------------------|--------------------------|--------------------------------|--------------|-----------------|
| <b>Horizontal</b>            |                         |                          |                                |              |                 |
| <b>Peak Detector:</b>        |                         |                          |                                |              |                 |
| 4960.000                     | 2.760                   | 38.010                   | 40.770                         | -33.230      | 74.000          |
| 7440.000                     | 12.567                  | 34.500                   | 47.066                         | -26.934      | 74.000          |
| 9920.000                     | 13.456                  | 36.270                   | 49.726                         | -24.274      | 74.000          |
| <b>Average<br/>Detector:</b> |                         |                          |                                |              |                 |
| --                           |                         |                          |                                |              |                 |
| <b>Vertical</b>              |                         |                          |                                |              |                 |
| <b>Peak Detector:</b>        |                         |                          |                                |              |                 |
| 4960.000                     | 5.557                   | 41.110                   | 46.667                         | -27.333      | 74.000          |
| 7440.000                     | 13.426                  | 34.980                   | 48.405                         | -25.595      | 74.000          |
| 9920.000                     | 13.958                  | 36.290                   | 50.248                         | -23.752      | 74.000          |
| <b>Average<br/>Detector:</b> |                         |                          |                                |              |                 |
| --                           |                         |                          |                                |              |                 |

Note:

1. All Readings below 1GHz are Quasi-Peak, above 1GHz are performed with peak and/or average measurements as necessary.
2. Peak measurements: RBW = 1MHz, VBW = 3 MHz, Sweep: Auto.
3. Average measurements: RBW = 1MHz, VBW = 10 Hz, Sweep: Auto.
4. Measurement Level = Reading Level + Correct Factor.
5. Correct Factor = Antenna factor + Cable loss – Amplifier gain.
6. The average measurement was not performed when the peak measured data under the limit of average detection.
7. The emission levels of other frequencies are very lower than the limit and not show in test report.

Product : Play-Fi Player  
 Test Item : General Radiated Emission  
 Test Site : No.3 OATS  
 Test Mode : Mode 1: Transmit - 1Mbps (GFSK) (2441MHz)

| Frequency<br>MHz  | Correct<br>Factor<br>dB | Reading<br>Level<br>dBuV | Measurement<br>Level<br>dBuV/m | Margin<br>dB | Limit<br>dBuV/m |
|-------------------|-------------------------|--------------------------|--------------------------------|--------------|-----------------|
| <b>Horizontal</b> |                         |                          |                                |              |                 |
| 253.100           | -5.669                  | 41.272                   | 35.603                         | -10.397      | 46.000          |
| 295.780           | -4.747                  | 41.799                   | 37.052                         | -8.948       | 46.000          |
| 398.600           | 0.879                   | 34.672                   | 35.551                         | -10.449      | 46.000          |
| 540.220           | 3.499                   | 31.047                   | 34.546                         | -11.454      | 46.000          |
| 798.240           | 6.409                   | 34.304                   | 40.712                         | -5.288       | 46.000          |
| 961.200           | 6.810                   | 38.397                   | 45.207                         | -8.793       | 54.000          |
| <b>Vertical</b>   |                         |                          |                                |              |                 |
| 224.000           | -6.379                  | 44.566                   | 38.187                         | -7.813       | 46.000          |
| 311.300           | -4.071                  | 35.036                   | 30.965                         | -15.035      | 46.000          |
| 540.220           | 2.169                   | 27.996                   | 30.165                         | -15.835      | 46.000          |
| 664.380           | -0.978                  | 32.841                   | 31.863                         | -14.137      | 46.000          |
| 798.240           | 2.629                   | 29.263                   | 31.891                         | -14.109      | 46.000          |
| 961.200           | 3.310                   | 34.292                   | 37.602                         | -16.398      | 54.000          |

Note:

1. All Readings below 1GHz are Quasi-Peak, above 1GHz are performed with peak and/or average measurements as necessary.
2. Peak measurements: RBW = 1MHz, VBW = 3 MHz, Sweep: Auto.
3. Average measurements: RBW = 1MHz, VBW = 10 Hz, Sweep: Auto.
4. Measurement Level = Reading Level + Correct Factor.
5. Correct Factor = Antenna factor + Cable loss – Amplifier gain.
6. The average measurement was not performed when the peak measured data under the limit of average detection.
7. The emission levels of other frequencies are very lower than the limit and not show in test report.

Product : Play-Fi Player  
 Test Item : General Radiated Emission  
 Test Site : No.3 OATS  
 Test Mode : Mode 2: Transmit - 3Mbps (8DPSK) (2441MHz)

| Frequency<br>MHz  | Correct<br>Factor<br>dB | Reading<br>Level<br>dBuV | Measurement<br>Level<br>dBuV/m | Margin<br>dB | Limit<br>dBuV/m |
|-------------------|-------------------------|--------------------------|--------------------------------|--------------|-----------------|
| <b>Horizontal</b> |                         |                          |                                |              |                 |
| 251.160           | -5.988                  | 40.153                   | 34.165                         | -11.835      | 46.000          |
| 311.300           | -4.651                  | 38.940                   | 34.289                         | -11.711      | 46.000          |
| 398.600           | 0.879                   | 34.141                   | 35.020                         | -10.980      | 46.000          |
| 540.220           | 3.499                   | 30.536                   | 34.035                         | -11.965      | 46.000          |
| 798.240           | 6.409                   | 34.553                   | 40.961                         | -5.039       | 46.000          |
| 961.200           | 6.810                   | 38.072                   | 44.882                         | -9.118       | 54.000          |
| <b>Vertical</b>   |                         |                          |                                |              |                 |
| 43.580            | -10.919                 | 43.025                   | 32.106                         | -7.894       | 40.000          |
| 289.960           | -5.550                  | 41.497                   | 35.947                         | -10.053      | 46.000          |
| 390.840           | -0.768                  | 34.077                   | 33.309                         | -12.691      | 46.000          |
| 666.320           | -0.951                  | 33.644                   | 32.693                         | -13.307      | 46.000          |
| 798.240           | 2.629                   | 30.904                   | 33.532                         | -12.468      | 46.000          |
| 961.200           | 3.310                   | 35.418                   | 38.728                         | -15.272      | 54.000          |

Note:

- All Readings below 1GHz are Quasi-Peak, above 1GHz are performed with peak and/or average measurements as necessary.
- Peak measurements: RBW = 1MHz, VBW = 3 MHz, Sweep: Auto.
- Average measurements: RBW = 1MHz, VBW = 10 Hz, Sweep: Auto.
- Measurement Level = Reading Level + Correct Factor.
- Correct Factor = Antenna factor + Cable loss – Amplifier gain.
- The average measurement was not performed when the peak measured data under the limit of average detection.
- The emission levels of other frequencies are very lower than the limit and not show in test report.

## 5. RF Antenna Conducted Test

### 5.1. Test Equipment

| Equipment         | Manufacturer | Model No./Serial No. | Last Cal. |
|-------------------|--------------|----------------------|-----------|
| Spectrum Analyzer | R&S          | FSP40 / 100170       | Jun, 2011 |

|   |                   |         |                     |            |
|---|-------------------|---------|---------------------|------------|
|   | Spectrum Analyzer | Agilent | E4407B / US39440758 | Jun, 2011  |
| X | Spectrum Analyzer | Agilent | N9010A / MY48030495 | Apr., 2012 |

- Note: 1. All equipments are calibrated every one year.  
 2. The test instruments Marked “X” are used to measure the final test results.

**5.2. Test Setup**

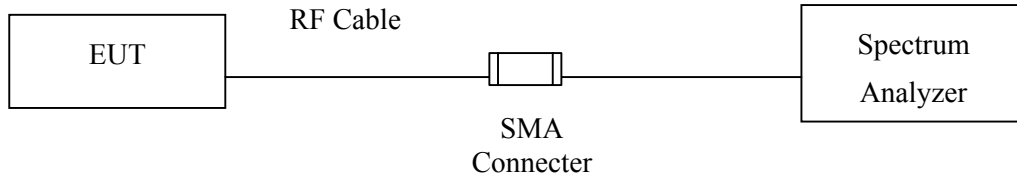

**5.3. Limits**

According to FCC Section 15.247(d). In any 100 kHz bandwidth outside the frequency band in which the spread spectrum or digitally modulated intentional radiator is operating, the radio frequency power that is produced by the intentional radiator shall be at least 20 dB below that in the 100 kHz bandwidth within the band that contains the highest level of the desired power, based on either an RF conducted or measurement, provided the transmitter demonstrates compliance with the peak conducted power limits. If the transmitter complies with the conducted power limits based on the use of RMS averaging over a time interval, the attenuation required under this paragraph shall be 30 dB instead of 20 dB.

**5.4. Test Procedure**

The EUT was setup to ANSI C63.4, 2003; tested to FHSS test procedure of FCC Public Notice DA 00-705 for compliance to FCC 47CFR 15.247 requirements.

**5.5. Uncertainty**

± 150Hz

**5.6. Test Result of RF Antenna Conducted Test**

Product : Play-Fi Player  
 Test Item : RF Antenna Conducted Test  
 Test Site : No.3 OATS  
 Test Mode : Mode 1: Transmit - 1Mbps (GFSK)

**Figure Channel 00:**

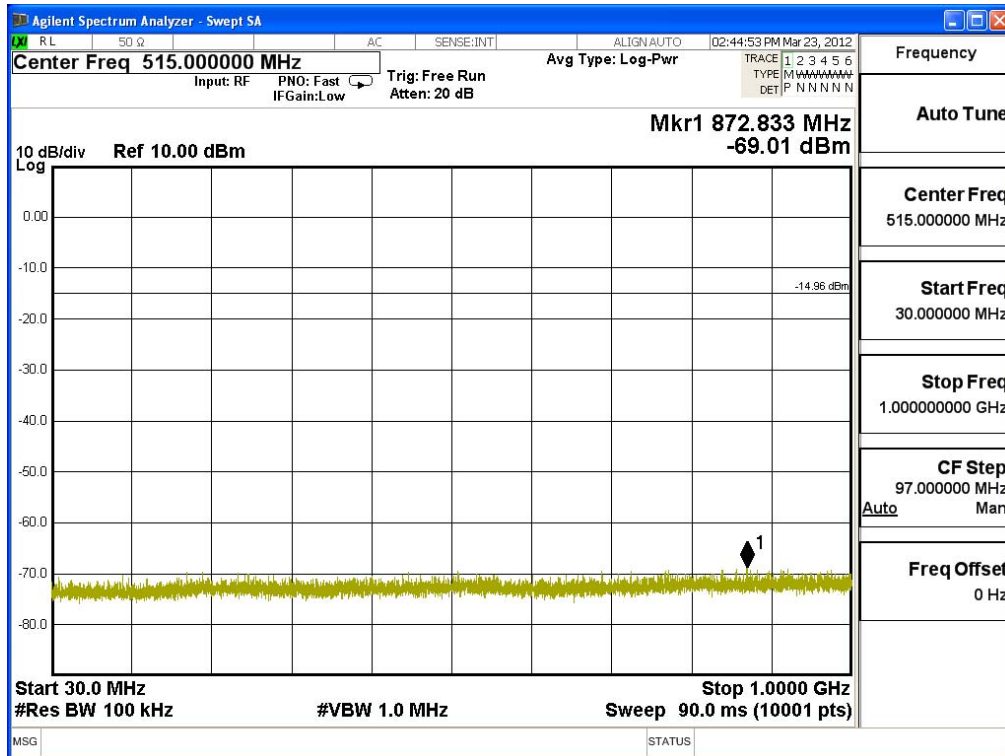

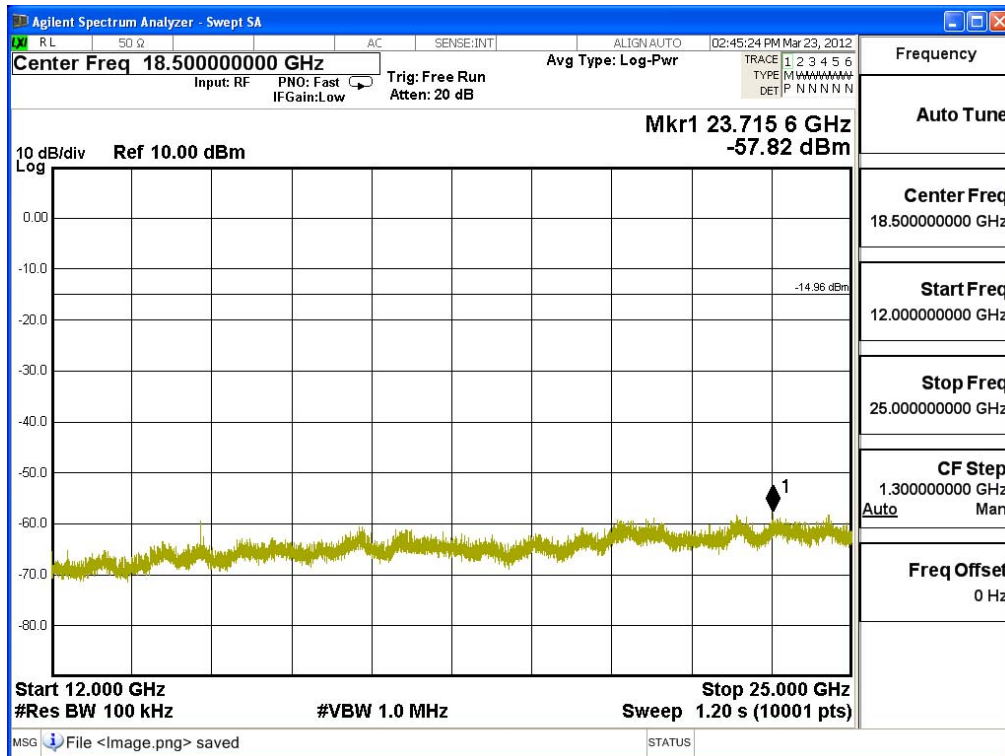
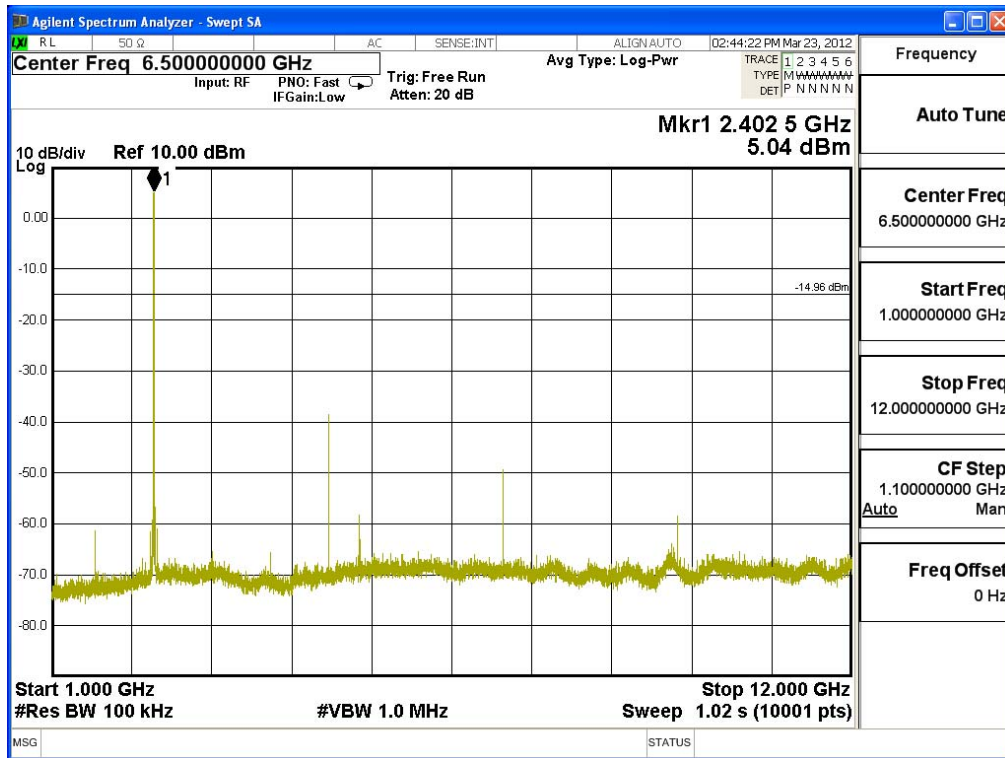

Product : Play-Fi Player  
 Test Item : RF Antenna Conducted Test  
 Test Site : No.3 OATS  
 Test Mode : Mode 1: Transmit - 1Mbps (GFSK)

**Figure Channel 39:**

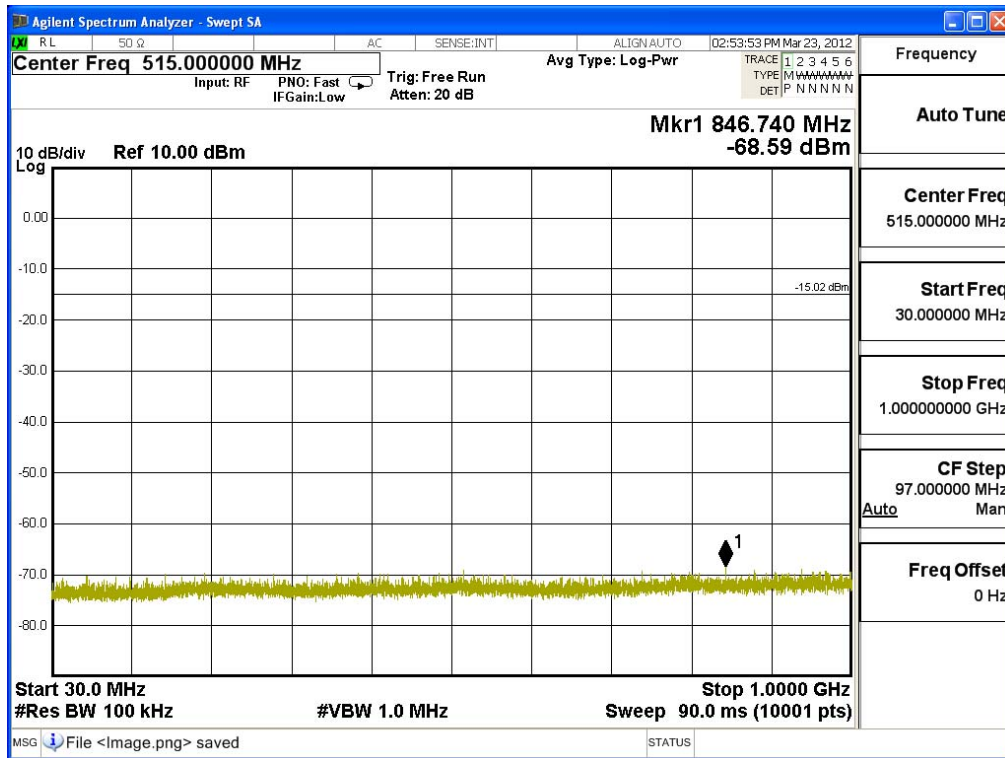

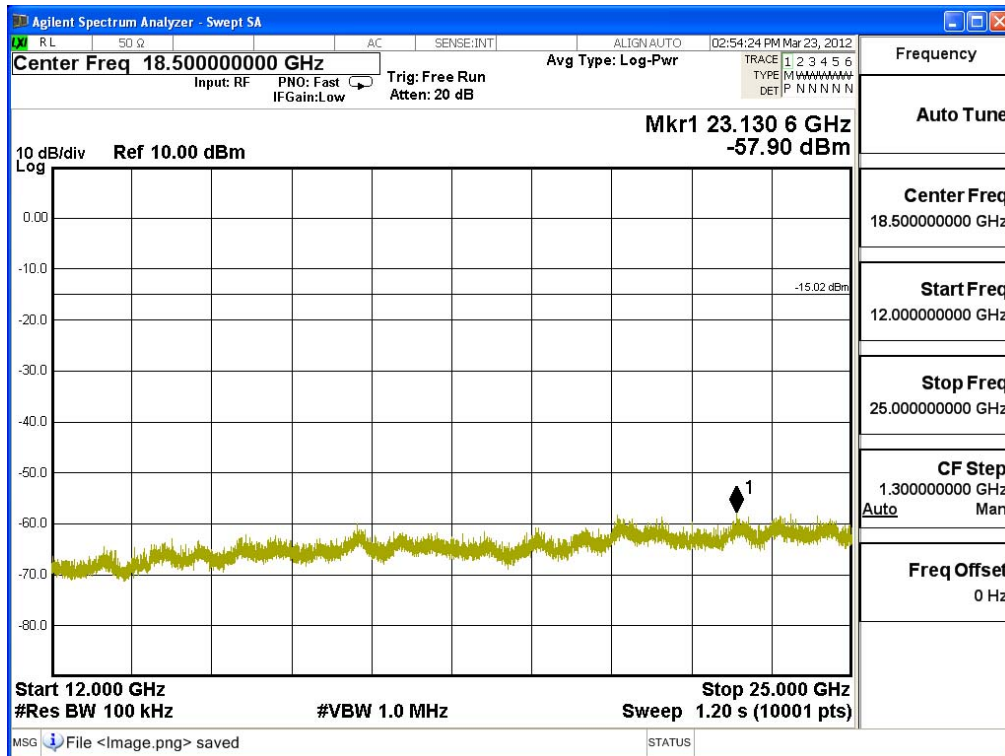
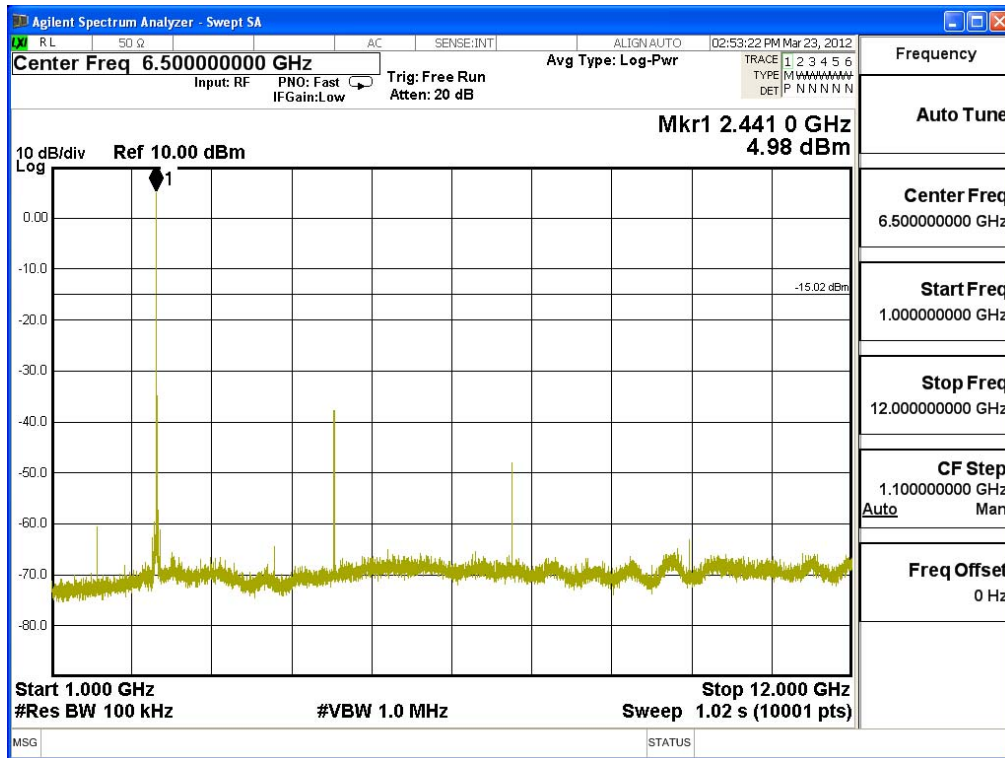



Product : Play-Fi Player  
 Test Item : RF Antenna Conducted Test  
 Test Site : No.3 OATS  
 Test Mode : Mode 1: Transmit - 1Mbps (GFSK)

**Figure Channel 78:**

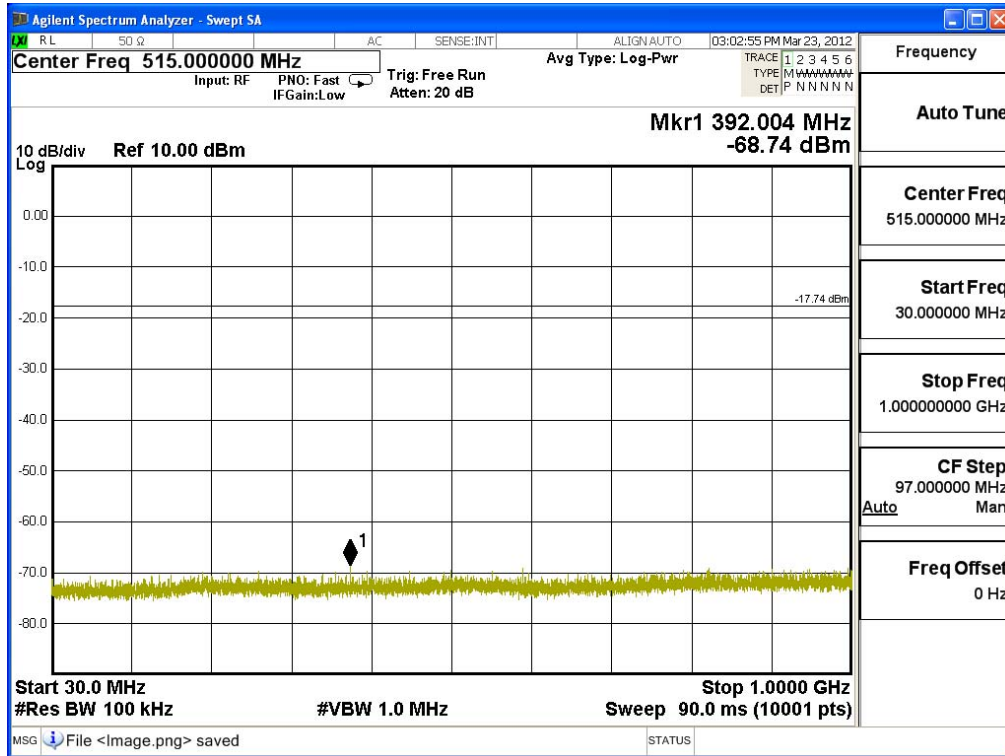

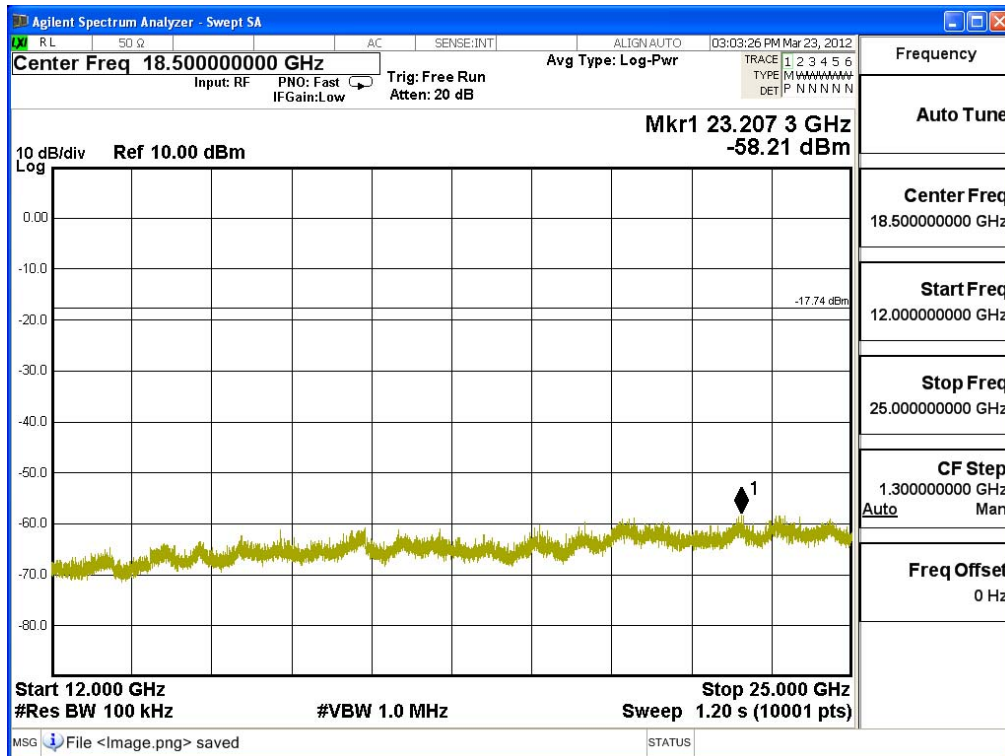
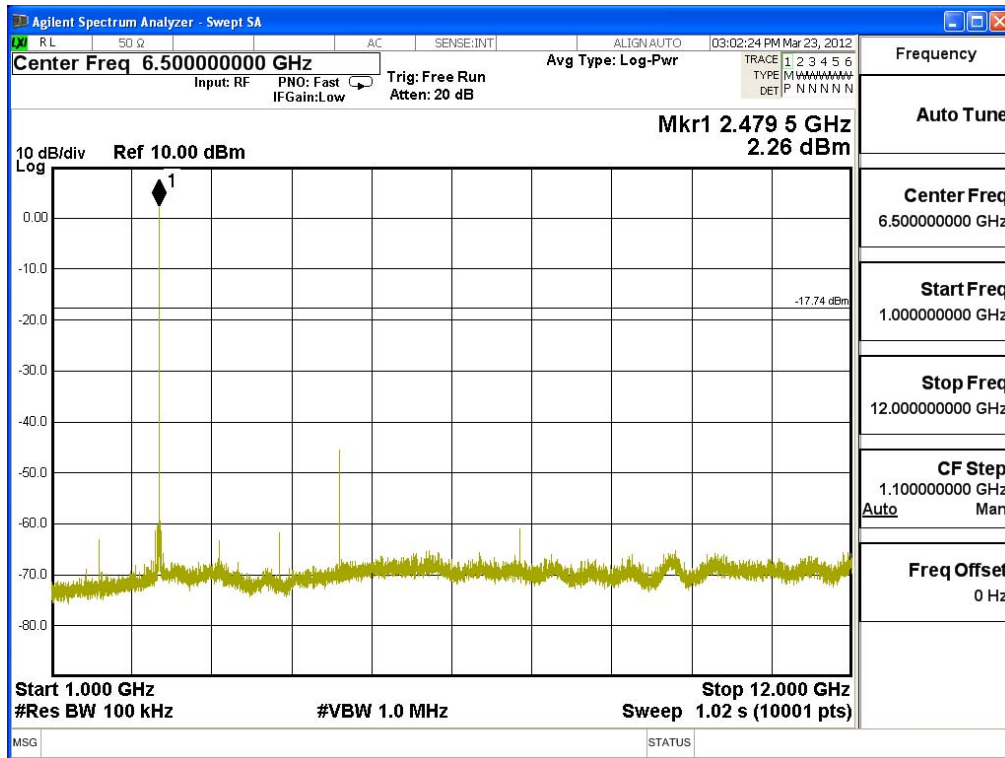

Product : Play-Fi Player  
 Test Item : RF Antenna Conducted Test  
 Test Site : No.3 OATS  
 Test Mode : Mode 2: Transmit - 3Mbps (8DPSK)

**Figure Channel 00:**

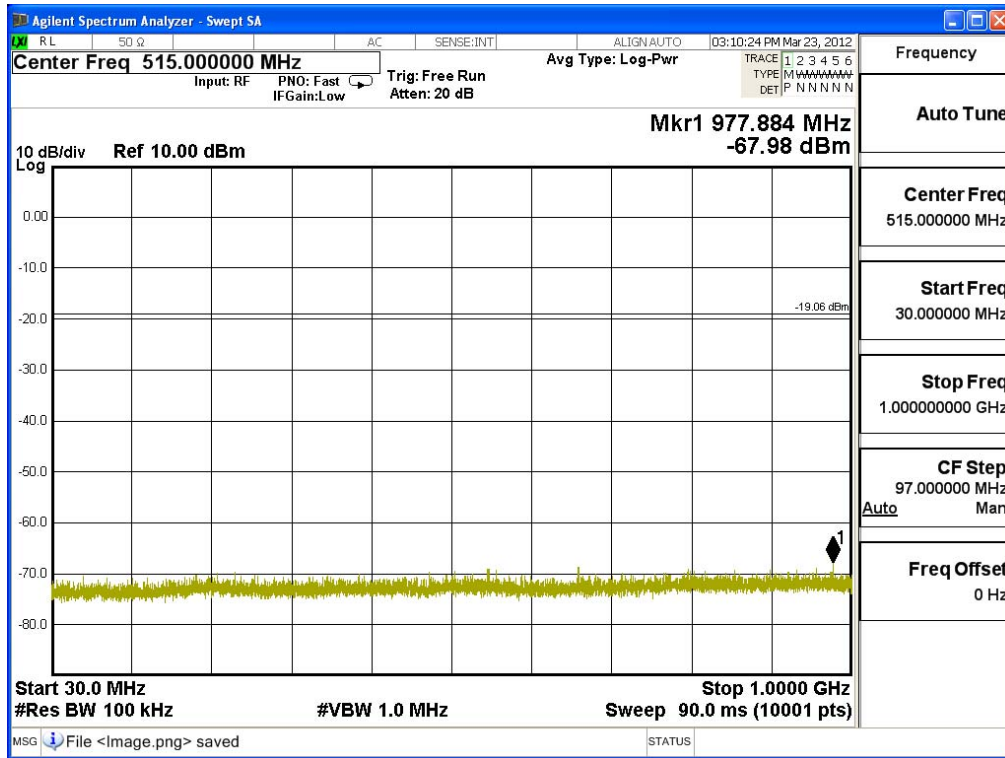

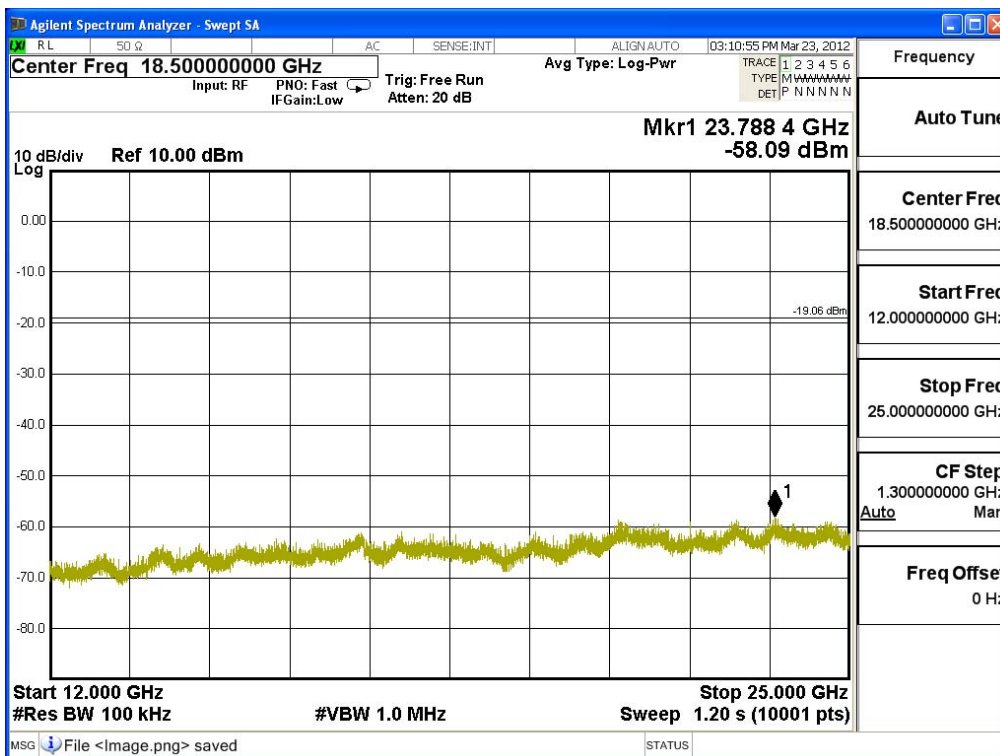
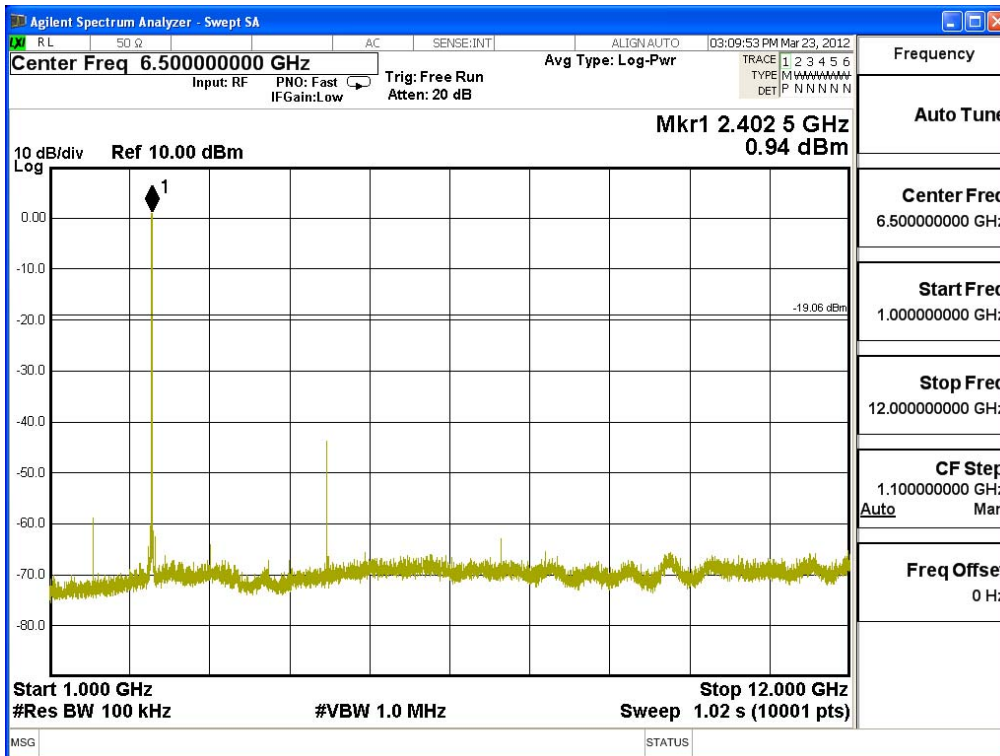

Product : Play-Fi Player  
 Test Item : RF Antenna Conducted Test  
 Test Site : No.3 OATS  
 Test Mode : Mode 2: Transmit - 3Mbps (8DPSK)

**Figure Channel 39:**

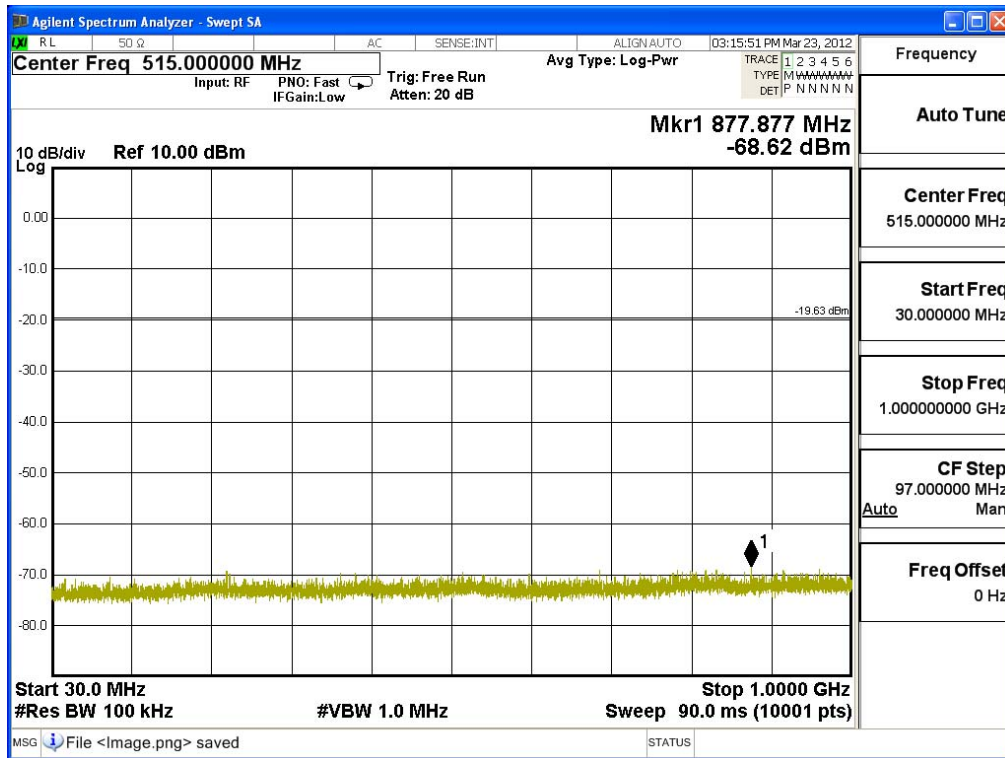

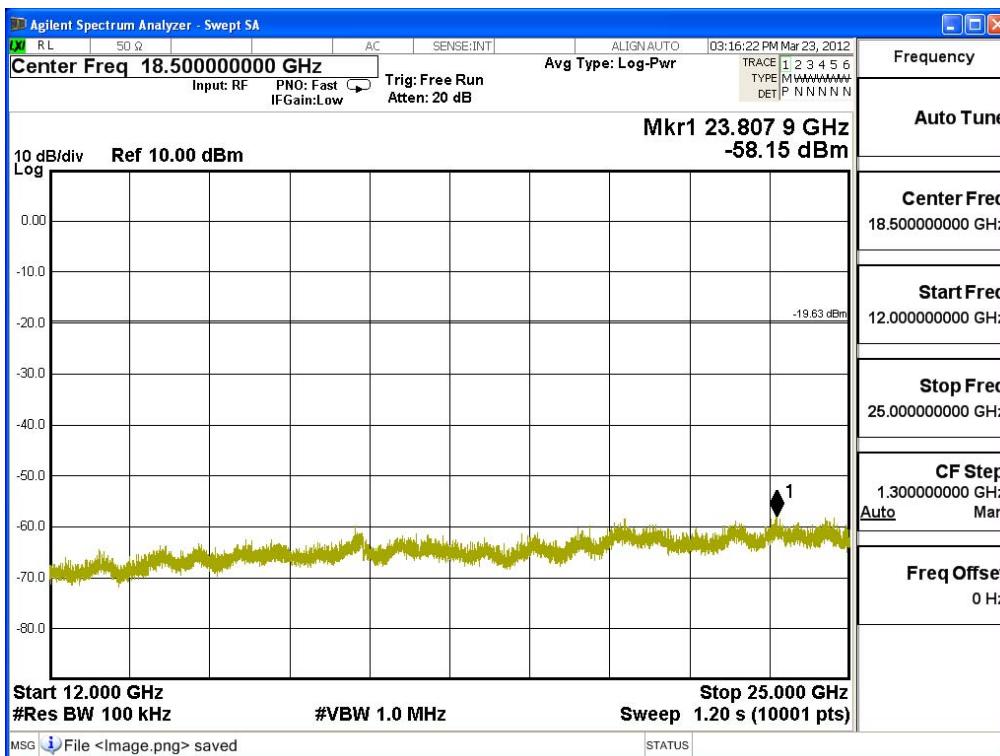
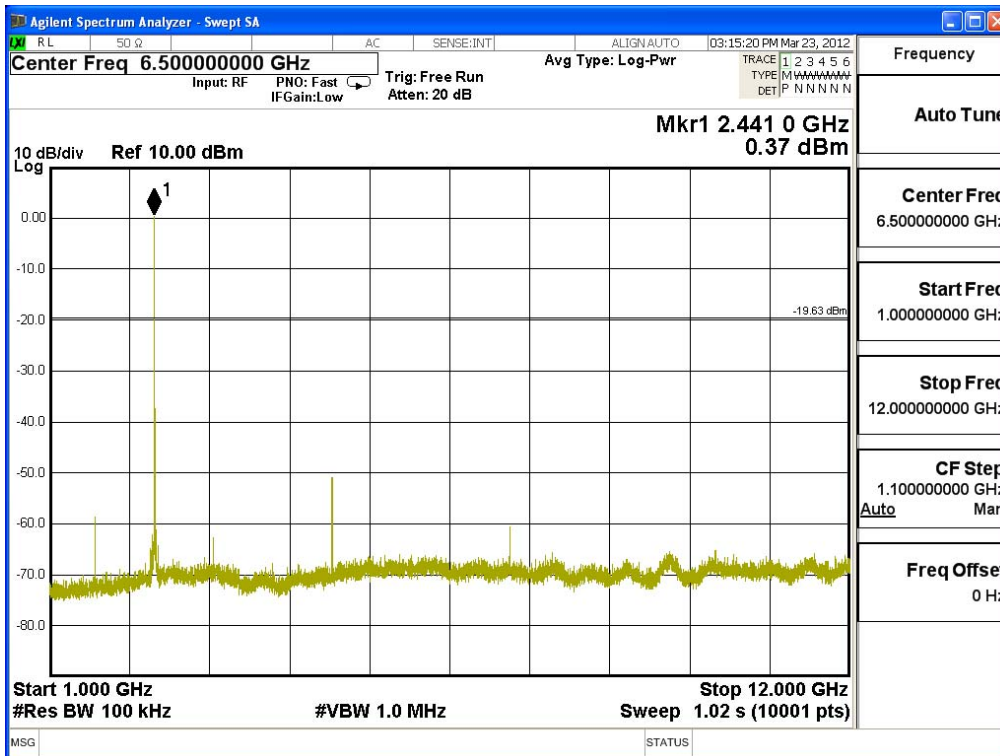

Product : Play-Fi Player  
 Test Item : RF Antenna Conducted Test  
 Test Site : No.3 OATS  
 Test Mode : Mode 2: Transmit - 3Mbps (8DPSK)

**Figure Channel 78:**

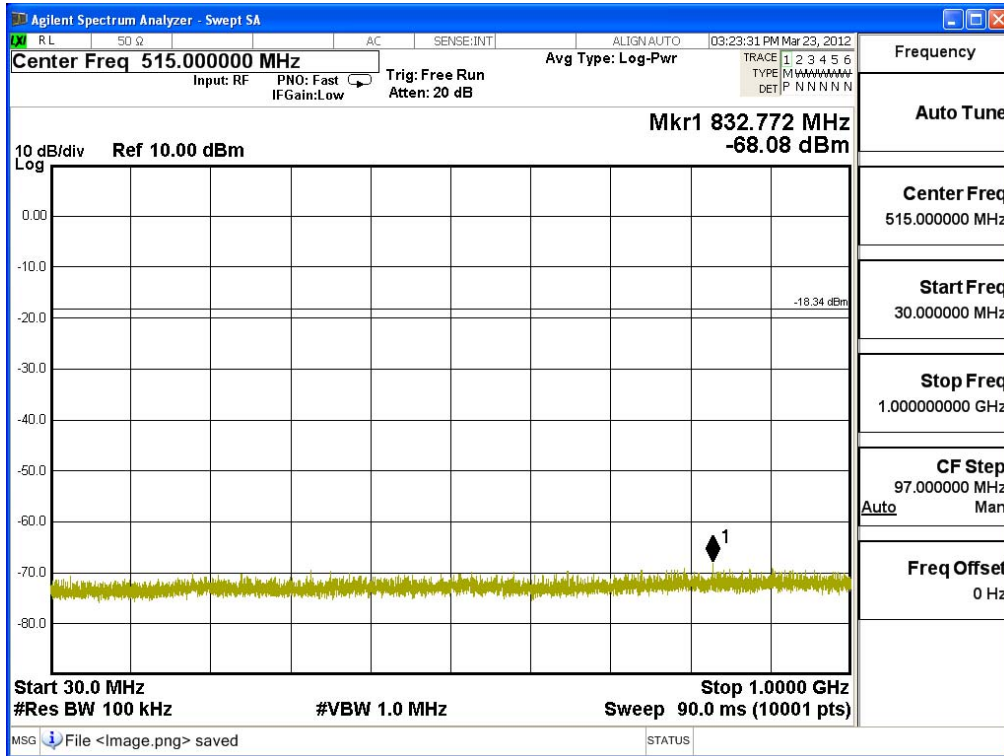

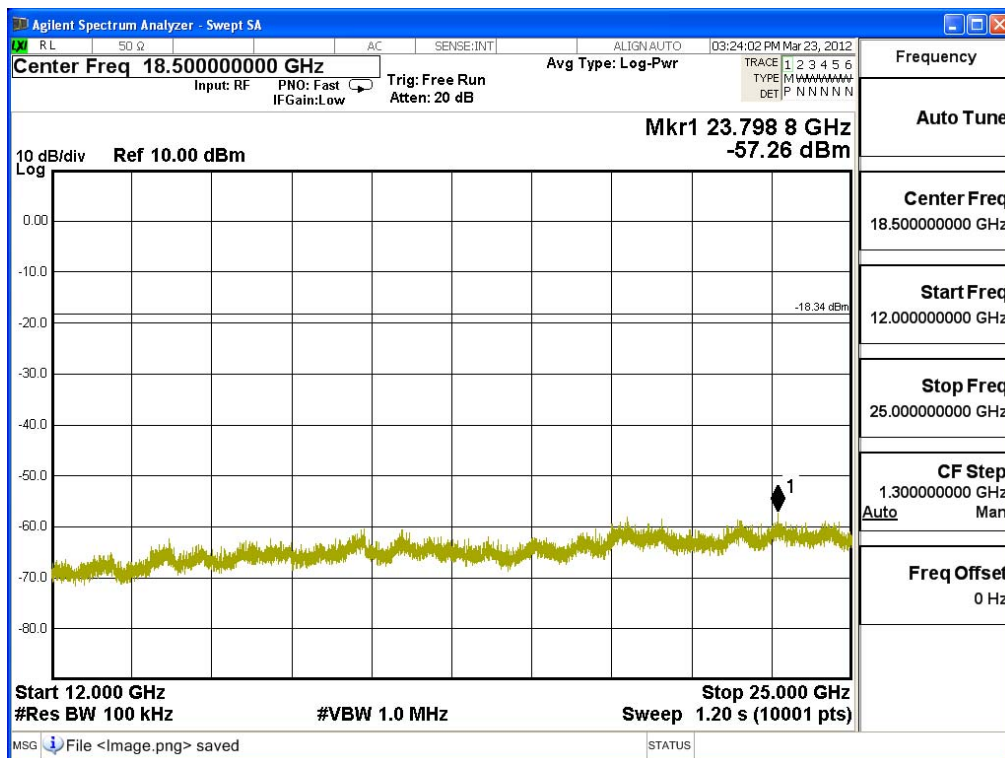
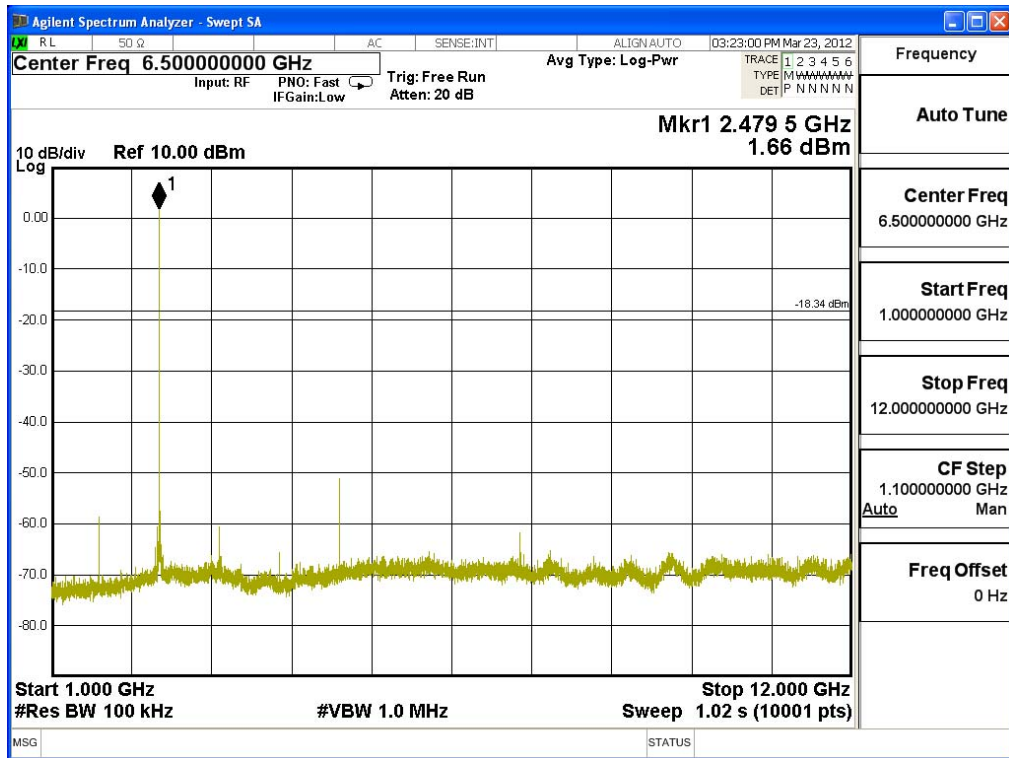



## 6. Band Edge

### 6.1. Test Equipment

#### RF Conducted Measurement

The following test equipments are used during the band edge tests:

|   | Equipment         | Manufacturer | Model No./Serial No. | Last Cal.  |
|---|-------------------|--------------|----------------------|------------|
|   | Spectrum Analyzer | R&S          | FSP40 / 100170       | Jun, 2011  |
|   | Spectrum Analyzer | Agilent      | E4407B / US39440758  | Jun, 2011  |
| X | Spectrum Analyzer | Agilent      | N9010A / MY48030495  | Apr., 2012 |

#### RF Radiated Measurement:

The following test equipments are used during the band edge tests:

| Test Site  |   | Equipment         | Manufacturer    | Model No./Serial No.  | Last Cal.  |
|------------|---|-------------------|-----------------|-----------------------|------------|
| ☒ Site # 3 |   | Bilog Antenna     | Schaffner Chase | CBL6112B/2673         | Sep., 2011 |
|            | X | Horn Antenna      | Schwarzbeck     | BBHA9120D/D305        | Sep., 2011 |
|            |   | Horn Antenna      | Schwarzbeck     | BBHA9170/208          | Jul., 2011 |
|            | X | Pre-Amplifier     | Agilent         | 8447D/2944A09549      | Sep., 2011 |
|            | X | Spectrum Analyzer | Agilent         | E4407B / US39440758   | May, 2011  |
|            |   | Test Receiver     | R & S           | ESCS 30/ 825442/018   | Sep., 2011 |
|            | X | Coaxial Cable     | Quietek         | QTK-CABLE/ CAB5       | Feb., 2012 |
|            | X | Controller        | Quietek         | QTK-CONTROLLER/ CTRL3 | N/A        |
|            | X | Coaxial Switch    | Anritsu         | MP59B/6200265729      | N/A        |

- Note:
1. All equipments are calibrated every one year.
  2. The test instruments marked by "X" are used to measure the final test results.

## 6.2. Test Setup

### RF Conducted Measurement

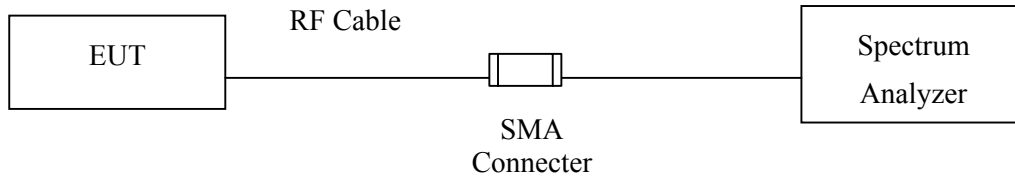

### RF Radiated Measurement:

Above 1GHz

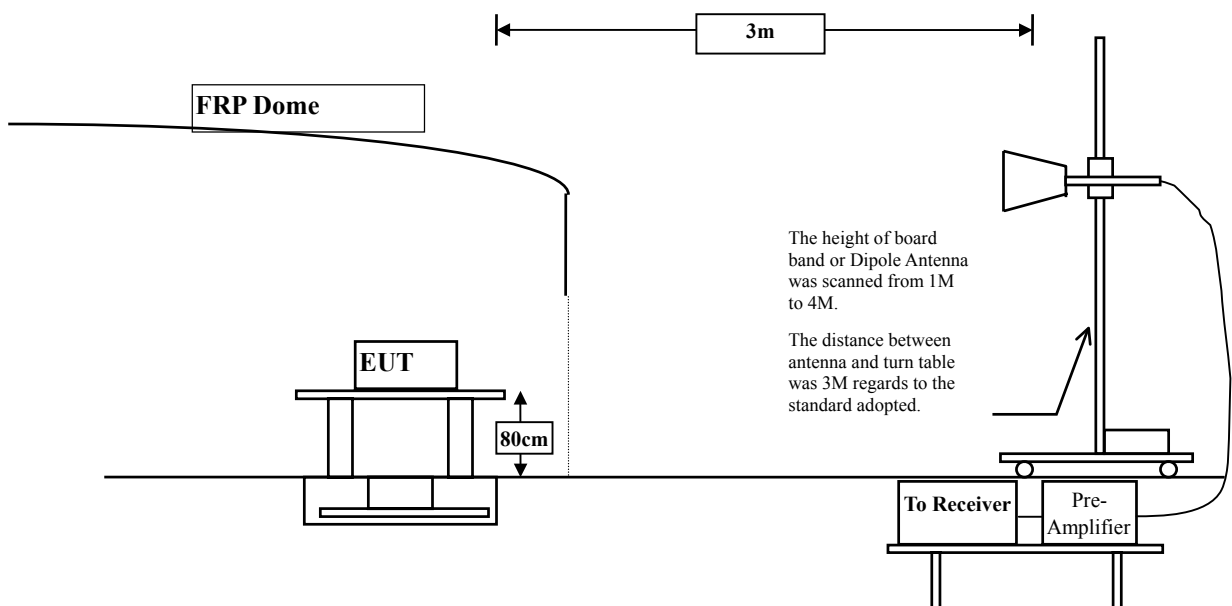

### 6.3. Limit

In any 100 kHz bandwidth outside the frequency band in which the spread spectrum intentional radiator is operating, the radio frequency power that is produced by the intentional radiator shall be at least 20 dB below that in the 100 kHz bandwidth within the band that contains the highest level of the desired power, based on either an RF conducted or a radiated measurement. Attenuation below the general limits specified in Section 15.209(a) is not required. In addition, radiated emissions which fall in the restricted bands, as defined in Section 15.205(a), must also comply with the radiated emission limits specified in Section 15.209(a) (see Section 15.205(c)).

### 6.4. Test Procedure

The EUT and its simulators are placed on a turn table which is 0.8 meter above ground. The turn table can rotate 360 degrees to determine the position of the maximum emission level. The EUT was positioned such that the distance from antenna to the EUT was 3 meters.

The antenna can move up and down between 1 meter and 4 meters to find out the maximum emission level.

Both horizontal and vertical polarization of the antenna are set on measurement. In order to find the maximum emission, all of the interface cables must be manipulated according to ANSI C63.4:2003 on radiated measurement.

The bandwidth below 1GHz setting on the field strength meter is 120 kHz, above 1GHz are 1 MHz. The EUT was setup to ANSI C63.4, 2003; tested to FHSS test procedure of FCC Public Notice DA 00-705 for compliance to FCC 47CFR 15.247 requirements.

### 6.5. Uncertainty

± 3.9 dB above 1GHz

± 3.8 dB below 1GHz

## 6.6. Test Result of Band Edge

Product : Play-Fi Player  
 Test Item : Band Edge  
 Test Site : No.3 OATS  
 Test Mode : Mode 1: Transmit - 1Mbps (GFSK)

### Fundamental Filed Strength

| Antenna Pole | Frequency [MHz] | Correction Factor [dB/m] | Reading Level [dBuV] | Emission Level [dBuV/m] | Detector |
|--------------|-----------------|--------------------------|----------------------|-------------------------|----------|
| Horizontal   | 2402            | 31.573                   | 60.53                | 92.104                  | Peak     |
| Horizontal   | 2402            | 31.573                   | 49.714               | 81.288                  | Average  |
| Vertical     | 2402            | 30.917                   | 65.792               | 96.709                  | Peak     |
| Vertical     | 2402            | 30.917                   | 53.968               | 84.885                  | Average  |

Note: 1:Spectrum Analyzer setting:

Peak detector: RBW=1MHz, VBW=1MHz

Average detector: RBW=1MHz, VBW=10Hz

### Band Edge Test Data

| Antenna Pole | Test Frequency (MHz) | Fundamental (dBuV/m) | $\Delta$ (dB) | Band Edge Field Strength (dBuV/m) | Limit (dBuV/m) | Detector |
|--------------|----------------------|----------------------|---------------|-----------------------------------|----------------|----------|
| Horizontal   | 2375.9               | 92.104               | 58.49         | 33.614                            | 74.000         | Peak     |
| Horizontal   | 2376                 | 81.288               | 52.12         | 29.168                            | 54.000         | Average  |
| Vertical     | 2375.9               | 96.709               | 58.49         | 38.219                            | 74.000         | Peak     |
| Vertical     | 2376                 | 84.885               | 52.12         | 32.765                            | 54.000         | Average  |

Note:

The Band Edge Field Strength was calculated using the Fundamental and Conducted Band Edge measurements per the Marker-Delta Method with the following formula:

Band Edge field Strength = F -  $\Delta$

F = Fundamental field Strength (Peak or Average)

$\Delta$  = Conducted Band Edge Delta (Peak or Average)

### Peak Detector of conducted Band Edge Delta

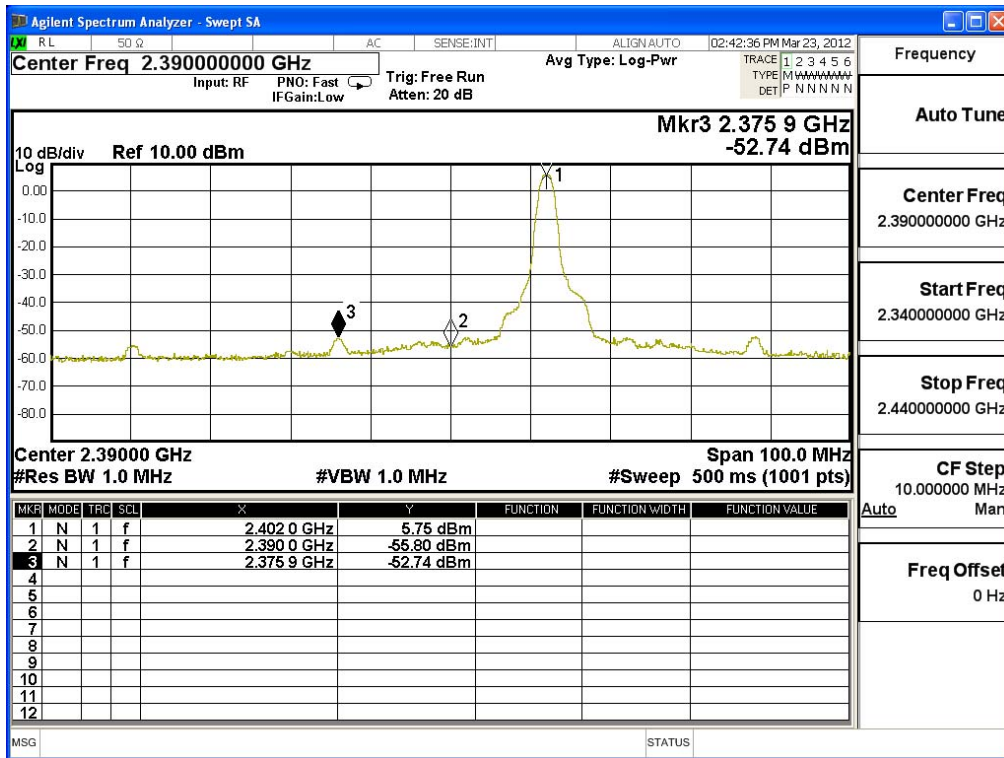

### Average Detector of conducted Band Edge Delta

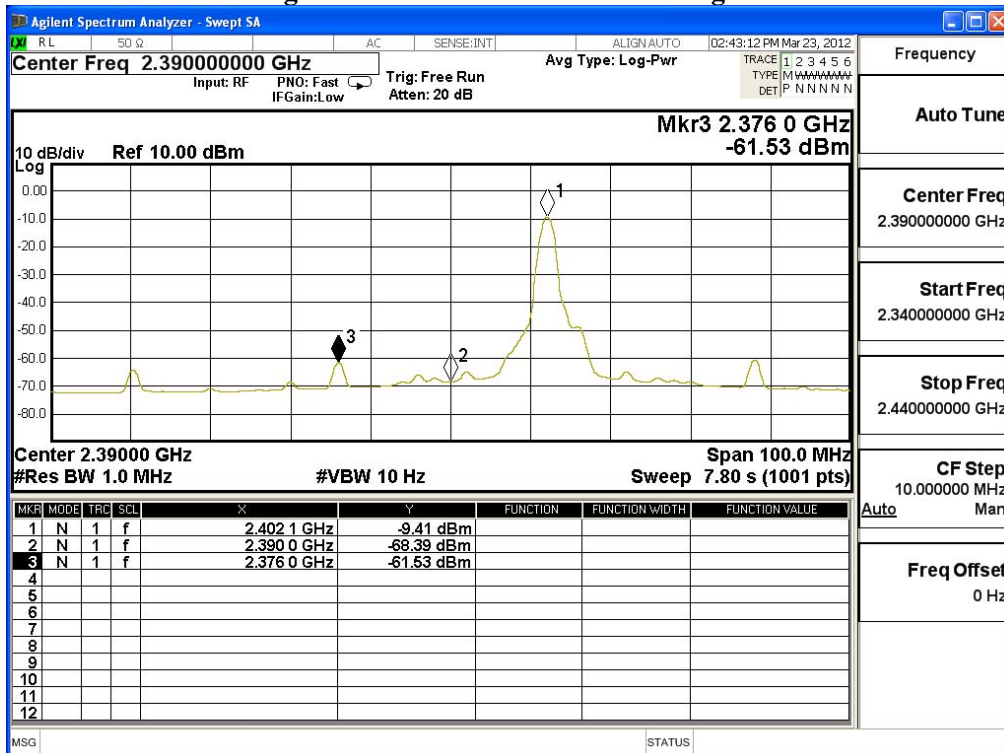

Product : Play-Fi Player  
 Test Item : Band Edge  
 Test Site : No.3 OATS  
 Test Mode : Mode 1: Transmit - 1Mbps (GFSK)

### Fundamental Filed Strength

| Antenna Pole | Frequency [MHz] | Correction Factor [dB/m] | Reading Level [dBuV] | Emission Level [dB(uV/m)] | Detector |
|--------------|-----------------|--------------------------|----------------------|---------------------------|----------|
| Horizontal   | 2480            | 32.155                   | 57.209               | 89.365                    | Peak     |
| Horizontal   | 2480            | 32.155                   | 46.861               | 79.017                    | Average  |
| Vertical     | 2480            | 31.412                   | 64.021               | 95.433                    | Peak     |
| Vertical     | 2480            | 31.412                   | 52.637               | 84.049                    | Average  |

Note: 1:Spectrum Analyzer setting:

Peak detector: RBW=1MHz, VBW=1MHz

Average detector: RBW=1MHz, VBW=10Hz

### Band Edge Test Data

| Antenna Pole | Test Frequency (MHz) | Fundamental (dBuV/m) | $\Delta$ (dB) | Band Edge Field Strength (dBuV/m) | Limit (dBuV/m) | Detector |
|--------------|----------------------|----------------------|---------------|-----------------------------------|----------------|----------|
| Horizontal   | 2483.5               | 89.365               | 50.5          | 38.865                            | 74.000         | Peak     |
| Horizontal   | 2483.5               | 79.017               | 49.78         | 29.237                            | 54.000         | Average  |
| Vertical     | 2483.5               | 95.433               | 50.5          | 44.933                            | 74.000         | Peak     |
| Vertical     | 2483.5               | 84.049               | 49.78         | 34.269                            | 54.000         | Average  |

Note:

The Band Edge Field Strength was calculated using the Fundamental and Conducted Band Edge measurements per the Marker-Delta Method with the following formula:

Band Edge field Strength =  $F - \Delta$

F = Fundamental field Strength (Peak or Average)

$\Delta$  = Conducted Band Edge Delta (Peak or Average)

### Peak Detector of conducted Band Edge Delta

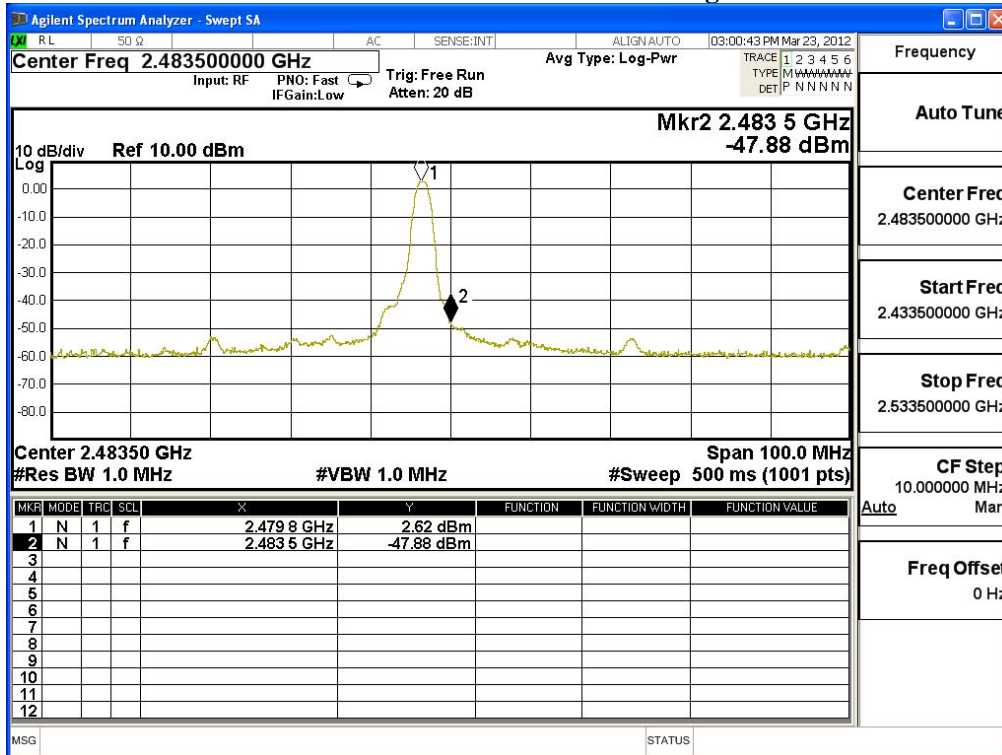

### Average Detector of conducted Band Edge Delta

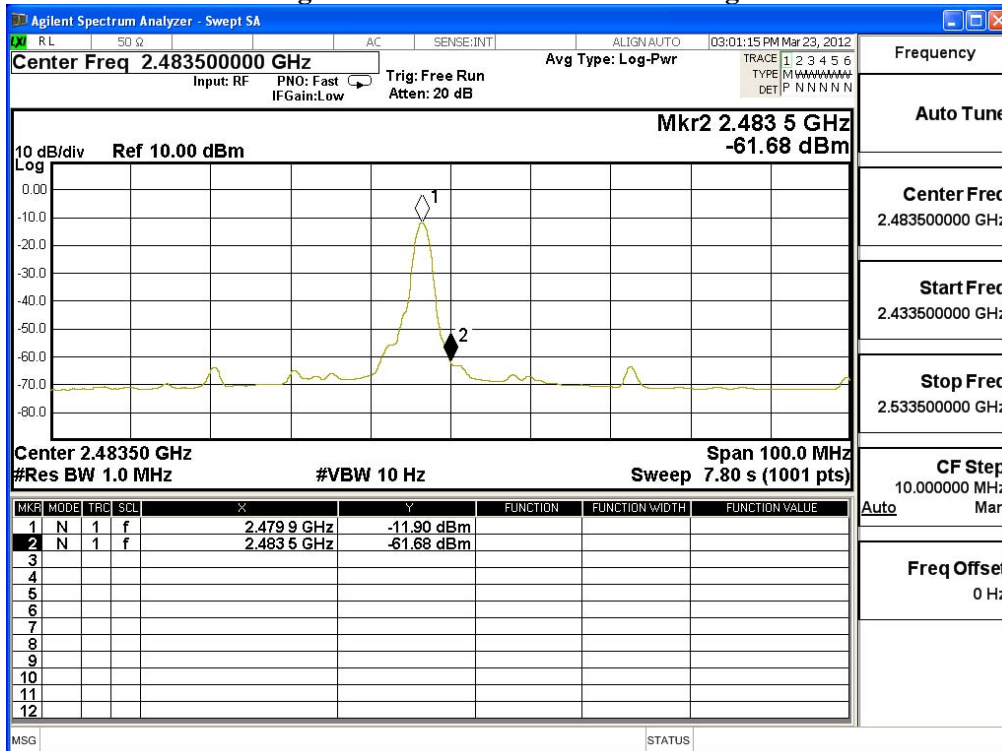

Product : Play-Fi Player  
 Test Item : Band Edge  
 Test Site : No.3 OATS  
 Test Mode : Mode 2: Transmit - 3Mbps (8DPSK)

### Fundamental Filed Strength

| Antenna Pole | Frequency [MHz] | Correction Factor [dB/m] | Reading Level [dBuV] | Emission Level [dBuV/m] | Detector |
|--------------|-----------------|--------------------------|----------------------|-------------------------|----------|
| Horizontal   | 2402            | 31.573                   | 58.941               | 90.515                  | Peak     |
| Horizontal   | 2402            | 31.573                   | 46.322               | 77.896                  | Average  |
| Vertical     | 2402            | 30.917                   | 64.378               | 95.295                  | Peak     |
| Vertical     | 2402            | 30.917                   | 50.998               | 81.915                  | Average  |

Note: 1:Spectrum Analyzer setting:

Peak detector: RBW=1MHz, VBW=1MHz

Average detector: RBW=1MHz, VBW=10Hz

### Band Edge Test Data

| Antenna Pole | Test Frequency (MHz) | Fundamental (dBuV/m) | $\Delta$ (dB) | Band Edge Field Strength (dBuV/m) | Limit (dBuV/m) | Detector |
|--------------|----------------------|----------------------|---------------|-----------------------------------|----------------|----------|
| Horizontal   | 2388                 | 90.515               | 57.69         | 32.825                            | 74.000         | Peak     |
| Horizontal   | 2376                 | 77.896               | 51.74         | 26.156                            | 54.000         | Average  |
| Vertical     | 2388                 | 95.295               | 57.69         | 37.605                            | 74.000         | Peak     |
| Vertical     | 2376                 | 81.915               | 51.74         | 30.175                            | 54.000         | Average  |

Note:

The Band Edge Field Strength was calculated using the Fundamental and Conducted Band Edge measurements per the Marker-Delta Method with the following formula:

Band Edge field Strength = F -  $\Delta$

F = Fundamental field Strength (Peak or Average)

$\Delta$  = Conducted Band Edge Delta (Peak or Average)



### Peak Detector of conducted Band Edge Delta

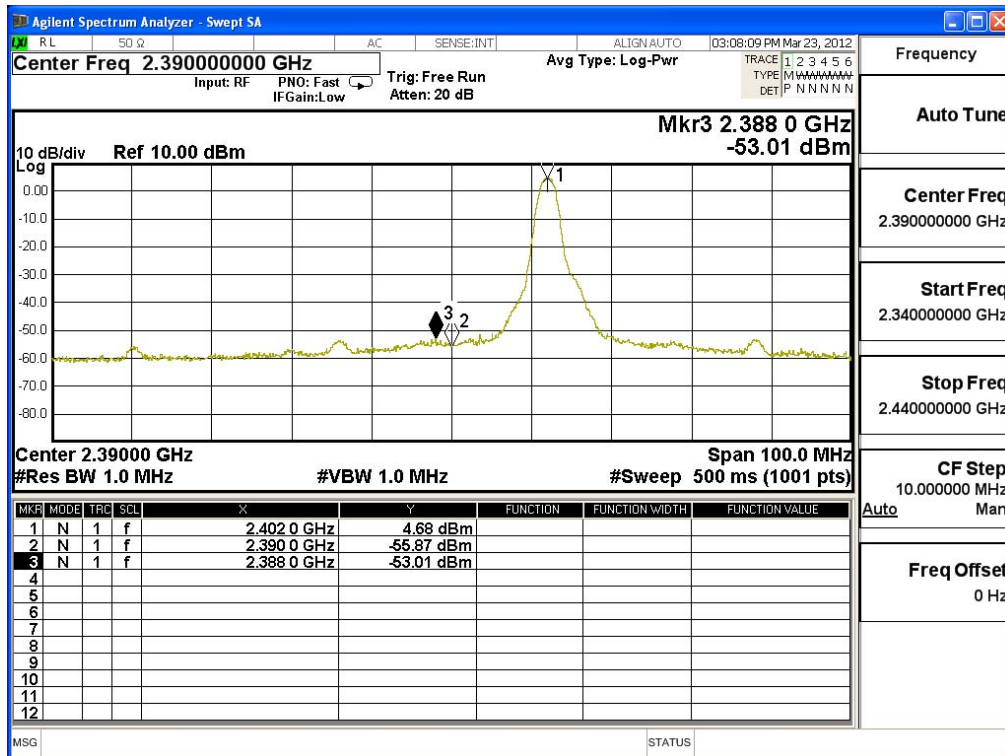

### Average Detector of conducted Band Edge Delta

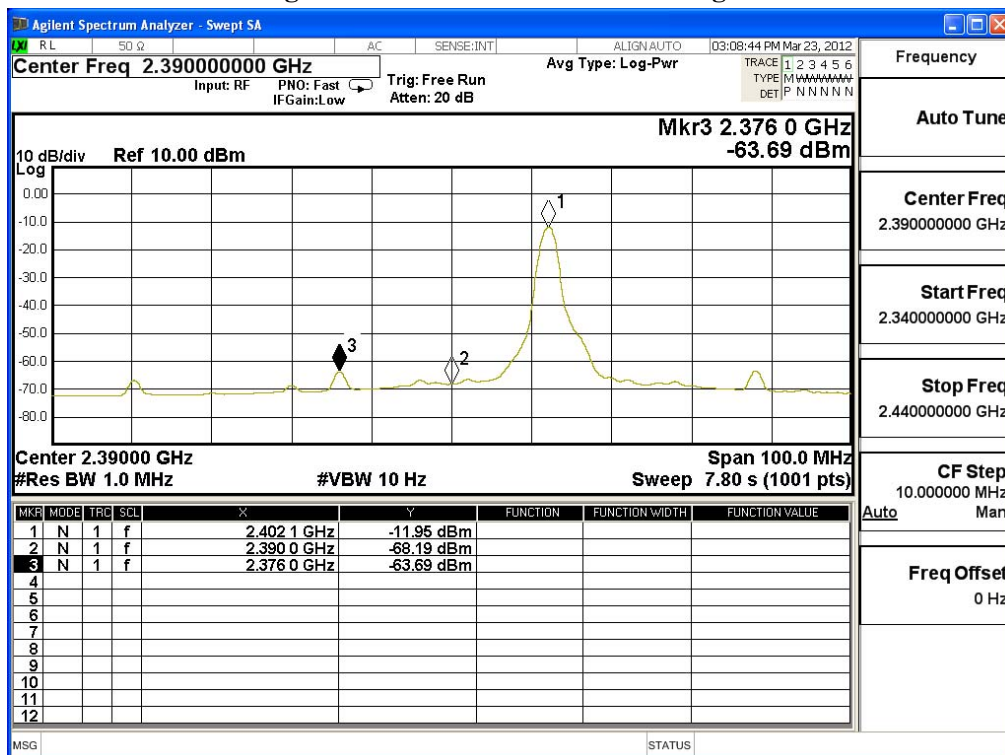

Product : Play-Fi Player  
 Test Item : Band Edge  
 Test Site : No.3 OATS  
 Test Mode : Mode 2: Transmit - 3Mbps (8DPSK)

### Fundamental Filed Strength

| Antenna Pole | Frequency [MHz] | Correction Factor [dB/m] | Reading Level [dBuV] | Emission Level [dB(uV/m)] | Detector |
|--------------|-----------------|--------------------------|----------------------|---------------------------|----------|
| Horizontal   | 2480            | 32.155                   | 56.005               | 88.161                    | Peak     |
| Horizontal   | 2480            | 32.155                   | 44.207               | 76.363                    | Average  |
| Vertical     | 2480            | 31.412                   | 63.058               | 94.47                     | Peak     |
| Vertical     | 2480            | 31.412                   | 49.908               | 81.32                     | Average  |

Note: 1:Spectrum Analyzer setting:

Peak detector: RBW=1MHz, VBW=1MHz

Average detector: RBW=1MHz, VBW=10Hz

### Band Edge Test Data

| Antenna Pole | Test Frequency (MHz) | Fundamental (dBuV/m) | $\Delta$ (dB) | Band Edge Field Strength (dBuV/m) | Limit (dBuV/m) | Detector |
|--------------|----------------------|----------------------|---------------|-----------------------------------|----------------|----------|
| Horizontal   | 2483.6               | 88.161               | 48.87         | 39.291                            | 74.000         | Peak     |
| Horizontal   | 2483.5               | 76.363               | 46.44         | 29.923                            | 54.000         | Average  |
| Vertical     | 2483.6               | 94.47                | 48.87         | 45.6                              | 74.000         | Peak     |
| Vertical     | 2483.5               | 81.32                | 46.44         | 34.88                             | 54.000         | Average  |

Note:

The Band Edge Field Strength was calculated using the Fundamental and Conducted Band Edge measurements per the Marker-Delta Method with the following formula:

Band Edge field Strength = F -  $\Delta$

F = Fundamental field Strength (Peak or Average)

$\Delta$  = Conducted Band Edge Delta (Peak or Average)

### Peak Detector of conducted Band Edge Delta

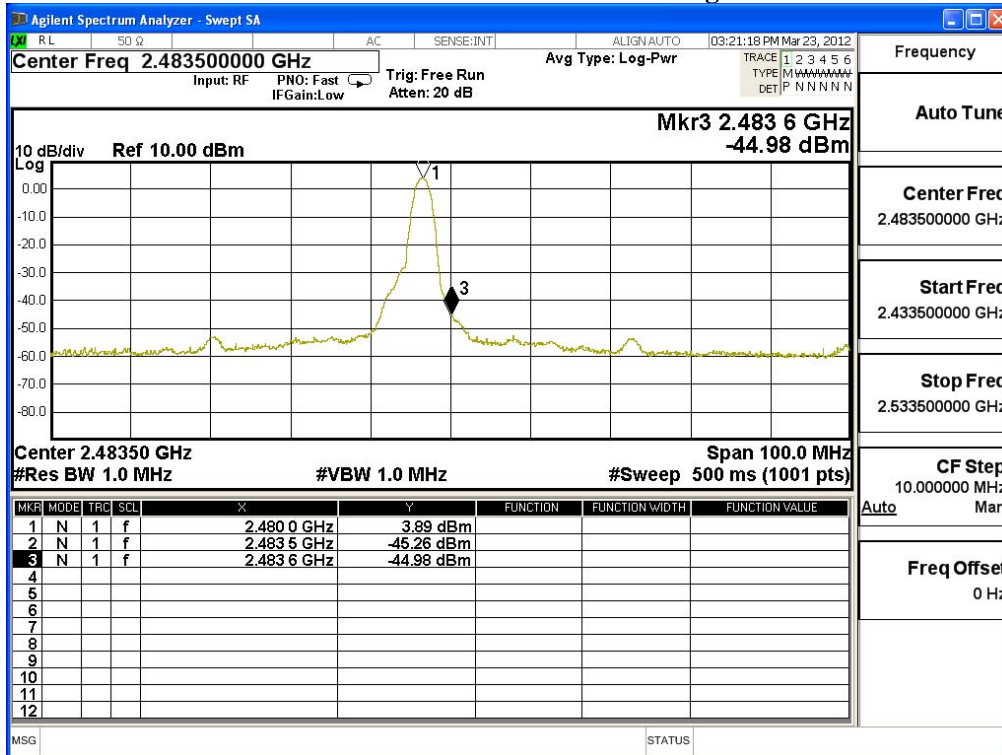

### Average Detector of conducted Band Edge Delta

