



# Test Report

**Compliance with Industry Canada Interference-Causing  
Equipment Standard ICES-003**

Product Name : HP Smart Wi-Fi Display

Model No. : DP-803AH(Sd828)

Applicant : Lite-On Technology Corp.

Address : 4F, 90, Chien 1 Road, Chung-Ho, Taipei Hsien 235,  
Taiwan, R.O.C.

Date of Receipt : 2009/06/22

Issued Date : 2009/07/20

Report No. : 096335R-ITUSP02V02

Report Version : V1.0

The test results relate only to the samples tested.

The test results shown in the test report are traceable to the national/international standard through the calibration of the equipment and evaluated measurement uncertainty herein.

This report must not be used to claim product endorsement by TAF, NVLAP, NIST or any agency of the Government.  
The test report shall not be reproduced except in full without the written approval of QuieTek Corporation.

# Test Report Certification

Issued Date : 2009/07/20  
 Report No. : 096335R-ITUSP02V02



Product Name : HP Smart Wi-Fi Display  
 Applicant : Lite-On Technology Corp.  
 Address : 4F, 90, Chien 1 Road, Chung-Ho, Taipei Hsien 235,  
 Taiwan, R.O.C.  
 Manufacturer : DONG GUAN G-COM COMPUTER CO., LTD.  
 Model No. : DP-803AH(Sd828)  
 Rated Voltage : AC 120 V / 60 Hz  
 EUT Voltage : AC 100-240 V / 50-60 Hz  
 Trade Name : HP  
 Applicable Standard : FCC CFR Title 47 Part 15 Subpart B: 2008 Class B  
 CISPR 22: 2005, ANSI C63.4: 2003  
 ICES-003 Issue 4: 2004 Class B  
 Test Result : Complied  
 Performed Location : Quietek Corporation (Linkou Laboratory)  
 No.5-22, Ruei-Shu Valley, Ruei-Ping Tsuen Lin Kuo  
 Shiang, Taipei, 244 Taiwan, R.O.C.  
 TEL:+866-2-8601-3788 / FAX:+886-2-8601-3789

Documented By : Jinn Chen  
 ( Adm. Specialist / Jinn Chen )  
 Reviewed By : Kent Yao  
 ( Engineer / Kent Yao )  
 Approved By : [Signature]  
 ( Manager / Vincent Lin )

## Laboratory Information

We , **Quietek Corporation**, are an independent EMC and safety consultancy that was established the whole facility in our laboratories. The test facility has been accredited/accepted (audited or listed) by the following related bodies in compliance with ISO 17025, EN 45001 and specified testing scopes:

|                      |                         |
|----------------------|-------------------------|
| <b>Taiwan R.O.C.</b> | <b>: BSMI, NCC, TAF</b> |
| <b>Germany</b>       | <b>: TUV Rheinland</b>  |
| <b>Norway</b>        | <b>: Nemko, DNV</b>     |
| <b>USA</b>           | <b>: FCC, NVLAP</b>     |
| <b>Japan</b>         | <b>: VCCI</b>           |

The related certificate for our laboratories about the test site and management system can be downloaded from Quietek Corporation's Web Site : <http://tw.quietek.com/modules/enterprise/services.php?item=100>  
 The address and introduction of Quietek Corporation's laboratories can be founded in our Web site : <http://www.quietek.com/>

If you have any comments, Please don't hesitate to contact us. Our contact information is as below:

### HsinChu Testing Laboratory :

No.75-2, 3rd Lin, Wangye Keng, Yonghxing Tsuen, Qionglin Shiang, Hsinchu County 307, Taiwan, R.O.C.

TEL:+886-3-592-8858 / FAX:+886-3-592-8859

E-Mail : [service@quietek.com](mailto:service@quietek.com)



### LinKou Testing Laboratory :

No. 5, Ruei-Shu Valley, Ruei-Ping Tsuen, Lin-Kou Shiang, Taipei, Taiwan, R.O.C.

TEL : 886-2-8601-3788 / FAX : 886-2-8601-3789

E-Mail : [service@quietek.com](mailto:service@quietek.com)



### Suzhou (China) Testing Laboratory :

No. 99 Hongye Rd., Suzhou Industrial Park Loufeng Hi-Tech Development Zone., Suzhou,China.

TEL : +86-512-6251-5088 / FAX : +86-512-6251-5098

E-Mail : [service@quietek.com](mailto:service@quietek.com)



## TABLE OF CONTENTS

| Description                               | Page |
|---|------|
| 1. General Information .....              | 5    |
| 1.1. EUT Description.....                 | 5    |
| 1.2. Mode of Operation .....              | 6    |
| 1.3. Tested System Details .....          | 7    |
| 1.4. Configuration of Tested System ..... | 8    |
| 1.5. EUT Exercise Software.....           | 10   |
| 2. Technical Test .....                   | 11   |
| 2.1. Summary of Test Result.....          | 11   |
| 2.2. List of Test Equipment .....         | 12   |
| 2.3. Measurement Uncertainty.....         | 13   |
| 2.4. Test Environment.....                | 14   |
| 3. Conducted Emission .....               | 15   |
| 3.1. Test Specification .....             | 15   |
| 3.2. Test Setup.....                      | 15   |
| 3.3. Limit.....                           | 15   |
| 3.4. Test Procedure .....                 | 16   |
| 3.5. Test Result .....                    | 17   |
| 3.6. Test Photograph .....                | 35   |
| 4. Radiated Emission.....                 | 38   |
| 4.1. Test Specification .....             | 38   |
| 4.2. Test Setup.....                      | 38   |
| 4.3. Limit.....                           | 39   |
| 4.4. Test Procedure .....                 | 40   |
| 4.5. Test Result .....                    | 41   |
| 4.6. Test Photograph .....                | 55   |
| 5. Attachment.....                        | 61   |
| EUT Photograph.....                       | 61   |

## 1. General Information

### 1.1. EUT Description

|              |                        |
|--------------|------------------------|
| Product Name | HP Smart Wi-Fi Display |
| Trade Name   | HP                     |
| Model No.    | DP-803AH(Sd828)        |

| Component         |  |
|-------------------|--|
| Earphone Cable    | Non-shielded, 1.4m   |
| USB Cable         | Shielded, 1.0m   |
| Power Adapter (1) | MFR: DVE, M/N: DSA-15P-12 US 120144<br>Input: AC 100-240V / 50-60Hz<br>Output: DC 12V, 1.2A<br>Cable Out: Non-shielded, 1.5m |
| Power Adapter (2) | MFR: Powertron, M/N: PA1015-2HU<br>Input: AC 100-240V / 50-60Hz<br>Output: DC 12V, 1.25A<br>Cable Out: Non-shielded, 1.5m    |

**1.2. Mode of Operation**

Quietek has verified the construction and function in typical operation. All the test modes were carried out with the EUT in normal operation, which was shown in this test report and defined as:

|  |  |
|--|--|
| Pre-Test Mode  |  |
| Mode 1: Video with Flash + WLAN Mode with DVE Adapter                    |  |
| Mode 2: MP3 with SD + WLAN Mode with DVE Adapter                         |  |
| Mode 3: Photo with CF + WLAN Mode with DVE Adapter                       |  |
| Mode 4: Video with USB + WLAN Mode with DVE Adapter                      |  |
| Mode 5: Link PC Mode   |  |
| Mode 6: Video with Flash + WLAN Mode (Without Earphone) with DVE Adapter |  |
| Mode 7: Video with Flash + WLAN Mode with Powertron Adapter              |  |
| Final Test Mode  |  |
| Conducted Emission   | Mode 1: Video with Flash + WLAN Mode with DVE Adapter<br>Mode 5: Link PC Mode<br>Mode 7: Video with Flash + WLAN Mode with Powertron Adapter   |
| Radiated Emission  | Mode 1: Video with Flash + WLAN Mode with DVE Adapter<br>Mode 5: Link PC Mode<br>Mode 6: Video with Flash + WLAN Mode (Without Earphone) with DVE Adapter<br>Mode 7: Video with Flash + WLAN Mode with Powertron Adapter |

### 1.3. Tested System Details

The types for all equipments, plus descriptions of all cables used in the tested system (including inserted cards) are:

|           |             |  |           |                   |                    |
|-----------|-------------|--|-----------|-------------------|--------------------|
| Test Mode |             | Mode 1: Video with Flash + WLAN Mode with DVE Adapter<br>Mode 7: Video with Flash + WLAN Mode with Powertron Adapter |           |                   |                    |
| Product   |             | Manufacturer   | Model No. | Serial No.        | Power Cord         |
| 1         | Notebook PC | DELL   | D630      | 00144-023-351-283 | Non-Shielded, 0.8m |

|           |                       |                      |            |                        |                    |                    |
|-----------|-----------------------|----------------------|------------|------------------------|--------------------|--------------------|
| Test Mode |                       | Mode 5: Link PC Mode |            |                        |                    |                    |
| Product   |                       | Manufacturer         | Model No.  | Serial No.             | Power Cord         |                    |
| 1         | Modem                 | ACEEX                | DM-1414    | 0102027547             | Non-Shielded, 1.8m |                    |
| 2         | Walkman               | AIWA                 | HS-TA164   | N/A                    | N/A                |                    |
| 3         | Keyboard              | COMPAQ               | KB-0133    | B55940MGAPK00M         | N/A                |                    |
| 4         | Mouse                 | HP                   | M-S69      | N/A                    | N/A                |                    |
| 5         | Microphone & Earphone | PCHOME               | N/A        | N/A                    | N/A                |                    |
| 6         | PC                    | CPU                  | INTEL      | CELERON CPU<br>2.93GHz | N/A                | Non-Shielded, 1.8m |
|           |                       | RAM                  | LONG DIMM  | DDR2-533 256M          | N/A                |                    |
|           |                       | MB                   | ASUS       | P5GD2-TVM/S            | N/A                |                    |
|           |                       | HDD                  | HITACHI    | 82.3G/7200RPM          | N/A                |                    |
|           |                       | VGA                  | ASUS       | EN6600/TD/256M<br>/A   | N/A                |                    |
|           |                       | POWER                | ASUS       | S-30FP 300W            | N/A                |                    |
|           |                       | ODD                  | ASUS       | DVD-E616A2/A5/<br>QT   | N/A                |                    |
|           |                       | FLOPPY               | N/A        | 1.44MB/2<br>MODE/BLACK | N/A                |                    |
| 7         | Microphone & Earphone | EUT                  | N/A        | N/A                    | N/A                |                    |
| 8         | Printer               | EPSON                | StyLus C63 | FAPY093590             | Non-Shielded, 1.8m |                    |
| 9         | LCD Monitor           | CMV                  | CT-730D    | FNC122F57CA1025        | Non-Shielded, 1.8m |                    |

### 1.4. Configuration of Tested System

|   |                |  |
|---|----------------|--|
| Test Mode   |                | Mode 1: Video with Flash + WLAN Mode with DVE Adapter<br>Mode 7: Video with Flash + WLAN Mode with Powertron Adapter |
| Connection Diagram  |                |  |
| <p>The diagram shows a 'Notebook PC (1)' box on the left. A dashed-line box contains two 'EUT' boxes. Cable 'A' connects the PC to the top EUT. Cable 'B' connects the top EUT to the bottom EUT.</p> |                |  |
| Signal Cable Type   |                | Signal cable Description   |
| A   | USB Cable      | Shielded, 1.0m   |
| B   | Earphone Cable | Non-shielded, 1.4m   |



|           |                      |
|-----------|----------------------|
| Test Mode | Mode 5: Link PC Mode |
|-----------|----------------------|

Connection Diagram

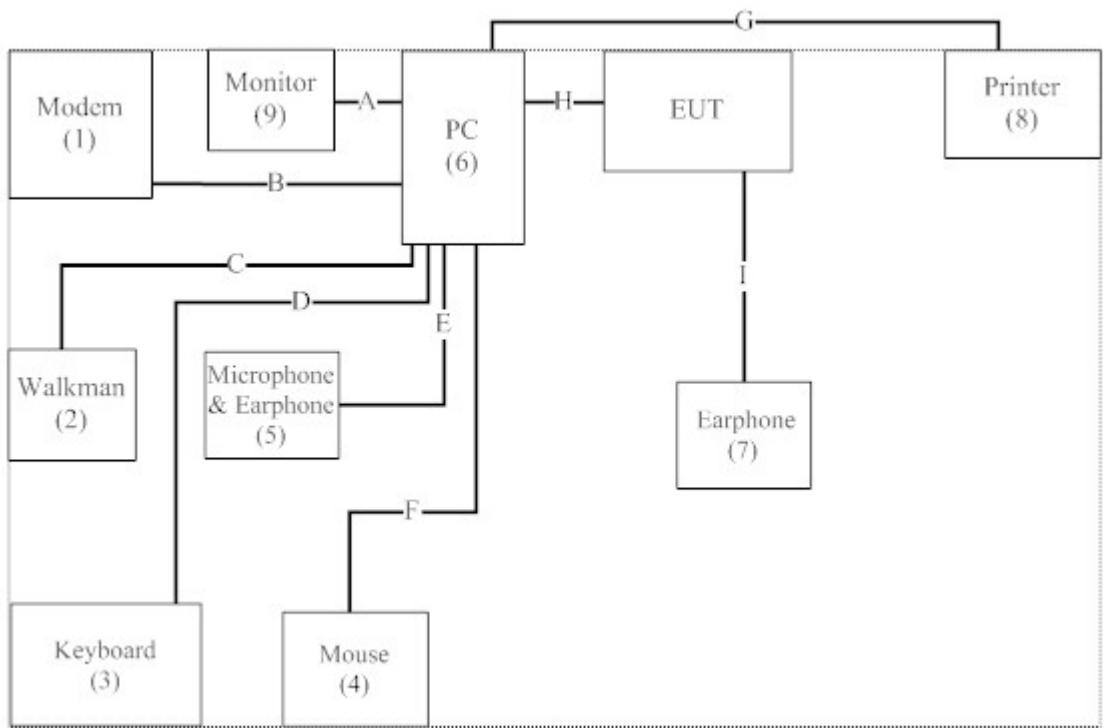

| Signal Cable Type |                             | Signal cable Description                      |
|-------------------|-----------------------------|---|
| A                 | D-SUB Cable                 | Shielded, 1.8m with two ferrite cores bonded. |
| B                 | RS232 Cable                 | Shielded, 1.5m                                |
| C                 | Audio Cable                 | Non-Shielded, 1.6m                            |
| D                 | PS/2 Keyboard Cable         | Shielded, 1.8m                                |
| E                 | Earphone & Microphone Cable | Non-Shielded, 1.6m                            |
| F                 | PS/2 Mouse                  | Shielded, 1.8m                                |
| G                 | Printer Cable               | Shielded, 1.2m                                |
| H                 | USB Cable                   | Shielded, 1m                                  |
| I                 | Earphone & Microphone Cable | Non-Shielded, 1.4m                            |

**1.5. EUT Exercise Software**

|     |  |
|-----|--|
| (1) | Setup the EUT and simulators as shown on 1.4.                                |
| (2) | Turn on the power of all equipment.  |
| (3) | A mufti meter was used to verify the model operation before the measurement. |

**2. Technical Test**

**2.1. Summary of Test Result**

- No deviations from the test standards
- Deviations from the test standards as below description:

| Emission           |  |                |           |
|--------------------|--|----------------|-----------|
| Performed Item     | Normative References   | Test Performed | Deviation |
| Conducted Emission | FCC CFR Title 47 Part 15 Subpart B: 2008<br>Class B ANSI C63.4: 2003 | Yes            | No        |
| Radiated Emission  | FCC CFR Title 47 Part 15 Subpart B: 2008<br>Class B ANSI C63.4: 2003 | Yes            | No        |

## 2.2. List of Test Equipment

### Conducted Emission / SR1

| Instrument        | Manufacturer | Type No. | Serial No    | Cal. Date  |
|-------------------|--------------|----------|--------------|------------|
| EMI Test Receiver | R&S          | ESCS 30  | 100366       | 2008/10/20 |
| LISN              | R&S          | ENV4200  | 833209/007   | 2008/08/14 |
| LISN              | R&S          | ENV216   | 100085       | 2009/02/17 |
| Pulse Limiter     | R&S          | ESH3-Z2  | 357.88.10.52 | 2008/09/09 |

### Radiated Emission / Site3

| Instrument             | Manufacturer    | Type No.                | Serial No  | Cal. Date  |
|------------------------|-----------------|-------------------------|------------|------------|
| Bilog Antenna          | Schaffner Chase | CBL6112B                | 2704       | 2008/08/04 |
| Broadband Horn Antenna | Schwarzbeck     | BBHA9170                | 208        | 2008/07/30 |
| EMI Test Receiver      | R&S             | ESCS 30                 | 838251/001 | 2009/04/15 |
| Horn Antenna           | Schwarzbeck     | BBHA9120D               | 305        | 2008/08/13 |
| Pre-Amplifier          | QTK             | N/A                     | N/A        | 2009/01/03 |
| Spectrum Analyzer      | Advantest       | R3162                   | 100803470  | 2008/11/25 |
| EMI Test Receiver      | R&S             | ESI 26                  | 838786/004 | 2008/07/22 |
| Pre-Amplifier          | MITEQ           | QMF-4D-18040<br>0-45-6P | 925974     | 2009/01/03 |

### Radiated Emission / Site6

| Instrument             | Manufacturer    | Type No.  | Serial No | Cal. Date  |
|------------------------|-----------------|-----------|-----------|------------|
| Bilog Antenna          | Schaffner Chase | CBL6112B  | 2909      | 2008/08/10 |
| Broadband Horn Antenna | Schwarzbeck     | BBHA9170  | 208       | 2008/07/25 |
| EMI Test Receiver      | R&S             | ESCS 30   | 100368    | 2008/08/22 |
| Horn Antenna           | Schwarzbeck     | BBHA9120D | 305       | 2008/08/10 |
| Pre-Amplifier          | QTK             | AP-025C   | 0506002   | N/A        |
| Spectrum Analyzer      | Advantest       | R3162     | 120300652 | 2009/06/28 |

### **2.3. Measurement Uncertainty**

#### Conducted Emission

The measurement uncertainty is evaluated as  $\pm 2.26$  dB.

#### Radiated Emission

The measurement uncertainty is evaluated as  $\pm 3.19$  dB.

**2.4. Test Environment**

| Performed Item     | Items                      | Required | Actual   |
|--------------------|----------------------------|----------|----------|
| Conducted Emission | Temperature (°C)           | 15-35    | 25       |
|                    | Humidity (%RH)             | 25-75    | 50       |
|                    | Barometric pressure (mbar) | 860-1060 | 950-1000 |
| Radiated Emission  | Temperature (°C)           | 15-35    | 25       |
|                    | Humidity (%RH)             | 25-75    | 50       |
|                    | Barometric pressure (mbar) | 860-1060 | 950-1000 |

### 3. Conducted Emission

#### 3.1. Test Specification

According to Standard : FCC Part 15 Subpart B, ANSI C63.4

#### 3.2. Test Setup

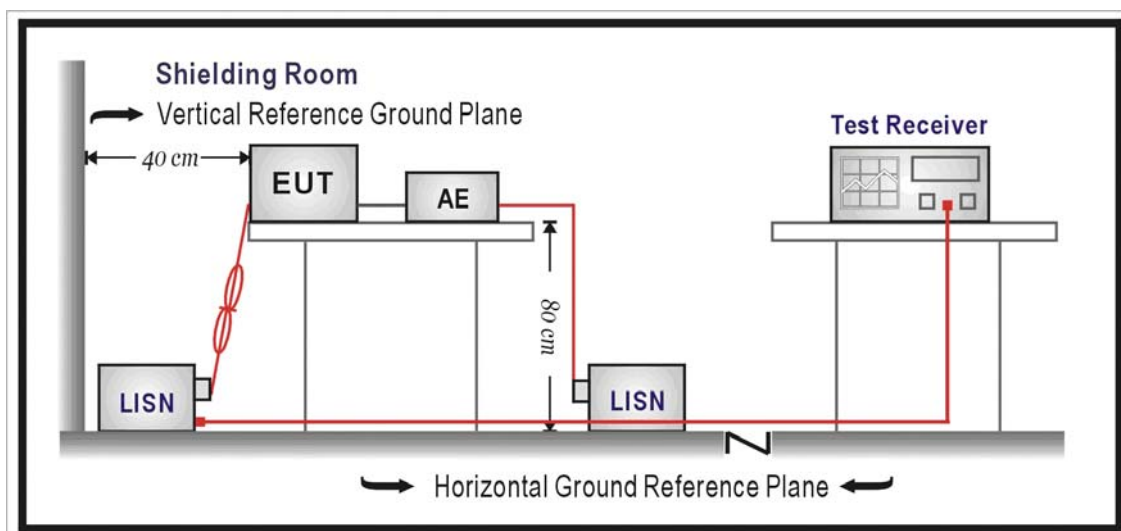

#### 3.3. Limit

| Limits          |           |           |
|-----------------|-----------|-----------|
| Frequency (MHz) | QP (dBuV) | AV (dBuV) |
| 0.15 - 0.50     | 66 - 56   | 56 - 46   |
| 0.50-5.0        | 56        | 46        |
| 5.0 - 30        | 60        | 50        |

Remarks: In the above table, the tighter limit applies at the band edges.

### 3.4. Test Procedure

The EUT and simulators are connected to the main power through a line impedance stabilization network (L.I.S.N.). This provides a 50 ohm /50uH coupling impedance for the measuring equipment. The peripheral devices are also connected to the main power through a LISN that provides a 50ohm/50uH coupling impedance with 50ohm termination.

(Please refers to the block diagram of the test setup and photographs.)

Both sides of A.C. line are checked for maximum conducted interference. In order to find the maximum emission, the relative positions of equipment and all of the interface cables must be changed on conducted measurement.

Conducted emissions were invested over the frequency range from 0.15MHz to 30MHz using a receiver bandwidth of 9kHz.



**3.5. Test Result**

|                              |                            |
|------------------------------|----------------------------|
| Site : SR1                   | Time : 2009/06/29 - 23:30  |
| Limit : CISPR_B_00M_QP       | Margin : 10                |
| EUT : HP Smart Wi-Fi Display | Probe : ENV-216-L1 - Line1 |
| Power : AC 120V/60Hz         | Note : Mode 1              |

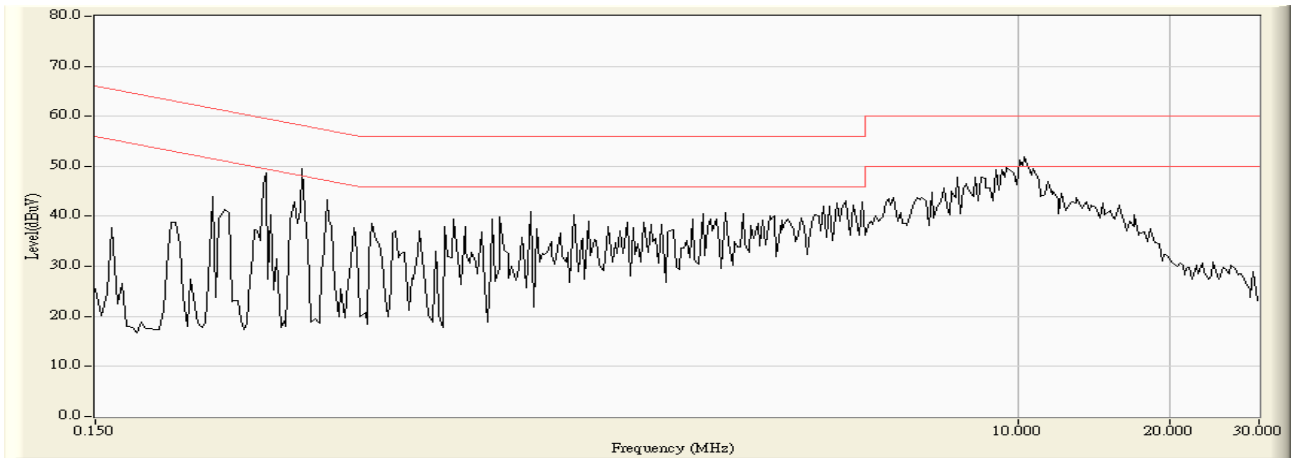

|                              |                            |
|------------------------------|----------------------------|
| Site : SR1                   | Time : 2009/06/29 - 23:30  |
| Limit : CISPR_B_00M_QP       | Margin : 0                 |
| EUT : HP Smart Wi-Fi Display | Probe : ENV-216-L1 - Line1 |
| Power : AC 120V/60Hz         | Note : Mode 1              |

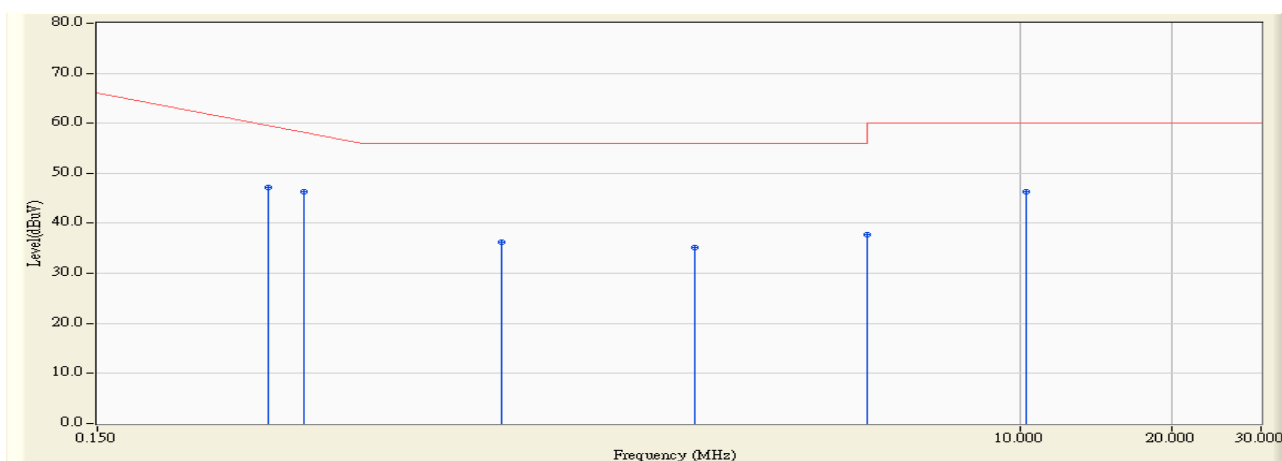

|   |   | Frequency (MHz) | Correct Factor (dB) | Reading Level (dBuV) | Measure Level (dBuV) | Margin (dB) | Limit (dBuV) | Detector Type |
|---|---|-----------------|---------------------|----------------------|----------------------|-------------|--------------|---------------|
| 1 |   | 0.326           | 9.830               | 37.440               | 47.270               | -13.701     | 60.971       | QUASPEAK      |
| 2 | * | 0.384           | 9.820               | 36.580               | 46.400               | -12.914     | 59.314       | QUASPEAK      |
| 3 |   | 0.947           | 9.830               | 26.510               | 36.340               | -19.660     | 56.000       | QUASPEAK      |
| 4 |   | 2.275           | 9.850               | 25.370               | 35.220               | -20.780     | 56.000       | QUASPEAK      |
| 5 |   | 5.002           | 9.870               | 27.830               | 37.700               | -22.300     | 60.000       | QUASPEAK      |
| 6 |   | 10.267          | 9.920               | 36.420               | 46.340               | -13.660     | 60.000       | QUASPEAK      |

**Note:**

1. All Reading Levels are Quasi-Peak and average value.
2. " \* ", means this data is the worst emission level.
3. Measurement Level = Reading Level + Correct Factor

|                              |                            |
|------------------------------|----------------------------|
| Site : SR1                   | Time : 2009/06/29 - 23:30  |
| Limit : CISPR_B_00M_AV       | Margin : 0                 |
| EUT : HP Smart Wi-Fi Display | Probe : ENV-216-L1 - Line1 |
| Power : AC 120V/60Hz         | Note : Mode 1              |

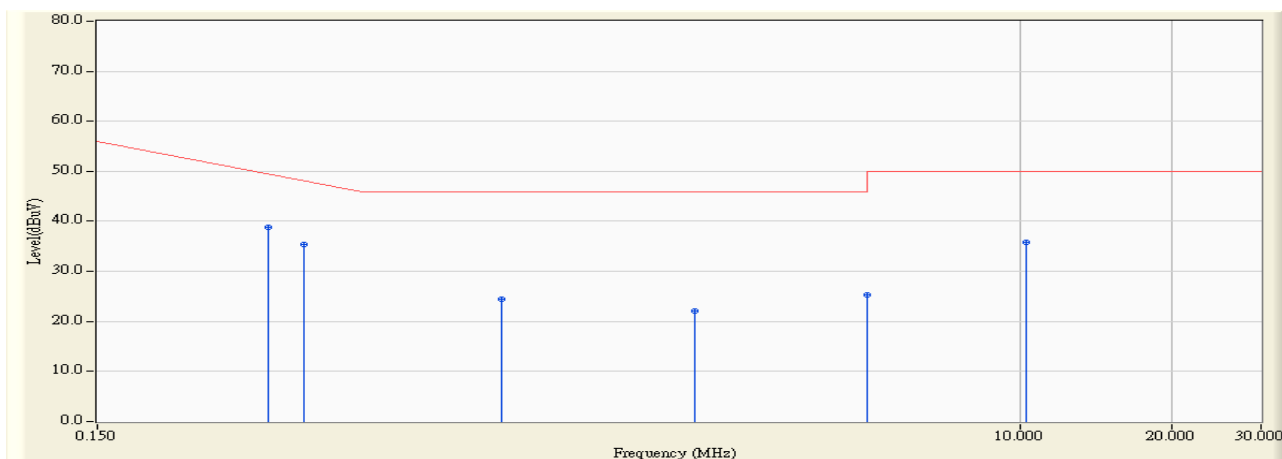

|   |   | Frequency (MHz) | Correct Factor (dB) | Reading Level (dBuV) | Measure Level (dBuV) | Margin (dB) | Limit (dBuV) | Detector Type |
|---|---|-----------------|---------------------|----------------------|----------------------|-------------|--------------|---------------|
| 1 | * | 0.326           | 9.830               | 29.060               | 38.890               | -12.081     | 50.971       | AVERAGE       |
| 2 |   | 0.384           | 9.820               | 25.640               | 35.460               | -13.854     | 49.314       | AVERAGE       |
| 3 |   | 0.947           | 9.830               | 14.700               | 24.530               | -21.470     | 46.000       | AVERAGE       |
| 4 |   | 2.275           | 9.850               | 12.190               | 22.040               | -23.960     | 46.000       | AVERAGE       |
| 5 |   | 5.002           | 9.870               | 15.400               | 25.270               | -24.730     | 50.000       | AVERAGE       |
| 6 |   | 10.267          | 9.920               | 25.900               | 35.820               | -14.180     | 50.000       | AVERAGE       |

**Note:**

1. All Reading Levels are Quasi-Peak and average value.
2. " \* ", means this data is the worst emission level.
3. Measurement Level = Reading Level + Correct Factor

|                              |                           |
|------------------------------|---------------------------|
| Site : SR1                   | Time : 2009/06/29 - 23:31 |
| Limit : CISPR_B_00M_QP       | Margin : 10               |
| EUT : HP Smart Wi-Fi Display | Probe : ENV-216-N - Line2 |
| Power : AC 120V/60Hz         | Note : Mode 1             |

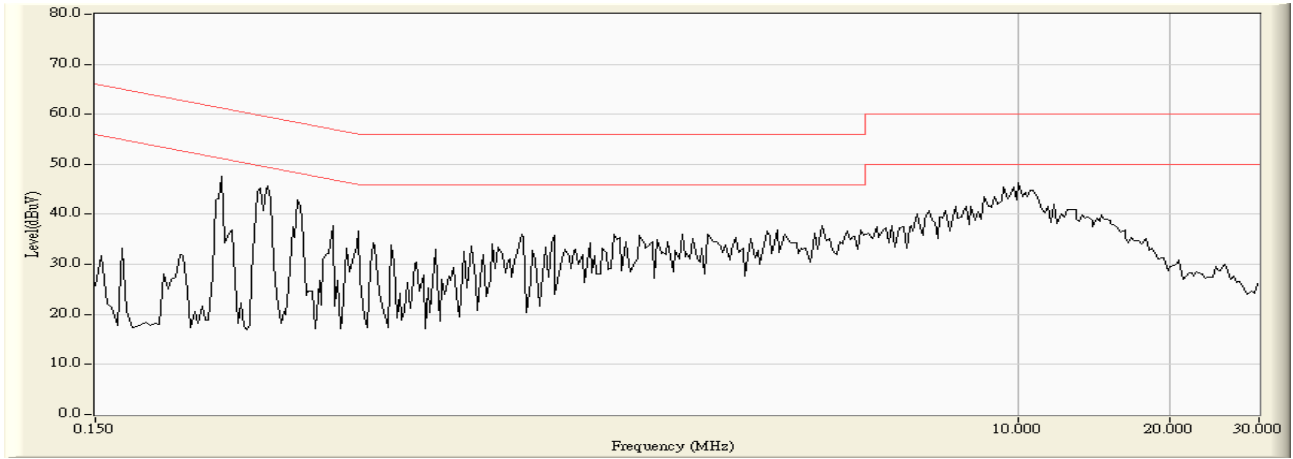

|                              |                           |
|------------------------------|---------------------------|
| Site : SR1                   | Time : 2009/06/29 - 23:32 |
| Limit : CISPR_B_00M_QP       | Margin : 0                |
| EUT : HP Smart Wi-Fi Display | Probe : ENV-216-N - Line2 |
| Power : AC 120V/60Hz         | Note : Mode 1             |

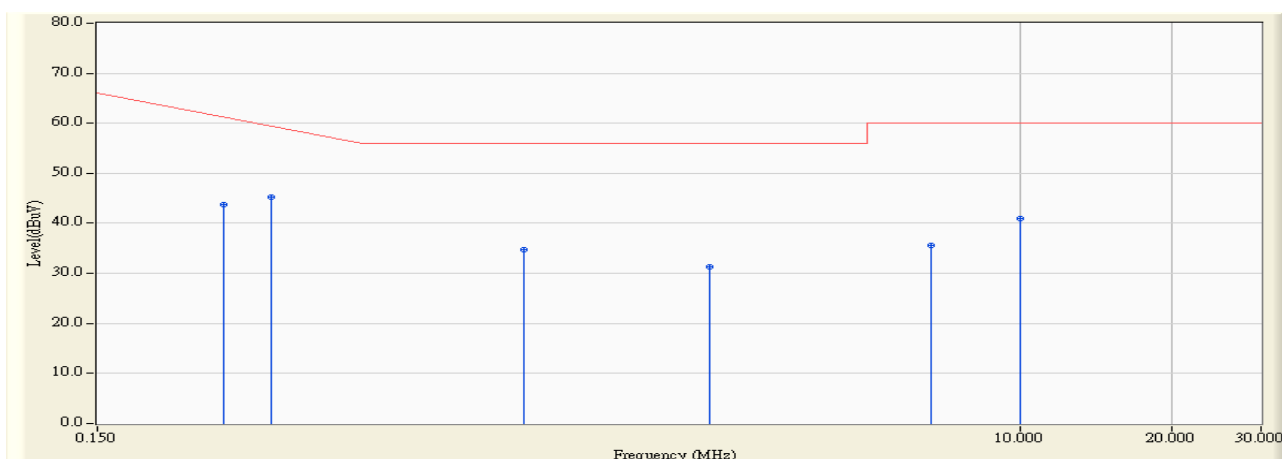

|   |   | Frequency (MHz) | Correct Factor (dB) | Reading Level (dBuV) | Measure Level (dBuV) | Margin (dB) | Limit (dBuV) | Detector Type |
|---|---|-----------------|---------------------|----------------------|----------------------|-------------|--------------|---------------|
| 1 |   | 0.267           | 9.854               | 33.960               | 43.814               | -18.843     | 62.657       | QUASPEAK      |
| 2 | * | 0.330           | 9.850               | 35.500               | 45.350               | -15.507     | 60.857       | QUASPEAK      |
| 3 |   | 1.048           | 9.830               | 24.900               | 34.730               | -21.270     | 56.000       | QUASPEAK      |
| 4 |   | 2.439           | 9.850               | 21.450               | 31.300               | -24.700     | 56.000       | QUASPEAK      |
| 5 |   | 6.670           | 9.900               | 25.720               | 35.620               | -24.380     | 60.000       | QUASPEAK      |
| 6 |   | 10.013          | 9.930               | 30.990               | 40.920               | -19.080     | 60.000       | QUASPEAK      |

**Note:**

1. All Reading Levels are Quasi-Peak and average value.
2. " \* ", means this data is the worst emission level.
3. Measurement Level = Reading Level + Correct Factor

|                              |                           |
|------------------------------|---------------------------|
| Site : SR1                   | Time : 2009/06/29 - 23:32 |
| Limit : CISPR_B_00M_AV       | Margin : 0                |
| EUT : HP Smart Wi-Fi Display | Probe : ENV-216-N - Line2 |
| Power : AC 120V/60Hz         | Note : Mode 1             |

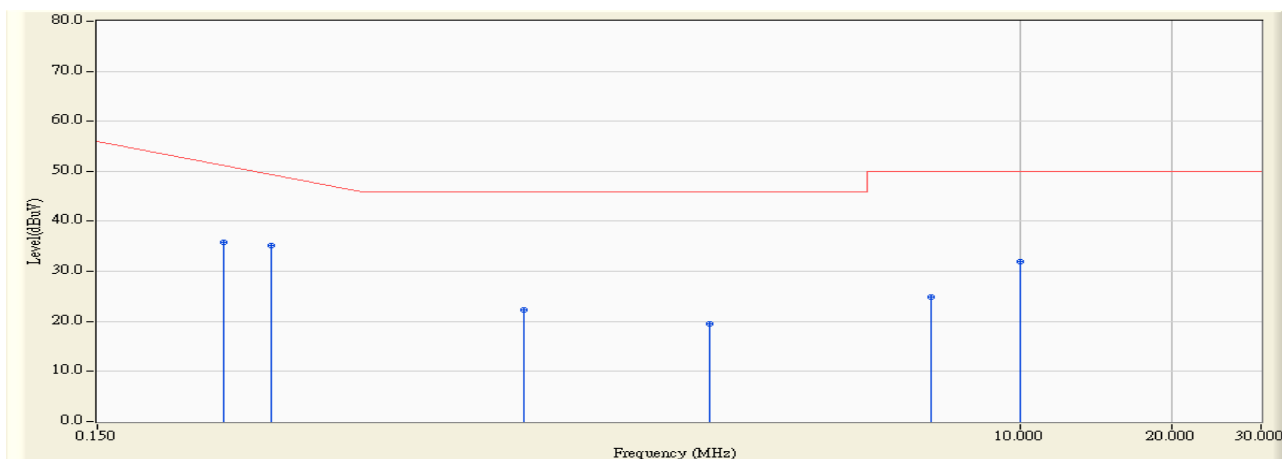

|   |   | Frequency (MHz) | Correct Factor (dB) | Reading Level (dBuV) | Measure Level (dBuV) | Margin (dB) | Limit (dBuV) | Detector Type |
|---|---|-----------------|---------------------|----------------------|----------------------|-------------|--------------|---------------|
| 1 |   | 0.267           | 9.854               | 26.060               | 35.914               | -16.743     | 52.657       | AVERAGE       |
| 2 | * | 0.330           | 9.850               | 25.300               | 35.150               | -15.707     | 50.857       | AVERAGE       |
| 3 |   | 1.048           | 9.830               | 12.380               | 22.210               | -23.790     | 46.000       | AVERAGE       |
| 4 |   | 2.439           | 9.850               | 9.670                | 19.520               | -26.480     | 46.000       | AVERAGE       |
| 5 |   | 6.670           | 9.900               | 15.050               | 24.950               | -25.050     | 50.000       | AVERAGE       |
| 6 |   | 10.013          | 9.930               | 22.130               | 32.060               | -17.940     | 50.000       | AVERAGE       |

**Note:**

1. All Reading Levels are Quasi-Peak and average value.
2. " \* ", means this data is the worst emission level.
3. Measurement Level = Reading Level + Correct Factor

|                              |                            |
|------------------------------|----------------------------|
| Site : SR1                   | Time : 2009/06/30 - 00:02  |
| Limit : CISPR_B_00M_QP       | Margin : 10                |
| EUT : HP Smart Wi-Fi Display | Probe : ENV-216-L1 - Line1 |
| Power : AC 120V/60Hz         | Note : Mode 5              |

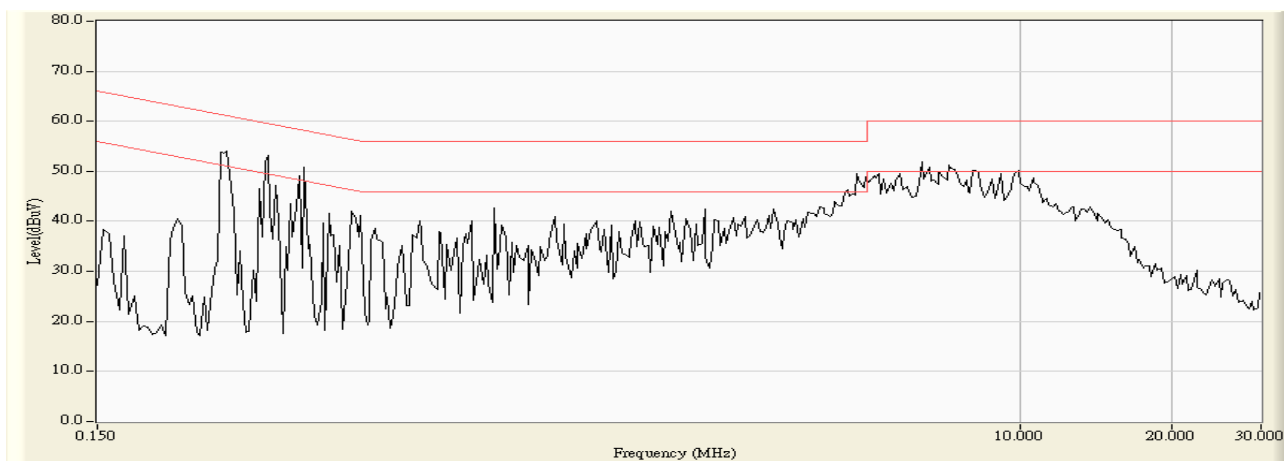

|                              |                            |
|------------------------------|----------------------------|
| Site : SR1                   | Time : 2009/06/30 - 00:04  |
| Limit : CISPR_B_00M_QP       | Margin : 0                 |
| EUT : HP Smart Wi-Fi Display | Probe : ENV-216-L1 - Line1 |
| Power : AC 120V/60Hz         | Note : Mode 5              |

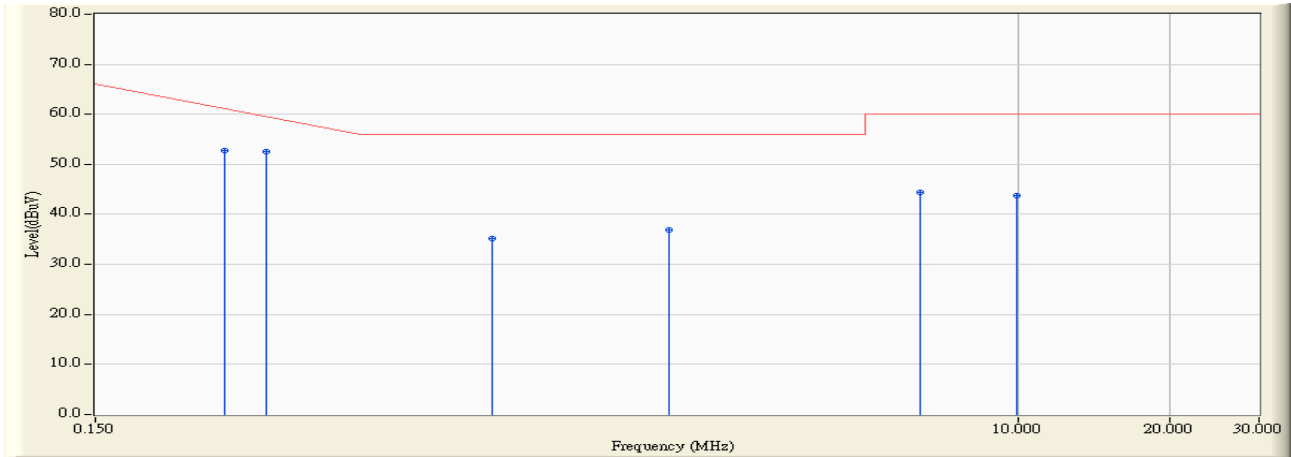

|   |   | Frequency (MHz) | Correct Factor (dB) | Reading Level (dBuV) | Measure Level (dBuV) | Margin (dB) | Limit (dBuV) | Detector Type |
|---|---|-----------------|---------------------|----------------------|----------------------|-------------|--------------|---------------|
| 1 |   | 0.271           | 9.830               | 42.930               | 52.760               | -9.783      | 62.543       | QUASPEAK      |
| 2 | * | 0.326           | 9.830               | 42.660               | 52.490               | -8.481      | 60.971       | QUASPEAK      |
| 3 |   | 0.912           | 9.830               | 25.370               | 35.200               | -20.800     | 56.000       | QUASPEAK      |
| 4 |   | 2.048           | 9.850               | 27.110               | 36.960               | -19.040     | 56.000       | QUASPEAK      |
| 5 |   | 6.420           | 9.880               | 34.600               | 44.480               | -15.520     | 60.000       | QUASPEAK      |
| 6 |   | 9.951           | 9.920               | 33.930               | 43.850               | -16.150     | 60.000       | QUASPEAK      |

**Note:**

1. All Reading Levels are Quasi-Peak and average value.
2. " \* ", means this data is the worst emission level.
3. Measurement Level = Reading Level + Correct Factor



|                              |                            |
|------------------------------|----------------------------|
| Site : SR1                   | Time : 2009/06/30 - 00:04  |
| Limit : CISPR_B_00M_AV       | Margin : 0                 |
| EUT : HP Smart Wi-Fi Display | Probe : ENV-216-L1 - Line1 |
| Power : AC 120V/60Hz         | Note : Mode 5              |

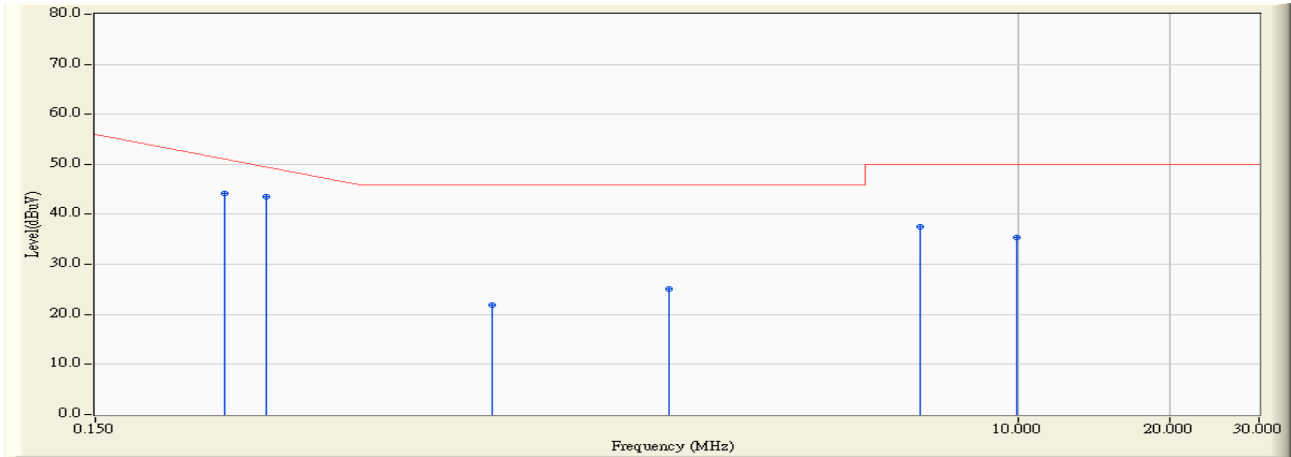

|   |   | Frequency (MHz) | Correct Factor (dB) | Reading Level (dBuV) | Measure Level (dBuV) | Margin (dB) | Limit (dBuV) | Detector Type |
|---|---|-----------------|---------------------|----------------------|----------------------|-------------|--------------|---------------|
| 1 |   | 0.271           | 9.830               | 34.310               | 44.140               | -8.403      | 52.543       | AVERAGE       |
| 2 | * | 0.326           | 9.830               | 33.640               | 43.470               | -7.501      | 50.971       | AVERAGE       |
| 3 |   | 0.912           | 9.830               | 12.070               | 21.900               | -24.100     | 46.000       | AVERAGE       |
| 4 |   | 2.048           | 9.850               | 15.340               | 25.190               | -20.810     | 46.000       | AVERAGE       |
| 5 |   | 6.420           | 9.880               | 27.710               | 37.590               | -12.410     | 50.000       | AVERAGE       |
| 6 |   | 9.951           | 9.920               | 25.380               | 35.300               | -14.700     | 50.000       | AVERAGE       |

**Note:**

1. All Reading Levels are Quasi-Peak and average value.
2. " \* ", means this data is the worst emission level.
3. Measurement Level = Reading Level + Correct Factor

|                              |                           |
|------------------------------|---------------------------|
| Site : SR1                   | Time : 2009/06/30 - 00:04 |
| Limit : CISPR_B_00M_QP       | Margin : 10               |
| EUT : HP Smart Wi-Fi Display | Probe : ENV-216-N - Line2 |
| Power : AC 120V/60Hz         | Note : Mode 5             |

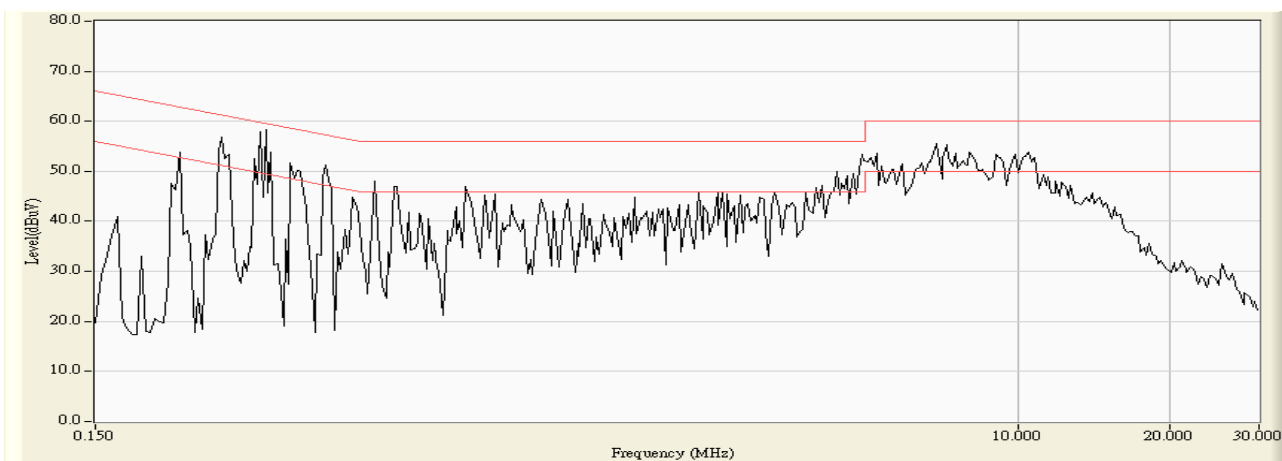

|                              |                           |
|------------------------------|---------------------------|
| Site : SR1                   | Time : 2009/06/30 - 00:05 |
| Limit : CISPR_B_00M_QP       | Margin : 0                |
| EUT : HP Smart Wi-Fi Display | Probe : ENV-216-N - Line2 |
| Power : AC 120V/60Hz         | Note : Mode 5             |

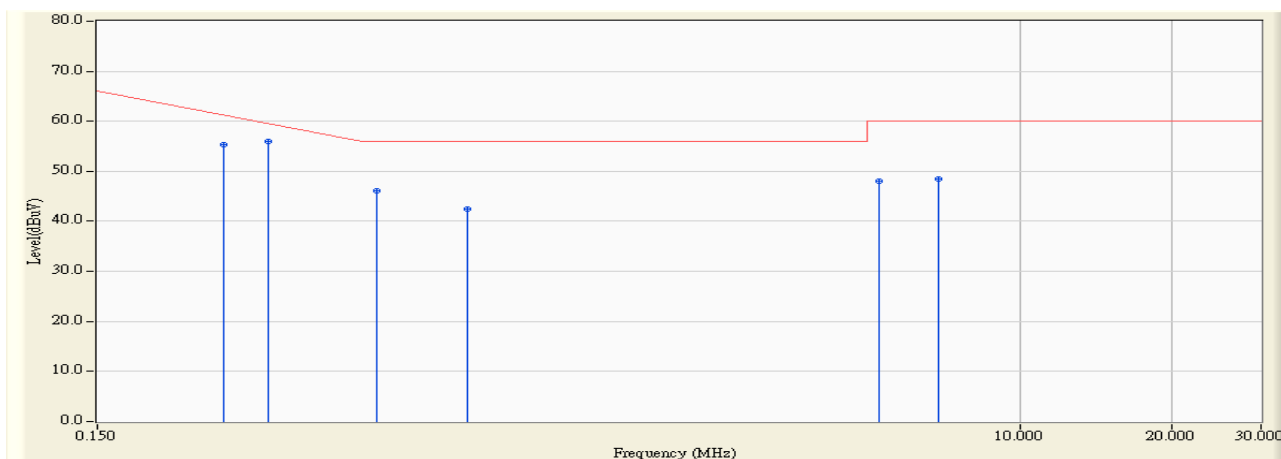

|   |   | Frequency (MHz) | Correct Factor (dB) | Reading Level (dBuV) | Measure Level (dBuV) | Margin (dB) | Limit (dBuV) | Detector Type |
|---|---|-----------------|---------------------|----------------------|----------------------|-------------|--------------|---------------|
| 1 |   | 0.267           | 9.854               | 45.530               | 55.384               | -7.273      | 62.657       | QUASPEAK      |
| 2 | * | 0.326           | 9.850               | 46.050               | 55.900               | -5.071      | 60.971       | QUASPEAK      |
| 3 |   | 0.537           | 9.830               | 36.180               | 46.010               | -9.990      | 56.000       | QUASPEAK      |
| 4 |   | 0.810           | 9.830               | 32.600               | 42.430               | -13.570     | 56.000       | QUASPEAK      |
| 5 |   | 5.263           | 9.870               | 38.190               | 48.060               | -11.940     | 60.000       | QUASPEAK      |
| 6 |   | 6.911           | 9.900               | 38.590               | 48.490               | -11.510     | 60.000       | QUASPEAK      |

**Note:**

1. All Reading Levels are Quasi-Peak and average value.
2. " \* ", means this data is the worst emission level.
3. Measurement Level = Reading Level + Correct Factor

|                              |                           |
|------------------------------|---------------------------|
| Site : SR1                   | Time : 2009/06/30 - 00:05 |
| Limit : CISPR_B_00M_AV       | Margin : 0                |
| EUT : HP Smart Wi-Fi Display | Probe : ENV-216-N - Line2 |
| Power : AC 120V/60Hz         | Note : Mode 5             |

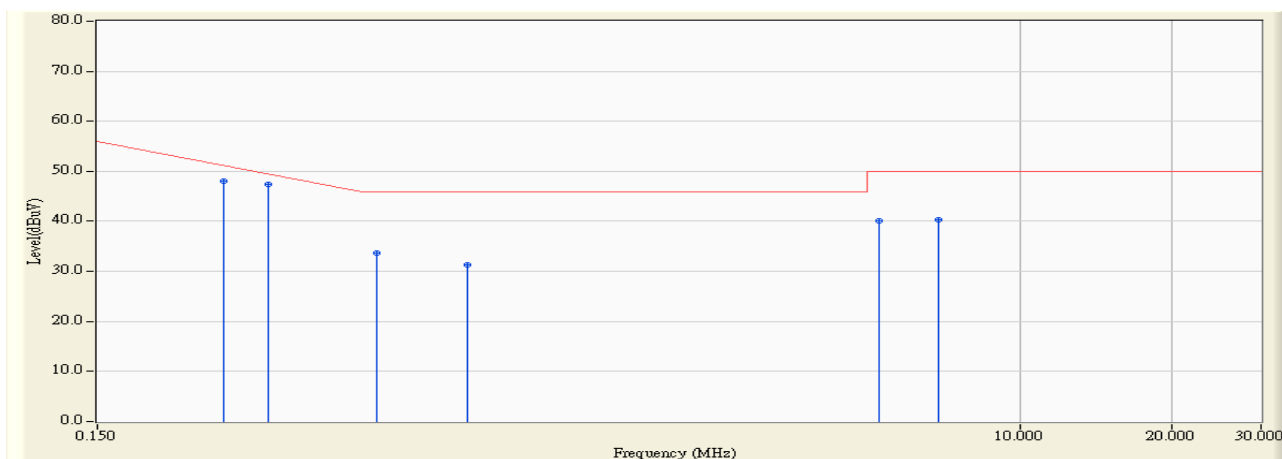

|   |   | Frequency (MHz) | Correct Factor (dB) | Reading Level (dBuV) | Measure Level (dBuV) | Margin (dB) | Limit (dBuV) | Detector Type |
|---|---|-----------------|---------------------|----------------------|----------------------|-------------|--------------|---------------|
| 1 |   | 0.267           | 9.854               | 38.170               | 48.024               | -4.633      | 52.657       | AVERAGE       |
| 2 | * | 0.326           | 9.850               | 37.460               | 47.310               | -3.661      | 50.971       | AVERAGE       |
| 3 |   | 0.537           | 9.830               | 23.930               | 33.760               | -12.240     | 46.000       | AVERAGE       |
| 4 |   | 0.810           | 9.830               | 21.400               | 31.230               | -14.770     | 46.000       | AVERAGE       |
| 5 |   | 5.263           | 9.870               | 30.190               | 40.060               | -9.940      | 50.000       | AVERAGE       |
| 6 |   | 6.911           | 9.900               | 30.510               | 40.410               | -9.590      | 50.000       | AVERAGE       |

**Note:**

1. All Reading Levels are Quasi-Peak and average value.
2. " \* ", means this data is the worst emission level.
3. Measurement Level = Reading Level + Correct Factor

|                              |                            |
|------------------------------|----------------------------|
| Site : SR1                   | Time : 2009/07/17 - 22:05  |
| Limit : CISPR_B_00M_QP       | Margin : 10                |
| EUT : HP Smart Wi-Fi Display | Probe : ENV-216-L1 - Line1 |
| Power : AC 120V/60Hz         | Note : Mode 7              |

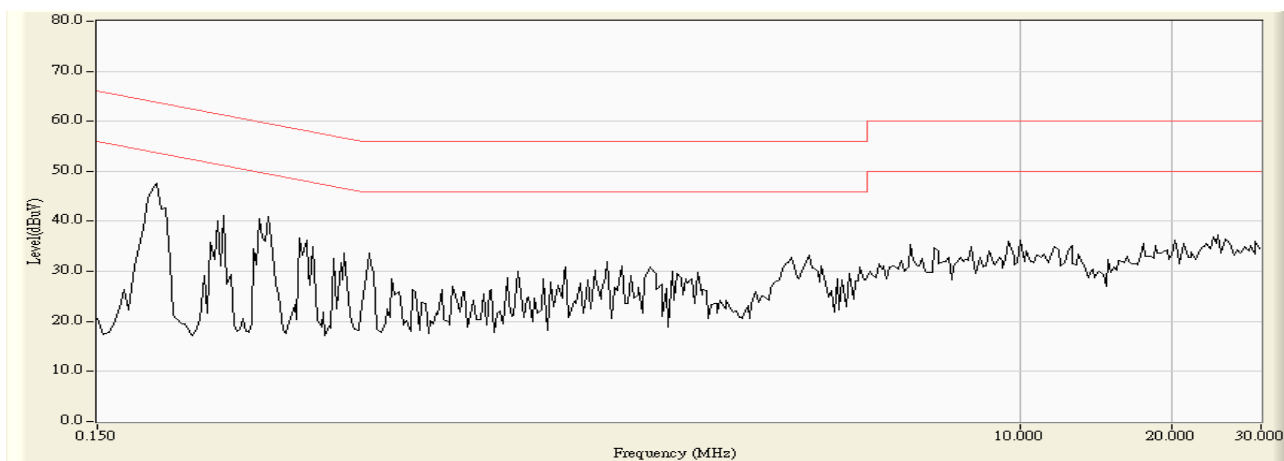

|                              |                            |
|------------------------------|----------------------------|
| Site : SR1                   | Time : 2009/07/17 - 22:06  |
| Limit : CISPR_B_00M_QP       | Margin : 0                 |
| EUT : HP Smart Wi-Fi Display | Probe : ENV-216-L1 - Line1 |
| Power : AC 120V/60Hz         | Note : Mode 7              |

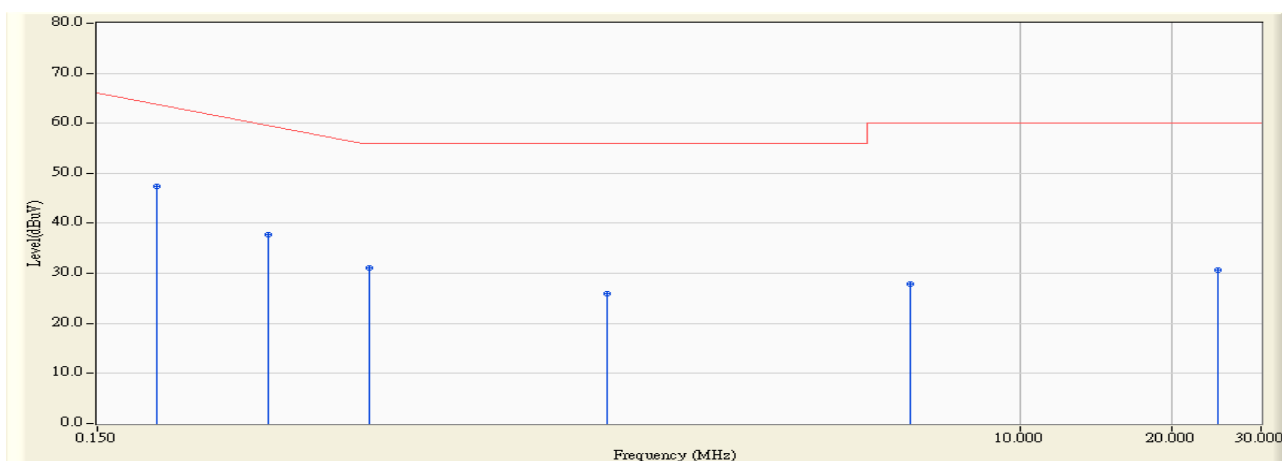

|   |   | Frequency (MHz) | Correct Factor (dB) | Reading Level (dBuV) | Measure Level (dBuV) | Margin (dB) | Limit (dBuV) | Detector Type |
|---|---|-----------------|---------------------|----------------------|----------------------|-------------|--------------|---------------|
| 1 | * | 0.197           | 9.823               | 37.590               | 47.413               | -17.244     | 64.657       | QUASPEAK      |
| 2 |   | 0.326           | 9.830               | 27.960               | 37.790               | -23.181     | 60.971       | QUASPEAK      |
| 3 |   | 0.517           | 9.820               | 21.270               | 31.090               | -24.910     | 56.000       | QUASPEAK      |
| 4 |   | 1.529           | 9.840               | 16.130               | 25.970               | -30.030     | 56.000       | QUASPEAK      |
| 5 |   | 6.095           | 9.880               | 17.940               | 27.820               | -32.180     | 60.000       | QUASPEAK      |
| 6 |   | 24.705          | 10.240              | 20.470               | 30.710               | -29.290     | 60.000       | QUASPEAK      |

**Note:**

1. All Reading Levels are Quasi-Peak and average value.
2. " \* ", means this data is the worst emission level.
3. Measurement Level = Reading Level + Correct Factor

|                              |                            |
|------------------------------|----------------------------|
| Site : SR1                   | Time : 2009/07/17 - 22:06  |
| Limit : CISPR_B_00M_AV       | Margin : 0                 |
| EUT : HP Smart Wi-Fi Display | Probe : ENV-216-L1 - Line1 |
| Power : AC 120V/60Hz         | Note : Mode 7              |

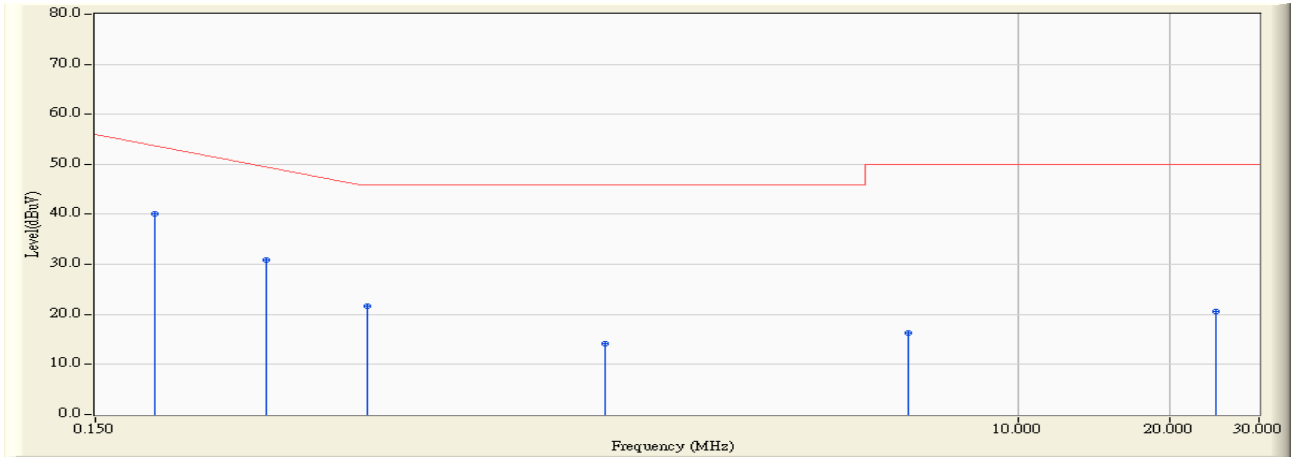

|   |   | Frequency (MHz) | Correct Factor (dB) | Reading Level (dBuV) | Measure Level (dBuV) | Margin (dB) | Limit (dBuV) | Detector Type |
|---|---|-----------------|---------------------|----------------------|----------------------|-------------|--------------|---------------|
| 1 | * | 0.197           | 9.823               | 30.210               | 40.033               | -14.624     | 54.657       | AVERAGE       |
| 2 |   | 0.326           | 9.830               | 21.010               | 30.840               | -20.131     | 50.971       | AVERAGE       |
| 3 |   | 0.517           | 9.820               | 11.790               | 21.610               | -24.390     | 46.000       | AVERAGE       |
| 4 |   | 1.529           | 9.840               | 4.420                | 14.260               | -31.740     | 46.000       | AVERAGE       |
| 5 |   | 6.095           | 9.880               | 6.410                | 16.290               | -33.710     | 50.000       | AVERAGE       |
| 6 |   | 24.705          | 10.240              | 10.420               | 20.660               | -29.340     | 50.000       | AVERAGE       |

**Note:**

1. All Reading Levels are Quasi-Peak and average value.
2. " \* ", means this data is the worst emission level.
3. Measurement Level = Reading Level + Correct Factor

|                              |                           |
|------------------------------|---------------------------|
| Site : SR1                   | Time : 2009/07/17 - 22:06 |
| Limit : CISPR_B_00M_QP       | Margin : 10               |
| EUT : HP Smart Wi-Fi Display | Probe : ENV-216-N - Line2 |
| Power : AC 120V/60Hz         | Note : Mode 7             |

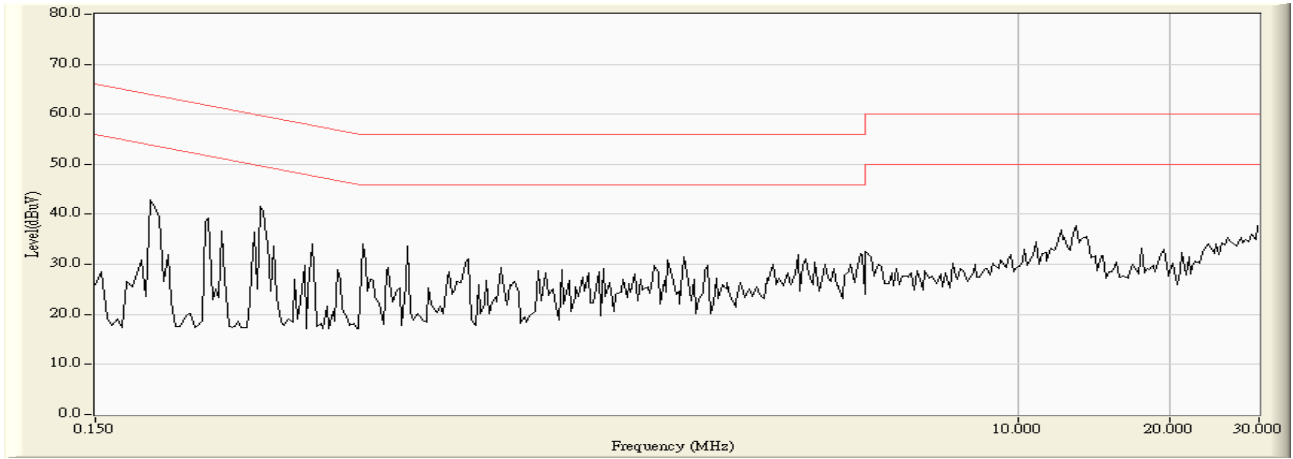



|                              |                           |
|------------------------------|---------------------------|
| Site : SR1                   | Time : 2009/07/17 - 22:07 |
| Limit : CISPR_B_00M_QP       | Margin : 0                |
| EUT : HP Smart Wi-Fi Display | Probe : ENV-216-N - Line2 |
| Power : AC 120V/60Hz         | Note : Mode 7             |

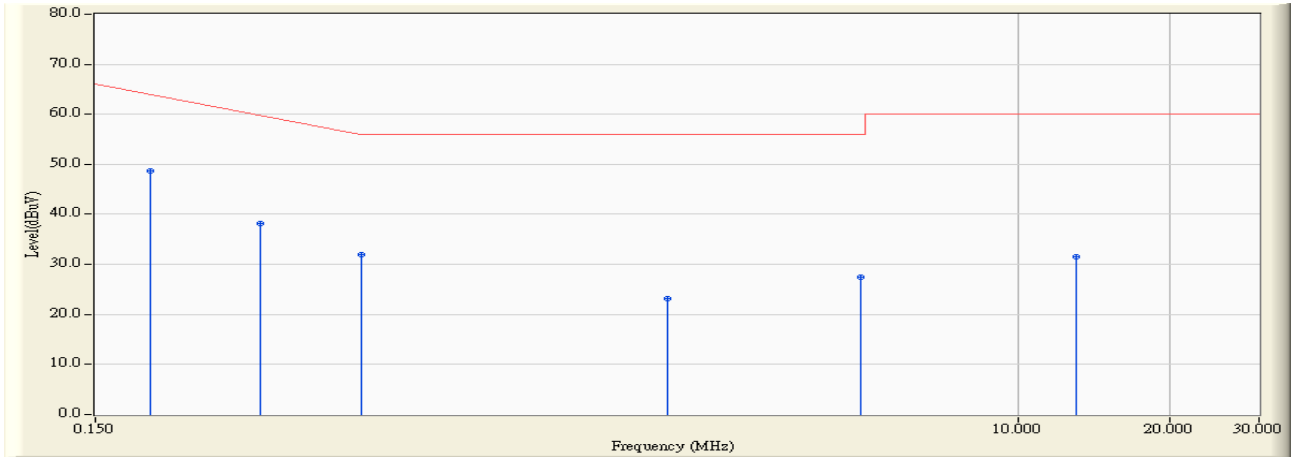

|   |   | Frequency (MHz) | Correct Factor (dB) | Reading Level (dBuV) | Measure Level (dBuV) | Margin (dB) | Limit (dBuV) | Detector Type |
|---|---|-----------------|---------------------|----------------------|----------------------|-------------|--------------|---------------|
| 1 | * | 0.193           | 9.860               | 38.920               | 48.780               | -15.991     | 64.771       | QUASPEAK      |
| 2 |   | 0.318           | 9.850               | 28.240               | 38.090               | -23.110     | 61.200       | QUASPEAK      |
| 3 |   | 0.505           | 9.830               | 22.220               | 32.050               | -23.950     | 56.000       | QUASPEAK      |
| 4 |   | 2.025           | 9.850               | 13.330               | 23.180               | -32.820     | 56.000       | QUASPEAK      |
| 5 |   | 4.880           | 9.870               | 17.560               | 27.430               | -28.570     | 56.000       | QUASPEAK      |
| 6 |   | 13.033          | 10.141              | 21.460               | 31.601               | -28.399     | 60.000       | QUASPEAK      |

**Note:**

1. All Reading Levels are Quasi-Peak and average value.
2. " \* ", means this data is the worst emission level.
3. Measurement Level = Reading Level + Correct Factor

|                              |                           |
|------------------------------|---------------------------|
| Site : SR1                   | Time : 2009/07/17 - 22:07 |
| Limit : CISPR_B_00M_AV       | Margin : 0                |
| EUT : HP Smart Wi-Fi Display | Probe : ENV-216-N - Line2 |
| Power : AC 120V/60Hz         | Note : Mode 7             |

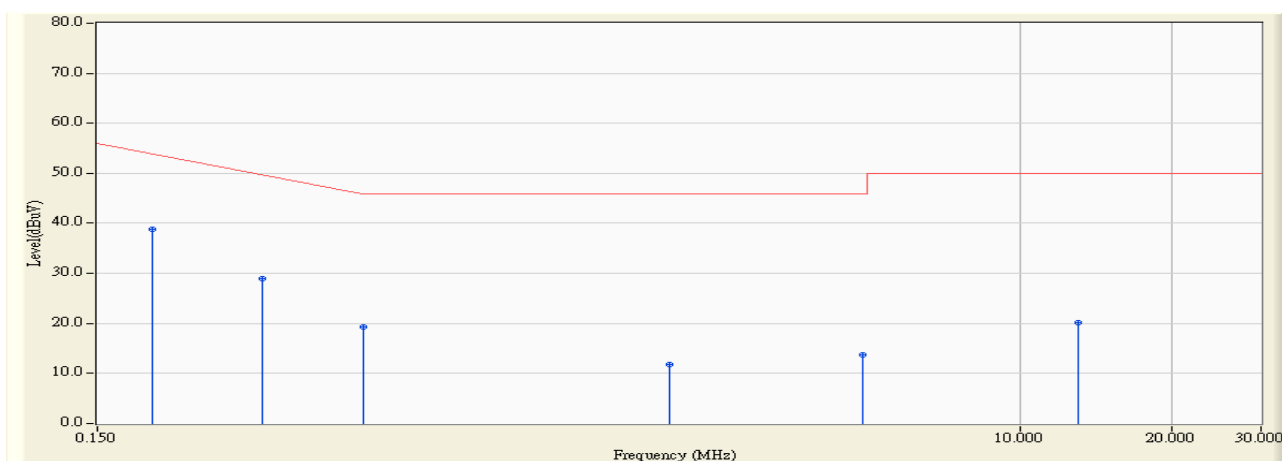

|   |   | Frequency (MHz) | Correct Factor (dB) | Reading Level (dBuV) | Measure Level (dBuV) | Margin (dB) | Limit (dBuV) | Detector Type |
|---|---|-----------------|---------------------|----------------------|----------------------|-------------|--------------|---------------|
| 1 | * | 0.193           | 9.860               | 29.020               | 38.880               | -15.891     | 54.771       | AVERAGE       |
| 2 |   | 0.318           | 9.850               | 19.130               | 28.980               | -22.220     | 51.200       | AVERAGE       |
| 3 |   | 0.505           | 9.830               | 9.550                | 19.380               | -26.620     | 46.000       | AVERAGE       |
| 4 |   | 2.025           | 9.850               | 1.990                | 11.840               | -34.160     | 46.000       | AVERAGE       |
| 5 |   | 4.880           | 9.870               | 3.830                | 13.700               | -32.300     | 46.000       | AVERAGE       |
| 6 |   | 13.033          | 10.141              | 10.080               | 20.221               | -29.779     | 50.000       | AVERAGE       |

**Note:**

1. All Reading Levels are Quasi-Peak and average value.
2. " \* ", means this data is the worst emission level.
3. Measurement Level = Reading Level + Correct Factor

### 3.6. Test Photograph

Test Mode : Mode 1: Video with Flash + WLAN Mode with DVE Adapter

Description : Front View of Conducted Test



Test Mode : Mode 1: Video with Flash + WLAN Mode with DVE Adapter

Description : Back View of Conducted Test



Test Mode : Mode 5: Link PC Mode

Description : Front View of Conducted Test



Test Mode : Mode 5: Link PC Mode

Description : Back View of Conducted Test



Test Mode : Mode 7: Video with Flash + WLAN Mode with Powertron Adapter

Description : Front View of Conducted Test



Test Mode : Mode 7: Video with Flash + WLAN Mode with Powertron Adapter

Description : Back View of Conducted Test



## 4. Radiated Emission

### 4.1. Test Specification

According to EMC Standard : FCC Part 15 Subpart B, ANSI C63.4

### 4.2. Test Setup

Under 1GHz Test Setup:

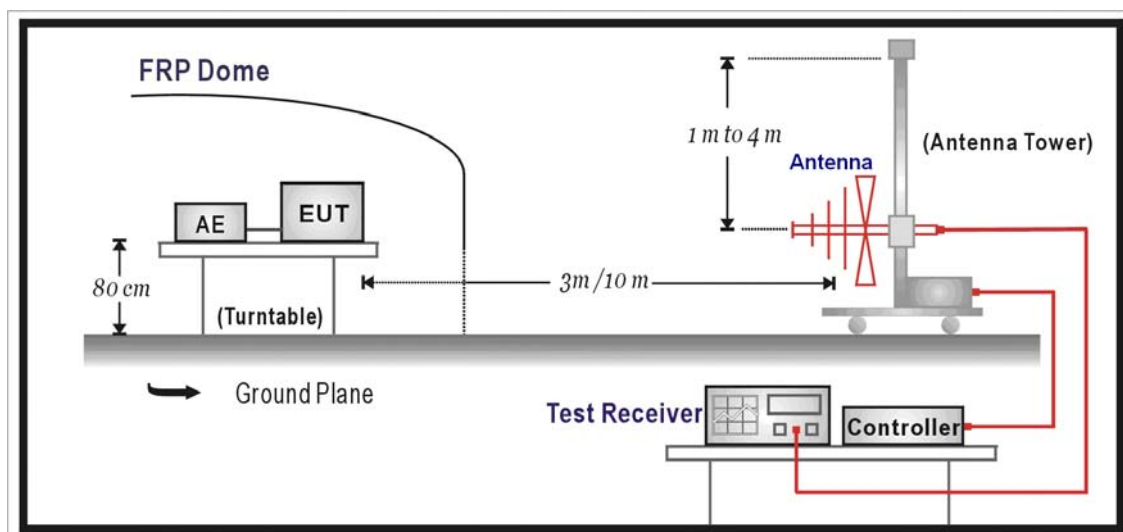

Above 1GHz Test Setup:

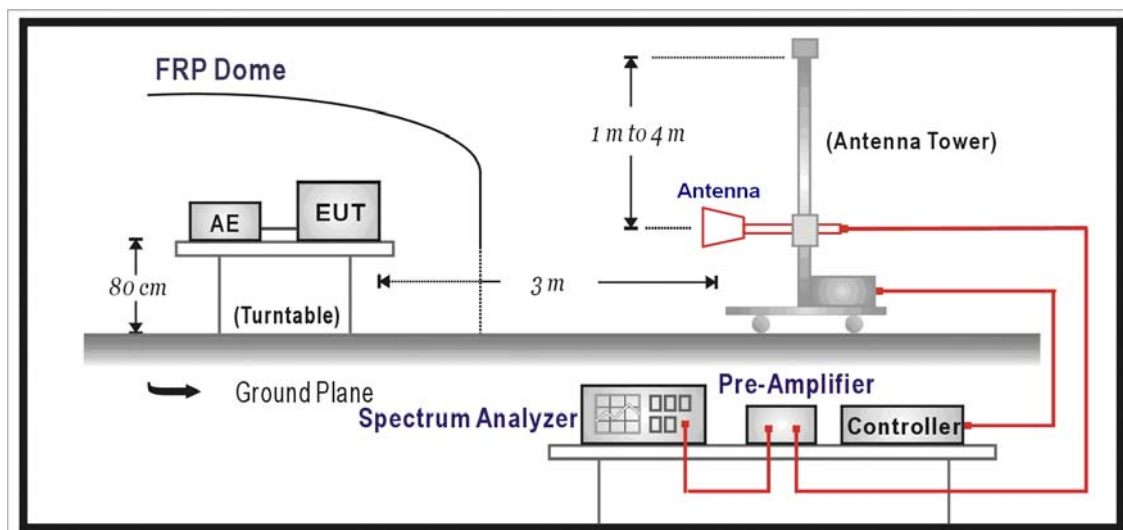

4.3. Limit

Under 1GHz test shall not exceed the following value:

| Limits          |              |        |
|-----------------|--------------|--------|
| Frequency (MHz) | Distance (m) | dBuV/m |
| 30 – 230        | 10           | 30     |
| 230 – 1000      | 10           | 37     |

Remark:

1. The tighter limit shall apply at the edge between two frequency bands.
2. Distance refers to the distance in meters between the measuring instrument antenna and the closed point of any part of the device or system.

Above 1GHz test shall not exceed the following value:

| FCC Part 15 Subpart B Paragraph 15.109 Limits (dBuV/m) |              |        |
|--|--------------|--------|
| Frequency (MHz)  | Distance (m) | dBuV/m |
| 30-88  | 3            | 40     |
| 88-216   | 3            | 43.5   |
| 216-960  | 3            | 46     |
| Above 960  | 3            | 54     |

Remark:

1. The tighter limit shall apply at the edge between two frequency bands.
2. Distance refers to the distance in meters between the measuring instrument antenna and the closed point of any part of the device or system.
3. RF Voltage (dBuV/m) = 20 log RF Voltage (uV/m)

**4.4. Test Procedure**

The EUT and its simulators are placed on a turn table which is 0.8 meter above ground.

The turn table can rotate 360 degrees to determine the position of the maximum emission level and the antenna can move up and down between 1 meter and 4 meters to find out the maximum emission level.

Both horizontal and vertical polarization of the antenna are set on measurement. In order to find the maximum emission, all of the interface cables must be manipulated on radiated measurement.

For an unintentional radiator, including a digital device, the spectrum shall be investigated from the lowest radio frequency signal generated or used in the device, without going below the lowest frequency for which a radiated emission limit is specified, up to the frequency shown in the following table:

| Highest frequency generated or used in the device or on which the device operates or tunes (MHz) | Upper frequency of measurement range (MHz)                                      |
|--|---|
| Below 1.705  | 30  |
| 1.705 – 108  | 1000  |
| 108 – 500  | 2000  |
| 500 – 1000   | 5000  |
| Above 1000   | 5 <sup>th</sup> harmonic of the highest frequency or 40 GHz, whichever is lower |

On any frequency or frequencies below or equal to 1000 MHz, the radiated limits shown are based on measuring equipment employing a quasi-peak detector function and above 1000 MHz, the radiated limits shown are based measuring equipment employing an average detector function.

When average radiated emission measurement are included emission measurement Above 1000 MHz, there also is a limit on the radio frequency emissions, as measured using instrumentation with a peak detector function, corresponding to 20 dB above the maximum permitted average limit.

For class A, the measurement distance between the EUT and antenna is 10 meters for under 1GHz and above 1GHz.

For class B, the measurement distance between the EUT and antenna is 10 meters for under 1GHz and 3 meters for above 1GHz.

The bandwidth below 1GHz setting on the field strength meter (R&S Test Receiver ESCS 30) is 120 kHz and above 1GHz is 1MHz.



## 4.5. Test Result

|                              |                                       |
|------------------------------|---------------------------------------|
| Site : OATS-6                | Time : 2009/06/29 - 16:25             |
| Limit : FCC_CLASS_B_03M_QP   | Margin : 6                            |
| EUT : HP Smart Wi-Fi Display | Probe : site6_3M_2008_06 - HORIZONTAL |
| Power : AC 120V/60Hz         | Note : Mode 1                         |

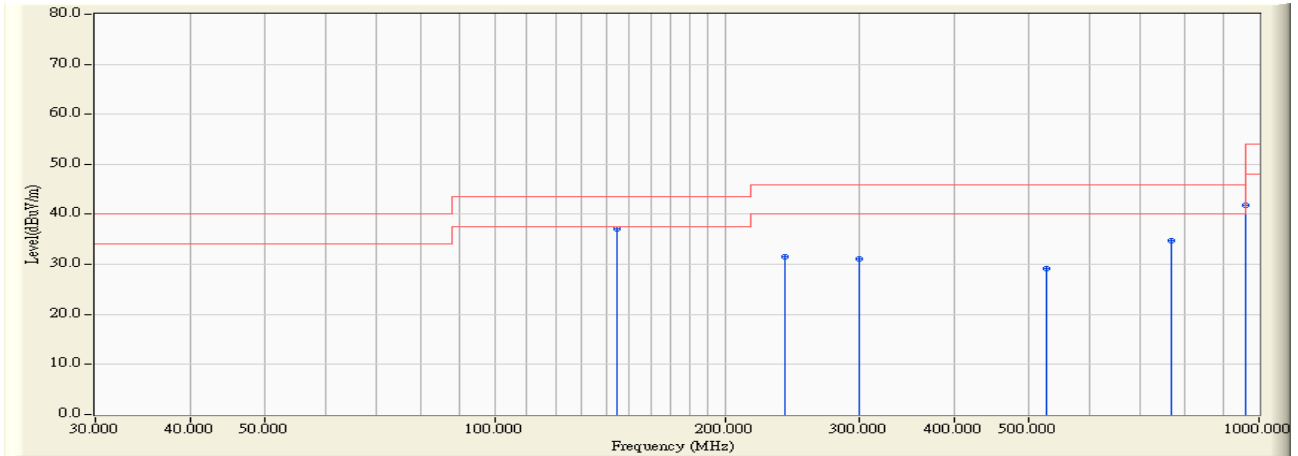

|   | Frequency (MHz) | Correct Factor (dB) | Reading Level (dBuV) | Measure Level (dBuV/m) | Margin (dB) | Limit (dBuV/m) | Detector Type |
|---|-----------------|---------------------|----------------------|------------------------|-------------|----------------|---------------|
| 1 | 144.400         | 10.733              | 26.400               | 37.134                 | -6.366      | 43.500         | QUASPEAK      |
| 2 | 240.013         | 12.316              | 19.200               | 31.516                 | -14.484     | 46.000         | QUASPEAK      |
| 3 | 300.300         | 15.997              | 15.000               | 30.997                 | -15.003     | 46.000         | QUASPEAK      |
| 4 | 528.002         | 20.966              | 8.300                | 29.266                 | -16.734     | 46.000         | QUASPEAK      |
| 5 | 768.600         | 26.965              | 7.700                | 34.665                 | -11.335     | 46.000         | QUASPEAK      |
| 6 | * 960.000       | 30.793              | 11.000               | 41.792                 | -4.208      | 46.000         | QUASPEAK      |

**Note:**

1. All Readings below 1GHz are Quasi-Peak, above are performed with peak and/or average measurements as necessary.
2. " \* ", means this data is the worst emission level.
3. Measurement Level = Reading Level + Correct Factor

|                              |                                     |
|------------------------------|-------------------------------------|
| Site : OATS-6                | Time : 2009/06/29 - 16:24           |
| Limit : FCC_CLASS_B_03M_QP   | Margin : 6                          |
| EUT : HP Smart Wi-Fi Display | Probe : site6_3M_2008_06 - VERTICAL |
| Power : AC 120V/60Hz         | Note : Mode 1                       |

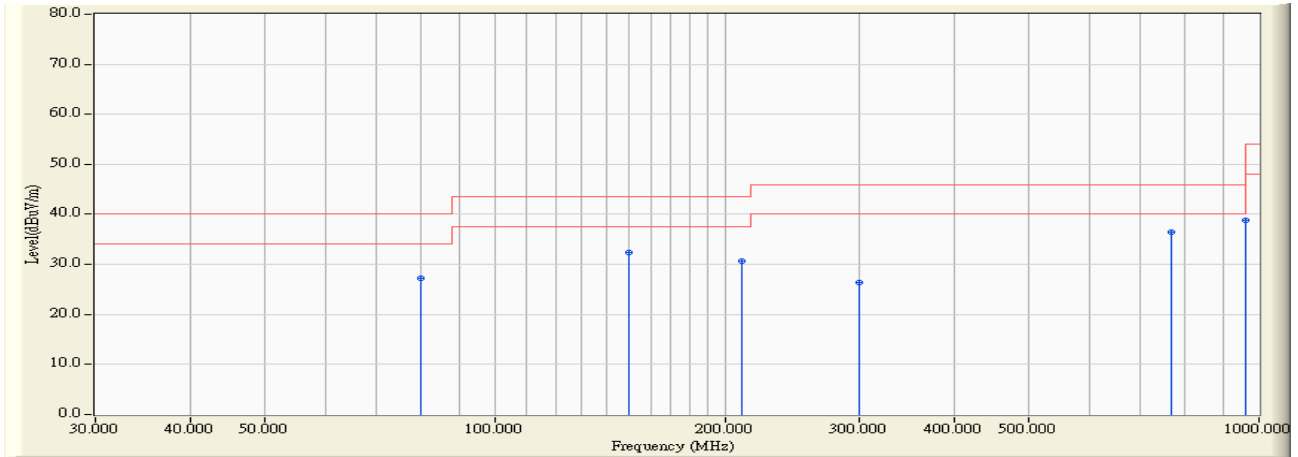

|   | Frequency (MHz) | Correct Factor (dB) | Reading Level (dBuV) | Measure Level (dBuV/m) | Margin (dB) | Limit (dBuV/m) | Detector Type |
|---|-----------------|---------------------|----------------------|------------------------|-------------|----------------|---------------|
| 1 | 79.860          | 8.560               | 18.600               | 27.160                 | -12.840     | 40.000         | QUASPEAK      |
| 2 | 150.006         | 13.061              | 19.300               | 32.362                 | -11.138     | 43.500         | QUASPEAK      |
| 3 | 210.000         | 9.479               | 21.200               | 30.679                 | -12.821     | 43.500         | QUASPEAK      |
| 4 | 300.000         | 14.251              | 12.100               | 26.351                 | -19.649     | 46.000         | QUASPEAK      |
| 5 | 768.613         | 27.207              | 9.300                | 36.507                 | -9.493      | 46.000         | QUASPEAK      |
| 6 | * 960.000       | 27.467              | 11.300               | 38.767                 | -7.233      | 46.000         | QUASPEAK      |

**Note:**

1. All Readings below 1GHz are Quasi-Peak, above are performed with peak and/or average measurements as necessary.
2. " \* ", means this data is the worst emission level.
3. Measurement Level = Reading Level + Correct Factor

|                              |                                       |
|------------------------------|---------------------------------------|
| Site : OATS-6                | Time : 2009/06/03 - 10:37             |
| Limit : FCC_CLASS_B_03M_QP   | Margin : 6                            |
| EUT : HP Smart Wi-Fi Display | Probe : site6_3M_2008_06 - HORIZONTAL |
| Power : AC 120V/60Hz         | Note : Mode 5                         |

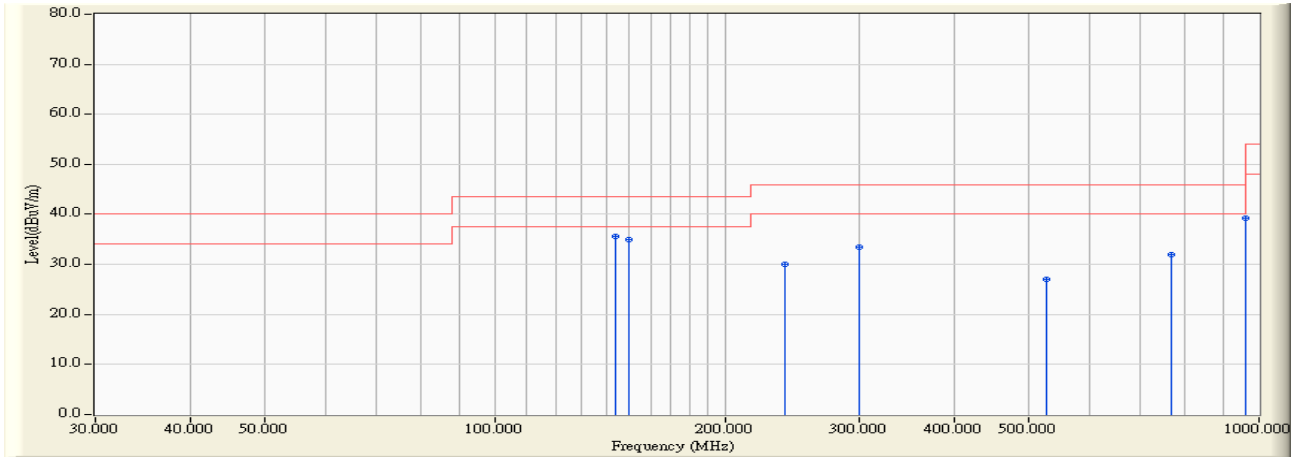

|   | Frequency (MHz) | Correct Factor (dB) | Reading Level (dBuV) | Measure Level (dBuV/m) | Margin (dB) | Limit (dBuV/m) | Detector Type |
|---|-----------------|---------------------|----------------------|------------------------|-------------|----------------|---------------|
| 1 | 144.032         | 10.757              | 24.900               | 35.656                 | -7.844      | 43.500         | QUASIPeAK     |
| 2 | 150.003         | 10.506              | 24.400               | 34.906                 | -8.594      | 43.500         | QUASIPeAK     |
| 3 | 240.006         | 12.315              | 17.800               | 30.115                 | -15.885     | 46.000         | QUASIPeAK     |
| 4 | 300.006         | 15.994              | 17.500               | 33.494                 | -12.506     | 46.000         | QUASIPeAK     |
| 5 | 527.953         | 20.962              | 6.000                | 26.962                 | -19.038     | 46.000         | QUASIPeAK     |
| 6 | 768.587         | 26.966              | 5.000                | 31.966                 | -14.034     | 46.000         | QUASIPeAK     |
| 7 | * 960.000       | 30.793              | 8.500                | 39.292                 | -6.708      | 46.000         | QUASIPeAK     |

**Note:**

1. All Readings below 1GHz are Quasi-Peak, above are performed with peak and/or average measurements as necessary.
2. " \* ", means this data is the worst emission level.
3. Measurement Level = Reading Level + Correct Factor

|                              |                                     |
|------------------------------|-------------------------------------|
| Site : OATS-6                | Time : 2009/06/03 - 10:16           |
| Limit : FCC_CLASS_B_03M_QP   | Margin : 6                          |
| EUT : HP Smart Wi-Fi Display | Probe : site6_3M_2008_06 - VERTICAL |
| Power : AC 120V/60Hz         | Note : Mode 5                       |

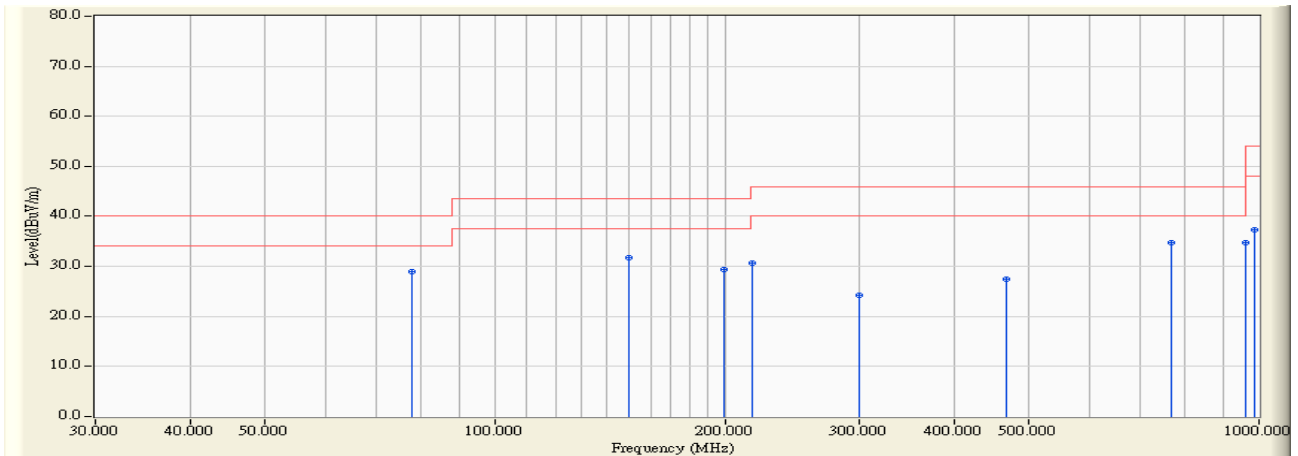

|   |   | Frequency (MHz) | Correct Factor (dB) | Reading Level (dBuV) | Measure Level (dBuV/m) | Margin (dB) | Limit (dBuV/m) | Detector Type |
|---|---|-----------------|---------------------|----------------------|------------------------|-------------|----------------|---------------|
| 1 | * | 78.000          | 8.404               | 20.500               | 28.903                 | -11.097     | 40.000         | QUASIPeAK     |
| 2 |   | 150.001         | 13.061              | 18.600               | 31.661                 | -11.839     | 43.500         | QUASIPeAK     |
| 3 |   | 199.200         | 11.358              | 18.000               | 29.359                 | -14.141     | 43.500         | QUASIPeAK     |
| 4 |   | 216.686         | 10.555              | 20.100               | 30.655                 | -15.345     | 46.000         | QUASIPeAK     |
| 5 |   | 300.000         | 14.251              | 10.000               | 24.251                 | -21.749     | 46.000         | QUASIPeAK     |
| 6 |   | 467.627         | 20.662              | 6.700                | 27.362                 | -18.638     | 46.000         | QUASIPeAK     |
| 7 |   | 768.600         | 27.208              | 7.600                | 34.808                 | -11.192     | 46.000         | QUASIPeAK     |
| 8 |   | 960.000         | 27.467              | 7.200                | 34.667                 | -11.333     | 46.000         | QUASIPeAK     |
| 9 |   | 988.188         | 26.658              | 10.700               | 37.358                 | -16.642     | 54.000         | QUASIPeAK     |

**Note:**

1. All Readings below 1GHz are Quasi-Peak, above are performed with peak and/or average measurements as necessary.
2. " \* ", means this data is the worst emission level.
3. Measurement Level = Reading Level + Correct Factor

|                              |                                       |
|------------------------------|---------------------------------------|
| Site : OATS-6                | Time : 2009/07/01 - 12:02             |
| Limit : FCC_CLASS_B_03M_QP   | Margin : 6                            |
| EUT : HP Smart Wi-Fi Display | Probe : site6_3M_2008_06 - HORIZONTAL |
| Power : AC 120V/60Hz         | Note : Mode 6                         |

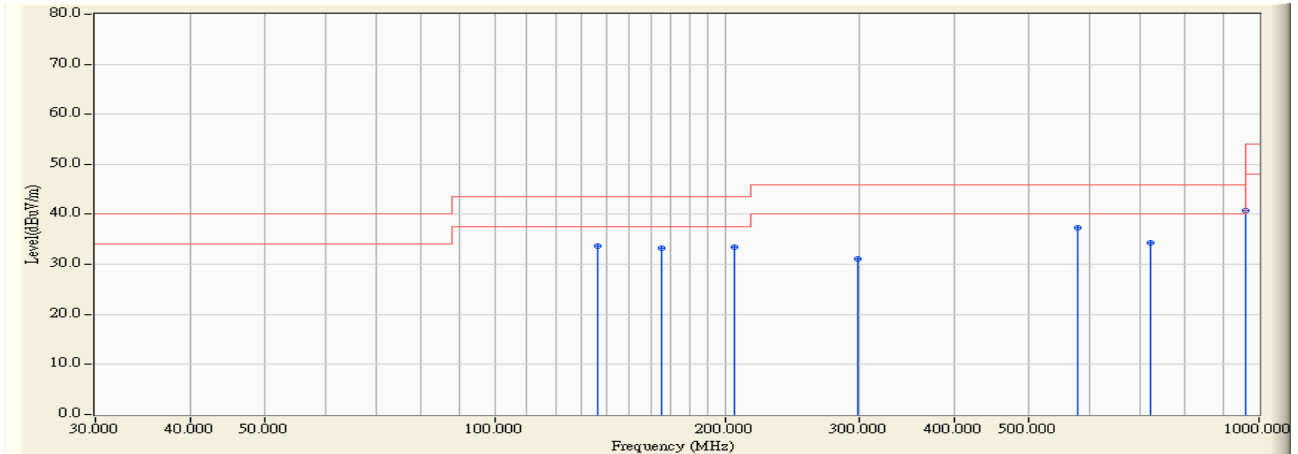

|   | Frequency (MHz) | Correct Factor (dB) | Reading Level (dBuV) | Measure Level (dBuV/m) | Margin (dB) | Limit (dBuV/m) | Detector Type |
|---|-----------------|---------------------|----------------------|------------------------|-------------|----------------|---------------|
| 1 | 136.330         | 11.361              | 22.300               | 33.661                 | -9.839      | 43.500         | QUASPEAK      |
| 2 | 165.042         | 9.006               | 24.300               | 33.306                 | -10.194     | 43.500         | QUASPEAK      |
| 3 | 205.972         | 10.319              | 23.100               | 33.419                 | -10.081     | 43.500         | QUASPEAK      |
| 4 | 298.361         | 14.297              | 16.700               | 30.997                 | -15.003     | 46.000         | QUASPEAK      |
| 5 | 577.812         | 25.733              | 11.600               | 37.333                 | -8.667      | 46.000         | QUASPEAK      |
| 6 | 721.548         | 26.702              | 7.600                | 34.302                 | -11.698     | 46.000         | QUASPEAK      |
| 7 | * 960.000       | 30.793              | 10.000               | 40.792                 | -5.208      | 46.000         | QUASPEAK      |

**Note:**

1. All Readings below 1GHz are Quasi-Peak, above are performed with peak and/or average measurements as necessary.
2. " \* ", means this data is the worst emission level.
3. Measurement Level = Reading Level + Correct Factor

|                              |                                     |
|------------------------------|-------------------------------------|
| Site : OATS-6                | Time : 2009/07/01 - 11:58           |
| Limit : FCC_CLASS_B_03M_QP   | Margin : 6                          |
| EUT : HP Smart Wi-Fi Display | Probe : site6_3M_2008_06 - VERTICAL |
| Power : AC 120V/60Hz         | Note : Mode 6                       |

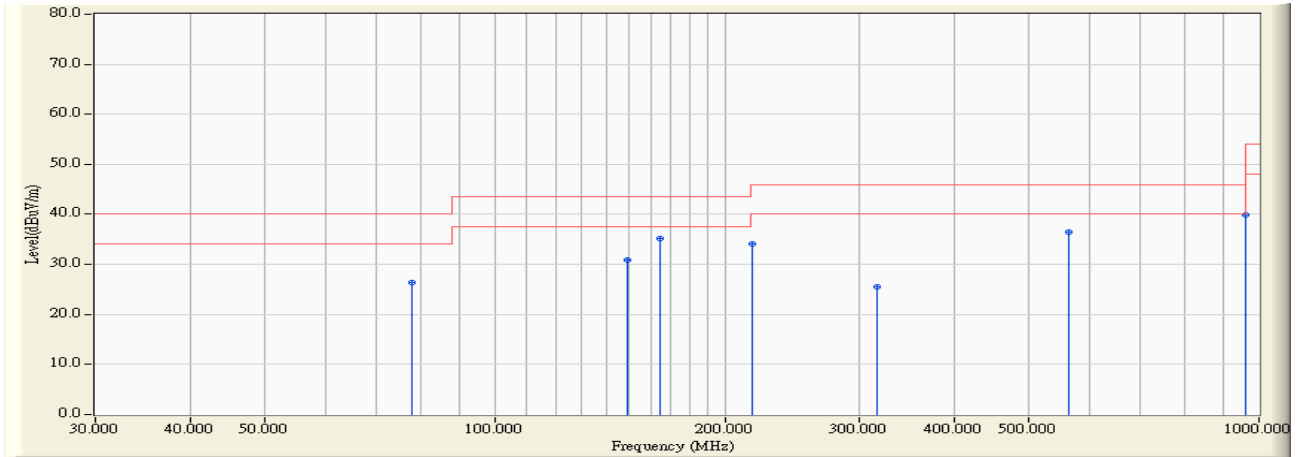

|   | Frequency (MHz) | Correct Factor (dB) | Reading Level (dBuV) | Measure Level (dBuV/m) | Margin (dB) | Limit (dBuV/m) | Detector Type |
|---|-----------------|---------------------|----------------------|------------------------|-------------|----------------|---------------|
| 1 | 77.840          | 8.385               | 18.000               | 26.385                 | -13.615     | 40.000         | QUASIPeAK     |
| 2 | 149.101         | 13.012              | 17.900               | 30.912                 | -12.588     | 43.500         | QUASIPeAK     |
| 3 | * 164.678       | 9.055               | 26.200               | 35.255                 | -8.245      | 43.500         | QUASIPeAK     |
| 4 | 217.248         | 10.700              | 23.400               | 34.101                 | -11.899     | 46.000         | QUASIPeAK     |
| 5 | 315.867         | 15.634              | 9.800                | 25.434                 | -20.566     | 46.000         | QUASIPeAK     |
| 6 | 563.603         | 25.643              | 10.800               | 36.443                 | -9.557      | 46.000         | QUASIPeAK     |
| 7 | 960.025         | 27.465              | 12.400               | 39.865                 | -14.135     | 54.000         | QUASIPeAK     |

**Note:**

1. All Readings below 1GHz are Quasi-Peak, above are performed with peak and/or average measurements as necessary.
2. " \* ", means this data is the worst emission level.
3. Measurement Level = Reading Level + Correct Factor

|                              |  |
|------------------------------|--|
| Site : OATS-3                | Time : 2009/07/17 - 17:52                  |
| Limit : FCC_CLASS_B_03M_QP   | Margin : 6                                 |
| EUT : HP Smart Wi-Fi Display | Probe : Site3_CBL6112_3M_0811 - HORIZONTAL |
| Power : AC 120V/60Hz         | Note : Mode 7                              |

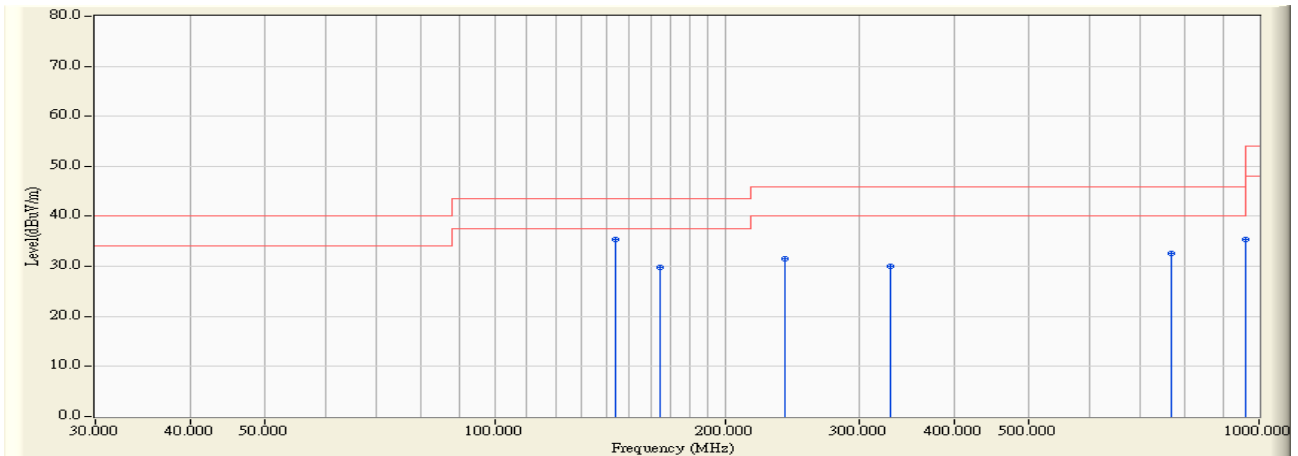

|   |   | Frequency (MHz) | Correct Factor (dB) | Reading Level (dBuV) | Measure Level (dBuV/m) | Margin (dB) | Limit (dBuV/m) | Detector Type |
|---|---|-----------------|---------------------|----------------------|------------------------|-------------|----------------|---------------|
| 1 | * | 144.094         | 13.375              | 22.000               | 35.375                 | -8.125      | 43.500         | QUASIPeAK     |
| 2 |   | 164.684         | 11.912              | 18.000               | 29.912                 | -13.588     | 43.500         | QUASIPeAK     |
| 3 |   | 240.000         | 13.984              | 17.500               | 31.484                 | -14.516     | 46.000         | QUASIPeAK     |
| 4 |   | 329.300         | 16.428              | 13.500               | 29.928                 | -16.072     | 46.000         | QUASIPeAK     |
| 5 |   | 768.010         | 26.353              | 6.300                | 32.653                 | -13.347     | 46.000         | QUASIPeAK     |
| 6 |   | 960.000         | 27.863              | 7.500                | 35.362                 | -10.638     | 46.000         | QUASIPeAK     |

**Note:**

1. All Readings below 1GHz are Quasi-Peak, above are performed with peak and/or average measurements as necessary.
2. " \* ", means this data is the worst emission level.
3. Measurement Level = Reading Level + Correct Factor

|                              |  |
|------------------------------|--|
| Site : OATS-3                | Time : 2009/07/17 - 17:43                |
| Limit : FCC_CLASS_B_03M_QP   | Margin : 6                               |
| EUT : HP Smart Wi-Fi Display | Probe : Site3_CBL6112_3M_0811 - VERTICAL |
| Power : AC 120V/60Hz         | Note : Mode 7                            |

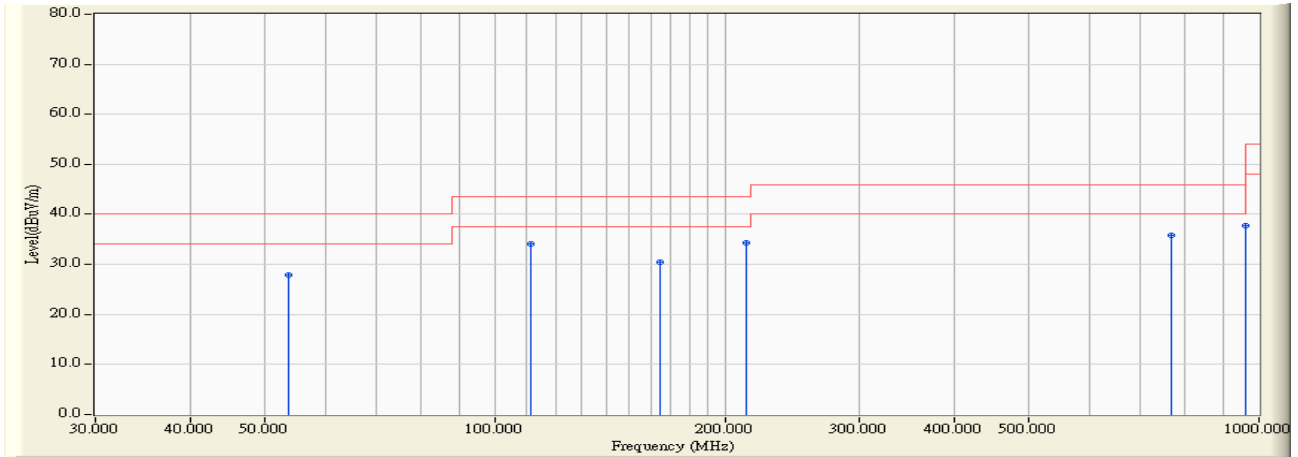

|   |   | Frequency (MHz) | Correct Factor (dB) | Reading Level (dBuV) | Measure Level (dBuV/m) | Margin (dB) | Limit (dBuV/m) | Detector Type |
|---|---|-----------------|---------------------|----------------------|------------------------|-------------|----------------|---------------|
| 1 |   | 53.720          | 7.721               | 20.100               | 27.820                 | -12.180     | 40.000         | QUASIPeAK     |
| 2 |   | 111.180         | 13.365              | 20.700               | 34.065                 | -9.435      | 43.500         | QUASIPeAK     |
| 3 |   | 164.680         | 11.345              | 19.200               | 30.545                 | -12.955     | 43.500         | QUASIPeAK     |
| 4 |   | 212.830         | 12.248              | 22.000               | 34.248                 | -9.252      | 43.500         | QUASIPeAK     |
| 5 |   | 768.612         | 26.988              | 8.900                | 35.888                 | -10.112     | 46.000         | QUASIPeAK     |
| 6 | * | 960.000         | 28.047              | 9.700                | 37.747                 | -8.253      | 46.000         | QUASIPeAK     |

**Note:**

1. All Readings below 1GHz are Quasi-Peak, above are performed with peak and/or average measurements as necessary.
2. " \* ", means this data is the worst emission level.
3. Measurement Level = Reading Level + Correct Factor



|                                 |                                       |
|---------------------------------|---------------------------------------|
| Site : OATS-6                   | Time : 2009/06/30 - 05:36             |
| Limit : FCC_B_(Above_1G)_03M_PK | Margin : 6                            |
| EUT : HP Smart Wi-Fi Display    | Probe : 9120D_1-18G_Horn - HORIZONTAL |
| Power : AC 120V/60Hz            | Note : Mode 1                         |

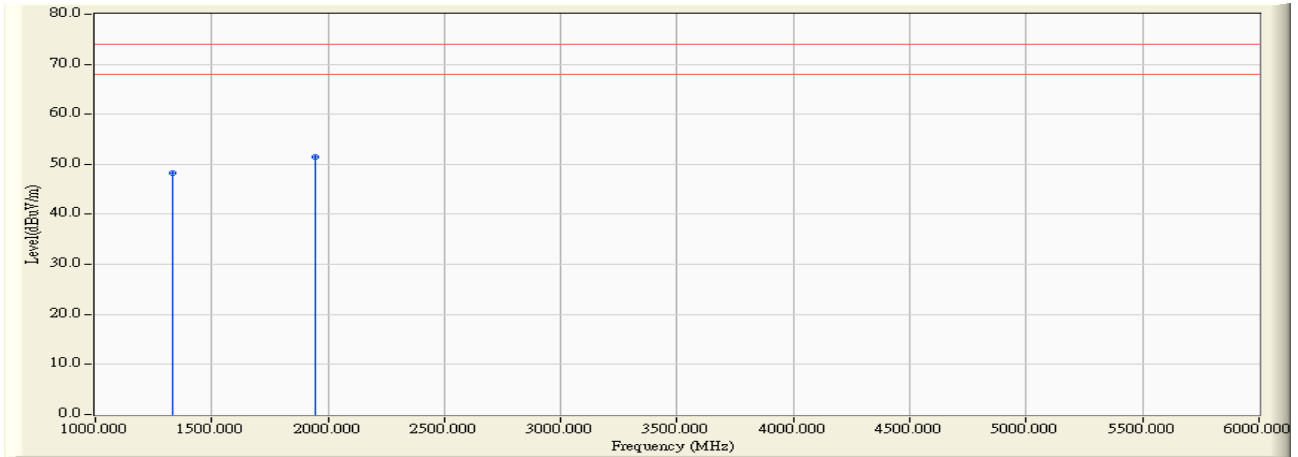

|   |   | Frequency (MHz) | Correct Factor (dB) | Reading Level (dBuV) | Measure Level (dBuV/m) | Margin (dB) | Limit (dBuV/m) | Detector Type |
|---|---|-----------------|---------------------|----------------------|------------------------|-------------|----------------|---------------|
| 1 |   | 1335.000        | -5.459              | 53.640               | 48.181                 | -25.819     | 74.000         | PEAK          |
| 2 | * | 1945.000        | -4.063              | 55.500               | 51.437                 | -22.563     | 74.000         | PEAK          |

**Note:**

1. All Readings below 1GHz are Quasi-Peak, above are performed with peak and/or average measurements as necessary.
2. " \* ", means this data is the worst emission level.
3. Measurement Level = Reading Level + Correct Factor

|                                 |                                     |
|---------------------------------|-------------------------------------|
| Site : OATS-6                   | Time : 2009/06/30 - 05:42           |
| Limit : FCC_B_(Above_1G)_03M_PK | Margin : 6                          |
| EUT : HP Smart Wi-Fi Display    | Probe : 9120D_1-18G_Horn - VERTICAL |
| Power : AC 120V/60Hz            | Note : Mode 1                       |

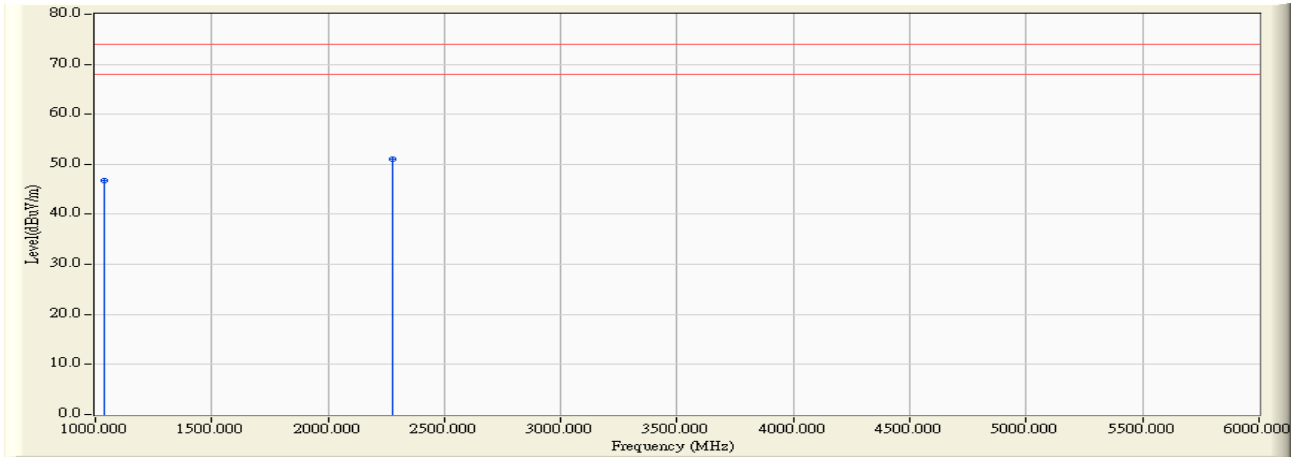

|   |   | Frequency (MHz) | Correct Factor (dB) | Reading Level (dBuV) | Measure Level (dBuV/m) | Margin (dB) | Limit (dBuV/m) | Detector Type |
|---|---|-----------------|---------------------|----------------------|------------------------|-------------|----------------|---------------|
| 1 |   | 1040.000        | -6.512              | 53.250               | 46.738                 | -27.262     | 74.000         | PEAK          |
| 2 | * | 2275.000        | -2.568              | 53.520               | 50.952                 | -23.048     | 74.000         | PEAK          |

**Note:**

1. All Readings below 1GHz are Quasi-Peak, above are performed with peak and/or average measurements as necessary.
2. " \* ", means this data is the worst emission level.
3. Measurement Level = Reading Level + Correct Factor

|                                 |                                       |
|---------------------------------|---------------------------------------|
| Site : OATS-6                   | Time : 2009/06/30 - 05:30             |
| Limit : FCC_B_(Above_1G)_03M_PK | Margin : 6                            |
| EUT : HP Smart Wi-Fi Display    | Probe : 9120D_1-18G_Horn - HORIZONTAL |
| Power : AC 120V/60Hz            | Note : Mode 5                         |

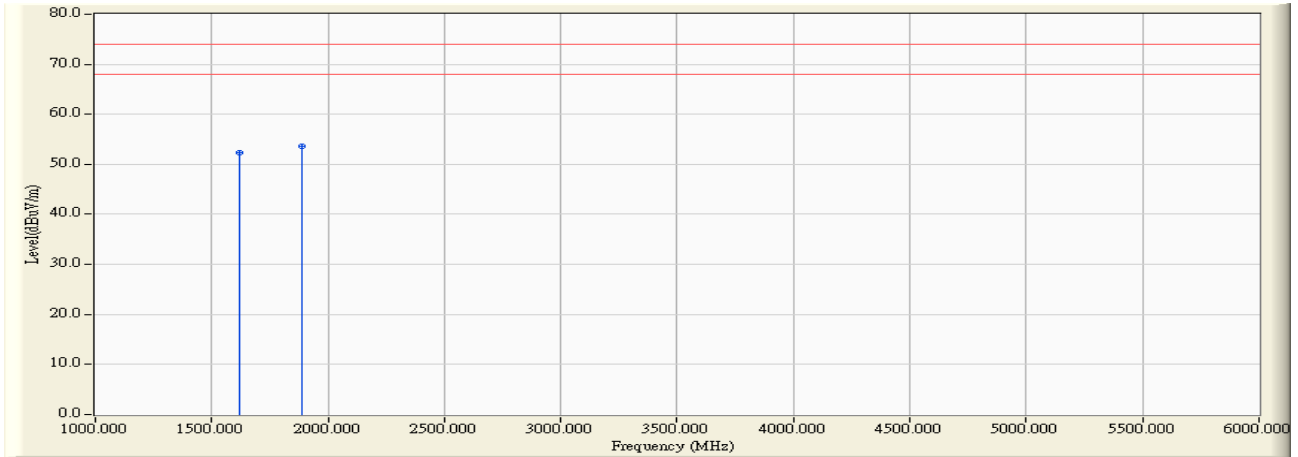

|   |   | Frequency (MHz) | Correct Factor (dB) | Reading Level (dBuV) | Measure Level (dBuV/m) | Margin (dB) | Limit (dBuV/m) | Detector Type |
|---|---|-----------------|---------------------|----------------------|------------------------|-------------|----------------|---------------|
| 1 |   | 1620.000        | -4.961              | 57.390               | 52.429                 | -21.571     | 74.000         | PEAK          |
| 2 | * | 1890.000        | -4.354              | 57.950               | 53.596                 | -20.404     | 74.000         | PEAK          |

**Note:**

1. All Readings below 1GHz are Quasi-Peak, above are performed with peak and/or average measurements as necessary.
2. " \* ", means this data is the worst emission level.
3. Measurement Level = Reading Level + Correct Factor

|                                 |                                     |
|---------------------------------|-------------------------------------|
| Site : OATS-6                   | Time : 2009/06/30 - 05:23           |
| Limit : FCC_B_(Above_1G)_03M_PK | Margin : 6                          |
| EUT : HP Smart Wi-Fi Display    | Probe : 9120D_1-18G_Horn - VERTICAL |
| Power : AC 120V/60Hz            | Note : Mode 5                       |

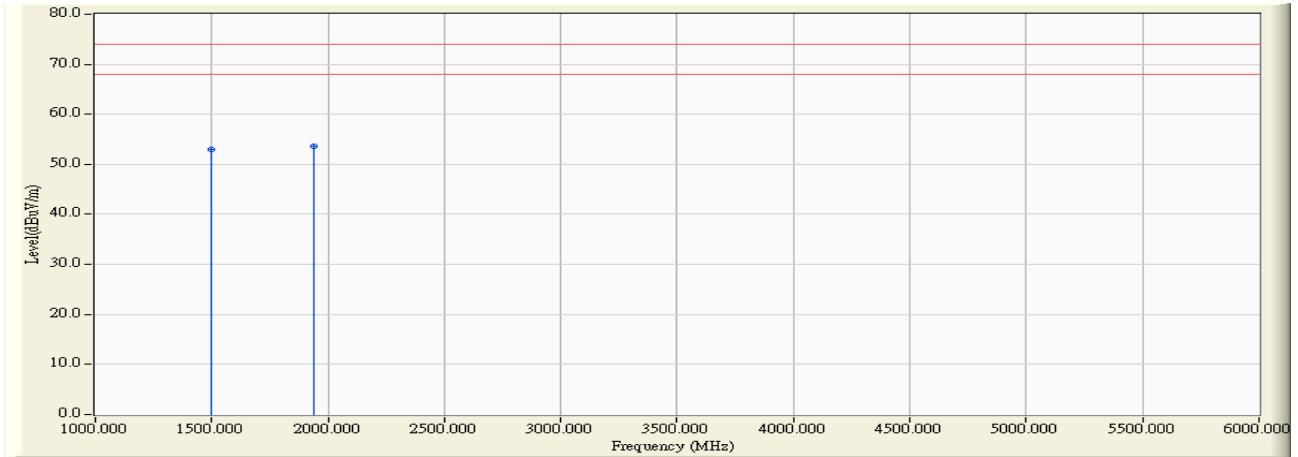

|   |   | Frequency (MHz) | Correct Factor (dB) | Reading Level (dBuV) | Measure Level (dBuV/m) | Margin (dB) | Limit (dBuV/m) | Detector Type |
|---|---|-----------------|---------------------|----------------------|------------------------|-------------|----------------|---------------|
| 1 |   | 1500.000        | -5.049              | 57.940               | 52.891                 | -21.109     | 74.000         | PEAK          |
| 2 | * | 1940.000        | -4.088              | 57.700               | 53.612                 | -20.388     | 74.000         | PEAK          |

**Note:**

1. All Readings below 1GHz are Quasi-Peak, above are performed with peak and/or average measurements as necessary.
2. " \* ", means this data is the worst emission level.
3. Measurement Level = Reading Level + Correct Factor

|                                 |                                       |
|---------------------------------|---------------------------------------|
| Site : OATS-6                   | Time : 2009/07/17 - 15:30             |
| Limit : FCC_B_(Above_1G)_03M_PK | Margin : 6                            |
| EUT : HP Smart Wi-Fi Display    | Probe : 9120D_1-18G_Horn - HORIZONTAL |
| Power : AC 120V/60Hz            | Note : Mode 7                         |

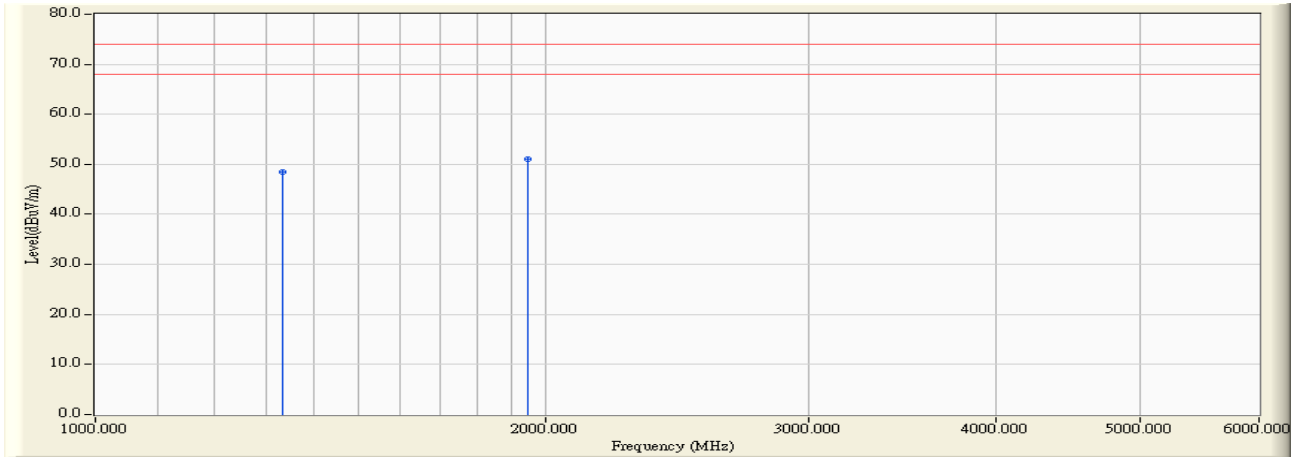

|   |   | Frequency (MHz) | Correct Factor (dB) | Reading Level (dBuV) | Measure Level (dBuV/m) | Margin (dB) | Limit (dBuV/m) | Detector Type |
|---|---|-----------------|---------------------|----------------------|------------------------|-------------|----------------|---------------|
| 1 |   | 1335.000        | -5.459              | 54.030               | 48.571                 | -25.429     | 74.000         | PEAK          |
| 2 | * | 1945.200        | -4.062              | 55.100               | 51.038                 | -22.962     | 74.000         | PEAK          |

**Note:**

1. All Readings below 1GHz are Quasi-Peak, above are performed with peak and/or average measurements as necessary.
2. " \* ", means this data is the worst emission level.
3. Measurement Level = Reading Level + Correct Factor

|                                 |                                     |
|---------------------------------|-------------------------------------|
| Site : OATS-6                   | Time : 2009/07/17 - 15:21           |
| Limit : FCC_B_(Above_1G)_03M_PK | Margin : 6                          |
| EUT : HP Smart Wi-Fi Display    | Probe : 9120D_1-18G_Horn - VERTICAL |
| Power : AC 120V/60Hz            | Note : Mode 7                       |

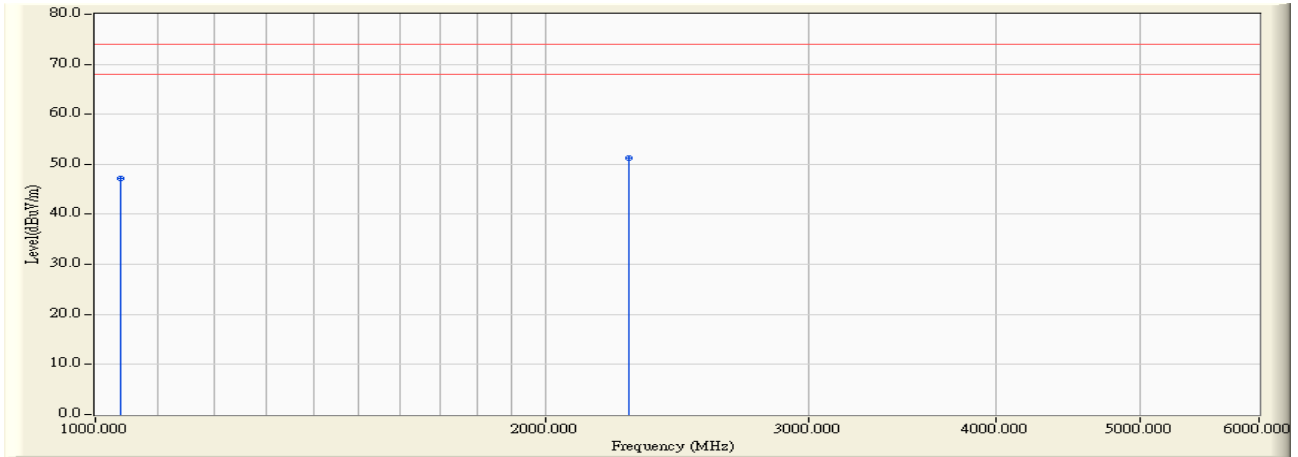

|   |   | Frequency (MHz) | Correct Factor (dB) | Reading Level (dBuV) | Measure Level (dBuV/m) | Margin (dB) | Limit (dBuV/m) | Detector Type |
|---|---|-----------------|---------------------|----------------------|------------------------|-------------|----------------|---------------|
| 1 |   | 1040.300        | -6.511              | 53.600               | 47.089                 | -26.911     | 74.000         | PEAK          |
| 2 | * | 2274.800        | -2.569              | 53.800               | 51.231                 | -22.769     | 74.000         | PEAK          |

**Note:**

1. All Readings below 1GHz are Quasi-Peak, above are performed with peak and/or average measurements as necessary.
2. " \* ", means this data is the worst emission level.
3. Measurement Level = Reading Level + Correct Factor

## 4.6. Test Photograph

Test Mode : Mode 1: Video with Flash + WLAN Mode with DVE Adapter

Description : Front View of Radiated Test



Test Mode : Mode 1: Video with Flash + WLAN Mode with DVE Adapter

Description : Back View of Radiated Test



Test Mode : Mode 1: Video with Flash + WLAN Mode with DVE Adapter

Description : Front View of High Frequency Radiated Test



Test Mode : Mode 5: Link PC Mode

Description : Front View of Radiated Test





Test Mode : Mode 5: Link PC Mode

Description : Back View of Radiated Test



Test Mode : Mode 5: Link PC Mode

Description : Front View of High Frequency Radiated Test



Test Mode : Mode 6: Video with Flash + WLAN Mode (Without Earphone) with DVE Adapter

Description : Front View of Radiated Test



Test Mode : Mode 6: Video with Flash + WLAN Mode (Without Earphone) with DVE Adapter

Description : Back View of Radiated Test



Test Mode : Mode 7: Video with Flash + WLAN Mode with Powertron Adapter

Description : Front View of Radiated Test



Test Mode : Mode 7: Video with Flash + WLAN Mode with Powertron Adapter

Description : Back View of Radiated Test



Test Mode : Mode 7: Video with Flash + WLAN Mode with Powertron Adapter

Description : Front View of High Frequency Radiated Test



5. Attachment

➤ EUT Photograph

(1) EUT Photo



(2) EUT Photo



(3) EUT Photo



(4) EUT Photo



(5) EUT Photo



(6) EUT Photo



(7) EUT Photo



(8) EUT Photo





(9) EUT Photo



(10) EUT Photo



(11) EUT Photo

