

# Amber Helm Development L.C.

92723 Michigan Hwy-152  
Sister Lakes, MI 49047

## EMC Test Report

#GW-1602096FX

Issued 11/30/2016

### Regarding the FCC Part 15, SubPart C testing



### 418 MHz CO Detector Transmitter

FCCID: PPJGW1000TR

Category: 15.231 Transmit Device

Judgments: FCC Part 15.231 – Compliant



NVLAP LAB CODE 200129-0

Prepared for:

*Al Wright*  
*SilentCall Communications Corp*  
*5095 Williams Lake Rd.*  
*Waterford, Mi 48329*

Test Date(s):

4/21/16-8/4/16

Report prepared by:



David J. Miller, NCE

Report reviewed by



Gordon L. Helm, NCE

Data recorded by:

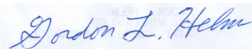

Gordon L. Helm, NCE  
Test Engineer, AHD

**Table of Contents**

Contents

Statements concerning this report.....3

FCC Required user statements:..... 4

FCC Part 18 ISM Devices: ..... 4

FCC Part 15 Class A or B Digital Devices or Peripherals:..... 4

Industry Canada Required user statements: ..... 5

Summary of Results .....7

Changes Made to Achieve Compliance:..... 7

EUT Description .....8

Specifications:..... 8

EUT Block Diagram: ..... 8

EUT Pictures ..... 9

Equipment Test Setup: ..... 11

Support Equipment & Cabling..... 11

Setup Pictures..... 12

Measurement Report .....18

Standards Applied to Test..... 18

Equipment Configuration..... 18

Test Methodology ..... 18

Line Conducted: ..... 18

Radiated: ..... 18

Variance from Test Procedure: ..... 19

Test Data ..... 20

Line Conducted: ..... 20

Radiated Spurious Emissions..... 22

Transmit Measurements ..... 23

Environment..... 28

APPENDIX A .....29

Measurement Procedures ..... 29

Line Conducted ..... 29

Radiated ..... 29

Measurement Facilities & Equipment ..... 31

Test Site: ..... 31

Measurement Equipment Used ..... 31

Cable Loss..... 31

Antenna Factors ..... 33

AHD Accreditation ..... 34

NARTE Seal..... 35

## Statements concerning this report

### NVLAP Accreditation: NVLAP Lab Code 200129-0

The scope of AHD accreditation are the test methods of:

- IEC/CISPR11: Limits and methods of measurement of electrical disturbance characteristics of Industrial, Scientific, and Medical Radio-Frequency Equipment
- IEC/CISPR 22: Limits and methods measurement of radio disturbance characteristics of information technology equipment.
- EN 55032 EMC for Multimedia Devices
- FCC: Method 47 CFR Part 15 Subpart B: Unintentional Radiators.
- FCC: Method 47 CFR Part 15: Subpart C: Intentional Radiators.
- FCC: Method 47 CFR Part 18 – Industrial, Scientific, and Medical Equipment
- AS/NZS 3548: Electromagnetic Interference – Limits and Methods of Measurement of Information Technology Equipment.
- IEC61000-4-2: Electrostatic Discharge Immunity
- IEC61000-4-5: Surge Immunity

### Test Data:

This test report contains data included in the scope of NVLAP accreditation.

### Subcontracted Testing:

This report does not contain data produced under subcontract.

### Test Traceability:

The calibration of all measuring and test equipment and the measured data using this equipment are traceable to the National Institute for Standards and Technology (NIST).

### Limitations on results:

The test results contained in this report relate only to the Item(s) tested. Any electrical or mechanical modification made to the test item subsequent to the test date shall invalidate the data presented in this report. Any electrical or mechanical modification made to the test item subsequent to this test date shall require an evaluation to verify continued compliance.

### Limitations on copying:

This report shall not be reproduced, except in full, without the written approval of AHD.

### Limitations of the report:

This report shall not be used to claim product endorsement by NVLAP, FCC, or any agency of the US Government.

### Statement of Test Results Uncertainty:

Following the guidelines of NAMAS publication NIS81 and NIST Technical Note 1297, the Measurement Uncertainty at a 95% confidence level is determined to be: +/- 2.3 dB

### Retention of Records:

For equipment verified to comply with FCC regulations, the manufacturer is obliged to retain this report with the product records for ten years following the manufacture of the equipment that was tested.

For equipment verified to comply with RSS-210, the manufacturer is obliged to retain this report with the product records for as long as the model is being marketed in Canada.

**FCC Required user statements:****FCC Part 18 ISM Devices:**

1. For all industrial, scientific, medical (ISM) devices, the instruction manual or, if no instruction manual is provided, the product packaging, must provide information that addresses the following: (1) interference potential of the device, (2) maintenance of the system and (3) simple measures that can be taken to correct interference. RF lighting devices must add a statement similar to the following: “This product may cause interference to radio equipment and should not be installed near maritime safety communications equipment, ships at sea or other critical navigation or communications equipment operating between 0.45-30 MHz.” (Section 18.213)

In addition, Part 18 devices that are authorized under the DoC procedure shall also include in the instruction manual, on a separate sheet, or on the packaging the following: (1) identification of the product (e.g. name and model number), (2) a statement similar to “This device complies with Part 18 of the FCC Rules” (Section 18.212), and (3) the name and address of the responsible party (Section 2.909).

2. For products certified using the Declaration of Conformity approach, this FCC conformity LOGO is to be placed on the ISM Device.

**FCC Part 15 Class A or B Digital Devices or Peripherals:**

For products satisfying the FCC Part 15 Class A or Class B requirements the following are to be satisfied:

1. The following statement is required to be labeled on the product or, if the device is too small, in the user’s manual:

*This device complies with part 15 of the FCC Rules. Operation is subject to the following two conditions: (1) This device may not cause harmful interference, and (2) this device must accept any interference received, including interference that may cause undesired operation.*

2. A statement is required to be placed in the User’s Manual shall caution the user that changes or modifications not expressly approved by the party responsible for compliance could void the user’s authority to operate the equipment.

For an FCC Part 15 Class A digital device or peripheral, the user instructions shall include the following or similar statement, placed in a prominent location in the text of the manual:

*Note: This equipment has been tested and found to comply with the limits for a Class A digital device, pursuant to part 15 of the FCC Rules. These limits are designed to provide reasonable protection against*

*harmful interference when the equipment is operated in a commercial environment. This equipment generates, uses, and can radiate radio frequency energy and, if not installed and used in accordance with the instruction manual, may cause harmful interference to radio communications. Operation of this equipment in a residential area is likely to cause harmful interference in which case the user will be required to correct the interference at his own expense.*

*Modifications not expressly approved by the manufacturer could void the user's authority to operated the equipment under FCC rules.*

Additionally, for products satisfying the FCC Part 15 Class B requirements the following are to be satisfied:

1. The User's Manual shall include this or similar statement:

*NOTE: This equipment has been tested and found to comply with the limits for a Class B digital device, pursuant to part 15 of the FCC Rules. These limits are designed to provide reasonable protection against harmful interference in a residential installation. This equipment generates, uses, and can radiate radio frequency energy and, if not installed and used in accordance with the instruction manual, may cause harmful interference to radio communications. However, there is no guarantee that interference will not occur in a particular installation. If this equipment does cause harmful interference to radio or television reception, which can be determined by turning the equipment off and on, the user is encouraged to try to correct the interference by one or more of the following measures:*

- i. Reorient or relocate the receiving antenna.*
- ii. Increase the separation between the equipment and receiver.*
- iii. Connect the equipment into an outlet on a circuit different from that to which the receiver is connected.*
- iv. Consult the dealer or an experienced radio/TV technician for help.*

2. For products certified using the Declaration of Conformity approach,

- a. The FCC conformity LOGO is to be placed on the Class B Digital Device.

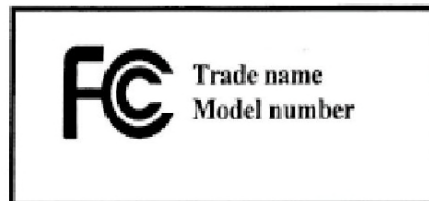

- b. The FCC requires a Compliance Information statement (Declaration of Conformity) to accompany each product to the end user.

## Industry Canada Required user statements:

**Applies to:** [Category II Equipment]

1. For products satisfying the ICES-003, RSS-Gen and RSS-210 Issue 6 requirements the following are to be satisfied:

User manuals for license-exempt LPDs shall contain the following or equivalent statements in a conspicuous position:

*“Operation is subject to the following two conditions: (1) this device may not cause interference, and (2) this device must accept any interference, including interference that may cause undesired operation of the device.”*

If the antenna is detachable (i.e. selectable by the user), see the user manual requirement in Section 7.1.4. The following instructions in the user manual are also required:

*“To reduce potential radio interference to other users, the antenna type and its gain should be so chosen that the equivalent isotropic radiated power (e.i.r.p.) is not more than that permitted for successful communication.”*

The above statements may be placed on the device instead of the manual.

2. User Manual:

User manual shall also contain text declaring compliance to the limits found in this Standard in both English and French.

3. Equipment Labels:

Equipment subject to certification under the applicable RSS's, shall be permanently labeled on each item, or as an inseparable combination. The label must contain the following information for full compliance:

- (a) the certification number, prefixed by the term “IC:”;
- (b) the manufacturer's name, trade name or brand name; and
- (c) a model name or number.

Equipment for which a certificate has been issued is not considered certified if it is not properly labeled.

The information on the Canadian label can be combined with the manufacturer's other labeling requirements.

If the device size is too small to put a label, the label can be included in the user's manual, upon agreement with Industry Canada.

## Summary of Results

1. The device model number GW1000-SS was tested for compliance with FCC Regulations, Part 15, SubPart B. These tests were performed at AHD EMC Laboratory following the procedures outlined in ANSI C63.4.
2. The device tested is compliant to the requirements of FCC Part 15 SubPart C 15.231 for low power periodic transmitter above 70 MHz.
3. The equipment under test was received on 4/21/16 and this test series commenced on 4/21/16.
4. In 120VAC 60Hz operation, the conducted emission level nearest the limit occurred at 403.1 kHz. The signal was measured to be 13.35 dB below the Class B Quasi-Peak limit and 12.05 dB below the Class B Average limit when measuring phase to ground.
5. The spurious radiated emission level nearest the limit occurred at 36 MHz vertically polarized. This signal was measured to be 9.3 dB below the Class B Quasi-peak limit.
6. The device stops transmitting within 3.33 seconds of software diagnostic activation.
7. Transmit fundamental was measured to be 4.21 dB within the 15.231 limit when adjusted for Duty Cycle.
8. Worst case transmit harmonic was found at 1672 MHz. The signal was measured to be 22.02 dB under the class B spurious emissions limit.
9. Worst case peak measurement was found at the fundamental frequency of 418 MHz. The signal was measured to be 6.01 dB under the fundamental peak limit.
10. 20 dB Bandwidth was measured to be 0.24 MHz under the limit at 418 MHz.
11. The radiated receive Local Oscillator was identified at 408 MHz. The worst case local oscillator emission occurred 2926 MHz. This signal was measured to be 15.95 dB below the FCC class B average limit.

## Changes Made to Achieve Compliance:

1. NoneR2 = 820 ohms, X1 = 22 pF, X3 = 4.7 pF

## EUT Description

**Model:** 418 MHz Gateway Transceiver

**Model number:** GW1000-SS

**Serial/ID No:** SilentCall0

**Description:** 418 MHz Transceiver for use with hearing impaired detection devices. In normal operation, the device acts as a receiver only. The transmit function does no polling and is not periodic in any way. The transmitter is only activated in maintenance mode, which activates a diagnostic burst of pulses. Maintenance feature initiates one transmit burst from the RF Carrier Board of 10 packets. Each packet has an 18.75msec of on time. The total burst time is 960msec. Transmission ceases in approximately 3.5 second once enabled by Linxbox.

**Antenna:** Linx Technologies ANT-418-PW-RA 2 dBi Peak Gain

**PCBs:** 418 MHz Carrier Board 40-325-001-01  
Linx "Ethernet Gateway"

## Specifications:

**Input Power:** 5VDC 1 Amp mini USB Adaptor AC DYS605-050100-15C28C

## Input / Outputs Signals:

418 MHz signal,  
RJ45 Ethernet,  
USB "Future Expansion" (Covered with label, not accessible to end user)

## EUT Block Diagram:

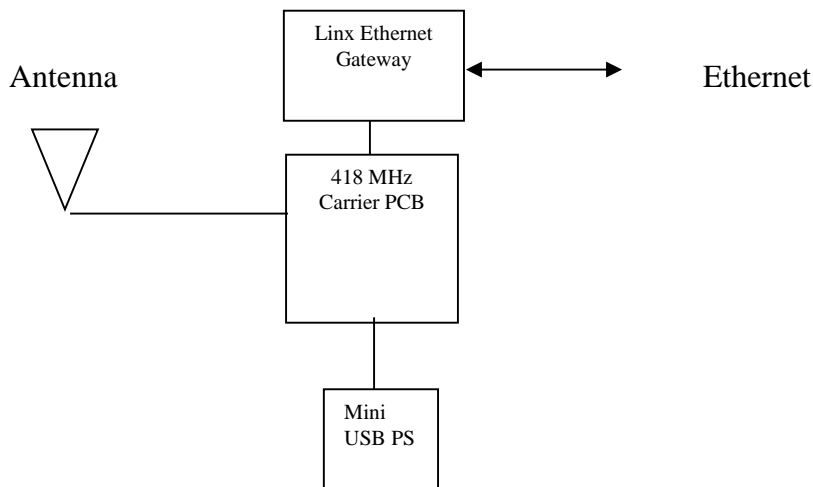



## EUT Pictures

- Exterior View Front Page 9
- Exterior View Rear View Page 9
- Ethernet PCB Front Page 11
- Ethernet PCB Rear Page 11
- Carrier PCB Front Page 11
- Carrier PCB Rear Page 11

### Exterior View Front



### Exterior View Rear View



### Ethernet PCB Front



### Ethernet PCB Rear



### Carrier PCB Front



### Carrier PCB Rear



**Equipment Test Setup:**

**Support Equipment & Cabling**

Setup Diagram Legend	Description	Model	Serial No. / Part No.	EMC Consideration
A	418 MHz Gateway Transceiver	GW1000-SS	SilentCall9	418 MHz Transceiver
B	5V 1 AMP Mini USB Power Supply	AC	DYS605-050100-15C28C	DC Power Supply, 1M Cable
C	Ethernet Cable			3M Unshielded, connected with router outside of test field
D	Antenna	Linx Quarter Wave	ANT-418-PW-RA	2dBi max gain

**Block Diagram**

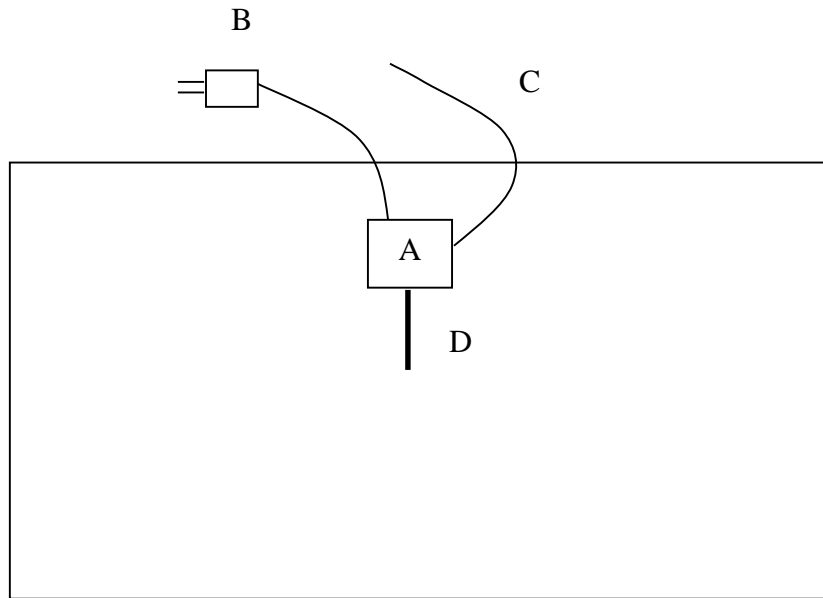

## Setup Pictures

- Radiated Prescreen Setup Page 12
- Conducted Setup Front View Page 13
- Conducted Setup Rear View Page 13
- Spurious Setup Front View Page 14
- Spurious Setup Rear View Page 14
- Transmit Setup – Flat Orientation Page 15
- Transmit Setup –Side Orientation Page 15
- Transmit Setup – End Orientation Page 16
- Harmonics Test Above 1 GHz Flat Orientation Page 16
- Harmonics Test Above 1 GHz Side Orientation Page 17
- Harmonics Test Above 1 GHz End Orientation Page 17

### Radiated Prescreen Setup



### Conducted Setup Front View



### Conducted Setup Rear View



### Spurious Front View



### Spurious Rear View

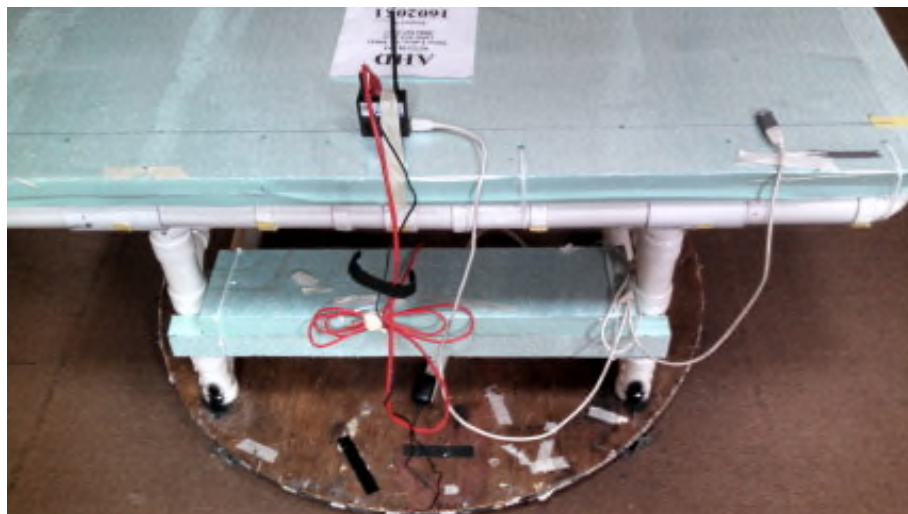

### Transmit Setup – Flat Orientation

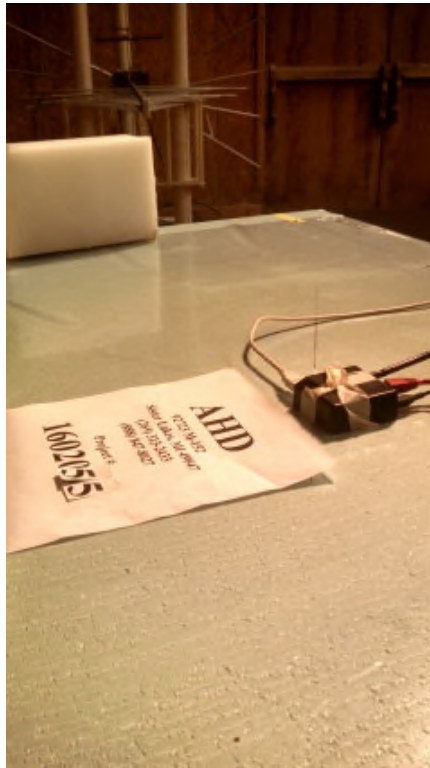

### Transmit Setup – Side Orientation



### Transmit Setup – End Orientation



### Harmonics Test with Horn Antenna for over 1 GHz – Flat Orientation





## Harmonics Test with Horn Antenna for over 1 GHz – Side Orientation

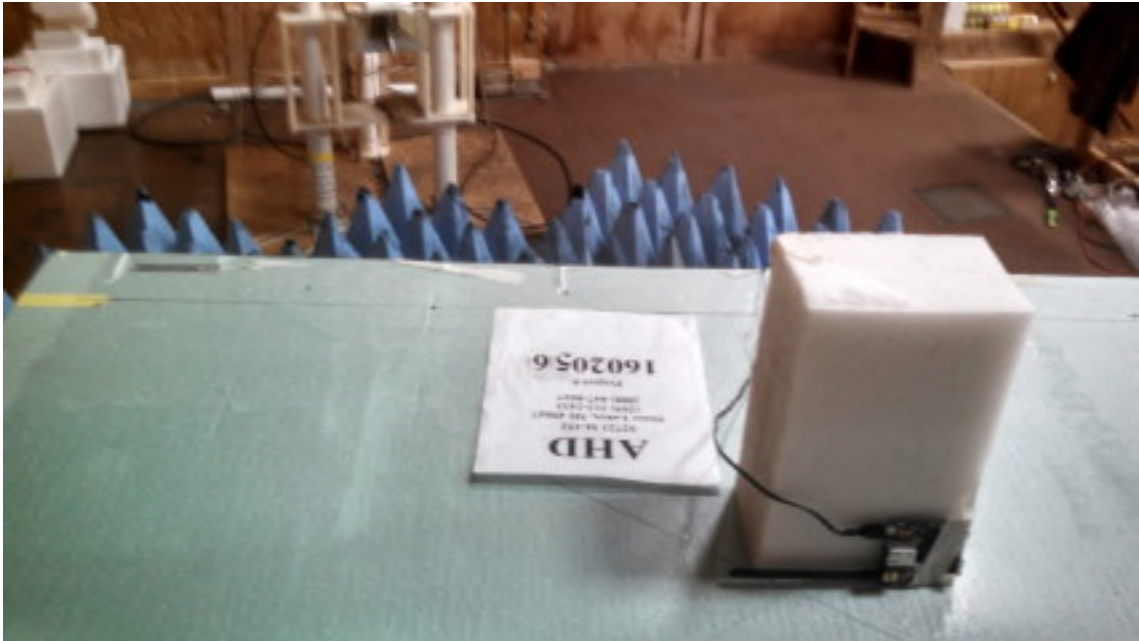

## Harmonics Test with Horn Antenna for over 1 GHz – End Orientation



## Measurement Report

### Standards Applied to Test

ANSI C63.4 – Radio Noise Emissions 2014  
ANSI C63.10 – Intentional Radiators 2013  
CFR47 FCC Part 15, SubPart B/C  
AHD/SEI test procedures TP0101LC, TP0102RA  
EN55032:2012 EMC for Multimedia Devices  
EN61000-6-3 Generic 2007.2

### Equipment Configuration

For the testing, the placement of the EUT and the support equipment was selected to –

- Be a representation of a configuration typical of user installation, and
- Comply with the minimum system configuration of ANSI C63.4.

### Test Methodology

#### Line Conducted:

Line Conducted test procedures are described in Appendix A.

#### Radiated:

Spurious radiated testing was performed at a 3meter open field test site, and completed according to the procedures in FCC 15, SubPart B with supporting instructions from ANSI C63.4. Please reference Appendix A for further details on Test Methodology.

Note that distances less than 3 meters (i.e. 1 and 0.1 meter) may be used if signals are not detectable at specified distances, and distances compensated for within the tabulated measurements.

A scan of the EUT was made in a shielded room to study the emission profile of this EUT. This scan indicated low level spurious emissions from the unit.

The suspect signals recorded in the shielded room prescan were then measured at the 3-meter open area test site.

The EUT was scanned for radiated energy up to 4.18 GHz to meet FCC 15.33 requirements.

The EUT was tested in three orientations with horizontal and vertical antennal polarities to determine maximum signal. After determining that the maximized orientation as End Vertical, all measurements were recorded in this orientation.

The EUT under test was placed per ANSI C63.4

The EUT was exercised as follows:

1. Device was powered and activated with external power supply.
2. Evidence of operation was signal presence operation.

The cables were manipulated to produce the highest signal level relative to the limit.

The pictures, in the preceding pages, show the position of the equipment and cabling that produced the maximum signal level.

**Variance from Test Procedure:**

None

## Test Data

### Line Conducted:

### NEUTRAL to Ground Measurement. Class B Plot of Peak Values

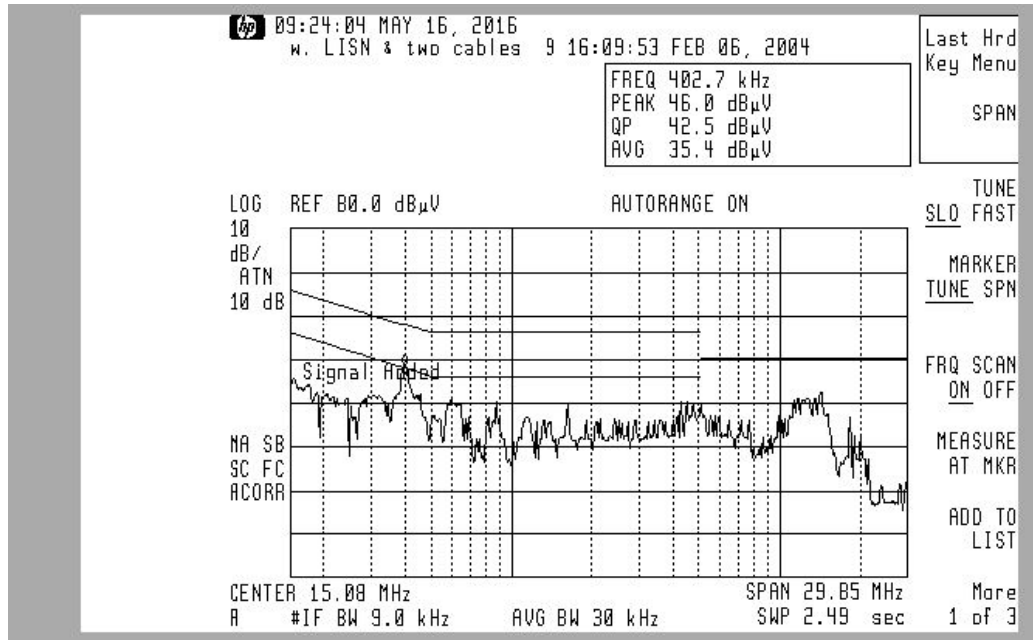

### NEUTRAL to Ground Conducted Class B Tabulated Measurements

Frequency MHz	dBuV Reading		FCC / EN55032 dBuV Class B Limit		dB Margin	
	QP	Avg	QP	Avg	QP	Avg
0.40	42.50	35.40	57.85	47.85	15.35	12.45
0.60	30.00	24.00	56.00	46.00	26.00	22.00
0.88	27.00	22.00	56.00	46.00	29.00	24.00
1.60	28.00	22.00	56.00	46.00	28.00	24.00
4.40	27.00	20.00	60.00	50.00	33.00	30.00
12.00	32.00	18.00	60.00	50.00	28.00	32.00

**PHASE to Ground Measurement.  
Class B Plot of Peak Values**

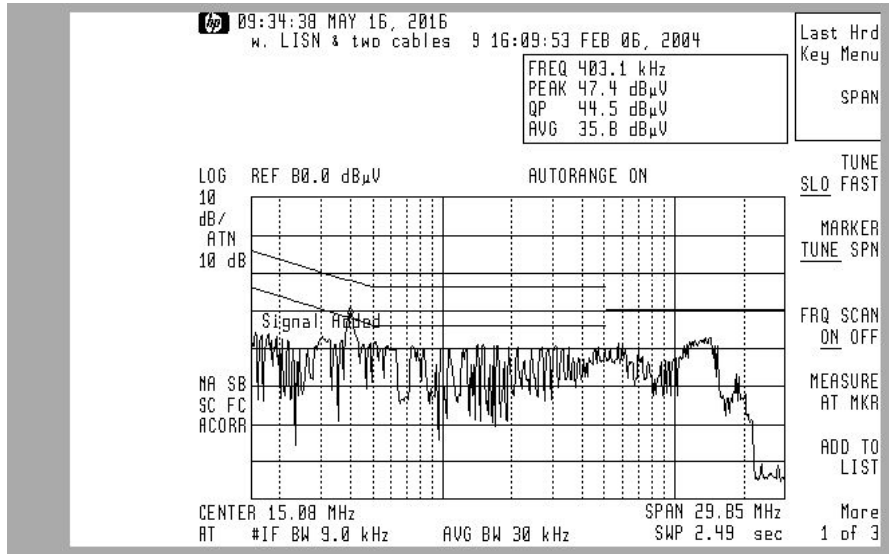

**PHASE to Ground Conducted  
Class B Tabulated Measurements**

Frequency MHz	dBuV Reading		FCC / EN55022 dBuV Class A Limit		dB Margin	
	QP	Avg	QP	Avg	QP	Avg
0.40	44.50	35.80	57.85	47.85	13.35	12.05
0.73	32.00	21.00	56.00	46.00	24.00	25.00
1.40	31.00	19.00	56.00	46.00	25.00	27.00
5.90	30.00	19.00	60.00	50.00	30.00	31.00
14.00	37.00	30.00	60.00	50.00	23.00	20.00
17.00	30.00	24.00	60.00	50.00	30.00	26.00

## Radiated Spurious Emissions

### Vertically Polarized Class B Tabulated Spurious Quasi-Peak Measurements at 3 Meters

Frequency	Corrected Quasipeak Measurement	Turntable Azimuth	Antenna Height	FCC Class B Limit	Margin Class B
MHz	dBuV/m	deg	Mtr	dBuV/m	dBuV/m
<b>36.00</b>	<b>30.70</b>	<b>190</b>	<b>1.0</b>	<b>40.00</b>	<b>9.30</b>
<b>169.00</b>	<b>13.40</b>	<b>190</b>	<b>1.0</b>	<b>43.50</b>	<b>30.10</b>
<b>258.00</b>	<b>16.60</b>	<b>170</b>	<b>1.0</b>	<b>46.00</b>	<b>29.40</b>
<b>357.00</b>	<b>15.10</b>	<b>180</b>	<b>1.0</b>	<b>46.00</b>	<b>30.90</b>
<b>384.00</b>	<b>27.10</b>	<b>180</b>	<b>1.0</b>	<b>46.00</b>	<b>18.90</b>
<b>450.00</b>	<b>34.10</b>	<b>190</b>	<b>1.0</b>	<b>46.00</b>	<b>11.90</b>

### Horizontally Polarized Class B Tabulated Quasi-Peak Measurements at 3 Meters

Frequency	Corrected Quasipeak Measurement	Turntable Azimuth	Antenna Height	FCC Class B Limit	Margin
MHz	dBuV/m	deg	Mtr	dBuV/m	dBuV/m
<b>36.00</b>	<b>23.00</b>	<b>330</b>	<b>1.6</b>	<b>40.00</b>	<b>17.00</b>
<b>170.00</b>	<b>10.20</b>	<b>180</b>	<b>1.0</b>	<b>43.50</b>	<b>33.30</b>
<b>250.00</b>	<b>25.50</b>	<b>180</b>	<b>1.8</b>	<b>46.00</b>	<b>20.50</b>
<b>300.00</b>	<b>28.30</b>	<b>300</b>	<b>1.7</b>	<b>46.00</b>	<b>17.70</b>
<b>350.00</b>	<b>26.60</b>	<b>240</b>	<b>1.0</b>	<b>46.00</b>	<b>19.40</b>
<b>450.00</b>	<b>34.70</b>	<b>160</b>	<b>1.5</b>	<b>46.00</b>	<b>11.30</b>

### Transmit Measurements

#### Duty Cycle Calculation

#### Packet Spacing

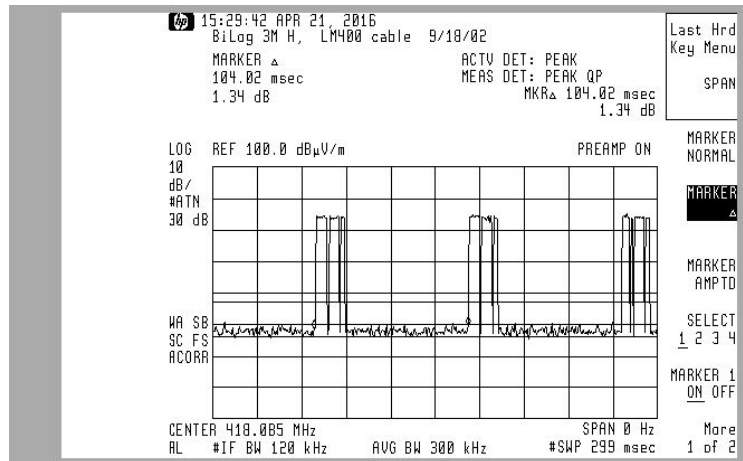

#### Single Pulse Train Plot (8 pulses)

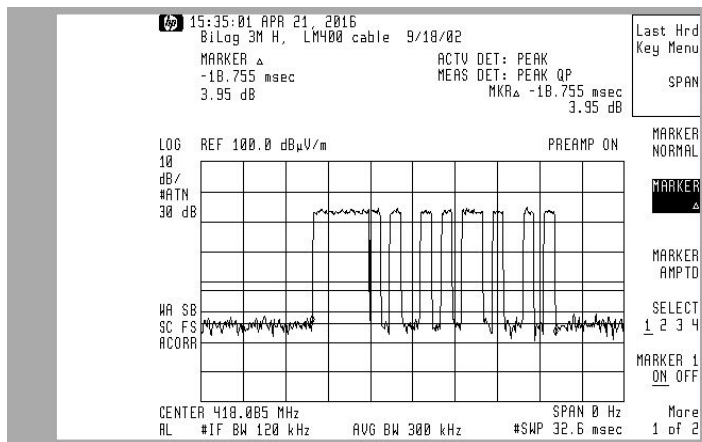

#### Narrow Gap Plot

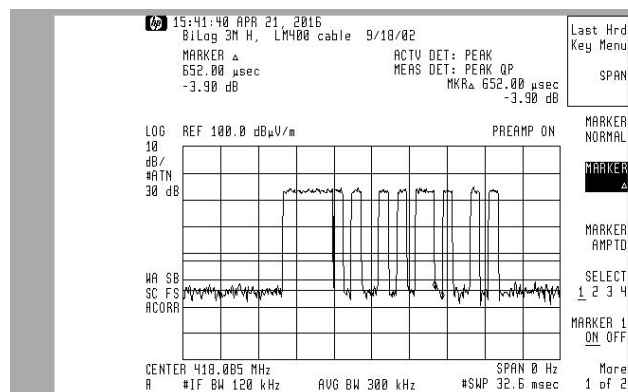

### Wide Gap Plot

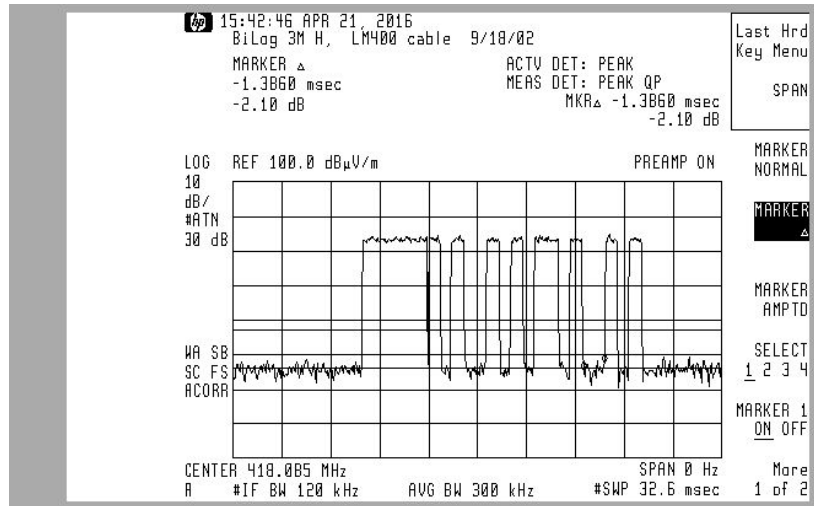

### Tabulated Duty Cycle Calculation

Full Packet	Narrow Gap Width	Narrow Gaps per packet	Wide Gap Width	Wide Gaps per packet	On Time = (Packet Width) - (Narrow Gaps) - (Wide Gaps)	Duty Cycle	Duty Cycle
mSec	mSec		mSec		mSec		dBuV
<b>18.75</b>	<b>0.65</b>	<b>5.00</b>	<b>1.39</b>	<b>2.00</b>	<b>12.71</b>	<b>0.13</b>	<b>-17.92</b>

### 5 Second Deactivation

### Plot of Device Deactivation after Software Activation

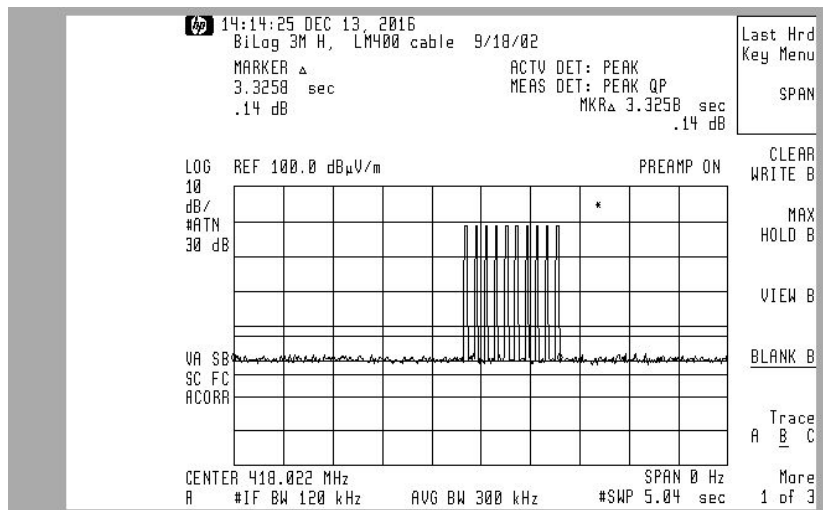



*Transmit Fundamental*

**Transmit Fundamental Signal Plot**

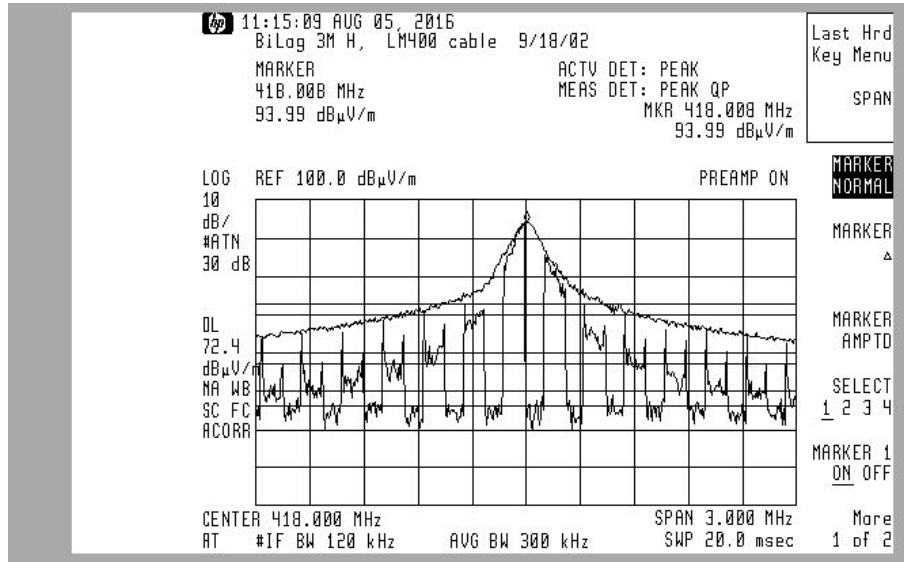

**Transmit Fundamental Limit Calculation**

Frequency Point 1	Frequency Point 2	Limit point 1	Limit point 2	Slope	Intercept	Test Frequency	Limit
MHz	MHz	uV/M	uV/M	uV/M/MHz	uV/M	MHz	uV/M
<b>470.00</b>	<b>260.00</b>	<b>12500.00</b>	<b>3750.00</b>	<b>41.67</b>	<b>-7.08E+03</b>	<b>418.00</b>	<b>1.03E+04</b>

Note: Limit is equivalent to 80.03 dBuV/M

**Tabulated Transmit Fundamental Measurement Data**

Frequency	Maximum Measurement	Duty Cycle Adjustment	Average Measurement	Average Measurement	15.231 Limit @ 418 MHz	Margin	Margin
MHz	dBuV	dB	dBuV/M	uV/M	uV/M	uV	dB
<b>418.00</b>	<b>93.99</b>	<b>-17.92</b>	<b>76.07</b>	<b>6362.76</b>	<b>10333.33</b>	<b>3970.57</b>	<b>4.21</b>

Note: Worst Case Orientation was determined to Flat Horizontally Polarized

**Transmit Spurious / Harmonic Limit Calculation**

Frequency Point 1	Frequency Point 2	Limit point 1	Limit point 2	Slope	Intercept	Test Frequency	Limit
MHz	MHz	uV/M	uV/M	uV/M/MHz	uV/M	MHz	uV/M
<b>470.00</b>	<b>260.00</b>	<b>1250.00</b>	<b>375.00</b>	<b>4.17</b>	<b>-7.08E+02</b>	<b>418.00</b>	<b>1.03E+03</b>

Note: Limit is equivalent to 60.03 dBuV/M. For convenience, Spurious limits used in actual measurements.

**Tabulated Transmit Harmonic Signals**

Frequency	3M Peak Measurement	17.92 dB Duty Cycle Adjusted Measurement	Limit	Margin
MHz	dBuV	dBuV	dBuV/M	dB
<b>836.00</b>	<b>43.55</b>	<b>25.63</b>	<b>54.00</b>	<b>28.37</b>
<b>1250.00</b>	<b>37.89</b>	<b>19.97</b>	<b>54.00</b>	<b>34.03</b>
<b>#1672.00</b>	<b>49.90</b>	<b>31.98</b>	<b>54.00</b>	<b>22.02</b>
<b>2090.00</b>	<b>47.30</b>	<b>29.38</b>	<b>54.00</b>	<b>24.62</b>
<b>2508.00</b>	<b>35.30</b>	<b>17.38</b>	<b>54.00</b>	<b>36.62</b>
<b>2926.00</b>	<b>38.05</b>	<b>20.13</b>	<b>54.00</b>	<b>33.87</b>
<b>3344.00</b>	<b>36.79</b>	<b>18.87</b>	<b>54.00</b>	<b>35.13</b>
<b>#3762.00</b>	<b>35.46</b>	<b>17.54</b>	<b>54.00</b>	<b>36.46</b>
<b>#4180.00</b>	<b>13.00</b>	<b>-4.92</b>	<b>54.00</b>	<b>58.92</b>

# Restricted Band Signal (same limits apply)

**Tabulated Peak Data**

Frequency	3M Peak Measurement	Limit	Margin
MHz	dBuV	dB	dBuV/M
<b>418.00</b>	<b>93.99</b>	<b>100.00</b>	<b>6.01</b>
<b>836.00</b>	<b>43.55</b>	<b>74.00</b>	<b>30.45</b>
<b>1250.00</b>	<b>37.89</b>	<b>74.00</b>	<b>36.11</b>
<b>#1672.00</b>	<b>49.90</b>	<b>74.00</b>	<b>24.10</b>
<b>2090.00</b>	<b>47.30</b>	<b>74.00</b>	<b>26.70</b>
<b>2508.00</b>	<b>35.30</b>	<b>74.00</b>	<b>38.70</b>
<b>2926.00</b>	<b>38.05</b>	<b>74.00</b>	<b>35.95</b>
<b>3344.00</b>	<b>36.79</b>	<b>74.00</b>	<b>37.21</b>
<b>#3762.00</b>	<b>35.46</b>	<b>74.00</b>	<b>38.54</b>
<b>#4180.00</b>	<b>13.00</b>	<b>74.00</b>	<b>61.00</b>

# Restricted Band Signal (same limits apply)

**Plot of 20 dB BW**

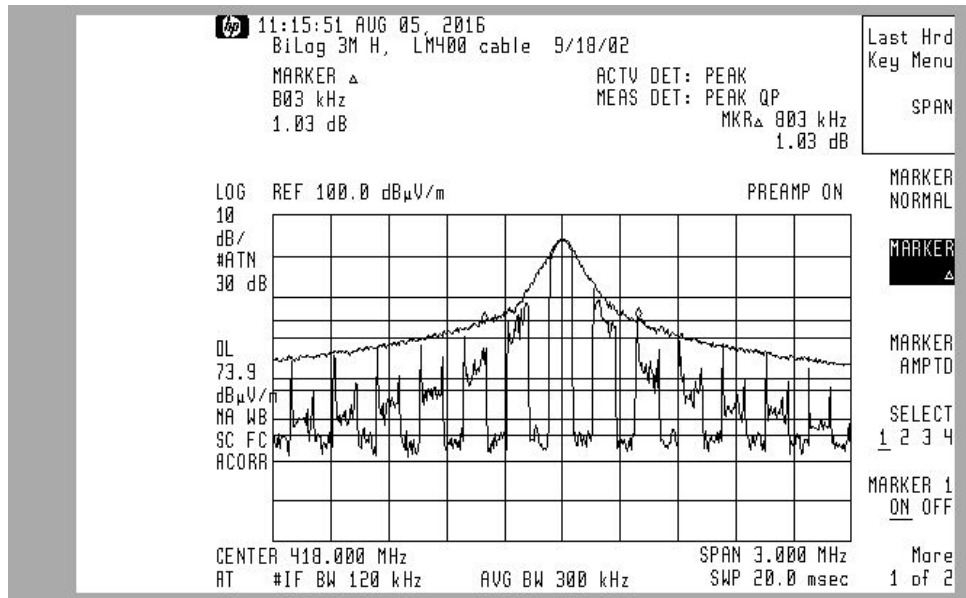

**Tabulated 20 dB BW Measurement**

Frequency	Measurement	Limit	Margin
MHz	MHz	MHz	dBuV/M
<b>418.00</b>	<b>0.80</b>	<b>1.05</b>	<b>0.24</b>

### Local Oscillator Plot

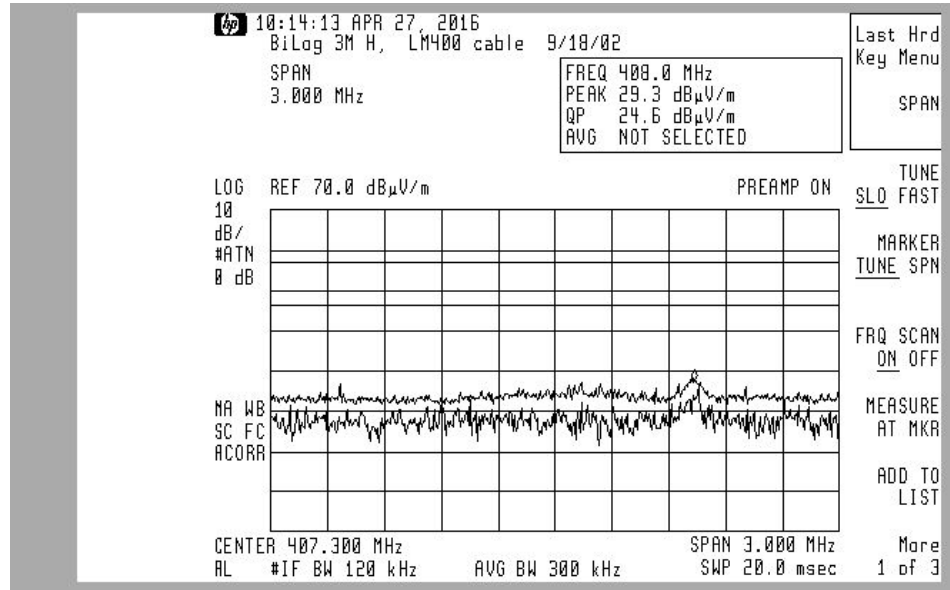

### Tabulated Local Oscillator Fundamental and Harmonics

Frequency	3M Peak Measurement	Limit	Margin
MHz	dBuV	dBuV/M	dB
<b>408.00</b>	<b>29.30</b>	<b>46.00</b>	<b>16.70</b>
<b>813.00</b>	<b>28.10</b>	<b>46.00</b>	<b>17.90</b>
<b>1222.00</b>	<b>30.09</b>	<b>54.00</b>	<b>23.91</b>
<b>1629.00</b>	<b>29.15</b>	<b>54.00</b>	<b>24.85</b>
<b>2037.00</b>	<b>30.85</b>	<b>54.00</b>	<b>23.15</b>
<b>2926.00</b>	<b>38.05</b>	<b>54.00</b>	<b>15.95</b>
<b>3344.00</b>	<b>36.79</b>	<b>54.00</b>	<b>17.21</b>
<b>3762.00</b>	<b>35.46</b>	<b>54.00</b>	<b>18.54</b>
<b>4180.00</b>	<b>13.00</b>	<b>54.00</b>	<b>41.00</b>

### Environment

The test was performed with the equipment under test, and measurement equipment inside the all-weather enclosure. Ambient temperature was 80 deg F, the relative humidity 40%.

## APPENDIX A

### Measurement Procedures

#### Line Conducted

The system was placed upon a 1 x 1.5 meter non-metallic table 80cm from the ground floor and 40cm from the vertical conducting plane in the prescribed setup per ANSI C63.4. This table is housed in a shielded enclosure to prevent the detection of unwanted ambients.

The EUT, or host unit if applicable, was connected to the LISN being monitored by the EMI Receiver. The remaining support devices requiring mains power were connected to a second LISN.

The EUT was continuously exercised by methods supplied by the manufacturer.

While monitoring the display of the EMI Receiver, via remote video monitor, the cables were manipulated to determine a position that maximized the emissions being observed. Once the highest amplitude relative to the limit was determined for the Phase current carrying line the procedure was repeated for the Neutral current carrying line.

The configuration that created an emission closest to the limit was used during the course of taking final measurements. Pictures of this final configuration are recorded in this report.

The principal settings of the EMI Receiver for line conducted testing include:

Bandwidth = 9kHz

Detector Function: scanning and signal search = Peak Detection Mode  
measurements = Quasi Peak Detection and Average Detection

The cable losses of the coax used in line conducted testing are charted in this appendix.

#### Radiated

The system was placed upon a 1 x 1.5 meter non-metallic table 80cm from the open field site ground plane in the prescribed setup per ANSI C63.4, Figure 9(c).

The table sits upon a remote controlled turntable. The receiving antenna, located at the appropriate standards distance of 3 or 10 meters from the table center, is also remote controlled.

The EUT was continuously exercised by software supplied by the manufacturer.

Preliminary tests were done at the 3 meter open field test site. The final tests are done at the appropriate standards distance of 3 or 10 meters. The "Biconical/Log Periodic" broadband antenna connected to an EMI Receiver, meeting CISPR 16, is used throughout the testing.

Note that distances less than 3 meters (i.e. 1 and 0.1 meter) may be used if signals are not detectable at specified distances, and distances compensated for within the tabulated measurements.

During the preliminary scans and while monitoring the display of the EMI Receiver, the turntable was rotated 360 degrees and the receiving antenna height varied from 1 to 4 meters to search out the highest emissions. At the significant emissions, the cables were manipulated to determine a position that maximized the emissions being observed. Once the cable position was determined that presented the highest amplitude relative to the limit for Vertical polarized emissions the procedure was repeated for the Horizontal polarization.

The configuration that created an emission closest to the limit was used during the course of taking final measurements. Pictures of this final configuration are recorded in this report.

The principal settings of the EMI Receiver for radiated signal testing between 30 MHz and 1 GHz include:

Bandwidth: 120kHz  
 Detector Function: scanning and signal search = Peak Mode  
 measurements = Quasi Peak Mode.  
 Search Range: 30MHz to 1000MHz or to 2GHz as appropriate

The principal settings of the EMI Receiver for radiated testing above 1 GHz include:

Bandwidth: 1 MHz  
 Detector Function: scanning and signal search = Peak Mode  
 Duty Cycle Compensated Measurements = Peak Mode  
 Direct Signal Measurements = Average Mode.  
 Search Range: Above 1000MHz as required

The cable loss of the coax used in radiated scanning is charted in this appendix.  
 The antenna factors, for the test distance used, are charted in this appendix.

The resultant Field Strength (FS) is a summation in decibels (dB) of the Indicated Receiver Level (RF), the Antenna Correction Factor (AF), and the Cable Loss Factor (CF). If a PreAmplifier (PA) is used, its gain (dB) is subtracted from the above sum.

Formula 1:  $FS(\text{dBuV/m}) = RF(\text{dBuV}) + AF(\text{dB/m}) + CF(\text{dB}) - PA(\text{dB})$

To convert the Field Strength dBuV/m term to uV/m, the dBuV/m is first divided by 20. The Base 10 AntiLog is taken of this quotient. The result is the Field Strength value in uV/m terms.

Formula 2:  $FS(\text{uV/m}) = \text{AntiLog}[(FS(\text{dBuV/m}))/20]$

## Measurement Facilities & Equipment

### Test Site:

The AHD test facility is centered on 9 acres of rural property near Sister Lakes, Michigan. The mailing address is 92723 Michigan Hwy152, Sister Lakes, 49047. This test facility is NVLAP accredited (LabCode 200129-0). It has been fully described in a report filed with the FCC (No.90413) and Industry Canada (file:IC3161).

### Measurement Equipment Used

Equipment	Model	S/N	Last Cal Date	Calibration Interval
HP EMI Receiver system	HP 8546A			
RF Filter Section	HP-85460A	3448A00267	22 Jan-15	24 months
RF Receiver Section	HP-85462A	3807A00437	22 Jan-15	24 months
EMCO Double Ridged Horn	3115	2788	28-Jul-16	12 months
EMCO BiconiLog Antenna	3142	1169	25- Apr-16	12 months
Solar LISN	8012-50-R-24-BNC	962138	9 Mar-16	12 months
(3-m) LMR-400 Ultra Flex	LMR400	C090804	1-Jul-16	6 months
(3-m) CS-3227 RG8	CS-3227	C060914	1-Jul-16	6 months
(10-m) Amelco 50ohm Coax	RG213U	9903-10ab	1-Jul-16	6 months
(LCI) Double shielded 50ohm Coax	RG58/U	920809	1-Jul-16	12 months
Keytek Surge	711B	8511854	1-Jul-16	12 months
Schaffner ESD	NSG432	01027	1-Jul-16	12 months
Schaffner EFT	NSG600/641	0113	1-Jul-16	12 months
Compliance Design Biconical Antenna	B100	016460	6-August-15	36 months
Compliance Design Biconical Antenna	B200	A10102	14-August-15	36 months
Compliance Design Biconical Antenna	B300	A10103	6-August-15	36 months

### Cable Loss

Line Conducted 150KHz through 30MHz, Coax #920809  
Last Calibration date: 1-Jul-16

FCC Part 15 Testing for Gateway Transceiver

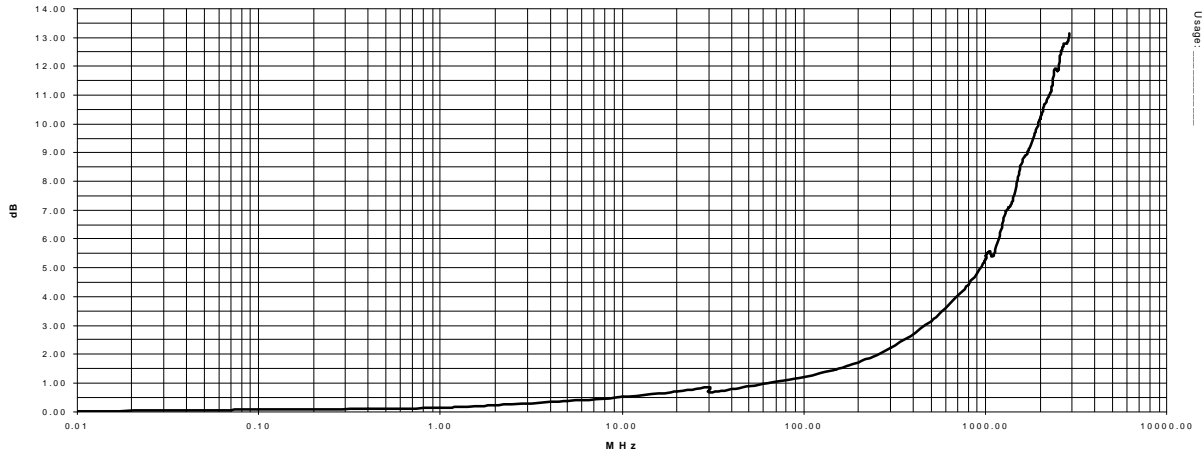

Radiated at 3 meters; 30MHz through 3000MHz, Coax #C090804  
Last Calibration date: 1-Jul-16

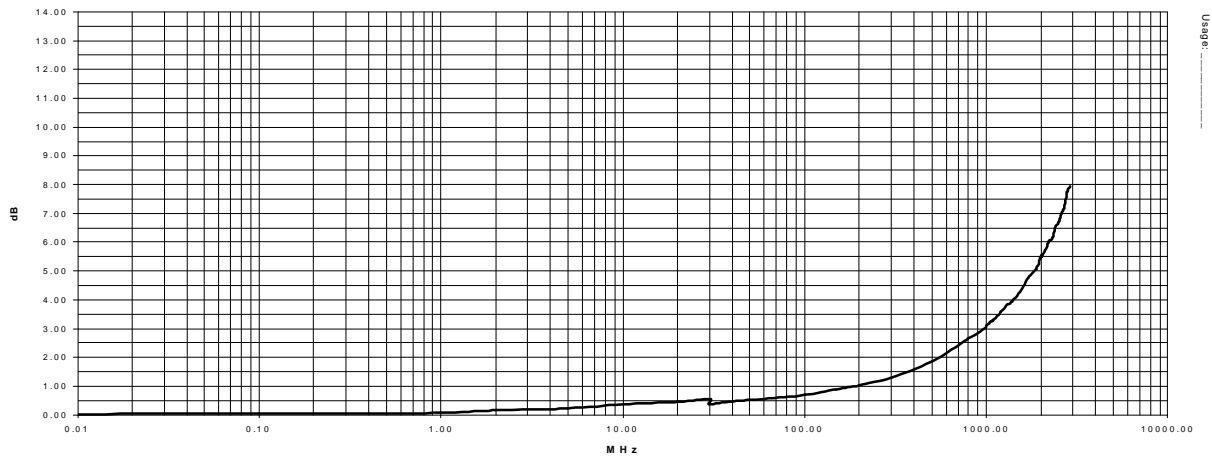



## Antenna Factors

EMCO Model 3142 Antenna  
Last Calibration Date; 25- Apr-16  
3 Meter Distance Factors

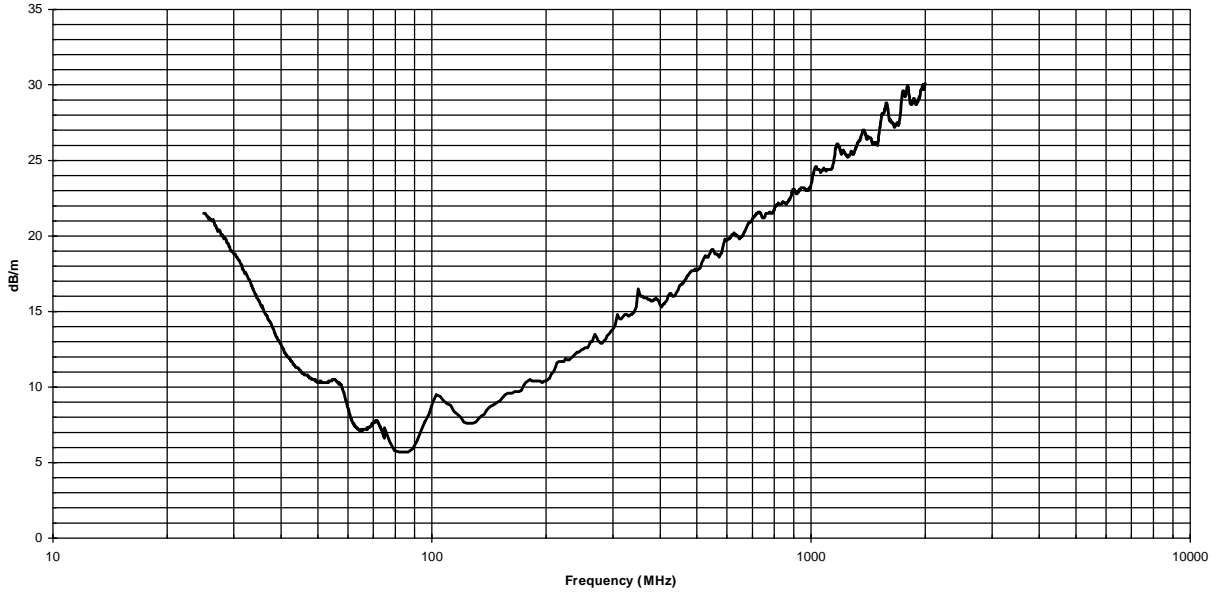

### 10 Meter Distance Factors

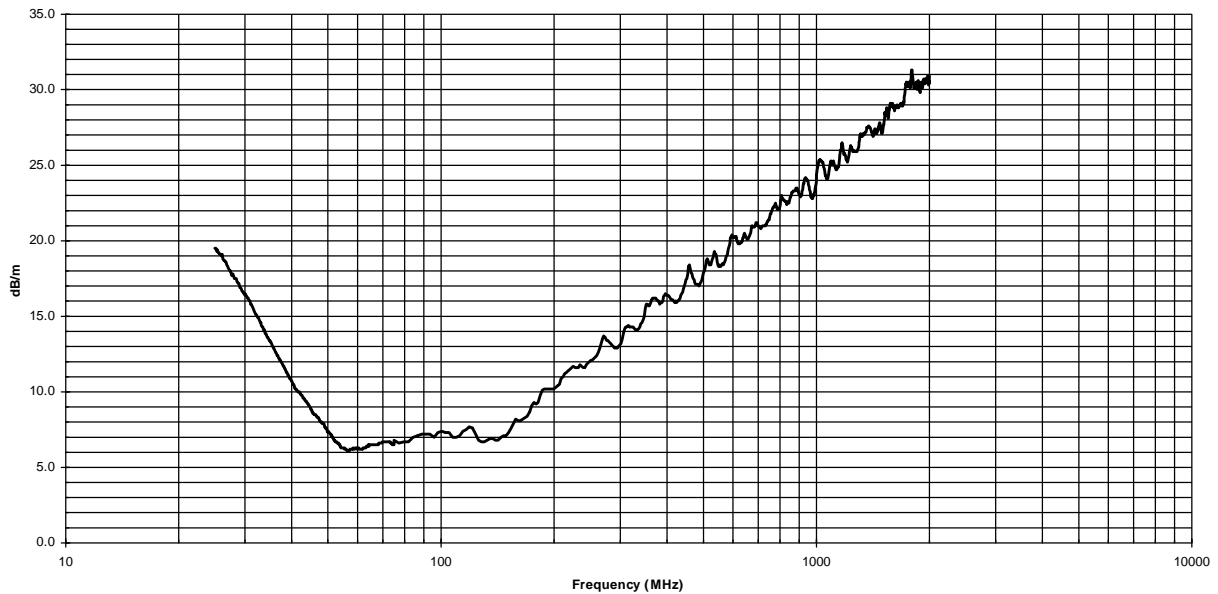

**AHD Accreditation**

United States Department of Commerce  
National Institute of Standards and Technology



**Certificate of Accreditation to ISO/IEC 17025:2005**

---

NVLAP LAB CODE: 200129-0

**AHD (Amber Helm Development, L.C.)**  
Sister Lakes, MI

*is accredited by the National Voluntary Laboratory Accreditation Program for specific services,  
listed on the Scope of Accreditation, for:*

**Electromagnetic Compatibility & Telecommunications**

*This laboratory is accredited in accordance with the recognized International Standard ISO/IEC 17025:2005.  
This accreditation demonstrates technical competence for a defined scope and the operation of a laboratory quality  
management system (refer to joint ISO-ILAC-IAF Communique dated January 2009).*

2016-06-20 through 2017-06-30  
Effective Dates



*John S. Lamm*  
For the National Voluntary Laboratory Accreditation Program

FCC Part 15 Testing for Gateway Transceiver

**FEDERAL COMMUNICATIONS COMMISSION**

Laboratory Division  
7435 Oakland Mills Road  
Columbia, MD 21046

March 06, 2015

AHD (Amber Helm Development, L.C.)  
92723 Michigan Highway 152,  
Sister Lakes, MI 49047

Attention: Gordon Helm

Re: Accreditation of AHD (Amber Helm Development, L.C.)  
Designation Number: US5339  
Test Firm Registration #: 559716

Dear Sir or Madam:

We have been notified by National Voluntary Laboratory Accreditation Program that AHD (Amber Helm Development, L.C.) has been accredited as a Conformity Assessment Body (CAB).

At this time AHD (Amber Helm Development, L.C.) is hereby designated to perform compliance testing on equipment subject to Declaration Of Conformity (DOC) and Certification under Parts 15 and 18 of the Commission's Rules.

This designation will expire upon expiration of the accreditation or notification of withdrawal of designation.

Sincerely,

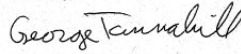

George Tannahill  
Electronics Engineer

**NARTE Seal**

