

#01_WLAN2.4GHz_802.11b 1Mbps_Edge 1_0mm_Ch11

Communication System: 802.11b ; Frequency: 2462 MHz;Duty Cycle: 1:1.01

Medium: MSL_2450_190406 Medium parameters used: $f = 2462$ MHz; $\sigma = 1.979$ S/m; $\epsilon_r = 52.565$; $\rho = 1000$ kg/m³

Ambient Temperature : 23.4 °C ; Liquid Temperature : 22.4 °C

DASY5 Configuration:

- Probe: EX3DV4 - SN3931; ConvF(7.56, 7.56, 7.56) ; Calibrated: 2018/9/27
- Sensor-Surface: 1.4mm (Mechanical Surface Detection)
- Electronics: DAE4 Sn1399; Calibrated: 2018/11/16
- Phantom: ELI v4.0; Type: QDOVA001BB; Serial: 1026
- Measurement SW: DASY52, Version 52.10 (1);SEMCAD X Version 14.6.11 (7439)

Area Scan (51x91x1): Interpolated grid: dx=1.200 mm, dy=1.200 mm

Maximum value of SAR (interpolated) = 2.05 W/kg

Zoom Scan (7x7x7)/Cube 0: Measurement grid: dx=5mm, dy=5mm, dz=5mm

Reference Value = 17.03 V/m; Power Drift = 0.17 dB

Peak SAR (extrapolated) = 2.68 W/kg

SAR(1 g) = 1.07 W/kg; SAR(10 g) = 0.444 W/kg

Maximum value of SAR (measured) = 2.04 W/kg

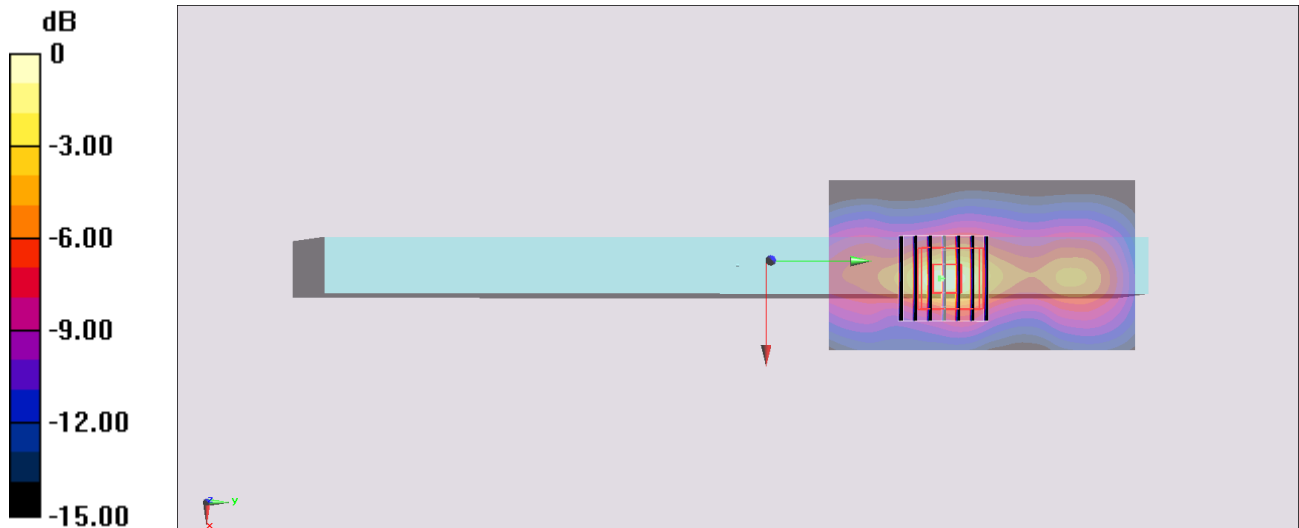

0 dB = 2.04 W/kg = 3.10 dBW/kg

#02_WLAN5GHz_802.11a 6Mbps_Edge 1_0mm_Ch52

Communication System: 802.11a ; Frequency: 5260 MHz; Duty Cycle: 1:1.054

Medium: MSL_5G_190406 Medium parameters used: $f = 5260$ MHz; $\sigma = 5.398$ S/m; $\epsilon_r = 47.819$; $\rho = 1000$ kg/m³

Ambient Temperature : 23.8 °C ; Liquid Temperature : 22.8 °C

DASY5 Configuration:

- Probe: EX3DV4 - SN3931; ConvF(4.4, 4.4, 4.4) ; Calibrated: 2018/9/27
- Sensor-Surface: 1.4mm (Mechanical Surface Detection)
- Electronics: DAE4 Sn1399; Calibrated: 2018/11/16
- Phantom: ELI v5.0; Type: QDOVA002AA; Serial: 1131
- Measurement SW: DASY52, Version 52.10 (1); SEMCAD X Version 14.6.11 (7439)

Area Scan (61x121x1): Interpolated grid: dx=1.000 mm, dy=1.000 mm

Maximum value of SAR (interpolated) = 1.30 W/kg

Zoom Scan (7x7x7)/Cube 0: Measurement grid: dx=4mm, dy=4mm, dz=1.4mm

Reference Value = 8.131 V/m; Power Drift = -0.15 dB

Peak SAR (extrapolated) = 2.53 W/kg

SAR(1 g) = 0.567 W/kg; SAR(10 g) = 0.188 W/kg

Maximum value of SAR (measured) = 1.35 W/kg

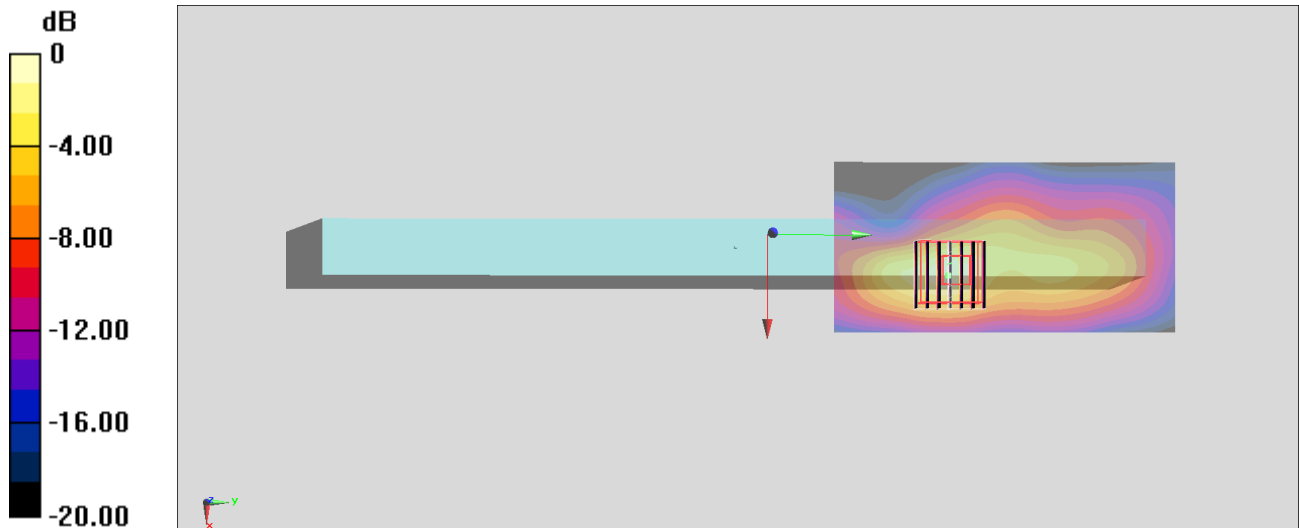

0 dB = 1.35 W/kg = 1.30 dBW/kg

#03_WLAN5GHz_802.11a_6Mbps_Edge_1_0mm_Ch144

Communication System: 802.11a; Frequency: 5720 MHz; Duty Cycle: 1:1.054

Medium: MSL_5G_190406 Medium parameters used: $f = 5720$ MHz; $\sigma = 6.007$ S/m; $\epsilon_r = 47.035$; $\rho = 1000$ kg/m³

Ambient Temperature : 23.8 °C ; Liquid Temperature : 22.8 °C

DASY5 Configuration:

- Probe: EX3DV4 - SN3931; ConvF(4.11, 4.11, 4.11) ; Calibrated: 2018/9/27
- Sensor-Surface: 1.4mm (Mechanical Surface Detection)
- Electronics: DAE4 Sn1399; Calibrated: 2018/11/16
- Phantom: ELI v5.0; Type: QDOVA002AA; Serial: 1131
- Measurement SW: DASY52, Version 52.10 (1); SEMCAD X Version 14.6.11 (7439)

Area Scan (61x121x1): Interpolated grid: dx=1.000 mm, dy=1.000 mm

Maximum value of SAR (interpolated) = 2.63 W/kg

Zoom Scan (7x7x7)/Cube 0: Measurement grid: dx=4mm, dy=4mm, dz=1.4mm

Reference Value = 22.17 V/m; Power Drift = -0.11 dB

Peak SAR (extrapolated) = 4.70 W/kg

SAR(1 g) = 0.993 W/kg; SAR(10 g) = 0.305 W/kg

Maximum value of SAR (measured) = 2.65 W/kg

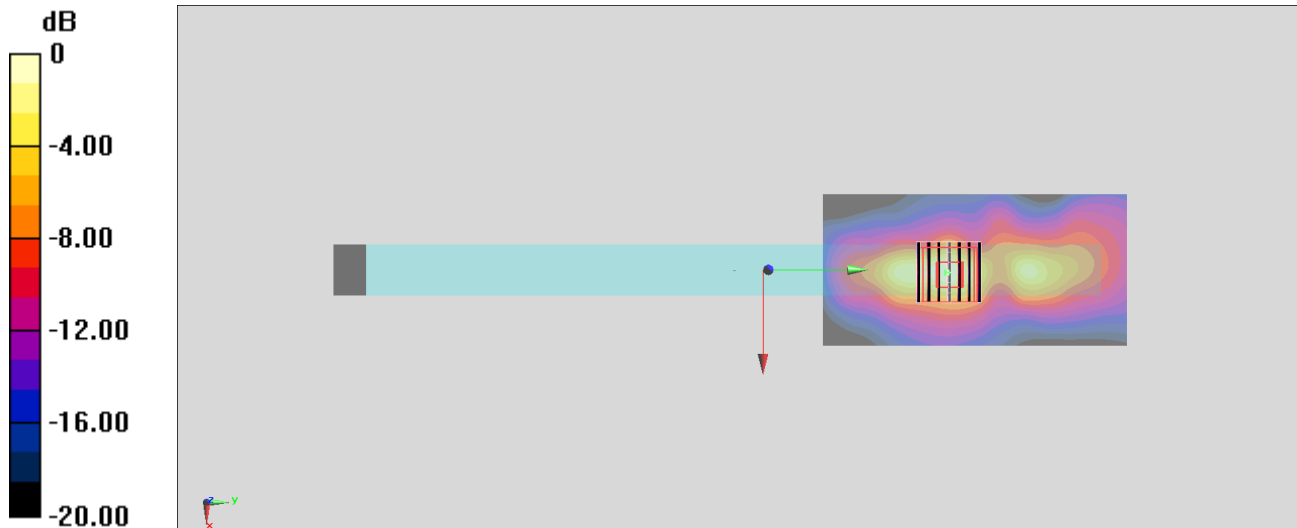

0 dB = 2.65 W/kg = 4.23 dBW/kg

#04_WLAN5GHz_802.11a 6Mbps_Edge 1_0mm_Ch149

Communication System: 802.11a ; Frequency: 5745 MHz; Duty Cycle: 1:1.054

Medium: MSL_5G_190406 Medium parameters used : $f = 5745$ MHz; $\sigma = 6.04$ S/m; $\epsilon_r = 47.007$; $\rho = 1000$ kg/m³

Ambient Temperature : 23.8 °C ; Liquid Temperature : 22.8 °C

DASY5 Configuration:

- Probe: EX3DV4 - SN3931; ConvF(4.11, 4.11, 4.11) ; Calibrated: 2018/9/27
- Sensor-Surface: 1.4mm (Mechanical Surface Detection)
- Electronics: DAE4 Sn1399; Calibrated: 2018/11/16
- Phantom: ELI v5.0; Type: QDOVA002AA; Serial: 1131
- Measurement SW: DASY52, Version 52.10 (1); SEMCAD X Version 14.6.11 (7439)

Area Scan (61x121x1): Interpolated grid: dx=1.000 mm, dy=1.000 mm

Maximum value of SAR (interpolated) = 1.67 W/kg

Zoom Scan (7x7x7)/Cube 0: Measurement grid: dx=4mm, dy=4mm, dz=1.4mm

Reference Value = 10.33 V/m; Power Drift = -0.16 dB

Peak SAR (extrapolated) = 3.70 W/kg

SAR(1 g) = 0.789 W/kg; SAR(10 g) = 0.235 W/kg

Maximum value of SAR (measured) = 1.93 W/kg

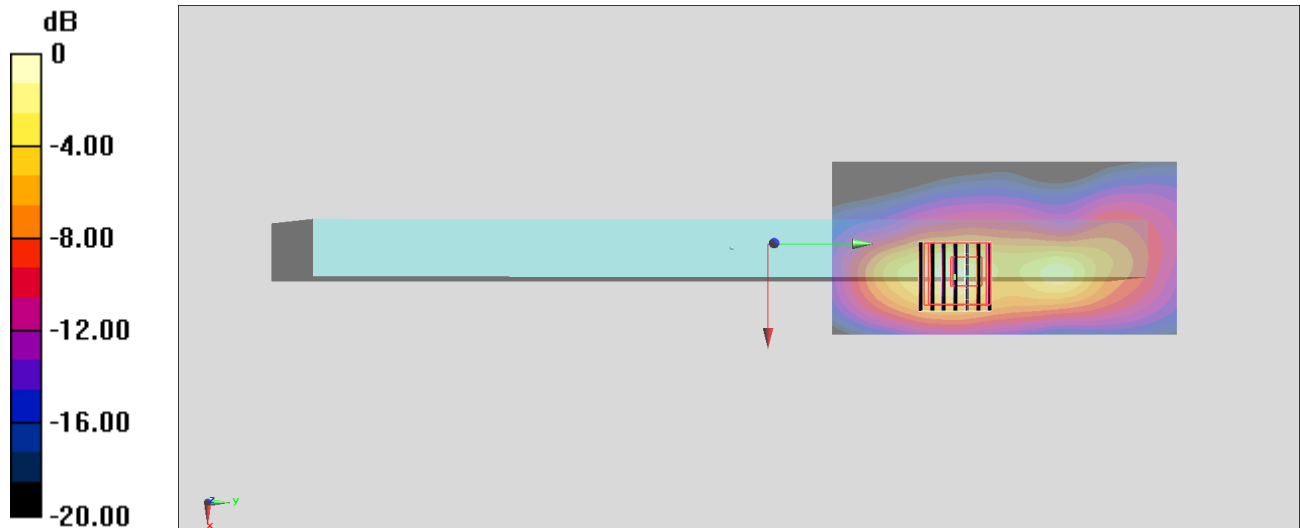

0 dB = 1.93 W/kg = 2.86 dBW/kg

#05_Bluetooth_1Mbps_Edge_1_0mm_Ch78

Communication System: Bluetooth ; Frequency: 2480 MHz; Duty Cycle: 1:1.297

Medium: MSL_2450_190406 Medium parameters used: $f = 2480$ MHz; $\sigma = 2.004$ S/m; $\epsilon_r = 52.541$; $\rho = 1000$ kg/m³

Ambient Temperature : 23.4 °C ; Liquid Temperature : 22.4 °C

DASY5 Configuration:

- Probe: EX3DV4 - SN3931; ConvF(7.56, 7.56, 7.56) ; Calibrated: 2018/9/27
- Sensor-Surface: 1.4mm (Mechanical Surface Detection)
- Electronics: DAE4 Sn1399; Calibrated: 2018/11/16
- Phantom: ELI v4.0; Type: QDOVA001BB; Serial: 1026
- Measurement SW: DASY52, Version 52.10 (1); SEMCAD X Version 14.6.11 (7439)

Area Scan (51x91x1): Interpolated grid: dx=1.200 mm, dy=1.200 mm

Maximum value of SAR (interpolated) = 0.0341 W/kg

Zoom Scan (7x7x7)/Cube 0: Measurement grid: dx=5mm, dy=5mm, dz=5mm

Reference Value = 2.397 V/m; Power Drift = 0.18 dB

Peak SAR (extrapolated) = 0.0440 W/kg

SAR(1 g) = 0.018 W/kg; SAR(10 g) = 0.00778 W/kg

Maximum value of SAR (measured) = 0.0346 W/kg

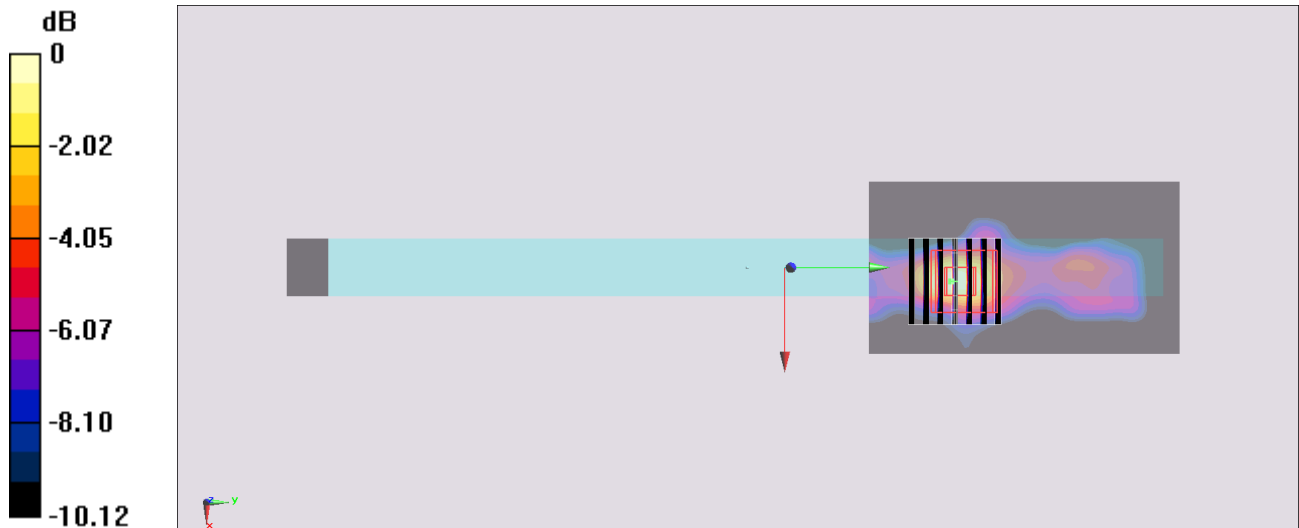

0 dB = 0.0346 W/kg = -14.61 dBW/kg