



FCC DoC TEST REPORT

REPORT NO. : FD110407E08

MODEL NO. : AR5BBU22

RECEIVED : Apr. 07, 2011

TESTED : Apr. 15 to 26, 2011

ISSUED: May 11, 2011

APPLICANT : Atheros Communications, Inc.

ADDRESS : 1700 Technology Drive, San Jose, CA 95110

ISSUED BY: Bureau Veritas Consumer Products Services (H.K.)
Ltd., Taoyuan Branch Hsin Chu Laboratory

LAB ADDRESS: No. 81-1, Lu Liao Keng, 9th Ling, Wu Lung Tsuen,
Chiung Lin Hsiang, Hsin Chu Hsien 307, Taiwan

TEST LOCATION (1): No. 81-1, Lu Liao Keng, 9th Ling, Wu Lung Tsuen,
Chiung Lin Hsiang, Hsin Chu Hsien 307, Taiwan

TEST LOCATION (2): No. 49, Ln. 206, Wende Rd., Shangshan Tsuen,
Chiung Lin Hsiang, Hsin Chu Hsien 307, Taiwan

This test report consists of 23 pages in total. It may be duplicated completely for legal use with the approval of the applicant. It should not be reproduced except in full, without the written approval of our laboratory. The client should not use it to claim product certification, approval, or endorsement by TAF, NVLAP, NIST, or any government agency. The test results in the report only apply to the tested sample. The test results in this report are traceable to the national or international standards.



Table of Contents

RELEASE CONTROL RECORD.....	3
1 CERTIFICATION.....	4
2 SUMMARY OF TEST RESULTS.....	5
2.1 MEASUREMENT UNCERTAINTY	5
3 GENERAL INFORMATION	6
3.1 GENERAL DESCRIPTION OF EUT.....	6
3.2 ANTENNA SPECIFICATIONS	7
3.3 DESCRIPTION OF SUPPORT UNITS.....	8
3.4 CONFIGURATION OF SYSTEM UNDER TEST	8
4 EMISSION TEST.....	9
4.1 CONDUCTED EMISSION MEASUREMENT	9
4.1.1 LIMITS OF CONDUCTED EMISSION MEASUREMENT.....	9
4.1.2 TEST INSTRUMENTS	9
4.1.3 TEST PROCEDURE	10
4.1.4 DEVIATION FROM TEST STANDARD	10
4.1.5 TEST SETUP	11
4.1.6 EUT OPERATING CONDITIONS.....	11
4.1.7 TEST RESULTS.....	12
4.2 RADIATED EMISSION MEASUREMENT	14
4.2.1 LIMITS OF RADIATED EMISSION MEASUREMENT.....	14
4.2.2 TEST INSTRUMENTS	15
4.2.3 TEST PROCEDURE	16
4.2.4 DEVIATION FROM TEST STANDARD	16
4.2.5 TEST SETUP	17
4.2.6 EUT OPERATING CONDITIONS.....	17
4.2.7 TEST RESULTS.....	18
5 INFORMATION ON THE TESTING LABORATORIES	22
6 APPENDIX A - MODIFICATIONS RECORDERS FOR ENGINEERING CHANGES TO THE EUT BY THE LAB.....	23



RELEASE CONTROL RECORD

ISSUE NO.	REASON FOR CHANGE	DATE ISSUED
FD110407E08	Original release	May 11, 2011



1 CERTIFICATION

PRODUCT : Bluetooth USB module
BRAND NAME : Atheros
MODEL NO.: AR5BBU22
TEST SAMPLE : R&D SAMPLE
APPLICANT : Atheros Communications, Inc.
TESTED : Apr. 15 to 26, 2011
STANDARDS : FCC Part 15, Subpart B, Class B
ANSI C63.4-2003

The above equipment (Model: AR5BBU22) has been tested by **Bureau Veritas Consumer Products Services (H.K.) Ltd., Taoyuan Branch**, and was in compliance with the requirement of the above standards. The test record, data evaluation & Equipment Under Test (EUT) configurations represented herein are true and accurate accounts of the measurements of the sample's EMC characteristics under the conditions specified in this report.

PREPARED BY : Midoli Peng, **DATE:** May 11, 2011
(Midoli Peng, Specialist)

APPROVED BY : May Chen, **DATE:** May 11, 2011
(May Chen, Deputy Manager)

2 SUMMARY OF TEST RESULTS

Standard	Test Type	Result	Remarks
FCC Part 15, Subpart B, Class B	Conducted Test	PASS	Meets Class B Limit Minimum passing margin is -20.06 dB at 0.373 MHz
	Radiated Test	PASS	Meets Class B Limit Minimum passing margin is -3.0 dB at 304.62 MHz

2.1 MEASUREMENT UNCERTAINTY

Where relevant, the following measurement uncertainty levels have been estimated for tests performed on the EUT as specified in CISPR 16-4-2:

This uncertainty represents an expanded uncertainty expressed at approximately the 95% confidence level using a coverage factor of $k=2$.

Measurement	Value
Conducted emissions	2.45 dB
Radiated emissions (30MHz-1GHz)	3.3 dB
Radiated emissions (1GHz -18GHz)	2.19 dB
Radiated emissions (18GHz -40GHz)	2.55 dB

3 GENERAL INFORMATION

3.1 GENERAL DESCRIPTION OF EUT

PRODUCT	Bluetooth USB module
MODEL NO.	AR5BBU22
POWER SUPPLY	DC 3.3V from host equipment
POWER CORD	NA
DATA CABLE SUPPLIED	NA
I/O PORTS	NA
ASSOCIATED DEVICES	NA

NOTE:

1. The Bluetooth supports version 4.0.
2. There are three versions of EUT which are identical to each other in all aspects except for the following table

Versions	Variations in memory
-80	EEPROM
-90	SFLASH
-180	OTP

From the above Versions, the worst case was found in **Version -80**. Therefore only the test data of the version was recorded in this report.

- * The EUT has two shielding design. The deviated version has two pins removed and 4 holes on the top of shielding.
- * The worst-case scenario has been investigated in radiated test with same power level and found no difference.
- * The test data reflects the worst-case scenarios.

3. For radiated : The EUT's antenna was pre-tested under the following modes:

Test Mode	Description
Mode A	X-Y axis
Mode B	Y-Z axis
Mode C	X-Z axis

From the above modes, the worst case was found in **Mode B**. Therefore only the test data of the mode was recorded in this report.

4. For a more detailed features description, please refer to the manufacturer's specifications or the User's Manual.

3.2 ANTENNA SPECIFICATIONS

There is one antenna provided to this EUT, please refer to the following table:

Brand	Model	Antenna Type	Connector	Antenna Gain (dBi)
Atheros	NA	Printed	NA	1.14

1. Note: The antenna gain is Total (H+V).

3.3 DESCRIPTION OF SUPPORT UNITS

The EUT has been tested as an independent unit together with other necessary accessories or support units. The following support units or accessories were used to form a representative test configuration during the tests.

NO.	PRODUCT	BRAND	MODEL NO.	SERIAL NO.	FCC ID
1	NOTEBOOK COMPUTER	DELL	PP32LA	GSLB32S	FCC DoC
2	EXTENSION CARD	Atheros	NA	NA	NA

NO.	SIGNAL CABLE DESCRIPTION OF THE ABOVE SUPPORT UNITS
1	NA
2	NA

NOTE: All power cords of the above support units are non shielded (1.8m).

3.4 CONFIGURATION OF SYSTEM UNDER TEST

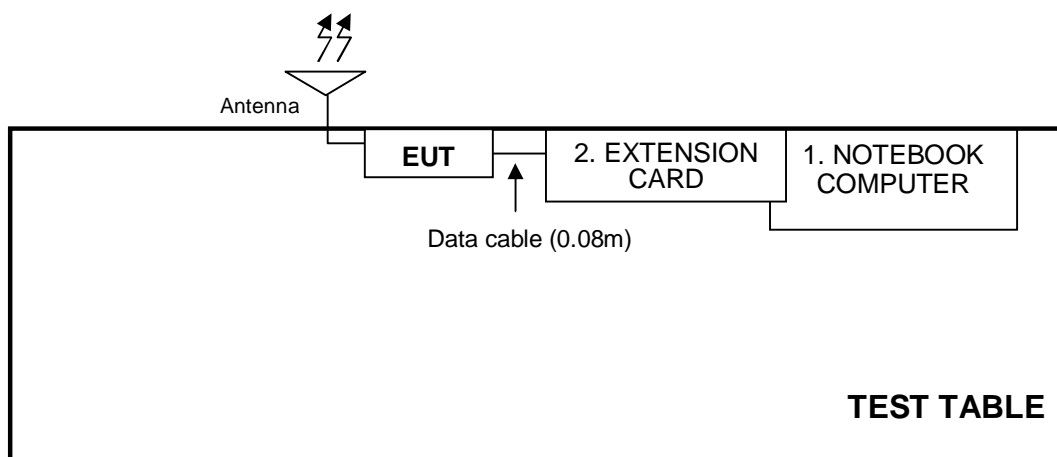

4 EMISSION TEST

4.1 CONDUCTED EMISSION MEASUREMENT

4.1.1 LIMITS OF CONDUCTED EMISSION MEASUREMENT

TEST STANDARD:

FCC Part 15, Subpart B (Section: 15.107)

FREQUENCY (MHz)	Class A (dBuV)		Class B (dBuV)	
	Quasi-peak	Average	Quasi-peak	Average
0.15 - 0.5	79	66	66 - 56	56 - 46
0.50 - 5.0	73	60	56	46
5.0 - 30.0	73	60	60	50

NOTE: (1) The lower limit shall apply at the transition frequencies.

(2) The limit decreases linearly with the logarithm of the frequency in the range 0.15 to 0.50 MHz

(3) All emanation from a class A/B digital device or system, including any network of conductors and apparatus connected thereto, shall not exceed the level of field strengths specified above.

4.1.2 TEST INSTRUMENTS

DESCRIPTION & MANUFACTURER	MODEL NO.	SERIAL NO.	CALIBRATED DATE	CALIBRATED UNTIL
Test Receiver	ESCS 30	100375	Mar. 09, 2011	Mar. 08, 2012
Line-Impedance Stabilization Network (for EUT)	NSLK 8127	8127-522	Sep. 08, 2010	Sep. 07, 2011
Line-Impedance Stabilization Network (for Peripheral)	ESH3-Z5	848773/004	Nov. 03, 2010	Nov. 02, 2011
RF Cable (JYEBAO)	5DFB	COCCAB-002	Aug. 30, 2010	Aug. 29, 2011
50 ohms Terminator	50	3	Nov. 03, 2010	Nov. 02, 2011
Software	BV ADT_Cond_V7.3.7	NA	NA	NA

Note:

1. The calibration interval of the above test instruments is 12 months and the calibrations are traceable to NML/ROC and NIST/USA.
2. The test was performed in Shielded Room No. C.
3. The VCCI Con C Registration No. is C-3611.

4.1.3 TEST PROCEDURE

The basic test procedure was in accordance with ANSI C63.4-2003 (section 7)

- a. The EUT was placed 0.4 meters from the conducting wall of the shielded room with EUT being connected to the power mains through a line impedance stabilization network (LISN). Other support units were connected to the power mains through another LISN. The two LISNs provide 50 Ohm/ 50uH of coupling impedance for the measuring instrument.
- b. Both lines of the power mains connected to the EUT were checked for maximum conducted interference.
- c. The frequency range from 150 kHz to 30 MHz was searched. Emission levels over 10dB under the prescribed limits could not be reported.

4.1.4 DEVIATION FROM TEST STANDARD

No deviation

4.1.5 TEST SETUP

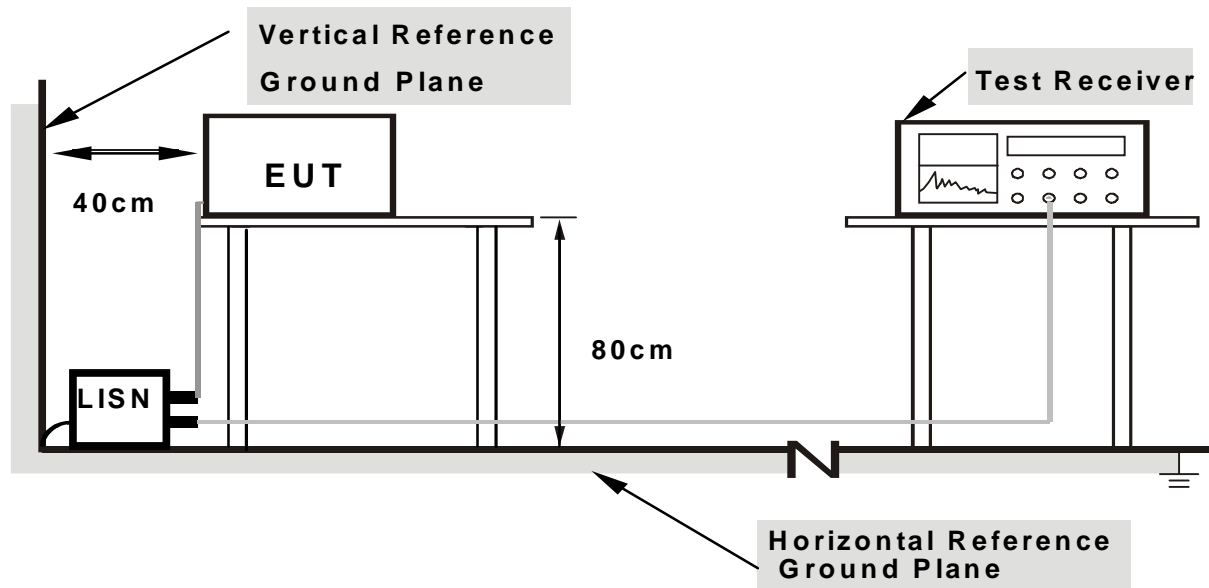

- Note:**
1. Support units were connected to second LISN.
 2. Both of LISNs (AMN) are 80 cm from EUT and at least 80 from other units and other metal planes

For the actual test configuration, please refer to the related item – Photographs of the Test Configuration.

4.1.6 EUT OPERATING CONDITIONS

1. Connect the EUT with the support unit 1 (Notebook Computer) which is placed on a testing table.
2. The communication partner run test program “ART R0.2B25” & “BtTest_egret.exe V1_0_B17” to enable EUT under transmission/receiving condition continuously at specific channel frequency.



A D T

4.1.7 TEST RESULTS

TEST MODE	Mode 1	6dB BANDWIDTH	9kHz
INPUT POWER (SYSTEM)	120Vac, 60Hz	PHASE	Line (L)
ENVIRONMENTAL CONDITIONS	21deg. C, 67%RH, 1023hPa	TESTED BY	Frank Liu

No	Freq. [MHz]	Corr. Factor [dB]	Reading Value [dB (uV)]		Emission Level [dB (uV)]		Limit [dB (uV)]		Margin (dB)	
			Q.P.	AV.	Q.P.	AV.	Q.P.	AV.	Q.P.	AV.
			1	0.232	0.13	30.97	-	31.10	-	62.38
2	0.373	0.13	35.13	-	35.26	-	58.44	48.44	-23.18	-
3	0.392	0.13	33.69	-	33.82	-	58.02	48.02	-24.20	-
4	2.184	0.16	26.41	-	26.57	-	56.00	46.00	-29.43	-
5	4.633	0.23	24.20	-	24.43	-	56.00	46.00	-31.57	-
6	20.504	0.68	22.80	-	23.48	-	60.00	50.00	-36.52	-

- REMARKS:**
1. Q.P. and AV. are abbreviations of quasi-peak and average individually.
 2. "-": The Quasi-peak reading value also meets average limit and measurement with the average detector is unnecessary.
 3. The emission levels of other frequencies were very low against the limit.
 4. Margin value = Emission level - Limit value
 5. Correction factor = Insertion loss + Cable loss
 6. Emission Level = Correction Factor + Reading Value.

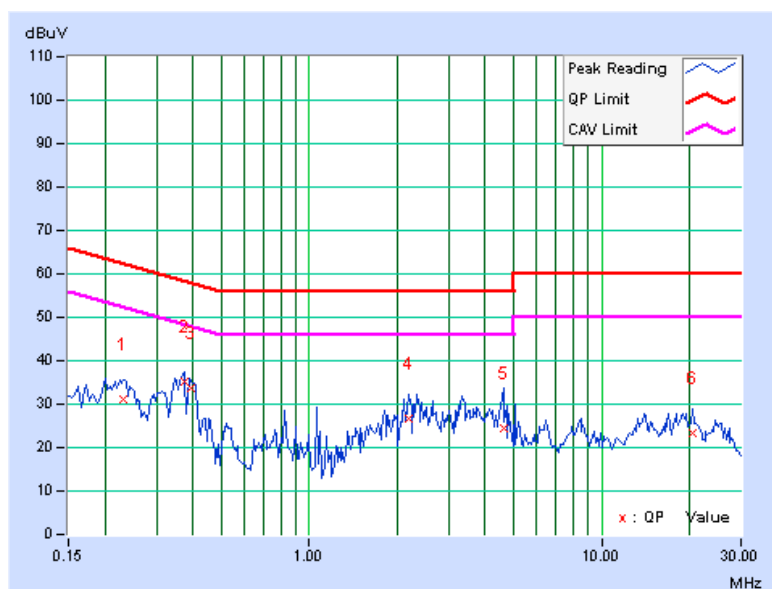

TEST MODE	Mode 1	6dB BANDWIDTH	9kHz
INPUT POWER (SYSTEM)	120Vac, 60Hz	PHASE	Neutral (N)
ENVIRONMENTAL CONDITIONS	21deg. C, 67%RH, 1023hPa	TESTED BY	Frank Liu

No	Freq. [MHz]	Corr. Factor (dB)	Reading Value [dB (uV)]		Emission Level [dB (uV)]		Limit [dB (uV)]		Margin (dB)	
			Q.P.	AV.	Q.P.	AV.	Q.P.	AV.	Q.P.	AV.
1	0.150	0.12	32.52	-	32.64	-	66.00	56.00	-33.36	-
2	0.373	0.15	38.23	-	38.38	-	58.44	48.44	-20.06	-
3	0.392	0.15	34.88	-	35.03	-	58.02	48.02	-22.99	-
4	1.086	0.16	26.19	-	26.35	-	56.00	46.00	-29.65	-
5	2.465	0.21	28.20	-	28.41	-	56.00	46.00	-27.59	-
6	20.418	1.45	23.11	-	24.56	-	60.00	50.00	-35.44	-

- REMARKS:**
1. Q.P. and AV. are abbreviations of quasi-peak and average individually.
 2. "-": The Quasi-peak reading value also meets average limit and measurement with the average detector is unnecessary.
 3. The emission levels of other frequencies were very low against the limit.
 4. Margin value = Emission level - Limit value
 5. Correction factor = Insertion loss + Cable loss
 6. Emission Level = Correction Factor + Reading Value.

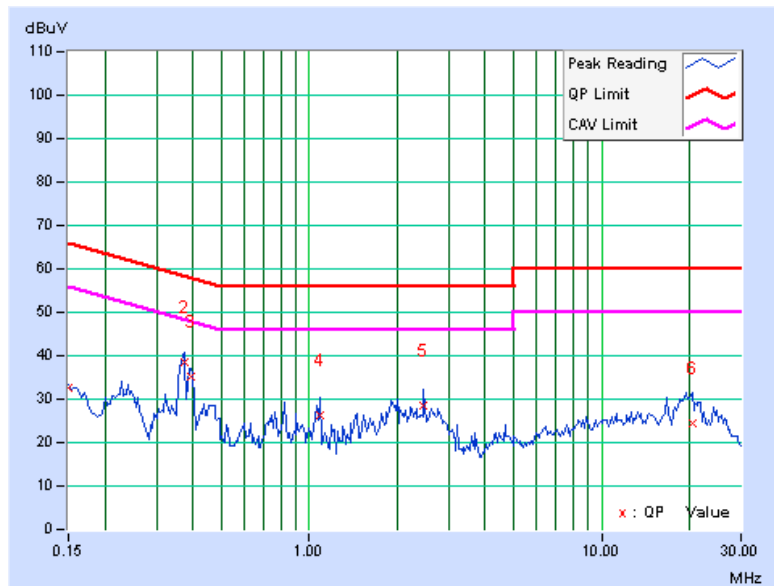

4.2 RADIATED EMISSION MEASUREMENT

4.2.1 LIMITS OF RADIATED EMISSION MEASUREMENT

TEST STANDARD:

FCC Part 15, Subpart B (Section: 15.109)

FOR FREQUENCY BELOW 1000 MHz (47 CFR Part 15 Subpart B)

FREQUENCY (MHz)	Class A (at 10m)		Class B (at 3m)	
	uV/m	dBuV/m	uV/m	dBuV/m
30 – 88	90	39.1	100	40.0
88 – 216	150	43.5	150	43.5
216 - 960	210	46.4	200	46.0
Above 960	300	49.5	500	54.0

LIMIT OF RADIATED EMISSION OF FCC PART 15, SUBPART B FOR FREQUENCY ABOVE 1000 MHz

FREQUENCY (MHz)	Class A (dBuV/m) (at 3m)		Class B (dBuV/m) (at 3m)	
	PEAK	AVERAGE	PEAK	AVERAGE
Above 1000	80.0	60.0	74.0	54.0

Note: (1) The lower limit shall apply at the transition frequencies.

(2) Emission level (dBuV/m) = 20 log Emission level (uV/m).

(3) All emanation from a class A/B digital device or system, including any network of conductors and apparatus connected thereto, shall not exceed the level of field strengths specified above.

FREQUENCY RANGE OF RADIATED MEASUREMENT (For unintentional radiators)

Highest frequency generated or used in the device or on which the device operates or tunes (MHz)	Upper frequency of measurement Range (MHz)
Below 1.705	30
1.705 – 108	1000
108 – 500	2000
500 – 1000	5000
Above 1000	5 th harmonic of the highest frequency or 40 GHz, whichever is lower

4.2.2 TEST INSTRUMENTS

DESCRIPTION & MANUFACTURER	MODEL NO.	SERIAL NO.	CALIBRATED DATE	CALIBRATED UNTIL
Agilent Spectrum Analyzer	E4446A	MY48250254	July 14, 2010	July 13, 2011
Agilent Pre-Selector	N9039A	MY46520311	July 14, 2010	July 13, 2011
Agilent Signal Generator	N5181A	MY49060517	July 14, 2010	July 13, 2011
Mini-Circuits Pre-Amplifier	ZFL-1000VH2B	AMP-ZFL-03	Nov. 16, 2010	Nov. 15, 2011
Agilent Pre-Amplifier	8449B	3008A02578	July 05, 2010	July 04, 2011
Miteq Pre-Amplifier	AFS33-1800265 0-30-8P-44	881786	NA	NA
SCHWARZBECK Trilog Broadband Antenna	VULB 9168	9168-360	Apr. 29, 2010	Apr. 28, 2011
AISI Horn_Antenna	AIH.8018	0000320091110	Nov. 12, 2010	Nov. 11, 2011
SCHWARZBECK Horn_Antenna	BBHA 9170	9170-424	Oct. 08, 2010	Oct. 07, 2011
RF CABLE	NA	RF104-201 RF104-203 RF104-204	Dec. 27, 2010	Dec. 26, 2011
RF Cable	NA	CHGCAB_001	NA	NA
Software	ADT_Radiated_V8.7.05	NA	NA	NA
CT Antenna Tower & Turn Table	NA	NA	NA	NA

Note: 1. The calibration interval of the above test instruments is 12 months and the calibrations are traceable to NML/ROC and NIST/USA.

2. The horn antenna, preamplifier (model: 8449B) are used only for the measurement of emission frequency above 1GHz if tested.

3. The test was performed in 966 Chamber No. G.

4. The FCC Site Registration No. is 966073.

5. The VCCI Site Registration No. is G-137.

6. The CANADA Site Registration No. is IC 7450H-2.

4.2.3 TEST PROCEDURE

The basic test procedure was in accordance with ANSI C63.4-2003 (section 8)

- a. The EUT was placed on the top of a rotating table 0.8 meters above the ground at a 3 meter chamber. The table was rotated 360 degrees to determine the position of the highest radiation.
- b. The EUT was set 3 meters away from the interference-receiving antenna, which was mounted on the top of a variable-height antenna tower.
- c. The height of antenna is varied from one meter to four meters above the ground to determine the maximum value of the field strength. Both horizontal and vertical polarizations of the antenna are set to make the measurement.
- d. For each suspected emission, the EUT was arranged to its worst case and then the antenna was tuned to heights from 1 meter to 4 meters and the turn table was turned from 0 degrees to 360 degrees to find the maximum reading.
- e. The test-receiver system was set to quasi-peak detect function and specified bandwidth with maximum hold mode when the test frequency is below 1 GHz.
- f. The test-receiver system was set to peak and average detect function and specified bandwidth with maximum hold mode when the test frequency is above 1 GHz. If the peak reading value also meets average limit, measurement with the average detector is unnecessary.

NOTE:

1. The resolution bandwidth and video bandwidth of test receiver/spectrum analyzer is 120kHz for Quasi-peak detection (QP) at frequency below 1GHz.
2. The resolution bandwidth is 1MHz and video bandwidth of test receiver/spectrum analyzer is 3MHz for Peak detection at frequency above 1GHz. The resolution bandwidth of test receiver/spectrum analyzer is 1 MHz for Average detection (AV) at frequency above 1GHz.
3. For measurement of frequency above 1000 MHz, the EUT was set 3 meters away from the interference-receiving antenna.

4.2.4 DEVIATION FROM TEST STANDARD

No deviation

4.2.5 TEST SETUP

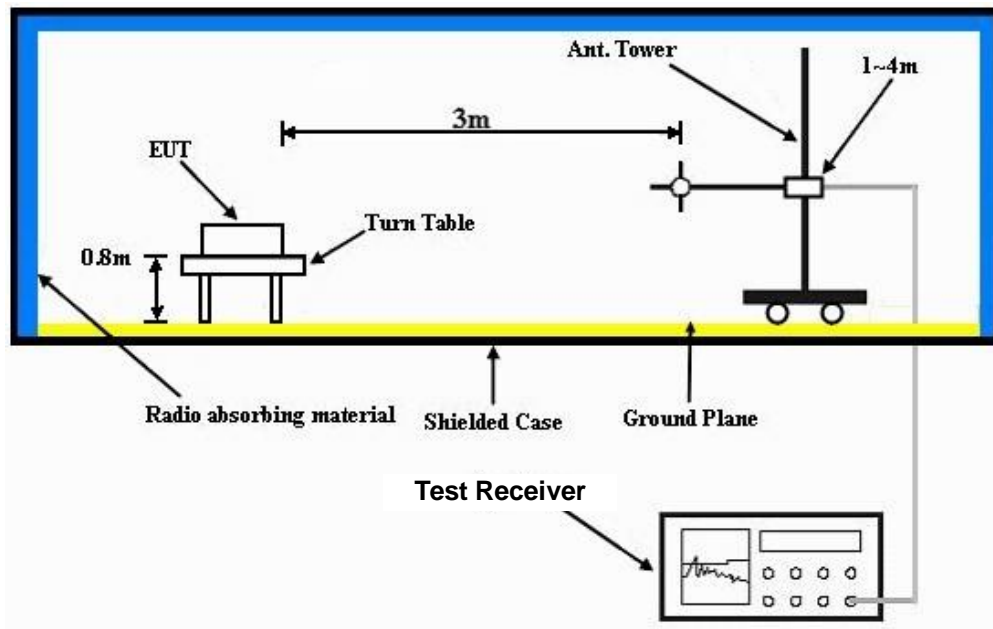

For the actual test configuration, please refer to the related item – Photographs of the Test Configuration.

4.2.6 EUT OPERATING CONDITIONS

Same as 4.1.6

4.2.7 TEST RESULTS

TEST MODE	Mode 1	FREQUENCY RANGE	Below 1GHz
INPUT POWER (SYSTEM)	120Vac, 60 Hz	DETECTOR FUNCTION & BANDWIDTH	Quasi-Peak, 120kHz
ENVIRONMENTAL CONDITIONS	15 deg. C, 68 %RH, 1023hPa	TESTED BY	Frank Liu

ANTENNA POLARITY & TEST DISTANCE: HORIZONTAL AT 3 M								
No.	Freq. (MHz)	Emission Level (dBuV/m)	Limit (dBuV/m)	Margin (dB)	Antenna Height (m)	Table Angle (Degree)	Raw Value (dBuV)	Correction Factor (dB/m)
1	161.33	36.72 QP	43.50	-6.78	2.00 H	264	22.18	14.54
2	239.96	34.81 QP	46.00	-11.19	1.00 H	114	21.91	12.90
3	304.62	43.00 QP	46.00	-3.00	1.00 H	283	27.44	15.56
4	321.79	40.32 QP	46.00	-5.68	1.00 H	280	24.38	15.94
5	498.01	35.30 QP	46.00	-10.70	2.00 H	202	15.25	20.05
6	604.82	33.21 QP	46.00	-12.79	1.00 H	278	10.77	22.44

- REMARKS:**
1. Emission level(dBuV/m)=Raw Value(dBuV) + Correction Factor(dB/m)
 2. Correction Factor(dB/m) = Antenna Factor (dB/m) + Cable Factor (dB)
 3. The other emission levels were very low against the limit.
 4. Margin value = Emission level – Limit value.

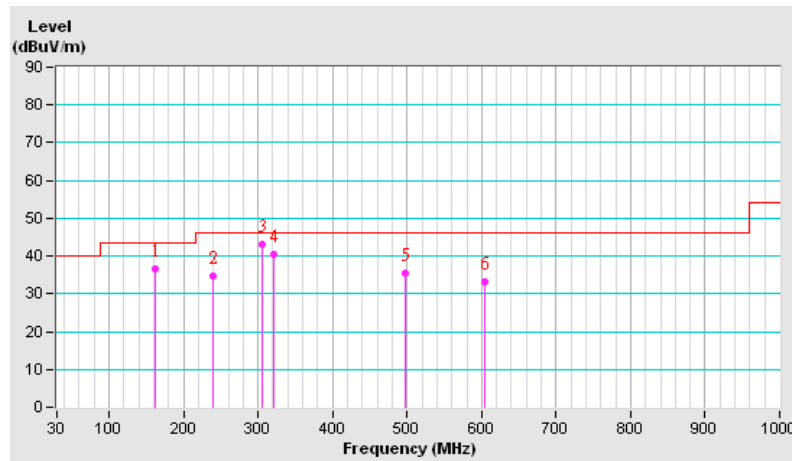



A D T

TEST MODE	Mode 1	FREQUENCY RANGE	Below 1GHz
INPUT POWER (SYSTEM)	120Vac, 60 Hz	DETECTOR FUNCTION & BANDWIDTH	Quasi-Peak, 120kHz
ENVIRONMENTAL CONDITIONS	15 deg. C, 68 %RH, 1023hPa	TESTED BY	Frank Liu

ANTENNA POLARITY & TEST DISTANCE: VERTICAL AT 3 M								
No.	Freq. (MHz)	Emission Level (dBuV/m)	Limit (dBuV/m)	Margin (dB)	Antenna Height (m)	Table Angle (Degree)	Raw Value (dBuV)	Correction Factor (dB/m)
1	36.04	36.87 QP	40.00	-3.13	1.00 V	269	23.33	13.54
2	161.09	36.54 QP	43.50	-6.96	1.00 V	130	21.97	14.57
3	303.08	34.46 QP	46.00	-11.54	1.50 V	73	18.93	15.53
4	497.77	37.31 QP	46.00	-8.69	1.50 V	274	17.26	20.05
5	607.07	31.00 QP	46.00	-15.00	1.00 V	240	8.53	22.47
6	900.64	34.61 QP	46.00	-11.39	1.00 V	281	7.80	26.81

- REMARKS:**
1. Emission level(dBuV/m)=Raw Value(dBuV) + Correction Factor(dB/m)
 2. Correction Factor(dB/m) = Antenna Factor (dB/m) + Cable Factor (dB)
 3. The other emission levels were very low against the limit.
 4. Margin value = Emission level – Limit value.

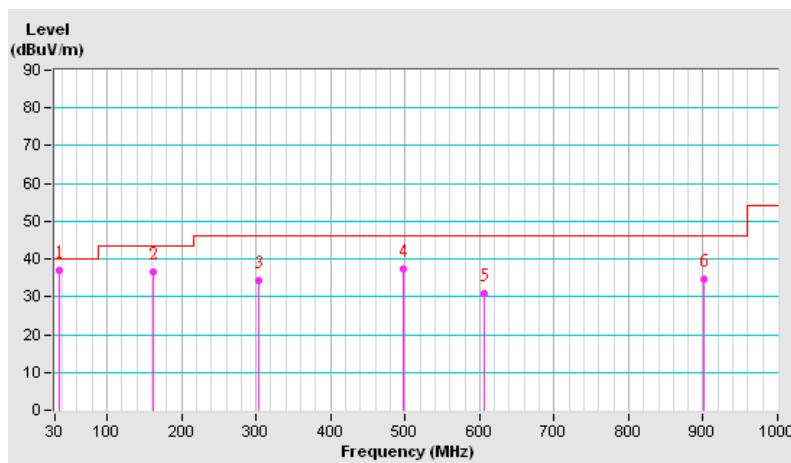



A D T

TEST MODE	Mode 1	FREQUENCY RANGE	1000~12500MHz
INPUT POWER (SYSTEM)	120Vac, 60 Hz	DETECTOR FUNCTION & BANDWIDTH	Peak (PK) Average (AV) 1 MHz
ENVIRONMENTAL CONDITIONS	17 deg. C, 67 %RH, 1023hPa	TESTED BY	Kent Liu

ANTENNA POLARITY & TEST DISTANCE: HORIZONTAL AT 3 M								
No.	Freq. (MHz)	Emission Level (dBuV/m)	Limit (dBuV/m)	Margin (dB)	Antenna Height (m)	Table Angle (Degree)	Raw Value (dBuV)	Correction Factor (dB/m)
1	2480.00	41.60 PK	74.00	-32.40	1.43 H	104	9.65	31.95
2	2480.00	28.40 AV	54.00	-25.60	1.43 H	104	-3.55	31.95
3	3000.00	46.70 PK	74.00	-27.30	1.21 H	134	13.66	33.04
4	3000.00	40.20 AV	54.00	-13.80	1.21 H	134	7.16	33.04

- REMARKS:**
1. Emission level(dBuV/m)=Raw Value(dBuV) + Correction Factor(dB/m)
 2. Correction Factor(dB/m) = Antenna Factor (dB/m) + Cable Factor (dB)
 3. The other emission levels were very low against the limit.
 4. Margin value = Emission level – Limit value.

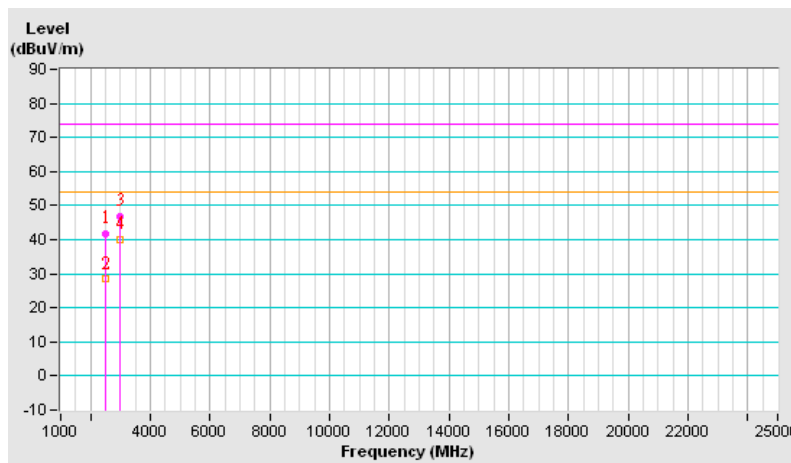



A D T

TEST MODE	Mode 1	FREQUENCY RANGE	1000~12500MHz
INPUT POWER (SYSTEM)	120Vac, 60 Hz	DETECTOR FUNCTION & BANDWIDTH	Peak (PK) Average (AV) 1 MHz
ENVIRONMENTAL CONDITIONS	17 deg. C, 67 %RH, 1023hPa	TESTED BY	Kent Liu

ANTENNA POLARITY & TEST DISTANCE: VERTICAL AT 3 M								
No.	Freq. (MHz)	Emission Level (dBuV/m)	Limit (dBuV/m)	Margin (dB)	Antenna Height (m)	Table Angle (Degree)	Raw Value (dBuV)	Correction Factor (dB/m)
1	2480.00	40.70 PK	74.00	-33.30	1.13 V	326	8.75	31.95
2	2480.00	28.50 AV	54.00	-25.50	1.13 V	326	-3.45	31.95
3	3000.00	49.30 PK	74.00	-24.70	1.31 V	314	16.26	33.04
4	3000.00	46.60 AV	54.00	-7.40	1.31 V	314	13.56	33.04

- REMARKS:**
1. Emission level(dBuV/m)=Raw Value(dBuV) + Correction Factor(dB/m)
 2. Correction Factor(dB/m) = Antenna Factor (dB/m) + Cable Factor (dB)
 3. The other emission levels were very low against the limit.
 4. Margin value = Emission level – Limit value.

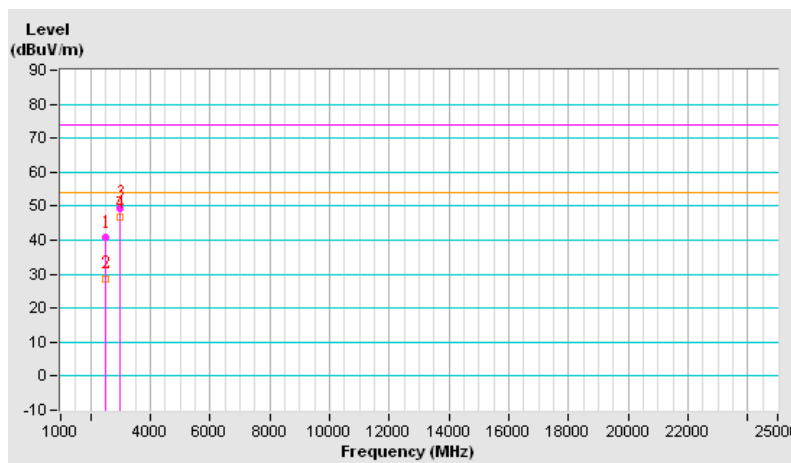



5 INFORMATION ON THE TESTING LABORATORIES

We, Bureau Veritas Consumer Products Services (H.K.) Ltd., Taoyuan Branch, were founded in 1988 to provide our best service in EMC, Radio, Telecom and Safety consultation. Our laboratories are accredited and approved according to ISO/IEC 17025.

Copies of accreditation certificates of our laboratories obtained from approval agencies can be downloaded from our web site: www.adt.com.tw/index.5.phtml.

If you have any comments, please feel free to contact us at the following:

Linko EMC/RF Lab:

Tel: 886-2-26052180

Fax: 886-2-26052943

Hsin Chu EMC/RF Lab:

Tel: 886-3-5935343

Fax: 886-3-5935342

Hwa Ya EMC/RF/Safety/Telecom Lab:

Tel: 886-3-3183232

Fax: 886-3-3185050

Email: service@adt.com.tw

Web Site: www.adt.com.tw

The address and road map of all our labs can be found in our web site also.

6 APPENDIX A - MODIFICATIONS RECORDERS FOR ENGINEERING CHANGES TO THE EUT BY THE LAB

No any modifications are made to the EUT by the lab during the test.

--- END ---