

AR5BAP-00032 Access Point User's Guide

Revision Oct 2006



ATHEROS[®]
COMMUNICATIONS

© 2003–2004 by Atheros Communications, Inc. All rights reserved.

ATHEROS™, 5-UP™, Driving the Wireless Future™, Atheros Driven™, Atheros™, and the Air is Cleaner at 5-GHz™ are trademarks of Atheros Communications, Inc. The Atheros logo is a registered trademark of Atheros Communications, Inc. All other trademarks are the property of their respective holders.

Subject to change without notice.

Notice

The information in this document has been carefully reviewed and is believed to be accurate. Nonetheless, this document is subject to change without notice, and Atheros Communications, Inc. (Atheros) assumes no responsibility for any inaccuracies that may be contained in this document, and makes no commitment to update or to keep current the contained information, or to notify a person or organization of any updates. Atheros reserves the right to make changes, at any time, in order to improve reliability, function or design and to attempt to supply the best product possible. Atheros does not represent that products described herein are free from patent infringement or from any other third party right.

No part of this document may be reproduced, adapted or transmitted in any form or by any means, electronic or mechanical, for any purpose, except as expressly set forth in a written agreement signed by Atheros. Atheros or its affiliates may have patents or pending patent applications, trademarks, copyrights, maskwork rights or other intellectual property rights that apply to the ideas, material and information expressed herein. No license to such rights is provided except as expressly set forth in a written agreement signed by Atheros.

ATHEROS MAKES NO WARRANTIES OF ANY KIND WITH REGARD TO THE CONTENT OF THIS DOCUMENT. IN NO EVENT SHALL ATHEROS BE LIABLE FOR DIRECT, INDIRECT, SPECIAL, INCIDENTAL SPECULATORY OR CONSEQUENTIAL DAMAGES ARISING FROM THE USE OR INABILITY TO USE THIS PRODUCT OR DOCUMENTATION, EVEN IF ADVISED OF THE POSSIBILITY OF SUCH DAMAGES. IN PARTICULAR, ATHEROS SHALL NOT HAVE LIABILITY FOR ANY HARDWARE, SOFTWARE, OR DATA TRANSMITTED OR OTHERWISE USED WITH THE PRODUCT, INCLUDING THE COSTS OF REPAIRING, REPLACING, INTEGRATING, INSTALLING OR RECOVERING SUCH HARDWARE, SOFTWARE OR DATA. ATHEROS SPECIFICALLY DISCLAIMS THE IMPLIED WARRANTIES OF MERCHANTABILITY AND FITNESS FOR A PARTICULAR PURPOSE AS THEY MIGHT OTHERWISE APPLY TO THIS DOCUMENT AND TO THE IDEAS, MATERIAL AND INFORMATION EXPRESSED HEREIN.

Document Number: 984-00023-003

Document Conventions

Text Conventions

bold Bold type within paragraph text indicates commands, file names, directory names, paths, output, or returned values.

Example: The DK_Client package will not function unless the **wdreg_install** batchfile is used.

italic Within commands, italics indicate a variable that the user must specify.

Example: **mem_alloc** *size_in_bytes*

Titles of manuals or other published documents are also set in italics.

Courier The Courier font indicates output or display.

Example: Error: Unable to allocate memory for transfer!

[] Within commands, items enclosed in square brackets are optional parameters or values that the user can choose to specify or omit.

{ } Within commands, items enclosed in braces are options from which the user must choose.

| Within commands, the vertical bar separates options.

... An ellipsis indicates a repetition of the preceding parameter.

> The right angle bracket separates successive menu selections.

Example: Start > Programs > DK > wdreg_install.

Notices

NOTE: This message denotes neutral or positive information that calls out important points to the text. A note provides information that may apply only in special cases.

CAUTION: Cautions call special attention to hazards that can cause system damage or data corruption, to a lesser degree than warnings.

WARNING: Warnings call special attention to hazards that can cause system damage, data corruption, personal injury, or death.

Contents

List of Figures	vii
List of Tables	ix
Preface	xi
About this Document	xi
1 Introduction	1-1
System Requirements	1-1
2 AP Network Attachment and Configuration	2-1
AP Network Connections	2-1
Network Configuration	2-2
AP Hardware Configuration	2-5
AP Initial Configuration	2-6
Web Browser	2-6
Command-Line Interface	2-10
A AP Web Server	A-1
Accessing the AP Web Server	A-1
Configuration Windows	A-5
Working with Configuration Windows	A-6
System Configuration Window	A-7
5 GHz Radio Configuration Window	A-9
5GHz Security Configuration Window	A-11
Edit Security Server Settings	A-12
5 GHz 802.1X Configuration	A-14
5 GHz Access Control List Configuration Window	A-15
Adding New Access Control Lists	A-16
Adding Access Control List Permissions	A-18

5 GHz Radio Advanced Configuration Window	A-19
2.4 GHz Radio Configuration Window	A-21
2.4 GHz Security Configuration Window.	A-23
Edit Security Server Settings.	A-25
2.4 GHz 802.1X Configuration	A-26
2.4 GHz Access Control List Configuration Window	A-27
Adding New Access Control Lists	A-28
Adding Access Control List Permissions	A-29
2.4 GHz Radio Advanced Configuration Window	A-30
Script Configuration Window	A-32
Firmware Update Configuration Window	A-33
Statistics Windows	A-35
AP Statistics	A-35
Station Statistics	A-37
B Regulatory Compliance Information	B-1
FCC Requirements for Operation in the Unites States.	B-2
Radio Frequency Interference Warnings & Instructions.	B-2
RF Exposure	B-3
Declaration Of Conformity.	B-3

DO NOT COPY

List of Figures

Figure 2-1.	Access Point to HPC Connections.	2-2
Figure 2-2.	AP Physical Description	2-5
Figure 2-3.	AP Web Server Homepage.	2-7
Figure 2-4.	5 GHz Statistics Window.	2-8
Figure 2-5.	System Configuration Window	2-9
Figure A-1.	AP Web Server Homepage.	A-2
Figure A-2.	5 GHz Statistics Window.	A-4
Figure A-3.	AP Web Server Navigation Bar	A-5
Figure A-4.	AP System Configuration Window	A-7
Figure A-5.	5 GHz Radio Configuration Window.	A-9
Figure A-6.	AP 5 GHZ Security Configuration Window	A-11
Figure A-7.	5 GHz RADIUS Server Configuration Window	A-13
Figure A-8.	5 GHz Access Control List Configuration Window	A-15
Figure A-9.	5 GHz New Access Control List Configuration Window.	A-16
Figure A-10.	5 GHz Security Edit ACL Configuration Window	A-18
Figure A-11.	5 GHz Radio Advanced Configuration Window	A-19
Figure A-12.	2.4 GHz Radio Configuration Window.	A-21
Figure A-13.	2.4 GHZ Security Configuration Window	A-23
Figure A-14.	2.4 GHz RADIUS Server Configuration Window	A-25
Figure A-15.	2.4 GHz Access Control List Configuration Window	A-27
Figure A-16.	2.4 GHz New Access Control List Configuration Window.	A-28
Figure A-17.	2.4 GHz Security Edit ACL Configuration Window	A-29
Figure A-18.	2.4 GHz Radio Advanced Configuration Window	A-30
Figure A-19.	Configuration Script Configuration Window	A-32
Figure A-20.	AP Firmware Update Configuration Window.	A-33
Figure A-21.	Advanced Firmware Update Configuration Window	A-34
Figure A-22.	Basic Service Set Statistics Window for an AP.	A-35
Figure A-23.	Basic Service Set Statistics Window for Station	A-37

List of Tables

Table 2-1.	Ethernet Port Configuration	2-5
Table A-1.	Homepage .GIF Files.	A-2
Table A-2.	System Configuration Window Field Descriptions.	A-8
Table A-3.	5 GHz Radio Configuration Window Field Descriptions . .	A-10
Table A-4.	5 GHz Security Field Descriptions	A-12
Table A-5.	RADIUS Server Configuration Field Descriptions	A-13
Table A-6.	5 GHz New Access Control List Field Descriptions	A-16
Table A-7.	5 GHz Edit Access Control List Field Descriptions.	A-18
Table A-8.	5 GHz Radio Advanced Configuration Window Field Descriptions A-20	
Table A-9.	2.4 GHz Radio Configuration Window Field Descriptions .	A-22
Table A-10.	2.4 GHz Security Field Descriptions	A-24
Table A-11.	2.4 GHz RADIUS Server Configuration Field Descriptions .	A-25
Table A-12.	2.4 GHz New Access Control List Field Descriptions	A-28
Table A-13.	2.4 GHz Security Edit Access Control List Field Descriptions	A- 29
Table A-14.	2.4 GHz Radio Advanced Configuration Window Field Descriptions A-31	
Table A-15.	BSS Stats Field for AP Descriptions	A-36
Table A-16.	BSS Stats Fields for STA Descriptions	A-38

Preface

The intent of this document is to familiarize users with the Atheros AR5BAP-00032 Access Point (AP), its setup, configuration, and usage. After reading this user's guide, the user should be able to install, configure, control, and maintain the Atheros Access Point.

About this Document

The document consists of the following chapters and appendices:

Chapter 1 **Introduction**—Describes the Access Point package contents and system requirements.

Chapter 2 **AP Network Attachment and Configuration**—Describes the Access Point network connections and initial software configuration.

Appendix A **AP Web Server**—Describes the use of the web server to configure the Access Point.

Appendix B **Regulatory Compliance Information**—Important user information and instructions concerning operating this device in accordance with National spectrum usage laws for radio devices.

1

Introduction

The Atheros Access Point implements an IEEE 802.11a/b/g wireless LAN (WLAN) AP or data-oriented Residential Gateway (RG) supporting up to 256 station associations. Rates of 6 to 54 Mbps are supported in standard IEEE 802.11a/g modes and up to 11 Mbps in 802.11b mode.

System Requirements

The AP contains a small boot executive that allows the main operating system software to be downloaded using the Ethernet port over an FTP connection. The Operating system software can also reside in the Flash memory of the AP, which allows booting without the need to download the operating system from the host PC over an FTP connection. A configuration file is created in Flash memory to store user-configurable parameters such as WEP keys. A terminal or PC with an Ethernet connection is required to perform the initial AP configuration. An FTP server is required for firmware update to the AP.

Use the AP Web Server for firmware updates. Refer to Appendix A, [“Firmware Update Configuration Window”](#) for information on the web server.

2

AP Network Attachment and Configuration

This section provides procedures for connecting and configuring the AP to a Host PC (HPC). Configuration can be performed either from a web browser accessing the built-in web server, or by entering command using the command line interface (CLI). For detailed information on using the web server, refer to [“AP Web Server”](#) in Appendix A. For detailed information on using CLI, refer to [“AP Command-Line Interface”](#) in Appendix B. For [“Factory Default Settings”](#) refer to Appendix B.

AP Network Connections

Connect the HPC to the AP using one of the following two methods:

- Use an Ethernet crossover cable (not supplied) to connect directly to the Ethernet port of the HPC. For more information on Ethernet cables, see [Table 2-1](#).
- Use standard Ethernet cables (not supplied) to connect through a hub or Ethernet switch.

See [Figure 2-1](#) for an example of the AP to the HPC connections.

Follow these steps to establish the network connections:

1. Connect the AP Ethernet port to the HPC Ethernet card through the Ethernet hub/switch or an Ethernet crossover cable.

2. Connect the optional RS-232 port to the HPC serial port through a serial cable. Refer to [Appendix C](#) for more information on the serial interface.
3. Plug in the provided power supply to the AP power supply connector.

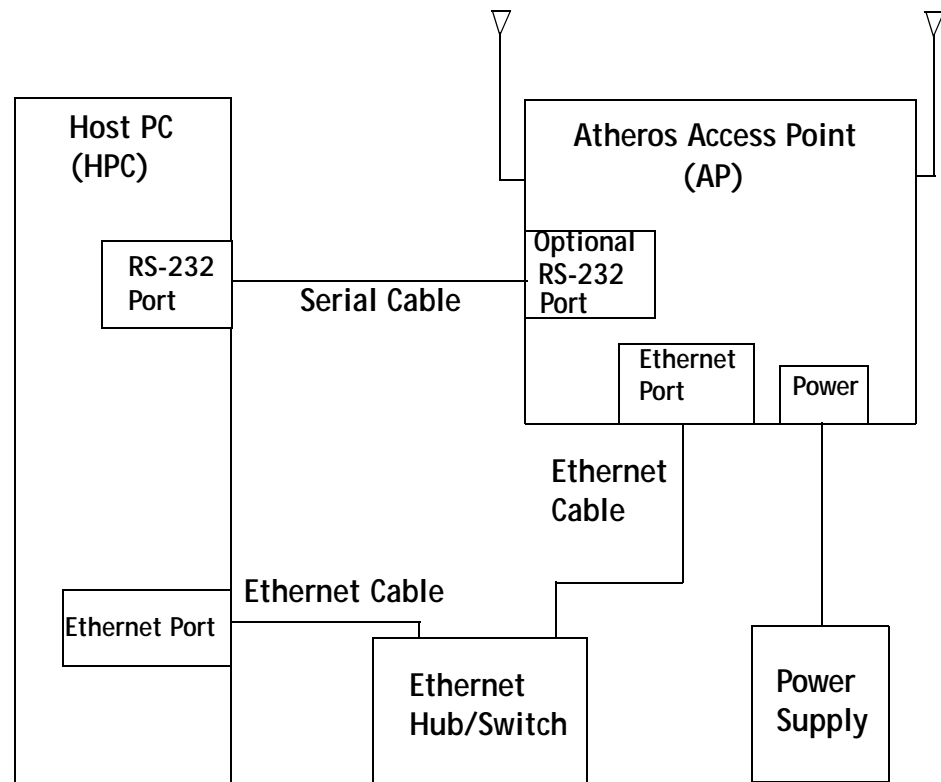

Figure 2-1. Access Point to HPC Connections

Network Configuration

Follow these steps to configure the HPC for AP network control:

1. From the HPC's Start menu, choose Settings and open the Network and Dial-up Connections dialog box.
2. Right-click on the Local Area Connection icon that belongs to the Ethernet controller connected to the AP, and select Properties.

3. Within the Local Area Connection Properties dialog box, choose Internet Protocol (TCP/IP) and click Properties.

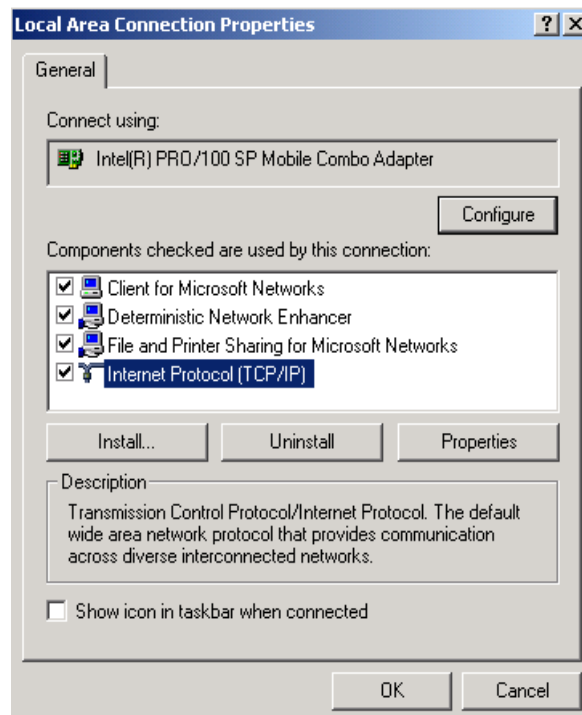

4. Configure the IP address for the Ethernet connection in the Internet Protocol (TCP/IP) Properties dialog box.

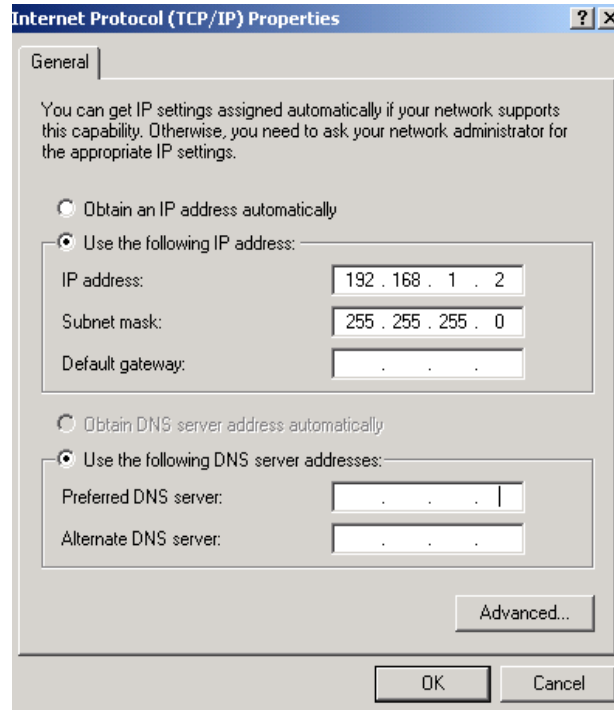

5. Click OK to continue and close the Internet Protocol Properties dialog box.

AP Hardware Configuration

The Atheros AP hardware allows the configuration of one or two WLANs. [Figure 2-2](#) shows the physical location of WLAN, panel connectors on the AP hardware, and the location of the antennae cables. [Table 2-1](#) summarizes the type of cable to use when using the Ethernet wired ports on the AP. You may use either, or both Ethernet ports.

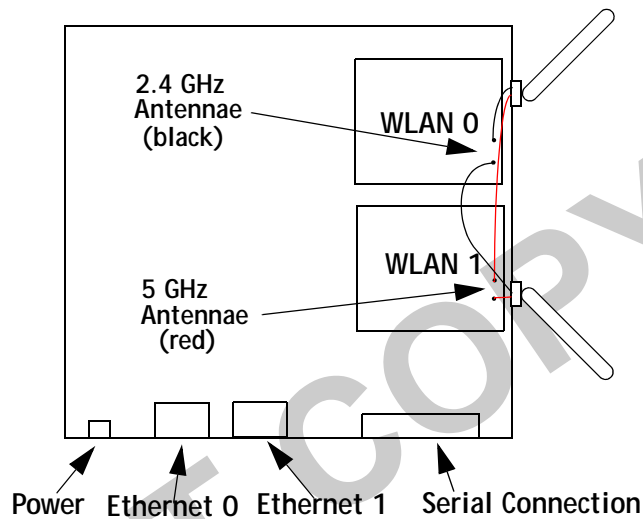

Figure 2-2. AP Physical Description

Table 2-1. Ethernet Port Configuration

Ethernet Port Number	Dumb Hub or Switch	Computer	Auto-Sensing Hub or Switch
0	Crossover cable	Straight cable	Crossover or straight cable
1	Straight cable	Crossover cable	Crossover or straight cable

AP Initial Configuration

This section describes how to configure the AP after booting from Flash memory. Refer to “[Firmware Update Configuration Window](#)” on [page A-33](#) to load the Operating image file to the Flash file system, if the operating system software should be updated.

Configure the AP for its channel frequency and Service Set Identifier (SSID) unique to the application. This configuration can be done either through a web browser with access to the built-in AP web server, or by issuing commands through the command line interface (CLI).

The AP can be configured at any time to tailor it for the application environment. For more information on configuring the AP using the web browser, refer to “[AP Web Server](#)” in Appendix A. For more information on using the CLI, refer to “[AP Command-Line Interface](#)” in Appendix B.

The following description illustrates the use of the web browser. For information on using the CLI, refer to “[Command-Line Interface](#)” on [page 2-10](#).

Web Browser

Follow these steps to configure the channel frequency and SSID using a web browser:

1. Launch a web browser (Netscape Navigator or Internet Explorer are examples of commonly used web browsers).
2. From the HPC, enter the IP address that is assigned to the AP as the URL address, for example `http://192.168.1.1`.

The Access Point Web Server homepage will appear (see [Figure 2-3](#)).

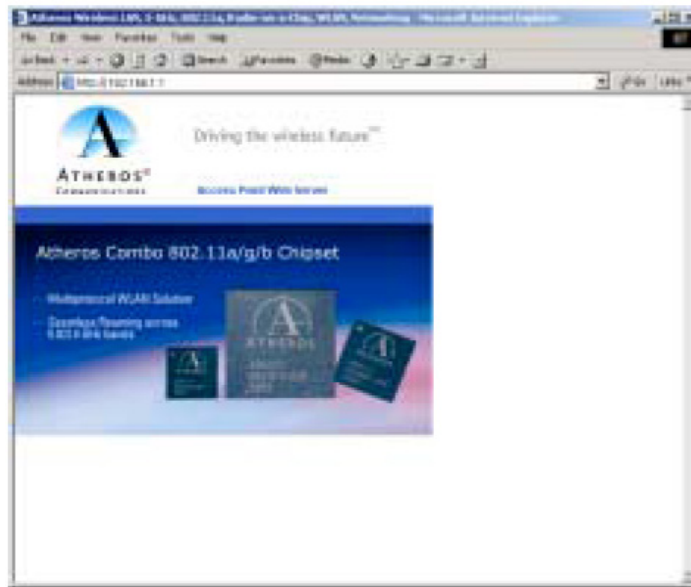
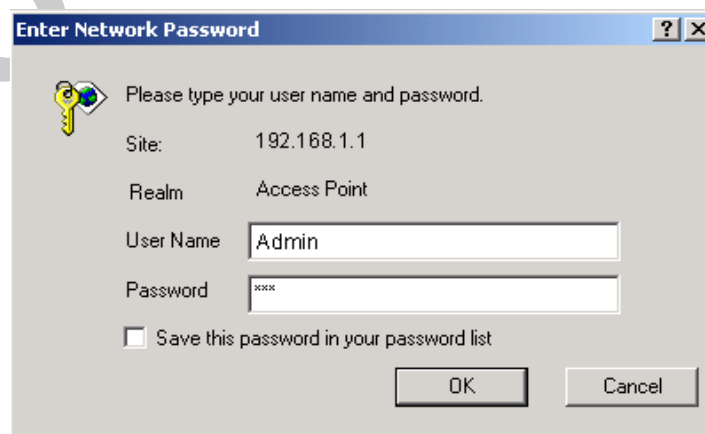

Figure 2-3. AP Web Server Homepage

3. Select the Access Point Web Server hotlink.
4. A dialog box appears requesting login authorization. When prompted, enter the following information to log in:

Log in: **Admin** (case-sensitive)

Password: **5up**



5. Click OK to complete the login process. The 5 GHz Statistics window appears (see [Figure 2-4](#)).

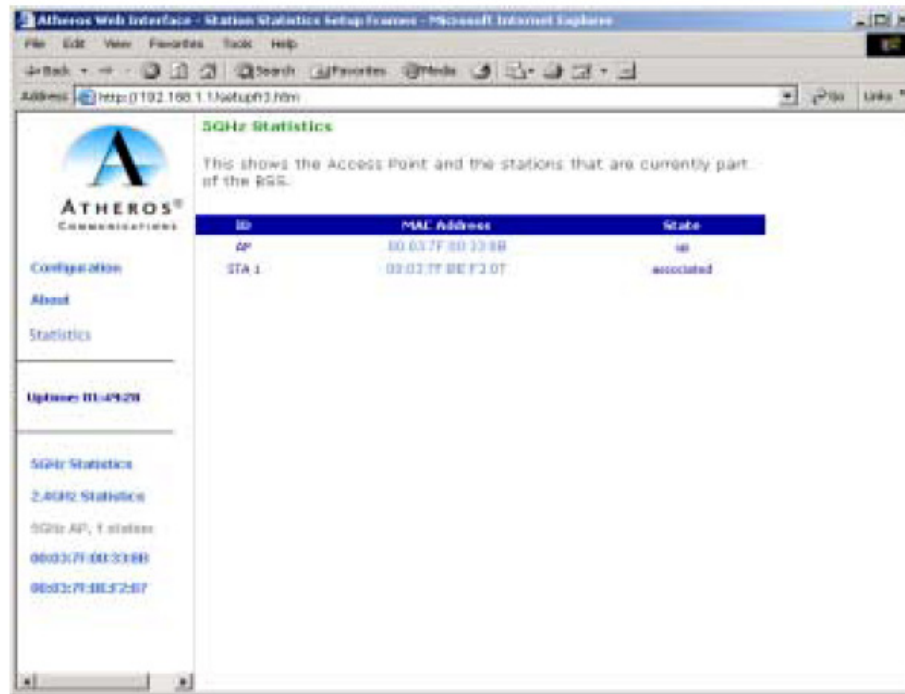

Figure 2-4. 5 GHz Statistics Window

6. Select the Configuration hotlink from the navigation menu.

The System Configuration window appears (see [Figure 2-5](#)).

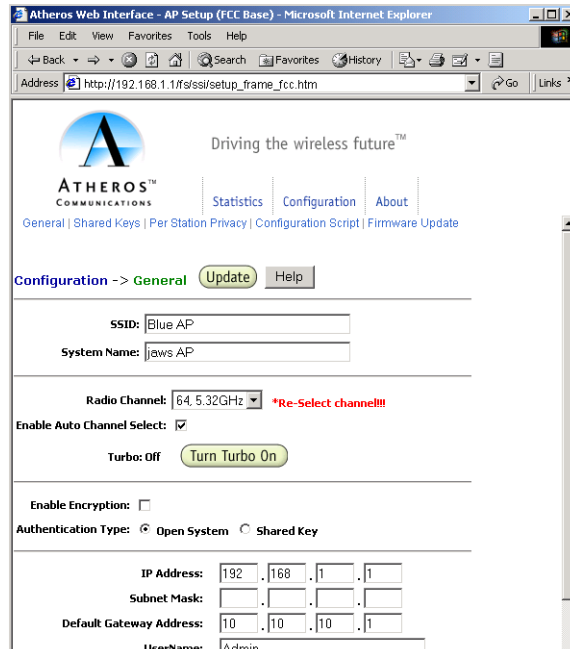

Figure 2-5. System Configuration Window

7. Enter the SSID (name or address) for the AP in the SSID field. The SSID must be 1–32 characters in length.

To configure a single SSID to have more than one AP in a single SSID, specify a unique System Name for each AP within that single SSID.

Note that range of available channels will be automatically determined by factory settings.

Note that the radio channel is specified using the IEEE 802.11a standard. For example, channel 48 is the equivalent of 5.240 GHz. The formula below shows how the channel number is derived:

$$\text{Channel Number} = \frac{\text{Channel Frequency (in MHz)} - 5000 \text{ MHz}}{5 \text{ MHz}}$$

- Click Update to commit the changes.



Change other settings at this time. Refer to [Appendix A](#) for more information about each configuration option.

- After all configuration changes are complete, reboot the AP to enable them. To reboot the AP, click on the REBOOT AP button that appears.

Reminder: Click the  button for changes to take effect

Command-Line Interface

The following procedures show the steps required to configure the AP SSID and channel frequency (where allowed) using the command-line (CLI) interface and Telnet.

After the AP boots and the operating system software loads, use Telnet to access the AP through the default AP IP address as follows:

- Select Start > Run from the Microsoft Win2K tool bar.
- Type **cmd** in the Open dialog box and click OK.
- In the command line prompt, type **telnet 192.168.1.20** and press the Enter key.
- When prompted, enter the following information to log in:

Username: **Admin** (case sensitive)

Password: **5up**
- Press Enter to complete the login process. The Atheros Access Point Software revision prompt appears:

```
Atheros Access Point Rev. X.Y.Z
```
- Use the **set ssid <SSID>** command to specify the SSID.
- Use the **set channel <channel>** command to change the radio channel.
- Use the **reboot** command and then press Enter, which reboots the AP, to enable any changes.
- To view CLI command options, use the **help** command or refer to [Appendix B](#) for details about CLI options.

A

AP Web Server

Configure the access point (AP) either through a web browser interface to the AP web server, or using the command-line interface (CLI) through telnet. The web server resides in the AP and is accessible from any station (STA) that is connected to the AP Infrastructure network.

This appendix describes configuring the AP through the AP Web Server.

Accessing the AP Web Server

Follow these steps to access the AP Web Server:

1. Launch a web browser (Netscape Navigator or Internet Explorer are examples of commonly used web browsers).
2. From the HPC, enter the IP address that is assigned to the AP as the URL address. For example, enter `http://192.168.1.1`.

The Access Point Web Server homepage appears (see [Figure A-1](#)).

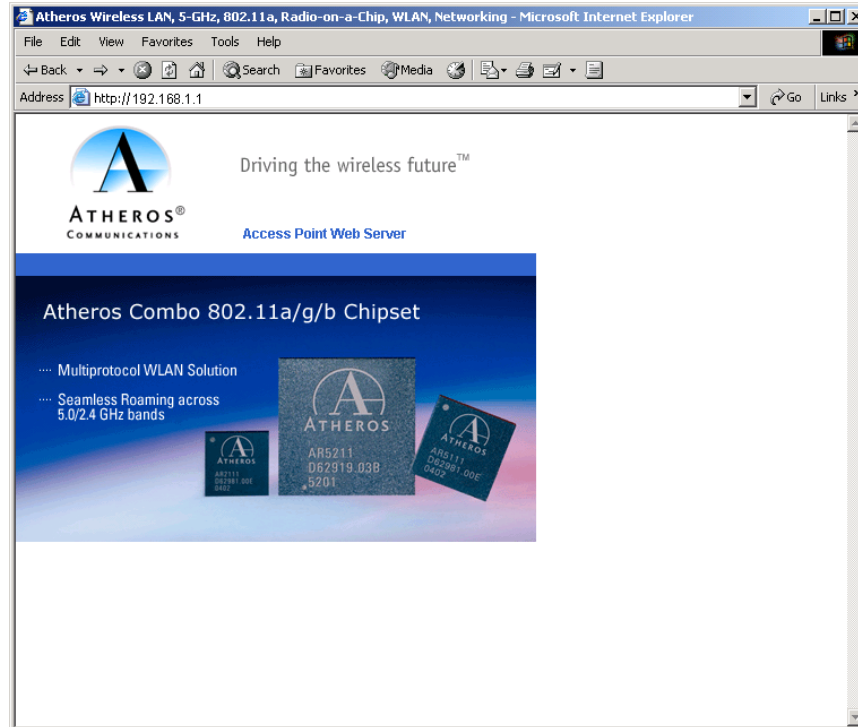

Figure A-1. AP Web Server Homepage

Customize the appearance of the Access Point Web Server homepage by replacing any of the three .GIF files used on the page. Use FTP to store the replacement .GIF files to the AP. [Table A-1](#) summarizes the three .GIF files to replace to customize the homepage.

Table A-1. Homepage .GIF Files

Filename	Description
logo.gif	Replaces the current Atheros logo with another .GIF file.
tagline.gif	Replaces the tagline “Driving the wireless future” with a new tagline.
cover.jpg	Replaces the Atheros AR5001AP chipset photograph with a new photograph.

For example, the .GIF file containing the full path filename for a company logo can be replaced with another .GIF file.

3. Select the Atheros Access Point Web Server hotlink.

4. A dialog box appears requesting login authorization. When prompted, enter the following information to log in:

Log in: **Admin** (case sensitive)

Password: **5up**

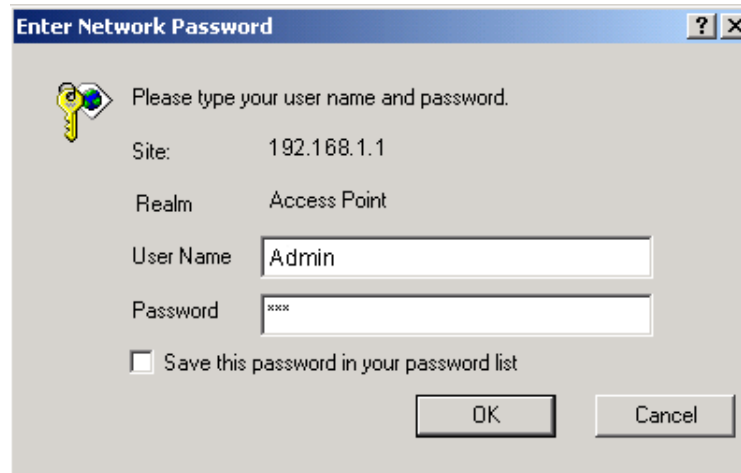

5. Click OK to complete the login process.

NOTE: The web browser must support frames and Java script must be enabled.

The Access Point Web Server 5 GHz Statistics window appears (see [Figure A-2.](#))

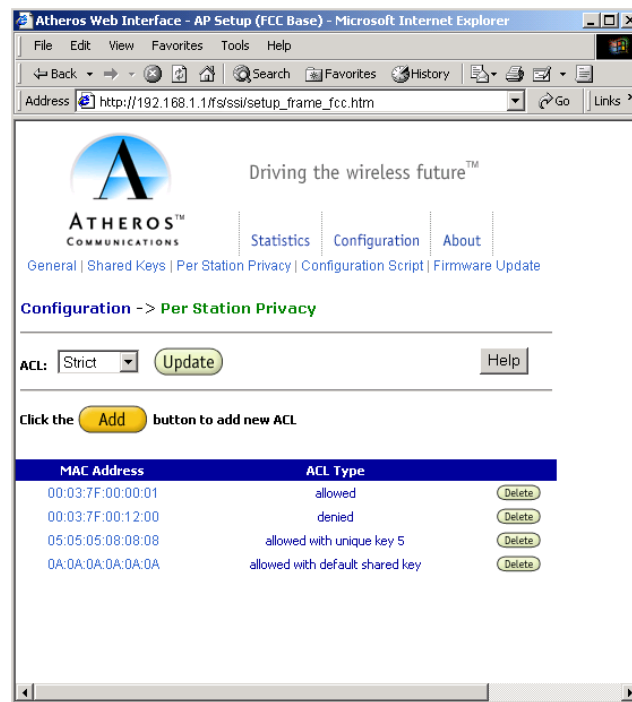

Figure A-2. 5 GHz Statistics Window

Configuration Windows

The Web Server Configuration windows allow viewing and editing of configuration information for the AP. The Web Server provides configuration windows for:

- System configuration parameters
- 5 GHz and 2.4 GHz radio configuration parameters
- 5 GHz/2.4 GHz statistics
- Security
- Configuration scripts
- Firmware updates

To access any of these AP configuration screens, click on the desired hotlink from the navigation bar on any configuration screen (see [Figure A-3](#).)

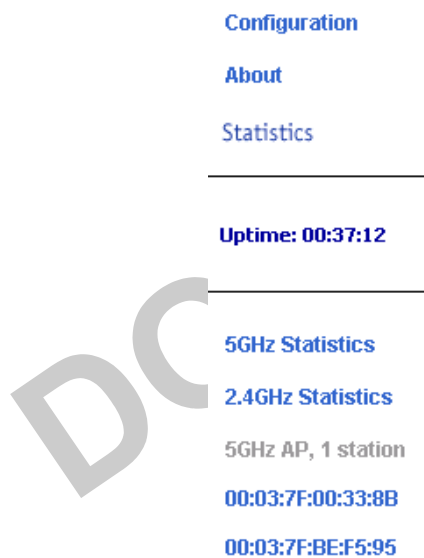

Figure A-3. AP Web Server Navigation Bar

Working with Configuration Windows

The Web Server Configuration windows provide a user-friendly interface to aid in quick configuration of the AP. After making any additions or changes to any configuration window, update the configuration file to save the changes. The new configuration is not in effect until the AP is rebooted.

Follow these steps to update configuration files:

1. Enter the configuration updates or changes in the appropriate configuration fields.
2. Click Update.

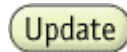

3. Click Reboot AP to make the changes effective.

Reminder: Click the  button for changes to take effect

The web server loses connectivity with the Web Server as the AP reboots.

To reestablish the connection with the Web Server, wait until the AP has completed rebooting and navigate to the Web Server to resume communication.

System Configuration Window

The System Configuration window allows the setting of general operating information for the AP. Click on Configuration from any window to access the System Configuration window (see [Figure A-4](#)).

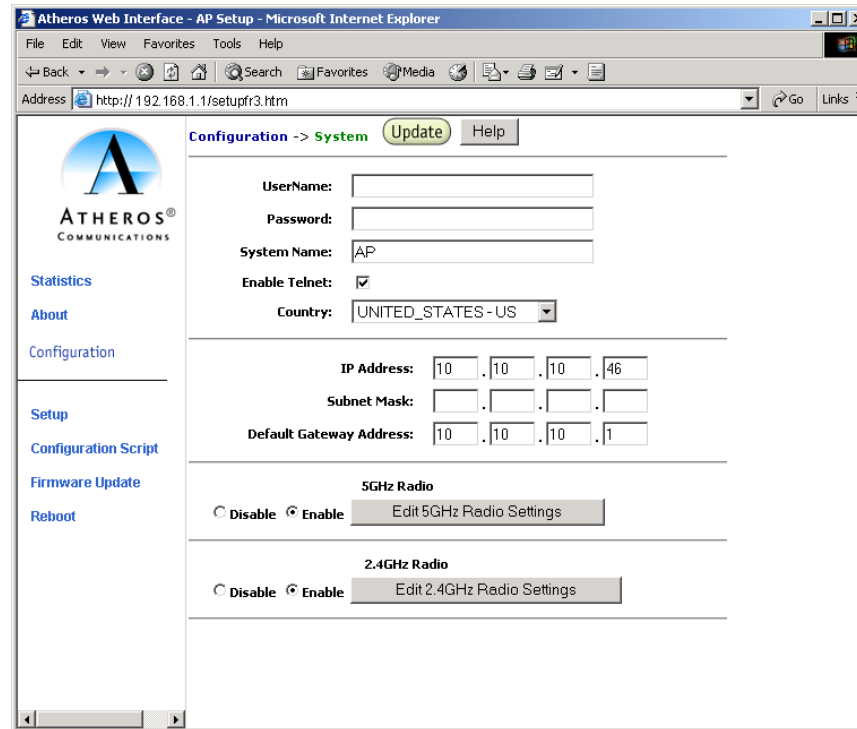

Figure A-4. AP System Configuration Window

Other settings can also be changed at this time.

Table A-2 summarizes the data fields on the System Configuration window.

Table A-2. System Configuration Window Field Descriptions

General Configuration Field	Description
User Name	Specifies the user name.
Password	Specifies the password.
System Name	Specifies a unique name for AP. Enter a unique text string of up to 32 characters in length.
Enable Telnet	Use the checkbox to allow telneting into the AP.
Country	Specifies the country where the AP is operating. Use the drop-down menu to specify the country where the equipment will operate from. The allowable choices may be limited by firmware installed on your version of the product depending on Regulatory Domain (country) of operation.
IP Address	Specifies the IP address of the AP.
Subnet Mask	Specifies the subnet mask for the AP.
Default Gateway Address	Specifies the default gateway for the AP.
5 GHz Radio	Use the radio buttons to enable/disable 5 GHz radio operation.
2.4 GHz Radio	Use the radio buttons to enable/disable 2.4 GHz radio operation.
Edit 5 GHz Radio Settings	Click this button to edit the configuration for 5 GHz radio operation (refer to “5 GHz Radio Configuration Window” on page A-9).
Edit 2.4 GHz Radio Settings	Click this button to edit the configuration for 2.4 GHz radio operation. (refer to “2.4 GHz Radio Configuration Window” on page A-21).

5 GHz Radio Configuration Window

The 5 GHz Radio Configuration window allows the setting of generic 5 GHz radio operating information for the AP. The device's factory configured firmware limits the available settings. From the AP System Configuration window, click on Edit 5 GHz Radio Settings to access the 5 GHz Radio Configuration window (see [Figure A-5](#)).

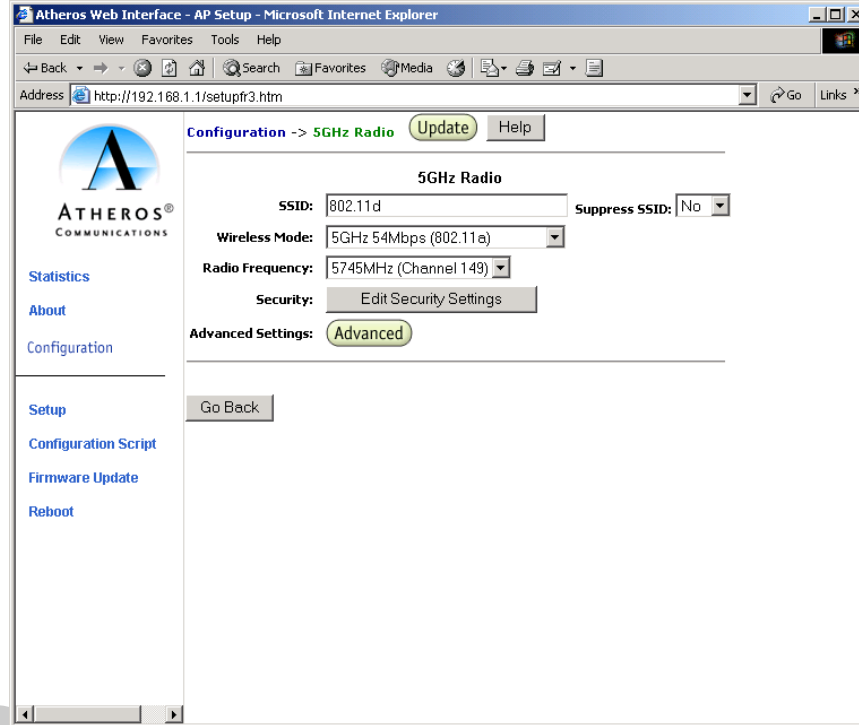

Figure A-5. 5 GHz Radio Configuration Window

[Table A-3](#) summarizes the data fields on the 5 GHz Radio Configuration window.

Table A-3. 5 GHz Radio Configuration Window Field Descriptions

General Configuration Field	Description
SSID	Identification of the AP. Enter a number or address between 1 and 32 characters in length that the STAs are associating with in Infrastructure mode. More than one AP in an SSID can be specified here. Use the System Name field to uniquely identify each AP.
Suppress SSID	Use the checkbox to prevent broadcast of the AP's SSID in beacons. When enabled, the SSID in beacons are not transmitted and only those STAs with prior knowledge of an AP's SSID can associate with that AP.
Wireless Mode	The wireless LAN mode specifies both frequency range and data rates.
Radio Frequency (MHz)	Select the desired frequency of operation from the drop-down menu, or choose SmartSelect. The radio frequencies that appear in the Radio Channel drop-down menu are limited by the factory configured firmware.
Edit Security Settings	Click here to edit the security configuration for 5 GHz radio operation.
Advanced Settings	Click here to enter advanced configuration for 5 GHz radio operation.

5GHz Security Configuration Window

The 5 GHz Radio Security Configuration window allows the setting of security information for the AP for 5 GHz operation. From the 5 GHz Radio Configuration window, click on Edit Security Settings to access the 5 GHz Security Configuration window (see [Figure A-6](#)).

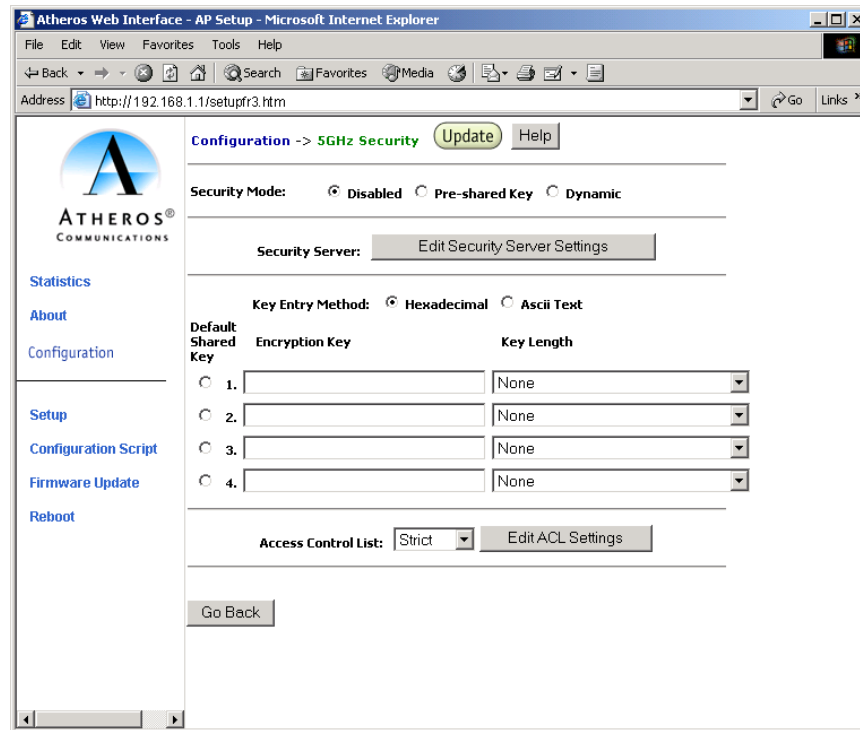

Figure A-6. AP 5 GHz Security Configuration Window

Table A-4 summarizes the data fields on the 5 GHz Security Configuration window.

Table A-4. 5 GHz Security Field Descriptions

Security Configuration Field	Description
Security Mode	Use the radio buttons to specify the security mode.
Security Server	Click Edit Security Server Settings to change the configuration of the security server.
Key Entry Method	Use the radio buttons to specify the key entry method as either hexadecimal or ASCII.
Default Shared Key	Use the radio button to specify which encryption key to use as the default shared key.
Encryption Key	Specifies the encryption key used for broadcast/multicast frames.
Key Length	Specifies the key length: <ul style="list-style-type: none"> ■ None ■ 10 Hex digits or 5 ASCII text ■ 26 Hex digits or 13 ASCII text ■ 32 Hex digits or 16 ASCII text
Edit ACL Settings	Click here to edit the configuration of the ACL operation for 5 GHz.
Access Control List	Specifies the state of the Access Control List (ACL). Use the drop-down menu to specify the state of ACL, where: <ul style="list-style-type: none"> ■ Disable—Unrestricted Access: By default, while checking of the ACL is enabled, the access control list itself is empty. This is the same as disabling the checking on the ACL. ■ Enable—Restricted Access: An ACL entry must exist before ACL can be enabled. While ACL is enabled, stations with valid shared keys and stations with matching “allow” entries on the ACL are authenticated. ■ Strict—Restricted (w/ACL match): Requires an ACL entry that specifies the station's assigned unique key or the station is denied association. In the strict mode, stations with valid share keys and not on the ACL are not authenticated. The stations must have unique keys defined and matching “allow” ACL entries specified, in order to associate with the AP.

Edit Security Server Settings

The RADIUS Server Configuration window allows configuration of a RADIUS server for authentication purposes in 802.1X networks. See

Figure A-7 for an illustration of the 5 GHz RADIUS Server Configuration window.

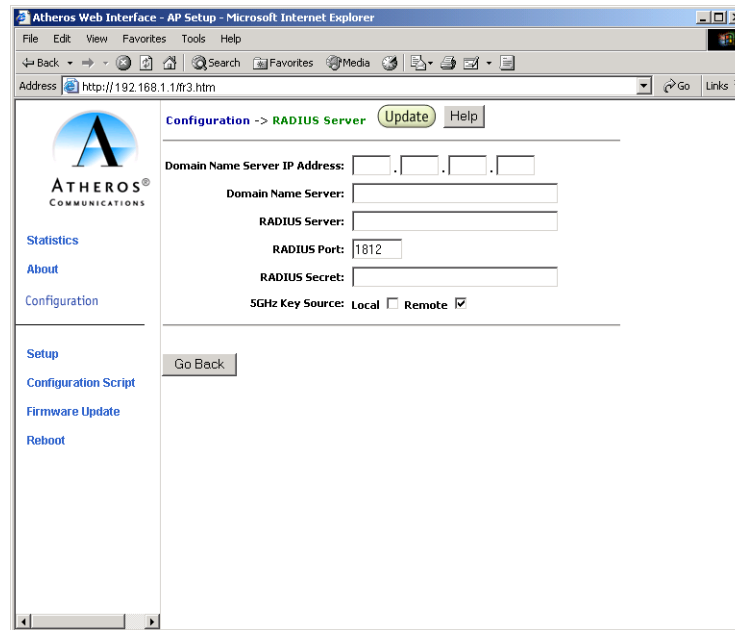

Figure A-7. 5 GHz RADIUS Server Configuration Window

Table A-5 summarizes the data fields on the RADIUS Server Configuration window.

Table A-5. RADIUS Server Configuration Field Descriptions

Security Configuration Field	Description
Domain Name Server IP Address	Specifies the IP address of the domain name server.
Domain Name Server	Specifies the name of the domain name server.
RADIUS Server	Specifies the IP address of the RADIUS server.
RADIUS Port	Specifies the port of the RADIUS server.
RADIUS Secret	Specifies the password for the RADIUS server.
RADIUS Key Source	Specifies the location of the RADIUS keys. Use the "local" checkbox to specify the RADIUS keys are located in the AP. Use the "remote" checkbox to specify the RADIUS keys are located in the RADIUS server.

5 GHz 802.1X Configuration

The IEEE 802.1X protocol is designed to support port-based authentication and secure key distribution. It can be used to distribute unique encryption keys for an entire BSS. Atheros provides support for this protocol on both the AP and the STA.

To enable 802.1X on the AP, take the following steps on the 5 GHz RADIUS Server Configuration window:

1. Specify the domain name server IP address.
2. Specify the name of the domain server.
3. Specify a RADIUS Server name.
4. Specify a RADIUS Server secret.
5. Specify the location of the 5 GHz Key Source as *Remote*.

DO NOT COPY

5 GHz Access Control List Configuration Window

The 5 GHz Radio Configuration window allows the setting of security information for the AP. From the 5 GHz Security Configuration window, click on Edit ACL Settings to access the 5 GHz ACL Configuration window (see [Figure A-8](#)).

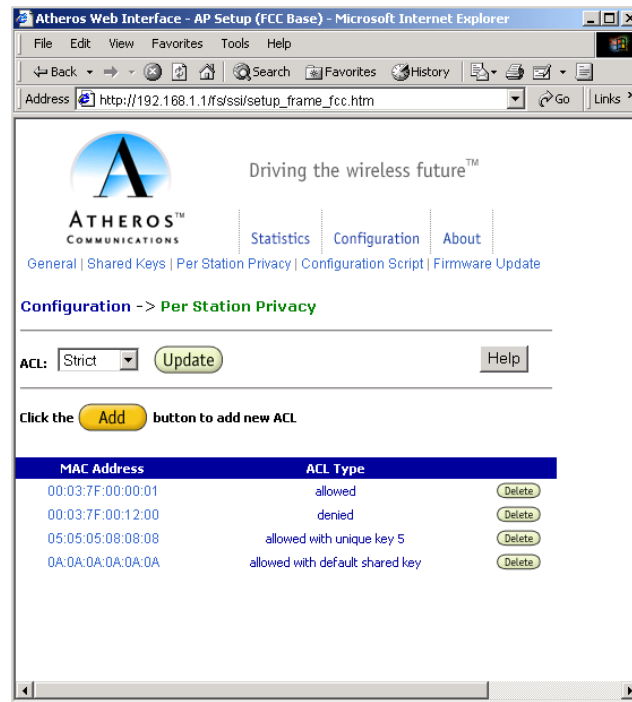

Figure A-8. 5 GHz Access Control List Configuration Window

Click Delete to remove any list item.

Adding New Access Control Lists

The 5 GHz Security New ACL Configuration window allows you to add new access control list item. From the 5 GHz ACL Configuration window, click Add to list to enter new list items (see [Figure A-9](#)).

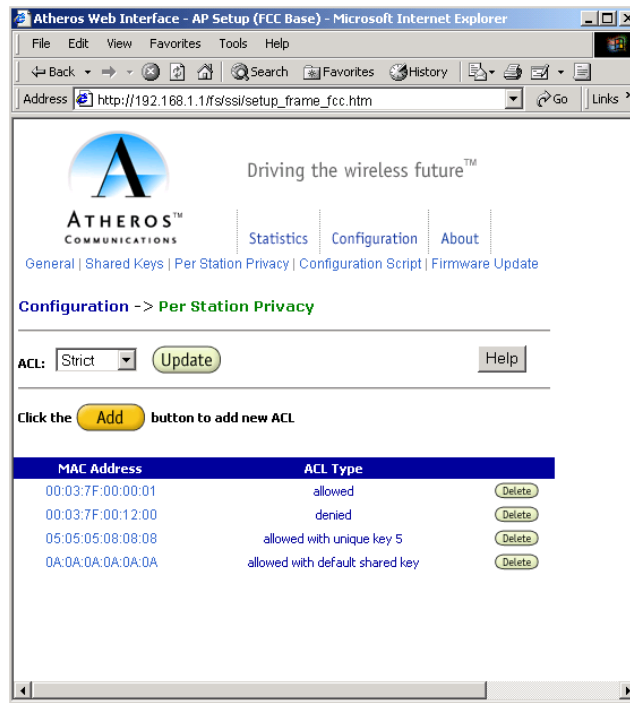

Figure A-9. 5 GHz New Access Control List Configuration Window

[Table A-6](#) summarizes the data fields on the New ACL Configuration window.

Table A-6. 5 GHz New Access Control List Field Descriptions

Per Station Privacy Field	Description
MAC Address	Specifies the MAC address for the STA to be included in the ACL.
ACL Type	Specifies the current state of each STA, where: <ul style="list-style-type: none"> ■ Allowed—Enable access for this MAC address to the ACL. ■ Denied—Deny access for this MAC address to the ACL. ■ Default Shared Key—This MAC address would use the default shared key. ■ 64/128/152 Bits—Specifies lengths for shared keys.
Unique Key	Enter a unique key.

Follow these steps to add new items to the Access Control List:

1. Specify the ACL type from the drop-down menu.

The Access Control List (ACL) allows an administrator to perform security actions based on the client station MAC address. Use this selection to allow or deny association with the AP and for unique per station WEP key assignment.

2. Enter the MAC address for the STA to be included on the access list.
3. Enter a unique key for the new list item.
4. Click Add to List.

Once entered in the ACL Control List, click on Delete to remove any configured STA from the access list.

Click Update to save changes.

Adding Access Control List Permissions

The 5 GHz ACL Configuration window allows you to add permission for each list item. From the 5 GHz ACL Configuration window, click on a MAC address in the list to view the 5 GHz Security Edit ACL Configuration window (see [Figure A-10](#)).

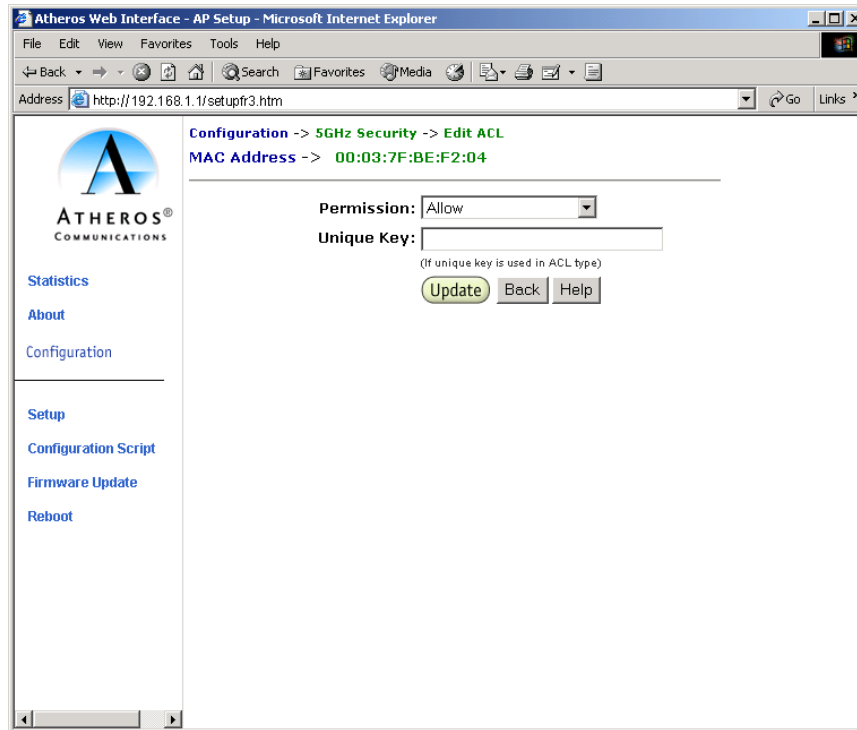

Figure A-10. 5 GHz Security Edit ACL Configuration Window

[Table A-7](#) summarizes the data fields on the 5 GHz Security Edit ACL window

Table A-7. 5 GHz Edit Access Control List Field Descriptions

Per Station Privacy Field	Description
Permission	<p>Specifies the current state of each STA, where:</p> <ul style="list-style-type: none"> ■ Allowed—Enable access for this MAC address to the ACL. ■ Denied—Deny access for this MAC address to the ACL. ■ Default Shared Key—This MAC address would use the default shared key. ■ 64/128/152 Bits—Specifies lengths for shared keys
Unique Key	Enter a unique key.

5 GHz Radio Advanced Configuration Window

The 5 GHz Radio Advanced Configuration window allows the setting of 5 GHz advanced, radio operating information for the AP. From the 5 GHz Radio Configuration window, click on Advanced to access the 5 GHz Radio Advanced Configuration window (see [Figure A-11](#)).

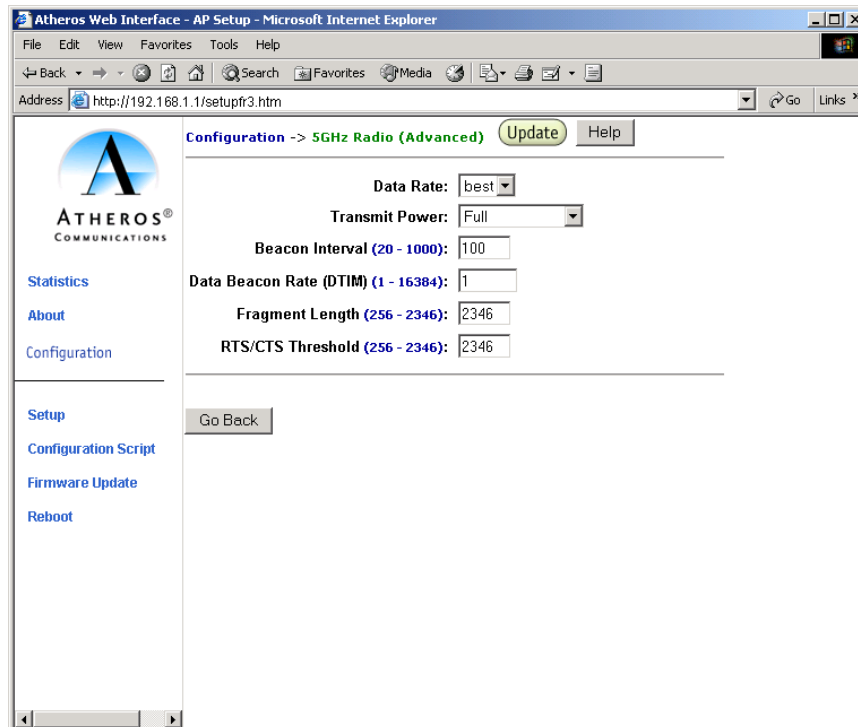

Figure A-11. 5 GHz Radio Advanced Configuration Window

[Table A-8](#) summarizes the data fields on the 5 GHz Radio Advanced Configuration window.

Table A-8. 5 GHz Radio Advanced Configuration Window Field Descriptions

Advanced Configuration Field	Description
Data Rate	Specifies rate of data transmission. Select the desired rate from the drop-down menu. The Best selection will adapt the rate to the best available.
Beacon Interval	Specifies the Beacon Interval value. Enter a value between 20 and 1000.
Data Beacon Rate	Specifies the Data Beacon Rate. Enter a value between 1 and 16384 that specifies the Delivery Traffic Indication Message (DTIM).
Fragment Length	Specifies the fragment length. Enter a value between 256 and 2346.
RTS/CTS Threshold	Specifies the value of the RTS/CTS threshold. Enter a value between 256 and 2346.

DO NOT COPY

2.4 GHz Radio Configuration Window

The 2.4 GHz Radio Configuration window allows the setting of generic 2.4 GHz radio operating information for the AP. The Device's factory firmware will limit the allowable settings depending on country of operation. From the AP Configuration window, Radio Settings to access the 2.4 GHz Radio Configuration window (see Figure A-12).

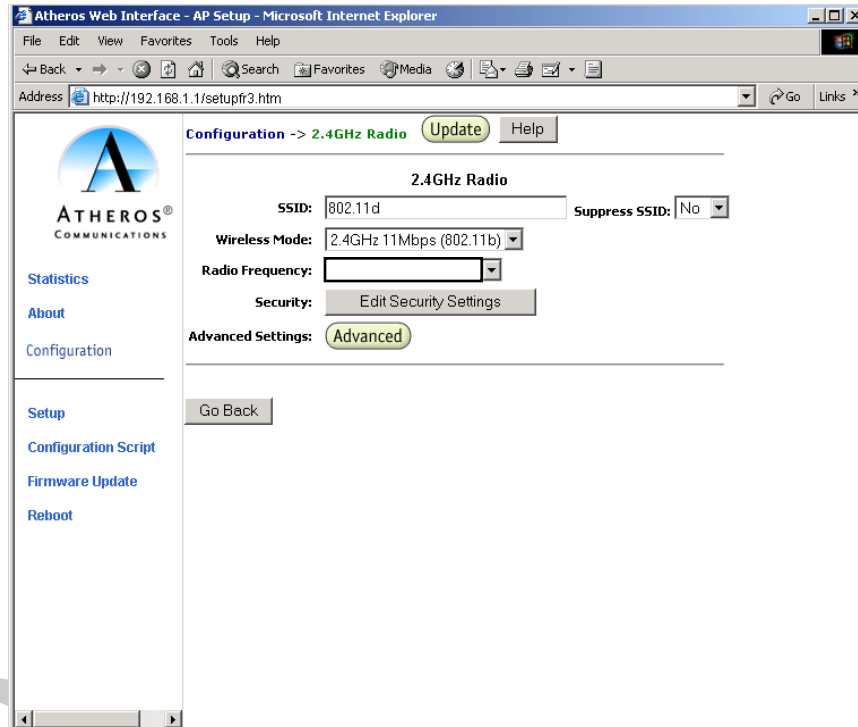

Figure A-12. 2.4 GHz Radio Configuration Window

[Table A-9](#) summarizes the data fields on the 2.4 GHz Radio Configuration window.

Table A-9. 2.4 GHz Radio Configuration Window Field Descriptions

General Configuration Field	Description
SSID	Identification of the AP. Enter a number or address between 1 and 32 characters in length that the STAs are associating with in Infrastructure mode. More than one AP in an SSID can be specified here. Use the System Name field to uniquely identify each AP.
Suppress SSID	Use the checkbox to prevent broadcast of the AP's SSID in beacons. When enabled, the SSID in beacons are not transmitted and only those STAs with prior knowledge of an AP's SSID can associate with that AP.
Wireless Mode	The wireless LAN mode specifies both frequency range and data rates. Firmware loaded on your version of the Access Point at the factory limits the available channel settings.
Security: Edit Security Settings	Click here to edit the security configuration for 2.4 GHz radio operation (refer to " Edit Security Server Settings " on page A-12).
Advanced Settings	Click here to enter advanced configuration for 2.4 GHz radio operation (refer to " 2.4 GHz Radio Advanced Configuration Window " on page A-30).

2.4 GHz Security Configuration Window

The 2.4 GHz Radio Security Configuration window allows the setting of security information for the AP for 5 GHz operation. From the 2.4 GHz Radio Configuration window, click on Edit Security Settings to access the 2.4 GHz Security Configuration window (see [Figure A-13](#)).

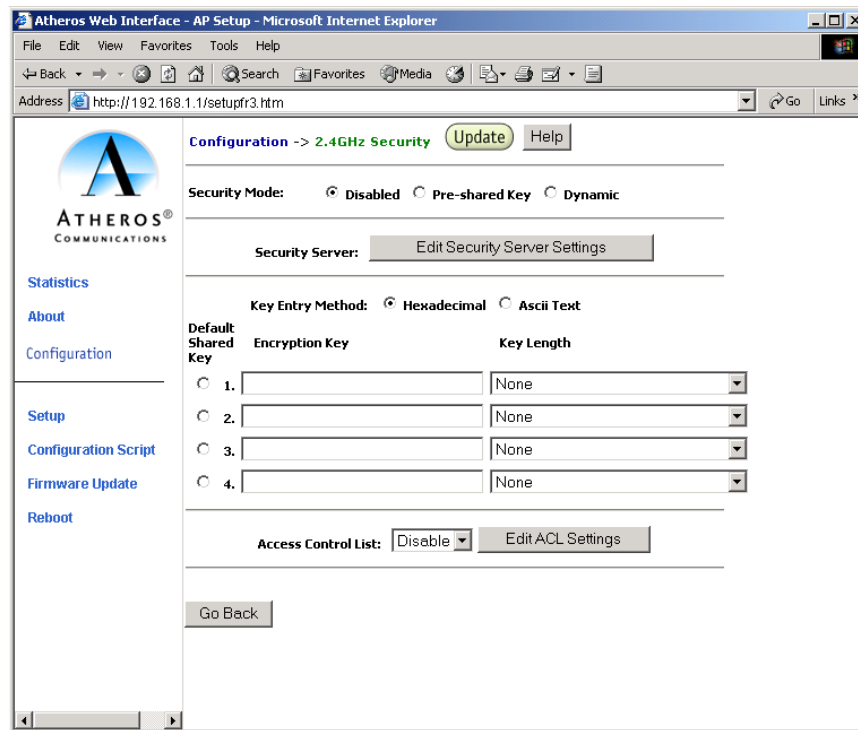

Figure A-13. 2.4 GHz Security Configuration Window

[Table A-10](#) summarizes the data fields on the 2.4 GHz Security Configuration window.

Table A-10. 2.4 GHz Security Field Descriptions

Security Configuration Field	Description
Security Mode	Use the radio buttons to specify the security mode.
Security Server	Click Edit Security Server Settings to change the configuration of the security server.
Key Entry Method	Use the radio buttons to specify the key entry method as either hexadecimal or ASCII.
Default Shared Key	Use the radio button to specify which encryption key to use as the default shared key.
Encryption Key	Specifies the encryption key used for broadcast/multicast frames.
Key Length	Specifies the key length: <ul style="list-style-type: none"> ■ None ■ 10 Hex digits or 5 ASCII text ■ 26 Hex digits or 13 ASCII text ■ 32 Hex digits or 16 ASCII text
Access Control List	Specifies the state of the Access Control List (ACL). Use the drop-down menu to specify the state of ACL, where: <ul style="list-style-type: none"> ■ Disable—Unrestricted Access: By default, while checking of the ACL is enabled, the access control list itself is empty. This is the same as disabling the checking on the ACL. ■ Enable—Restricted Access: An ACL entry must exist before ACL can be enabled. While ACL is enabled, stations with valid shared keys and stations with matching “allow” entries on the ACL are authenticated. ■ Strict—Restricted (w/ACL match): Requires an ACL entry that specifies the station's assigned unique key or the station is denied association. In the strict mode, stations with valid share keys and not on the ACL are not authenticated. The stations must have unique keys defined and matching “allow” ACL entries specified, in order to associate with the AP.
Edit ACL Settings	Click here to edit the configuration of the ACL operation for 2.4 GHz (refer to “2.4 GHz Access Control List Configuration Window” on page A-27).

Edit Security Server Settings

The RADIUS Server Configuration window allows configuration of a RADIUS server for authentication purposes in 802.1X networks. See [Figure A-14](#) for an illustration of the RADIUS Server Configuration window.

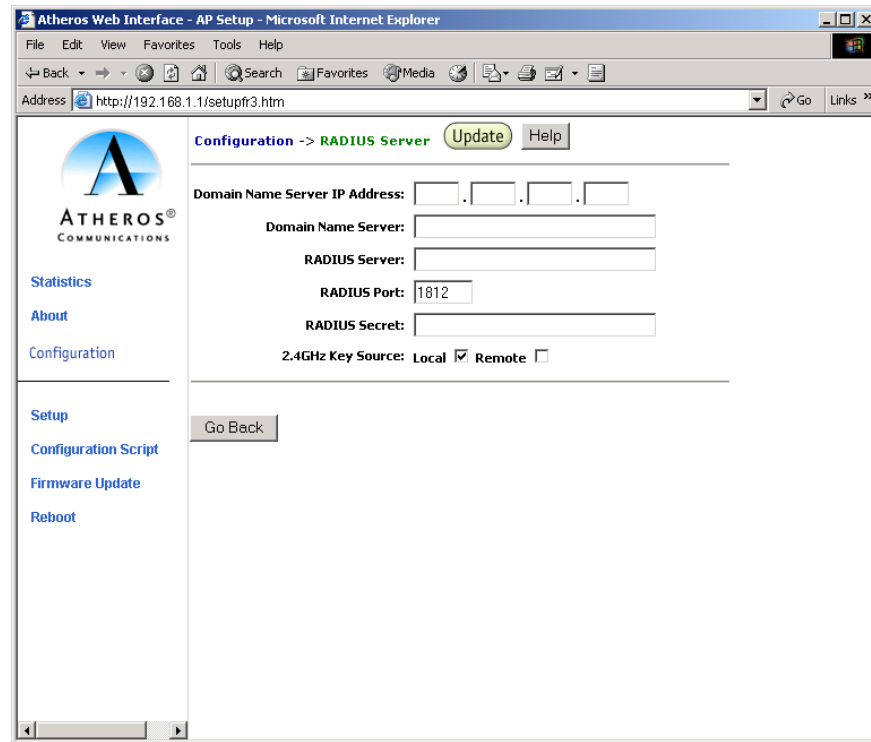

Figure A-14. 2.4 GHz RADIUS Server Configuration Window

[Table A-11](#) summarizes the data fields on the 2.4 GHz RADIUS Server Configuration window.

Table A-11. 2.4 GHz RADIUS Server Configuration Field Descriptions

Security Configuration Field	Description
Domain Name Server IP Address	Specifies the IP address of the domain name server.
Domain Name Server	Specifies the name of the domain name server.
RADIUS Server	Specifies the IP address of the RADIUS server.
RADIUS Port	Specifies the port of the RADIUS server.

Table A-11. 2.4 GHz RADIUS Server Configuration Field Descriptions

Security Configuration Field	Description
RADIUS Secret	Specifies the password for the RADIUS server.
RADIUS Key Source	Specifies the location of the RADIUS keys. Use the “local” checkbox to specify the RADIUS keys are located in the AP. Use the “remote” checkbox to specify the RADIUS keys are located in the RADIUS server.

2.4 GHz 802.1X Configuration

The IEEE 802.1X protocol is designed to support port-based authentication and secure key distribution. It can be used to distribute unique encryption keys for an entire BSS. Atheros provides support for this protocol on both the AP and the STA.

To enable 802.1X on the AP, take the following steps on the 2.4 GHz RADIUS Server Configuration window:

1. Specify the domain name server IP address.
2. Specify the name of the domain server.
3. Specify a RADIUS Server name.
4. Specify a RADIUS Server secret.
5. Specify the location of the 2.4 GHz Key Source as *Remote*.

2.4 GHz Access Control List Configuration Window

The 2.4 GHz Radio Configuration window allows the setting of security information for the AP. From the 2.4 GHz Security Configuration window, click on Edit ACL Settings to access the 2.4 GHz ACL Configuration window (see [Figure A-15](#)).

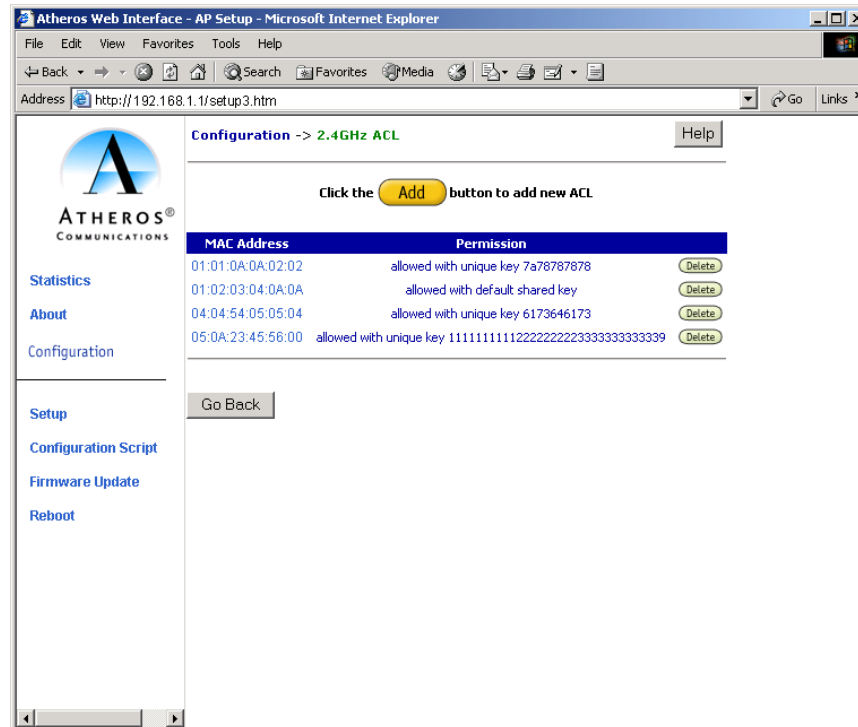

Figure A-15. 2.4 GHz Access Control List Configuration Window

Click Delete to remove any list item.

Adding New Access Control Lists

The 2.4 GHz Security New ACL Configuration window allows you to add new access control list item. From the 2.4 GHz ACL Configuration window, click Add to list to enter new list items (see [Figure A-16](#)).

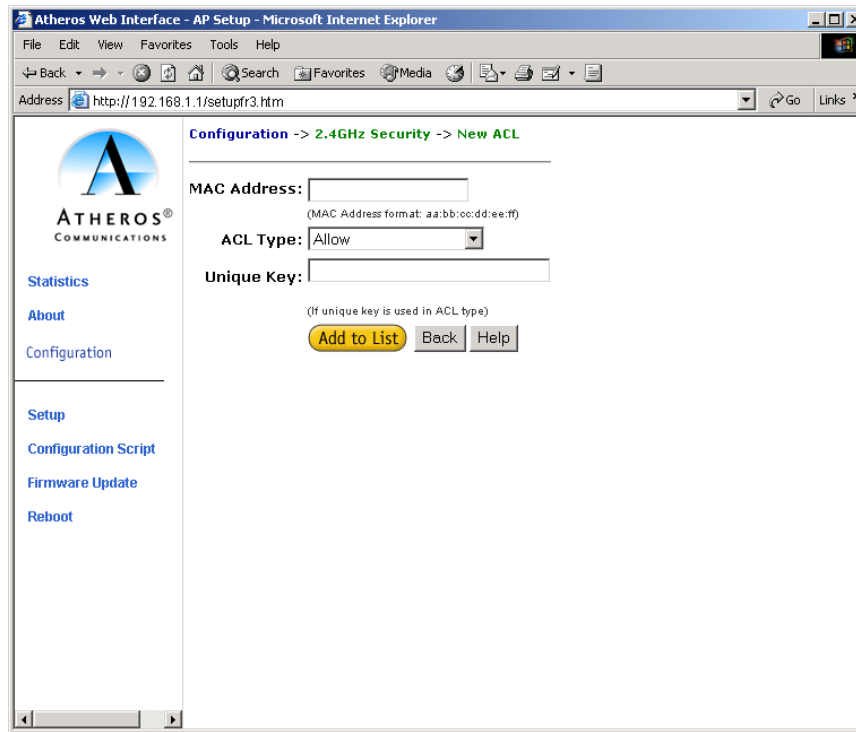

Figure A-16. 2.4 GHz New Access Control List Configuration Window

[Table A-12](#) summarizes the data fields on the 2.4 GHz New Access Control List window

Table A-12. 2.4 GHz New Access Control List Field Descriptions

Per Station Privacy Field	Description
MAC Address	Specifies the MAC address for the STA to be included in the ACL.
ACL Type	Specifies the current state of each STA, where: <ul style="list-style-type: none"> ■ Allowed—Enable access for this MAC address to the ACL. ■ Denied—Deny access for this MAC address to the ACL. ■ Default Shared Key—This MAC address would use the default shared key. ■ 64/128/152 Bits—Specifies lengths for shared keys.
Unique Key	Enter a unique key.

Adding Access Control List Permissions

The 2.4 GHz ACL Configuration window allows you to add permission for each list item. From the 2.4 GHz ACL Configuration window, click on a MAC address in the list to view the 2.4 GHz Security Edit ACL Configuration window (see [Figure A-17](#)).

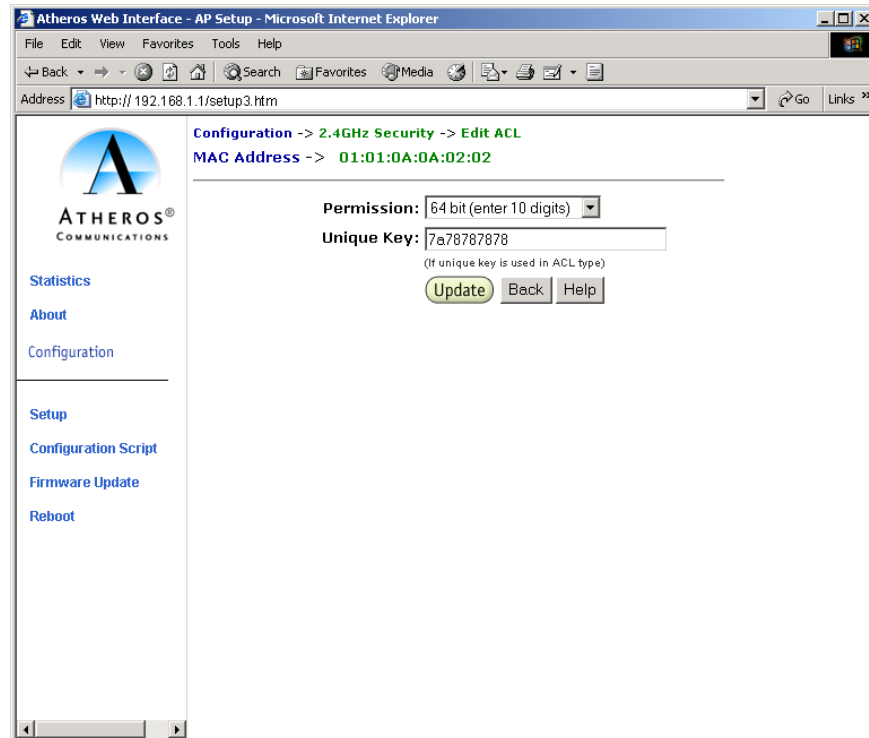

Figure A-17. 2.4 GHz Security Edit ACL Configuration Window

[Table A-13](#) summarizes the data fields on the 2.4 GHz Security Edit ACL Configuration window.

Table A-13. 2.4 GHz Security Edit Access Control List Field Descriptions

Per Station Privacy Field	Description
Permission	Specifies the current state of each STA, where: <ul style="list-style-type: none"> ■ Allowed—Enable access for this MAC address to the ACL. ■ Denied—Deny access for this MAC address to the ACL. ■ Default Shared Key—This MAC address would use the default shared key. ■ 64/128/152 Bits—Specifies lengths for shared keys
Unique Key	Enter a unique key.

2.4 GHz Radio Advanced Configuration Window

The 2.4 GHz Radio Advanced Configuration window allows the setting of 2.4 GHz advanced, radio operating information for the AP. Device's firmware loaded at the factory will limit available settings. From the 2.4 GHz Radio Configuration window, click on Advanced to access the 2.4 GHz Radio Advanced Configuration window (see [Figure A-18](#)).

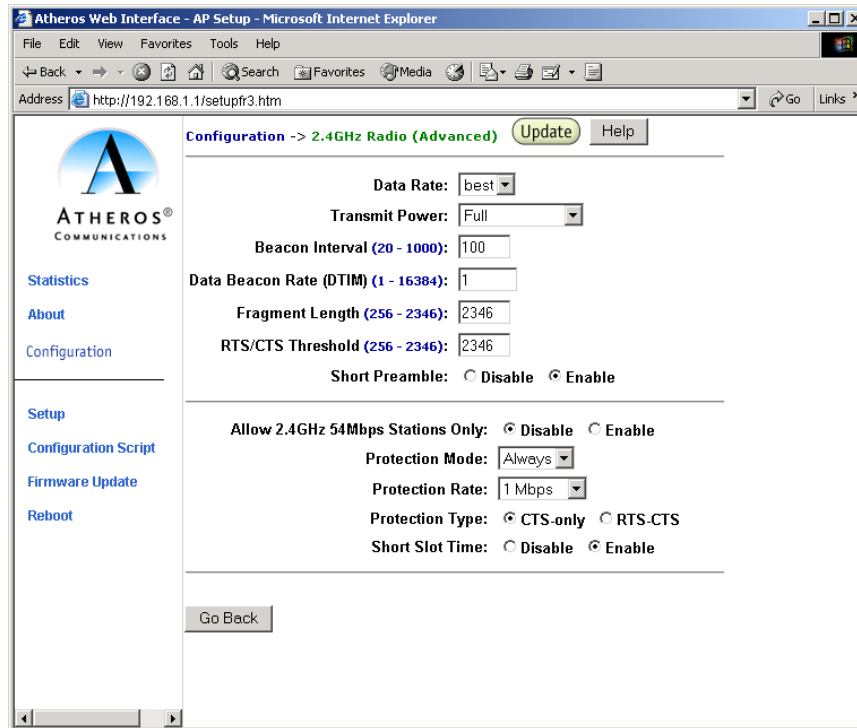

Figure A-18. 2.4 GHz Radio Advanced Configuration Window

Table A-14 summarizes the data fields on the 2.4 GHz Radio Advanced Configuration window.

Table A-14. 2.4 GHz Radio Advanced Configuration Window Field Descriptions

Advanced Configuration Field	Description
Data Rate	Specifies rate of data transmission. Select the desired rate from the drop-down menu. The Best selection will adapt the rate to the best available.
Beacon Interval	Specifies the Beacon Interval value. Enter a value between 20 and 1000.
Data Beacon Rate	Specifies the Data Beacon Rate. Enter a value between 1 and 16384 that specifies the Delivery Traffic Indication Message (DTIM).
Fragment Length	Specifies the fragment length. Enter a value between 256 and 2346.
RTS/CTS Threshold	Specifies the value of the RTS/CTS threshold. Enter a value between 256 and 2346.
Short Preamble	Use the radio button to specify short preamble (11b) usage. When enabled, both short and long preambles are used. When disabled, only long preambles are used.
Allow 2.4 GHz 54 Mbps Stations Only	Use the radio button to enable or disable the association of 2.4 GHz 54 Mbps station only.
Protection Mode	Specifies the operation of CTS protection mode: <ul style="list-style-type: none"> <input type="checkbox"/> None <input type="checkbox"/> Always <input type="checkbox"/> Auto
Protection Rate	Specifies the operation of CTS protection rate: <ul style="list-style-type: none"> <input type="checkbox"/> 1 Mbps <input type="checkbox"/> 2 Mbps <input type="checkbox"/> 5.5 Mbps <input type="checkbox"/> 11 Mbps
Protection Type	Specifies the operation of CTS protection type: <ul style="list-style-type: none"> <input type="checkbox"/> CTS only <input type="checkbox"/> RTS-CTS
Short Slot Time	Use the radio button to specify short time shot usage.

Script Configuration Window

The Script Configuration window allows execution of text scripts of CLI commands. For example, construction of a text script to enter the shared keys for stations. All set commands can be used in scripts, except **set security**, **set password**, **find bss**, **ftp password**, and **ping**.

Figure A-19 illustrates an example of an AP Script Configuration Window.

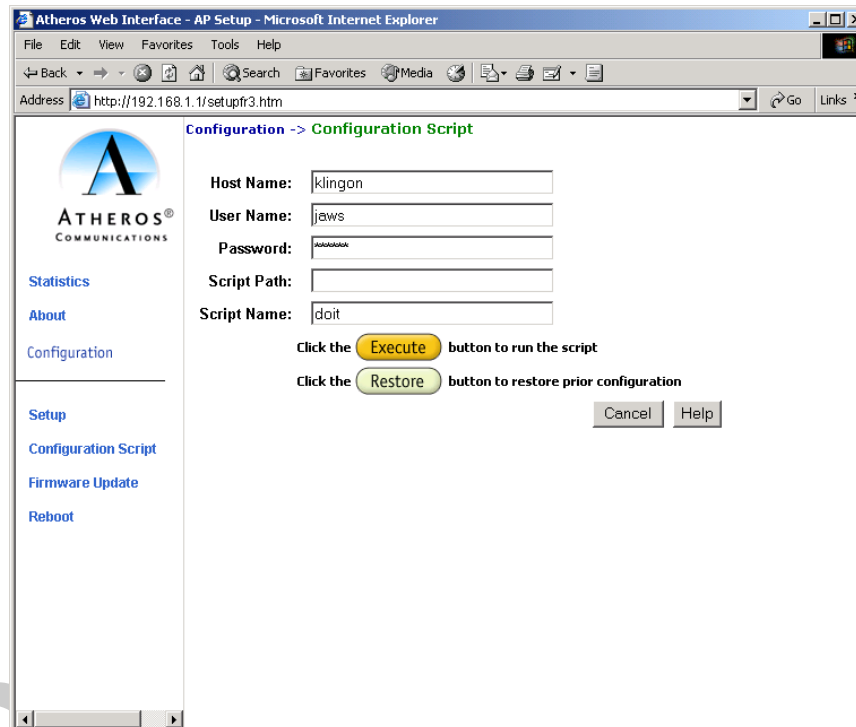

Figure A-19. Configuration Script Configuration Window

Follow these steps to use scripts:

1. Develop the scripts for the application.
2. Enter the host name where the script resides.
3. Enter the user name and password for the host.
4. Specify the script path and the script name in the data entry fields in the Configuration Script window.
5. Click Execute to run the script.

To revert to the previous configuration, click Restore.

Firmware Update Configuration Window

The Firmware Update Basic Configuration window allows viewing of the FTP location of new firmware. The default values for the Host Name, Image Path, and Image Name appear in the window.

To access the Firmware Update window, click on Firmware Update in the navigation bar. The Firmware Update Configuration Window appears (see [Figure A-20](#)).

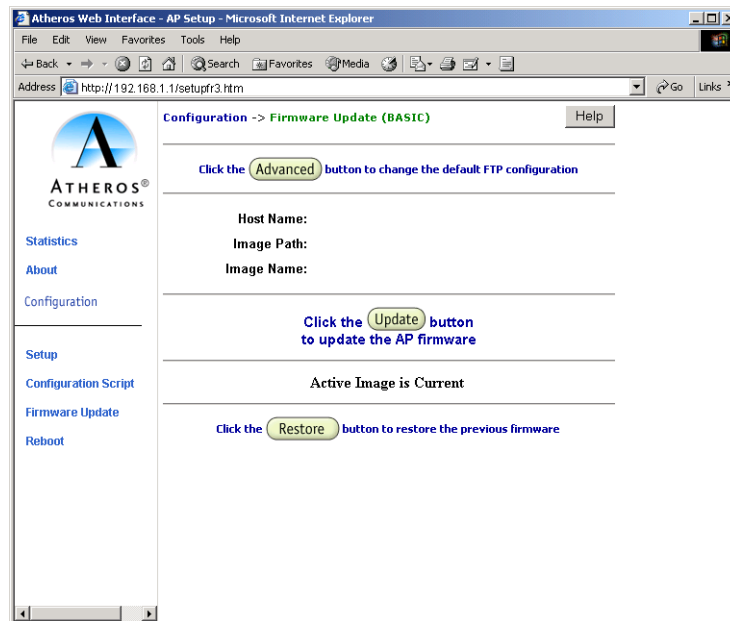

Figure A-20. AP Firmware Update Configuration Window

The AP uses the File Transfer Protocol (FTP) to download the Operating image from the HPC. An FTP server utility is required to perform the data transfer between the AP and HPC.

Follow these steps to enable firmware updates:

1. From the Firmware Update Basic window, click on Advanced.

The AP Firmware Update Advanced Configuration window appears (see [Figure A-21](#)).

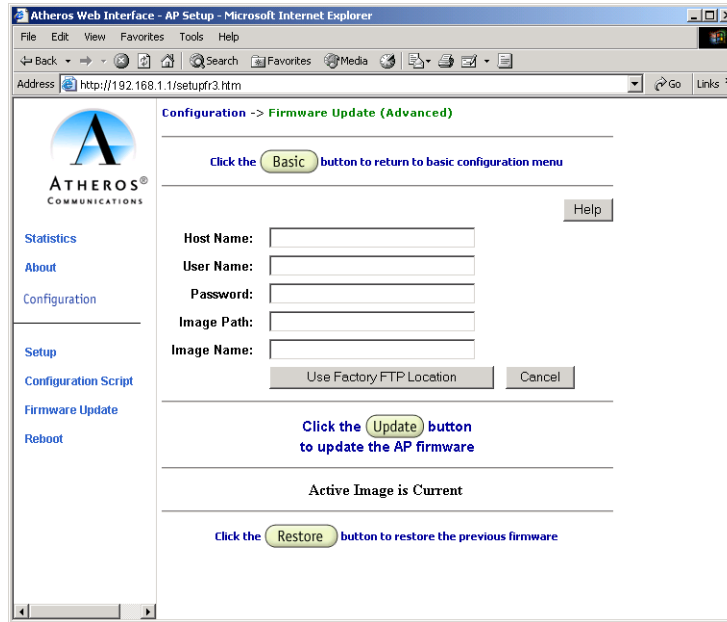

Figure A-21. Advanced Firmware Update Configuration Window

The Firmware Update Advanced Configuration window allows the setting of new information on the FTP location of new firmware or filename of the firmware.

2. Enter the Host Name or host PC's IP address, User Name, Password, Image Path, and Image Name in the data-entry fields.

To revert to the default-vendor values, click Use Factory FTP Location.

3. Click Update Firmware to store the new firmware changes.

To restore the previous firmware, click Restore.

Statistics Windows

From the AP Web Server, choose the Statistics hyperlink to go to the Access Point Statistics window. By default, this is the first window that appears once the AP Web Server opens.

The AP Statistics window allows viewing of the assigned ID, MAC address, and current state of the AP and all stations currently part of its BBS (Basic Service Set). The top-level Statistics window automatically updates each minute.

AP Statistics

To view statistics on the AP, click on the MAC address hyperlink for the desired AP in the Statistics window. The BSS Stats window for the selected AP will appear. See [Figure A-22](#) for an example of a BSS Stats window for an AP.

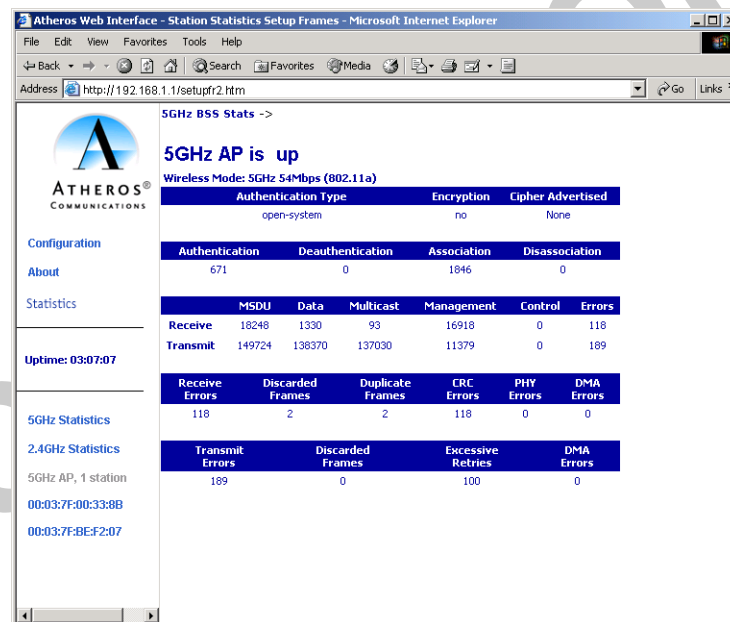

Figure A-22. Basic Service Set Statistics Window for an AP

The BSS Stats window for AP is divided into sections that provide the AP configuration, Access Point SME statistics (station association information), or Access Point (Transmit and Receive) Statistics. Refer to [Table A-15](#) for a description of the BSS Statistics for AP window fields.

Table A-15. BSS Stats Field for AP Descriptions

BSS Stats Field	Description
State	Current state of the AP.
Authentication Type	Specifies open-system or shared key.
Encryption	Specifies the enabled state of encryption; either yes or no.
Cipher Advertised	Specifies current state of advertised cipher negotiations, AES and/or WEP, and None (clear).
Authentication/Deauthentication	Number of times a STA attempted authentication and deauthentication.
Association/Deassociation	Number of times a STA attempted associations and deassociations.
MSDU	Maximum Service Data Unit. Specifies the number of packets sent and received by the AP.
Data/Management/Control	Packets can either be data, control, or management. Specifies the number of packets sent and received for each.
Multicast	Specifies the number of multicast packets both sent and received.
Errors	Specifies the error count for both transmit and receive.
Receive Errors	Specifies the number of receive errors.
Discarded Frames	Specifies the number of receive discarded frames.
Duplicate Frames	Specifies the number of receive duplicate frames.
CRC Errors	Specifies the number of receive CRC errors.
PHY Errors	Specifies the number of receive PHY errors.
DMA Errors	Specifies the number of receive DMA errors.
Transmit Errors	Specifies the number of transmit errors.
Discarded Frames	Specifies the number of transmit discarded frames.
Excessive Retries	Specifies the number of transmit excessive retries.
DMA Errors	Specifies the number of transmit DMA errors.

The AP Stats window automatically updates every five seconds.

Station Statistics

To view statistics on any STA, click on the MAC address hyperlink for the desired STA. The BSS Stats window for the selected STA will appear. See [Figure A-23](#) for an example BSS Stats window for a station.



Figure A-23. Basic Service Set Statistics Window for Station

The BSS Stats window for stations provides the station configuration and statistics for the selected station.

Table A-16 summarizes the information fields on the BSS Stats window for a STA.

Table A-16. BSS Stats Fields for STA Descriptions

BSS Stats Window for STA Field	Description
AID	The ID of the STA.
State	The current state of the STA
Power Save	Specifies the enabled state of the power save option; either yes or no.
Encryption	Specifies current state of encryption; AES and/or WEP, and None (clear).
Advertised Cipher	Specifies the supported cipher types.
Unicast Cipher	Specifies the current unicast cipher type used.
Multicast Cipher	Specifies the current multicast cipher type used.
Authentication/Deauthentication	Number of times a STA attempted authentication and deauthentication.
Association/Deassociation	Number of times a STA attempted associations and deassociations.
MSDU	Maximum Service Data Unit. Specifies the number of packets sent and received by the STA.
Data/Management/Control	Packets can either be data, control, or management. Specifies the number of packets sent and received for each.
Multicast	Specifies the number of multicast frames.
Errors	Specifies the error count for both transmit and receive sides.
Signal Strength	Specifies the strength of the transmit and receive signals in dBm.
Data Rate (Mbps)	Specifies the transmit and receive data rate in Mbps.
Receive Errors	Specifies the number of receive errors.
Discarded Frames	Specifies the number of receive discarded frames.
Duplicate Frames	Specifies the number of receive duplicate frames.
CRC Errors	Specifies the number of receive CRC errors.
PHY Errors	Specifies the number of receive PHY errors.
DMA Errors	Specifies the number of receive DMA errors.
Transmit Errors	Specifies the number of transmit errors.
Discarded Frames	Specifies the number of transmit discarded frames.
Excessive Retries	Specifies the number of transmit excessive retries.
DMA Errors	Specifies the number of transmit DMA errors.

B

Regulatory Compliance Information

This section includes user requirements for operating this product in accordance with National laws for usage of radio spectrum and operation of radio devices. Failure of the end-user to comply with the applicable requirements may result in unlawful operation and adverse action against the end-user by the applicable National regulatory authority.

NOTE: The Atheros Access Point firmware limits operation to only the allowable channels of operation applicable for the particular in which the Access Point is marketed.

FCC Requirements for Operation in the United States

Radio Frequency Interference Warnings & Instructions

This device is restricted to **indoor use** due to its operation in the 5.15 to 5.25 GHz frequency range. The FCC requires this product to be used only indoors to reduce the potential for harmful interference to co-channel Mobile Satellite systems.

High power radars may use the 5.25 to 5.35 GHz or 5.47 to 5.725 GHz frequency ranges in your area. Such radar stations can cause interference or damage to this device. This device implements a radar detection function which may cause interruption of normal operation when a radar signal is detected.

This equipment has been tested and found to comply with the limits for a Class B digital device, pursuant to Part 15 of the FCC Rules. These limits are designed to provide reasonable protection against harmful interference in a residential installation. This equipment uses and can radiate radio frequency energy and, if not installed and used in accordance with the instructions, may cause harmful interference to radio communications.

However, there is no guarantee that interference will not occur in a particular installation. If this equipment does cause harmful interference to radio or television reception, which can be determined by turning the equipment off and on, the user is encouraged to try to correct the interference by one or more of the following methods:

- Reorient or relocate the receiving antenna
- Increase the separation between the equipment and the receiver
- Connect the equipment into an electrical outlet on a circuit different from that which the radio receiver is connected
- Consult the dealer or an experienced radio/TV technician for help.

Modifications made to the product, unless expressly approved by Atheros Communication, could void the user's right to operate the equipment.

RF Exposure

CAUTION: To ensure compliance with FCC RF exposure requirements, the antenna used for this device must be installed to provide a separation distance of at least 20 cm from all persons. This device must not be located or operated in conjunction with any other antenna or radio transmitter.

Declaration Of Conformity

We Atheros Communications, Inc.,

5480 Great America Parkway, Santa Clara, CA 95054

declare under our sole responsibility this product complies with Part 15 of FCC Rules. Operation is subject to the following two conditions:

- This device may not cause harmful interference, and
- This device must accept any interference received, including interference that may cause undesired operation.