

Data Sheet

(Emc Use)

Product Type	WLAN Antenna
Notebook Model Number	PEGATRON / F80-series(F80L/S/Cr)
Part No. / YAGEO / Main + Aux	CAN4313 717 012501B

Yageo (Taiwan) Ltd.

16, west 3rd Street, N.E.P.Z Kaohsiung, 811 Taiwan, R.O.C

Yageo Electronics (China) Co, Ltd

No. 10, Zhu Yuan Road, Suzhou New District, Suzhou, PRC

2.45/5GHz Multi Band and WWAN Antenna with Cable & Connector for IEEE802.11b, 11g, 11a, 11n UNII	Yageo Corporation SPD		R01	Mar. 27, 08
	Datasheet Current Revision:			
	R01			
BY /	Candy Lin	DATE /	Mar. 27, 2008	

Table of Contents

- 1. Specifications**
 - 1.1 Specifications**
 - 1.2 Antenna Dimension / Cable Length**
 - 1.3 Packing Spec.**
 - 1.4 Antenna Pictures**

- 2. Test Methodology**
 - 2.1 Test Equipment**
 - 2.2 Test Setup**
 - 2.2.1 Frequency Range**
 - 2.2.2 Antenna Configuration**
 - 2.2.3 VSWR**
 - 2.2.4 Radiation Pattern and Gain**

- 3. Performance Data**
 - 3.1 VSWR in the Fixture (Main/Aux Antenna)**
 - 3.2 Radiation Pattern and Gain**
 - 3.2.1 Low Frequency (2.40GHz~2.50GHz) (Main)**
 - 3.2.2 Middle Frequency (5.15GHz~5.35GHz)**
 - 3.2.3 High Frequency (5.47GHz~5.85GHz)**
 - 3.2.4 Low Frequency (2.40GHz~2.50GHz) (Aux)**
 - 3.2.5 Middle Frequency (5.15GHz~5.35GHz)**
 - 3.2.6 High Frequency (5.47GHz~5.85GHz)**
 - 3.3 Average Gain Summary (Main/Aux Antenna)**

- 4. Antenna Drawing**

- 5. Reliability Data for Antenna Patch**

- 6. Ordering Information: Yageo Ordering P/N Code**

- 7. Revision Control**

- 8. UL Card**

1. Specifications

1.1 Specifications for Antennas

Frequency Range (GHz)	2.40 ~ 2.50 for 802.11b/g/n 5.15 ~ 5.85 for 802.11a
VSWR	2.50 for 2.4GHz band For WL 2.50 for 5.0GHz band For WL
Peak Gain (dBi)	1.74dBi for 2.4GHz band 1.47dBi for 5.0GHz band
MiniPCI Connector	Ipex
Impedance	50Ω
Operating Temperature	-40~90°C
Maximum Power	1W
Polarization	Linear
Radiation Pattern	Omni-Directional

1.2 Antenna Dimension / Cable Length

Product	PEGATRON / F80-series(F80L/S/Cr)
Main antenna (LCD)	40.0*0.8*0.4 mm / 526.0 mm, Color Black
Aux antenna (LCD)	40.0*0.8*0.4 mm / 674.0 mm, Color White

1.3 Packing Spec.

Product	For Example
Inner tray	60
Carton box	265*100

Note: Real packing will base on current project type and samples quantity to definition.



1.4 Antenna Pictures



Main /Aux Antenna

2. Test Methodology

2.1 Test Equipment

The equipment for the antenna measurement we used is as follows.

- A. Agilent 8753ET / 8719D Network Analyzer to measure the VSWR and input impedance.
- B. Three-dimensional anechoic chamber to measure the gain
(Standard dipole and horn were used to calibrate the chamber)
- C. Digital caliper to measure the dimensions.
- D. Climatic chamber for mechanical tests.

2.2 Test Setup

2.2.1 Frequency Range

- 2.40 ~ 2.50GHz, 5.15 ~ 5.85GHz for WLAN
- 900 / 1800 / 1900 / 2100MHz for WWAN

2.2.2 Antenna configuration

The antenna basically has two parts; the stamping and the cable assembly with the connector on one side. The detailed drawing is attached.

2.2.3 VSWR

The VSWR is measured with Agilent 8753ET / 8719D network analyzer. All the measurements are performed with the customer provided fixture. Figure 1 shows the schematic diagram for measuring VSWR.

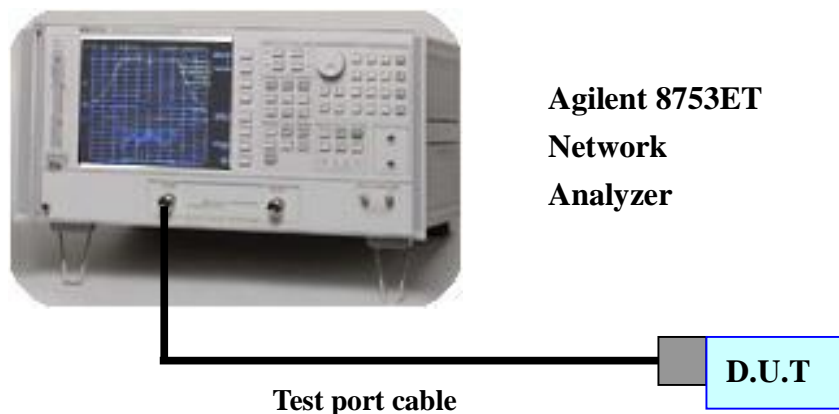

Figure 1. The schematic diagram for measuring VSWR

2.2.4 Radiation Pattern and Gain

The radiation pattern must have the omni-directional characteristic in both positions. The radiation pattern measurements are performed in the three-dimensional anechoic chamber. The chamber provides less than -30dB reflectivity from 800MHz through 8GHz. The chamber is calibrated using both standard dipole and horn antenna. The gain here is expressed as dBi that standardizes the isotropic antenna. The gain measurements are also performed in the same chamber described previously. Figure 2 shows the schematic diagram for measuring radiation pattern and gain.

2D Anechoic chamber

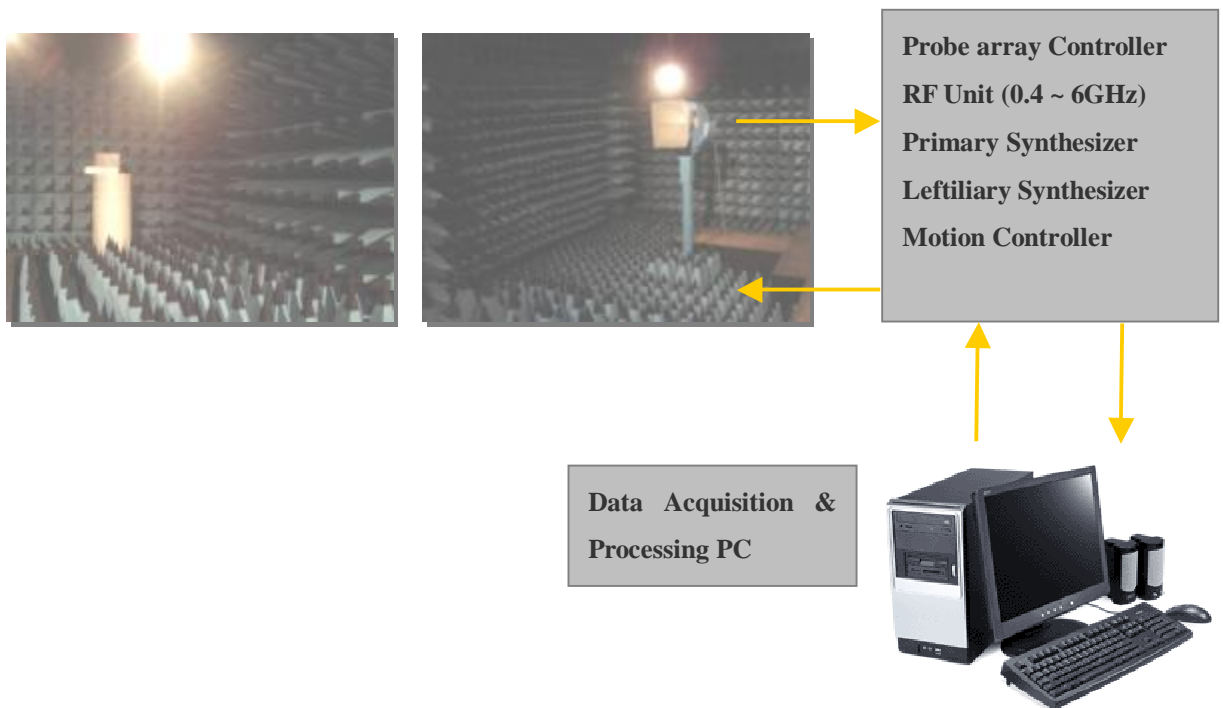

Figure 2. The schematic diagram for measuring radiation pattern and gain

3. Performance Data

3.1 VSWR in the Fixture (Main antenna)



3.1.1 VSWR in the Fixture (Aux antenna)

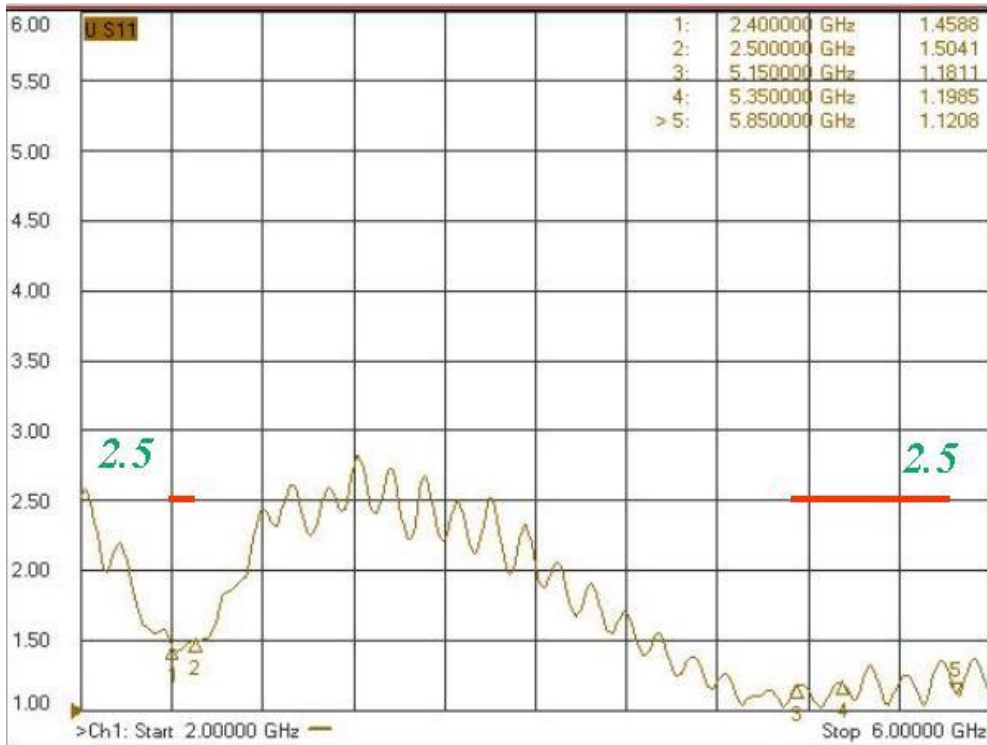

3.2 Radiation Pattern and Gain

3.2.1 Low Frequency (2.40GHz~2.50GHz) / Main Antenna

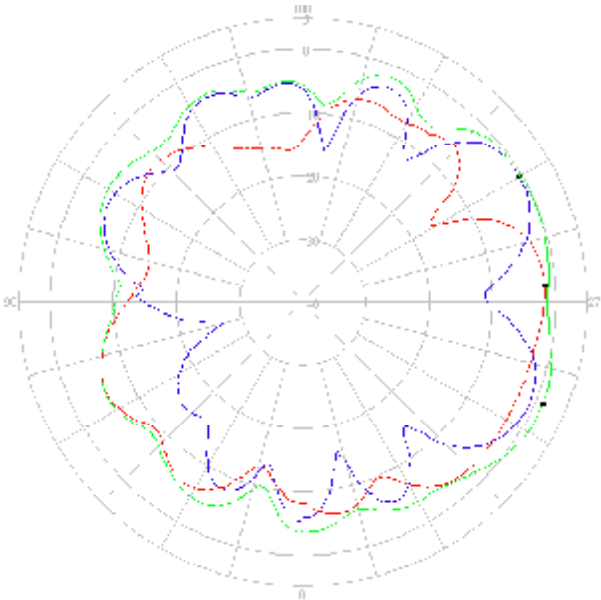

2.4GHz

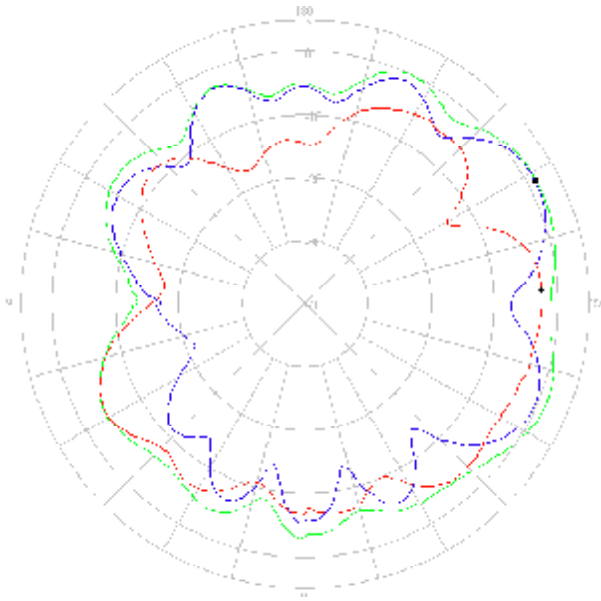

2.45GHz

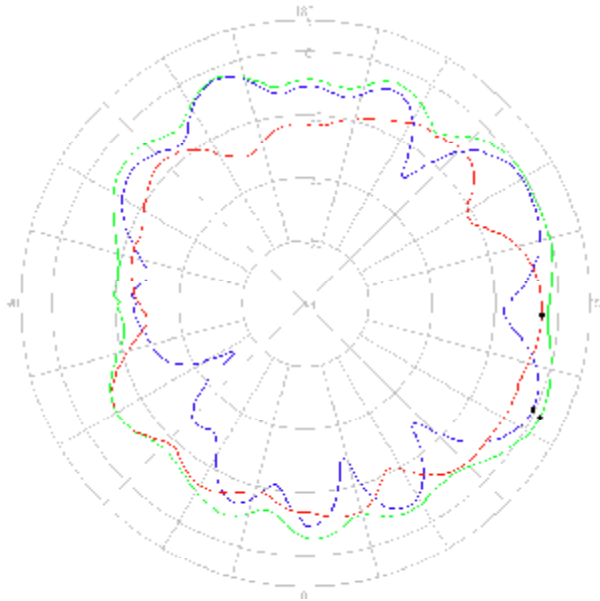

2.5GHz

- **Horizontal**
- **Vertical**
- **H+V**

3.2.2 Middle Frequency (5.15GHz~5.35GHz) / Main Antenna

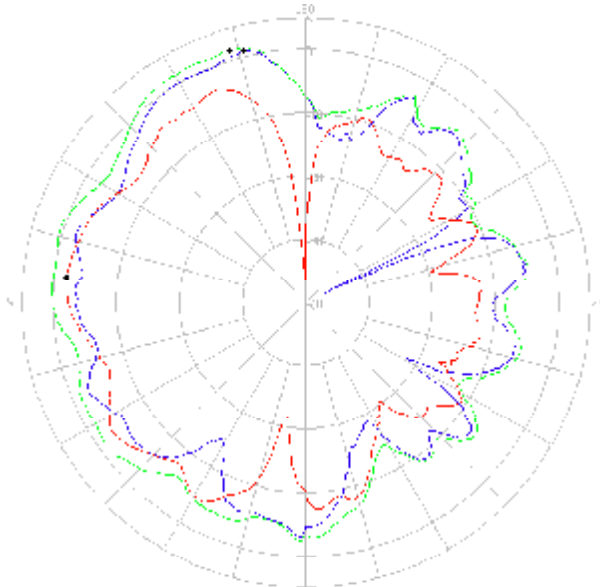

5.15GHz

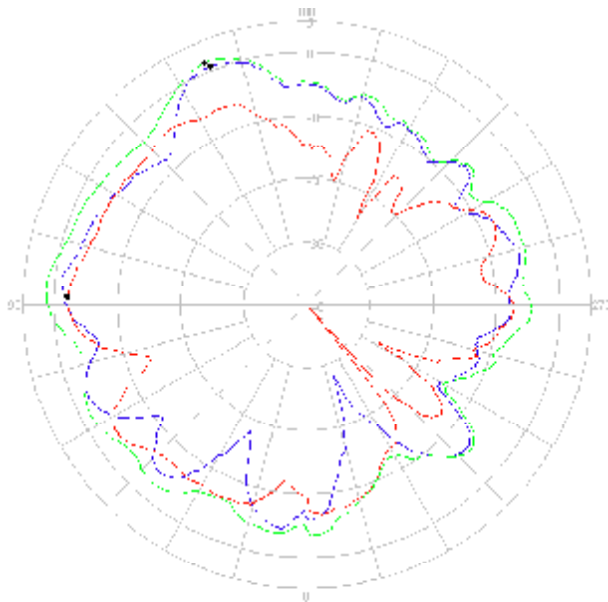

5.25GHz

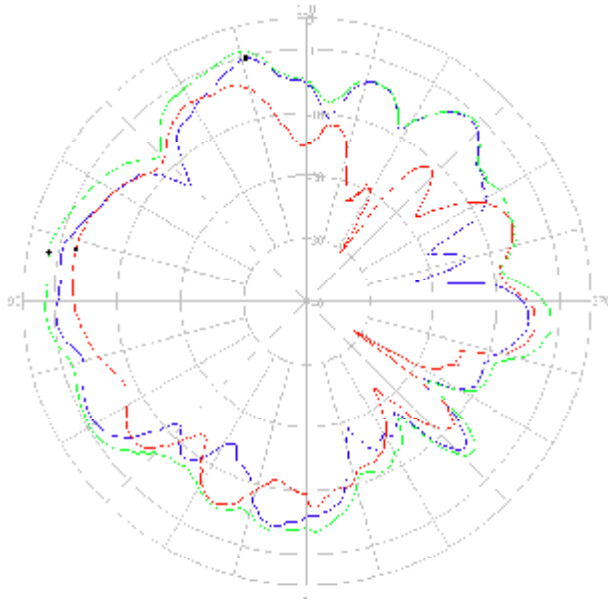

5.35GHz

- Horizontal**
- Vertical**
- H+V**

3.2.3 High Frequency (5.47GHz~5.85GHz) / Main Antenna

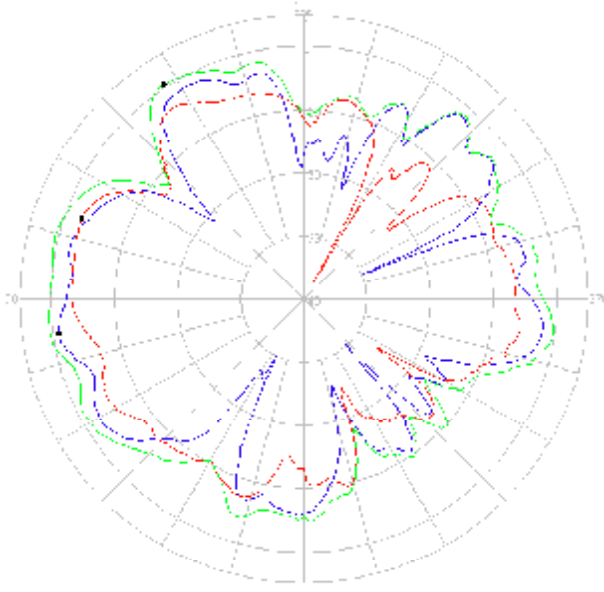

5.47GHz

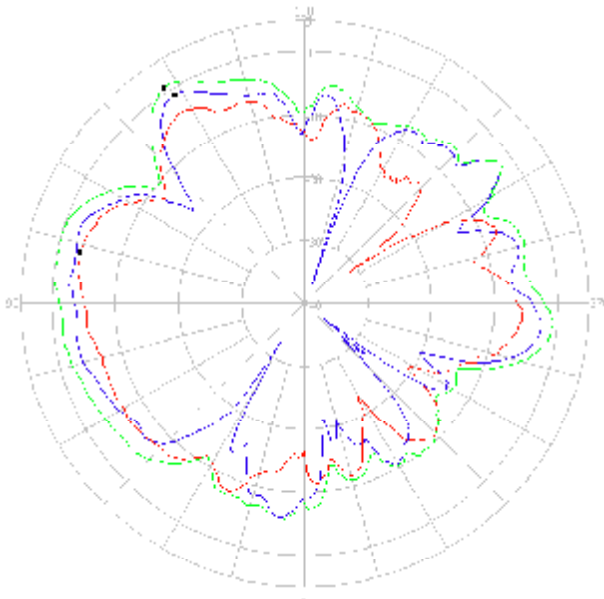

5.6GHz

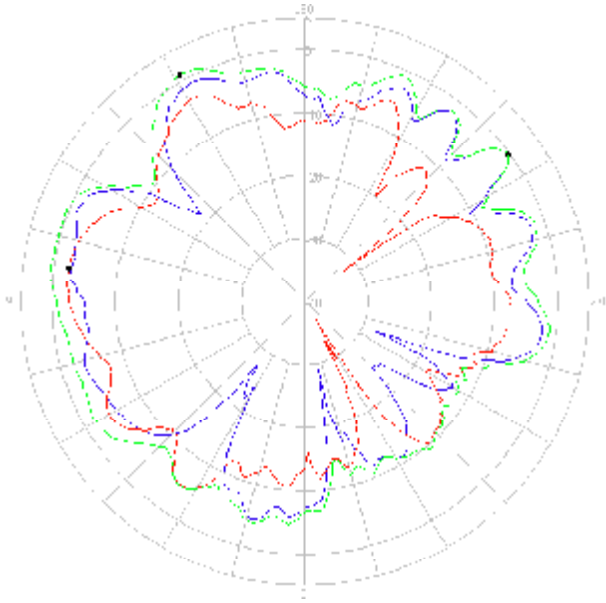

5.725GHz

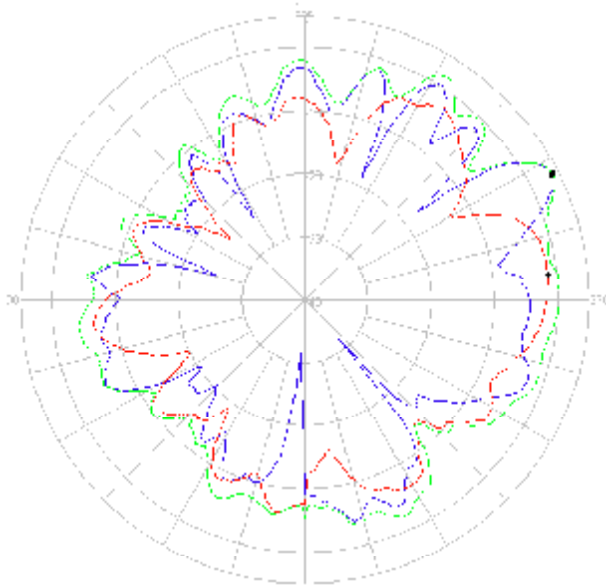

5.785GHz

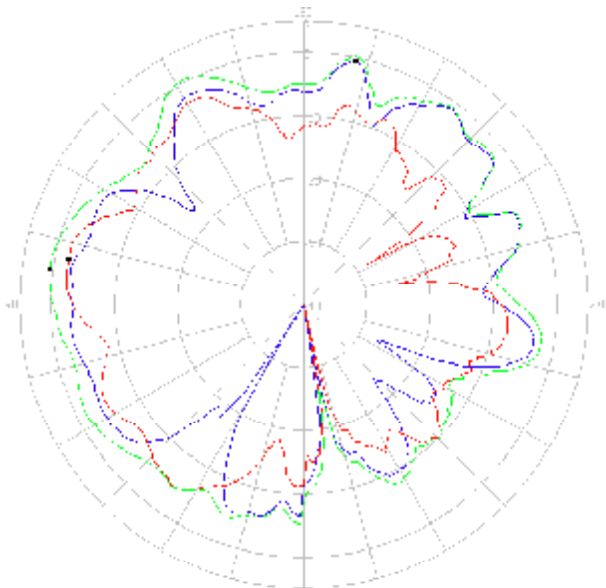

5.85GHz

- **Horizontal**
- - - **Vertical**
- **H+V**

3.2.4 Low Frequency (2.40GHz~2.50GHz) / Aux Antenna

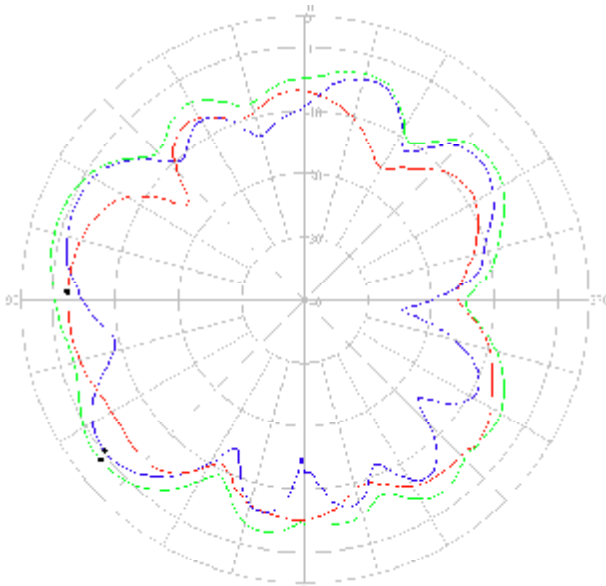

2.4GHz

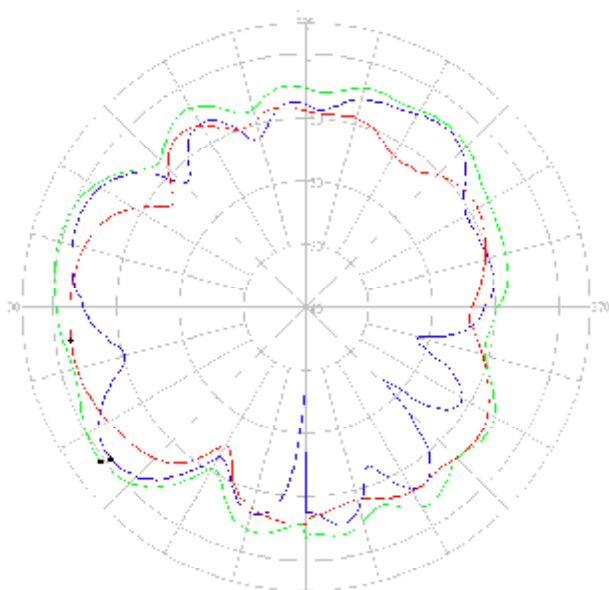

2.45GHz

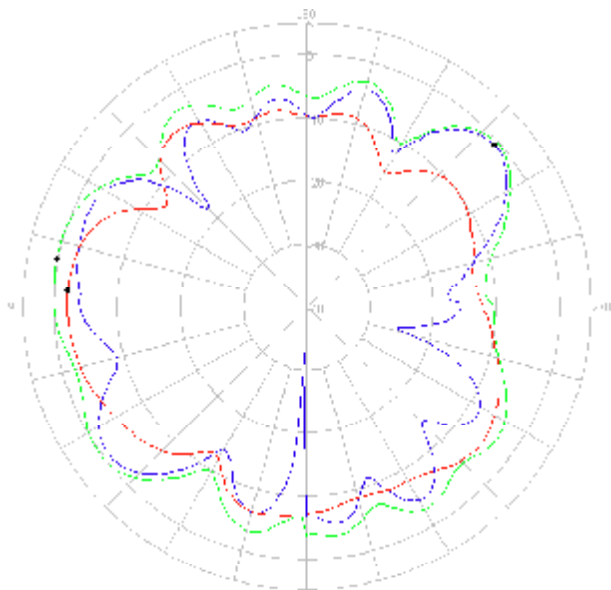

2.5GHz

- **Horizontal**
- **Vertical**
- **H+V**

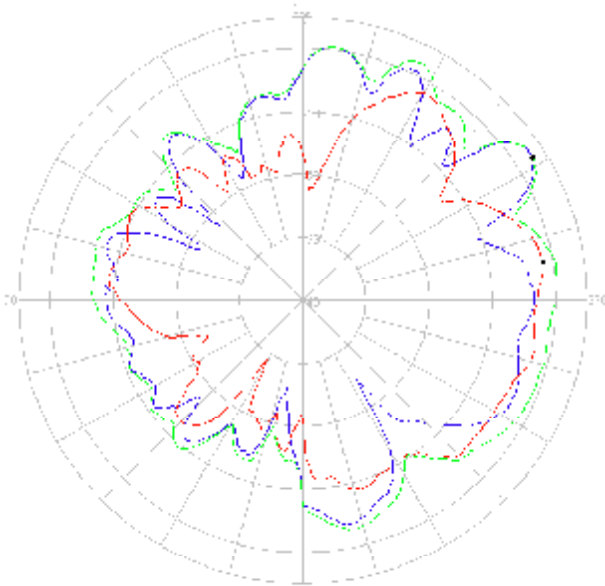

3.2.5 Middle Frequency (5.15GHz~5.35GHz) / Aux Antenna

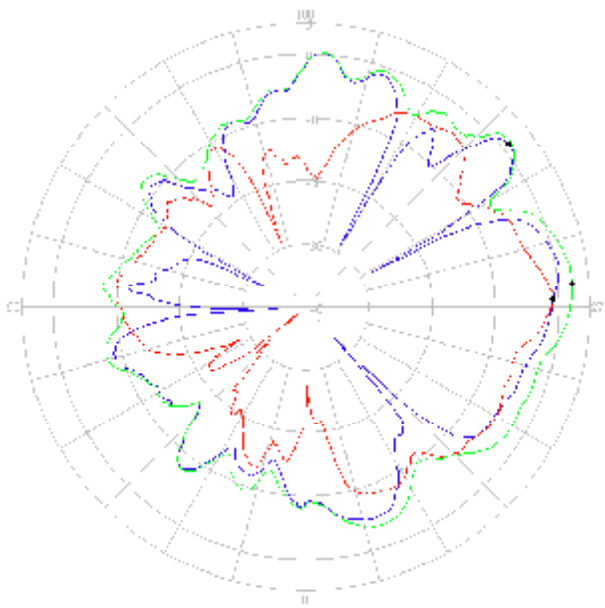

5.15GHz



5.25GHz

-  **Horizontal**
-  **Vertical**
-  **H+V**

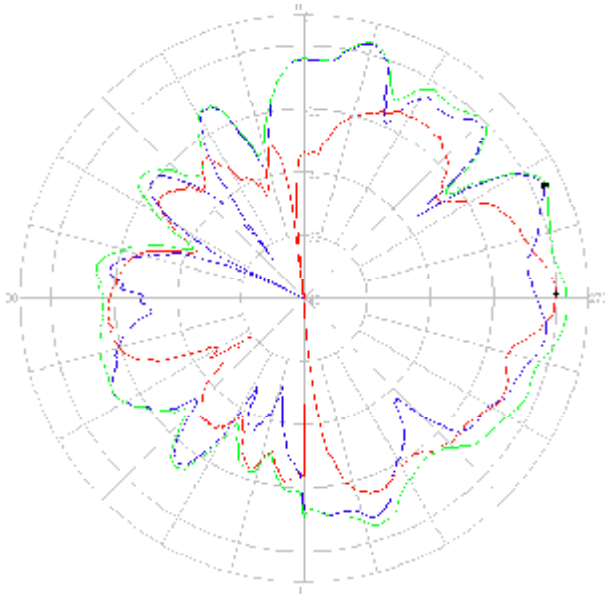

5.35GHz

3.2.6 High Frequency (5.47GHz~5.85GHz) / Aux Antenna

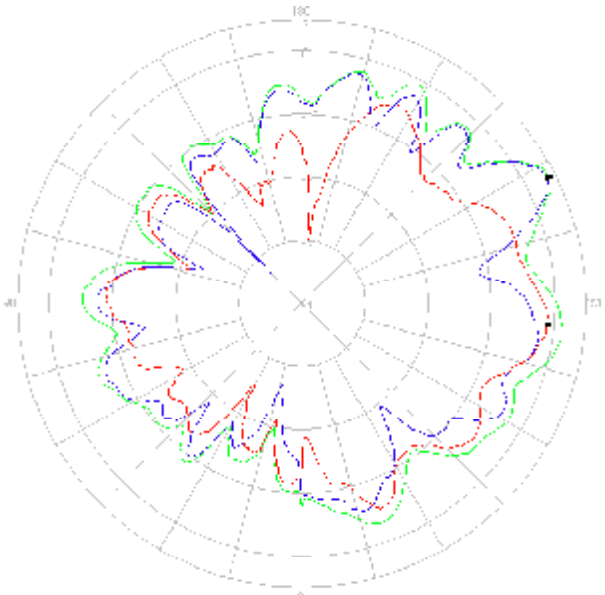

5.47GHz

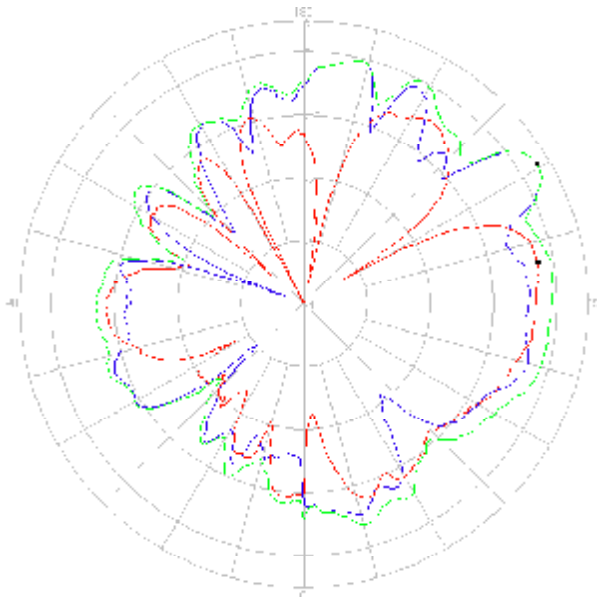

5.6GHz

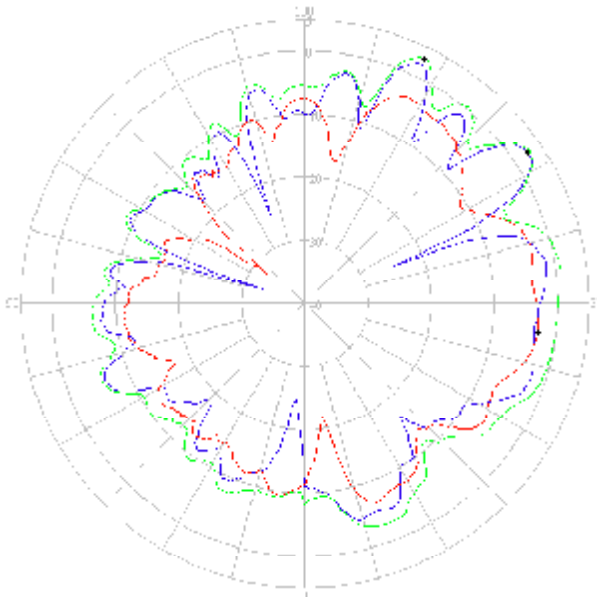

5.725GHz

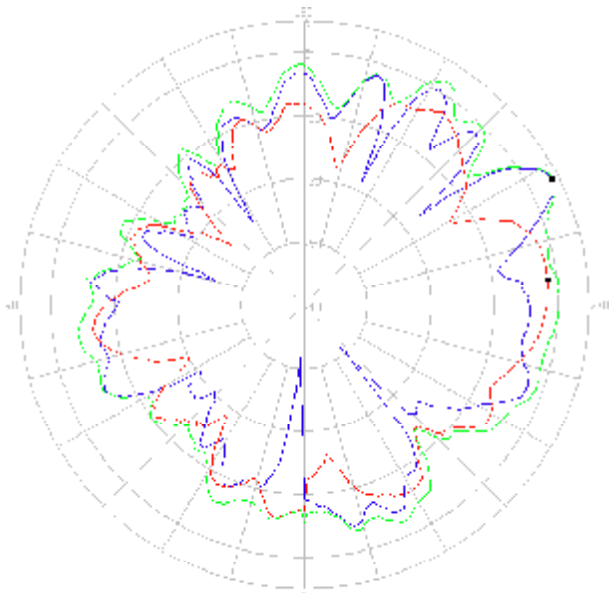

5.785GHz

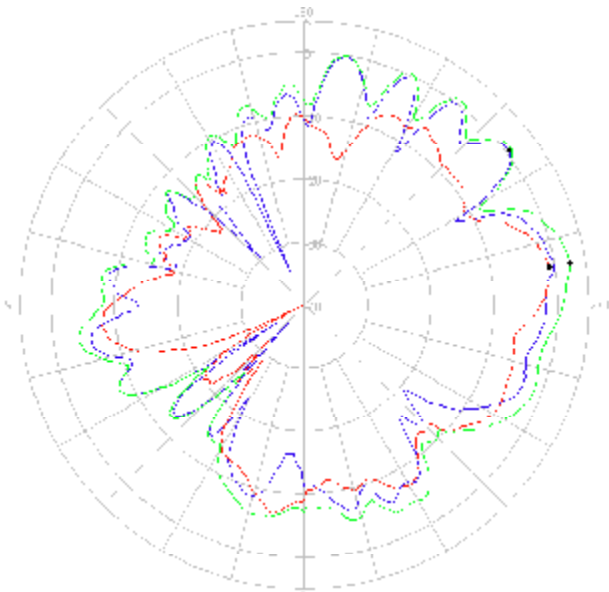

5.85GHz

-  **Horizontal**
-  **Vertical**
-  **H+V**

3.3. Average Gain (dBi) Summary

WLAN Main Antenna Gain						
Frequency	Peak (dBi)			Average (dBi)		
	H-pol	V-pol	Total	H-pol	V-pol	Total
2400 MHz	-0.31	-1.56	1.37	-6.08	-6.46	-3.25
2450 MHz	1.39	-2.43	1.51	-4.91	-6.78	-2.74
2500 MHz	-0.29	-2.50	1.35	-5.54	-7.03	-3.21
5150 MHz	0.90	-1.84	1.57	-5.17	-7.47	-3.16
5250 MHz	0.76	-1.99	1.59	-5.69	-7.80	-3.61
5350 MHz	-0.18	-2.43	1.66	-5.11	-7.22	-3.03
5470 MHz	-0.86	-2.60	0.60	-5.78	-7.62	-3.59
5600 MHz	-0.88	-3.46	0.89	-6.63	-8.47	-4.44
5725 MHz	-0.25	-2.16	1.09	-5.49	-7.83	-3.49
5785 MHz	-0.81	-1.16	1.30	-5.96	-6.95	-3.42
5850 MHz	-0.54	-1.96	0.65	-5.76	-7.96	-3.71

WLAN Aux Antenna Gain						
Frequency	Peak (dBi)			Average (dBi)		
	H-pol	V-pol	Total	H-pol	V-pol	Total
2400 MHz	-0.28	-2.37	1.15	-5.95	-6.63	-3.27
2450 MHz	-0.81	-2.38	0.66	-6.42	-6.95	-3.66
2500 MHz	-0.65	-1.99	0.37	-6.02	-6.91	-3.43
5150 MHz	2.82	-1.46	3.06	-5.73	-7.87	-3.66
5250 MHz	1.30	-0.85	2.42	-5.85	-8.56	-3.99
5350 MHz	1.79	-0.04	2.45	-5.43	-8.48	-3.68
5470 MHz	3.67	-0.92	4.04	-6.49	-8.83	-4.50
5600 MHz	3.14	-2.38	3.14	-6.31	-9.24	-4.52
5725 MHz	2.68	-2.75	3.19	-5.90	-8.42	-3.97
5785 MHz	3.95	-1.15	4.10	-6.06	-7.57	-3.74
5850 MHz	0.55	-0.81	2.56	-6.17	-8.71	-4.25

—

4. Antenna Drawing

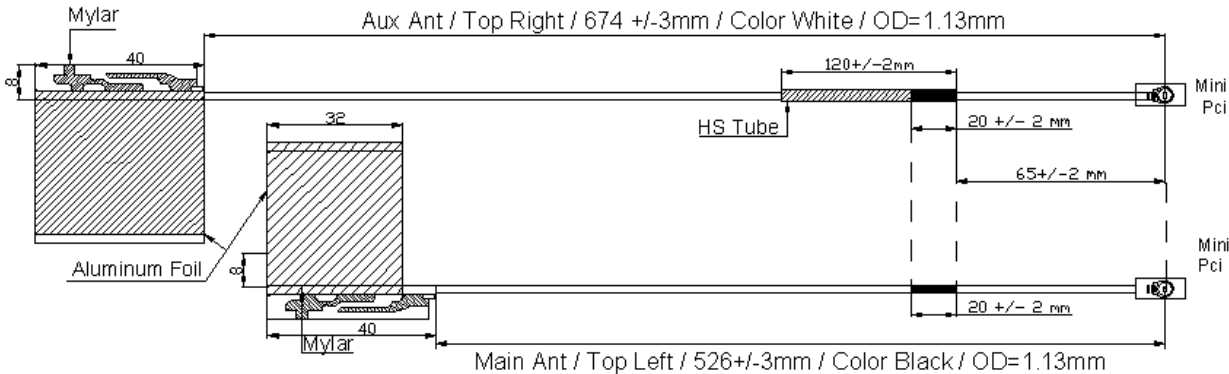

5. Reliability Data For Antenna Patch (Reference To IEC)

IEC 384-10/ CECC 32 100 CLAUSE	IEC 60068-2 TEST METHOD	TEST	PROCEDURE	REQUIREMENTS
4.12	4(Na)	Rapid change of temperature	-40 °C (30 minutes) to +90 °C (30 minutes); 5 cycles	No visible damage Central Freq. Change ± 6%
4.14	3(Ca)	Damp heat	500 ± 12 hours at 40 °C; 90 to 95 % RH	No visible damage 2 hours recovery Central Freq. Change ± 6%
4.15		Endurance	500 ± 12 hours at 90 °C;	No visible damage 2 hours recovery Central Freq. Change ± 6%

6. Ordering Information: Yageo Ordering P/N Code

The antennas may be ordered by using the Yageo P/N ordering code. These code numbers can be determined by the following rules:

CAN4313 7 17 01 250 1B
F C MS T A P

F. Family Code

CAN43 = Antenna

C. Packing Type Code

13 = Bulk (1000 pcs)

M. Materials Code

7 = High Frequency Material

S. Size/Series Code

17 = PEGATRON F80-series(F80L/S/Cr) Antenna

T. Tolerance/Cable

01 = Cable 1 Main + Aux / Black + White, 40*8*0.4mm + 40*8*0.4mm

A. Working Frequency

250 = 2.45/5 GHz for Dual Band

P. Packing

1B = 1000 pcs packing

7. Revision Control

Revision	Date	Content	Remark
R01	Mar. 14, 2008	New Issued, Metal Antenna	N/A.