



<u>REV. NO</u>	<u>MEMO</u>	<u>DATE</u>	<u>REASON</u>
S-1	-----	21/6/04	Preliminary Release

DISTRIBUTION LIST:

Najed Azzam	Yefim Kovarsky
Dor Mussel	Ohad Shavit
Matti Martiskainen	Mauro Grubman
Moshe Weissman	
Corina Pavel	

<u>WRITTEN BY</u>	<u>SIGNATURE</u>	<u>DATE</u>	PAGE 1 OF 13
Ohad Shavit		21.6.04	
Ephraim Kapuliansky		21.06.2004	
<u>APPROVED BY</u>	<u>SIGNATURE</u>	<u>DATE</u>	FORM NO: FM016 REV C
Dor Mussel		21/6/04	



**PRELIMINARY ENGINEERING SPECIFICATION
FOR
ANTENNA M4.5 BASE HELICAL RETRACTABLE
CDMA / AMPS / PCS / GPS
FOR CURITEL TX160C**

GALTRONICS PROJECT: 281300

PART NUMBER: 020678114-2813

2004 © COPYRIGHT GALTRONICS LTD.

This document is issued by Galtronics Ltd. (hereinafter called Galtronics) in confidence, and is not to be reproduced in whole or in part without the prior written permission of Galtronics. The information contained herein is the property of Galtronics and is to be used only for the purpose for which it is submitted and is not to be released in whole or in part without the prior written permission of Galtronics.

**GALTRONICS CONFIDENTIAL AND PROPRIETARY INFORMATION - MAY
NOT BE COPIED OR DISCLOSED.**

Document: 2813SPEC.DOC
Form No.: FM016

Page 2 of 13
Rev C

**ANTENNA SPECIFICATION****CONTENTS**

1. PURPOSE AND SCOPE
2. RELATED DOCUMENTS
3. ABBREVIATIONS AND DEFINITIONS
4. DESCRIPTION AND PART NUMBERS
 - 4.1 Description
 - 4.2 Part Numbers
5. ELECTRICAL SPECIFICATIONS
 - 5.1 Frequency Band
 - 5.2 Impedance
 - 5.3 Matching Requirements
 - 5.4 VSWR
 - 5.4.1 Requirements in Free Space
 - 5.4.2 Test Methods (Engineering)
 - 5.4.3 Test Methods (Production)
 - 5.5 Gain
 - 5.5.1 Gain Values
 - 5.5.2 Test Method
 - 5.6 Power Rating
 - 5.6.1 Requirements
 - 5.6.2 Test Methods
6. MECHANICAL SPECIFICATIONS
 - 6.1 Mechanical Configuration
 - 6.2 Connector Type
 - 6.3 Retraction Forces
 - 6.3.1 Requirements for Initial Values
 - 6.3.2 Test Method
 - 6.4 Pull Test
 - 6.4.1 Requirements
 - 6.4.2 Test Method
 - 6.5 Drop Test
 - 6.6 Helix Torque
 - 6.6.1 Requirements
 - 6.6.2 Test Method
 - 6.7 Helix Bending
 - 6.8 Helix Tensile Load
 - 6.11 Tape Test
7. ENVIRONMENTAL SPECIFICATIONS
 - 7.1 Temperature Cycling
 - 7.2 Salt Spray
 - 7.3 Static Humidity
 - 7.4 Temperature Soak
8. RELIABILITY SPECIFICATIONS
 - 8.1 Connector Reliability
 - 8.2 Whip Bending Endurance
9. QUALIFICATION
10. PACKAGING
11. PRODUCTION SITE
12. QUALIFICATION FLOW CHART



ANTENNA SPECIFICATION

1. PURPOSE AND SCOPE

The purpose of this document is to establish a *design* specification for the antenna product that Galtronics is developing for Curitel, for their wireless handset. This specification is preliminary. Any changes or additions to this specification can affect schedule and/or cost of the product and should be negotiated between Galtronics and Curitel before being incorporated into the specification. Upon agreement of this specification Galtronics will make no changes without the written approval from Curitel. Any changes requested by Curitel will be given to Galtronics with sufficient time to evaluate the cost impact and react as required. The development of the product in Galtronics is conducted according to the Design Control Procedure SOP006E.

2. RELATED DOCUMENTS

- SOP006E Product Launch Procedure (Design Control)
- EN006E Reliability Guidelines
- EIA-STD-556 Outer Shipping Container Bar Code Label Standard

3. ABBREVIATIONS AND DEFINITIONS

- Ω Ohm
- ° Degree
- °C Celsius (degrees Centigrade)
- cm Centimeter
- g Grams
- Hz Hertz
- MHz Megahertz
- m Meter
- mm Millimeter
- N Newton
- PCB Printed Circuit Board
- RH Relative Humidity
- W Watt

Design specification: A preliminary target specification to guide design process

Product specification: A final specification for the qualified product

4. DESCRIPTION AND PART NUMBERS

4.1 DESCRIPTION

This antenna is a base helical retractable for use on a wireless handset. This antenna shall consist of two electromechanical pieces: A whip and a base. The whip shall extend and retract through the center of a fixed base lower helical, which is mounted to the handset via a screw thread interface. The whip element shall function in the full up position and the base helical shall function in the down position.

The electrical, mechanical, and industrial design parameters required for this antenna are described below.

4.2 PART NUMBER

Galtronics Part Number	Frequency Bands
020678114-2813	CDMA / AMPS/PCS/GPS

**ANTENNA SPECIFICATION****5. ELECTRICAL SPECIFICATION****5.1 FREQUENCY BANDS**

Band Name	Frequency Band
CDMA/AMPS	824 - 894 MHz
PCS	1850-1990 MHz
GPS	1575MHz

5.2 IMPEDANCE

Nominal impedance (including matching circuit): 50Ω.

5.3 MATCHING REQUIREMENTS

In order to assure the best performance of the antenna, the matching will be evaluated in free space and in talk position on phantom head for both extended and retracted positions.

The antenna will comply with the Electrical Specification requirements, as set out below, while mounted on the handset containing the PCB. The handset with PCB are to be supplied by the customer and should be representative of the latest design version of all parts. Any modifications in the handset or PCB can affect the performance of the antenna and should be discussed with Galtronics to determine the affect of such changes on antenna performance and delivery requirements.

5.4 VSWR**Requirements in free space**

Band	Extended Position		Retracted Position	
	Tx1	Rx1	Tx1	Rx1
CDMA/AMPS	2.0:1	2.5:1	3.0:1	2.5:1
	Tx2	Rx2	Tx2	Rx2
PCS	3.0:1	2.5:1	3.0:1	3.0:1
GPS	5.0:1		2.5:1	

Transmit Band (Herein designated as **Tx1**) -the frequencies of operation for the Band transmit function shall be **824** to **849** MHz.

Receive Band (Herein designated as **Rx1**) -the frequencies of operation for the Band receive function shall be **869** to **894** MHz.

Transmit Band (Herein designated as **Tx2**) -the frequencies of operation for the Band transmit function shall be **1850** to **1910** MHz.

Receive Band (Herein designated as **Rx2**) -the frequencies of operation for the Band receive function shall be **1930** to **1990** MHz.

Frequency Band for GPS **1575** MHz (Herein designated as **Rx3**)

5.4.2 Test Method (Engineering)

The antenna is tested while mounted to the handset provided by Curitel. The handset is set up with a 50Ω coaxial cable connected to the 50Ω point. Calibration is done at this 50Ω point. The other end of the 50Ω coaxial cable is connected via appropriated quarter wave chokes (AMPS 800, PCS 1900, GPS 1575) to HP network analyzer. The handset is positioned on a non-conductive table for free space measurements.

5.4.3 Test Method (Production)

In mass production it is not practical to use the handset supplied by the customer. A production test fixture will be designed by Galtronics for use on processes requiring electrical testing. The results on the test fixture will be correlated to the



customer handset. Testing in final inspection is done on a statistical basis.

5.5 GAIN

5.5.1 Gain Values (Free Space)

CDMA/AMPS	The beam peak Gain in Azimuth plane	
Mode	Tx, dBi	Rx, dBi
Extended	+2.0	+1.5
Retracted	+0.5	-0.5
PCS	The beam peak Gain in Elevation cuts	
Mode	Tx, dBi	Rx, dBi
Extended	+1.5	+1.5
Retracted	+0.5	0.0
GPS	The beam peak Gain in Elevation cuts	
Mode	Rx, dBi	
Extended	-1.5	
Retracted	-1.0	

5.5.2 Test Method

The antenna is tested while mounted to the handset. The antenna is tested in free space in the anechoic chamber. Radiation patterns are measured at a minimum of 3 different frequencies.

5.6 POWER RATING

5.6.1 Requirements

Maximum value: 1 W

5.6.2 Test Method

The antenna is connected to the handset housing as described in 5.4.2. A power of 1 W is applied to the antenna for a period of 30 min. for extended and retracted position at room temperature (+20°±3°C). The antenna shall satisfy electrical requirements in 5.4.1 after the test and have no visible deterioration.

6. MECHANICAL SPECIFICATIONS

6.1 MECHANICAL CONFIGURATION

The appearance of the antenna is according to drawing 020678114-2813

6.2 CONNECTOR TYPE

The connector type is M4.5X0.5 Threaded Mount Boss.

6.3 RETRACTION FORCES

6.3.1 Requirements for initial values

Position	Force range (N)
F1	0.5-3.5
F2	0.5-5.0
F3	0.5-5.0
F4	0.5-3.5



(See Figure 1 below for definition of F designations)

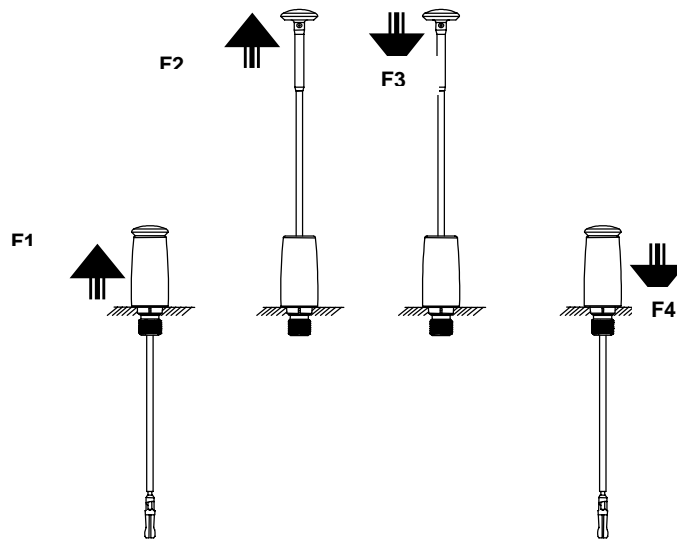

Figure 1. Force Designation for Retraction Forces

6.3.2 Test Method

The antenna is held fixed by the connector and gripped by the antenna cap. The antenna is moved from each position at a speed of 5 mm/s. The maximum force before the antenna is released is recorded. The mean force of 3 measurements for each position shall be within the specified values in 6.3.1.

6.4 PULL TEST

6.4.1 Requirement

50 N axial pull force for 30 seconds.

6.4.2 Test Method

With the antenna connector mounted in an appropriate test fixture, apply axial tension load 50 N along the longitude axis to the antenna cap during 30 seconds Whip element fully extended. The sample is subjected to visual checking as well as to checking of electrical and mechanical working characteristics and must not have suffered from irreversible mechanical and electrical damage.

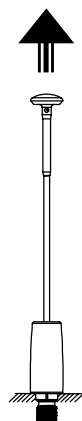

Figure 2. Method for Pull Strength Measurement



6.5 DROP

The antenna attached to a dummy weighted radio (100 grams) should withstand 2 drops directed towards the antenna onto a metal surface. The drop height is 1.5m. The first drop shall be executed in the retracted position and second drop in the extended position. The antenna shall satisfy the electrical specifications in 5.4.1 after the test. The antenna should function mechanically after the test. The antenna can be physically straightened at the end of the test. Temperature of the environment $+24^{\circ}\text{C} \pm 3^{\circ}\text{C}$.

6.6 HELIX TORQUE

6.6.1 Requirements

No electrical or mechanical deformation is admitted when the helical is turned with a torque of 30 Ncm

6.6.2 Test Method

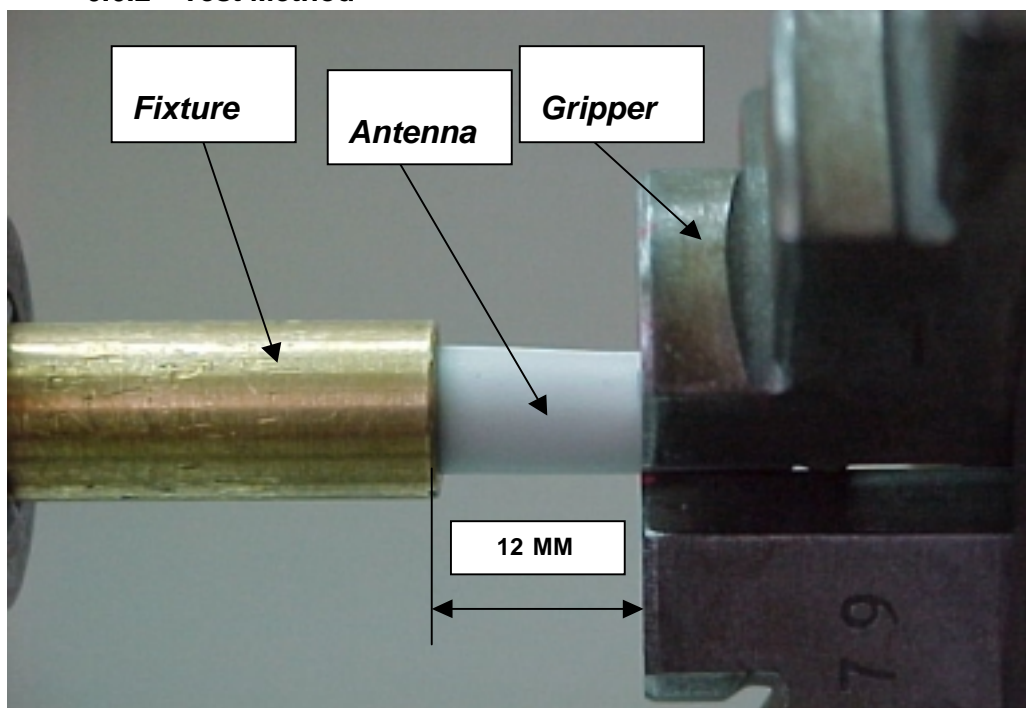

Figure 3. Method for Torque Measurement

The Torque Gauge element of the Measured device fits the simulator of the telephone fixture (Figure 3). The simulator is attached to the torque measuring device. Antenna with the fully inserted whip should be fitted to the fixture that simulates dimensions of the antenna set in the radio case. The gripper clamps the antenna base helical at distance of 12 mm from the simulator of the telephone fixture. The initial fit moment should be $10.0 \text{ Ncm} \pm 1 \text{ Ncm}$. Then the handle of the gripper should be rotated in the CW direction until the additional moment of 20.0 Ncm is generated.

No loosening of joints between details of the antenna should be revealed after the test. The antenna shall satisfy the electrical specifications in 5.4.1 after the test.



ANTENNA SPECIFICATION

6.7 HELIX BENDING

With the antenna connector mounted in an appropriate test fixture, apply lateral load 40 N to the helix with bend of helix no more than 30°. Whip element inserted. The sample is subjected to visual checking as well as to checking of electrical and mechanical working characteristics and must not have suffered from irreversible mechanical and electrical damage.

6.8 HELIX TENSILE LOAD

With the antenna connector mounted in an appropriate test fixture, apply axial tension load 50 N along the longitude axis to the helix. Whip element inserted. The sample is subjected to visual checking as well as to checking of electrical and mechanical working characteristics and must not have suffered from irreversible mechanical and electrical damage.

6.9 TAPE TEST

Adhere Cello Tape (width 50mm, length 50-100mm, adhesion force 240-400 grams) onto Cr plated cap of antenna, and then take off it in fast speed while maintaining 15 degree 5 times repeatedly. Pass condition: Plating condition should be the same as original one. Any pieces of plating should not be adhered on the tape.

7. ENVIRONMENTAL SPECIFICATIONS**7.1 TEMPERATURE CYCLING**

Place complete antenna in an environmental chamber at temperature T1= -40°C. Expose antenna to this temperature during 60 minutes. Then increase temperature to value of T2= +85°C during 30 minutes and soak at this temperature during 60 minutes. Relative Humidity must be 50% RH. Repeat this cycle 24 times. After test is complete: soak samples for 4 hours at room temperature. There shall be no visual deterioration or damage. Electrical characteristics should be within the specified range.

7.2 SALT SPRAY

Place complete antenna in Salt Spray Cabinet at temperature +35°C with the salt fog of NaCl solution (5%); soak time - 48 hours.

After test is complete: soak samples for 4 hours at room temperature. There shall be no visual degradation in esthetical and mechanical performance. Electrical characteristics should be within the specified range.

7.3 STATIC HUMIDITY

Place complete antenna in an environmental chamber at +20°C. Increase temperature with speed 1° per minute to +55° C with humidity increasing to 95% RH during 2 hours. Soak antenna with these parameters for 24 hours. After the finish initial ambient parameters should be achieved during 1 hour.

After test is complete: soak samples for 4 hours at room temperature. There shall be no visual degradation in esthetical and mechanical performance. Electrical characteristics should be within the specified range.



ANTENNA SPECIFICATION

7.4 TEMPERATURE SOAK

The antenna to be subjected to the high temperature soak at +85°C for 48 hours and to low temperature soak at -40°C for 48 hours.

After test is complete: soak samples for 4 hours at room temperature. There shall be no visual degradation. Electrical characteristics should be within the specified range.

8. RELIABILITY SPECIFICATIONS

8.1 CONNECTOR RELIABILITY

The antenna shall withstand 20,000 retraction cycles. The antenna should be rotated periodically during the test. After testing the retraction forces should not be less than 50 grams.

8.2 WHIP BENDING ENDURANCE

With the antenna mounted in an appropriate test fixture, cycle the whip left/right 90° to the vertical 1000 times at a rate of 20-30 cycles/min.

Conditions: At +25° C, Whip element extended.

The sample is subjected to visual checking as well as to checking of electrical and mechanical working characteristics and must not have suffered from irreversible mechanical and electrical damage.

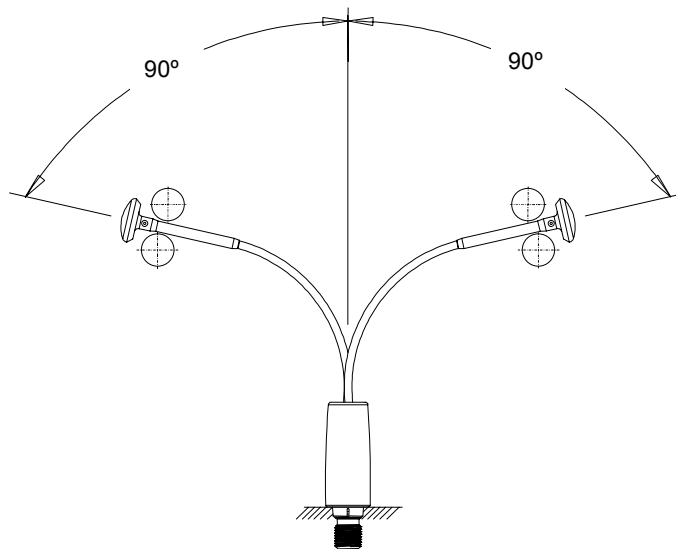

Figure 4. Method for Whip Bending Endurance Testing

9. QUALIFICATION

The mechanical, environmental and reliability tests mentioned above are performed according to the flow chart shown in Figure 5 below. The entire testing procedure will be conducted according to EN006E. A summary report of the results of the tests will be sent to the customer. Galtronics will not start mass production until the customer will grant the product a qualified status.

**ANTENNA SPECIFICATION****10. PACKAGING**

The antennas will be packed in compartmentalized vacuum-formed trays. There are 40 antennas per tray. (See Appendix) The trays are packed in a corrugated fiberboard over box, 32 trays per box. The over box will be labeled for shipping according to the standards outlined in EIA-STD-556 (See Figure 7).

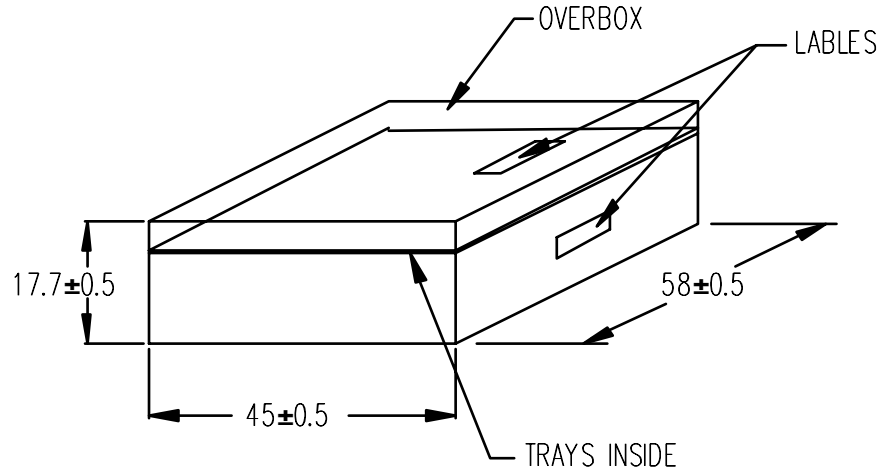

Figure 7. Packaging (dimensions of overbox in cm)

The labels should provide following information:

- Supplier's Address;
- Customer's Address;
- Package Count;
- Package Weight;
- Ship Date;
- Ship Number;
- Sales Order Number;
- Vendor's Part Number;
- Package Identification (Bar Code);
- Special (Bar Code);
- Total Quantity (Bar Code);
- Transaction Identification (Bar Code);
- Customer Product Identification (Bar Code).

11. PRODUCTION SITE

Galtronics Israel will manufacture the antennas.

Address: P.O.Box 1589, Tiberias, Israel

Tel: 972-4-6739777

Fax: 972-4-6732037

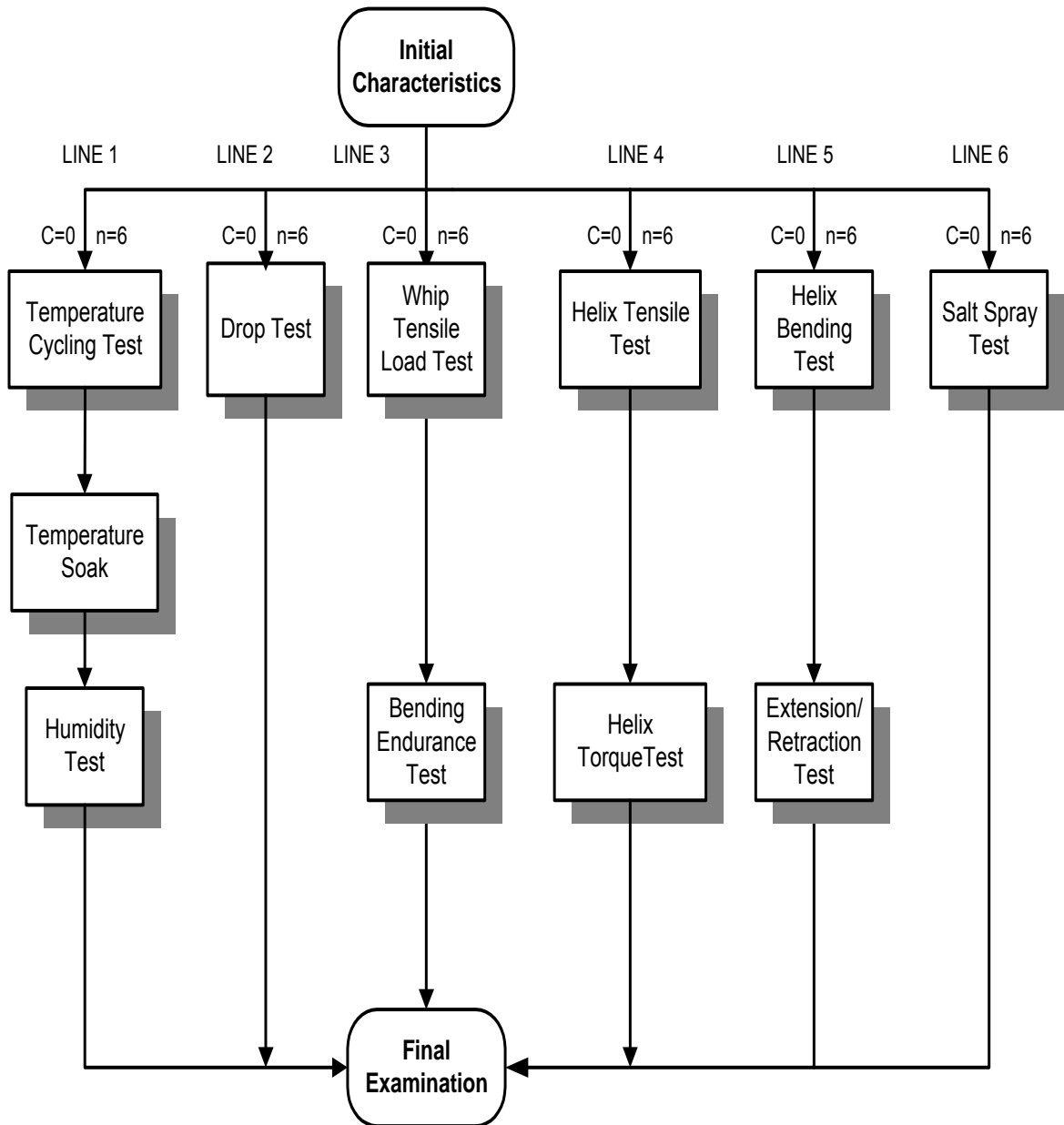

Figure 5. Qualification Flow Chart

Allowed amount of failures after every test line c=0; Sample size n=6



ANTENNA SPECIFICATION

APPENDIX

