



VERIFICATION

HYUNDAI CURITEL INC.
SAN 136-1, AMI-RI , BUBAL-EUP, ICHEON-SI,
KYOUNGKI-DO, 467-701, KOREA

FRN: 0006-2784-69

Date of Issue : February 27, 2004

Test Report No.: HCT-SAR04-0206

Test Site: HYUNDAI CALIBRATION & CERTIFICATION
TECHNOLOGIES CO., LTD.

FRN: 0005866421

FCC ID :

PP4TX-130C

MODEL :

TX-130C

FCC Rule Part(s): Part 15 & 2
Standard(s): FCC Class B: 2001 (CISPR 22: 1998)
FCC Classification: Licensed Portable Transmitter Held to Ear (PCE)
Equipment(EUT) Type: Dual-Mode CDMA Phone (CDMA/ PCS CDMA)
Trade Name/Model(s): HYUNDAI / TX-130C
Port/ Connector(s) DC Input Port, Ear Phone Port

The device bearing the trade name and model specified above, has been shown to comply with the applicable technical standards as indicated in the measurement report and was tested in accordance with the measurement procedures specified in ANSI C63.4-1992.(See Test Report if any modifications were made for compliance)

I attest to the accuracy of data. All measurements reported herein were performed by me or were made under my supervision and are correct to the best of my knowledge and belief. I assume full responsibility for the completeness of these measurements and vouch for the qualifications of all persons taking them.

HYUNDAI C-Tech. certifies that no party to application has been denied the FCC benefits pursuant to Section 5301 of the Anti-Drug Abuse of 1988,21 U.S.C.853(a).

Ki Soo Kim

Report prepared by : Ki-Soo Kim
Manager of Product Compliance Team



TABLE OF CONTENTS

	PAGE
1. GENERAL INFORMATION.....	3
1.1 Product Description.....	3
1.2 Related submittal(s)/Grant(s).....	3
1.3 Tested System Details.....	4
1.4 Test Methodology.....	4
1.5 Test Facility.....	4
2. SYSTEM TEST CONFIGURATION.....	5
2.1 Justification.....	5
2.2 EUT Exercise Software.....	5
2.3 Cable Description.....	6
2.4 Noise Suppression Parts on Cable.....	6
2.5 Equipment Modifications.....	7
2.6 Configuration of Tested System.....	8
3. PRELIMINARY TESTS.....	9
3.1 Power line Conducted Emissions Tests.....	9
3.2 Radiated Emissions Tests.....	9
4. FINAL CONDUCTED AND RADIATED EMISSION TESTS SUMMARY.....	10
4.1 Conducted Emission Tests.....	10-12
4.2 Radiated Emission Tests.....	13
4.3 Test Setup Photos.....	14-15
5. FIELD STRENGTH CALCULATION.....	16

1. GENERAL INFORMATION

1.1 Product Description

The Hyundai Curitel TX-130C Dual-Mode (CDMA/ PCS CDMA) phone. Its basic purpose is used for communications. It transmits from CDMA(824.70~848.31), PCS CDMA(1851.25~1908.75)MHz and receives from CDMA(869.70~893.31), PCS CDMA(1931.25~1988.75)MHz. The RF power is rated at CDMA(0.331W), PCS CDMA(0.344W).

FCC ID	PP4TX-130C
EUT Type	Dual-Mode CDMA Phone (CDMA/ PCS CDMA)
Model	HYUNDAI
TX Frequency	824.70 — 848.31 MHz (CDMA) 1851.25 — 1908.75 MHz (PCS CDMA)
RX Frequency	869.70 — 893.31 MHz (CDMA) 1931.25 — 1988.75 MHz (PCS CDMA)
FCC Classification	Licensed Portable Transmitter Held to Ear (PCE)
Max RF. Output Power	0.331W ERP CDMA (25.20dBm) 0.344W EIRP PCS CDMA (25.37dBm)
Modulation	CDMA

1.2 Related Submittal(s) / Grant(s)

ORIGINAL SUBMITTAL ONLY

1.3 Tested System Details

The Model names for all equipment, plus descriptions used in the tested system (including inserted cards) are:

DEVICE TYPE	MANUFACTURER	MODEL NUMBER	FCC ID / DoC	CONNECTED TO
Dual-Mode CDMA Phone (CDMA/ PCS CDMA)	HYUNDAI CURITEL INC.	TX-130C	PP4TX-130C	CHARGER
CHARGER	HYUNDAI CURITEL INC.	CNR4	-	EUT
Head-Set	HYUNDAI CURITEL INC.	-	-	EUT
P.C	Compaq	LDWZ	DoC	N/A
MONITOR	Cornea	CT1502	PL4CT1502	P.C
Adapter	Lishin international Enterprise Corp	LSE9901B1260	DoC	MONITOR
KEY BOARD	H.P	5181	DoC	P.C
MOUSE	H.P	M-S48a	DoC	P.C
PRINTER	H/P	C4569A	DoC	P.C

1.4 Test Methodology

Both conducted and radiated testing were performed according to the procedures in ANSI C63.4/1992. Radiated testing was performed at an antenna to EUT distance of 10 meters.

1.5 Test Facility

The open area test site and conducted measurement facility used to collect the radiated data are located at the 254-1, Maekok-Ri, Hobup-Myun, Ichon-Si, Kyoungki-Do, 467-701, KOREA. The site is constructed in conformance with the requirements of ANSI C63.4 and CISPR Publication 22. Detailed description of test facility was submitted to the Commission and accepted dated July 23, 2003(Confirmation Number: EA90661)

2.SYSTEM TEST CONFIGURATION

2.1 Justification

The device was configured for testing in a typical fashion (as a customer would normally use it). During the tests, the following components and I/O cards inside the E.U.T were used.

DEVICE TYPE	MANUFACTURE	MODEL/PART NUMBER
MAIN BOARD	HYUNDAI CURITEL INC.	TX-130C

2.2 EUT exercise Software

The EUT was tested on the charging battery during the radiated and conducted emission testing.

2.3 Cable Description

The marked "(D)" means the Data Cable and "(P)" means the Power Cable.

	Power Cord Shielded (Y/N)	I/O Cable Shielded (Y/N)	Length (M)
EUT	N/A	Y	1.5(D)
Charger	N	N/A	1.5(P)
MONITOR	N	Y	1.8(P), 1.5(D)
Adaptor	N	N/A	1.8(P)
PC	N	N/A	1.8(P)
KEY BOARD	N/A	Y	1.8(D)
Head-Set	N/A	N	1.5(D)
MOUSE	N/A	Y	1.8(D)
PRINTER	N	Y	1.8(P),1.8(D)

2.4 Noise Suppression Parts on Cable.

	Ferrite Bead (Y/N)	Location	Metal Hood (Y/N)	Location
EUT	Y	P.C END	Y	PC END
Charger	N	N/A	N	EUT END
MONITOR	Y	P.C END	Y	P.C END
Adaptor	Y	Adaptor END	Y	MONITOR END
KEY BOARD	N	N/A	Y	P.C END
Head-Set	N	N/A	N	P.C END
MOUSE	N	N/A	Y	P.C END
PRINTER	N	N/A	Y	P.C END

2.5 Equipment Modifications

N/A

2.6 Configuration of Test system

Line Conducted Test : EUT was connected to LISN, all other supporting equipment were connected to another LISN. Preliminary Power line Conducted Emission tests were performed by using the procedure in ANSI C63.4/1992 7.2.3 to determine the worse operating conditions.

Radiated Emission Test : Preliminary Radiated Emissions tests were conducted using the procedure in ANSI C63.4/1992 8.3.1.1 to determine the worse perating condition. Final Radiated Emission tests were conducted at 10 meter open area test site.

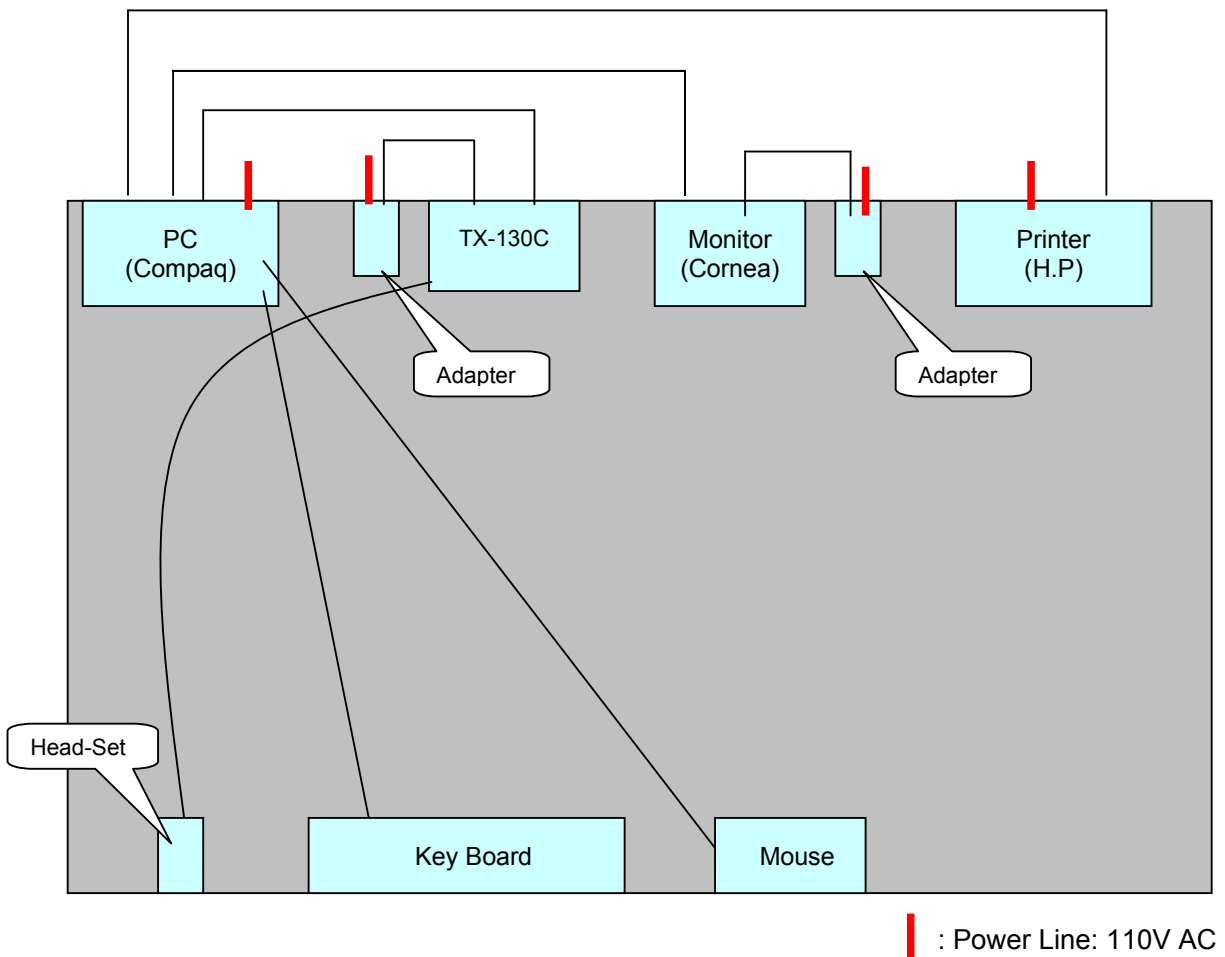

[Configuration of Tested System]

3. PRELIMINARY TESTS

3.1 AC Power line Conducted Emission Tests

During Preliminary Tests, the following operating mode were investigated

Model	Operating Mode	The worst operating condition
TX-130C	Charging	X
	Standby	
	PC Camera up/down load	

3.2 Radiated Emission Tests

During Preliminary Tests, Charging battery mode were investigated.

Model	Operating Mode	The worst operating condition
TX-130C	Charging	X
	Standby	
	PC Camera up/down load	

4. FINAL CONDUCTED AND RADIATED EMISSION TESTS SUMMARY

4.1 Conducted Emissions Tests

The following table shows the highest levels of conducted emissions on both polarization of hot and neutral line.

```

=====
Humidity Level      : 32%                Temperature : 20.2°C
Limit apply to     : FCC CFR 47, PART 15, SUBPART B
Type of Tests      : CISPR 22 CLASS B
Date               : February 20, 2004
Result            : PASSED BY -15.8 dB
EUT               : TX-130C
Operating Condition : CHARGING BATTERY
Detector          : CISPR Quasi-Peak (6 dB Bandwidth : 9 KHz)
  
```

Power Line Conducted Emissions				FCC Class B	
Frequency (MHz)	Amplitude (dBuV)	Conductor	Result	Limit (dBuV)	Margin (dB)
3.225	40.2	NEUTRAL	Quasi-Peak	56	-15.8
0.385	29.8	NEUTRAL	Average	48	-18.4
6.93	40.3	HOT	Quasi-Peak	60	-19.7
0.385	28.3	HOT	Average	48	-19.9

Line Conducted Emissions Tabulated Data

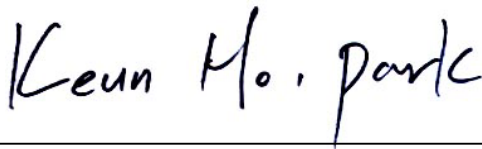

Measured by : Keun-Ho Park / Engineer

Date : February 20, 2004

**HYUNDAI C-TECH
EMC TESTING Laboratory**

EUT: TX-130C
 Manufacturer: Hyundai Curitel Inc.
 Operating Condition: charging
 Test Site: SHIELD ROOM
 Operator: Keun-Ho Park
 Test Specification: CISPR 22 CLASS B
 Comment: H

SCAN TABLE: "CISPR 22 Voltage"

Short Description:			CISPR 22 Voltage			
Start Frequency	Stop Frequency	Step Width	Detector	Meas. Time	IF Bandw.	Transducer
150.0 kHz	500.0 kHz	5.0 kHz	MaxPeak	10.0 ms	9 kHz	None
			Average			
500.0 kHz	5.0 MHz	5.0 kHz	MaxPeak	10.0 ms	9 kHz	None
			Average			

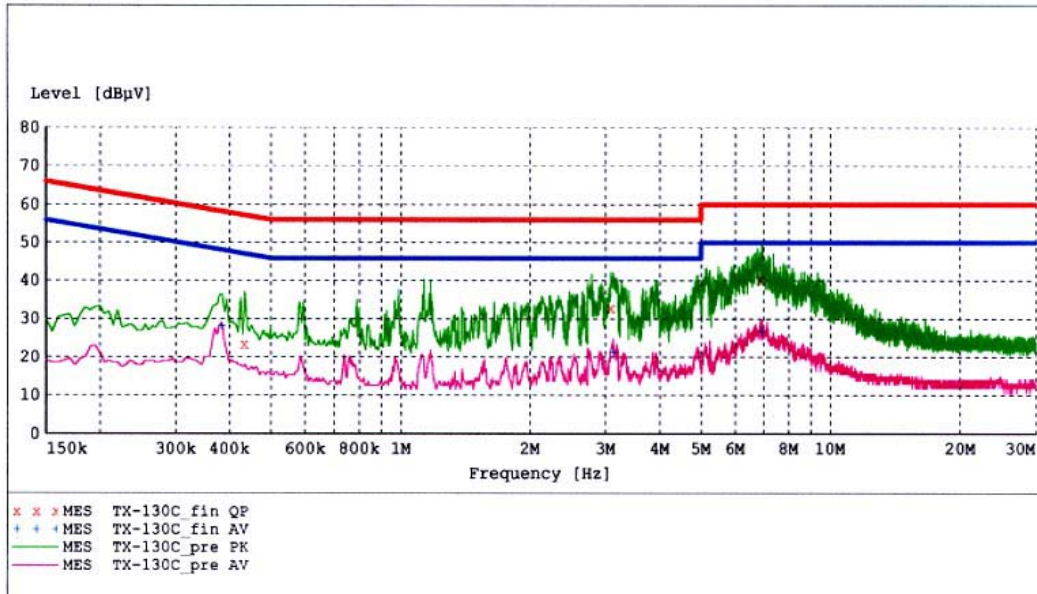

MEASUREMENT RESULT: "TX-130C_fin_QP"

Frequency MHz	Level dBµV	Transd dB	Limit dBµV	Margin dB	Line
0.435000	23.50	10.1	57	33.7	1
3.090000	32.80	10.2	56	23.2	1
6.930000	40.30	10.3	60	19.7	1

MEASUREMENT RESULT: "TX-130C_fin_AV"

Frequency MHz	Level dBµV	Transd dB	Limit dBµV	Margin dB	Line
0.385000	28.30	10.1	48	19.9	1
3.120000	21.40	10.2	46	24.6	1
6.930000	26.80	10.3	50	23.2	1

**HYUNDAI C-TECH
EMC TESTING Laboratory**

EUT: TX-130C
 Manufacturer: Hyundai Curitel Inc.
 Operating Condition: charging
 Test Site: SHIELD ROOM
 Operator: Keun-Ho Park
 Test Specification: CISPR 22 CLASS B
 Comment: N

SCAN TABLE: "CISPR 22 Voltage"

Short Description:			CISPR 22 Voltage			
Start Frequency	Stop Frequency	Step Width	Detector	Meas. Time	IF Bandw.	Transducer
150.0 kHz	500.0 kHz	5.0 kHz	MaxPeak	10.0 ms	9 kHz	None
			Average			
500.0 kHz	5.0 MHz	5.0 kHz	MaxPeak	10.0 ms	9 kHz	None
			Average			

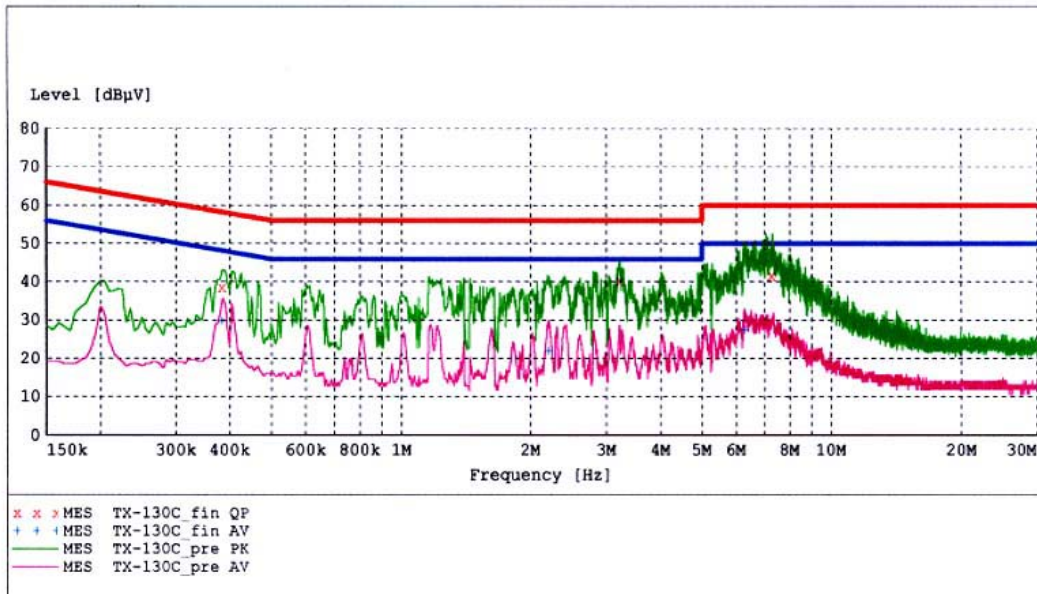

MEASUREMENT RESULT: "TX-130C_fin QP"

Frequency MHz	Level dBµV	Transd dB	Limit dBµV	Margin dB	Line
0.385000	38.50	10.1	58	19.7	1
3.225000	40.20	10.2	56	15.8	1
7.280000	41.50	10.3	60	18.5	1

MEASUREMENT RESULT: "TX-130C_fin AV"

Frequency MHz	Level dBµV	Transd dB	Limit dBµV	Margin dB	Line
0.385000	29.80	10.1	48	18.4	1
2.200000	21.90	10.3	46	24.1	1
6.295000	27.40	10.3	50	22.6	1

4.2 Radiated Emissions Tests

The following table shows the highest levels of Radiated Emissions on both polarization of horizontal and vertical.

```

=====
Humidity Level      : 30 %                Temperature : 21.0°C
Limit apply to     : FCC CFR 47, PART 15, SUBPART B
Type of Tests      : CISPR 22 CLASS B
Date               : February 20, 2004
Result            : PASSED BY -5.2 dB
EUT               : TX-130C
Operating Condition : Charging Battery
Detector          : CISPR Quasi-Peak (6 dB Bandwidth : 120 KHz)
  
```

Frequency MHz	Reading dBuV	Ant. Factor dB	Cable Loss dB	ANT POL (H/V)	Total dBuV/m	Limit dBuV/m	Margin dB
34.2	6.23	17.29	1.3	V	24.8	30	-5.2
89.5	13.41	8.70	2.1	V	24.2	30	-5.8
126.4	6.95	13.35	2.6	V	22.9	30	-7.1
229.3	2.61	17.06	3.4	V	23.1	30	-6.9
351.4	6.44	16.45	4.3	V	27.2	37	-9.8
369.7	6.35	16.63	4.4	V	27.4	37	-9.6
158.6	3.39	15.35	2.9	H	21.6	30	-8.4
218.7	3.47	16.79	3.3	H	23.6	30	-6.4
326.5	7.60	16.35	4.2	H	28.1	37	-8.9
349.8	6.17	16.44	4.3	H	26.9	37	-10.1
512.3	2.86	19.38	5.2	H	27.4	37	-9.6
554.6	2.63	20.30	5.4	H	28.3	37	-8.7



Measured by : Keun-Ho Park / Engineer

Date : February 20, 2004

4.3 Test Setup Photos

4.3.1 Conducted Radiated Emission

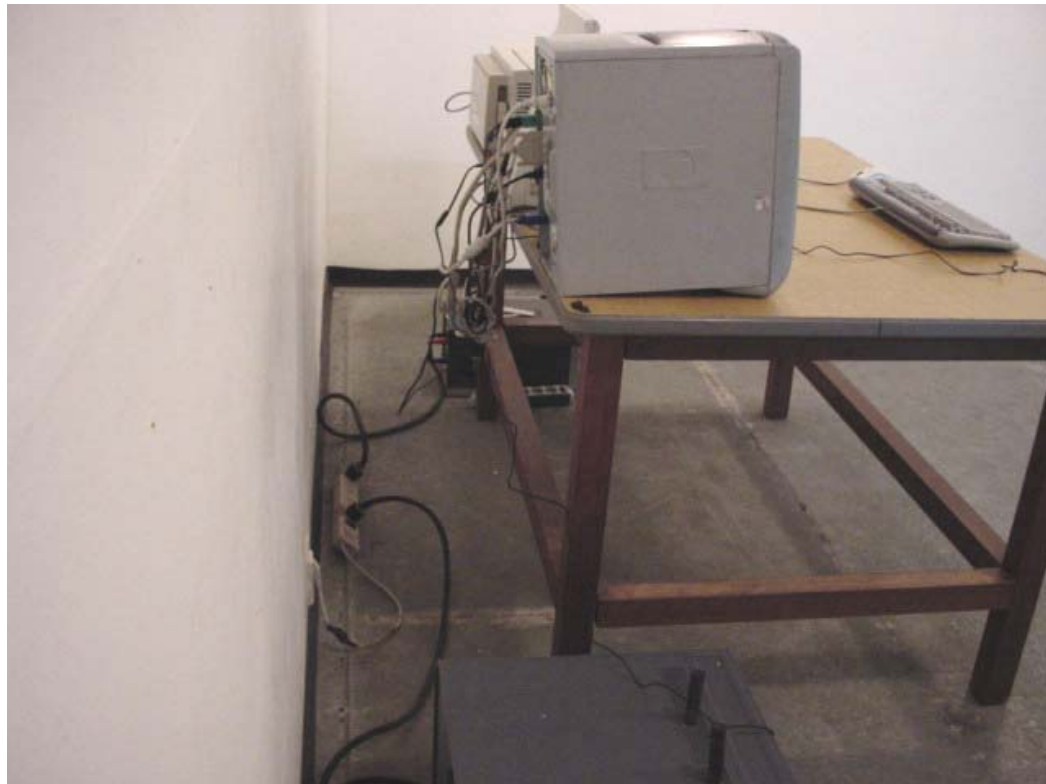

4.3.2 Radiated Emission



5. Field Strength Calculation

The field strength is calculated by adding the Antenna Factor and Cable Factor.
The basic equation with a sample calculation is as follows:

$$FS = RA + AF + CF$$

where FS = Field Strength

RA = Receiver Amplitude

AF = Antenna Factor

CF = Cable Attenuation Factor

Assume a receiver reading of 21.5 dBuV is obtained. The Antenna Factor of 7.4 and a Cable Factor of 1.1 is added. The 30 dBuV/m value was mathematically converted to its corresponding level in uV/m.

$$FS = 21.5 + 7.4 + 1.1 = 30 \text{ dBuV/m}$$

$$\text{Level in uV/m} = \text{Common Antilogarithm} [(30 \text{ dBuV/m})/20] = 31.6 \text{ uV/m}$$