

CURITEL TX110C

APPROVAL SHEET

PRODUCT	ANTENNA
TYPE	BASE HELICAL RETRACTABLE STUD M4.5 CDMA / GPS / PCS CURITEL TX110C
GALTRONICS P/N	020678114-2372
PRODUCT DRAWING	Rev. S-1
ANTENNA SPECIFICATION	Rev. S-1

CUSTOMER ACCEPTANCE

CURITEL	
----------------	--

SUPPLIER:

GALTRONICS LTD
P.O. Box 1589
Tiberias 14115
ISRAEL
TEL: 972-4-6739777
FAX: 972-4-6734138

AGENCY:

TRUCO INC.
6F, Chohung bank B/D,
Kwanyang-dong, Anyang-city
Kyungki-do, KOREA 431-060
TEL: 82-31-387-4200
FAX: 82-31-387-0063

RF ENGINEER CHECKED	MECHANICAL ENGINEER CHECKED	PRODUCT MANAGER CHECKED
<i>Michael Sima</i>	<i>ANATOLY Berezin</i>	<i>DOR WSSCL</i>
<i>09.12.2003</i>	<i>9.12.2003</i>	<i>9/12/03</i>

DWG No
020678114-2372



GALTRONICS

DRAWING COVER SHEET

REV	ISSUE DATE	ECO #	DESCRIPTION
S-1	27/09/2003	11340	Released for Samples

APPLICABLE SPEC'S:

SURFACE FINISH, MICROMETERS, CLA (UNLESS STATED) 0.8
 TOLERANCES UNLESS OTHERWISE SPECIFIED:
 NO PLACE (X)± TWO PLACE (X.XX)±0.1
 ONE PLACE (X.X)±0.2 THREE PLACE (X.XXX)±0.05

- INTERNAL DISTRIBUTION**
- PROCESS
 - PURCHASING
 - PRODUCTION
 - PLASTICS
 - QUALITY
 - INCOMING INSPECTION
 - FINAL INSPECTION
 - MARKETING

METRIC SCREW THREAD TO ISO STANDARDS 724, 2861, 965-1 AND 965-2 INCHES SCREW THREAD TO ANSI/ASME B1.1. ALL ANGLES TO BE 90° UNLESS OTHERWISE STATED. TOLERANCE ON ANGLES ±/4°. ALL TOLERANCES APPLY AFTER FINISHING. MACHINE CORNER RADS, 0.25 MAX., TO BE FREE FROM BURRS, SHARP EDGES AND ALL FOREIGN MATERIALS. FLASH ALLOWANCE FOR PLASTIC MOLDED PARTS TO BE 0.1mm UNLESS OTHERWISE STATED. DIAMETER MUST BE CONCENTRIC WITHIN 0.08 T.I.R..

QUALITY ASSURANCE NOTES:
 NO CHANGE SHALL BE ALLOWED ON PRODUCTION. MATERIAL WITHOUT PRIOR EXPLICIT WRITTEN APPROVAL BY GALTRONICS ENGINEERING AND PURCHASING DEPARTMENTS FOR SPECIAL REQUIREMENTS SEE FMI49

- XR PROCESS CONTROL CHART REQUIRED WITH EACH SHIPMENT)
- CRITICAL DIMENSION AFFECTS FORM FIT OR FUNCTION

SUFFIX #	DESCRIPTION
2372	CURITEL TX110C

MATERIAL
 FINISH

© GALTRONICS LTD.2003
 THE DRAWING AND INFORMATION ON THIS PRINT ARE GALTRONICS - CONFIDENTIAL AND PROPRIETARY INFORMATION - MAY NOT BE COPIED OR DISCLOSED

TITLE:
**ANTENNA STUD M4.5
 CDMA/GPS/PCS
 CURITEL TX110C**

CHKD: *[Signature]*
 APRVD: *[Signature]*
 DATE: 29.09.2003

DWG. No. **020678114-2372**

REV. **S1** PAGE 1 OF 2

ALL DIMENSIONS IN MILLIMETERS UNLESS OTHERWISE STATED. DO NOT SCALE - IF IN DOUBT, ASK!! SEE COVER SHEET FOR PERTINENT INFORMATION

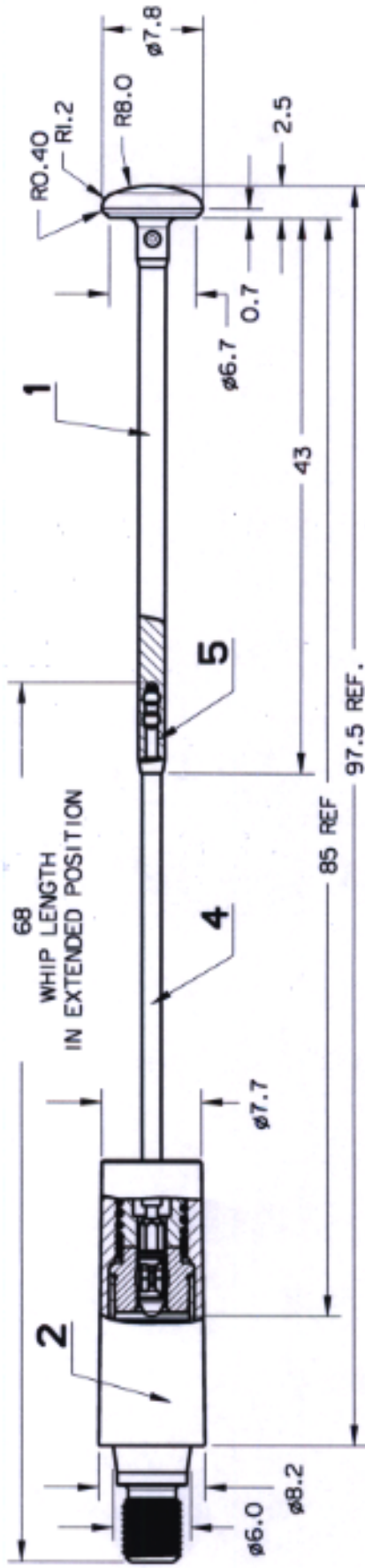
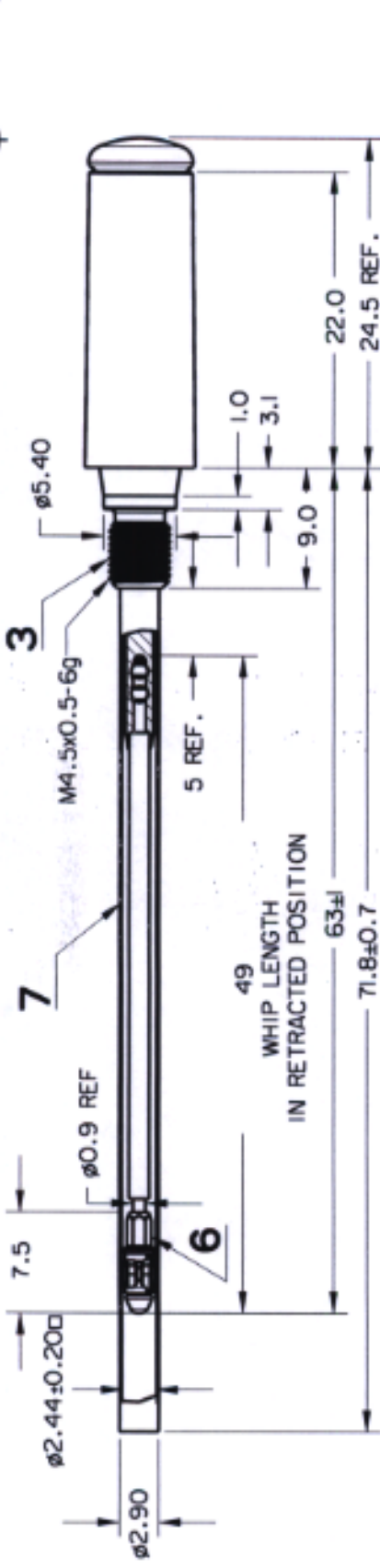

7	Polypropylene	Color: Black
6	Free Cutting Brass ISO CuZn39Pb9 (MS 58A)	Nickel Plating
5	Ni-Ti-Cr Super Elastic Alloy	
4	Plastic: Polyurethane-Shore 40D	Color: T.B.D.
3	Free Cutting Brass ISO CuZn39Pb9 (MS 58A)	Nickel Plating
2	Plastic: Polyurethane Shore 64D	Color: T.B.D.
1	Plastic: Nylon 6/6	Color: T.B.D.
NO	MATERIAL	FINISH

CAD FILE: 020678075-2392-DOWN



THIS PRINT IS GALTRONICS CONFIDENTIAL

ENGINEER	ArB	CHECKED	<i>Speed</i>
DRAWN	MB	APPVD.	<i>ArB 29.9.07</i>
DATE	27.09.03	DATE	<i>29.09.03</i>

ANTENNA STUD M4.5
CDMA/GPS/PCS
CURITEL TX110C

DWG. NO.: A3 REV.
020678114-2372
 SI

GALTRONICS CONFIDENTIAL PROPRIETARY INFORMATION - MAY NOT BE COPIED OR DISCLOSED

PAGE 2 OF 2



<u>REV. NO</u>	<u>MEMO</u>	<u>DATE</u>	<u>REASON</u>
S-1	-----	9/12/03	Preliminary Release

DISTRIBUTION LIST:

Mike Elliott	Yefim Kovarsky
Matti Martiskainen	Anatoly Berezin
Dor Mussel	Mauro Grubman
Moshe Weissman	
Corina Pavel	

<u>WRITTEN BY</u>	<u>SIGNATURE</u>	<u>DATE</u>	PAGE 1 OF 12
Anatoly Berezin	<i>Hub</i>	9.12.03	
Michael Sima	<i>[Signature]</i>	09.12.03	
<u>APPROVED BY</u>	<u>SIGNATURE</u>	<u>DATE</u>	FORM No: FM016 REV C
Dor Mussel	<i>[Signature]</i>	9/12/03	

ANTENNA SPECIFICATION

**PRELIMINARY DESIGN SPECIFICATION
FOR
ANTENNA M4.5 BASE HELICAL RETRACTABLE
CDMA / GPS / PCS
FOR CURITEL TX110C**

GALTRONICS PROJECT: 237200

PART NUMBER: 020678114-2372

2003 © COPYRIGHT GALTRONICS LTD.

This document is issued by Galtronics Ltd. (hereinafter called Galtronics) in confidence, and is not to be reproduced in whole or in part without the prior written permission of Galtronics. The information contained herein is the property of Galtronics and is to be used only for the purpose for which it is submitted and is not to be released in whole or in part without the prior written permission of Galtronics.

**GALTRONICS CONFIDENTIAL AND PROPRIETARY INFORMATION - MAY NOT BE
COPIED OR DISCLOSED.**

**ANTENNA SPECIFICATION****CONTENTS**

1. PURPOSE AND SCOPE
2. RELATED DOCUMENTS
3. ABBREVIATIONS AND DEFINITIONS
4. DESCRIPTION AND PART NUMBERS
 - 4.1 Description
 - 4.2 Part Numbers
5. ELECTRICAL SPECIFICATIONS
 - 5.1 Frequency Band
 - 5.2 Impedance
 - 5.3 Matching Requirements
 - 5.4 VSWR
 - 5.4.1 Requirements in Free Space
 - 5.4.2 Test Methods (Engineering)
 - 5.4.3 Test Methods (Production)
 - 5.5 Gain
 - 5.5.1 Gain Values
 - 5.5.2 Test Method
 - 5.6 Power Rating
 - 5.6.1 Requirements
 - 5.6.2 Test Methods
6. MECHANICAL SPECIFICATIONS
 - 6.1 Mechanical Configuration
 - 6.2 Connector Type
 - 6.3 Retraction Forces
 - 6.3.1 Requirements for Initial Values
 - 6.3.2 Test Method
 - 6.4 Pull Test
 - 6.4.1 Requirements
 - 6.4.2 Test Method
 - 6.5 Drop Test
 - 6.6 Helix Torque
 - 6.6.1 Requirements
 - 6.6.2 Test Method
 - 6.7 Helix Bending
 - 6.8 Helix Tensile Load
7. ENVIRONMENTAL SPECIFICATIONS
 - 7.1 Temperature Shock
 - 7.2 Salt Spray
 - 7.3 Static Humidity
 - 7.4 Temperature Soak
8. RELIABILITY SPECIFICATIONS
 - 8.1 Connector Reliability
 - 8.2 Whip Bending Endurance
9. QUALIFICATION
10. PACKAGING
11. PRODUCTION SITE
12. QUALIFICATION FLOW CHART

**GALTRONICS CONFIDENTIAL AND PROPRIETARY INFORMATION - MAY NOT BE
COPIED OR DISCLOSED.**

**ANTENNA SPECIFICATION****1. PURPOSE AND SCOPE**

The purpose of this document is to establish a *design* specification for the antenna product that Galtronics is developing for Curitel, for their wireless handset. This specification is preliminary. Any changes or additions to this specification can affect schedule and/or cost of the product and should be negotiated between Galtronics and Curitel before being incorporated into the specification. Upon agreement of this specification Galtronics will make no changes without the written approval from Curitel. Any changes requested by Curitel will be given to Galtronics with sufficient time to evaluate the cost impact and react as required. The development of the product in Galtronics is conducted according to the Design Control Procedure SOP006E.

2. RELATED DOCUMENTS

SOP006E	Product Launch Procedure (Design Control)
EN006E	Reliability Guidelines
EIA-STD-556	Outer Shipping Container Bar Code Label Standard

3. ABBREVIATIONS AND DEFINITIONS

Ω	Ohm
°	Degree
°C	Celsius (degrees Centigrade)
cm	Centimeter
g	Grams
Hz	Hertz
MHz	Megahertz
m	Meter
mm	Millimeter
N	Newton
PCB	Printed Circuit Board
RH	Relative Humidity
W	Watt

Design specification: A preliminary target specification to guide design process

Product specification: A final specification for the qualified product

4. DESCRIPTION AND PART NUMBERS**4.1 DESCRIPTION**

This antenna is a base helical retractable for use on a wireless handset. This antenna shall consist of two electromechanical pieces: A whip and a base. The whip shall extend and retract through the center of a fixed base lower helical, which is mounted to the handset via a screw thread interface. The whip element shall function in the full up position and the base helical shall function in the down position.

The electrical, mechanical, and industrial design parameters required for this antenna are described below.

4.2 PART NUMBER

Galtronics Part Number	Frequency Bands
020678114-2372	CDMA / GPS / PCS

GALTRONICS CONFIDENTIAL AND PROPRIETARY INFORMATION - MAY NOT BE COPIED OR DISCLOSED.

ANTENNA SPECIFICATION**5. ELECTRICAL SPECIFICATION****5.1 FREQUENCY BANDS**

Band Name	Frequency Band
CDMA/AMPS	824 - 894 MHz
GPS	1575 MHz
PCS	1850-1990 MHz

5.2 IMPEDANCE

Nominal impedance (including matching circuit): 50Ω.

5.3 MATCHING REQUIREMENTS

In order to assure the best performance of the antenna, the matching will be evaluated in free space and in talk position for both extended and retracted position.

The antenna will comply with the Electrical Specification requirements, as set out below, while mounted on the handset containing the PCB. The handset with PCB are to be supplied by the customer and should be representative of the latest design version of all parts. Any modifications in the handset or PCB can affect the performance of the antenna and should be discussed with Galtronics to determine the affect of such changes on antenna performance and delivery requirements.

5.4 VSWR**Requirements in free space**

Band	Extended Position		Retracted Position	
	Tx1	Rx1	Tx1	Rx1
CDMA/AMPS	2.0:1	3.0:1	3.0:1	2.0:1
	Tx2	Rx2	Tx2	Rx2
PCS	4.0:1	4.5:1	3.0:1	3.0:1
GPS	4.0		2.0	

Transmit Band (Herein designated as **Tx1**) -the frequencies of operation for the Band transmit function shall be **824** to **849** MHz.

Receive Band (Herein designated as **Rx1**) -the frequencies of operation for the Band receive function shall be **869** to **894** MHz.

Transmit Band (Herein designated as **Tx2**) -the frequencies of operation for the Band transmit function shall be **1850** to **1910** MHz.

Receive Band (Herein designated as **Rx2**) -the frequencies of operation for the Band receive function shall be **1930** to **1990** MHz.

5.4.2 Test Method (Engineering)

The antenna is tested while mounted to the handset. The handset is set up with a 50Ω coaxial cable connected to the 50Ω point. Calibration is done at this 50Ω point. The other end of the 50Ω coaxial cable is connected to a network analyzer. The handset is positioned on a non-conductive table for free space measurements. VSWR is also evaluated in talk position on a phantom head for reference only.

5.4.3 Test Method (Production)

In mass production it is not practical to use the handset supplied by the customer. A production test fixture will be designed by Galtronics for use on processes requiring electrical testing. The results on the test fixture will be correlated to the customer handset. Testing in final inspection is done on a statistical basis.

**GALTRONICS CONFIDENTIAL AND PROPRIETARY INFORMATION - MAY NOT BE
COPIED OR DISCLOSED.**

**ANTENNA SPECIFICATION****5.5 GAIN****5.5.1 Gain Values (Free Space)**

CDMA/AMPS	The beam peak Gain in Azimuth plane	
Mode	Tx, dBi	Rx, dBi
Extended	2.0	1.0
Retracted	1.0	1.0
PCS	The beam peak Gain in Elevation cuts	
Mode	Tx, dBi	Rx, dBi
Extended	2.0	2.0
Retracted	1.5	2.0
GPS	The beam peak Gain in Elevation cuts	
Mode	Tx, dBi	Rx, dBi
Extended	1.5	
Retracted	1.0	

5.5.2 Test Method

The antenna is tested while mounted to the handset. The antenna is tested in free space in the anechoic chamber. Radiation patterns are measured at a minimum of 3 different frequencies.

5.6 POWER RATING**5.6.1 Requirements**

Maximum value: 1 W

5.6.2 Test Method

The antenna is connected to the handset housing as described in 5.4.2. A power of 1 W is applied to the antenna for a period of 30 min. for extended and retracted position at room temperature (+20°±3°C). The antenna shall satisfy electrical requirements in 5.4.1 after the test and have no visible deterioration.

6. MECHANICAL SPECIFICATIONS**6.1 MECHANICAL CONFIGURATION**

The appearance of the antenna is according to drawing 020678114-2372.

6.2 CONNECTOR TYPE

The connector type is M4.5X0.5 Threaded Mount Boss.

6.3 RETRACTION FORCES**6.3.1 Requirements for initial values**

Position	Force range (N)
F1	0.5-3.0
F2	0.5-5.0
F3	0.5-5.0
F4	0.5-3.0

(See Figure 1 below for definition of F designations)

GALTRONICS CONFIDENTIAL AND PROPRIETARY INFORMATION - MAY NOT BE COPIED OR DISCLOSED.

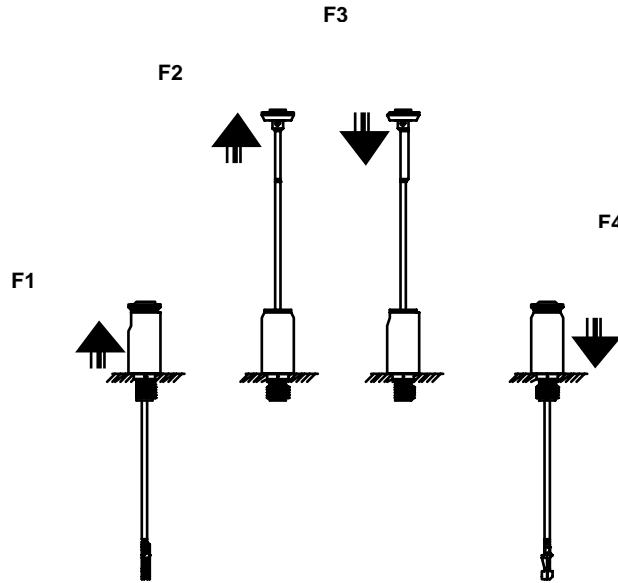

Figure 1. Force Designation for Retraction Forces

6.3.2 Test Method

The antenna is held fixed by the connector and gripped by the antenna cap. The antenna is moved from each position at a speed of 5 mm/s. The maximum force before the antenna is released is recorded. The mean force of 3 measurements for each position shall be within the specified values in 6.3.1.

6.4 PULL TEST

6.4.1 Requirement

50 N axial pull force for 30 seconds.

6.4.2 Test Method

With the antenna connector mounted in an appropriate test fixture, apply axial tension load 50 N along the longitude axis to the antenna cap during 30 seconds Whip element fully extended. The sample is subjected to visual checking as well as to checking of electrical and mechanical working characteristics and must not have suffered from irreversible mechanical and electrical damage.



Figure 2. Method for Pull Strength Measurement

GALTRONICS CONFIDENTIAL AND PROPRIETARY INFORMATION - MAY NOT BE COPIED OR DISCLOSED.

ANTENNA SPECIFICATION

6.5 DROP TEST

The antenna attached to a dummy weighted radio (100 grams) should withstand 2 drops directed towards the antenna onto a concrete surface. The drop height is 1.5m. The drops shall be executed in the retracted position. The antenna shall satisfy the electrical specifications in 5.4.1 after the test. The antenna should function mechanically after the test. The antenna can be physically straightened at the end of the test.

Temperature of the environment $+24^{\circ}\text{C} \pm 3^{\circ}\text{C}$.

6.6 HELIX TORQUE

6.6.1 Requirements

A torque of 30 Ncm to be applied to the helical. No appearance damage on antenna or mechanical deformation is admitted after the test.

6.6.2 Test Method

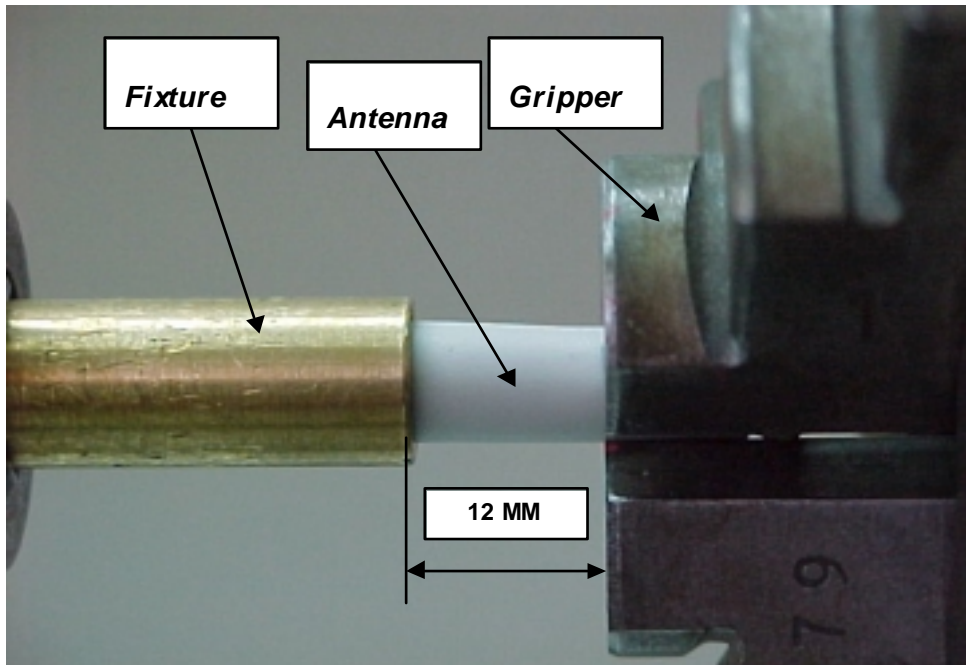

Figure 3. Method for Torque Measurement

The Torque Gauge element of the Measured device fits the simulator of the telephone fixture (Figure 3). The simulator is attached to the torque measuring device. Antenna with the fully inserted whip should be fitted to the fixture that simulates dimensions of the antenna set in the radio case. The gripper clamps the antenna base helical at distance of 12 mm from the simulator of the telephone fixture. The initial fit moment should be $10.0 \text{ Ncm} \pm 1 \text{ Ncm}$. Then the handle of the gripper should be rotated in the CW direction until the additional moment of 20.0 Ncm is generated.

No loosening of joints between details of the antenna should be revealed after the test. The antenna shall satisfy the electrical specifications in 5.4.1 after the test.

ANTENNA SPECIFICATION

6.7 HELIX BENDING

With the antenna connector mounted in an appropriate test fixture, apply lateral load 40 N to the helix with bend of helix no more than 30°. Whip element inserted. The sample is subjected to visual checking as well as to checking of electrical and mechanical working characteristics and must not have suffered from irreversible mechanical and electrical damage.

6.8 HELIX TENSILE LOAD

With the antenna connector mounted in an appropriate test fixture, apply axial tension load 50 N along the longitude axis to the helix. Whip element inserted. The sample is subjected to visual checking as well as to checking of electrical and mechanical working characteristics and must not have suffered from irreversible mechanical and electrical damage.

7. ENVIRONMENTAL SPECIFICATIONS**7.1 TEMPERATURE SHOCK**

Place complete antenna in an environmental chamber at temperature T1= -40°C. Expose antenna to this temperature during 60 minutes. Then increase temperature to value of T2= +85°C during 30 minutes and soak at this temperature during 60 minutes. Relative Humidity must be 50% RH. Repeat this cycle 24 times. After test is complete: soak samples for 4 hours at room temperature. There shall be no visual deterioration or damage. Electrical characteristics should be within the specified range.

7.2 SALT SPRAY

Place complete antenna in Salt Spray Cabinet at temperature +35°C with the salt fog of NaCl solution (5%); soak time - 48 hours. After test is complete: soak samples for 4 hours at room temperature. There shall be no visual degradation in esthetical and mechanical performance. Electrical characteristics should be within the specified range.

7.3 STATIC HUMIDITY

Place complete antenna in an environmental chamber at +20°C. Increase temperature with speed 1° per minute to +70° C with humidity increasing to 95% RH during 2 hours. Soak antenna with these parameters for 48 hours. After the finish initial ambient parameters should be achieved during 1 hour. After test is complete: soak samples for 4 hours at room temperature. There shall be no visual degradation in esthetical and mechanical performance. Electrical characteristics should be within the specified range.

7.4 TEMPERATURE SOAK

The antenna to be subjected to the high temperature soak at +85°C for 48 hours and to low temperature soak at -40°C for 48 hours. After test is complete: soak samples for 4 hours at room temperature. There shall be no visual degradation. Electrical characteristics should be within the specified range.

**GALTRONICS CONFIDENTIAL AND PROPRIETARY INFORMATION - MAY NOT BE
COPIED OR DISCLOSED.**

ANTENNA SPECIFICATION

8. RELIABILITY SPECIFICATIONS

8.1 CONNECTOR RELIABILITY

The antenna shall withstand 20,000 retraction cycles. The antenna should be rotated periodically during the test. After testing the retraction forces should not be less than 50 grams.

8.2 WHIP BENDING ENDURANCE

With the antenna mounted in an appropriate test fixture, cycle the whip left/right 90° to the vertical 1000 times at a rate of 20-30 cycles/min.

Conditions: At +25° C, Whip element extended.

The sample is subjected to visual checking as well as to checking of electrical and mechanical working characteristics and must not have suffered from irreversible mechanical and electrical damage.

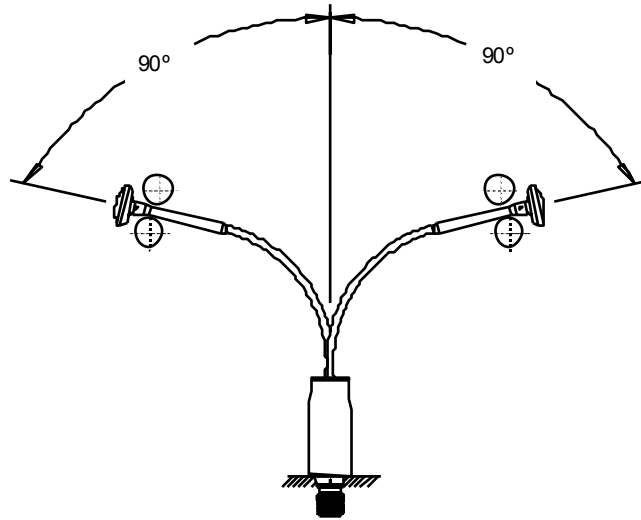

Figure 4. Method for Whip Bending Endurance Testing

9. QUALIFICATION

The mechanical, environmental and reliability tests mentioned above are performed according to the flow chart shown in Figure 5 below. The entire testing procedure will be conducted according to EN006E. A summary report of the results of the tests will be sent to the customer. Galtronics will not start mass production until the customer will grant the product a qualified status.

ANTENNA SPECIFICATION

10. PACKAGING

The antennas will be packed in compartmentalized vacuum-formed trays. There are 40 antennas per tray. (See Appendix) The trays are packed in a corrugated fiberboard over box, 32 trays per box. The over box will be labeled for shipping according to the standards outlined in EIA-STD-556 (See Figure 7).

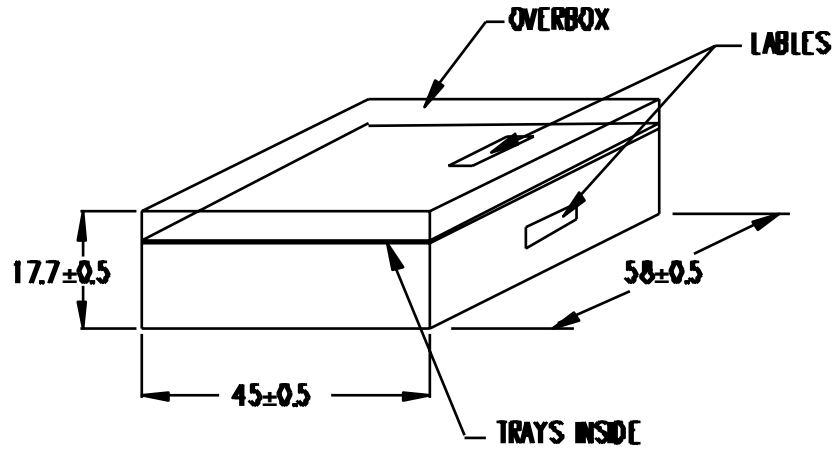

Figure 7. Packaging (dimensions of overbox in cm)

The labels should provide following information:

- Supplier's Address;
- Customer's Address;
- Package Count;
- Package Weight;
- Ship Date;
- Ship Number;
- Sales Order Number;
- Vendor's Part Number;
- Package Identification (Bar Code);
- Special (Bar Code);
- Total Quantity (Bar Code);
- Transaction Identification (Bar Code);
- Customer Product Identification (Bar Code).

11. PRODUCTION SITE

Galtronics Israel will manufacture the antennas.

Address: P.O.Box 1589, Tiberias, Israel

Tel: 972-4-6739777

Fax: 972-4-6732037

ANTENNA SPECIFICATION

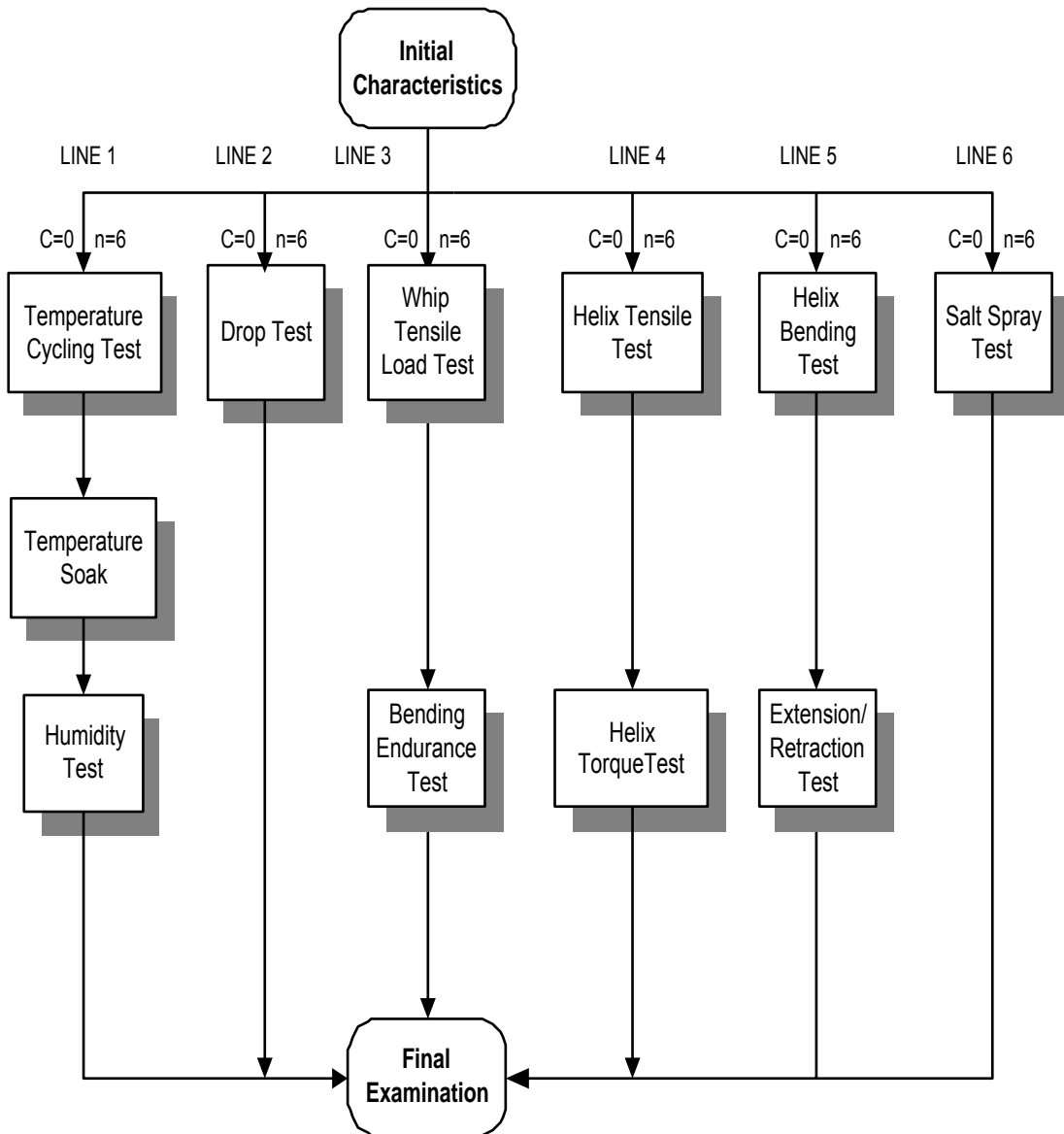

Figure 5. Qualification Flow Chart

Allowed amount of failures after every test line c=0; Sample size n=6

GALTRONICS CONFIDENTIAL AND PROPRIETARY INFORMATION - MAY NOT BE COPIED OR DISCLOSED.